

76

A New Sorting Facility for Federal Express: Strategically Integrating the Social and Technical Systems

by
Randall Alan Johnson
Bachelor of Science in Architecture
The University of Texas at Arlington
Arlington, Texas
May 1993

Submitted to the Department of Architecture in partial fulfillment of the requirements for the degree of Master of Architecture at the Massachusetts Institute of Technology

February 1998

The author hereby grants to MIT permission to reproduce and distribute publicly paper and electronic copies of this thesis document in whole or in part.

© 1998 Randall Alan Johnson. All Rights Reserved.

authored by:
Randall A. Johnson
Department of Architecture
January 16, 1998

certified by:
Andrew Scott
Associate Professor of Architecture
Thesis Co-Advisor

certified by:
William Porter
Professor of Architecture
Thesis Co-Advisor

accepted by:
Roy Strickland
Associate Professor of Architecture
Receiving for the Department

MAR 27 1998

LIBRARIES

Thesis Abstract

A New Sorting Facility for Federal Express: Strategically Integrating the Social and Technical Systems

by

Randall A. Johnson

Bachelor of Science in Architecture
The University of Texas at Arlington
Arlington, Texas
May 1993

Submitted to the Department of Architecture in partial fulfillment of
the requirements for the degree of Master of Architecture at the Massachusetts
Institute of Technology

February 1998

William Porter

Professor of Architecture
Thesis Co-Supervisor

Andrew Scott

Associate Professor of Architecture
Thesis Co-Supervisor

Woodie C. Flowers

Pappalardo Professor of Mechanical Engineering
Thesis Reader

This thesis examines the role of the industrial facility as a workplace and its contribution to the built environment. The usual solution of the “big box” is unfortunate, for it typically creates dreadful working conditions absent of natural light and natural ventilation. Its overall form is without any expression of the processes contained within or around its boundaries. The thesis also questions the role of architecture and its inability to effectively offer alternative solutions.

Yes, these types of corporate projects are generally very predetermined, with so many guidelines that little or no architectural invention is possible – so they say. But here is where architects and design are needed most, not the museum projects where “anything goes” – what’s the challenge? Federal Express has plans to build 50 of these facilities over the next three years and will probably stamp out box after box ... because it’s easier and cheaper.

So I’m jumping into the game head first. A flat site with no trees. A corporate client with a solution already in hand. A program about distributing cardboard boxes through a maze of machinery. Is there architecture in that?

DEDICATIONS

To my wife Debbie ...

I will never be able to say thank you enough for all of your constant understanding and commitment. This has been a difficult journey for both of us ... I look so forward to our new beginning.

To my parents ...

Thank you for all of your support. Debbie and I could have never done this without your help.

To my In-laws ...

Thank you for always having Debbie, Redding, and me in your prayers. It has been a tremendous gift.

THESIS POSITION

My position on the requirement of a thesis is that it creates an opportunity for one to begin to synthesize the various areas of thought that one has pursued, in this case over the last two and a half years, into both questions and answers that may contribute to a larger intellectual body of work. At least that's what many of us hope to do. It can be a difficult and daunting task though, particularly through an architectural thesis, because many times the emphasis is on *process*, not the project itself. When approaching the thesis as just another academic exercise in a long series of exercises, perhaps that emphasis has some advantages. But this, for many students, is the *final* academic exercise and should ultimately be about the *project* – the what, not the how. I'm not suggesting the *process* isn't important during the thesis – it is – I just think that after six and a half years, it is high time that we expect very intelligent *conclusions* from the student body, not just more sketches that do nothing more than *search for form* (gag) ...

TABLE OF CONTENTS

Introduction	p 10
Thesis Platform	p 16
Why Federal Express?	p 18
Location: Alliance Airport	p 26
Developing the Program	p 36
Design Platform	p 44
Analysis of Alternative Design Schemes	p 46
The Design Solution	p 80
The Social System	p 86
The Technical System	p 114
Conclusion	p 134
Sketches	p 136
Image Credits	p 170
Bibliography	p 172

INTRODUCTION



In the late 1980s, the pressure for restructuring for more effective performance was strongest on the middle levels of the organization. This trend has continued throughout the 1990s. Computers and information technology have made the information needed to monitor and control activities available simultaneously to upper management, to supervisors, and to individual workers. The information gathering and control functions that have been the staple of middle management have become less necessary. At the same time, demands from employees at lower levels of the organization to have a say in decisions that affect them have been met with a desire from upper management to decentralize some of their responsibility and to delegate some of their decision downward. The combined result has been the widespread collapse of vertical boundaries in the middle levels of organizations.

Also, individual, work-group and higher-level organizational issues have not been treated as part of the *factory of the future*, in which there will undoubtedly be fewer employees. These remaining individuals, by virtue of their new responsibilities and for business expenses and critical resources, will have considerable influence over the various types production process. Employees now must be highly motivated and work together as effectively as possible. Therefore, some important questions must be asked. Are some spatial arrangements better than others for organizing and do these arrangements differ for different kinds of facilities? As organizational boundaries collapse, both vertically and horizontally, how is the operator and technology being integrated? How do businesses come to understand the alternatives they have in linking social and technical subsystems, particularly when technology is flexible and social system alternatives exist?

Organizational theory informs organizational design and sometimes the concepts that underlie one or the other are difficult to untangle. Various lists of characteristics, attributes, principles, and work-force strategies have been developed, many of which are redundant, but all of which contribute to a better understanding of *sociotechnical systems* (STS) and assist in transforming the theory into practice. A sociotechnical systems approach to the design of organizations is based on three broad themes:

- **the organization is an open system in continuous interaction with its environment**
- **the design of organizations is based on the joint optimization of the social and technical systems**
- **there are choices in the organizational design**

Interestingly, the concept of an organization as an open system has been adopted from biology in order to recognize that organizations are complete undertakings with inputs, outputs, throughputs, and feedback mechanisms to monitor and adapt their performance. Unlike biological entities though, organizations are capable of changing their state in a relatively short amount of time, in large part due to an external environment that exposes them to a high degree of uncertainty and fluctuation. They are collections of individuals formed into units that can be viewed as *mini-societies* with highly differentiated roles, structures, rewards, and processes for interacting, developing and sustaining themselves. They are learning entities, sometimes learning to maintain the status quo, sometimes learning to change it continuously in the light of changing contexts, values and objectives.

Another basis of a sociotechnical systems approach is *joint optimization*. This theory considers the social and technical systems much more as equals in the design process. It has always been accepted that the first step in the design of a production process is to lay out the logical flow of the technology to achieve the desired final product, an input-throughput-output sequence. Workers in the process are then added in as needed, usually when it is less expensive to add a worker than to add an additional technological component, i.e. installing an operator to monitor a machine because automatic monitoring is too expensive or technically not feasible. At this point, the technical system is optimized for efficiency, for the cost of the investment in technology, for the quality of the output, etc. The workers and the social systems are seen as extensions of the technical system, as necessary appendages to make the system function properly.

Under joint optimization, there is an understanding that there may be trade-offs, whereby giving up some efficiencies on the technical side to realize social system benefits may yield a better outcome. For example, physically arranging a manufacturing cell in a U-shaped sequence rather than placing the machines in a straight line may make it more technically difficult for some tasks. However, the physical proximity of various types of operators to each other should allow them to cover for each other during absences, advise each other, learn from each other, and generally improve their social system as well as the overall effectiveness of the cell. Joint optimization may be an optimistic objective, since optimizing any system or subsystem, technical or social, is difficult. However, achieving a match between the technical and social subsystems is a feasible objective and can result in a more effective organization than one that develops only the technical or the social subsystem.

Joint optimization has now acquired new significance under computer-based technology. With the programmability and the flexibility that is now being approached in the technology, it is conceivable that facility design can begin to integrate and affect a desired social system outcome, i.e. an organization structured around teams, without incurring extra cost for the technology or without sacrificing technical objectives. The number of alternative organizational arrangements is expanding. Now, the challenge for designers is how to optimize these two subsystems so that both have flexibility within the range of given alternatives.

This thesis is an architectural exploration of joint optimization theory, combining the pragmatic functions and systems that a business must have to be productive and efficient, as well focusing on the resulting social implications that develop from the implementation of these pragmatic systems. The mitigating force of architecture will be offered as a potential element that, when combined with management theory, can contribute to the design of a profitable system.

THESIS PLATFORM

An **industrial building for a corporate client** does not have to be a “big box”.

An **industrial building for a corporate client** can perform as a successful workplace.

An **industrial building for a corporate client** must contribute to the built environment.

An **industrial building for a corporate client** is more of a design challenge than a museum.

WHY FEDERAL EXPRESS ?



To never have heard of Federal Express (FedEx) would require one to be under a very large rock for a very long time. It is the largest express transportation company in the world and has an enormous presence in our present-day, fast-paced economy. Established in 1973 by Frederick W. Smith, the President and CEO, it employs approximately 128,600 employees and had 1996 revenues of \$10.3 billion.

Interestingly, Fred Smith's original idea for FedEx was formed while an undergraduate at Yale University. He included the idea in a thesis paper that described his vision of overnight delivery and how the global economy would value such a service. Mr. Smith received a grade of "C" on that paper. I suppose he has had the last laugh.

When I began deciding which company I would fold into this thesis, FedEx became the clear choice rather quickly. I wanted a large, visible corporation that was a leader in their respective market and was currently in a facility building phase. Also, they had to be actively seeking new alternative solutions for the various aspects of their business, i.e. consumer satisfaction, revenues, expenses, etc. FedEx is continuously updating and searching for new technologies, whether it be their freely-distributed computer software, proprietary computer hardware, web site design, or their own television station - FXTV. They want to be the best in their business. So I believe that behind this constant search for improvement, is a company that would be very able to see the advantages in developing and creating a truly unique facility experience for its employees. This, to me, was essential because it brought together the designer and an engaging, willing participant in the design process – a potentially successful combination.

The company also had to have an active interest in employee satisfaction. Because the thesis was a design with people in mind, not just machines, I wanted to involve a company that saw their employees as the number one asset that they have. This was evident the more and more I researched FedEx.

Here is the list of their *Hub Operations Strategies*:

- Establish a dynamic organizational structure that is progressive and responsive to the business needs in a changing environment.
- Provide appropriate programs for the training and development of our people that improve the results, effectiveness, and creativity of the person and the organization.
- Provide a comprehensive management information system that is user-friendly and real-time.
- Create an atmosphere and network that promote effective communication of information and issues.
- Require the total commitment of staff and line to the planning process, producing a superior system that maximizes assets and exceeds customer expectations.
- Foster an environment that ensures a security and safety conscious work force.
- Promote an atmosphere that ensures a mind-set in which quality and productivity are synonymous with “doing it right the first time.”

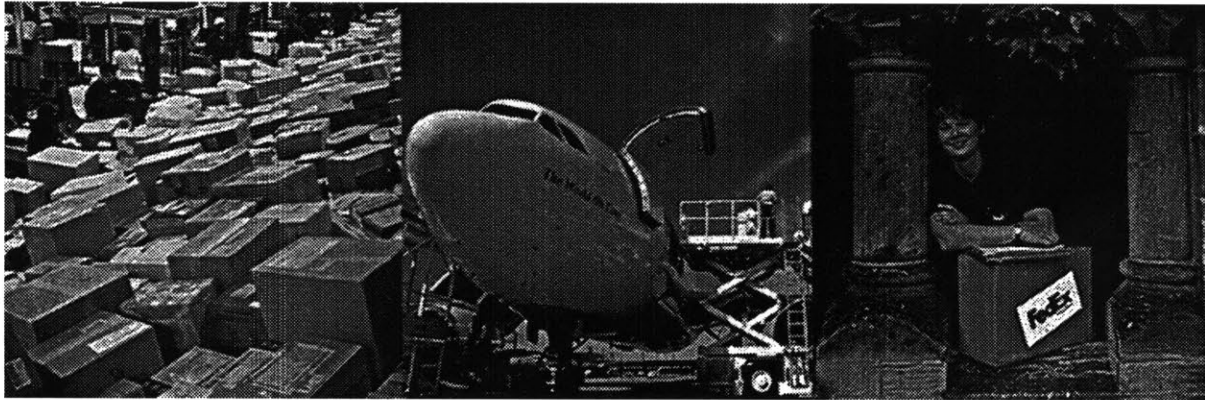
This is a corporation that I feel would be willing to consider alternative facility designs if only they had some alternatives from which to choose. These kinds of projects – the Wal-Marts and such – are frequently left to those architecture firms that simply churn out the same bad solution over and over through the use of their favorite CAD software.

It’s too bad that the academic community doesn’t see this situation as an opportunity to contribute to its own profession - a profession that doesn’t need constant exploration of the latest style from its students, but something more tangible and real.

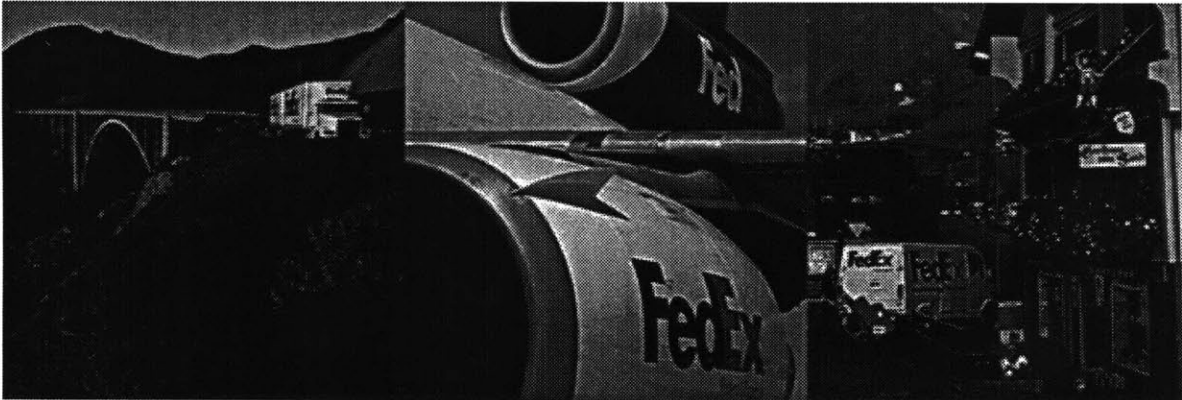
Repeatedly in architecture schools and other liberal disciplines, there is a complete dismissal of “Corporate America” – for all kinds of reasons. It is seen as the bully and the bad guy, and together with capitalism has and forever will be labeled as the reason we have residential subdivisions with only three different house styles, the reason there is the same retail chain store every 3 miles, and the reason we are a *commodity culture*.*

*see Thresholds 15 ... as if artists and architects weren’t some of the biggest consumers of *what’s hip* !

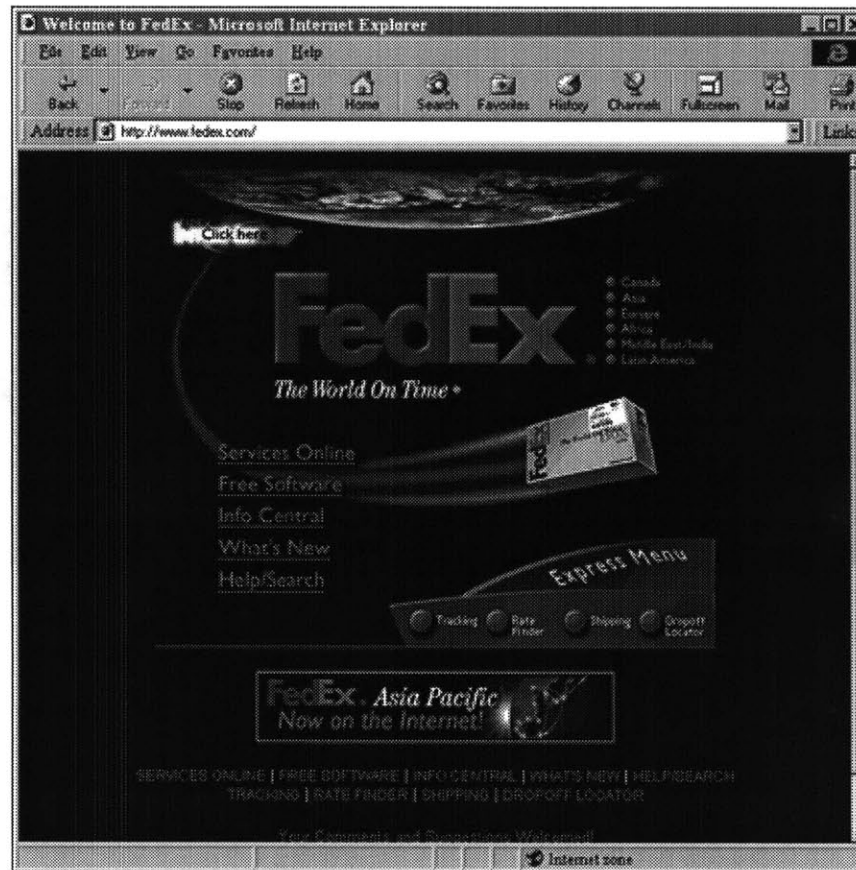
FEDERAL EXPRESS IS A



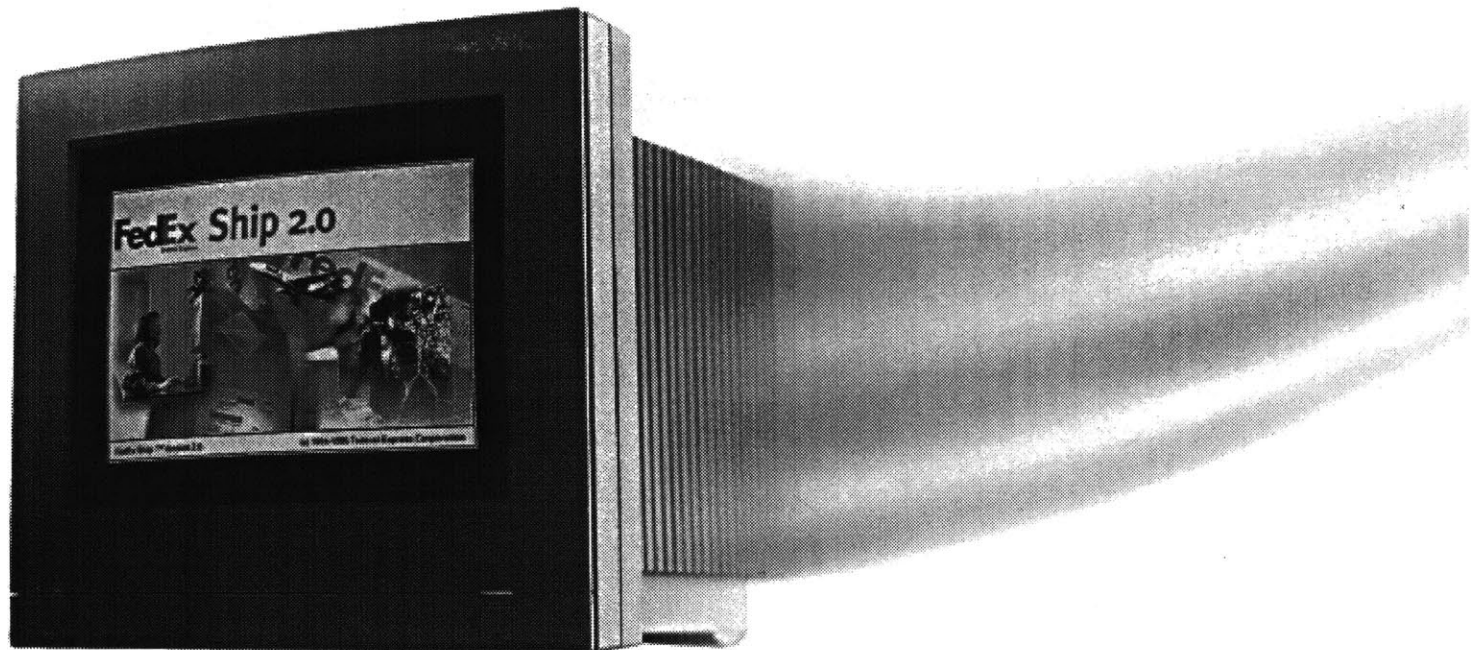
VERY VISIBLE COMPANY



FEDERAL EXPRESS IS A



VERY PROGRESSIVE COMPANY



**LOCATION :
ALLIANCE AIRPORT**



“In the late 1980s, the FAA approached the owners of the land that is now Alliance with the idea of locating an airport in the region ...

... the developers envisioned more than an airport – they envisioned an entirely new type of airport and a unique business community.”





Alliance Airport, an international industrial center and intermodal transportation hub, is in north Tarrant and south Denton counties. About 15 miles north of downtown Fort Worth and 15 miles west of Dallas/Fort Worth Airport, the center has been designated a foreign trade zone with freeport exemption status via the recent North American Free Trade Agreement (NAFTA) with Canada and Mexico. The commercial emphasis of this airport has been so well received that it has attracted almost 40 top companies such as American Airlines, Intel, Mitsubishi, Federal Express, UPS, and others to the immediate surrounding area. These companies have not only relocated an office, but have poured an enormous amount of financial resources into their own general support and/or manufacturing facility.

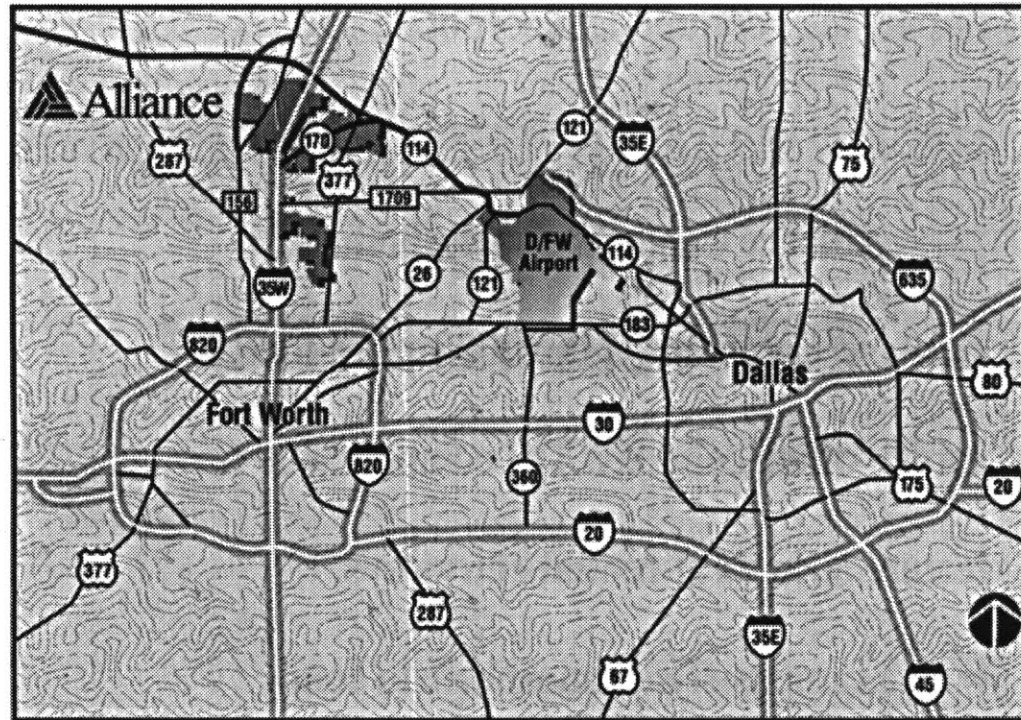
Alliance Development Company, a subsidiary of Hillwood Development Corporation, is owned by Ross Perot, Jr. and is committed to careful, planned growth. From day one, they have consulted leaders in fields of architecture, engineering, and planning in order to transform the surrounding context into a world-class business and residential community. The goal is to ensure the highest quality of development and the ideal environment to lead emerging markets and opportunities.

Alliance Development Company has also recently asked for development proposals from the nation's top academicians and students in order to establish ideas that will form the foundation for an upcoming master plan of the former 2,000 acre Circle T Ranch. This new development will integrate commercial and residential projects, featuring corporate headquarters facilities, campus-style office complexes, upscale retail centers, recreational facilities, and executive-style estate and homes.

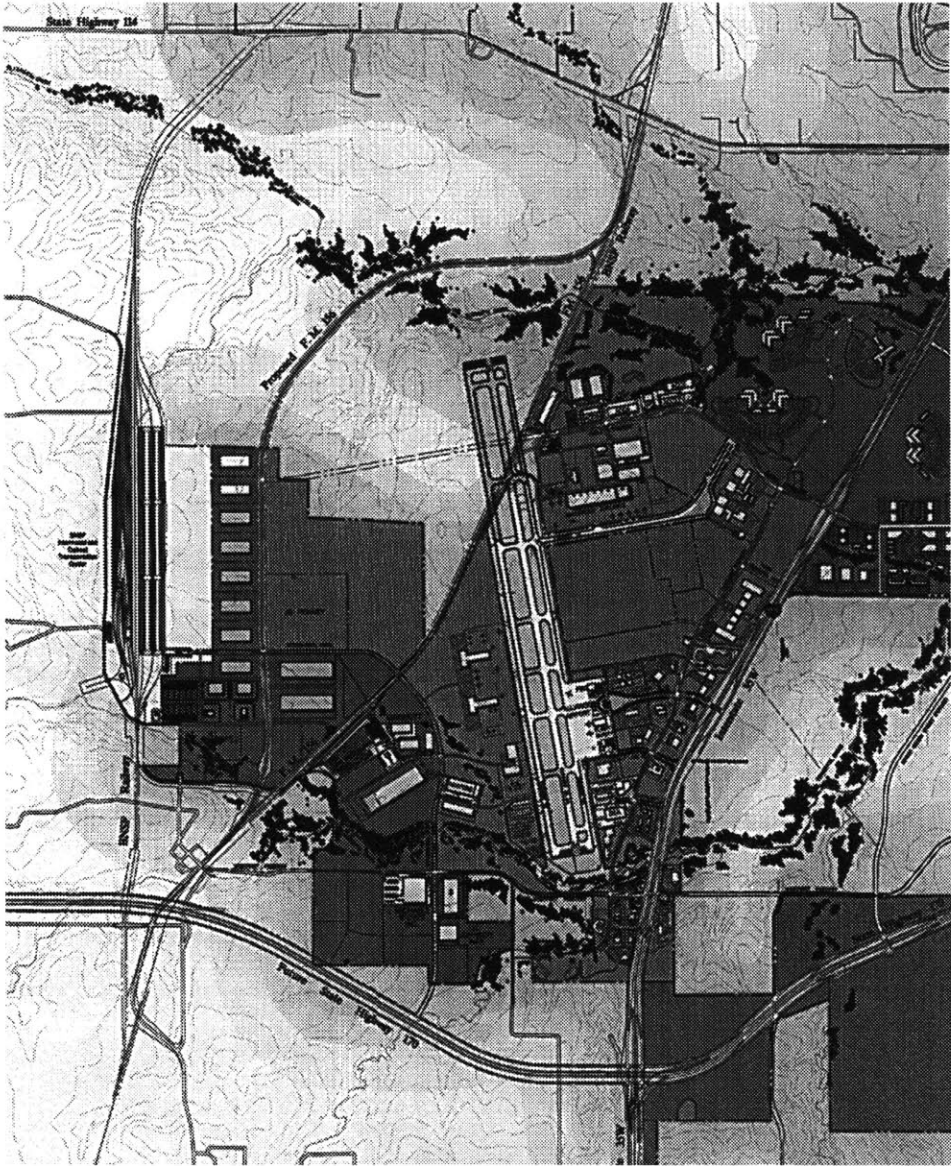
Development companies generally receive a bad name within architecture schools, many of them for good reason. Often times they seem to be the sole reason for urban sprawl and numerous other unfortunate conditions. But architects have been responsible for poor planning and design, too. The blame cannot simply be passed on ...

I would argue that developers like those with Alliance Development Company are the kind of developers with whom architects should team. They are looking for good design, they want better design solutions, and they want something different than the status quo. These are rare opportunities. Let's seize them when they appear...

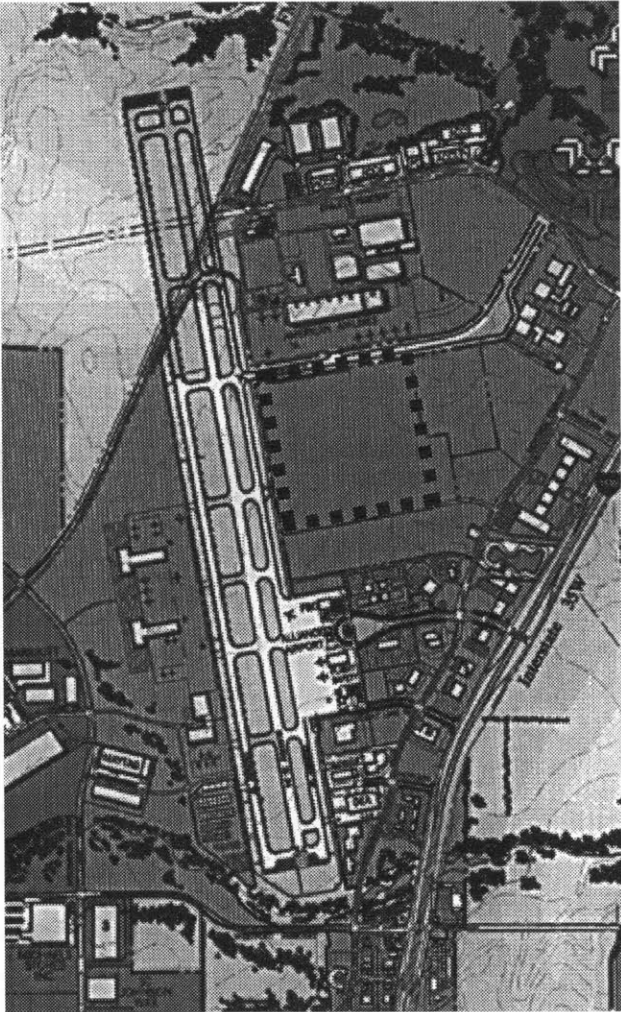
VICINITY MAP



SURROUNDING CONTEXT



PROPERTY LINES



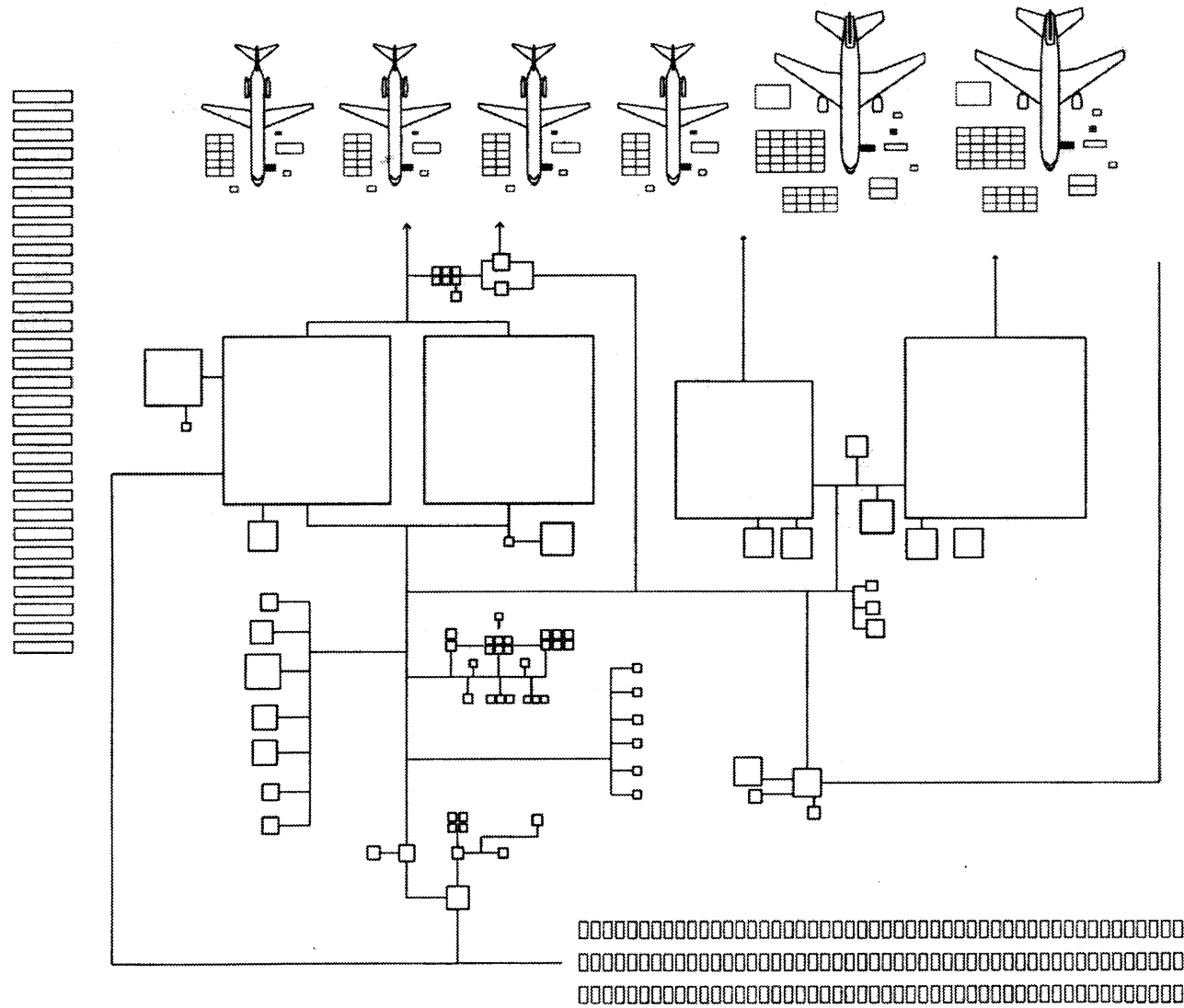
DEVELOPING THE PROGRAM

The program for this thesis was difficult to assemble and took considerably more time than I had hoped. But it was essential that the relationships among the various parts of the program be very clear in order for me to objectively analyze the various programming options. I spent approximately one month putting the basic program together and then fine tuned it with two sorting facility visits. Ben Harris, Head of Architectural Programming for FedEx, was kind enough to fly to Boston to give me a tour of Boston's Logan Airport Facility and the Franklin, Massachusetts Facility. These tours were invaluable because they made the internal and external sorting process literally very visible. The time spent up to that point was just seeing the process on paper and speculating what the actual processes might be. Mr. Harris was also helpful in pointing out the things that FedEx liked and didn't like about their facilities, some of the problems that they have in building them, and what the future held for the FedEx sorting facility as they currently knew it. This information allowed me to be a bit more provocative with my own design proposals.

The program consists of the following functional units and percentages:

- | | |
|----------------------------------|------------------|
| ▪ Customer Service | 20% - 30% |
| ▪ Office Operations | |
| ▪ Warehouse Operations | |
| ▪ Truck Dock Operations | |
| ▪ Aircraft Ramp Operations | 70% - 80% |
| ▪ Aircraft / Vehicle Maintenance | |

ORGANIZATIONAL CHART



PROGRAM REQUIREMENTS

Customer Service Operations

Customer Reception Lobby	140 sf min.
Customer Service Agents Office	4 @ 100 sf
Customer Service Desk	100 sf
Expedite Office	120 sf
Hold at Location (HAL) Room	100 sf min.
Vestibule Area/Lobby	600 sf

Conventionally, this is the only portion of the program that has any aspect of design and, unfortunately, the extent at any attempt of an overall corporate image.

Office Operations

Account Mgr. Office	2 @ 100 sf each
Account Sr. Mgr. Office	150 sf
Administrative Assistant Office	6 @ 80 sf each
Break Room	15 sf/user ; 1 @ 1500 sf, 1 @ 625 sf
Building MX Office	80 sf
Check-in Office	90 sf
Computer Equip. Room	170 sf
Conference Room	6-8 sf/user - 340 sf
Copy Room	80 sf
Electrical Room	80 sf
Engineer Office	3 @ 80 sf each
File Room	150 sf
Janitor	50 sf
Lobby	380 sf
Mechanical Room	350 sf
Men's Locker Room	5 sf/user - 430 sf
Men's Restroom	per code : 1 @ 432 sf, 1 @ 110 sf
Operations Manager Office	1 mgr. / 15 employees - 6 @ 100 sf each
Public Restroom	35 sf
Radio Equipment Room	80 sf
Sales	3 @ 70 sf each
Security	100 sf
Sr. Manager Office	1 Sr. Mgr./12 managers - 2 @ 120 sf each
Telephone Equipment Room	100 sf
Training Manager	120 sf
Training Room	20-25 sf/user - 1 @ 600 sf
Women's Locker Room	5 sf/user - 1 @ 350 sf
Women's Restroom	per code - 1 @ 350 sf, 1 @ 110 sf

Much of this part of the program was labeled as 'common functions' and soon became an anchoring piece in the eventual design scheme (see page 81 & 83).

However, certain aspects of the office operations were naturally made part of each module, such as the office managers and some support staff positions.

Warehouse Operations

Computer Room	190 sf
Customs Agent Office	80 sf
Dispatch/Controller	100 sf
Electrical Room	200 sf
Employee Check-In	300 sf
Equipment Room	200 sf
Flight Crew Office	340 sf
Heavyweight Warehouse Area	varies
In-Bond Storage	4000 sf
JIT Storage	XXX sf
Jumpseat Waiting Room	190 sf
Ramp Agent Office	75 sf/user - 1 @ 450 sf
Sort Maintenance Office	100 sf
Sort Maintenance Shop	865 sf
Warehouse – Express Sort	varies

As the largest part of the overall program, as well as housing the main function of the facility, the warehouse layout drives the design scheme. Therefore, much of the innovation and exploration of the thesis was applied here. Also, JIT Storage was added to the program during the thesis due to the fact that FedEx made public their intentions to offer this service to their customers in the near future.

Aircraft Line Maintenance

Aircraft Line MX Office (727/DC-10 Fly Thru)	50 sf/user – 1 @ 150 sf
Aircraft Line MX Office (727 Layover)	50 sf/user – 1 @ 200 sf
Aircraft Line MX Office (DC-10 Layover)	50 sf/user – 1 @ 350 sf
Aircraft Line MX Parts	2 @ 1000 sf
Aircraft Line MX Shop	3 @ 1125 sf
Aircraft Technical Stores (Thru Station)	500 sf
Aircraft Technical Stores (Layover)	1300 sf

This is usually contained in one separate building in some proximity to the larger facility. My intentions were to incorporate these functions back into the overall facility in some way.

GSE and Vehicle Maintenance

GSE/Vehicle MX Office	50 sf/user
GSE/Vehicle MX Parts	1000 sf minimum
GSE/Vehicle MX Shop	1000 sf minimum
GSE/Vehicle MX Tools Storage	200 sf
Men's Restroom	35 sf
Women's Restroom	35 sf
Breakroom	170 sf

This, too, is typically set off from the rest of the main facility. Without compromising its autonomy, I wanted to place it closer to the everyday functions of the main facility.

Loading Dock

CTV truck parking	33 @ 12.5 x 66 each
Customer parking	1 @ 12.5 x 20

Aircraft Gate Information

DC-10	182 L x 155 W : gate = 40,500 sf
fire extinguishers	4 @ 3 x 3
belt loader	7 x 25
dolly	26 @ 9 x 15
LD3 dolly	13 @ 9 x 15
crew stair	7 x 15
LD loader	2 @ 11 x 30
UD loader	23 x 38
GPU	9 x 6
Light Unit	2 @ 8 x 6

The requirements surrounding the DC-10 were expanded to accommodate future aircraft purchases of MD-11s. The MD-11 is approximately 25' longer and 10' wider than the DC-10.

727-200	153 L x 108 W : gate = 23,500 sf
fire extinguishers	2 @ 3 x 3
dolly	11 @ 9 x 15
crew stair	6 x 11
LD loader	11 x 30
GPU	9 x 6
Light Unit	8 x 6

The 727 is a popular, inexpensive aircraft widely used in the FedEx global sorting process. It's capacity is much smaller than the DC-10, but it makes sense on shorter routes.

Site Requirements

Aircraft Apron	(6) 727s and (6) DC-10s / MD-11s
CTV Parking	83 spaces @ 12 x 65
Customer/Visitor Parking	6 spaces @ 10 x 18
Employee Parking	157 spaces @ 10 x 18
Handicapped Parking	3 spaces @ 13 x 18
Vehicle Que Gate	2

FedEx currently has no real 'gate' system; aircraft are positioned together on a large aircraft ramp where trucks drive to and from the loading / unloading process

DESIGN PLATFORM

- Facility must address issues of **expansion**
- Organizational structure should be less departmental and more **team-oriented**
- Programming solutions should explore **innovative** and **alternative** methods of combining people and machines
- Design should combine the social and technical aspects of the program into an **expressive corporate image**
- Parti must offer **high visibility** and **access** to and from the sort system, trucks, and planes
- Workforce must have access to **natural light** and **ventilation**
- Building should incorporate a **low-cost** approach to energy use

ANALYSIS OF ALTERNATIVE DESIGN SCHEMES

After the program was fully assembled, I began to investigate the range of alternative layouts that the program might afford. The schemes were developed mostly without regard to the strict program requirements, mainly to avoid any conventional solutions. This was a phase in the thesis where any solution was seen as viable, at least initially, then would be analyzed and judged later as part of a larger collection.

The schemes were developed through numerous sketches, then diagrammed and recorded in AutoCAD. This database of information was linked to other AutoCAD drawings, namely the organizational chart and the programmatic diagram in order to check the *tolerance* of spatial relationships. As this part of the thesis was primarily interested in exploring the potential successes of architectural programming, this method of analysis was essential to develop realistic alternative schemes based on the Federal Express requirements, as well as ones that would eventually become part of my own presentation.

I chose fifteen schemes as representative of my thinking and overall approach to the solution of this program. The schemes were then placed collectively in a chart and given a score of 1 to 5 (5 being the best) on the basis of the ten following, equally weighted criteria:

- **Is the overall system expandable?**
- **How well can management oversee the personnel?**
- **How well do the truck docks relate to the sorting system?**
- **How well do the airplane gates relate to the sorting system?**
- **How well do the common functions (break room, large conference room, cafeteria, etc.) relate to the warehouse area?**
- **Does management have good visual and physical access to and from the trucks and planes?**
- **Does management have good visual and physical access to and from the sorting system?**
- **Does the scheme maximize the potential quantity of truck docks?**
- **Does the scheme maximize the potential quantity of airplane gates?**
- **Is the scheme reflective of a departmental or team-based organization?**

The results of the analysis of the fifteen schemes are shown in following table:

Scheme	Expandability of system	Mgmt to personnel	Trucks to sort system	Planes to sort system	Common functions to warehouse	Mgmt to trucks/planes	Mgmt to sort system	Quantity of docks	Quantity of gates	Departmental or team-based	Total Score
1	1	2	2	1	3	2	2	5	5	2	16
2	2	2	2	3	2	3	3	4	4	2	27
3	1	3	3	3	3	3	3	4	3	2	28
4	3	2	4	4	3	2	2	3	3	3	29
5	2	3	2	2	4	3	3	3	4	3	29
6	2	4	3	2	5	3	4	5	4	2	34
7	5	2	3	3	3	3	3	5	5	3	35
8	3	3	4	4	3	3	3	5	5	3	36
9	3	4	5	5	4	3	3	5	3	4	39
10	4	3	5	5	4	3	3	5	3	4	39
11	4	3	5	4	4	3	3	5	3	4	40
12	2	5	4	4	5	4	4	5	4	5	42
13	5	4	5	5	3	4	4	5	4	5	44
14	5	4	5	4	4	4	4	5	4	5	44
15	5	4	5	5	4	5	5	5	4	5	47

Scheme **1** incorporates an office tower between a curved airline gate system and a straight truck dock system. The sort system, as well as much of the personnel activities, would be in the open area between the aircraft and the trucks. The entry into the facility would be just to the left of the truck docks under a roof overhang.

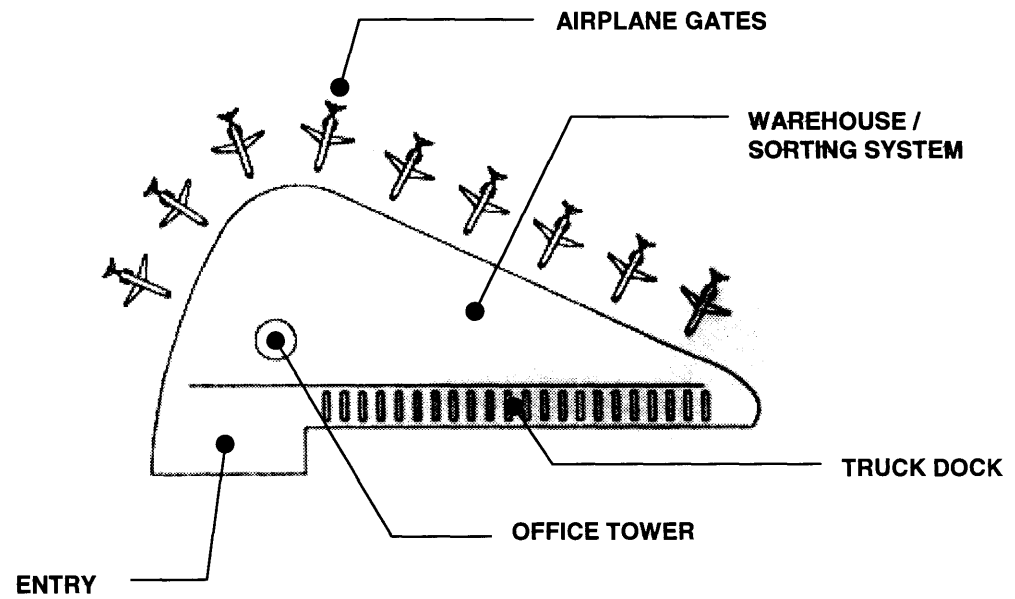
The office tower would provide good views of most of the facility and would serve as a focal point for the interior and exterior of the facility. The tower would contain all the administrative functions, as well as the common functions. The common functions would be situated in the upper portions of the tower where the tower would extend beyond the roof, allowing the employees to figuratively 'leave' the facility during breaks and other down time.

The sorting system in this scheme would be compromised by the varying distances between truck and plane. The relationship of truck to plane can be good or bad, depending on which gate and dock you are analyzing. The 'shapes' of the spaces from office tower to airplane gate, as well as airplane gate to truck dock, which would potentially contain like-functions, would be pie-shaped and of varying acute and obtuse angles. These would be unacceptable conditions.

The overall shape of the facility also creates a closed system. The only option for expansion would be to mirror the entire facility about the axis running along the truck dock.

Scheme 1

16 / 50



Scheme **2** separated the major parts of the program (customer service and office, warehouse, truck sort, airplane sort) into their respective districts, linking them by a large open corridor system. The spaces along the corridor would be the common functions, such as break rooms, restrooms, conference rooms, and training rooms. This arrangement of common spaces would create an interior 'main street' and would serve as the place where planned and accidental meetings could happen and where ideas could be shared over coffee.

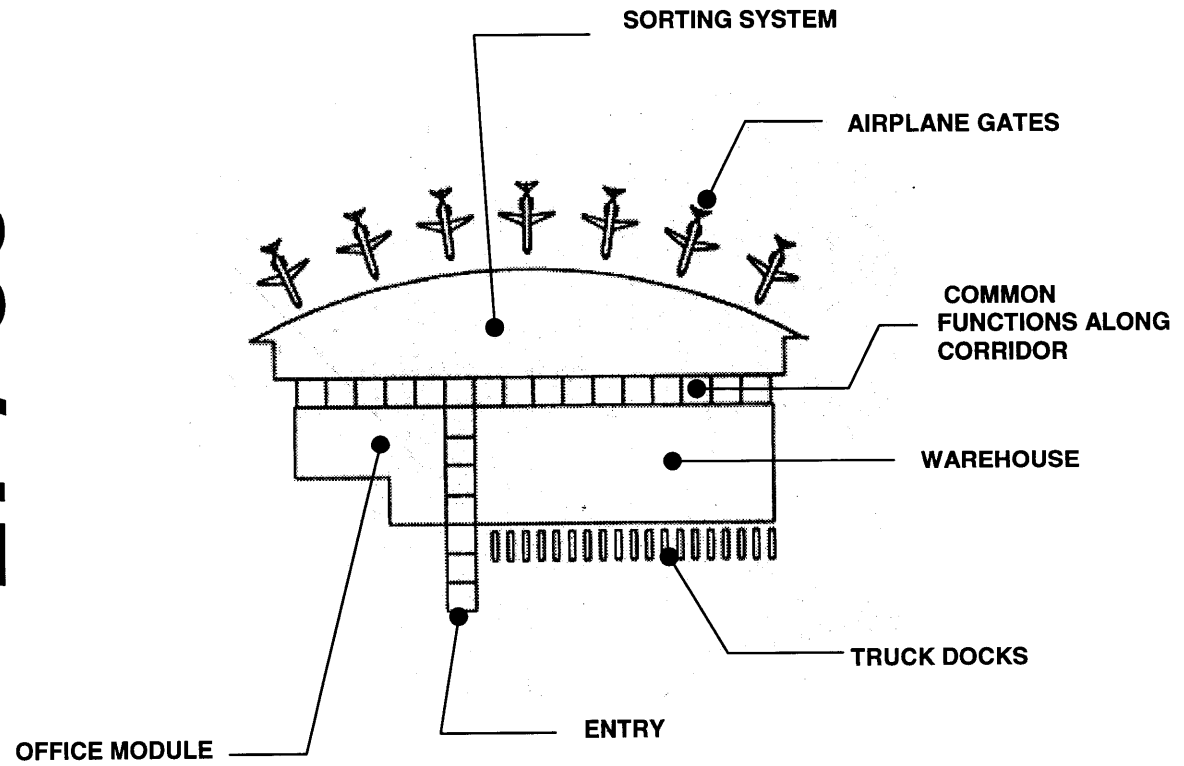
Although the separation of the major parts of the program into districts allows each district to expand at its own rate, it doesn't allow for a total experience of the facility and the functions at any one time. It is also possible that the groups will be separated to the point that they will have no interaction with each other while 'on the clock' and will not experience and understand what each group is doing and how each group performs its duties.

This scheme also creates an L-shaped sort path and leaves some airplane gates 'around the corner' from the main axis of the overall sorting system, which is not ideal.

On the plus side, the linear dock allows easy access for the trucks and the concave aircraft ramp provides additional space between airplanes.

Scheme 2

27 / 50



Scheme **3** incorporated an office tower between a curved airline gate system and a curved truck dock system. The sorting system, as well as much of the personnel activities, were to be in the open area between the aircraft and the trucks.

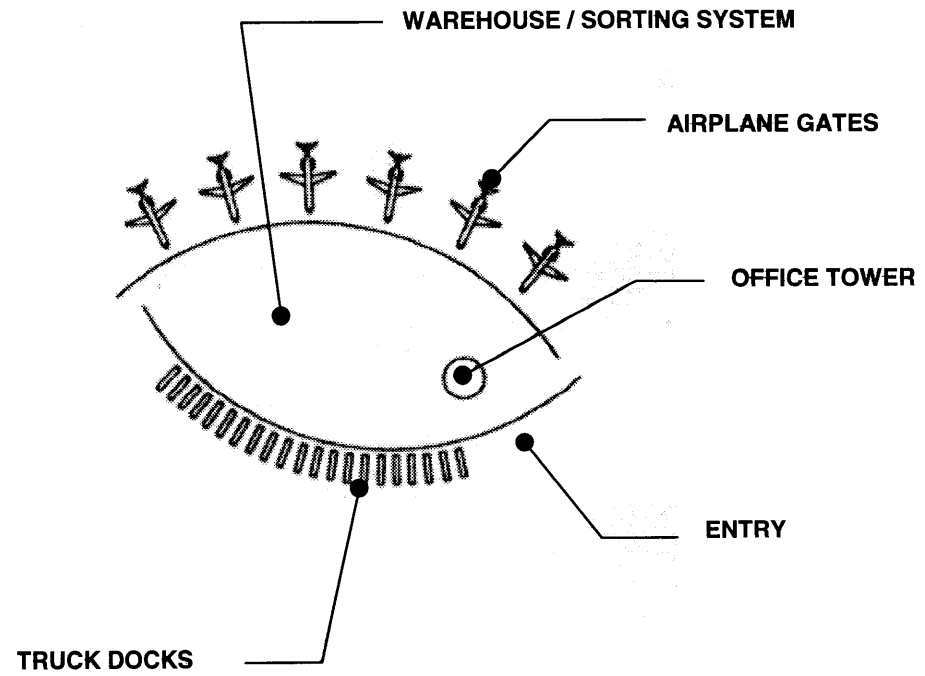
The office tower would provide good views of much of the facility and would serve as a focal point for the interior and exterior activities. The tower would contain all the administrative functions, as well as the common functions. The common functions would be situated in the upper portions of the tower where the tower would extend beyond the roof, allowing the employees to figuratively 'leave' the facility during breaks and other down time.

The sorting system in this scheme would be somewhat compromised with the varying distances between truck and plane. The relationship of truck to plane can be good or bad, depending on which gate and dock you are analyzing. The 'shapes' of the spaces from office tower to airplane gate, as well as airplane gate to truck dock, which would potentially contain like-functions, would be pie-shaped and of varying acute and obtuse angles. These were unacceptable conditions.

The overall shape of the facility also created a closed system and would little or no ability to expand.

Scheme 3

28 / 50



Scheme **4** used two non-parallel curved walls to enclose the facility, one providing an edge for airplane gates and the other for truck docks. The office, administration, support and common functions were housed in one block located at the smaller end of the facility.

The curved wall for the airplane gates works well because the wall is convex relative to the aircraft approach. The truck dock, on the other hand, does not work because the trucks are approaching a concave wall, which makes arriving and departing difficult.

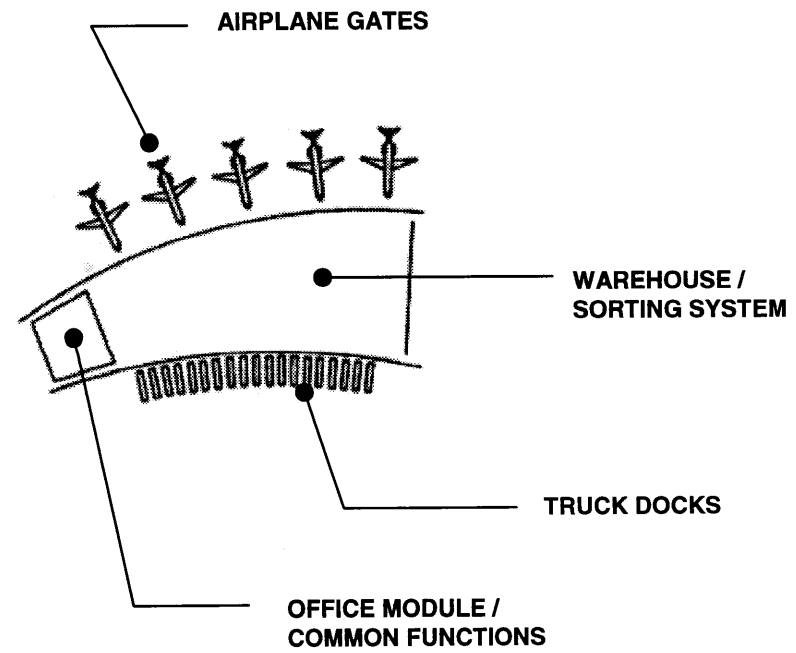
In this scheme, the sorting system would fare better due to the more direct relationship between the airplanes and trucks. Because the walls ‘flare’ away from each other at the end of the facility that is opposite the office block, the distances between plane and truck would vary; this could create a hierarchical condition that would not be conducive to a new team-based organization.

Views to and from the office block are good only to about half of the planes and trucks. The large distances between the office block and the planes and trucks at the far end of the facility do not allow a good level of quick interaction between the personnel and management.

Expansion in this layout is possible away from the office block, but the problems mentioned in the above paragraph would become even more amplified.

Scheme 4

29 / 50



Scheme **5** incorporates a half-circle plan to organize the major pieces of the program. The airplane gates are distributed along a curved wall and the truck docks along a straight wall, both good conditions. The office block is centrally located as the focal point of the facility.

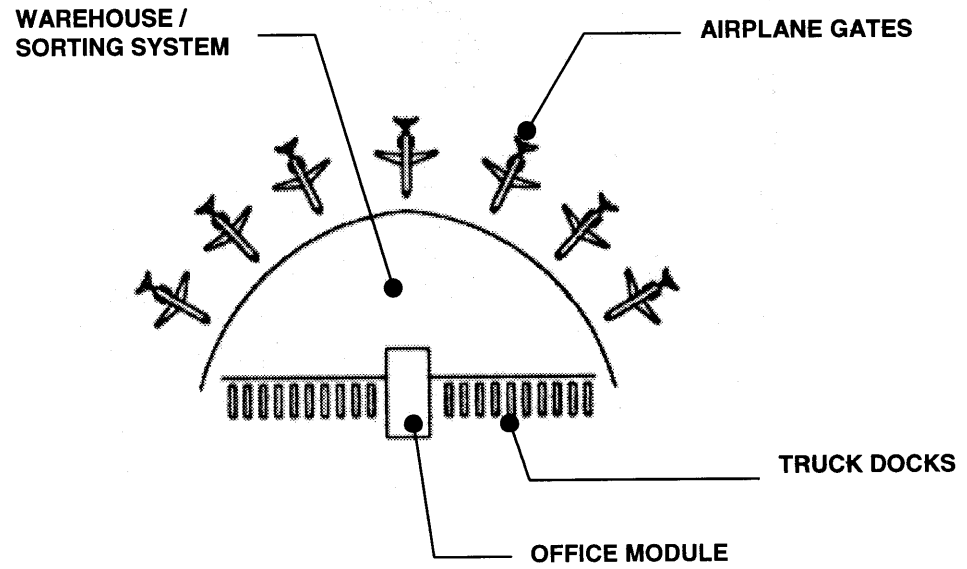
The centrally located office block has excellent views to and from each airplane gate, but has little or no view to the truck docks. However, the fact that the office block bisects the truck dock system creates shorter distances to and from the extreme ends of the facility.

The interior of the facility would rely on a compromised half-radial sorting system, which could prevent ideal package flows. Also, the subdivision of interior space into equal pieces for a team organization would create pie-shaped groupings, which would also create less than ideal conditions for a streamlined distribution process.

In terms of expansion, this facility is basically a closed system, but a new facility could be mirrored some distance away from the truck dock axis, creating one full-circle facility.

Scheme 5

29 / 50



Scheme **6** is a two-level parti where the airplane gates are on level one and the truck docks are on level two. The warehouse and sorting system would occupy two levels, distributing the packages both vertically and horizontally. The office block would be a one-level space on level two and would look down into the warehouse area.

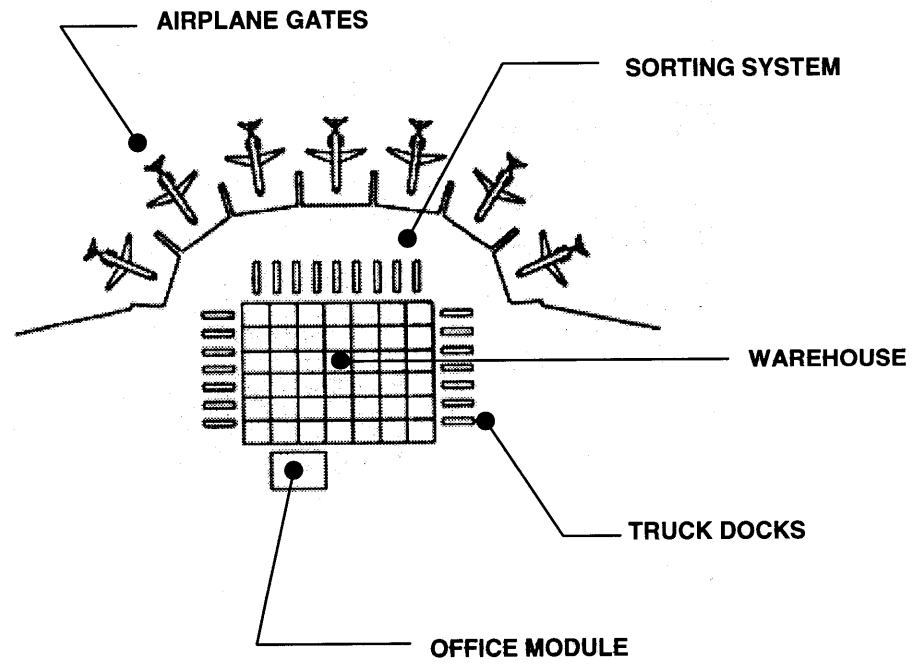
Because the office block is so detached from the airplane gates, little physical and visual connection would be possible – an undesirable situation. However, there would be a good connection with the warehouse, sorting system, and all truck docks.

As the truck docks are on an orthogonal system and the airplane gates more or less radial, there are potential conflicts in resolving the sorting system, i.e. creating a smooth transition between the two geometries.

One unique feature of this proposal is that it offers a covered area between each airplane gate and the warehouse. This would protect employees and equipment from poor weather conditions, as well as providing a storage / parking area for the ramp equipment.

Scheme 6

34 / 50



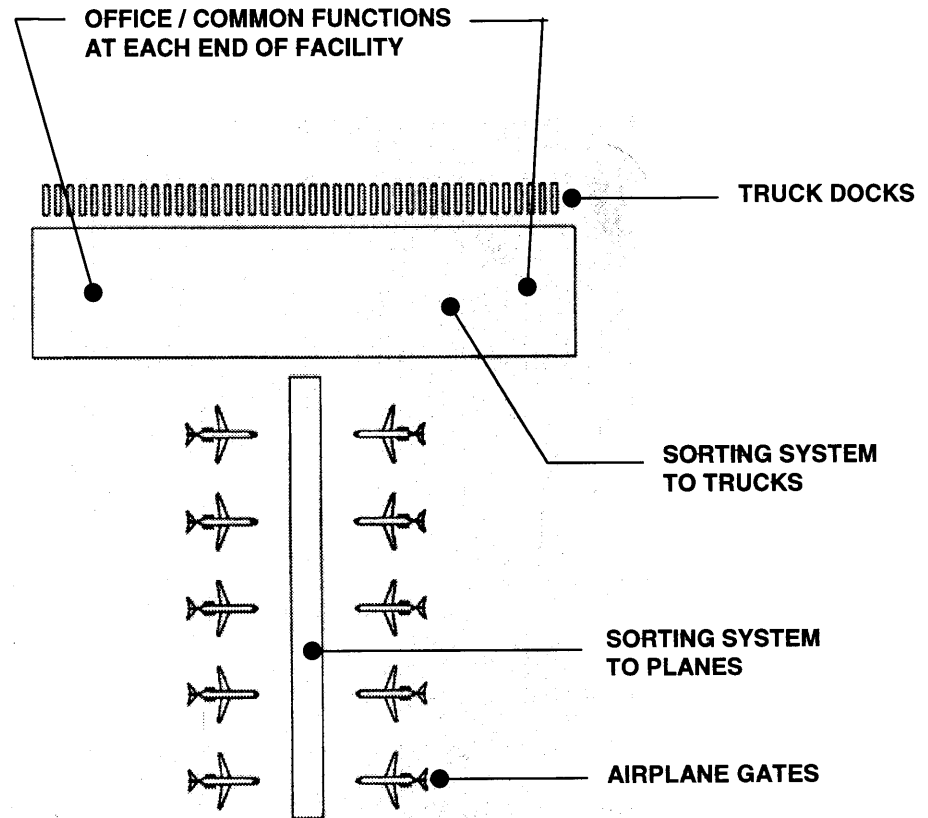
Scheme **7** has a lot of advantages in terms of its expandability. Each major part of the program has been isolated into separate districts, allowing them to easily expand at their own rate. The office module has now been separated into two districts (office module 1 and office module 2), creating a balance between management access to the warehouse floor and necessary space for the sorting system. By having these two office modules working together, the facility can be better managed at its center and its edges. The layout also succeeds in maximizing the number of airplane gates and truck docks.

The airplane gate system is of particular interest because it provides a potential efficiency in terms of shared equipment. Airplanes that face each other or are side by side could be staged in and out of their gates so that a team of personnel could move back and forth between gates.

One drawback in this scheme, however, is the distance between the truck sort and the airplane sort. This distance, even with the separation of management into two districts, could be too far to be effectively managed. Also, this scheme suggests a departmental organization rather than a true team-based organization.

Scheme 7

35 / 50



Scheme **8** incorporates a linear truck dock system and a circular airplane gate system, linked by sorting system 'bridge'. The scheme also separates the office module into two pieces, distributing the management and common functions across a larger portion of the facility.

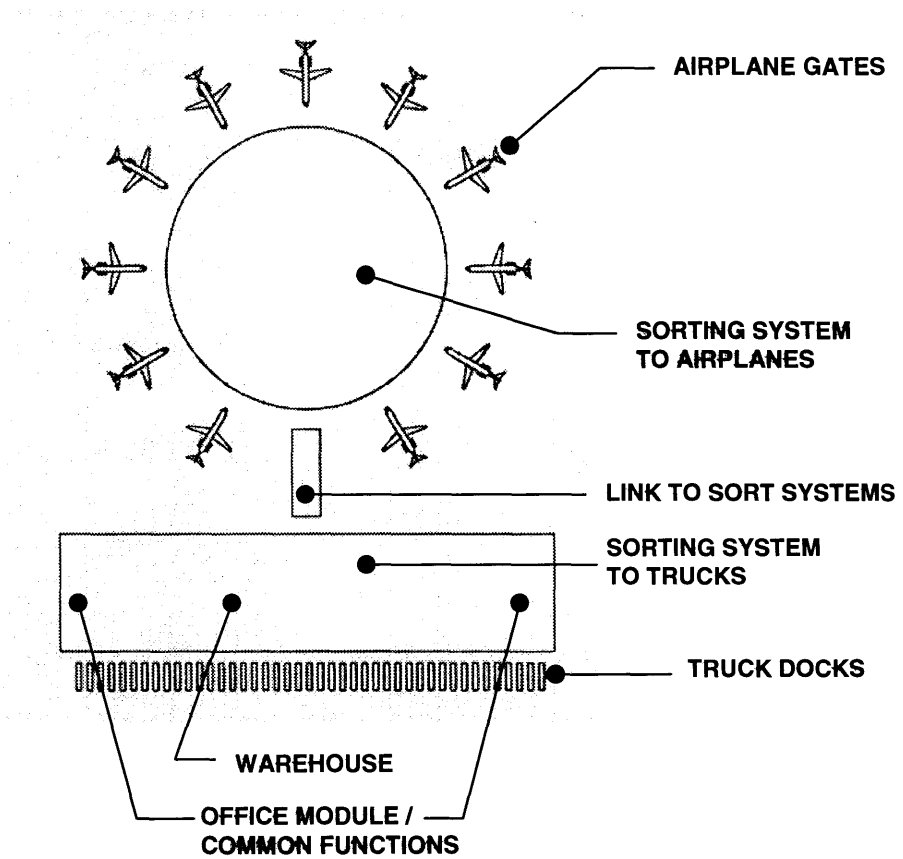
The facility has some strong and weak points in terms of expansion. The rectilinear portion of the facility, i.e. the truck docks, the truck warehouse, and office modules, can be easily expanded due to its open system. But the circular airplane gate layout creates a closed system without the ability to expand.

Views and access from the office module to the truck docks are very good, as well as to the truck warehouse area, but views from the office module to the airplane gates are not always ideal. Some gates are out of sight and would prevent immediate management attention.

Also, by organizing the airplane gates in a circular fashion, a large circle is formed and is probably too much space for this program to fill. One could argue successfully that there would be a lot of waste in proceeding with that portion of this scheme.

Scheme 8

36 / 50



Scheme **9** is a rectilinear layout that provides a strong direct relationship between the truck docks and the airplane gates. The office module has again been separated into module 1 and module 2, minimizing the distances between facility activities, personnel, and management.

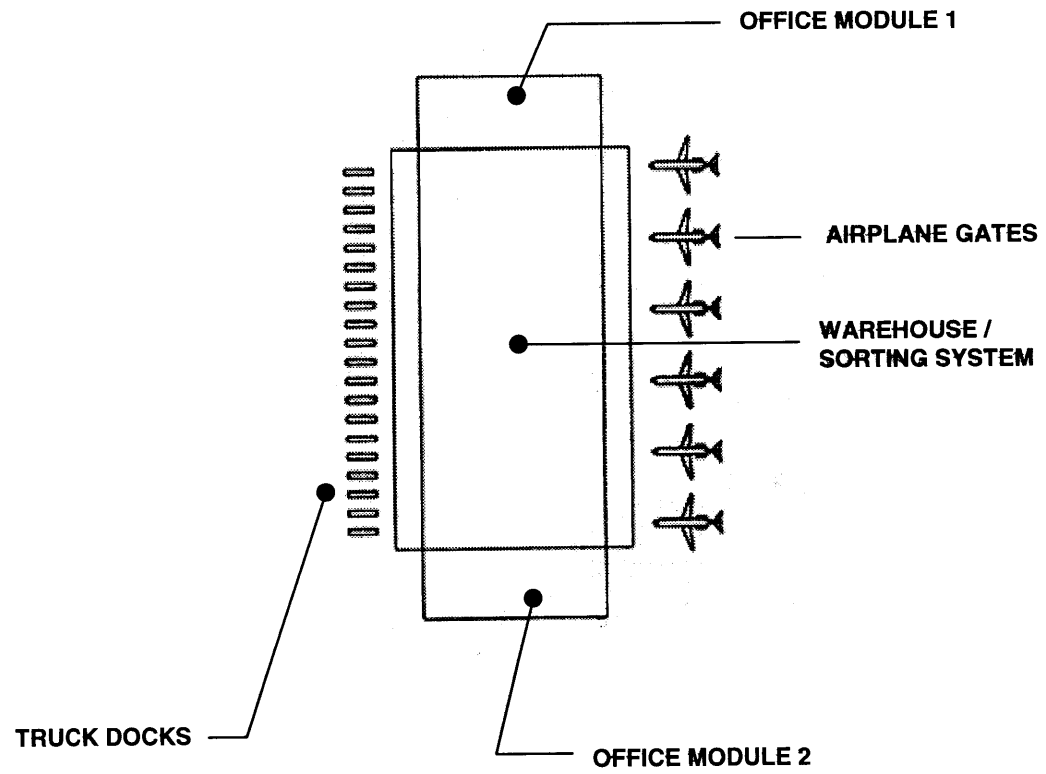
Views are good from all parts of the facility for both management and personnel. Also, the potential for a more team-based organization is possible in this scheme, as the facility could be subdivided into smaller rectangles that would span from truck dock to airplane gate.

Expansion in this scheme would probably be difficult based on the part as is. The positions of the office modules prevent any growth by either the truck docks or the airplane gates.

This scheme also doesn't maximize very well the amount of truck docks and airplane gates, but the gains in sorting efficiency due to the proximity of trucks and airplanes to the sorting system might be enough to proceed with this layout.

Scheme 9

39 / 50



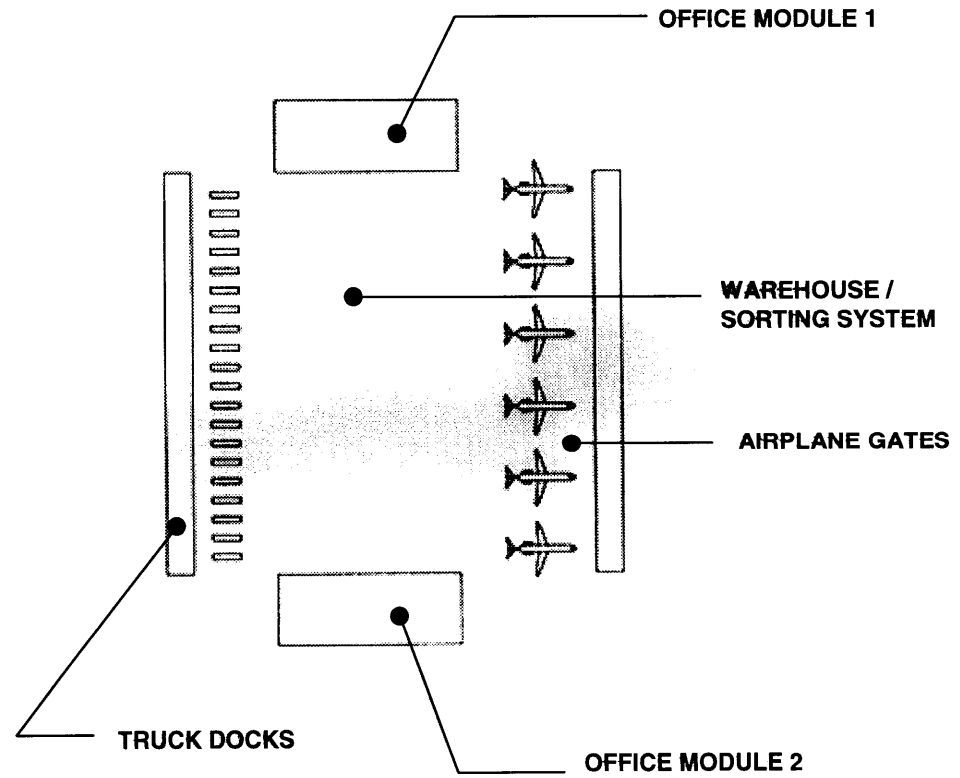
Scheme **10** is very similar to scheme 9, but this one allows the major pieces of the program to be separate and more easily expanded. The office module has also been separated into two pieces for better management capabilities.

The relationship of truck to plane is also similar. It is still a direct, close distance to and from the sorting system, but in this case, the trucks and planes have been placed 'inside' the facility, as opposed to outside of it. This would obviously make arrival and departure difficult for the different vehicles, but could be advantageous in terms of protection from weather conditions.

The fact that the vehicles are 'inside' the facility would also allow better observation of the sorting system to and from the vehicles. The status of a given airplane gate, for example, could be immediately determined from the warehouse floor.

Scheme 10

39 / 50



Scheme **11** is a long, thin rectilinear scheme that maximizes the number of airplanes gates and truck docks, as well as minimizing the distance between airplanes and trucks.

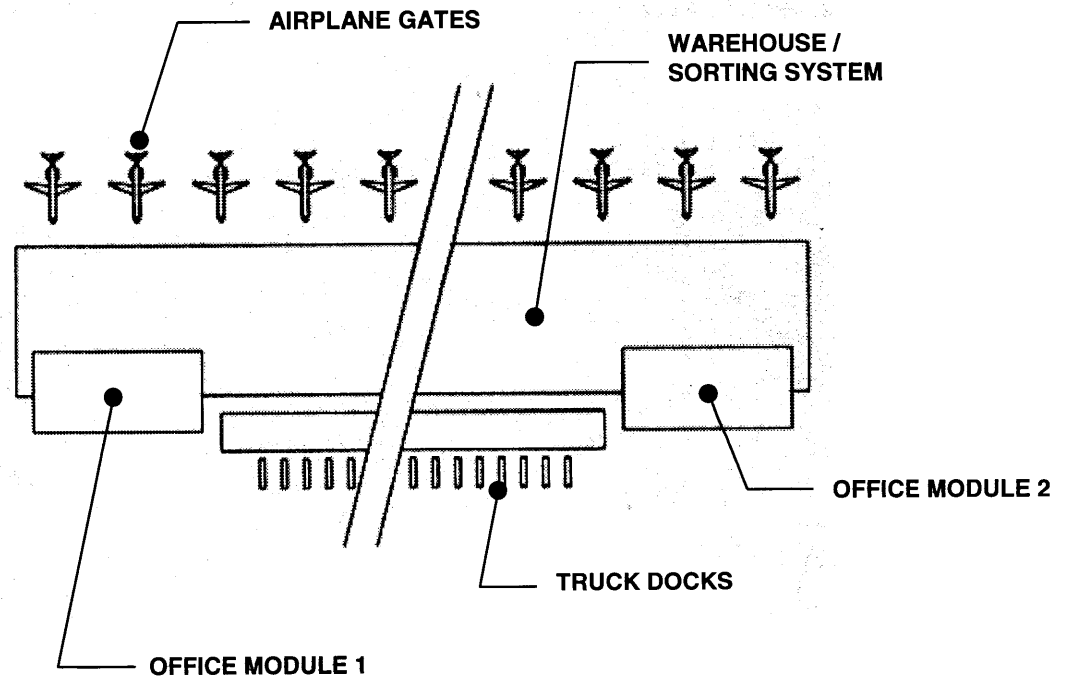
The office module is again separated into two, but they are much farther apart this time. This would maximize the distance to the center of the facility to and from the office module, making access to the offices and common functions more difficult and time consuming.

The sight lines from the office modules to the warehouse and airplane gates are good, but could be better toward the truck docks. The trucks in the center of the dock are almost completely out of sight.

Expansion in this scheme is good, as each of the major pieces of the program is allowed to exist independently.

Scheme 11

40 / 50



Scheme **12** is a very unique scheme, relative to the others in this list of fifteen, in that it incorporates a pure radial design to solve the program. Rings and wedges creates zones to which different functions can be assigned. This scheme, due to its overall symmetry, would be very indicative of a team-based organization.

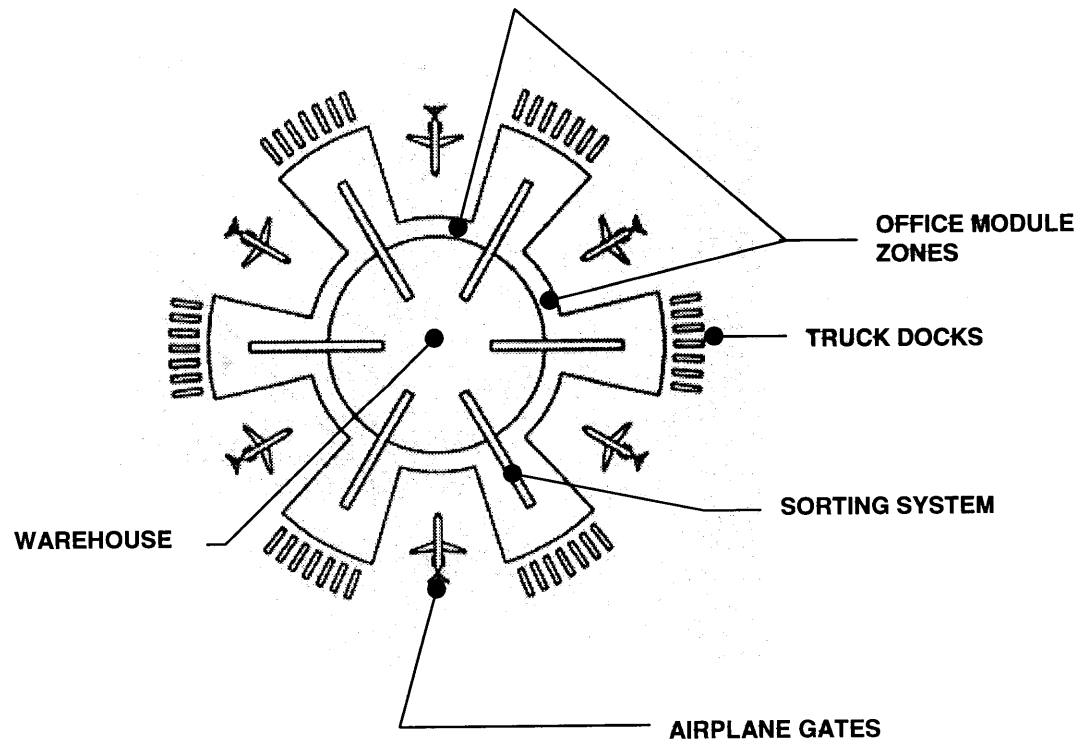
From the center of the facility, views could be had of all airplane gates and truck docks, as well as the sorting system itself. This would allow quick and efficient management and personnel interaction.

At the center, the sort system would collect, sort, and distribute packages to the periphery through extensions to each gate and dock area. The distance to the airplane gates is minimized by bringing the airplanes more to the interior of the facility, enabling efficient use of equipment and time.

A drawback to this scheme is in the limitations of expansion. The overall design is a closed system that would have to be repeated in its entirety in order to add more gates and dock space.

Scheme 12

42 / 50



Scheme **13** divides the entire program into team-based modules, creating a potentially efficient and engaging system in which to work. Each airplane gate is paired with a series of truck docks, between which the personnel would perform the various facility functions.

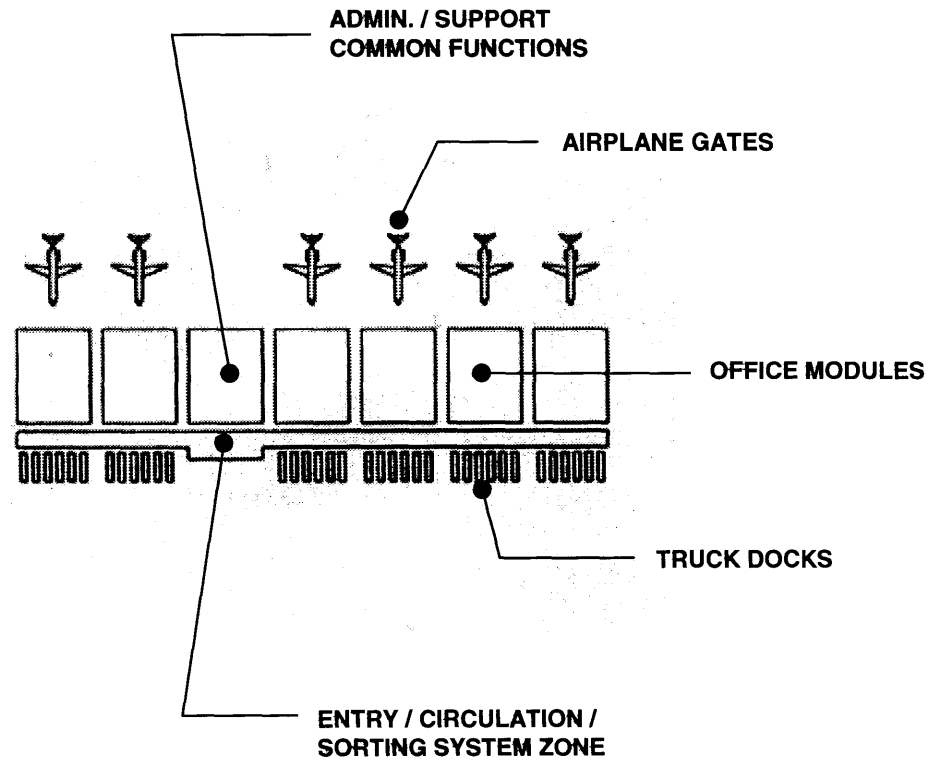
The sorting system would happen along a spine located between the modules and the truck docks. This spine would also be the connecting piece for all the modules, providing circulation for personnel. As the distances are small from plane to sorting system to truck, there are many advantages, such as allowing quick management attention, small distances to travel for personnel, immediate views of a module's particular sorting status, etc.

Expandability in this system is excellent, as the pieces of the program are not only allowed to grow at their own rate, but the separation into team-based modules dictates a controllable, planned expansion.

The office and common spaces occupy one of the modules near the center of the overall design, in order to provide a 'home' module for the entire facility.

Scheme 13

44 / 50

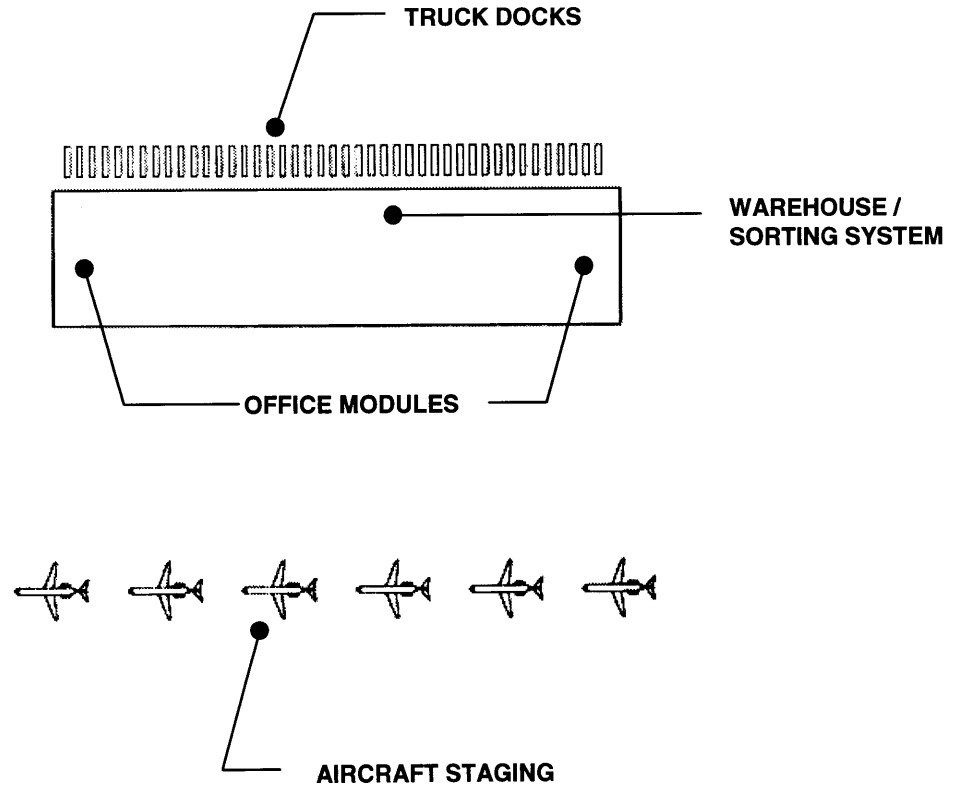


Scheme **14** uses a combination of two office modules, one warehouse / sorting area, and an aircraft staging plan to solve the program requirements. The separation of aircraft from the main warehouse allows more aircraft to be engaged at one time, but places the operations at those airplanes a good distance from the office modules. This could add additional time into the overall system of managing the sorting process.

The separation of the trucks and planes also involves the resolution of two distinct sorting methods. In one system, the package moves directly from the belts and rollers into position on or near a given truck. In the other system, the package moves from the belts and rollers into a temporary position on a vehicle that then takes the package out to the aircraft ramp. This second system could be very inefficient; but there may, however, be a reduction in costs with the exclusion of airplane gates.

Scheme 14

44 / 50



Scheme **15** is similar to scheme thirteen in that it divides the program into a series of team-based modules, but this time the office and common functions are separated into their own area. This allows two distinct types of spaces to be created.

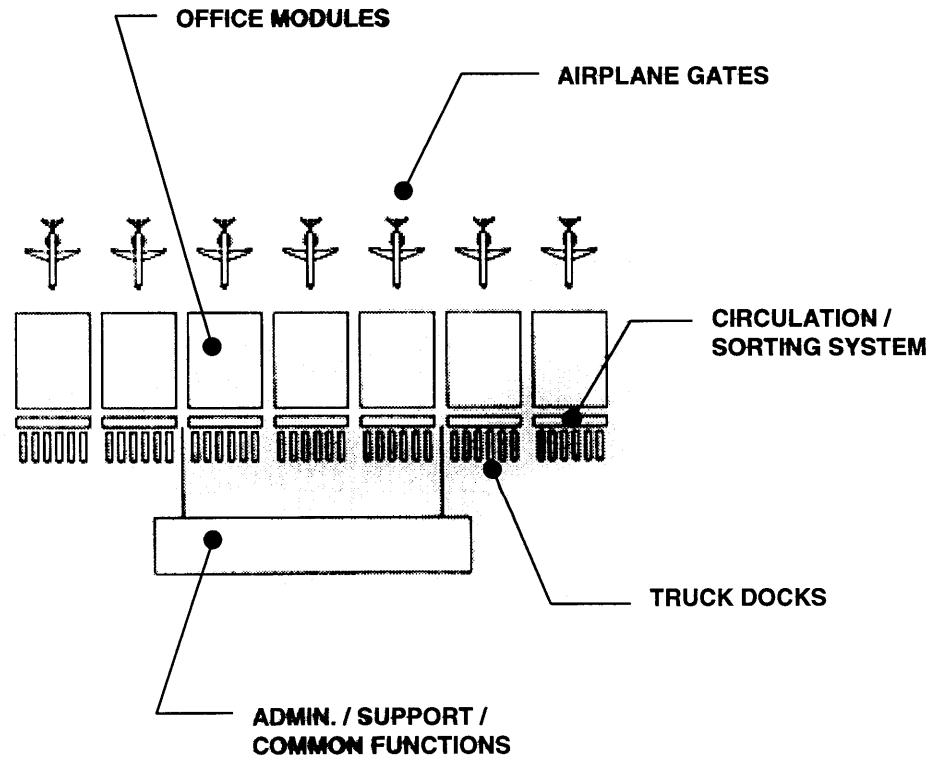
The separate area for office and common function would house the break rooms, conference rooms, meeting rooms, training rooms, and cafeteria. Administrative and other support function would also be located here.

Within each team-based module, views and access to airplanes, trucks, sorting system, etc. are maximized, creating a potentially efficient and well-managed organization.

Expansion is also maximized in this scheme through a *kit-of-parts* approach to programming and design.

Scheme 15

47 / 50



THE DESIGN SOLUTION

At the conclusion of the analysis of the various alternatives, an 'inventory' of what worked well and what didn't work well was cataloged and used to proceed into the final design phase. The team-based, expandable module, with a separate area for the office, administrative, and common functions, (Scheme 15) was chosen as the scheme that had the most *potential*.

The module-based design afforded several advantages over the other schemes in terms of the expandability options, the ability to form a team-based organization, programming in an innovative manner, creating spaces that foster communication, creating a distinctive corporate image, and allowing light and ventilation into the interior spaces.

An expandable modular scheme usually describes a certain attitude toward the structure of a building. In this case, the module is a small architectural component in the overall scheme, allowing the facility to expand at a proper social and technical *rhythm*. Each module contains exactly the same program and can be described as the *lowest common denominator* of a FedEx facility, i.e. the architectural critical mass of a working FedEx sort system. The components of this critical mass and their respective social or technical assignment are listed in the following chart:

50 Employees	Social System
3 Office Managers and 1 Support Staff	
4 Ramp Agents and 3 Support Staff	
1 Team Training Area for 50 employees	
1 Executive Support Staff	
1 Break / Light Work Area for 38 employees	
1 Private Conference Room	
1 Semi-private Atrium	
2 Shared Kitchenette Areas	
2 Shared Vehicle Maintenance Areas	
2 Shared Aircraft Maintenance Areas	
1 DC-10 / 727 Aircraft Gate	Technical System
4 CTV (18-wheeler) Docks	
10 Walk-in Van Docks	
1 JIT Vertical Storage Wall for 108 Containers	
2 Container Storage Areas for 20 containers each	
2 Container Staging Areas for 60-80 containers	
1 Ramp Equipment Storage Area	
240' of Sorting System Race Track	
240' of People Mover System	

These components expand in a strict linear fashion directly from the common functions area (see page 81), creating a very long, thin building. The master plan initially calls for four modules and eventually expands the facility over time to a total of eight modules in length. With this expansion comes the addition of all of the above mentioned program, as well as potential expansion to the main administrative office area, i.e. common functions area. This module-based design also allows for the development of a highly efficient, team-based organization. Each module works as a unit that is part of a larger network, measured not only by its own efficiencies, but also by the efficiencies of the entire sorting process. Shared spaces between each module allow for the cross-fertilization of ideas and general interaction. The people mover system also allows cross-communication to happen, as well as providing quick access to and from each module and the main office area.

Visual communication also plays an important role in this scheme. As the scheme is very *transparent*, all aspects of the sorting system can be seen at any given time. With the addition of a management pod within each team module, the ability to forecast the sorting system status of each module is very easy. Also, there is quick and direct access and visibility to each respective aircraft and truck dock, personnel, as well as JIT storage. Every aspect of the system is exposed for *everyone* to become involved in, not just management. This allows FedEx to create a learning environment and to prepare its employees on a daily basis for a future position in management – a key to reducing turnover.

The sorting system equipment is also easily expandable by linking directly back into the existing main belt and roller infrastructure. The secondary belt system that links directly to the trucks and container staging areas can simply be attached where necessary. Additional belt capacity is built into the system through a two-level, race track belt design, which operates at approximately 240 ft/minute.

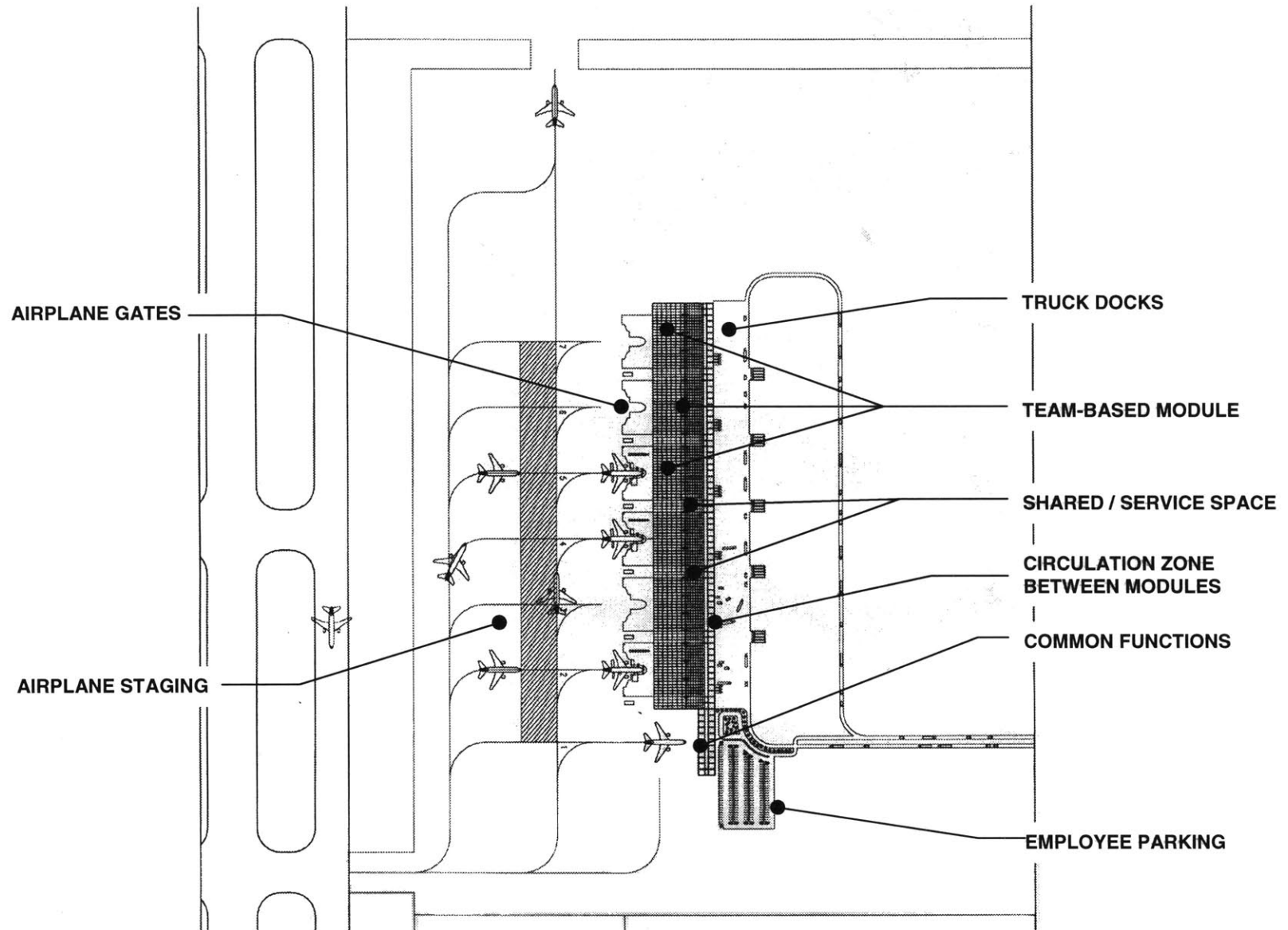
An innovative and unique feature of the design is the introduction of the JIT vertical storage wall as a solution to FedEx's search for a way of providing JIT service to its customers. The storage wall is an east-facing wall that provides an ever-changing façade to the traffic on the near streets, as well as Highway 35W. As the containers are pulled from and pushed into the wall, openings are created or filled allowing light into and out of the facility. During the evening hours, when the facility is at its busiest level, the lights within the facility will shine through to the outside, highlighting the JIT storage capacity. The transferring of containers by the mechanical lift would also be visible.

The facility is enclosed with a technologically advanced glazing system that allows natural light into the facility, but more importantly, allows clear views to the sky at night and the incoming airplanes. The glazing reflects much of the sun's ultraviolet rays and prevents excess heat gain to the interior spaces. The heat gain during the daytime hours is not much of a concern because the facility is basically down during those hours anyway. The majority of people working during the day are various administrative and support personnel who would be located in the common office area – a separate part of the facility.

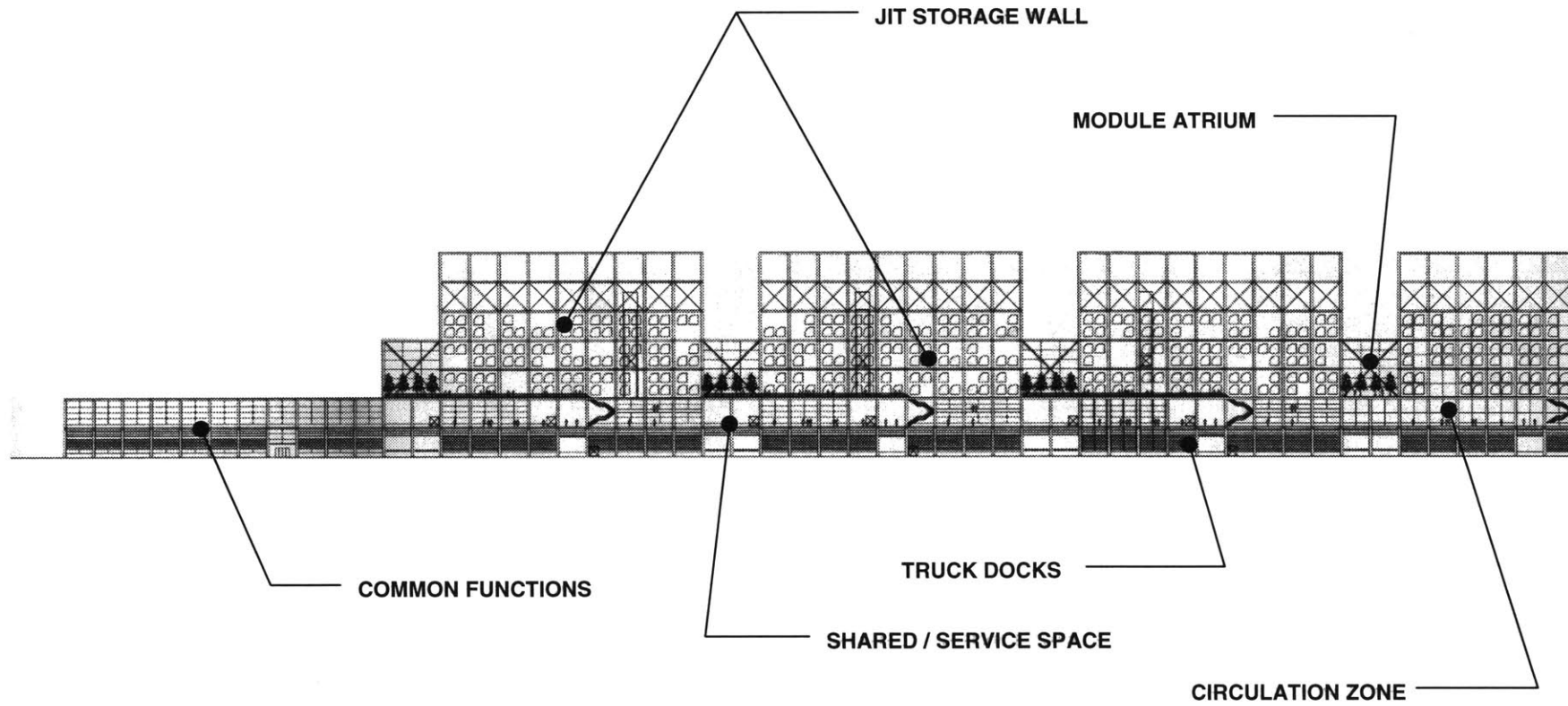
THE SOCIAL SYSTEM



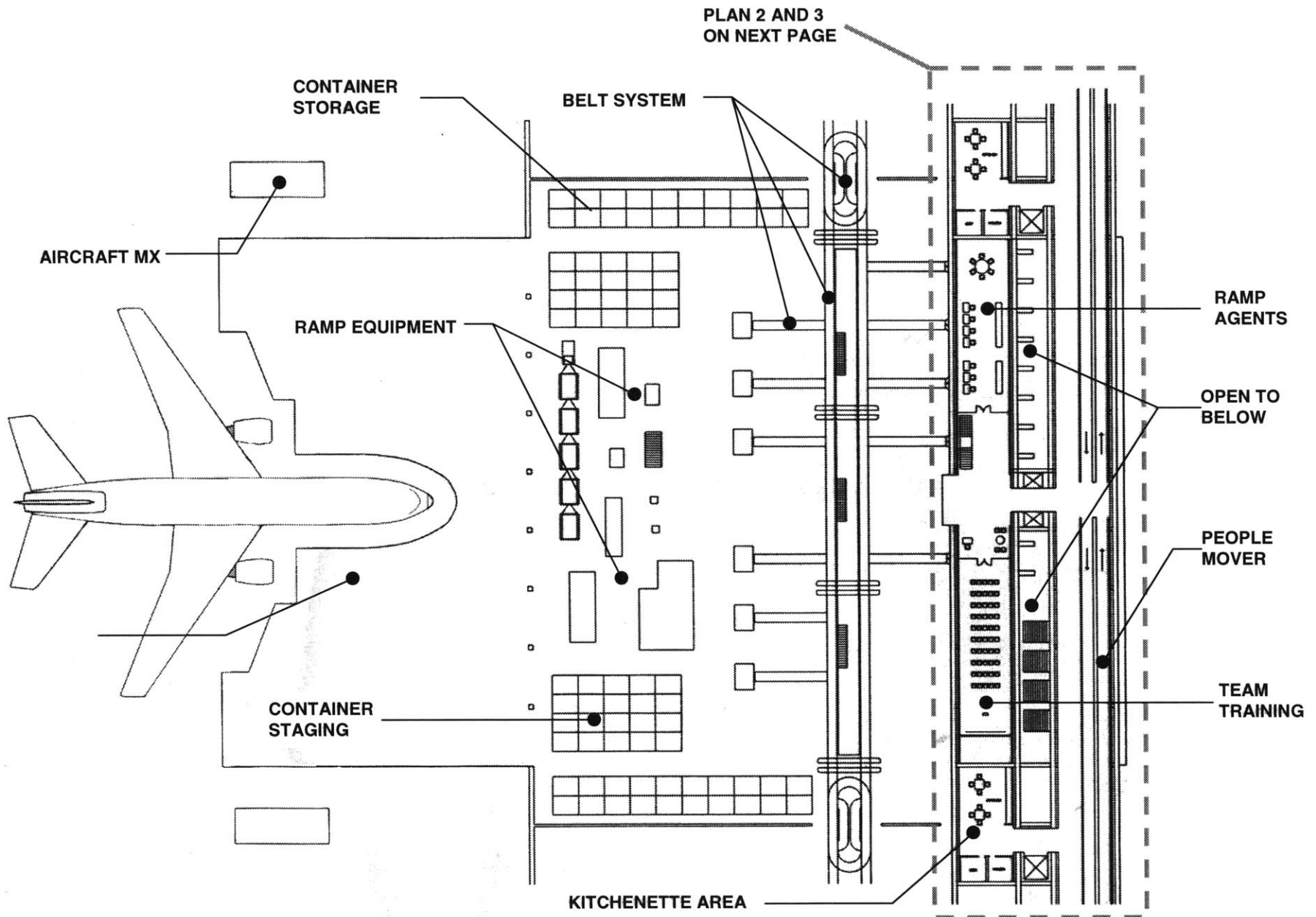
SITE PLAN



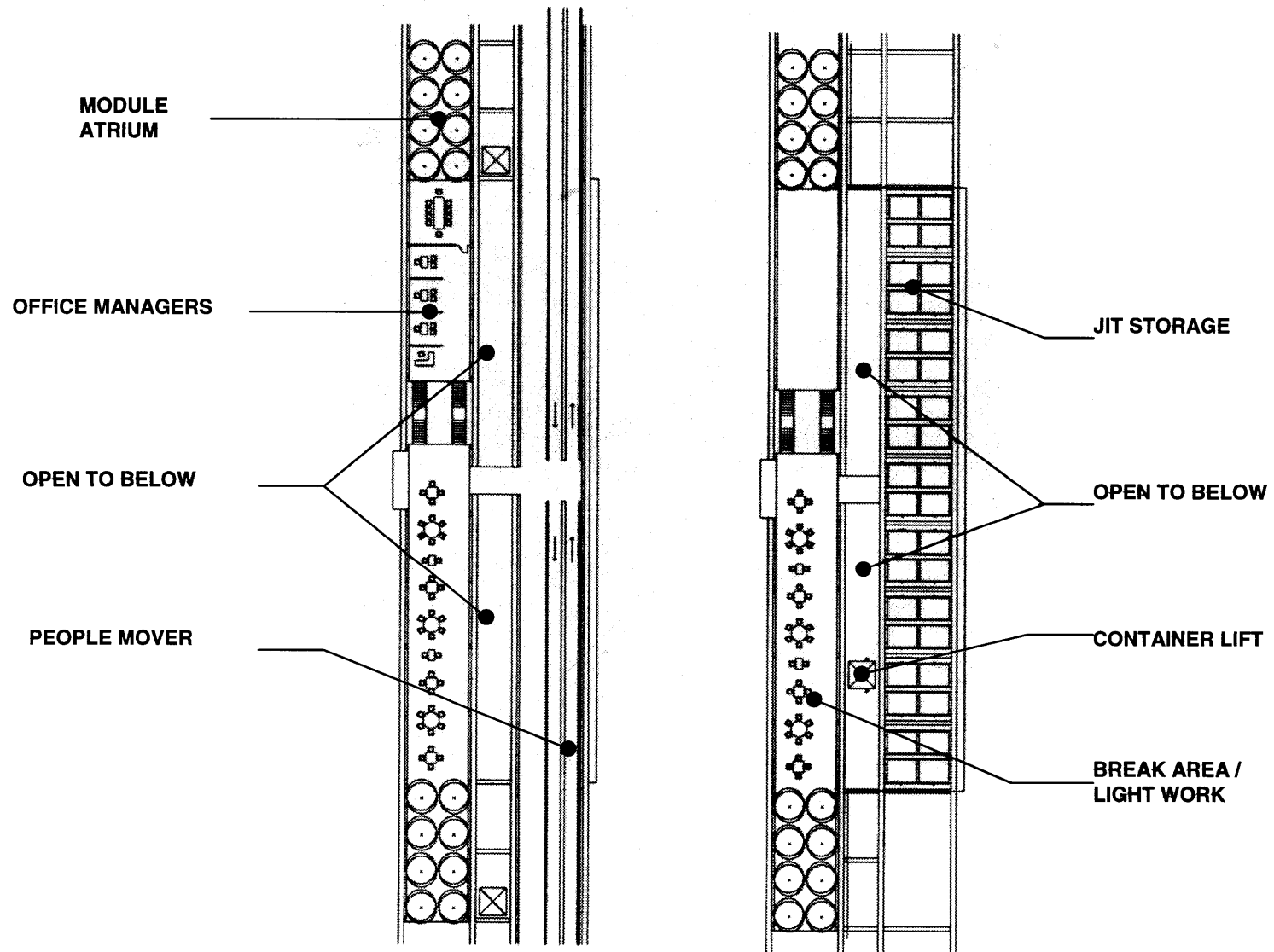
SITE ELEVATION



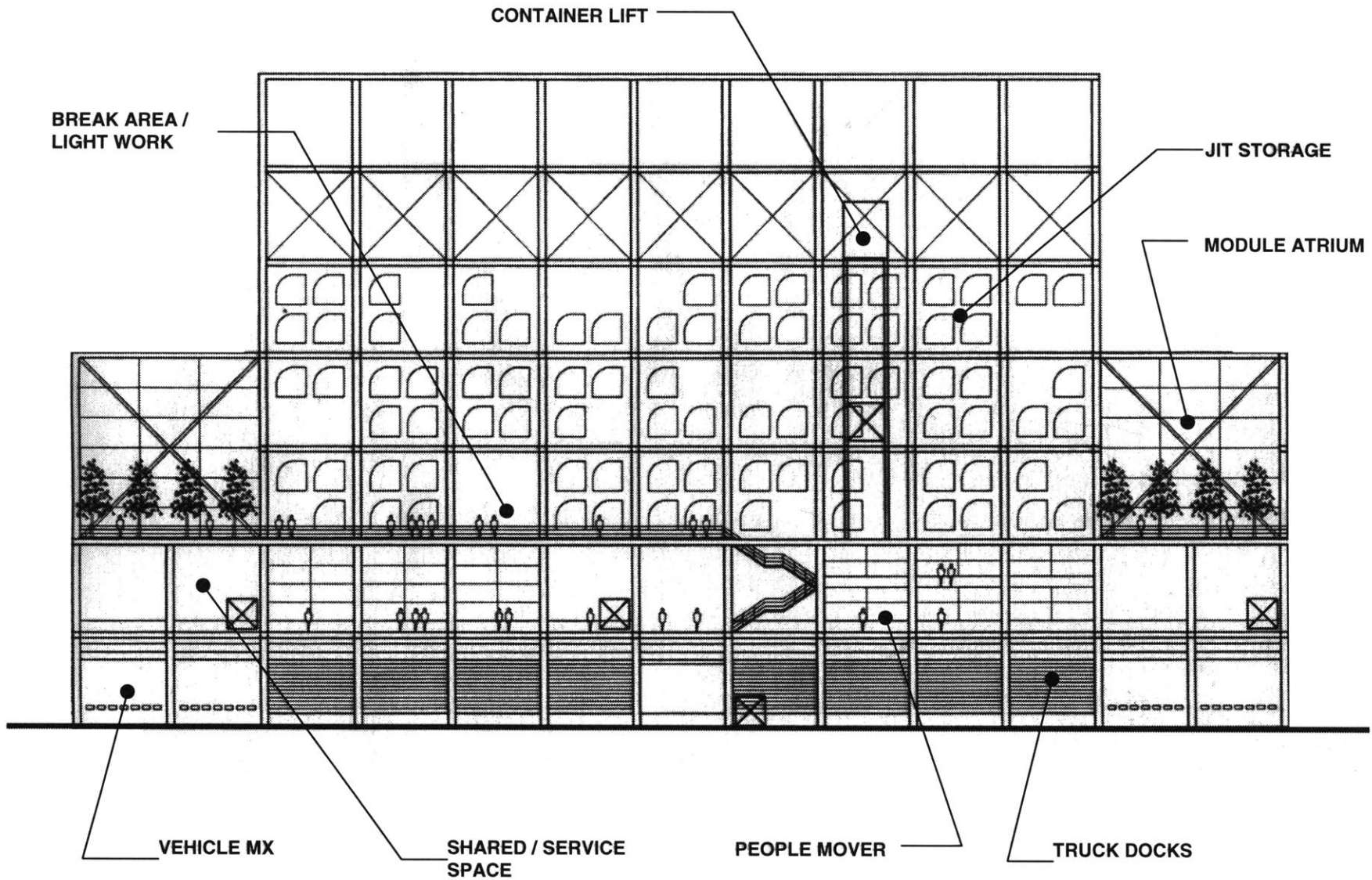
MODULE – PLAN 1



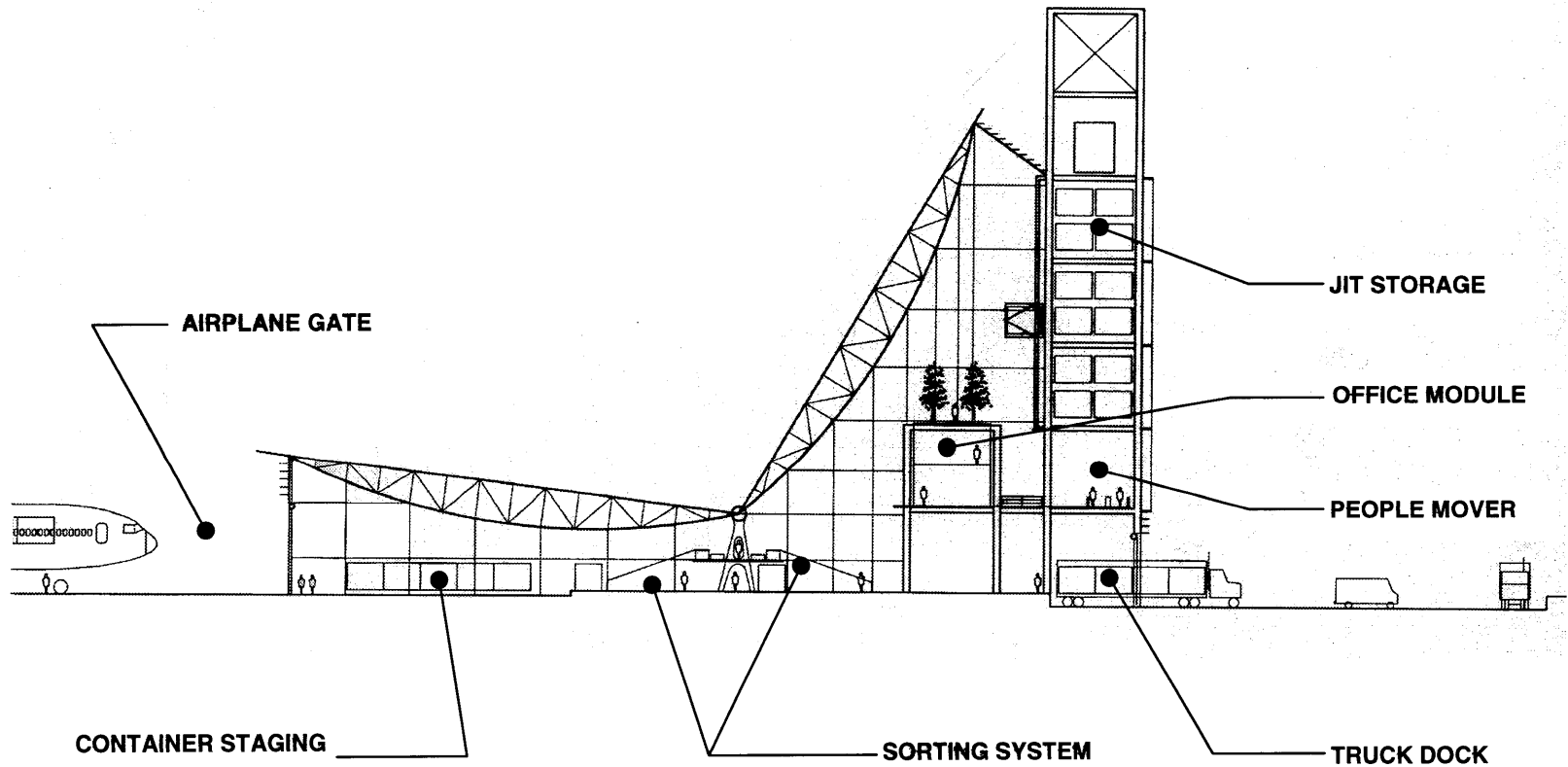
MODULE – PLAN 2 AND 3



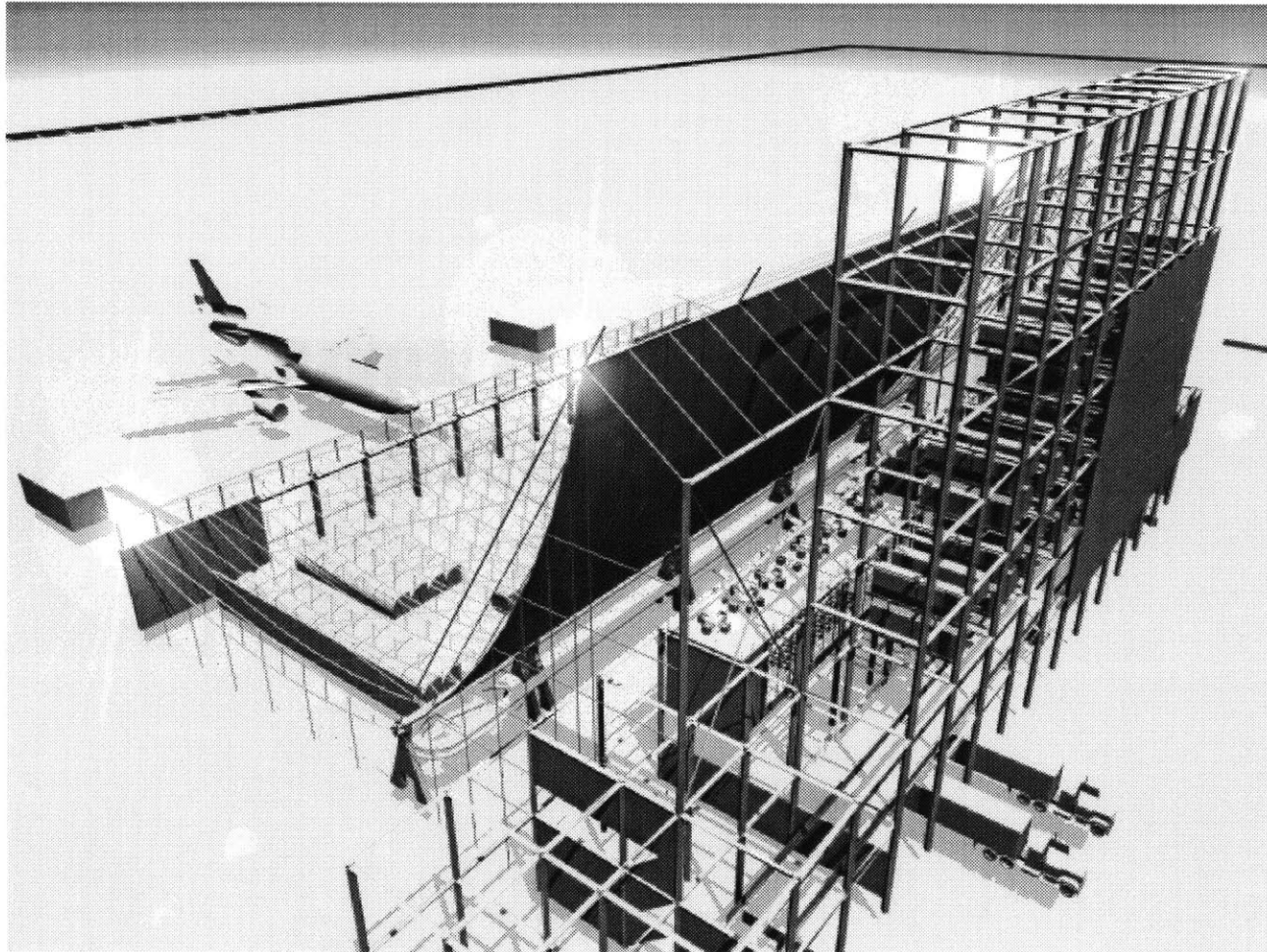
MODULE - ELEVATION



MODULE - SECTION



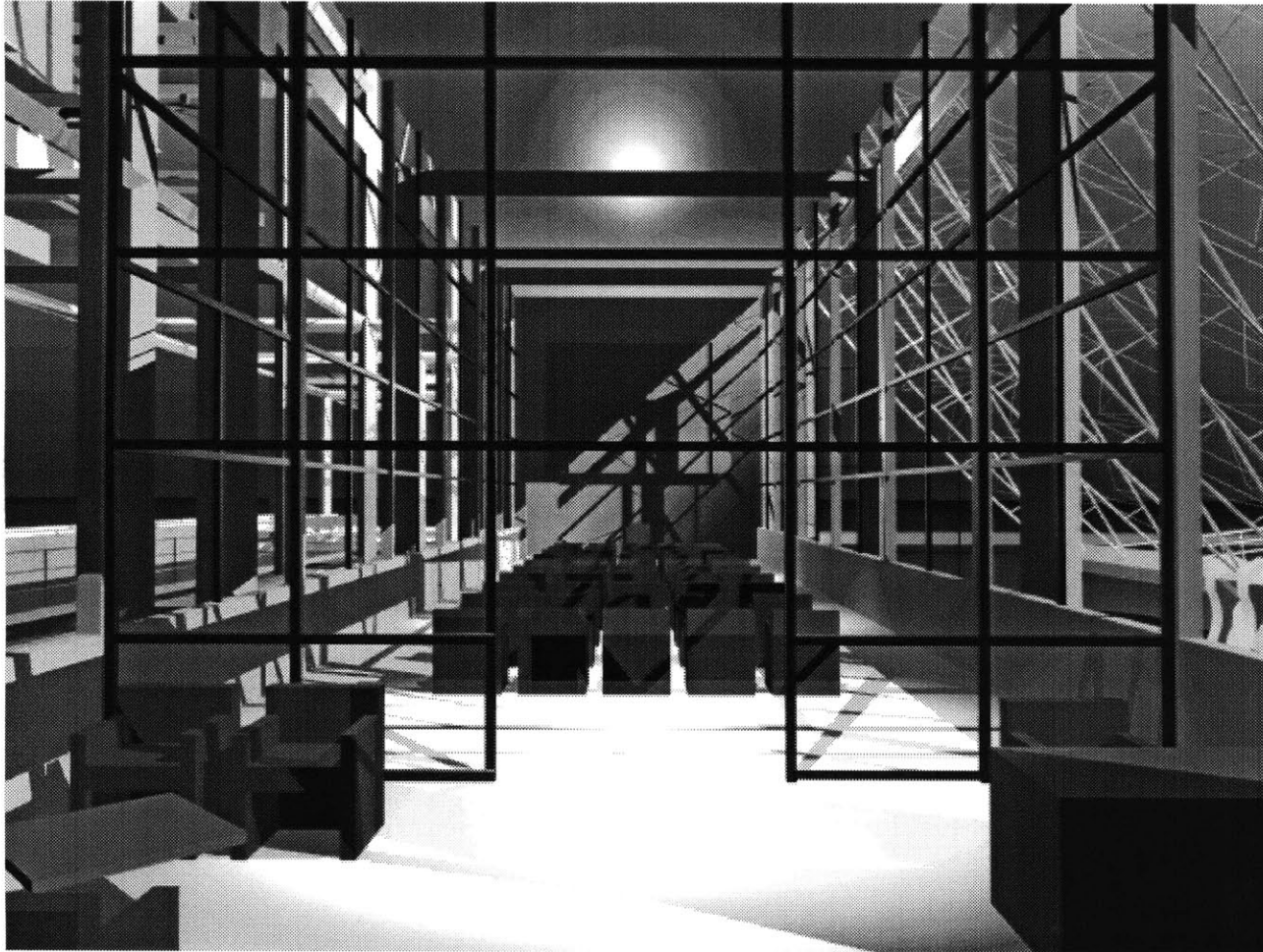
PERSPECTIVE INTO MODULE SECTION



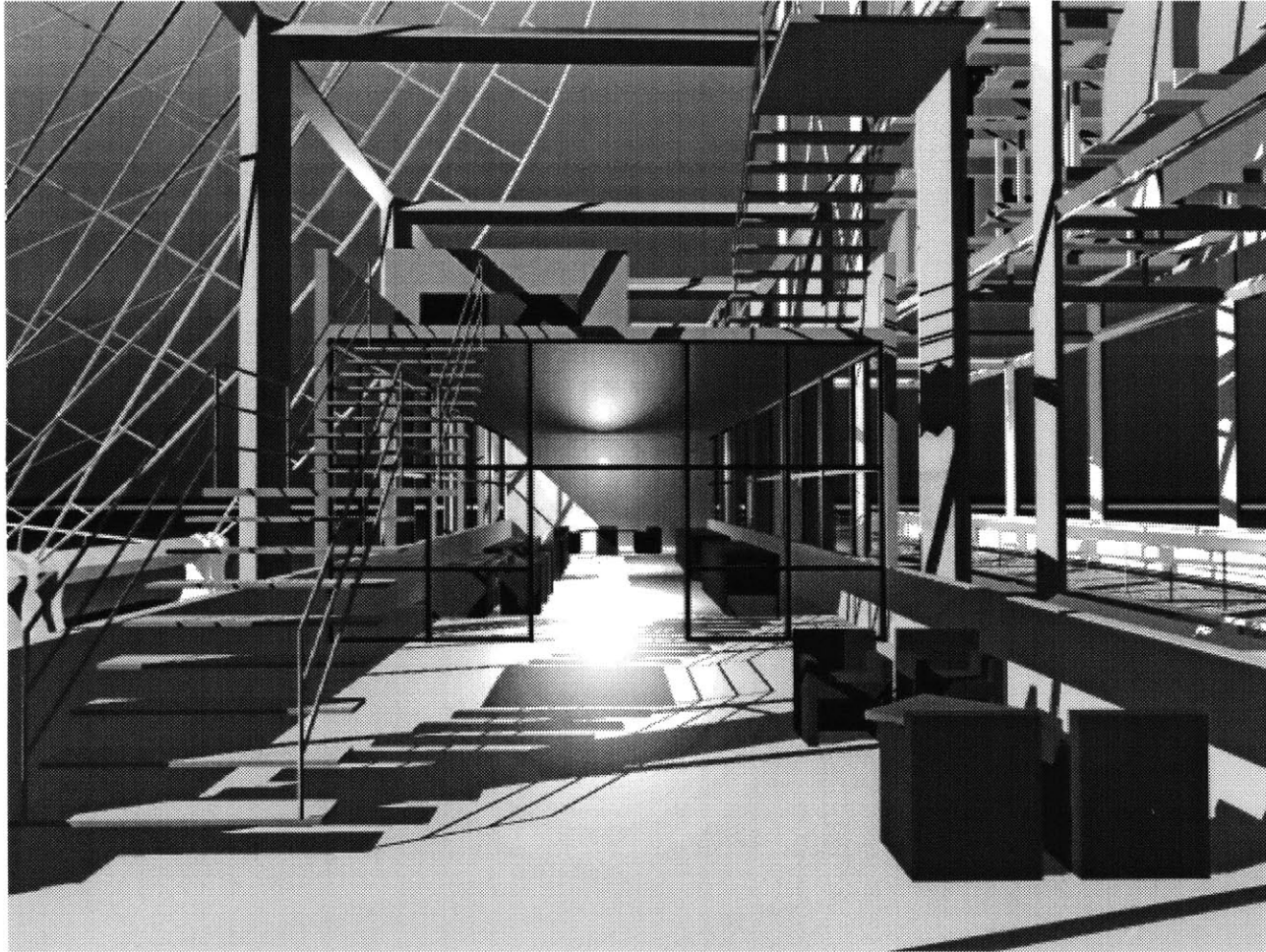
**VIEW FROM PEOPLE MOVER
INTO TEAM MODULE**



VIEW INTO TEAM TRAINING AREA



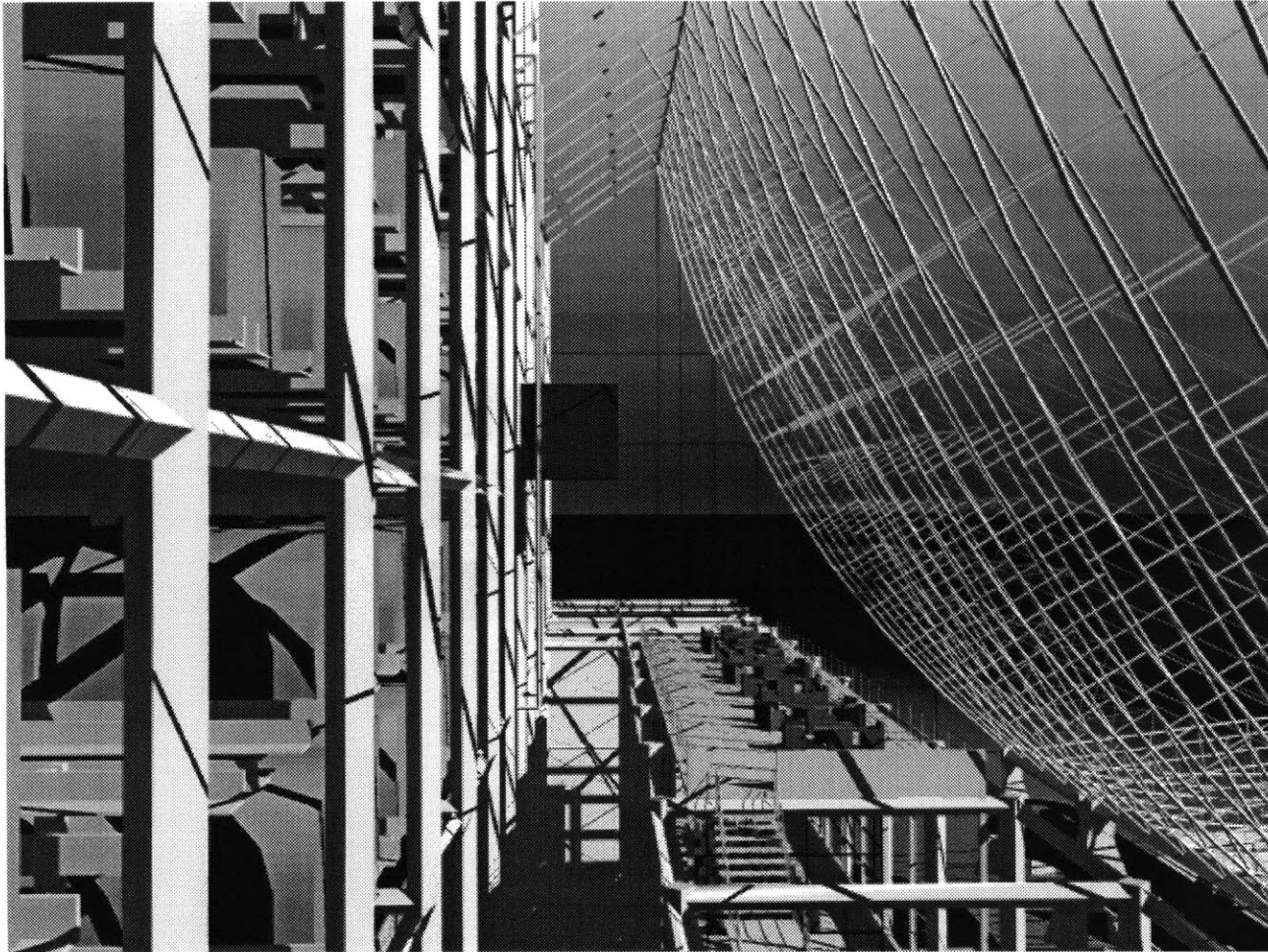
**VIEW OF LIGHT WORK AREA,
TEAM TRAINING AREA, AND
JIT STORAGE WALL**



**VIEW OF LIGHT WORK AREA,
JIT STORAGE WALL, AND
WAREHOUSE FLOOR**



**VIEW OF LIGHT WORK AREA,
JIT STORAGE WALL, AND
CONTAINER LIFT**



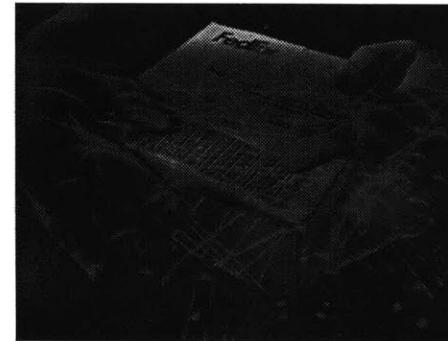
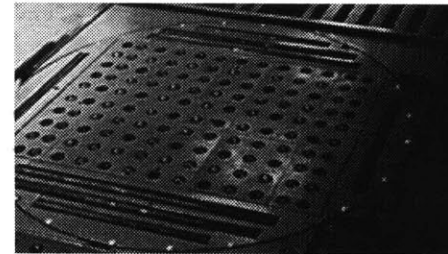
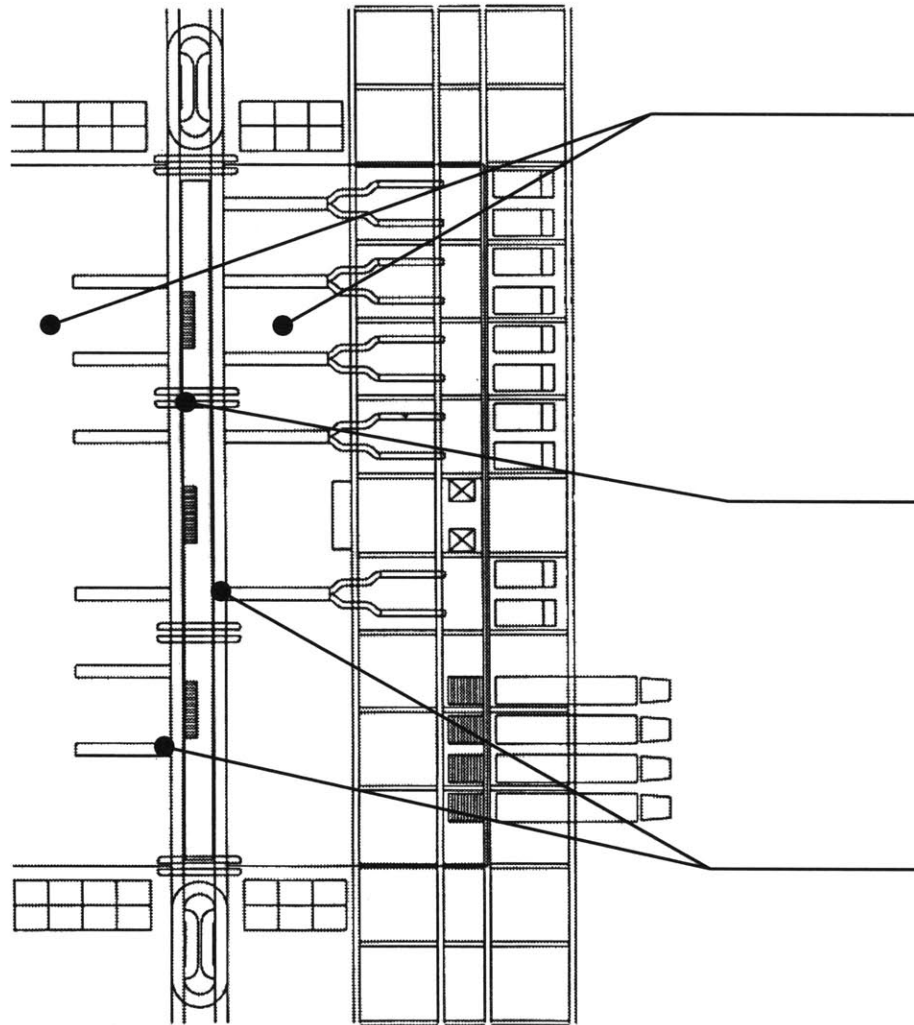
**VIEW OF TEAM TRAINING AREA,
MANAGEMENT OFFICES, AND
JIT STORAGE WALL**



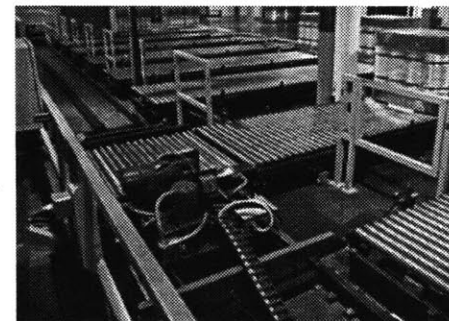
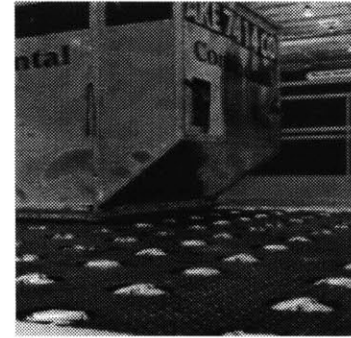
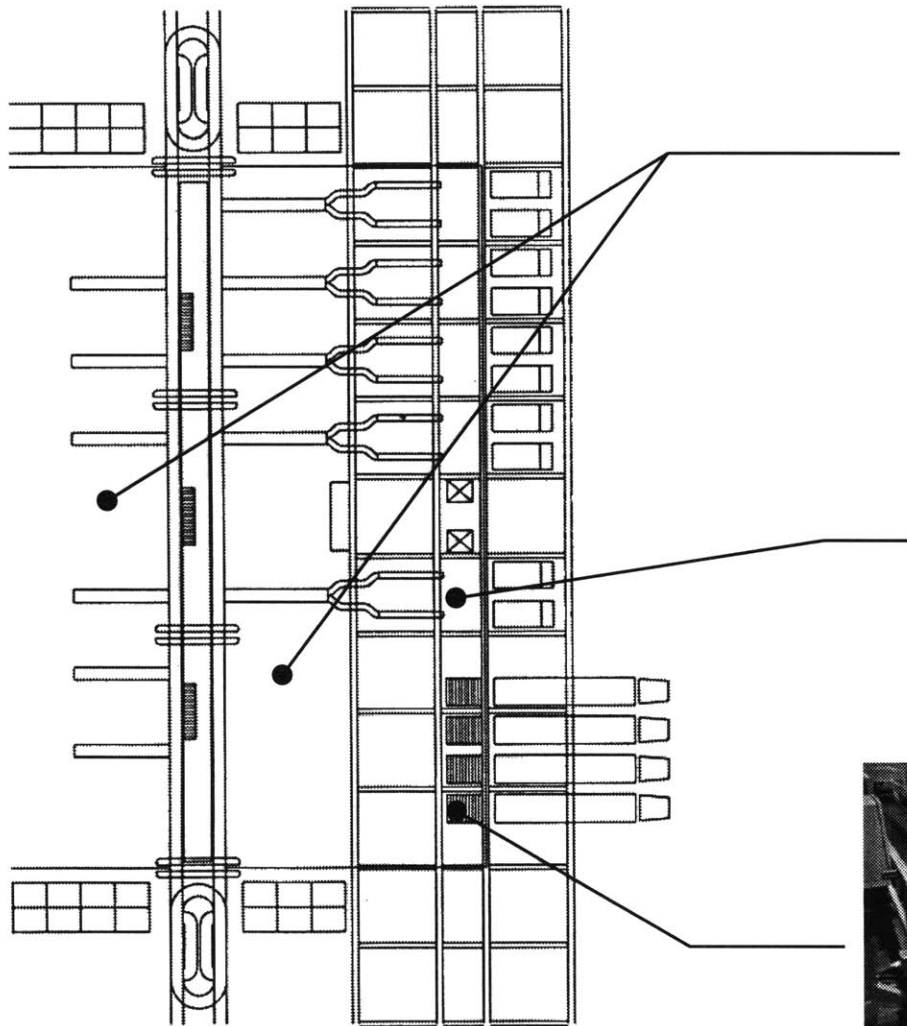
THE TECHNICAL SYSTEM



EXPRESS SORT

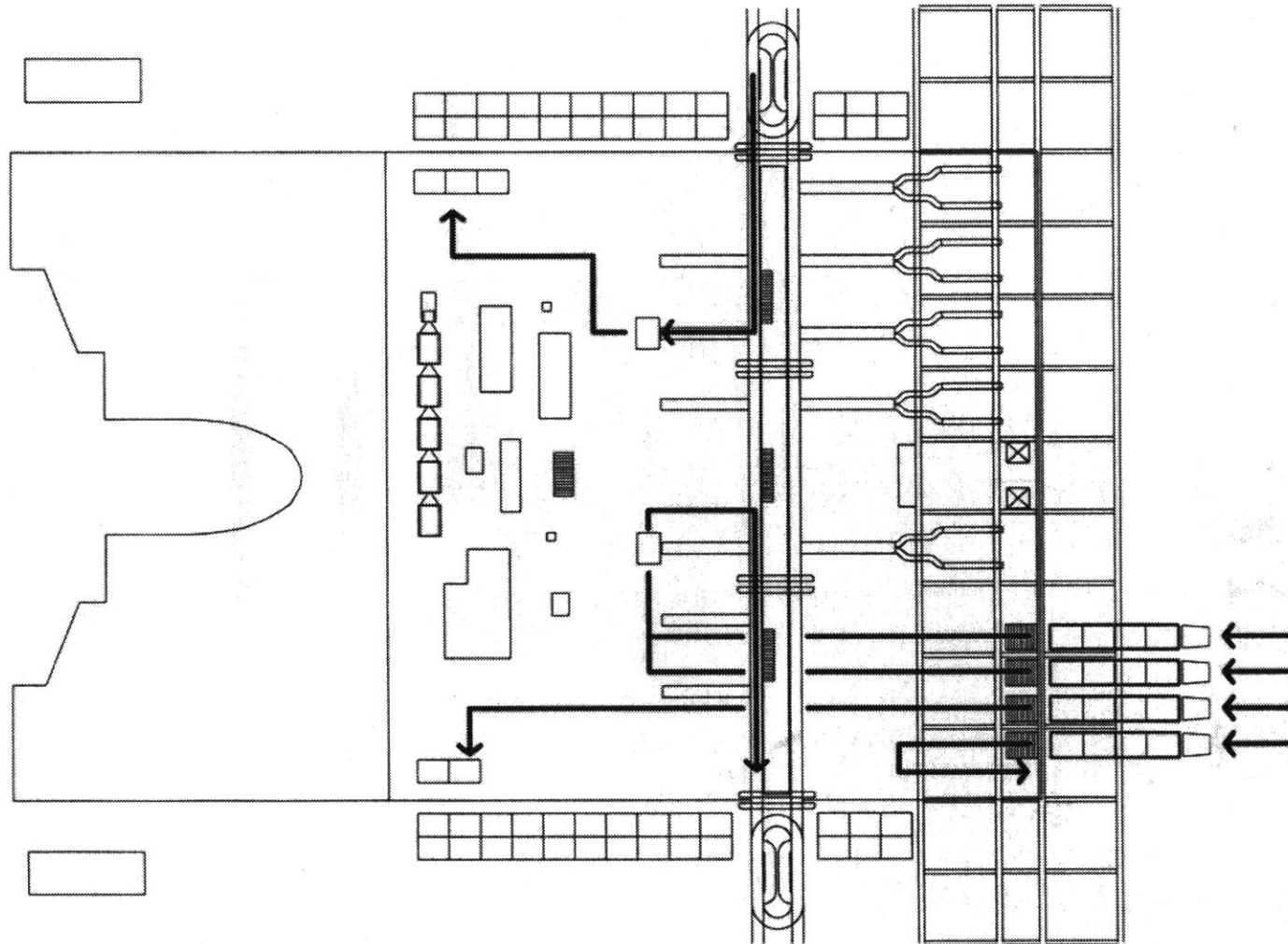


HEAVYWEIGHT SORT



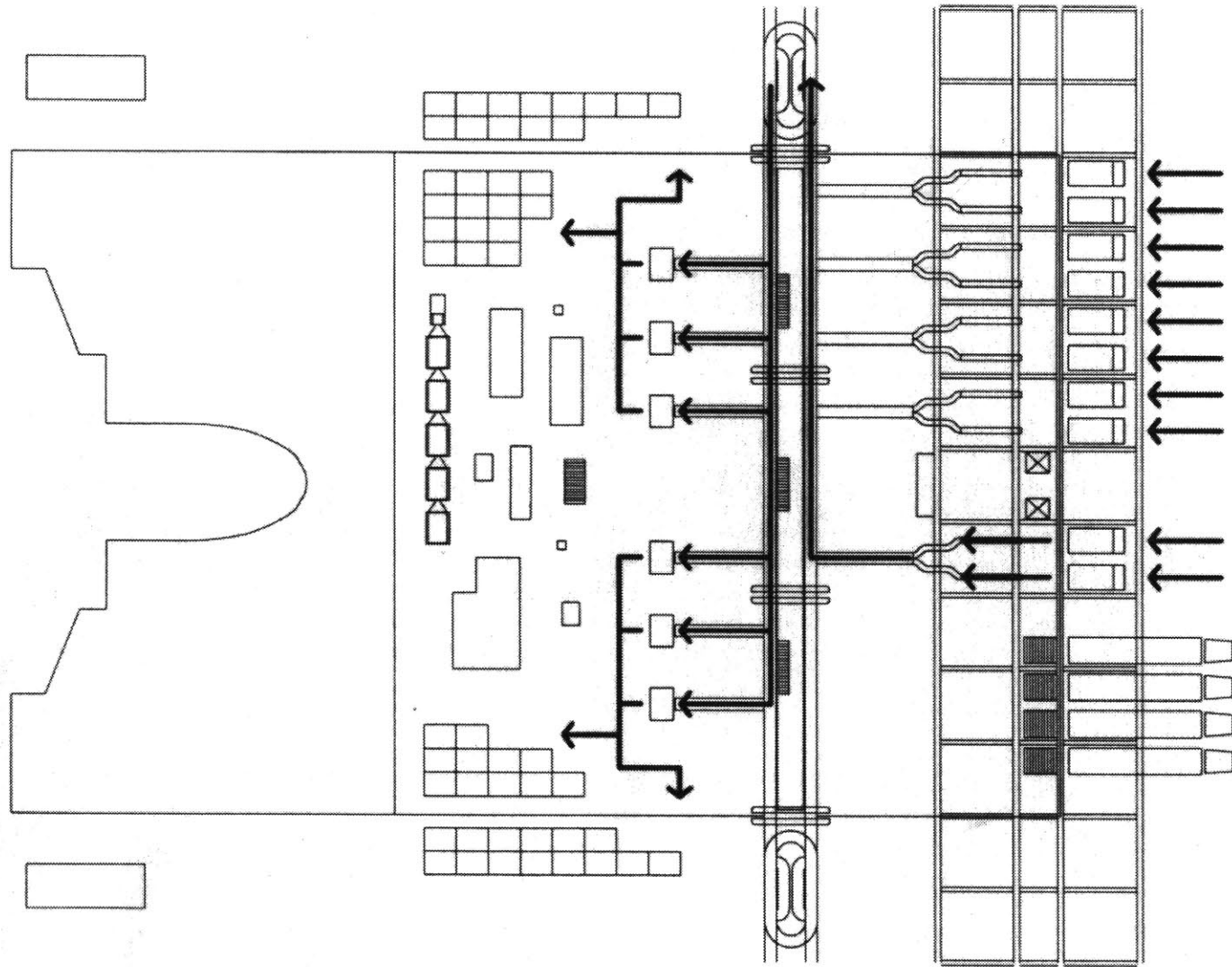
6:00 pm – 8:00 pm

The large CTV trucks (18-wheelers) enter the facility with 4 large 8' L x 11' W x 8' H containers each. These containers are either raised and placed in the JIT storage wall, moved into the container staging area, or moved to a sorting system belt extension, where the contents of the container are placed on the sort system's main belt and distributed throughout the facility.



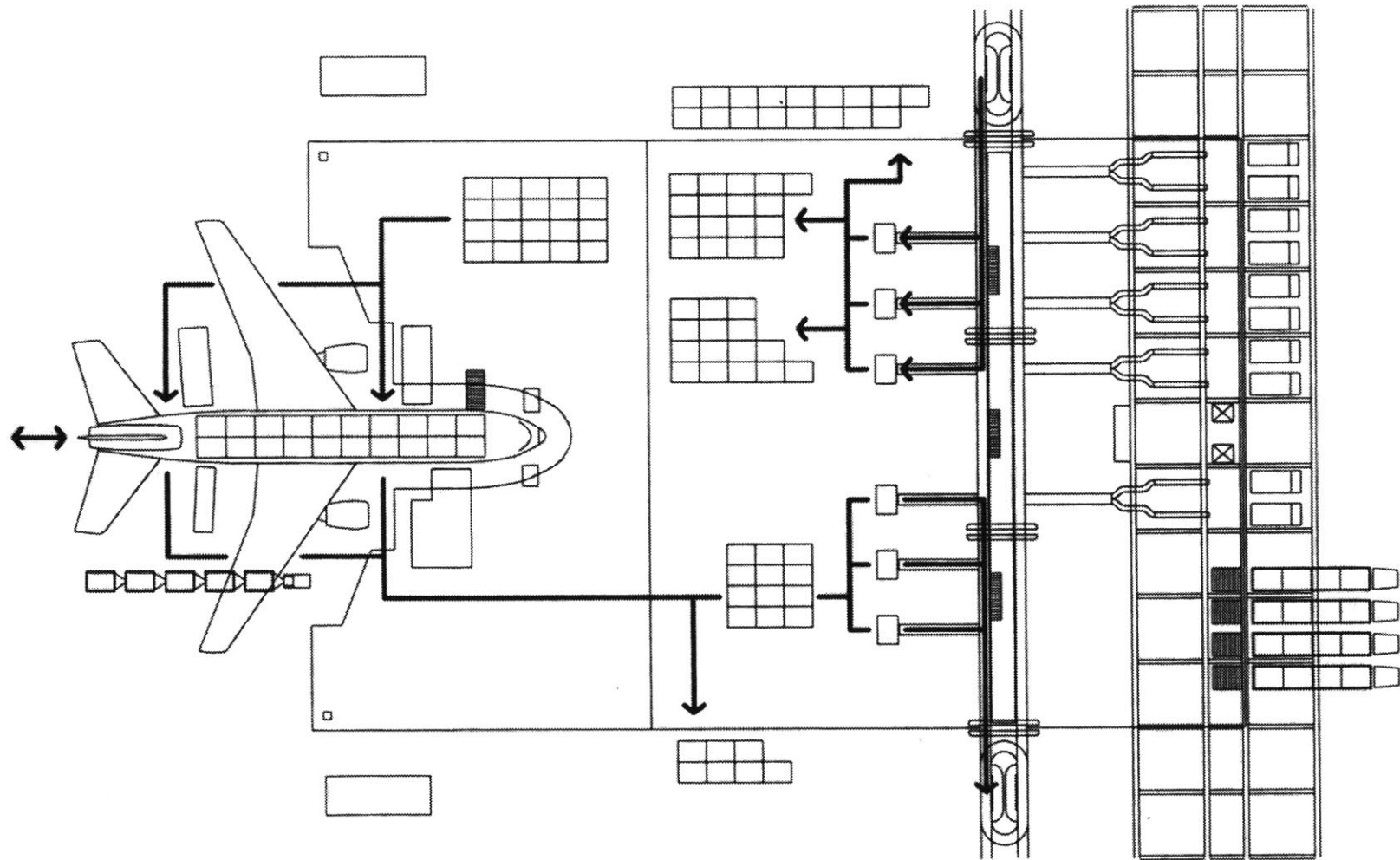
8:00 pm – 11:00 pm

The walk-in vans enter the facility where they each engage one of the sorting system's belt extensions. The contents of the walk-in vans are then unloaded onto these secondary belts, then distributed through the facility by the main belt system. The contents eventually travel to the ramp side of the facility into one of the large containers.



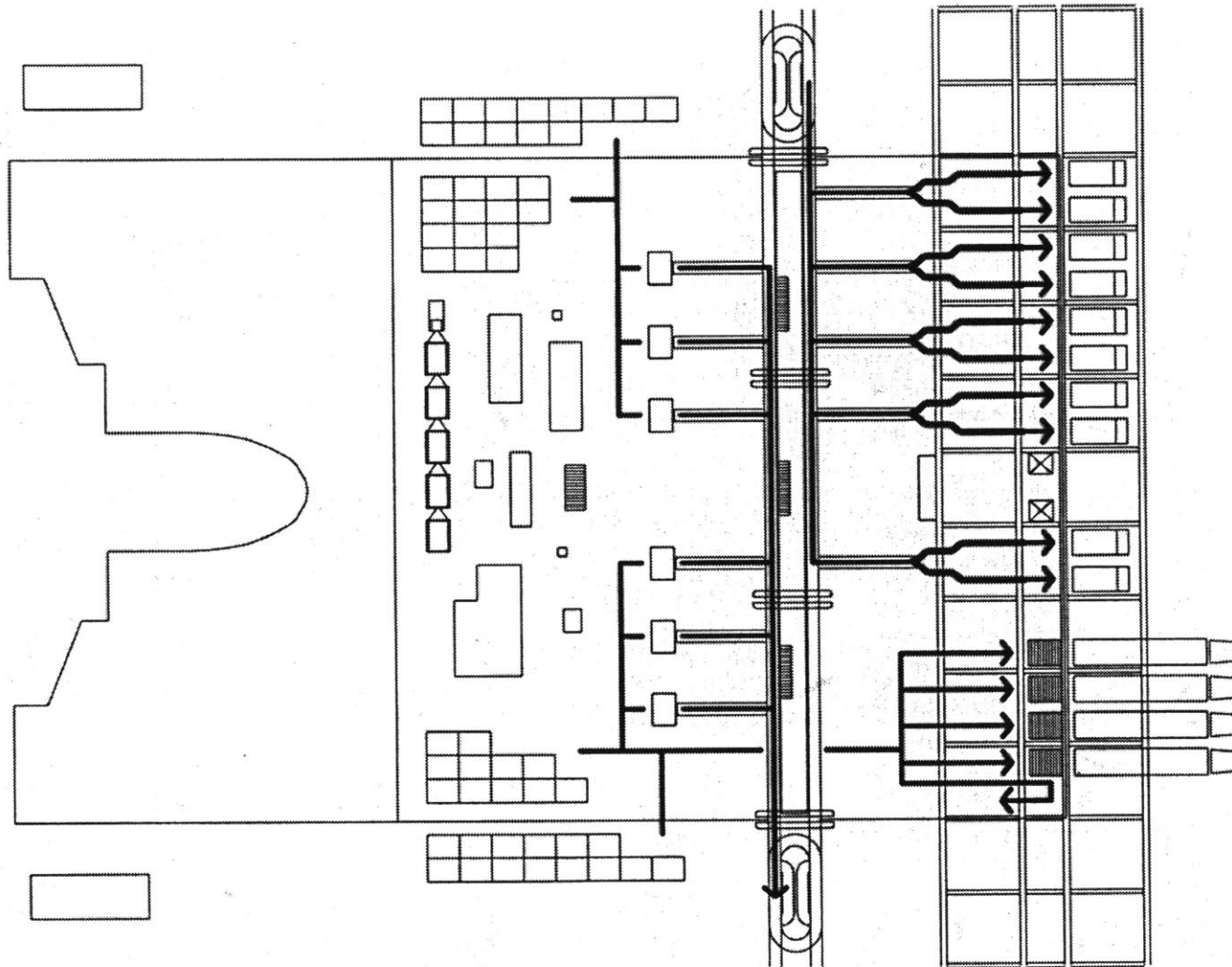
11:00 pm – 2:00 am

The airplanes arrive during this time frame and are unloaded in about 18 minutes. The unloaded containers are placed in a container staging area and the contents are placed onto the main sort system. The airplanes are loaded from the opposite container staging area and then depart to a strategic destination in the larger FedEx sort system.



2:00 am – 6:00 am

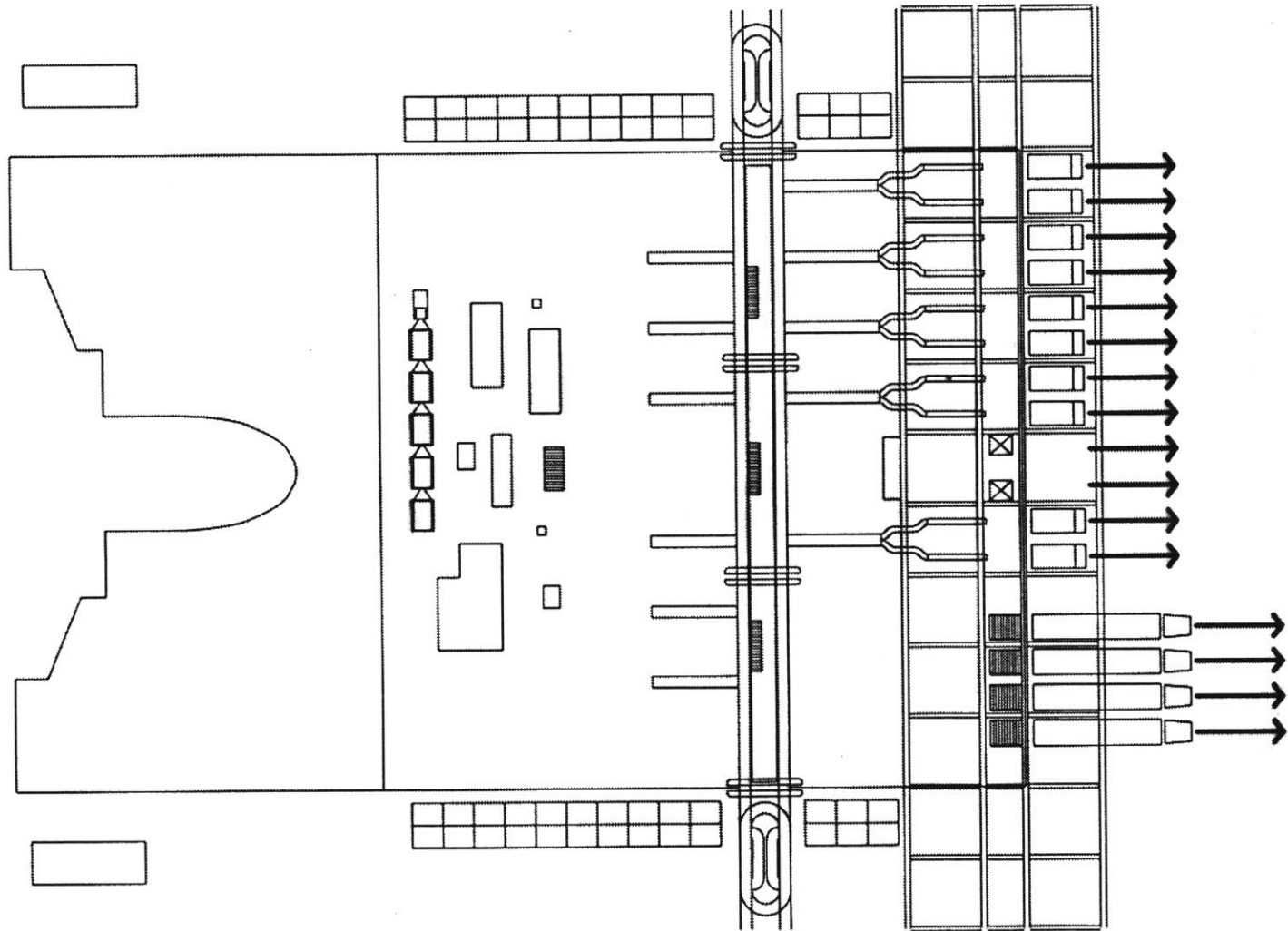
The contents of all the containers are distributed to the walk-in vans and CTVs via the sorting system's main belt and secondary extensions. The trucks are loaded during the next several hours and begin preparations for departure.



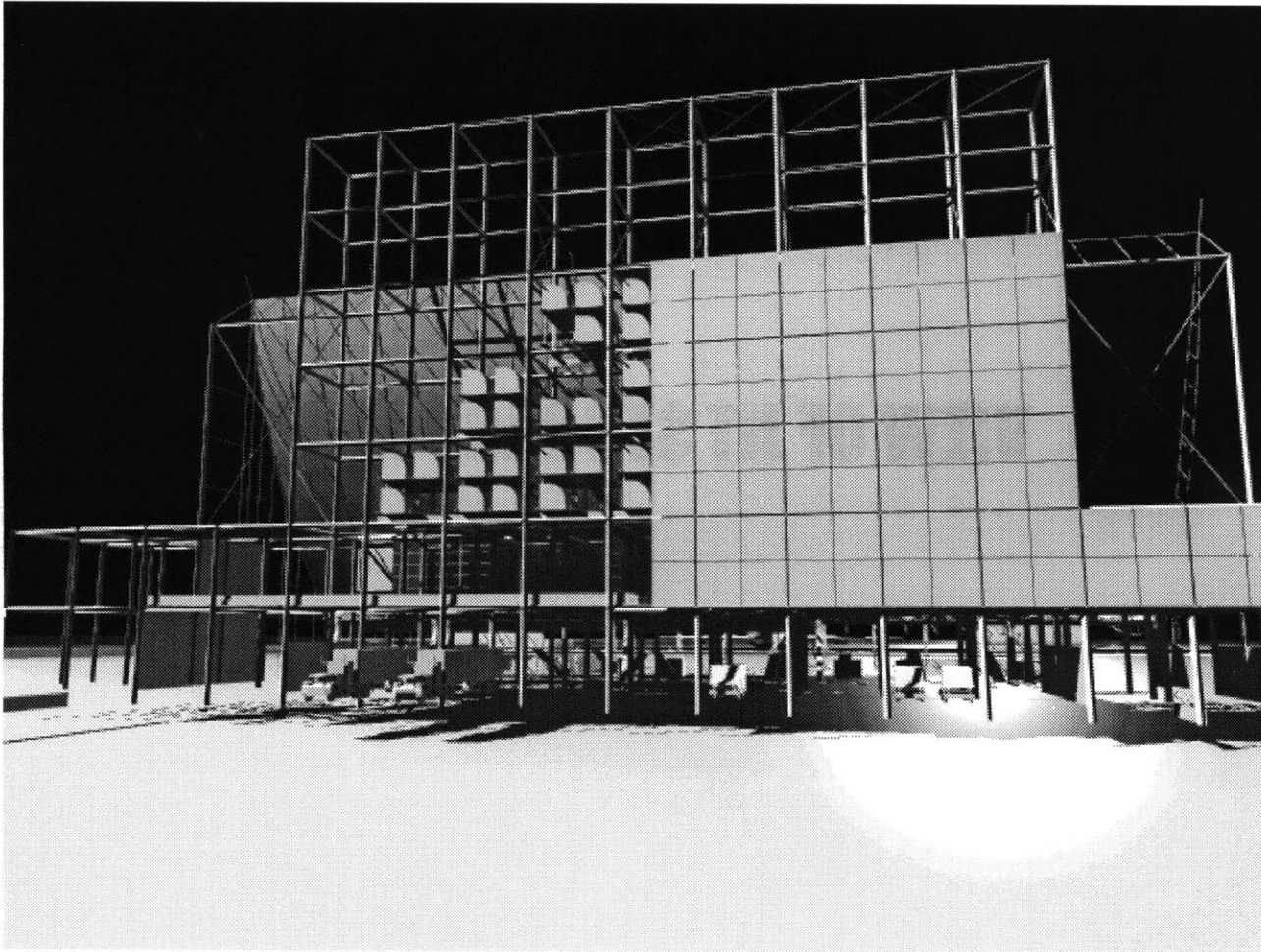
6:00 am – 7:00 am

The sorting process is over. All vans and trucks are loaded and begin their journey into the neighborhoods and business districts for delivery of each package by 10:30am.

The facility will be essentially down until 6:00pm, at which time the entire process will begin again.



**VIEW OF TRUCK DOCKS
AND JIT STORAGE WALL**



VIEW OF JIT STORAGE WALL



CONCLUSION

Building *performance* is such an enormously important topic in architecture, but one rarely explored. Perhaps it is because performance is so difficult to predict, to measure, to quantify, etc. But that shouldn't hinder the architectural research that is necessary to provide the basis for academic study and professional application. The study is very much a worthwhile endeavor.

This thesis has attempted to bridge a gap between the qualitative approach to solutions of architecture and the quantitative solutions of the more business-minded. It has attempted to examine a real world project in a real world manner, albeit without regard to some paramount constructability and financial questions. In that sense, the thesis has hinged on architectural speculation alone.

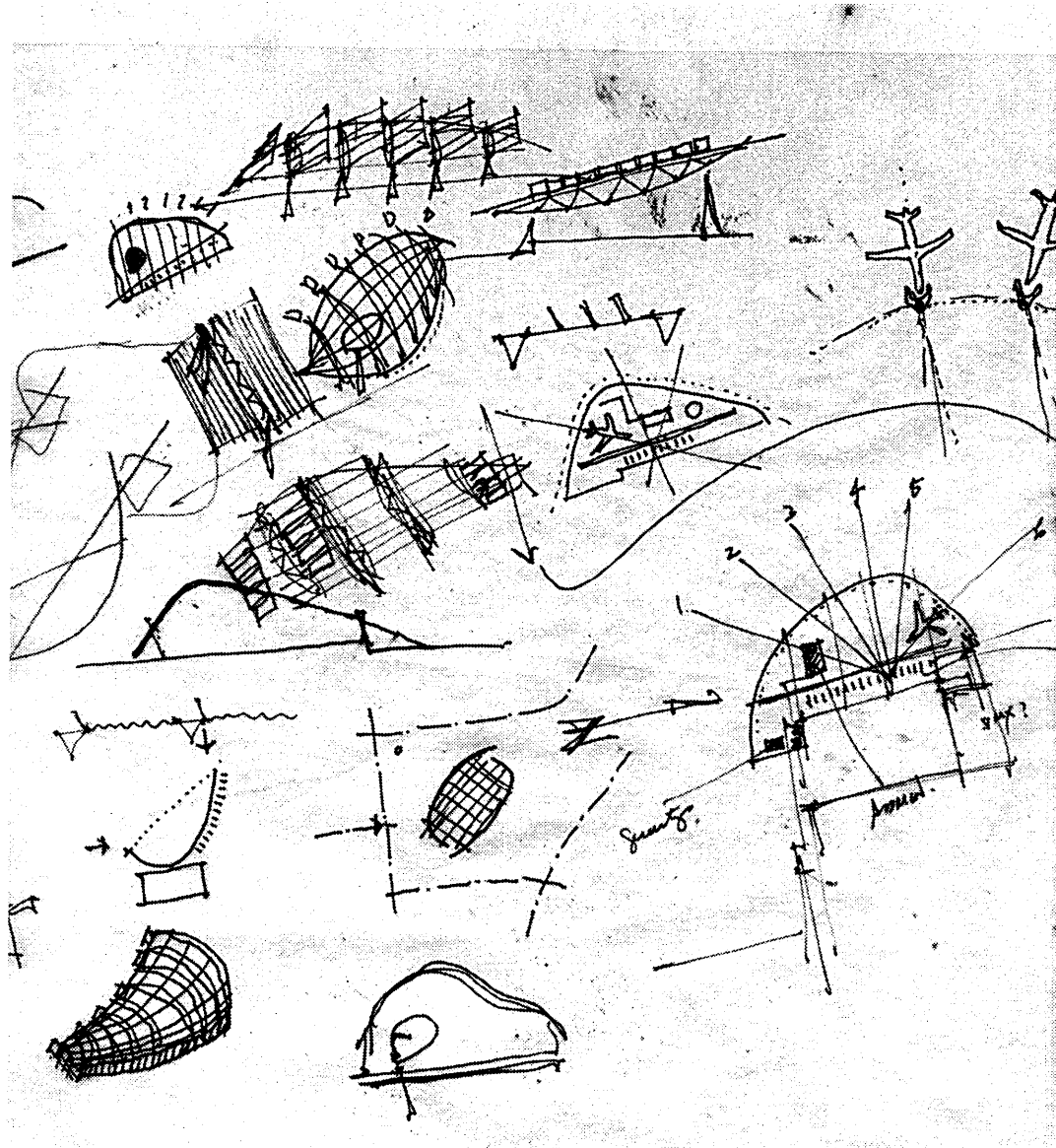
But architectural thinking can provide valuable information during a complicated design process like this one. It offers an alternative way of approaching a problem and can give new insight into a potential solution. The weakness is trying to survive simply on the architectural *proof*, which for some reason commonly disassociates itself from the reality of building. I believe this thesis, as well as many others, would be more valuable if, from the beginning, were teamed with another department or professional entity. After all, it's more than *architectural form* that's necessary to create change.

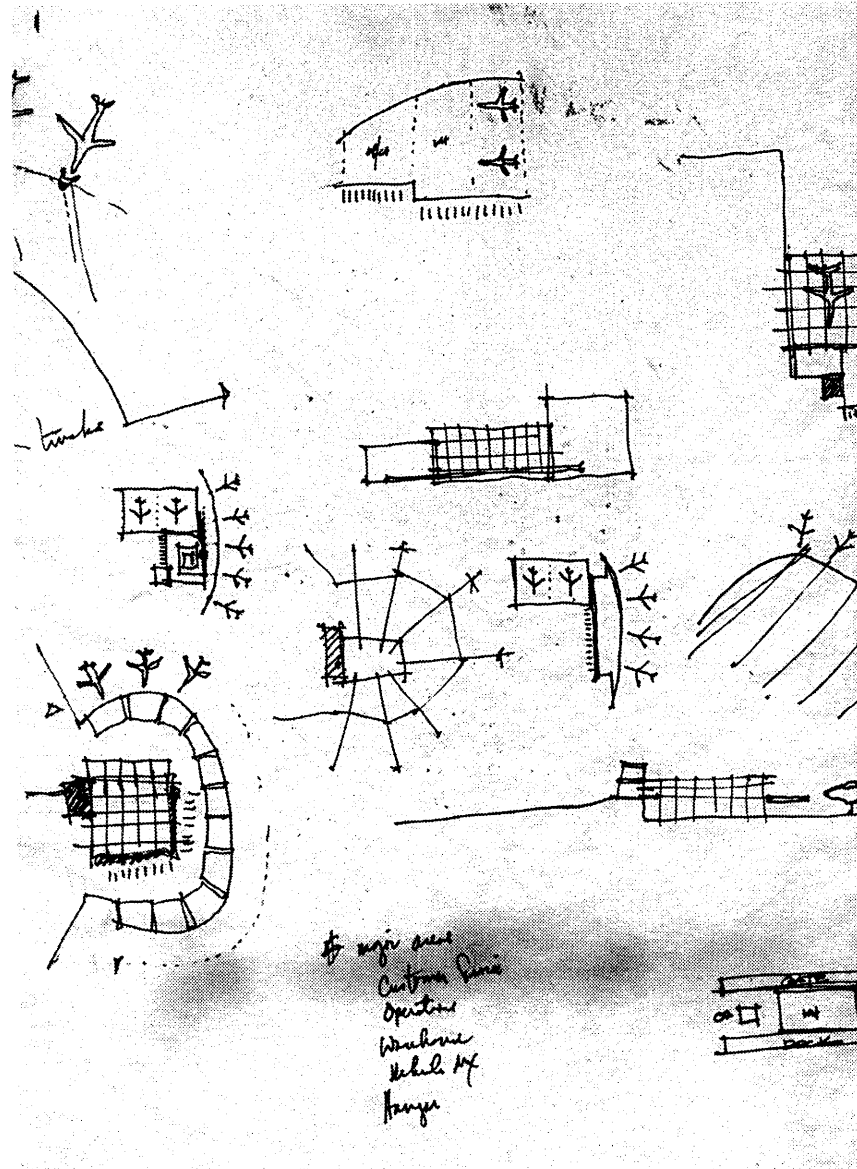
I do not want to suggest that the thesis has not been both challenging and even successful. I believe it has. My point is that the architectural community has the opportunity through these kinds of studies to make an enormous impact on the building decisions of large corporations like FedEx. But the research must include additional data beyond the sophisticated architectural speculation. Corporations, developers, and the like need to be met at least halfway. If architects don't do that, someone else will ... look around ... other professions already have.

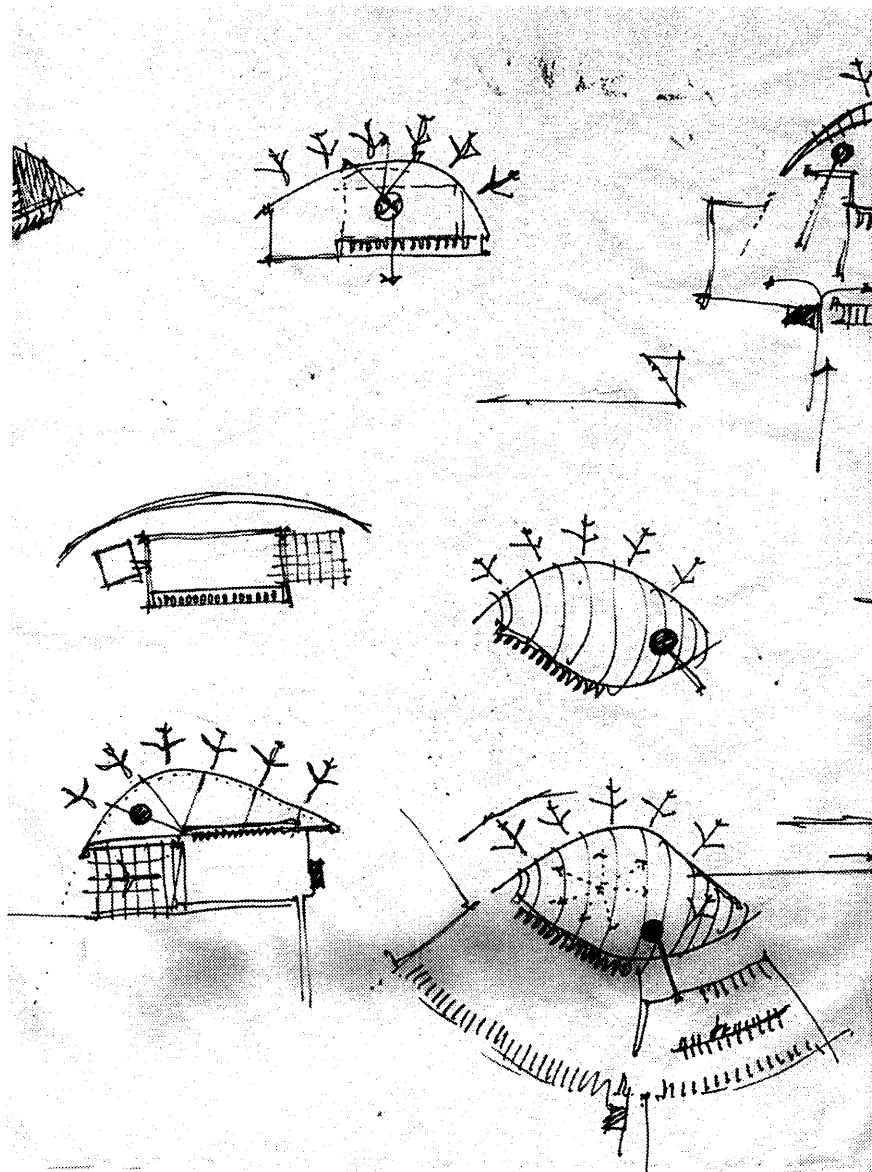
SKETCHES

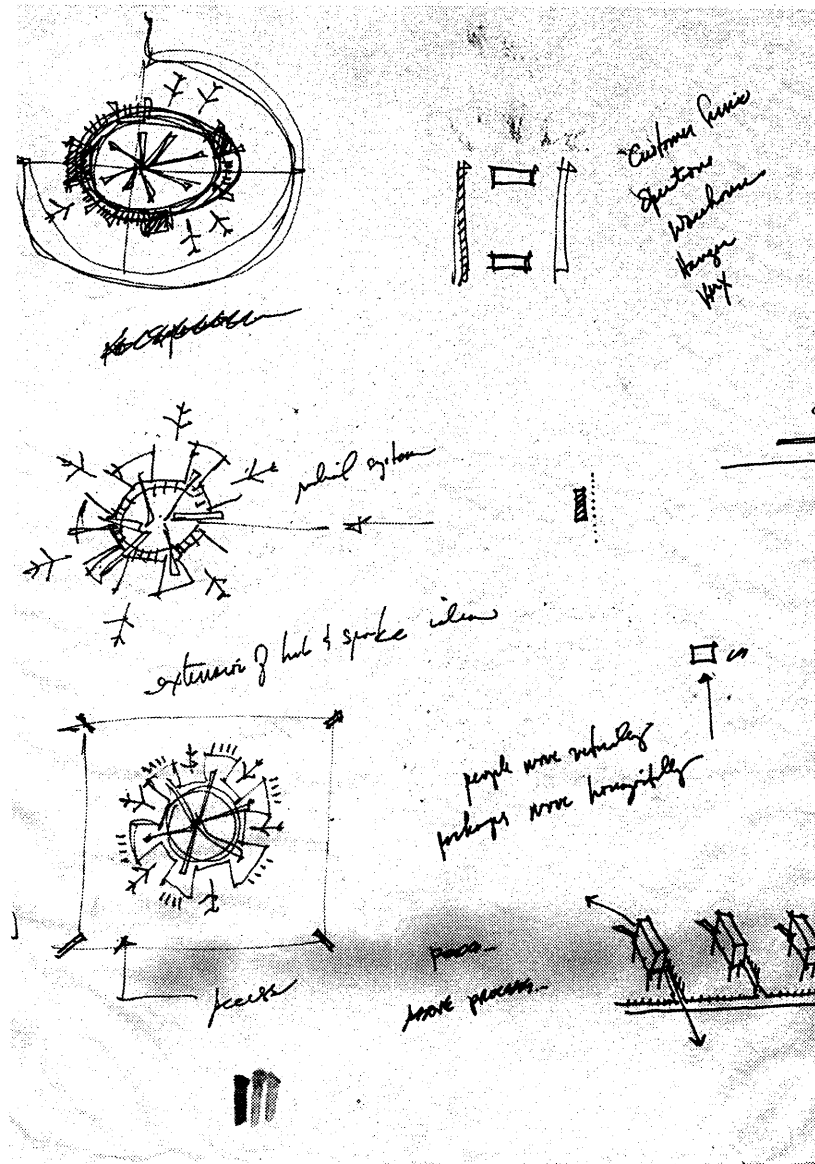
These sketches are presented as a chronological record of my thesis design exploration and to make public the method by which I have arrived at many of my architectural designs during my time here at MIT.

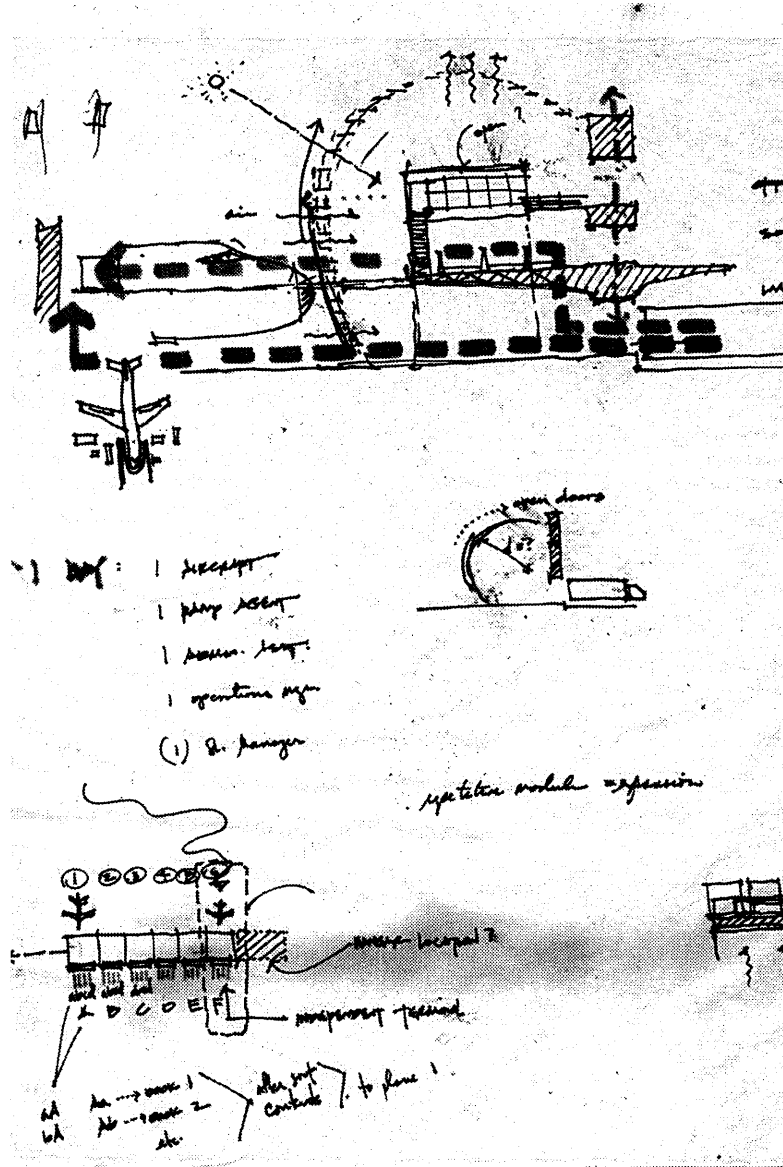
Many, if not all of these sketches were drawn on the small leftover desk space I have directly in front of my computer at home. While the proximity to the computer wasn't always a factor, much of my work quickly evolved to the computer, was transferred from sketch form into the digital drawing format of AutoCAD, and eventually, rendered in 3DStudio.

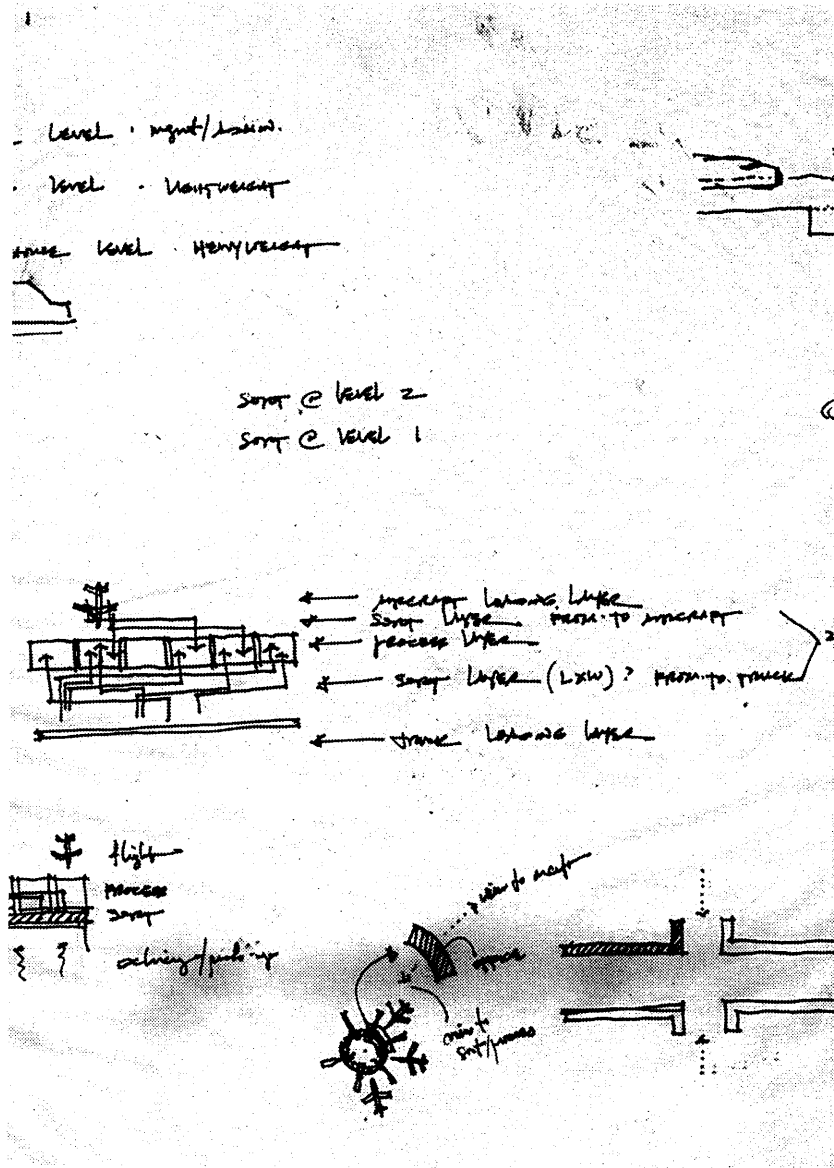


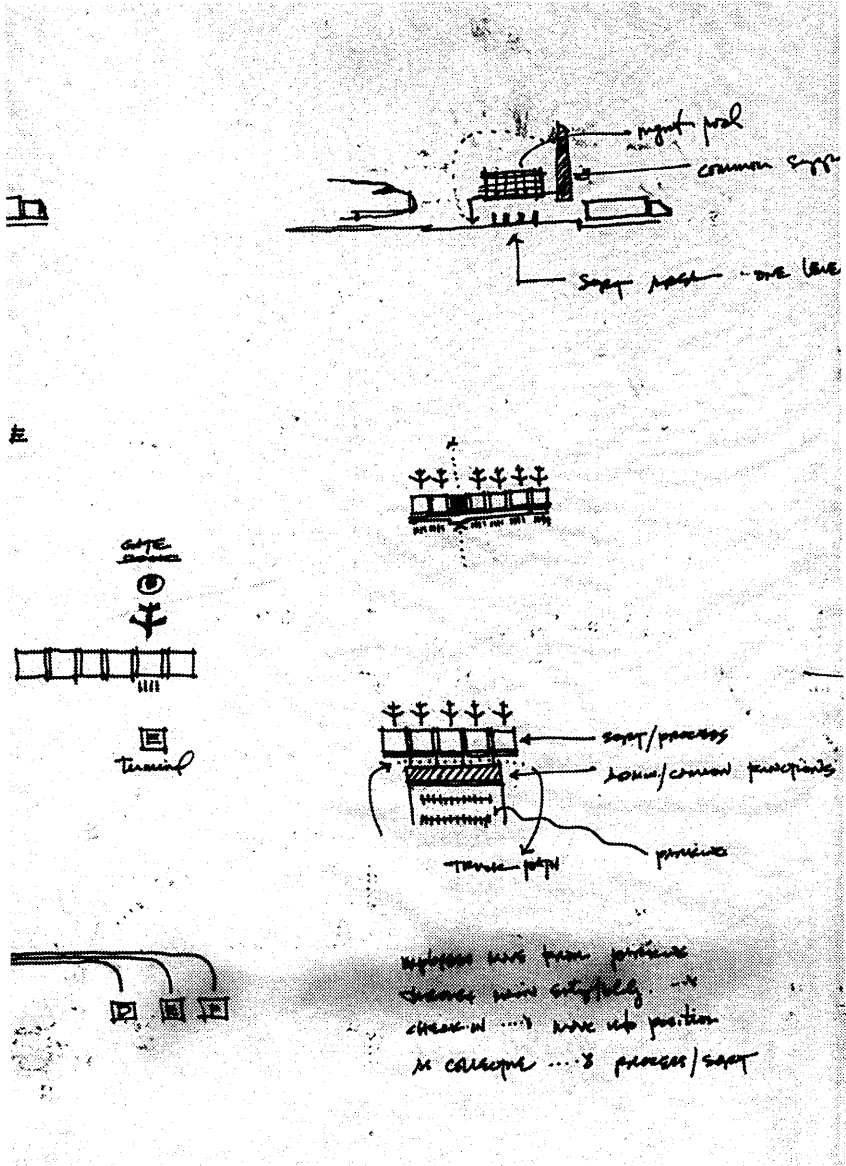


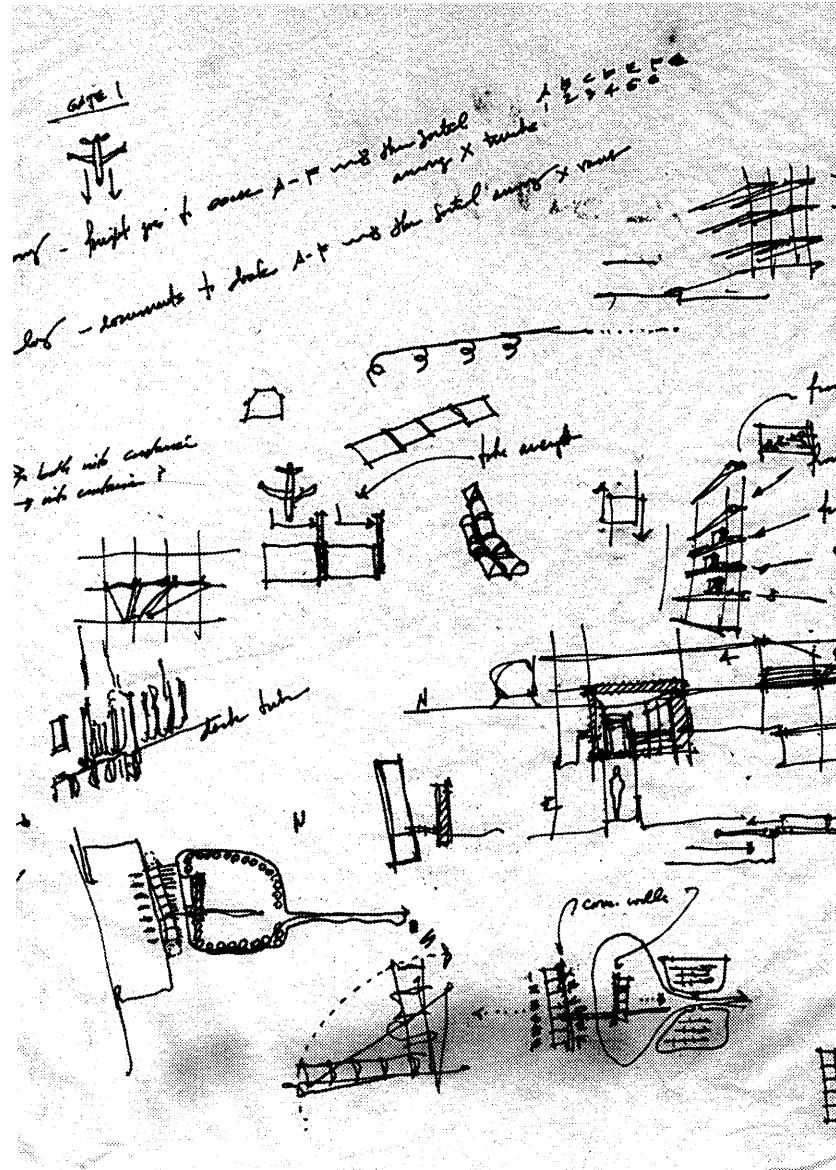


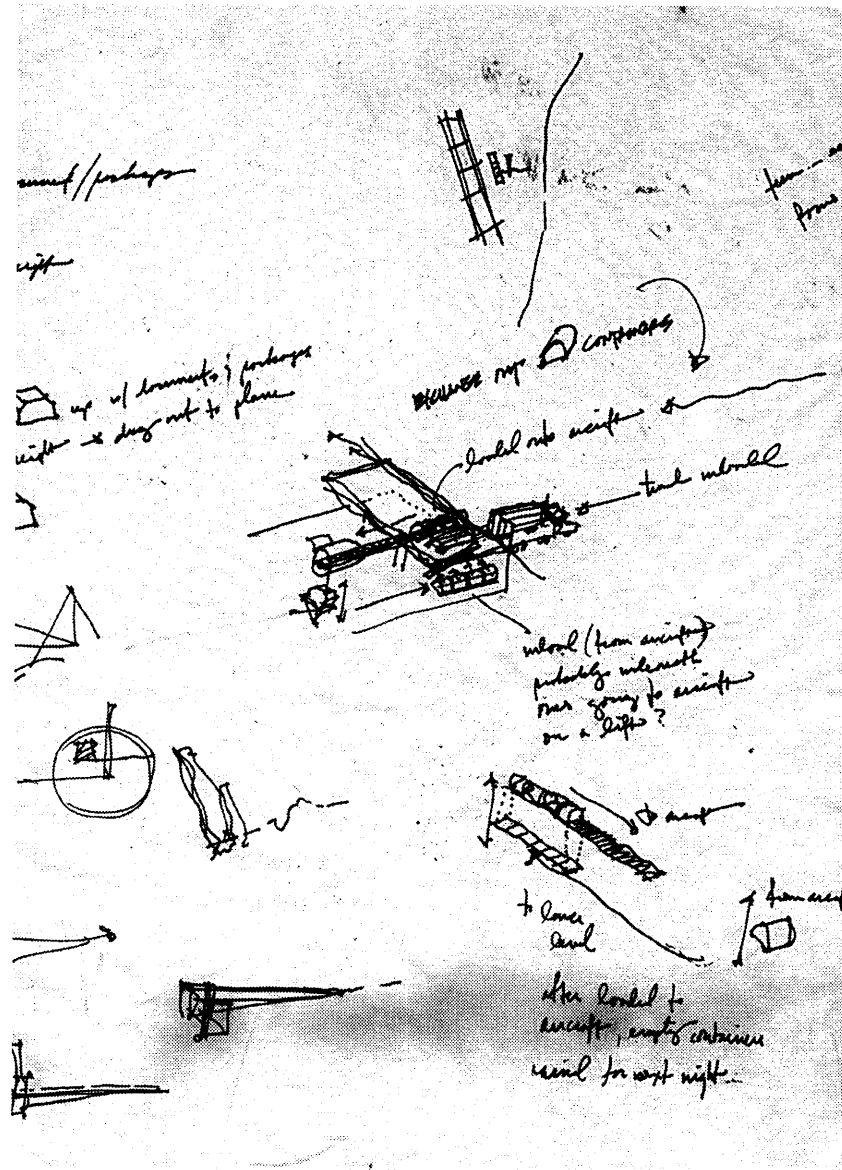


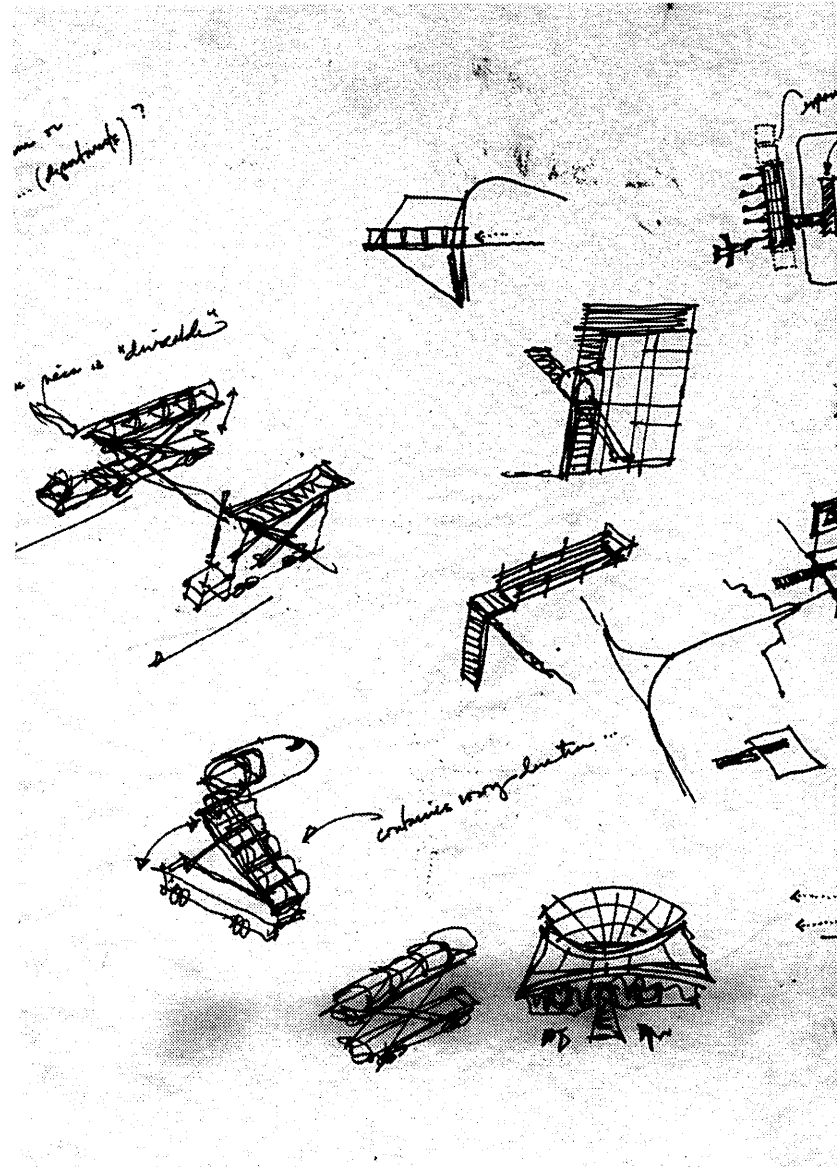


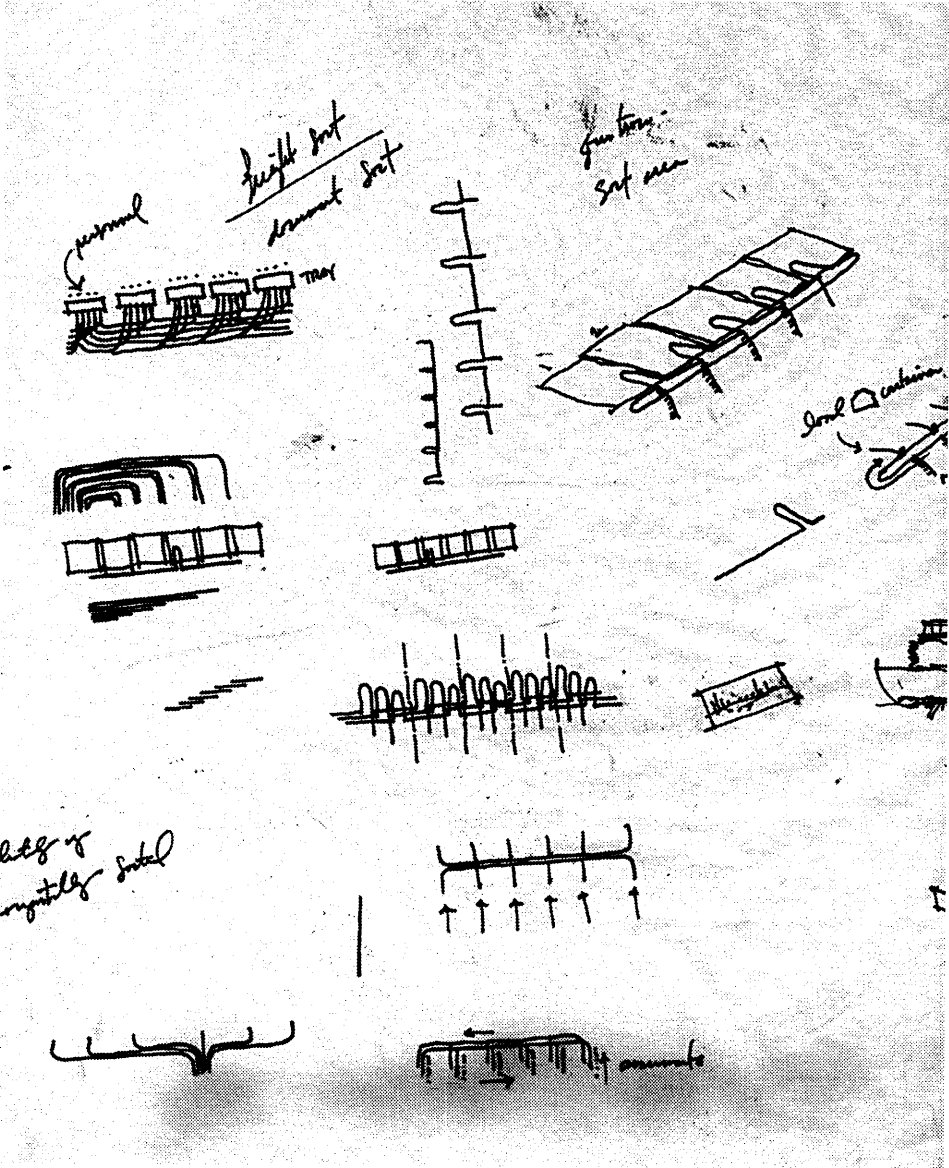


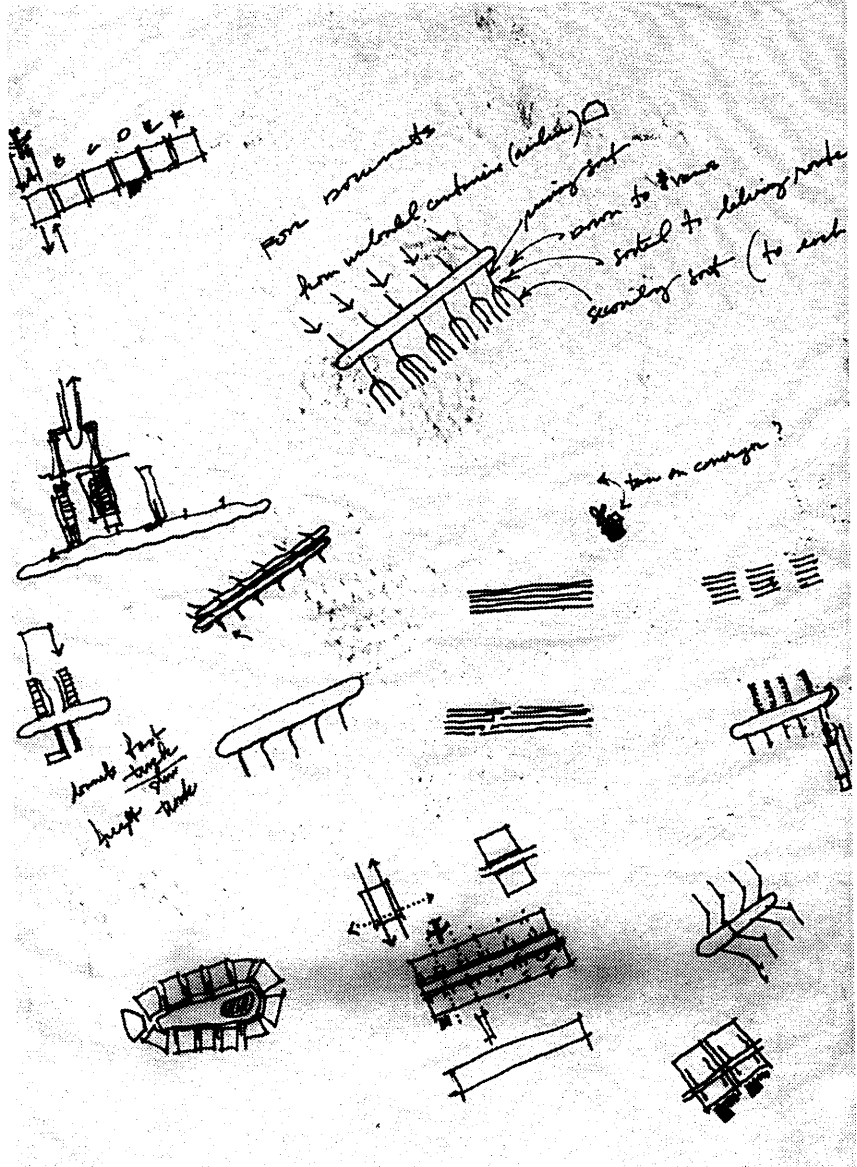


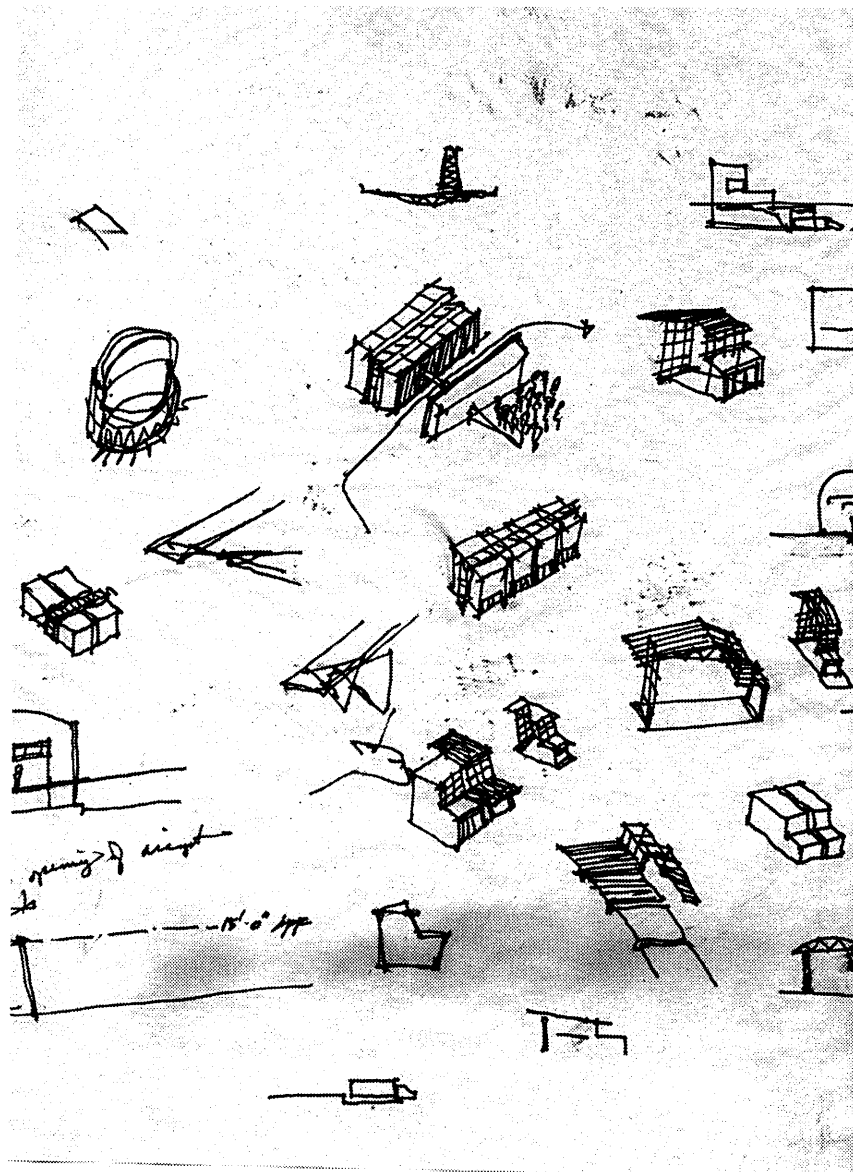


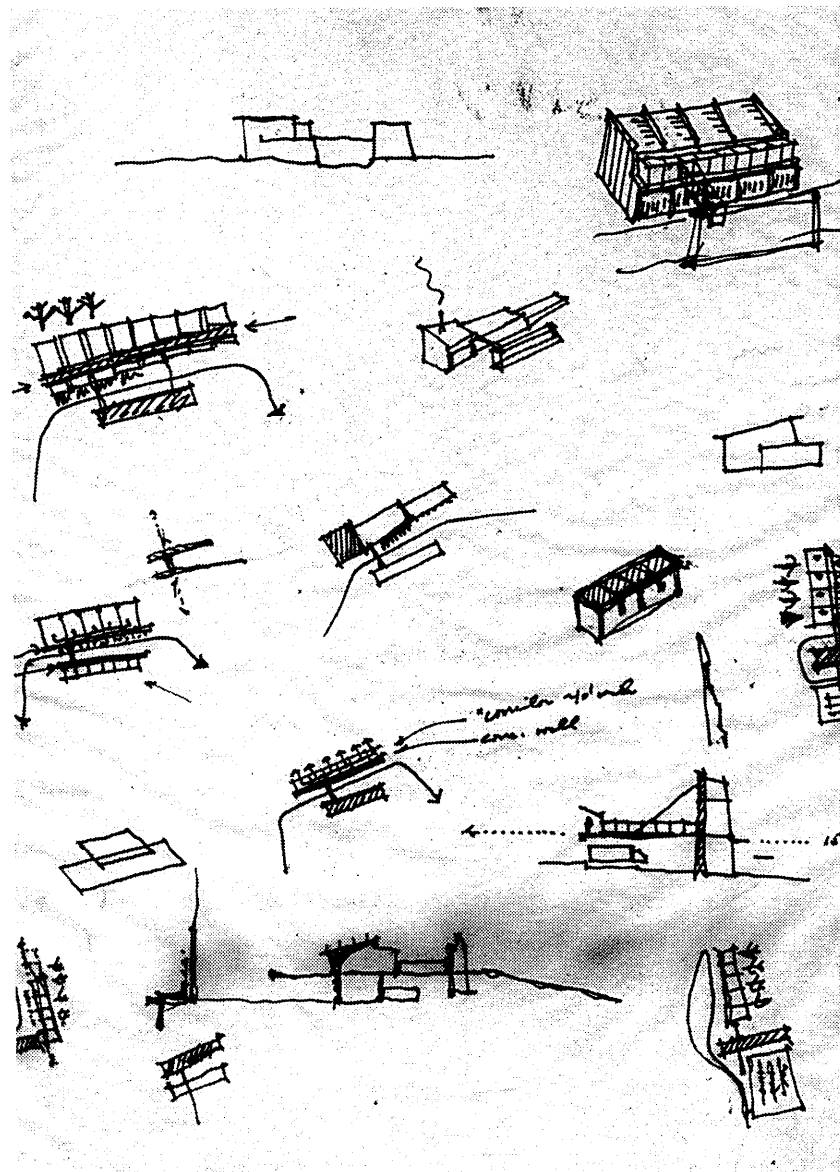


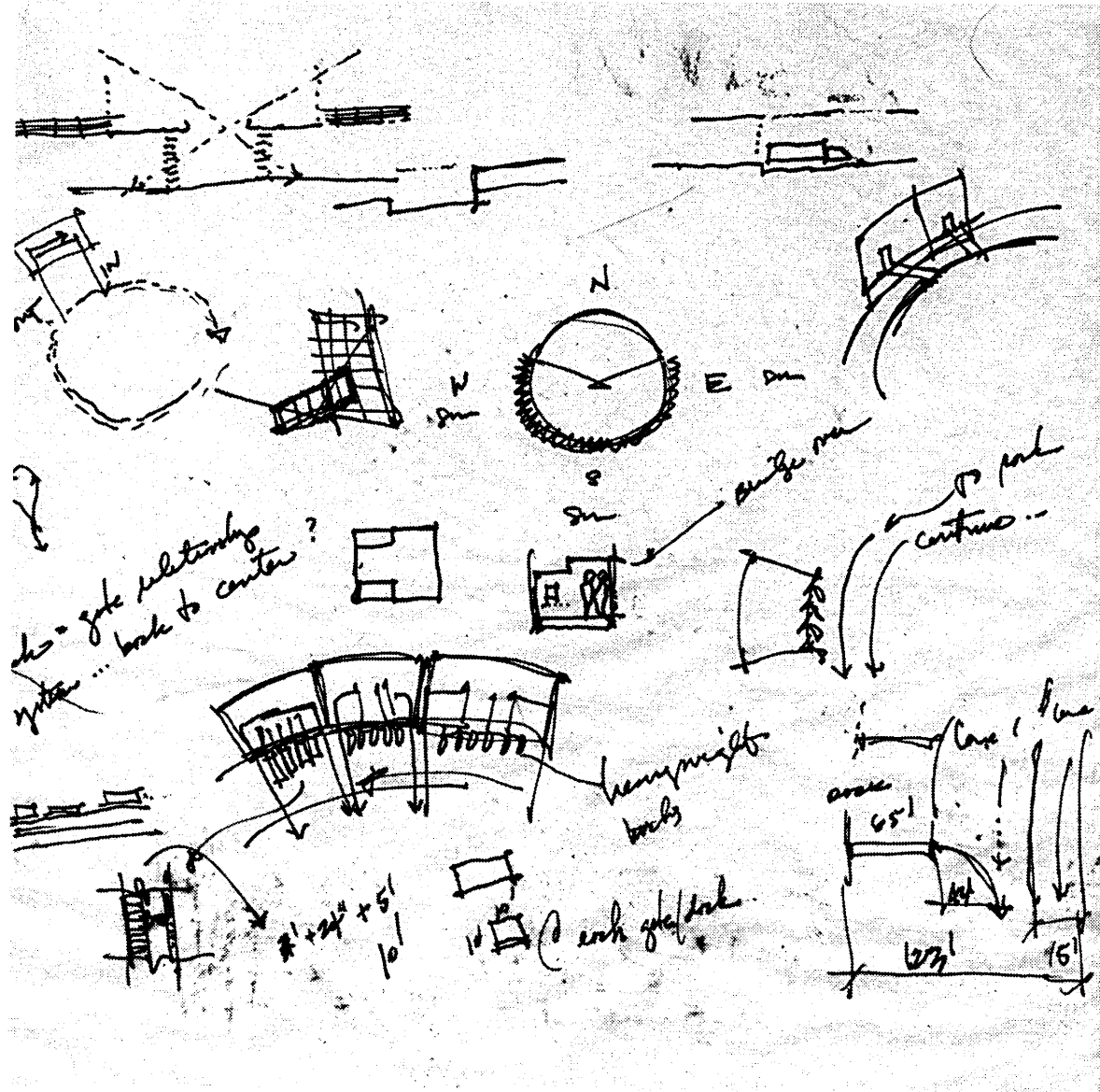


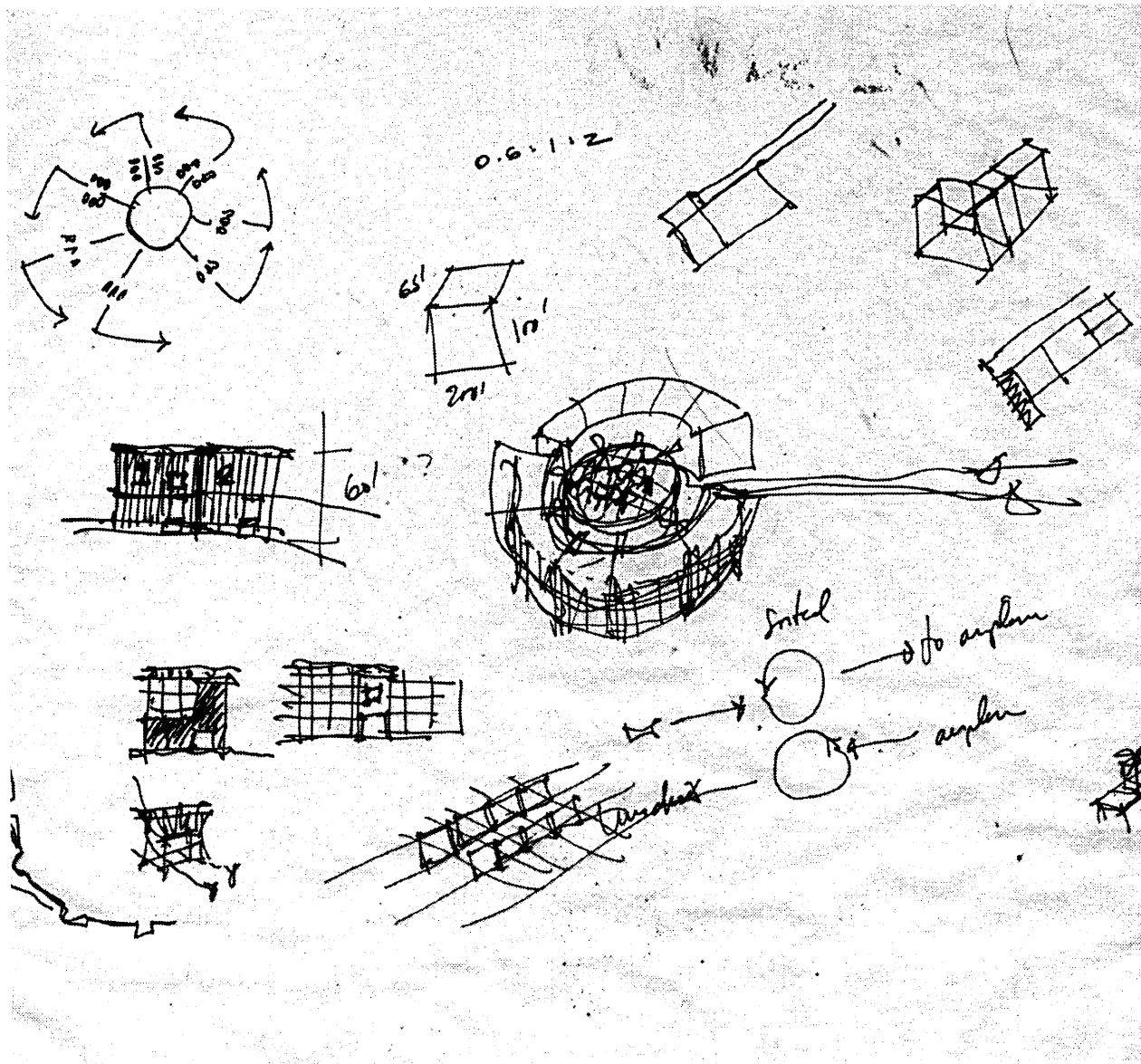


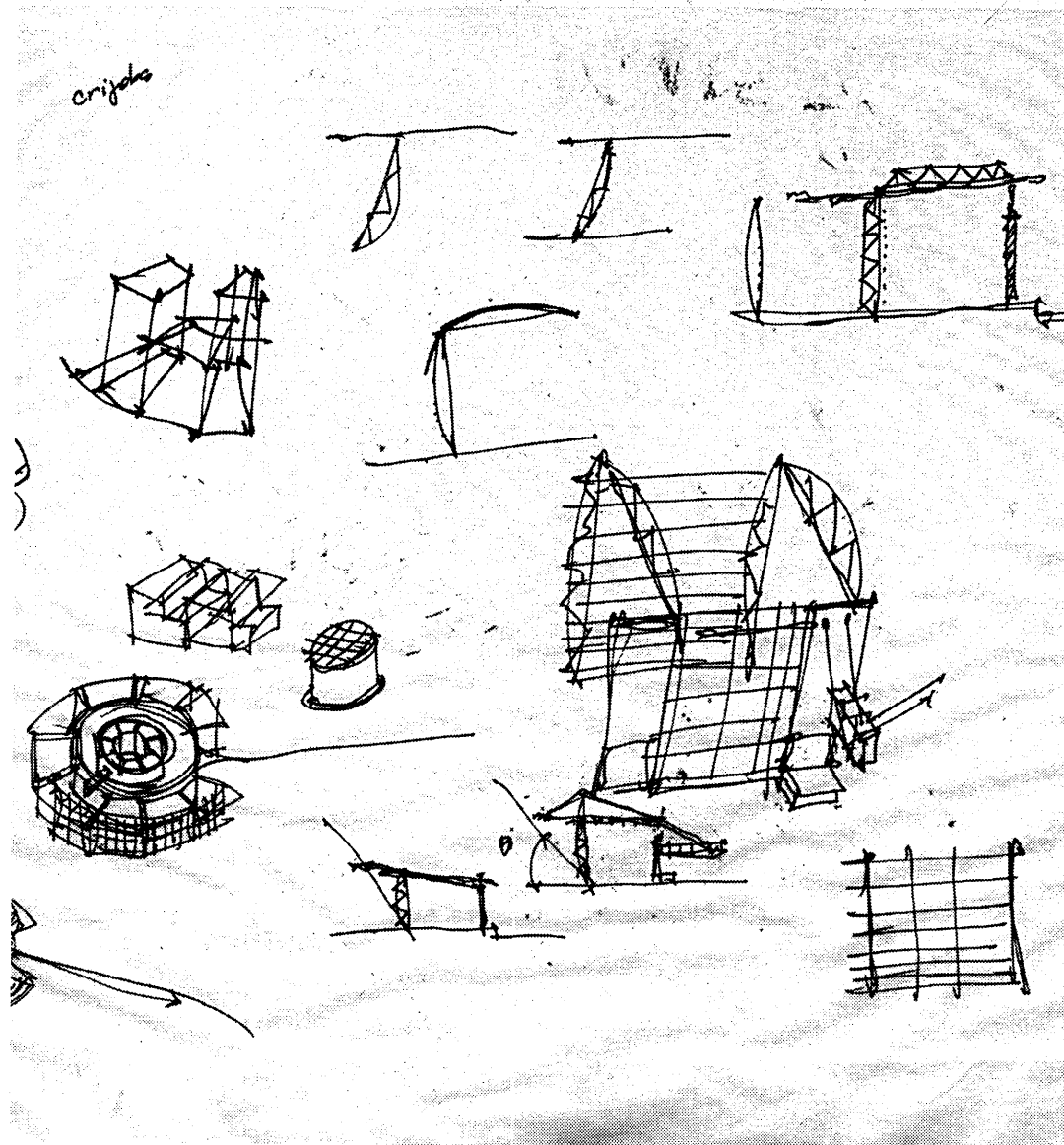


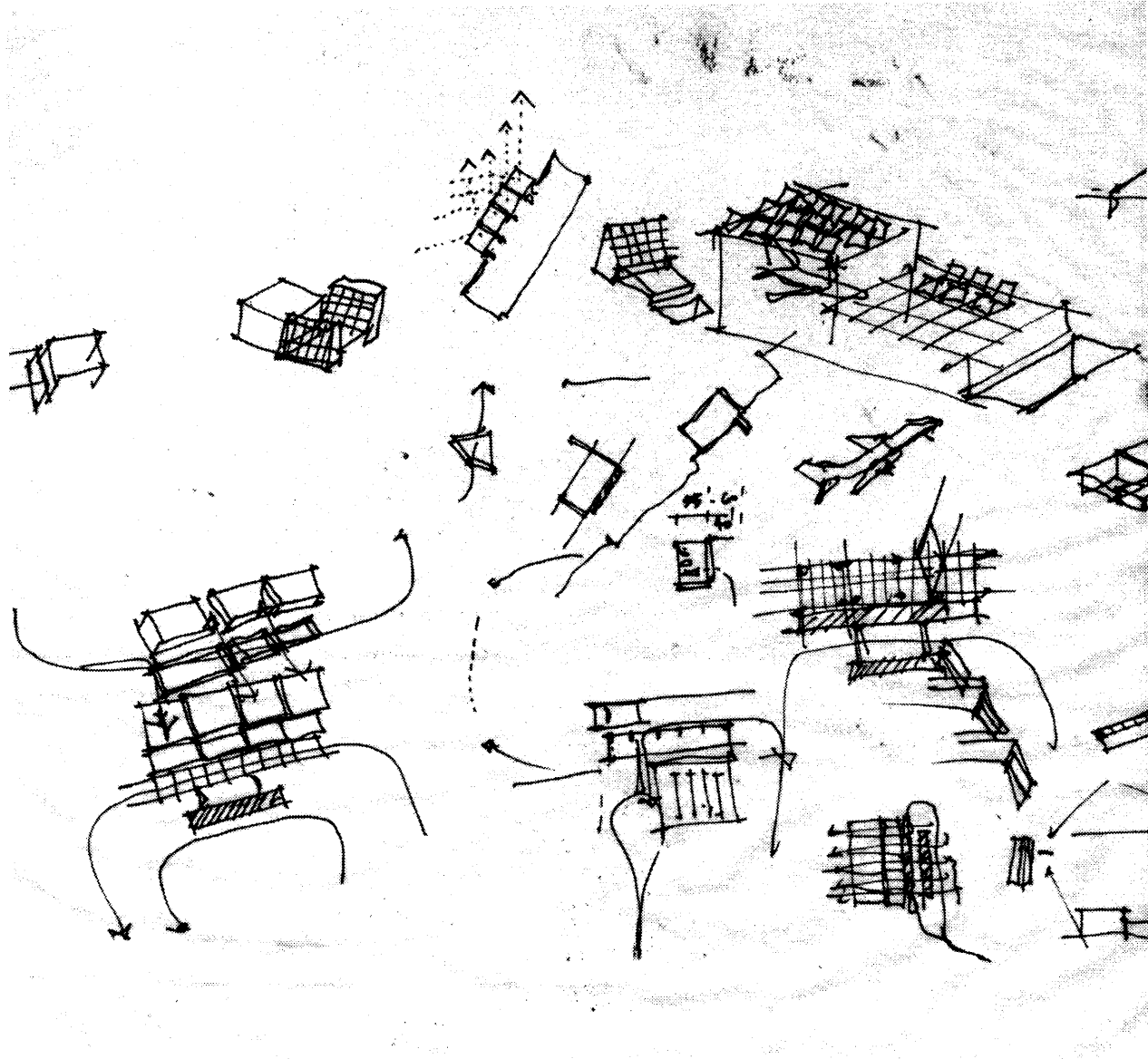


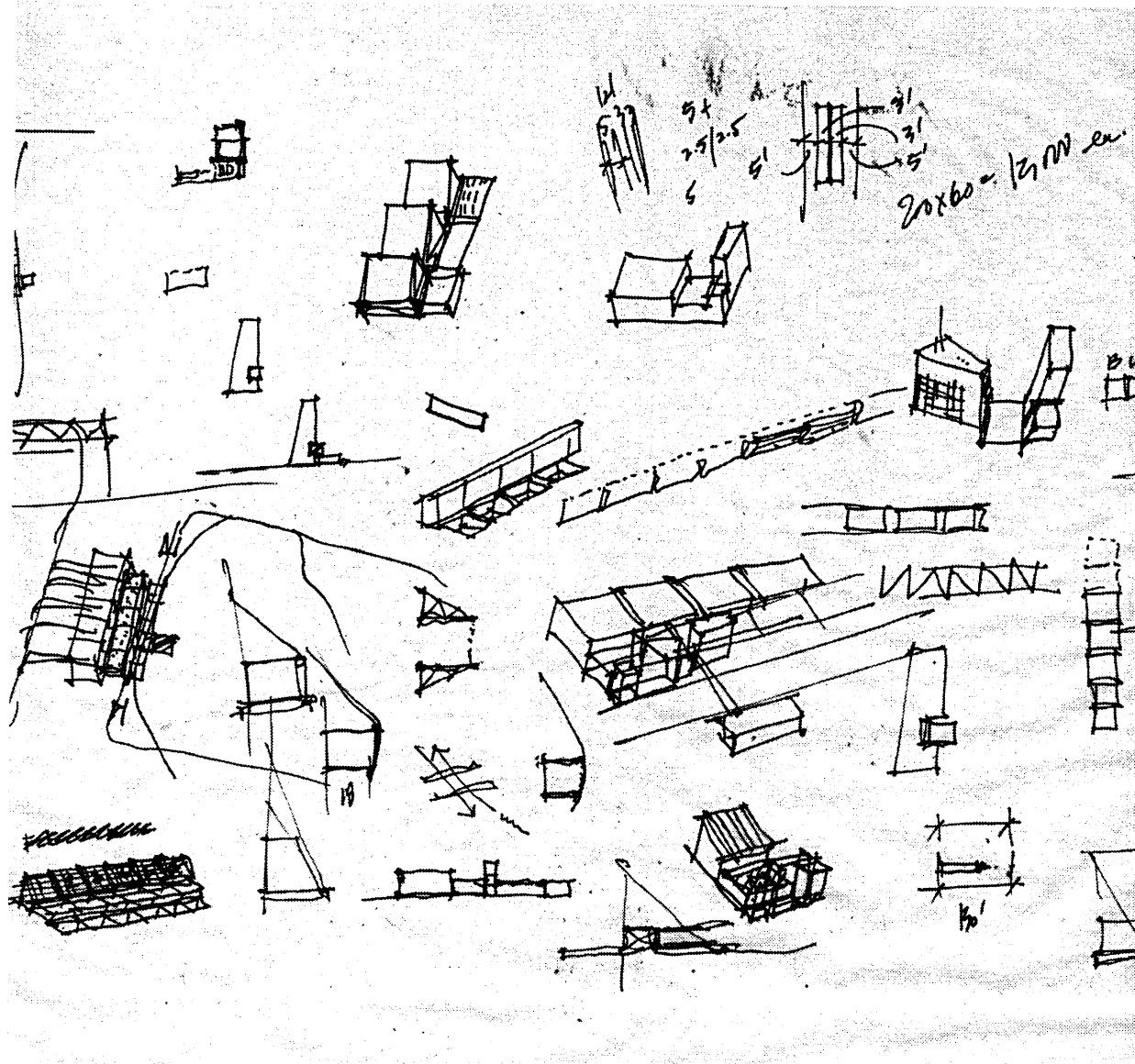


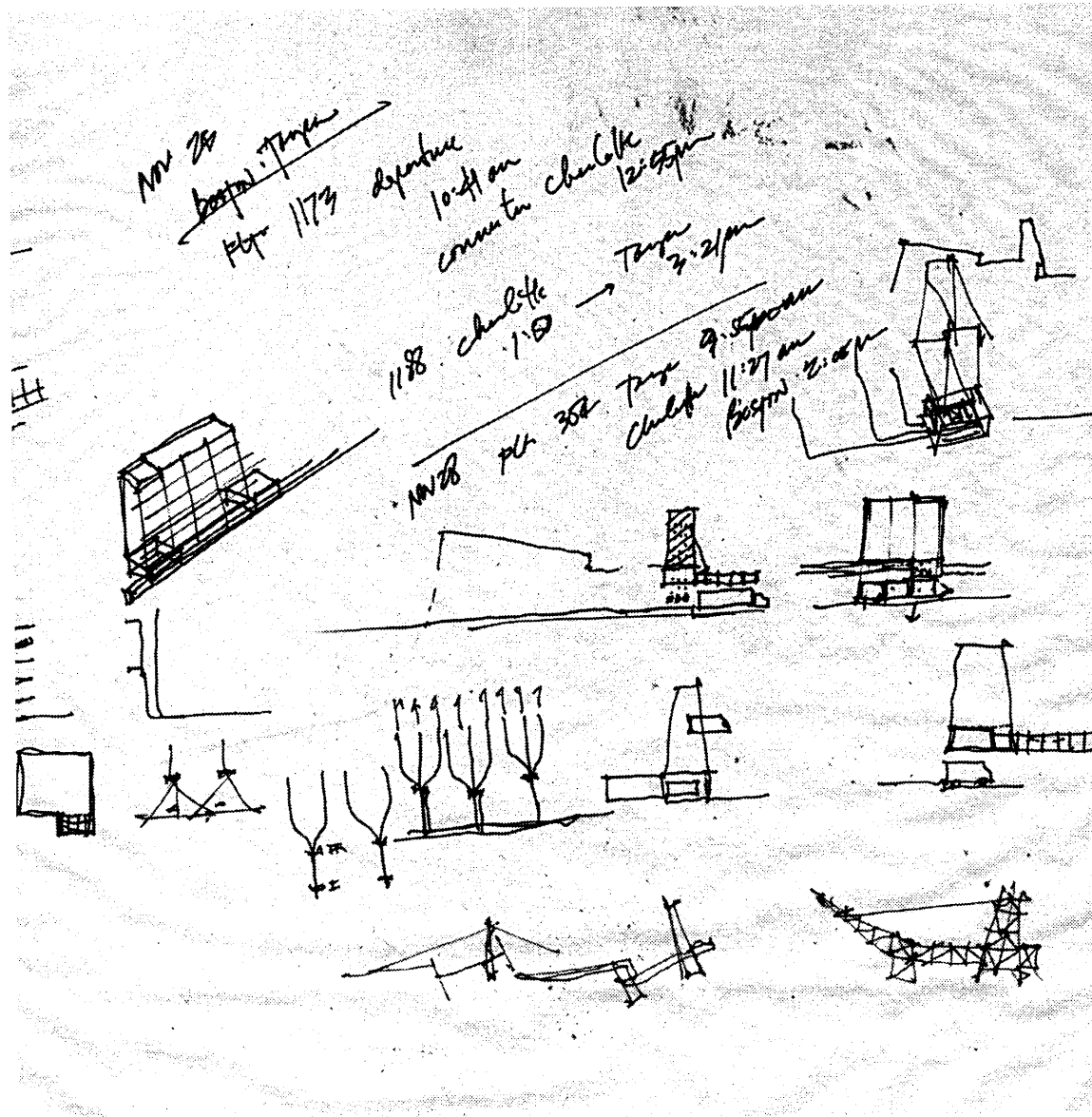


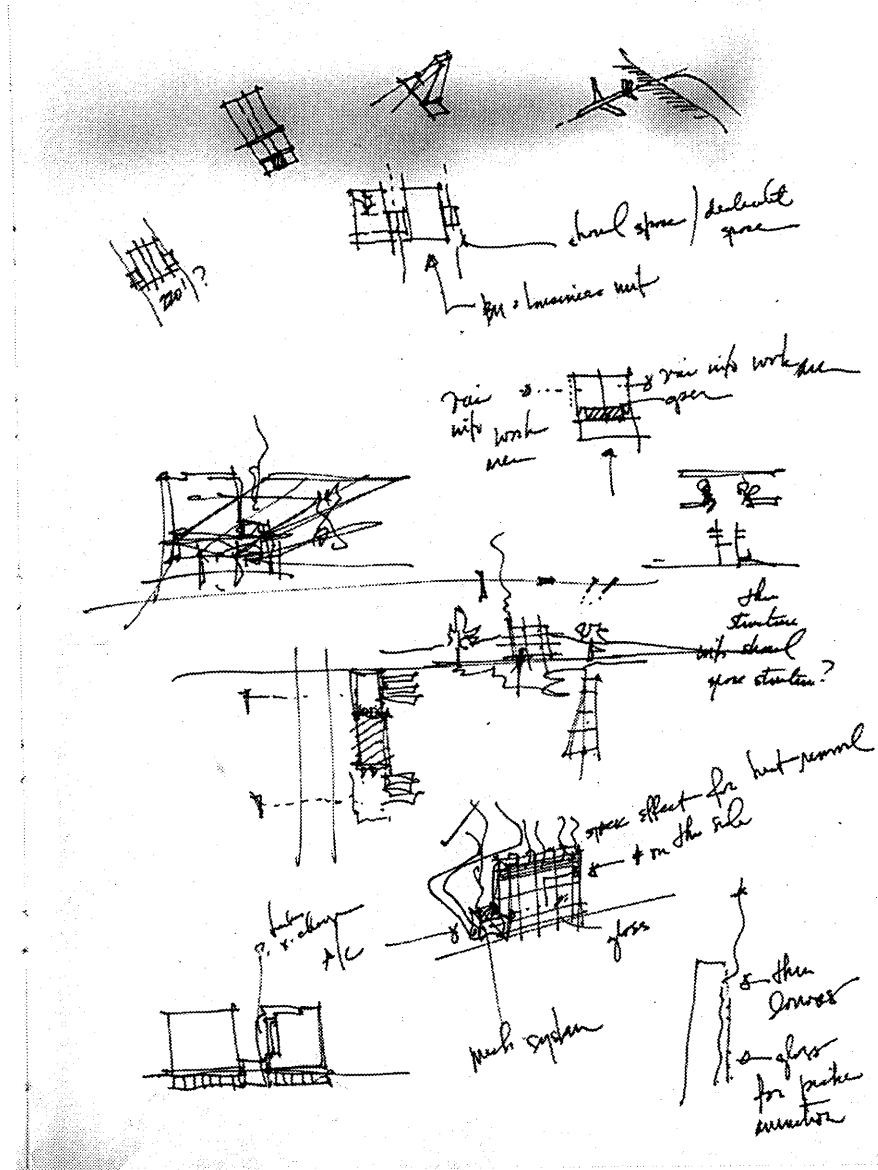


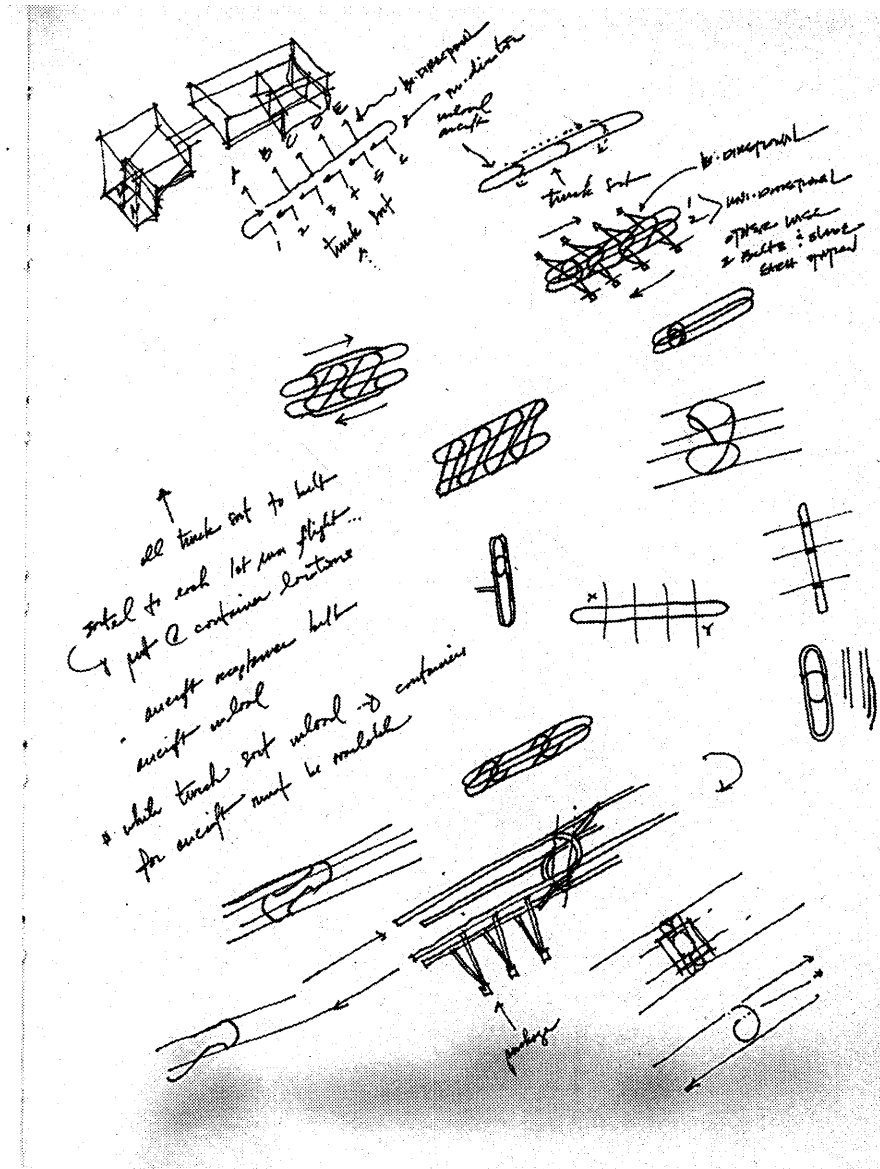


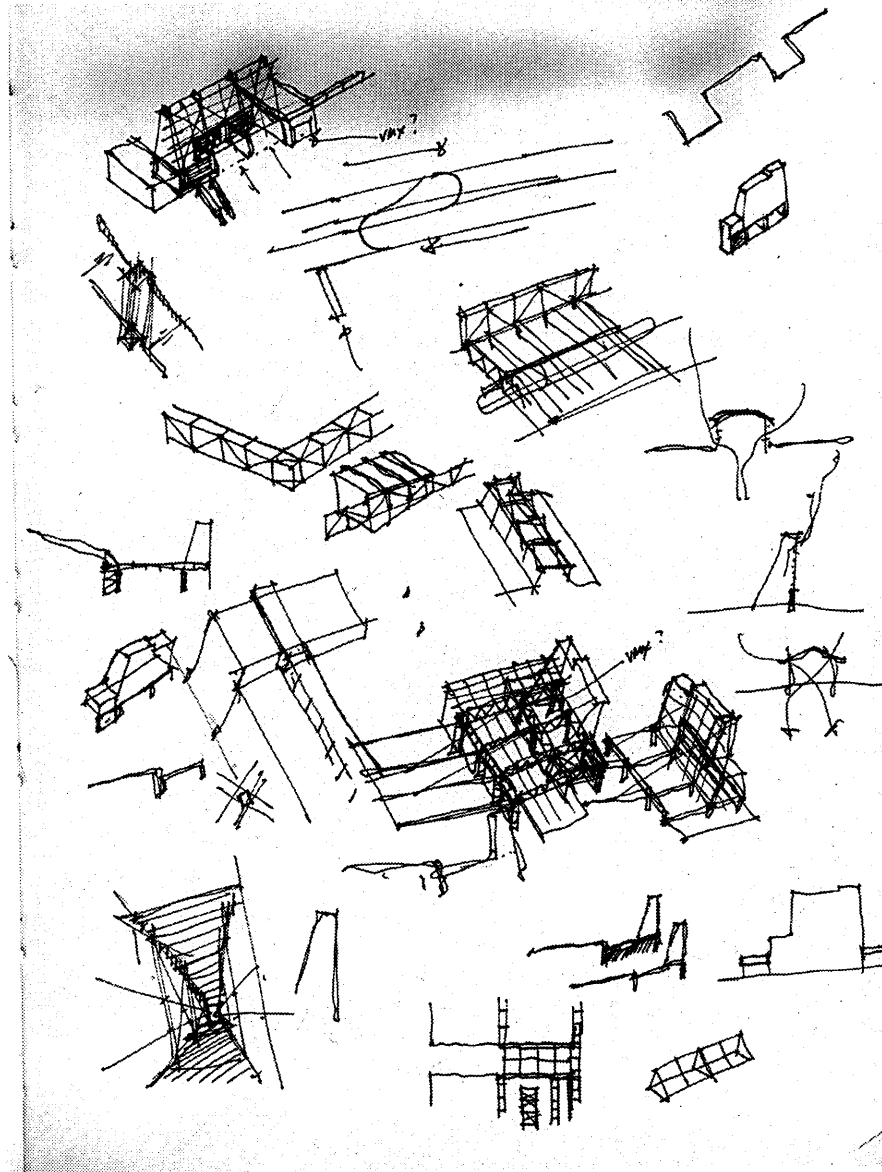


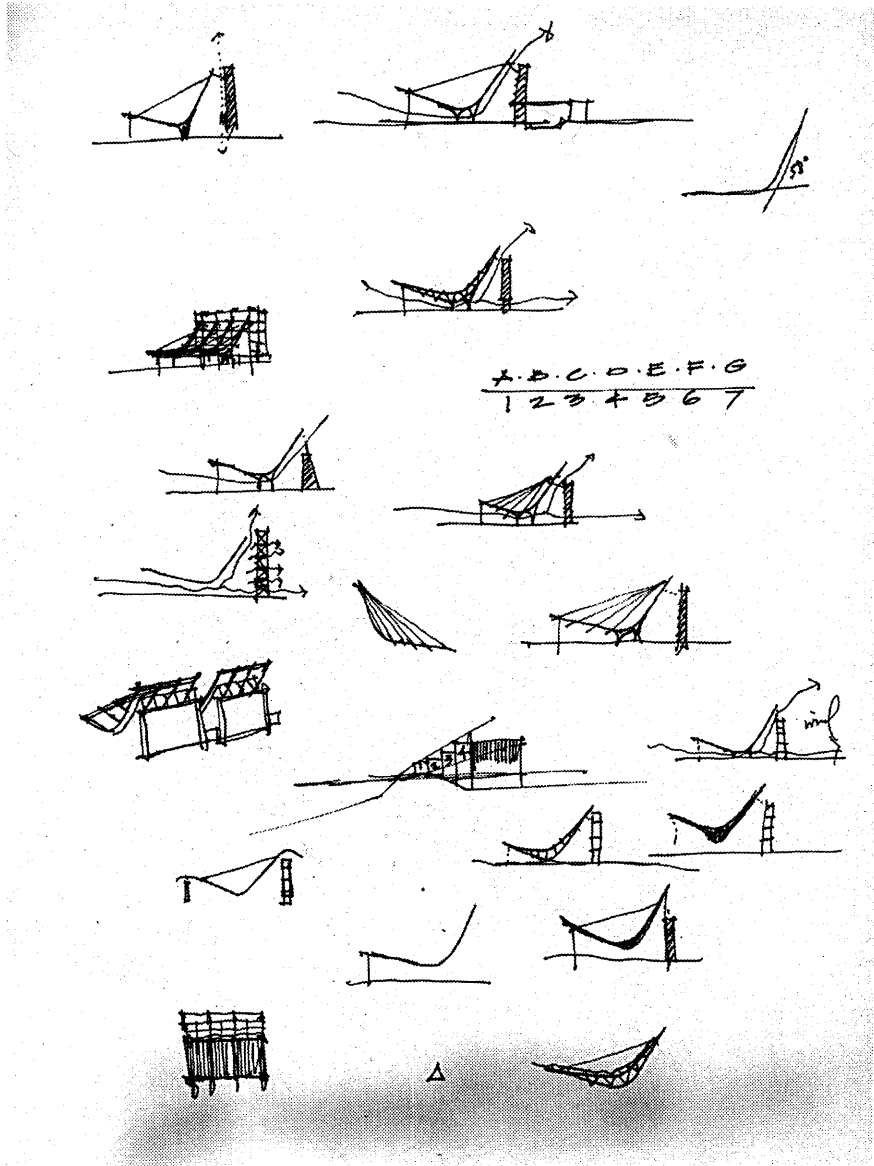


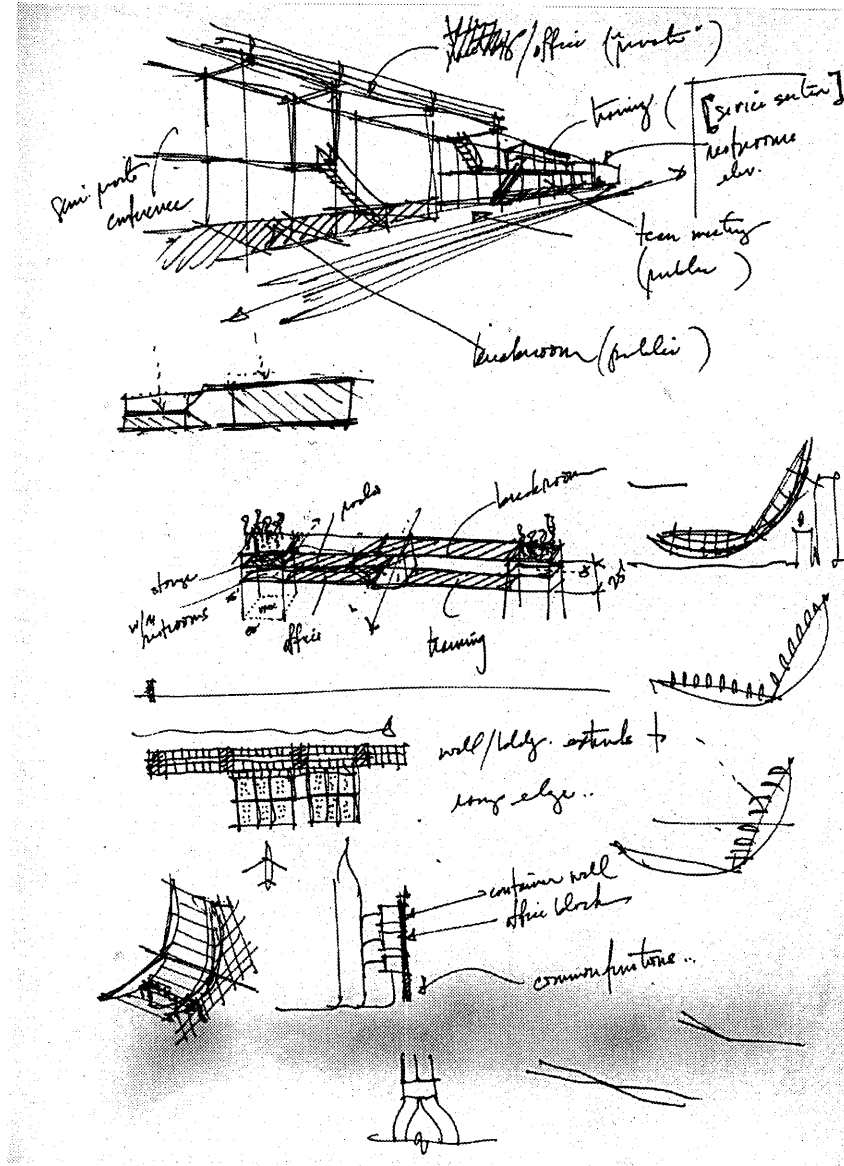












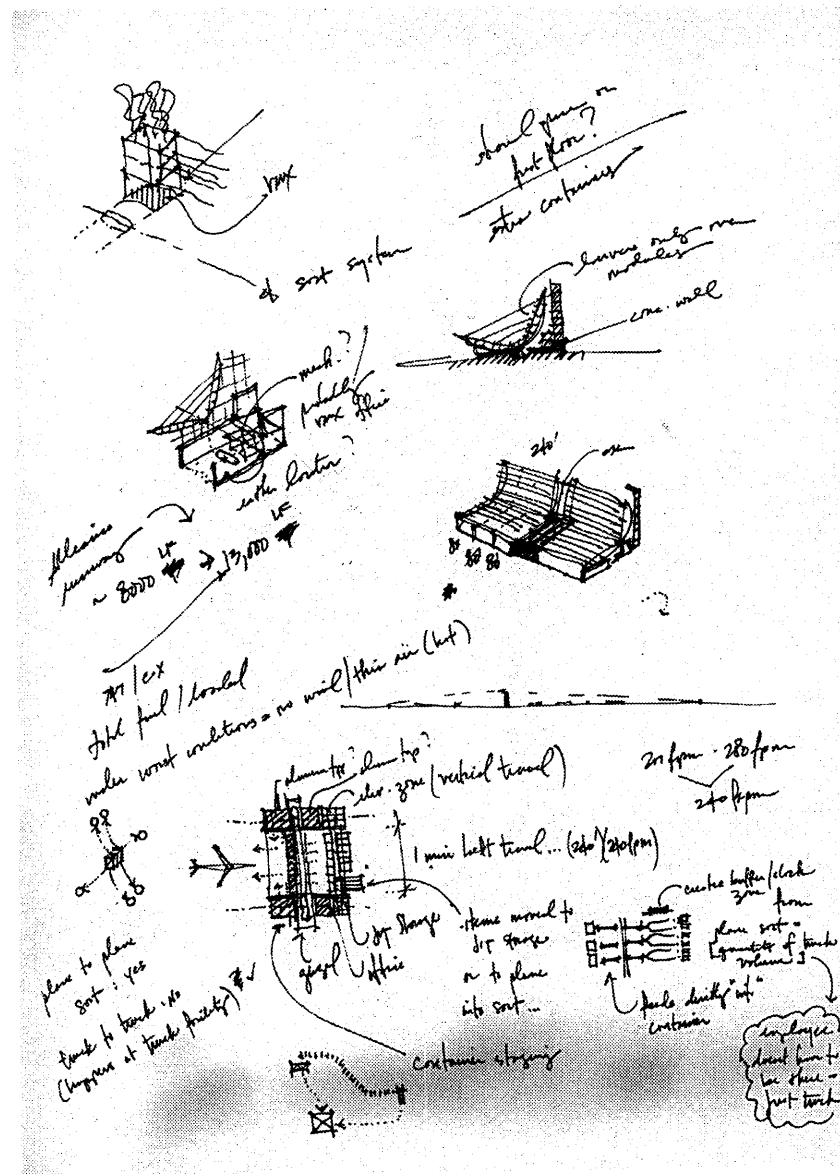


IMAGE CREDITS

All images are by the author unless otherwise noted.

p 11	Alliance Development Company 1997 Marketing Brochure
p 19	Federal Express 1996 Annual Report
p 22	Federal Express 1996 Annual Report
p 23	Federal Express 1996 Annual Report
p 25	Federal Express 1996 Annual Report
p 27	Alliance Development Company 1997 Marketing Brochure
p 28	Alliance Development Company 1997 Marketing Brochure
p 31	Alliance Development Company 1997 Marketing Brochure
p 33	Alliance Development Company 1997 Marketing Brochure
p 35	Alliance Development Company 1997 Marketing Brochure
p 81	Cover of Business Week Magazine; April 29, 1996
p 87	Fortune Magazine; November 10, 1997
p 115	Alliance Development Company 1997 Marketing Brochure
p 117	Rapistan 1997 Marketing Brochure
p 119	Rapistan 1997 Marketing Brochure
p 177	Federal Express 1996 Annual Report

BIBLIOGRAPHY

Becker, Franklin. *The Total Workplace: Facilities Management and the Elastic Organization*. New York: Van Nostrand Reinhold, 1990.

Binder, Stephen. *Corporate Facility Planning: An Inside View for Designers and Managers*. New York: McGraw-Hill, 1989.

Burnham, John. *Integrative Facilities Management*. New York: Irwin Professional Publishing, 1994.

Cherns, Albert B. "The Principles of Sociotechnical Design." *Human Relations*, 29(8), August 1976.

Drury, Jolyon and Falconer, Peter. *Building and Planning for Industrial Storage and Distribution*. New York: Halstead Press Division, 1975.

Goodman, Paul S., Gerri L Griffith, and Deborah B. Fenner. "Understanding Technology and the Individual in an Organizational Context." In Paul S. Goodman, Lee S. Sproull, and Associates, *Technology and Organizations*. San Francisco: Jossey-Bass, 1990.

Kelley, John E. "A Reappraisal of Sociotechnical System Theory." *Human Relations*, 31(12), 1978.

Pasmore, William A. *Designing Effective Organizations: The Sociotechnical Systems Perspective*. New York: Wiley, 1988.

Sigafoos, Robert. *Absolutely Positively Overnight: Wall Street's Darling Inside and Up Close*. Memphis: St. Luke's Press, 1983.

Tompkins, James and White, John. *Facilities Planning*. New York: John Wiley & Sons, 1984.

Trimble, Vance. *Overnight Success: Federal Express and Frederick Smith, Its Renegade Creator*. New York: Crown Publishers, 1993.

Trist, Eric L. "The Evolution of Socio-Technical Systems." *Issues in The Quality of Working Life*, Vol. 2. Toronto, Ontario: Ontario Quality of Working Life Centre, 1981.

Weisbord, Marvin. *Productive Workplaces: Organizing and Managing for Dignity, Meaning and Community*. San Francisco: Jossey-Bass, 1987.

White, Edward. *Facility Programming and the Corporate Architect*. Tuscon: Architectural Media Ltd., 1991.



Specifications: Times New Roman 11pt Layout: Word 97 Paper: Xerox Image Elite 25% Cotton