



Massachusetts Institute of Technology
Engineering Systems Division

ESD Working Paper Series

A Joint Planning, Management and Operations Framework for Airport Infrastructure

Alexandre Jacquillat
PhD Candidate
Engineering Systems Division
Massachusetts Institute of Technology
Cambridge, MA 02139
Email: alexjacq@mit.edu

Vivek Sakhrani
PhD Candidate
Engineering Systems Division
Massachusetts Institute of Technology
Cambridge, MA 02139
Email: sakhrani@mit.edu

Paper submitted for CESUN 2014 - Fourth International Engineering Systems Symposium to be held June 8-11, 2014 at Stevens Institute of Technology.

ESD-WP-2014-04

March 2014

esd.mit.edu/wps

A Joint Planning, Management and Operations Framework for Airport Infrastructure

Alexandre Jacquillat and Vivek Sakhrani

Engineering Systems Division

Massachusetts Institute of Technology

Cambridge, MA 02139

alexjacq@mit.edu, sakhrani@mit.edu

Both authors contributed equally to this paper.

Abstract—Many airports around the world are actively considering development or expansion projects. Such projects can spur tremendous benefits but are investment-intensive and span several decades from conception to completion. We formulate the associated dynamic, complex decision-making problems using a broad systems frame. We propose a conceptual framework that links airport infrastructure investments and airport management and operations in a time-expanded, state-contingent problem. To develop this framework we consider the social and policy objectives for well functioning air transportation infrastructure, the decision levers available to stakeholders, the influence of the institutional field and regulatory context on these decisions, and the key performance measures that operationalize systemilities. Our framework integrates literature from investments under uncertainty, airport demand management, and airport operating procedures. Four case examples of airports in Delhi, Charlotte, London and New York illustrate decision-making in the context of our framework. We argue for a more integrated approach to decision-making while evaluating investments in greenfield airports or capacity expansions.

I. INTRODUCTION

What is the value to society of investing in a new airport, upgrading brownfield facilities, or better utilizing those facilities? How do the trade-offs between these decisions influence performance? Are these decisions separable or coupled and to what extent do the choices depend on the project’s institutional field? Keeney and Raiffa have asked these questions in the context of the complex decision problem of developing airport facilities for Mexico City [1]. The problem is complex because the decision-makers must balance multiple objectives: minimizing costs, increasing capacity, enhancing safety, promoting airline competition, mitigating environmental impact, and enabling regional development. Many airports worldwide currently face these challenges at different stages of their lifecycle.

While the decision-making problem faced by airports around the world remains similar to Keeney and Raiffa’s original framing, some streams of literature and policy dialogue often treat the multiple objectives as independent and decoupled. Analytical tractability is a good motivation for this intentional decoupling. The research community and practitioners have been able to make great strides in areas such as evaluating irreversible investments in real airport assets, enhancing airport project organizations, the design of demand management mechanisms and the development of innovative

operating procedures. We believe, however, that a very focused view often obscures the system-level considerations, and limits our understanding of how decisions impact outcomes.

Since many airports around the world are actively considering development or expansion projects, our motivation is to revisit the formulation of this dynamic, complex decision-making problem using a broader systems frame. We propose a conceptual framework that links airport infrastructure investments and airport management and operations in a time-expanded, state-contingent problem. To develop this framework we consider the social and policy objectives for well functioning air transportation infrastructure, the decision levers available to stakeholders, the influence of the institutional field and regulatory context on these decisions, and the key measures or indicators of system performance.

We select the airport as the unit of analysis. The system boundary is necessarily loosely defined to include both the physical and technological infrastructure assets (technical), as well as the organization responsible for the airport’s management and operations (organizational). This approach puts us squarely in the realm of socio-technical systems, relating our work to the underpinning theme of this forum.

The rest of this introductory section completes the motivation. Section II provides a brief critical review of the relevant literature. Section III describes our conceptual framework. Section IV illustrates the issues with comparative case studies of airports from Delhi, Charlotte, London and New York. Section V concludes.

A. Airports as an investment for meeting social objectives

Airports create value for society by enabling connectivity. An airport is a sophisticated system that is in place to ultimately provide services to individuals, businesses [2], and governments [3]. Demand for airport services is derived from the broader market for air transport, which makes airlines an important client of airports. The economic value of an airport is the sum of the direct value of the aviation activities it enables, indirect value from commercial activities at or near the airport, and induced economic activity in the region [4, 5]. Airports can have an important economic “multiplier effect” through agglomeration [6], thereby contributing to regional economic growth. As gateways to national capitals and urban zones, airports also have a unique reputational significance.

B. Airports as a context for capital investment, management and operations decision-making

We categorize decision-making into three broad categories: investment, management and operations. Capital investments in and financing of airports is the first major category [7], and such decisions are closely tied to the planning effort [8, 9]. Investments can take the form of brownfield expansion and upgrades (*e.g.*, the construction of a new runway, the expansion of passenger terminal buildings), or greenfield airport development [10, 11]. Investments can also take the form of developing air traffic management technologies [12, 13].

In the second category, managing airport infrastructure involves the design of a demand management mechanism for allocating capacity to the airlines. There are important jurisdictional policy differences in this regard. Most of the busy airports worldwide operate under slot control policies, carefully allocating valuable airport capacity, to prevent flight schedules from exceeding capacity. Airports declare a value of capacity and allocate a corresponding number of slots, typically through a bi-annual administrative procedure. In contrast, policy in the US weakly constrains airline access to airports [14]. Only the three New York airports (JFK, EWR and LGA) operate under schedule limits, albeit loosely enforced, often through voluntary compliance from the airlines. These policy differences affect the behavior and performance of airports as systems.

Finally, the third category covers airport operations. It consists of utilizing available infrastructure to taxi and operate the flights, and move passengers, ground crews and service vehicles. The underlying objective is to maximize the airport's operating efficiency, while satisfying safety requirements. Section II unpacks decision-making in these three categories in more detail.

C. Airports as a manifestation of institutional field

Airports exist in an institutional field—an environment with a unique combination of norms, regulatory rules and laws, and cultural approaches to decision-making [15]. These environmental features play out in the strategic planning process (different guidelines and process for master planning [9]), the technical design attributes of an airport (*e.g.*, the design of aircraft contact points [16]), airline access to the airport (different approaches to airport demand management, highlighted above), and airport operations (*e.g.*, different degrees of privatization of Air Navigation Service Providers [17]). An important crosscutting theme across these areas is the role of the private sector in building, owning, managing and operating airports. In the US, while the private sector is intimately involved at many large airports, the public sector still owns the land, or is directly responsible for airport planning and operations where the public authority model is in use. Airport privatizations in countries like the UK, France and Spain imply that the private sector has end-to-end responsibility typically under very long term concession agreements. The degree of privatization of airport services creates incentives and allocates

risks, affecting how and when capacity expansion may occur, and the level and quality of airport services [18, 19, 20].

D. Airports as systems with emergent performance

An airport as a system has many sub-systems, each of which contributes to its overall performance. Best practice suggests that there are many indicators that airport organizations should use to monitor airport performance [21, 22]. Some of these are core indicators and measure performance of the airport as a whole (*e.g.*, safety, airfield operations, on-time performance, cargo, financial, parking, service quality), whereas others reside at the sub-system level (*e.g.*, airfield electricity consumption, employee job satisfaction). The many departmental sub-systems interact to result in the airport's overall emergent behavior. In Section III, we link performance metrics to desirable system properties, or “ilities”, which are derived from social and policy objectives.

II. LITERATURE REVIEW

Airport infrastructure planning is an example of a broader class of problems involving irreversible investments in real assets under uncertainty [23]. Airports are long-horizon relationship-specific investments; once stakeholders have committed and infrastructure is built, the project cannot be easily redeployed without extensive sunk costs, time and effort [24].

The problem can be formulated as a multi-objective, multi-stakeholder, time-expanded decision. A planner's viewpoint focuses on enhancing social value or welfare [1, 25]. A firm's view translates to wealth maximization, *i.e.*, maximization of the net present value of future returns and investment opportunities. The planner's multi-objective frame can subsume the firm's single objective view, but this creates trade-offs. In a real options sense, the first investment (in a new airport) unlocks the option to invest in future growth opportunities. For firms, this can create a competitive game-theoretic situation, since airports nearby can capture rents in the context of growing demand in the region [26]. An airport's expansion strategy may thus conflict with the planner's overall intent to enhance welfare in the region. Finally, the problem of investment recovery raises similar trade-offs related to the endogeneity in airport-related taxes and fees and how they impact passenger decisions [27].

The problem is complicated by the significant uncertainty affecting the potential value of an airport, including uncertainties regarding demand for air transport [28], passenger travel choices [29], and fuel price volatility [30]. This uncertainty underscores two critical features of the infrastructure planning problem. First, Bayesian learning takes place through the use of information on uncertainties and competitors' actions revealed over time [31]. Second, a flexible airport design might enable follow on investments and actions as future uncertainties resolve. A growing literature on flexibility in design [32] and project governance addresses the design process needed to operationalize flexibility in airport projects [33, 16].

The broader literature on access regulation [34] deals with the problem of airport demand management, trading off ca-

capacity utilization and flexible airline competition with on-time performance. On the one hand, slot control policies may underuse available capacity [35] and create barriers to airline competition [36, 37]. On the other, the unrestricted approach to airport access in the US causes significant delays, imposing costs on airlines, passengers and other stakeholders [38]. This trade-off has created important research questions. The operations vein quantifies airport capacity [39, 40] and models the effects of demand management on airline schedules [41, 42] and on airport congestion [43, 44]. The economic vein studies how the use of airport infrastructure by competing profit-maximizing operators creates the potential for congestion externalities. The “tragedy of the commons” issue arises because airlines sometimes might have incentives to overuse the airport as a public resource by scheduling more flights than available capacity. The economic literature aims to design welfare-maximizing capacity allocation strategies, given the specificities of the airline industry and of airline competition [45, 46, 47].

Finally, the problem of airport capacity utilization involves designing operating procedures to enhance the efficiency of airport operations, for a given physical airport layout and a given schedule of flights. First, the Air Traffic Flow Management (ATFM) literature designs a set of tactical interventions to optimize the flow of aircraft at the national or regional level. Interventions of this type include the control of runway configurations at major airports, the ground holding of aircraft and the optimization of en-route operations (see, *e.g.*, [48, 49, 50, 51]). Second, the Air Traffic Control (ATC) literature aims to optimize the sequencing and spacing of aircraft at the operational level [52]. The combination of the two approaches reduces the magnitude and costs of flight delays substantially, while satisfying equity considerations across airlines [53].

In conclusion, a number of academic communities have addressed the problems of planning, managing and operating airport infrastructure. Their efforts have undoubtedly resulted in important research advances and practice improvements. The different bodies of work are quite disintegrated however. Infrastructure planning primarily uses high-level traffic forecasts and does not incorporate the endogenous links between airport infrastructure and airline schedules, airport operating procedures. Airport demand management generally relies on a single-value estimate of airport capacity and thus treats airport infrastructure and operating procedures as constant. Airport operations focus on tactical and operational interventions, given a physical airport layout and for a given schedule of flights. In this paper, we argue for a more integrated approach that acknowledges the close links between these different levels of analysis and intervention.

III. PROBLEM CONCEPTUALIZATION

A. Conceptual Representation of Airport System Performance

The problem of infrastructure planning, management and operations involves defining social objectives, monitoring the system’s performance trajectory, and intervening to keep it in

line with desirable social outcomes. Assessing the “performance” of any complex socio-technical system is challenging because it encompasses several, often competing dimensions, diverse stakeholder perspectives, and spans multiple time scales. In this section, we unpack several design and structural features of airports as systems and conceptually represent how those features can enhance performance.

We discuss system performance using the concept of *ilities*, defined as “desired properties of systems [...] that often manifest themselves after a system has been put to its initial use [and that] concern wider system impacts with respect to time and stakeholder” [54]. We identify the following emergent properties as critical to airport performance. The list is neither exhaustive nor unique. We simply intend to characterize the competing objectives that stakeholders of airport systems face worldwide.

- **Safety:** As the foremost responsibility of civil aviation authorities, safety is paramount in any air traffic management system. Records show that airports have achieved extraordinary safety levels in recent decades [55].
- **Efficiency:** The number of flights operating at an airport, per unit of time, characterize its efficiency and imply its realized capacity. Efficiency is often measured as the maximum throughput capacity, defined as the average number of aircraft movements that can be operated per unit of time under continuous demand [16].
- **Reliability:** The airport’s ability to provide high levels of service consistently indicates its reliability. Schedule reliability characterizes its ability to operate its schedule of flights, as measured through diverse on-time performance metrics (*e.g.*, arrival delay, taxiing delay, etc.).
- **Flexibility:** Airports are subject to dramatic and unexpected changes in the airline industry (*e.g.*, mergers, hub developments, frequency competition) that create significant forecast uncertainty. Flexibility defines the system’s ability to accommodate short-term volatility and long-term structural variations in traffic. It encompasses the notions of scalability and adaptability.
- **Scalability:** This is the ability of an airport system to scale up to increasing demand over long periods of time. A given airport design must typically serve its functions over many decades. It thus has to anticipate and accommodate growth (or declines) in traffic and demand.
- **Adaptability:** This is the ability of an airport to respond to shorter-term variations in airline demand, *e.g.*, airline market penetration, frequency competition, etc. The airport’s adaptability depends on how quickly and effectively it manages to adapt to such variations.
- **Sustainability:** This system property is often defined as the 3 “E”s: Economic development, Environmental protection, social Equity. Sustaining high levels of Economic growth is related to other airport properties (*e.g.*, efficiency, scalability). The airport must minimize its local (*e.g.*, noise) and global (*e.g.*, emissions) environmental footprints. Aligning organizational goals with the needs

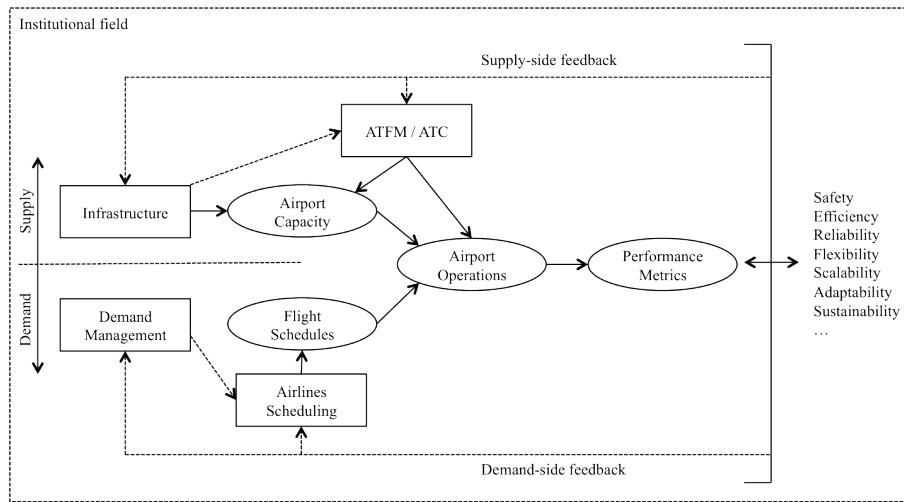

Fig. 1: A conceptual framework linking airport system decisions to performance metrics and system 'ilities'

and values of local communities is the social component of sustainability.

Complex interactions exist among these properties. Some are positively correlated and improvements in one may therefore lead to improvements in others. For instance, reduced delays may improve reliability as well as positively impact safety and sustainability. There also exist trade-offs across other dimensions; traffic growth can increase peak-hour scheduling levels, for example. Airports may thus see enhanced incentives to improve their operating efficiency (number of flights per unit time) but cascading delays will lower schedule reliability.

We can think of most airport capacity restrictions as limitations in their scalability, *i.e.*, system failures to meet increasing demand. This is the main cause of airport congestion, implying low schedule reliability and diversions of traffic. Many busy airports worldwide thus face the critical challenge of designing investments and managerial and operational interventions to mitigate the demand-capacity imbalance.

We present in Figure 1 a general framework linking concepts of airport system decisions to performance metrics and emergent 'ilities'. Squares represent decision levers, whereas ovals represent the observed behaviors. The framework spans several time frames with strategic, tactical and operational interventions, along with a number of stakeholders. The institutional field in which the airport system is embedded shapes the system's behavior.

The first decision lever consists of investing in physical and/or technological infrastructure. Such projects expand airport capacity, and thus the *supply* of infrastructure. The second lever consists of designing or modifying a demand management mechanism to better match airline flight schedules with available airport capacity. This mechanism can be administrative (*e.g.*, slot control) or economic (*e.g.*, congestion pricing, slot auctions). It affects airline scheduling incentives and thus flight schedules, *i.e.*, *demand* for airport infrastructure. The third lever consists of enhancing the efficiency of airport operations through improvements in operating procedures, namely Air Traffic Flow Management (ATFM) procedures at

the tactical level and Air Traffic Control (ATC) procedures at the operational level.

These three types of intervention are tightly interconnected. On the supply side, the physical and technological capacity of the airport strongly constrain its operating procedures. Any investment in airport infrastructure is likely to alleviate these constraints and thus improve system performance. Airport operating procedures are not exogenous however; they depend on the physical layout of the airport, on the surrounding airspace and on the characteristics of the air traffic management systems. Infrastructure investments will thus also spur a number of iterative improvements in air traffic management to make the best possible use of capacity. In other words, infrastructure enhancements attempt to increase *potential* airport capacity, while operating procedures aim to maximize *effective* airport capacity. Given the complexity of air traffic management systems and the endogeneity of airport operating procedures, there is no clear mapping between *ex ante* infrastructure investment (potential capacity) and *ex post* impact on airport operations (effective capacity).

On the demand side, airlines' networks and flight schedules also depend endogenously on effective airport capacity. Infrastructure investments and operational enhancements may attract airline traffic at an airport, but their exact consequences on flight schedules are difficult to predict because they depend on airline business strategies that also evolve. Conversely, infrastructure investments and airport operations depend on how airlines are making use of available capacity. For instance, airport capacity depends on the mix of aircraft used by the airlines, while capacity utilization procedures will depend on how arrivals and departures are scheduled over the course of a day. In the short run, airline scheduling decisions will impact airport operations, whereas the evolution of airline demand in a metropolitan area will motivate long run infrastructure investments. In summary, the planning, management and operations of airport infrastructure are not stand-alone problems but are linked by the irreversibility of physical infrastructure, sunk economic costs of previous investments, and complex,

endogenous and multi-stakeholder dynamics.

We can get a sense of an airport system’s behavior in terms of the “ilities” presented above by observing its performance metrics. Whereas a specific intervention may directly result in some properties, many observed behaviors emerge from unintended consequences of investments and decisions. Moreover, airport planning, management and operations are dynamic problems that span many years of operations. For this reason, we add feedback loops that dynamically revise capacity estimates and inform airline schedule planning, based on observed system performance. In turn, system performance also informs, at a higher level, future infrastructure investments and demand management policies.

Finally, we emphasize that the system’s behavior strongly depends on the institutional field and regulatory environment in which the airport is embedded. Factors such as the extent of competition in the airline industry, the degree of centralization in infrastructure planning and management, the mandate of civil aviation authorities to impose demand management measures, will influence the dynamics and performance of the airport system.

B. A Representation of the Decision-Making Problem

Having unpacked the interdependencies, we address in this section the dynamic nature of the decision-making problem. Infrastructure investments present a well known natural trade-off in which significant system benefits accruing over a long horizon are available only if investments costs and resources are expended in the near term. The many possible benefits include better using technology and skilled professional labor, enabling market penetration and airline competition by reducing pressure on flight schedules, and meeting regional development goals by supporting long-term traffic growth. These benefits accrue after undertaking investment projects spanning several decades from conception to completion, subject to environmental, socioeconomic and political constraints. Further, costs and benefits are multidimensional and uncertain and a diverse set of stockholders may perceive them differently. We use decision trees to characterize the nature and timing of the decisions, first for a new greenfield airport and then for capacity expansion at existing airports.

A greenfield airport project involves deciding whether to build (yes or no), what to build (the airport’s design), and when to build (timing of construction). Figure 2 is a schematic representation of the greenfield airport problem. Squares denotes decision choices or options, and circles correspond to observed outcomes. The decision tree structure assumes a discrete repetition of observations followed by decisions (*e.g.*, decisions and observations are made every year), but the dynamics of the system are more continuous in reality. Each decision choice brings associated costs and benefits, which depend on the state of the system at the time of the decision. Our stylized decision space includes (i) a “Do Nothing” option to represent the status quo, (ii) the investment in learning through activities such as a research study, a feasibility study, etc. (“Exploration”), (iii) the investment in alternative tech-

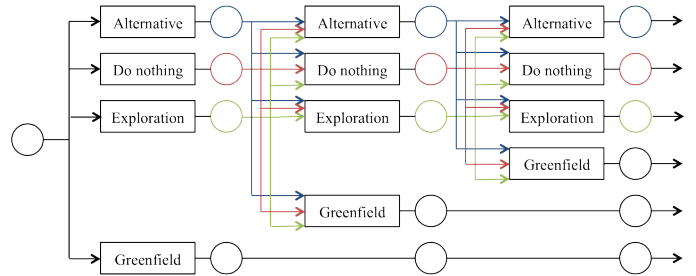

Fig. 2: The decision tree for a greenfield project with a range of options to represent the opportunity cost of infrastructure investments

nologies or projects (“Alternative”) and (iv) the construction of a new airport with a specific design concept (“Greenfield”). We select these options to emphasize the opportunity cost of any infrastructure investment and motivate the use of a broad system boundary to capture a diverse set of interests.

Traditional cost-benefit analysis argues that stakeholders should invest if the expected discounted reward exceeds projected discounted costs. In our case, both expected rewards and costs will depend on the specific design concept, *e.g.*, plans for the size of passenger buildings, the number and layout of runways, ability to expand in future, etc. Since infrastructure development is tied to social, political and organizational objectives, the stakeholder’s viewpoint (welfare-maximizing vs. wealth-maximizing) and the contractual structure of the project will also influence the project’s payoffs.

The question of when to build considers the nature and extent of uncertainty in both the costs and benefits of the project. On the one hand, early investments may result in a larger Net Present Value if the project is ready and available to capture the benefits of the demand that materializes. On the other, delaying the decision to build may be valuable in some cases. This potential “value of waiting” stems from two factors: the irreversibility and path dependency of long-term investments, and the dynamic resolution of uncertainties over time. First, since relationship-specific investment decisions cannot be easily reversed, a decision to build commits the system to a course of action, thereby closing of the other decision alternatives. Figure 2 depicts this irreversible commitment by the absence of control over the system when a greenfield airport is being constructed. Note that building in flexibility in the design of the system may enable certain dynamic controls [16] and alleviate concerns, but the trade-off remains in the sense that executing a build decision thereafter considerably restricts the set of options available to the decision-makers. Second, the dynamic resolution of uncertainty over time impacts the optimal timing of infrastructure decisions. The following example illustrates this. Let’s assume that a project costs 100 units “today”, and the value of the project “tomorrow” is 200 units with a certain probability p and 50 units with probability $1 - p$. The net present value of the project, an expectation, is equal to: $NPV = -100 + r(200p + 50(1 - p))$, where r is the discount factor. The traditional approach suggests that the decision-maker should execute if the expected NPV is positive. Assuming that the uncertainty regarding the reward is resolved

in the next “period”, the best strategy would consist of waiting one period, and undertaking the project if the value of the project is found to be 200 units. This logic extends over a number of time periods. This very simple example illustrates two important points. First, the “value of waiting” depends on the nature and extent of uncertainty. Second, it also depends on how quickly and certainly uncertainty gets resolved.

We also distinguish between two types of uncertainty: random shocks and structural uncertainty. Random shocks are the exogenous sources of uncertainty, such as changing technology costs, population and economic growth. Structural uncertainty, in contrast, is the uncertainty endogenous to the project, *e.g.*, project feasibility, future costs, demand for infrastructure, etc. Both types can be of a technical, social or organizational nature. In our framework, the “Do nothing option” is a way to capitalize primarily on the potential resolution of exogenous uncertainty. The Exploration option may address both types of uncertainty. The cost of revealing information and resolving uncertainties is relatively minor in comparison with the sunk costs of investment due to a build decision.

In summary, we have stylized the investment in a greenfield airport as a dynamic decision-making problem with a long-term investment option and short-term non-investment alternatives. The former can spur tremendous benefits of new infrastructure, but comes at significant cost and represents a technological and organization commitment that spans many decades. The latter category aims to leverage the value of waiting and learning.

We now consider the problem of capacity expansion at an existing, capacity-constrained airport subject to significant delays and growing demand. The corresponding stylized decision problem in Figure 3 shows four decision options: (i) a status quo “Do nothing” option as in the previous greenfield airport case, (ii) changes in the demand management rules (“Demand Management”), (iii) operational enhancements resulting from investments in the Air Traffic Management system (“ATFM/ATC Investments”) and (iv) the expansion of existing infrastructure (“Capacity Expansion”). For the sake of clarity, we omit the “Exploration” and “Alternative” options shown in Figure 2, but these options are also available as above. Figure 2 and Figure 3 are quite similar, exhibiting overlaps between the greenfield project and brownfield expansion problem such as the irreversibility of infrastructure decisions and the role of uncertainty in decision-making. However, the capacity expansion problem has a fundamentally different structure because of the nature of available alternatives and the sequence of decisions.

First, the nature of alternatives and corresponding tradeoffs are different. At existing airports, short-term and medium-term congestion mitigation options are available as alternatives to infrastructure expansion. Operational enhancements can be deployed to alleviate the magnitude and/or the costs of flight delays. Demand management can better match airline demand with available capacity at busy airports. It is worth noting that the trade-offs associated with demand management differ from those associated with other options, since capac-

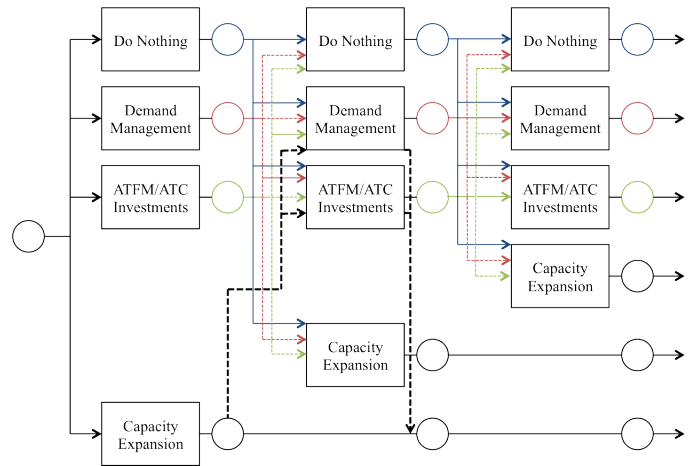

Fig. 3: The decision tree for a brownfield capacity expansion project with different trade-offs and path dependencies

ity expansion and operational enhancements increase either *potential* or *effective* airport capacity. All stakeholders can benefit (especially when ATFM and ATC algorithms incorporate equity considerations). This, however, has a development and implementation cost. In contrast, demand management imposes lower implantation costs, but higher economic costs due to the scheduling constraints that it creates. Integrating operational and economic considerations into the decision-making problem provides decision-makers with a more complete understanding of the available options.

Second, the timing and sequencing of decisions is more complex. As in the case of a greenfield airport, alternatives to capacity expansion have much shorter implementation timeframes. For instance, innovative traffic management procedures and demand management mechanisms could be implemented successfully in a few months. The path-dependencies in these alternatives are not primarily technical or design-related, as in the case of infrastructure expansion, but are social and organizational. The implementation of a new traffic management technology may require extensive integration with the existing air traffic management systems. Demand management may spur airlines investments in equipment and modified flight schedules in response to changes in the regulatory environment. Early decisions in non-expansion alternatives may thus restrict the set of future interventions, as represented by the dashed lines corresponding to patch changes in Figure 3.

Third, the alternative options are *not* mutually exclusive. In fact, airports commonly simultaneously activate several levers corresponding to these decision alternatives. For instance, operational enhancements and infrastructure expansion—or the absence thereof—might motivate revisions in demand management policies. As a result, infrastructure investments can no longer be assessed independently from alternatives. This is represented in our framework by the black, dashed arrows between infrastructure expansion and demand management and operational alternatives. Note that the benefits of each decision are not decoupled. An important argument in favor of the current demand management approach at US airports is

that any type of demand management, by reducing pressure on airport capacity, would lower incentives to expand capacity or to develop innovative air traffic management procedures. As discussed in Section III-A, we argue for a more integrated approach in this multi-dimensional decision-making problem. One approach is to investigate capacity enhancements options, while maintaining a degree of freedom in the design of the demand management mechanism.

IV. CASE DISCUSSION

We now briefly discuss the approaches adopted at several airports worldwide to address the challenges outlined in this paper. We focus on four airport systems at different stages of their lifecycles and in different jurisdictions. We present successively a greenfield project (the New Delhi Indira Gandhi Airport), two capacity expansion projects (the Charlotte Douglas Airport and the London airport system) and congestion mitigation at New York airports, where infrastructure expansion is not feasible. These cases are subject to ongoing research.

A. The Indira Gandhi Airport (DEL)

The Indira Gandhi International Airport (DEL) in India's capital, New Delhi, began operating as a concession-based infrastructure public-private partnership (PPP) in 2006. The central government of India and its Planning Commission wanted to address the poor state of the Indian aviation sector under the public sector operator, and resorted to airport privatization. This case is an example of changing institutional field as the government created new laws and regulations to enable private sector participation in airport investment, management and operations. The project involved investment in new runways, and international and domestic terminals, while maintaining operations at the old terminals. On the whole, the project is more greenfield than brownfield because of the extent of capacity investments and dramatic overhaul in technology and operations. Although the planning process dated back to 1998, the 30-year concession agreement was signed in 2006 with construction and ramp up ending in 2010. The total project cost exceeded its approved budget of \$1.46 billion by approximately 40%, resulting in very high passenger taxes and fees as well as high landing fees for airlines. This has raised questions regarding the design of the airport. But it has served dramatic increases in demand since 2006, thereby enhancing social welfare in the capital region. As a fast track project, the airport company completed DEL in 37 months and achieved an important reputational and policy objective as it became operational in time for the 2010 Commonwealth Games [56].

B. The Charlotte Douglas Airport

The Charlotte Douglas International Airport is a one of the ten busiest airports in the United States. The airport underwent the construction of Runway 18R|36L in 2007, which opened in January 2010 for traffic. The final cost of the project (\$325 million) exceeded its original estimate (\$90 million) by a

factor of three and a half. The federal government funded approximately 40% of the project; the rest was funded through a \$3 fee added to the cost of each ticket. Interestingly, the opening of the runway resulted in a large surge in demand. Approximately 8% more flights were operated in 2011 and 2012 than before new runway was opened, even though the nation-wide demand for air travel has declined over the same period of time. The *ex post* assessment of the project suggests that infrastructure expansion has resulted in an increase in effective capacity by 5% to 15%. Whereas this capacity increase does alleviate current and future congestion, mild demand management measures may have achieved larger delay reductions [57].

C. The London Airport System (LHR, LGW)

The London area is served by two primary airports: Heathrow and Gatwick, as well as three secondary airports: City, Luton and Stansted. These airports are capacity constrained, highly congested, and impact the local environment with noise and greenhouse gas pollutants. Heathrow is considered effectively full, and Gatwick operates at more than 85% of its maximum capacity; the others are expected to operate at full capacity by 2030. A “do nothing” strategy will cost the regional economy an estimated £18 billion in direct economic impacts, and up to £45 billion in wider indirect impacts. UK's Airport Commission has recently evaluated 52 different proposals including short- to mid-term options covering operational enhancements, scheduling changes and regulatory interventions, as well as longer-term options including new runways or a new greenfield airport. Given the high underlying demand, investments in additional airport capacity were recommended. New runway options currently look the most attractive for delivering more capacity in the long-term, with one runway design possibility at Gatwick and two design concepts for Heathrow shortlisted for further assessment [58]. While the option of a greenfield airport is still on the table, it presents some significant challenges and a possible cost of 5 times that of the new runway options.

D. The New York Airport System (JFK, EWR, LGA)

New York City is served by three primary commercial airports: JFK, Newark (EWR) and LaGuardia (LGA). These airports are subject to large—and growing—local and international demand. At the same time, their capacity is limited by existing infrastructure and the congestion of the surrounding airspace. In contrast to the London system, any type of physical infrastructure expansion is infeasible in New York City. Two options therefore remain available: demand management and operational enhancements.

Since the phase-out of the High Density Rule, effective January 1, 2007, JFK, EWR and LGA are subject to schedule limits stemming from temporary orders from the Federal Aviation Administration. However, these limits were found too high to effectively mitigate congestion and it was recommended that they be reexamined [59, 60, 16]. More broadly, the question of effective demand management in the New York area raises

important questions on the long-term costs and benefits to the aviation sector and the broader public [41, 42, 61] and remains an open question. At the same time, New York airports have implemented innovative procedures to alleviate the delay costs at the operational level. Most important, departure metering techniques have effectively reduced surface congestion, hence the environmental footprint of airport operations, while improving the level of service provided to air travelers. However, the benefits of such operational measures are limited when demand exceeds capacity by any substantial margin.

In conclusion, the New York airport system suffers from a lack of scalability. Congestion mitigation requires the implementation of a demand management mechanism or operational enhancements—or a combination thereof.

V. CONCLUDING REMARKS

In this paper, we have critically reviewed and integrated the literature on investments under uncertainty, airport demand management, and airport operating procedures. We have proposed an integrated framework for the planning, management and operations of airport infrastructure that underscores the complex interdependencies between different levers and system performance, characterized by several “ilities”. We have then proposed a dynamic framework for infrastructure investments that highlights the roles of uncertainty and learning and the importance of carefully investigating available alternatives, including policy, managerial and operational interventions. We have finally applied this framework in a combined presentation of four cases of airports in Delhi, Charlotte, London and New York subject to ongoing research.

In light of the discussion provided in this paper, we can draw several recommendations towards a systems approach to the problems of planning, managing and operating airport infrastructure.

- Engage with relevant stakeholders and identify the objectives of the infrastructure system
- Identify the sources and extents of uncertainty surrounding the system
- Identify and invest in opportunities for learning
- Identify the sources of uncertainty that might be alleviated through increased flexibility in the design of the system
- Identify clearly the alternatives to the infrastructure investment, including demand management and operational enhancements, and the trade-offs associated with them
- Invest in existing approaches to optimizing each alternative
- Develop and invest in original approaches to integrating all alternatives
- Engage in post-implementation assessments and make revisions, whenever possible and necessary

REFERENCES

- [1] R. Keeney and H. Raiffa, *Decisions with Multiple Objectives : Preferences and Value Tradeoffs*. Cambridge University Press, 1993.
- [2] Cushman & Wakefield, “European Cities Monitor 2009,” Tech. Rep., 2009.
- [3] The World Bank, “Investment in air transport infrastructure,” The World Bank Public-Private Infrastructure Advisory Facility, Tech. Rep., 2010.
- [4] J. Brueckner, “Airline Traffic and Urban Economic Development,” *Urban Studies*, vol. 40, no. 8, pp. 1455–1469, 2003.
- [5] S. Appold and J. Kasarda, “The Airport City Phenomenon: Evidence from Large US Airports,” *Urban Studies*, vol. 50, no. 6, pp. 1239–1259, 2012.
- [6] D. Graham, “Agglomeration, Productivity and Transport Investment,” *Journal of Transport Economics and Policy*, vol. 41, no. 3, pp. 317–343, 2007.
- [7] J. Jorge and G. de Rus, “Cost–benefit Analysis of Investments in Airport Infrastructure: A Practical Approach,” *Journal of Air Transport Management*, vol. 10, no. 5, pp. 311–326, 2004.
- [8] P. Forsyth, “The Impacts of Emerging Aviation Trends on Airport Infrastructure,” *Journal of Air Transport Management*, vol. 13, no. 1, pp. 45–52, 2007.
- [9] Ricondo & Associates, “Strategic Planning in the Airport Industry,” ACRP report, Tech. Rep., 2009.
- [10] P. Beria and A. Scholz, “Strategies and Pitfalls in the Infrastructure Development of Airports: A comparison of Milan Malpensa and Berlin Brandenburg International Airports,” *Journal of Air Transport Management*, vol. 16, no. 2, pp. 65–73, 2010.
- [11] H. Smit, “Infrastructure Investment as a Real Options Game: The Case of European Airport Expansion,” *Financial Management*, vol. 32, no. 4, pp. 27–57, 2003.
- [12] Federal Aviation Administration, “NextGen Implementation Plan,” Tech. Rep., 2013.
- [13] European Commission, “Commission Staff Working Paper on Preparing a Deployment Strategy for the Single European Sky Technological Pillar,” Tech. Rep., 2010.
- [14] A. Odoni, *The Global Airline Industry*. John Wiley & Sons Ltd., 2009, ch. The International Institutional and Regulatory Environment, pp. 19–46.
- [15] W. Scott, “The Institutional Environment of Global Project Organizations,” *Engineering Project Organization Journal*, vol. 2, no. 1-2, pp. 27–35, 2012.
- [16] R. de Neufville and A. Odoni, *Airport Systems: Planning, Design and Management*, 2nd ed. McGraw-Hill, 2013.
- [17] Government Accountability Office, “Air Traffic Control: Characteristics and Performance of Selected International Air Navigation Service Providers and Lessons Learned from Their Commercialization,” Tech. Rep. GAO-05-769, 2005.
- [18] L. Basso and A. Zhang, “Pricing vs. Slot Policies when Airport Profits Matter,” *Transportation Research Part B*, vol. 44, pp. 381–391, 2010.
- [19] J. Martin and M. Pilar Socorro, “A New Era for Airport Regulators through Capacity Investment,” *Transportation Research Part A: Policy and Practice*, vol. 43, no. 6, pp. 618–625, 2009.
- [20] D. Gillen, “The Evolution of Airport Governance and Ownership,” *Journal of Air Transport Management*, vol. 17, pp. 3–13, 2011.
- [21] R. Hazel, J. Blais, T. Browne, and D. Benzon, “Resource Guide to Airport Performance Indicators,” ACRP report, Tech. Rep., 2011.
- [22] TransSolutions, Futterman Consulting, Harris Miller Miller & Hanson, Inc., and J. Rakas, “Defining and Measuring Aircraft Delay and Airport Capacity Thresholds,” ACRP report, Tech. Rep., 2014.
- [23] A. Dixit and R. Pindyck, *Investment under Uncertainty*. Princeton University Press, 1994.
- [24] O. Hart, *Firms, Contracts, and Financial Structure*. Oxford University Press, 1995.
- [25] —, “Incomplete Contracts and Public Ownership: Remarks, and an Application to PublicPrivate Partnerships,” *The Economic Journal*, vol. 113, no. 486, pp. C69–C76, 2003.
- [26] S. Grenadier, “Option Exercise Games: The Intersection of

- Real Options and Game Theory,” *Journal of Applied Corporate Finance*, vol. 13, no. 2, pp. 99–107, 2000.
- [27] J. Karlsson, A. Odoni, C. Geslin, and S. Yamanaka, *Advances in Airline Economics: The Economics of Airline Institutions, Operations and Marketing*. Elsevier, 2007, vol. 2, ch. Airline Ticket Taxes and Fees in the United States and European Union, pp. 255–274.
- [28] I. Kincaid, M. Tretheway, S. Gros, and D. Lewis, “Addressing Uncertainty about Future Airport Activity Levels in Airport Decision making,” ACRP report, Tech. Rep., 2012.
- [29] B. Parrella, “Understanding Airline and Passenger Choice in Multi-airport Regions,” ACRP report, Tech. Rep., 2013.
- [30] W. Spitz and F. Berardino, “Impact of Jet Fuel Price Uncertainty on Airport Planning and Development,” ACRP report, Tech. Rep., 2011.
- [31] S. Grenadier, “Information Revelation through Option Exercise,” *Review of Financial Studies*, vol. 12, no. 1, pp. 95–129, 1999.
- [32] R. de Neufville and S. Scholtes, *Flexibility in Engineering Design*. MIT Press, 2011.
- [33] N. Gil and B. Tether, “Project Safeguards: Operationalizing Option-like Strategic Thinking in Infrastructure Development,” *IEEE Transactions on Engineering Management*, vol. 56, no. 2, pp. 257–270, 2009.
- [34] J. Laffont and J. Tirole, *Competition in Telecommunications*. MIT Press, 2000.
- [35] T. Morisset and A. Odoni, “Capacity Delays and Schedule Reliability at Major Airports in Europe and the United States,” *Transportation Research Record*, vol. 2214, pp. 85–93, 2011.
- [36] NERA, “Study to assess the effects of different slot allocation schemes,” National Economic Research Associates, Tech. Rep., 2004.
- [37] A. Czerny, P. Forsyth, D. Gillen, and H. Niemeier, *Airport Slots*. Ashgate Publishing Ltd, 2008.
- [38] M. Ball, L. Ausubel, F. Berardino, P. Cramton, G. Donohue, M. Hansen, and K. Hoffman, “Market-based Alternatives for Managing Congestion at New York’s LaGuardia Airport,” in *AirNeth Annual Conference*, 2007.
- [39] E. Gilbo, “Airport Capacity: Representation, Estimation, Optimization,” *IEEE Transactions on Control Systems Technology*, vol. 1, no. 3, 1993.
- [40] I. Simaiakis, “Analysis, Modeling and Control of the Airport Departure Process,” Ph.D. dissertation, Massachusetts Institute of Technology, 2012.
- [41] V. Vaze and C. Barnhart, “Modeling Airline Frequency Competition for Airport Congestion Mitigation,” *Transportation Science*, vol. 46, no. 4, pp. 512–535, 2012.
- [42] N. Pyrgiotis and A. Odoni, “On the Impact of Scheduling Limits: A Case Study at Newark International Airport,” *Transportation Science*, vol. Forthcoming, 2014.
- [43] N. Pyrgiotis, K. Malone, and A. Odoni, “Modelling Delay Propagation within an Airport Network,” *Transportation Research Part C*, vol. 27, pp. 60–75, 2013.
- [44] A. Jacquillat, “A Queuing Model of Airport Congestion and Policy Implications at JFK and EWR,” Master’s thesis, Massachusetts Institute of Technology, 2012.
- [45] J. Brueckner, “Airport congestion when carriers have market power,” *American Economic Review*, vol. 92, no. 5, pp. 1357–1375, 2002.
- [46] C. Mayer and T. Sinai, “Network Effects, Congestion Externalities, and Air Traffic Delays: Or Why Not All Delays Are Evil,” *American Economic Review*, vol. 93, no. 4, pp. 1194–1215, September 2003.
- [47] S. Morrison and C. Winston, “Another Look at Airport Congestion Pricing,” *American Economic Review*, vol. 97, no. 5, pp. 1970–1977, 2007.
- [48] A. Odoni, *Flow Control of Congested Networks*. Springer-Verlag, 1987, ch. The Flow Management Problem in Air Traffic Control.
- [49] P. Vranas, D. Bertsimas, and A. Odoni, “The Multi-airport Ground-holding Problem in Air Traffic Control,” *Operations Research*, vol. 42, no. 2, pp. 249–261, 1994.
- [50] A. Jacquillat, A. Odoni, and M. Webster, “Airport Congestion Mitigation through Dynamic Control of Runway Configurations and of Arrival and Departure Service Rates under Stochastic Operating Conditions,” *ESD Working Paper Series*, Available at <http://esd.mit.edu/WPS/2013/esd-wp-2013-14.pdf>, 2013.
- [51] D. Bertsimas, G. Lulli, and A. Odoni, “An Integer Optimization Approach to Large-Scale Air Traffic Flow Management,” *Operations Research*, vol. 59, no. 1, pp. 211–227, 2011.
- [52] H. Balakrishnan and B. Chandran, “Algorithms for Scheduling Runway Operations Under Constrained Position Shifting,” *Operations Research*, vol. 58, no. 6, pp. 1650–1665, 2010.
- [53] C. Barnhart, D. Bertsimas, C. Caramanis, and D. Fearing, “Equitable and Efficient Coordination in Traffic Flow Management,” *Transportation Science*, vol. 46, no. 2, pp. 262–280, 2012.
- [54] O. de Weck, D. Roos, and C. Magee, *Engineering Systems: Meeting Human Needs in a Complex Technological World*. The MIT Press, 2011.
- [55] A. Barnett, *The Global Airline Industry*. John Wiley & Sons Ltd., 2009, ch. Aviation Safety and Security, pp. 19–46.
- [56] V. Sakhrani, “A Post Hoc Valuation Study of Delhi’s Indira Gandhi International Airport,” 2014, working Paper, MIT.
- [57] A. Jacquillat and I. Simaiakis, “Capacity Expansion vs. Schedule Coordination: Ex Post Assessment of the Construction of a New Runway at Charlotte International Airport,” 2014, working Paper, MIT.
- [58] Airport Commission, “Interim report,” Tech. Rep., 2013.
- [59] Office of Inspector General, “New York Flight Delays Have Three Main Causes, but More Work Is Needed To Understand Their Nationwide Effect,” U.S. Department of Transportation, Tech. Rep. AV-2011-007, 2010.
- [60] Government Accountability Office, “Slot-Controlled Airports: FAA’s Rules Could be Improved to Enhance Competition and Use of Available Capacity,” Tech. Rep. GAO-12-902, 2012.
- [61] A. Jacquillat and A. Odoni, “Congestion Mitigation through Schedule Coordination at JFK: An Integrated Approach,” *ESD Working Paper Series*, Available at <http://esd.mit.edu/WPS/2013/esd-wp-2013-17.pdf>, 2013.