

FOREST FUTURES

by Sean Phillips

B.A. Architecture
University of California Berkeley, 2012

Submitted to the Department of Architecture
in partial fulfillment of the requirements for the degree of
Master of Architecture at the Massachusetts Institute of Technology

February 2018

© 2018 Sean Phillips. All rights reserved.

The author hereby grants to MIT permission to reproduce and to distribute publicly paper and electronic copies of this thesis document in whole or in part in any medium known or hereafter created.

SIGNATURE OF AUTHOR:

Massachusetts Institute of Technology
January 18, 2018

CERTIFIED BY:

Rania Ghosn
Assistant Professor of Architecture and Urbanism
Thesis Supervisor

ACCEPTED BY:

Sheila Kennedy
Professor of Architecture
Chair of the Department Committee on Graduate Students

Forest Futures

COMMITTEE

Rania Ghosn, DDes
Assistant Professor of Architecture and Urbanism, MIT
Advisor

Sheila Kennedy, MArch
Professor of Architecture, MIT
Reader

Sonja Dümpelmann, MLA, PhD
Associate Professor of Landscape Architecture, Harvard GSD
Reader

Forest Futures

BY SEAN PHILLIPS

Submitted to the Department of Architecture
on January 18th, 2018 in partial fulfillment of the requirements for the
Degree of Master of Architecture at the Massachusetts Institute of Technology

ABSTRACT

With recent interest in carbon emissions, wood has returned as a fashionable building material. Renewable, flexible, and a carbon sink, wood is increasingly seen as a material that responds to concerns of climate change. However, an acceptance of the Anthropocene demands a re-thinking of how humans relate to natural systems, and this thesis argues that with a return to wood, architecture must also return to its source - the forest - for inspiration and sites of intervention.

This thesis sites itself within Mendocino National Forest in northern California. As sites of both extraction and conservation, National Forests are messy landscapes often overlooked in favor of their more manicured cousins, National Parks. National Forests are also under threat. Political hostility towards public land, drought, and wildfire threaten northern Californian forests more than ever before.

2017 – like 2015, 2012, 2006, and 2002 – has been the worst year on record for wildfire in California. National Forest budgets are increasingly consumed by fire suppression and – fueled by a changing climate and poor management - dangerous wildfires are the new normal for California.

Fire, the great destroyer, is also a valuable ecosystem actor. Forest (and Californian)

futures will depend on looking beyond the crisis of fire for opportunities within the fire cycle. This project proposes ‘forest futures’ in three chapters, each located at a point within the northern Californian mixed-conifer fire cycle - fighting fire, after the burn, and working with fire.

Mendocino National Forest, even as the least visited in California, is filled with overlapping human and non-human worlds. Each chapter proposes an architectural intervention that engages the world of a forest dweller and their forest – the Conservation Tower, Burnout Lodge, and the Yule Tree Farm.

Advisor: Rania Ghosn
Assistant Professor of Architecture and
Urbanism

acknowledgements

I would like to sincerely thank the faculty and fellow students who I was able to learn from and work alongside over these last 4 years.

To my advisor, Rania, thank you for your patience and the time you generously gave to the project. Your insight and enthusiasm opened up many new directions for exploration and kept me pushing for more.

To my readers Sheila Kennedy and Sonja Dümpelmann, thank your generosity and advice. Your insights helped me clarify my enthusiasm into more than a mess of ideas.

To my friends and colleagues, thank you Hugh, Sam, Sergio, Roi, Tyler, Zach for your time and perspective. Thank you Steph for your help during the final push. Monica, thank you for your encouragement and patiently listening to my excitement and anxieties over the semester.

Finally, thanks to my parents for continuing to support me after all these years.

contents

ABSTRACT	5
ACKNOWLEDGEMENTS	7
INTRODUCTION The Word for World is Forest	11
MENDOCINO NATIONAL FOREST	20
I FIGHTING FIRE National Forest policy and the ‘Conservation Tower’	26
II SCAVENGING IN THE AFTERBURN Salvage Ecologies and the ‘Burnout Lodge’	52
III RITUALS OF PRODUCTION ‘Yule Log Farm’ A Christmas tree plantation for the Bay Area	80
APPENDIX A Thesis Defense	110
APPENDIX B Mendocino Conservation Towers	116
APPENDIX C Research and Maps	128
BIBLIOGRAPHY	140

**...the substance of their
world was not earth,
but forest...**

Ursula K. Le Guin
The Word for World is Forest

The Word for World is Forest

INTRODUCTION

In early October 2017, California saw a series of the most destructive wildfires in its history. Fueled by high winds, a wet winter, and a very dry summer, the Tubbs fire alone burned more than 5,100 structures and killed 22 people outside of Santa Rosa. After the worst wildfire season in California's history, many scientists have argued that this is the "new normal" – that climate change induced disasters such as the Tubbs complex fire will become the even more frequent.

There is more to the story of fire in northern California than the influence of atmospheric carbon. On the fire lines in October were thousands of inmates, some from the nearby Mendocino National Forest. Much of the 2x4

dimensional lumber that the ranch houses were constructed out of came from those very forests. And one of the reasons that fires have become more destructive of late is not because there are more fires, but that Californian cities have continued to sprawl into the wildland-urban interface. The Tubbs fire and the story of fire in northern California is convergence of ecology, politics, economy, and architecture.

Since the 1970's there have been various calls for "environmental," "ecological," "sustainable," and "green" architectures. Despite the variety of word-play, these architectural modes share the same approach. They focus on the same material and energy flows while often ignoring

**This was the order of
human institutions:
first the forests, after
that the huts, then
the villages, next the
cities, and finally the
academies.**

Giambattista Vico
The New Science

the many other threads that tie environment to architecture. Most of those houses in Santa Rosa had solar panels on the roof. But they were also constructed by the myth of the American dream, designed without thinking of fire, built with standardized wood dimensions, and protected by the labor of the incarcerated.

This thesis aims to reengage architecture with the environment by telling environmental stories that interweave architecture, ecology, economy, and politics. It aims to expand the material story of environmental architecture into human stories and, eventually, give way to what Donna Haraway calls “geo-stories.” If architecture has any role to play in environmental futures, it is in not only in designing material and energy flows, but in recrafting the stories of how humans and the environment create worlds together.

This thesis uses the forest as a site for an environmental architecture. Forests are not only the source of important raw materials for architecture, but also have a rich legacy of human-non-human interaction. From founding myths to fairy tales, forests are home to countless stories pitting human against non-human, and are what Giambattista Vico called the earliest human institution.

National forests are chosen as a site because, as sites of both extraction and conservation, they are a messy emblem of the Anthropocene. Forestry management is also at the heart of environmental debate. State forests are where the concepts of

sustainability, conservation, and wilderness were originally developed, and where debates about conservation versus production continue to play out.

Thinking through fire in the national forests of Northern California, ‘Forest Futures’ projects new stories of architecture-environment engagement. Instead of approaching forest fires as a problem to be solved, and run the risk of “falling prey to extreme pragmatism and neo-environmentalist do-goodism,” this project explores architecture’s ability to imagine new architecture-environment scenarios, and to expose the multiple worlds already existing within California’s forests.

Thinking with the forest can be a source for ecological ethics for these times we’re calling the Anthropocene

Eduardo Kohn
The New Science

WOOD

With recent interest in carbon, wood has returned as a fashionable building material. Renewable, flexible, and a carbon sink, wood is seen as the material that best responds to climate change. Wood's versatility and unique material properties have recently led architects to push for specifying wood and new wood products for everything from heating fuel to the structure of skyscrapers. The more attentive architects also realize that wood species specification is an important design consideration with forest landscape implications. However, an acceptance that humans have touched every corner of the earth demands more from architecture than thinking through material sourcing. Viewing forests solely through the material lens misses opportunities for discovering ecologies with new shades of green.

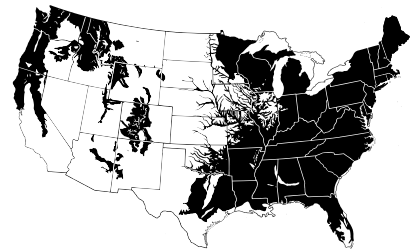

Virgin Forest Cover 1620

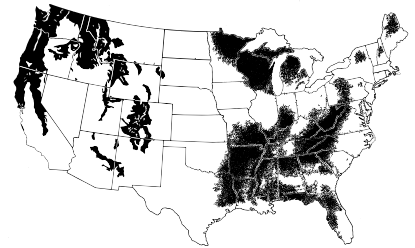

Virgin Forest Cover 1850

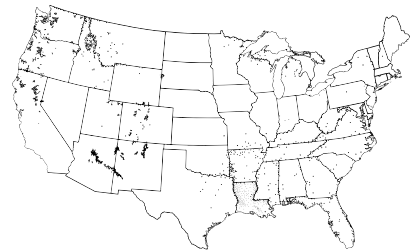

Virgin Forest Cover 1926

US National Forest System 1891 - 2018

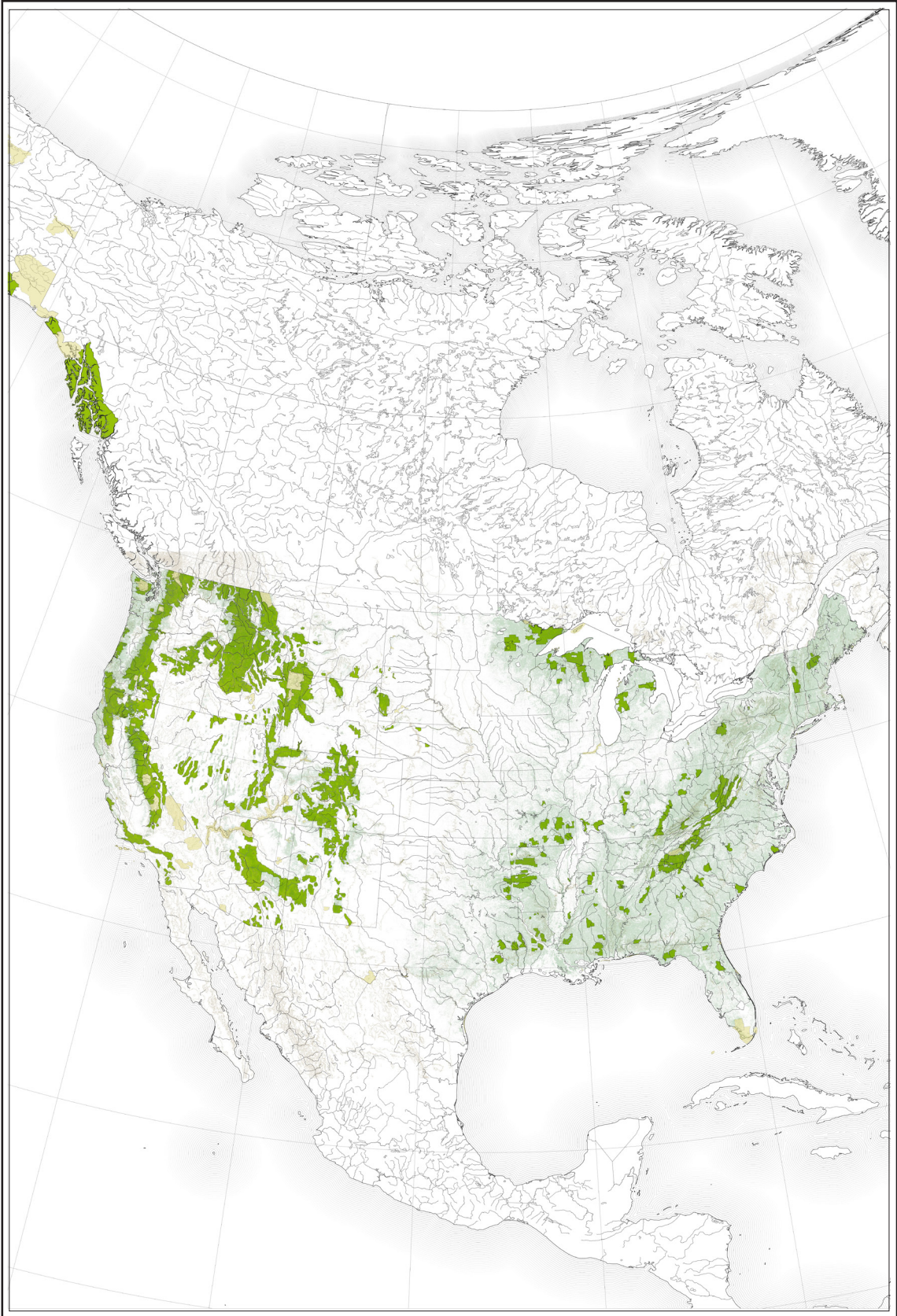

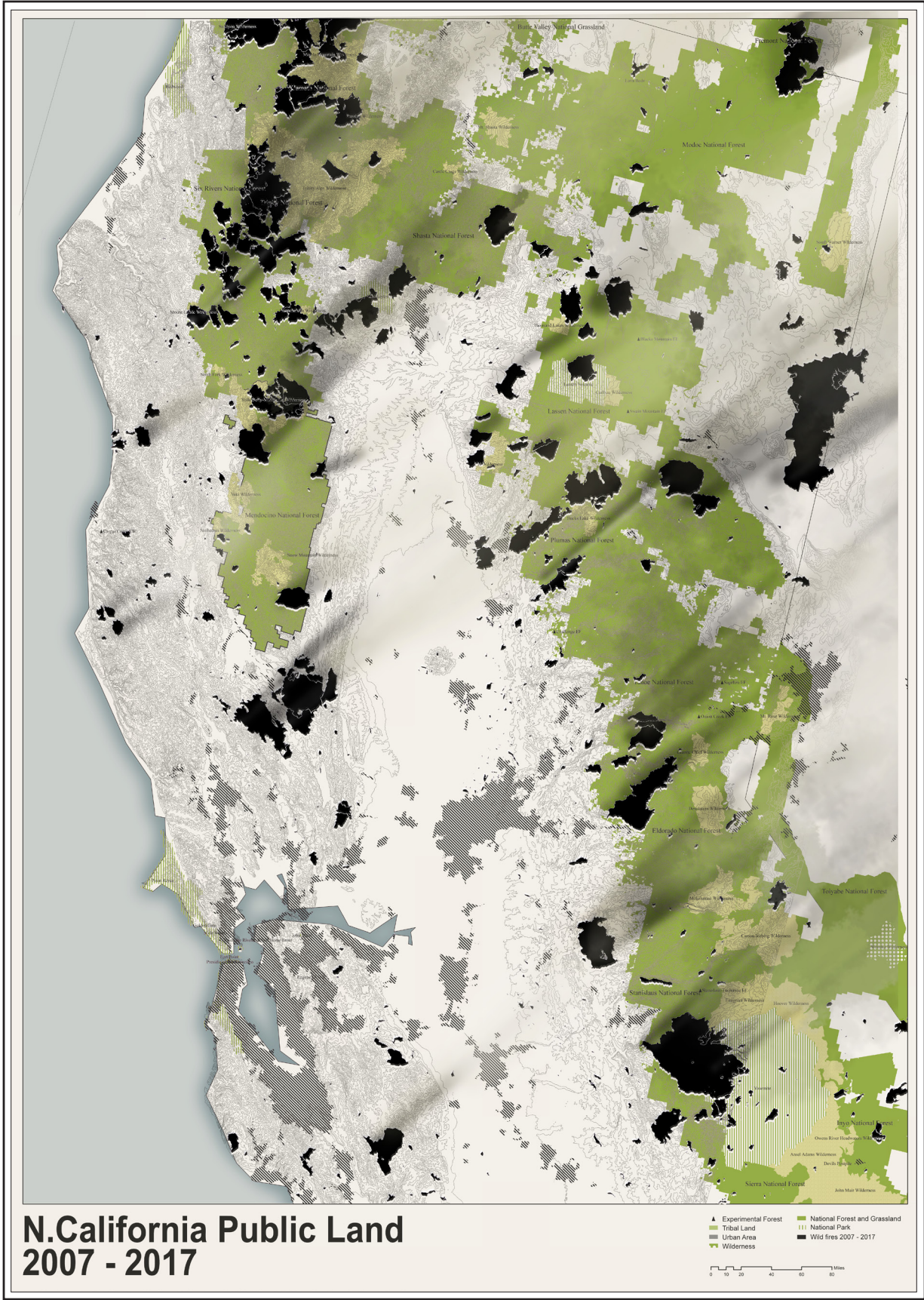

FORESTS

As sites of both extraction and conservation, National Forests are messy landscapes often overlooked in favor of their more manicured cousins, National Parks. Recently, National Forests in the West have struggled to manage their lands. For decades, timber sales have cost forests more than they make. Political apathy towards federally owned public land has raised the real possibility of sell-offs to private hands. Finally, the most visible manifestation of the forest's struggles has been the increasingly difficulty of fighting forest fires. And while the solutions to many of these problems lie within the realm of politics and ecology, architecture, as a project of world making, can begin to propose new futures.

Tools and Techniques of the National Forest System

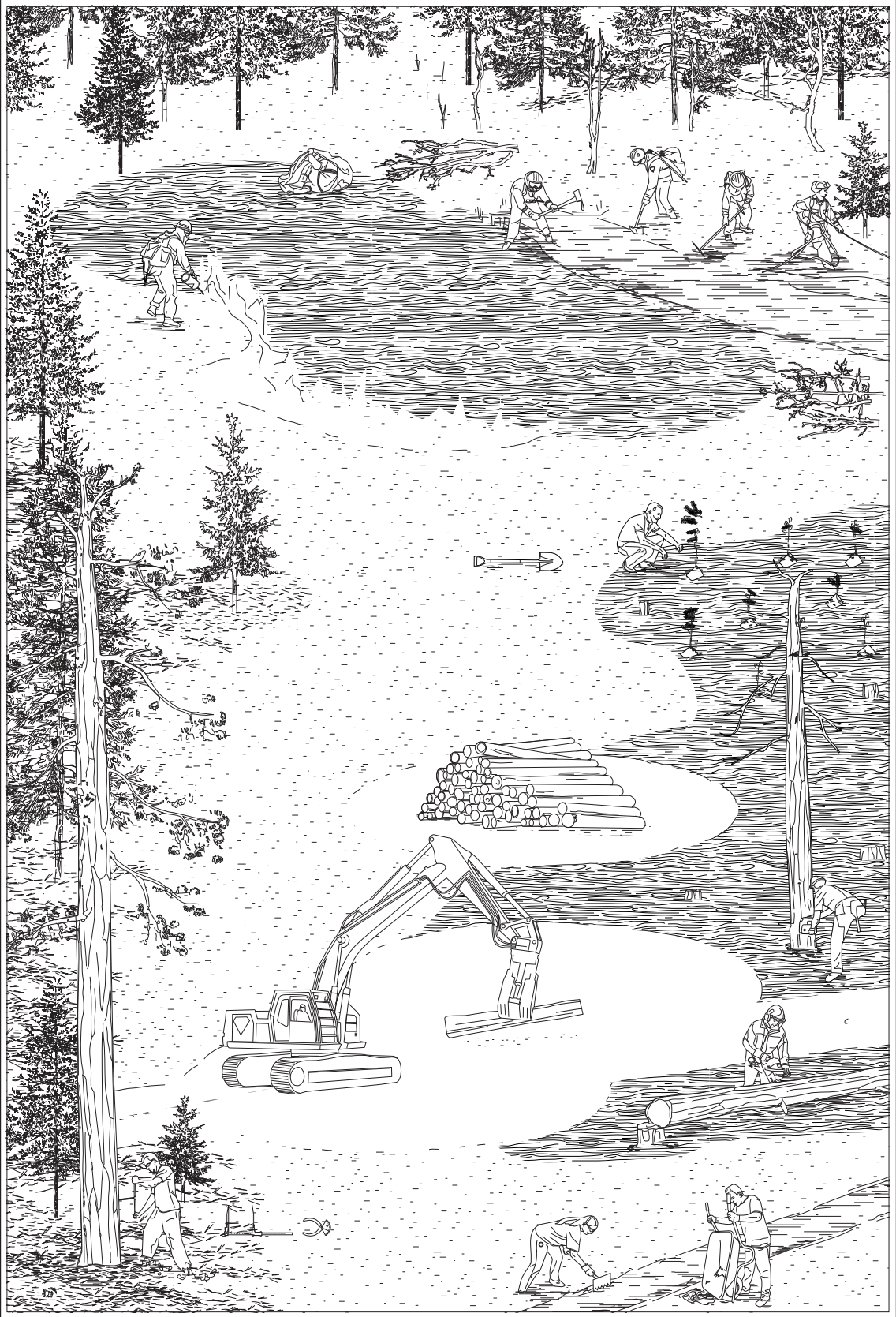

FUTURES

This thesis proposes new 'forest futures' drawn through architectural interventions that engage more than the material of the forest (wood). 'Green' narratives and 'sustainable architecture' should be more than material flow diagrams. Dark politics, pagan rituals, mushrooms, and fire play an equal role to the many forms of wood in the story of Mendocino National Forest.

In asking what a forest future looks like, this project has leaned on the image of the porcupine - looking ahead while backing under a crevice.¹ Much like the fire cycle within which this project is sited, the future is cyclical - always changing, but returning to what was. A forest.

1. In her "A Non-Euclidean View of California as a Cold Place to Be" Ursula K. Le Guin recounts the Native American story of the porcupine. "The opening formula for a Cree story is 'an invitation to listen, followed by the phrase 'I go backward, look forward, as the porcupine does.' In order to speculate safely on an inhabitable future, perhaps we would do well to find a rock crevice and go backward." Seeking to subvert the idea of utopia as a "one-way future consisting only of growth," Le Guin follows the model of the porcupine in speculating on Western futures. Inspired by the writings of Le Guin and her cyclical narratives, 'Forest Futures' looks for futures which already exist or are going to have existed in Californian forests.

Mendocino National Forest

AN EXPERIMENTAL FOREST IN THREE PARTS

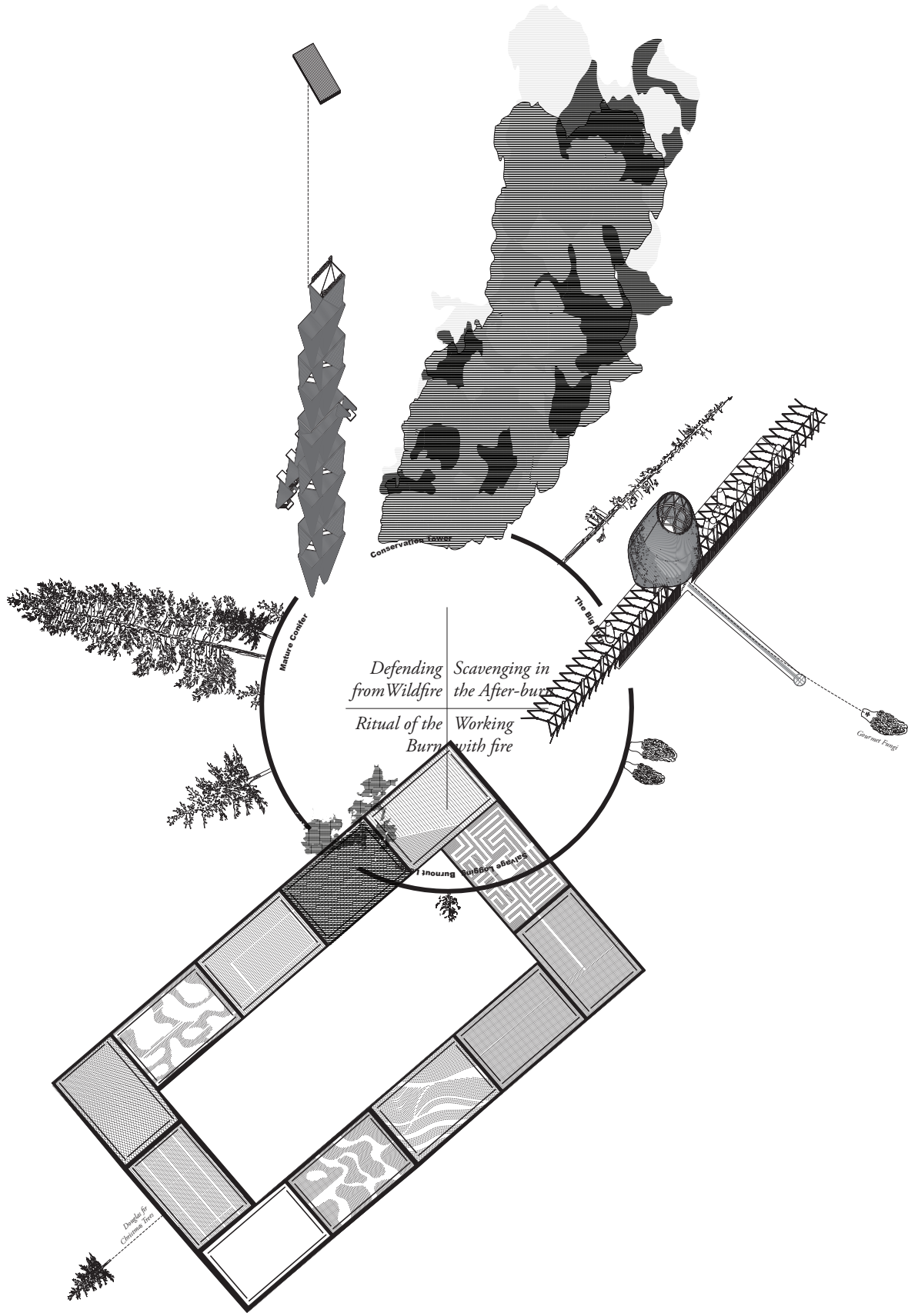

Forest Futures

DESIGNING WITH THE FIRE CYCLE

Forest Futures is an experimental forest for Mendocino National Forest. Mendocino National Forest is the southernmost forest in the western band of National Forests stretching from Canada to Northern California. While only three hours from San Francisco and Sacramento, Mendocino is the least visited forest in California, primarily because of limited road access. The proposal is for a set of 3 interventions designed within the fire cycle, engaging the ongoing world making projects within the forest.

The project is sited in the context of new economic pressures and escalating environmental challenges facing the forest. This project argues that fire is not only a crisis, but that there are opportunities to design within fire cycle. The three interventions are sited at different points of the fire cycle. One fights against wildfire. One scavenges after the big burn. And one is a new forest designed with fire and the extraction cycle in mind.

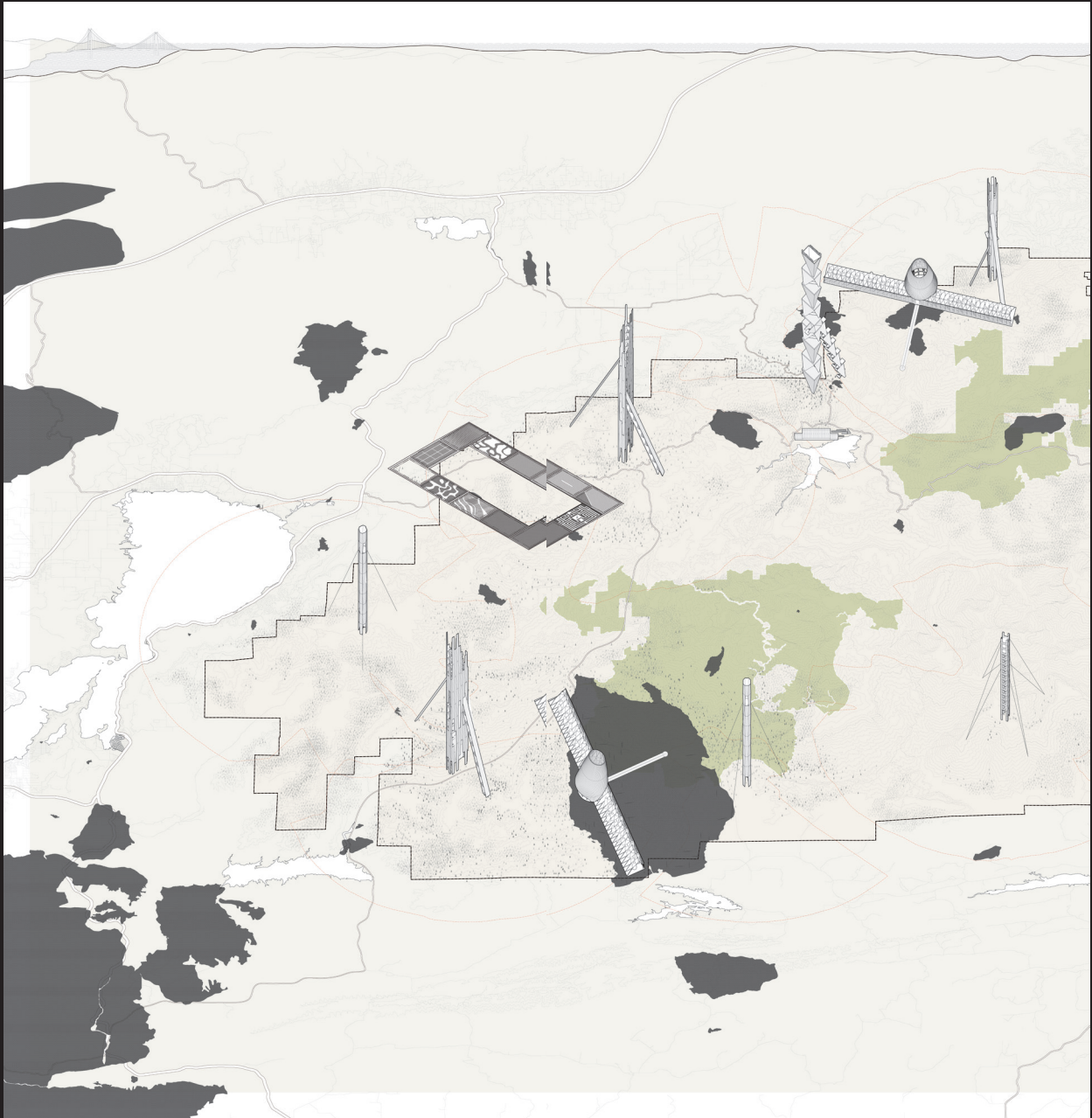

MENDOCINO NATIONAL FOREST

Three interventions in the fire cycle

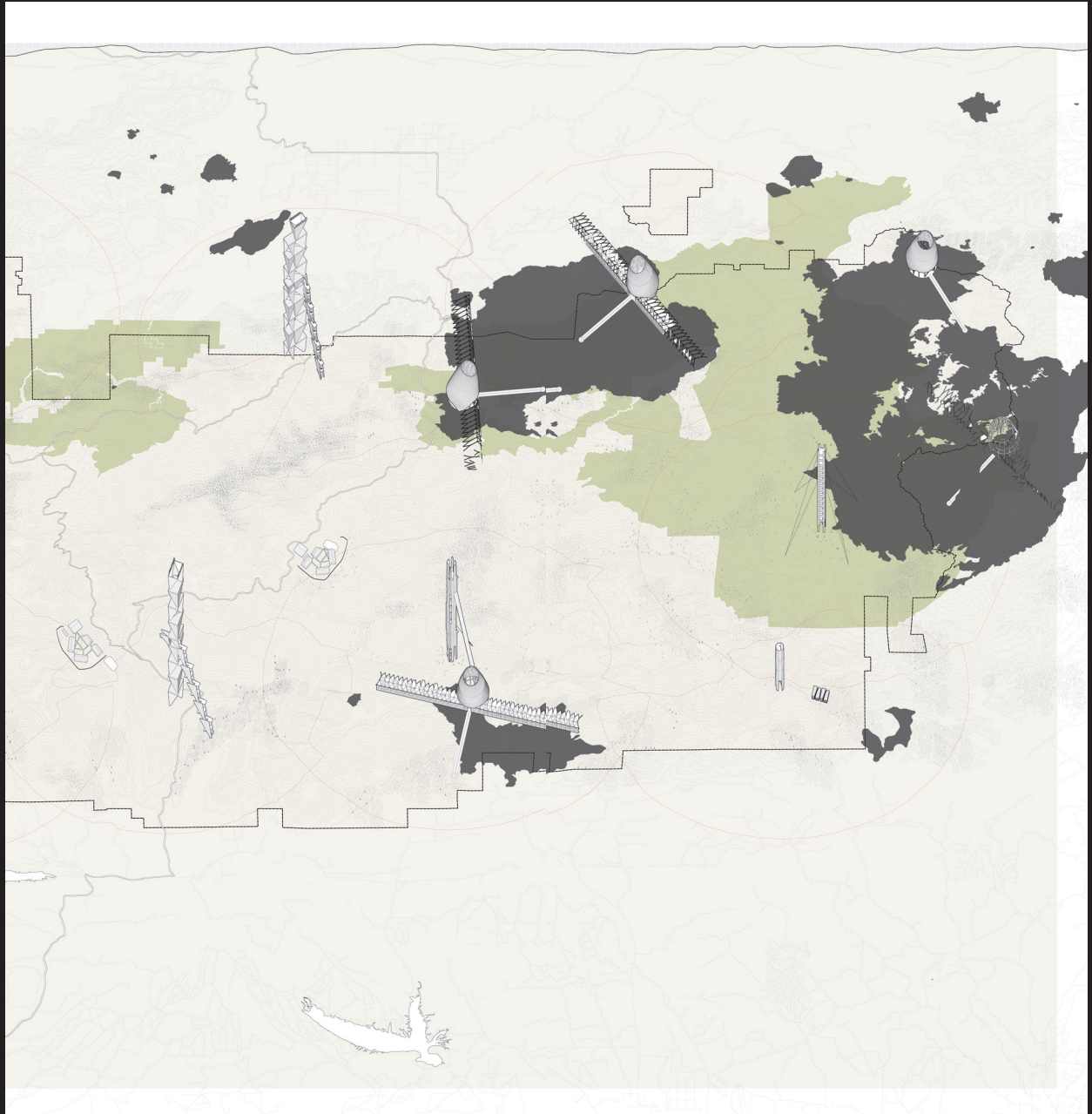



Fighting Fire

NATIONAL FOREST FIRE POLICY AND THE 'CONSERVATION TOWER'

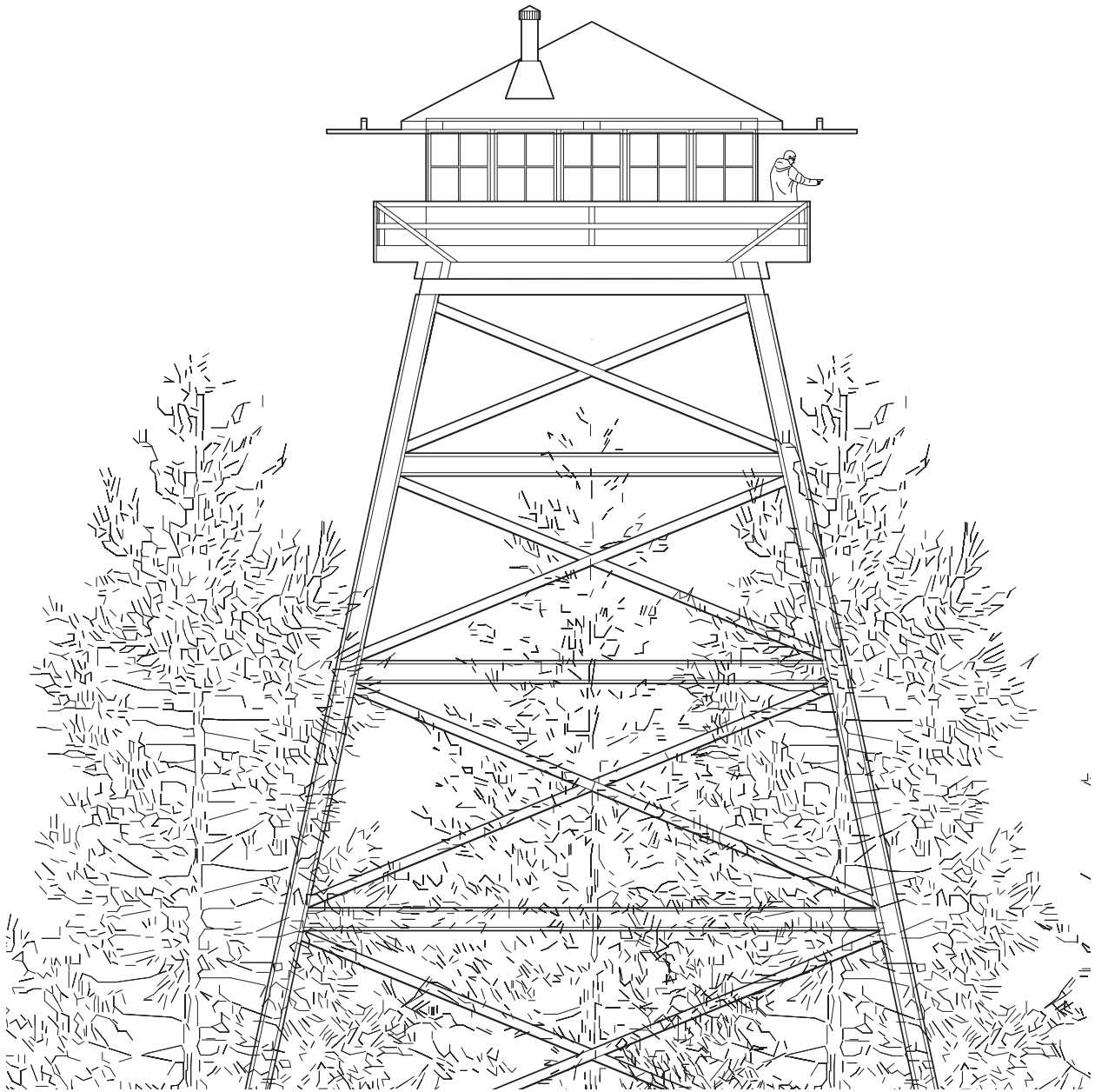

Since its founding, the US Forest Service has seen fighting forest fires as a primary part of their mission. Two of the main tools in fighting fires have been the fire watch tower and the fire line. The watch tower - once a prominent feature of American forests - was an inhabited lookout tower and has largely been replaced by remote sensing technology.



The fire line - perimeter break in fire fuel used to contain fires - is still in use, and are still largely cut by hand. In California, much of this labor is done by inmates.

California relies on the labor of 4100 inmate fire fighters. 40% of California's back country fire fighters are non violent prisoners. Mendocino National Forest currently contains two "Conservation Camps."

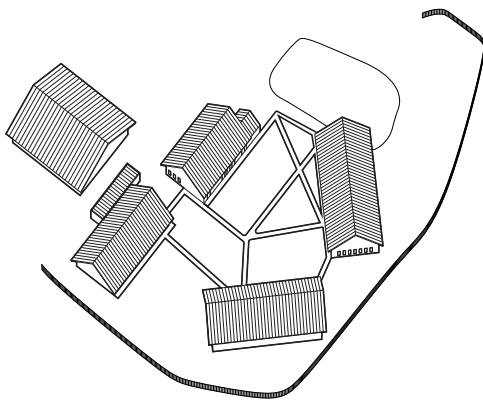

Salt Creek Conservation Camp

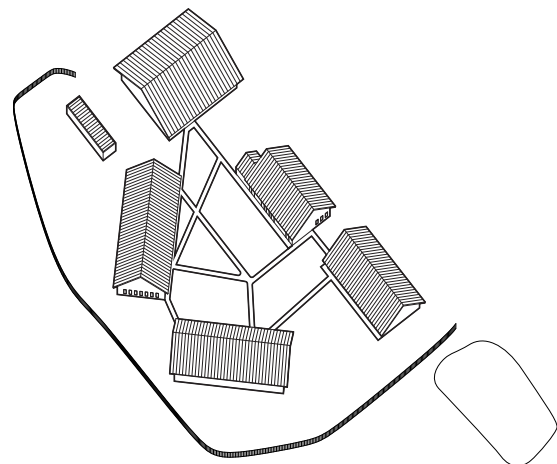

Valley View Conservation Camp

Salt Creek and Valley View Conservation Camps are located deep within the Mendocino National Forest and each house 130 prisoners and 20 civilians.

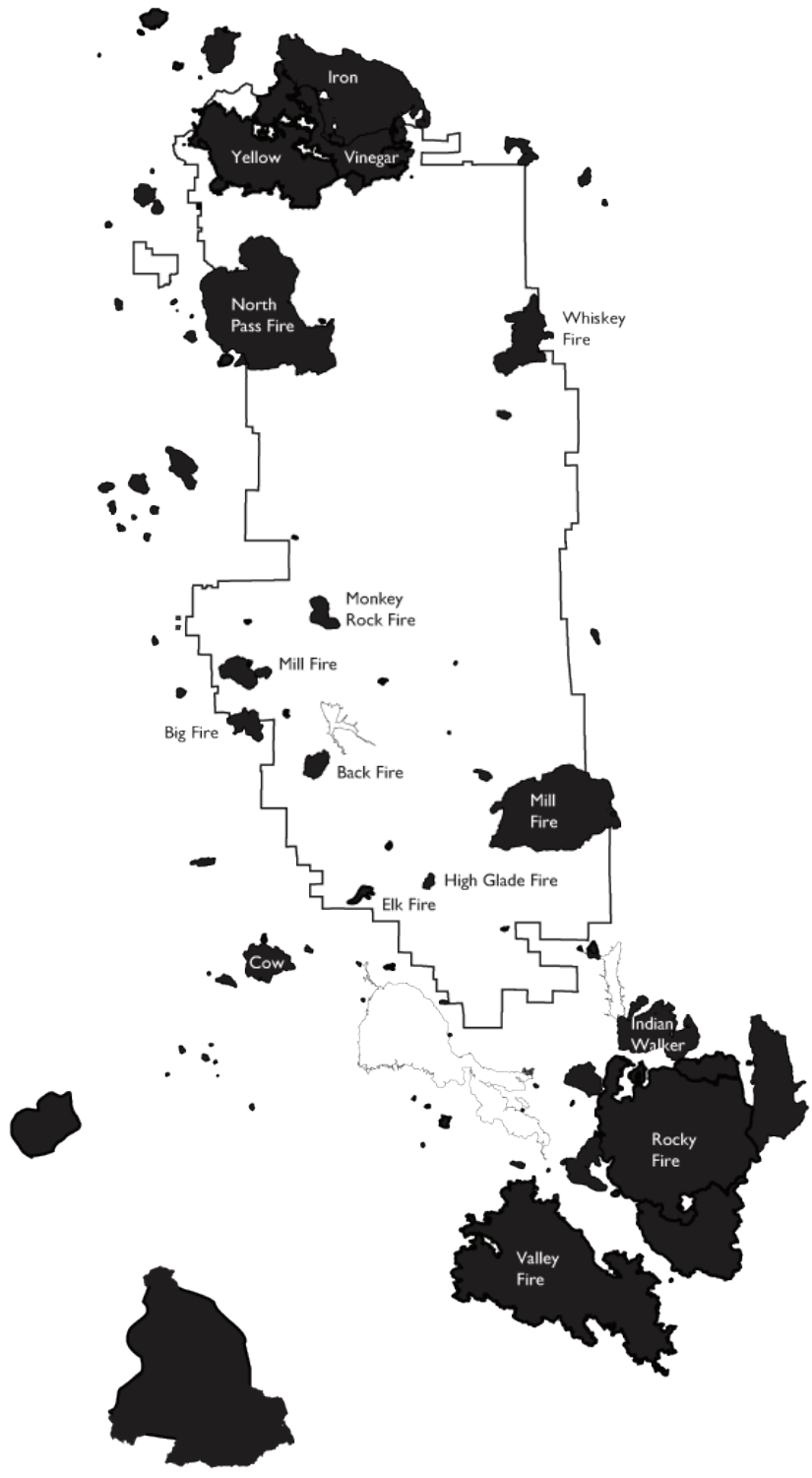

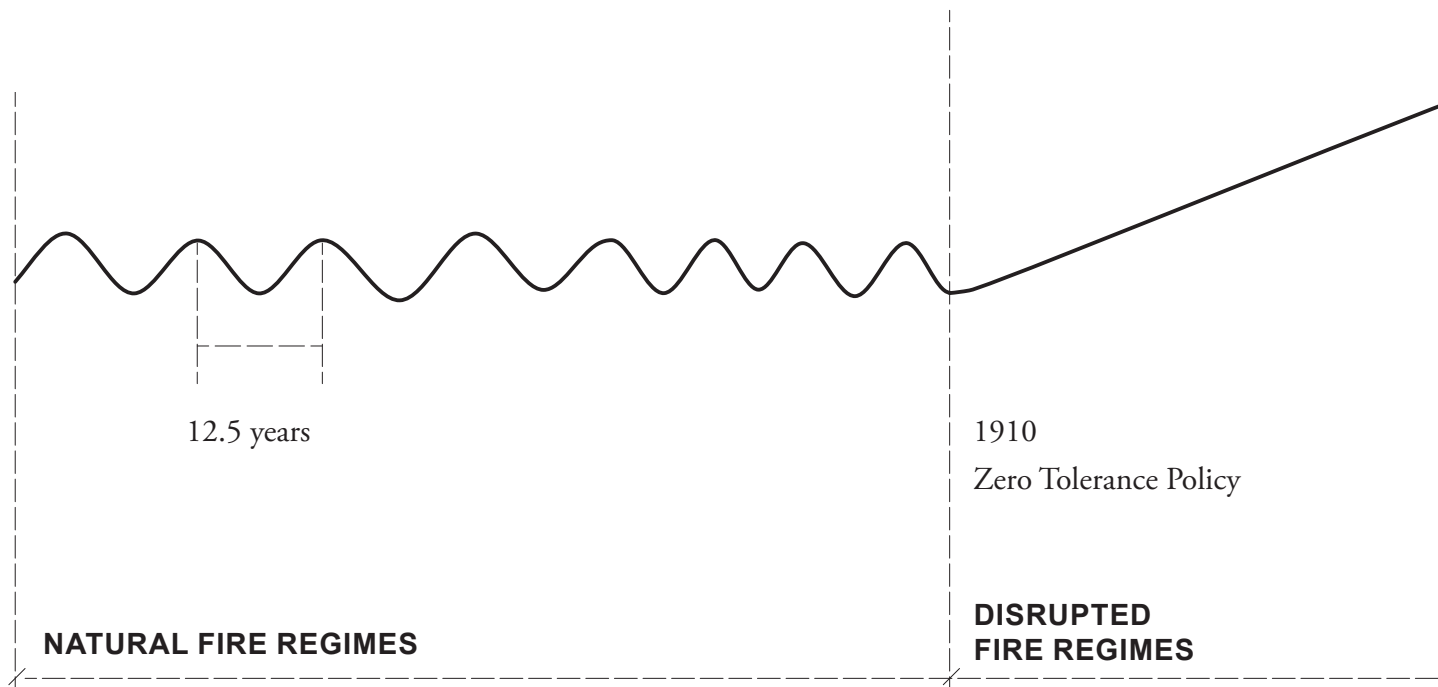

When the National Forest Service implemented their fire suppression strategies, they disrupted natural fire cycles. Dangerous amounts of fuel have built up in most of America's forests because frequent low-intensity burning has been stopped. This poor management, combined with climate change induced moisture changes, have created dramatically dangerous fire conditions in the West.

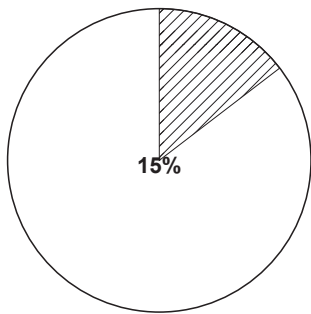
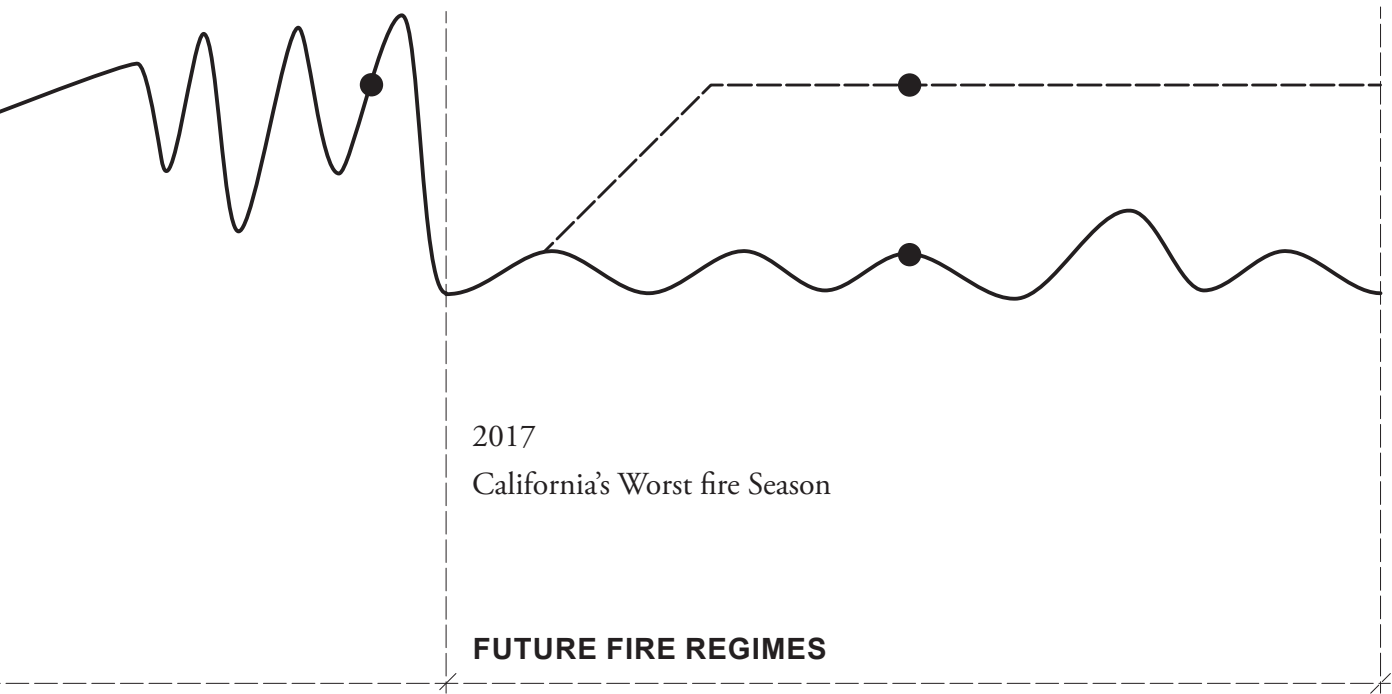

1995

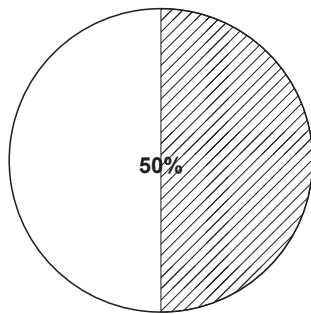

2015

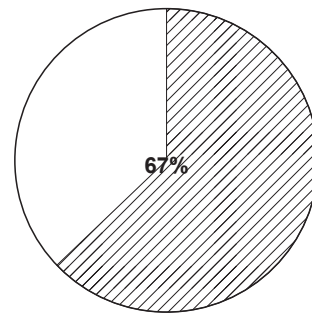

2025

NATIONAL FOREST FIRE SUPPRESSION BUDGET

The National Forest projects that as soon as 2025, two-thirds of their budget will be spent fighting fire, at the expense of other forest projects, including fire prevention. Based on this 'new normal' fire climate and California's dependence on cheap inmate labor, an increase in the inmate prisoner population is all but inevitable.

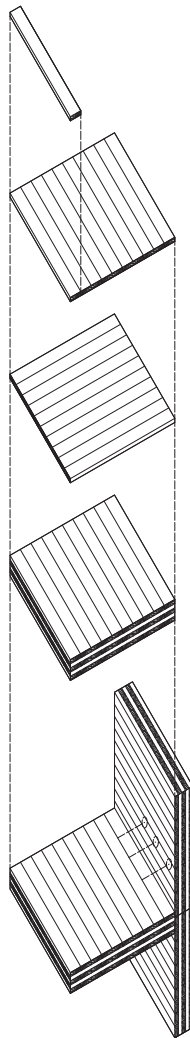

CLT Construction

On the other hand, the Forest Service is attempting to engage private companies in fuel removal, and championing Cross-Laminated Timber (CLT) as a sustainable way to utilize low value timber. One of the technologies the Forest Service's Product Laboratory is promoting is Tall Timber constructed from CLT.

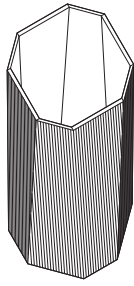

Typology 1 - Trunk

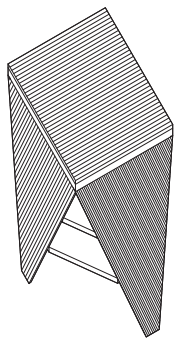

Typology 2 - Tent

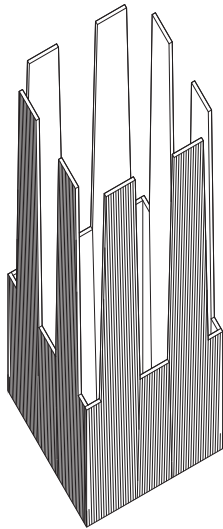

Typology 3 - Bark

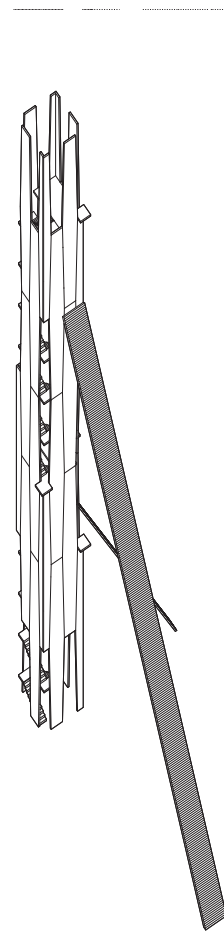

Back-country stability

Growing the Tower

Canopy Access

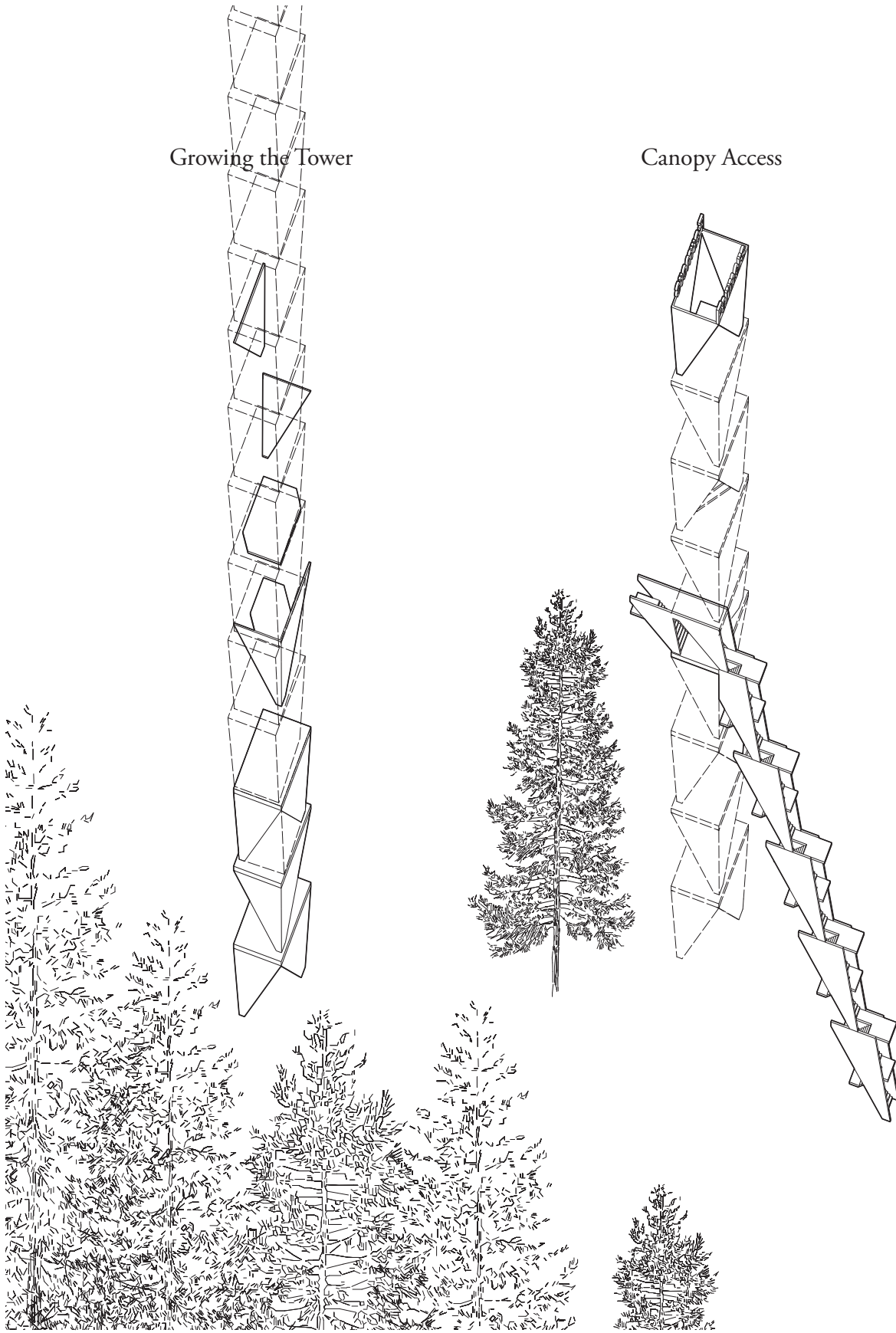

The Conservation Tower revives the ghost of the fire tower as a series CLT Tall Timber types. Constructed from pre-fabricated timber panels and with minimal foundations.

Collective 10-Inmate Unit

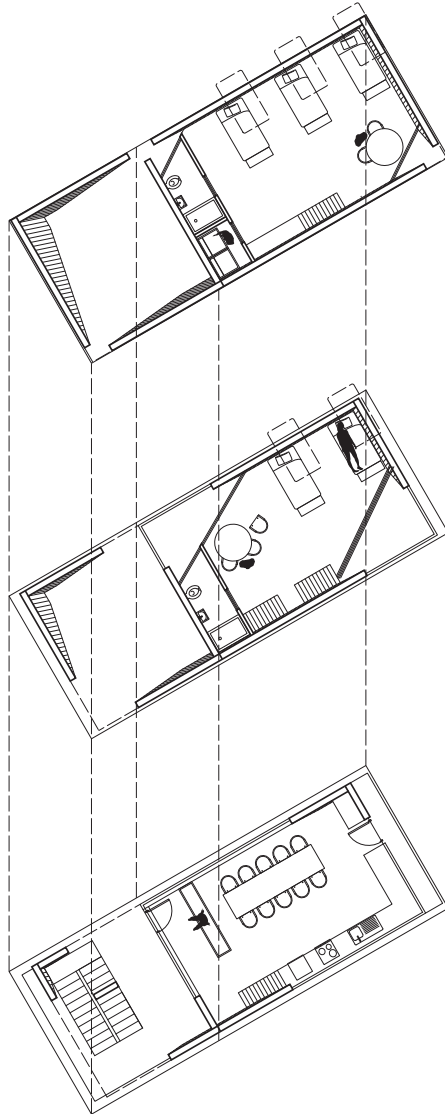

Once above the canopy, they house the growing inmate population in new, collectivized housing units.

The new Conservation Towers grow along with inmate population.

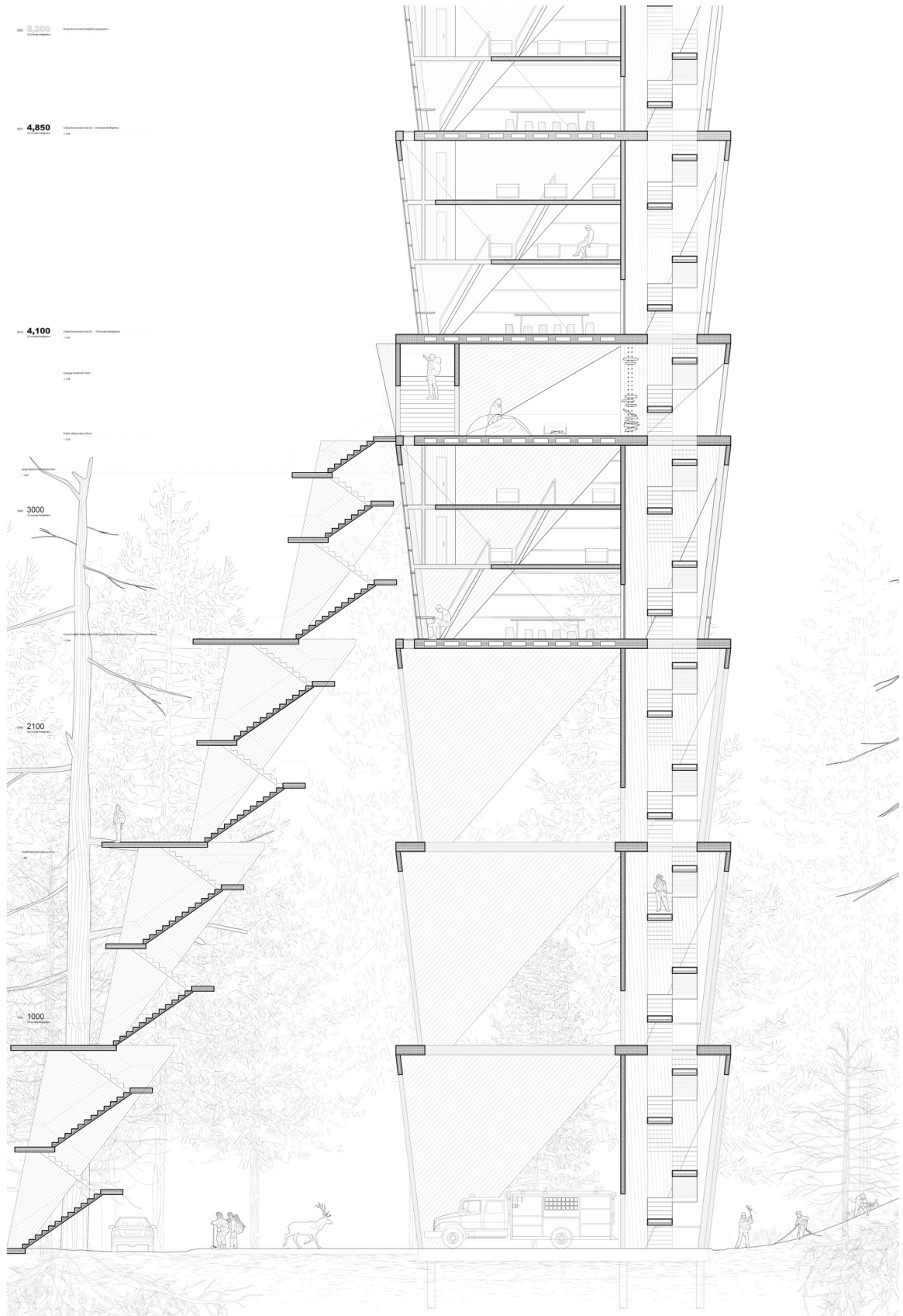

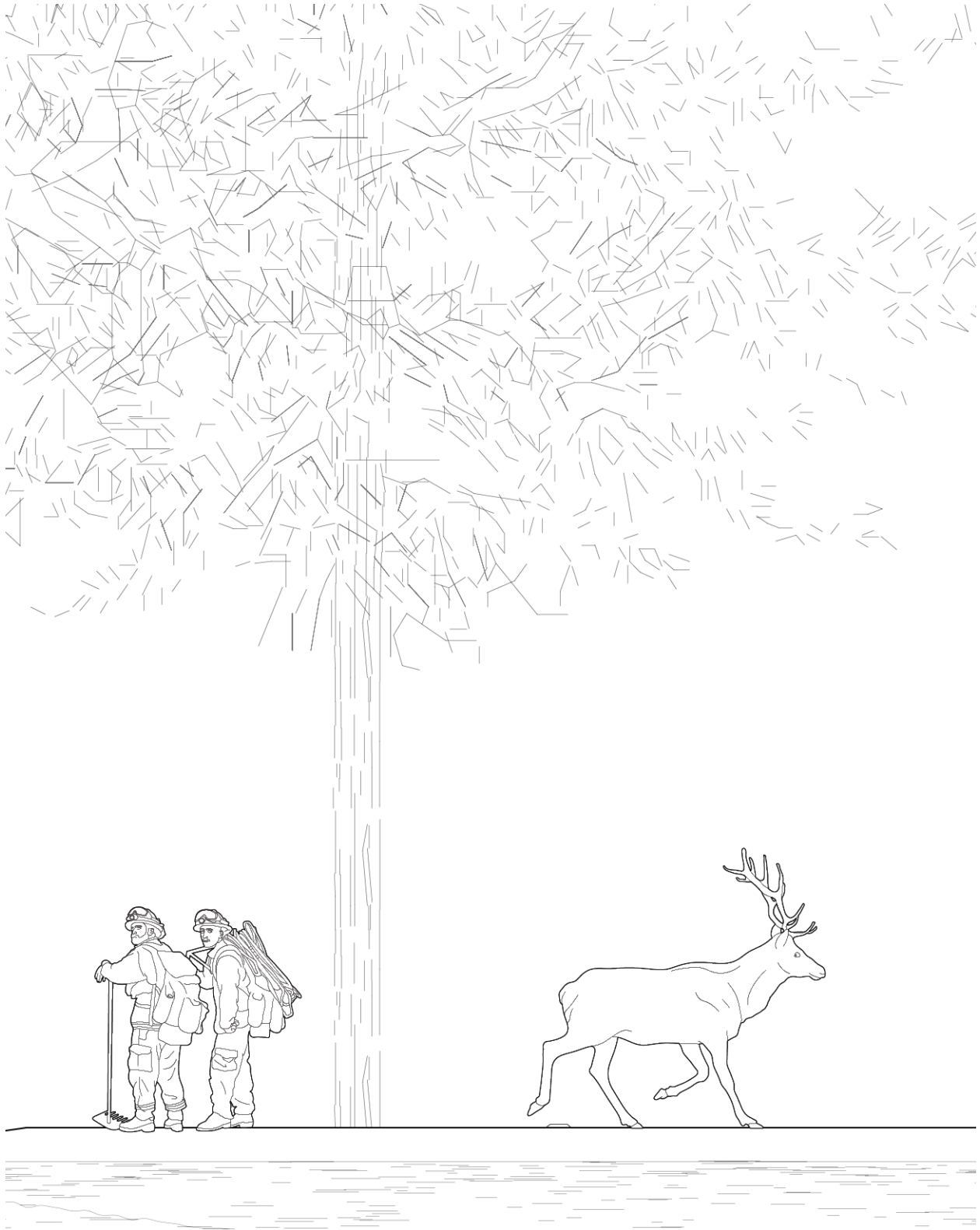

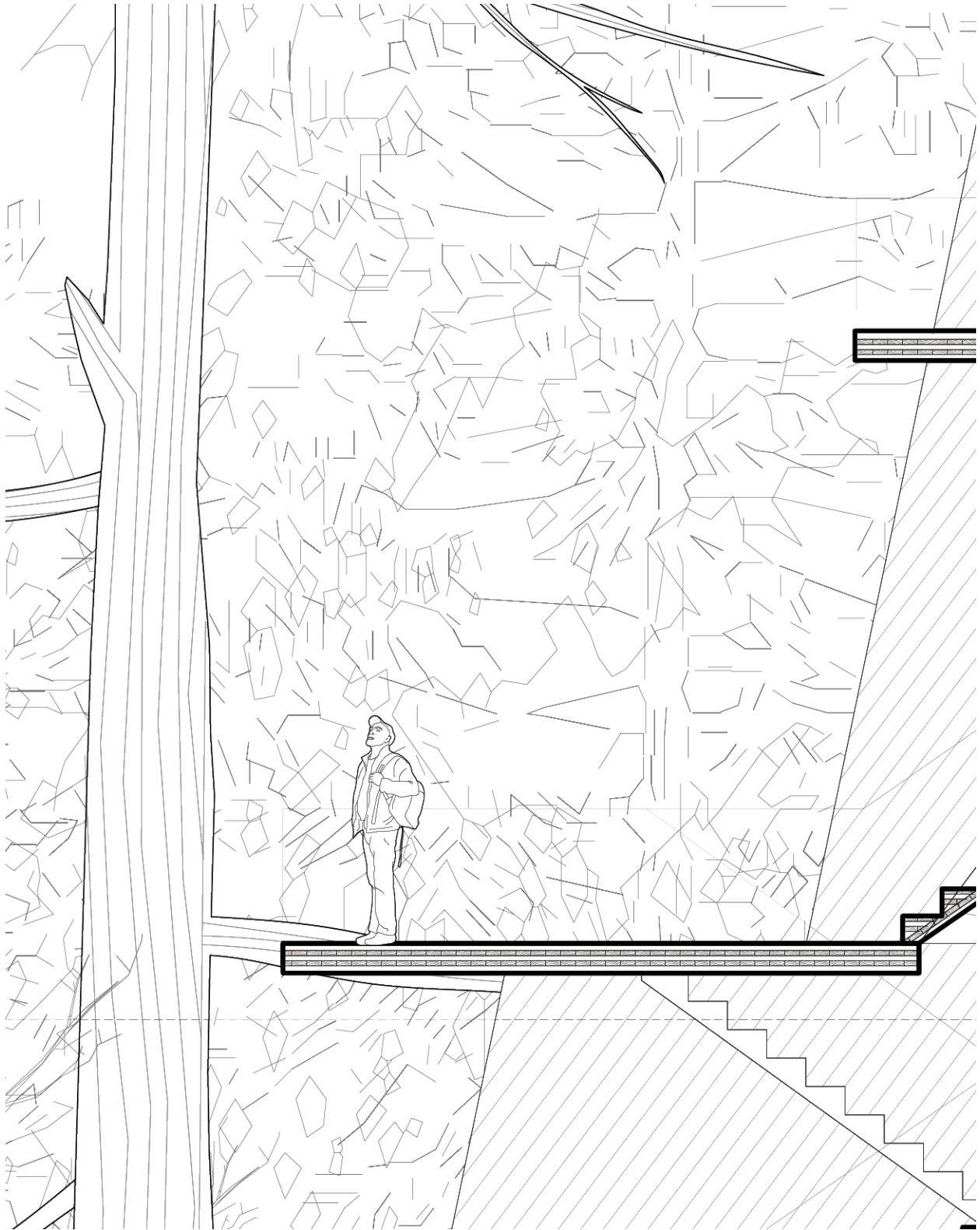

The largest towers, placed along main access roads, form new gateways to the forest and use their height to provide publicly accessible observation canopy observation decks.

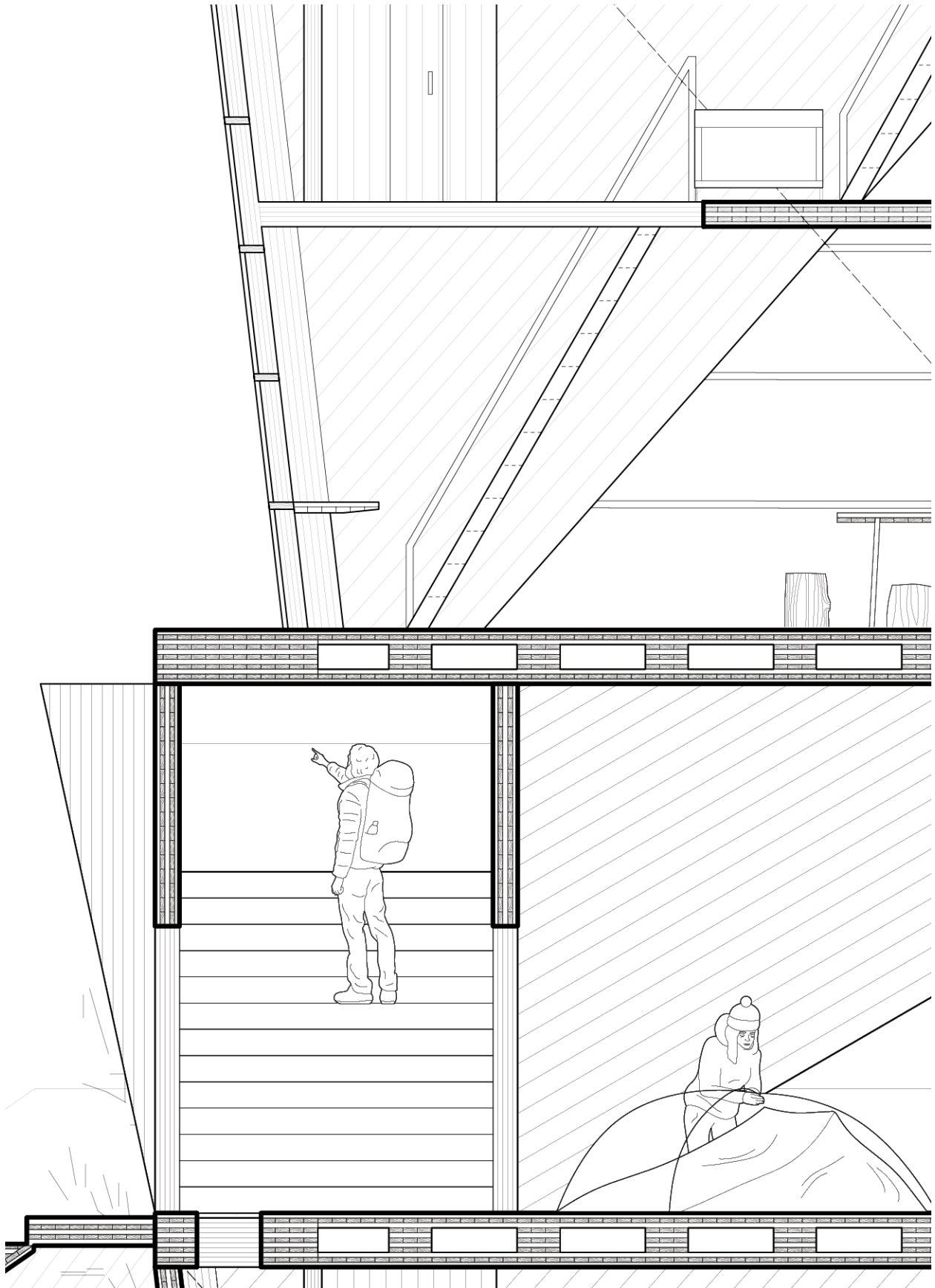

The public observation decks provide new opportunities for inmate-civilian interaction.

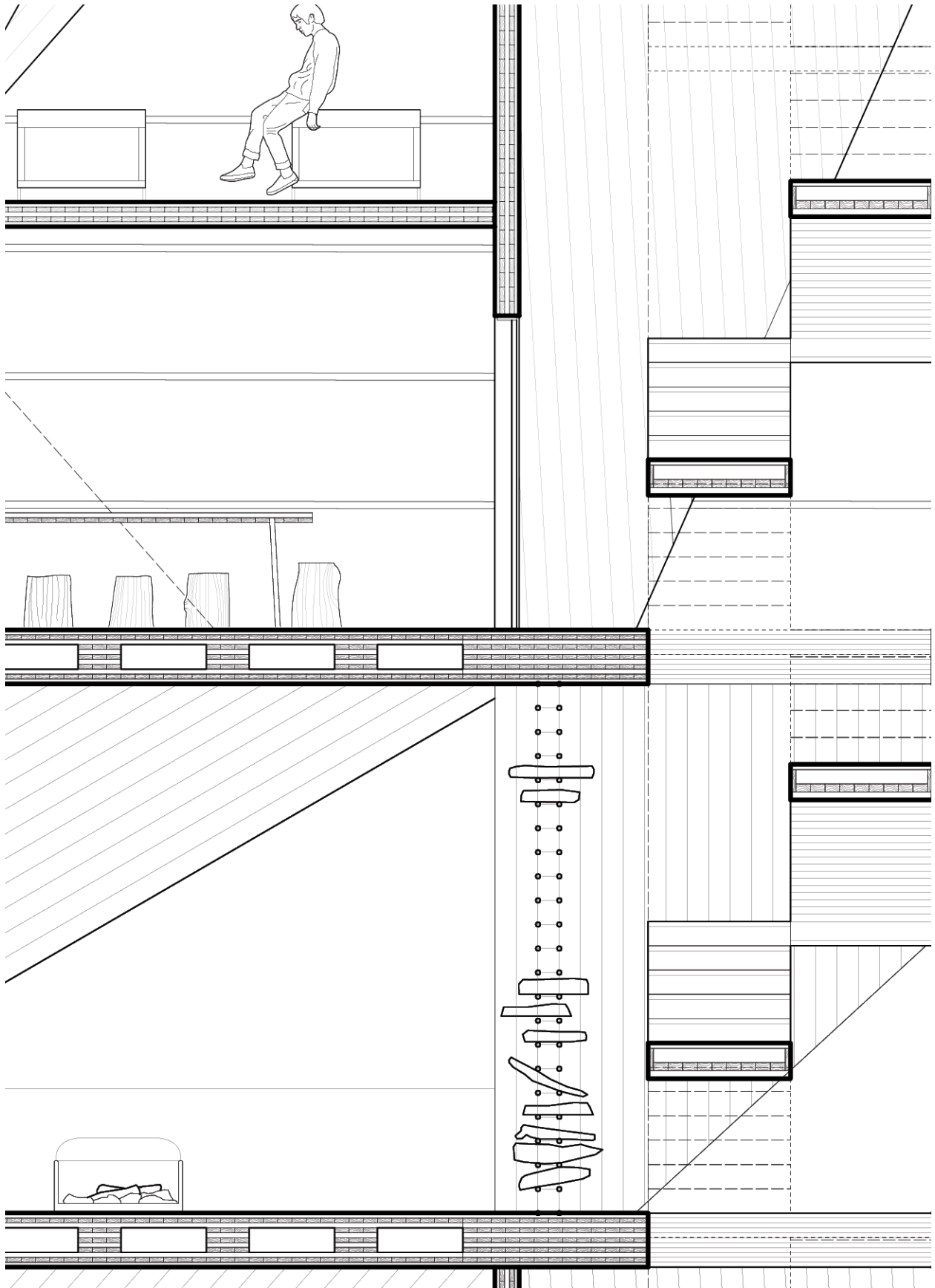

A fire wood wall separates the civilian observation deck from the prisoners.

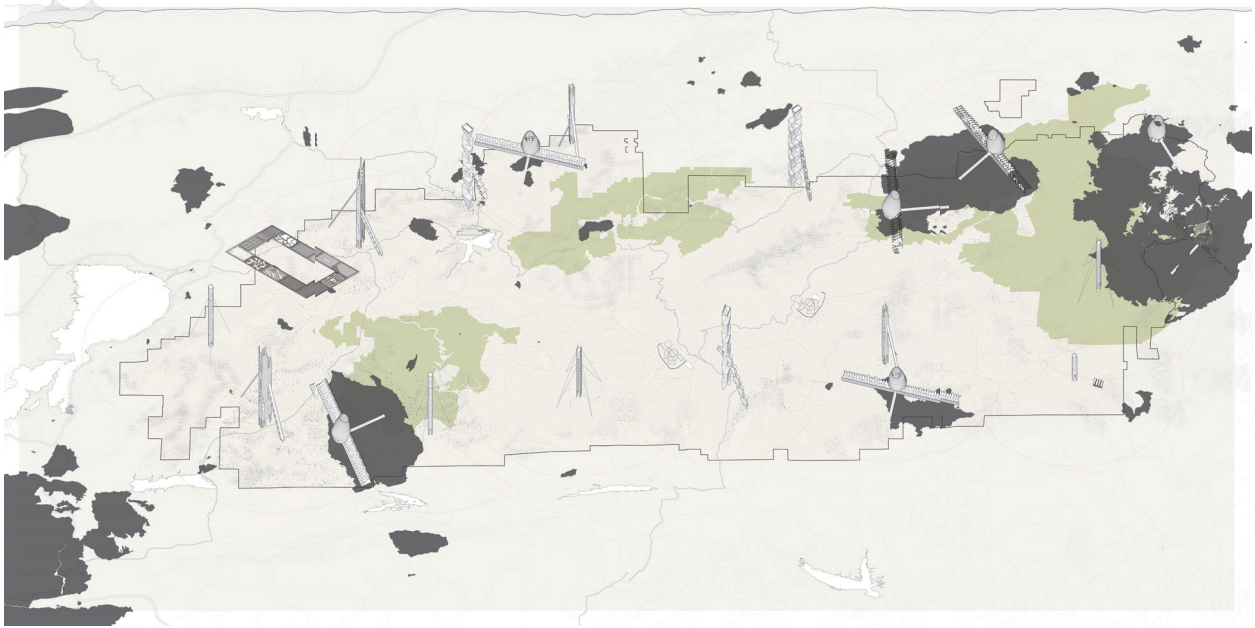

The number of towers vary in size and panel type. However, taken together, they create a fire perimeter protecting suburban houses on the wildland-urban interface from the fires that rage within the forest.

See Appendix B for the complete set of Mendocino Conservation Towers.

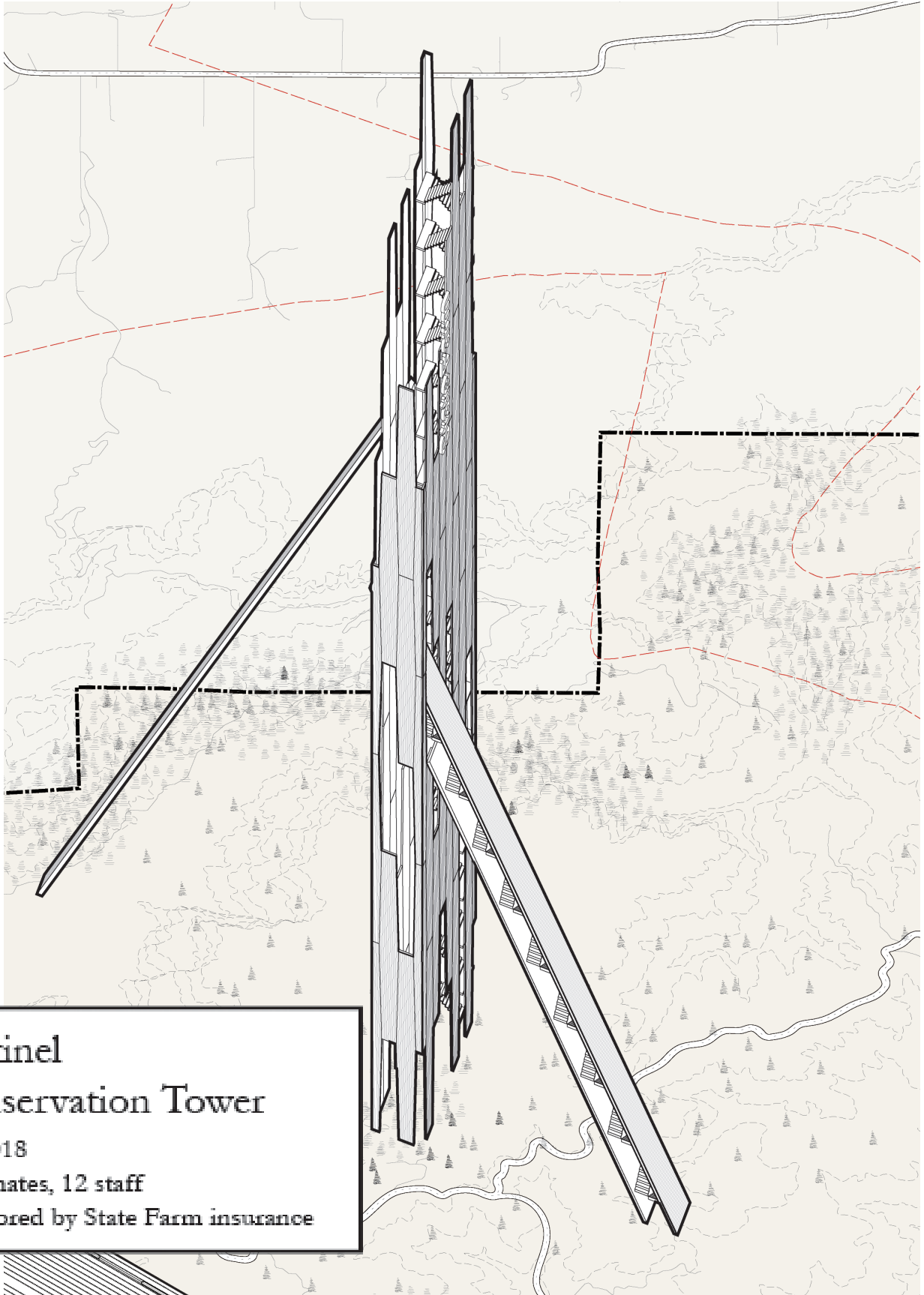

**Sentinel
Conservation Tower**
est. 2018
30 inmates, 12 staff
sponsored by State Farm insurance

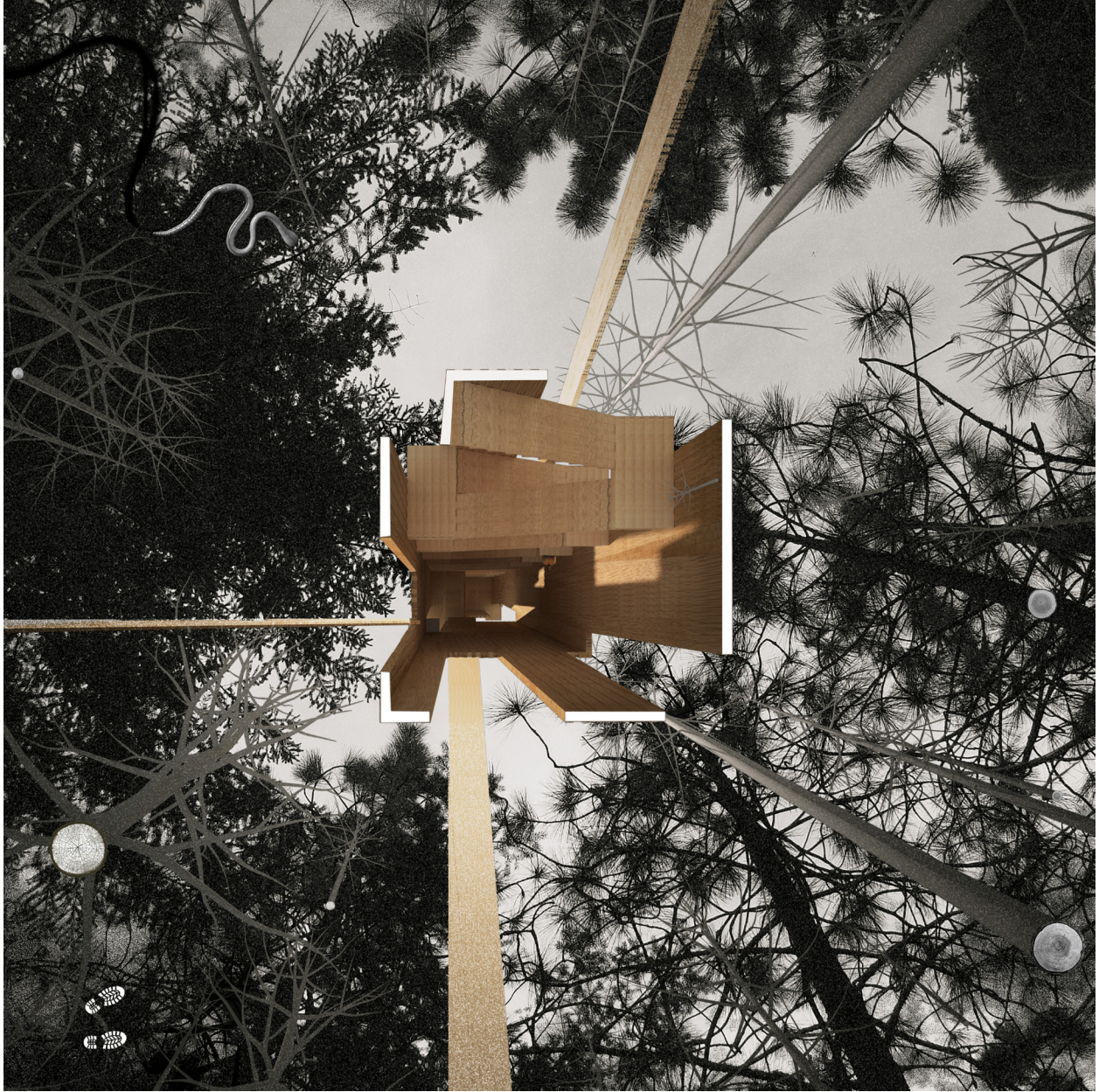



Towers are emblazoned with the name of fire insurance company sponsors. Most nights at the conservation tower end with a collective meeting around the campfire.



In this future forest, inmates are now sentries, watching the landscape change and managing its transition.

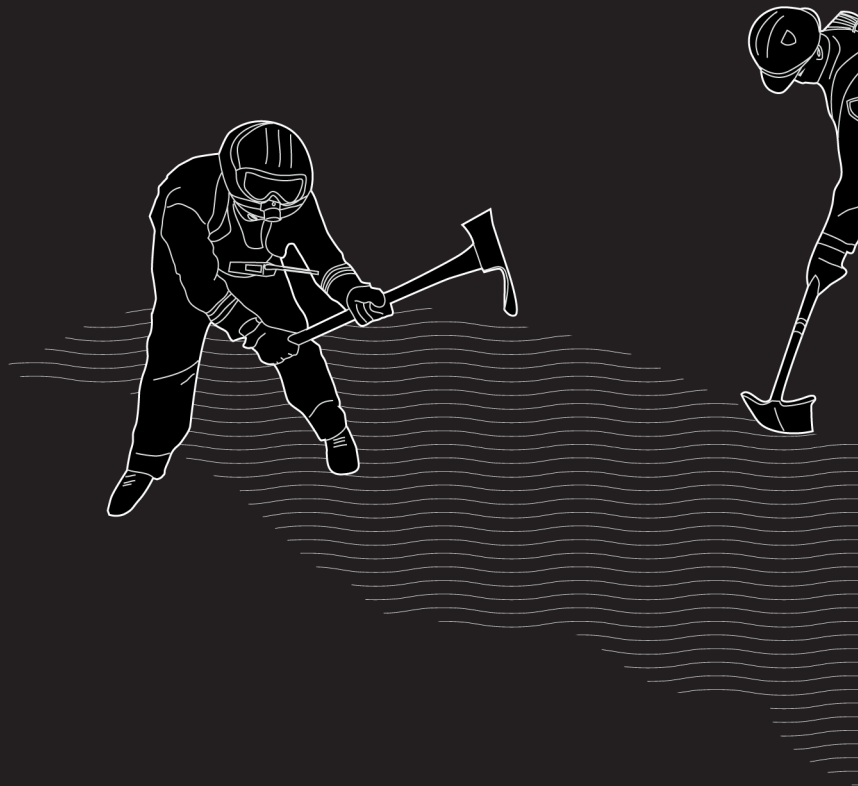



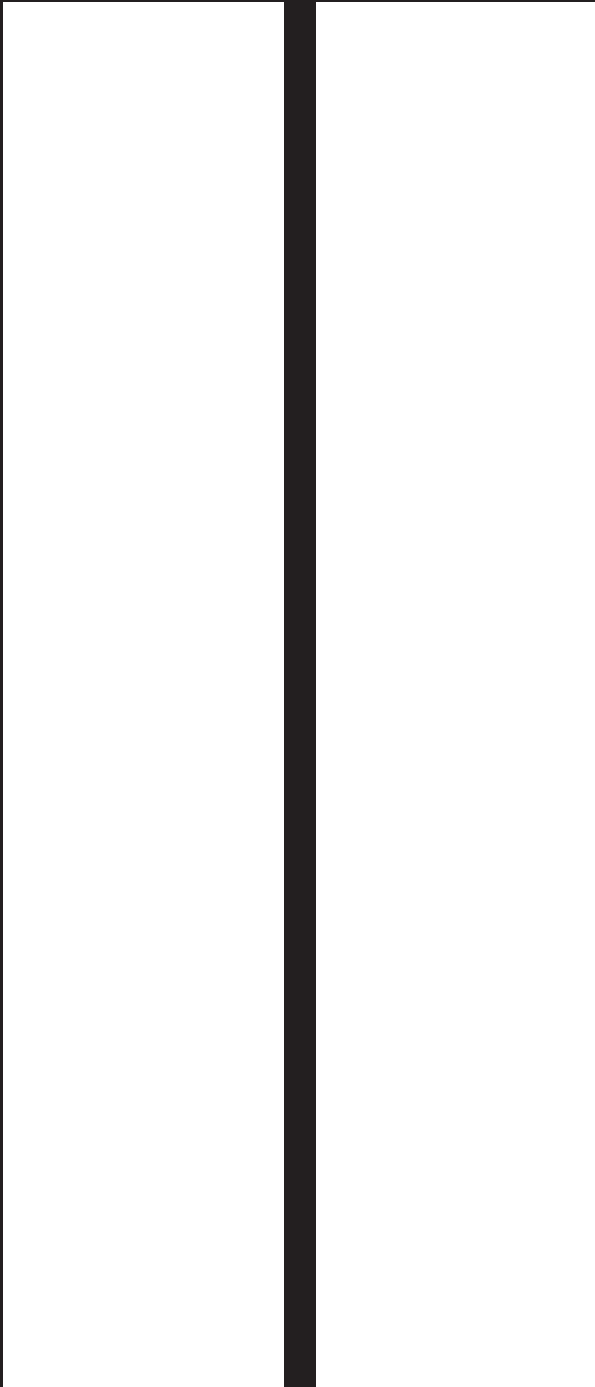

Scavenging in the Afterburn

SALVAGE ECOLOGIES AND THE 'BURNOUT LODGE'





BURNOUT LODGE

While the incarcerated are constantly vigilant, burns are inevitable and not always as damaging as they appear. Many forest inhabitants thrive after fires. One of those species is *Morchela elata*, the black Morel. They are prized as a valuable edible, and collecting Morels - along with several other valuable species - is the primary income of foragers. Foragers, nomads living on the fringe of capitalist society, are particularly drawn to National Forests because of the species that thrive in their human disturbed landscapes.

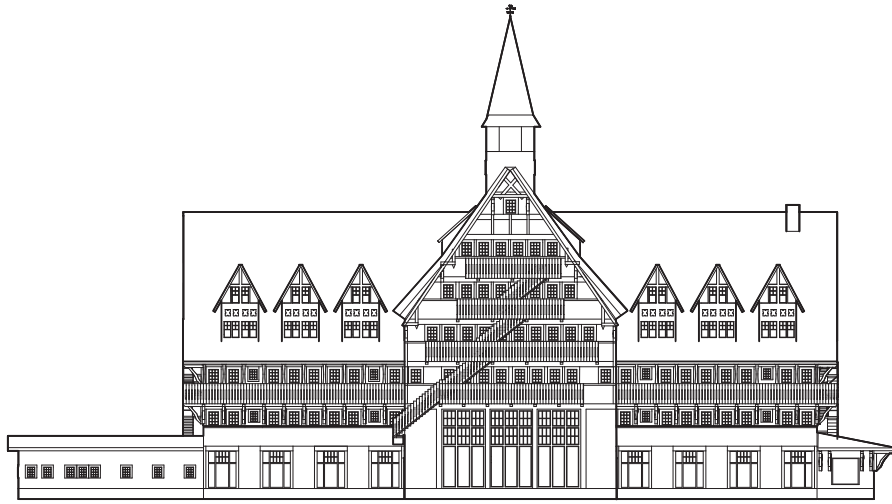

Timberline Lodge



Mushroom Camp

Foragers and inmates are some of the few permanent human inhabitants of the national forest, however, the most significant structures built in national forests have been the rustic timber lodges constructed to house nature tourists. In the forest, mushroom foragers live on the margins, living

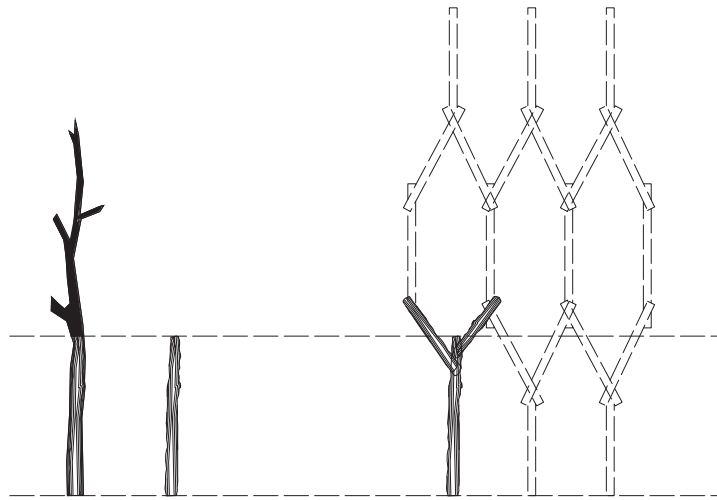

Timber Salvage

The Burnout Lodge is a lodge constructed to house mushroom foragers and visitors on the site of recent burns, allowing access to areas deep within the forest. After a large burn, it's a common but controversial practice to 'salvage log' dead, but still valuable, burned trees. This practice removes habitat for some species, such as the Black Billed Woodpecker in Mendocino.

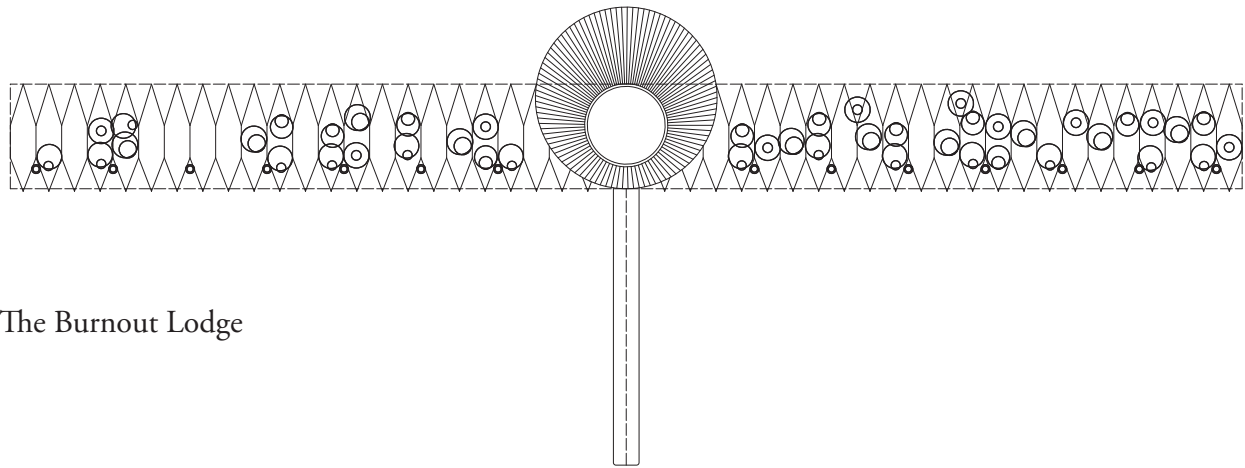
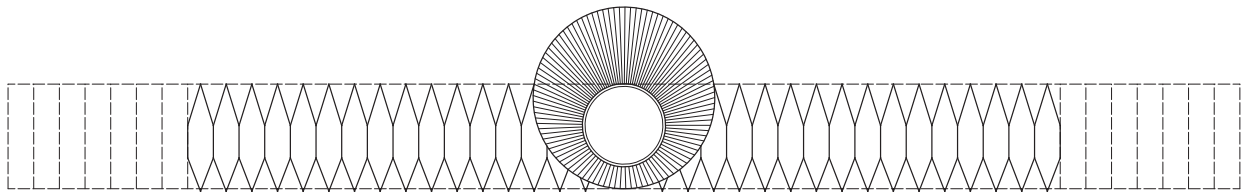

The Burnout Lodge

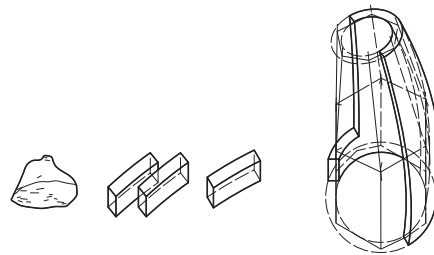

Mushroom mycelium pod





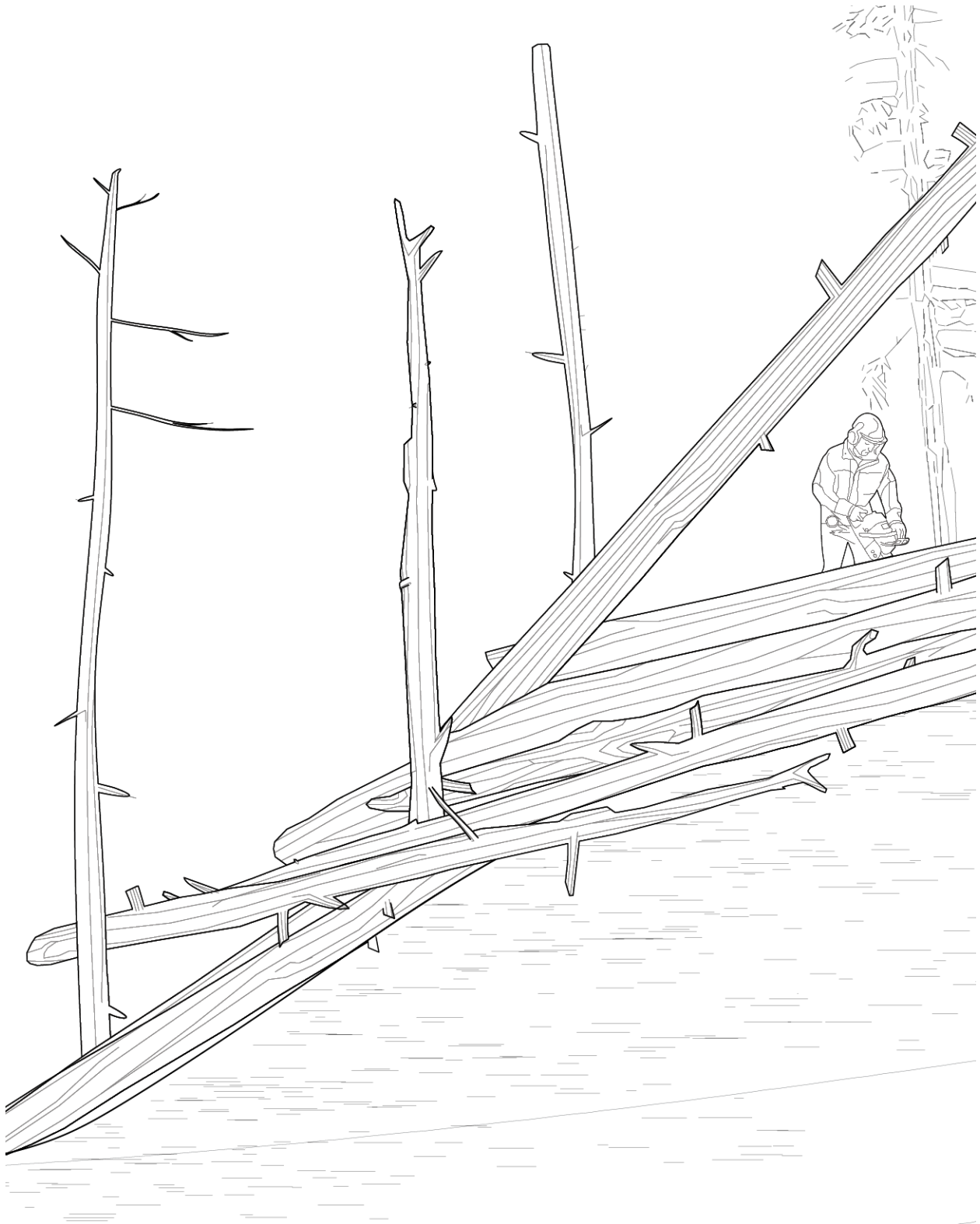

Instead of removing this material, the burnout lodge uses this burnt wood - with the help of robotically cut joinery - to construct housing on site. The burnt timber frame is infilled with mushrooms.

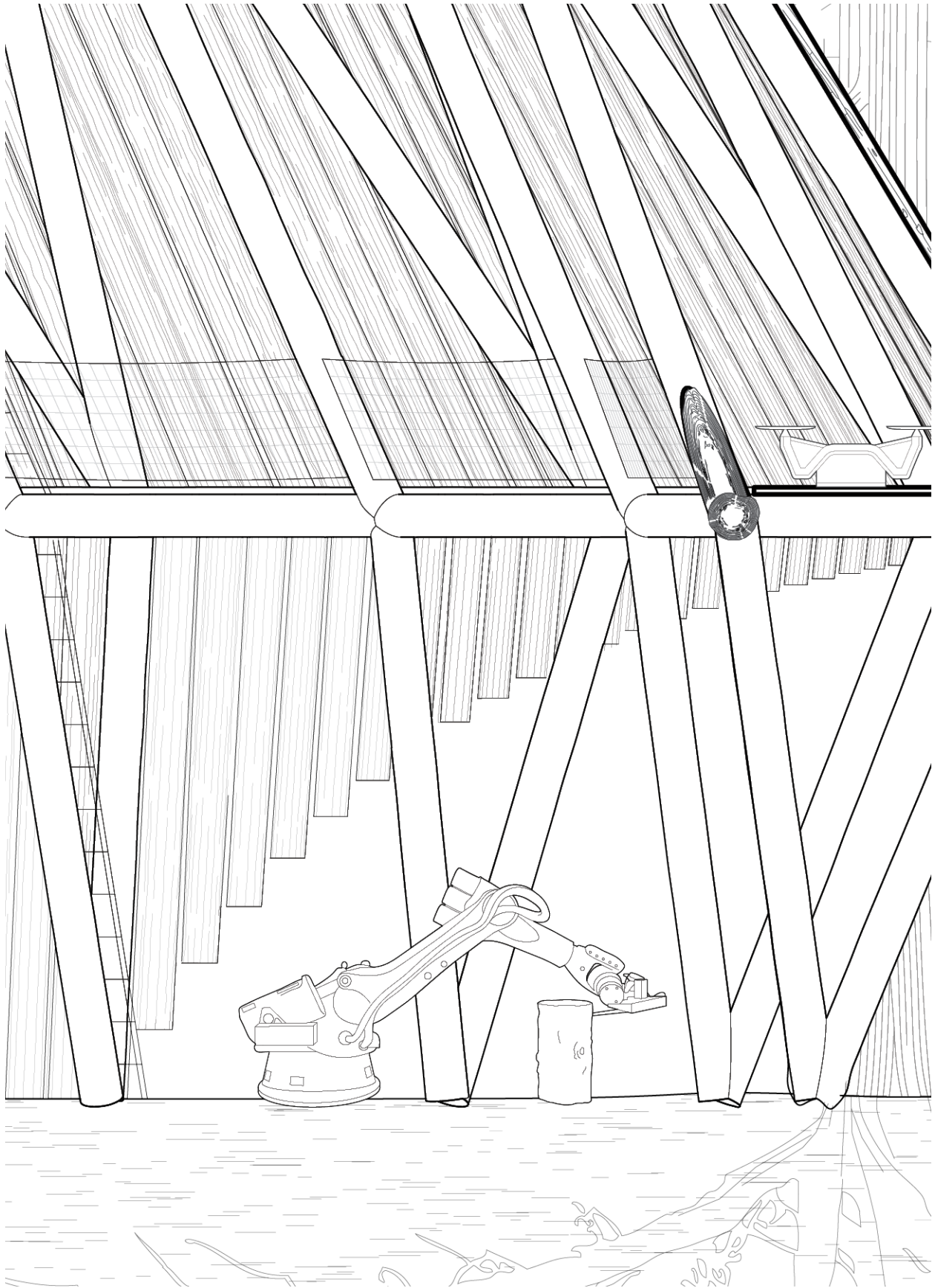



The Meeting Hall is the center of activity at the Lodge. The hall acts as drone port, timber workshop, public plaza, and is where nightly mushroom auctions are held.

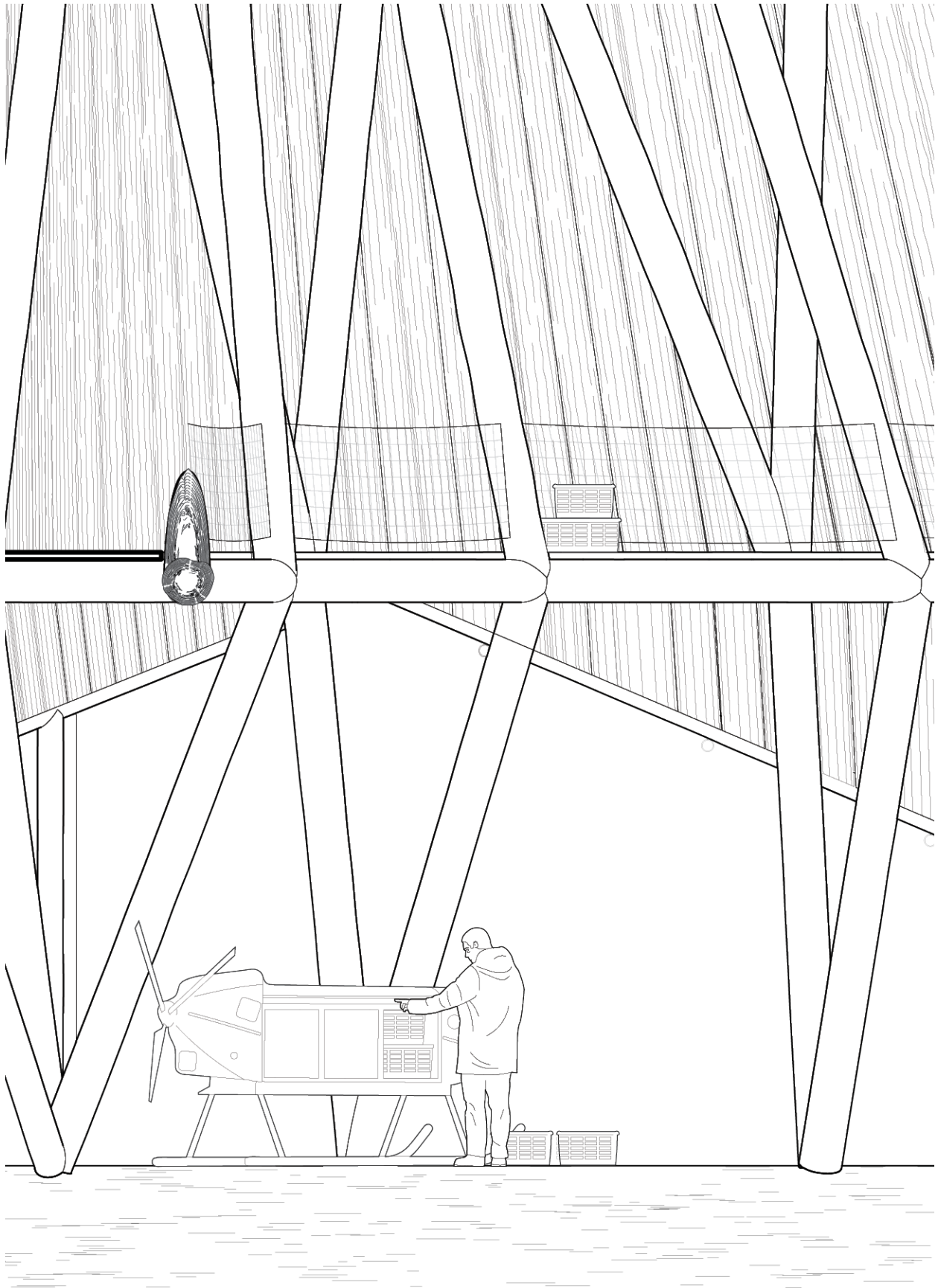

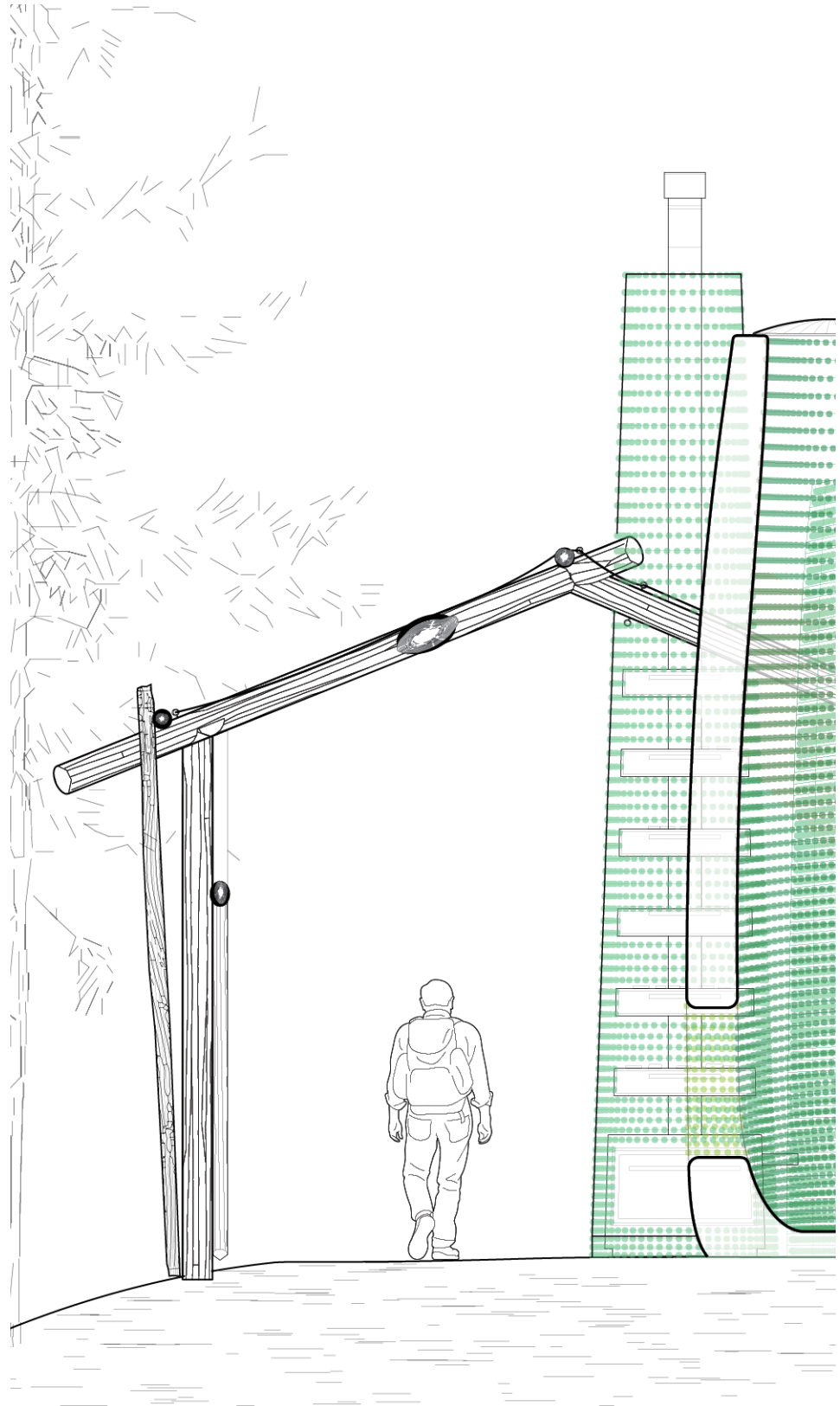

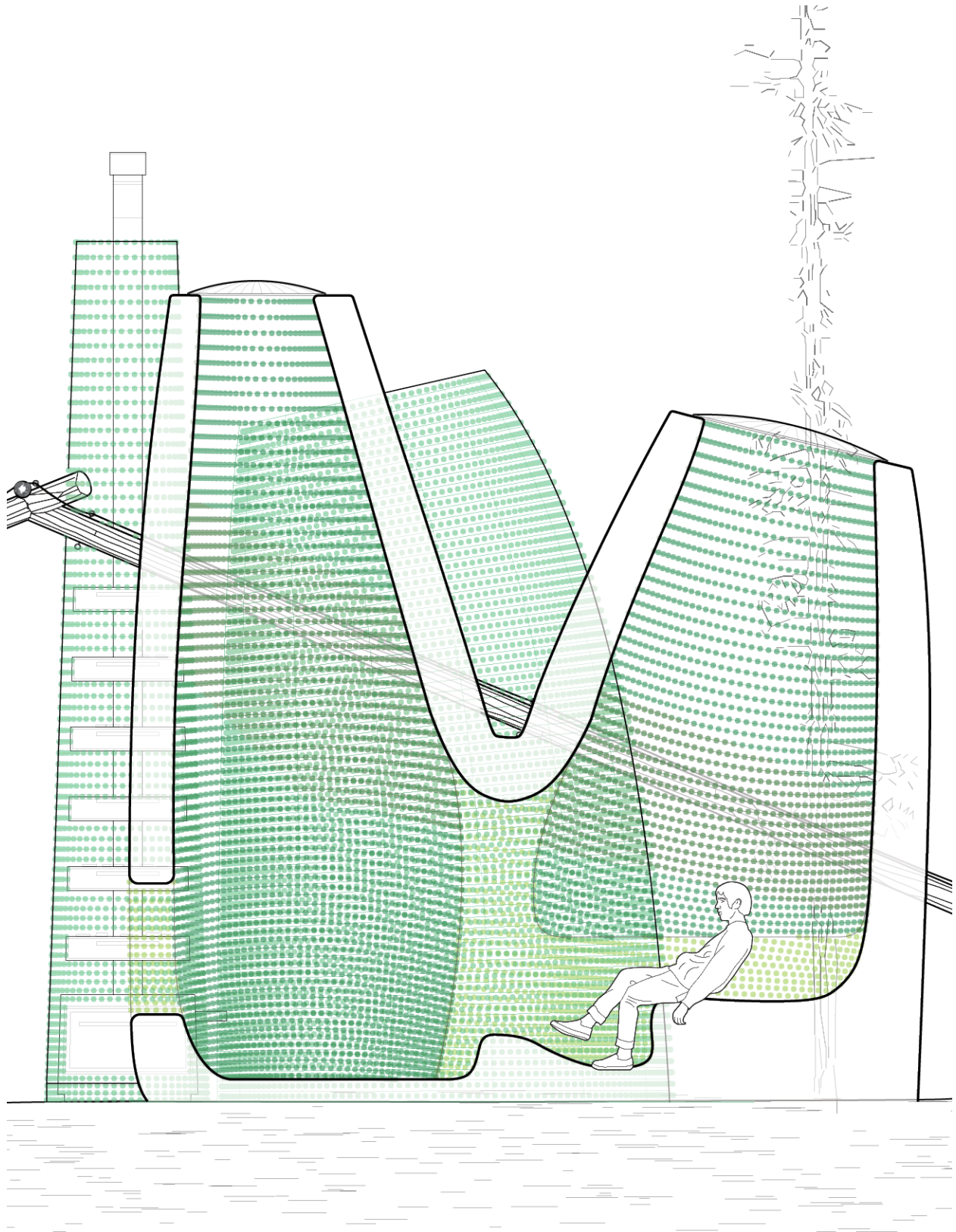

Mushroom dehydrators and dream pods are constructed from mycelium brick, grown from mushrooms and sawdust on site.



Aldo Leopold Lodge
under construction
to be completed by morel first flush

The forest currently contains six Lodges, in differing stages of use or abandonment.

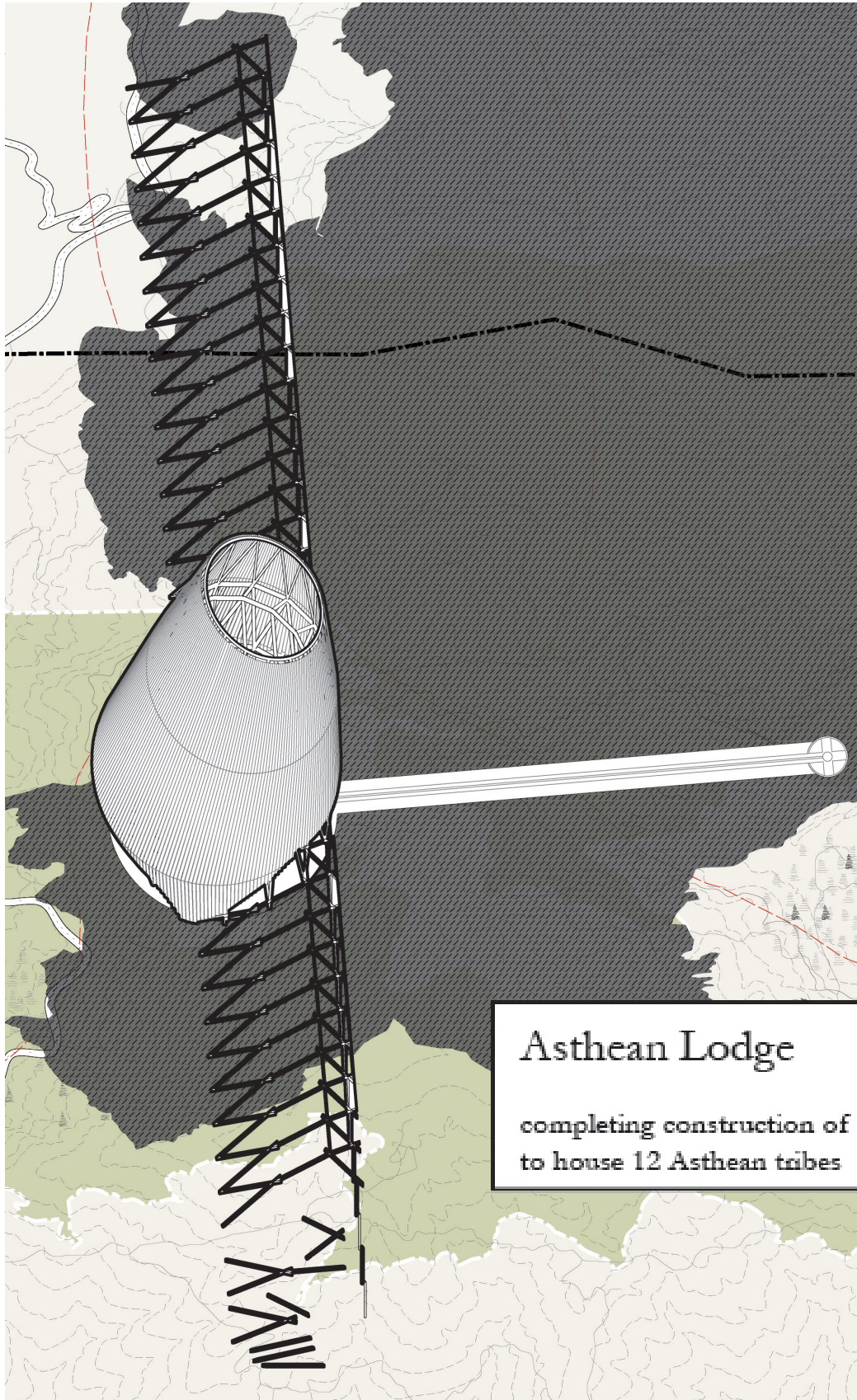

Asthean Lodge
completing construction of frame
to house 12 Asthean tribes

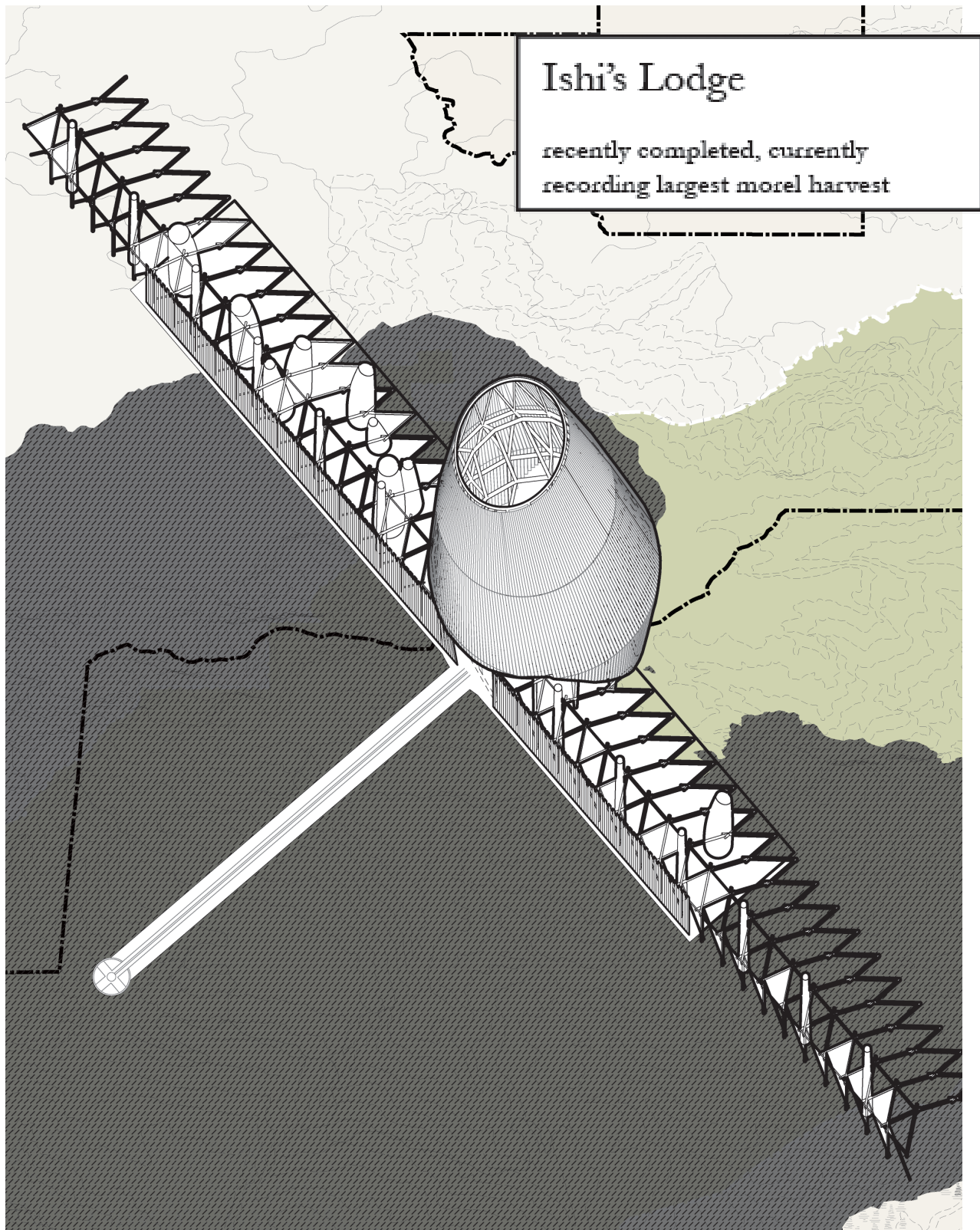

Ishi's Lodge

recently completed, currently
recording largest morel harvest

The unique names speak to Californian forest history and the individual culture of each Lodge.

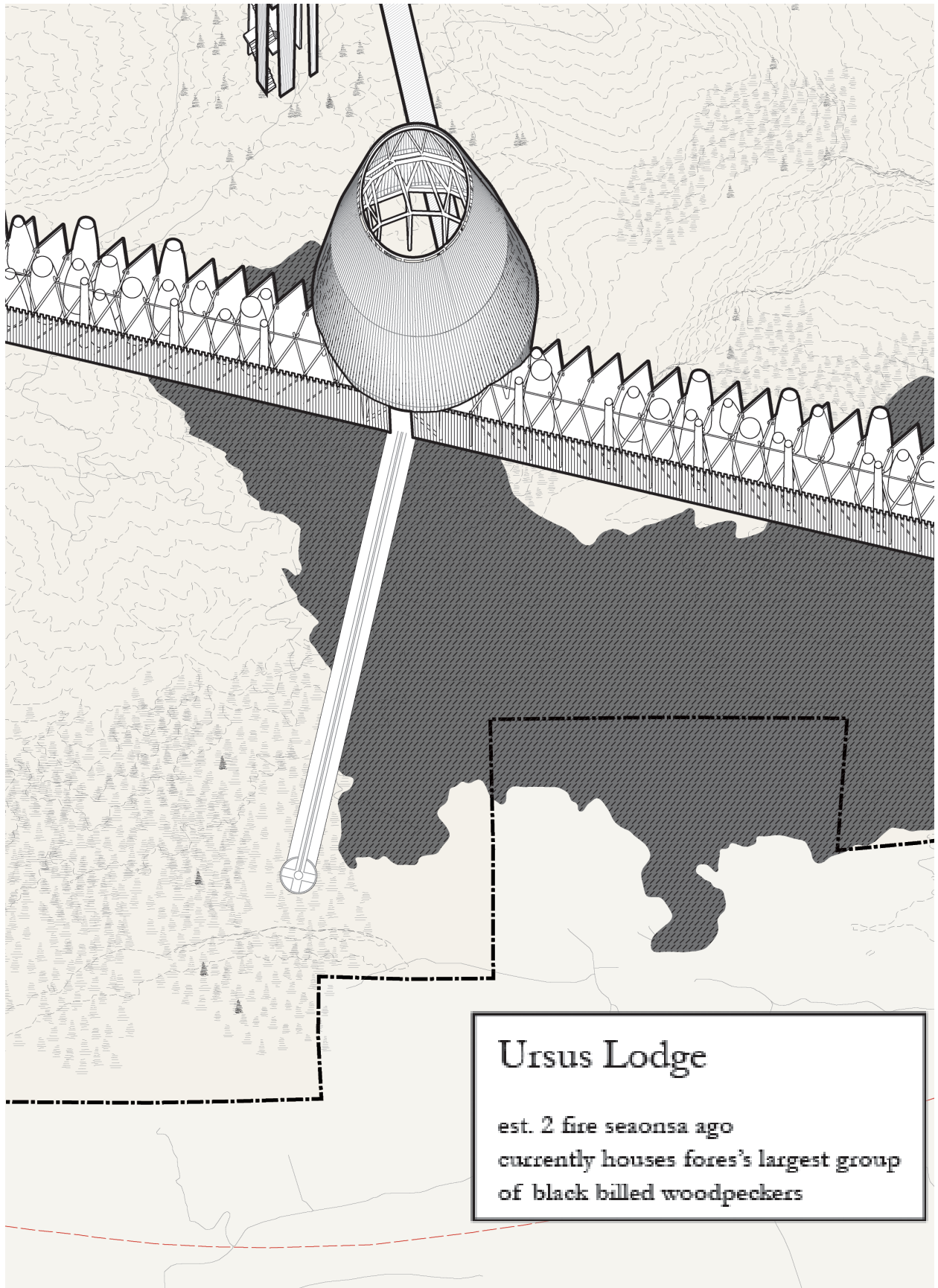

Ursus Lodge

est. 2 fire seasons ago
currently houses forest's largest group
of black billed woodpeckers

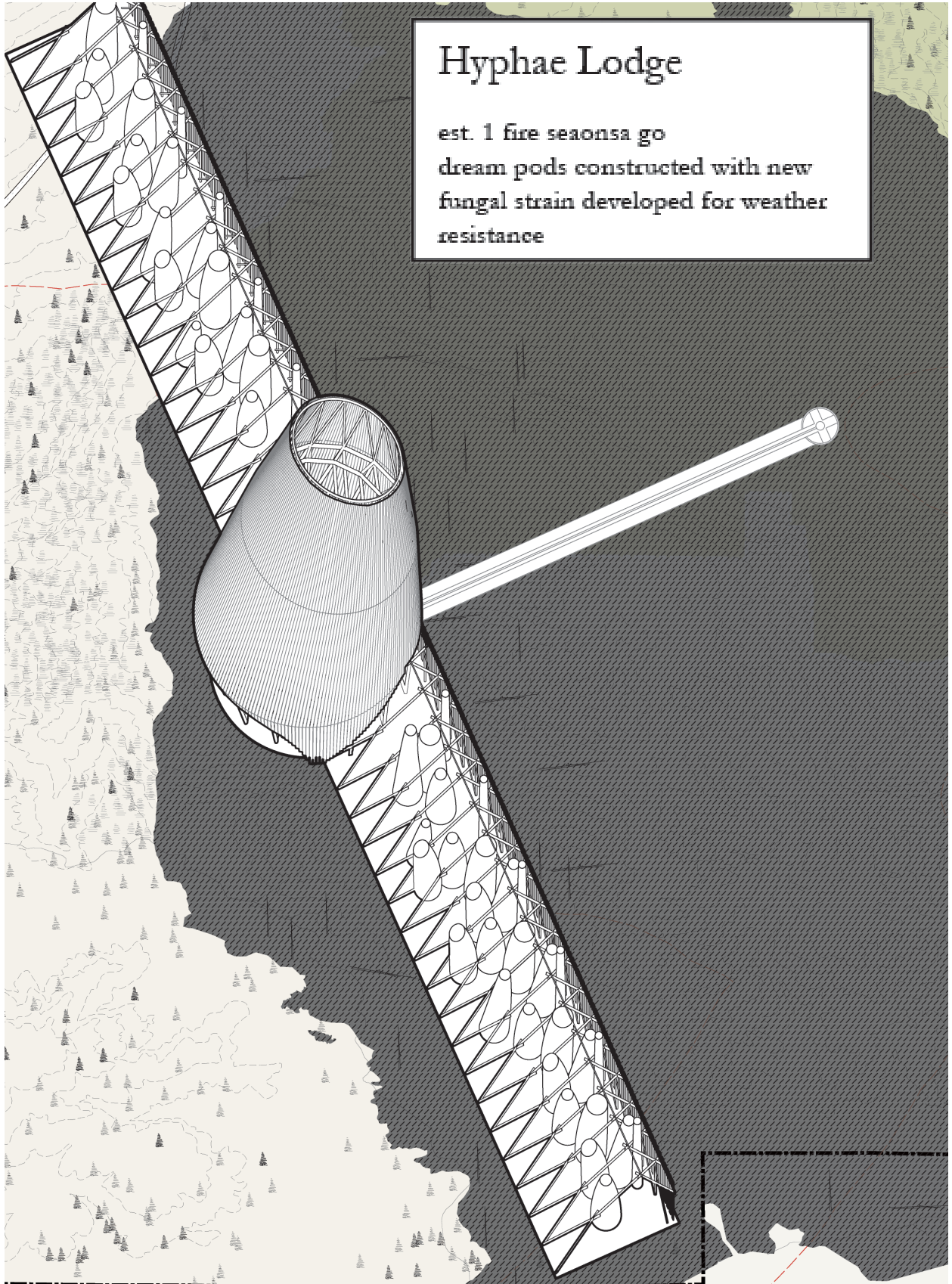

Hyphae Lodge

est. 1 fire seasons ago
dream pods constructed with new
fungal strain developed for weather
resistance

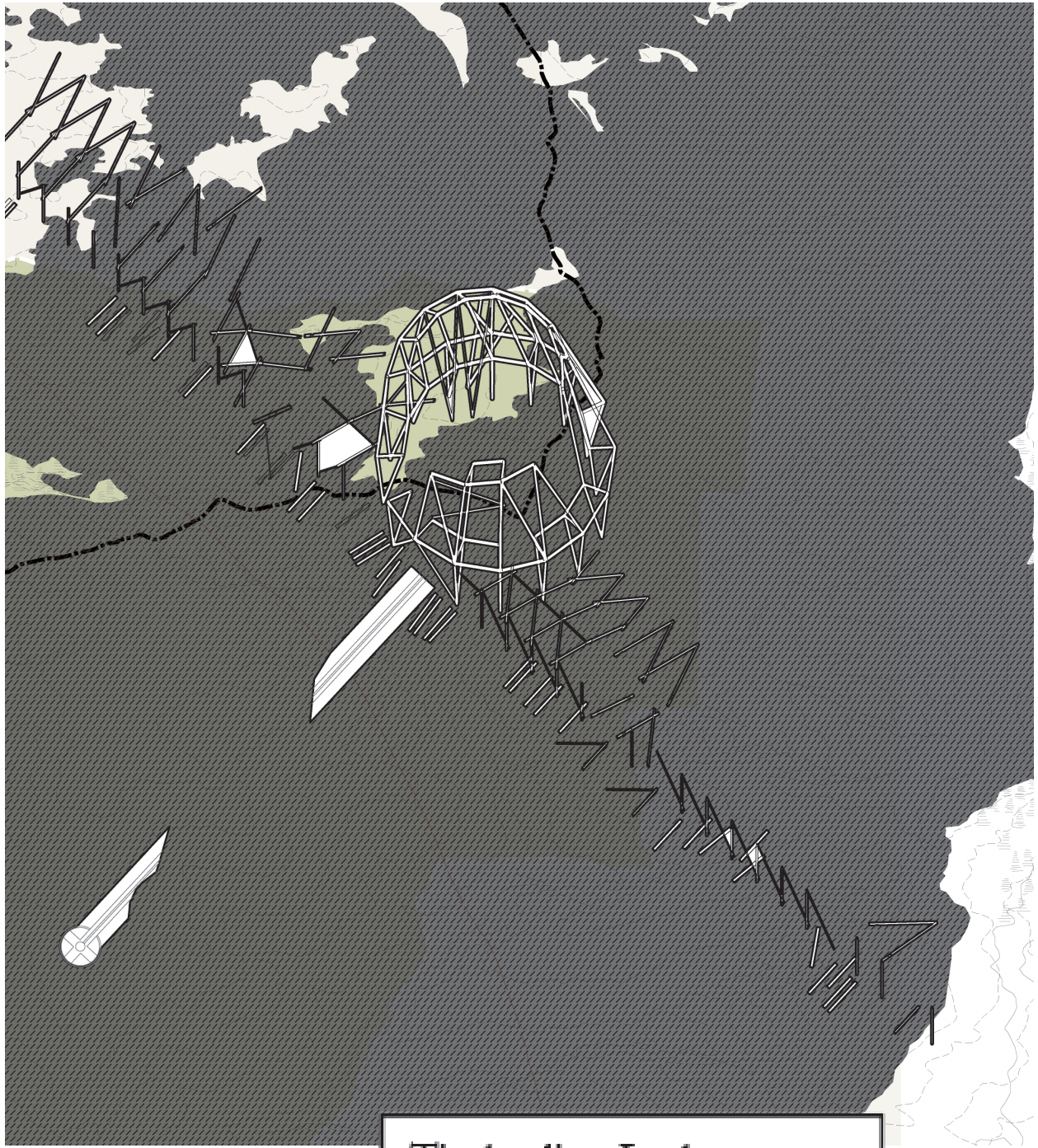

Timberline Lodge
est. 7 fire seasons prior, burned this
fire season

Like everything in the forest, the lodge is temporary.



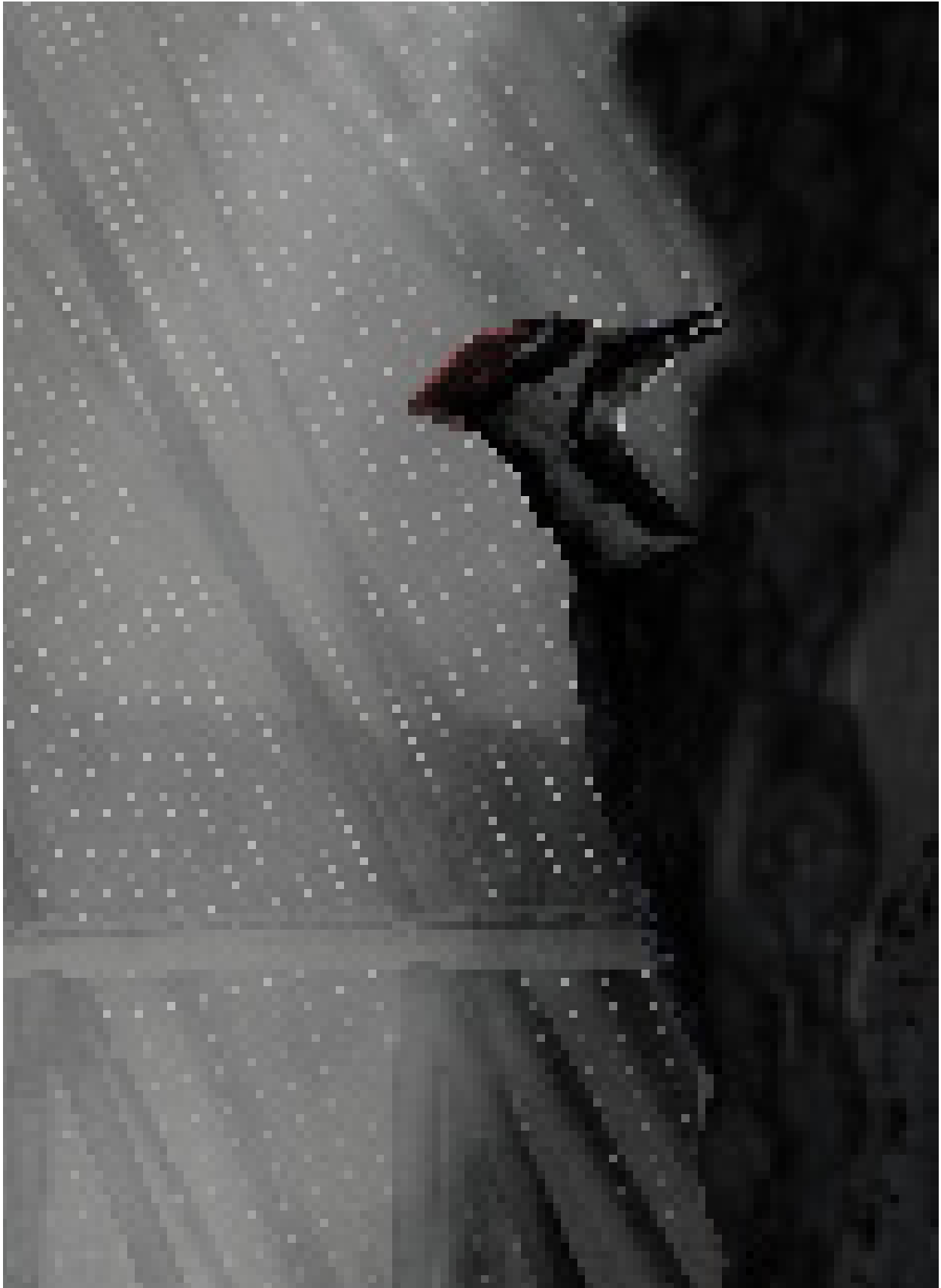



Once the mushroom prospects dry up, foragers follow the smoke to the next burn, leaving the lodge to decompose and eventually burn.



**“yet the modern
human conceit is
not the only plan for
making worlds: we are
surrounded by many
world-making projects,
human and non-
human.... “humans,
pines, and fungi make
living arrangements
simultaneously for
themselves and for
others: multispecies
worlds”**

Anna Tsing
*The Mushroom at the End of the World:
On the Possibility of Life in Capitalist Ruins*



Dream pods house the foragers and visitors in their fungal embrace.

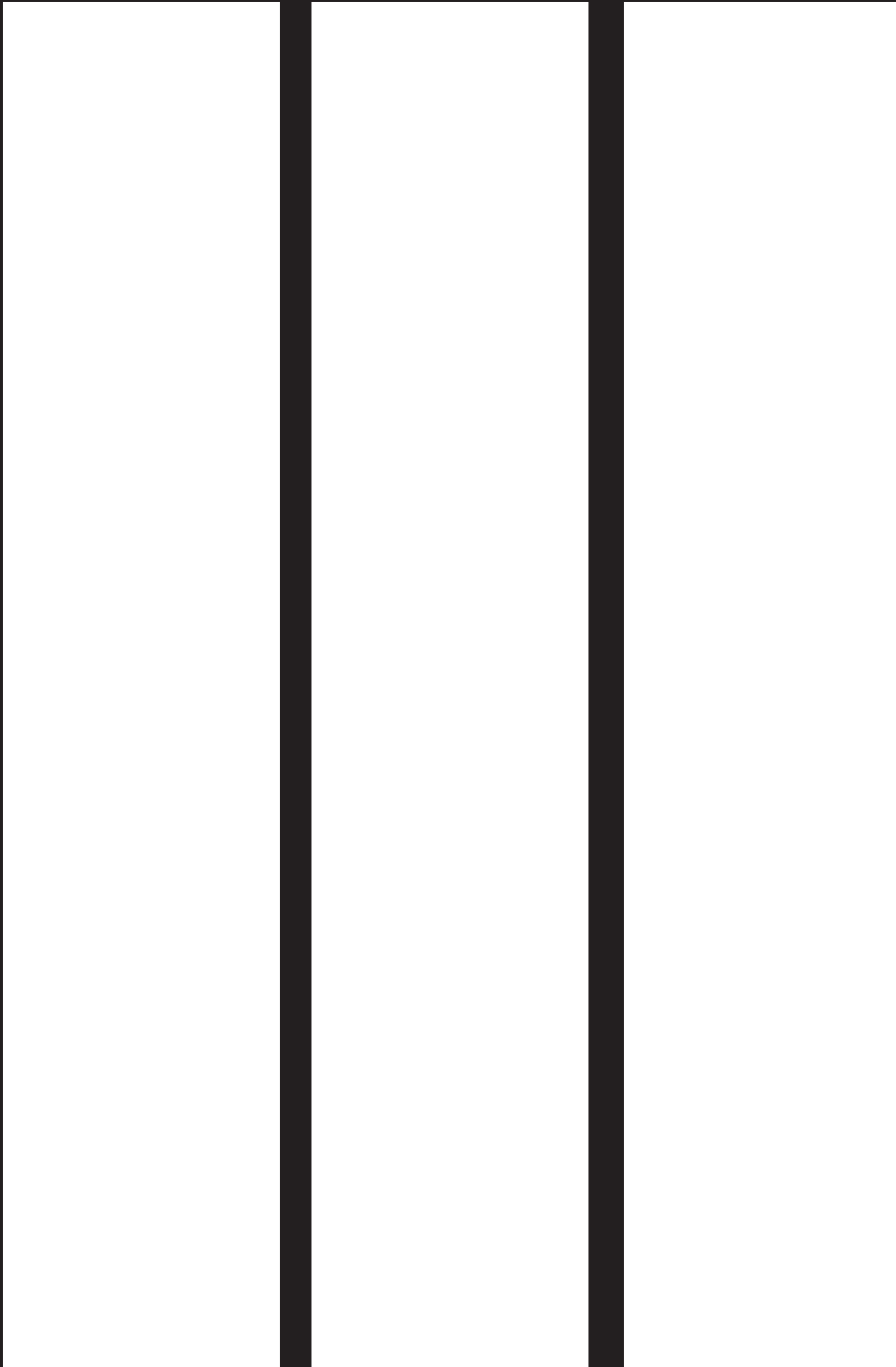

Rituals of Production

A CHRISTMAS TREE PLANTATION FOR THE BAY AREA
'YULE LOG FARM'

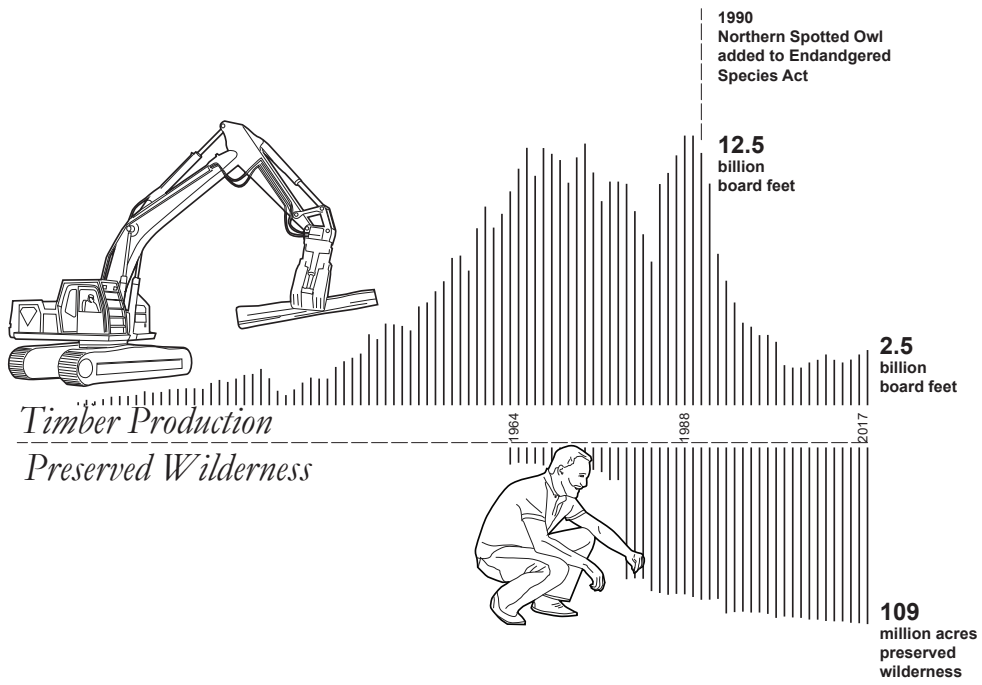

PRODUCTION

After a large burn and salvage logging, the forest service will often replant trees to speed up forest regeneration. This practice belies the original purpose of National Forests, sustained timber production. National Forests were originally designed for logging and grazing at levels that could be sustained 'for future generations.' However, following a brief logging frenzy in National Forests following World War II, timber production has declined dramatically. At the same time, conservation and recreational interests have grown.

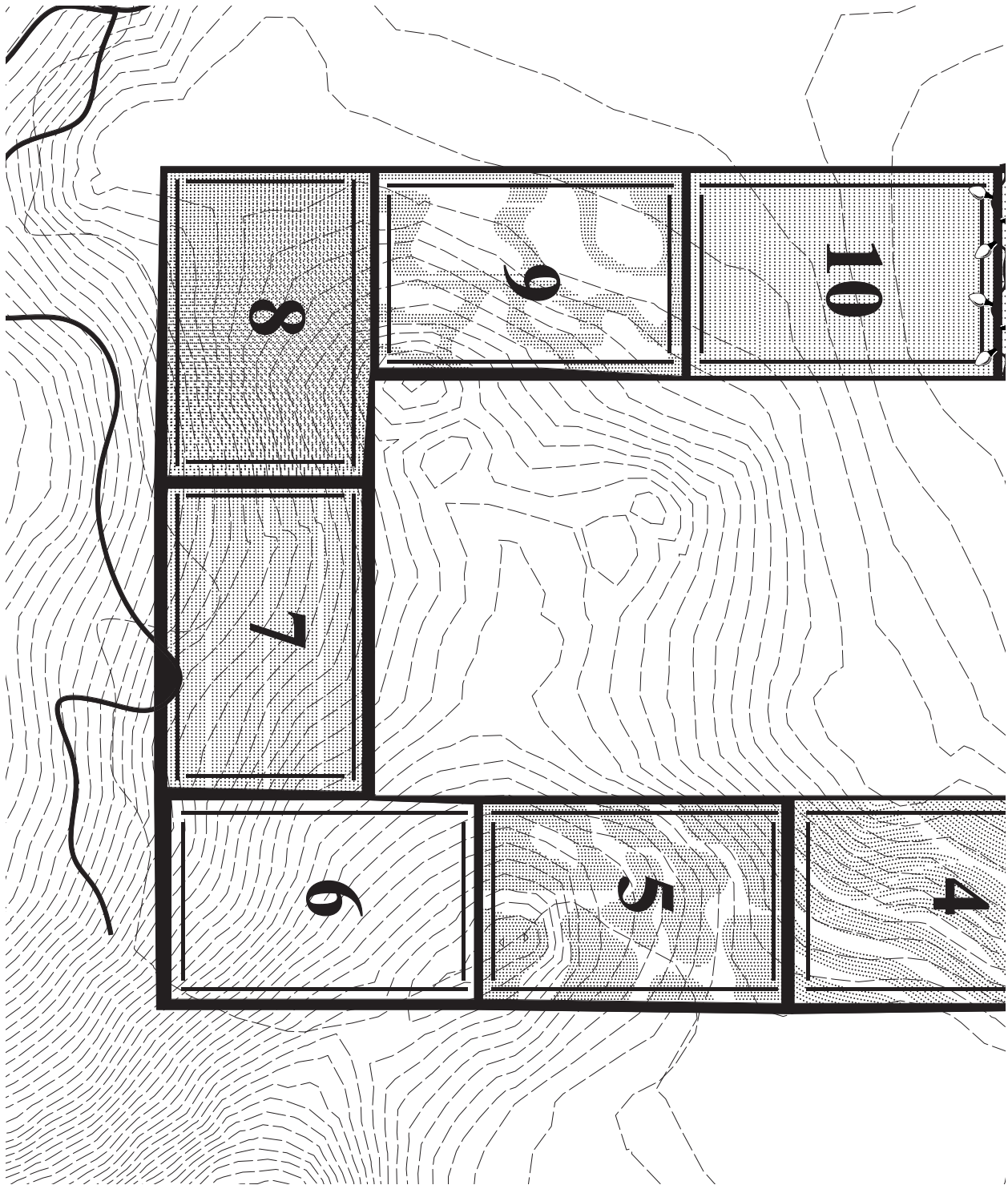

Conservation is a fickle term. National Foresters once thought that prohibiting even light burning was the best way to conserve our national timber resources. It is only recently that the ecological value of frequent prescribed burning has been recognized by the Forest Service. And in fire-paranoid California, prescribed burning continues to be rare.

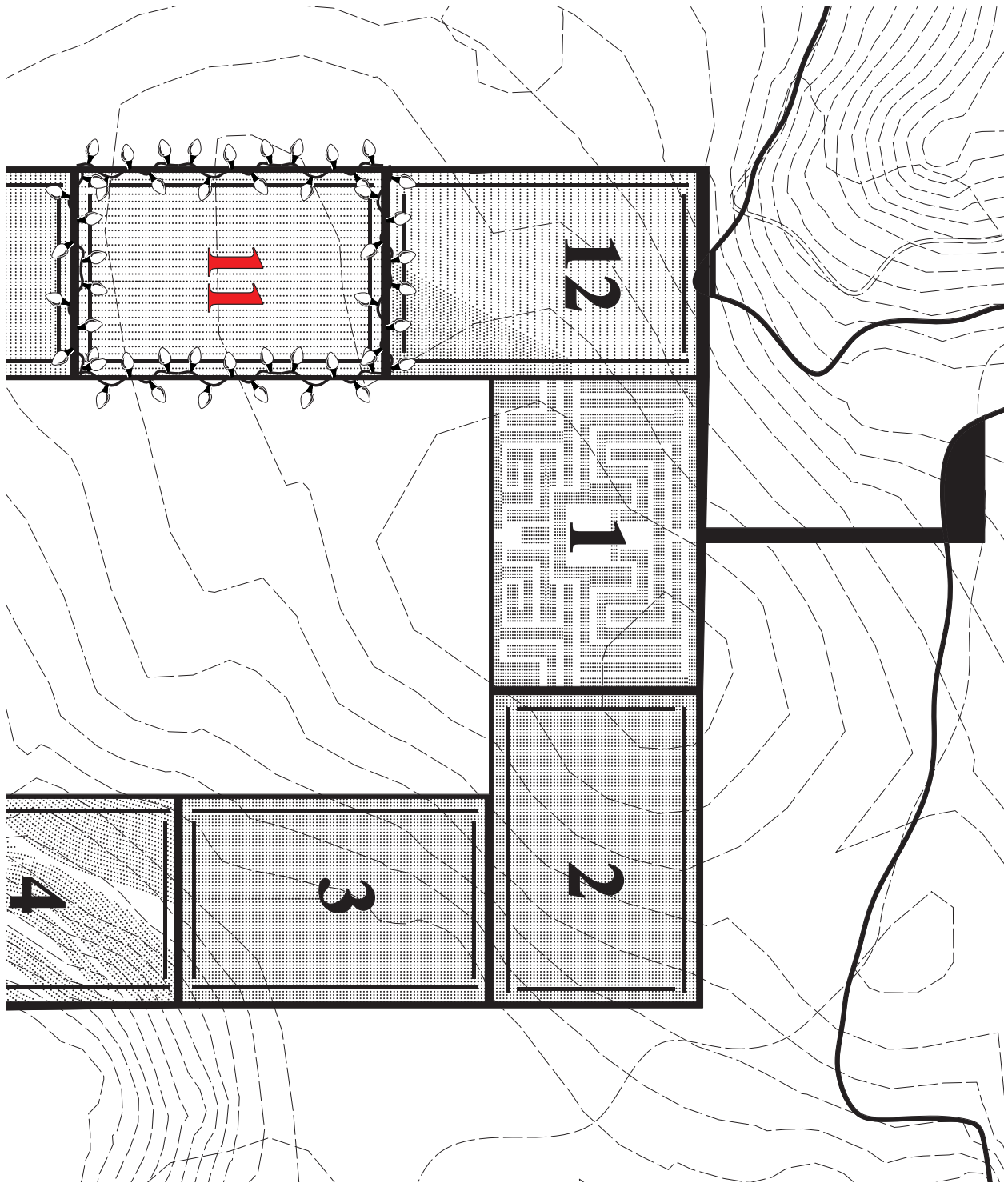

The Yule Log Farm provides a safe space to build awareness of prescribed burning in the guise of a Christmas Tree plantation. The plantation is divided by fire breaks into twelve sections.

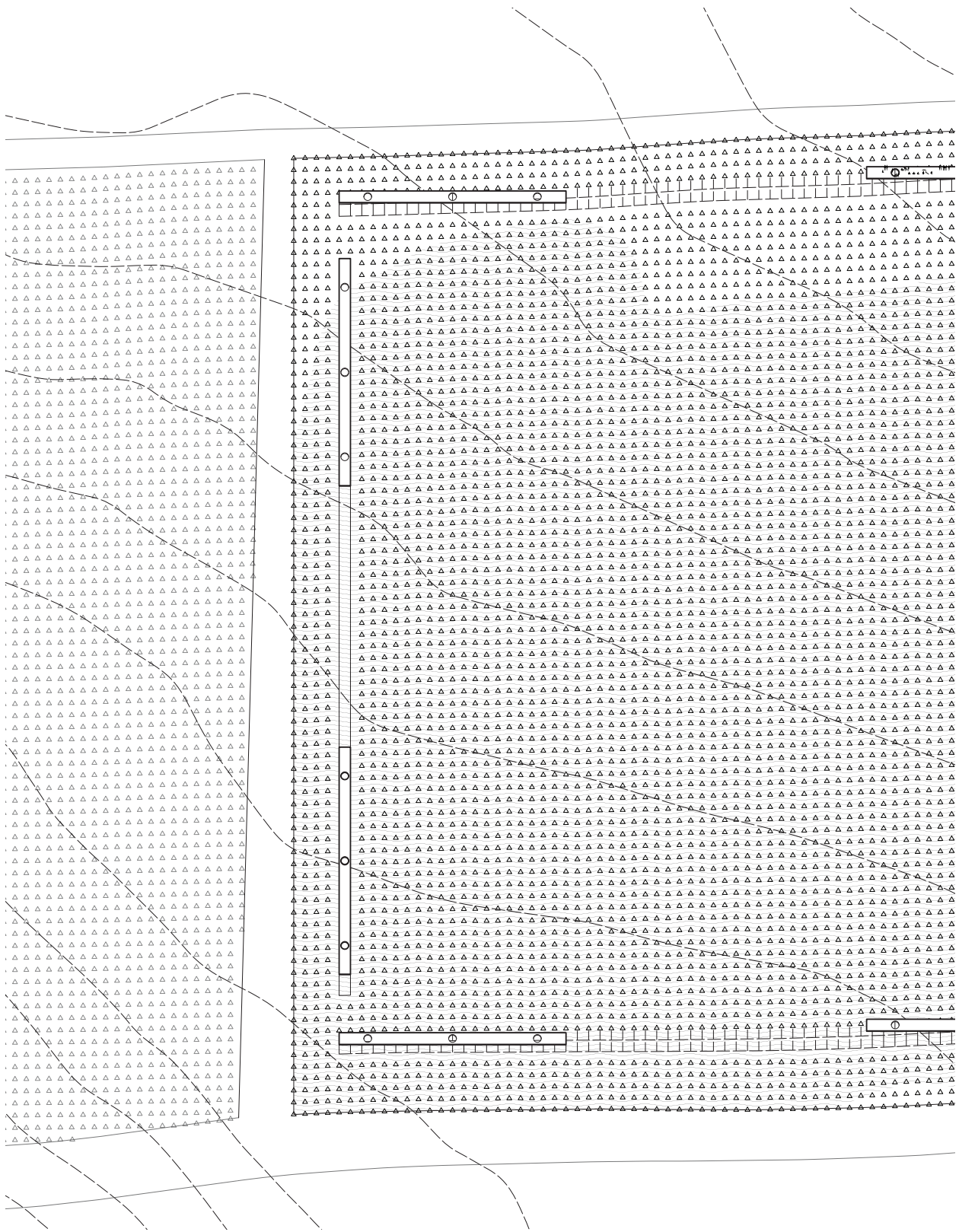

Every year, one section is burnt as part of a large public celebration, re-creating natural fire regimes.

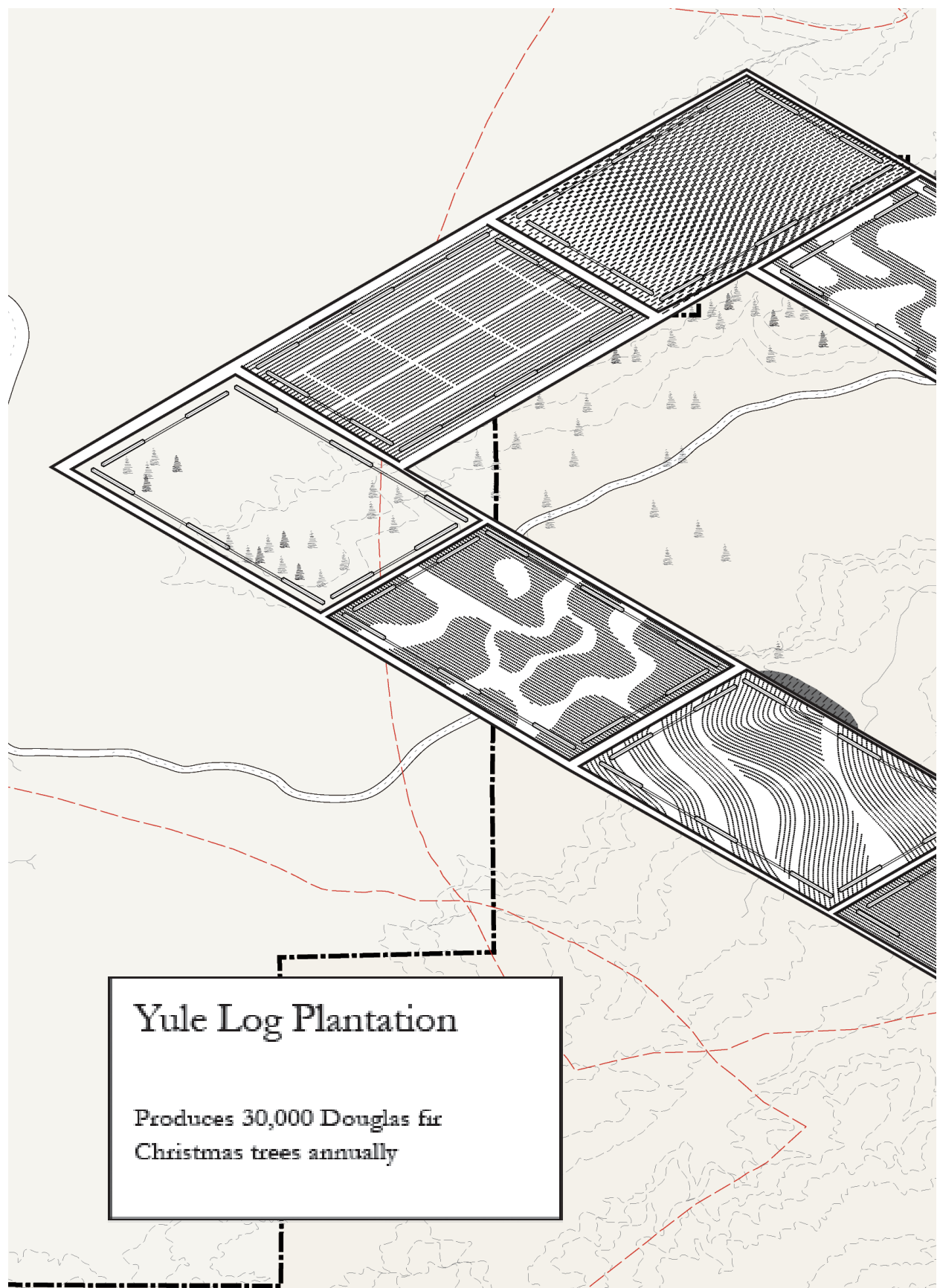

Yule Log Plantation

Produces 30,000 Douglas fir
Christmas trees annually

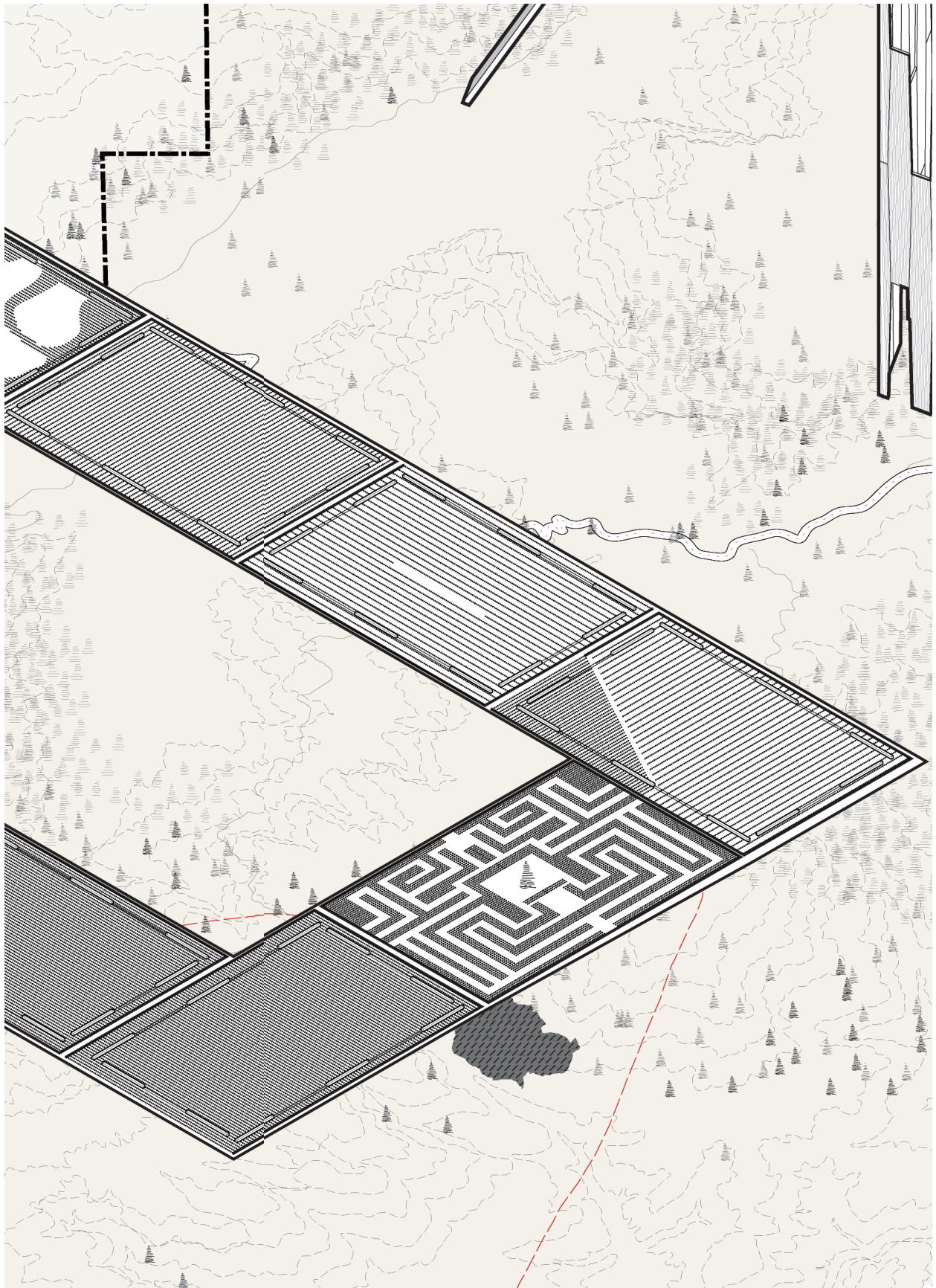

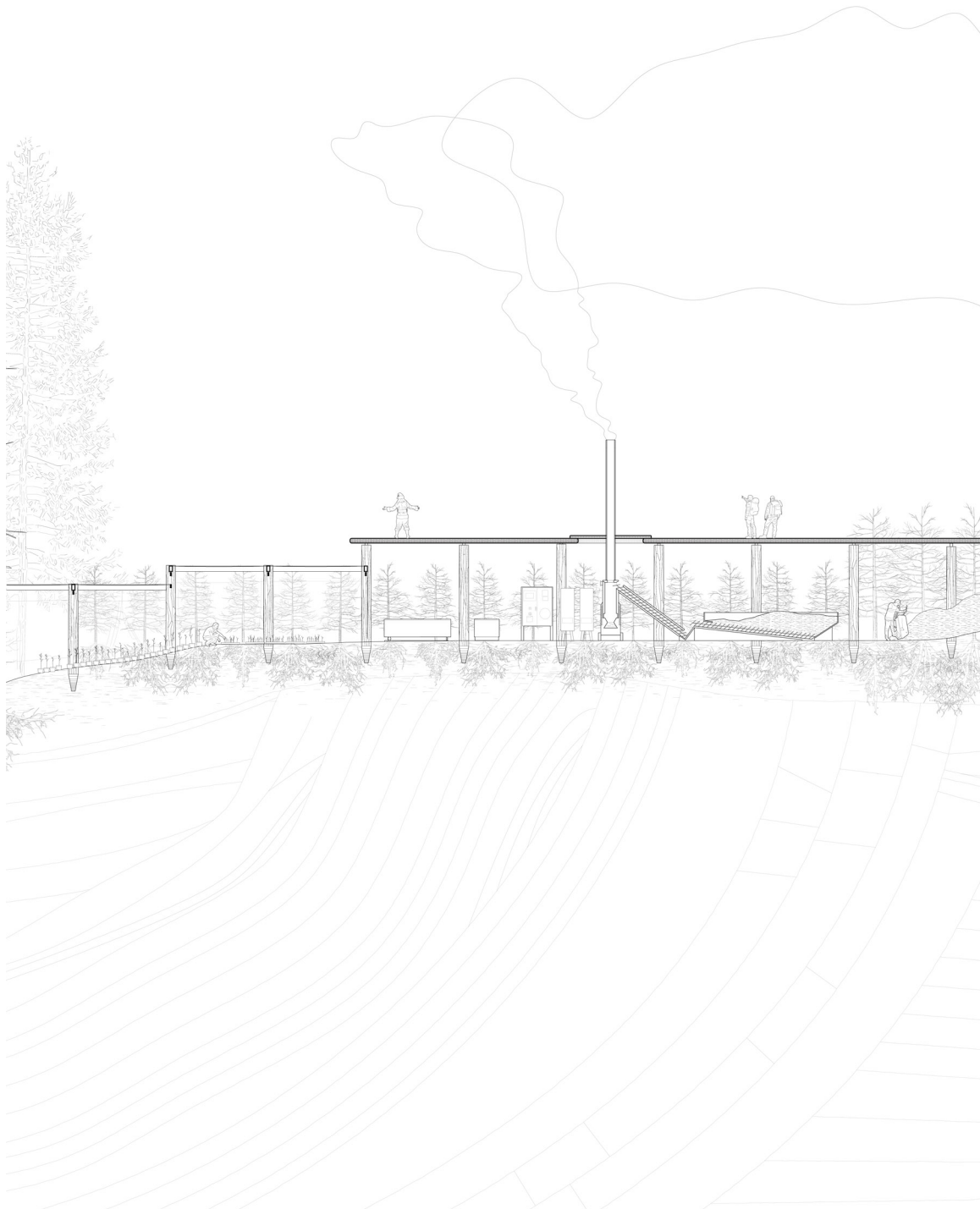

Every year, one section is burnt as part of a large public celebration, re-creating natural fire regimes. Every December 21st, the shortest day of the year, one of the twelve sections is burned in the climax of San Francisco's fire worship calendar.

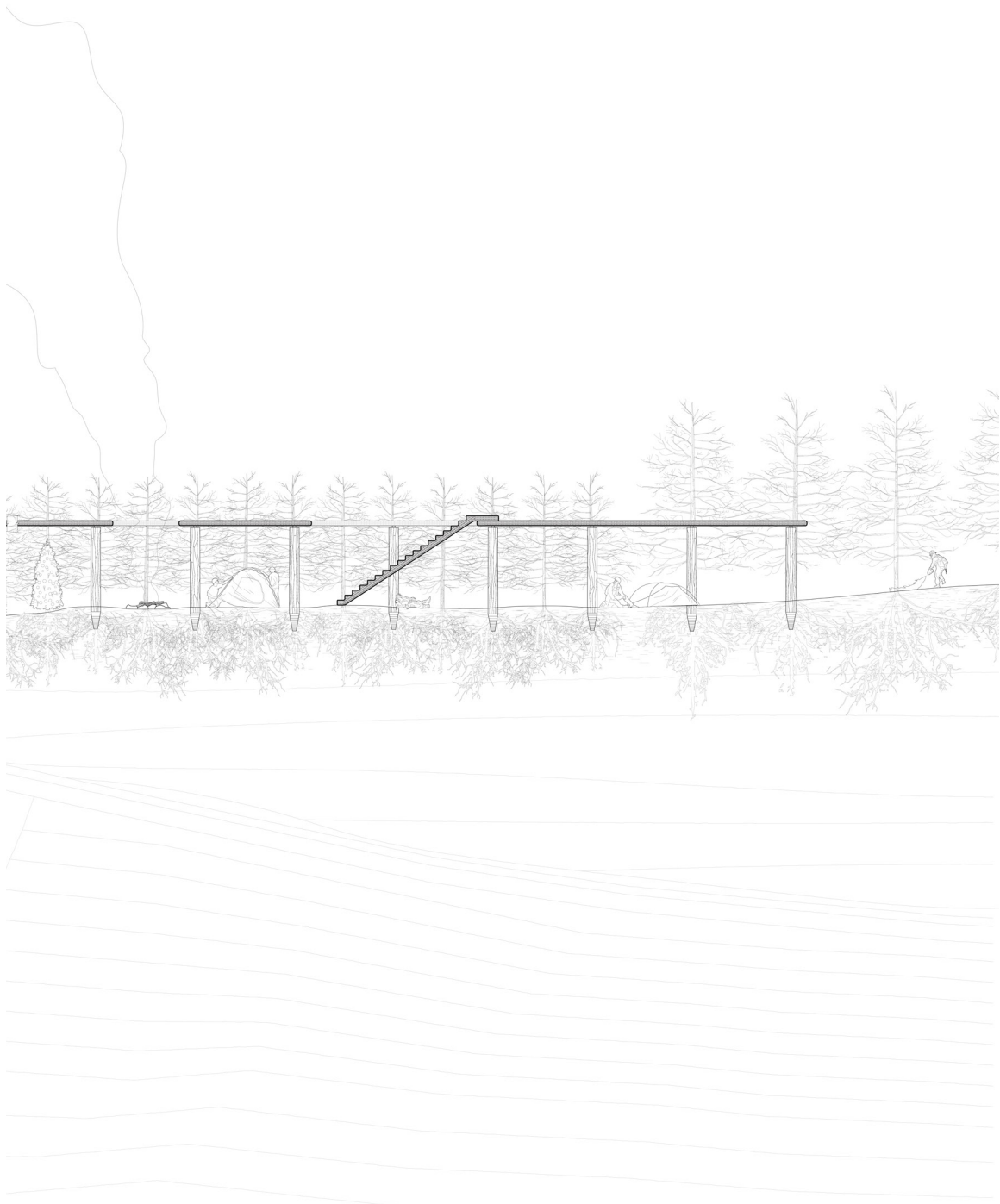

The farm is also home to two types of structures, both also designed to burn.

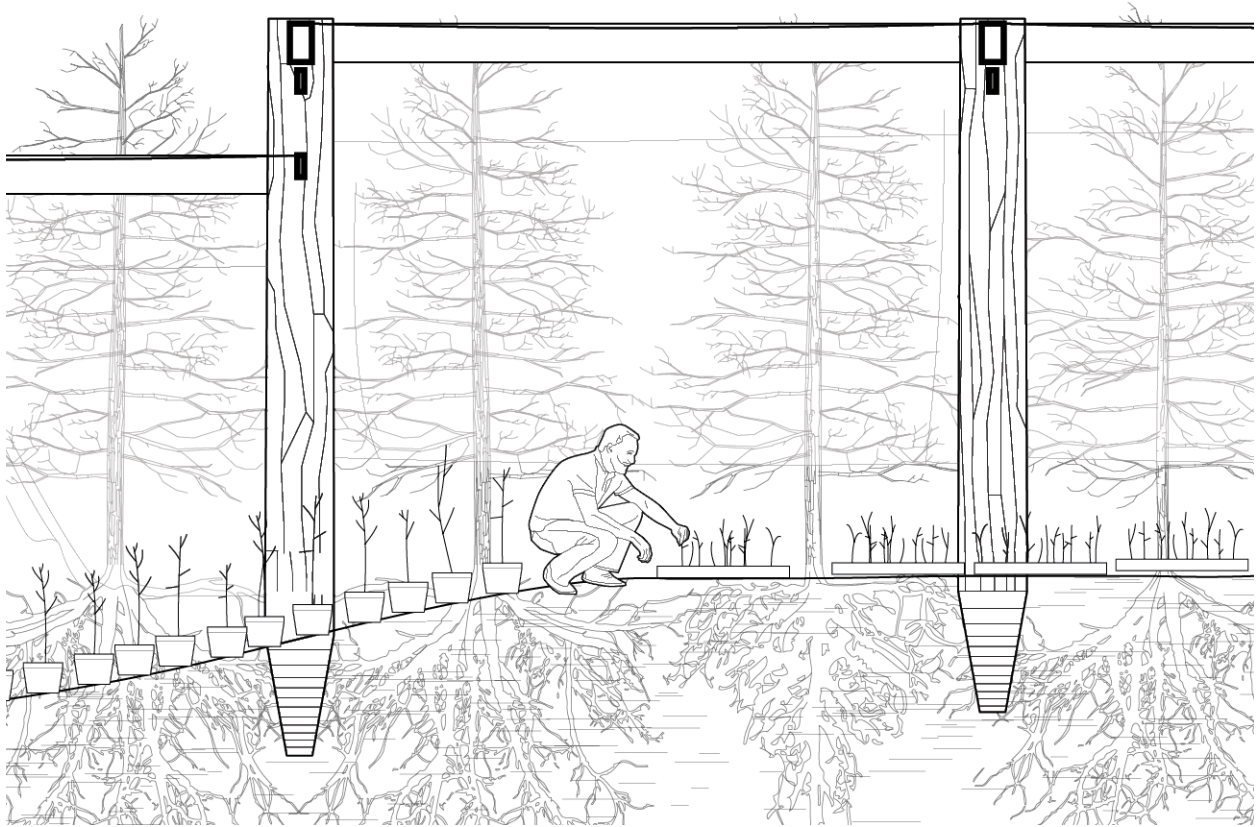

The Nursery is a temporary greenhouse where baby Christmas Trees are reared.



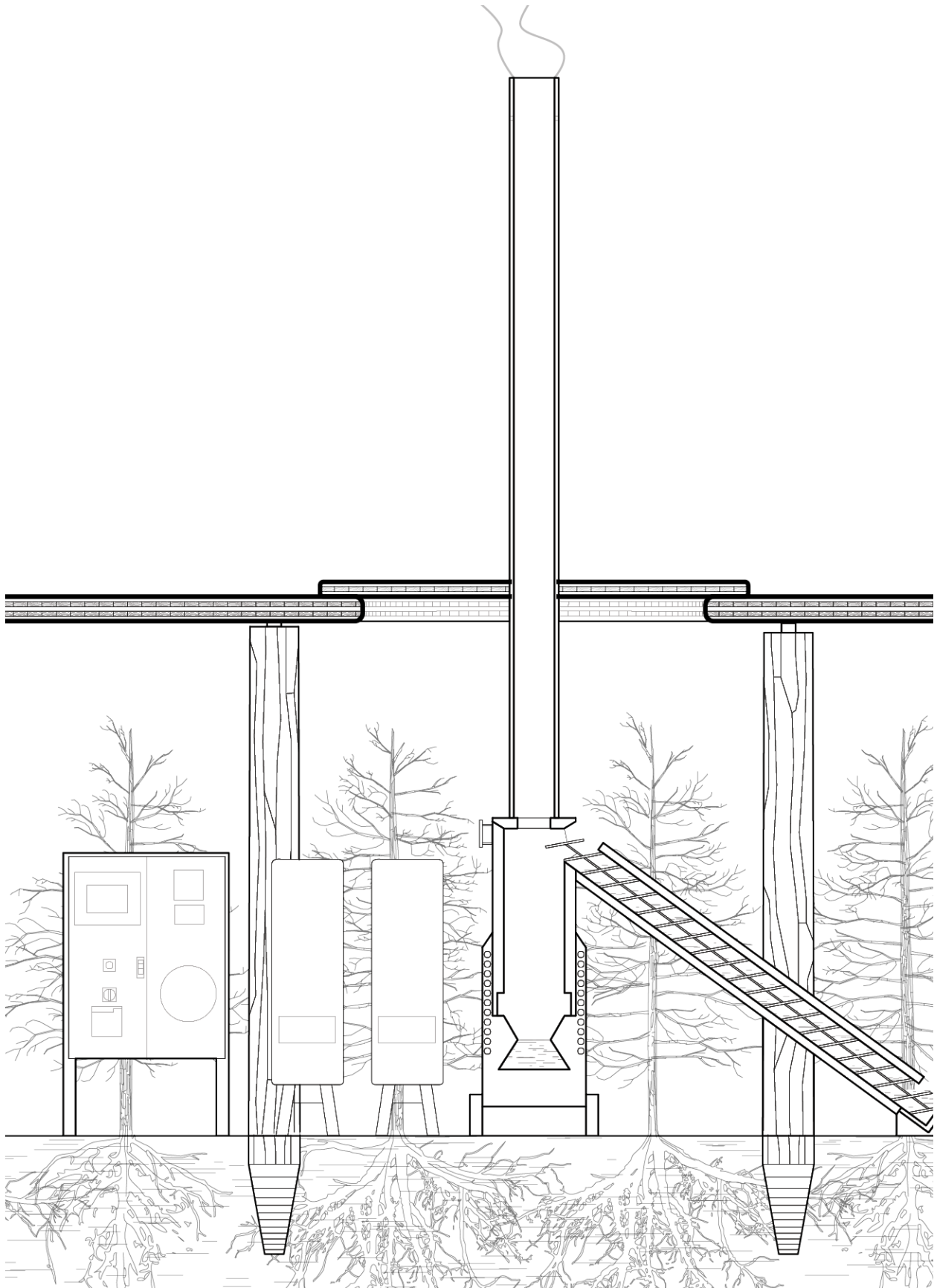

The Nursery lights are powered by a wood chip generator. Christmas tree trimmings and wood chips are stored throughout the year, kept dry under the Yule Forest structures.

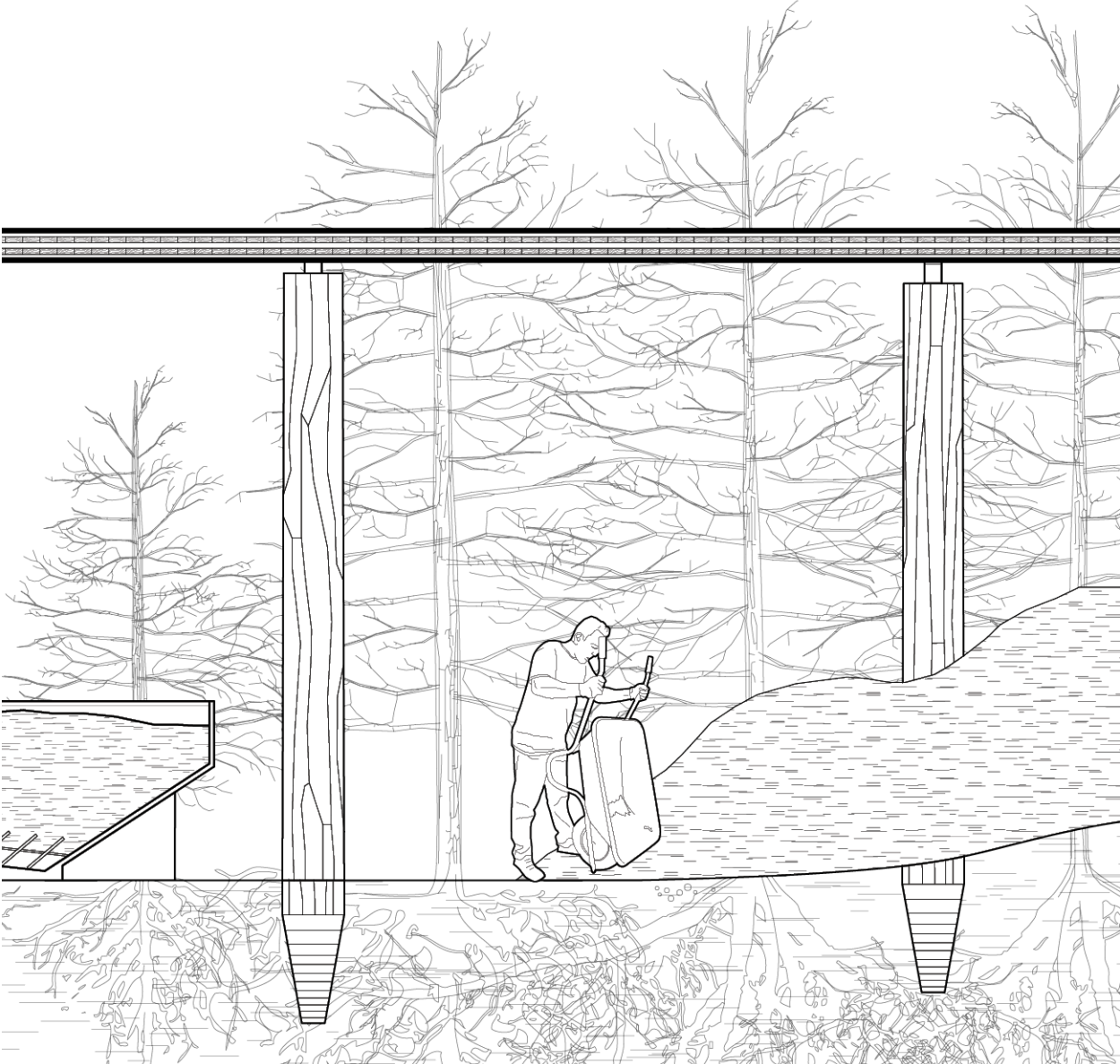

The Camp structure accommodates seasonal forest residents and visitors for the yearly burning.

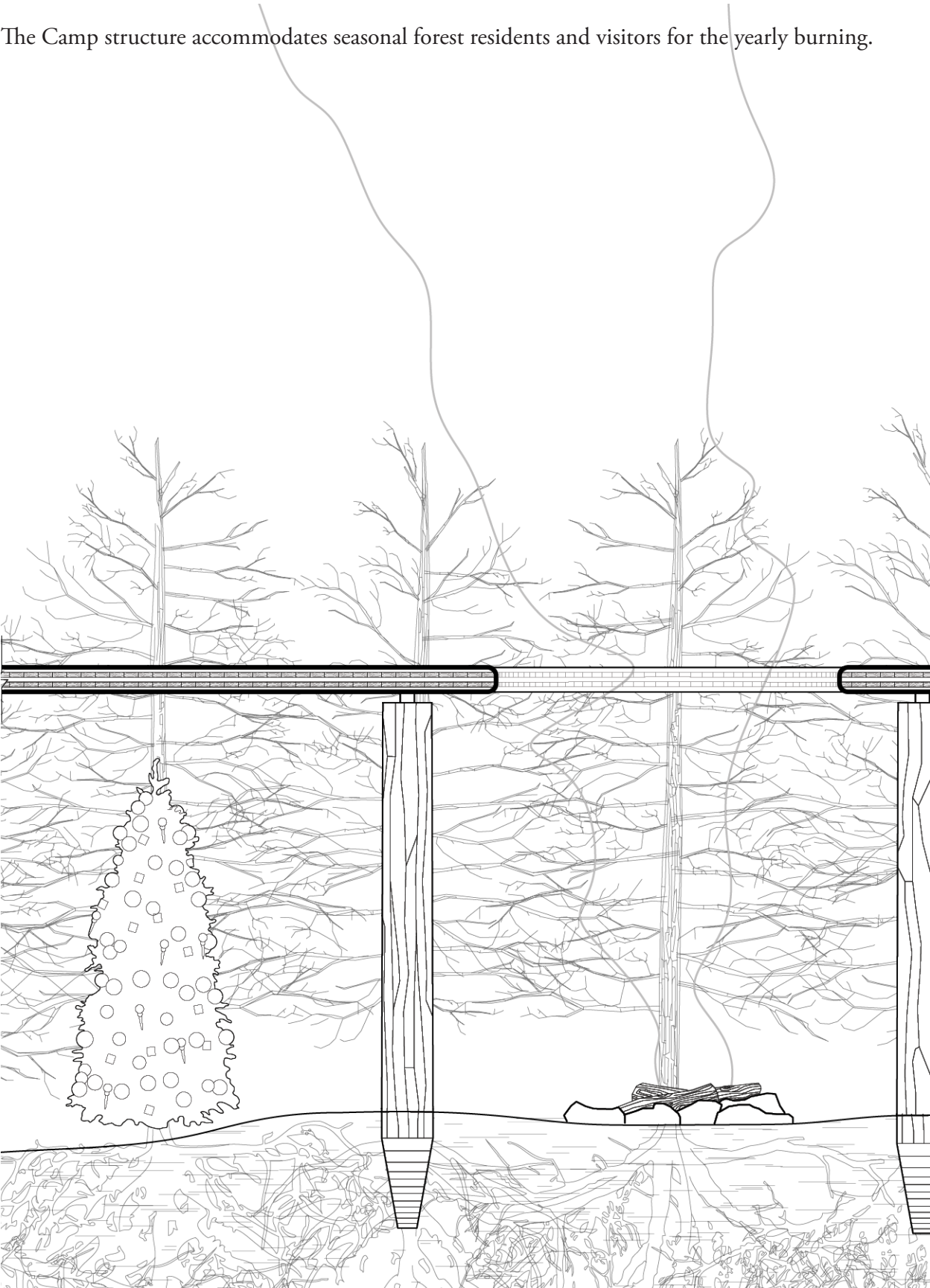

Both the Nursery and Camp structures are constructed raw timber and CLT, oversized and rounded, in order to accommodate the buildup of a protective char layer while maintaining structural stability.



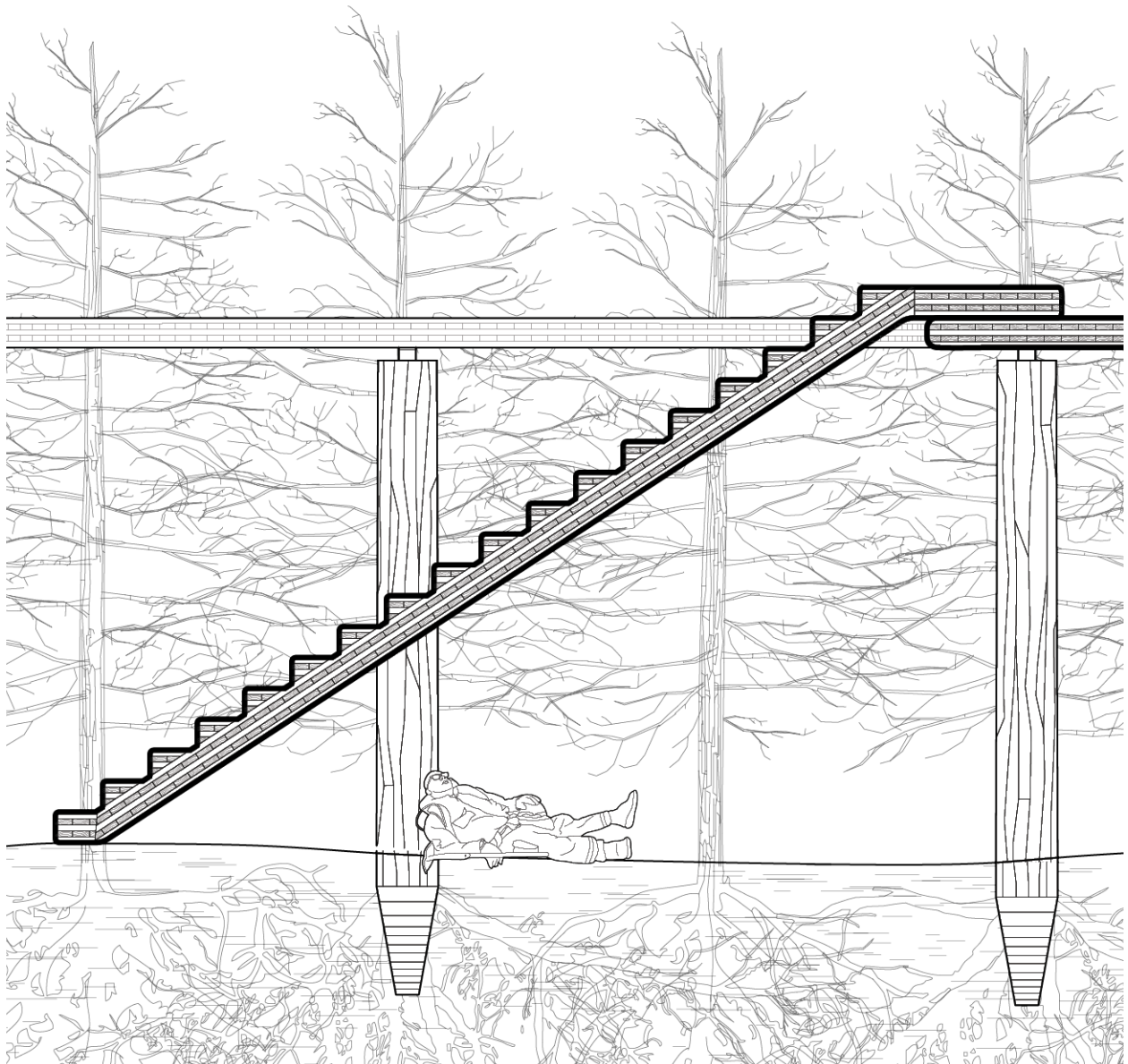

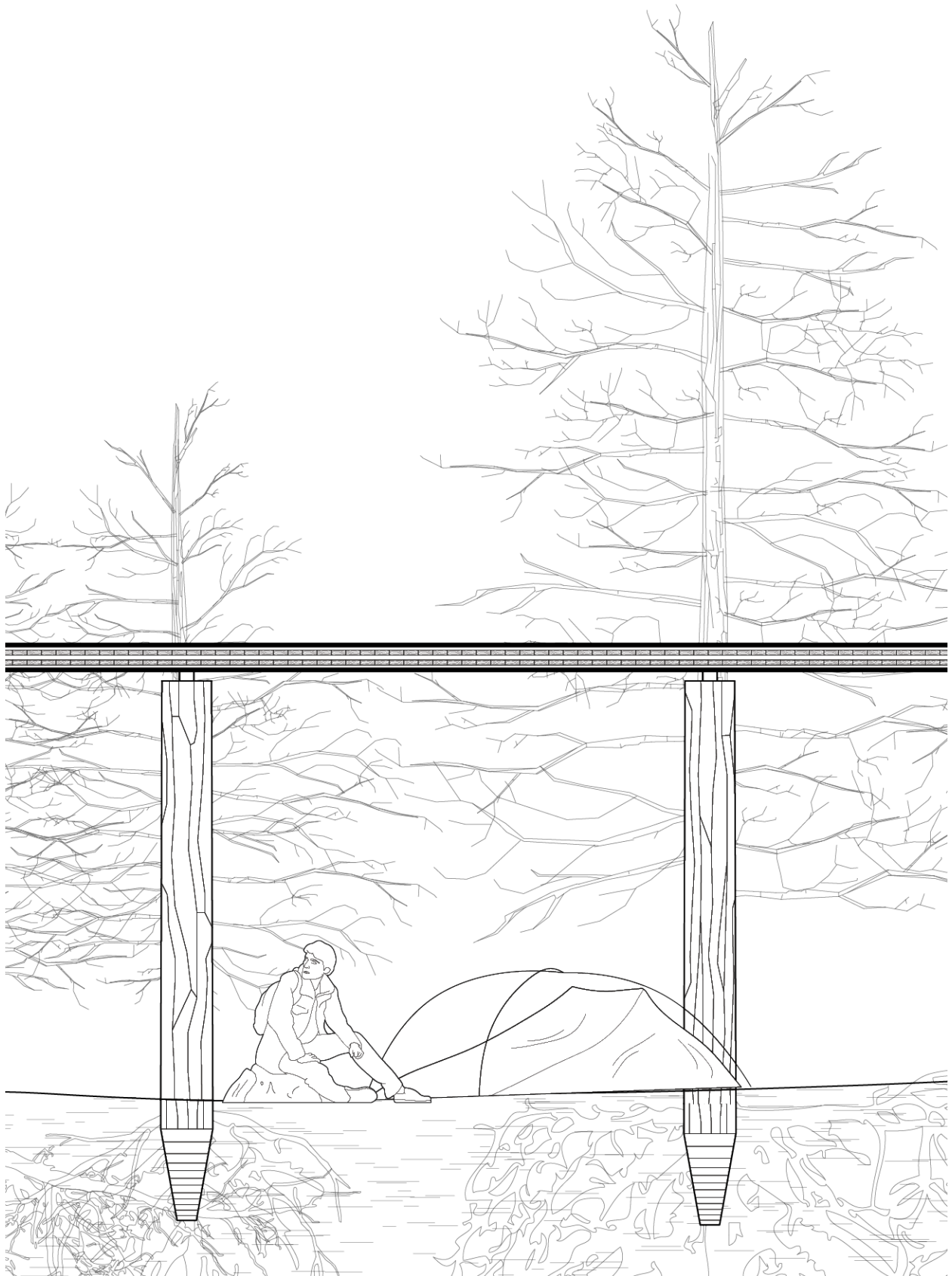

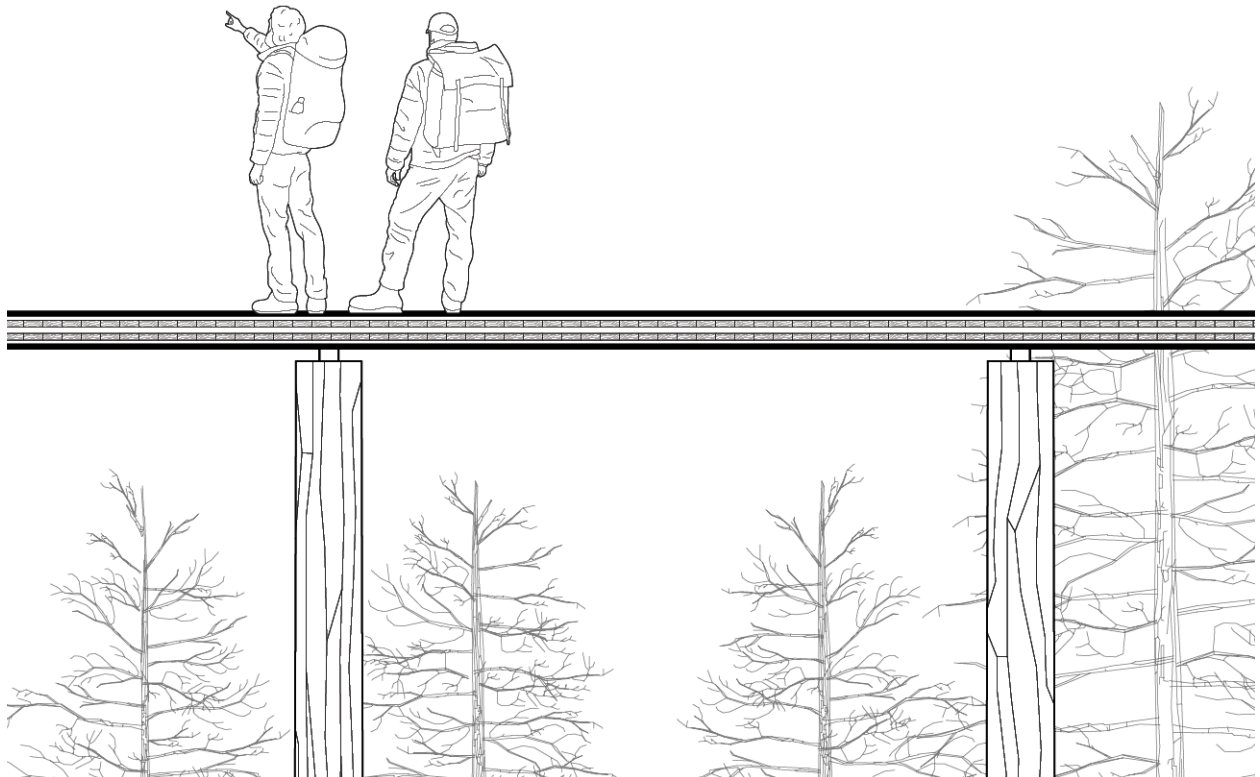

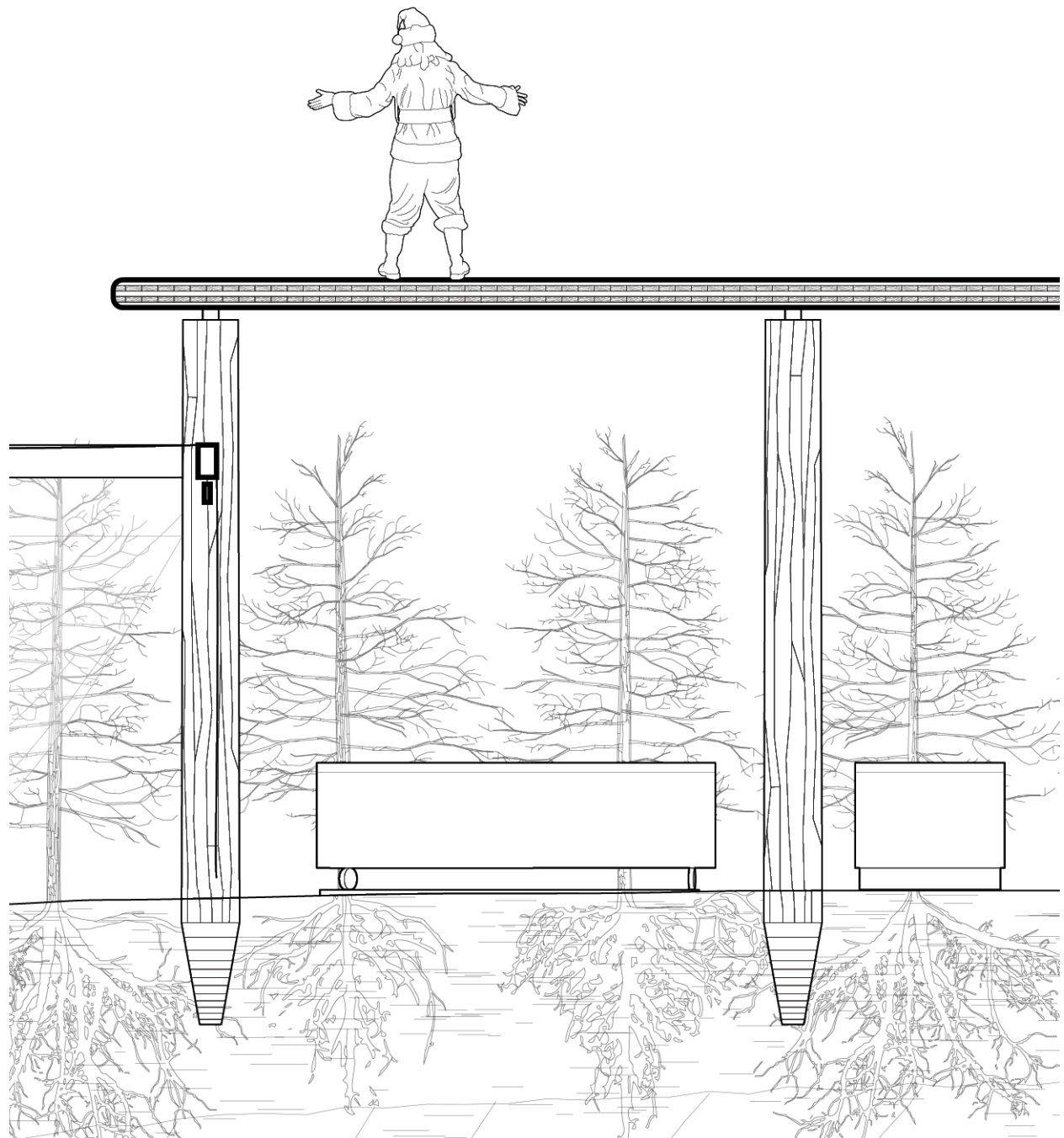

The Yule Log Farm builds upon the everyday tree worship practices of Americans. The ritual of bringing a tree into the house is augmented with new forest rituals.

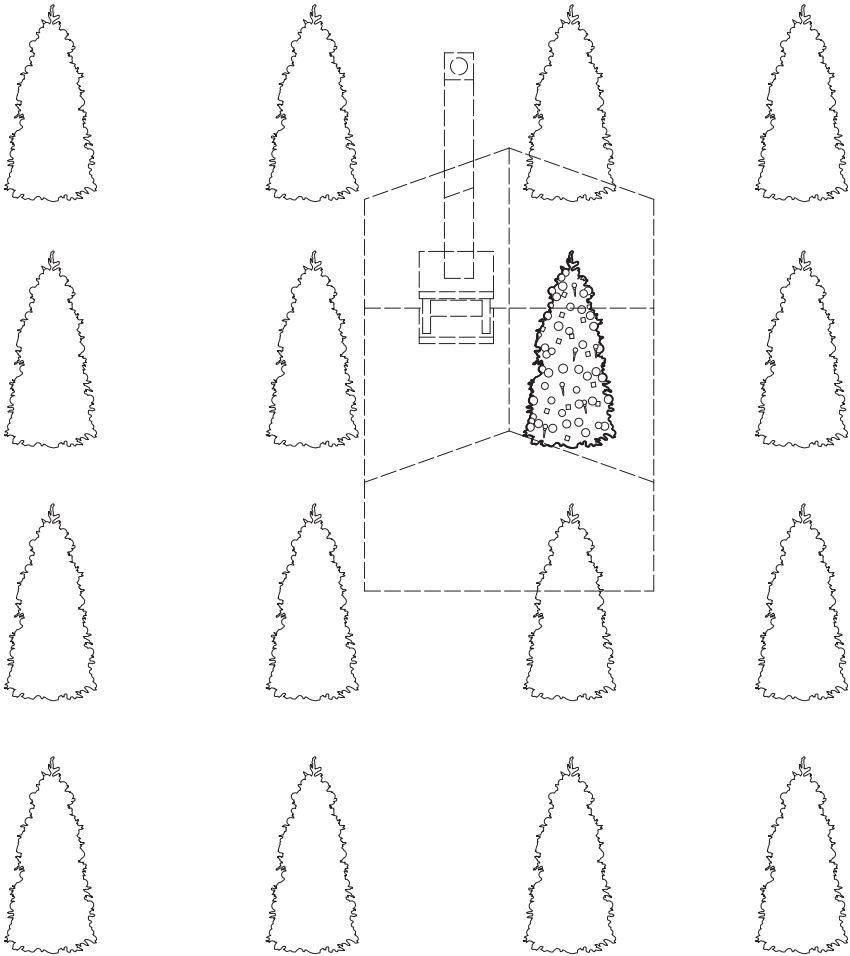









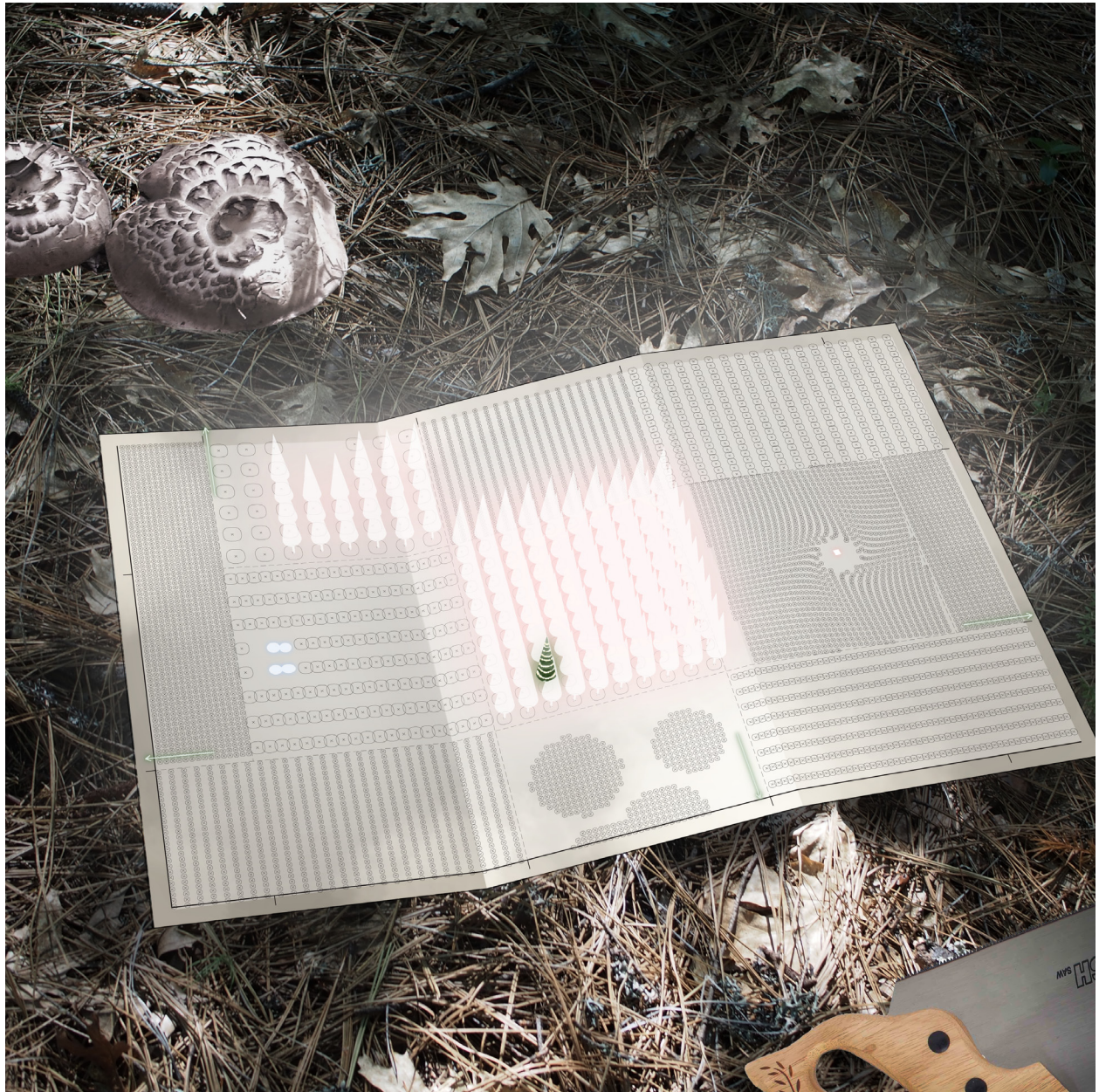



The history of National Forests has often been posed as a struggle - between extraction and conservation, between fire and people. However, Forest Futures proposes new directions by recognizing the existing human interactions with the forest and designing within cyclical fire regimes. The project looks for architectural opportunities within multiple uses, overlap of people and nature, fire. It is the hope that by seriously considering the forest as a site of inspiration and architectural intervention, the forest will regain its importance as a significant human institution.

Appendix A

THESIS DEFENSE



photo courtesy of Sarah Wagner







Appendix B

MENDOCINO CONSERVATION TOWERS

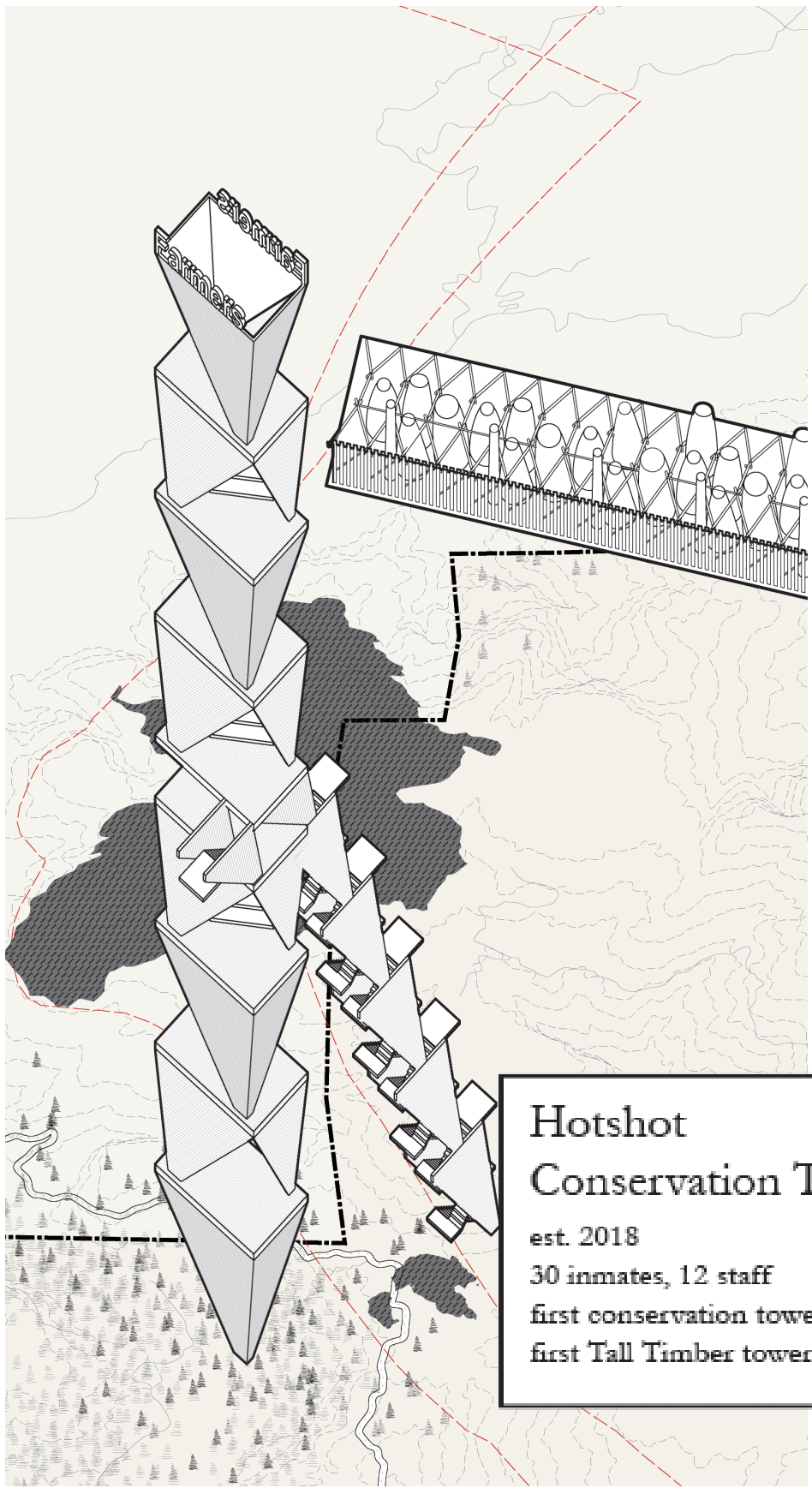

Hotshot Conservation Tower

est. 2018

30 inmates, 12 staff

first conservation tower

first Tall Timber tower over 200'

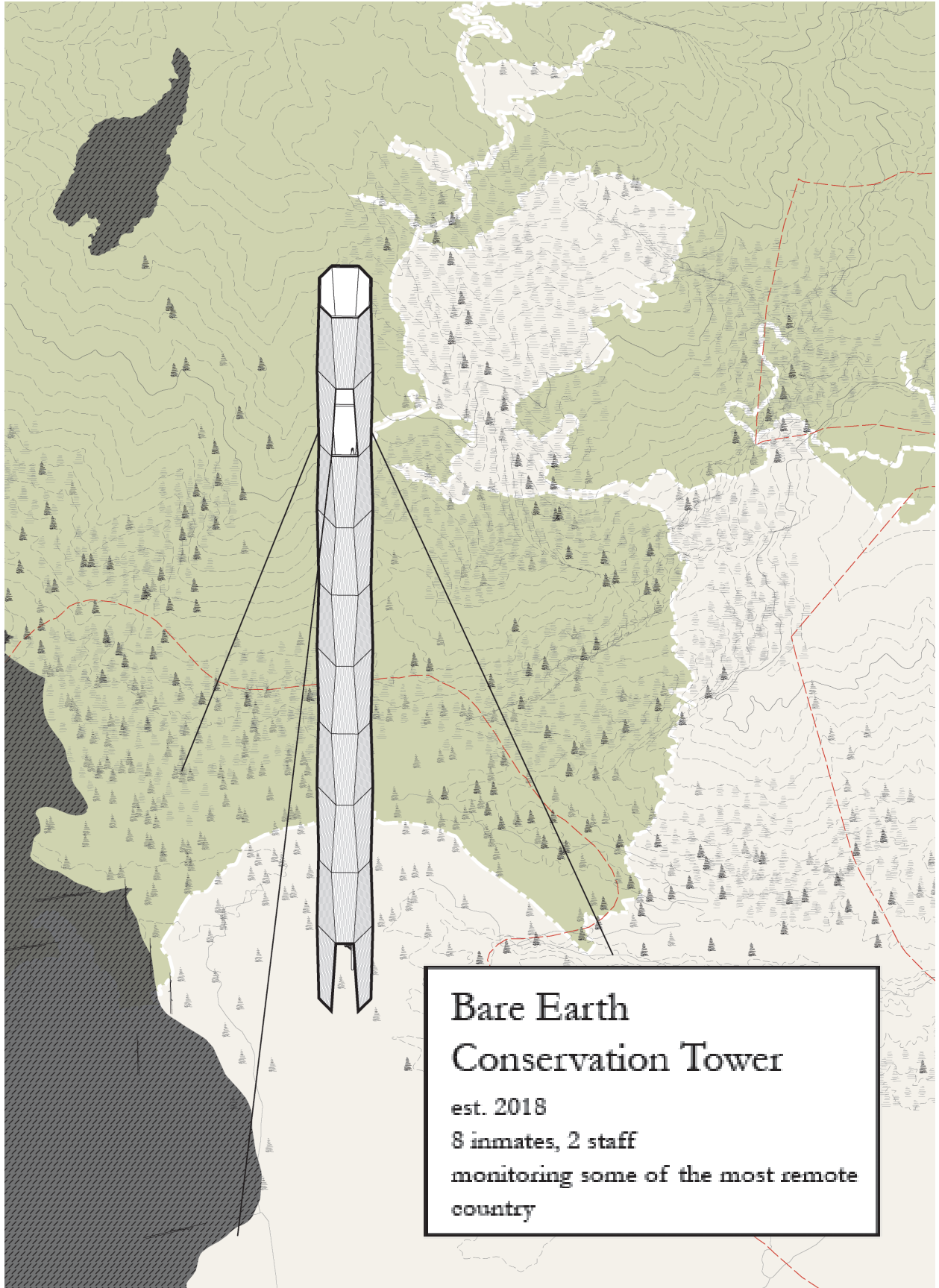

Bare Earth Conservation Tower

est. 2018

8 inmates, 2 staff

monitoring some of the most remote
country

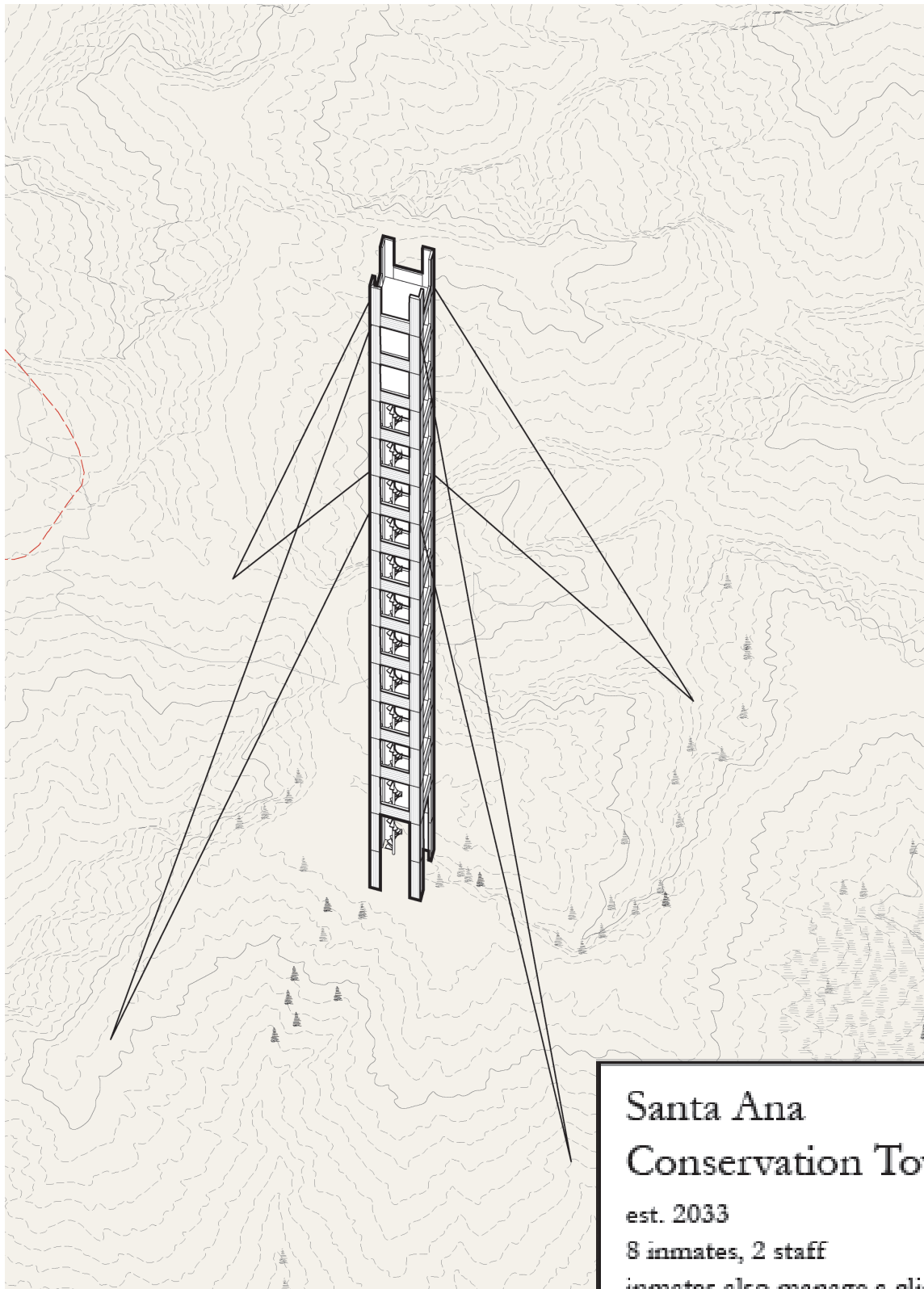

Santa Ana Conservation Tower

est. 2033

8 inmates, 2 staff

inmates also manage a climate data
gathering outpost

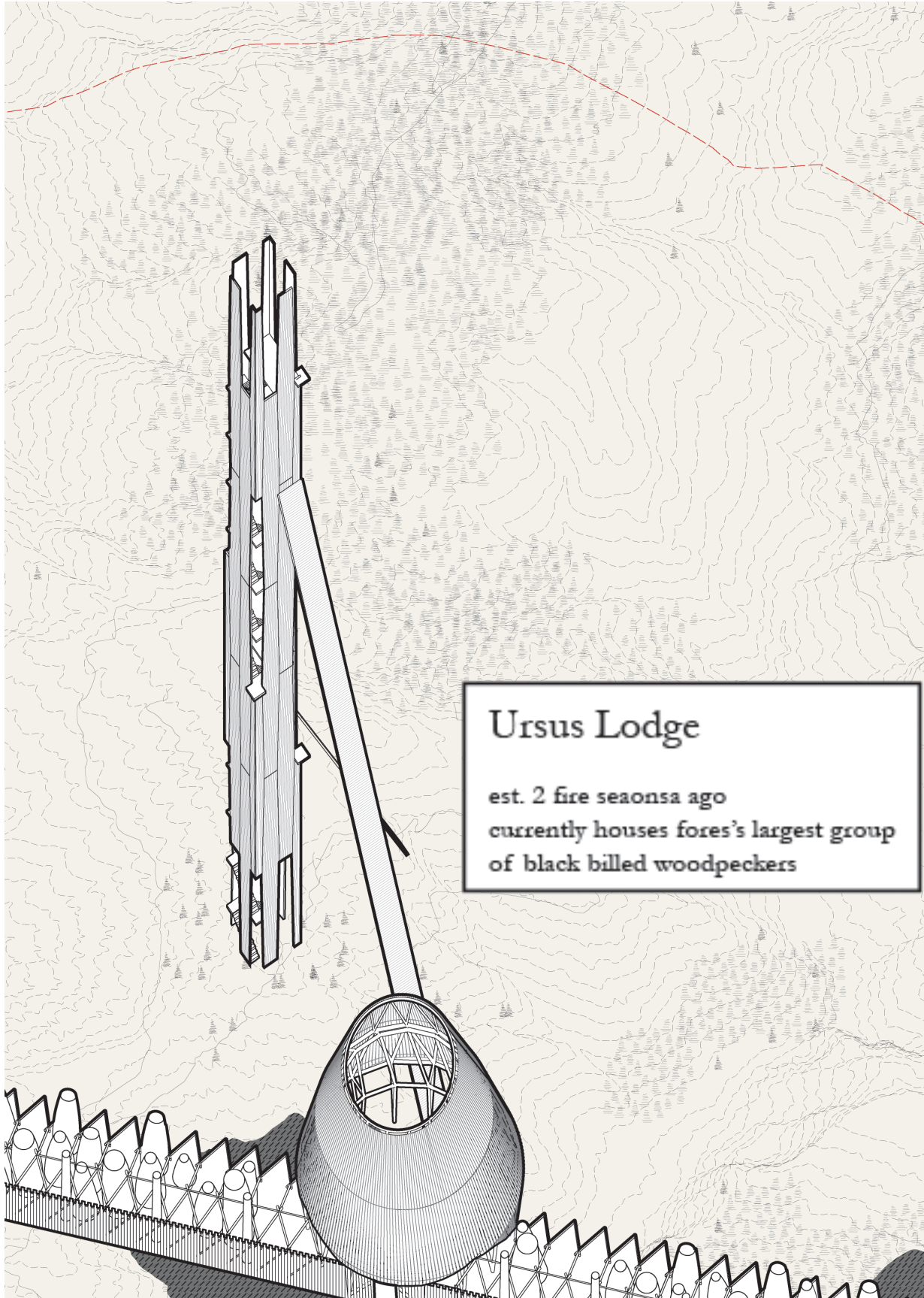

Ursus Lodge
est. 2 fire seasons ago
currently houses forest's largest group
of black billed woodpeckers

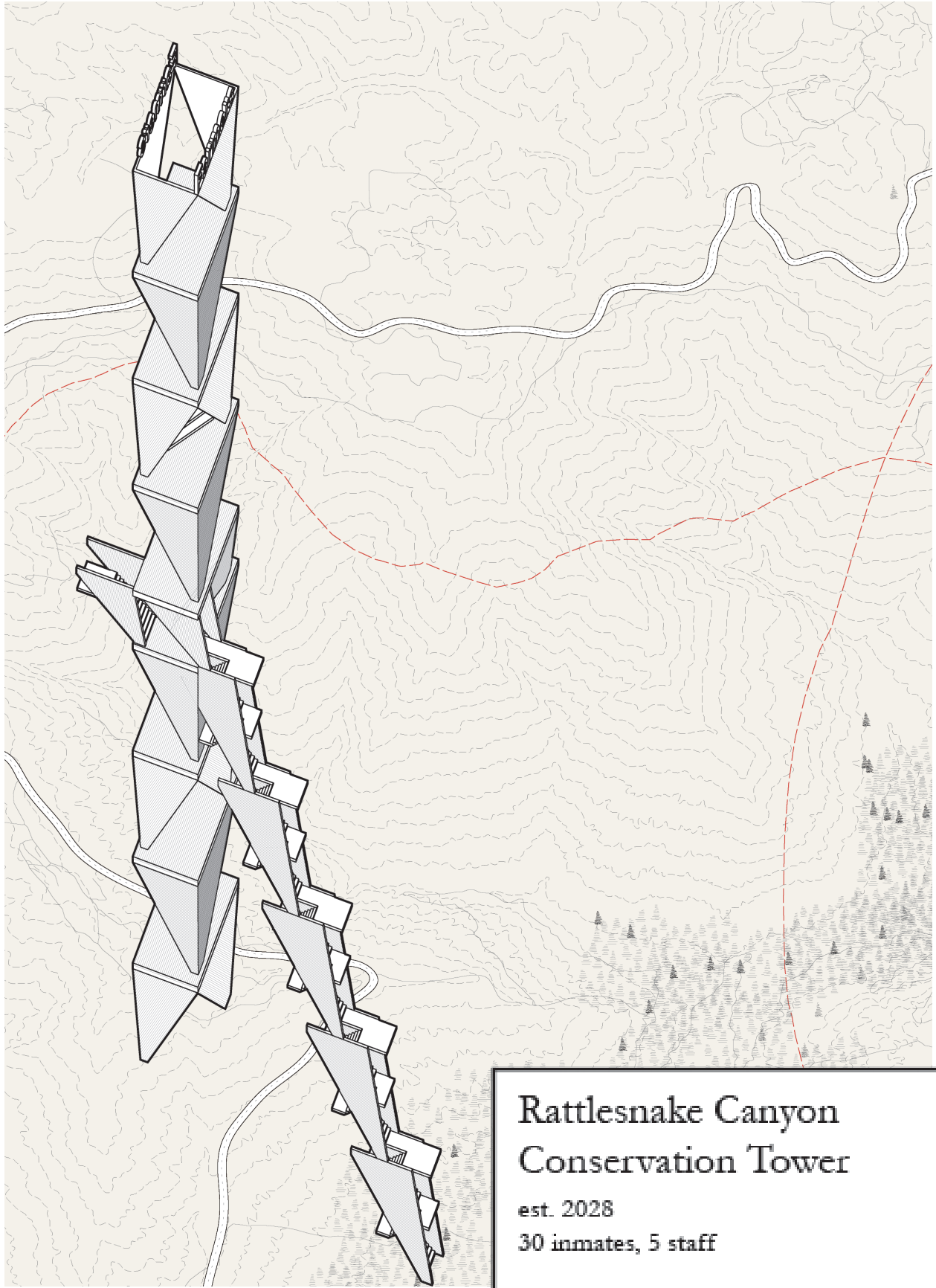

**Rattlesnake Canyon
Conservation Tower**
est. 2028
30 inmates, 5 staff

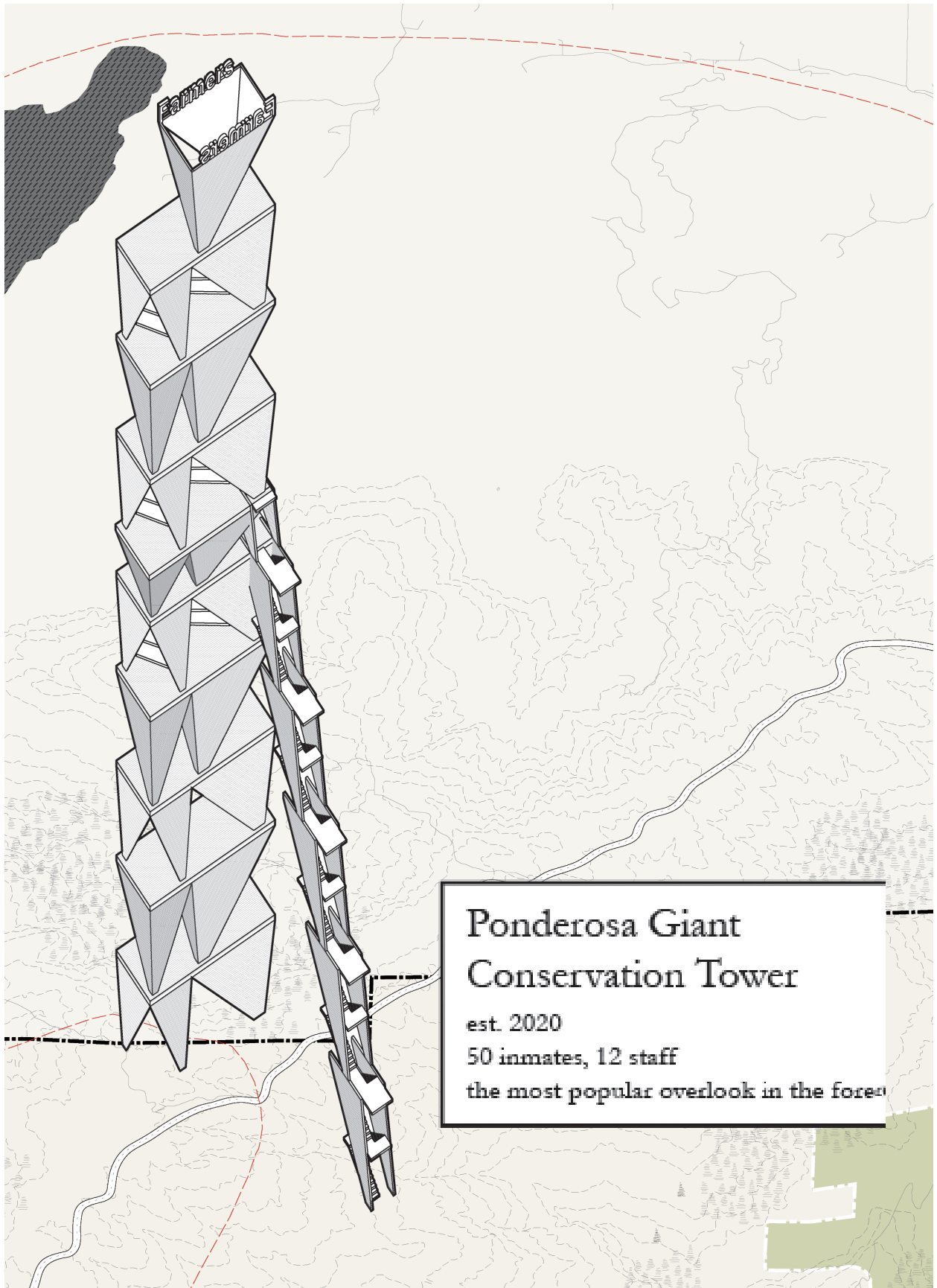

Ponderosa Giant Conservation Tower

est. 2020

50 inmates, 12 staff

the most popular overlook in the forest

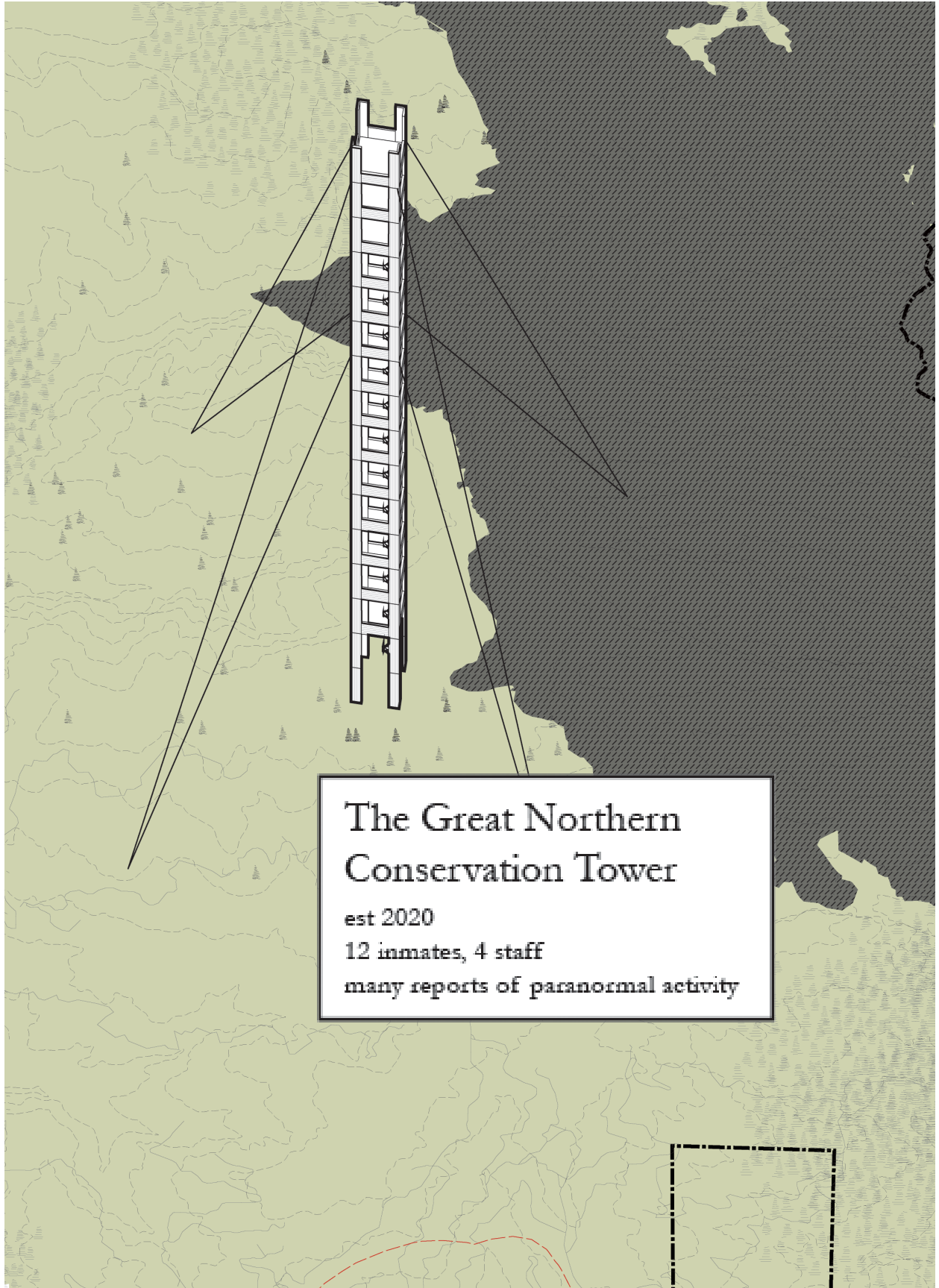

The Great Northern Conservation Tower

est 2020

12 inmates, 4 staff

many reports of paranormal activity



**Gifford Pinchot
Conservation Tower**
to be completed 2030

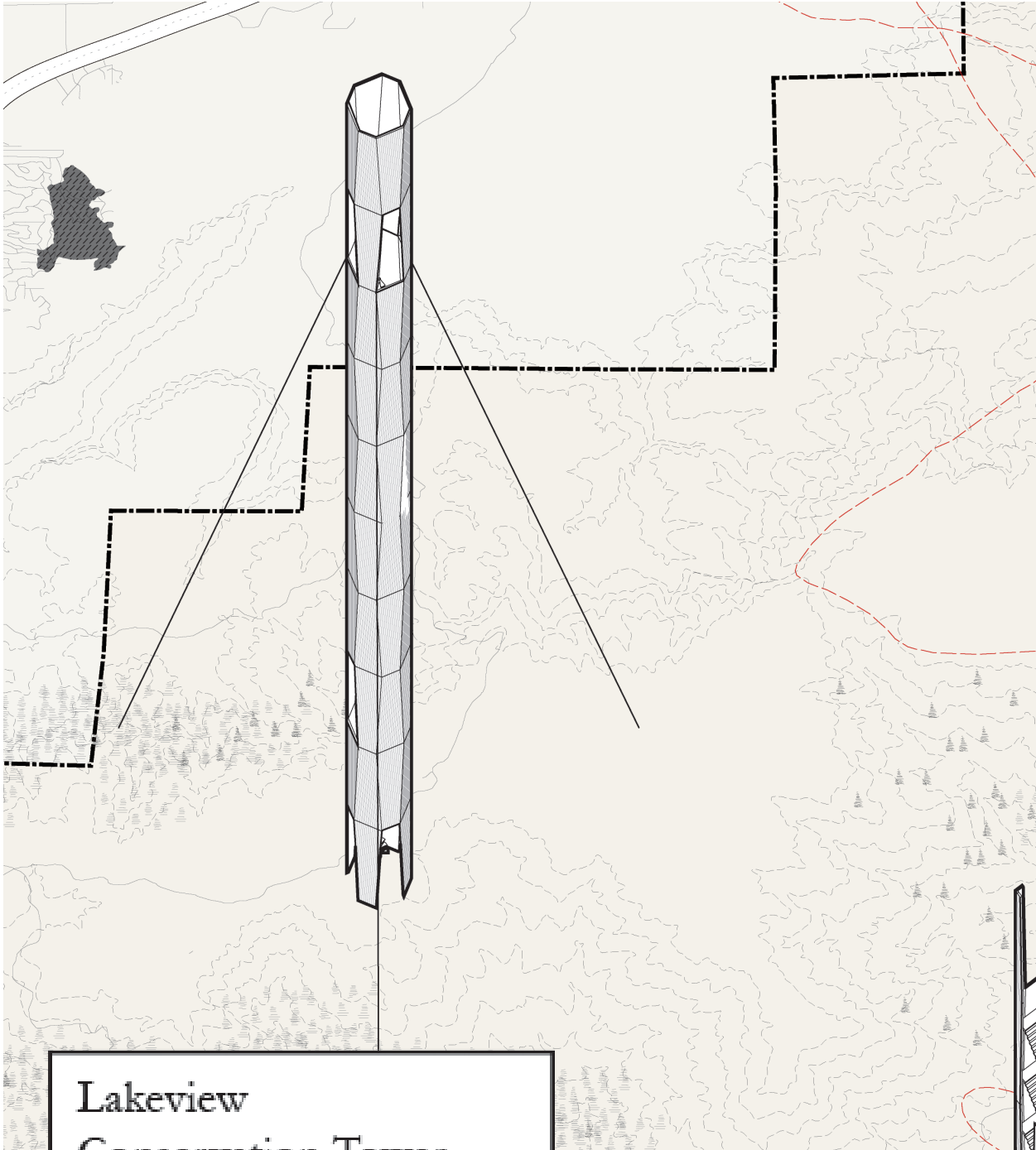

Lakeview
Conservation Tower
est. 2018
10 inmates, 3 staff
the guardian of Clear Lake

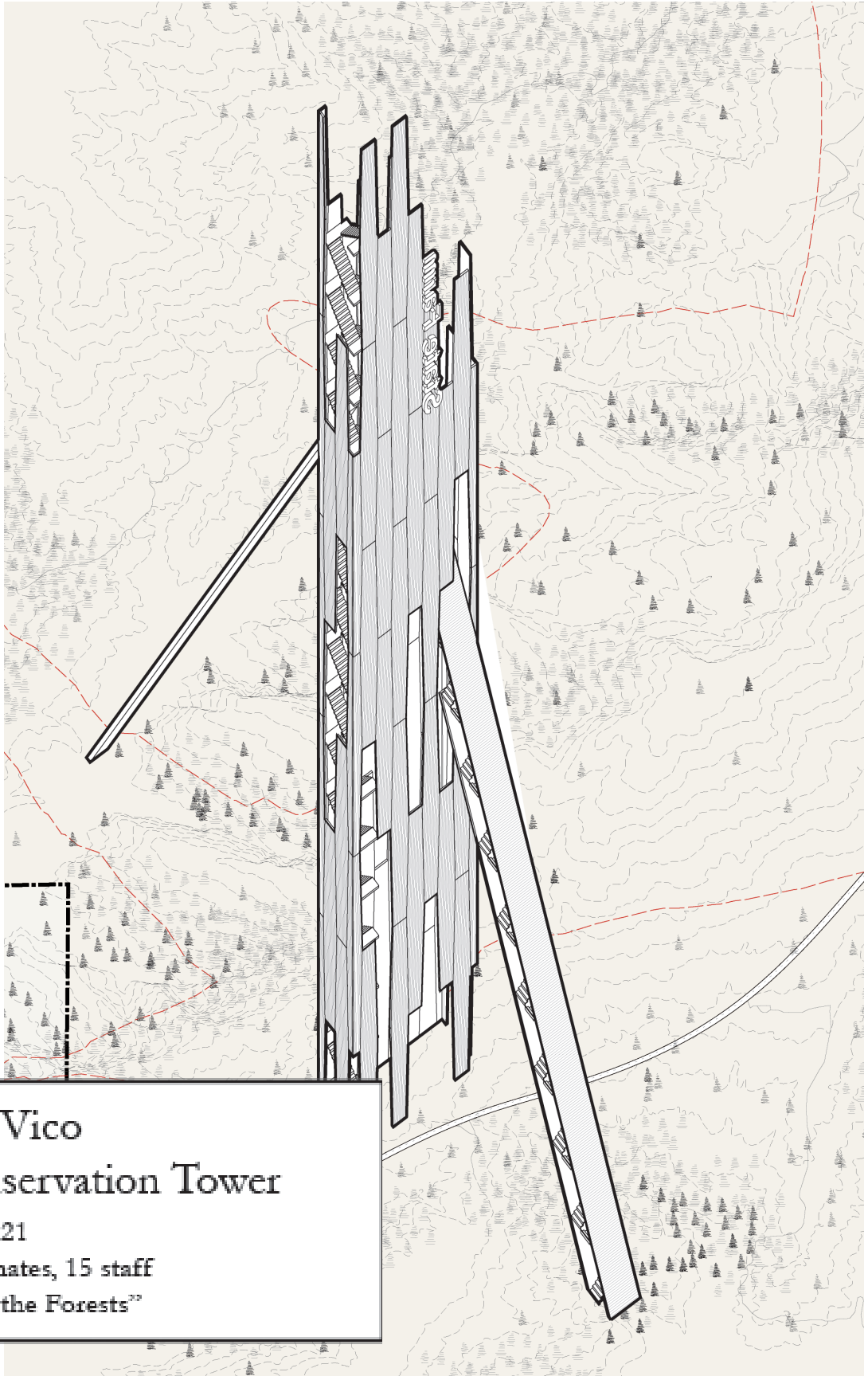

GB Vico Conservation Tower

est. 2021

80 inmates, 15 staff

"First the Forests"

Appendix C

MENDOCINO NATIONAL FOREST RESEARCH AND MAPS

Mendocino National Forest and recent wildfire

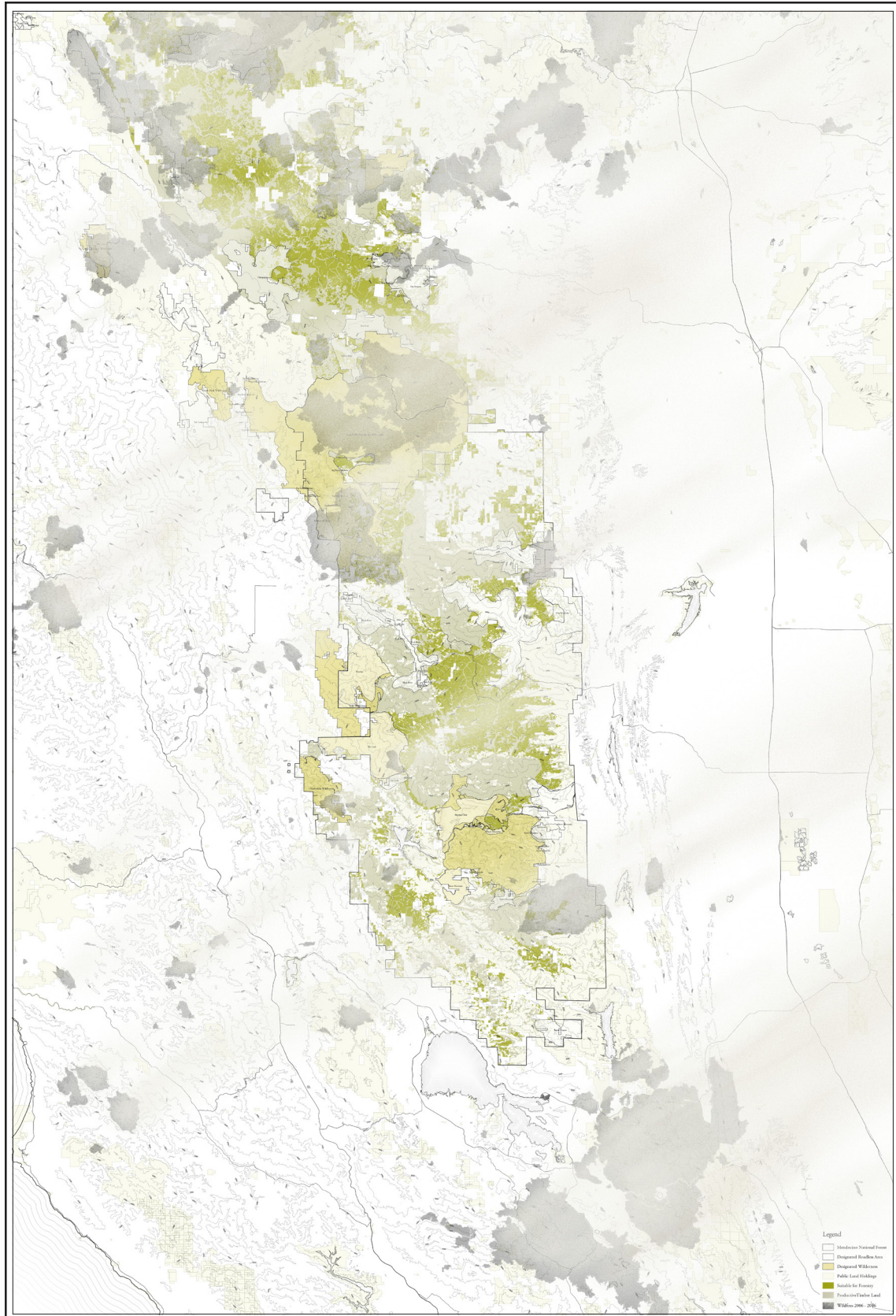

NATIONAL FOREST PRIMER

The USDA Forest Service began in 1905 and today manages 193 million acres of land.

The original mission has expanded beyond preserving timber resources and watershed protection to include conservation, ecological, and recreational uses. While often adjacent to National Parks, National Forests differ greatly in their philosophy of management. National Forests welcome responsible extraction and the interaction of human and natural systems. Its slogan is “Land of Many Uses” as opposed to the National Park’s “Take only Photographs, Leave only Footprints.”

The National Forest project has been one of the most popular American experiments in collective ownership and management. Today, the park faces several challenges including threats of privatization, reduced funding, and an outdated mission statement.

The mission of the USDA Forest Service has been shaped by legislation. National forests were first introduced in 1891 primarily to protect timber resources, game habitat, and watershed. They were initially planned in response to irresponsible private logging and fears of a “timber famine.”

The first Forest Service director, Gifford Pinchot, directly rejected the idea of forests as ecological or recreational areas. However, through legislation and changing views on the values of public forests, the National Forests

today offer a renewed potential for other uses that directly engage the public.

Recent decades have seen two significant changes in the management of national forests. The first is the reduced role of timber extraction as a viable use and the growing importance of recreation and conservation uses. Timber production from National Forests peaked in the 1980’s and provided 83% of America’s timber. Currently, the gross and proportional share of timber production has fallen drastically and National Forests now provide only 2% of all American timber.

The second management challenge is the growing difficulty in fire prevention and suppression. Years of aggressive fire suppression have created dangerous fuel build-up conditions in many of the forests. This, along with the expansion of suburban communities near national forests has created a dangerous and costly situation. Fire management now consumes more than 50% of the department’s budget.

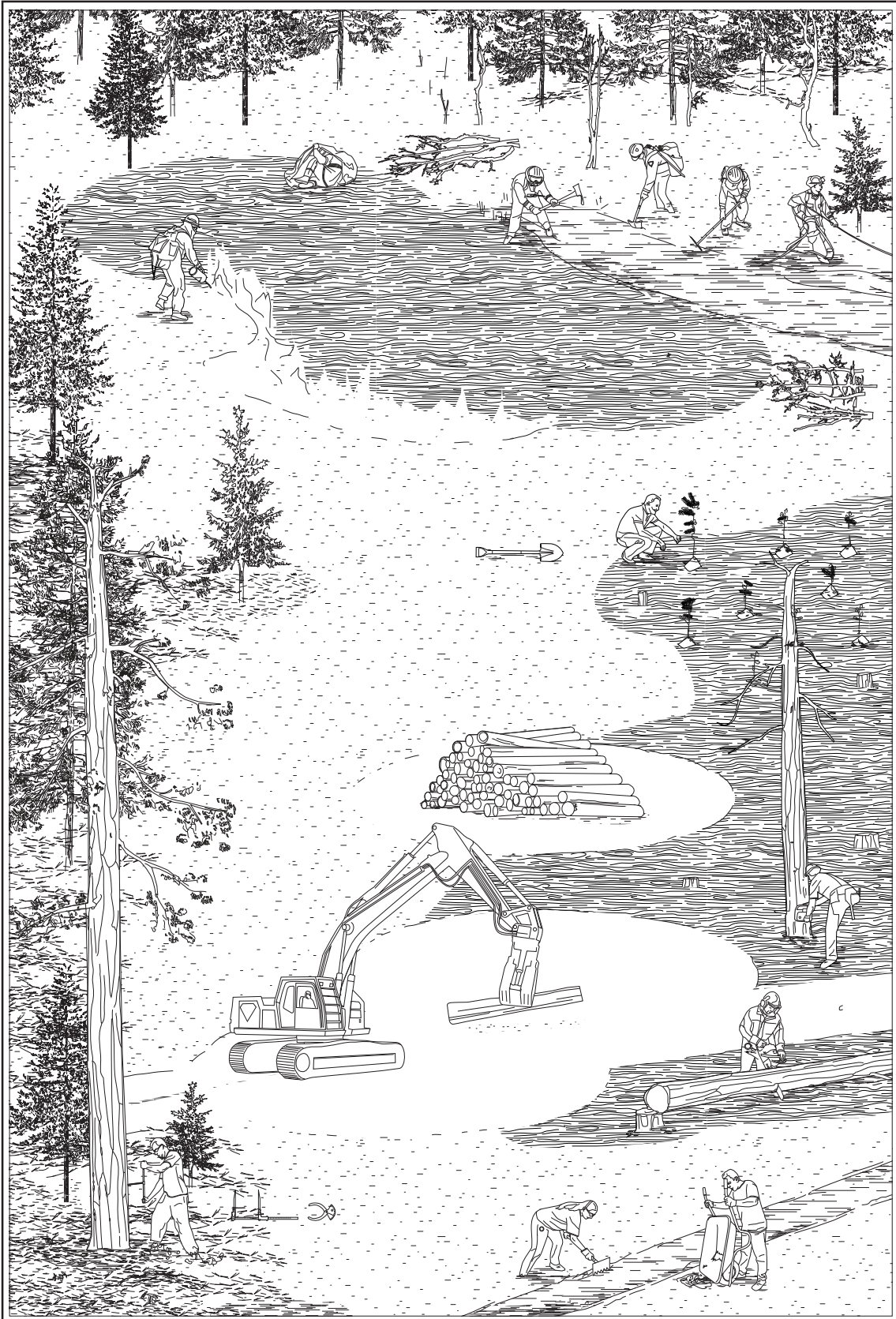

FOREST TOOLS AND TECHNIQUES

Fig. 1

A forester from UC Davis studying the impact of climate change on forest composition takes tree ring core samples with an Increment Borer from a Ponderosa Pine specimen. He also carries tree calipers to measure the diameter of the trunk, measured at chest height.

Fig. 2

Two Californian Conservation Corps members repair a nature trail in the forest. Using a McLeod Fire Line Tool and a wheelbarrow, the corpsies remove encroaching vegetation and deposit gravel. The McLeod was invented in 1905 by US Forest Ranger Malcolm McLeod to rake fire lines, but has proved a versatile tool.

Fig. 3

After a recent burn, two salvage loggers remove dead, but still usable, timber from the forest. They utilize chain saws, their personal protective equipment, and a skidder to cut and move the logs. Salvage logging often occurs after burns or bark beetle infestations, yet is controversial because it has minimal ecological function.

Fig. 4

Three inmate firefighters, in a cooperative effort between the California Department of Corrections and CalFire, create a fire break using a McLeod, combination pick/shovel, and Pulaski (a combination axe/adze invented by forest ranger Ed Pulaski in 1911).

Fig. 5

A fifth firefighter enters his emergency fire shelter. Carried by every backcountry fire fighter since 1977, these have save hundreds of fire fighters lives from short-lived fire. Currently, NASA is working with the USFS to develop more secure shelters. In addition to protecting against extreme heat and hazardous gasses, the shelters must be extremely light and portable.

Fig. 6

A USFS ranger uses a shovel to plant tree saplings in an experimental forest north of Mendocino National Forest. The ranger , in collaboration with a research university, is testing the viability of new tree species in this climate.

Fig. 7

Prescribed burns are used for ecological and fire prevention purposes. Here, a forest ranger uses a drip torch to start a controlled burn. The burn will clear built up fuel and stimulate the germination of Lodgepole pines.

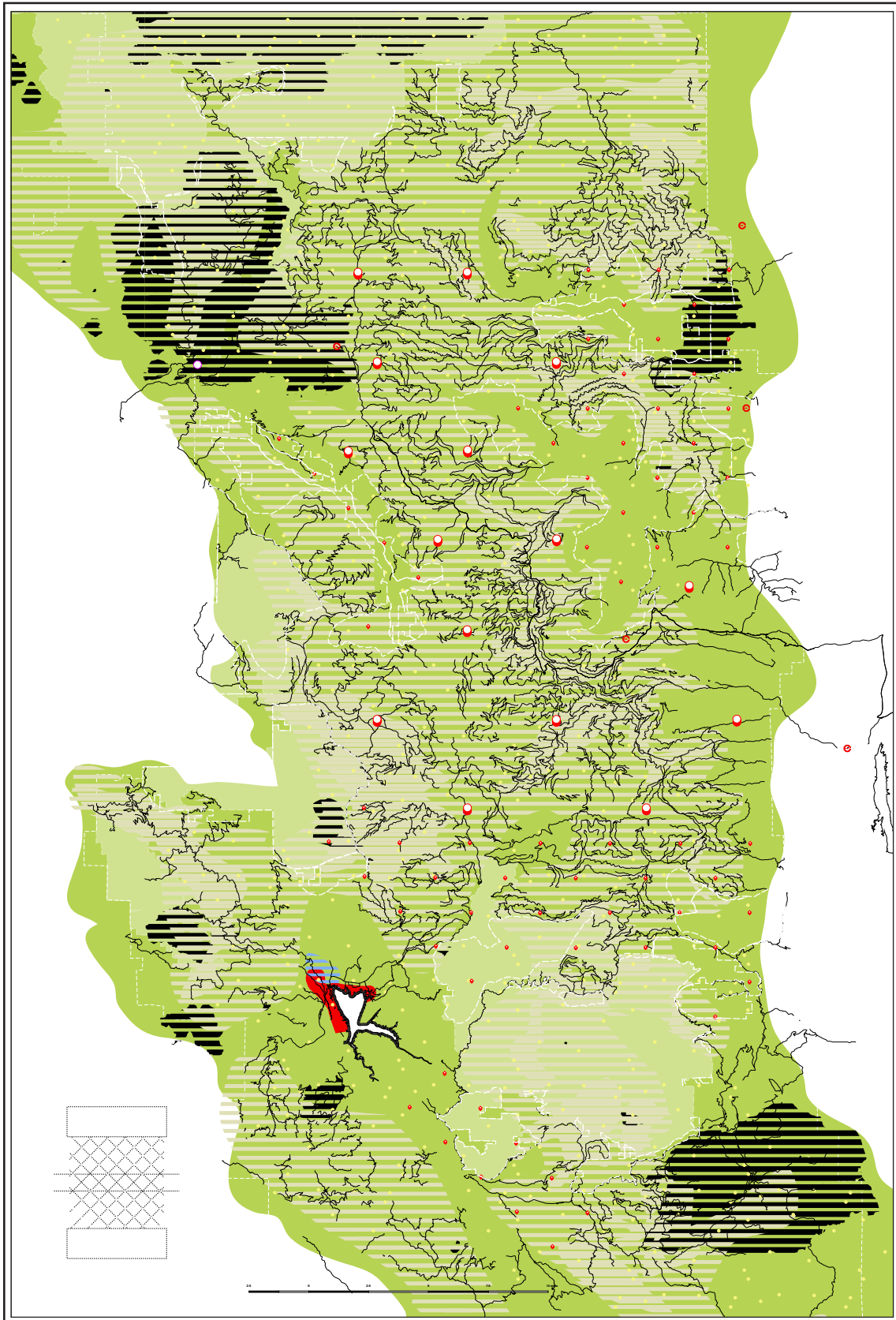

FOREST ACTORS



Human

Mendocino NF is home to 300 permanent residents, with second homes hosting 400 more, and marked campsites hosting up to 800 people a night. 250 residents are male California Department of Corrections inmates and their CalFire supervisors living in two wildfire Conservation Camps. Other visitors come for hiking, logging, hunting, mushroom foraging, water activities, shooting, and camping.



Pinus ponderosa

This large pine makes up much of the mixed-conifer forest of Mendocino National Forest. The largest of the species can grow 260' tall and 100" in diameter. In natural states, low intensity fires burn through pine forests every 5 - 10 years. Pine trees in California are currently being decimated due to sustained drought and attack from the Western Pine Beetle. An estimated 100 million pine trees in California have died since 2010.



Dendroctonus ponderosae

The 'Western Pine Beetle' is a bark beetle native to North America. The beetles aggressively attack *Pinus ponderosa* greater than 6" in diameter, and infection is usually fatal for the tree. During drought periods pine trees are especially vulnerable. Canada and the western United States are currently experiencing severe tree mortality rates due to bark beetle infestation, and standing dead trees increase fire danger.



Cervus canadensis nannodes

The 'Tule Elk' is one of two sub-species of elk native to California, and a protected species. Pressure from hunting and competition with livestock on grazing lands brought Tule Elk almost to extinction in the 1800's. The Lake Pillsbury Basin in Mendocino National Forest is home to 100 reintroduced elk.



Morchella

Morels are a genus of fungi prized for their edibility. Unable to be cultivated, these fungi are harvested in the wild and especially numerous the year after a major burn. Morels form symbiotic relationships with coniferous trees. Commercial pickers often locate sites of wildfires to collect and bring to market bumper crops, for a healthy profit.



Ursus americanus californiensis

California is home to 30,000 black bears. A small species of bear, Black Bears have better eyesight, hearing, and a significantly better sense of smell than humans. The bears are territorial, marking trees to define their territory, and climbing them to feed or hibernate. Up to 1,700 bears are hunted in California every year, with several permits issued for Mendocino NF.A



MENDOCINO NATIONAL FOREST

MNF is a large forest of 1 million acres located 3 hours north of San Francisco. The park forms the southern tip of a string of National Forests and Parks extending from the Pacific Northwest. Despite its proximity to San Francisco and Sacramento, the forest remains one of the least visited forests because of its lack of roads. Many of the visitors who do come, come to shoot, hunt, drive Off Road Vehicles, and fish. There are also active timber operations within the park.

SUITABLE TIMBERLANDS

Much of the MNF is comprised of productive timberlands. However, more than half of those lands are protected from logging by the Roadless Area Rule and Wilderness Designation. Most of the current logging operations are salvage operations, logging trees damaged by fire or pests. There are currently plans for thinning logging in many parts of the forest.

WILDFIRES

MNF and the surrounding area sees frequent wildfires. Most are actively fought by the California Dept of Corrections inmate firefighting force and CAL FIRE, however, small burns in wilderness areas are often let on their own. As of Sept 14, 2017, there were 5 concurrent fires within forest boundaries. 3 were being actively fought with smokejumpers, 100 firefighters, 4 bulldozers, 19 engines, and 5 water tender.



Timberlands



Roadless Area



*Designated
Wilderness*

TIMBERLANDS

The majority of land in the National Forest system is managed under the 1960 Sustained-Yield and Multiple-Use Act which mandated management for the three interests of production, conservation, and recreation, and the “achievement and maintenance of a high-level regular output of the renewable resources of the national forest without impairment of the lands productivity”

ROADLESS AREA

The hotly contested Roadless Area Conservation Rule of 2001 gave regional forest departments the ability to designate land as “roadless.” Currently, it prohibits “road construction, road reconstruction, and timber harvesting” on 58.5 million acres (roughly 1/3rd) of the National Forest system. The presiding judge in the deciding 2011 court case determined that the Roadless Areas were **not** “de-facto wilderness,” to the chagrin of many logging companies.

DESIGNATED WILDERNESS

Defined by the Wilderness Act of 1964, Wilderness areas, as defined by US Congress, are “in contrast with those areas where man and his own works dominate the landscape, is hereby recognized as an area where the earth and its community of life are untrammelled by man, where man himself is a visitor who does not remain ...” Mechanical devices, logging, grazing, and mining are prohibited

bibliography

Anna-Sophie Springer and Etienne Turpin, ed, *Land & Animal & Nonhuman*,
intercalculations 2

Anna-Sophie Springer and Etienne Turpin, ed, *The Word for World is Still Forest*,
intercalculations 3

Anna Tsing, *The Mushroom at the End of the World* (2015)

Bruno Latour, "Agency at the time of the Anthropocene," *New Literary History* Vol.
45, 2014: 1-18

Detlef Mertin, "Living in a Jungle: Mies, Organic Architecture, and the Art of City
Building," *Mies in America*

Donna Haraway, *Staying with the Trouble: Making Kin in the Chthulucene*,
Durham: Duke University Press, 2016

Eduardo Kohn, *How Forests Think: Toward an Anthropology beyond the Human*

Etienne Turpin, ed, *Architecture in the Anthropocene*

James Corner, *Taking Measure of the American Landscape*

Neil Brenner and Christian Schmid, *Implosions/Explosions: Towards a Study of
Planetary Urbanization* (Jovis Verlag, 2014)

Rafi Segal, "Urbanism without Density," in *Architectural Design: Diffuse Urbansim*
Vol. 78 No.1 (2008)

Reyner Banham, *Los Angeles: The Architecture of Four Ecologies* (Harper &
Row, 1971)

Robert Harrison, *Forests: The Shadow of Civilization* (1992)

Simon Schama, *Landscape and Memory* (Alfred A Knoff, 1995)

Ursula K. Le Guin , "A Non-Euclidean View of California as a Cold Place to be,"
Dancing at the Edge of the World (1982)

Ursula K. Le Guin, *The Word for World is Forest* (1976)