

METHODOLOGY IN ARCHITECTURAL DESIGN

by Glenn E. Wiggins
Bachelor of Architecture
Texas Tech University
Lubbock, Texas

Submitted to the Department of Architecture
in partial fulfillment of the
requirements of the degree
Master of Science in Architecture Studies

at the
MASSACHUSETTS INSTITUTE OF TECHNOLOGY
June, 1989

© Glenn E. Wiggins 1989. All rights reserved.

The author hereby grants to M.I.T. permission
to reproduce and to distribute copies of this
thesis document in whole or in part

Signature of Author: _____
Glenn E. Wiggins, Department of Architecture
11 May 1989

Certified by: _____
Donald A Schön
Ford Professor of Urban Studies and Education
Thesis Supervisor

Accepted by: _____
Julian Beinart
Chairman, Departmental Committee for Graduate Students

MASSACHUSETTS INSTITUTE
OF TECHNOLOGY

JUN 02 1989

LIBRARIES
DATCH

METHODOLOGY IN ARCHITECTURAL DESIGN

by Glenn E. Wiggins

Submitted to the Department of Architecture
on 11 May 1989 in partial fulfillment
of the requirements of the degree
Master of Science in Architecture Studies

ABSTRACT

The act of designing in architecture is a complex process. Many designers, when probed for reasons to explain their actions, are either unable to answer questions, or provide explanations that are not true descriptions of their actions. Frequently the designer will answer that his or her reason for making a particular design decision is based on 'feeling' or 'intuition.'

Under this model the design process assumes a 'mystical' aura. Architectural designers can create, yet are unable to say how they do so. Often that which can be explicitly discussed by the designer is the least significant part of his or her design process. It is unlikely that designers are 'channeling' information from cosmic sources. Rather, they are working with knowledge that is largely tacit.

This thesis attempts to de-mystify the process of architectural design. Through a close scrutiny of existing literature, incorporation of personal experience as an architect, and testing of theories with lay, novice, and expert designers a theory of design methodology is proposed.

Thesis Supervisor: Donald A. Schön

Title: Ford Professor of Urban Studies and Education

Table of Contents

• Table of Contents.....	3
• Acknowledgments.....	5
• Introduction	
Why Study Design Methodology	
Understanding Structures of Design Knowledge.....	6
The Need for Explicit Language.....	7
Computational Models.....	8
Structure of Thesis.....	8
• A Design Methodology	
Design Worlds.....	10
Substantive Knowledge	
Introduction.....	11
Types - Background.....	13
Types - Spatial Gestalts.....	19
Types - Functional Types.....	21
Types - References.....	22
Types - Experiential Archetypes.....	22
Types - Design Icons and Design Canons.....	23
Judgments.....	25
Process Skills	
Introduction.....	28
Designing as a Conversational Process.....	29
The Discovery Process.....	32
Unintended Consequences of Moves.....	33
Lay, Novice, and Expert Designers	
Background.....	36

- **The Cases**
 - Introduction..... 39
 - Case One - Gestalts..... 43
 - Case Two - How Universal Are Types
 - The Jailor's Entrance Exercise..... 52
 - The 'Dream' Library Exercise..... 56
 - Case Three - Rules Derived From Types..... 59
 - Case Four - Discovery and the Seeing-Moving-Seeing Process..... 65
 - Case Five - Protocol Check - The Influence of Sheet Orientation..... 68
 - Case Six - Protocol Check - The Influence of Scale..... 76
 - Case Seven - Miscellaneous..... 82

- **Conclusion**..... 92
 - Conclusions About Design Methodology..... 92
 - Conclusions About the Experimental Method
 - Results From the Exercises..... 96
 - Limitations on Data Imposed by the Experimental Method..... 98
 - Personal Issues Concerning the Experimental Method..... 100
 - Implications and Questions for Further Study..... 102
 - Implications for My Own Practice..... 105

- **Appendix - The Protocols**..... 110
 - Corbin..... 111
 - Darin..... 117
 - Linda..... 130
 - Lora..... 143

- **Bibliography**..... 173

Acknowledgments

Throughout my tenure at MIT I have had the good fortune to study with, and learn from, an inspiring group of students and educators. To all of them my sincere thanks.

I am particularly grateful to Don Schön; first for his theories and teaching which have greatly influenced my attitudes about many ways of learning, and second for his continued support of my research and writing, not only with regard to this thesis, but throughout my entire time at MIT. I am grateful to Julian Beinart and William Porter for their insightful comments on my thesis as well as my other studies at MIT. I am also deeply indebted to Leo Marx who, though not directly involved in the development of this thesis, is a continuing source of inspiration.

I thank the people who participated in the case studies for this thesis: Corbin, Darin, Linda, and Lora. Their willingness to engage in what they viewed as a curious process is appreciated.

Finally, and most significantly, I thank my family.

Introduction

• Why Study Design Methodology

Understanding Structures of Design Knowledge

Many designers believe that a study of the design process will impair their ability to design. They fear that such study will lead to the creation of explicit procedures that will destroy their intuitive creativity and perception. Rudolf Arnheim notes that there is some basis for this fear as history provides many examples that illustrate the destructive potential of formulas. He argues for balance, however, saying:

...are we to conclude that in the field of the arts one power of the mind must be put out of action so that another may function? Is it not true that disturbances occur precisely when any one mental faculty operates at the expense of the other? The delicate balance of all our powers - which alone permits us to live fully and to work well - is upset, not only when the intellect interferes with intuition, but also when feeling dislodges reasoning. An orgy of self-expression is no more productive than blind obedience to rules. Reckless analysis of the self will do harm, but so will the artificial primitivism of the man who refuses to know how and why he works. (Arnheim, 1954)

While there is no doubt that a maniacal reliance on a set of design guidelines can be detrimental, understanding one's structure of design knowledge can be very beneficial to the design process.

During the design process, for example, it is not uncommon for a designer to reach an impasse where he or she has hit a 'dead end' or become 'stuck.' By

understanding the structure of his or her design knowledge, a designer will be well prepared to handle unforeseen problems of this sort. Instead of giving up or accepting a mediocre solution, the designer will be capable of developing alternate strategies which provide different ways of seeing and solving the problem.

The Need for Explicit Language

Architects typically learn to design without acquiring a language that can describe their design actions. While a designer may have a good tacit justification for his or her design work, finding the words to express the justification may be very difficult. As a result designers are often considered artists, guided by a muse and incapable of explaining their design work.

Change, however, is creeping into the profession. 'Corporate architecture' has become the norm for many of today's practicing architects, with clients becoming increasingly educated and sophisticated in their approaches to architectural projects. The result has often been the elimination of the designer as the key decision maker on a project. When making decisions about a project, clients and their representatives expect the architect to use explicit and understandable language. While yesterday's designers might have been able to justify the addition of a \$50,000 design feature with a reason such as, 'My intuition tells me it will be better,' today's designers can no longer succeed with such justifications. Instead the designer must be able to explicitly tell the client how the added design feature will benefit the project, thereby justifying its additional expense.

The need for an explicit language which is capable of describing the design process could not be greater. Removing designers from the decision making process risks significant degradation in overall design quality.

Computational Models

The advent of affordable hardware and efficient software has brought computer technology into the architect's office. Aid from current computer applications, however, is primarily limited to the production of technical drawings. The creation of a computer environment that can aid in the design process may be of great benefit to the architectural profession. To create this environment, however, a more specific understanding of processes used by architectural designers along with a language to express these processes must be developed. For a computer to succeed as a design tool, it must be congenial to an architect's thinking and working procedures. The future ideal computer might also be one that learns from its own experiences. Understanding structures of design knowledge and design methodology will help in the development of such a computer environment.

• Structure of Thesis

This thesis presents, and explores, one approach to understanding design methodology. The first section, 'A Design Methodology,' explores methodology as it is currently understood by various researchers and architects. The second section, 'The Cases,' contains an extensive exploration and testing of some of the concepts proposed in the first section. The final section is the Conclusion which explores numerous implications of the approach used for studying design methodology in this thesis. These implications relate to the current

study, possible future studies, and my own process and awareness as a designer. An Appendix follows which contains the complete transcriptions of the design exercises created and executed for this thesis. A Bibliography concludes the thesis.

A Design Methodology

• Design Worlds

All designers, be they lay, novice, or expert approach design tasks from 'design worlds' that function as holding environments for their design knowledge. Whether the task be adding a shelf to a laundry room wall or the design of a multi-million dollar building, the contents of each designer's design world will influence the manner in which problems are framed, engaged, and solved. The contents of the design world will also influence how the designer learns from his or her experiences. Features of these design worlds may be broken into at least two major categories: substantive knowledge and process skills.

'Substantive knowledge' refers to what a designer 'knows' while 'process skills' refers to what a designer 'does.' These two categories are necessarily intertwined. If a designer has extensive design knowledge, but no way to implement, modify, and express it, then his or her designs may never grow to fit each problem's unique situation. The designer may also discover that he or she lacks the ability to put his or her design work into a form where it can be viewed by others. Similarly if a designer understands how to express and modify designs, but has little design knowledge, then his or her work may lack variety and depth.

These two categories intertwine to create a process of intelligent reflection whereby a designer observes a situation, reflects upon it, and makes discoveries about it. These discoveries expand his or her knowledge and become the seed for further designing.

• Substantive Knowledge

Introduction

A designer's substantive knowledge originates in his or her unique history, from the passing present to the distant past. The way in which this history is understood as well as the parts of it that are utilized by the designer will provide him or her with certain skills, abilities, and predilections. It will also serve as the store-house for the designer's design memory. As a designer's substantive knowledge grows, he or she will be able to perform more comprehensively and efficiently. Substantive knowledge is content rather than process based. It is important to understand, however, that although substantive knowledge does not involve process, it holds a great deal of knowledge about process.

Among the many things that are a part of a designer's substantive knowledge is his or her recognition, understanding, and use of 'types' and 'rules.'

Men and women have used types and rules in their designing throughout history. In ancient times architectural knowledge was relatively stable and was based on a set of known and unchanging principles. As Aristotle engaged in philosophical thinking, ancient master builders believed in a single, ultimate truth. Orientations of buildings were not subject to complex user and environmental issues; they were subject to the rules of the gods. Similarly, the locations of entrances were dictated by numerous rules that told where a particular god liked his or her entrance situated. Even when 'consultation' with the gods was not required, rules existed which were used for determining configurations of particular building elements. In the first century B.C.

Vitruvius provided an extensive codification of rules in his *The Ten Books on Architecture*. In 1573 Philip II proclaimed the Laws of the Indies. These laws set forth uniform standards and procedures for the planning of towns and their surrounding lands in the new world. Among the rules was:

The whole plaza and the four main streets diverging from it shall have arcades...

In the early 20th century the Beaux Arts tradition of architecture utilized a set of rules for designing buildings. These rules dealt not only with individual elements of buildings, but also with the relationships of the elements. The modernists who followed World War Two attempted to abandon reference to all historical types by starting with an original approach for each design. While this methodology may have been successful during modernism's formative stages, the modernist tradition soon created its own types which, not unlike those of earlier periods, dealt with both the 'proper' way to design individual elements as well as the relationships of the elements.

More recently, the use of types and rules has changed. Priorities among rules have become vague; each problem is unique with its own particulars that cannot be readily applied to a wide variety of other problems. Thus the designer must attempt to clarify the problem's situation so that he or she might be intelligently guided. John Dewey, who wrote extensively about learning and education, suggests that this clarification is not accomplished merely by the accumulation of 'brute facts:' it requires clear and concise thinking. He says:

Thinking which is a method of reconstructing experience treats observation of facts...as the indispensable step of defining the

problem, of locating the trouble, of forcing home a definite, instead of a merely vague emotional, sense of what the difficulty is and where it lies. (Dewey, 1948)

Although there are still traditions of architecture that advocate a design process amounting to little more than the selection of elements from catalogues which can then be combined according to the tradition's rules of practice, there are many more schools of thought that fall into line with Dewey's beliefs. Architectural design, in fact, may be regarded as an exemplar of his philosophy.

Types - Background

Given that designers' uses and understandings of types have been important to the design process throughout history and into the current time, it is appropriate to reflect on recent thinking with regard to the concept. How is design knowledge carried by, and applied from, types? How might different types be categorized? Few words have such ambiguous and varied meaning between different researchers and designers as do 'type' and 'typology.' In this background section a number of these views are discussed. It should be understood, however, that these views are generally complimentary. Each writer views the notion of type through a particular lens that focuses on certain features of the concept. A more complete understanding of the concept of type can be obtained by considering the different views holistically instead of as isolated elements.

John Habraken proposes that types are the shared images of social bodies. A body of people know what a type is because it is embedded in their culture. He says:

The concept of type...is much more than a means for classification and more than a way to indicate the historic origins of a form. It is a complex form that lives within a social body: a knowledge, familiar to a group of people by common experience. Types come and go within societies and their cultures. They are, to a large extent, those cultures. (Habraken, 1985)

Because these implicit types are so much a part of a culture, they need not be put into an explicit form. Habraken also believes that types are so rich and full of meaning, that no matter how hard one might try, he or she will never be able to list all of the constituent elements of any given type. Similarly, if two people each decide to make independent lists of what makes up a given type, their lists will never completely agree. This is not to say that one list will be incorrect. Rather it is meant to illustrate that all descriptions of a type can be valid without exhausting the type's possibilities. Habraken argues that typically it is only when a type is challenged that its existence becomes evident. Intrusions by people outside of the culture or changes during times of rapid expansion are examples of when a type may be challenged. In these instances it may become necessary to put as much of the type's contents as possible into a written form.

Habraken does not limit the use of type to traditional cultures or informal processes in primitive cultures. He says:

Behind all this formalization large numbers of consultants, researchers, designers, and engineers operate in concert and we suspect that, to make anything work at all, there must likewise be some shared image of the whole already familiar to all involved. (Habraken, 1985)

He believes that types also allow people with different interests in the same object or process to work together. Knowledge of the type being used allows a diverse group of people working together on a particular project to communicate with each other. Under this model the use of types is of particular importance in architecture.

Rafael Moneo traces the historical development and use of the concept of type, referring to type as:

...a concept which describes a group of objects characterized by the same formal structure. It is neither a spatial diagram nor the average of a serial list. It is fundamentally based on the possibility of grouping objects by certain inherent structural similarities. (Moneo 1978)

He also notes that architectural objects must at once be considered as unique entities and as belonging to a group of repeated and repeatable objects. Knowledge of type therefore allows architects and researchers to speak about a piece of architecture in terms of both its singleness and its features which are shared by other pieces of architecture.

Numerous writers have examined the manner in which the notion of type is used in the architectural design process. Peter Rowe, for example, includes typologies among his five classes of heuristics used in the design process. (The other heuristics being Anthropometric Analogies, Literal Analogies, Environmental Relations, and Formal Languages.) He discusses type as being a heuristic that allows a designer to apply knowledge about past solutions to current related architectural problems. He quotes Quatremère de Quincy saying:

The word type presents less the image of a thing to copy or imitate completely than the idea of an element which ought itself to serve as a rule for the model. (Rowe, 1987)

In Rowe's discussions he divides types into three sub-classes. (Rowe, 1987)

1. Building Types as Models. Type, in this case, refers to a model that has characteristics worthy of emulation. For example, a designer knows what is included in the design of a courtyard house.
2. Organizational Typologies. These are references that help a designer with spatial distribution and conformation of functional elements. For example, a designer could refer to a classical villa facade for organizational information.
3. Elemental Types. These are prototypes for solving general classes of design problems, such as entrance locations for a building.

Donald Schön and William Porter extend the notion of type beyond its traditional usage and meaning. They discuss type as:

...particulars that function in a general way or as general categories that have the fullness of particulars. (Schön, 1988)

While the notion of 'particulars functioning in a general way' is common to numerous theories of type, the notion of 'general categories that have the fullness of particulars' is more unique. Allowing the notion of general categories to enter into the theory, however, allows a richer and more comprehensive description of the role of type in the design process. Schön and Porter propose four categories of types: (Schön, 1988)

1. Spatial Gestalts.
2. Functional Types.

3. References.

4. Experiential Archetypes.

Elsewhere referring to types, Porter says:

Types might be thought of as experienced in examples, remembered through them, with the world of qualities and attributes always possible to reconstruct and formulate as one probes the mental constructs that is the exemplar itself.

One re-experiences some how the artifact, at the time, sometimes drawing from it information that was not accessible before, but becomes accessible because of the particular design situation one finds oneself in. (Porter, 1988)

Porter's observations are similar to those of Gabriela Goldschmidt who notes that the problem solving process is one whereby the designer manipulates a part of the problem in an effort to transform it into something with which he or she is already familiar. (Goldschmidt, draft) When a designer says that he or she is trying to 'understand' the problem, it is likely that what is really meant is that he or she is attempting to match the current situation to a known, similar situation. When a part of the problem solution matches a known type, a tremendous amount of information can be derived from the known type and applied to the current problem.

Schön and Porter also argue that specific rules about designing are derived from types.

As rules of law are derived from judicial precedents...so design rules are derived from types, and may be subjected to test and criticism by reference to them. (Schön, 1988)

It would be possible to derive other categories in discussing the notion of type and typology. It would also be possible to study the similarities and differences of the various theories of type proposed by different researchers. Frequently what appears to be a difference between two researchers turns out to be a similarity that has been obscured by language. Furthermore, when differences in theories do exist they are often complimentary. While one style of lens allows a particular aspect of design behavior to be seen and described, a different style of lens allows a different aspect of design behavior to be seen and described.

This thesis appropriates the theories of numerous writers and researchers to create a framework which can be partially explored in greater detail. This framework includes:

1. Spatial Gestalts.
2. Functional Types.
3. References.
4. Experiential Archetypes.
5. Design Icons.
6. Design Canons.

The first four categories, appropriated from the research of Schön and Porter, are capable of describing many of the manifestations and uses of types. The last two categories, appropriated from the work of Rowe and Broadbent, describe occurrences of type not covered by Schön's and Porter's model. While it might be possible to further divide or extend these categories, it is this list that will be described, developed, and tested. It will also be informed by the research and theories of Habraken, Moneo, and others.

Types - Spatial Gestalts

The term 'Spatial Gestalt' is taken from gestalt psychology. Although theories in gestalt psychology have applicability to many areas, they are particularly useful in examining elements of visual perception. Gestaltists argue that in visual perception, elements are grouped into cohesive forms or shapes that have particular patterns or configurations. These patterns take precedence over, and have qualities that are not inherent in, the individual elements. Thus a designer may look at a particular floor plan and instead of reading it as a number of different unrelated elements, read it as an 'L' or 'W' shape.

In the design process the gestalt figure is typically perceived rather quickly by the designer. The gestalt will therefore have a strong influence on the manner in which the designer understands and interacts with the problem. For example, a designer's perception of a 'W' shaped spatial gestalt will drive his or her design process as he or she sees and reasons upon the figure.

Gestalts are ultimately created by the individual designer. For example, in looking at a building's footprint it is possible that no two designers will perceive the same gestalt. On the other hand, it is also possible that numerous designers will perceive the same gestalt. In these instances, however, it is important to understand that while numerous designers may make reference to the same type, in many cases their understandings of this 'same' type's contents and significance may radically vary.

Research done in gestalt psychology indicates that there are several principles that influence the perception of gestalts. One of these principles, 'closure,' states that people have a tendency to fill in small pieces that are

missing from a figure. For example, if an ellipse shape with several small gaps is shown to a person, unless the gaps grow too great, the person will still perceive the shape as an ellipse. The second principle, 'continuation,' states that people have a tendency to see gestalts in smooth, continuous forms rather than in irregular and abruptly changing forms.

Of course this all assumes that designers will perceive a gestalt figure whenever possible. Studies in gestalt psychology have shown that the ability to perceive gestalts depends on physical characteristics of the stimulus as well as previous experiences to similar stimuli by the observer. There are also indications that an individual's relative desire to order and organize his or her surroundings may influence his or her ability to perceive gestalts. Although all people are to at least some extent concerned with organization, for many people it is an overriding factor in their daily lives. For them the perception and use of gestalts may be natural. For people who do not feel the need for such order, however, the perception of gestalts may be less natural. Thus a person's particular background and world influences his or her tendency to perceive spatial gestalts.

Gestalts may be perceived in many elements of a building's design. For example, in site planning the designer may perceive a gestalt figure in the component parts of the site plan: property lines, parking areas, building footprint, landscaping, and roadways. During design of exterior elevations, gestalts may be perceived from patterns of windows, doors, finish materials, and facade shapes. Floor plans also lend themselves to the perception of gestalts during the design process, both in their perimeter and interior configuration.

Types - Functional Types

Schön refers to functional types as consisting of:

...types of buildings or physical environments, or parts of buildings or environments. (Schön, 1988)

Functional types are typically used for the richness they contain about a type, supplying intermediate premises in chains of design reasoning. For example, designers have a knowledge and understanding about what an inner-city site means in terms of design: it may be subject to crime, be in a densely built-up area, and have little or no available parking.

Some designers will have more functional types in their design worlds than will other designers. The style and content of a particular functional type will also vary between designers. To a certain extent these types are culturally and regionally based. Even within the continental United States differences in understandings of particular functional types can be seen. A designer from a northwestern part of the country may have a much different repertoire of functional types than a designer from a northeastern part of the country. Similarly, the contents of the same functional type may vary depending on the culture and region of a designer. It is not difficult to imagine how a designer from a sparsely populated area in the desert southwest might have an understanding of 'suburban branch library' that is significantly different from that of a designer from a densely populated area of the northeast.

Within the architectural profession it is common for many clients to only consider hiring an architect who is from the region in which a proposed project will be located. These clients may understand that it is probable an architect from the project's region will have an increased sympathy for, and

knowledge about, the functional types which deal with the unique problems and opportunities of the project's site and region.

Types - References

References may be to particular buildings or particular kinds of buildings. They are used as specific guides for design reasoning. A designer may, for example, refer to a building, or an element of a building, as being 'Richardsonian:' referring to the architecture of H. H. Richardson. References may be used as either positive or negative examples against which a designer can check a proposed design move. A designer may decide to emulate a reference because of its perceived quality or avoid the reference because of its perceived lack of quality.

Types - Experiential Archetypes

Experiential archetypes are images of experiences, objects, settings, or things that are personal to a culture or a designer. Schön and Porter note that experiential archetypes function as 'generative images' for major premises in chains of design reasoning and that they frequently become evident when a designer is in the 'felt-path' mode, imagining what it would be like to be in or around a particular space.

Experiential archetypes are almost 'mystical' in character. They speak of spirit, and not necessarily of form, though a reference to form may accompany them. They relate strongly to the emotional power of the particular reference. For example, a designer might refer to a particular building element as being like a 'cave.' This reference, however, would not be to the element's physical resemblance to a cave, though it may also be physically reminiscent of a cave,

but to the element's spirit or emotional qualities which are similar to those of a cave.

Types - Design Icons and Design Canons

The terms 'Design Icon' and 'Design Canon' are derived from Geoffrey Broadbent's notions of 'Iconic Analogy' and 'Canonic Analogy.' Rowe has borrowed the terms from Broadbent and groups them into a category that he describes as 'Literal Analogies.' He defines literal analogy as:

...borrowing known or found form giving constructs as a point of departure for structuring a design problem.

Thus when a designer makes use of a literal analogy, he or she focuses on certain elements of the analogy and translates them literally into the built form. (Broadbent, 1973) Under this model the analogy can be to both architectural and non-architectural references.

In appropriating these notions for this thesis, however, I have elected to restrict their use to non-architectural references. I have also decided to name the concepts 'Design Icons' and 'Design Canons' to avoid problematic issues inherent with the term 'analogy.'

'Design Icons' can be taken from any part of the surrounding world and applied to the design process. The icon selected serves as a metaphor which guides the designer. A design icon was used by Le Corbusier in the design of the chapel at Ronchamp when he used a shell as his inspiration for the form of the building's roof. He said:

The shell of a crab picked up on Long Island near New York in 1946 is lying on my drawing board. It will become the roof of the

chapel: two membranes of concrete six centimeters thick... The shell will lie on wall made of salvaged stones...(Le Corbusier, 1957)

A design icon was also used by Frank Lloyd Wright who claimed that his inspiration for the form of the Unity Church was the figure of two praying hands. He wanted a form that could point to the heavens and symbolize aspiration without resorting to the traditional use of a steeple. Another example of Wright's use of design icons is seen in his design of the Johnson Administration Building where he used water lilies for his inspiration of how the concrete columns would come together and form the ceiling of the central work space. Like water lilies reaching to the top of a pond he designed these columns to spread at their tops as they met and held the roof. In between the column's capitals Wright placed glass to reinforce the underwater effect. (Broadbent, 1973)

'Design Canon' refers to a set of rules, or guidelines that can be used as references for proportions or formal geometries. It is important not to confuse the function of these geometries with those of spatial gestalts. Unlike spatial gestalts, these figures are typically invoked explicitly rather than implicitly. Also, they are typically used primarily as a heuristic, providing guidelines for the manner in which design elements may be located. Of course as elements are placed and these geometries are filled, it is likely that a gestalt figure will be perceived by the designer.

A traditional and typical example of a design canon is the structural grid for a building. There are, however, examples that are more unique and complex. One such example is illustrated through the work of Walter Netsch. Netsch's entire design methodology is driven by what he refers to as 'field theory.' With

field theory the first step in designing involves the creation of a complex grid pattern upon which the building can be designed. This grid drives the entire design process. With reference to this methodology Netsch says:

Technological architecture, which is different from Mies, was leading to some aggressively ugly buildings...We do not start with the material as the demigod, but with the ordering as the demigod. (Progressive Architecture, April 1973)

Netsch's canon is used in the design of all the building's elements including floor plans, elevations, and interiors.

Judgments

A designer's ability and willingness to make normative judgments of quality is essential to the progress of the design process. Many designers, particularly novices, are reluctant to make such judgments for fear of being wrong. It should be understood, however, that no designer's qualitative judgement can be wrong. When a designer makes such a judgment it is an assertion of something that he or she believes to be true: an opinion or estimation. Thus qualitative judgments are completely subjective.

A group of professionals might decide that one judgment is better than another. Further they may decide that certain judgments are 'good' or 'reasonable' and that a designer who believes as they is a 'wise' designer. They may, in fact, become so convinced of the correctness of their judgments that they present their judgments as facts. These 'facts,' however, may completely contradict the 'facts' of a different group of professionals.

Qualitative judgments help to form what is perceived as a designer's personal style and combine to create, at least temporarily and from each

designer's particular point of view, an objective world. If no qualitative judgment can be factually right or wrong, however, how does a designer decide that a judgment will be, at least temporarily, right or wrong? How do designers create objective decision processes based on subjective knowledge? Geoffrey Vickers and Christopher Alexander each provide some indication of how this world making occurs.

Vickers notes how judgments indicate what he refers to as a set of 'readinesses' to distinguish, classify, and value some aspects and not others of a particular situation. Of readinesses he says:

These readinesses have to be learned; and like all learning, they are necessarily limiting, as well as enabling. They facilitate further learning consistent with the patterns which they create; but they create 'un-readinesses' to see, to value and to respond in ways inconsistent with those patterns...

...Limiting though they must be, such readinesses are precious; for without them we could not see or value or respond to anything in any way. (Vickers, 1965)

'Readinesses' are the predilections of the designer and are based on his or her experiences. Elsewhere Vickers describes readinesses as comprising an 'appreciative system.' Of the appreciative system he says:

I regard an appreciative system as a work of art, both personal and social, one that is constantly revised or confirmed by the three needs. First, it should correspond with reality sufficiently to guide action. Second, it should be sufficiently shared by our fellows to mediate communication. Third, it should be sufficiently acceptable to ourselves to make life bearable. It is thus a mental construct, partly subjective, largely intersubjective, that is, based

on a shared subjective judgment, and constantly challenged or confirmed by experience. (Vickers, 1983)

The appreciative system, which contains all of the designer's readiesses, allows him or her to see a situation and decide whether or not it should be approved. It is noteworthy that although the designer may consider 'approved' as meaning 'correct,' the correctness of his or her decision is largely personal: it may or may not be considered correct by others. It is this process, however, that allows the designer to progress with his or her designing. Even when designers deal with 'reality' instead of 'value' judgments, issues of value are still unavoidable. The facts that will fill a designer's 'reality,' for example, are selected based on what the designer considers as relevant and what he or she 'values' as interesting and significant to the particular situation. A designer with different values might select a different set of facts to fill his or her reality.

Alexander believes that a good design is one where a 'fit,' typified by a relation of 'mutual acceptability' between form and context, occurs. He notes, however, that it is impossible to give a thorough description of a problem's context. Thus the process of problem solution becomes one of exploration. In this process the designer tests entire or partial solutions to see if they will fit. The question arises, however, as to how the designer knows when a move is a 'fit' or is affirmed. Alexander notes that it is easier for designers to recognize a problem's 'misfits' than its 'fits.' It might be asked why misfits stand out and are more compelling to designers than fits. Alexander says:

When we speak of bad fit we refer to a single identifiable property of an ensemble, which is immediate in experience, and describable. Wherever an instance of misfit occurs in an

ensemble, we are able to point specifically at what fails and to describe it.....

...I should like to recommend that we should always expect to see the process of achieving good fit between two entities as a negative process of neutralizing the incongruities, or irritants, of forces, which cause misfit. (Alexander, 1964)

Appreciative systems are a part of a designer's substantive knowledge and are developed throughout his or her career. Thus a designer's appreciative system is formed by what is seen at the same time it allows and encourages certain things to be seen and considered salient.

• Process Skills

Introduction

Process skills allow the designer to engage in the design process and manipulate the materials of the design problem, becoming intimate with, or a part of, the process. These skills allow designers to apply their substantive knowledge to the design task. They also allow new information from the task to be incorporated into the designer's substantive knowledge where it can be used both immediately and in future design problems. Although there is a great deal of knowledge involved in the application of process skills, they carry no design knowledge of their own.

The process of designing involves a 'conversation' between a designer and the problem under consideration whereby a process of 'seeing-moving-seeing' is employed. This process of 'seeing-moving-seeing' represents a small experiment conducted by the designer in an effort to solve or better understand all or part of the problem.

Within each small experiment the chance for 'discovery' always exists. New information that is discovered in the process of experimentation will become the seed for new and continuing experiments. In design this means that after a discovery is made, the conversation between the designer and the problem is continued with a new series of sketches, each of which is informed by previous discoveries. In Dewey's words:

Concrete suggestions arising from past experiences, developed and matured in the light of needs and deficiencies of the present, employed as aims and methods of specific reconstruction, and tested by success or failure in accomplishing this task of readjustment, suffice. (Dewey, 1948)

It should be understood that the process of seeing-moving-seeing is much different from that of trial and error; instead of making random guesses about possible solutions the designer is guided by intelligent reflection.

Designing as a Conversational Process

Design problems are inherently ill-defined and full of confusing and conflicting information that must eventually be resolved during the design process. At the beginning of the process it is virtually impossible to know everything that a completed solution will include. Thus the design process entails a gradual unfolding and evolution of information which informs, and is informed by, the designer's work. The process that allows this gradual unfolding of the problem to occur can be referred to as a design 'conversation' and can be characterized by a process of 'seeing-moving-seeing.' (Schön / Wiggins, forthcoming)

One of the first steps a designer will take as the design process begins is to see and understand the content of a given problem.

The first distinguishing characteristic of thinking then is facing the facts - inquiry, minute and extensive scrutinizing, observation. (Dewey, 1948)

This understanding is facilitated by the designer as he or she translates elements of written and verbal data into a sketch where they can be seen and understood in a graphic format. This reliance on graphic representations is one part of the architect's design process that separates it from many of the other creative fields. In fact, sketching encourages much of the creative work in architecture.

It is important to note that frequently the sketches a designer produces will be of a crude and ambiguous nature. This is not only because the information the designer begins with is crude and ambiguous, but also because sketches of this sort allow many options and opportunities for how they can be read and understood. In fact the crude quality of a sketch often provides the designer with fuel to power his or her design process.

Also, as discussed below, all moves have unintended consequences which accompany their intended consequences. It is difficult for a designer to work through all of the consequences that a move might have on the entire problem 'in his or her head.' Sketching allows the proposed move to be put into a concrete form where its consequences can be considered across the entire design problem.

Sketching also facilitates design conversations. With the first sketch produced the designer is free to completely engage the problem. The first step,

of course, is for the designer to see what he or she has drawn. In the conversational sense it can be said that the problem is 'speaking' to the designer through the sketch. Based on what he or she sees, the designer, by either adding to the existing or producing a new sketch, makes a design move which it meant to test or evolve some part of the problem. In the conversational sense it can be said that the designer 'speaks' to the problem through the sketch. This sketch provides feedback in the form of new information which the designer sees as he or she once again 'listens' to the problem.

Thus the term design 'conversation' can be understood as a process of 'seeing-moving-seeing.' This process of 'seeing-moving-seeing' represents a small experiment conducted by the designer in an effort to solve or better understand all or part of the problem. The entire process becomes one of growth.

...designing (can be seen) as a cumulative process of discovery whose output is not only an elaborated intention but an enriched understanding of relationships among moves, consequences and qualities across multiple domains. (Schön/Wiggins, forthcoming)

A design 'move' should be understood as involving more than just the sketching process. The first real design movement involves reflection. As a designer considers a problem he or she will develop an idea for a move which might solve all or part of the problem. Sketching is therefore the manifestation of a reflective move.

'Seeing' should be understood as having two different but complimentary meanings. First, the designer literally 'sees' information on a drawing. This sight includes not only the registration of data, but also the perception of

figures in some of that data. 'Spatial Gestalts,' which are discussed in the Substantive Knowledge section of this thesis, are perceived rather quickly by the designer. Second, the designer 'sees,' or understands the implications of some aspect of what he or she has literally seen. This type of seeing requires a designer to make judgments about some part of the design.

The Discovery Process

The above description of seeing-moving-seeing shows the design process to be one of gradual transformation whereby the final design is the cumulative effect of many design moves which have been informed by judgments. This process can also be described as one of 'discovery.'

Although the act of discovery is by its nature but a moment in the overall design process, it is useful to think of it as having three phases:

1. The moments leading to the discovery
2. The moment of the discovery
3. The reaction to the discovery

The moments leading to the discovery are those where the designer literally sees and reflects on what he or she has drawn. This reflection leads to the moment of the discovery where the designer sees, or understands the implications of what he or she has drawn. The reaction to the discovery can take one of two forms: understandings can either be 'swept aside' or used to inform subsequent moves. Understandings which are swept aside are not incorporated into the current design process. Understandings that are used to inform subsequent moves, however, can either be incorporated into the process immediately or in the future. A discovery that is not of immediate importance may be of great importance as the problem unfolds. In either

event the discovery becomes the seed for new moves in a continuing conversation, thereby giving a cumulative effect to the designing.

Whether discoveries are swept aside or used to inform subsequent moves, they typically provide the designer with a deeper understanding of the problem. In some cases a discovery will be of such a radical nature that it will lead the designer to redirect his or her designing and begin a new experiment. These instances, however, occur rather infrequently. It is much more common for the designer to experience many small, but significant, moments of discovery throughout the entire design process, with each moment informing the next in a process of seeing-moving-seeing.

This is not to imply that every experiment will lead to a discovery. Many experiments will lead to dead-ends. Even in these instances, however, new knowledge is gained as the designer sees that a proposed move will not solve the problem. Neither is there a guarantee that the designer will notice a potential discovery. Again, the ability to see depends to a certain extent on the level of development which the designer's appreciative system has reached.

Unintended Consequences of Moves

When a designer conducts a move experiment, it is typically with the goal of resolving a specific part of a design problem. Part of the complexity and richness of the design process, however, stems from the fact that the designer's move experiments have consequences reaching far beyond his or her original intentions. This rippling effect can make even the smallest design move a 'giant step.' How a designer deals with the unintended consequences of his or her moves says a great deal about his or her design methodology.

In conducting a move experiment a designer will typically make a move and then reflect on it to see if its intended consequence has been affirmed. At the same time, however, the designer also sees and reflects on the unintended consequences of the move. These unintended consequences must be judged along with the intended consequence. Unintended consequences are often surprise discoveries for the designer. Some of these surprise discoveries may be of a positive nature, supporting the intended consequence of the move, while others may be of a negative nature. Even if the intended consequence of a move is judged as positive, the negative nature of unintended consequences may cause the overall move to be denied instead of affirmed. Similarly if a move's intended consequence is affirmed, any negative unintended consequences that accompany it may cause the designer to refocus his or her area of inquiry to resolve the unforeseen problem.

Frequently the elements of a move's intended consequence are radically different from the elements of its unintended consequences. Schön proposes that elements of designing can be grouped into 'domains.' He says:

Elements of the language of designing can be grouped into clusters, of which I have identified twelve. These design domains contain the names of elements, features, relations, and actions and of norms used to evaluate problems, consequences, and implications. (Schön, 1987)

Examples of domains include 'Form,' 'Scale,' and 'Organization of Space.' A designer consciously works in one domain at a time, attempting to solve problems or realize opportunities. As discussed earlier, when a designer makes a move to solve a problem, he or she reflects on the move to see if its intended consequence has been affirmed. This intended consequence will be in one

domain. Unintended consequences, however, frequently occur in other domains. Thus, for example, as a designer makes a move in an attempt to resolve a problem of scale, the move may also effect the way in which space is organized.

Earlier Alexander's notions of 'fit' and 'misfit' were discussed. Alexander believes that if a designer attempts to list all of the fits and misfits of a design problem, the list will be impossibly long. To handle 'highly amorphous and diffuse' problems he proposes a notion similar to that of domains. He says:

Since we cannot refer to the list in full each time we think about the problem, we invent a shorthand notation. We classify the items, and then think about the names of the classes: since there are fewer of these, we can think about them much more easily. To put it in the language of psychology, there are limits on the number of distinct concepts which we can manipulate cognitively at any one time, and we are therefore forced, if we wish to get a view of the whole problem, to re-encode these items...Each of these concepts is a general name for a number of the specific requirements. (Alexander 1966)

By grouping design information of like kinds into domains, the designer can more easily deal with the complexity of design problems. Even a limited number of domains, however, may be difficult for the designer to effectively manage.

It is possible that due to a limited ability to cope with a problem's complexity, as well as a limited awareness of a move's potential scope of influence, many designers may typically be able to consciously work in only one domain at a time. Expert designers may, on some occasions, be able to work simultaneously in multiple domains. It is possible, however, that these

experienced designers are simply using 'chunks' of information with which they are already familiar. In these instances the designer might see a problem as being similar to one that he or she has previously experienced. Rather than working through the problem again, the designer will be able to apply the known 'chunk' of information to the task. If the chunk contains materials from multiple domains, the designer will appear to be simultaneously working in multiple domains.

It is also possible that expert designers are able to rapidly switch between different domains, thereby providing the illusion of simultaneity. It is as if the domains are represented by nodes, each interconnected by conduits that allow the designer to move between them. The expert will be very familiar with the nodes and their connections and will therefore rapidly move between them. In contrast the novice will lack familiarity with the nodes and their connections. He or she will therefore move between them very slowly, if at all.

• Lay, Novice, and Expert Designers

Background

In her book *Conceptual Changes in Childhood* Susan Carey describes the work of Chi, Glaser, and Rees which claims that non-conceptual differences between novices and experts in scientific domains can be characterized by three principle methods:

1. diagnoses of misconceptions.
2. analysis of perceived similarities among elements in the domain.
3. information-processing analyses of how problems are solved.

For each of these methods she then provides examples that illustrate the notions. For the first method she describes a situation whereby it becomes

apparent that novices can have misconceptions that are highly resistant to tuition.

For the second method she provides an example illustrating how people with differing knowledge levels of physics perceive physics problems. A group of novices and experts are given a number of physics problems and are asked to group them according to their similarities. Novice participants group problems according to the type of objects involved: problems about pulleys in one group, problems about inclined planes in another. Expert participants, on the other hand, group the problems according to their method of solution: problems solvable with Newton's laws of motion in one group, problems solvable by energy equations in another. Thus this study shows that novices and experts organize their knowledge of physics in significantly different ways, with experts able to think on a more subtle and complex level than the novices.

For the third method Carey describes how novices, when solving mechanics problems use:

...painful means-end analysis working with equations they hope are relevant to the problem while experts apply correct equations in a forward direction... (Carey 1985)

Thus novices employ a process of trial and error while experts gradually transform the problem using 'correct' information.

Other experiments described by Carey cast adults as experts and children of different age groups as novices. One of the observations made is the manner in which novices 'randomly-attribute' features to similarly perceived objects. For example, a child may attribute the presence of a spleen to an inanimate object

based on the object's perceived similarity to a human. On the other hand, children may fail to attribute a spleen to an animal because of the animal's lack of similarity to a human. Adult 'experts' frequently 'over-attribute' features to similarly perceived objects. For example, an adult may decide that a bat shares many characteristics with a bird based on nothing more than his or her knowledge that both fly. In fact bats and birds are radically different from each other.

Past study indicates that a primary difference between novices and experts is their relative levels of knowledge: experts know more than novices. No doubt increased experience may lead to, but not guarantee, a broader range of substantive knowledge and a more facile use of a wider range of process skills. Carey's studies, however, raise questions about other, more subtle and complex differences. For example, do lay designers randomly attribute characteristics based on a naive understanding of architecture? Do novice designers over-attribute characteristics based on similarities to a known model?

The Cases

• Introduction

To test and expand upon some of the information presented in the Background section of this thesis, I will analyze the results of a number of experiments which have been conducted both by myself and by others at MIT. In each experiment a participant is given a task which causes him or her to engage in the design process. All participants are encouraged to work in their normal fashions with one exception: they are asked to 'think out loud,' thereby providing the thinking that accompanies their designing.

Schön and Porter have developed what I will refer to as the 'Branch Library Exercise.' (Schön, 1988) In this exercise participants are given a line drawing (reference figure below) which represents a 'footprint' for a branch library. On the plan are six numbered arrows representing possible entrance locations. The participants are then given the following task:

A library association of the Commonwealth of Massachusetts has this generic footprint that they use for branch libraries throughout the State, typically in suburban locations. All these are one-storey buildings. They hand the footprint to architects, and ask that the various libraries be designed to fit it. They use the six generic entrances marked with numbers 1 to 6. They have had problems with entrances, and so they have come to you, as consultant, to analyze their entrances for them and give a set of guidelines for the architects that will have to design these buildings. They want to know what each entrance implies as to the siting of the building, the massing, the internal organization, and whatever else seems to you to be important. So, these can be

arranged in any way you wish on the site, and there are varying sites with different directions of access, and so on. The dimensions of the footprint are one hundred feet, from K to B, and eighty feet from B to G.

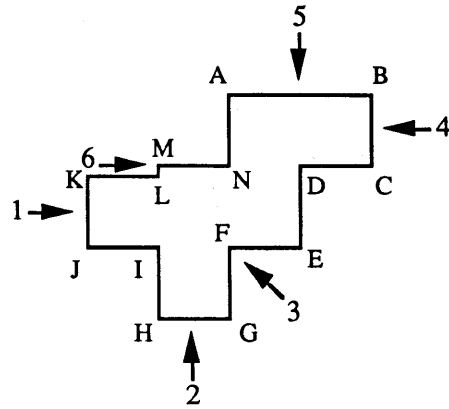

Branch Library Footprint

This exercise was given to seven participants; each in an individual session. Three participants are design instructors at MIT, one is a design instructor from Israel, and three are practicing architects. For this thesis I referenced the protocols of 'Benny,' 'Clara,' 'Gloria,' and 'Gilbert.'

Along with the information available from the Branch Library exercise is information from a series of exercises I developed. These exercises are all loosely based on the original Branch Library exercise and were developed to test or expand on a number of specific design issues. These exercises are grouped together and begin with the following general introduction:

I am going to ask you a number of questions. Some of them may seem silly and some of them may seem more serious than others, but they are all serious. The questions are looking for different things and you need to realize that there are no right and no wrong answers. There are no tricks built into the format; the point here is to study how people think when solving architectural problems. Some of the questions may be answered quickly while others may take a bit longer. There is no rush. If

you look at a question and you do not have an answer, it is acceptable to say so. Similarly, if I present you with alternate answers to a question you may decide that it does not matter which alternative is selected. It is acceptable to say that you do not feel that it matters which option is selected. You may draw if you like; I have tracing paper you can use as well as a variety of pens. This session is very free form. The only thing that I request of you is to think out loud. Rather than internalizing your thought process I want you to verbalize everything that you are thinking as you work through these problems. I will start to pry if I recognize that you are thinking without verbalizing.

What we are going to do is very simple. I am going to show you a number of plan types and ask you a few questions about them.

The individual exercises, which are described below, were given to four participants; each in an individual session. After each session the exercises were slightly modified to correct problems in their format. Each of the participants therefore took a slightly different composition of the exercises. Although the content of the parts did not substantially change, the number and/or the order of parts was revised on each occasion. Five footprint types were used in each exercise. One of these footprints, Footprint Type D, is the same footprint used in the original Branch Library exercise.

Although I anticipated my research ultimately requiring data primarily from 'expert' designers, I wanted novice designers to be represented in my study as well. A review of literature in the cognitive sciences showed me that it is typical to separate participants into two groups: novices and experts. (Carey, 1987) A question arises, however, as to when a designer can actually be referred to as an 'expert.' There are many grades of expertise that occur between true novices and experts. Because of this situation and despite the

traditional categorization, I decided to break my group of participants into three categories: lay, novice, and expert.

I view a 'lay' designer as one who has little or no actual design experience in architecture or one of its allied fields. 'Novice' designers include those who have gained experience in architecture or one of its allied fields, but have little actual professional experience in the architectural profession itself. 'Expert' designers include those who are trained in architecture and have at least three years of professional experience in the field. Note that these categories are created based on level of experience as opposed to perceived quality of design. Under this model it may be possible for a lay designer to be perceived as creating 'good' designs while an expert designer creates merely 'proficient' designs.

My study group includes at least one designer from each of these levels. For the lay designer I selected a fourteen year old boy from a metropolitan area in a southwestern part of the United States. 'Darin' is currently attending high school as a ninth grade student. His interests include sports, music, and academics. He did not express interest in architecture or any of its allied professions.

For the novice designer I selected a thirty-eight year old woman from a metropolitan area in a southwestern part of the United States. 'Linda' is currently employed teaching learning impaired children, though in the past she was trained, and has worked, as an interior designer. She has an undergraduate degree in interior design from a university in Texas.

I selected two participants to represent expert designers. The first is a twenty-seven year old woman from a southeastern part of the United States. 'Lora' is currently employed in an architect's office in New England. She has

over three years of professional experience and has a degree in architecture from a university in Florida. The second, 'Corbin,' is in his late twenties and is from Europe. He is currently enrolled in the SMArchS program at MIT and is a licensed architect with extensive professional experience.

The information provided by this group makes it possible to speculate on some of the similarities and differences of lay, novice, and expert designers. Additional expert information is taken from the results of the original branch library exercise.

• Case One - Gestalts

The Exercise

Participants are given Footprint Type D (reference figure below) and are told that it is the footprint for an inner-city retail electronics store. They are first asked which entrance location they prefer. Then they are asked if they see any geometric patterns in the footprint. If they see geometric patterns they are asked to indicate them on the footprint. They are then asked to describe what the pattern means to them in terms of their designing or organization of the footprint. The process is repeated as participants are questioned about any other perceived geometric patterns.

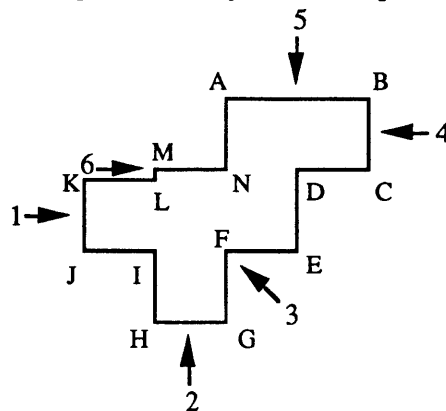

Footprint Type D

The Initial Goal

With this exercise I hoped to get data that would allow an investigation of a number of issues relating to spatial gestalts. For example, if designers recognize and reason upon spatial gestalts, then I would expect them to recognize some type of cohesive geometric pattern in the footprint: an assemblage of parts into a whole that means more than the sum of the smaller parts. Further, I would expect this recognition to occur rather quickly. Explanations of how these patterns inform the designer's understanding of the footprint should help to illustrate how spatial gestalts function in the design process. Finally I hoped to see if different designers would perceive the same gestalt and how their understandings of the significance of this gestalt might be similar or different.

Results

The results of this exercise substantiate the claim that gestalts are perceived and used by designers. The exercise was generally understood by the participants, though on several occasions it was necessary to suggest what one gestalt might be (a 'W') in order to provide a better example of the type of information I was hoping to find.

Corbin was first asked which entrance location he liked best for Footprint Type D. After selecting entrance number five as his favorite he was asked to identify any geometric patterns that he saw in the footprint. When asked the question he quickly said that he saw two 'L' shaped figures (reference figure below).

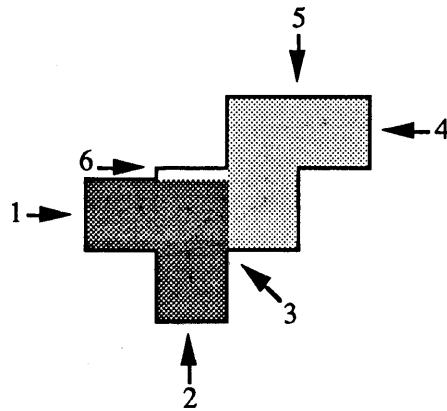

Corbin's Gestalt

When asked how he felt this recognition might have influenced his designing he said:

Well I don't know that it did influence which entry I thought was best...maybe. Its hard to say how it did influence me...maybe it didn't. On the other hand, as I think about it I can see that I thought of the front of the store in terms of this L shape (that entry number five is a part of), and the back, or more exclusive part of the store in terms of this L shape (the other L) - but I don't know.

Corbin answered the question about geometric patterns immediately after it was asked by describing and pointing to the two 'L' shapes. As he answered, there was no pause or delay which might have indicated that he was reflecting on the question. It is therefore likely that he had already perceived the gestalt before the question was asked. His hesitation to answer how the gestalt might have effected his designing, however, would seem to indicate that while he had perceived the gestalt, he had not consciously considered how it effected his design process. His eventual answer, however, indicates that the gestalt he perceived did influence his designing.

Corbin's example substantiates the claim that gestalts are perceived rather quickly by designers. It also substantiates the claim that the perceived gestalt influences the designer's work. In Corbin's case, however, the gestalt influenced his designing at a tacit level. Until questioned he had not consciously associated design reasoning such as 'front and back' of the store with the perceived gestalt.

Linda, in looking at the footprint, quickly perceived what she referred to as a 'W' shape (reference figure below).

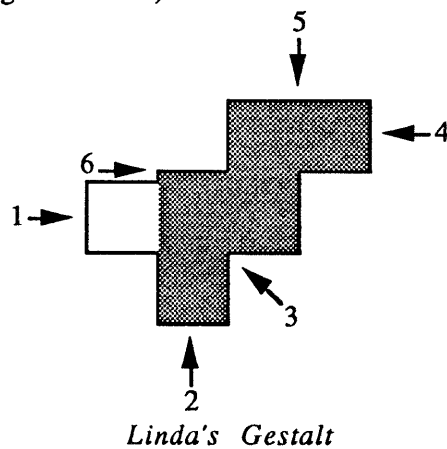

When asked how quickly she had perceived the 'W' she said:

Pretty quick. I see the shapes before I look at the whole thing.

In a follow-up conversation with Linda it became evident that for her 'shapes' referred to gestalts, or in this case a letter of the alphabet. Looking at the 'whole thing,' on the other hand, referred to a detailed review of the footprint. Thus Linda's statement means that before she inspects the entire footprint carefully, she perceives geometric shapes. This substantiates the claim that gestalts are seen as patterns or configurations and that these patterns take precedence over individual elements. It also substantiates the claim that the gestalt figure is perceived rather quickly by the designer.

Lora was asked about geometric patterns for all of the footprints except Footprint Type E. She consistently referred to the footprint as being made up of a central piece surrounded by 'plug-on pieces.' When initially asked about possible geometric patterns in Footprint Type D she said:

...do I see a rectangle continuing through in here, and squares plugged on or maybe this a rectangle? Yes, I see geometries...

...The thing that really hits me, especially on some of those other ones (the other Footprint Types) are...because this is almost a perfect square, then that square is more easily identifiable as a square and so this...as a separate entity...so its easier for that to be a plug-on piece. That's why I've had trouble calling that the front of the building because it looks like its a tack-on piece because its a perfect square and it kind of takes on its own identity. So...but at the same time...like these two pieces...this one is (DCB) harder to see as a plug-on piece even though I know that its the same proportion as KJI and IHG because its at the end of this other piece...from either side...unless you look at four...side four as an entrance you still have that plug-on feeling, but from this side it makes a rectangle there, so four is not the same...

Her spatial gestalt consists of a central rectangle with an attached rectangle and two plug-on pieces (reference figure below).

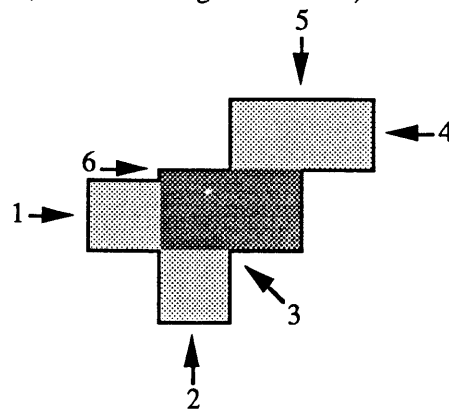

Lora's First Gestalt

Lora's statement, 'That's why I've had trouble calling that the front of the building...' reveals that the gestalt she has perceived has informed her designing. In her world, the front of a building and the building entrance should not be located on a 'plug-on piece.' Any entrance option located on one of the 'plug-on' pieces was therefore eliminated, leading her to ultimately select entrance number five on the 'attached' rectangle. Had she initially perceived a different gestalt that did not recognize the smaller squares as 'plug-on pieces,' her selection of entrances might have been significantly different. Thus Lora's protocol substantiates the claim that the particular gestalt figure perceived by the designer will influence his or her design process.

Later as Lora turned the sheet on which the footprint was drawn and looked at it from a number of different orientations she said:

Also, I also think of this too, especially if you turn it a different way, I think of this KJED as...even though its not a whole shape, I think of that as a core and these two (IHGF and NCBA) being plug-on pieces. (reference figure below)

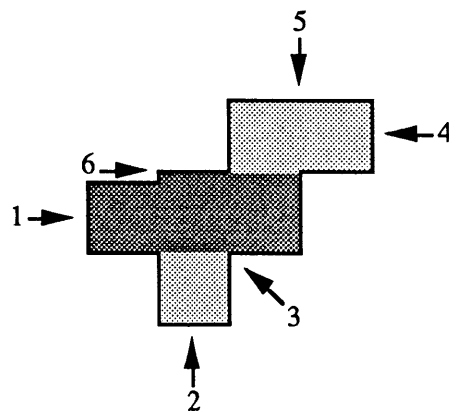

Lora's Second Gestalt

Lora's process of turning the sheet and looking at it from different orientations led her to perceive a new gestalt. This provides reason to suspect that perception of a particular gestalt may be influenced by the orientation of the footprint on the sheet. Rotated ninety degrees the footprint might lend itself to the perception of significantly different gestalts. Lora's case also indicates that, to at least some extent, designers can invoke different spatial gestalts.

While the materials of the footprint may lend themselves to the creation of spatial gestalts, gestalts are ultimately created by the individual designer. In looking at a footprint it is possible that no two designers will perceive the same gestalt. On the other hand, it is also possible that numerous designers will perceive the same gestalt. In these cases, however, it is important to remember that while different designers may make reference to the same type, their understandings and use of the type may radically vary.

For example, when two designers looked at Footprint Type D and both perceived 'back to back' L's in the footprint, the understandings and implications of this perception were different for each designer. As noted earlier, when Corbin was asked how he felt his perception of the 'back to back' L's might have influenced his designing, he described how one 'L' might be viewed as the front of the store while the second 'L' might be the back of the store.

Benny, who participated in the original Branch Library exercise, initially perceived the footprint as consisting of a central space (MDEI) surrounded by 'pods' (reference figure below).

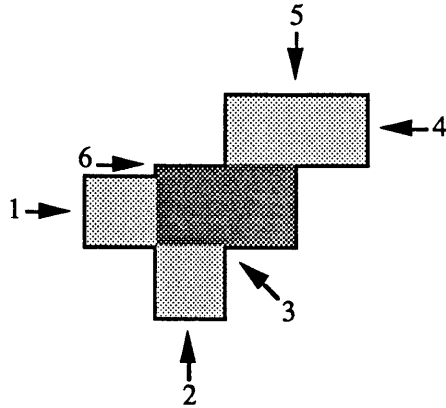

Benny's First Gestalt

As he moved through the design process, however, he said:

What's funny is that I haven't been reading it as two L's back to back, which it also is. And you might read it that way if this were an office building, you probably would.

When questioned about how this new reading of back to back L's might influence his designing, he said:

Well, its hard for me to (do) two full L's because it doesn't leave you any space to move in between the two of them...But it would be almost impossible to find some substantial use that (needed) peace and quiet in the (MDEI) rectangle, because you know that people going from H to B have to cross that. So it would be good in a supermarket, the people having to go through that...rectangle (MDEI), but lousy in almost anything else.

There are several interesting things to observe in this passage. First note that the perception of back to back L's has a completely different significance for Benny than it does for Corbin. At no point does Benny think in terms of front and back of the footprint. Thus it is seen that two designers can use the same type, in this case a spatial gestalt, but arrive at different conclusions about the type's significance.

Also striking in this passage is the manner by which the gestalt which Benny had initially perceived continued to drive his subsequent designing, even as he consciously invoked different gestalt figures. Initially he had been working with a gestalt composed of a central space (MDEI) with a series of 'pods' around it (reference figure above). As stated, however, during the design process he forced himself to examine other possible gestalt figures, considering how they might effect his design. His design reasoning, however, indicates that his initial gestalt was still influencing his designing during this process. For example, while working with back to back L's, he discussed problems with the manner in which the two L's fit together. The trouble area of the fit was in the central rectangular area (MDEI - reference figure below).

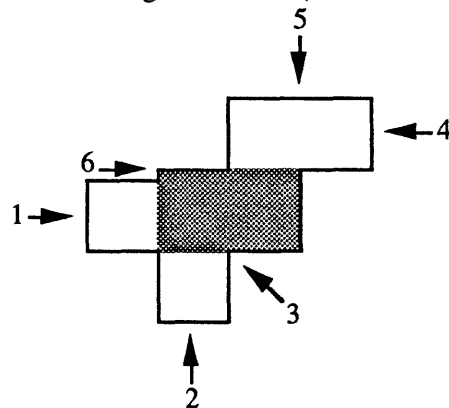

Benny's Trouble Area

He discussed the problem of 'crossing' the rectangle to get from one part of the plan to the other. This rectangle is the same as the central space (MDEI) that he had worked with earlier. Thus, even though he consciously tried to invoke a new gestalt figure, his initial gestalt still drove his design efforts. It is as if he created a gestalt within a gestalt. This illustrates the power that a spatial gestalt can have in the design process. Even when Benny tried to escape the gestalt he had initially perceived, he was still unconsciously influenced by it.

•Case Two - How Universal Are Types

The Jailor's Entrance Exercise

Participants are shown Footprint Type D (reference figure below) and are told that it is for a building of no particular type. They are then asked to say which, if any, of the entrances they consider to be a 'jailor's entrance.' After identifying the entrance the participant is asked to explain why it meets the test of being a jailor's entrance. It is important to make the distinction that the building is of no particular type: it is not necessarily a jail. Thus the participant's selection is based on the concept of 'jailor's entrance' rather than entry relative to some unspecified function of a jail.

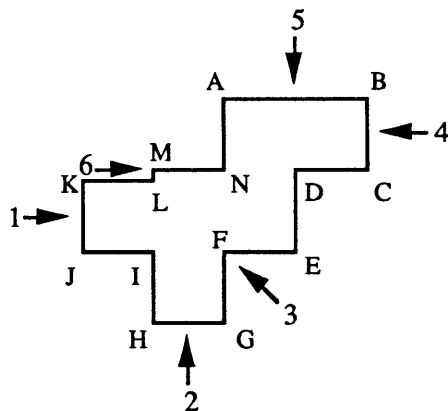

Footprint Type D

The Initial Goal

With this exercise I hoped to discover the universality of a particular type: in this case 'jailor's entrance.' In reviewing protocols from the original branch library exercise, I was struck by Benny's description of an entrance as a 'jailor's entrance.' I wondered if other designers would share his understanding of this type of entrance. I therefore showed my participants Footprint Type D, which was the same footprint that Benny had seen, and asked them to tell me which entrance they considered a 'jailor's entrance.' Would

different designers have similar conceptions of how this type might be understood? Would different designers have varying ideas of what might be characteristic of a jailor's entrance, yet select the same entrance as being appropriate. An observation of this nature would confirm the notion that differing designers can apply different rules from the same type, yet still arrive at the same conclusions about the type's significance. Conversely I might discover different designers providing similar reasoning for their selections, while selecting different entrances. Such an observation would confirm that differing designers can apply the same rules from the same type but arrive at different conclusions about the type's significance.

Results

This exercise was very successful in achieving its goal. All of the participants seemed to understand the question, and all of the answers revealed an understanding of what might be characteristic of a 'jailor's entrance.'

When Darin was asked which of the entrances he considered a jailor's entrance, he selected number six saying:

Six. If this was a jail, well I don't know. If these people are criminals and they're in the jail, you don't worry about them being real comfortable entrances. So I would say six.

When Linda was asked the question she said:

Six...Because its narrow. Its the only little bitty angle like that. There's a solid wall, I assume, that's right on both sides of it. (Legs MN and KL either side of six.) I guess this is solid and so is this. They look like they'd be solid. It looks like it would be narrow and creepy.

Well before being asked which entrance might be considered a jailor's entrance, Lora said:

Number six is out. Unless its a prison.

When she was later asked to explain what made entrance number six appropriate for only a prison she said:

Well because, its the smallest entry. It has this...it seems like a service entrance...it looks like its just about wide enough for a door. We don't have a scale for this, but personally its wide enough for a door. It doesn't have much of an entry statement and why should you have a entry statement to the jail? I mean you shouldn't really celebrate...I mean you don't necessarily have to celebrate the entrance to a jail.

The three participants who engaged in this exercise all selected entrance number six as the jailor's entrance. Their reasons for its selection were very similar: 'not comfortable,' 'narrow,' 'small,' 'a service entrance.' It seems, therefore, that these different designers all shared a number of understandings concerning the characteristics of a 'jailor's entrance.' This is not as much because they all chose the same entrance as it is because of their similar reasoning. These findings illustrate that at least some types have a universality for some designers.

It is interesting to note, however, that Benny, who made the initial jailor's entrance reference in the original branch library exercise, selected both entrances one and two as jailor's entrances. He reasoned that the jailor's entrance provided control and gave a user no idea of what he or she was

coming into on the interior of the building. Further, he selected both entrances three and six as his favorite entrances. He said:

I would always try to put the entrance somewhere in one of those two middle positions (three and six) because the peninsular pieces at the end...seem like good places to use, not for moving (through).

Benny's favorite entrance locations included what the other three participants considered to be the jailor's entrance (number six). Also, entrances one and two, which Benny considered to be the jailor's entrances, were the favorites of the other three participants. Both Darin and Linda selected entrance number two as their favorite, while Lora selected entrance number one as her favorite. Thus Benny and the other three participants were completely reversed in their appreciations of what would be a jailor's entrance and what would be the best 'non-jailor's' entrance for the footprint. While it is not clear whether this reversal stems from disagreements concerning the characteristics of a jailor's entrance, or from disagreements about how to implement similar characteristics of a jailor's entrance, it is clear that Benny's understanding of the type and how it should be implemented varied considerably from the other three participants.

This exercise illustrates two characteristics of types. First it is seen that different designers can understand and share a great deal of information about some types. Within a given culture, to a least some extent, there are universal types. Second it is seen that different designers can have similar labels for a type, but have radically different understandings of the significance of these labels.

The Dream Library Exercise

To further study the applicability and limitations of the concept of type between different designers, another exercise was developed for this thesis. Participants given this exercise were asked to imagine and describe what might be characteristic of a perfect branch library. The emphasis was for them to create a 'dream' as opposed to a 'real' vision. By allowing the participant to dream, he or she was allowed to establish the categories that would be considered significant instead of having categories imposed by the exercise.

The Initial Goal

As with the previous exercise, I hoped to get information that would answer a number of questions concerning the applicability and limitations of the concept of type. Do types have a fullness that is understood between different designers? What kind of information might designers share about types?

Results

This exercise was very successful in achieving its goal. The participants all understood the question and, in some instances, were able to provide extensive answers. The results of the exercise also illustrate differences between the lay and the more experienced designers. The lay designer had a very limited palate of what the dream library might include, while the novice and expert designers provided rich descriptions.

Linda, for example, said that the branch library would have:

A lot of space...a lot of...maybe a lot of glass with a lot of light coming down. Comfortable seating...some secluded areas that you

can read (in). Maybe even a loft...something like that where you could...just the reading rooms...with comfortable seating.

Lora said that the branch library would be:

Very light with windows...lots of natural light.

Some sort of courtyard or acceptable outdoor space to read (in).

Something that was, well, its hard to monitor...I concentrate best in libraries that are not too quiet. I like a lot of stuff going on, but not usually lots of kid stuff going on. So the children's area a little bit more secluded for noise, but circulation is also in there and happening. You know, the circulation is more integrated in with all the rest of the area.

No plastic furniture.

Doesn't need to have pods...not necessarily plastic cubical pods, but to have a row of pods where you can completely go and seclude yourself away from other people, but still have the opportunity to not be that way too. Like the Exeter library...those are pretty nice - those chairs - but, cause they have a window and a desk to work at. The great thing about that library too is that you can see outside the window...not just when you sit down, but they have seating that faces the window and they have very low sills in the Exeter library which I really love because you can sit down and it doesn't limit your view from waist high or from just below eye level up to the sky...your allowed to see what happens below too. That's nice.

Linda and Lora agreed on virtually every aspect of what a dream branch library might include. It would have good and plentiful light, lots of windows, and include a secluded area. It would also have a 'special' area. In Linda's case

this special area was a loft space while in Lora's case the special area was a courtyard.

It can be concluded, therefore, that the 'branch library' type has a fullness that is understood between at least some different designers, and that designers share a great deal of information about some types. Within a given culture, to at least some extent, there are universal types.

Lay, Novice, and Expert

As noted earlier, all of the participants who were given the dream library exercise understood and were able to answer the question. There were differences, however, in the depth of their answers. Linda, and especially Lora provided elaborate and rich descriptions of what would be included in their libraries. Darin, on the other hand, understood the type, but quickly exhausted his list of what might be included in the library. He said:

Well, if you were going to have some...I wouldn't say atmosphere, but you wouldn't want the place to be real drab and boring...which is hard to do because libraries are not known for their excitement.

Organized. Have it clean. Good location.

When pressed to say what he thought might prevent a library from becoming 'drab and boring,' Darin said:

Well I don't know...just maybe...livelier colors. Maybe like an art deco library. Mainly...pretty much colors. That's about it - all I can think of.

This difference in depth of understanding of the type indicates a difference between the lay, novice, and expert designers. Certainly both Linda and Lora had a more complete understanding of the type than Darin.

While it might be concluded that expert designers will always have a deeper knowledge of a greater number of types than will lay or novice designers, such a conclusion may be incorrect. It is probable that there are certain types of which the study group's lay designer would possess more knowledge than either the novice or expert designer. For example, his interest in basketball might give him a more complete understanding of the type 'gymnasium' than the other participants, neither of whom expressed interest in sports of any kind. Thus, had the exercise been to describe a 'dream' gymnasium, the lay designer might have shown greater expertise than either the novice or the expert designer.

• Case Three - Rules Derived From Types

The Problem

Participants are given Footprint Type D (reference figure below) and are told that it is for a building of no particular type. They are then asked to say which of the entrance locations they prefer and to explain their reasoning behind its selection. The participants are then told that the footprint is actually for an inner-city retail electronics store. They are then asked to say which of the entrance locations they prefer and to explain their reasoning behind its selection. Finally the participants are told that the footprint is for a suburban branch library. They are then asked to say which entrance they prefer and to explain their reasoning behind its selection.

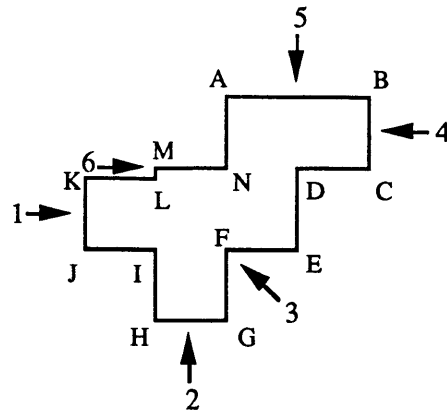

Footprint Type D

The Initial Goal

If, as Schön and Porter argue, rules are dependant on types, then I would expect to see participants change their preferences for entrance location when the building type is changed. Also, by starting with a building of no particular type I can discover a participant's tacit preference for entrance location and how this tacit preference informs his or her other choices. The decision to use an inner-city retail electronics store and a suburban branch library was made because of their radically different functions and settings.

Results

This exercise was quite successful in achieving its goals. Participants clearly understood the questions, and did not require additional directions. Only Darin seemed confused, and then only momentarily.

When asked what type of building she had assigned to the 'anonymous' footprint and which entrance location she preferred, Linda referred to the building as 'retail space' and selected entrance number five as her favorite. She was then told that the type was being changed to an inner-city retail electronics store, and was asked if the change effected her selection of entrance. She said:

Yes...you have to consider vandalism and walk outs. And so you're going to want to put the entrance where its very visible from all parts of the store or the space. And with that in mind the most central looks to be six. Maybe three. Three might be better. Yeah I like three better. Because from three you can see every place. Four's a little bit obscured from three, but that's all. You can have some kind of security there and you'd probably be OK.

Linda was then told that the building was changing to a suburban branch library and was asked if the change effected her selection of entrance. She said:

Yes - two. Because this big area back here (Rectangle ANCB in which entrance choices four and five are located) would be a good place to be quiet and be away from everything. One and six...that area could be storage or something. Two looks like a good reception area...good opening part...with a lot of space behind it for stacks or circulation, magazines, reading areas.

When the type was an inner-city retail electronics store Linda applied the rule that entrances must be 'visible from all parts of the store' and proceeded to select the entrance location which she felt best satisfied this rule. This rule had not been important when the building type was retail. When the building type was changed to suburban a branch library Linda applied the rule that entrances should be located such that they are remote from a 'quiet' area. This rule, which had not been applicable when the building was an inner-city retail electronics store, led her to select entrance number two.

Linda's case clearly supports the contention that rules are dependent on the types from which they are derived. In each instance when the type was

changed, the rules that led to her ultimate selection of an entrance also changed.

Lora was given the same exercise as Linda. Her tacit decision had been to look at the footprint as a house and to select entrance number one as her favorite. When she was told that the type was being changed to an inner-city retail electronics store, and was asked if this change effected her entrance selection, she said:

Yes! Definitely.

...An electronics store. Well chances are if they're going to have any windows at all they're going to pretty darn small.

...for crime reasons...for security reasons. So...when you say inner-city is there some sort of connotation of inner-city like a particular kind of inner-city or like Boston?

If it were Harlem maybe this was the entrance...number six.

OK, Definitely...no matter what three is usually a lousy choice if you have other choices. Forget three...so three and six are out.

...Ok well, I would say that five is the best entrance on this one because you get the most store frontage area...you have the potential for store front plus they can sell this little...

...Well there's the street, along the top of the sheet. You have your entrance there, you have the most area for store front, and just enough for some sort of a reception or check out area and then all this sales area for the rest of this form. Plus you either have the opportunity to have some sort of park or different layer..urban layer system like trees, benches, that sort of stuff (in the area

outside of ANK). Or you could potentially build-up in there too to make more of a street front line along in there.

When told that the type was being changed to a suburban branch library, and asked if this change effected her entrance selection, Lora said:

It definitely will effect my entrance selection, although I may pick the same entrance again, I don't know.

Well, if its in a suburban area and its a library then you definitely want a library to be friendly. So everybody will want to come in. So your going to really want to play up the entrance to a library...

...Well this way the (number) two entrance for this one has the potential of being kind of a cutesy little formal entrance of some sort. And libraries a lot of times can have pretty formal faces to the street...little civic buildings or something.

...the entry is going to be very important to a branch library, and its going to want to be slightly more formal than a house entry or a retail entry or something like that. So this is going to be too hard to make that work...too hard to make four polite. So, and three is of course always out.

I think this one, lets pick number two.

Like Linda, Lora's rules are dependent on the type she is referencing. When the type changed from house to inner-city retail electronics store she applied rules about security, store frontage, urban streets, and urban land usage. None of these rules was used when the type was a house. Similarly, when the type changed from an inner-city retail electronics store to a suburban branch library, she once again changed her rules about entrance locations. Rules

about 'friendliness' and formality of entrance, which were not mentioned as important for either of the other types, were important for the suburban branch library.

This example also shows Lora's expert designing to be different from the lay and novice designing of other participants. While the other participants clearly understood the concept of 'inner-city,' Lora's understanding was more complex as she broke the concept into at least two levels of meaning: high density and ghetto. The first level, 'high density,' implied a densely built-up area while the second level, 'ghetto,' implied not only a densely built-up area, but also an area that would be subject to a high incidence of crime. This ability to break the type into levels was not evident in the protocols of the other participants. Thus, when Lora considered a possible ghetto district, she indicated that entrance number six might be the proper choice because of security concerns. When told that the site was not in a ghetto district, however, the security concern was diminished and entrance number five was selected.

It is also interesting to note that Lora's rules about the possible use of entrances three and six were so strong that she stated under no condition would they serve as appropriate entrance locations. Her statement about entrance number six as a possible entrance in a ghetto district, however, would seem to indicate that the strongest rule, even when consciously manipulated to transcend type, may be subject to change if the type changes.

• Case Four - Discovery and the Seeing-Moving-Seeing Process

An example of discovery and the seeing-moving-seeing process is illustrated in Gilbert's design work on an expanded version of the branch library exercise. During this exercise Gilbert had been sketching and explaining how various axes he had drawn served to organize features of the site plan (reference Sketch 1 below). When asked where he planned to locate a particular site feature he said:

I haven't gotten there yet. I'm establishing (in Sketch 1) what I think is already given on the site based on what we've done.

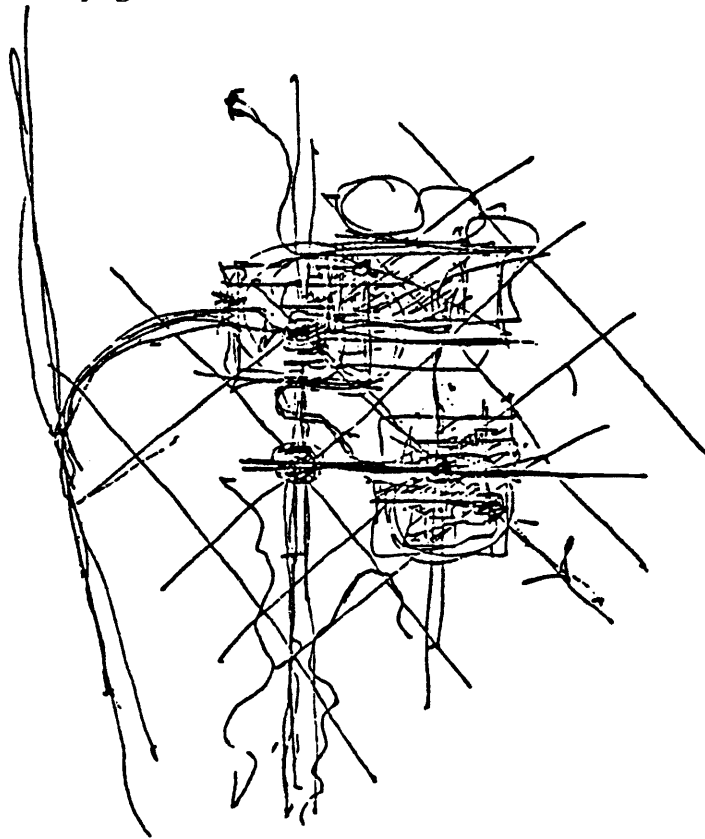

Sketch 1 - Gilbert

Gilbert, who had been using many layers of tracing paper, used the sketch to serve as a summary of his previous sketching and designing. He began a

new move experiment as he placed a clean piece of tracing paper over Sketch 1 and started to new sketch (reference Sketch 2 below). He said:

(Draws four circles to indicate nodes (a)) These would all be connected...adjoining. If its adjoining, its either adjoining in my plan that way, that way or that way. (Draws arrows in three directions from the dot in the lower right corner (b)) I'm going to respect the field that I've laid down. You have to have something to organize it and that's what I've used. (Connects nodes diagonally and horizontally (c)) By adjoining, I'm not sure that means they have to be architecturally connected with an arcade or whether it could be a door through a wall. But since they (the client in the exercise) haven't said, I'm going to make the assumption that it is not architecturally connected. It wouldn't be anything more than an arcade. All I know at this juncture...oh yeah! That starts working! Look what we're getting there, Mega-node. (Draws star where diagonal axes intersect (d))

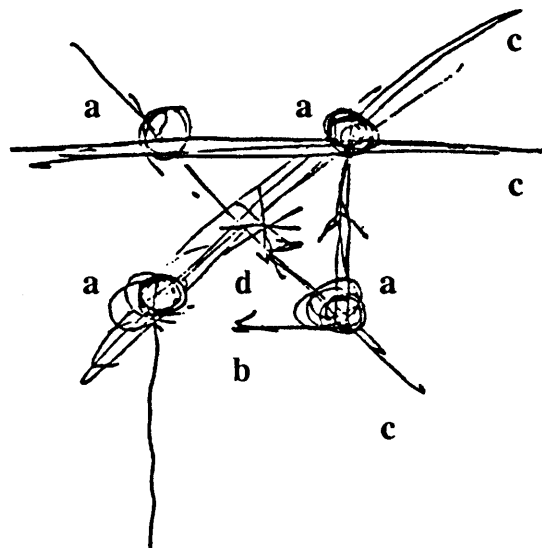

Sketch 2 - Gilbert

He then placed another piece of clean tracing paper on top of sketches 1 and 2 and began a new sketch (reference Sketch 3 below) saying:

(Places a fresh sheet of tracing paper over the previous sketches. Traces grid (a). Labels position of library, events and the site feature he had been asked about.) This is the library (b). This is an event (c). I'm going to tie this in with the entry in some way (d). This is the (site feature) (e).

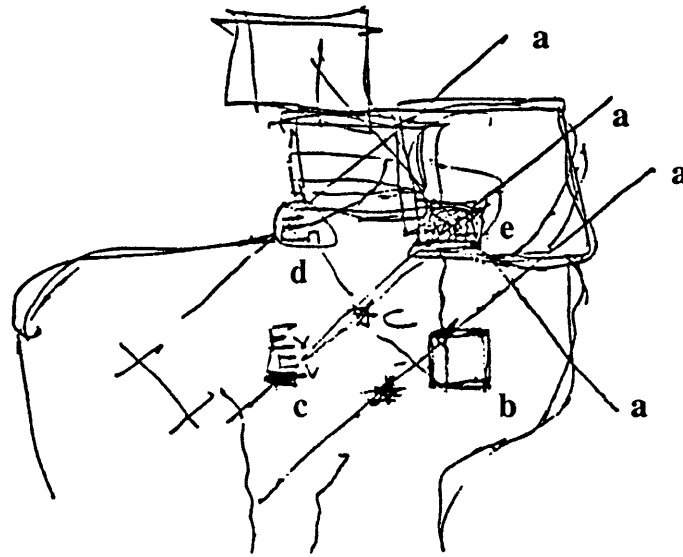

Sketch 3 - Gilbert

Gilbert began by reflecting on Sketch 1, which he had drawn as way of summarizing his previous designing and drawing. In seeing the sketch he both visually apprehended it and judged the quality of its configuration. He then placed a clean piece of tracing paper over it and began a new sketch, thereby initiating a new move experiment.

As he progressed with Sketch 2 he explained that he was drawing the site's nodes (shown by circles) along with their possible connections (shown by lines and arrows). He explained that by putting elements into 'fields' of this sort he could understand the materials of the problem. His move experiment was evidently one whereby he explored where to best locate the site feature he had been asked about. As he paused and reflected on the sketch, he saw that his

move had been affirmed as he discovered the 'Mega-node.' The mega-node must have matched a pattern with which Gilbert was already familiar: a pattern that gave him access to much more information than could be seen in the drawing. The implications of the discovery were immediately incorporated into his designing, as he began a new sketch (Sketch 3) and located the site feature he had initially been asked about.

Gilbert's case illustrates the process of discovery and seeing-moving-seeing. After completing Sketch 3 he continued on to a new sketch thereby continuing the seeing-moving-seeing process; making new discoveries as he designed.

• Case Five - Protocol Check - The Influence of Orientation

The Exercise

Exercise Number Five is composed of a number of primary and secondary footprints (reference figures below).

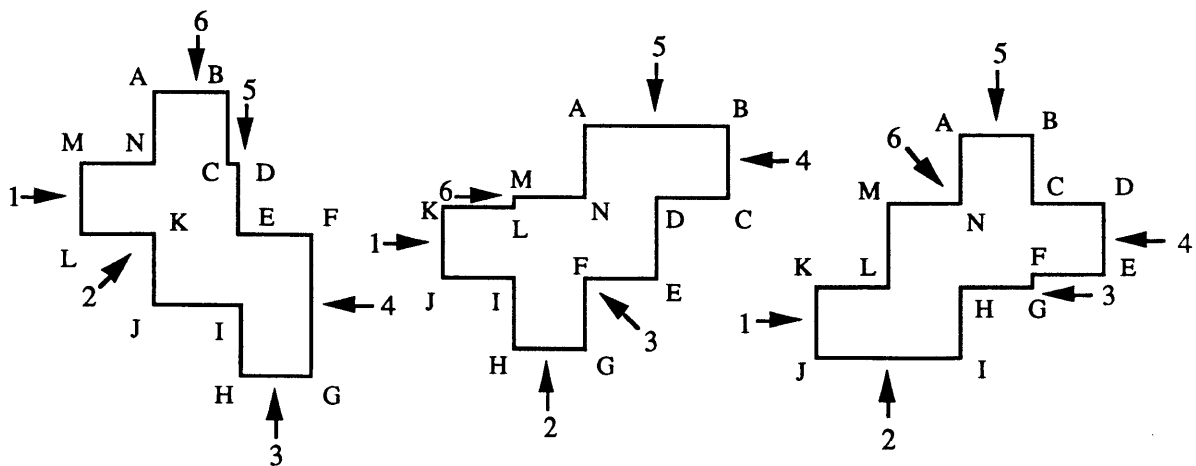

Footprint Type A

Footprint Type D

Footprint Type E

Primary Group

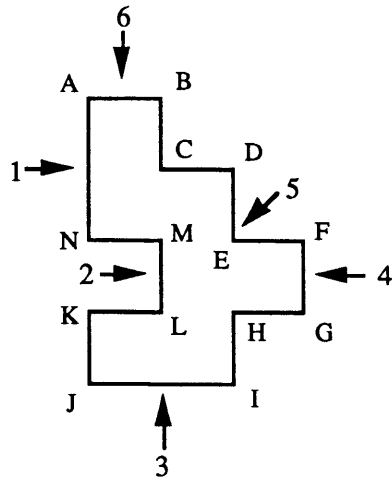

Footprint Type B

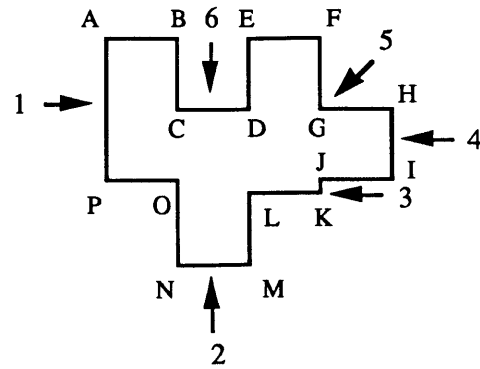

Footprint Type C

Secondary Group

This exercise consists of five individual parts which are scattered throughout the other exercises. In each instance participants are shown one of the footprints and told that it is for a building of no particular type. They are then asked to select their favorite entrance and to say where north and a street might be located. It was hoped that by scattering the footprints throughout the exercise process the participants would fail to see that the footprints from the primary group are identical to each other, but rotated on the sheet of paper. The secondary group, which consists of variations on the primary group, was introduced not only for the information on entrance selection it might provide, but also to further reduce the participant's ability to remember the configuration of the footprint in the primary group.

The Initial Goal

I speculate that when the original branch library exercise has been given in the past, that the orientation of the footprint on the sheet has influenced participants' approaches to, and eventual solutions for, the problem. For example, do some designers tacitly decide that north must be up? Do they

decide that a street must be orthogonal to the building plan? By testing these questions this exercise might provide information that could improve the manner in which future exercises with plans are designed and conducted. It is noteworthy, however, that on the original branch library exercise conducted by Porter and Schön, the results were not dependent upon whether or not the sheet presentation created a prejudice in a participant's mind.

Limitations of the Exercise

While conducting this exercise two major limitations became evident. The first limitation deals with the participants' recognition of the footprint from the primary group, while the second deals with a participant's conscious decision to select a different entrance location because of 'boredom.'

By the time the third variation (Footprint Type E) of the primary group was shown, the participants recognized it as a footprint they had previously seen, but rotated on the sheet. When shown Footprint Type E, Darin said:

...this is...isn't this the same drawing as the one I saw before...they look identical...

At the end of the exercise he asked:

The first, third, and fifth drawings (Footprint Types A, D, and E - the primary group) were the same weren't they?

When shown Footprint Type E, Linda said:

Looks like one I've already seen.

When Lora was shown Footprint Type D (the last in her series), she said:

This seems just the same only I think you're just twisting it around aren't you?

...Are they almost the same? Are you just rotating them? Is that what that means?

...Number one! Its just the same as number one...I knew you were just rotating it on the page to see if I'll make...to see if my thought process is consistent...I think that's probably what he's doing.

Lora, who was given the exercise after Linda and Darin, was only shown two footprints from the primary group (Footprint Types A and D). This adjustment was made because during the footprint's third presentation both Linda and Darin had recognized that they were being shown the same footprint rotated on the sheet of paper. By eliminating the third rotation I expected Lora to fail to notice that she was actually being asked questions about the same footprint. Interestingly, however, she noticed it as the same very quickly during its second presentation.

Another possible limitation of this exercise is seen through Lora's words and actions when she says:

The thing is is that I'm bored with naming that long side the entrance.

Of course the reasons for selecting an entrance are as important, if not more so, than the actual entrance selected. Thus, even though Lora became 'bored' with selecting the entrance on the 'long side' and therefore changed her selection, it is possible to study the reasoning behind her new selection to see if her design thinking also changed. This study indicates that regardless of the particular entrance chosen, Lora's reasoning for selecting an entrance

remained consistent for all of the footprint types. This reasoning, as discussed earlier, was consistently driven by her perception of a spatial gestalt composed of a central rectangle (KJED) with attached 'plug-on pieces' (IHGF and ABCN). When she became 'bored' and changed to entrance number one, she continued to perceive and reason upon this spatial gestalt.

Linda also recognized that she might be being shown the same footprint at different orientations. Her recognition, however, is much less pronounced than that of Darin and Lora. It is interesting that both Darin and Lora rotated each sheet that the footprint was drawn on and looked at it from a number of different orientations. For example, when they were given Footprint Type A, they both rotated the sheet as a part of their process, thereby producing the same view they would later see as Footprint Type D. That Linda did not rotate the sheet in this manner and thereby create the alternate views may have contributed to her less pronounced acknowledgment of the similarities in the plans.

When asked why she was rotating the sheet during her design process, Lora said:

Because...I imagine that this is a simple form. I imagine it in three dimensions as a simple, just blocked out form and what it would seem like when you approached this one.

When asked how this helped her she said:

Well it helps me imagine a real place. I think about...like probably a similar instance of approaching a building that has a similar entrance, or what I might perceive as a similar entrance in terms of the whole form and then I put myself there.

Rotating the sheet helped Lora to enter a 'felt-path' mode where she imagined what it was like to actually approach the building. She compared this imagined scene with a type already known to her to see if the proposed entrance would meet her criteria for a good entrance.

Results

Despite the limitations and surprises encountered in this exercise, it was still possible to obtain the type of information which was originally sought.

Lora's protocol, for example, indicates that the orientation of the footprint on the sheet does not necessarily influence all designers. In Lora's case this is at least partially attributable to her process of rotating the sheet on which the footprint is drawn. The fact that the alphabetic and numeric designations that appear with each footprint did not read correctly on the rotated sheet did not appear to effect her design process.

Linda, on the other hand, was greatly influenced by the orientation of the footprint on the sheet. Regardless of the footprint type under consideration, she always selected the top of the sheet for the direction of north. At one point she even referred to herself as a 'traditionalist' when making the selection. This comment probably stemmed from her knowledge that design professionals typically locate north to the top of the sheet on their drawings.

Linda's selections of preferable entrance locations for the footprints within the primary group may also have been influenced by sheet orientation. For Footprint Types A and D she selected the entrance which was located on the longest leg of the building's exterior (entrances four and five respectively). For Footprint Type E, however, she selected an entrance on a narrow leg. During her reasoning for Footprint Type E she indicated why she had not

selected the entrance on the longest leg by referring to the leg as 'too wide.' This process indicates an inconsistency in her design reasoning.

In addition to possible effects of footprint orientation, Linda's inconsistency might have been a result of her lack of professional architectural experience. Although she has worked as an interior designer, she has not worked as an architect. It is possible, therefore, that she has not developed a facility for this type of problem. This notion, however, is not supported by the results of Darin's protocol. Darin, who is only in his early teens and has no professional design experience, selected the entrance on the longest leg of the building each time the footprint in the primary group was shown to him. Orientation of the footprint on the sheet never influenced his selection. The reasoning behind his entrance selections was also consistent as each time he said, in slightly different words, that the longest leg would 'probably give you the most space.' Again, it is possible that Darin's consistency may be at least partially attributable to the manner in which he rotated the sheets on which the footprints were drawn, studying them from a variety of orientations.

This exercise illustrates that some designers may be influenced by methods of graphic presentation in design exercises. Certainly Linda's protocol illustrates that the orientation of the footprint on the sheet can influence the manner in which a designer approaches the design task. Lora's and Darin's protocols, however, indicate that by no means does orientation influence all designers.

Lay, Novice, and Expert

An unexpected result of this exercise was the manner in which the different levels of designers dealt with the task. Within the exercise the

participant was asked to look at each footprint and to say where north and a road might be. When Darin was asked this question for the first time he paused and said:

There's no way to know.

His reasoning was the same for all of the other footprint types. In no case did he say where north or a road might be. Linda, on the other hand, located a road and north for each of the footprints. In each case she located north to the top of the sheet and put a road in the front of the building face which contained her selection of entrance location. Lora also located a road and north for each of the footprint types, but in a significantly different manner than Linda. In each instance Lora gave extensive consideration to the factors effecting the building and the site. At one point while considering Footprint Type B she said:

If this is the entry...if three is the entry then this is the more private part of the space, perhaps. (The area around entry number six.) And the more private parts you are probably going to want to have...oh...then again it depends on climate whether you want a lot of east/west exposure or not. Its too hard to control it, so...I will either put north here or here. (Either at four or at one.) And, if its here...then sun goes this way...in the west...so in the morning they're not going to get any kind of exposure (mutters). But its the same...its pretty much the same thing only you get morning and no afternoon. Oh! Well my goodness. I've put a courtyard here (area around entry number two), so this has to be north. (To the right hand side of the sheet at entry four.) Because (the area around) two is a courtyard.

Lora's reasoning is complex and comprehensive. When she does pick north it is only after careful consideration of many factors: lighting of private areas, climate, interior daylighting, and exterior features. From the above information, differences between each of the three levels of designer can be seen. Darin maintains that it is not possible to solve the problem and therefore does not attempt to find a solution. For Linda and Lora, however, the problem is solvable. Apparently these more experienced designers possess an understanding of some schemata which is not a part of the lay designer's design world. Salient features of the problem that are apparent to the more experienced designers elude the lay designer. It is possible that Darin has not previously dealt with problems of this sort and has therefore not developed a method of solution. Linda, in contrast, has developed a method of solution. Her method, however, relies on conventions of the profession. In this exercise she follows the conventions very rigidly as she consistently locates north to the top of the sheet, regardless of where her entrance to the building has been located and without consideration of functions potentially occurring within the building. In her case it might be said that 'a little knowledge is dangerous.' In summary, the lay designer did not have the knowledge to solve the problem, the novice had an inappropriate knowledge for solving the problem, and the expert had an extensive and appropriate knowledge for solving the problem.

• Case Six - Protocol Check - The Influence of Scale

The Exercise

Participants are shown Footprint Type D (reference figure below) and are asked to select their favorite entrance location. They are then asked what the dimension of leg HG might be. No dimensions or scale indications are provided

with the footprint, so the participants have no clues beyond the materials of the problem itself for determining the dimension of the leg. Participants are then told that the dimension is actually thirty feet and are asked if this change effects their entrance preference. Finally they are told that the dimension is fifty feet and are asked if this change effects their entrance preference.

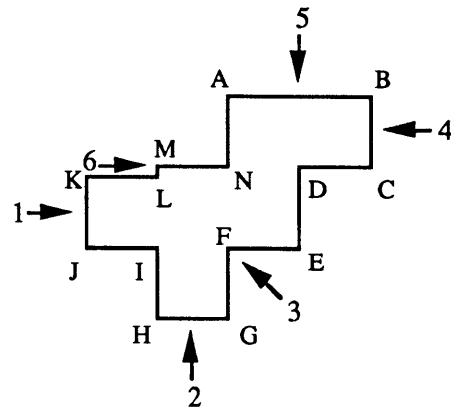

Footprint Type D

The Initial Goal

With this exercise I hoped to discover whether or not dimensional information should be included in design exercises that make use of footprints or similar graphic information. Do participants need to be given specific dimensions or a scale? If dimensional information is provided with the exercise, how might it influence a participant's design work?

Results

In addition to providing information which spoke to the initial goals described above, the results of this exercise also illustrated differences between the lay, novice, and expert designers in the group. Novice and expert designers did not require a dimensions or a scale. Although they frequently expressed curiosity about scale, they seemed to have a good tacit understanding

of what it might be. The lay designer, however, experienced difficulties due to the lack of dimension information.

When Darin was asked what the dimension of leg HG might be he said:

There's really no way of knowing what scale this is drawn to. You really can't say.

When pressed further he said that the dimension would be nine feet. Given that this dimension would also apply to the footprint's other similar legs, Darin's choice of nine feet is far too small. It is probable, however, that his poor choice of dimension did not influence his design thinking: it never occurred to him to consider how the small dimension of leg HG also created a building with tight spaces and an extremely low total square footage. Thus Darin's process was methodologically consistent and not effected by his understanding of dimensions.

Linda decided that the dimension would be twenty feet. When asked to explain why she had selected the dimension she said:

Because I'm still thinking store front I guess. (It would) Be enough for a door and some glass and some display maybe.

Although this hardly represents extensive reasoning about the building's requirements, it is substantially more than was used by Darin.

Lora was asked what the dimension would be on two occasions. On the first occasion she had considered the footprint to be for a house. She reflected on the question saying:

I'm thinking about what goes in an entrance to a house and like coat closets and maybe half baths and...and you don't want it to be

too big because you won't have anything to put there. Are these definitely walls? (Points to a line of the footprint.)

After reasoning through the problem she decided on a dimension of sixteen feet. Later in the protocol she was asked the same question, but for a suburban branch library. In this instance she decided on a dimension of thirty feet, saying:

I don't know..I'm picturing how big this...how big is this? Twenty feet? Twenty five feet? I'm thinking that it might be kind of nice if we have our check out area either here or...in Massachusetts your going to want to have a coat room because you don't want people dragging in snow and stuff and so were going to have to have an entrance here. I guess we would probably want (mutters) although...I'm trying to think about where the circulation desk would be, and I guess they usually need another space in the back of the library...I've never done a library so I don't know, but they probably need another little space for cataloging and wherever the librarians work. And I don't think its fair to stick the librarians in the middle where artificial light is because they're the people who have to be there all day long. I think they deserve natural light too. So I think the librarians will be here (at LMN). I was thinking that maybe it might even be possible to put circulation desk in here and then and if this were large enough (she gestures to IHGF)...since I'm picking a scale. But it would have to be awfully large in order to get things like coat rooms and book shelves...you know book cubby hole things for people or something to get all the criteria for the entry area of the building and circulation desk it might be a little bit cramped unless you made it absolutely humongous and then we're out of our branch library scale. So were going to put the circulation desk there.

Maybe we can have a coat room...if that's twenty feet...twenty, forty, sixty (she adds dimensions across the face of the building)...I don't really know how much room for books. Sixty feet though, about branch library size isn't it? Maybe not...maybe...twenty five, thirty, ninety (she adds dimensions across the face of the building). If it gets much bigger than thirty what the heck are you going to do with it all?

Thirty Feet.

Before deciding on a dimension Lora gave extensive consideration to numerous design factors. She considered sizes for a variety of functions including coat-rooms, a circulation desk, work space for the librarians, and shelving. She also considered appropriate sizes for a branch library. Her reasoning is much more advanced and extensive than that of either Darin or Linda. When Lora was asked to select a dimension, she thought about what functions would be located in the library and how much space these functions would require. Only with this process complete was she able to decide on a dimension.

The other expert designer in the study group, Corbin, also illustrated a more advanced type of reasoning than either Darin or Linda. Corbin was initially told that the footprint was for an inner-city retail electronics store and was asked which entrance location he preferred. After he selected entry number five he was asked to decide on a dimension for leg BC. He said:

I think BC would be about 25' and AB, which looks like twice the length of BC would be about 50'. That would make the total store around (does quick calculation with calculator) 3,700 square feet. That sounds about right.

Corbin was then told that the dimension of the leg was actually thirty feet and was asked if this change effected his preference for entry five. He replied that it did not. When the dimension was increased to fifty feet and he was asked if this change effected his preference for entry five he said:

That's getting quite a bit larger (does quick calculation with calculator)...15,000 square feet. That's big for just a store...and especially in an inner-city. Still, it could be a big deal...but the entrance...no, I still like number five.

Corbin used a calculator to figure the total square footage of the footprint based on the twenty-five foot dimension he had proposed for the leg. He understood that in assigning a dimension to one leg he was also assigning dimensions to the other legs. It is probable that he was familiar with an appropriate range of square footages for an inner-city retail electronics store and that he was checking his proposed sizes against these known ranges. As the dimension of the leg was increased his preference of entrance location remained unchanged. It can therefore be concluded that even if exact dimensions had been included with the footprints shown to the participants, the dimensions would not have influenced Corbin's entrance preference.

The results of this exercise indicate that as a designer's level of experience grows, so grows his or her understanding of scale and dimension. Darin was able to provide little reasoning for his choice of nine feet for the leg of the building. Although Linda was able to support her decision of twenty feet, her reasoning was limited. Lora and Corbin, on the other hand, provided extensive and complex reasoning for their selections.

In no way, however, did Darin's or Linda's lack of reasoning effect their approaches to, and understandings of, the problem. It can therefore be

concluded that regardless of a participant's experience level, dimensional information is not necessarily a critical piece of data that needs to be provided with future exercises similar to the original branch library exercise.

• Case Seven - Miscellaneous

In addition to the major cases already presented, there are also numerous miscellaneous cases that merit consideration. These miscellaneous cases are grouped together not due to any lack of significance, but because they are discussed more briefly than the previous cases.

Functional Types

Schön and Porter have stated that functional types consist of types of buildings or physical environments, or parts of buildings or environments. Further they claim that functional types are used primarily as sources of information to supply intermediate premises in chains of design reasoning. (Schön, 1988)

The results of the exercises show participants to have made use of functional types in a manner which would substantiate Schön's and Porter's claim. For example, the participants typically viewed an 'inner-city' site as one where security would be a concern. Corbin said:

In an inner-city area security is going to be a prime concern...

...I think the security from the outside would be easy to solve. You see lots of roll-down grills around here...bars would work, but I don't like bars.

'Retail electronics store' also carried implications for all of the participants. They knew that such a store would want display area to the exterior, and sales and storage areas on the interior. Participants also expressed concern about security and the monitoring of shoplifting. Linda said:

...you have to consider vandalism and walkouts. And so you're going to want to put the entrance where its very visible from all parts of the store or the space.

Similarly Lora said:

...An electronics store. Well chances are if they're going to have any windows at all they're going to be pretty darn small.

...crime reasons...security reasons...

The functional types 'inner-city' and 'retail electronics store' carried great meaning for the participants. Knowledge of the types provided the participants with access to information on items such as security and shoplifting which they were then able to take and apply to their own designing. Thus Schön's and Porter's notion is substantiated.

References

Earlier it was stated that references may be to particular buildings or particular kinds of buildings. Further it was stated that references can serve as either positive or negative examples. Participants in the exercises frequently made use of references. When asked what would be characteristic of her 'dream' library, Lora said:

...the Exeter library...The great thing about that library...is that you can see outside the window...not just when you sit down, but they have seating that faces the window and they have very low sills in the Exeter library which I really love because you can sit down and it doesn't limit your view from waist high or from just below eye level up to the sky...your allowed to see what happens below too. That's nice.

The Exeter library serves as a specific reference which Lora refers to for design guidance. In this instance it provides a positive example as it guides her design considerations for seating and sill heights of windows.

The same type of behavior is seen in Gloria's design process during her work on the original branch library exercise. When asked how she would go about working out the proportions of a particular space, she said that one would build models and do drawings. She also said that:

...You compare it with places you know. To give just one example, which is local, the Gardner Museum, in Boston, which has a courtyard, covered, which is just slightly higher than long. A lot of people like that place a lot; it's a real favorite, and it's not just because of the vegetation, which is very beautiful, and the way the facades are treated. It's because of the proportions of the space, primarily - the space is a vertical one.

In this instance the Gardner Museum serves as a positive example that Gloria can use to guide her designing.

The results of Gloria's protocol also illustrate how a reference can serve as a negative example. While designing the roof of her building Gloria said:

I don't know if you want a flat roof, because it would look like a filling station, or a Howard Johnson's, or something like that.

In Gloria's world the flat roof, as epitomized by the references 'filling station' and 'Howard Johnson's,' is something that should be avoided in the design of a suburban branch library.

Lora's and Gloria's protocols substantiate the claim that references are used in the design process, serving as guides for design reasoning. The protocols also show that references can be used as negative or positive examples.

The Felt Path Mode

Schön and Porter claim that experiential archetypes are frequently used when a designer is in the 'felt-path' mode, imagining what it feels like to be in or around a space. An example of this mode is illustrated in Lora's protocol. When asked why she was turning the sheet on which the footprint was drawn, she said:

Because I'm thinking about building approach.

...I imagine that this is a simple form. I imagine it in three dimensions as a simple, just blocked out form and what it would seem like when you approached this one.

...it helps me imagine a real place. I think about...like probably a similar instance of approaching a building that has a similar entrance, or what I might perceive as a similar entrance in terms of the whole form and then I put myself there. Like this one...even though I would not pick that one (number four). By looking at it this way I would not pick four.

In Lora's design world the felt-path mode is particularly important as it enables her to compare a possible design move with a known situation. In this instance she imagines what it is like to approach the building and then

compares this image with her previous experiences. This comparison provides her with a basis for negating or affirming a design move.

Design Canons

Earlier it was noted that a design canon refers to a set of rules or guidelines that can be used as a reference for proportions or formal geometries. An example from a protocol of the original branch library exercise further illustrates the use of design canons. While working on the branch library exercise Gloria, when asked about possible interior circulation for the building, said:

There are two ways of looking at it. This is almost a square (the whole original footprint), not quite, and my first inclination is to divide it into nine squares. The nine square configuration is classic. People write books about this. It's a typical pattern of outdoor space as well, if you look at the analysis of New England town commons, beginning with New Haven, Connecticut, you always get this as a starting point.

The 'nine square configuration' is a design canon that Gloria used in her designing. Its formal geometry guided her considerations of how the library's interior should be arranged. Ultimately this 'nine square configuration' was transformed into a 'twelve square configuration' which continued to guide her designing.

Fit and Misfit

Earlier it was observed that it is easier for designers to recognize a problem's misfits than its fits. This observation correlates with the actions of

all the participants in the exercises who, when asked which entrance location they preferred, started by naming and eliminating the entrance locations they did not like. While it might have taken the participants an impossibly long time to say what was right about an entrance, it was often a relatively quick and easy process for them to find at least one element of the entrance that constituted a misfit, thereby eliminating it from the selection process. For example, when asked which entrance location he preferred for Footprint Type D (reference figure below), Darin said:

...well...I know which ones I wouldn't like...

...I don't like number three because its on a corner and you really don't see it, and number six just doesn't seem like a big enough space...like crowding...

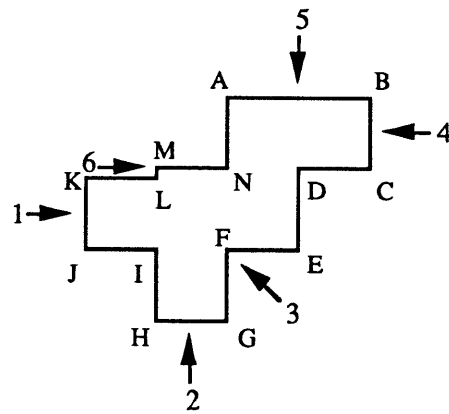

Footprint Type D

Darin considered entrance number three a misfit because of its corner position where it would not be seen. Entrance number six was a misfit as well due to its constricted space.

Undoubtedly Darin's notion of what causes a misfit comes from his appreciative system. Based on his past experiences he has come to appreciate,

for example, that an entrance located in a corner where it cannot be seen, or a crowded entrance with only a small amount of available space, is bad.

A similar example is seen in the results of Lora's protocol. When asked which entrance location she liked best for Footprint Type A (reference figure below), she said:

OK well, number two is the worst. Two is out - Five is out.

...because it's always awkward to have an entrance in the corner of a building because you - unless you have some sort of an additive thing there or its hard to delineate something that looks like an entrance at two.

Five looks like some sort of a service entrance or something like that. Same thing: you're not going to be able to make an entrance look viable there.

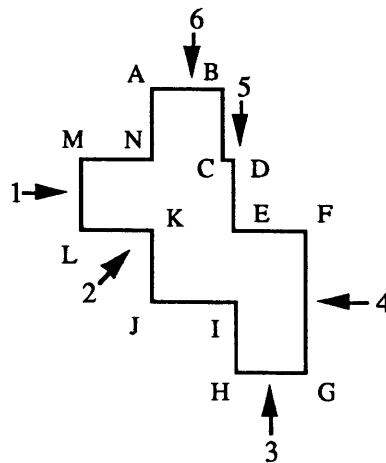

Footprint Type A

Lora needed only one reason to eliminate entrances two and five. Entry two was in a corner, thereby eliminating it, and entry five looked like a service entrance, thereby eliminating it.

Use of 'Bad' Types

Types can be used with methodological precision but still have a potentially 'bad' result. This 'bad' result, however, is tied directly to the spirit of the time. What is considered bad today may have been considered good in the past and may yet be considered good again in the future. Still when working on a particular project type, a designer is obviously working in the present. Thus when designers refer to projects from either the near or distant past, it is in their best interest to consider whether or not the types being referenced and appropriated will be considered good for the current project and a modern time.

For example, several of the designers who participated in the original branch library exercise made reference to Richardsonian libraries, carrying elements of this reference into their own work and allowing it to inform their designing. When working on the exercise Clara said that one of her processes was to supplement her design with 'different references to libraries.' She went on to say:

...Richardson is one of the references I would use very strongly for libraries. I think he does it really well. His tend to go two stories, though, so you can begin - if this were a two-story building, you could begin to add another layer to this. Maybe as you move in, this would be a stairway. You could actually move up, and have a whole upper level, and some larger piece of the massing, and have shelves up there, along the edge. Sometimes you can look out, sometimes you get a work space. You can move along that edge, up in the stacks...

Clara used the Richardsonian style of library as a guide for her own design work. Unfortunately her reference is to a style of library that, while quite

beautiful, is no longer considered appropriate by library professionals for the design of a modern library.

When Richardson was designing libraries in New England there were two primary schools of thought about how a library should be designed. The school that Richardson's work was a part of believed that the stacks of a library should be multi-stored galleries located around a centralized space. Problems with this approach such as spatial inefficiencies and poor expansion capacities led to its demise. The second school of thought, which promoted separate stacks, became the accepted standard in library design. Widner library at Harvard is an early example of this style of design. Thus, when Clara used the Richardsonian reference, she was accessing an inappropriate example for the design of a modern library. Even if she used the type with methodological precision, her design would still be informed by a 'bad' type.

A designer may quite correctly argue that there can be no qualitative absolutes. There can, however, be temporary versions of good and bad, and the designer who consistently makes use of what are considered bad types for a modern context may be faced with very dismal prospects for future design work. By no means, however, is this to imply that designers should compromise their visions of what comprises good architecture. It is instead to say that types should be reflected upon to see if they truly accomplish the designer's goal.

In the above example, it is unlikely that Clara was aware of challenges to the integrity of the Richardsonian type. If made aware of these challenges she might have chosen to be more reflective about what parts of the type she wished to appropriate. It is possible that her final design would have included only those elements of the type which have not been challenged by modern

library planning techniques. For example, had she referred to the style of fenestration in Richardson's libraries, her design would not have been adversely effected. Instead, however, she referred to his placement of stacks and the gallery: exactly the area where the reference becomes inappropriate.

Conclusion

In the introduction to this thesis I discussed a number of reasons why it is important to study design methodology. No doubt there are many ways that this study might have been undertaken, each with its own particular strengths and weaknesses. My goal has not been to describe a range of different methodologies, but rather to examine and be critical of a single methodology composed of a number of complimentary concepts. In being critical of this methodology I have attempted to judge both its merits and its faults; to analyze and evaluate it.

I therefore began by surveying much of the literature on the subject. From this survey I selected numerous concepts which I then studied in more detail and proposed as one approach to design methodology. Next I analyzed the results of a number of case studies which I and others had conducted and applied the findings to the proposed design methodology. These findings were used to test, clarify, and expand upon particular propositions made in the proposed design methodology.

• Conclusions About Design Methodology

Within the section of this thesis entitled 'The Cases' I have discussed in detail the results of my analysis of case studies done in conjunction with this thesis, noting how the results clarify, expand, or deny elements of the design methodology proposed in the first section of this thesis. Conclusions about these case studies are summarized here but without supplementary data.

An extensive investigation of spatial gestalts was done as a part of this thesis. It was observed that spatial gestalts are perceived rather quickly by designers and that these gestalts take precedence over the individual elements of which they are composed. It was also observed that spatial gestalts influence a designer's work at both a conscious and unconscious level. Finally it was noted that although new spatial gestalts can be consciously invoked by designers, it may be very difficult for a designer to escape the gestalt figure which he or she initially perceives.

These results indicate the power of spatial gestalts in the design process. That they are perceived so quickly, influence the designer's understandings of the problem, and are so difficult to escape once perceived illustrates their power.

An extensive investigation of the universality and cross applicability of types between different designers was also done as a part of this thesis. It was discovered that within a given culture at least some types have a universality for some designers. Conversely it was observed that different designers may refer to the same type, but have radically different understandings of the type's contents and significance. Thus, although two designers may use the same name to describe a type which they are using, the information that accompanies the name may be radically different for each of the two designers.

It was also observed that rules about designing are dependent on the types from which they are applied. Rules, which often appear to be independent of type, typically lose their applicability to a given situation when the type is changed. The strongest rule, even when consciously manipulated to transcend

type, may be subject to change if the type changes. Thus types take precedence over rules.

Discovery and the seeing-moving-seeing process was also investigated as a part of this thesis. It was observed that at least some designers make use of this process, allowing a gradual unfolding and evolution of design problems to occur in their work.

The use of functional types, references, and design canons was also observed in the results of the design exercises performed for this thesis. It was shown, for example, that references can serve as both positive and negative guides for a designer. The felt-path mode was also illustrated in the results of the design exercises. It was observed that in this mode a designer imagines what it is like to be in or around a space and then compares this image with his or her past or present experiences.

Notions of fit and misfit were also studied in this thesis. The processes of all the participants in my design exercises substantiated the claim that misfits stand out and are more compelling to designers than fits. This is because a misfit only required the identification of a single bad property while a fit might have required the identification of an impossibly long list of good properties.

The use of 'bad' types was also discussed in the thesis. It was noted that although there can be no qualitative absolutes, there can be temporary versions of what is good and bad. These temporary versions will necessarily be linked to the tastes and spirit of the current time. Thus a designer, by referring to a type that is no longer considered appropriate in the current time, may refer to a 'bad' type.

Finally a number of observations were made about differences between lay, novice, and expert designers. It was noted that current thinking about possible differences centers on the notion that the expert knows more than the novice. For example, it was seen that as a designer's level of experience grows, so grows his or her understandings of dimension and scale. Similarly, the expert was shown to have more complex and comprehensive knowledge than the lay and novice designers. While the less experienced designers might see a category of programmatic information as effecting only one level of design activity, the expert might see the same category as effecting numerous levels.

It was also observed that for certain design problems the lay designer did not have the knowledge to solve the problem, the novice had an inappropriate knowledge for solving the problem, and the expert had an extensive and appropriate knowledge for solving the problem. On the other hand, it was observed that expert status does not guarantee a designer that he or she will always have more knowledge than less experienced designers. For example, it was noted that although the lay designer had a limited palate with reference to some types, he might have had a richer palate than the expert for numerous other types.

Perhaps most revealing in the study of lay, novice, and expert designers, however, was the lay designer's ability to engage in the design process without prior architectural design experience. Despite his obvious limitations, he displayed an innate ability to design. Whether or not the same could be said of other lay designers is not addressed by this thesis.

• Conclusions About the Experimental Method

Given that design methodology was studied through a particular lens for this thesis, one might ask about the strengths and weaknesses of the lens. What was learned by studying methodology with the selected experimental method? What might be said about the protocol process? How does the experimental method effect the character of the data collected? How does it effect the overall study? What did I learn about the experimental method?

Results from the Exercises

Numerous aspects of the experimental method were tested as a part of the design exercises conducted for this thesis. Chief among these was a study of the manner in which graphic presentation of materials associated with design exercises might influence a participant's design work. Since the majority of the exercises used in this thesis make use of graphic information, this area of inquiry into the experimental method is of particular importance.

It was observed, for example, that the orientation of the footprint on the sheet of paper could influence a participant's tendency to perceive particular gestalt figures. Seen from one orientation, the footprint might lead the participant to perceive a particular spatial gestalt, while seen from a different orientation the footprint might lend itself to the perception of a different spatial gestalt.

Sheet orientation was also shown to influence how some of the participants related unspecified elements of programmatic information to the problem setting. For example, one participant's perception of where north should be located was guided more by the professional convention that north is typically

located to the top of a sheet than by functional or aesthetic considerations of the footprint.

Not all participants were influenced by orientation of the footprint on the sheet of paper. The fact that at least one participant was influenced, however, indicates a limitation in a part of the experimental method. This limitation should be considered in the design and analysis of future exercises.

It was also observed that when graphic information is used in a design exercise, it may not be necessary to include a scale or dimensions with the exercise. Although a number of the participants who engaged in the exercises had an inadequate understanding of spatial requirements and scale, their design methodologies were internally consistent and unaffected by these understandings.

A number of the exercises that I developed for this thesis were intended to test the results of previous research done at MIT and elsewhere. In several instances a participant in one of my exercises would more or less replicate the design behavior of a participant from a previous exercise which had been conducted by others. This replication not only served to verify and expand upon the results of the previous research, it also showed that the protocol process, while not tightly controlled or scientific, does provide results which can be replicated by other researchers. The ability to replicate results in research is important, and the replication of results from new and previous design exercises lends credibility to the protocol process as a method of conducting design research.

Limitations on Data Imposed by the Experimental Method

The data used for this thesis is taken from a number of protocols which were conducted both by my self and by others at MIT. The protocol process has both strengths and limitations in its ability to present an accurate depiction of a designer's process. Protocols are taken by giving a participant an exercise, asking him or her to 'think out loud' while designing, recording his or her words and drawings, and transcribing these recordings into a written format. The success of this process partially depends on the participant's ability to provide an accurate and complete picture of his or her design thinking. It is probable, however, that no participant will completely report the thinking that accompanies his or her designing. Thus protocols may provide incomplete data that fails to account for important aspects of the design process.

It is also possible that the request of a participant to 'think out loud' may effect his or her design process. It is difficult to determine, however, if this effect is of any consequence on the data. In any event, it is probable that a practice session for each of the participants might have better acclimated them to the 'thinking out loud' process.

A participant's process might also be influenced by the presence of an examiner during the testing process. Even if the examiner does not speak, there is a strong possibility that his or her presence will effect the participant. When the examiner actively interacts with the participant, the results will necessarily be effected.

The structure of the design exercises may also effect a participant's design work. For example, it is noteworthy that the data for this thesis was taken from a number of small exercises instead of a single, large exercise. Although this served the purpose of directing the participants' attention to my specific areas

of interest, it also forced them to 'jump' about in their designing focusing on a variety of design problems in a predetermined manner. A single, large exercise might have come closer in its ability to allow participants to engage in their normal design processes, but might also have failed to focus their attention on my specific areas of interest.

The protocol process, as used for this thesis, concentrates on the beginning, or early schematic phase of designing. Thus, although the findings of this thesis may have an applicability to numerous parts of the design process, the available data will only support the findings as they relate to the leading edge of designing.

This study is also limited in the number of participants who actually engaged in the design exercises. My approach was to concentrate on data from a limited number of participants. By concentrating in this fashion I was able to focus on a number of specific areas of interest as they relate to the design process. A different approach might have been to take a large number of samples and examine them for their overall implications on design methodology.

Finally one of the more striking limitations of the experimental method used in this study is its avoidance of qualitative design issues. This avoidance is not due to lack of personal interest, but rather because qualitative issues were out of the scope of what I wanted to examine. To have studied these issues would have required the creation of an exercise whose results could provide the type of data necessary for the study. My exercises were not designed to provide this type of data, although their results do provide implications for further study that might reveal methodologies capable of facilitating high quality design work.

Personal Issues Concerning the Experimental Method

I found the process of actually giving design exercises to participants very difficult. It was particularly difficult to ask questions in a way that would not influence a participant's responses. For example, in trying to get data that would allow a detailed study of spatial gestalts, I had difficulty deciding how to phrase a question that would encourage the participant to identify a gestalt figure in a footprint. After numerous trial runs of the exercise, each of which tried a different approach for getting the data, I settled somewhat uneasily on asking the participant to identify 'geometric patterns' in the footprint. In some cases, however, this phrasing did not make the question clear to the participant. In these instances I provided an example of a possible spatial gestalt by noting that some of the other participants had noticed a 'W' shape in the plan. When phrased in this manner, however, the question may be very leading to the participant. Lora, for example, when asked the question and given the example of the 'W,' diligently tried to locate a letter of the alphabet in the footprint. It was clear that the manner in which the question had been asked influenced her answer.

The question also arises about how and when to interrupt a participant who is working on an exercise. On several occasions a participant would engage in a process that I sensed might provide relevant and interesting data. Frequently, however, the participant would veer off of this path, and engage in potentially less interesting design work. Would it have been proper to interrupt the participant and ask him or her to continue working in the area which held my interest? I generally limited my interruptions of the design process. In reviewing the data, however, there were many instances where

interrupting the participant and asking a follow-up question might have provided important information.

Another thing I learned in performing the analysis of the protocols is that when referencing a passage from a protocol a participant's exact words should be used. While it is a temptation to paraphrase the participant, it is beneficial and truer to the process of unbiased analysis to provide direct quotations. By quoting, a reader is given the original data, and not an interpretation of that data. Paraphrasing necessarily interjects the paraphraser's own thoughts and prejudices.

Finally, one of the more revealing results of this study is my recognition of how difficult it can be to determine what constitutes a lay, novice, or expert designer. The range between a lay designer and an expert designer is difficult to describe with only one intermediate category. Also, the boundary that might be established for one type of design knowledge may be inappropriate for another type of design knowledge. When, for example, can it be established that a designer is an expert with regard to Experiential Archetypes or Spatial Gestalts? Problems also exist in the fact that this thesis indicates it to be probable for the lay designer's understandings of certain types to surpass those of the expert.

These issues of classification are not raised to argue for the abandonment of the three categories of expertise, but rather to indicate that there can be no hard and unyielding rules when considering differing levels of designers. In order to present findings and to explore concepts, the levels used in this thesis are reflections of each participant's experience level within the profession. Distinctions are not made based on the perceived qualitative expertise of the participant.

• Implications and Questions for Further Study

The line that separates a 'proficient' from a 'good' designer is placed in a highly subjective manner. To enter into discussions of quality is to invite debate. This is at least partially because all qualitative judgements are subjective and are necessarily linked to the tastes and spirit of the current time. A brief account of artists who were not appreciated in their own times, but who are now considered 'good' illustrates the situation.

In the process of executing this study a number of questions about methodologies that might produce 'good' instead of merely 'proficient' designers have been raised. As noted earlier, however, testing these questions is beyond the scope of this study and would require the design of an exercise as well as the assembly of a sample group that might be capable of providing the necessary data. Thus these questions, as discussed below, are left as implications for further study.

For example, earlier it was noted that there may be differences in the functional types that are known and understood by architects from distinctly different cultures and regions. Exposure to, and awareness of, a variety of functional types may contribute to the quality of design that a designer is able to produce. A paucity of functional types may be difficult for a designer to overcome. For example, it is possible that an architect from a sparsely populated area may have more trouble designing a good 'inner-city retail electronics store' than a designer who has spent much of his or her life in or around inner-city locations. The functional type 'inner-city' may not be real to the former designer.

Quality of functional types may also contribute to differences between good and proficient designers. In designing a particular project it is possible that

some designers will be familiar with, and make reference to, many quality examples, while other designers may be familiar with only a few mediocre examples. It is possible that the designer who refers to numerous quality functional types will produce a better design than the designer who refers to only a few mediocre functional types.

A similar argument might be developed with regard to appreciative systems. As noted earlier, appreciative systems are part of a designer's substantive knowledge and are developed throughout his or her lifetime. As a designer grows in experience and exposure, so will his or her appreciative system. As with types, it is possible that a wide variety of experiences with quality architecture may lead to the development of a quality appreciative system. Perhaps designers with quality appreciative systems will produce designs of high quality.

Earlier in this thesis it was claimed that at the beginning of the design process it is virtually impossible to say what will be included in a completed solution. Instead the process of designing involves a gradual unfolding of information which both informs, and is informed by, the designer's work. It is possible, therefore, that one of the measures of good versus proficient designers may be the degree to which they are able to let themselves go, and flow with the design 'stream.' Perhaps it is the better designer who does not attempt to force a fabric onto the design, but instead allows it to evolve naturally. Conversely, it may be the merely proficient designer who forces a solution onto a project very early in the design process. In opposition to the former designer whose process is one of discovery, the later designer's process would be one of justification.

Throughout this thesis the importance of sketching to the seeing-moving-seeing process of designing has been stressed. The very nature of sketches may help with the creative process as sketchy drawings have an ambiguity that allows the designer to see them in a variety of ways, thus leaving more room for discovery to occur. A drawing's level of completeness may also effect the way it will be engaged by a designer. Sketchy and ambiguous drawings, by their nature, do not allow the designer to focus on details. Instead they keep him or her at a more conceptual level. Precise drawings, in contrast, may remove the designer from the conceptual level and change his or her focus to detail-oriented issues. To enter into the detailed part of the design process before conceptual problems have been resolved may cause a design to be of lower quality than it might otherwise have been. Perhaps it is the better designer who understands the value of the sketch process and therefore does not attempt to rush into detailed hard line drawings.

This raises another issue that is relatively new to the architectural profession. Computer aided drafting and design (CAD) has become the norm for many of today's architectural offices. Initially used primarily in the preparation of working drawings, CAD is slowly being incorporated into the design phase of a project.

Designers note that the computer allows them to quickly study many options for the design of a building. For example, in the past a designer would study a building elevation by sketching it in a variety of configurations. The seeing-moving-seeing process was used during this sketching. The strength of this process was that it allowed the designer to have a conversation with the design problem. Its weakness was in the inability to reuse sketches as the project progressed. The same elevation might need to be re-drawn a dozen or more

times to reflect modifications made during the design process. CAD removes the necessity of completely re-drawing the same elevation each time it is modified. Instead modifications can be quickly edited into the drawing on the computer and printed onto a clean sheet of paper. Thus the drawings produced early in the design process can be reused as the project enters its design development, and ultimately construction documentation phases.

A danger of this process may be the manner by which it radically alters the sketching process which formerly allowed conversations between the designer and the problem to occur. The CAD process also provides hard line drawings in the schematic design phase of the project. Even when the designer takes the computer drawing and sketches on top of it with tracing paper, he or she is working with a tight and rigid drawing. The ambiguity and sketchiness that formerly led the designer to see new things and make unexpected discoveries is diminished.

• Implications for My Own Practice

To what extent can the notion of designing be extended? Although this thesis has focused on architectural designing, many of its propositions could find applicability not only to a number of other creative fields, but also to certain aspects of daily life which involve problem solution. This recognition has been one of the more significant results of this study for my own practice. The reflective process and an ongoing process of learning and understanding have come to have great meaning for me. For example, the actual process of creating and giving the exercises that provide much of the data for this thesis profited by a reflective process. As each participant finished the exercises, I reflected on the process, saw what had succeeded and what had failed, made

moves by revising parts of the exercises based on my reflections, and then gave the exercises to the next participant. Thus even the process of giving the exercises became one of seeing-moving-seeing.

I have also become more reflective about the manner in which I experience and understand pieces of architecture. I recognize, for example, that I can only refer to a type with which I am familiar. I therefore find myself eager to be exposed to a wide variety of quality types. The more quality types I have in my repertoire, and the more I am able to be reflective about these types and their constituent rules, the more likely my chances for overcoming obstacles and creating 'good' designs.

Explicit design knowledge has also proven useful for my design process. For example, I now realize that when I design I make use of a category of design knowledge that can be referred to as 'functional types.' When I encounter an obstacle during my designing, I am now explicitly aware of the existence and role of functional types in the design process and can therefore consciously use them to help me overcome the obstacle. Should functional types fail to help me I am further aware of, and can refer to, numerous other types of design knowledge.

My study has also shown me that appropriation is a natural part of the design process and should not be feared. In examining design methodology, it is striking how much of a designer's knowledge is based on his or her particular experiences. There are a tremendous number of subjective appreciations that combine to create an objective design world and it is likely that no two designers will ever inhabit exactly the same world. Thus when a particular reference is appropriated, it is immediately informed by the

designer's unique understanding of its significance. The appropriation therefore becomes a part of the individual designer's world.

It is not surprising that belief in individuality is one of the hallmarks of the architectural profession. Architects are taught to believe and design as if each project is an original, never seen before and never to be seen again. This teaching is no doubt valid, as most architectural projects are unique. It is not reasonable, however, to expect an architect to limit him or herself by avoiding references to other projects. Even architects who are considered, and proclaim themselves to be, absolutely original make references to other types, appropriating those aspects of the type that will help them. Whether these references are conscious or unconscious does not change the fact of the reference. Frank Lloyd Wright, for example, utilized elements of the Beaux-Arts tradition in his design of the Larkin building. The influences of eastern architecture and philosophy are also evident in his designs. It is impossible for a designer to completely avoid the influences of his or her own time and place. The question for the designer therefore becomes whether to appropriate references consciously or unconsciously.

Because it is impossible to avoid influences, and therefore appropriation, it is in a designer's best interest to be conscious of his or her appropriation. A conscious understanding will help the designer to be more intelligently guided by the references. Reflection will show that some aspects of a reference are appropriate for a particular situation while other aspects are not. Even if a designer decides that all of the aspects of a particular reference should be appropriated, his or her appropriation will still be incomplete. As Habraken has stated, it is impossible to list all of the constituent rules that make up any given type.

It should also be understood that appropriation does not imply a loss of creativity in a designer's work. It is unlikely that anyone would claim Wright's Larkin building, for example, was stylistically a part of the Beaux-Arts tradition in architecture, despite the fact that a careful study of the building will reveal a Beaux-Arts influence. In the earlier example of the designer who used a Richardsonian reference in the design of her library, it is unlikely that her final design solution would have had much, if any, resemblance to the library she was referencing.

Designers should not fear appropriation, but rather should welcome it for the information it brings to their design work. With reflective designing and a process of seeing-moving-seeing there is little danger that a final design solution will bear a significant resemblance to the appropriated reference. Appropriated types provide ideas, not dictates, for designers.

Finally this study has provided me with an improved understanding of approaches to education in architecture. In discussing my research with both students and professional architects, many have noted how their entire architectural education was one of fear. In their educations they came to believe that designers are 'born' and that architectural education's primary function is to reveal who has the innate talent to be a designer. Remarkd one student:

Each day I went to design studio with the hope that when I left I would still be a designer. The whole process was one of fear. We believed that we were like pieces of marble and that it was the instructor's job to chip all of the excess away until the the true person was all that remained. That person either would, or would not, be a designer.

Under this student's model of education, learning to design was not an additive process, but rather a stripping away process.

My study has shown that design skills can be taught and that no student should fear he or she might lack the ability to learn. At a minimum, 'design proficiency' is within the reach of anyone.

Education must deal with both substantive knowledge and process skills, stressing not only their individual characteristics, but also their intertwined nature. It is possible for a designer to have extensive substantive design knowledge, but to still have difficulty designing. Without process skills the designer has no way of engaging in the design process. While the designer may initially be able to express interesting ideas, he or she may be unable to transform these ideas into an integrated problem solution. Instead, the ideas may manifest in the design as isolated modules with little or no relation to each other or the context of which they are part.

It is also possible for a designer to have a great command of process skills, but to have little substance to actually process. In these instances the designer's work may come to lack variety. No matter how different the problems in the designer's career, each new solution may come to look and function like all the other solutions produced by the designer. This type of repetition would not be one of style, but of monotony.

Appendix - The Protocols

The following are the transcriptions of the protocols which provide much of the data used in this thesis. These four protocols were conducted in individual sessions lasting from twenty minutes to two hours. Each session was tape recorded and transcribed into this textual format. Although each of the participants was provided with tracing paper, newsprint, and a variety of pens and pencils, no sketching was performed.

The participants all saw the footprint in the same format. All footprint types were drawn at the same scale by a computer. Each drawing was put onto an 8 1/2" by 11" sheet of paper, more or less filling the page.

January 1989

GW: I am going to ask you a number of questions. Some of them may seem silly and some of them may seem more serious than others, but they are all serious. The questions are looking for different things and you need to realize that there are no right and no wrong answers. There are no tricks built into the format: the point here is to study how people think when solving architectural problems. Some of the questions may be answered quickly while others may take a bit longer. There is no rush. If you look at a question and you do not have an answer, it is acceptable to say so. Similarly, if I present you with alternate answers to a question you may decide that it does not matter which alternative is selected. It is acceptable to say that you do not feel that it matters which option is selected. You may draw if you like: I have tracing paper you can use as well as a variety of pens. This session is very free form. The only thing that I request that you do is to think out loud. Rather than internalizing your thought process I want you to verbalize everything that you are thinking as you work through these problems. I will start to pry if I recognize that you are thinking without verbalizing.

GW: This is Footprint Type D - it is the floor plan (see figure below) of a retail electronics store which is located in an inner-city area. - not in a ghetto, but in a densely built-up area. These arrows represent places that you could possibly enter into the building.

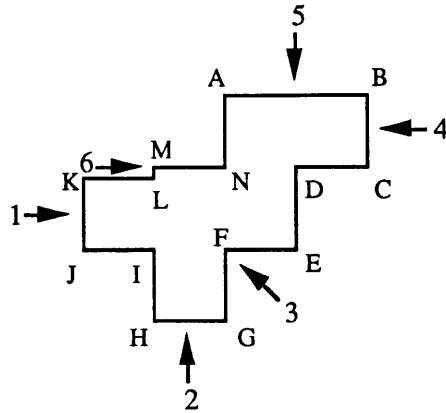

Footprint Type D

Which of these entrances do you think would be best?

CM: In an inner-city area security is going to be a prime concern...and its being an electronics store only intensifies that concern. Still, since it is a retail store it will want some display area to the street. One also wants to think about what is going on on the inside of the thing.

Number six and three probably won't work because in an inner-city area one (a person) is probably going to find other buildings or functions stuck into these corners...they don't make very good street front.

That leaves (entrance numbers) one, two, four, and five. Any of them would probably work. If this were a severe crime area one (a person) would probably not go with five because of all the exposure. Since its not a ghetto though...I think five would be best.

Five is still an easy location to monitor in terms of entrance and exit to the store. It also gives one a front sales area that is different from the rest...there

could be blank tapes in this (ABCN) section along with some of the lessor expense items...walkmans...also the cashier of course. Then as you moved back in the plan you could have more expensive areas with perhaps a very exclusive room here (KJIL). The storage area could go here (IHGF). That would probably work good...if there were to be a rear entrance for deliveries it would probably be from an alley or something which would in all likelihood be parallel to the main street in front.

Five also gives good display area to the street (along AB), and I think the security from the outside would be easy to solve. You see lots of roll-down metal grills around here...bars would work, but I don't like bars.

GW: Great. Now tell me, since you've picked number five as your favorite, and you have talked about what goes on in here (ABCN), what would you say the dimensions of AB and BC are?

CM: Well, this is drawn pretty precisely, so I'm sure that you have a scale in mind...

GW: Don't worry about what scale I use. Just say what you think are the best dimensions.

CM: I think BC would be about 25' and AB, which looks like twice the length of BC would be about 50'. That would make the total store around (does quick calculation with calculator) 3,700 square feet. That sounds about right.

GW: What if I tell you that BC is really 30' and that AB is really 60'? Does that change your selection of entrance?

CM: Not really. That's not a big difference.

GW: What if I tell you that BC is 50' and that AB is 100'? Does that change your selection of entrance?

CM: That's getting quite a bit larger (does quick calculation with calculator)...15,000 square feet. That's big for just a store...and especially in an inner-city. Still, it could be a big deal...but the entrance...no, I still like number five.

GW: So it doesn't change your thinking?

CM: No.

GW: In looking at this plan and working on the entry selection, did you see any geometric shapes?

CM: Yes...To me this plan is composed of two L shapes...here (ABCDEF) and here (NGHIJK).

GW: How would you say that recognizing those shapes influenced your selection of an entrance?

CM: Well I don't know that it did influence which entry I thought was best...maybe. Its hard to say how it did influence me...maybe it didn't. On the other hand, as I think about it I can see that I thought of the front of the store in terms of this L shape (that entry number five is a part of), and the back, or more exclusive part of the store in terms of this L shape (the other L) - but I don't know.

I could stretch and say something, but that's not what you want is it?

GW: No - what you've done here is fine. Thanks a lot.

Biographical Information on Corbin

Corbin currently lives in Boston Massachusetts and is attending MIT's school of architecture. He is a licensed architect from overseas and has practiced architecture extensively in his native country.

Corbin is in his late twenties and was raised in a suburb of a large city where he lived most of his life prior to moving to Boston.

Corbin has traveled extensively in Europe. He has traveled a small amount in the eastern and mid-western United States.

January 1989

GW: I am going to ask you a number of questions. Some of them may seem silly and some of them may seem more serious than others, but they are all serious. The questions are looking for different things and you need to realize that there are no right and no wrong answers. There are no tricks built into the format: the point here is to study how people think when solving architectural problems. Some of the questions may be answered quickly while others may take a bit longer. There is no rush. If you look at a question and you do not have an answer, it is acceptable to say so. Similarly, if I present you with alternate answers to a question you may decide that it does not matter which alternative is selected. It is acceptable to say that you do not feel that it matters which option is selected. You may draw if you like: I have tracing paper you can use as well as a variety of pens. This session is very free form. The only thing that I request that you do is to think out loud. Rather than internalizing your thought process I want you to verbalize everything that you are thinking as you work through these problems. I will start to pry if I recognize that you are thinking without verbalizing.

In architecture there is something called a floor plan or a footprint. In this house its just what the floor looks like. Are you familiar with floor plans at all?

DK: Oh.

GW: If we have a plan of this room it would look something like...(draws plan of room the protocol is being given in as an example).

DK: Oh yeah. OK. Alright.

GW: So what we're looking at are going to be floor plans of an entire building. I'm going to show you a number of plan types and ask you a few questions about them. These arrows indicate places that you could choose to put the entrance into the building. So you could have your main door into the building (at any one of the points).

DK: OK

GW: Alright. (Reference Footprint Type A Below)

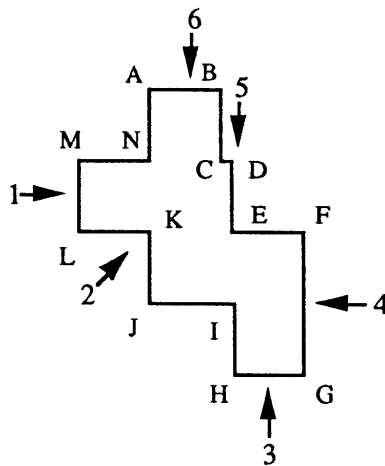

Footprint Type A

This is Footprint Type A. The building is of no particular type. I want you to tell me which entrance you like the best.

DK: Um...well...I know which ones I wouldn't like.

GW: We can eliminate them. You can talk through and eliminate

DK: I don't like number two because its on a corner and you really don't see it, and number five just doesn't seem like a big enough space...like crowding. I don't see really much difference between three, six, and one. Four would probably give you the most space.

GW: OK, so you're going to let four be your favorite.

DK: Yeah.

GW: Alright. Do you have any sense when you look at this if there's a road any where around this building?

DK: A road? Well, it could be...I don't know.

GW: Do you have any idea which way north might be?

DK: No.

GW: OK, that's fine. That was the first one.

DK: There's no way to know.

GW: This is the second one. (Reference Footprint Type B below)

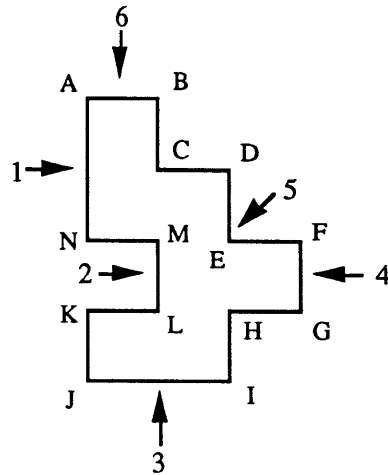

Footprint Type B

I want you to look at this and tell me which entrance you like the best.

DK: One...because it gives you the most space and this (five) is on a corner and six and four are pretty much the same. But this one (one) will give you a lot of space,

GW: When you say space what do you mean?

DK: Well I mean...you won't feel crowded when you enter in...there will be room.

GW: Do you have any idea if there's a road anywhere around this?

DK: No.

GW: How about north? Any idea where north might be?

DK: No.

GW: OK, good. These floor plans are all kind of variations on each other - they're similar. Alright, now I want you to look at this one (Footprint Type D - Reference figure below) and tell me first which entrance you like the best.

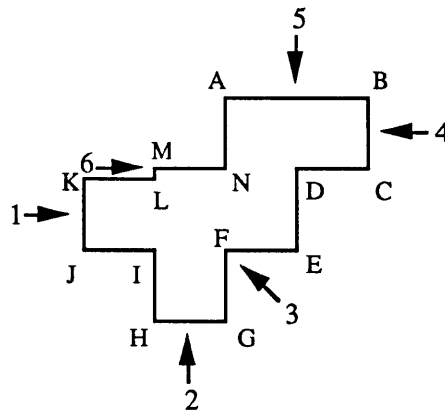

Footprint Type D

DK: Well I have to say number five because...the same reason as before. This one (six) looks kind of...too small...four, two, and one are pretty much the same thing (?), and number three is on a corner.

GW: Alright. Do you have any idea if there's a road around here?

DK: No.

GW: North?

DK: No.

GW: Alright. Now lets look at...on this same plan what I want you to do is to look at this and tell me...when I've been asking you these questions on entrances, have you had any ideas about what type of building this might be?

DK: Um...an office building.

GW: So you've thought to yourself its an office. Alright. So without having a type given you came up with office. Now I want to tell you that this is now an electronics store that sells electronics gear. TVs, stereos, hi-tech - maybe some computers, and that its located in the inner city, an urban area. Does that change where you would put the entrance at all? Its not an office building anymore. It doesn't have to: its just a question.

DK: Well, no.

GW: OK, so you still like five the best. Now lets say that this building is a branch library that's located in the suburbs. Do you know what suburbs are?

DK: Yes.

GW: OK. Its located in the suburbs. Does that change your thinking any?

DK: Yes. I would make two because, I mean you could...because you really don't need room. All you have to...and that's the way libraries are set up. You could have a desk there.

GW: So you changed to two when its a library.

OK. Now I want you to tell me which, if any of these entrances, is a jailor's entrance.

DK: Janitor?

GW: Jailor. A jail. An entrance that someone who has a jail would like.

DK: Six. If this was a jail, well I don't know. If these people are criminals and they're in the jail, you don't worry about them being real comfortable entrances. So I would say six.

GW: Alright. Lets go ahead and do one more with this one (Footprint Type D). When you look at this...we're not thinking of entrances now - we're changing off, so you don't have to pay any attention to the arrows. When you look at this do you see any geometries? Do any geometrical forms or shapes come to you?

DK: Well it has a lot of square properties. You know...it all seems to be...everything's parallel to this side and everything's parallel to this side (indicates the major x/y axes).

GW: When some people look at this they see a W shape. Do you see a W in it?

DK: I can see one - yeah.

GW: Do any others come to you?

DK: I can see a Y. Doesn't form...perfect. And something else...a T. (Indicates KDEFGHIJ) Well that's pretty much all I can see...well you could get an L. (Indicates back to back Ls formed by NGHIJK and ABCDEF.)

GW: Now I want you to try to look at this and tell me what you see. Does any one of the geometries we've talked about jump out at you?

DK: What letter?

GW: Of anything we've talked about.

DK: I would say the W is the most prominent.

GW: Alright. Just out of curiosity. This leg at entrance number two..(HG), how many feet would you say that is long?

DK: There's really no way of knowing what scale this is drawn to. You really can't say.

GW: Take a stab.

DK: Well if its just a normal entrance way I would say maybe three and a half feet for the doorway.

GW: No...the whole leg...from the points at either end.

DK: Um...nine feet.

GW: Alright. This is Footprint Type C. (Reference Footprint Type C below.)

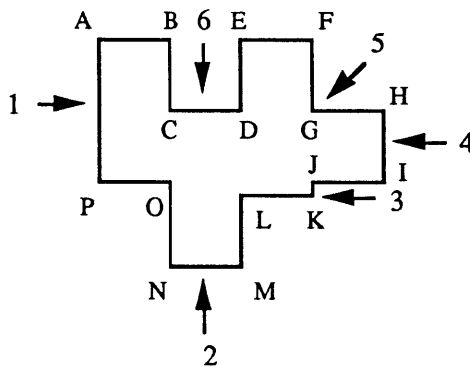

Footprint Type C

Which entrance do you like the best?

DK: Six.

GW: Why?

DK: Well because you could really make a nice looking house and garden or something coming up this side and this could be the...you see buildings like this. I think six would be a good entrance.

GW: Is there a street anywhere around it?

DK: Well there's really no way of knowing.

GW: Is north any direction?

DK: No.

GW: OK. This is Footprint Type E (Reference Footprint Type E below)

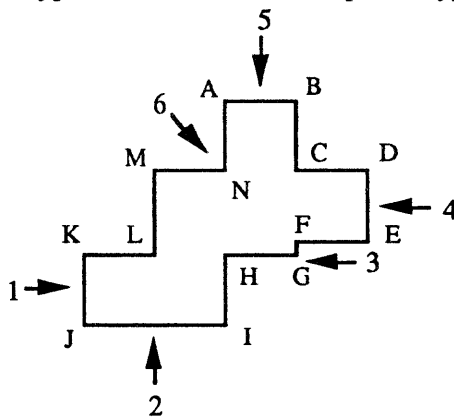

Footprint Type E

Which entrance do you like the best.?

DK: Two. This is the...isn't this the same drawing as the one I saw before...

GW: They're similar.

DK: Similar! They look identical! Well, this one (two) gives you the most room.

GW: Is north any direction?

DK: No.

GW: Is there a street anywhere?

DK: No.

GW: OK, now the last one. What I want you to do is to think about a branch library. You were talking a little bit earlier about how you would put an entrance in a certain location because of what went in...If you were to sit back and dream in your own mind, not based on anything, but just in your own mind, what it was that made a perfect branch library, what would that be? Just talk freely.

DK: Well, if you were going to have some...I wouldn't say atmosphere, but you wouldn't want the place to be real drab and boring...which is hard to do because libraries are not known for their excitement.

Organized. Have it clean. Good location. (?)

GW: When you said drab and boring, what would be something that would keep that environment from being drab and boring?

DK: Well I don't know...just maybe...livelier colors. Maybe like an art deco library. Mainly...pretty much colors. That's about it - all I can think of.

GW: When you talked about organized, what does that mean to you?

DK: Well it means that all the books are in the right place and the librarians know where the stuff is...that kind of stuff...they don't...they know everything about it.

GW: Alright, thanks.

DK: The first, third, and fifth drawings (Footprint Types A, D, and E) were the same weren't they?

GW: Yes.

DK: I thought they looked familiar.

Biographical Information on Darin

Darin is currently attending high school as a ninth grade student in the San Antonio Texas school system. His interests are far reaching from sports to academics.

Darin is 14 years old and has been raised in a suburb of San Antonio for the majority of his life.

Darin has not traveled extensively in or out of the United States, though he has had a few vacations to other areas.

January 1989

GW: I am going to ask you a number of questions. Some of them may seem silly and some of them may seem more serious than others, but they are all serious. The questions are looking for different things and you need to realize that there are no right and no wrong answers. There are no tricks built into the format: the point here is to study how people think when solving architectural problems. Some of the questions may be answered quickly while others may take a bit longer. There is no rush. If you look at a question and you do not have an answer, it is acceptable to say so. Similarly, if I present you with alternate answers to a question you may decide that it does not matter which alternative is selected. It is acceptable to say that you do not feel that it matters which option is selected. You may draw if you like: I have tracing paper you can use as well as a variety of pens. This session is very free form. The only thing that I request that you do is to think out loud. Rather than internalizing your thought process I want you to verbalize everything that you are thinking as you work through these problems. I will start to pry if I recognize that you are thinking without verbalizing.

Do you know how to read a floor plan?

LH: Yes.

GW: I am going to show you a number of plan types and ask you a few questions about them. OK. (Reference Footprint Type A Below)

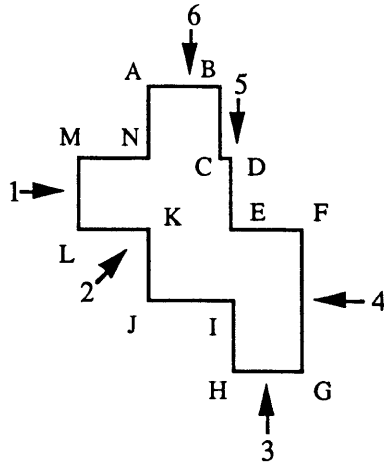

Footprint Type A

This is Footprint Type A. These arrows represent places that you could possibly enter the building. The building is of no particular type. I want you to tell me where you think the best place for the entrance is.

LH: Well I think the best place for the entrance...there's only one entrance?

GW: Only one...what are you thinking?

LH: Well, two is more central, but its in the corner. And that offends me aesthetically. Six is pretty central, but I like four the best and I don't know why.

GW: So you like four best. Do you have any sense of where a road might be?

LH: I have a feeling the road's right out here in front of four. (the right hand side of the sheet)

GW: Alright. Do you have any idea which way north might be?

LH: Six (the top of the sheet) is north.

GW: OK, (Reference Footprint Type B below)

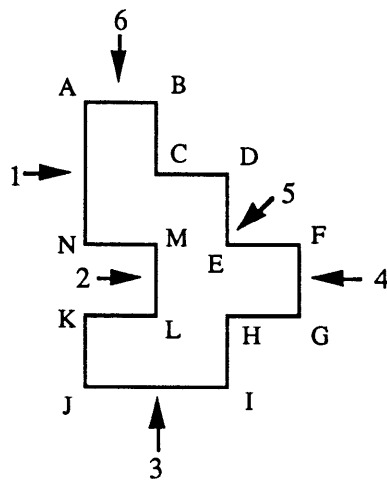

Footprint Type B

What's your favorite entrance?

LH: One entrance?

GW: One entrance.

LH: Four, because I visualize a road running along beside it.

GW: OK, what about north?

LH: Six (the top of the sheet) is north. Traditionalist.

GW: Alright. (Reference Footprint Type D below)

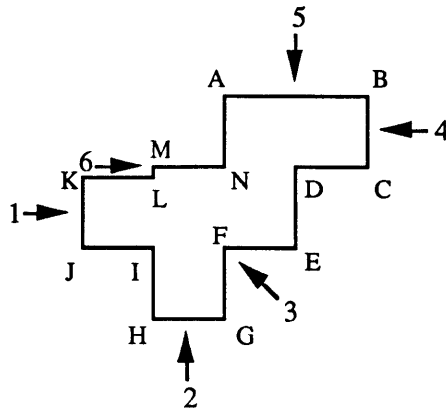

Footprint Type D

What's your favorite entrance?

LH: Five. Because that's the street front. Five is the street front.

GW: So the street's running parallel (to the top of the sheet)? Where's north?

LH: Five (the top of the sheet) is north.

GW: OK, now, lets look at this one just a little bit longer. In looking at this I've been asking you so that its not a building type. Have you in your mind made it any sort of building type?

LH: No...store front maybe.

GW: So you haven't assigned any function to it?

LH: Retail space, maybe...but...

GW: OK, what I want to do now is tell you that this is an electronics store. Its located in an inner city area. So it sells stereo gear, TVs, computers, and its located in an downtown or inner city area. Does that influence any of your thinking about where you want to place the entrance?

LH: Yes.

GW: Speak to me...what are you thinking?

LH: Well you have to consider vandalism and walk outs. And so you're going to want to put the entrance where its very visible from all parts of the store or the space. And with that in mind the most central looks to be six. Maybe three. Three might be better. Yeah I like three better. Because from three you can see every place. Four's a little bit obscured from three, but that's all. You can have some kind of security there and you'd probably be OK.

GW: OK, so three is your choice. Now lets change it again. Lets say that this is a branch library and that its located in a suburban location. Does that influence your thinking?

LH: Yes - two. Because this big area back here (Rectangle ANCB in which entrance choices four and five are located) would be a good place to be quiet

and be away from everything. One and six...that area could be storage or something. Two looks like a good reception area...good opening part...with a lot of space behind it for stacks or circulation, magazines, reading areas.

GW: Alright. One last question on this plan. If I were to tell you to go through these entrances and look at them and pick what you would call a jailor's entrance...

LH: I don't understand the term.

GW: An entrance that a jailor...someone who works in a jail...a jailor. Would you consider any of these a jailor's entrance.

LH: Six.

GW: Why.

LH: Because its narrow. Its the only little bitty angle like that. There's a solid wall, I assume, that's right on both sides of it. (Legs MN and KL either side of six.) I guess this is solid and so is this. They look like they'd be solid. It looks like it would be narrow and creepy.

GW: OK (Reference Footprint Type C below)

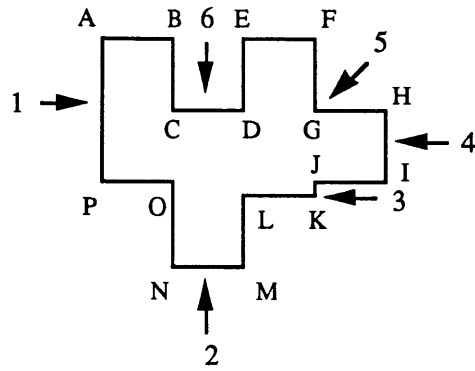

Footprint Type C

What is your favorite entrance?

LH: Two. I don't know why.

GW: Think out loud about why you think it is.

LH: Because it looks like the rest of this (?) was designed for space and two is sitting there reaching out in front of the structure.

GW: Where's the road?

LH: Its still in front of two. (The bottom of the sheet)

GW: Where's north?

LH: Six. (The top of the sheet)

GW: OK, look at this from point N to point M, which is the leg that entrance number two is on. What dimension do suppose that is?

LH: (Mutters) Maybe twenty feet.

GW: Why?

LH: Because I'm still thinking store front I guess. Be enough for a door and some glass and some display maybe.

GW: Now lets think just a second. Nothing to look at this one. I want you to think about this idea of the branch library. Close your eyes and imagine...no rules...the perfect - the dream - branch library.

What would be characteristic in your mind of the perfect branch library?
What do you think of?

LH: We're not talking about an academic thing I have to do for a paper? Just a branch in a neighborhood?

GW: Pure dream.

LH: A lot of space...a lot of...maybe a lot of glass with a lot of light coming down. Comfortable seating...some secluded areas that you can read. Maybe even a loft...something like that where you could...just the reading rooms...with comfortable seating.

GW: OK, you've talked about seclusion. Why is seclusion a good thing?

LH: In a neighborhood library there are always a bunch of little kids and you can't sit and read or study or do anything unless you can get away from them. There needs to be an adult's section and a children's section - secluded back - away.

GW: OK. Lighting - why is lighting good?

LH: You need lighting to read. I like natural lighting anyway.

GW: When you talk about lots of space what does that mean to you?

LH: I'm visualizing a lot of overhead space but that goes with the lighting. It gives you a feeling of intimacy when you're working somehow. I don't like to be closeted. I like the spacey - open feel...the one that looks like its cool. Its so spacious it looks cool but not cold.

GW: So your thinking volumetrically?

LH: Yes.

GW: OK. The last one of these. (Reference Footprint Type E below)

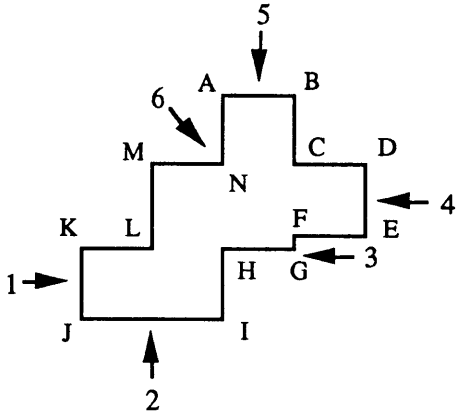

Footprint Type E

Alright. What's your favorite entrance?

LH: Looks like one I've already seen. My favorite entrance. Well number two's too wide...number three's too narrow...lets go with number four...because its just right...its sticking out there...I don't know...

GW: Where's the road?

LH: I still think the road's in front of number two (to the bottom of the sheet) - that was my first impression anyway.

GW: Where's north?

LH: Number five (to the top of the sheet).

GW: OK, in looking at this plan do you see any geometric forms?

LH: There's a W...(She gestures to the W shape.)

GW: OK, anything else?

LH: Not really.

GW: When you see that W...how quickly when I put this down did you perceive a W?

LH: Pretty quick. I see the shapes before I look at the whole thing.

GW: Do you suppose that W has anything to do with picking number four?

LH: Could be...I hadn't thought of that, but since number four's at the bottom of the W...

GW: Why don't we play that out a little bit, just think through it.

LH: But see if that was the case I'd make a new entrance...six is here?

GW: Six points to that corner.

LH: OK - to the corner. See I would put a entrance right here (points to leg MN near the corner where six is indicated) between six and wherever the center of the W. That appeals to my sense of order.

GW: Alright, well thank you. (Note that although Linda was supplied with tracing paper and drawing tools, that she did not draw during any part of the process.)

Biographical Information on Linda

Linda currently teaches learning impaired children in the San Antonio Texas school system, though she is trained and has worked as a professional interior designer in the past. She has a degree in interior design from a college in Texas.

Linda is 38 years old and was raised in a small town near Amarillo Texas. She lived there until she entered college in a medium sized town near Dallas Texas. From there she moved to south Texas and eventually to San Antonio where she left the interior design field to enter the teaching profession.

Linda has not traveled extensively either in or out of the United States.

January 1989

GW: I am going to ask you a number of questions. Some of them may seem silly and some of them may seem more serious than others, but they are all serious. The questions are looking for different things and you need to realize that there are no right and no wrong answers. There are no tricks built into the format: the point here is to study how people think when solving architectural problems. Some of the questions may be answered quickly while others may take a bit longer. There is no rush. If you look at a question and you do not have an answer, it is acceptable to say so. Similarly, if I present you with alternate answers to a question you may decide that it does not matter which alternative is selected. It is acceptable to say that you do not feel that it matters which option is selected. You may draw if you like: I have tracing paper you can use as well as a variety of pens. This session is very free form. The only thing that I request that you do is to think out loud. Rather than internalizing your thought process I want you to verbalize everything that you are thinking as you work through these problems. I will start to pry if I recognize that you are thinking without verbalizing.

What we are going to do is very simple. I am going to show you a number of plan types and ask you a few questions about them.

GW: (Reference Footprint Type A Below)

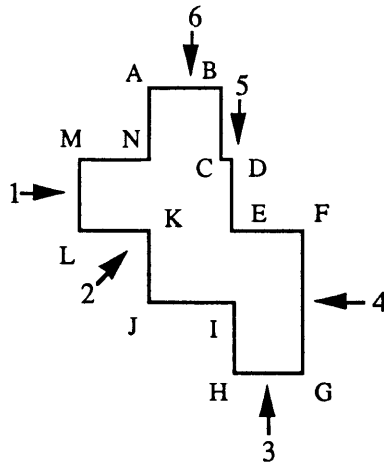

Footprint Type A

This is Footprint Type A. These arrows (1 through 6) represent places that you could possibly enter into the building. The building is of no particular type.

LM: Nobody lives there - I mean nothing happens there?

GW: Something happens there, but I am not saying what it should be: I am not telling you anything about it. What I want you to do is to tell me which entrance into the building is the best.

LM: Well, part of it depends on like how you're approaching the building, what the building is, does it have private areas in the front, or public areas in the front - it doesn't matter?

GW: It may matter, but in this case we don't know that.

LM: OK well, number two is the worst. Two is out - Five is out.

GW: Why?

LM: Well because it's always awkward to have an entrance in the corner of a building because you - unless you have some sort of an additive thing there or its hard to delineate something that looks like an entrance at two.

Five looks like some sort of a service entrance or something like that. Same thing: you're not going to be able to make an entrance look viable there.

Now in terms of the other ones, since the masses are all broken up quite a lot, and since there's no program yet, you might have a better chance of coming up with enough surface...no...I don't know. Well, I'm thinking of...solely in terms of...this, this and this (entrances six, one, and three) are quite similar in their proportions, and six is quite narrow..I don't know...I keep thinking...(she gestures toward, but does not draw on, the footprint.)

GW: What are you gesturing to?

LM: I'm putting in furniture in this thing and thinking about some sort of a lobby for business.

And at the same time, four is different because you have more surface area in terms of the entire mass to come up with some sort of an entry statement. Entry - to articulate the entry. So I am going to pick number four. (as her favorite.)

GW: OK - Where is north on this plan?

LM: Where is north? Well that depends on the climate I would say. We don't know the climate? And the climate doesn't matter at this point?

GW: It may matter, but we don't know it.

LM: OK - So, lets say that north is that way. (North is to the left of the sheet.)

GW: Alright, do you have any feel for where a street might be? A major street?

LM: Well, since I said four was the entrance I think that the street should be along this axis. (Parallel to the right hand side of the sheet.)

GW: How about a parking lot? Is there a parking lot? (Based on her selection of office as the building type.)

LM: Well, OK. There's no parking. I hate parking.

GW: Now we have another one. (Reference Footprint Type B below.)

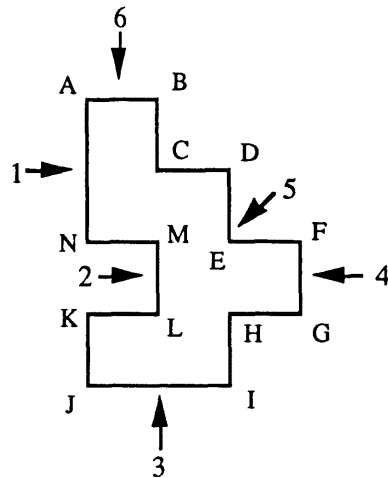

Footprint Type B

These floor plans have certain similarities and certain differences. What I want you to do is to look at this one now and tell me which is your favorite entrance.

LM: Well, I immediately, of course, I'm knocking off number five because it's in the corner. Absolutely not - no way. Two is interesting because it looks like the courtyard of a Peking house. But I wouldn't choose it for most other building types...then I would not choose two - or there also isn't enough area to do a dry climate house. So, I'll knock off two.

Let me turn it (the plan) around. (She turns the sheet in different orientations.)

GW: Why are you turning the plan around?

LM: Because I'm thinking about building approach.

GW: How does turning it around help you do that?

LM: Because I imagine that this is a simple form. I imagine it in three dimensions as a simple, just blocked out form and what it would seem like when you approached this one.

GW: How does it help you?

LM: Well it helps me imagine a real place. I think about...like probably a similar instance of approaching a building that has a similar entrance, or what I might perceive as a similar entrance in terms of the whole form and then I put myself there. Like this one...even though I would not pick that one (number four). By looking at it this way I would not pick four.

So...this might be a neat courtyard (number two). Yeah, I mean just the space there. So for some reason I see this one (Footprint Type B) as a house because it got the...

I guess I'll pick three.

GW: Why?

LM: (She turns sheet upside down so that entry six is on the bottom.) Well, this one (number six) there's not enough...I don't really know how to describe this...well unless...well we don't know a scale for that, but I can't imagine (?).

These are all equal distances (FE, BC, DE). Those are all equal distances, so you're going to have to do something really special here in order to make it stand out. I mean, I 'm thinking of it again in terms of building approach and making an entry. And also it might be sort of hard to...well we don't know a scale so...(she mutters)...I just want to pick that one (entry three).

This one (entry one) might be sort of hard because I've assigned this value as the courtyard, and it might be sort of hard to make this courtyard work...plus this elevation plus this...these three different items.

This one (three) looks like it would be the easiest and still after you enter the building somehow there might be some kind of an opportunity to include this as one of the major public areas in the beginning (the space around entry number two).

GW: So you've picked three. Where is north?

LM: Oh yeah...ok. North, can I take a little while for this?

GW: Sure. Just think out loud.

LM: Is it OK if I assign a meaning to this of some sort?

GW: Sure.

LM: If this is the entry...if three is the entry then this is the more private part of the space, perhaps. (The area around entry number six.) And the more private parts you are probably going to want to have...oh...then again it depends on climate whether you want a lot of east/west exposure or not. Its too hard to control it, so...I will either put north here or here. (Either at four or at one.) And, if its here...then sun goes this way...in the west...so in the morning they're not going to get any kind of exposure (mutters). But its the same...its pretty much the same thing only you get morning and no afternoon. Oh! Well my goodness. I've put a courtyard here (area around entry number two), so this has to be north. (To the right hand side of the sheet at entry four.) Because (the area around) two is a courtyard.

GW: Where is the street?

LM: The street...I think this is skewed a little bit, its going to go like this.

GW: What is skewed?

LM: No, it should go like this. The building is skewed. The street comes around like this. (She gestures)

GW: So the street cuts a diagonal across the lower left hand corner. (Roughly paralleling the angle created by the saw-tooth shape where entry number five is located.) Why?

LM: Why? Because this is pretty interesting form so it would be nice if in your approach you could see...you can see the forms of this building. (She gestures to the saw-tooth form at entry five which runs from B to F.)

Yeah and then we can tuck this courtyard away to make it a little bit more private cause maybe...maybe this courtyard is big enough so that whoever works or lives here can make this a more private space. See they have all this opportunity for exterior space here (gestures toward sawtooth) with all these BC, CD, DE, extra surfaces. I mean all surface area goes here. And...sometimes its interesting to have a perspective view of the entry.

GW: Great. I have another. This is Footprint Type C. (Reference Footprint Type C below.)

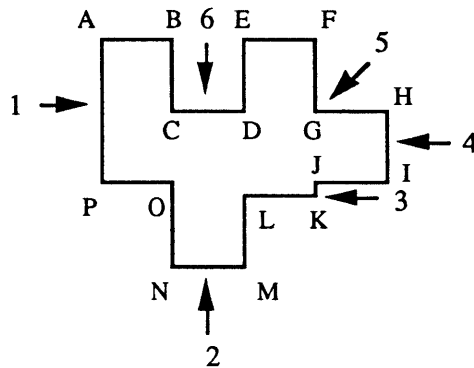

Footprint Type C

I want you to look at this one...I might ask a few different questions on this one...

LM: Alright! Good!

GW: But I'll ask first what's your favorite entrance?

LM: (Mutters) Well...its a toughie.

GW: Why?

LM: Well you know, if these were not perfect squares (the squares defined by ONML at entry two, JIHG at entry four, and DEFG between entries five and six)...these are all almost perfect squares plugged onto the side of this, or this is the extension of this rectangle...whichever (OPAB at entry one), but this reads on...from the exterior of the building as being almost a perfect square...right? And if they were tucked back... if they were not perfect squares, if they were not as deep then they might be more appropriate for entrances. But since they're so deep...and I'm thinking of this roughly as...eighth scale, then this is a little bit too deep for an entrance. (The LM, JI, and ED distances) So all three of these are similar instances because all of...whenever I never pick the short side its because these are almost perfect squares, and its hard to get...to have things to fill up...I don't know how to verbalize that but, to have something to do in there before you get to the main stuff. Its not appropriate for the core of a large building, its...if its a porch then its going to look tacked on, if its just a vestibule of some sort, its going to look tacked on...chances are. So I...usually I've been picking these shorter ones.

This one is hard because...six is hard as an entrance because if you walk into six chances are you're going to want to have openings in this...either the DE side or the BC side and its a little bit...you have this extremely public space here and

two very potentially more private spaces here. (Either side of six is private while moving straight into it is public.) Right, so that makes that a little bit more awkward. Also its a little bit too confining for an entry...you walk in there and its a little bit too private a cove in there for that to be exactly private. Like it might make whoever is walking into six feel uncomfortable to have...

GW: And that is a bad thing?

LM: Yes it is. You don't want anyone to feel uncomfortable. So, well gosh, I'm picking that long side again. (Number one)

GW: Why?

LM: At least I'm consistent. Well, obviously that's from a process of elimination.

GW: Where is the road?

LM: Here we go again. Well this looks almost exactly like the other one doesn't it? But this time (she turns sheet in various orientations and mutters) Can I assign meaning to what kind of road it is?

GW: Sure.

LM: On this one there's a lot of...the main road is out here and were going to have a circular drive come up and drop them off at the porte cochere. (The

main road parallels the left hand side of the sheet, but there is a circular drive that comes in.)

GW: Alright. Where's north?

LM: Although I don't know...maybe if the road came up like this...no.

GW: You thought about bringing an L shaped road in parallel with the bottom and turning up to the right.

LM: Yeah, but then you have problems with your potentially service area being too exposed to the road. (Around five and four) A little bit too exposed to the road.

Oh yeah, where's north? Well again we have got this little courtyard. We don't want this to be a sand..a desert in there (at entry six). We would probably would like to have some sort of green in there (at entry six). So we're going to want to get some sun in there to nurse those plants. So again I think that the sun should be over here...this is north. (North is to the bottom of the sheet at entry two.)

GW: Alright. I have another.

LM: How many more are there?

GW: It doesn't matter. Alright, this is Footprint Type D. Now, I might ask you some different questions about this one this time...

LM: You didn't ask me different questions about the last one.

GW: Let's look at this one a little bit. (Reference Footprint Type D below) I don't know...what's your favorite entrance on this one?

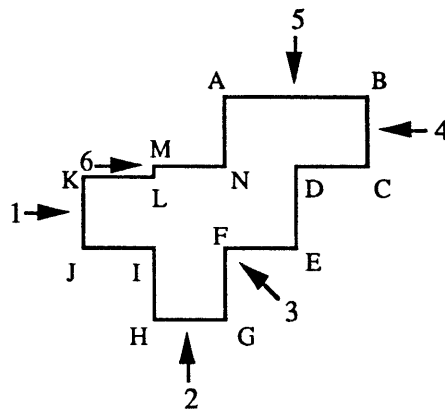

Footprint Type D

LM: Well for the same reasons stated before about the proportions of the additive pieces, I would not pick two or four...no...yeah...two, four, or one. No I don't know...what the heck...(She turns sheet to look at it from a variety of different orientations.)

This seems just the same only I think your just twisting it around aren't you?

GW: The plans are similar.

LM: Are they almost the same? Are you just rotating them? Is that what that means? Can I look at the old ones?

GW: We shouldn't back up too far. (She is not allowed to see the previous plans.)

LM: Number one! Its just the same as number one...I knew you were just rotating it on the page to see if I'll make...to see if my thought process is consistent...I think that's probably what he's doing. The thing is is that I'm bored with naming that long side the entrance. (Laughs)

GW: That's OK. It may be more different than you think.

LM: This is going to be...well, I know that's what I chose before though (number five). But now I'm thinking about it and its going to be like this (?) there and something there. I don't know...I guess we could make it work but its still kind of awkward. Because of its relationship to the rest of the form...you know.

Not four because of the square. Not two because of the square, but for some reason number one doesn't seem as bad. And the reason it doesn't seem as bad I think, although I know I rejected another one that looks like this...I don't know...it doesn't seem as bad.. is because of this extra form here (LMN). Right, the LMN makes it not seem as awkward. Still, its kinda skinny space for an entry. (number one) I don't know. It's between number one and my old standard number five. Long side. Number four...I don't like number four as an

entrance because its skinny, because of the squareness. Number three of course is out. Number six is out. Unless its a prison. And, what the heck..I'm bored with the long side as being the entrance. I think Lora you should choose number one.

GW: Where's the street?

LM: The street on this one (turns sheet in various ways) is...I think...the reason I keep choosing the street even...its not just because the street is usually in front of a building. I mean I think there's a reason for that. I like it when buildings are polite.

GW: Meaning?

LM: Meaning that there is normally that there's a little bit more of a formality about how a building is in relationship to its neighbors, and it has some sort of gesture that says this is where...this the formal way to enter this house, and I'm sort of putting on my best cloths as a member of this community. And usually what better place to say that but where people will hear you. (Laughs)

GW: So this all adds up to?

LM: But I think the street is quite simply along the left hand side of the page. (Parallel to the left hand side of the sheet along entry one.)

GW: Where's north?

LM: Well I just made this a house you see...although this looks like a Frank Lloyd Wright house doesn't it? Well if this were a house...if it were a house, then I would not make it so that north was...to the bottom of the sheet (at entry two) because that would mean that you'd only get morning sun in the front of the building which...and to the front of the building, and chances are that's in this public part of the building, and people might...I mean whoever lives there would not be in the most public part of the building in the morning. Like they're either going to want morning sun in their bedrooms or in the kitchen or near a dining room or something like that..some place where they can take advantage of the morning sun. So other than the fact that it is not at the bottom of the page... If north is here (at the top) then the sun rises as in east..oh its back here. Its going to show in right in there, and we're going to have evening sun there. And you're this whole long area...with absolutely no light during the day.

GW: What area is that?

LM: From K to N and A to B...no light. Just only diffuse light so, north is here, (the right hand side of the sheet) the sun rises here, comes around and goes here...but in the morning I mean you get this and in the afternoon you will get this. So that's the best place for north...on the right side. Because you're more likely...you have more controllable sun all day long.

GW: OK. So you made a comment earlier which I want to follow a little bit. If you were going to say any one of these entrances was a jailor's entrance...

LM: Six.

GW: Why?

LM: Well because, its the smallest entry. It has this...it seems like a service entrance...it looks like its just about wide enough for a door. We don't have a scale for this, but personally its wide enough for a door. It doesn't have much of an entry statement and why should you have a entry statement to the jail? I mean you shouldn't really celebrate...I mean you don't necessarily have to celebrate the entrance to a jail.

GW: That's fine. In looking at this I didn't give you a building type for it, but what have you decided this is?

LM: On this particular one, well I like houses. Houses are fun because its easy to come up with a program for it...its quite small and its very familiar. So I assigned it a house program, but you can give me another program if you want.

GW: So entrance number one is your entrance for this house. What is the dimension from K to J at entry one? From point K to point J...what dimension is that?

LM: Oh you know, you did it on this one...right when I picked my new entry you make me pick a dimension for this.

GW: What are you thinking?

LM: I'm thinking about what goes in an entrance to a house and like coat closets and maybe half baths and...and you don't want it to be too big because you won't have anything to put there. Are these definitely walls? (Points to a line of the footprint.)

GW: Yes. They're walls...you can do anything with them, but they are given walls.

LM: But you can't add walls outside...you can only add walls inside. OK, the dimension is sixteen feet.

GW: We will come back to that. What I want to do now is tell you that this building type is located in an inner city area...a metropolitan area and is located in the inner city...the footprint, and its an electronics store. They sell stereo equipment, TVs, and so forth. Does that effect the way that you located the entrance?

LM: (Laughs) Yes! Definitely.

GW: What entrance is your favorite?

LM: OK...its an electronics store in an inner city. Does it have to have a parking lot?

GW: We don't know.

LM: Don't know yet. An electronics store. Well chances are if they're going to have any windows at all they're going to pretty darn small.

GW: Why?

LM: Well for crime reasons...for security reasons. So...when you say inner city is there some sort of connotation of inner city like a particular kind of inner city or like Boston?

GW: No, just a built-up area...no ghettos.

LM: (Laughs) If it were Harlem maybe this was the entrance...number six.

OK, Definitely...no matter what three is usually a lousy choice if you have other choices. Forget three...so three and six are out.

Do I get to...No I don't know...Will it matter...Does it matter if I pick a dimension. Sixteen feet is now the dimension...right?

GW: That's out. We're done with that.

LM: Two's out because of the proportion of IHGF...its too awkward to get people in there and...unless you have...the only good thing about two, that would be neat about two, is the fact that you could have a vestibule...oh but no, you don't want to do that because then that means that if its in the city then the street's going to have to be there. OK, well...then what the heck are you going to do

with that one? Can you put another building there or like another..are other buildings potentially sitting in with this?

GW: We don't know.

LM: You don't know. I mean is it OK to make assumptions about that, like putting buildings in...

GW: Sure, assume away.

LM: Ok well, I would say that five is the best entrance on this one because you get the most store frontage area...you have the potential for store front plus they can sell this little...well either...the street is here...you're going to ask me that. Along the top of the sheet.

GW: Well, I wasn't, but since you said.

LM: Well there's the street, along the top of the sheet. You have your entrance there, you have the most area for store front, and just enough for some sort of a reception or check out area and then all this sales area for the rest of this form. Plus you either have the opportunity to have some sort of park or different layer..urban layer system like trees, benches, that sort of stuff (in the area outside of ANK). Or you could potentially build-up in there too to make more of a street front line along in there.

GW: Build-up meaning?

LM: New building...another building in the ANK area.

GW: Alright. What do you suppose the dimension of AB is?

LM: OK! I knew this was happening because now I have to since I made the assumption that perhaps you can add another building in there then you have to make it worth your while to add a building in there. Cause street front property is prime stuff. Exposure. So this dimension is roughly half of this dimension. (AN is half of AB) And we don't want AN to be any less than twenty feet by forty feet...God that's huge.. Well what the heck..we don't have a program or a budget here, so AN is twenty feet and AB is thirty feet.

GW: Alright. Now looking at this now I want to tell you that we're changing it again. We are going to say that it is located in a quite suburban area in Massachusetts and that its now a branch library. Does that effect your entrance selection?

LM: It definitely will effect my entrance selection, although I may pick the same entrance again, I don't know.

Well, if its in a suburban area and its a library then you definitely want a library to be friendly. So everybody will want to come in. So your going to really want to play up the entrance to a library and at the same time make it so the rest of it gets the most light as possible...even though I guess in libraries there are areas that need to be away from the sun too, but usually that's not a problem. This is a little branch library you say?

GW: Yes. Think out loud.

LM: Well this way the (number) two entrance for this one has the potential of being kind of a cutesy little formal entrance of some sort. And libraries a lot of times can have pretty formal faces to the street...little civic buildings (?) or something.

One is out - too awkward. Six is out - too awkward. Five would work, but maybe not. This is too hard (number four)...hard to make it look. In a library branch, even though its just a little branch library and its small and its in suburban Massachusetts...this...even if it were a really large scale its too awkward...you definitely want...the entry is going to be very important to a branch library, and its going to want to be slightly more formal than a house entry or a retail entry or something like that. So this is going to be too hard to make that work...too hard to make four polite. So, and three is of course always out.

I think this one, lets pick number two.

GW: OK. Because it satisfies this criteria you've been working with?

LM: Yes.

GW: Where's the street?

LM: The street is somewhere along the bottom side of the page (toward entry two). It could be turned...I mean it depends on if the street is curved or not. If its a straight street then its along the bottom side of the page. Pretty boring.

GW: OK. What's the dimension of HG (at entry two)? What are you thinking?

LM: I don't know..I'm picturing how big this...how big is this? Twenty feet? Twenty five feet? I'm thinking that it might be kinda of nice if we have our check out area either here or...in Massachusetts your going to want to have a coat room because you don't want people dragging in snow and stuff and so were going to have to have an entrance here. I guess we would probably want (mutters) although...I'm trying to think about where the circulation desk would be, and I guess they usually need another space in the back of the library...I've never done a library so I don't know, but they probably need another little space for cataloging and wherever the librarians work. And I don't think its fair to stick the librarians in the middle where artificial light is because they're the people who have to be there all day long. I think they deserve natural light too. So I think the librarians will be here (at LMN). I was thinking that maybe it might even be possible to put circulation desk in here and then and if this were large enough (she gestures to IHGF)...since I'm picking a scale. But it would have to be awfully large in order to get things like coat rooms and book shelves...you know book cubby hole things for people or something to get all the criteria for the entry area of the building and circulation desk it might be a little bit cramped unless you made it absolutely humongous and then we're out of our branch library scale. So were going to put the circulation desk there.

Maybe we can have a coat room...if that's twenty feet...twenty, forty, sixty (she adds dimensions across the face of the building)...I don't really know how much room for books. Sixty feet though, about branch library size isn't it? Maybe not...maybe...twenty five, thirty, ninety (she adds dimensions across the face of the building). If it gets much bigger than thirty what the heck are you going to do with it all?

Thirty Feet.

GW: HG is thirty feet. OK. Looking at this do you see any geometric shapes in the plan?

LM: You mean like squares, rectangles and stuff? What do you mean?

GW: Do you see any geometric shapes? Are there any geometries that you see when you look at this plan?

LM: In the relationship of all these pieces? Like do I see a rectangle continuing through in here, and squares plugged on or maybe this a rectangle? Yes, I see geometries.

GW: What do you see?

LM: Well I see lots of different things. This lines up. MN and DC line up.

GW: I'm talking about a bigger...for example, some people look at this and see a W shape.

LM: Right. I did not see that W shape.

GW: Do any of them hit you. It doesn't have to be that, I mean it could be anything. Some people also see little pods attached to a central....

LM: OK. Well there could be lots of different things. The things...the things I see are...

GW: Don't think about it. Have you seen one thus far?

LM: Yes. Definitely. The thing that really hits me, especially on some of those other ones are...because this is almost a perfect square, then that square is more easily identifiable as a square and so this...as a separate entity...so its easier for that to be a plug-on piece. That's why I've had trouble calling that the front of the building because it looks like its a tack-on piece because its a perfect square and it kind of takes on its own identity. So...but at the same time...like these two pieces...this one is (DCB) harder to see as a plug-on piece even though I know that its the same proportion as KJI and IHG because its at the end of this other piece...from either side...unless you look at four...side four as an entrance you still have that plug-on feeling, but from this side it makes a rectangle there, so four is not the same. So in this one its very...I see this as this lightning bolt sort of thing with two plug-on squares.

GW: So what you're seeing is part of a W with two squares.

LM: Or I see it as this L shape with one square plug-on and one rectangle plug-on. (DMHGFE with square LKJI plug-on and rectangle NABC plug-on)

I see it as just this rectangle....DMIE with two squares and a rectangle...did we already do that one...no...or you can break it down to just this rectangle, this rectangle, and these two squares as being plugged-on.

Also, I also think of this too, especially if you turn it a different way, I think of this KJED as...even though its not a whole shape, I think of that as a core and these two (IHGF and NCBA) being plug-on pieces.

GW: OK, that's fine.

LM: Especially if you think of that like as a,...like a linear piece. (She looks at the drawing with the left hand side at the bottom of the orientation.) This looks like the Robie House, sort of. (She turns sheet upside down and gestures to its likeness to the Robie House.) So I would see this (NABCDEF) as being almost a main piece to this one (FGHIJKL)...just these two... and this as the plug-on. Even though these are two separate pieces but when you look at it from this way - upside down - these two pieces can be like two main pieces with just this one skinny rectangle - LMN - plugged-in, and this (LMN) as being the auxiliary piece or the tertiary form.

GW: OK. Lets just do a couple of more pieces. Look at this (Footprint Type C) real fast and tell me if you do or do not see a geometric figure there.

LM: The first thing I see is a U with two plug-on pieces.

GW: OK, do you see a geometric figure on Footprint Type B?

LM: This one seems more complex. I see this one more as an L and a lightning bolt, or a U with two plug-on pieces.

GW: The L being ANED and the lightning bolt being ANLH?

LM: No, I don't see that. I see that (the lightning bolt) more on the sides than I do in a volume. I see the lightning bolt thing as more in the face, but the volume...the lightning bolt...this one (MLKJIHGF), and this (ANEDCB) is the L. I bisect it along NF.

GW: In looking at this one (Footprint Type A) do you see any geometric forms?

LM: OK, this almost the same as the other one. This one is easier to see the lightning bolt.(MLKJIHGFED). Yeah and the only add-on piece to the lightning bolt here is (she gestures to ABCN).

GW: So you're calling the W shape a lightning bolt?

LM: Yeah. W shape - W shape.

GW: Alright, last question. I want you to think about the idea of a branch library on a suburban site, and to very briefly tell me, as if this was a dream...if you were doing a branch library for yourself, and this was going to be your branch library - built exactly how you wanted, then this would be the ideal branch library. What would you say are just four of five features of the ideal branch library? What is characteristic of it?

LM: Very light with windows...lots of natural light.

Some sort of courtyard or acceptable outdoor space to read.

Something that was, well, its hard to monitor...I concentrate best in libraries that are not too quiet. I like a lot of stuff going on, but not usually lots of kid stuff going on. So the children's area a little bit more secluded for noise, but circulation is also in there and happening. You know, the circulation is more integrated in with all the rest of the area.

No plastic furniture (laughs).

Doesn't need to have pods...not necessarily plastic cubical pods, but to have a row of pods where you can completely go and seclude yourself away from other people, but still have the opportunity to not be that way too. Like the Exeter library...those are pretty nice - those chairs - but, cause they have a window and a desk to work at. The great thing about that library too is that you can see outside the window...not just when you sit down, but they have seating that faces the window and they have very low sills in the Exeter library which I

really love because you can sit down and it doesn't limit your view from waist high or from just below eye level up to the sky...your allowed to see what happens below too. That's nice.

What else? Refreshments...you're allowed to drink and eat in this library, but its the ideal library so everyone still takes care of the books but they can eat and drink in there...but its everybody's branch library so this is the ideal situation...so everyone is careful with the books too.

GW: OK, that's enough pieces...thank you.

(Note that Lora did not draw during the process even though she had tracing paper and ample drawing materials.)

Biographical Information on Lora

Lora works in an architectural firm in Boston Massachusetts. She has a four year degree in architecture from a college in Florida, and has over three years of experience.

Lora is twenty seven years old and was raised near Tampa Florida in Dade City, where she lived until she was eighteen years old. At that time she moved to Gainsville Florida to attend college. After graduation she moved to Boston Massachusetts.

She has traveled in Europe and eastern United States.

Bibliography

"Iowa's Fields," *Progressive Architecture*, April, 1973.

Alexander, Christopher. *Notes on the Synthesis of Form*, Harvard University Press, 1966.

Arnheim, Rudolf. *Art and Visual Perception*, University of California Press, 1954.

Broadbent, Geoffrey. *Design In Architecture*, John Wiley and Sons, 1973.

Carey, Susan. *Conceptual Changes in Childhood*, MIT Press, 1987.

Dewey, John. *Reconstruction in Philosophy*, Beacon Press, 1948.

Goldschmidt, Gabriela. "On Architectural Sketching," draft.

Habraken, John. *The Appearance of the Form*, Awater Press, 1985.

Habraken, John. "The Control of Complexity," *Places*, 4(2). 1987.

Le Corbusier. *The Chapel at Ronchamp*, Frederick A. Praeger, 1957.

Moneo, Rafael. "On Typology," *Oppositions*, (#13). 1978.

Panofsky, Erwin. *Meaning in the Visual Arts*, University of Chicago Press, 1955.

Porter, William L. "Notes on the Inner Logic of Designing: Two Thought Experiments," *Design Studies*, July, 1988.

Rowe, Peter. *Design Thinking*, MIT Press, 1987.

Schön, Don. *Educating the Reflective Practitioner*, Jossey-Bass, 1987.

Schön, Don. "Designing: Rules, Types, and Worlds," *Design Studies*, July, 1988.

Schön, Don, and Glenn Wiggins. "Kinds of Seeing and Their Functions in Designing," forthcoming.

Simmonds, Roger. *Learning to Learn and Design*, MIT PhD, 1978.

Vickers, Geoffrey, Sir. *The Art of Judgment*, Basic Books, 1965.

Vickers, Geoffrey, Sir. *Human Systems Are Different*, Harper and Row, 1983.