

FEASIBILITY OF SEMI-CONTINUOUS SOLAR DISINFECTION
SYSTEM FOR DEVELOPING COUNTRIES AT A HOUSEHOLD LEVEL

by

Déborah Xanat Flores Cervantes
B.S. Chemical Engineering (2002)
Universidad de las Américas-Puebla

Submitted to the Department of Civil and Environmental Engineering in partial
fulfillment of the requirements for the degree of

MASTER OF ENGINEERING
IN CIVIL AND ENVIRONMENTAL ENGINEERING
AT THE
MASSACHUSETTS INSTITUTE OF TECHNOLOGY

June 2003

© 2003 Déborah Xanat Flores Cervantes
All rights reserved

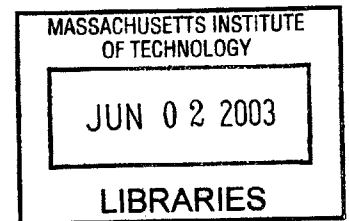

The author hereby grants to M.I.T. permission to reproduce and distribute publicly paper
and electronic copies of this thesis document in whole and in part

Signature of the Author _____
Department of Civil and Environmental Engineering May 9th, 2003

Certified by _____
Susan Murcott
Thesis Supervisor
Lecturer, Department of Civil and Environmental Engineering

Certified by _____
Bettina Voelker
Thesis Supervisor
Associate Professor, Department of Civil and Environmental Engineering

Accepted by _____
Oral Buyukozturk
Professor of Civil and Environmental Engineering
Chairman Departmental Committee on Graduate Studies

BARKER

FEASIBILITY OF SEMI-CONTINUOUS SOLAR DISINFECTION SYSTEM FOR DEVELOPING COUNTRIES AT A HOUSEHOLD LEVEL

by

Deborah Xanat Flores Cervantes

Submitted to the Department of Civil and Environmental Engineering on May, 2003 in partial fulfillment of the requirements for the degree of Master of Engineering in Civil and Environmental Engineering.

ABSTRACT

A study to assess the feasibility of a novel solar water disinfection system developed by the author, Semi-Continuous Solar Disinfection (SC-SODIS), was conducted. Three aspects of SC-SODIS feasibility were considered: technical, social and economic feasibility. This study focused on developing countries and specifically, Nepal. To address the technical feasibility, field data included measuring the performance of the prototype system under climatologic conditions found in Lumbini, Nepal during the month of January 2003. The social and economic feasibilities were determined from preliminary feedback from local people and calculation of construction costs from locally available materials respectively.

Results suggest SC-SODIS is a feasible technology for developing countries and specifically Lumbini, Nepal. SC-SODIS can be considered a sustainable technology as it is technically simple, effective at microbial inactivation as measured by the *E.coli* indicator organism, can be made from locally available materials and is economical. Preliminary feedback from locals show SC-SODIS is socio-culturally acceptable. Limited time did not allow study of the operation and maintenance problems that the system might present over the long term.

Thesis Supervisor: Susan Murcott
Title: Lecturer, Department of Civil and Environmental Engineering
Thesis Supervisor: Bettina Voelker
Title: Associate Professor, Civil and Environmental Engineering

**TO MY MOM,
FOR TEACHING ME TO THANK FOR EVERY DAY OF MY LIFE**

**TO MY DAD ,
FOR TEACHING ME TO DREAM AND FLY**

**TO MY BROTHER AND SISTER
FOR SHARING WITH ME THE LOVE OF LIFE**

**TO MY GRANDPARENTS
FOR ALL THEIR LOVE**

**TO MAXI
FOR BEING A VERY IMPORTANT PART OF MY LIFE**

ACKNOWLEDGMENTS

To God,
for every day I live.

To my parents,
for all their support and advise in every step I take.

To my siblings,
for being there whenever I need them.

To Susan Murcott,
for giving me the wings to fulfill my dreams.

To Tina Voelker,
for all her time, patience, sharing of knowledge,
and help in keeping my feet on the ground.

To Melanie Pincus,
For being such a great companion in Lumbini.

To all the people at IBS, and specially Bhikkhu Maitri,
for being such great hosts, making me feel at home,
reminding me of the joy and love of simplicity,
and helping me build the SC-SODIS.

To all the Nepal Team,
for the great moments in Nepal,
specially for the unforgettable moments in the Annapurna Range.

To all the M. Engers,
for the great past nine months.

To all the people at the Department of Civil and Environmental Engineering,
for their help and support over the last nine months,
specially to Pat Dixon, Cynthia Stewart, Patricia Maguire, James Riefstahl.

To Dr. Eric Adams,
for his help in this thesis to characterize the flow in the SC-SODIS,
and special thanks for making the M. Eng. Program possible.

To CONACYT (Comisión Nacional de Ciencia y Tecnología)
for giving me the means to fulfill my studies,
and to COMEUX (Comisión Mexico-Estados Unidos)
for letting me be part of the Fulbright experience.

TABLE OF CONTENTS

I. INTRODUCTION.....	11
1.1 Water quality situation in the world.....	12
1.2 Water Quality and Quantity Situation in South-Asia.....	14
1.3 Outline of Nepal: Geographical, Historical, Social, Political and Economical Situation.....	15
1.4 Purpose of Study.....	18
1.5 Hypothesis.....	18

SECTION I: OVERVIEW OF SOLAR DISINFECTION SYSTEMS

II. POINT-OF-USE AND HOUSEHOLD LEVEL TECHNOLOGIES.....	20
2.1 New Trends in Household Level Technologies.....	22
2.1.1 <i>Sedimentation</i>	23
2.1.2 <i>Boiling or Pasteurization</i>	23
2.1.3 <i>Water Filtration</i>	24
2.1.4 <i>Chlorination</i>	25
2.1.5 <i>UV Radiation</i>	25
2.1.6 <i>Solar Disinfection</i>	25
2.2 Solar Disinfection.....	26
2.2.1 <i>Solar Radiation</i>	26
2.2.2 <i>Disinfection Effects of Solar Radiation</i>	28
2.2.3 <i>How does solar disinfection work?</i>	29
2.2.4 <i>Effect with Oxygen</i>	30
2.2.5 <i>Synergistic Effect with temperature</i>	31
2.2.6 <i>Turbidity</i>	32
2.2.7 <i>Efficiency of inactivation</i>	33
2.2.8 <i>Microbial indicators</i>	34
III. PREVIOUS SOLAR DISINFECTION STUDIES AND APPLICATIONS.....	36
3.1 American University of Beirut, Lebanon.....	37
3.2 Integrated Rural Energy System Association (INRESA).....	40
3.3 EAWAG/SANDEC.....	40
3.4 Previous work by organizations in Nepal.....	43
3.4.1 <i>International Buddhist Society- Global Resources Institute</i>	43
3.4.2 <i>ENPHO-EAWAG/SANDEC</i>	44
3.5 MIT M. Eng. Students in Nepal and Haiti.....	45
3.5.1 <i>Amer Khayyat</i>	45
3.5.2 <i>Megan Smith</i>	46
3.5.3 <i>Peter Oates</i>	48
3.5.4 <i>Julie Parsons</i>	49
IV. SOLAR DISINFECTION SYSTEMS.....	50

4.1 SODIS	51
4.1.1 Principle of SODIS.....	51
4.1.2 Important Variables	53
4.1.3 Advantages and Disadvantages	54
4.2 Continuous Solar Disinfection System	54
4.2.1 Principle of Continuous Solar Disinfection System	55
4.2.1 Advantages and Disadvantages	55
4.3 Semi-Continuous SODIS (SCSODIS)	56
4.3.1 Principle of SCSODIS	57
4.3.2 Advantages and Disadvantages of SCSODIS.....	58

SECTION II SEMI-CONTINUOUS SOLAR DISINFECTION SYSTEM

V. DESIGN CONSIDERATIONS.....	61
5.1 Fluid Mechanics	61
5.2 Construction Materials	64
5.2.1 PET Bottles.....	64
5.2.2 Glue	65
5.2.3 Pipes	66
5.3 Operation and Maintenance Procedures.....	66
5.4 Water Source Holding Tank.....	66
5.5 Aeration	67
VI. METHODOLOGY.....	68
6.1 Bacteriological Tests	69
6.3 Manipulation of samples and bacteriological tests.....	73
6.4 Water Quality Well Measurements	75
6.5 Solar radiation measurements	76
6.6 SC-SODIS monitoring	77
VII. RESULTS AND ANALYSIS.....	78
7.1 Technical feasibility	79
7.1.1 Tube well collection data	79
7.1.2 Solar radiation	81
7.1.3 SC-SODIS System Data Collection.....	84
7.1.4 Liters of purified water produced daily.....	86
7.2 Social Feasibility	87
7.2.1 SC-SODIS social feasibility facts.....	87
7.2.2 General findings	88
7.3 Economical Feasibility	89
VIII. CONCLUSIONS	91
IX. RECOMMENDATIONS AND FURTHER STUDIES.....	94
9.1 Bacteriological tests	94
9.2 SC-SODIS system follow-up	94

9.3 Socio-Educational Issues.....	95
9.4 Final Recommendations.....	96
VI. REFERENCES.....	98
APPENDIX A Daily and Hourly Taken Measurements.....	102
APPENDIX B Well Measurements Lumbini, Nepal (January 2003).....	113
APPENDIX C ENPHO Results	117
APPENDIX D Pictures SC-SODIS.....	124
APPENDIX E Tracer Test Measurements and Analysis	128
APPENDIX F Construction Manual.....	136
APPENDIX G Data From IBS Clinic, Lumbini, Nepal.....	141

TABLE OF FIGURES

Figure 1.1 Distribution of Global Population not Served with Improved Water Supply	12
Figure 1.2 Distribution of Global Population not Served with Improved Sanitation	12
Figure 1.3 Geographic Map of nepal.....	15
Figure 2.1 Worldwide Distribution of Solar Radiation into Belts Indicating Feasibility of Solar Applications.....	28
Figure 2.2 Radiation Bands and Wave Length Ranges.....	29
Figure 2.3 Inactivation of <i>E. coli</i> Under Aerobic and Anaerobic Conditions.....	30
Figure 2.4 Synergetic Effect of UV-Radiation and Temperature on Fecal Coliforms in Raw Water.....	31
Figure 2.5 Inactivation of fecal Coliforms in a PET-bottle on a Black Underground	32
Figure 2.6 Reduction of UV-A Radiation as a Function of Water Depth and Turbidity	33
Figure 3.1 Germicidal Effect of Solar Radiation on Bacteria Contaminating Water Held in Blue Glass Containers.....	38
Figure 3.2 Layout of Type I Solar Reactor System	39
Figure 3.3 SODIS System Scheme.....	42
Figure 3.4 SOPAS System Scheme.....	42
Figure 3.5 Average Insolation Simulated per Calendar Month Ten-Year Average in Indian Terai (south of Lumbini).....	47
Figure 3.6 Maximum, Minimum and Average Insolation Calculated for the Five-Midday Hours in Comparison to Maximum Average for the Full Day.....	47
Figure 4.1 Turbidity Test for 30 (threshold) and 20 NTUs.....	51
Figure 4.2 SODIS. Four Basic Steps.....	53
Figure 4.3 Solar Continuous Disinfection System.....	55
Figure 4.4 Bottles Arrangement for SC-SODIS.....	57
Figure 4.5 Semi-Continuous SODIS.....	58
Figure 5.1 Measures of Spatial Relationship Between Pipes and PET Bottles.....	63
Figure 5.2 a) Inclination Angle and b) Coordinate Position of SC-SODIS.....	63
Figure 5.3 Bubble Formation in SC-SODIS.....	67
Figure 6.1 P/A Test Equipment and Supplies for H ₂ S Producing Bacteria.....	70
Figure 6.2 Membrane Filtration Test Equipment and Supplies for Total Coliforms and <i>E. Coli</i> /Fecal Coliforms.....	73
Figure 6.3 Millipore Portable Single Chamber Field Incubator XX63 1K0 00.....	74
Figure 6.4 HACH™ Pocket Turbiditymeter and Cuvette.....	76
Figure 7.1 MF Results from 21 Wells in Lumbini During January 2003.....	80
Figure 7.2 Hourly Incidental Solar Radiation Received in Lumbini, January 2003	81
Figure 7.3 Average Incident Solar Radiation Received in Lumbini , January 2003	82
Figure 7.4 Integrated Solar radiation in Lumbini During January 2003...	83
Figure 7.5 SC-SODIS % <i>E. coli</i> Removal at Different Flowrates in Lumbini During January 2003.....	84
Figure 7.6 SC-SODIS % <i>E.coli</i> Removal with Different Equivalent Days of	85

Exposure.....	
Figure 7.7 Total Coliforms in SC-SODIS.....	86

TABLES

Table 1.1 World Population by region.....	11
Table 2.1 Physical Methods for Water Treatment at Household Level.....	23
Table 2.2 Chemical or Physical-Chemical Methods for Water Treatment at Household Level.....	23
Table 2.3 Thermal Resistance of Microorganisms.....	24
Table 2.4 Spectral Bands of Incoming Solar Energy and Atmospheric Effect.....	27
Table 2.5 Solar Disinfection Efficiency During Demonstrative Workshops.....	33
Table 2.6 Solar Disinfection Removal Efficiency at User Level.....	34
Table 2.7 Results from IMTA for Inactivation of Microorganisms Under Normal Mexican Climate Conditions.....	34
Table 4.1 Advantages and Disadvantages of PET and Glass Bottles.....	52
Table 4.2 Important SODIS Variable.....	54
Table 4.3 Advantages and Disadvantages for SODIS as a Household Disinfection System.....	54
Table 4.4 Advantages and Disadvantages of Continuous Solar Disinfection System	56
Table 4.5 Advantages and Disadvantages of SC-SODIS.....	58
Table 5.1 Results from Bottle Survey in the U.S.	65
Table 5.2 Results from Glue Sampling in the U.S. (October-December 2002).....	65
Table 6.1 Confidence Limits for MF under 20CFU/100ml.....	72
Table 7.1 Results from Well Monitoring in Lumbini During January 2003.....	79
Table 7.2 Correlations Between H ₂ S and MF Tests based on Results from Well Monitoring in Lumbini During January 2003.....	79
Table 7.3 Correlation Between IDRC H ₂ S P/A Tests and Fecal Coliform MF Tests (Lumbini, Nepal, January 2002).....	80
Table 7.4 Integrated Solar Radiation and Observations of Weather in Lumbini During January 2003.....	83
Table 7.5 Results form Lumbini Well Surveys (1999-2002).....	88
Table 7.6 Prices of Construction Materials for SC-SODIS in Nepal During January 2003.....	89

I. INTRODUCTION

I. INTRODUCTION.

1.1 Water quality situation in the world.

Water is essential for life, and both quantity and quality are important. However nowadays we face the threat that one-sixth of the world's population, 1.1 billions people (WHO, 2002), lack access to improved¹ water supply, and two-fifths, 2.4 billion people, lack access to improved sanitation² (Figure 1.1). In many developing countries this problem has led to a high risk of water-borne diseases such as diarrhea, cholera, typhoid fever, hepatitis A, amoebic and bacillary dysentery, etc, that in certain cases causes death of millions of people, especially children.

Most of these people live in Asia and Africa, where less than half of Asians have access to improved sanitation, and three-fifths of Africans lack to an improved water supply. These numbers, however, are for urban areas; rural areas are even farther from the goal of universal access to a safe and plentiful supply of drinking water and appropriate sanitation.

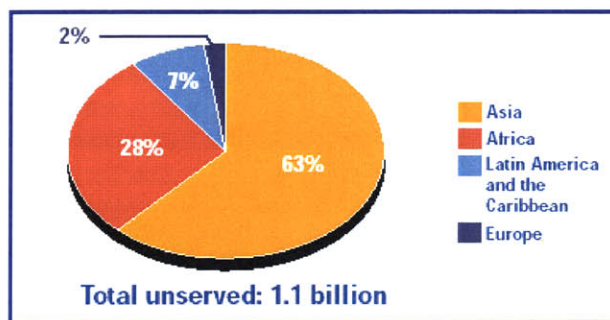

Figure 1.1 Distribution of Global Population not Served with Improved Water Quality Supply. SOURCE: (WHO/UNISEF, 2002)

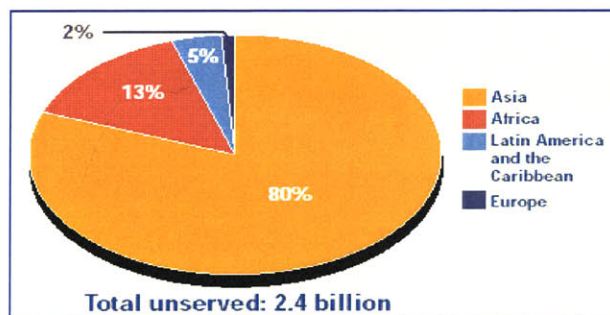

Figure 1.2. Distribution of Global Population not Served with Improved Sanitation. SOURCE: (WHO/UNICEF, 2002)

¹ That includes one of the following: household connection, public standpipe, borehole, protected dug well, protected spring (WHO, 2000)

² That includes one of the following: connection to a public sewer, connection to septic system, pour-flush latrine, simple pit latrine (WHO, 2000)

	Africa	Asia	LA & C	Oceania	Europe	N. Amer.	Global
1990	615	3 180	441	26	722	282	5 266
2000	784	3 683	519	30	729	310	6 055
% Increase	27.5	15.8	17.7	15.4	1.0	9.9	15.0

Table 1.1 World Population by Region (in Millions)
Source (WHO/UNICEF, 2002)

In the past, governments in developing countries have tried to improve the water supply systems, especially in urban areas where the largest numbers of people are congregated; however, in many cases these plans have failed, leaving the quality of water consumed the people's own responsibility. This devolution of responsibility to local citizens is even more true in rural areas.

As for the cause of governmental failures, these may be due to personnel inefficiency all the way to corruption, and in some cases, malfunction of the system is out of the reach of government agencies. In the best cases, the national governments regulate the water issues of the country, but in others, these matters are regulated by regional, state or local government agencies, or even private agencies. In the first case federal governments usually regulate water supply, wastewater disposal and management, groundwater withdrawals, etc., but in the second, unable to have direct control, governments have failed to correct market distortions, market price regulations, subsidy to resource users and polluters, inappropriate tax incentives and credits, overregulation or underregulation, bureaucratic obstacles and inertia, and conflicting regulatory regimes. In addition, the lack of technology, capital investment (the majority of developing country citizens earn less than U.S.\$2.00/day), and the scarcity of resources have added to the governments' failures.

Studies have shown that interventions in hygiene, sanitation and water supply are critical factors controlling the disease burden and contributing to human well-being. For example, according to UNICEF (E-Conference, 2002) the simple act of washing hands with soap and water can reduce diarrheal disease transmission by one third. With the awareness gained from such studies, universal access to safe water and sanitation has been promoted. In 1980 the UN General assembly proclaimed the 1980-90 as the International Drinking Water Supply and Sanitation Decade, urging governments to provide all their citizens with water and adequate sanitation by the end of 1990 (Munasinghe, 1990). Today, more than a decade past the target, we see that the goal has only been reached by a small number of developed countries. The 2000 "Millenium Declaration" established an ambitious but still incomplete goal of halving the proportion of people without access to safe water by 2015 (Sobsey, 2002).

1.2 Water Quality and Quantity Situation in South-Asia.

Throughout South –Asia, including our study area, Nepal, a growing population faces problems of water pollution and water scarcity. Even though these are well-known problems in the region, they are poorly documented, and there has not been enough done to alleviate these problems (Moench, 1999).

In this region there are many cities, towns and villages that lack sewage facilities as well as treated water supply, and even in the cases where there is sewage treatment, it's treatment is inadequate, potentially becoming a source of water pollution. Other point and non-point sources of pollution coming from different industrial and municipal untreated wastes, and runoff, including pesticides and fertilizers from farming activities, have also contributed to the present problem.

On the other hand, groundwater depletion has become a problem due to competition over scarce water supplies. Ambiguity over groundwater property rights usually leads users to compete with one another, where the one that is able to dig the deepest well is the winner in this competition, and often the poor lose out (Moench, 1999).

Another big challenge faced by the region is the annual variability in the annual rainfall. This leads to intense but short duration runoff limiting the set of responses that could be technically feasible if water harvesting systems were constructed to help reduce water scarcity. As an example, farmers in the Terai, the southern region of Nepal, face major water scarcity problems during the dry season periods each year (September to May). However, almost three fourths of the annual rainfall (160-200 cm/year) typically occurs over short time periods during the monsoon season (June-August), leading to frequent flash floods (Moench, 1999).

The gap between the village and the state.

Throughout South Asia, there are mainly two types of organizations in charge of the water management: national/ state or local. Most of the government organizations are centrally controlled either at the national level or at the state level, being part of large governmental bureaucracies and having little relationship with local realities of water management needs. Village level organizations are generally small and localized, dealing with water management needs at a local level and often operating informally. Although these organizations are directly linked to the local problems and realities, they function with little technical expertise (Moench, 1999). In many cases the failure of these organizations is the lack of a middle level organization to link national and local governments, or reduce the polarization.

In many parts of South Asia, including Nepal, day-to-day use of water at local levels follow the traditional rules of allocation and forms of water rights. Historically, water supply depended on the initiative of individuals and local communities to dig wells or divert streams to meet their needs. With population growth, however, this has gone beyond the scale at which communities or individuals can respond, leaving it up to the government to develop supply systems.

1.3 Outline of Nepal: Geographical, Historical, Social, Political and Economical Situation.

The Kingdom of Nepal, more than 1,500 years old and ruled by hereditary monarchs until 1992, is located among the southern slopes of the Himalayan Mountains in South Central Asia. It is bordered by China to the north and surrounded by India to the east, west and south. This country of an estimated area of 145,391 Km² (5,6136 Mi²) and population of 24 million people (Nepali webpage), is divided into three main topographical regions: the Mountains of the main Himalayan Range, the Hills or Kathmandu Valley, and the Terai, which is a narrow flat belt of alluvial land that extends along the southern border with India.



Figure 1.3. Geographical Map of Nepal
SOURCE: National Geographic 2000

Nepal has a climate that ranges from subtropical summers with mild winters in the southern lowlands to an alpine climate with cool summers as well as severe winters in the mountains. Average annual precipitation decreases from 1,778 mm (70 in) in the east to 899 mm (35 in) in the west. Average temperature ranges in Kathmandu are from 2 to 20 degrees Celsius (36 to 73 degrees Fahrenheit) in January to 20 to 29 degrees Celsius (68 to 84 degrees Fahrenheit) in July.

Due to its diversity, the country could be said to be a small representation of a larger regional complex containing the highest mountain chain on earth surrounded by diverse ecological zones. This region is also rich in diverse social systems, ethnic groups, scores of languages and almost all the major religions in the world. The country is home to more than a dozen ethnic groups from three major ethnic divisions: Indo-Nepalese, Tibeto-Nepalese, and indigenous Nepalese. These ethnic groups are primarily

distinguished by language and dress, social organization, occupation, and religious practices. Hinduism is the official religion of Nepal; however, most of the Nepalese practice Shivanism, a synthesis of Hinduism and Buddhism (Sayada, 1991).

Even though education is free and compulsory for five years, illiteracy rates remain extremely high (40% males age 15 and higher; 75% females age 15 and higher), and other social services in the country are scarce. Concerning its international policy, over the last years, it has established bilateral diplomatic relations with countries beyond India and China, and has joined many multilateral and regional organizations.

Since 1980, Nepal's government and society have taken many steps towards a representative democracy, including changing the former *panchayat* (a centrally controlled partyless council system of government). However, replacing Nepal's long tradition of autocracy with a democracy has left scars that still affect the country.

As described earlier, Asia, with some of the poorest countries (e.g. Bangladesh, Nepal) is one of the most needy continents as regards water supply and sanitation. In Nepal, the Gross National Income is \$5.9 billion per year (mainly from agriculture and tourism), and the per capita income is \$250 per year (World Bank, 2001). Of the total population, 81% is said to have access to improved water sources and only 75% of the urban areas have access to sanitation, where 12.2% of the total population is considered urban. This has led to many health problems that are related in one way or another to the high child mortality rate for diarrhea (under 5 years 104.7 per 1,000) and the short life expectancy (58.9 years) (World Bank, 2001). As in many other developing countries, it has been found that some of the most chronic and widespread health problems are due to waterborne diseases. Other factors that have influenced these numbers are the poor nutrition, and the general absence of medical care and other social services, particularly in rural areas. Some of the main environmental issues that Nepal faces are: deforestation due to the overuse of wood for fuel and the lack of alternatives; water contamination, mainly due to human and animal wastes, agricultural runoff, industrial effluents; wildlife conservation; and air pollution in the urban areas, especially from vehicular emissions (Sayada, 1991).

The Government of Nepal (His Majesty's Government of Nepal, HMG/N) alone has not been able to stop or reduce these problems. Due to this, in the past ten years, many Non-Governmental Organizations (NGOs), such as NEWAH (Nepal Water for Health), Environmental and Public Health Organization (ENPHO), Yula Urban Health Project, and bilateral aid agencies such as Finnish Aid (FINNIDA), Danish Aid (DANIDA) and others have established assistance programs for the implementation of education, health and environmental improvements.

The Terai Region

The Terai Region is a flat lowland tropical and subtropical alluvial land that extends along the Nepal-India border, parallel to the Hill Region. It is the northern extension of the Gangetic Plain in India arising from about 300 meters to about 1,000 meters above sea level. The region includes several valleys, like the Surkhet and Dang valleys in Western Nepal, and the Rapti Valley (Chitwan) in Central Nepal.

The word *terai* ("damp" from Persian) suitably describes the region's humid and hot climate. This region was formed and is fed by three major rivers: the Kosi, the

Narayani (India's Gandak River), and the Karnali, and includes dense forests, commonly known as *char kose jhari*.

In terms of both farm and forest lands, the Terai is becoming Nepal's richest economic region. Terai residents enjoy a greater availability of agricultural land than do other Nepalese because of the area's generally flat terrain, drainage and nourishment by several rivers. Additionally, it has the largest commercially exploitable forests. Due to its physical properties, since 1991, the Terai has served as the country's granary and land resettlement frontier, becoming the most desirable internal destination for land-hungry hill peasants. However, due to the growing demands for timber and agricultural land, the forests have become increasingly destroyed, leading to severe deforestation problems.

Lumbini

Lumbini, located near the Indian border in the Terai's middle south region, is the name of Siddhartha Gautam's (Buddha) birthplace. It is located in the Terai region of Nepal, and is the home to the indigenous Tharu people, one of the oldest native groups of the region.

In Lumbini, most of the people live in agrarian communities. Access during the dry season is limited to foot, bike, jeep or tractor, however, during the monsoon season, these communities become practically inaccessible.

The situation in this region is by no means better than the one seen in the rest of the country: water and sanitation are left to the household owners. However, most of these people have very scarce resources, in many cases much scarcer than those of people near urban areas, making it even harder for them to provide themselves with an efficient method or technology to improve the quality of the water that they drink.

In this region, in August 1993, the Nepalese monk, Bhikkhu Maitri, founded the International Buddhist Society (IBS) with the purpose of serving local people and acting as a center of Buddhist activity (Lukacs, 2002). Its mission includes: free medical treatment for the local people, an information center for foreign visitors, and the construction of rest home for the pilgrims.

The health clinic at IBS is run by Dr. Narendra Kumar Mallik, who is responsible for integrated community health programs in 17 of the villages surrounding Buddahnagar (name of village in Lumbini where IBS is located). After relating waterborne diseases to villager sicknesses, Dr. Mallik established a program with the help of 7 women (women motivators). The main purpose of the program is to monitor proper management of water and tube wells, health problems and management, and sanitation practices.

IBS has also been able to partner with two NGOs, Himalaya Exchange and Cross Flow Nepal Trust for the installation of 57 hand pump tube wells, and has been an active host to MIT Master in Engineering students and their work in the development, research and expansion of point-of-use household level water treatment techniques and methods.

Due to the physical, social and economic characteristics of this region, Lumbini was chosen as appropriate area of the present study. Even though there have been several different technologies introduced in Lumbini for water purification, including solar disinfection, and levels of waterborne disease have dropped in many villages, health care fluctuations are still observed within the population, making it an ideal place for the development of my intended study and research.

1.4 Purpose of Study

Studies have proved that improving the quality of drinking water reduces the risks associated with waterborne diseases (Sobsey, 2002). Having this as a target, my research focused on the study of point-of-use (household level) technologies, understanding their advantages, disadvantages, and potential improvements towards the development of a sustainable system. To be able to meet basic needs without compromising the user's health, a drinking water treatment technology has to be technically simple, effective at disinfection, accessible, economic, socio-culturally acceptable, and with potential for distribution.

One of the most promising and accessible technologies for point-of-use and household water treatment is solar disinfection. This system has been shown to dramatically improve the microbiological quality of water, and to decrease the incidence of diarrheal and other infectious diseases in many places around the world (Sobsey, 2002), as well as locally, in Nepal (Khayyat, 2000; Smith, 2001). Looking at the economic side of solar disinfection, solar energy and radiation are free, so even if the materials to build a solar system may seem expensive due to the equipment and technology needed, in the long run, this may be an inexpensive process. These two big advantages, added to the simplicity of the process, were the author's main motivations to continue with a further study of this technology. At a household level, a simple solar disinfection system known as SODIS³ has been widely used. However, some of the disadvantages that users have found are: laboriousness of taking the bottles in and out everyday for solar exposure, the relatively small amount of water that can be treated, and lack of proper management in the acquisition and disposal of the containers used for the system.

The purpose of this study was to review the different solar disinfection experiments and findings related to developing countries with similar social, environmental and political characteristics as the ones seen in Nepal, to develop new ideas to address the shortcomings of the existing SODIS approach, and to implement them through innovative laboratory and field work.

1.5 Hypothesis

The specific hypothesis of this study is that Semi-Continuous Solar Disinfection (SC-SODIS), an innovation of the author built on previously used point-of-use solar disinfection systems, is a sustainable technology with unique and specific characteristics that make it an almost ideal system for use in developing countries.

The invention of a semi-continuous solar disinfection system (SC-SODIS) is an innovation that overcomes limitations and disadvantages of previous point-of-use systems (specifically solar disinfections systems; i.e. SODIS). SC-SODIS promises to become a widely accepted (technologically, economic, and socio-culturally) system.

³ Consists of putting water to be treated in a PET bottle and is exposing it to the sun for a certain amount of time (see Chapters 3 and 4).

This thesis is divided in two sections. The first section gives an overview of solar disinfection systems, comparison with other water treatment technologies and the basics of solar disinfection (Chapter 2), how this technology evolved over the past years, based on studies, findings and applications in developing countries, specifically by previous M.Eng. students in Nepal and Haiti (Chapter 3) , and finally a comparison between the specific solar disinfection systems that have been used, based on the advantages and disadvantages that they present (Chapter 4).

The second section is related to the innovation developed by the author, the SC-SODIS, design considerations for the prototype (Chapter 5), the methodology and field data collected in Nepal during the month of January 2003 to assess the feasibility of the system (Chapters 6 and 7), and a conclusion as to whether or not SC-SODIS can be considered a sustainable drinking water system (Chapter 8). The last chapter of the thesis specifies future studies in the area of water quality control and future developments of the SC-SODIS system that would advance the testing and implementation of this technology, based on difficulties found by the author in the field (Chapter 9).

SECTION I: OVERVIEW OF SOLAR DISINFECTION SYSTEMS

II. POINT-OF-USE HOUSEHOLD LEVELL TECHNOLOGIES

II. POINT-OF-USE HOUSEHOLD LEVEL TECHNOLOGIES

2.1 New Trends in Household Level Technologies.

There have been various measures taken all around the world to resolve water quality and related health problems. The problems of water quality and scarcity have been tackled through water resources management, and/or educational, technical, political, economical, and socio-cultural approaches. In terms of technical approaches there exist mainly three trends: study and application of conventional wastewater treatment plants (to treat municipal, industrial or other wastewater point sources); study and application of existing water purification techniques; and research and development of new wastewater treatment and water purification techniques. These approaches have provided techniques at different levels that go from centralized, to community, to household.

Nowadays, there are many places in developing countries where, local conditions (improper industrial or municipal sewage disposal into water bodies, including aquifers), and poor sanitation practices and facilities lead to the presence of microbial microorganisms in water, causing severe waterborne diseases and death. Most of these places are low income communities, thus expensive purification methods or devices used in developed countries are not feasible. In many of these places drinking water quality has become the default responsibility of final consumers. Thus point-of-use water purifying methods are of great interest.

In recent years, there have been many attempts to create novel purification systems that might meet human consumption quality demands, however, one of the great challenges is to create household-level techniques that are appropriate, i.e. sustainable. Evidence shows that simple, acceptable, low-cost interventions at the household level and community level dramatically improve the microbial quality of water. As a consequence, many techniques have been part of the research of recent years. One important area of this research is solar disinfection, one of the most viable methods, due to its simplicity and economical accessibility.

At this point it is important to remark that technical water treatment solutions cannot be promoted in isolation, they need to be combined with hygiene promotion and training. Hand washing with soap (or other aid), safe disposal of feces and safe water handling and storage (E-Conference, 2002), have been shown to be the behaviors of greatest likely benefit.

The technologies to improve the microbial quality of household water include physical and chemical treatment methods. Some of the physical methods include: boiling of water, water pasteurization, water filtration, settling, UV disinfection lamps, and solar water disinfection. The chemical ones include coagulation-flocculation and precipitation, adsorption, ion exchange and chemical disinfection with germicidal agents (primarily chlorine).

Method	Availability and Practicality	Technical Difficulty	Cost	Microbial Efficacy
Boiling or heating with fuels	Varies	Low-Moderate	Varies	High
Exposure to Sunlight	High	Low-Moderate	Low	Moderate
Plain Sedimentation	High	Low	Low	Low
Filtration	Varies	Low-Moderate	Varies	Varies
Aeration	Moderate	Low	Low	Low

Table 2.1 Physical Methods for Water Treatment at Household Level
SOURCE: Sobsey, 2002

Method	Availability and Practicality	Technical Difficulty	Cost	Microbial Efficacy
Coagulation-flocculation or precipitation	Moderate	Moderate	Varies	Varies
Adsorption	High to moderate	Low to moderate	Varies	Varies with adsorbant
Ion exchange	Low to moderate	Moderate to high	Usually high	Low to moderate
Chlorination	High to moderate	Low to moderate	Moderate	High
Ozonation	Low	High	High	High
Chlorine Dioxide	Low	Varies	High	High
Iodination	Low	Moderate to high	High	High
Acid or base treatment with citrus juice, hydroxide salts, etc.	High	Low	Varies	Varies
Silver and copper	High	Low	Low	Low
Combined system: coag-precip., filtration, chemical disinfection	Low to moderate	Moderate to high	High	High

Table 2.2 Chemical or Physical-Chemical Methods for Water Treatment at the Household Level
SOURCE: Sobsey, 2002

Note: Cost estimates are less than 10\$ U.S. dollars for low, >\$10-100 for moderate and >\$100 for high. Microbial efficiency categories are <1log10 (<90%) for low, 1-2 log10 (90-99%) for moderate and >2 log10 (>99%) for high.

Because they are accessible, simple and economical, some systems have been characterized for microbial efficiency and reduction of waterborne diseases, as well as for community acceptance, sustainability and cost recovery (Sobsey, 2002). Of these systems, the ones most widely used and promising for further development, characterization, implementation and dissemination are: sedimentation, boiling or heating with fuels (pasteurization), water filtration, solar disinfection, UV disinfection, chlorination. Each one of these techniques will be described below in order to address their advantages and disadvantages.

2.1.1 Sedimentation.

This is a simple, low cost household method that consists of plain sedimentation: holding or storing water undisturbed and without mixing long enough for larger particles to settle out or sediment by gravity. This technology helps reduce settleable solids and larger microbes; however, is not able to remove colloidal particles and smaller microbes. It can be used as a pre-treatment to remove settleable solids and turbidity. Its overall reductions of bacteria and viruses rarely exceed 90%.

Sedimentation can be done in simple storage vessels, such as pots and buckets. However, special care has to be taken when recovering the supernatant water, in order to avoid disturbing the sedimented particles.

2.1.2 Boiling or Pasteurization

Boiling and heating of water is the safest water treatment method used to disinfect household water since ancient times. It is effective in killing all waterborne pathogens, and can be applied to all waters, including those with high turbidity or dissolved constituents. This method consists of bringing water to a rolling boil. Some authorities recommend a boiling time of up to five minutes, or one minute at sea level, adding one for every additional 1000 meters in altitude. However, heating to pasteurization temperatures (generally 60°C) for periods of minutes to tens of minutes will destroy most waterborne pathogens of concern; even heating to as little as 55°C for several hours has been shown to reduce a large variety of non-sporeforming bacterial pathogens, viruses and parasites. One of the recommendations for storage is to keep the water in the same container where it was boiled, and cover it with a lid.

The main disadvantage of boiling water is the large amount of energy required, making it relatively expensive, and inaccessible for the poorest section of the population in developing countries, due to scarcity and high cost of fuels and the lack of sustainable biomass or other renewable energy resources technologies, or fossil fuels in the region. This has turned into a concern in places like Nepal, where deforestation due to the burning of wood as a fuel is a serious environmental problem.

Microorganism	Temperature for 100% Destruction		
	1 Min	6 Min.	60 Min
Enteroviruses			62°C
Rotaviruses			63°C for 30 Min
Faecal Coliforms	at 80°C complete destruction		
Salmonellae		62°C	58°C
Shigella		61°C	54°C
Vibrio Cholera			45°C
Entamoeba Hystolytica Cysts	57°C	54°C	50°C
Giardia Cysts	57°C	54°C	50°C
Hookworm Eggs and Larvae		62°C	51°C
Ascaris Eggs	68°C	62°C	57°C
Schistosomas Eggs	60°C	55°C	50°C
Taenia Eggs	65°C	57°C	51°C

Table 2.3 Thermal Resistance of Microorganisms

2.1.3 Water Filtration

Filtration is another ancient and widely used technology that removes particles and microorganisms of various sizes from water. There is a wide variety of filter media and filtration processes available for household treatment of water that will remove a high fraction of solid matter, but may not remove all of the microorganisms. Some of these are: ceramic candle filters, stone and sand filters, vegetable and animal-derived depth filters, septum and body feed filters, etc.

The practicality, ease-of-use, availability, accessibility and affordability of the different filtration media or methods used vary widely and are usually related to local

factors. Commercially produced filters in different developed and developing countries are relatively costly (e.g. Brita or Katadyn). In addition, in some developing countries these lack quality control parameters and are of limited efficiency for microbiological removal. Recent work and research on POU (point-of-use) household filters, such as ceramic water filters (the Potters for Peace Filtron in Nicaragua, TERAFILE terracotta filter in India, candle filters in Nepal, Bangladesh, etc), biosand filters (Concrete Filter, Bench-Scale Filter, Devnor Filter), or arsenic filters (Biosand-Arsenic Filter, Two-Kolshi Filter, Three-Kolshi Filter) overcome many of the water quality problems, and are made of locally available materials at low cost.

2.1.4 Chlorination

Nowadays, the technique mostly used for water disinfection is chlorination due to its high efficiency in destroying waterborne pathogens, (with the exceptions of *Cryptosporidium parvum* oocysts and *Mycobacteria* species, where different factors such as free Cl, pH, temperature and contact time are involved). At very low doses (mg/L) and contact times of about 30 min, chlorine generally inactivates 99.99% of enteric bacteria and viruses. However there are certain localities where social acceptability has been doubtful due to the taste that it gives to water (Martin, 2000) and the presence of different by-products. Furthermore chlorination may require skilled application due to the fact that it is a corrosive and hazardous substance.

Chlorination is referred to as free chlorine treatment. Some of the most practical forms of chlorine for household water treatment are liquid sodium hypochlorite, solid calcium hypochlorite and bleaching powder (chloride of lime; a mixture of calcium hydroxide, calcium chloride and calcium hypochlorite).

2.1.5 UV Radiation

Although the germicidal activity of irradiation with UV lamps has only been known since the early part of the 20th century, this method of disinfection has a well-documented ability to inactivate some of the most resistant waterborne, chlorine-resistant protozoans, *Cryptosporidium parvum* oocysts and *Gardia lamblia* cysts, at doses below 10mJ/cm².

Disinfection is usually accomplished with mercury arc lamps containing elemental mercury and an inert gas in a UV-transmitting tube (usually quartz). At a household level, these lamps are submerged in water or mounted above a thin layer of the water to be irradiated.

This system does not create taste, odors or toxic chemical by-products; however, the lamps do need an electrical source and need to be cleaned and replaced periodically. Moreover, the technology lacks residual disinfectant for further use.

2.1.6 Solar Disinfection

Solar Disinfection is a very simple water treatment method, which uses solar radiation (in the UV-A wave length) to inactivate and destroy pathogenic bacteria and viruses present in water. This methodology combines the germicidal effects of increased temperature and UV radiation. This synergistic effect is what determines its efficiency to kill or inactivate pathogenic microorganisms during solar exposure. Various solar

treatment systems have been under study, but the one most widely accepted due to its simplicity and cost is the SODIS system first studied by Aftim Acra from the American University of Beirut and later developed by scientists at the Swiss Federal Institute for Environmental Science and Technology (EAWAG), and its many collaborators and partners.

Some of the disadvantages presented by this methodology are the availability of appropriate containers for the water to be treated, dependence on sunlight for disinfection (a function of latitude, cloud coverage, pollutants in the air, etc.), difficulty of treating turbid waters, lack of residual disinfectant, the length of time needed to treat water, and the drudgery involved in handling multiple bottles.

The following section will discuss in depth the technical fundamentals of this technology, its principles, components and main characteristics.

It is important to recognize that a further problem is that water collected for domestic use is often contaminated by unsafe consumer storage and/or handling practices at the point of use. Part of this problem is unsanitary and inadequate (open, uncovered or poorly covered) water collection and storage containers, the practice of unsanitary methods to dispense water from household storage vessels (contaminated hands), and inadequate cleaning and maintenance of vessels.

2.2 Solar Disinfection

There have been many studies done around the world using Solar Disinfection. The main interest in developing this kind of technology is the low costs involved in its application and its simplicity: “the sun kills the harmful bacteria present in contaminated water.”

These studies have shown that various bacteria and viruses (including fecal coliforms *E.Coli* and *enterococci*, *rotavirus*, *coliphage f2* and *encephalomyocarditis*) of serious concern in different populations are reduced extensively when exposed to solar radiation (Sobsey, 2002).

2.2.1 Solar Radiation

Every day the sun radiates huge amounts of solar energy of wavelengths that cover the ultraviolet, visible, and infrared bands; however, not all gets to ground level due to phenomena involving reflection, scattering (radiation deflected in all directions), and absorption of radiation to different degrees by atmospheric constituents. The amount of reduction varies for different wavelengths, depending on the length of the atmospheric pathway; this is affected by the altitude of the sun, latitude, season, cloud coverage, and atmospheric pollutants. Table 2.4 shows the wavelength range of the different spectral bands and their atmospheric effects.

Band	Wavelength (nm)	Atmospheric Effects
Gamma ray	<0.03	Completely absorbed by the upper atmosphere
X-Ray	0.03 – 3	Completely absorbed by the upper atmosphere
Ultraviolet, UV		
UV (B)	3 – 300	Completely absorbed by oxygen, nitrogen, and ozone in the upper atmosphere
UV (A)	300 – 400	Transmitted through the atmosphere, but atmospheric scattering is severe
Visible	400 – 700	Transmitted through the atmosphere, with moderate scattering of the shorter waves
Infrared, IR		
Reflected IR	700 – 3000	Mostly reflected radiation
Thermal IR	3000 - 14000	Absorption at specific wavelengths by carbon dioxide, ozone, and water vapour, with two major <i>atmospheric windows</i>

Table 2.4 Spectral Bands of Incoming Solar Energy and Atmospheric Effect.
SOURCE: Acra et al, 1984

Total radiation received at ground level includes direct radiation, as well as indirect or diffuse radiation (caused by reflection and scattering). The percentage of diffuse radiation may be more than 10% of the total solar radiation during daylight hours, but could go up to 20% during sunrise and sunset (Acra et al, 1984). This makes evident that in the presence of clouds, and during the early morning and late afternoon, the total solar radiation received at ground level will be greatly reduced. It is very important to be aware of these facts in order to properly utilize solar radiation towards the destruction of microorganisms.

As said before, the latitude is one of the variables on which solar radiation that gets to ground level depends. It is important to have an idea of the solar radiation global distribution, in order to evaluate the feasibility of solar radiation studies in specific regions. Acra et al (1984), divided the total solar radiation into four belts around the world in terms of intensity, as shown in Figure 2.1.

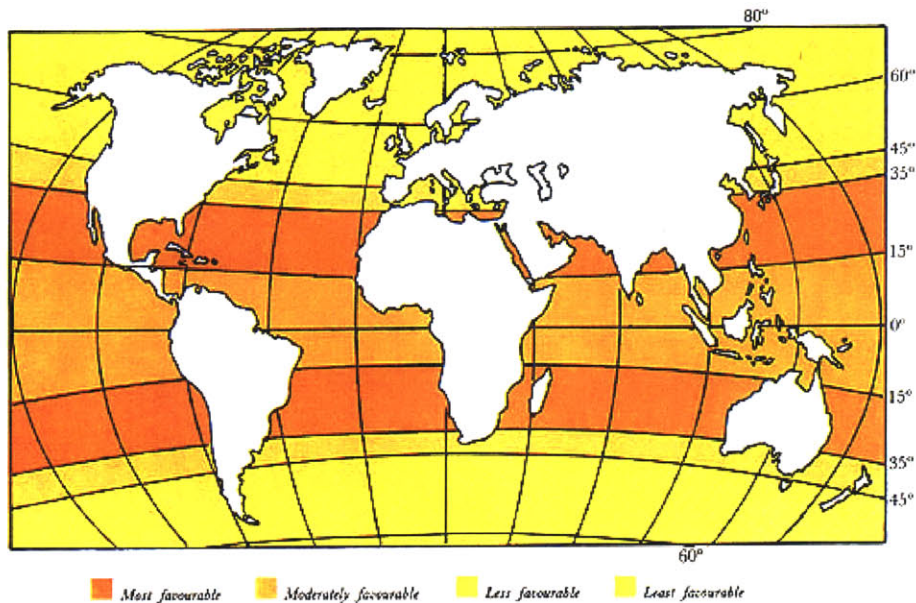

Figure 2.1 Worldwide Distribution of Solar Radiation into Belts Indicating Feasibility of Solar Applications
SOURCE: Acra, *et al*, 1984

- *Most favorable belt.* Lies within 15°N and 35°N, as well as 15°S and 35°S latitudes. This region has the greatest amount of radiation (more than 90% comes as direct radiation), due to limited cloud coverage and rainfall (less than 250mm per year), and 3,000 hours of sunshine per year (Acra et al, 1984).
- *Moderately favorable belt.* Lies within 15°N and 15°S. The reduction of solar radiation is mainly due to high humidity, which enhances cloud formation. However, solar radiation is almost the same throughout the whole year, with only slight seasonal variations.
- *Less favorable belt.* Lies within 35°N and 45°N, as well as 35°S and 45°S latitudes. The reduction of solar radiation in this region is mainly due to highly marked seasonal variations.
- *Least favorable belt.* Beyond 45°N and 45°S. Solar radiation in this region is reduced to almost half due to diffusion, and even more in winter due to the frequent and extensive cloud coverage (Acra et al, 1984)

As we can see from figure 2.1, many of the developing countries lie within the most favorable or moderately favorable belt regions. This supports the feasibility of using solar radiation for inactivating bacteria in these regions of the world

2.2.2 Disinfection Effects of Solar Radiation

Solar disinfection is based on the fact that UV light in a range of 315 to 400 nm , also known as UV-A, is able to cause DNA damage in living cells, thus inactivating the

cell. This fact has been corroborated in various studies (Acra et al, 1984, Moulton, 1999; Wegelin et al, 1994, ENPHO, 2000, Khayyat, 2000; Smith, 2001; SANDEC, 2002a).

2.2.3 How does solar disinfection work?

Ultraviolet (beyond violet) light is of shorter wavelength than visible light and with higher energy (from 200-400nm). It is divided into three main components: UV-A, UV-B and UV-C, however, UV-C does not pass through the atmosphere due to its reaction with oxygen in the upper layer of the atmosphere. The effect of UV-B may also be irrelevant when using PET containers for solar disinfection processes as this material absorbs wavelengths within the UV-B spectral range (SANDEC, 2003b).

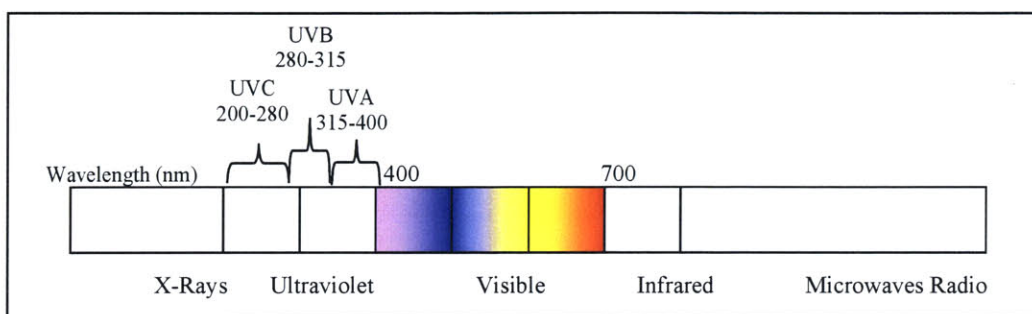

Figure 2.2 Radiation Bands and Wave Length Ranges

UV-A is the component present in sunlight believed to be mostly responsible for the inactivation of microorganisms. The exact reaction paths and chemical/compounds involved in the interactions of microorganisms with UV light are not known. Some studies suggest that UV-A and UV-B light directly interacts with essential components of living cells, changing the molecular structure and leading the cell to death (SANDEC, 2002b). Others suggest that absorption of UV-A and UV-B light occurs through photosensitizers leading to the production of highly reactive oxygen species that cause strand breakage and base changes in the nucleic acids of microorganisms (Reed, 1996; Smith, 2001). In some cases these effects may be repaired by some microorganisms. In this case the damage caused to the cell will depend on its ability to repair, compared to the inactivation rates of the technology used. Different studies show that exposure of microorganisms to a threshold of $500\text{W}/\text{m}^2$ (integrated energy over the entire spectrum) for approximately six hours assures total inactivation, leaving the cells without the ability to reverse the lethal effects caused by UV-A radiation (SANDEC, 2002a, Wegelin, 1994).

According to SANDEC, 2002c, there are studies that prove the inactivation of the following microorganisms:

- Bacteria: *Escherichia coli* (*E.coli*), *Vibrio cholerae*, *streptococcus faecalis*, *Pseudomonas aeruginosa*, *Shigella flexneri*, *Salmonella typhi*, *Salmonella enteritidis*, *Salmonella partyphi*.
- Viruses: *Bacteriophage f2*, *Rotavirus*, *Encephalomyocarditis virus*.
- Yeast and Mold: *Aspergillus niger*, *Aspergillus flavus*, *Candida*, *Geotrichum*.

Other types of microorganisms may also be potentially inactivated by solar radiation; however, they have not been researched yet. These includes *Entamoeba histolytica* and *Gardia intestinalis*, which are inactivated after one minute at temperatures above 57°C (SANDEC, 2002b). However work by Khayyat (2000), Smith (2001) and ENPHO (2002) suggest that two day exposure is necessary under challenging environmental conditions (clouds, pollution, cold temperatures, etc.) to achieve total inactivation.

It is of great importance to recognize that solar disinfection will not result in sterile water, since different natural water microorganisms such as algae may be well adapted to the environmental conditions of the solar disinfection system. However, it is also important to mention that these organisms are not considered a danger to human health.

2.2.4 Effect with Oxygen.

As we saw before, reactive oxygen species such as superoxides, hydrogen peroxide (H_2O_2), and hydroxyl radical (-OH), are responsible for the lethal changes caused by UV-A at a cellular level in microorganisms. Based on these findings, many studies have suggested the presence of oxygen as an additive for improving solar disinfection systems. Photo-oxidative disinfection will then work, if the oxygen concentration present in the system is large enough to create oxygen photoproducts (Figure 2.3).

Previous work with and without oxygen has shown that in most cases increasing the amount of oxygen present in the system improves the overall removal efficiency of the system.

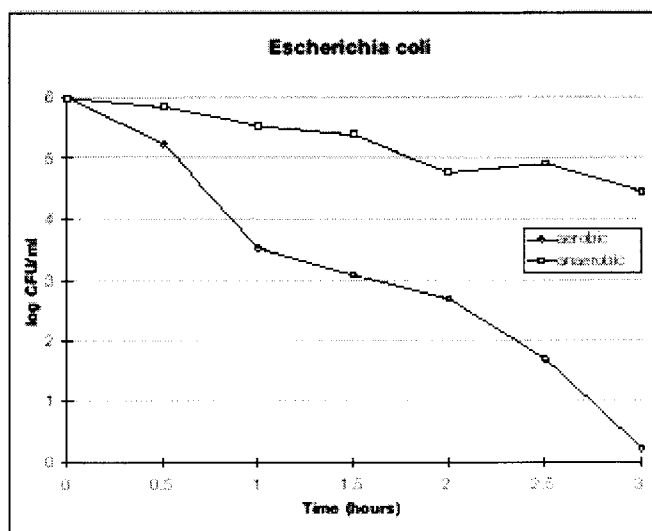

Figure 2.3. Inactivation of E. Coli Under Aerobic and Anaerobic Conditions
SOURCE: SANDEC, 2002b

However there has been some discussion on this point (E-Conference, 2002), because on the one hand, the presence of oxygen might help create lethal photoproducts for the microorganisms, but on the other, it might impede the solar radiation from entering into the contaminated water with the same efficiency due to reflection.

2.2.5 Synergistic Effect with temperature

In addition, water also absorbs red and infrared light creating heat, which could lead to pasteurization if it reaches a certain temperature (see Table 2.3). The combined effects of radiation and heating to temperatures of 50 or 60°C, provide a synergistic germicidal effect against viruses, bacteria and parasites, more powerful than each one of them on their own (Sobsey, 2002).

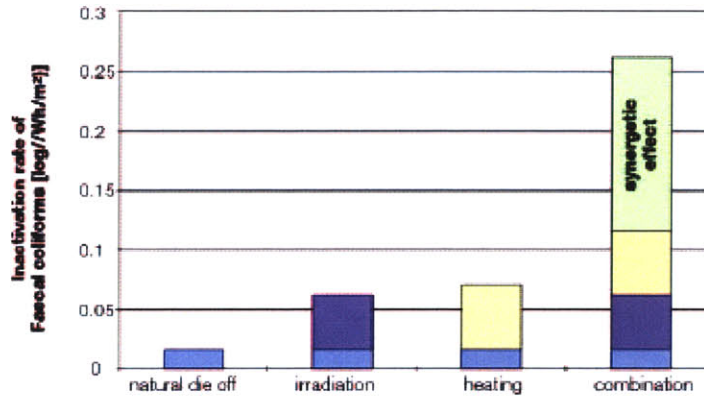

Figure 2.4 Synergetic Effect of UV-Radiation and Temperature on Fecal Coliforms in Raw Water
SOURCE: SANDEC, 2002b

According to Martin Wegelin, a water temperature of about 30°C, and a total fluence of 555Whr/m² UV-A light (340-450W/m² radiation during approximately 6 hours of mid-latitude midday summer sunshine) is enough to cause a 3-log reduction of fecal coliforms in the exposed water. At this temperature, the only cause of the inactivation of microorganisms is solar radiation. However, with a temperature of about 50°C, a 3-log reduction of fecal coliforms occurs with an irradiation of only 140Whr/m². This is equivalent to only one hour of exposure time (SANDEC, 2002b).

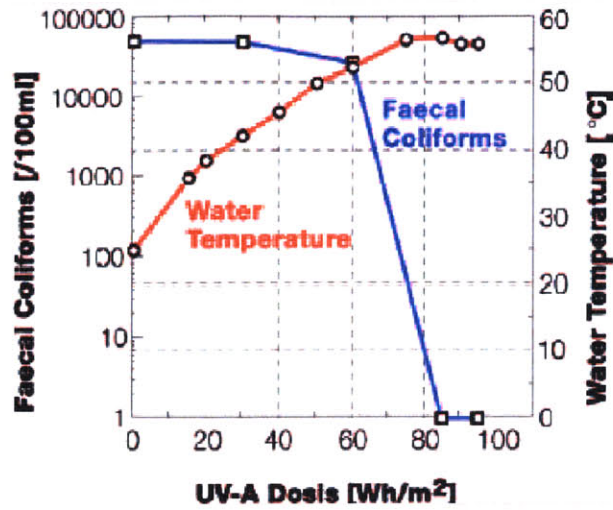

Figure 2.5 Inactivation of Faecal Coliforms in a PET-bottle on a Black Underground
SOURCE: SANDEC, 2002b

2.2.6 Turbidity

Turbidity is a critical variable with regard to the efficiency of solar radiation for inactivation of microorganisms. Turbidity is a measure of the degree to which light is scattered by suspended particulate material and soluble colored compounds in the water. This measurement provides an estimate of the cloudiness present in the water due to clay, silt, finely divided organic and inorganic matter, plankton and microscopic microorganisms (Natural Resources Research Institute, 2003). Turbidity is measured in Nephelometric Turbidity Units (NTU) (refers to the turbidimeter called Nephelometer in Russian), and gives a measure of scattered radiation.

As previously mentioned the atmosphere reduces the total solar radiation reading at ground level due to scattering. In turbid water, we have the same effect. The presence of suspended solids scatters (impedes penetration of) the solar radiation that enters in the water, thus reducing the inactivation effect of solar disinfection.

Many researches who have performed solar disinfection studies have agreed that solar disinfection should only be used for water with turbidity below 30 NTU (Sobsey, 2002, Wegelin et al, 1994, E-Conference, 2002, Acra et al, 1984). Some recommendations for treatment of water with turbidity above 30 NTU prior to solar disinfection are filtration (passing water through a porous medium), sedimentation (letting water stand still for a certain amount of time), or decantation of bigger suspended particles in the surface (pouring out components of lower density than water present on the top of the container with polluted water) .

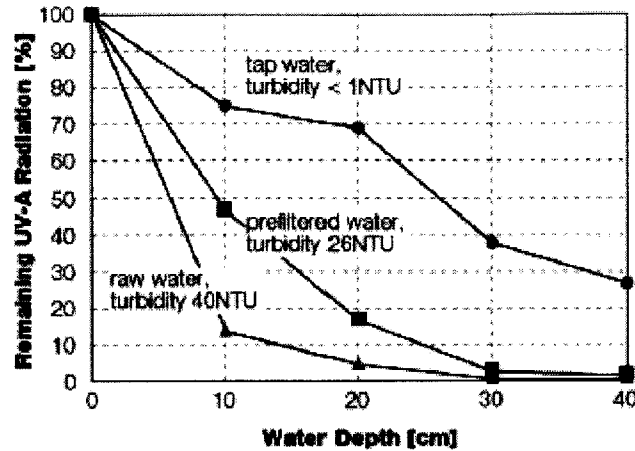

Figure 2.6 Reduction of UV-A Radiation as a Function of Water Depth and Turbidity
SOURCE: SANDEC, 2002b

From Figure 2.6, we are able to see also the effect of depth of water with different turbidities. This shows the importance of reducing the turbidity of the water for treatment, and the importance at different depths.

2.2.7 Efficiency of inactivation

Studies done in different developing countries by different institutions such as EAWAG/SANDEC, IMTA (Instituto Mexicano de Tecnologia del Agua), ENPHO (Environmental and Public Health Organization), MIT (Massachusetts Institute of Technology), American University of Beirut, etc., show that solar disinfection has almost a 100% removal efficiency after two days of exposure to solar radiation under different climatologic conditions (using *E.coli* as microbial indicator). Exceptions, show in all cases efficiencies above 90% after two days (see tables 2.5 and 2.6)

Data collected by SANDEC in workshops in Bolivia, Honduras, Ecuador and Peru between 1999-2001, and a project in Nicaragua (1999-2002), show that in all cases, the efficiency of the analyzed samples was always above 90%.

Efficiency level	% of samples	Nr of samples
> 99,9 %	81.2	95
99-99,9%	9.4	11
90-99%	4.3	5
< 90%	5.1	6
Total	100	117

Table 2.5 Solar Disinfection Efficiency During Demonstrative Workshops
SOURCE: SANDEC, 2002b

Efficiency	% of samples	Nr of samples
> 99,9 %	64.6	31
99-99,9%	0.0	0
90-99%	20.8	10
< 90%	14.6	7
Total	100	48

Table 2.6 Solar Disinfection Removal Efficiency at User Level (example from SODIS project in Nicaragua)
SOURCE:SANDEC, 2002b

Other type of studies, like the ones conducted in Mexico at the Instituto Mexicano de Tecnologia del Agua (Mexican Institute of Water Technology), IMTA, indicate the exposure time required for total inactivation of different microorganisms in typical climate conditions of Mexico.

Microorganisms	Required time exposure for 100% inactivation
Total Coliforms	4 to 6 hrs.
Escherichia coli	4 to 6 hrs.
Virus	3 hrs.
Vibrio Cholerae	2 hrs
Bacteria	
Pseudomonas aeruginosa	15 min
Salmonella flexneri	30 min
S. typhi and S. enteritidis	60 min
S. paratyphi B	90 min
Yeast and Mold	
Asperquillus niger	3 hrs.
Aiflavus	3 hrs.
Candida y Geotrichum spp	3 hrs.
Penicillium	6 to 8 hrs

Table 2.7 Results IMTA for Inactivation of Microorganisms Under Normal Mexican Climate Conditions
SOURCE: Martin, 1999

2.2.8 Microbial indicators

The main application for solar radiation has been directed towards developing countries. With this in mind, indicators of microbial presence in treated and untreated water should be simple and inexpensive. However most of the tests found in the field for detecting waterborne pathogens are not. Proposals of different investigators in the E-Conference (2002) agree that a fecal pollution indicator should be used to evaluate the efficiency of solar disinfection (either fecal coliforms or *E.coli*). However, discussions about which was the best method, membrane filtration, most-probable-number, or presence/absence tests ended up in disagreement. This was mainly due to the stringent level of the criteria taken into consideration. Some said the criterion should be 0 fecal coliforms per 100ml (WHO, 1997), however, classifies the presence of 1-10 fecal coliforms or *E.coli* per 100ml in water supplies as low risk, and a concentration of 10-100 CFU/100 ml as an intermediate risk.

Fecal coliforms that includes *E. coli* and *Klebsiella*, meet the requirements established by EAWAG/SANDEC for the fecal indicator microorganism:

- It is present in high number in human faeces
- It is detectable by simple methods
- It does not grow in natural waters
- It is persistent in water and comparable to other water-borne pathogens

Care should be taken when conditions might suggest presence of enteroviruses, *Cryptosporidium*, *Gardia* and *Amoebae*, that are more resistant than *E. coli*, and that might not be detected by fecal indicators.

It is important to mention that neither total coliform bacteria nor total count of bacteria can be considered as indicators, due to the fact that many coliforms present within these groups are naturally abundant in the environment without representing any potential hazard for human health.

III. PREVIOUS SOLAR DISINFECTION STUDIES AND APPLICATIONS

III. PREVIOUS SOLAR DISINFECTION STUDIES AND APPLICATIONS

Treatment of water with solar radiation is an ancient technique, practiced in ancient India more than 2000 B.C.E. (Sobsey, 2002). In recent years, people of the 20th and 21st century have again started to recognize and consider this technique as a potential tool to alleviate waterborne diseases in developing countries all around the world.

3.1 American University of Beirut, Lebanon

The pioneers of the modern use of solar radiation as a disinfection system were a team of Lebanese researchers, headed by Professor Aftim Acra, from the Department of Environmental Health at the American University of Beirut, Lebanon, working on research towards providing a simple solution for water disinfection. This study led them to discover a simple method based on exposing the contaminated water to solar radiation for a given period of time. One of the aims of the research was to provide an “affordable” method to be used mainly by developing countries (Acra et al, 1984).

First Phase of experimental work

The study at the American University of Beirut started in July 4, 1979 and over a period of more than two years focused mainly on assessing the possibility of solar disinfection of small quantities of drinking water to satisfy the needs of families in developing countries. These experiments involved putting artificially contaminated water in different types of containers (transparent, clear, colored glass or plastic) that also varied in shape (round, conical, cylindrical), and exposing them to the sun's rays for a certain period of time.

The containers were examined bacteriologically (total coliforms and total bacterial population) prior to the experiment, and every 15 or 30 min during their exposure to solar radiation; when the solar intensity reaches its highest levels. Some experiments were also conducted indoors in order to compare natural and artificial illumination and complete darkness. The standard plate count and membrane filter technique were used to obtain an estimation of the total bacterial counts and total coliform densities.

Results and Conclusions

From the analysis of the data collected, and the results of each set of experiments, they observed as a general rule that the bacteria contaminating water from fecal sources are susceptible to destruction upon exposure to solar radiation (Acra et al, 1984). They also found that the rate at which these bacteria were inactivated depended on different factors. The ones they identified as the most important were:

- a) *The intensity of solar radiation during exposure* (which at the same time depends on different factors listed in Section 2.1.1). According to their results, data fit an exponential decline curve (like for other disinfectants such as chlorine and iodine). Figure 3.1 shows these exponential survival curve patterns where exposure times decrease as the amount of radiation increases from 95 minutes in natural illumination, to 630 minutes with artificial illumination.

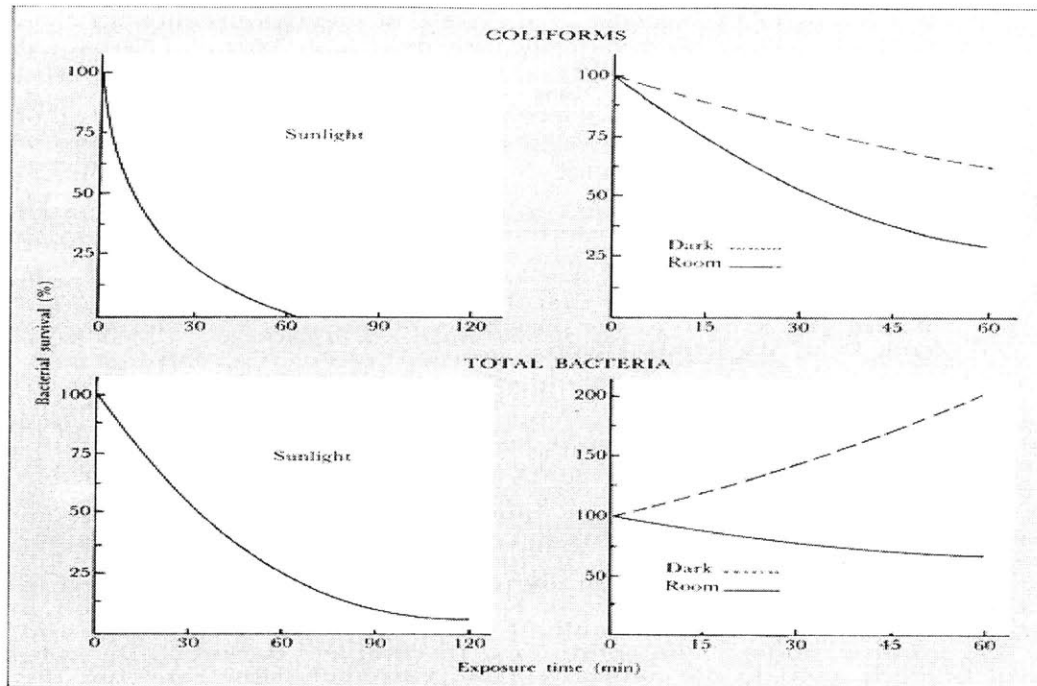

Figure 3.1 .Germicidal Effect of Solar Radiation on Bacteria Contaminating Water Held in Blue Glass Containers. Identical Samples of Water kept in the Dark and in a Room Served as Controls for Comparison. SOURCE: Acra et al, 1984

- b) *The type of bacteria present in the contaminated water, the nature and composition of the medium, and the presence of nutrients.* The exposure time required to have complete destruction of different microorganisms was found to be as follows: *P. aeruginosa* 15 minutes; *S. flexneri* 30 minutes; *S. typhi* and *S. enteritidis* 60 minutes; *E. coli* 75 minutes; *S. paratyphi B* 90 minutes; and coliform bacteria 80 minutes. These results suggest the idea of *E. Coli* and coliform bacteria as microorganism indicators, due to their somewhat higher resistance to lethal effects of solar radiation. In the study concerning molds and yeast, the most resistant one, *penicillium*, required 6-8 hours. Another result presented was the lack of bacterial regrowth in a monitored 5-day-storage-water container under ordinary room conditions. However, the results presented cannot be generalized since they are subject to the microbial indicators used (for which *E.coli* is considered better than total coliform or total bacteria) and the climate. Further studies should be made under different conditions and exposure times.
- c) *UV-A as an effective component of solar radiation involved in microbial destruction, and violet and blue light to a lesser extent.* This hypothesis, however, requires verification by specific experiments oriented towards defining maximum absorption peak within the UV-A range.
- d) *The characteristics of the containers used.* Results showed that colorless containers were able to decrease the time of radiation exposure: 70 minutes for colorless polyethylene bags to 1,050 minutes for dark brown bottles. These results were obtained studying the spectral transmittance for different containers to achieve the optimal wavelength for light transmittance, and an action spectrum for

coliform inactivation. They concluded that the best containers were colorless plastic or glass containers, which would be able to transmit the UV-A. For colored containers the descending order of solar penetration was blue and violet>green>yellow>orange>red. They also found that the thinner the walls of the container, the better, that round-shaped containers worked best, and that these should be closed to prevent external recontamination. Finally they found that bottles exposed with an inclination angle of the latitude received larger amounts of solar radiation.

- e) *The turbidity of water and its depth.* Suspended or colored solids present in turbid water obstruct the passage of solar radiation through water. As the depth of water increases, the extent of solar radiation penetration diminishes, and thus the efficiency of the method. Pre-treatment was recommended in order to decrease the presence of suspended solids or other particles present in the water.

Second Phase of experimental work (1986-1987)

Later on, a second study conducted by Aftim Acra (Acra et al.,1987) in 1986 and 1987 looked at the possibility of applying the same fundamental principles to a continuous-flow system (Figure 3.2). The investigations were conducted using continuous flow solar disinfection units of capacities of about 5 and 10 L, and with short exposure times to avoid fluctuations in the amount of solar radiation received.

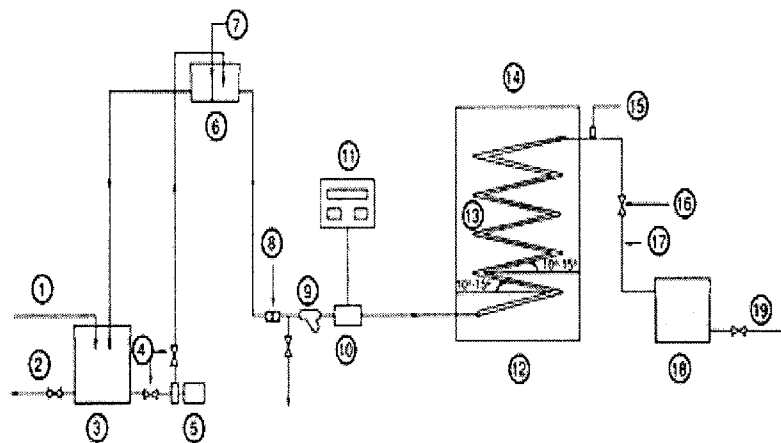

Figure 3.2. Layout of Type I Solar Reactor System. 1. Water feed; 2. Drain; 3. Storage reservoir containing contaminated water; 4. Gate valve; 5. Pump; 6. Constant head-tank; 7. Overflow; 8. Flow regulator; 9. Strainer; 10. Flow meter; 11. Digital flow meter panel and control; 12. Solar reactor; 13. Serpentine transparent tube; 14. Inclined from support (facing south); 15. Air valve; 16. Globe-valve; 17. Effluent; 18. Storage tank; 19. Distribution.

SOURCE: Acra et al, 1987

In these studies the microorganisms used as indicators, due to their relatively high resistance were: *Streptococcus faecalis*, coliforms, and *E.coli*. The experiments considered bacterial counts as the dependent variable, and temperature, flow rate and solar radiation as the independent variables. To calculate the exposure time, both reactors considered uniform flow (plug flow) through the reactors without taking into

consideration any possible turbulence resulting from temperature or density gradients. These results showed:

- a) UV-A has an inactivation effect on the studied representative microorganism.
- b) Calculation of spectrum curves and relative inactivation rates studied at different wavelengths corroborated that UV-A corresponds to the range of wavelengths mainly responsible for the inactivation of microorganisms.
- c) *Streptococcus faecalis* is more resistant to solar radiation than *E coli*, as the exposure time for inactivation turned out to be longer.
- d) Results of batch and continuous-flow, showed that high initial concentrations (10^8 - 10^{10} viable cells/mL) of bacteria are less sensitive to solar radiation exposure, as compared with low or medium concentrations.
- e) Even though it was expected to be a potential problem with this type of reactor, no visible growth of phytoplankton occurred on the inner surfaces of the solar reactors. This could be due to the lack of nutrients and soluble gases present in the system. However, the period of time over which observations for biofouling were made are not specified. Thus, it is difficult to say if longer periods of time would present this problem.

3.2 Integrated Rural Energy System Association (INRESA)

Motivated by Acra et al's findings related to solar disinfection, the Integrated Rural Energy System Association (INRESA), an associated program of the United Nation's University, promoted a network project in 1985 to encourage different local research institutes to continue research on solar disinfection and to cooperate in the dissemination of the new technology.

The field research was carried out in research institutes in different parts of the world: Peru, Colombia, Nigeria, Sri Lanka and Egypt. However, due to the lack of standardized research, results were inconclusive. Nevertheless, some of the findings obtained during the period of research were:

- a) Acra's findings were accurate. Solar radiation inactivates microorganisms.
- b) Solar radiation works effectively with a radiation intensity of at least 500W/m² (all wavelengths) for a period of 5 hours if the concentration of the water to be treated does not exceed 1,000 fecal coliforms/100ml.
- c) At the temperature used (lower than 50°C), variations in the water temperature do not seem to have any important role in the inactivation rate of bacteria.

Results from the research done in the five institutes also included some general recommendations, such as the use of clear transparent bottles and the use of water with turbidity under 30 NTU.

3.3 EAWAG/SANDEC

The Swiss Federal Institute for Environmental Science and Technology and SANDEC, EAWAG's Department of Water and Sanitation in Developing Countries, started to do laboratory research on solar radiation as a water disinfection system in the year of 1991. The main purposes of the studies were to assess the potential of this new method to inactivate different microorganisms, mainly bacteria and viruses, and to help in the promotion and dissemination of the technology. Different sets of experiments were conducted first in the laboratory and then in the field.

First Phase of Investigation

Studies done during 1994, conducted by Wegelin, Canonica, Meschner, Fleischmann, Pezaro and Metzler, verified data previously reported by Acra. Some of the new findings from their experiments were:

- The wavelength responsible for the germicidal effect of solar radiation is UV-A. This was shown through experiments of inactivation of different microorganisms at different wavelength.
- In order to get a 3-log reduction of *E.coli*, a solar radiation fluence of 555Whr/m² dose (wavelengths between 350-450nm) was required (Wegelin et al, 1994). This radiation is equal to approximately 5 hours of solar exposure in a midday mid-latitude summer sunshine.
- Temperature-Solar radiation synergistic effect. Data obtained from their laboratory research revealed the presence of a synergistic effect with solar radiation and temperature rise, resulting in a more efficient germicidal effect. Later field tests corroborated this effect. They also found that the rate of UV-A microbial inactivation increased within the temperature range of 20-50°C
- Dissolved natural organic matter hinders water disinfection due to decreased penetration of solar radiation.
- Methylene blue, used as a photo-sensitizer, increases the rate of solar water disinfection.
- Experimenting with viruses, they found that *bacteriophages* and *rotavirus f2* are inactivated at about the same rate as other microorganisms, while picornavirus was twice as resistant.

Second Phase of Investigation

A second study done during 1997 included batch reactor tests as well as a study of continuous disinfection system with the purpose of finding the optimal flow rate allowing total inactivation of microorganisms. Two types of continuous disinfection systems were tested, one that would combine the synergistic effect of solar disinfection and temperature increase (SODIS; Figure 3.3), and a second one that would only take into consideration the temperature effect (SOPAS; Figure 3.4).

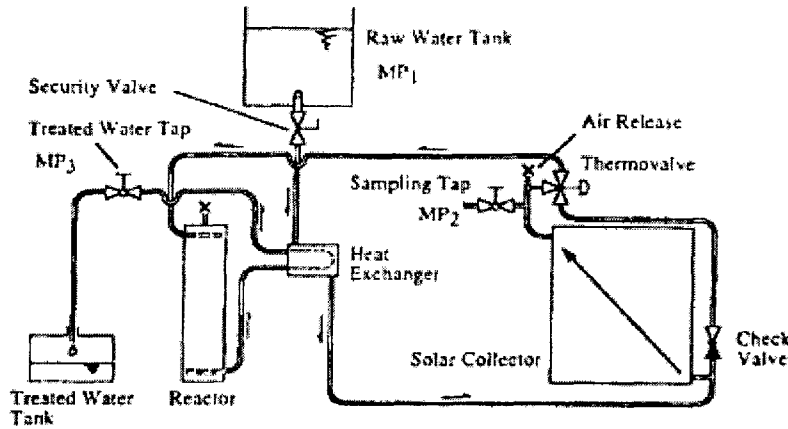

Figure 3.3 SODIS System Scheme

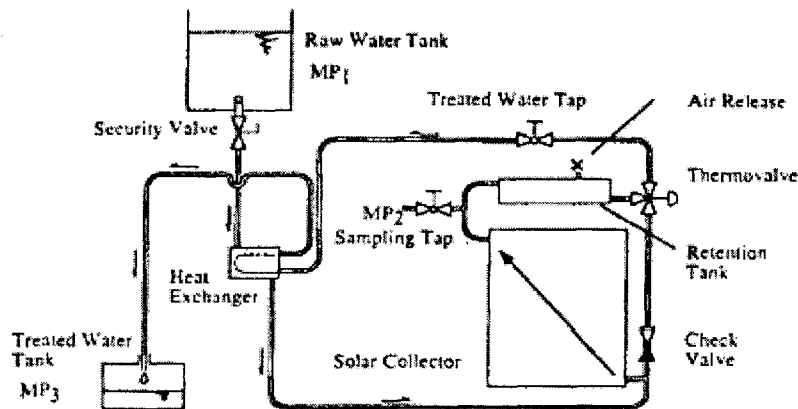

Figure 3.4 SOPAS System Scheme

The results from this second phase of investigation for the batch reactor system were:

- a) UV-A radiation decreases rapidly with increasing water depth.
- b) Transmission losses of UV-A solar radiation are: ~30% for plastic bottles, ~20% for glass bottles, and ~10% for plastic bags.
- c) Black metal supports were found appropriate to enhance the temperature increase.
- d) Plastic bags (in the black metal supports) heated up faster due to more contact.
- e) Intermittent UV-A doses do not necessarily lead to a need for longer exposure times for the inactivation of microorganisms. Some microorganisms like *Vibrio cholerae* are able to recover; however, that is not the situation in all cases (e.g. fecal coliforms) where microorganisms need very long periods of time to recover. However, kinetics of different microorganisms require further study.
- f) Fast inactivation rates were observed up to 29 NTU. Pretreatment is then recommended to speed up inactivation for water with turbidity above 29 NTU.

Results from the continuous disinfection systems:

- a) Due to wide variability in temperature on account of the climate, the efficiency of SOPAS was low.
- b) The SODIS continuous reactor was ineffective in inactivating pathogen microorganisms in cloudy weather.

Due to the complexity and high cost of these two continuous disinfection systems, recommendations made consisted of using them for institutions and communities rather than at the household level.

The next step taken by EAWAG/SANDEC was to field-test the socio-cultural acceptance and affordability of the system developed by Acra, Solar Water Disinfection (named SODIS for short), in different demonstration projects, oriented towards a target population: areas in developing countries without access to drinking water. According to their results, the response to and interest in SODIS by different communities was very positive (Wegelin et al, 1994).

As a result, beginning in 1999, EAWAG/SANDEC started a program of worldwide dissemination of SODIS in the target populations of different developing countries, including: Latin American countries, Indonesia, Sri Lanka, India, Nepal, Pakistan, Uzbekistan, Kenya, South Africa, Angola, etc. The mission of SANDEC in these projects was as a partner providing information material and promotion strategies, including SODIS publicity campaigns at an international level. Financial support has been provided by different institutions: Swiss Agency for Development and Cooperation, Simavi World Water Fund (Bolivia and Indonesia), AVINA Foundation (Latin America) and SOLAQUA Foundation (Africa and Asia).

Currently, some of the international or local agencies working in collaboration with SANDEC to promote, apply and monitor the use of SODIS as a disinfection system are: Simavi World Water Fund (Bolivia and Indonesia), Fundación SODIS, SODIS Bolivia and Centro de Aguas y Saneamiento Ambiental (Bolivia), Yayasan Dian Desa (Indonesia), AVINA Foundation (Latin America), SOLAQUA foundation (Africa and Asia), the Swiss Tropical Institute (Switzerland), JDA International (Usbequistan), Environmental Concern (Thailand), Ningxia Sanitation and Antiepidemic Station (China), COSI Foundation for Technical Cooperation, Environmental and Public Health Organization (Nepal), Global Resources Institute, International Buddhist Society (Nepal), Community Action Program (Pakistan), League for Education and Development (India), Christian Community Service (Kenya), Royal College of Surgeons in Ireland (Ireland), Learning for All (Australia), UNICEF East Asia and Pacific Regional Office, and the Mvula Trust (Johannesburg).

3.4 Previous work by organizations in Nepal

3.4.1 International Buddhist Society- Global Resources Institute

International Buddhist Society (IBS), based in Lumbini in the Terai Region of Nepal, has implemented a health-focused program since 1993 in the Rupendehi District in Nepal, which includes a free health clinic and a Community Health and Sanitation Program (in collaboration with Himalayan Exchange) in 17 villages. The purpose of the program is to provide health education, literacy and support small scale community

sanitation schemes. As a part of this program, Dr. Peter Moulton from the Global Resources Institute helped implement the SODIS program in 1999.

Before its implementation, field studies were made in order to assess the feasibility of SODIS in Lumbini. Solar radiation measurements showed that during the month of April, the average total influx from 8:00 to 16:00 was 5,450Whr/m² (of all lights). With this amount of solar radiation, in order to accomplish a complete removal of *E. coli*, clear bottles exposed required six hours of direct sunlight during the peak period of sunlight during the day (i.e. 4,700Whr/m²). Due to the synergistic effect of solar radiation and temperature bottles on a blackened rack required three to four hours (i.e. 3,000 Whr/m²) and bottles in a solar reflector one hour or direct sunlight (i.e. 1,000 Whr/m²). However, data is not given about wavelength of light of radiation measured (Moulton, 1999).

Microbial indicators used for these tests, were total coliforms and *E. coli* through membrane filtration, and hydrogen sulfide producing bacteria, obtaining an 80% relationship in the results made with both tests. All microbial tests were tested within four hours after sample collection.

From its implementation during the first year, the program showed good reductions in the number of cases of diarrhea and amoebiasis in the nine villages that joined the program.

Observations of the actual situation of the program by the author of this thesis during the month of January 2003, and interaction with IBS and Dr. Mallik, director of the Health Clinic and Community Health and Sanitation Program, indicate that the SODIS program was stopped due to two reasons: 1) there was lack of plastic bottles (PET) in the region; 2) visits to the villages and talk with population suggested the labor that SODIS is hard for big families: taking out from eight to ten bottles of water every morning and putting them back in again every night is difficult and time-consuming..

3.4.2 ENPHO-EAWAG/SANDEC

Building on the work of MIT Nepal Water Project (see Section 3.5) in April 2002, the Environmental and Public Health Organization (ENPHO), in collaboration with the Federal Institute of Environmental Science and Technology (EAWAG/SANDEC) started a research project to assess the potential of SODIS in different climatic conditions of Nepal, as well to as compare different technical options (such as different types of bottles, supporting materials, paint, etc.), with an ultimate goal of providing guidelines on how to apply and promote SODIS in Nepal. During this study, the social aspects of the technology were also being examined.

Studies are being conducted in different locations in the three regions of Nepal: Terai, Hills and Mountains, using the Del Agua Field Kit (developed by the University of Surrey, Surrey, U.K.) to measure fecal coliforms as microbial indicators. The tests used are membrane filtration (MF).

- a) Terai: tests showed removal rates of fecal coliforms above 99.9%. However, few data was collected and further testing is under way.
- b) Hills: SODIS proved to be more effective in clear bottles, and was further enhanced by the use of reflective surfaces as support materials, resulting in removal rates of fecal coliforms above 99.9%.

- c) Mountains: tests showed strong influence of the weather. Removal rates at higher altitudes showed 100% efficiency of inactivation of fecal coliforms (Ghorepani 3,000m) even on fully cloudy and rainy days. However further study is needed to address the situation at other altitudes.

In general there seems to be a threshold of around 1500Whr/m² (of all spectral lights), above which the removal rate is above 92% for all cases and regions described above and above 99% for water treated exclusively with clear bottles.

Even though two days of exposure were more effective than one day, further studies are being made in order to assess effectiveness of one day exposure of clear bottles.

3.5 MIT M. Eng. Students in Nepal and Haiti

Since 2000, students from the Massachusetts Institute of Technology (MIT) Master of Engineering program have done research, collected, and analyzed data, and drawn interesting conclusions based on results and observations from different variables under study. While these thesis results have not been as widely published, they represent important information based on developing countries field data.

The general purpose of these MIT Master in Engineering studies has been to bring water quality solutions to developing countries, especially Nepal, Haiti and Nicaragua. Each thesis is meant to be part of a larger effort involving collection of data for further studies or research, based on specific regional physical, social, economic and political characteristics. This in order to have a better understanding of the present situation of developing countries and some of the causes, effects and possible solutions to reduce the high number of waterborne disease cases in these places.

3.5.1 Amer Khayyat

Amer Khayyat was the first Master of Engineering (M. Eng) student to undertake solar disinfection research as part of his M. Eng thesis work. He addressed the need of a household level disinfection technique due to the lack of drinking quality water and/or the inefficiency with which municipal governments supply tap water, encouraging citizens to take contaminated surface water from rivers nearby.

His study examined different disinfection systems, including chlorination, UV, and solar radiation during the month of January 2001, in Kathmandu, Nepal.

The microbial indicators used during his studies were total coliform, *E.coli* and H₂S producing bacteria. Microbial tests used were the HACHTM Presence/Absence (P/A) test with MUG reagent for *E. coli*, and a HACHTM most probable number (MPN) test for the H₂S bacteria. The studies do not specify the reasons for choosing one test or microbial indicator over another⁴.

⁴ The reasons we assume are due to the ease of use, ease of technology transfer and low cost, as is the case of other Nepal Water Project Team studies.

Khayyat tested several bottles with different characteristics, such as material used, and paint used to enhance the synergistic effect of solar radiation and temperature.

Results showed that:

- a) The quality of water was increased with the use of a prior treatment, such as filtration, to remove turbidity.
- b) The highest temperature attained during experimentation was 26°C, where no synergistic effect with temperature and solar radiation was achieved (no difference between black half-painted bottles and non-painted bottles).
- c) Concentration of free residual chlorine decreased in bottles with chlorine exposed to the sun.

He addressed the need of support and follow up for the implementation of any kind of water disinfection system and emphasized the women motivators (like the ones working at IBS) as important participants in this labor.

He also mentioned the inconveniences of the technology, due to its reliance on regional, seasonal, monthly and daily climatic changes.

3.5.2 Megan Smith

Her M. Eng. research in Lumbini, Nepal, during January 2001 consisted mainly in assessing the effectiveness and acceptability of two household point-of-use water treatments: solar disinfection (SODIS) and a micro filtration unit (Coming CerCorCeramic filtration unit).

During the year of 2001, results were collected in two of the seasons of major concern in Nepal for the use of SODIS: the month of January, where the lowest radiation is received, and during the monsoon season, due to the presence of clouds that obstruct the solar radiation during the heavy but short duration showers⁵ (Smith, 2001).

Smith chose as microbial indicators: H₂S producing bacteria, total coliforms, and *E.Coli*. HACH™ Presence/Absence (P/A) tests were used for total coliforms and *E.Coli*. HACH™ most probable number test and a homemade P/A test developed by the International Research Development Center (IRDC) were used for H₂S producing bacterial. During the study, P/A tests were preferred based on their effectiveness, simplicity and low cost.

A simulation of the solar radiation in the day's peak five hours in different areas of Nepal throughout the year was obtained by Smith with a program developed by Peter Oates (see below) which was made initially to obtain data from Haiti's solar radiation for studies during that same period (see Section 3.5.3). With this program, solar radiation data of the Terai region revealed the feasible implementation of solar disinfection systems in certain times of the year, and the difficulty to meet the 500W/m² (all spectral lights) for 5 hours threshold reported by others (Oates, 2001; Khayyat, 2000; Wegelin et al, 1994; Wegelin et al, 1997; SANDEC, 2002b) during the months of December and January.

⁵ Data collected during the monsoon season was provided by Cathy Pham, doctoral student at Harvard School of Public Health (Smith, 2001)

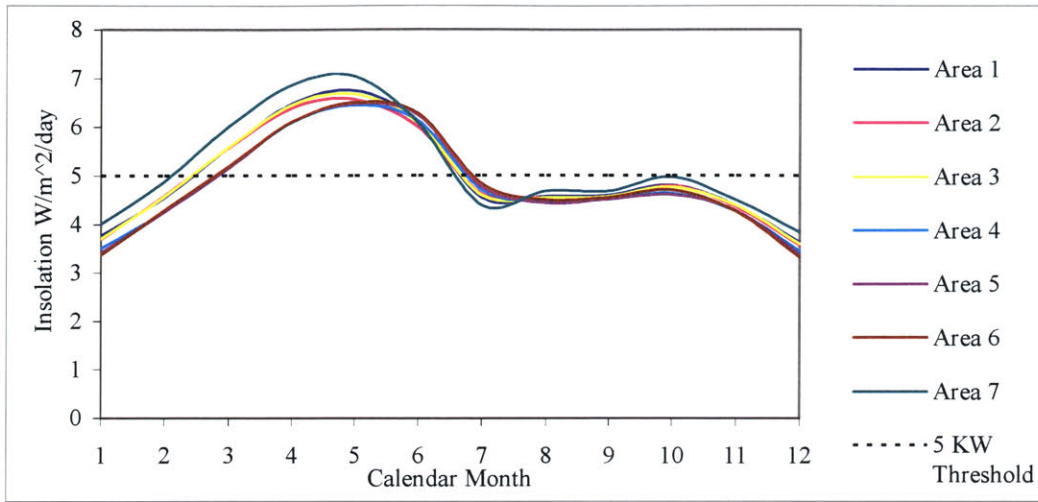

Figure 3.5 Average Insolation Simulated per Calendar Month Ten-Year Average in Indian Terai (south of Lumbini) SOURCE: Smith 2001

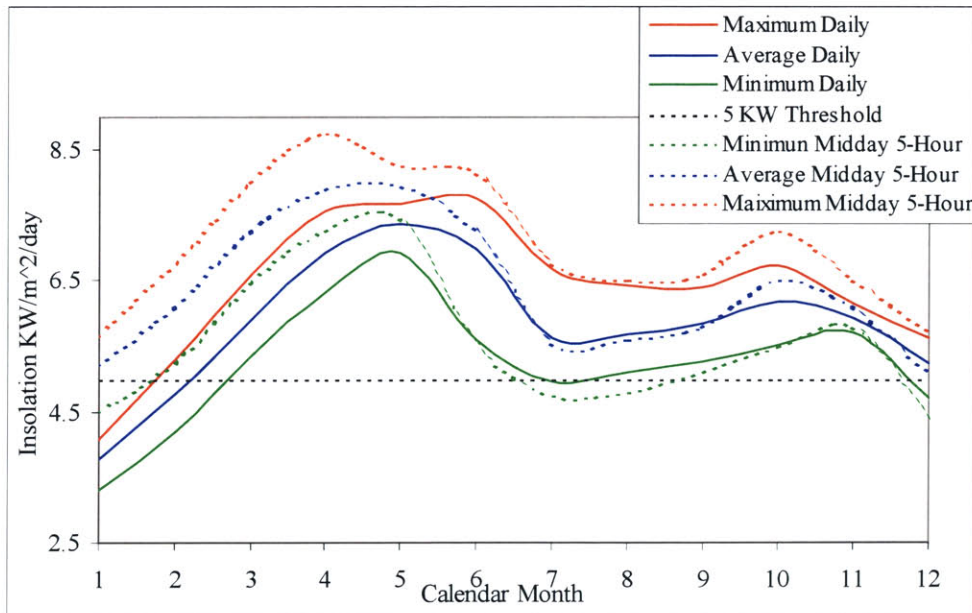

Figure 3.6 Maximum, Minimum, and Average Insolation Calculated for the Five-Midday Hours in Comparison to Maximum, Minimum and Average for the Full Day SOURCE: Smith 2001

Results from the data Smith (2001) collected during January 2001 showed that solar disinfection is a feasible solution for disinfection of polluted water. Smith's results showed one day of SODIS in the region of Lumbini during the month of January was 92% effective in inactivating 100% microbial indicators, and two days was 100%

effective. Pham's results showed similar data, where one day of SODIS was 54% effective, and two days were 100% effective.

Smith's study also showed correlations between the different tests. The best correlation was found between HACH total coliform and HACH *E.coli*, and between HACH H₂S and HACH *E.coli*. The worst correlation was found between HACH total coliform and HACH H₂S test. This data, however, depends on condition under which experiments were made and the sensitivity of the tests. Further studies under different conditions.

Smith's study informally addressed social acceptability. Talks with local people and organizations confirmed that SODIS was simple, easy and inexpensive. A very important part of Smith's study was the collaborative work with women motivators in charge of health promotion in the 17 villages of the IBS Lumbini Program, including household point-of-use techniques to treat contaminated water. Here a key factor, in terms of social acceptability and program sustainability, was the sharing of information between villagers, women motivators and Smith.

3.5.3 Peter Oates

The M. Eng. field work of Peter Oates was conducted during the month of January 2001 in Haiti. The main purpose of this study was to estimate the feasibility of the use of SODIS in Haiti, considering the different physical variations.

Oates developed a mathematical model to calculate average insolation for the mid-day peak five hours of sunshine based on NASA data for the maximum, average, and minimum available insolation for an average day each month in the region of study (in this case Haiti). As with Smith (2001), the validation of the model consisted in comparing simulated intensity values to measured intensities, but also to intensity values obtained from NASA Langley Atmospheric Sciences Data Center. The model showed 99% agreement with measured values and a 0.97 correlation with the NASA data. Results showed that solar radiation in Haiti is, on average, above the 500W/m² threshold for five hours throughout the year as suggested by others (Wegelin et al, 1994; Wegelin et al, 1997; SANDEC, 2002b, SANDEC,1998).

Results showed excellent agreement between simulated and measured average values, which gives a very powerful tool to address feasibility in other parts of the world where field data has not been collected.

The field research consisted of different tests in the presence of various sunshine intensities, bottle water temperatures and initial bacterial concentrations. Tests exposed to solar radiation for one day achieved total bacterial inactivation 52% of the times, while in all cases, two day exposure showed a complete inactivation. Oates' work agreed with Smith's and Pham's work in Nepal: two days exposure gave complete inactivation.

The microbial indicators chosen for these series of studies were total coliform, fecal producing bacteria, and *E. coli*, this last one based on recommendations made by different authors (Acra, *et al*, 1984; Wegelin, *et al*, 1994). With the purpose of answering the question of whether the target organisms are present or not, presence/absence tests were chosen. For total coliform and *E. coli* the test chosen was HACH's Presence/Absence Broth with bromcesol purple (BCP) for total coliform and methylumbelliferone glucuronide (MUG) for *E. Coli*. For fecal bacteria and H₂S producing bacteria, a P/A test was done with HACH PathoScreen™. From literature

review (Kasper *et al*, 1992; Martins *et al*, 1989; Grant and Ziel, 1996; Kromoredjo and Fujioka, 1991) Oates learned about the high correlation given for specific cases between H₂S producing bacteria and total coliform, and the advantages of this test in tropical weather (according to Kasper *et al*, 1992 incubation temperature can vary between 22 and 37°C). He concluded that the composite testing for total coliform, *E. coli*, and H₂S producing bacteria should reveal the efficacy of SODIS during his experiments in Haiti.

As a conclusion from his research, Oates pointed out that “the characteristics of the water to be treated, as well as the Haitian sunshine and warm climate showed suitable conditions for effective SODIS”.

3.5.4 Julie Parsons

Her M. Eng. study assessed the effectiveness of SODIS under conditions of lower temperatures and sunlight intensity. She tested two possible methods: a) enhancing the heating capacity of the bottle with black paint; b) increasing the amount of radiation with a reflector.

She created a mathematical model to predict the expected bottle water temperature under different exposure regimes, as a function of ambient air temperature, wind, and solar radiation. This study provides a tool for predicting the possible performance of SODIS when experimental data is lacking, based on the temperature that could be achieved in the bottle. Her results showed a good correlation between observed data and calculated data.

Collection of data was made during the month of January 2002 in three different places: Barasa and Dumay in Haiti, and Boston, Massachusetts.

Her studies showed that:

- In non-tropical climates, where temperature does not rise above 50°C in the water to obtain a synergistic effect with radiation, clear and half-painted bottles were more effective in the reduction of pathogen microorganisms than the completely painted ones.
- In tropical climates, temperature rise plays the most important role in the inactivation of microorganisms. Under these conditions, there did not seem to be a lot of difference between half painted and fully painted bottles.

The indicator organisms used for the study were *E. coli* and total coliforms. The culture media used was m-coli blue broth from Millipore Corp. using the membrane filtration technique.

IV. SOLAR DISINFECTION SYSTEMS

IV. SOLAR DISINFECTION SYSTEMS

4.1 SODIS

From the previous chapter, we were able to see the trends that have been taken towards the use and application of solar disinfection technologies. The system that has been most widely used and studied is the one known as SODIS, referred to in this thesis as batch solar disinfection. The success of this technology is basically due to its simplicity, practicability, and low cost. It is very important, before any application of SODIS is done, to check for the feasibility of meeting the threshold of $500\text{W}/\text{m}^2$ (all spectral light) for five hours (Wegelin, 1994; Wegelin, 1997; SANDEC, Solar, 2002, SANDEC, 1998).

4.1.1 Principle of SODIS

This technology consists of four basic steps: 1) Remove turbidity from water to be treated if it is above 30 NTUs; 2) Put the water to be treated in a characteristic vessel; 3) Aerate the water by vigorous shaking; 4) Expose the vessel to solar radiation for a certain designated amount of time.

Step1. *Assure turbidity below 30 NTU.* As we saw in Chapter 2, turbidity is an important variable when considering solar radiation as a disinfection system; it reduces the solar radiation penetration into the water to be treated. A simple turbidity test consists of putting letters of a certain size, or images, under the container full of water to be treated. As example, EAWAG/SANDEC proposed the following test:

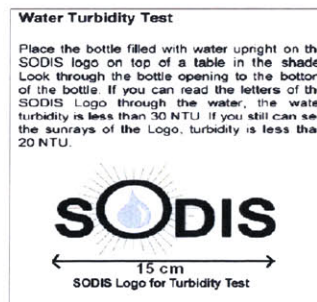

Figure 4.1
Turbidity test for 30 (threshold) and 20 NTUs

If the water to be treated has a turbidity above 30 NTUs, it is recommended to let the water settle or pass it through a filter. There is a wide range of different filter systems, but for practical purposes, turbidity could be lowered to 30 NTU by simply passing the water through a cloth.

Step 2. *Put the water to be treated in a characteristic vessel.* The material of the vessel has to be a good transmitter of light in the UV-A and visible range spectrum. The vessels most commonly found are either made of glass or plastic. How to choose one or the other depends on their characteristics and ease of use.

Different plastic materials are good transmitters of light in the UV-A and visible range. Plastic bottles found on the market are mainly PVC (Poly Vinyl Chloride) and

PET (Poly Ethylene Terephthalate). Both of these materials contain UV-stabilizers to protect them from oxidation and UV radiation. However, these stabilizers produce photoproducts that change the optical properties of the plastic materials, reducing over time the solar radiation penetration. Even though stabilizers and photoproducts generated on the outside surface of the bottle constitute a health risk, these photoproducts hardly ever pass through the bottle and into the water (SANDEC, 2002a, Wegelin et al, 2000). The possible compounds that could leach are acetaldehyde, terephthalic acid, dimethyl terephthalate and ethylene glycol. The first two are insoluble in water, so this reduces their chances of leaching; ethylene glycol might have a higher potential of leaching due to its relative solubility in water. Due to this concern, PET, with fewer additives, is recommended above PVC (in some countries like the United States, PVC is not allowed for POU treatment products). However, further studies should be made of this issue.

The transmission of UV-A radiation through glass depends mainly on the concentrations of iron oxide in the glass. Some of the advantages and disadvantages of the containers can be seen in the following table.

PET Bottles		Glass Bottles	
Advantages	Disadvantages	Advantages	Disadvantages
Low weight	Photoproducts	No scratches	Heavier
Relatively unbreakable	Limited heat resistance	No photoproducts	Easy to break
Cheap	More vulnerable to scratches and other aging effects	Resistance to heat	Expensier
Good UV-A transmittance			Usually lower UV-A transmittance

Table 4.1 Advantages and Disadvantages of PET and Glass Bottles

Other characteristics and recommendations made to increase the efficiency of SODIS are:

- Use bottles of one to two liters with diameters of less than 10 cm, in order to avoid efficiency loss due to limited solar penetration.
- Use vessels with screw caps (or other device to keep the vessel closed) to avoid recontamination.
- Paint half of the bottle with black paint (or put on a dark surface), in order to enhance temperature increase, or cover half of bottle with aluminum (or place on a reflective surface) to increase solar radiation.
- In the absence of bottles, use transparent clear plastic polyethylene bags. Even though they increase the exposure area, they are not as highly recommended as they are more difficult to handle and they break faster than plastic bottles.

Step 3. *Aerate the water by vigorous shaking.* This is for the purpose of increasing dissolved oxygen in the water to be treated, which creates elevated concentrations of reactive oxygen species that help inactivate the bacteria. This can be done by partially filling the bottle with the water to be treated, shaking it for a period of about 20 seconds,

and then filling it up to the top. In this last step, it is important to fill the bottle completely to avoid formation of air bubbles that can reduce the sunlight penetration.

Step 4. *Expose the vessel to solar radiation for a certain amount of time.* As we saw in previous chapters, the required exposure time for the total inactivation of the microorganism depends on different factors (location, time of the day, season, altitude, etc). The time required for complete inactivation can run from one hour (SANDEC, 2002), up to two days. However, in places where SODIS seems to be a viable option, two days of exposure under different conditions assures a 100% efficiency (Oates, 2001; SANDEC, 2002a; SANDEC, 2002b; Smith, 2001).

One of the recommendations for enhancing SODIS performance by increasing the solar radiation is to place the bottles heading north and with an angle of the latitude. This will allow the exposed bottles to receive the solar rays at the steepest possible angle and thus decrease the amount of radiation reflected.

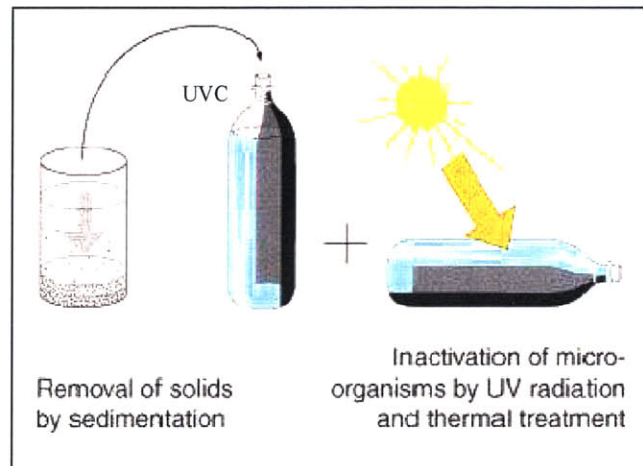

Figure 4.2 SODIS
Four Basic Steps

4.1.2 Important Variables

Even though it is a very simple system, there are certain variables that need to be taken into consideration when using SODIS as a disinfection system, as shown in Table 4.2:

Variable	Influences on Microbial Inactivation
Pathogen Microorganism	Pathogen microorganisms differ in sensitivity to inactivation heat and/or UV radiation
Water Vessel	Type, composition, volume, and depth influence water temperature, UV penetration, cleanability, and portability.
Sunlight; ambient temperature	Sunlight intensity, duration, and cloudiness influence water temperature and UV penetration.
Air pollution	Suspended particles in the atmosphere due to pollution absorb or scatter UV radiation
Vessel placement and orientation	Exposure to full sun avoiding shades throughout the day, placing the vessel facing north and with latitude inclination angle improve UV penetration.
Movement of vessel	Uniformity of water exposed to sunlight and minimization of differences in sunlight (UV) dosimetry reduces dead zones.
Temp. or Sunlight enhancement	Placing vessel in dark or reflective surfaces influence in water temperature and solar radiation.
Turbidity	Suspended solids or particles absorb or scatter UV radiation
Water aeration	Microbial inactivation increases with aeration if no residual bubbles reduce sunlight penetration.
Exposure time	Cumulative doses increase inactivation of microorganisms.

Table 4.2 Important SODIS Variables

4.1.3 Advantages and Disadvantages

Like most systems, or household level techniques for water disinfection, SODIS has its pros and cons. Table 4.3 synthesizes these as compared to other solar disinfection systems (see also Table 4.4 and 4.5).

Advantages	Disadvantages	Comments
Simple.	Requires long periods of time (sometimes up to two days) to assure 100% efficiency.	Need of further study for inactivation of certain pathogen microorganisms.
Low cost.	Limited to small volumes of water. Increased labor especially in big families where ten to fifteen PET bottles are required to meet minimum domestic drinking water needs.	Further study for application of indicator of intensity of solar radiation, in order to know when water is ready.
Widely known and studied.	PET bottles might not be available, and disposal of plastic bottles might represent an environmental problem.	Programs to distribute and collect PET bottles should be encouraged.
100% removal of pathogen microorganisms if applied correctly.	Inadequate education and training leads to misuse of system and decreases acceptance.	Education should always be an essential part of any POU system implementation.
	Need of periodic replacement of bottles due to aging and scratching, and cleaning to avoid formation of biofilms.	Need to know how long do bottles last.
	Hard work for housekeepers: laborious to take out bottles every morning and bring them back every night.	

Table 4.3 Advantages and Disadvantages of SODIS

4.2 Continuous Solar Disinfection System

Another approach to solar disinfection systems, which has not been as broadly studied, is continuous solar disinfection. As previously mentioned in Chapter 3, continuous solar

disinfection has already been tried in different studies made by Aftim Acra et al (1987), and Martin Wegelin et al (1994 and 1997) among others. After having tried the efficiency of solar disinfection in single batch reactors, continuous flow systems were tried applying the same fundamental principles. Even though good results with respect to microbial inactivation efficiency were observed, further studies in the development of these systems have not been made.

4.2.1 Principle of Continuous Solar Disinfection System

Continuous disinfection systems also combine the temperature effect and radiation to obtain a more efficient and quick disinfection. Usually the proposed design consists of a continuous reactor, or exposure reactor, where the water is exposed to direct solar radiation with a specific exposure area over a certain period of time, and in some cases a heat exchanger.

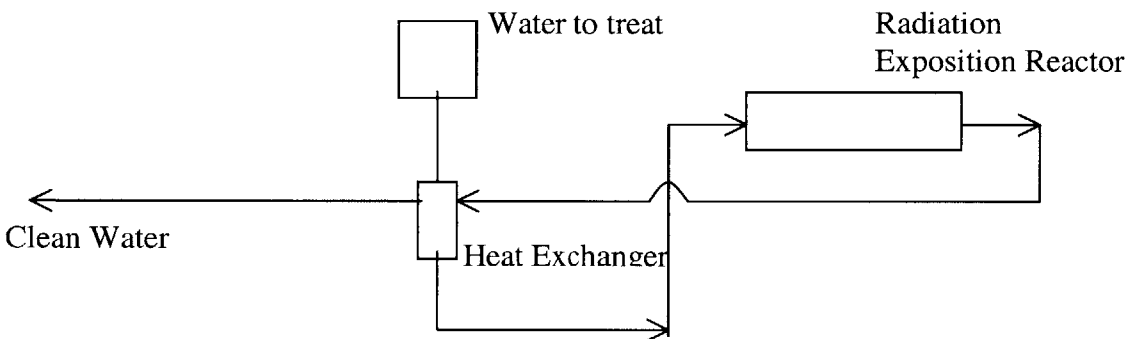

Figure 4.3 Solar Continuous Disinfection System

The important variable in this system is the residence time, or exposure time per unit volume, that water to be treated needs to receive in order to reach the solar radiation threshold of $500\text{W}/\text{m}^2$ (all spectral lights) for five hours (Wegelin et al, 1994; Wegelin et al, 1997; SANDEC, 2002b, SANDEC, 1998). One of the disadvantages of this system, but in common with SODIS, is that the tank reactor cannot be very deep, due to the fact that in about the first 10 cm, the solar radiation reduction is about 80% (Wegelin et al, 1997). Thus areas needed for single tank reactors are very large. The purpose of this approach is to be able to supply water at any given time continuously, without having to wait for two days to have safe drinking water. However this system has not been so popular due to its complexity and the high equipment costs (due to the necessity of more sophisticated equipment). Thus, it may not be affordable at the household economic level in most developing countries.

4.2.1 Advantages and Disadvantages

Table 4.4 summarizes the principal advantages and disadvantages of continuous solar disinfection:

Advantages	Disadvantages	Comments
Can treat larger volumes of water.	Requires accuracy in defining residence time of reactor.	Residence time can change depending on surrounding conditions.
Continuous flow of water. No need to wait for water since it is continuously flowing.	Need of more sophisticated and expensive equipment.	Training is needed to operate.
Can be used for bigger demands: institutions and communities.	Higher operation and maintenance costs.	Need of further study for biofilm formation.
No use of PET bottles, therefore no environmental or supply problem.	More difficult to understand. Operation requires a better understanding of the system due to its complexity.	Further study for application of indicator of intensity of solar radiation, in order to know if flow should be increased or decreased.
	Requires larger areas.	Large exposure areas are needed.
	Not for household level.	

Table 4.4 Advantages and Disadvantages of Continuous Solar Disinfection System

4.3 Semi-Continuous SODIS (SCSODIS)

Semi-Continuous SODIS is the prototype system proposed by the author. It is a manual intermittent system where the operator opens a valve during a certain period of daylight, and closes it during nighttime. The system consists of a reactor made out of multiple sets of two glued PET bottles placed in parallel, where the water to be treated passes through and is exposed to solar radiation. The water is fed to the system through a piping system connected to a source of microbial contaminated water. This system was conceived when trying to combine the advantages of SODIS and Continuous Solar Disinfection systems.

Some of the essential factors considered for the initial design of the system were:

- Environmental and site factors: time needed to obtain 500W/m² (all spectral lights) for five hours (Wegelin et al, 1994; Wegelin et al, 1997; SANDEC, 2002b, SANDEC, 1998) most of the time throughout the year.
- Characteristics of the water: type and concentration of pollutants (chemical or biological), flux to be treated.
- Quality of water needed in the outflow: WHO guidelines for absence of microbial contaminants and other hazardous chemicals.
- Social Feasibility
 - Is it easy to build, use and maintain?
 - Can it be locally operated and maintained?
 - Is it simple to understand and use?
 - What other water purification options are available?
- Economical Feasibility
 - How much are people willing to pay for treatment/disinfection systems?
 - What is the capital cost of the system?
 - Operation and maintenance cost?
- Selection of the optimal process and application only after extensive research and experimentation has been completed.

4.3.1 Principle of SCSODIS

Taking into account all of these considerations, SC-SODIS promises to create a more efficient and acceptable household treatment system. This system (Figure 4.4) consists of arranged PET bottles in parallel fixed together in such a way that water will pass through the bottles with a flow that will allow an exposure time of two days (exposure time recommended to obtain 0 CFU *E. coli* as suggested by WHO (1997)) through each one of the bottles. This system can work by gravity, placed on the roof of the houses where polluted water with turbidity of less than 30 NTU will be fed. There will also be a valve that will be set to a certain flux to assure complete water disinfection; (see Figure 4.4), and a second valve to close the flow when system is not in use (i.e. during the night) and is controlled by the householders. As part of the overall system, there will be a need of a storage tank in order to be able to stow the water as it becomes purified. However, it is not recommended to have long storage times, since there is the possibility of microbial regrowth and recontamination. Thus a daily average consumption equal to the amount of water produced by the solar disinfection system is recommended. The system (Figure 4.5) requires the use of a holding tank on a roof or another high elevation spot that can be filled manually or by electric pump.

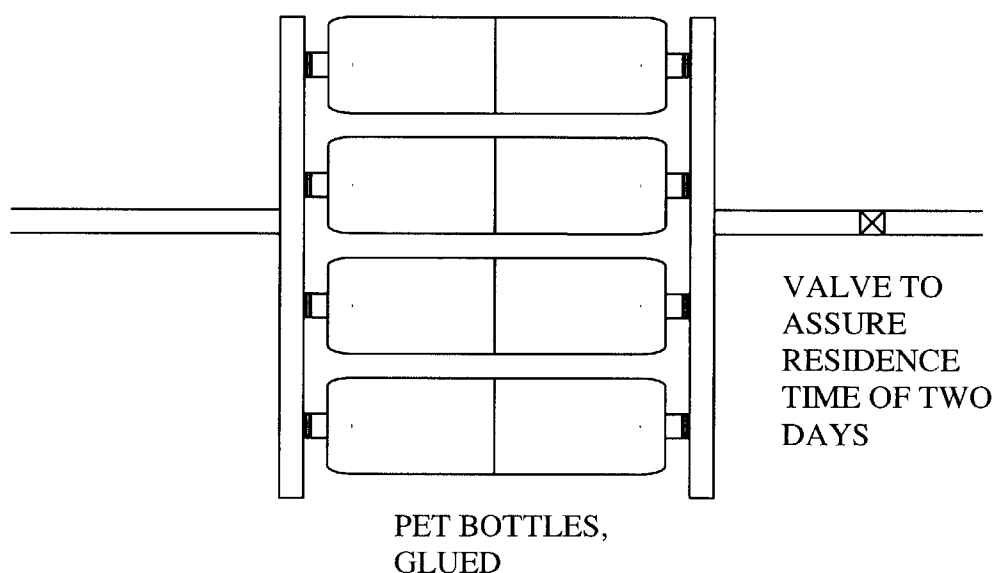

Figure 4.4 Bottles Arrangement for SC-SODIS

Within the system other variables can be studied, including the size of the containers, painting of the bottles half black, fully black or use of reflectance materials, different exposure or residence time, temperature effects, etc.. Due to the short time available for experimental work, only exposure or residence time variables have been studied (see Chapter 7).

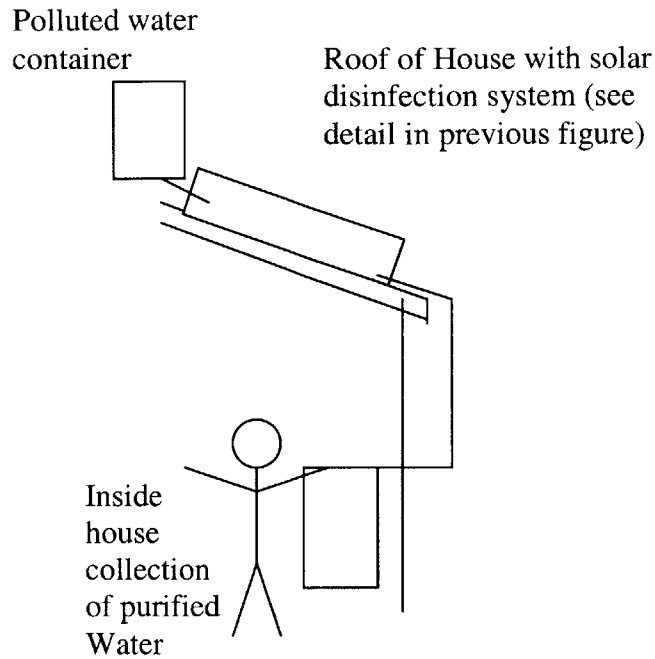

Figure 4.5 Semi-Continuous SODIS

4.3.2 Advantages and Disadvantages of SCSODIS

Advantages	Disadvantages	Comments
Simple.	Requires accuracy in defining residence time of reactor.	Further study for application of indicator of intensity of solar radiation, in order to know if flow should be increased or decreased.
Low cost.	Its still under study. Need of further research needs to be done.	Need of further study for biofilm formation.
Continuous availability of water.	Inadequate education and training leads to misuse of system and decreases acceptance.	Education should always be an essential part of any POU system implementation.
Diminishes use of PET bottles, reducing availability problem, as well as disposal of used bottles.	Process of building the system can be cumbersome.	Local manufacturer of the system could increase acceptability.
Diminishes laboriousness for housekeepers.		
Can treat larger volumes of water.		

Table 4.5 Advantages and Disadvantages of SCSODIS

SECTION II SEMI-CONTINUOUS SOLAR DISINFECTION SYSTEM

V. DESIGN CONSIDERATIONS

V. DESIGN CONSIDERATIONS

There are many design characteristics and criteria that need to be taken into account in order to provide a system that fulfills the characteristics required by solar disinfection systems, as well as the innovations to make SC-SODIS a sustainable technology.

5.1 Fluid Mechanics

A very important part of the prototype's design is knowing how the water behaves within the system. One of the major concerns when designing the prototype was how to consider the flow: turbulent, laminar or in between. Friction or pressure drops also had to be taken into consideration. To address some of these issues a system with higher flow rates (using 1.5 L bottles glued together) was chosen. We selected this system considering that the depth of the reactor for solar disinfection cannot be greater than 10cm (SANDEC, 2002b); therefore, only bottles below 1.5 L of capacity (with an average diameter of 8 cm) should be used. Thus the 1.5 L bottles are used as a representation of the limits of the system.

Some of the concerns addressed with the knowledge of the type of flow in the reactor are:

- a) Will the flow be uniform in the different individual reactors (two PET bottles glued together) ?

Based on the suggestion made by different authors, as described earlier, of two days of exposure, this value was given as residence time of the individual reactor. Assuming this residence time, we get:

- $\tau = 2$ days
- $Q(\text{per reactor} = 2 \text{ PET bottles glued together}) = V/\tau = 1.5 \times 10^{-3} \text{ m}^3/\text{day} = 1.5 \text{ l/day}$
- $A (\text{approx.}) = 5 \times 10^{-3} \text{ m}^2$
- Average velocity $v = Q/A = 3 \times 10^{-1} \text{ m/day} = 3.47 \times 10^{-6} \text{ m/s}$

With these flows and velocities, the pressure drop can be assumed to be zero (Crane, 1980; Madsen, 2002), and therefore, flow can be assumed to be uniform in all of the reactors.

As we described earlier, the flow we assumed for the calculations will be set constant in the valve that will only be accessible by a trained operator (see Figure 4.5).

- b) Will larger particles settle?

Settling velocities for very low solids concentrations (as expected with less than 30 NTU) are of less than 10^{-2} m/s (Metcalf and Eddy, 1991), which is still greater than $3.47 \times 10^{-6} \text{ m/s}$ that is our operational velocity. For this reason, we will expect most of the possible suspended solids to settle down as they pass through the system.

It is important to mention that because of the low turbidities of water required for the system, the size and amount of particles present in the inlet are expected to be low. However, in the case of high accumulation of particles, or formation of sludge, cleaning or replacing the system would be necessary. The

short time available for field experimentation did not allow to be more specific on this subject.

c) Diameter of tubes used.

After an informal market investigation in the U.S. and Nepal, that consisted of asking various knowledgeable people and visiting different hardware stores, ½" diameter Schedule 40⁶ pipes were used. In Lumbini, Nepal, this was the only pipe for which valves and fittings were found.

d) Spatial relationship of tubes and bottles.

The spatial relationship of the tubes and bottles was based on practicality. In order to be able to set up the system, this had to be relatively small to allow users to move it from place to place.

The prototype consists of four individual reactors. Although results suggest that the number of reactors can be scaled up accordingly to purified water needs, the prototype remains small due to space constraints (that are sometimes important in low income families). Enough space (10 cm) was given between individual reactors in order to prevent shading from neighboring reactors, while trying to keep the system small.

The spatial relationship within the bottles is in parallel due to the simplicity of the system and portability. Another option that could be studied is the bottles in series configuration. Each individual parallel reactor could be thought of as a small series system reactor, but a larger system could provide larger exposure areas, as the water would flow from one bottle into the other. However, one of the disadvantages of the series system would be the need of a structure to support the system. In the parallel system, the piping provides this support.

With all the characteristics mentioned above and after conducting a market study of the average sizes of the bottles, the SC-SODIS system was designed for four bottles glued bottom to bottom (individual reactors) and joined together at both ends to the PVC pipe system connected at the same time to a main distributing pipe at the inlet and outlet of the complete reaction unit. This spatial relationship of bottles and pipes maintains a relatively small structure (63 cm wide and 56 cm long for 2L bottles), as can be seen in Figure 5.1

⁶ Reference given for thickness for commercial pipes and fittings; for ½" the thickness of the wall of the pipe is 0.109 inches (Crane, 1980).

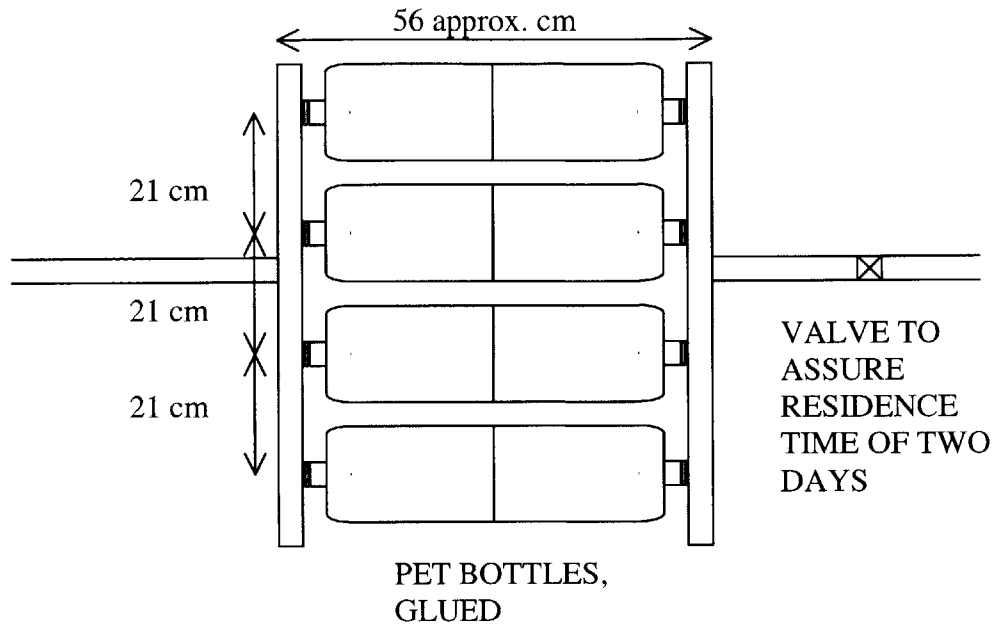

Figure 5.1 Measures of Spatial Relationship Between Pipes and PET Bottles

e) Inclination of system (roofs).

The proper inclination of the system (as we saw before in Chapter 3) increases the amount of solar radiation (UV-A light) that penetrates the water (reduces reflection, deflection and scattering). This inclination is dependant on the latitude of the place where the system will be set up so as to obtain solar radiation perpendicular to the reactors. Assuming that we are in the Northern Hemisphere, it is important to place the reactors facing south, in order to receive the sun light during the whole daylight time period, without shading.

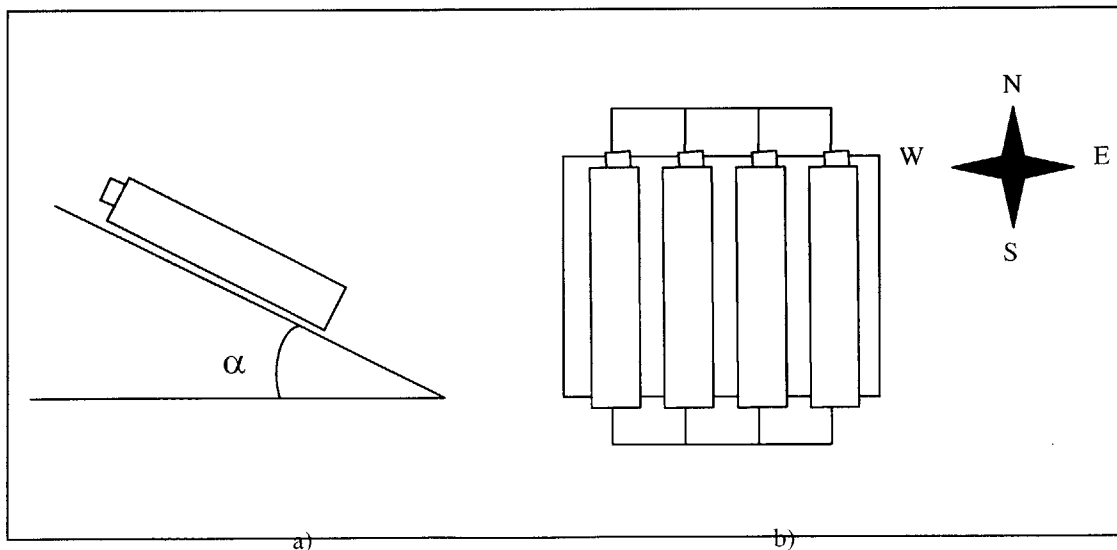

Figure 5.2 a) Inclination Angle and b) Coordinate Position of SC-SODIS

- f) Avoidance of dead flow areas or short circuiting within the system.

Another concern is the presence of dead flow areas or short circuiting within the system. Due to the low velocities used, the assumption of a laminar or plug flow might be correct.

Possible turbulences present in the system could be due to density gradients (due to temperature variations) along the reactors. This might have to be taken into consideration more seriously in tropical weather.

In our specific case, problems related to dead flow areas are not of big concern. If the water to be treated stays longer than expected in the system, it will receive a higher amount of solar radiation, and thus this would only increase the efficiency of the system. Nevertheless, knowing the fluids mechanics will help provide a better understanding of the system for future research and improvement of the system.

5.2 Construction Materials

5.2.1 PET Bottles

Based on the advantages that PET bottles addressed in the batch solar disinfection system (SODIS), we also decided to use PET bottles in the prototype system (SC-SODIS).

Based on an informal marketing study of different brands and sizes of PET bottles, the following characteristics are recommended. The bottles must:

- Be less than 1 ½ liters in volume (bottles with bigger volumes are too heavy and the walls are more flexible, which make these bottles more difficult to handle and glue).
- Have thick walls in order to be sturdy (especially in part where ends of bottles will meet and be glued)
- Have smooth surfaces (to avoid any shading and prevent or delay biofilm formation as much as possible)
- Be readily available in the community.

The following table show some examples of bottles tested in the United States during September trough December 2002:

Bottle	Good	Bad	Surface	Comments
Polar Springs 1/2 L		X	Corrugated	Too small and thin
Polar Springs 1 L	X		Corrugated	Good
Polar Springs 1 1/2 L	X		Corrugated	Good
Pepsi 2L		X	Smooth	Lack of support
Coca-Cola 2L		X	Smooth	Lack of support
Orange Juice			Smooth	Very thick, small volume
Aquafina 750 mL	X		Smooth	Small volume
Coca-Cola 750 mL			Smooth	Very thick, small volume

Table 5.1 Results From Bottle Survey in the U.S.

5.2.2 Glue

Another important aspect of this study was the correct type of glue to put together the two PET bottles that constitute the individual reactors. The characteristics the glues had to satisfy were:

- Be Non-reactive with water and solar radiation
- Be Non toxic
- Meet FDA (Food and Drug Administration), NSF (National Science Foundation) and USDA (U.S. Department of Agriculture) requirements (approvals for use in drinking water systems and/or contact with food)
- Glue PET⁷

Internet-based research consisted of looking at the characteristics of different brand names of glues (Liquid Nails, McMaster-Carr, 3M, Resin Technology Group, Super Glue, etc.). A more direct investigation consisted of buying different glues, reading their specifications and trying them. The following table show some of these results.

Glue	Component	Certification			Comment
		FDA	NSF	USDA	
Super Glue	cianoacrilate	-	-	-	not waterproof
PVC Cement	Toluene and Petroleum Destilate	-	-	-	hazardous
Epoxy (Fast acrylic for plastic)		-	-	-	not sealant, very thin
Superflex Clear RTV Adhesive Sealant	Silicone	-	-	-	good
Epoxy Putty		-	X	X	dark
Hot Melt Glue sticks	Silicone	X	X	X	melts some PET
DP-8005 Structural Plastic		-	-	-	UV and water resistant
DP-805 Acrylic		-	-	-	weather resistant
Polyurethane Adhesive/Sealants	Polyurethane	-	-	X	not translucent
Dow Corning and GE Silicones	Silicone	X	X	X	Not waterproof
Dow Corning and GE Silicones High-Temp	Silicone	X	X	X	Not waterproof
Food Grade Tubing	acrylated oleofin	X		X	UV and water resistant
Silicone II	Silicone	-	-	-	didn't glue PET

Table 5.2 Results from Glue Sampling in the U.S. (October-December 2002)

In Nepal, not much information about the glues was available. An adhesive sealant that turned out to be very effective was FERVICOL SR998. However, the characteristics of this product were not found, and thus a further study should be done to address if the product meets the criteria mentioned above.

⁷ PET proved to be a difficult material that can only be glued with very specific glues

5.2.3 Pipes

Based on observations of use of PVC pipes in drinking water systems, the availability, the wide international market of this type of material and low cost, PVC was chosen to be the pipes' material for the system⁸.

5.3 Operation and Maintenance Procedures

Important aspects needing to be taken into consideration for the effectiveness of any system are the operation and maintenance procedures. As addressed earlier, a good understanding of the system and how it works should go hand in hand with operation and maintenance activities.

The time that the contaminated water needs to be exposed to the solar radiation, therefore, setting a maximum aperture of the flow control valve, is a design consideration that needs to be well understood by the user(s). To set this aperture, special care has to be taken in knowing the maximum water head in the contaminated water holding tank and its hourly or seasonal changes, depending on the house's demand.

At start up of the system (i.e. when it is first used or after a long period without use) one needs to be sure that the system is completely clean and free of pathogenic bacteria. Bleaching the system's parts before use and/or exposing the PET bottles to the sun for a whole day before putting the system together is highly recommended. Once the system starts to run, the water coming out of the system the first two days should not be taken as drinking water as it has not received the designed exposure time (residence time) of two days.

Because peak solar radiation is usually at midday, it is recommended to run the system from 9 a.m. to 5 p.m. This will in addition allow the system to get some sunlight before and after operation (i.e. between 6 and 8 a.m. and 5 and 7 p.m. in average).

While it is important to develop a system that is easy to handle and use, the system should also be easy to operate and maintain. Even though the prototype system is intended to be static, aging, small scratches from outside influences, and biofouling may be some of the major problems that the system presents in the long run.

With this in mind, the system is designed in such a way that parts can be removed and replaced easily without affecting the system's efficiency⁶.

Unfortunately, time availability did not allow a further study on how often individual reactors and the piping system need to be cleaned and/or replaced. This suggests the need of a further study on the final prototype in order to address these issues.

5.4 Water Source Holding Tank

The SC-SODIS system is intended to be used in developing countries. With this in mind, the use of a holding tank as part of the system is required in order to get water to flow through the system by gravity without the need of any continuous pumping that might require the use of energy. The holding tank, at the same time, allows two options to the users: it can be filled manually, or by pumping water into it.

The reasons of the importance of the holding tank are:

⁸ See Appendix F for construction manual.

- a) The flow of the water through the system is function of the water height (head) in the holding tank.
- b) It can work as a sedimentation tank.
- c) It can work as a rain water collector system during the rainy season.

5.5 Aeration

There has been some discussion on whether the solar disinfection systems should or should not let air bubbles inside the PET bottles (E-Conference, 2002). Some authors have commented that oxygen in solar disinfection systems generates photo oxidative products that help in the inactivation of bacteria; others comment that air bubbles will reflect some of the solar radiation received and therefore diminish bacterial inactivation in the process (Acra et al, 1984; E-Conference, 2002, Sobsey, 2002). SC-SODIS has a special feature that might be affected by this discussion. As the water is entering continuously, it may carry a small amount of oxygen. Depending on the shape of the PET bottles chosen a bubble will form in their top end that might help with the photo oxidative process or diminish the sunlight received. Further studies should be made to this respect.

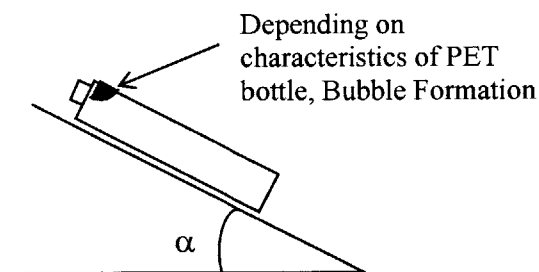

Figure 5.3 Bubble Formation in SC-SODIS

VI. METHODOLOGY

VI. METHODOLOGY

The study of feasibility of the Semi-Continuous SODIS (SC-SODIS) was divided mainly into three phases. The first phase consisted of work done during the Fall Semester at the Massachusetts Institute of Technology (M.I.T.), Cambridge, MA. The second phase entailed the field study in Lumbini, Nepal during the month of January of 2003. The third and final phase involved the analysis and conclusion of data collected in Nepal during the month of January 2003, development of new set of experiments during the month of April 2003, and writing up the thesis, including final analysis of results, conclusions and recommendations for further research and implementation of the system. In this chapter, a discussion of the most relevant methodologies used during these three phases is made.

6.1 Bacteriological Tests

As discussed in Chapter 2, there has been a relatively general consensus that *E. coli* and fecal coliforms are the types of microbial indicators that should be used for water quality testing in solar disinfection systems. However which type of bacteriological test should be used to detect it these indicators has turned into a worldwide discussion (E-Conference, 2002).

Nowadays there are various indicator tests available that can detect different organisms present in water. These are based on different mechanisms or procedures that consist mostly of creating a medium with specific conditions (temperature, selected nutrients, humidity, light, etc.) under which the microorganisms of interest would develop, and incubating for 24-48 hrs. These bacteriological test usually use a visible indicator to detect the target microorganism based on chemical changes that occur based on the given reactant present.

Some of the methods most widely used and discussed are P/A (presence/absence), MPN (Most Probable Number), MF (Membrane Filtration), and HPC (Heterotrophic Plate Count). The microbial indicators usually are H₂S producing bacteria, total coliforms and *E. coli*, and fecal coliforms. Other test include *Clostridium perfringens*, *Salmonella* and coliphages (viruses that accompany fecal coliforms like *E. coli* and prey on them), (www.hach.com, IRDC, 1993, 1995, Standard Methods, 1998).

Due to the ease of preparation and detection, and their apparent successful use in previous solar disinfection studies studies (Acra, 1984, 1987; Wegelin, 1994, 1997) and other previous M. Eng projects (Khayyat 2000; Oates, 2001; Smith, 2001; Parsons, 2002; Sullivan, 2002; Lukacs, 2002; etc.), the microbiological tests used for this project were H₂S producing bacteria presence/absence tests and the membrane filtration technique for *E.coli* and total coliforms.

a) *H₂S producing bacteria presence/absence test.*

This test, as its name indicates, is based on detecting the presence or absence of hydrogen sulfide produced by target organisms under specific conditions employed throughout the bacteriological test. The presence of H₂S is measured by its reaction with iron to form an insoluble, black precipitate of iron sulfide. Due to the low solubility of the iron sulfide, the test can detect small amounts of this precipitate.

Some of the bacteria identified under H₂S tests are: *Enterobacter*, *clostridia*, *Klebsiella*, *Escherichia*, *Salmonella*, *Acinetobacter*, *Aeromonas*, *Morganella*; and *Citrobacter*. Even though not all of these microorganisms are coliforms, they are found in the intestinal tracts of warm blooded animals (Sobsey & Pfaender, 2002; Low, 2002).

Because this test has been used over the last couple of decades, several modifications have been made to the original H₂S version reported by Manja *et al*, 1982, including changes in test medium, medium preparation (dried at elevated temperature, lyophilized, autoclaved only, etc.) sample volume (20 ml, 25 ml, 100 ml, etc.), paper use, paper type and paper size to which the medium is absorbed, incubation times and temperatures, etc. These characteristics, besides its variability, low cost (about US\$0.60 per test for the HACH H₂S (Low, 2002)) simplicity and ease of application to environmental methods, make the H₂S presence/absence test a good bacteriological test candidate, increasing its promotion and dissemination. Another advantage of this test is that it can be used for educational purposes, since it is relatively simple to perform, and the readings are very easy to do: if the bottle containing the sample turns black, we have H₂S producing bacteria; if it does not, then we do not. In addition the test detects any source of H₂S, including some non-fecal bacteria and sulfides that can be formed by abiotic processes. However, in all these cases, the risk is a false positive; i.e. to detect H₂S production by other means different than fecal contamination (Sobsey & Pfaender, 2002; Low, 2002)

However, there are also some disadvantages: 1) This test has been used in tropical climates where it has performed satisfactorily, but there is currently little data for colder climates (Sobsey & Pfaender, 2002); 2) As with other bacteriological tests, the presence of pathogenic enteric viruses or parasites is not detected.

In our specific case, because of the ease of transportation, the reactant chosen was the HACH™ PathoScreen Medium for a 20 ml sample. The procedure for this test consists of pouring the medium into a 20 ml marked bottle with 20 ml of the water to be tested, and incubating for 24-48 hrs at 35 °C. Even though this 20 ml test reduces the sensitivity of the system relative to 100ml tests, this technique was preferred due to its ease of application and transportation (for a more detailed description see HACH, 1997).



Figure 6.1 P/A Test Equipment and Supplies for H₂S Producing Bacteria

b) Membrane Filtration for E. coli and total coliforms, and fecal coliforms.

Even though these kind of tests are usually more expensive (US\$1.5 (Low, 2002)) they provide a quantitative result that allows a better determination of the relative health risk and therefore a better understanding or evaluation of a certain treatment or technology applied when using a disinfection system.

The procedure for Membrane Filtration (MF) consists of filtering 100ml of the water to be tested or diluted samples of the same water if necessary (i.e. if concentrations of microbial indicator are higher than 200cfu/100ml⁹), transferring the filter to a Petri dish with an absorbent patch where the broth has been previously inverted, covering it and turning it around (so that the absorbent patch is facing up) and incubating for 24-48 hours. The broth used will depend on the type of microbial indicator to be detected, and if the indicator organism is present, colonies that can be counted will appear on the membrane filter. The volume of the samples filtered are usually 100ml, thus giving good sensitivity. The data are reported as the number of colonies formed (CFU, colony-formation units) per 100 ml.

Assuming that bacteria are distributed randomly with a Poisson distribution (Standard Methods, 1998), the 95% confidence limits for colonies counted below 20CFU/100ml are tabulated below (Table 6.1). For values where the counted coliforms are more than 20CFU/ml, the 95% confidence, can be calculate with the following distribution (according to Standard Methods (1998)):

$$\text{Upper limit} = c + 2\sqrt{c}$$

$$\text{Lower limit} = c - 2\sqrt{c}$$

where c are the total coliform counts from the test.

⁹ Maximum number of colonies to count on membrane filter as recommended by Millipore (1992) and Standard Methods (1998)

Confidence Limits for Membrane Filter Coliform Results Using 100ml Sample		
No. of coliform	95% Confidence Limits	
	Lower	Upper
0	0	3.7
1	0.1	5.6
2	0.2	7.2
3	0.6	8.8
4	1	10.2
5	1.6	11.7
6	2.2	13.1
7	2.8	14.4
8	3.4	15.8
9	4	17.1
10	4.7	18.4
11	5.4	19.7
12	6.2	21
13	6.9	22.3
14	7.7	23.5
15	8.4	24.8
16	9.2	26
17	9.9	27.2
18	10.7	28.4
19	11.5	29.6
20	12.2	30.8

Table 6.1 Confidence Limits for MF under 20 CFU/100ml
SOURCE: Standard Methods, 1998

The technique used for the SC-SODIS study was MF for *E. coli* and total coliforms with HACH™ (www.hach.com) m-ColiBlue24 broth, which allows simultaneous colorimetric detection and enumeration of both total coliforms and *E. coli*. This technique uses a specific broth which make coliforms that are not *E. coli* turn red as they reduce TTC (2,3,5-triphenyltetrazolium chloride) and *E. coli* colonies turn blue due to a reaction between the enzyme beta-glucuronidase and BCIG (5-bromo-4-chloro-3-indolyl-beta-D-glucuronide) in the medium. This allows simple enumeration of each one of the microbial indicators used.

The technique consists of passing the sample of water through a gridded membrane filter, putting it in a Petri dish, adding the broth, and incubating for 24 hours at 35 +/- 5 °C¹⁰. After incubation, the number of colonies of each kind are counted¹¹.

Note: Neither of the bacteriological tests mentioned specifically look for pathogen bacteria, but instead use microbial indicators that would most commonly be present in the same environmental conditions.

¹⁰ Sensitivity specified for Millipore Single Chamber Incubator (Millipore, 1992)

¹¹ For fecal coliforms, the same procedure is used, the only difference is the broth used.



Figure 6.2 Membrane Filtration Test Equipment and Supplies for Total Coliforms and E.Coli/ Fecal Coliforms

6.3 Manipulation of samples and bacteriological tests

a) Sample collection.

For the membrane filtration test, the samples were collected into 100 ml sterilized Whirl-Pack® bags by Nasco with sodium thiosulfate tablets and closed immediately in order to avoid interferences. The bags were then placed into a thermocooler containing icepacks to avoid changes in the characteristics of the water sampled due to bacterial reproduction, where they were kept until the bacteriological test was made (within less than three hours). For the H₂S producing bacteria, 20 ml samples were directly collected in sterilized (boiled) 25 ml glass bottles and the same procedure was followed for storage until analysis¹².

b) Maintaining a Sterile Environment.

During the month of January in Lumbini, Bhikkhu Maitri, the director of International Buddhist Society (IBS) in addition to hosting members of our team, provided a room to the MIT Nepal Water Project Team to do all the necessary laboratory tests. This room was an essential working place, however, it did not fulfill all the characteristics of a 1st world laboratory. During the test, the surrounding environment was kept as sterile as possible (using only equipment that had been previously boiled, cleaning working bench with methanol before doing each test, washing hands, etc.); however, there were some possible contamination sources due to the constant presence of people, the presence of dust particles in the air, etc.

¹² In cases where samples were kept for further dilution (see Section 6.4), the time between the sampling and testing varied was up to one day.

In order to determine possible interferences in the procedures or the equipment used, blank tests were run every day. This did not guarantee that we would not have interferences, but if the blank tests came out blank (which they did) this told us that the interferences were small and did not affect our results.

c) Incubation

Two types of incubators were used, the first one was the Millipore Portable Single Chamber Field Incubator XX63 1K0 00 (see Figure 6.4), and the second one was a phase-change field incubator developed by Amy Smith from the Edgerton Center and the Department of Mechanical Engineering at MIT¹³. Because of the shape of the containers the Millipore Portable Field Incubator was used for the petri dishes for the MF tests. For the H₂S test, two phase-change incubators, with holes of the size of the 25mL flask, were used.

For both of the tests, the incubation temperature was 35°C (Standard Methods, 1998; Millipore, 1992).

The Millipore Portable Field Incubator ran on batteries at all times. This circumvented the problem of electricity shut downs (common in Lumbini). The incubator was kept closed as much as possible to assure a constant incubation temperature.

The phase-change incubators consist of tubes or other kinds of compartments (where the bacteriological tests are placed) surrounded by a chemical that undergoes a phase-change from solid to liquid when boiled, and which maintains itself at a constant temperature of 35°C for up to 24 hours if well insulated. During that time, the temperature of the incubator remains constant (as the chemical goes from liquid to solid state) allowing a proper incubation of bacteriological tests. While one phase-change incubator was used, a backup phase-change incubator was always available to place samples that needed further incubation after the 24 hours (i.e. when the chemical in the phase-change incubator had turned into a solid and needed to be boiled again).

¹³ This incubator has been tested by Amy Smith and previous M. Eng. Students in Nepal and Haiti



Figure 6.3 Millipore Portable Single Chamber Field Incubator XX63 1K0 00

d) Enumeration.

For the H₂S tests, the sample was taken out after 24 hours to check for the presence of iron sulfide, a black precipitate, indicating a positive result. If the result was negative (a clear, yellowish color), the sample was incubated for another 24 hours. These 24-hour negative samples were revisited again after 48 hours. If there was no presence of iron sulfide, then the test was considered negative (absence of H₂S producing bacteria); if iron sulfide was observed (even small amounts of precipitate), then the test was considered positive.

For the MF test, after 24 hours of incubation, the tests were taken out of the incubator, and (usually with the help of a lamp) the number of total spots, i.e. red and blue (total coliforms), and blue spots (*E.coli*) were counted on the membrane filter. The proposed technique by Millipore (1992) was used, where the counting of the “dots” or colonies formed is from top to bottom and left to right and right to left as one goes down the gridded membrane filter. Also, as recommended, if the number of colonies of interest counted exceeded 200, a dilution of the sample was made, and the test was done again¹⁴.

6.4 Water Quality Well Measurements

In order to characterize the quality of the water in the research area, address the need of a water treatment technology, continue with the work of previous M.Eng students as part of the MIT-Nepal Water Project, and to provide water quality data to locals and IBS, together with 2002-2003 MIT Nepal Water Project team member Melanie Pincus (see Pincus, 2003) and Dr. Ralph Coffman, water samples were taken in wells of 17 villages monitored by IBS, plus public and private wells from Buddahnagar, the village where IBS is located. Two samples were taken at each of the locations, one for the H₂S test (20ml), and another one for the membrane filtration test (100 ml). If these samples seemed very turbid, or nearby sources of fecal contamination were observed, extra volumes were taken in case of a need for extra dilutions for the membrane filtration test.

¹⁴ In some cases the volume of the sample taken did not provide for further dilutions.

In order to give information for further studies in the region, the collection of data from selected wells additionally consisted of:

- Turbidity measurement with HACH™ Pocket Turbiditymeter. The Turbiditymeter was calibrated with blank solutions almost every day for quality control. For every measurement, the sample cell was rinsed with the water to be tested two or three times, and then after letting the system come to a constant value, the measurement was recorded.



Figure 6.4 HACH™ Pocket Turbiditymeter and Cuvette

- Collection of GPS data. The measurements were taken at every well from which water was sampled. This GPS system (GPS III by Garmin), based on a satellite system, provided the geographical coordinates.
- Picture of well. At every location, pictures were taken trying to capture specific characteristics for later identification.

This information was collected in order to provide a more complete record of each one of the wells monitored.

Note: Because of low turbidity found in all well samples (<2.4 NTUs) at this project site, turbidity measurements were not taken into consideration to assess the feasibility of solar disinfection systems in this study, where water with turbidities below 30NTUs are acceptable.

6.5 Solar radiation measurements

Solar radiation intensity was measured using the Kipp and Zonen Solrad Kit system, model CM3/CC20. The kit contains a pyranometer that consists of a thermopile sensor, housing, a dome and a cable. The thermopile is coated with a black absorbent coating that absorbs the radiation and converts it to heat. The resultant energy flow is then converted to a quantifiable electric current by the thermopile. The pyranometer is covered with a protective glass dome that filters in radiation between 350-1500nm with a sensitivity of +/- 5%.

Hourly measurements were taken everyday, from 8a.m. until 6p.m. (January 6th to the 18th). This interval was based on the time of sunrise (7:30 a.m.) and sunset (6 p.m.) observed in Lumbini during the month of January 2003.

Two measurements were taken, one of the incident solar intensity, and a second one of the fluence, or the integrated incident solar radiation over the period of time elapsed over the course of a given day.

6.6 SC-SODIS monitoring

Previous studies (Acra et al, 1984; Acra et al, 1987; Khayyat 2000; Oates, 2001; Smith, 2001; Sobsey, 2002; Wegelin et al, 1994; Wegelin et al 1997) suggest that exposure time is one of the most influential variables in solar disinfection systems. Therefore for this system, removal efficiency at different flow was chosen to be the variable under study. This would also give an idea of how much water could be delivered daily in the prototype system (important variable for social acceptability).

In order to provide the necessary measurement of the SC-SODIS system, besides the prototype, single reactor SC-SODIS systems were used for monitoring purposes, each one with different flow rates. This allowed us to obtain more data in shorter time.

At the beginning of the experiments, the water used to feed the SC-SODIS system was water pumped up into water storage tanks on the roof of the IBS offices building. The characteristics of this water were:

- *E.coli* <200 CFU/100ml
- Turbidity between 14.0-37.5 NTU (if the water was taken near the walls or the bottom of the tank)
- Presence of algae

Unfortunately this water presented a lot of variability, mainly in *E. coli* concentrations (as detected from daily sample measurements). Later on, the source water had to be changed to 50:50 mixture of IBS roof water storage tank and near-by-pond water. This second source of water presented the following characteristics:

- *E.Coli* <<400 CFU/100ml
- Turbidity 31.1 NTU (approx).
- Presence of algae and other visible living organisms.

Samples were taken approximately every two hours from 9a.m. until 5p.m. simulating the 8 hours for which the system is recommended to be used. This consisted in measuring the volume of water that had passed through each one of the individual reactors collected in plastic bags (covered with black bags in order to avoid further influence of solar radiation once collected¹⁵; see Appendix C). 100ml samples from each SC-SODIS system were collected in Whirl-Pack® bags with sodium thiosulfate tablets, and placed immediately in a thermo cooler with ice packs, until analyzed within less than an hour for *E. coli* and total coliforms using the MColi-Blue broth membrane filtration methodology.

¹⁵ The temperature in Lumbini during the month of January 2003 was below 10°C, therefore, the influence of the possible increase of temperature due to the black cover bag, was not taken into consideration.

VII. RESULTS AND ANALYSIS

VII. RESULTS AND ANALYSIS

Most of the results presented here are based on the data collected during the month of January 2003 in Lumbini, Nepal. Because it was the intention of the author to assess SC-SODIS as to whether it is a sustainable system, the data collected can be divided into three different categories:

- 1) Technical Feasibility
 - a. Is a disinfection system needed?
 - b. Is solar disinfection (based on radiation data) applicable in the area?
 - c. Is this system able to inactivate or kill pathogen microorganisms effectively in order to reduce the incidence of waterborne diseases?
 - d. What is the minimum residence time necessary to obtain microbially safe drinking water?
 - e. How many liters of pure drinking water can be produced per day?
- 2) Social Feasibility
 - a. Is it easy to build, use and maintain?
 - b. Can it be locally operated and maintained?
 - c. How understandable is the system in order to be used adequately?
 - d. What other water purification options are there in the surrounding areas?
- 3) Economic Feasibility
 - a. How much are people willing to pay for a disinfection system?
 - b. How much does building of the system cost?
 - c. How much do operation and maintenance cost?

7.1 Technical feasibility

7.1.1 Tube well collection data

In order to address the use and need of the SC-SODIS, solar radiation data and water quality tests of different tube wells located in nearby villages were collected.

A total of 20 wells were sampled in some of the 17 villages monitored by IBS plus Buddahnagar (See Appendix B). The tables and the figure below shows a summary of the bacteriological tests.

No. wells	Positive H ₂ S	Positive MF	Negative H ₂ S	Negative MF
21	0	18	21	2

Table 7.1 Results from Well Monitoring in Lumbini During January 2003

Correlations	
Positives	0
Negatives	9.52%

Table 7.2 Correlation Between H₂S and MF Tests Based on Results from Well Monitoring in Lumbini During January 2003

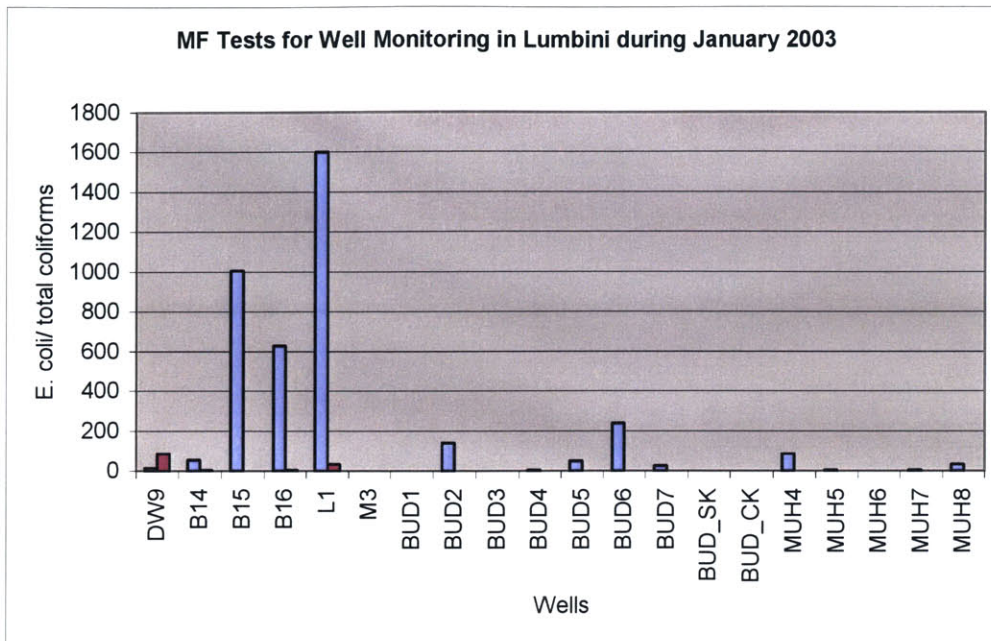

Figure 7.1 MF Results form 21 Wells in Lumbini during January 2003

Correlation between the H₂S tests and the membrane filtration tests was extremely poor, below 10% (See Tables 7.1 and 7.2) In the previous year, in the same area of study during the same season of the year, higher correlations were found by Sullivan (2002) and Lukacs (2002) (see Table 7.3). However, the temperatures under which the tests were taken were higher (5 to 25°C, according to Sullivan (2002)), while the weather during January 2003 in Lumbini was unusually cold with temperatures below 10°C most of the time. These results suggest that H₂S test might not be a feasible bacteriological test for relatively cold climates.

Level of Fecal Coliforms	Correlation
All Levels	0.57
0 CFU per 100 ml	0.82
1-4 CFU per 100ml	0.54
> 5 CFU per 100 ml	0.88
> 15 CFU per 100 ml	1.0

Table 7.3 Correlation between IDRC H₂S P/A Tests and Fecal Coliform MF Tests (Lumbini, Nepal, January 2002). SOURCE: Sullivan, 2002

Two possible causes for which the correlation between bacteriological tests were so low are: 1) The MF test can probably detect lower concentrations of bacteria than the H₂S test, as is indicated by the poor correlation observed by Sullivan (2002) at low bacterial levels. The concentrations present in the samples in the current study were in many cases below 4 CFU/100ml. 2) Due to the cold climate, the insulation provided for

the phase-change incubator to keep it at 35°C over the 24 hour period, might not have been sufficient (the MF tests were incubated in a different incubator as mentioned before).

Although presence of *E.coli* and total coliforms, was detected in the sampled wells, the concentrations were relatively small and do not seem to represent a big concern during this cold season of the year. However, local people assured us that these concentrations were much higher during the monsoon season, especially for *E.coli* (Mallik, 2003; Maitri, 2003).

7.1.2 Solar radiation

The data obtained during the month of January 2003, fall within the range simulated by Smith (2001) (see Chapter 3, Section 3.5.2) for the month of January. Figure 7.2 and Figure 7.3 show the hourly incidental solar radiation and average incidental solar radiation received from January 7th to January 18th in Lumbini, Nepal, respectively. The red line at 500 W/m² represents the threshold which should be exceeded for six hours for inactivation of microorganisms.

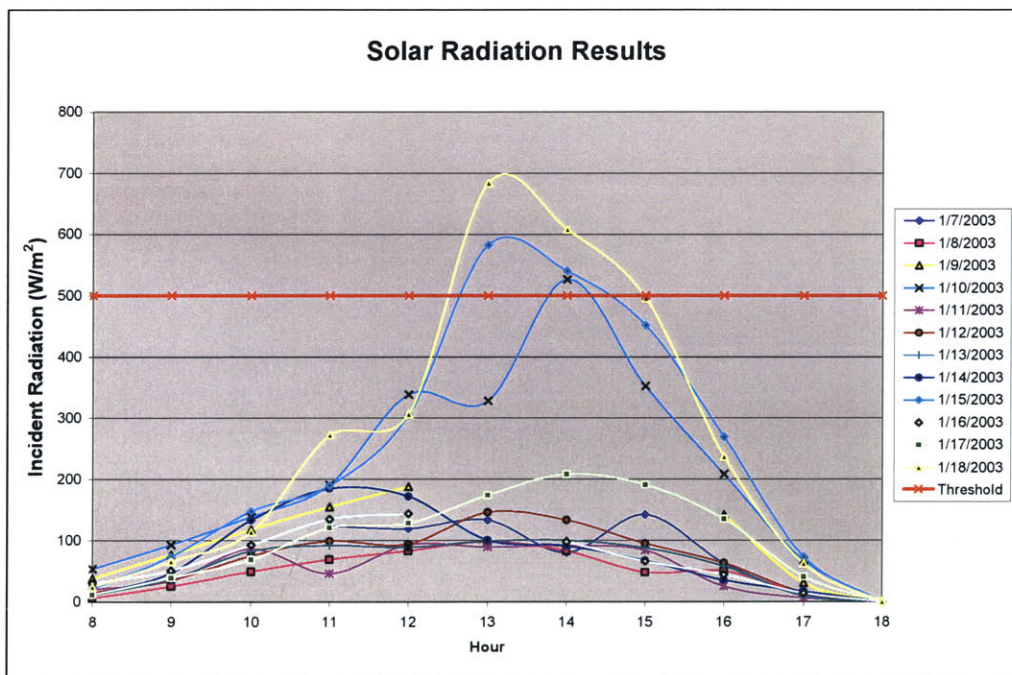

Figure 7.2 Hourly Incidental Solar Radiation Received in Lumbini during January 2003

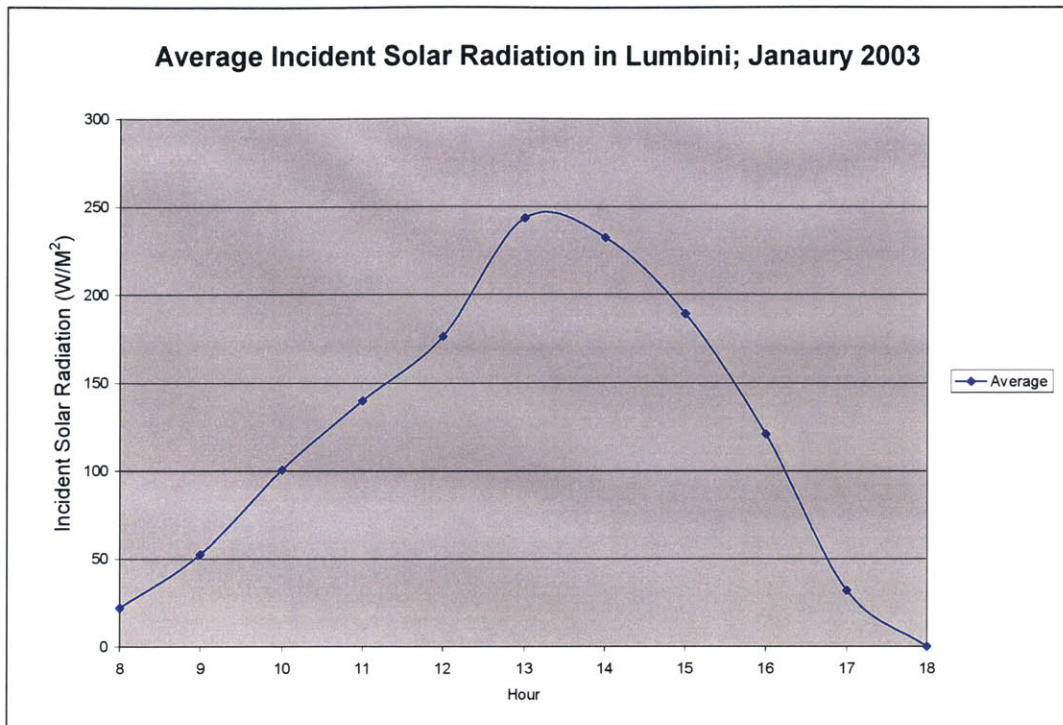

Figure 7.3 Average Incident Solar Radiation Received in Lumbini during January 2003

In order to equal a dose of $500\text{W}/\text{m}^2$ for five hours, the integrated solar radiation over a one or two day period needs to be above $2500\text{Whr}/\text{m}^2$. From the results obtained in Lumbini during January 2003, we can see that sometimes we were able to reach the $2500\text{Whr}/\text{m}^2$ threshold over the two days of exposure, and in two cases one day exposure passed this threshold (see table 7.3 and Figure 7.4). Looking at these data, the conditions did not seem to be as favorable as thought for SODIS during this time of the year; however, local people (Mallik, 2003; Maitri, 2003; Women Motivators, 2003; other people from villages) said that this year (i.e. 2003) the climate was not normal, it was strangely cold, and they usually do not get as many cloudy and foggy days in a row as observed during January 2003.

Day	Radiation Whr/m ²	Observations
1/6/2003	832	Cloudy
1/7/2003	891	Cloudy
1/8/2003	443	Very Cloudy (battery)
1/9/2003	1449	Cloudy and little sun at 16hrs
1/10/2003	2166	Very foggy morning, sunny afternoon
1/11/2003	544	Very foggy
1/12/2003	794	Foggy morning, cloudy afternoon
1/13/2003	695	Foggy and very cloudy
1/14/2003	813	Cloudy and foggy
1/15/2003	2559	Cloudy and sunny after 12hrs
1/16/2003	796	Very foggy anf cloudy
1/17/2003	1154	Cloudy and dim sun afternoon
1/18/2003	3150	Cloudy and sun after 13hrs
1/19/2003	523	(Half day) Very foggy and then sun

Table 7.4 Integrated Solar Radiation and Observations of Weather in Lumbini During January 2003

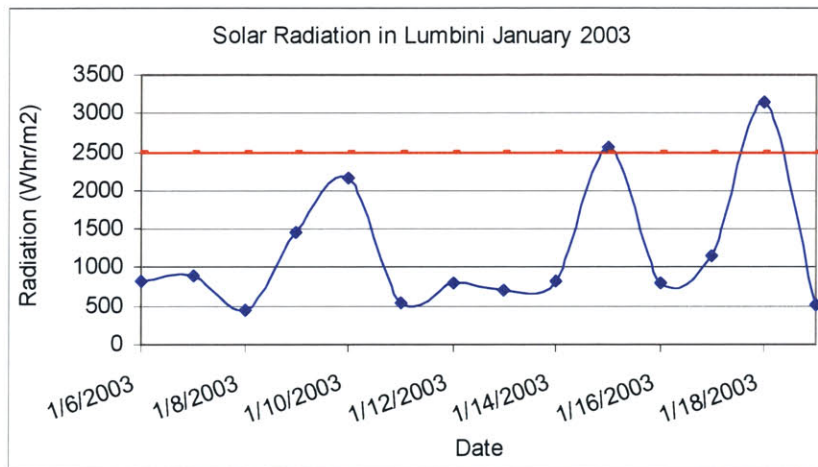

Figure 7.4 Integrated Solar Radiation in Lumbini During January 2003

ENPHO, our local partner located in Kathmandu, has done studies in other parts of Nepal to address the feasibility of solar disinfection systems. Data of integrated solar radiation at different altitudes was collected during 2002-2003. These studies suggest very high efficiencies of SODIS in three zones of Nepal: Terai, Hill and Himalayas (see Appendix C). As a part of that study, ENPHO-EAWAG study researchers took some measurements in the area of Lumbini during the month of January 2003. Even though their results have not yet been published, solar radiation data taken by ENPHO researchers was very similar to the data obtained by the author.

Due to the low temperatures observed during January 2003 in Lumbini, we know that synergistic effects of thermal inactivation together with UV inactivation in the SC-SODIS reactors would not have been considerable.

7.1.3 SC-SODIS System Data Collection

The following graphs show the removal efficiencies from the data collected in Lumbini during the month of January 2003, based on the number of *E. coli* going into the system, and the number coming out. Figure 7.5 shows *E. coli* removal efficiencies vs flowrates, while Figure 7.6 gives *E. coli* removal efficiencies vs equivalent days of exposure. “Equivalent days of exposure” is a comparison to residence time of the system, or number of days the water to be treated in the SC-SODIS is exposed to solar radiation if compared to solar disinfection batch system (SODIS).

Due to the variability of concentration of *E. coli* of the source water fed to the system, a tracer test study was made to determine the behavior of the water through the system (see Appendix E for a more detailed explanation), to better determine the removal efficiency of the SC-SODIS system at different flowrates and equivalent days of exposure.

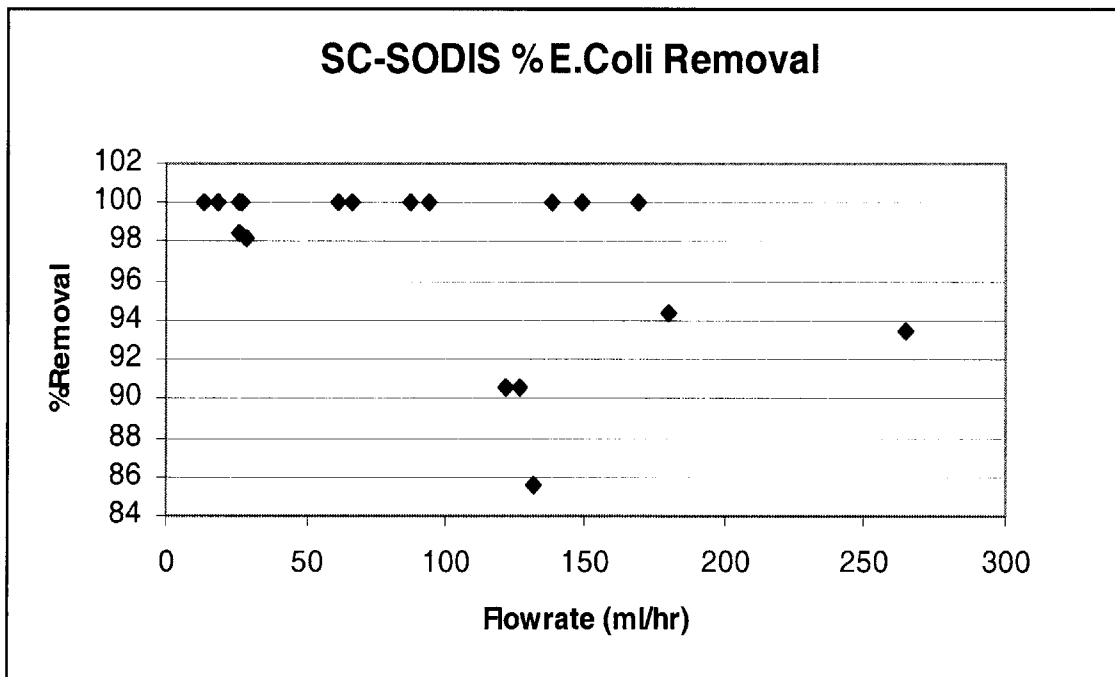

Figure 7.5 SC-SODIS % *E. Coli* Removal at Different Flowrates in Lumbini During January 2003

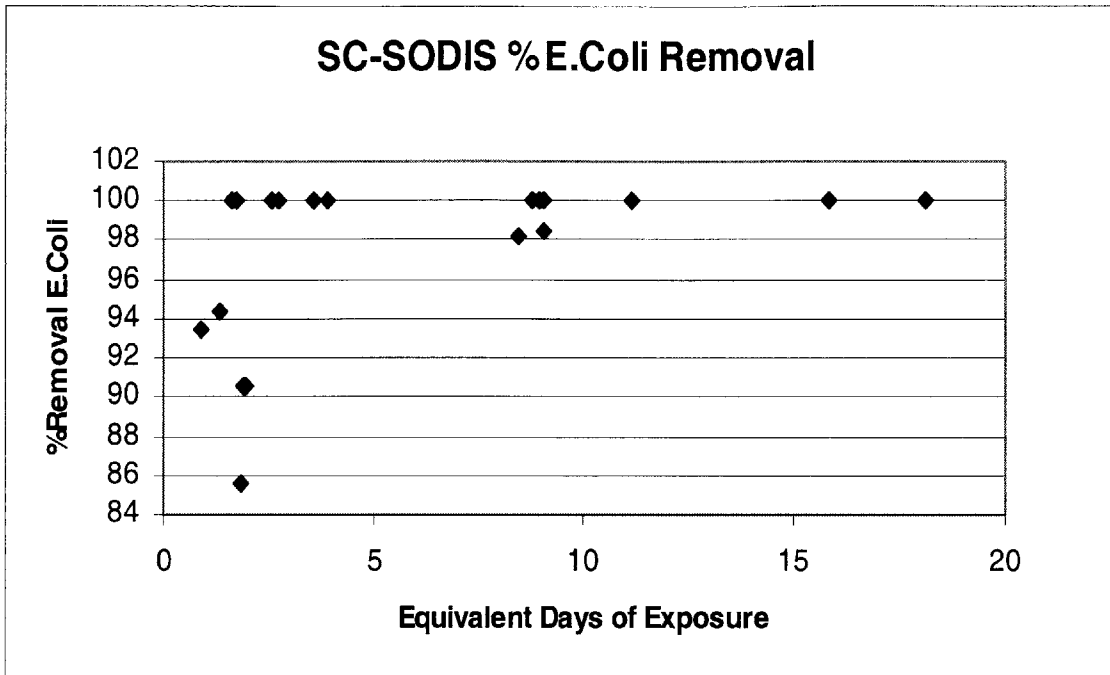

Figure 7.6 SC-SODIS %*E. coli* Removal with Different Equivalent Days of Exposure

From these two figures (Figure 7.5 and Figure 7.6) we are able to see a tendency of the system to increase its percentage removal efficiency as the flowrates decrease, and the equivalent days of exposure increase. However, it is important to remember, that these data are also affected by the amount of solar radiation received during the time exposed, which varied widely over time (see Figure 7.2 and Figure 7.4)¹⁶. The cold temperature might have also influenced the percentage removal of *E. coli* in the SC-SODIS system, as well as sedimentation due to the low flowrates, but we do not know to what extent. A more complete and specific research should study each one of these variables individually.

In order to have a correct interpretation of the figures presented above (Figure 7.5 and Figure 7.6) it is important to consider the detection limits of the microbial test used (MF) (see Table 6.1).

Even though the microbial indicator used for assessing the removal efficiency of SC-SODIS was *E. coli*, data obtained from microbiological tests for total coliform also give relevant information by which we can assess the feasibility of SC-SODIS:

- a) SC-SODIS did not seem to create a medium for microbial organisms to proliferate¹⁷. Microbial tests, except for two cases, show a decrease of total coliforms present in the water (see Figure 7.7). This amount was sometimes reduced to undetectable concentrations of total coliforms (<1CFU/100ml). Even though total coliform is not our microbial indicator, since it is present in natural environments (one of the reasons not to consider it to assess the efficiency), it provides information that would probably help future studies

¹⁶ Data obtain in Boston during the month of April 2003, corroborate this tendencies (see Appendix A)

¹⁷ Under the climate conditions present at the time of study.

(e.g. the study of possible biofilm formation based on suitable or inappropriate conditions inside reactors to proliferate).

- b) Due to the low flow rates of SC-SODIS, this system allows sedimentation of a considerable part of the suspended solids present in the water. Even though the source water to the system usually contained turbidity concentrations between 14 and 30 NTU, the water coming out was visibly less turbid than the source water¹⁸. This might also suggest that processes other than the sunlight exposure (such as sedimentation) might be removing bacteria.

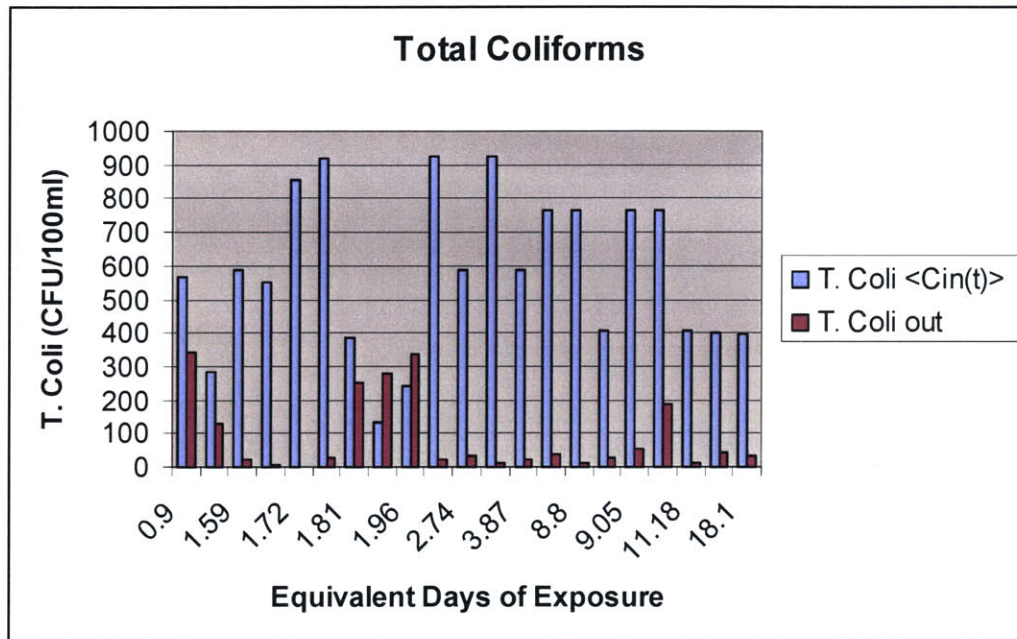

Figure 7.7 Total Coliforms in SC-SODIS

7.1.4 Liters of purified water produced daily

The current phase of study of the SC-SODIS, and the data collected, do not give enough information to assess a maximum flowrate at which the system still functions efficiently. This will also vary from region to region and within seasons. However, our results suggest that the system can be scaled up in parallel, either adding more individual reactors to the system, or else putting series of parallel reactors, as no apparent difference was observed in the performance of the SC-SODIS with one or four individual reactors (see Appendix A).

¹⁸From observations made by the author

7.2 Social Feasibility

The social feasibility assessment part of this overall SC-SODIS study was based on informal daily interaction with different people at different social, economic and educational levels in Lumbini and its surrounding during January 2003. This data include direct information from the local people, their real problems and concerns; people working on, local health and sanitation dissemination; and observations made by the author. These findings cannot be considered formal, since they are based on too small a sample¹⁹, and on informal methodology subject to the author's interpretations. A more complete and formal social assessment recommended for future studies should include health and sanitation, social, and educational surveys. Diarrhea horrea horea

7.2.1 SC-SODIS social feasibility facts

One of the first things we did after arriving at Lumbini, was to meet with the Women Motivators (Maya Panday, Asmita Chettri, Manorama Tripathi, Chandra Gupta, Susma Aryal, Santya Aryal) from the IBS-Himalayan Exchange and Cross Flow Nepal Trust Program and with Dr. Mallik, director of the Health Clinic and Community Health and Sanitation. In this first meeting, we learned how they work, what the major health problems are²⁰ and what concerns the population has, how is IBS involved in the monitoring of 17 nearby villages, which are the programs that have been implemented either by them or donors in Lumbini, and what are the causes they believe are the reasons of either success or failure of program or technology implementations. Specific information conveyed at that meeting that relates to SC-SODIS feasibility is:

- The SODIS program implemented by Peter Moulton in 1999 is in disuse.
- The failure of the SODIS program was due to:
 - i) lack of PET bottles
 - ii) laboriousness of taking out several PET bottles filled with water every day (Women Motivators, 2003).
 - iii) lack of constant monitoring of the program
 - iv) lack of inadequate training
 - v) lack of dissemination of information of how solar disinfection works, and the advantages and disadvantages.
- Presence of different animals (ducks, cattle, dogs, goats, etc.) all around the area limit solar disinfection systems to houses with roofs easily reachable (observations made during January 2003 in Lumbini).
- A system that would provide larger amounts of water constantly, that would not require as many PET bottles, and that would not require the laboriousness of carrying bottles around would be very acceptable (Mallik, 2003; Maitri, 2003; Women Motivators, 2003).

This information suggested that SC-SODIS might be more socially feasible than SODIS, and it could be implemented in this region, as it possesses the characteristics of

¹⁹ A representative sample should be estimated based on the interval of confidence wanted and the size of the population under study (Encyclopaedia Britannica Online, 2003)

²⁰ See Appendix G

the system described by Dr. Mallik and the Women Motivators. However, these facts also argue for the need of an implementation and follow-up program, one that includes a very good understanding of the principles of solar disinfection, as well as of the SC-SODIS system.

7.2.2 General findings

Among some of the valuable results obtained during the month of January 2003 in Lumbini are the data related to health and environmental behavior of local people. This information was obtained through daily communication with our local partner IBS (International Buddhist Society), specifically with Bhikkhu Maitri, director of IBS, Dr. Narendra Kumar Mallik, director of the Health Clinic and Community Health and Sanitation, and with Women Motivators from the IBS Himalaya Exchange Cross Flow Nepal Trust Program; informal talks with villagers; and general health and sanitation observations.

Previous studies conducted in Lumbini by Global Resources Institute (GRI) and the MIT-Nepal Water Project (Moulton, 1999; Smith, 2001; Lukacs, 2002; Sullivan, 2002) in collaboration with the International Buddhist Society, reveal the actual situation of Buddhanagar (name of village where IBS is located) and its surroundings. These studies showed the presence of indicator bacteria in public tube wells at different depths distributed in the 17 villages included in the IBS Health program (see Table 7.4) . These studies also suggest a close relationship between the introduction of water disinfection technologies and a reduction in the number of cases of waterborne diseases (Moulton, 1999; Smith, 2001; Sullivan, 2002). The MIT-Nepal Water Project also established a pilot study of a household chlorination plan as a first effort to monitor the implementation of chlorine as a household water disinfection technology, and its effect on the incidence of waterborne diseases (Sullivan, 2002).

Date	Test Method	# of Wells Tested	Percent Contaminated		
			Shallow	Deep	Open
April 1999	H ₂ S P/A & MF	42	72	78	100
January 2000	H ₂ S P/A (20ml)	27	64	62	-
January 2001	H ₂ S P/A (10ml)	32	46	33	100
January 2002	H ₂ S P/A (10ml) & MF	88	40	36	-

Table 7.5 Summary of Results of Lumbini Well Surveys, 1999-2002
(Sullivan, 2002)

Even though these previous studies provide information of the water situation in Lumbini, the off-the-record information given by the women motivators, Dr. Mallik, Bhikkhu Maitri, and other locals, and observations from surroundings and visits to different villages to do tube well samplings, gave the author an even wider view.

- Contamination in tube wells and waterborne disease incidence is even greater during the monsoon season (Maitri, 2003).
- In many of the villages cow dung is put on walls of houses to dry, providing a household source of fecal contamination of water that may

occur after collection from the well (observations made during January 2003 in Lumbini).

- In some villages there is a lack of information regarding the relationship between sources of microbial pollution, contaminated water, and diarrheal diseases (Women Motivators, 2003; observations made during January 2003 in Lumbini).

- There is a great need for technology, educational and economical support to overcome the actual situation besides the introduction of water disinfection technologies (Mallik, 2003; Maitri, 2003; Women Motivators, 2003; observations made during January 2003 in Lumbini).

- Kids are potential disseminators of information. Teaching health and water related issues in schools can be a good way to promote education through community participation (observations made during January 2003 in Lumbini).

- Follow up and continuous monitoring is essential in any study or project related to health, water quality control, and waterborne disease control (observations made during January 2003 in Lumbini).

Related to the last point, the presence of the Women Motivators that visit the different villages in the IBS program, as well as the quarterly (four times a year) health survey made by the International Buddhist Society are fundamental to any kind of study in the region.

7.3 Economical Feasibility

Based on the market study and the costs obtained for the different materials used to build the system, the table below show the cost of the SC-SODIS system²¹.

Quantity	Materials	Cost NRs
8	PET clear bottles	-----
2m	PVC pipe (2 m)	70
6	Tees	24
4	90° Elbows	12
1	Valve and adaptor	84
	Sand paper (or file*)	230
	Glue: FERVICOL (200ml)	90
	Total	510

\$U.S.1.00 = NRs 760

Note: The use of the flint instead of the sand paper increases the price by 230Rp, giving a total of 510Rp.

Table 7.6 Prices of Construction Materials for SC-SODIS in Nepal During January 2003

This table gives us a good idea of the economic feasibility of the system, where the price of the construction materials of the system is less than fifty cents of a dollar.

²¹ These dot not take into consideration the water source holding tank, since it is assumed to be already available in most of the places where the system would be implemented. If not, the price of a bucket or an alternative should be added to the total price.

VIII. CONCLUSIONS

VIII. CONCLUSIONS

The laboratory and field tests made in Lumbini during the month of January, were carried out to specifically address the feasibility of the Semi-Continuous Solar Disinfection System (SC-SODIS) as a sustainable technology as specified in the hypothesis. The tests and data collected to address the feasibility of SC-SODIS allow us to draw the following conclusions and discussion:

- a) Data collected from well surveys indicates the presence of *E. coli* in 86% of the wells sampled in the 17 villages monitored by IBS and Buddhanagar village, using the membrane filtration bacteriological test. However, the concentrations were very low, and bacterial contaminant may not represent a big threat to villagers during the cold month of January. Local people suggest that the number of contaminated wells, as well as the concentrations of bacteria, contamination increase dramatically during the monsoon season, implying the need for a water disinfection system technology.
- b) Data obtained from solar radiation did not reach the threshold of $500\text{W}/\text{m}^2$ for five hours in any of the days on which the author took measurements in Lumbini during January 2003. This suggests that solar disinfection is not a reliable disinfection technology for Lumbini in the month of January for exposure times of less than one day. The integrated solar radiation reached $2500\text{Wh}/\text{m}^2$ after two days, the exposure time recommended by others for cloudy conditions (EAWAG/SANDEC, 2002; Oates, 2001; Parsons, 2001), in only some cases.
- d) Removal efficiencies presented by SC-SODIS in the month of January in Lumbini suggests that even under bad weather, SC-SODIS can be a feasible solution if flow rates are adjusted to weather conditions (reduced flow rates increase removal efficiency). However, this should be considered preliminary result, and further studies should be made in order to assess the efficiency of the system under various conditions.
- e) Preliminary feedback from local people showed local people would prefer SC-SODIS to SODIS. SC-SODIS reduces laboriousness of solar disinfection and number of PET bottles required.
- f) SC-SODIS was constructed from 100% readily available materials found in Nepal (Lumbini and Butwal).
- g) Construction cost of the SC-SODIS system is below \$0.50 U. S. (NRs 300).

Based on these conclusions SC-SODIS can be preliminary considered a sustainable technology for the village of Lumbini, Nepal:

- SC-SODIS is technically simple.
- SC-SODIS is effective at microbial inactivation.
- SC-SODIS can be made from readily available materials (is accessible).

- Preliminary feedback from locals show SC-SODIS to be socio-culturally acceptable²².
- SC-SODIS is economically feasible.

However, it is important to understand that “sustainable” can differ in meaning, and even though SC-SODIS meets all of the criteria for the given definition, there are some disadvantages (see Chapter 4, Section 4.3.2) and limitations of the system that should be addressed, and that are not considered:

- Like other solar disinfection systems, SC-SODIS depends directly on the amount of incident solar radiation received at any given time, limiting the system to certain regions and times of year.
- For users without previous plumbing experience, building the SC-SODIS can be cumbersome activity.
- SC-SODIS is limited to availability of PET bottles (although to a lesser extent than the SODIS system currently used), glue that meets all the requirements specified in Chapter 5, Section 5.2.2, and PVC pipe tubes and fitting.

It is also important to remember that the development of the SC-SODIS is at an early stage, and there is still a lot to learn about this system and its limitations, as well as the influence of the different variables on which the removal efficiency might depend (e.g. formation of biofilms inside the walls of the individual reactors, leakage where PET bottles were glued, deterioration of PET bottles due to outdoor exposure, etc.)

Through this study, the author learned that a very important part of the design of the SC-SODIS was the interaction with and feedback from potential SC-SODIS users. Therefore, the definition of “sustainable” should be study-specific, depending area and population to be served. A truly sustainable technology should be the one that understands and meets the specific needs of a target population, taking into consideration social, cultural, economic, political, educational, and geographical aspects (such as climate and season of the year).

²² The last characteristic given in the definition of a sustainable system, is the potential for distribution. This was not part of the present study, however, in Chapter 9, some recommendations are given to assess this characteristic.

IX. RECOMMENDATIONS AND FURTHER STUDIES

IX. RECOMMENDATIONS AND FURTHER STUDIES

This section is intended to give information for future research based on the author's experience and learning throughout the investigation. Most of these recommendations go in parallel with difficulties found and suggestions for further studies.

9.1 Bacteriological tests

Difficulties:

- Correlation between H₂S producing bacteria tests and membrane filtration were very poor (0 for positives and 9.5 % for negatives) under the climatological conditions presented in Lumbini during January 2003.
- Lack of *E. coli* microbial indicator, or small concentrations of it in the water used for laboratory and field studies, reduced the amount of representative data gathered.

These results could be attributed to the cold temperatures of Lumbini during January 2003; however, special care should be taken when choosing a microbial indicator as well as a bacteriological test. Bibliographical research of the anticipated climate conditions should be made (for the H₂S test) together with an understanding of the microbial test effectiveness at that temperature.

Even though the author and colleague M. Eng student Melanie Pincus (2003), suggest that the climate was responsible for the difficulties described above, further studies should be made to corroborate these assumptions.

Based on the extremely different conditions present in the same region of study during the monsoon season, studies during the summer months should be encouraged. The data gathered during that time of the year would provide valuable information not only to assess the feasibility of SC-SODIS, but also to corroborate the increase of microbial contamination in drinking water, and the apparent failure of H₂S producing bacteria tests due to cold temperatures.

9.2 SC-SODIS system follow-up

Difficulties:

- The difficulty of communicating with local people, and the time required to get to know the area, made it difficult to find the right materials for building the SC-SODIS system.
- The limited time was not enough to address operation and maintenance of the system in the long run and under different climatologically conditions, and the different variables present: solar radiation, residence time, concentration of pollutants, cloudiness, temperature (ambient and inside system), etc.

In order to reduce the amount of time spent in looking for the materials, as well as the time spent in building the system, a local manufacturer that would provide part of the system, or the system already constructed, would help, not only to reduce the time spent,

but also to disseminate the technology. A local producer could be an NGO, or a private manufacturer.

More time should be spent (between 6 months and one year) in studying the different variables, the effectiveness under different climates, the replacement time of the PET bottles, and the cleaning of the system (in the short time under study, the system did not present any biofouling problems; however, other studies have suggested the formation of biofilms in the wall of the individual reactors or PET bottles (SANDEC, 2002b)).

Further implementations of the system should be encouraged. The potential study of different flow rates at different climate conditions of temperature and solar radiation would give extra advantages not only to SC-SODIS, but to all solar disinfection technologies. The use of indicators such as WAPI and what the author calls the “color beads” could be explored.

The reusable water pasteurization indicator (WAPI) consists of a clear plastic tube partially filled with a soybean wax that melts at about 70°C. The wax is placed on top of a tube on the water to be heated. When the temperature is reached, the wax melts and falls, giving a visual indicator.

UV Detecting Beads (beads made of a photosensitive material) (Teacher Source, 2003), when kept in the dark, are white; however, when exposed to solar radiation, they change into different colors (see Figure 9.1). The disadvantage of these beads is that as soon as they detect direct solar radiation, they change into full color, not being able to detect different levels of incident solar radiation. However, the potential use of photosensitive materials, could be made part of a future study.



Figure 9.1 Color Beads a) Without solar radiation;
b) With Solar Radiation

9.3 Socio-Educational Issues

Difficulties:

- Showing the need of a technology or disinfection system when target population do not associate diarrhea and other diseases with impurities or pathogen microorganisms in water.
- Communication with users in order to understand their main needs.

The implementation of a system or program should come together with health and sanitation awareness and understanding of the current situation. As has been noted in many previous studies (EWAG/SANDEC, 2002; Sobsey, 2002), the introduction of any

water treatment technology or program needs to take into consideration the participation of the community in order for it to be successful. Added to this, the implementation must have follow up and continuous monitoring in order to work. As addressed by other authors (EWAG/SANDEC, 2002; Lukacs, 2002; Sobsey, 2002; Sullivan 2002), the relative failure of many programs is due to the inefficiency of application of a certain procedure, deficient understanding of operational procedures of a system, and lack or discontinuation of use and maintenance of implemented systems.

The current work of IBS is a step forward in this direction, where monitoring by Women Motivators in the different villages has helped to change some of the past behaviors. I believe the success of this program is mainly due to the close relationship between villagers and Women Motivators, as well as the constant visits of the Women Motivators to the villages. Nevertheless, further implementation of an educational program could be added to the current one.

9.4 Final Recommendations

There have been great advances in the development of technologies related to diminishing the number of deaths of millions of people due to waterborne diseases. However, it is important to understand that the problem cannot be solved only from the technical side; there are other important aspects that are related to this problem, such as the cultural, social, economic, educational, and political characteristics of a given area of study, and it therefore the entire problem has to be seen from a holistic point of view. Also in the definition of a holistic approach, it should be understood that the collaboration of all the participants and stakeholders (i.e. NGOs, Governments, institutes, universities, health care providers, population, householders, etc.) is essential. The specificity of this approach will provide a better understanding of the needs and the current health situation of the population under study, and a better understanding of the related problems at different levels, in order to provide more realistic and approachable long term solutions. The author believes that it is only through this that we will be able to provide long term solutions.

VI. REFERENCES

VI. REFERENCES

Acra, Aftim, et al. (1984) Solar Disinfection of Drinking Water and Oral Rehydration Solutions. Guideline for Household Applications in Developing Countries. Department of Environmental Health. American University of Beirut. Beirut.

Adams, Eric. (2003). Personal Communication.

Adams, E. (2003) Course notes for subject 1.77. "Water Quality Control" MIT Dept of Civil and Environmental Engineering. Spring 2003.

E-Conference on Solar Water Disinfection (SODIS), (2002). August. [http://www.sodis.ch/Files_e-conference/Summary2.doc]; [http://www.sodis.ch/Files_e-conference/Summary2.doc]

Encyclopedia Britannica On Line (2003) [<http://www.eb.com>].

ENPHO. (2000) Environmental and Public Health Organization a Decade. 10th Anniversary Souvenir. 2000.: ENPHO.

Fred Cote (2003). Personal Communication.

Garza Ruzafa, Alejandro, Marcos Ramos Arras (2002). Saneamiento de las aguas residuales y reuso de agua tratada. Tlaloc. April/June 2000. Pages.: 28-31.

HACH (1997). Water Analysis Handbook, 3rd Edition. Loveland, Colorado: HACH Company.

IRDC (1993). Indigenous Peoples Test the Water. IDRC Reports, April, 1993 and "Technology from the South in Canada's North" in *Health and the Environment -- a People-Centred Research Strategy*, Searching Series 3, 1992.)

IRDC (2003). You Can Drink The Water. IDRC Reports, October, 1995. [<http://www.idrc.ca>]

Jimenez Cisneros, Blanca Elena (2000). El tratamiento del agua residual. Tlaloc. April/June 2000. Pages.: 10-12.

Low, Chian Siong (2002). Appropriate Microbial Indicator Tests for Drinking Water in Developing Countries and Assessment of Ceramic Water Filters. Master's of Engineering Thesis. Massachusetts Institute of Technology. May, 2002.

Khayyat, A.M.,(2000). Study of the Point of Use Treatment Methods for the Disinfection of Drinking Water in Nepal. Master's of Engineering Thesis. Massachusetts Institute of Technology. May, 2000.

Lukacs, Heather. A.(2002). From Design to Implementation: Innovative Slow Sand Filtration for Use in Developing Countries. Master's of Engineering Thesis. Massachusetts Institute of Technology. May, 2002.

Lukacs, Heather. (2002). Personal Communication.

Madsen, Ole, S. (2002). Personal Communication.

Mallik, Narendra Kumar. (2003). Personal Communication.

Maitri, Bhikkhu. (2003). Personal Communication.

Martin Dominguez, Alejandra (2000). Desinfección del agua por radiación solar. Tlaloc. April/June 2000. Pages.: 20-22.

Martin Dominguez, Alejandra, et al. (1999) Desinfección del Agua por Radiación Solar. Instituto Mexicano de Tecnología del Agua. Mexico. 1999. Pages.: 51.

Metcalf and Eddy (1991). Wastewater Engineering Treatment, Disposal and Reuse. 3rd Edition. Metcalf & Eddy, Inc. McGraw Hill, Inc. Singapore.

Millipore Corporation (1992) Water Microbiology Laboratory and Field Procedures. Bedford, Massachusetts. [www.millipore.com]

Mc Cabe, Joseph. (2003) Solar Cookers International, Creating Healthy Communities. Solar Cooking International Volunteers. [www.edc-cu.org/pdf/Solar%20Cookers%20International.pdf]

Mc Master Carr Catalog (2003). [www.mcmaster.com]

Moench, Marcus; Caspari, Elisabeth; Dixit, Ajaya.(1999) Rethinking the Mosaic. Investigations into Local Water Management. U. S. A.

Moulton, Peter (1999) Water Survey and Testing in Lumbini, Nepal. Global Resources Institute, Eugene OR.

Munasinghe, M. (1990). Water supply policies and issues in developing countries. *Natural Resources Forum*. Butterworth & Co (publishers) Ltd.

National Geographic Online. [http://www.nationalgeographic.com/maps/]

Natural Resources Research Institute. (2003). University of Minnesota, Duluth. [www.wow.nrri.umn.edu].

Nepal Home Page (2003).[www.info-nepal.com/}

Oates, Peter M.(2001) Solar Disinfection for Point of Use water Treatment in Haiti. Master's of Engineering Thesis. Massachusetts Institute of Technology. May, 2001.

Pidilite (2003). Fevicol. [www.pidilite.com/fevicolr404.htm]

Pincus, Melanie (2003). Safe Household Drinking Water Via Biosand Filtration Pilot Project Evaluation and Feasibility Study of a Biosand Pitcher Filter. Master's of Engineering Thesis. Massachusetts Institute of Technology. May, 2003.

Reed, R.H.(1997) Solar inactivation of fecal bacteria in water: the critical role of oxygen. Letters in Applied Chemistry 1997, 24, 276-280.

Rittman, Bruce E.; McCarty, Perry L (2001). Environmental Biotechnology: Principles and Applications. McGraw Hill, Inc.. Singapore.

SANDEC (1998). SODIS News No.1, 1998.

SANDEC (1999). Sandec News No. 4. January 1999.

SANDEC(2002). Sandec News No.5. June 2002.

SANDEC (2002) Solar Water Disinfection. A guide for the application of SODIS. Swiss Federal Institute of Environmental Science and Technology. Department Water and Sanitation in Developing Countries. SANDEC Report No. 06/02

SANDEC(2003).Materials: Plastic vs Glass Bottle. Technical Note No. 2. [<http://www.sodis.ch/files/note2.pdf>]

SANDEC(2003).Materials: Bottles vs Bags. Technical Note No. 4. [<http://www.sodis.ch/files/note4.pdf>]

Sayada, Andrea Matles (1991). Nepal. A Country Studies. Federal Research Division Library of Congress. September 1991.

Smith, Megan (2001). Microbial Contamination and Removal from Drinking Water in the Terai Region in Nepal. Master's of Engineering Thesis. Massachusetts Institute of Technology. May, 2001.

Sobsey, Mark D. and Pfaender, Federick K. (2002). Evaluation of the H₂S Method for Detection of Fecal Contamination of Drinking Water. WHO

Sobsey, Mark D., et al. (2002). Managing Water in the Home: Accelerated Health Gains from Improved Water Supply. University of North Carolina. U.S.A. 2002.

Spiller, P., and W. Savedoff. (1999). Spiller Water: Institutional Commitment in the Provision of Water Services. Washington D.C.: Inter-American Development Bank.

Standard Methods for the Examination of Water and Wastewater. 20th Edition. (1998) Edited by Clesceri, L.S. Greenberg, A. E. and Eaton, A. D.

Sullivan, Hannah B. (2002) Household Water Chlorination for the Developing World: A Case Study in Lumbini, Nepal. Master's of Engineering Thesis. Massachusetts Institute of Technology. May, 2002.

Summer, B., *et al.* (1997) SODIS-an emerging water treatment process. J Water SRT - Aqua, No. 3

Teacher Source (2003). [<http://www.teachersource.com/catalog/index.html>]

Wegeling, M., Canonica S., Mechsner K., Fleischmann T., Pesaro F., Metzler A. (1994), Solar Disinfection: Scope of the Process and Analysis of Radiation Experiments. Water SRT-Aqua No.4

Wegelin, M.; Cononica, S.; *et al.* (2000). Does sunlight change the material and content of polyethylene therephthalate (PET) bottles?. Aqua. October, 2000.

WHO (1997). Guidelines for drinking-water quality. Vol. 3, Surveillance and control of community supplies. Geneva, WHO, 1997. (Second edition).

WHO (1998). Guidelines for drinking-water quality. Vol. 1, Recommendations. Geneva, WHO, 1993. (Second edition); and addendum to Vol. 1, 1998.

WHO/UNICEF Joint Monitoring Programme for Water Supply and Sanitation. Global water supply and sanitation assessment 2000 report.. (2000) World Health Organization and United Nations Children's Fund. U.S.A.

WHO. (2003) Global Water Supply and Sanitation Assessment 2000 Report. Annex A. [http://www.who.int/water_sanitation_health/Globassessment/globalAnnex.htm]

WHO (2003) Methodology for the Global Water Supply and Sanitation Assessment 2000. [www.who.int/water_sanitation_health/Globassessment/GlobalTOC.htm]

WHO/UNICEF Access to Improved Drinking Water Sources. WHO/UNICEF Joint Monitoring Programme for Water Supply and Sanitation Coverage Estimates 1980-2000

World Bank (2001). World Bank Data. [<http://devdata.worldbank.org/>]

World Bank. (1994). "Infrastructure: Achievements, challenges, and opportunities." In *World Development Report 1994: Infrastructure for Development*. Washington D.C.: The World Bank.

APPENDIX A

SC-SODIS and Solar Radiation Measurements

Lumbini and Boston

I. LUMBINI

Date	Total Flow(ml)	Flowrate(ml/hr)	Eq.Days Exposure τ (days)	Radiation(Whr/m ²)	E. Coli in CFU/100ml	T. Coli in CFU/100ml	Total E.Coli out (CFU/day)	E.Coli out CFU/100ml	Total T. Coli out CFU/day	Total Coli out CFU/100ml
1/8/2003					>>400	>>400				
1/9/2003										
1/10/2003	1104.00	138.00	1.72	2166.00	100.00	2200.00	0.00	0.00	56.00	5.07246377
1/11/2003	1104.00	138.00	1.72	544	0.00	300.00	0.00	0.00	28.00	2.53623188
1/12/2003				794						
1/13/2003	1101.00	169.38	1.73	695	0.00	46.00	0.00	0.00	321.36	29.1880109
1/13/2003	170.00	26.15	11.18	695	0.00	46.00	0.00	0.00	22.61	13.2993464
1/13/2003	120.00	18.46	15.83	695	0.00	46.00	0.00	0.00	48.72	40.6
1/14/2003	751.00	93.88	2.53	813	0.00	79.00	0.00	0.00	137.94	23.4991482
1/14/2003	212.50	26.56	8.94	813	0.00	79.00	0.00	0.00	56.65	26.6588235
1/14/2003	1195.00	149.38	1.59	813	0.00	79.00	0.00	0.00	164.30	20.3846154
1/15/2003	531.00	66.38	3.58	2559	0.00	28.00	0.00	0.00	50.90	9.58587571
1/15/2003	105.00	13.13	18.10	2559	0.00	28.00	0.00	0.00	31.16	29.6761905
1/15/2003	694.00	86.75	2.74	2559	0.00	28.00	0.00	0.00	219.48	31.6256484
1/16/2003	491.43	61.42	3.87	796.00	29.00	>>500	0.00	0.00	99.64	20.274505
1/16/2003	216.00	27.00	8.80	796.00	29.00	>>500	0.00	0.00	18.24	8.44444444
1/16/2003	225.14	28.14	8.44	796.00	29.00	>>500	13.75	6.11	83.64	37.1506618
1/17/2003	1011.00	126.38	1.88	1154.00	22.00	>>600	4.50	0.45	2799.22	276.87636
1/17/2003	210.00	26.25	9.05	1154.00	22.00	>>600	0.00	0.00	113.40	54
1/17/2003	1444.00	180.50	1.32	1154.00	22.00	>>600	13.60	0.94	1836.96	127.213296
1/18/2003	2120.00	265.00	0.90	3150.00	400.00	>>400	109.93	5.19	7244.99	341.744811
1/18/2003	210.00	26.25	9.05	3150.00	400.00	>>400	3.00	1.43	392.80	187.047619
1/18/2003	969.50	121.19	1.96	3150.00	400.00	>>400	11.05	1.14	3265.49	336.821558
1/18/2003	4197.00	131.16	1.81	3150.00	400.00	>>400	191.20	4.56	10572.52	251.9066

Weighted Average incoming concentration with Peclet of 32

Date	τ (days)	Interval (days)		Conc. According to date (E.Coli above, T.Coli below)												<Cin(t)>	Cout(t)
		0.4	1.9	1/8/2003	1/9/2003	1/10/2003	1/11/2003	1/12/2003	1/13/2003	1/14/2003	1/15/2003	1/16/2003	1/17/2003	1/18/2003			
				400	250	100	0	0	0	0	0	29	22	400			
				400	1300	2200	300	173	46	79	28	500	600	400			
1/10/2003	1.72	-1.032	1.548	332	42.5										374.5	0	
				332	221										553	5.07	
1/11/2003	1.72	-1.032	1.548	184	62.5	17	0								263.5	0	
				184	325	308	36								853	2.53	
1/13/2003	1.73	-1.0354223	1.55313351	4	50	25	0	0							79	0	
				4	260	550	75	29.41							918.41	29.2	
	11.18	-6.708	10.062	396	2.5										398.5	0	
				396	13										409	13.3	
	15.83	-9.498	14.247	400											400	0	
				400											400	40.6	
1/14/2003	2.53	-1.518	2.277	4	50	25	0	0	0						79	0	
				4	260	550	75	29.41	5.52						923.93	23.5	
	8.94	-5.364	8.046	396	2.5										398.5	0	
				396	13										409	26.65	
	1.59	-0.954	1.431		2.5	20	0	0	0	0					22.5	0	
					13	440	75	43.25	7.82	9.48					588.55	20.38	
1/15/2003	3.58	-2.148	3.222	4	50	25	0	0	0						79	0	
				4	260	550	75	29.41	5.52						923.93	9.6	
	18.1	-10.86	16.29	396											396	0	
				396											396	29.7	
	2.74	-1.644	2.466			20	0	0	0	0					20	0	
						440	75	51.9	10.12	9.48					586.5	31.62	
1/16/2003	3.87	-2.322	3.483		2.5	20	0	0	0	0	0				22.5	0	
					13	440	75	43.25	7.82	8.69	0.28				588.04	20.27	
	8.8	-5.28	7.92	284	32.5	12	0	0	0	0					328.5	0	
				284	169	264	27	13.84	3.22	3.95					765.01	8.44	
	8.44	-5.064	7.596	284	32.5	12	0	0	0	0					328.5	6.11	
				284	169	264	27	13.84	3.22	3.95					765.01	37.15	
1/17/2003	1.88	-1.128	1.692						0	0	0	4.35	0.44		4.79	0.45	
									6.9	27.65	9.8	75	12		131.35	276.87	
	9.05	-5.43	8.145	284	32.5	12	0	0	0	0					328.5	0	
				284	169	264	27	13.84	3.22	3.95					765.01	54	
	1.32	-0.792	1.188							0	0.6	15.95	0.22		16.77	0.94	
										3.16	0.6	275	6		284.76	127.21	
1/18/2003	0.9	-0.54	0.81									1.45	17.6	60	79.05	5.19	
												25	480	60	565	341.74	
	9.05	-5.43	8.145	184	75	13	0	0	0	0	0	1.16	0.22		89.38	1.43	
				184	390	286	36	15.57	3.68	5.53	1.4	20	6		764.18	187.04	
	1.96	-1.176	1.764							0	0	11.02	1.1		12.12	1.14	
										3.16	14.84	190	30		238	336.821	
	1.81	-1.086	1.629							0	0	17.4	2.2	12	31.6	4.56	
										5.53	5.6	300	60	12	383.13	251.9	

Tests from 01/07/2003

Source	T.Coli (CFU/100ml)	E.Coli (CFU/100ml)
IBS Bathroom	50	1
IBS Drinking water	>400	0
Well Chandraka;a	280	0

Tests from 01/08/2003

Source	T.Coli (CFU/100ml)	E.Coli (CFU/100ml)
IBS Drinking water	600	0
Tank for SODIS	>>400	>>400

Tests from 01/10/2003

Name	T. Coli (CFU/100ml)	E. Coli (CFU/100ml)	Exposure time	Observations	NTUs
IN	>>400	>>400			14
	2200	100		From dilution	
OUT					
SODIS 1	2	0	1 day		14
SODIS 2	5	0	1 day	with some algae	16.1
SODIS 3	8	0	1 day	with some algae	30.6
SODIS 4	9	0	1 day	algae and dirt	37.5
SODIS 5	10	0	1 day	wo/inclination	14
SCSODIS	56	0	2 day	wo/inclination	14.0?

Tests from 01/11/2003 and 01/12/2003

Name	T. Coli (CFU/100ml)	E. Coli (CFU/100ml)	Exposure time	Observations
IN	300	0		from dilution
OUT				
SODIS 1	46	0	threshold	w/inclination
SODIS 2	44	0	1 day	w/inclination
SODIS 3	9	0	threshold	wo/inclination
SODIS4	66	0	1 1/2 days	w/inclination
SODIS 5	21	0	2 days	w/inclination
SCSODIS	28	0	2 day	wo/inclination

Tests from 01/13/2003

Name	T. Coli (CFU/100ml)	E. Coli (CFU/100ml)	Volume (ml)	Flowrate (ml/hr)
IN	46	0		
12:30	Start at 10:30			
SCSODIS1	48	0	312	156
SCSODIS2	68	0	29	14.5
SCSODIS3	44	0	83	41.5
14:30				
SCSODIS1	30	0	138	69
SCSODIS2	22.22222222	0	13	6.5
SCSODIS3	38.46153846	0	13	6.5
18:30				
SCSODIS1	20	0	651	162.75
SCSODIS2	0	0	128	32
SCSODIS3	30	0	24	6

Tests from 01/14/2003

Name	T. Coli (CFU/100ml)	E. Coli (CFU/100ml)	Volume (ml)	Flowrate (ml/hr)
IN	79	0		
11:00	Start at 9:00			
SCSODIS1	25	0	268	134
SCSODIS2	20	0	71	35.5
SCSODIS3	33.33333333	0	6	3
13:00				
SCSODIS1	34	0	185	92.5
SCSODIS2		0		
SCSODIS3	24	0	503	251.5
15:00				
SCSODIS1		0	164	82
SCSODIS2		0		
SCSODIS3		0	389	194.5
17:00				
SCSODIS1	6	0	134	67
SCSODIS2	30	0	141.5	23.58333333
SCSODIS3	14	0	297	148.5
New Source				
POND	>>400	51		

NOTE: H2S test P/A from pond, incubated 1hr later from collection showed Absence

Tests from 01/16/2003

Name	T. Coli (CFU/100ml)	E. Coli (CFU/100ml)	Volume (ml)	Flowrate (ml/hr)
IN	>>500	29		
	NTU=31.1			
15:00	Start at 10:00			
SCSODIS1	3	0	295	59
SCSODIS2	6	0	137	27.4
SCSODIS3	7	0	152	30.4
17:00				
SCSODIS1	67*	0	135.5	67.75
SCSODIS2	16.7*	0	60	30
SCSODIS3	197.3*	13*	37	18.5

NOTE: Change source to bucket with mixture from pond and tank

* picked them up after more than one day; spots instead of red where orange

Tests from 01/15/2003

Name	T. Coli (CFU/100ml)	E. Coli (CFU/100ml)	Volume (ml)	Flowrate (ml/hr)
IN	28	0		
12:00	Start at 9:00			
SCSODIS1	7	0	230	76.66666667
SCSODIS2		0		0
SCSODIS3	44	0	421	140.3333333
15:00				
SCSODIS1	4	0	220	73.33333333
SCSODIS2	13.95*	0	80	26.66666667
SCSODIS3	5	0	225	75
17:00				
SCSODIS1	32.1*	0	81	40.5
SCSODIS2	80*	0	25	12.5
SCSODIS3	47.9*	0	48	24

* picked them up after more than one day; spots instead of red where orange

Tests from 01/17/2003

Name	T. Coli (CFU/100ml)	E. Coli (CFU/100ml)	Volume (ml)	Flowrate (ml/hr)
IN	>>600	22		
11:00	Start at 9:00			
SCSODIS1	76	0	263	131.5
SCSODIS2				0
SCSODIS3	43	2	338	169
13:00				
SCSODIS1	102	0	260	130
SCSODIS2		0		
SCSODIS3	103	0	390	195
15:00				
SCSODIS1	328	2	263	131.5
SCSODIS2				
SCSODIS3	98	0	374	187
17:00				
SCSODIS1	654	2	225	112.5
SCSODIS2	54	0	210	35
SCSODIS3	270	2	342	171

Tests from 01/18/2003

Name	T. Coli (CFU/100ml)	E. Coli (CFU/100ml)	Volume (ml)	Flowrate (ml/hr)
IN	>>600	>>400		
11:00	Start at 9:00			
SCSODIS1	503	6	793	396.5
SCSODIS2				
SCSODIS3	437	2	378.5	189.25
SCSODIS4	32	0	1510	755
13:00				
SCSODIS1	102	7	763	381.5
SCSODIS2	78	0	110	27.5
SCSODIS3	384	1	348	174
SCSODIS4	132	0	1200	600
15:00				
SCSODIS1	502	2	330	165
SCSODIS2				
SCSODIS3	120	0	140	70
SCSODIS4	70	2	245	122.5
17:00				
SCSODIS1	351	1	234	117
SCSODIS2	307	3	100	25
SCSODIS3	104	0	103	51.5
SCSODIS4	671	15	1242	621

Date	Observation	Total Radiation (Whr/m2)
1/6/2003	Cloudy all day	832

Date	Observation	Total Radiation (Whr/m2)
1/7/2003	C	891
Hour	Radiation	
	Actual W/m2	Elapsed Whr/m2
8		
11	124	359
12	119	451
13	133	578
14	80	674
15	142	759
16	63	858
17	12	888
18	0	891

Date	Observation	Total Radiation (Whr/m2)
1/8/2003	VC	443
Hour	Radiation	
	Actual W/m2	Elapsed Whr/m2
8	6	
9	25	17
10	49	53
11	69	116
12	83	200
13	98	275
14	83	349
15	48	373
16	50	407
17	14	440
18	0	443

Date	Observation	Total Radiation (Whr/m2)
1/9/2003	C/DS	1449
Hour	Radiation	
	Actual W/m2	Elapsed Whr/m2
8	38	
9	77	48
10	118	124
11	155	307
12	188	457
13		
14		
15		
16	142	1394
17	31	1439
18	0	1449

Date	Observation	Total Radiation (Whr/m2)
1/10/2003	VF/DS	2166
Hour	Radiation	
	Actual W/m2	Elapsed Whr/m2
8	54	
9	93	47
10	139	135
11	191	331
12	338	536
13	328	893
14	526	1274
15	352	1771
16	208	2044
17	68	2146
18	0	2166

Date	Observation	Total Radiation (Whr/m2)
1/11/2003	VF	544
Hour	Radiation	
	Actual W/m2	Elapsed Whr/m2
8	20	
9	34	21
10	86	84
11	46	145
12	93	220
13	89	291
14	91	387
15	84	473
16	25	525
17	6	542
18	0	544

Date	Observation	Total Radiation (Whr/m2)
1/12/2003	F/C	794
Hour	Radiation	
	Actual W/m2	Elapsed Whr/m2
8	15	
9	35	30
10	75	86
11	99	173
12	94	248
13	146	390
14	133	523
15	95	677
16	63	761
17	15	789
18	0	794

Date	Observation	Total Radiation (Whr/m ²)
1/13/2003	F and VC	695
Hour	Radiation	
	Actual W/m ²	Elapsed Whr/m ²
8	11	
9	37	29
10	83	95
11	92	162
12	89	276
13	99	376
14	100	517
15	88	595
16	58	661
17	9	693
18	0	695

Date	Observation	Total Radiation (Whr/m ²)
1/14/2003	C and F	813
Hour	Radiation	
	Actual W/m ²	Elapsed Whr/m ²
8	12	
9	47	22
10	133	124
11	185	266
12	172	408
13	101	570
14	91	670
15	67	769
16	35	881
17	17	839
18	0	813

Date	Observation	Total Radiation (Whr/m ²)
1/15/2003	C/S	2559
Hour	Radiation	
	Actual W/m ²	Elapsed Whr/m ²
8	22	
9	74	46
10	148	145
11	190	300
12	305	545
13	583	959
14	540	1520
15	452	1987
16	269	2364
17	74	2539
18	0	2559

Date	Observation	Total Radiation (Whr/m ²)
1/16/2003	VF and C	769
Hour	Radiation	
	Actual W/m ²	Elapsed Whr/m ²
8	30	
9	51	36
10	93	122
11	135	220
12	144	322
13		275
14	98	597
15	66	694
16	44	765
17	14	792
18	0	769

Date	Observation	Total Radiation (Whr/m ²)
1/17/2003	C/DS	1154
Hour	Radiation	
	Actual W/m ²	Elapsed Whr/m ²
8	12	
9	39	27
10	69	83
11	121	185
12	128	318
13	174	458
14	208	655
15	191	878
16	135	1041
17	41	1144
18	0	1154

Date	Observation	Total Radiation (Whr/m ²)
1/18/2003	C/S	3150
Hour	Radiation	
	Actual W/m ²	Elapsed Whr/m ²
8	24	
9	66	42
10	114	124
11	272	288
12	306	705
13	684	1240
14	608	1994
15	496	2539
16	237	2945
17	62	3121
18	0	3150

Date	Observation	Total Radiation (Whr/m ²)
1/19/2003	Until Noon	523

Day	Radiation W/hr/m2	Observations
1/6/2003	832	Cloudy
1/7/2003	891	Cloudy
1/8/2003	443	Very Cloudy (battery)
1/9/2003	1449	Cloudy and little sun at 16hrs
1/10/2003	2166	Very foggy morning, sunny afternoon
1/11/2003	544	Very foggy
1/12/2003	794	Foggy morning, cloudy afternoon
1/13/2003	695	Foggy and very cloudy
1/14/2003	813	Cloudy and foggy
1/15/2003	2559	Cloudy and sunny after 12hrs
1/16/2003	796	Very foggy anf cloudy
1/17/2003	1154	Cloudy and dim sun afternoon
1/18/2003	3150	Cloudy and sun after 13hrs
1/19/2003	523	(Half day) Very foggy and then sun

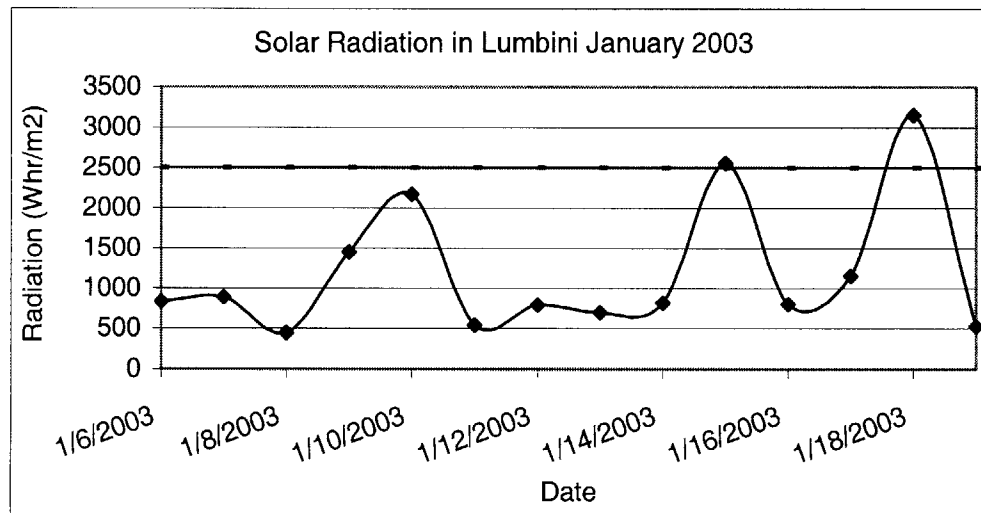

II. BOSTON

Tests from 04/19/2003

Name	T. Coli (CFU/100ml)	E. Coli (CFU/100ml)	T. Volume (ml)	Flowrate (ml/hr)	Radiation (W/m2)
8a.m.					504
IN	31	20			
12:00					
IN	442	442			804.00
SCSODIS1	0	0			
SCSODIS2	24	24			
15:30					690.00
IN	137	13			
SCSODIS1	0	0	1743	232.4	
SCSODIS2	17	0	3458	461.0666667	
SCSODIS2	17	0	3458	461.0666667	
SCSODIS2	17	0	3458	461.0666667	

Tests from 04/21/2003

Name	T. Coli (CFU/100ml)	E. Coli (CFU/100ml)	T. Volume (ml)	Flowrate (ml/hr)	Solar Radiation
9:30					661
IN	15	4			
12:00					
IN	13	6			876.00
SCSODIS1	0	0	1742	580.6666667	
SCSODIS2	2	2	3446	1148.666667	

NTU IN=2.6 NTU OUT=1.1

Tests from 04/20/2003

Name	T. Coli (CFU/100ml)	E. Coli (CFU/100ml)	T. Volume (ml)	Flowrate (ml/hr)	Radiation (W/m2)
8:30a.m.					583
IN	18	9			
15:30					637.00
IN	137	13			
SCSODIS1	1	0	3120	445.7142857	
SCSODIS2	11	9	6225	889.2857143	

Eq. Days of Exposure	E. Coli in	E. Coli Out	T. Coli in	T. Coli Out	%Removal
1.630522088	158.3333333	0	203.3333333	0	100
0.830537883	158.3333333	12	203.3333333	20.5	92.42105263
0.910897436	11	0	77.5	1	100
0.461365462	11	9	77.5	11	18.18181818
0.509830654	5	0	5	0	100
0.260446895	5	2	14	2	60

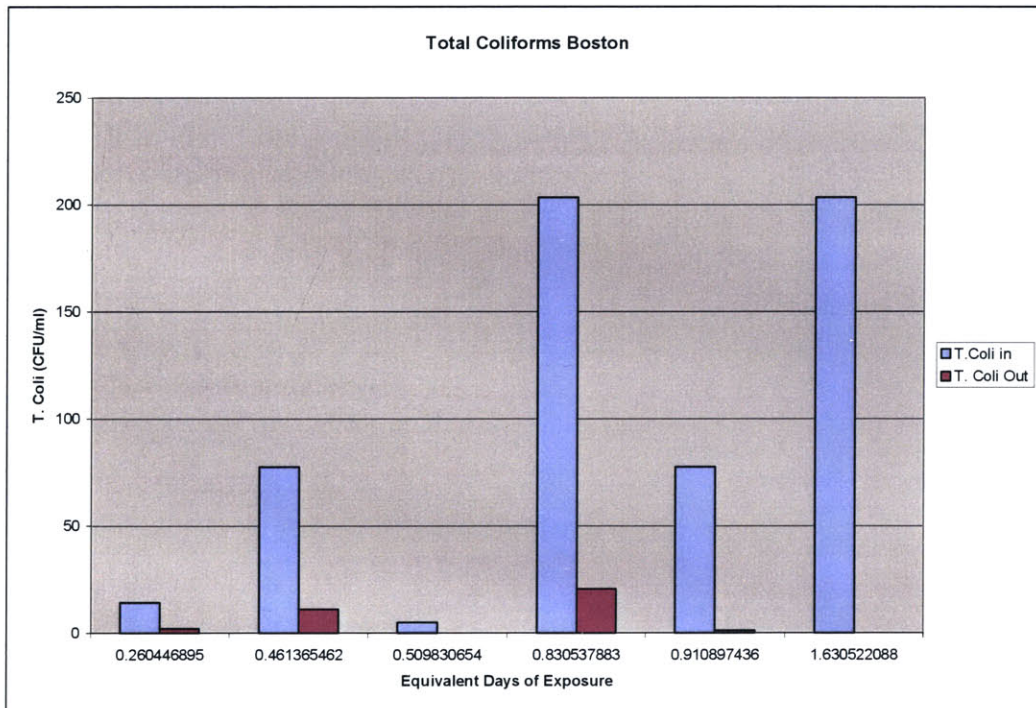
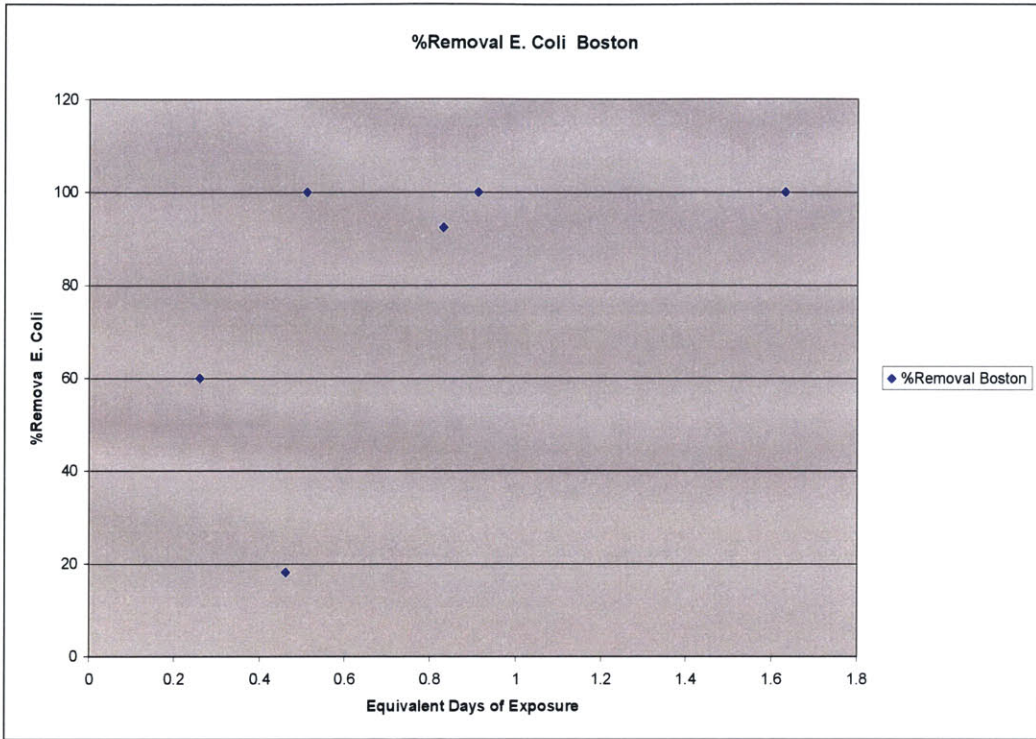

APPENDIX B

Well Measurements Lumbini, Nepal (January 2003)²³

²³ Tables provided by Pincus (2003)

Data from wells tested during January 2003 in Lumbini district						
Well	Turbidity (± 0.1 NTU)	HACH H ₂ S Tests ^a				
		Time Sampled	Time Incubated	Time Lag	Test Result 24 hrs	Test Result 48 hrs
DW9	--	14:27	1/7/2003 8:53	18:26	A	A
B14	0.0	--	--	--	--	--
B15	0.0	13:00	17:00	4:00	A	A
B16	0.2	--	--	--	--	--
L1	2.0	14:55	17:00	2:05	A	A
L2	--	--	--	--	--	--
M3	0.0	15:20	17:00	1:40	A	A
BUD1	0.0	15:10	16:20	1:10	A	A
BUD2	0.4	15:00	16:20	1:20	A	A
BUD3	1.5	14:45	16:20	1:35	A	A
BUD4	0.0	14:40	16:20	1:40	A	A
BUD5	0.0	14:30	16:20	1:50	A	A
BUD6	2.4	14:20	16:20	2:00	A	A
BUD7	1.9	14:10 14:10	16:20 16:20	2:10 2:10	A A	A A
BUD_SK	1.1	14:50	16:20	1:30	A	A
BUD_CK	0.0	--	--	--	--	--
MUH4	0.4	12:50	15:30	2:40	A	A
MUH5	2.4	12:40	15:30	2:50	A	A
MUH6	0.9	12:20	15:30	3:10	A	A
MUH7	0.7	--	--	--	--	--
MUH8	0.6	13:00	15:30	2:30	A	A

^aSample volumes are 20 mL.

^bUnless otherwise specified, sample volumes are 100 mL.

Data from wells tested during January 2003 in Lumbini district							
Well	Sample Name	Millipore Membrane Filtration ^b				E. Coli (cfu/100 mL)	Total Coliform (cfu/100 mL)
		Time Sampled	Time Incubated	Time Lag			
DW9		14:27	1/7/2003 11:41	21:14	0	15	
B14		12:30	18:30	6:00	0	55	
B15		13:00	18:05	5:05	4	>1004	
B16		12:54	18:19	5:25	28	>628	
L1	L1 - 100 mL	14:55	17:30	2:35	0	>100	
	L1 - 10 mL	14:55	17:42	2:47	10	160	
L2		--	--	--	--	--	
M3	M3 - 100 mL	15:20	17:00	1:40	0	>20	
	M3 - 5 mL	15:20	17:10	1:50	0	0	
BUD1		15:10	15:23	0:13	0	1	
BUD2		15:00	15:23	0:23	0	140	
BUD3		14:45	16:30	1:45	0	0	
BUD4		14:40	17:15	2:35	0	3	
BUD5		14:30	16:25	1:55	0	50	
BUD6		14:20	17:15	2:55	4	239	
BUD7	BUD7 - 100 mL	14:10	16:05	1:55	0	25	
	BUD7 - 100 mL	14:10	16:35	2:25	0	30	
BUD_SK		14:50	16:00	1:10	0	0	
BUD_CK		--	--	--	0 ^c	280 ^c	
MUH4		13:00	15:00	2:00	0	85	
MUH5		12:50	15:12	2:22	0	4	
MUH6		12:20	15:12	2:52	0	1	
MUH7		12:40	15:35	2:55	0	2	
MUH8		13:10	14:45	1:35	1	33	

^aSample volumes are 20 mL.

^bUnless otherwise specified, sample volumes are 100 mL.

^cSampled by Xanat Flores

Wells tested during January 2003 in Lumbini district							
Well	Date Visited	Type	Village	Depth (ft)	Age	GPS	Comments
DW9	1/6/2003	Artesian	Dhodahawa	350	4	N 27°29.019' E 083°13.960'	
B14	1/9/2003	IBS hand pump	Bhagawanpur	200	4	N 27°26.492' E 083°15.392'	
B15	1/9/2003	IBS hand pump	Bhagawanpur	230	4	N 27°26.530' E 083°15.351'	
B16	1/9/2003	IBS hand pump	Bhagawanpur	190	4	N -- E --	
L1	1/9/2003	IBS hand pump	Lamihawa	200	2	N 27°25.931' E 083°17.558'	plain opposite school
L2 (broken)	1/9/2003	IBS hand pump	Lamihawa	180	2	N 27°25.970' E 083°17.562'	
M3	1/9/2003	IBS hand pump	Mujahana	230	4	N 27°26.440' E 083°17.620'	
BUD1 ^a	1/14/2003	local hand pump	BuddhaNagar			N 27°28.276' E 083°17.176'	junction of highway and main street
BUD2	1/14/2003	local hand pump	BuddhaNagar			N 27°28.294' E 083°17.176'	on left ^b in front of IBS clinic entrance
BUD3	1/14/2003	local hand pump	BuddhaNagar			N 27°28.280' E 083°17.232'	on right ^b btwn restaurant & house w/pink porch, green walls
BUD4	1/14/2003	local hand pump	BuddhaNagar			N 27°28.271' E 083°17.297'	near utility pole on right ^b in front of mud-walled house, brick house
BUD5	1/14/2003	local hand pump	BuddhaNagar			N 27°28.289' E 083°17.329'	on right ^b in btwn 2 mud-walled houses
BUD6	1/14/2003	local hand pump	BuddhaNagar			N 27°28.291' E 083°17.370'	on right ^b in btwn brick building & mud-walled house
BUD7	1/14/2003	local hand pump	BuddhaNagar			N 27°28.327' E 083°17.419'	across from power station on left ^b adj. to narrow building w/white walls & blue doors
BUD_SK Siddarth Kumar	1/14/2003	private hand pump	BuddhaNagar			N 27°28.298' E 083°17.256'	inside house
BUD_CK Chandra Kala	1/14/2003	private hand pump	BuddhaNagar			N 27°28.273' E 083°17.141'	in front of house where we ate dinner
MJH4	1/16/2003	IBS hand pump	Muhwari	195	1	N 27°26.434' E 083°13.675'	
MJH5	1/16/2003	IBS hand pump	Muhwari	191	1	N 27°26.486' E 083°13.613'	
MJH6	1/16/2003	IBS hand pump	Muhwari	150	3	N 27°26.432' E 083°13.661'	
MJH7	1/16/2003	IBS hand pump	Muhwari	195	3	N 27°26.466' E 083°13.614'	
MJH8	1/16/2003	IBS hand pump	Muhwari	203	3	N 27°26.404' E 083°13.686'	

^aall local BuddhaNagar hand pumps along main street

^bwhen facing away from Butwal-Kathmandu highway

APPENDIX C

ENPHO Results²⁴

²⁴ Results provided by ENPHO

1-day tests								Faecal coliform counts [CFU/100 ml]					removal rates [%]				remarks			
location	date	Elevation in meters (m)	exposure time [h]	insolation [Wh/m ²]	weather *	max. temp. of bottles on roof	max. temp. of bottles on reflective surface	control (black bottle)	clear bottle on roof	half black bottle on roof	clear bottle on reflective surface	half black bottle on reflective surface	clear bottle on roof	half black bottle on roof	clear bottle on reflectiv e	half black bottle on reflectiv				
Kathmandu	5/10/2002	1500	8	2400	3	N/A	N/A	320	3	20	N/A	N/A	99.1	93.8			Mostly cloudy day, some rain			
Ghorepani	5/15/2002	2800	6.5		3	N/A	19.5	3000	2	1200	1	600	99.9	60	100	80	1 hour of direct sunshine			
Ghorepani	5/16/2002	2800	7.5		4	16	18	820	72	390	0	340	91.2	52.4	100	58.54	cloudy all day			
Ghorepani	5/17/2002	2800	7		4	19	20	20	0	1	0	0	100	95	100	100	cloudy all day			
Ghandruk	5/19/2002	2000	7		2	33	36.5	860	0	0	0	0	100	100	100	100	6 hours of clear sky			
Ghandruk	5/20/2002	2000	5.5		2	38	38.5	11500	1	14	0	0	100	99.9	100	100	4 hours of clear sky			
Ghandruk	5/21/2002	2000	5.5		2	32.5	34	TNTC**	TNTC	TNTC	TNTC	TNTC		N/A			too numerous to count, well above 10'000 for all samples			
Kathmandu	6/2/2002	1500	6	4500	2	43.5	44.5	600	0	0	0	0	100	100	100	100	nice, some clouds, 30 degrees			
Kathmandu	7/1/2002	1500	7	2050	4	32	34	20000	3	63	0	4	100	99.7	100	99.98	fully cloudy day, rain			
Kathmandu	7/11/2002	1500	5	1200	4	27	29	5000	102	260	15	123	98	94.8	99.7	97.54	fully cloudy day			
Sauraha	7/16/2002	160	7	4000	2	39	39.5	12000	0	0	0	0	100	100	100	100	Temp. Measured in afternoon			
Sauraha	7/17/2002	160	7	2400	3	43	43.5	28000	3	17	7	2	100	99.9	100	99.99	Only one hour of clear sky			
Sauraha	7/18/2002	160	5	3800	2	47	48.5	5500	0	0	0	0	100	100	100	100	hot weather			
Sauraha	7/18/2002	160	6	4100	2	47	48.5	2500	0	0	0	0	100	100	100	100	hot weather			
Ghandruk	7/20/2002	2000	4.5	550	4	19.5	19	8000	1	1200	130	2000	100	85	98.4	75	exposed from 1 to 5:30 PM			
Ghandruk	7/21/2002	2000	6.5	1150	4	23.5	22.5	4000	53	2500	340	3000	98.7	37.5	91.5	25	the roof is a stone roof			
Ghandruk	7/22/2002	2000	6	850	4	21.5	20.5	3000	24	1000	150	1200	99.2	66.7	95	60	the roof is a stone roof			
Pokhara	7/24/2002	800	6.5	3970	4	46	47.5	6000	0	0	0	0	100	100	100	100	thin cloud layer all day, hot			
Pokhara	7/25/2002	800	7.5	1200	4	28	28	1200	0	20	1	8	100	98.3	99.9	99.33	Temp. measured in afternoon			
Pokhara	7/26/2002	800	5	3250	3	43	46	660	0	0	0	0	100	100	100	100	thin cloud layer all day, hot			
Kathmandu	8/7/2002	1500	4.5	4000	1	42.5	44	5000	0	0	0	0	100	100	100	100	nice, clear day			
Kathmandu	8/15/2002	1500	6	2500	3	24.5	25	2000	0	6	1	0	100	99.7	100	100	Mostly sunny morning, cloudy afternoon, some rain			
Jomsom	8/22/2002	2700	5.5	3150	2	25	26	36000	0	1	0	1	100	100	100	100	started at 12 PM			
Jomsom	8/23/2002	2700	6	4150	3	26	27	10000	0	0	0	3	100	100	100	99.97	thin layer of cloud all day except for 1 hour, rain in mornin			
Jomsom	8/24/2002	2700	6.5	4300	2	24	25	1400	0	0	0	0	100	100	100	100	cloud patches visible all day, but no cloud layer			
Muktinath	8/26/2002	3700	4.5	940	4	15.5	16	3500	96	420	20	500	97.3	88	99.4	85.71	started at 1:15 PM, cloudy all afternoon			
Muktinath	8/27/2002	3700	6	3600	3	22.5	24	1100	0	0	1	1	100	100	99.9	99.91	mostly cloudy day, some rain, intermittent sunshine			
Muktinath	8/28/1992	3700	4.5	2050	3	20	21	6200	48	160	11	490	99.2	97.4	99.8	92.1	started at 12 PM, rain splashed mud on bottles			
average			6.05357	2732.3	3.0	30.71	31.31481	6599.3	15.111	269.33	26.038	318.15	99.4	91.4	99.4	91.27				
								avg. all treatments: 156.88									95.4			
* weather - 1: sunny all day, 2: mostly sunny, 3: mostly cloudy, 4: cloudy all day																				
** TNTC: too numerous to count																				
untreated	clear bottle on roof	half- black bottle on roof	clear half- bottle on black corrugat ed iron on Cl	6599	15	269	26	318												

2-day tests							Faecal coliforms [CFU/100 ml]					removal rates [%]				remarks		
location	date	exposure time [h]	insolation [Wh/m ²]	weather *	max. temp. of bottles	max. temp. of bottles on reflective	control (black bottle)	clear bottle on roof	half black bottles on roof	clear bottles on reflective surface	half black bottles on reflective surface	clear bottle on roof	half black bottle on roof	clear bottle on reflective surface	half black bottle on reflective surface			
Ghorepani	15./16.05.02	6.5+7.5	N/A	3/4	16	19.5	3060	0	113	0	250	100	96.31	100	91.83			
Ghorepani	16./17.05.02	7.5+7	N/A	4/4	19	20	840	0	205	0	160	100	75.6	100	80.952			
Ghandruk	19./20.05.02	7+5.5	N/A	2/2	38	38.5	260	0	0	0	0	100	100	100	100			
Ghandruk	20./21.05.02	5.5.+5.5	N/A	2/2	38	38.5	1360	0	1	0	0	100	99.93	100	100			
Sauraha	16./17.7.02	7+7	4000+2400	2/3	43	43.5	100000	0	0	0	0	100	100	100	100			
Ghandruk	20./21.07.02	4.5.+6.5	550+1150	4/4	23.5	22.5	5000	4	80	2	63	99.92	98.4	99.96	98.74			
Pokhara	23./24.07.02	4.5+6.5	500+3970	4/4	46	47.5	1300	0	0	0	0	100	100	100	100			
Pokhara	25./26.07.02	7.5+5	1200+3250	4/3	43	46	1200	0	0	0	0	100	100	100	100			
Jomsom	22./23.08.02	5.5+6	3150+4150	3/3	26	27	5000	0	0	0	0	100	100	100	100	mostly cloudy days, but only thin cloud layers		
Muktinath	26./27.08.02	4.5+6	950+3600	4/3	22.5	24	40	0	2	0	9	100	95	100	77.5	low contamination (due to cold water?)		
Muktinath	27./28.8.02	6+4.5	3600+2050	3/3	22.5	24	480	0	0	1	0	100	100	99.7917	100	rain on second day splased mud on bottles		
average							30.7	31.909	10776	0.36	36.455	0.27273	43.81818	99.99	96.84	99.9774	95.366	avg. All treatments: 98.0437048
* weather - 1: sunny all day, 2: mostly sunny, 3: mostly cloudy, 4: cloudy all day																		

1-day tests								Fascal odiform counts (CFU/100 ml)					removal rates [%]				remarks
location	date	Elevation in meters (m)	exposure time [h]	Insolation [Wh/m ²]	weather*	max temp. of bottles on roof	max temp. of bottles on reflective surface	control (black bottle)	clear bottle on roof	half black bottle on roof	clear bottle on reflective surface	half black bottle on reflective surface	clear bottle on roof	half black bottle on roof	clear bottle on reflective surface	half black bottle on reflective surface	
Kathmandu	5/10/2002	1500	8	2400	3	N/A	N/A	320	3	20	N/A	N/A	99.1	93.8			Mostly cloudy day, some rain
Kathmandu	6/2/2002	1500	6	4500	2	43.5	44.5	600	0	0	0	0	100	100	100	100	nice, some clouds, 30 degrees
Kathmandu	7/1/2002	1500	7	2050	4	32	34	20000	3	63	0	4	100	99.7	100	99.98	fully cloudy day, rain
Kathmandu	7/11/2002	1500	5	1200	4	27	29	5000	102	260	15	123	98	94.8	99.7	97.54	fully cloudy day
Kathmandu	8/7/2002	1500	4.5	4000	1	42.5	44	5000	0	0	0	0	100	100	100	100	nice, clear day
Kathmandu	8/15/2002	1500	6	2500	3	24.5	25	2000	0	6	1	0	100	99.7	100	100	Mostly sunny morning, cloudy afternoon, some rain
Ghandruk	5/20/2002	2000	5.5		2	38	38.5	11500	1	14	0	0	100	99.9	100	100	4 hours of clear sky
Ghandruk	5/21/2002	2000	5.5		2	32.5	34	TNTC**	TNTC	TNTC	TNTC	TNTC		N/A			too numerous to count, well above 10'000 for all samples
Ghandruk	7/20/2002	2000	4.5	550	4	19.5	19	8000	1	1200	130	2000	100	85	98.4	75	exposed from 1 to 5:30 PM
Ghandruk	7/21/2002	2000	6.5	1150	4	23.5	22.5	4000	53	2500	340	3000	98.7	37.5	91.5	25	the roof is a stone roof
Ghandruk	7/22/2002	2000	6	850	4	21.5	20.5	3000	24	1000	150	1200	99.2	66.7	95	60	the roof is a stone roof
average			5.8636	2133.33	3.0	30.45	31.1	5942	18.7	506	70.7	703	99.5	87.7	98.3	84.17	
								avg. all treatments:	321				92.5				
Ghorepani	5/15/2002	2800	6.5		3	N/A	19.5	3000	2	1200	1	600	99.9	60	100	80	1 hour of direct sunshine
Ghorepani	5/16/2002	2800	7.5		4	16	18	820	72	390	0	340	91.2	52.4	100	58.54	cloudy all day
Ghorepani	5/17/2002	2800	7		4	19	20	20	0	1	0	0	100	95	100	100	cloudy all day
Ghandruk	5/19/2002	2000	7		2	33	36.5	860	0	0	0	0	100	100	100	100	6 hours of clear sky

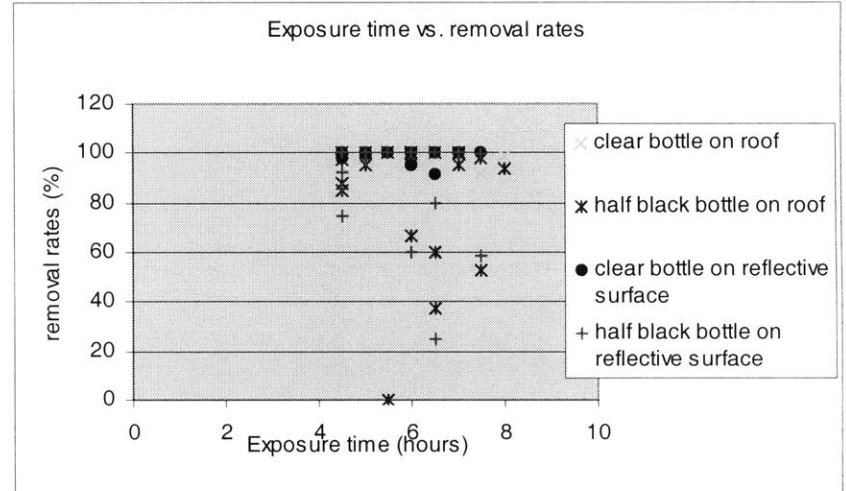
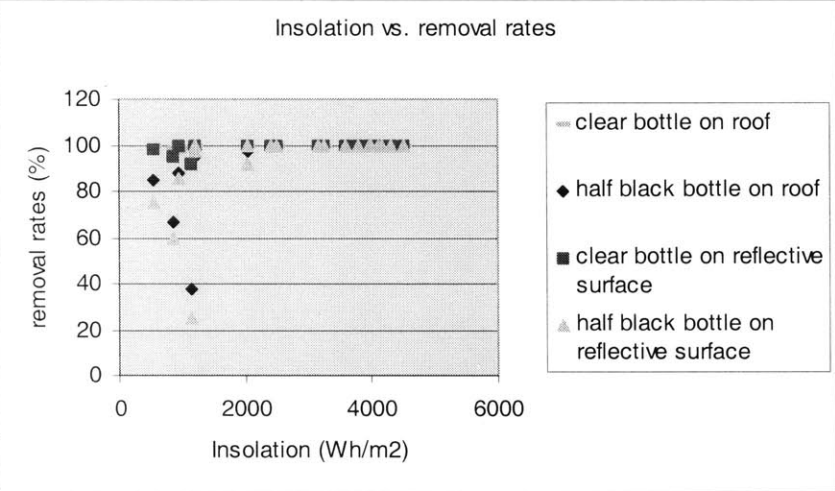
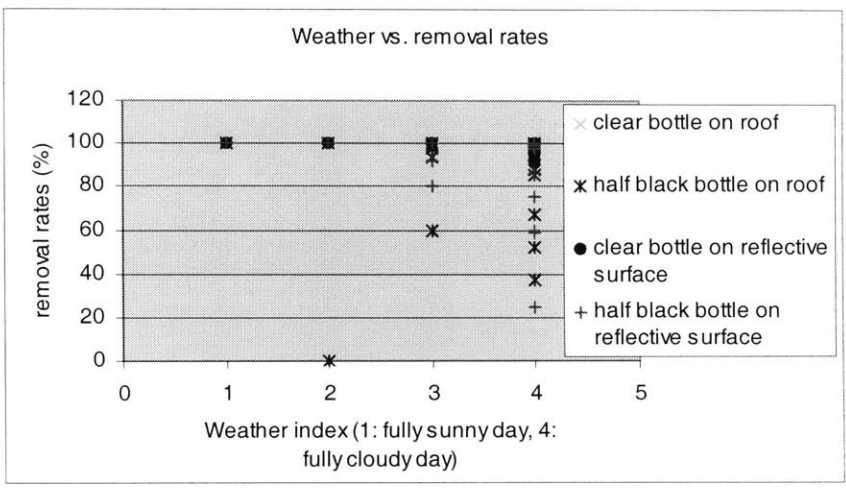
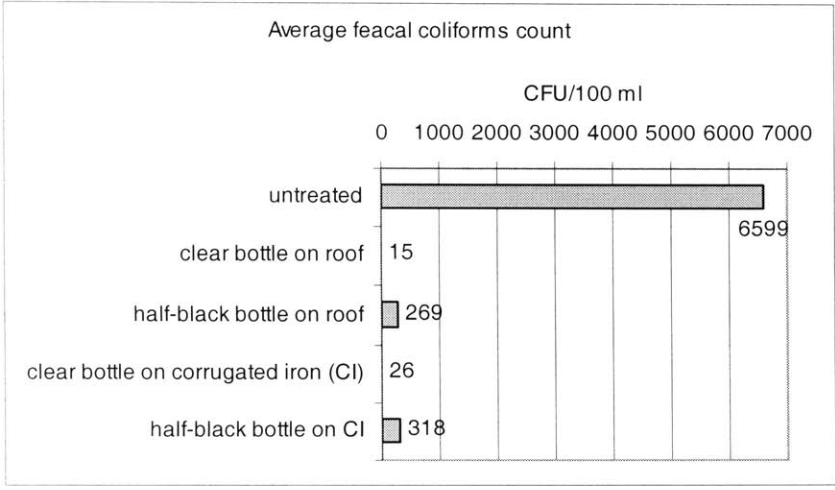

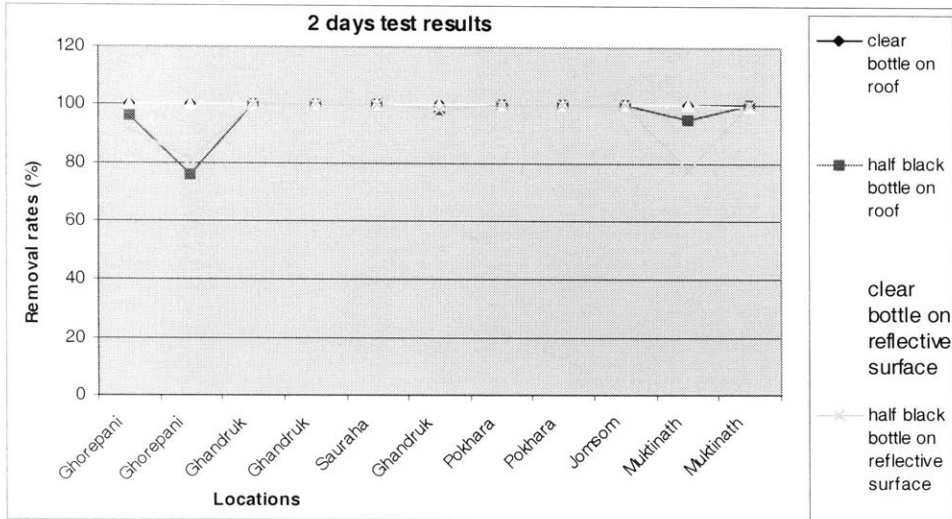

APPENDIX D

Pictures:

SC-SODIS “in the Lab”
SC-SODIS in Lumbini
SC-SODIS in Ashdown Roof
SC-SODIS tracer test



SC-SODIS “in the lab” (at M.I.T.)



SC-SODIS in Lumbini (IBS roof)



SC-SODIS in Ashdown Roof (Cambridge, MA)



SC-SODIS tracer test

APPENDIX E

Tracer Test Measurements and Analysis

TRACER TEST MEASUREMENTS AND ANALYSIS

A tracer test was made in order to provide a quantifiable measurement of the coliforms removal in the SC-SODIS system. This tracer test also provides an idea of the type of behavior within the system. However, due to the diverse conditions under which the system SC-SODIS can be used, the approximations and assumptions made in this analysis might not satisfy the conditions of other places, times, seasons, etc.

The tracer test helped determine the residence time distribution (RTD) that represents the distribution of the outflow of the system and indicates the mixing and flow distribution patterns that can be found within the reactor.

Methodology.

The system was built as shown in Appendix D (Tracer test) and measurements were taken every hour for the first nine hours and every half an hour for the following thirteen hours. Measurements every half an hour were taken. The tracer used for this test was rhodamine which was diluted into the water source bucket that feeds the individual reactor of the SC-SODIS system.

The flow of the system was set at 2.37 ± 0.5 ml/min, to give a residence time of 16 hours with an lower and upper limits of 13.24 hours and 20.32 hours respectively.

Aliquots of 10ml were taken and analyzed using the Fluorometer Model 10-AU from Turner Designs, Sunnyvale, California. The results are shown in the table.



Fluorometer Model 10AU,
Sunnyvale, California

Analysis.

Based on the shape of the response curve t/τ vs C_{in}/C three models to describe the behavior of the dye within the SC-SODIS system were considered:

1. Series of fully mixed tanks responding to continuous mass input (step input).

This model considers the situation in which a mass $C_{in}Q_j$ enters (step input) at a $t_j=0$ a series of n continuous flow tanks equal-sized. The equation that describes this model is:

$$\frac{C(t)}{C_{in}} = \frac{1}{(\tau\kappa)^n} \left[1 - e^{-\kappa t} \left(1 + \kappa t + \frac{(\kappa t)^2}{2} + \dots + \frac{(\kappa t)^{n-1}}{(n-1)!} \right) \right]$$

Where $\kappa=k+1/\tau$, k is the constant of a first order reaction, t is the residence time of a single tank, and n are the number of tanks equal the equivalent dispersion can be found with two relationships:

$$n = (P+1)/2$$

where

$$P = vL/E_L$$

Where P is the Peclet number, v is the velocity of the fluid, L the length of the individual box, and E_L the longitudinal turbulent-diffusion coefficient (Adams, 2003).

The following figure shows the equation for $k=0$ and different n numbers of fully mixed tanks.

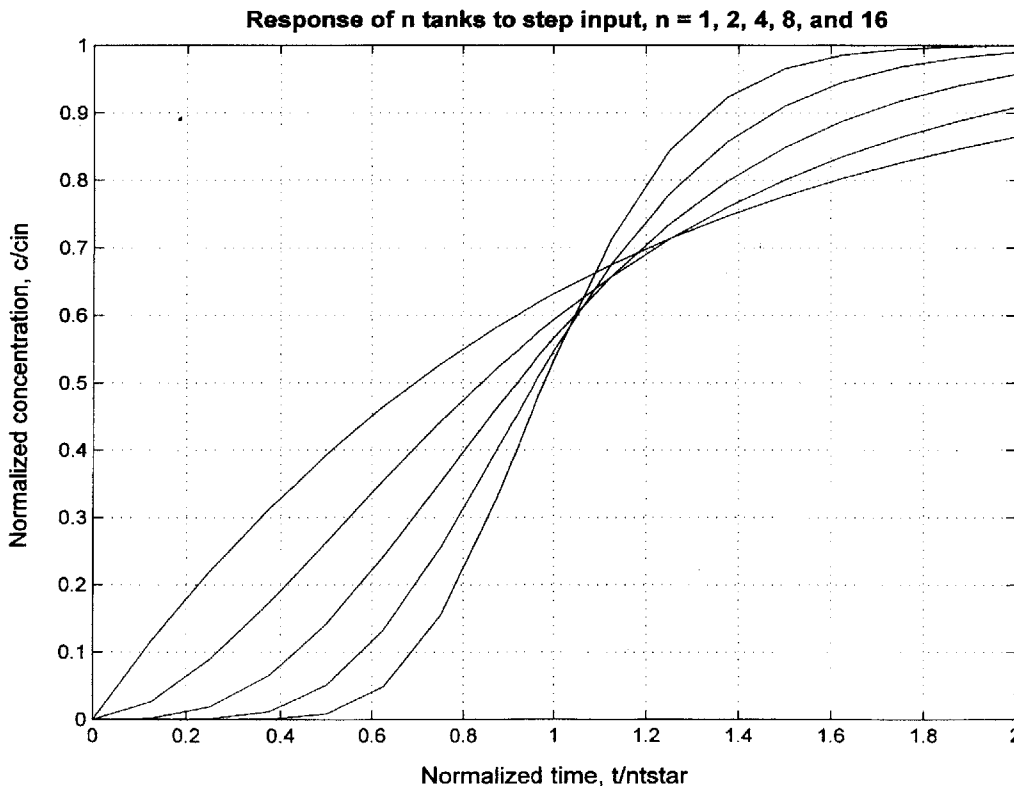

Figure 1. Response of n Fully Mixed Tanks to Step Input
Source: Adams, 2003b

2. Continuous plane source dispersion.

This is based on a one dimensional concentration distribution produced by a continuous discharge plane with no downstream boundary. The equation that represents concentrations at location L is:

$$c = \frac{q'' e^{\frac{L\Omega}{2E_L}}}{2\Omega} \left[\left\{ \operatorname{erf} \left[\frac{L + \Omega t}{\sqrt{4E_L t}} \right] \pm 1 \right\} \exp \left[\frac{L\Omega}{2E_L} \right] - \left\{ \operatorname{erf} \left[\frac{L - \Omega t}{\sqrt{4E_L t}} \right] \pm 1 \right\} \exp \left[-\frac{L\Omega}{2E_L} \right] \right]$$

Where the plus and minus signs are for negative and positive values of L respectively, and

c = concentration at any given time

$q'' = vC_{in}$

$\Omega = (v^2 + 4kE_L)^{-1/2}$

$E = L^2/4E_L$

Remembering the Peclet number (P) equals vL/E , the following figure shows the case $k=0$ for different Peclet numbers (see Figure 2).

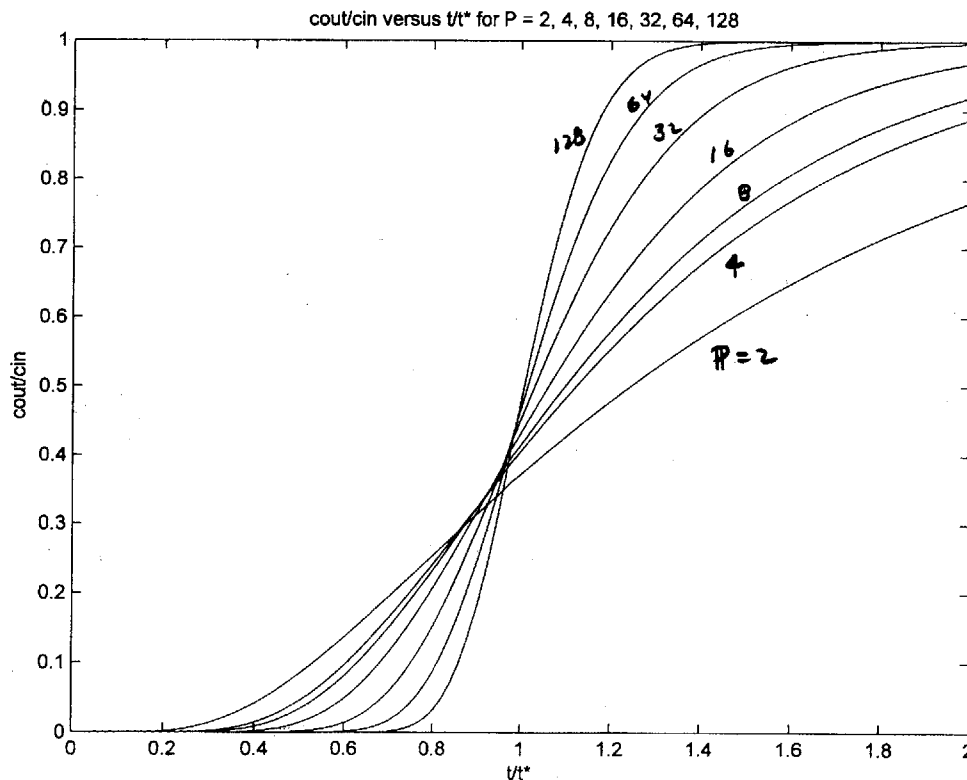

Figure 2. Continuous Plane Source Dispersion for Different Peclet Numbers
Source: Adams, 2003b

3. Plug Flow

In this case all the particles of the contaminant follow the same path on the elements before it without intermixing, and leave the reactor the same way. For this case, the Peclet number is infinite, and the equation without any reaction (i.e. $k=0$) is simply:

$$C_{in}=C \quad \text{at time } t-\tau$$

Comparing the curves from the tracer test with the ones that describe the different patterns, the one that fitted best was the one in between plug flow and fully mixed reactors. The curves that describe best the behavior observed of the SC-SODIS, are the ones of the continuous plane source dispersion, with Peclet numbers between 16 and 128. This also tells us of the proximity of the regime to a plug flow; however, in order to obtain a better quantification of the efficiency, a Peclet number of 32 will be used.

Having estimated the Peclet number for the laboratory test with a step input in dye concentrations, the result can be used to determine the residence time distribution (RTD) for a pulse input (see the Figure below). The RTD in time can be used to estimate the concentrations of outflow in water as a weighted average of the concentrations of inflowing water at all the previous times.

From the figure below we can see that there are two extreme cases: in the first case the Peclet number tends to infinity and the longitudinal dispersion to zero (plug flow), while in the second one the longitudinal dispersion coefficient and the Peclet number tends to infinite and zero respectively (fully mixed tank).

It is important to remind the lector that the RTD might change depending on ambient conditions. In a warmer weather we might find the Peclet number to decrease due to temperature differences, and in colder climate to increase. Here the tracer test was made inside a room, which kept the temperature of the water higher than the source water used in Lumbini, Nepal; in a colder weather, it would be expected to be more similar to plug flow.

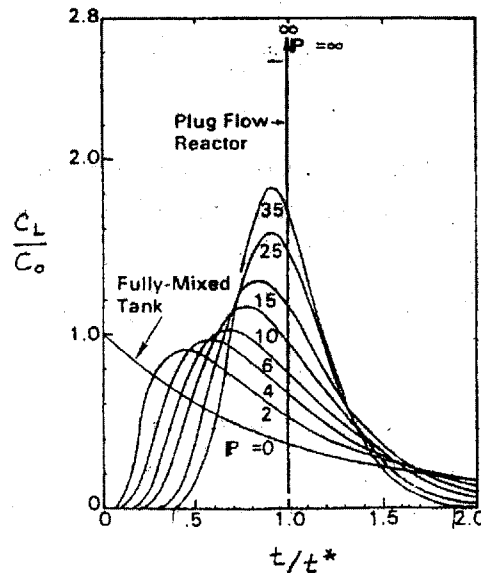

Response Curves for Different Peclet Numbers
Source, Adams, 2003b

Time	Elapsed hrs	Relative Rothamide			Blank	Rel. Av. Rothamide				
		Concentration (µg/L)				Concentration (µg/L)	C/C _{in}	τ _{2eq, days}	τ _{1.66eq, Days}	τ _{2.54eq, days}
22:30	0	0.285			0.354	0.29	0.00197	0	0	0
23:30	1.00	0.297			0.34	0.30	0.00205	0.0625	0.05	0.075529
0:30	2.00	0.244			0.223	0.24	0.00168	0.125	0.1	0.151057
1:30	3.00	0.237			0.23	0.24	0.00163	0.1875	0.15	0.226586
2:30	4.00	0.22			0.242	0.22	0.00152	0.25	0.2	0.302115
3:30	5.00	0.216			0.22	0.22	0.00149	0.3125	0.25	0.377644
4:30	6.00	0.218			0.212	0.22	0.0015	0.375	0.3	0.453172
5:30	7.00	0.32	0.324		0.217	0.32	0.00222	0.4375	0.35	0.528701
6:30	8.00	1.12	0.884	0.992	0.215	1.00	0.00689	0.5	0.4	0.60423
7:30	9.00	5.33	6.37		0.218	5.85	0.04034	0.5625	0.45	0.679758
8:00	9.50	5.64	7.59	7.01	0.221	6.75	0.04653	0.59375	0.475	0.717523
8:30	10.00	13.4	13.5	14.4	0.234	13.77	0.09494	0.625	0.5	0.755287
9:00	10.50	12.7	13.8	13.1	0.265	13.20	0.09103	0.65625	0.525	0.793051
9:30	11.00	19.6	19.03		0.254	19.32	0.13321	0.6875	0.55	0.830816
10:00	11.50	15	13.5	14.5	0.267	14.33	0.09885	0.71875	0.575	0.86858
10:30	12.00	17.3	16.6	17.5	0.275	17.13	0.11816	0.75	0.6	0.906344
11:05	12.58	18.7	19.1	17.5	0.245	18.43	0.12713	0.786458	0.629167	0.950403
11:40	13.17	19	17.4		0.251	18.20	0.12552	0.822917	0.658333	0.994461
12:00	13.50	18.5	19.7	19.8	0.278	19.33	0.13333	0.84375	0.675	1.019637
12:30	14.00	19.6	19	18.5	0.267	19.03	0.13126	0.875	0.7	1.057402
13:00	14.50	24.1	23.7	22.1	0.284	23.30	0.16069	0.90625	0.725	1.095166
13:20	14.83	23.51	22.9	22.8	0.256	23.07	0.1591	0.927083	0.741667	1.120342
13:40	15.17	26.5	27.1	25.8	0.267	26.47	0.18253	0.947917	0.758333	1.145519
14:00	15.50	28.6	29.1	28.8	0.279	28.83	0.19885	0.96875	0.775	1.170695
14:30	16.00	32	32.1	32	0.281	32.03	0.22092	1	0.8	1.208459
15:00	16.50	31.2	31.6		0.285	31.40	0.21655	1.03125	0.825	1.246224
15:30	17.00	35.1	34.8		0.278	34.95	0.24103	1.0625	0.85	1.283988
16:00	17.50	37.6	37.8		0.283	37.70	0.26	1.09375	0.875	1.321752
16:30	18.00	42.3	42.4		0.276	42.35	0.29207	1.125	0.9	1.359517
17:00	18.50	39.6	40.6		0.291	40.10	0.27655	1.15625	0.925	1.397281
17:30	19.00	42.3	42.1		0.302	42.20	0.29103	1.1875	0.95	1.435045
18:00	19.50	51.9	49.3		0.291	50.60	0.34897	1.21875	0.975	1.47281
18:30	20.00	55.1	56.1	54.3	0.287	55.17	0.38046	1.25	1	1.510574
19:00	20.50	60.1	59.7	61.3	0.267	60.37	0.41632	1.28125	1.025	1.548338
19:30	21.00	66.7	69.8	65.8	0.279	67.43	0.46506	1.3125	1.05	1.586103
20:00	21.50	76.8	76.5	75.3	0.285	76.20	0.52552	1.34375	1.075	1.623867
20:30	22.00	90.3	92.5	90	0.289	90.93	0.62713	1.375	1.1	1.661631
21:30	22.50	105	103	102	0.303	103.33	0.71264	1.40625	1.125	1.699396
22:00	23.50	103	105		0.305	104.00	0.71724	1.46875	1.175	1.774924
22:30	24.00	113	116		0.297	114.50	0.78966	1.5	1.2	1.812689
0:00	26.50	150	144		0.298	147.00	1.01379	1.65625	1.325	2.001511

Source		144	146		0.291	145.00	1			
--------	--	-----	-----	--	-------	--------	---	--	--	--

Results From Tracer Test

Comparison τ vs C_{in}/C

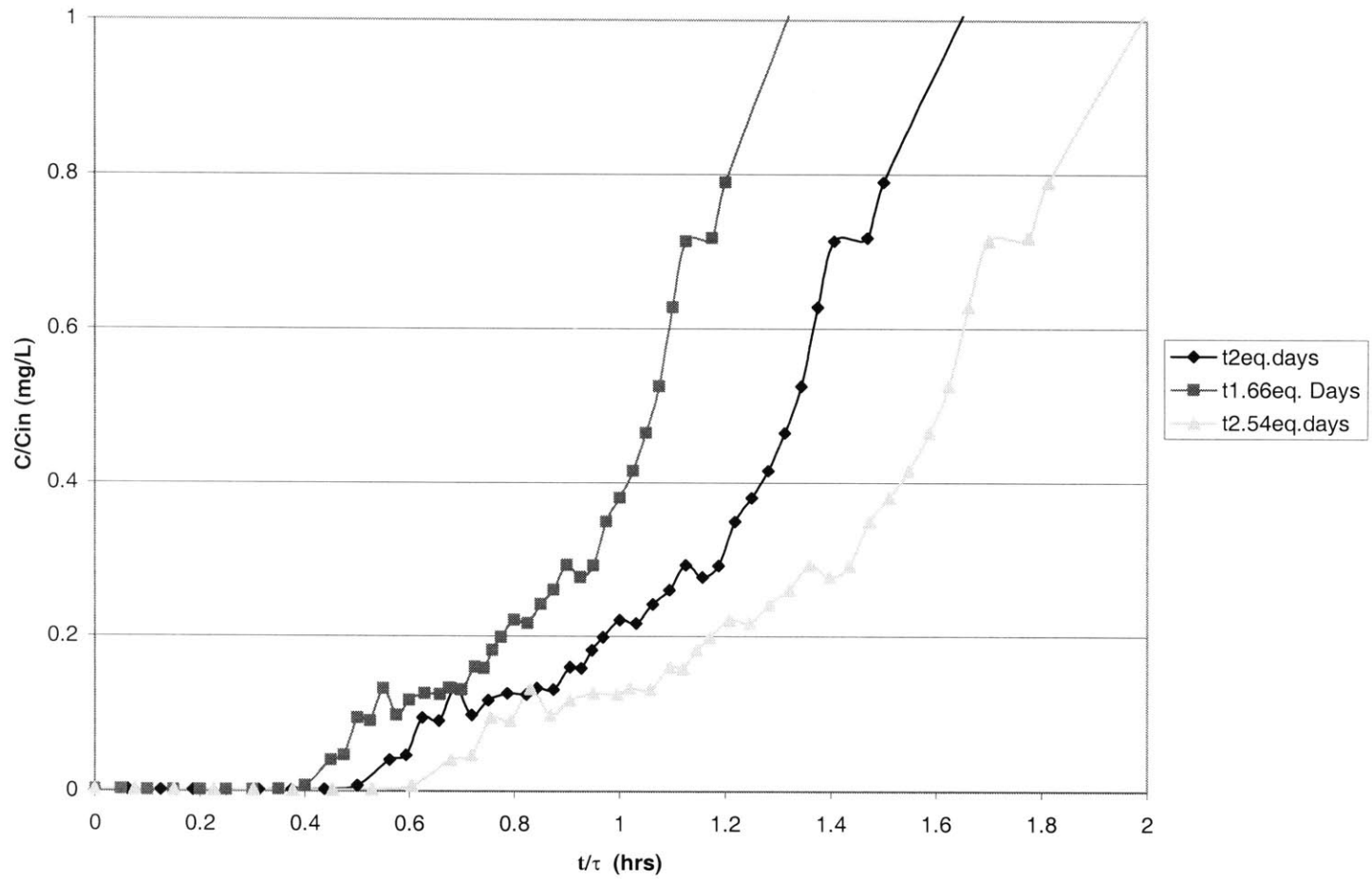

Response Curve t/τ vs C/C_{in}

After choosing the RTD (see below), the following equation was used to determine a weighted average initial concentration to compare with each one of our outflows and therefore be able to determine our efficiencies.

$$\langle C_{in}(t) \rangle = \frac{\sum_{i=0}^{\infty} C_{in}(t - i\Delta t) * y(i\Delta t / \tau)}{\sum_{i=0}^{\infty} y(i\Delta t / \tau)}$$

Where $y = CL/Co$ for the Peclet number chosen.

Finally, the percentage of *E. coli* or total coliforms removed is given by:

$$\% \text{ Removal} = 100 * \left[1 - \frac{C_{out}(t)}{\langle C_{in}(t) \rangle} \right]$$

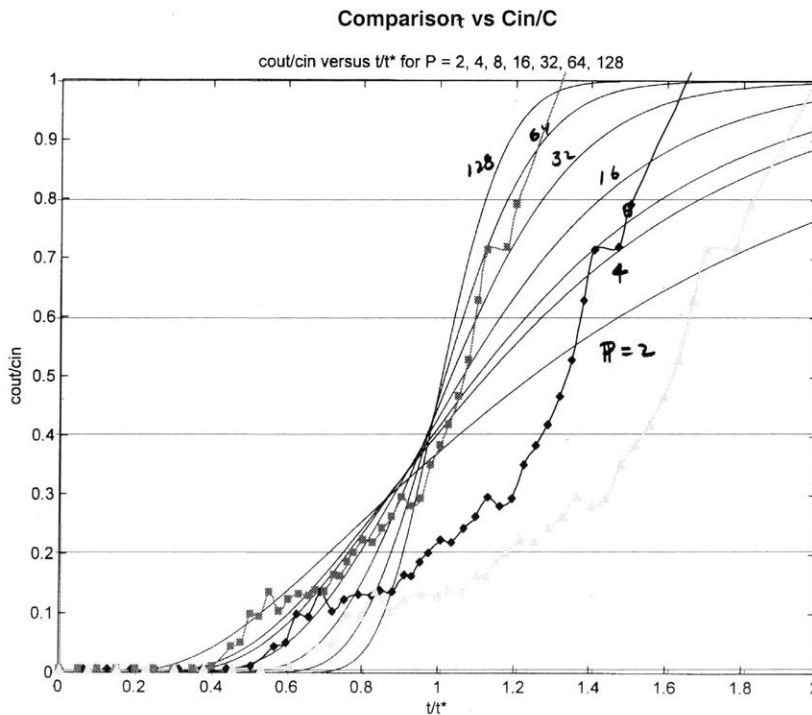

Comparison of Curves for Continuous Plane Source Dispersion
with Results form Tracer Test

APPENDIX F

Construction Manual SC-SODIS

Supplies:

1. Eight PET bottles
2. 200 cm ½ in PVC pipe Schedule 40 (see Chapter 5)
3. Six Tees ½ in PVS pipe Schedule 40 fittings
4. Four 90° Elbows ½ in PVC pipe Schedule 40 fittings
5. One ½ in butterfly or needle valve
6. One 80x 60 cm corrugated iron sheet or other available reflective support²⁵
7. Eight plastic bags, rubber or plastic sheet.

Tools:

1. Sharp knife
2. Hack saw
3. Sand paper or round metal file
4. Measuring tape
5. Permanent marker
6. Glue chosen
7. Scissors
8. Broom w/ dust pan
9. Safety glasses (if available)

²⁵ The support can be the roof of the house where the system will be installed

PROCEDURE

I. Individual Reactors²⁶

Step 1. Rinse the PET bottles, remove cap and tag and let them dry.

Step 2. Choose two bottles of the same brand and size.

Step 3. Using the cutter, cut both ends off the PET bottles no more than two cm from the bottom.

Step 4. Using a medium coarse sand paper, sand the inside wall of one of the bottle ends (bottle 1), and the outside wall of the other one (bottle 2). This will create a diameter difference between both bottles.

Step 5. Check if bottle 1 fits into bottle 2. If it does go Step 6. If it does not, go to Step 4.

Step 6. Add some of the glue chosen based on the recommended characteristics (see Chapter 5, Section 5.2) to the outer walls of the sanded part of bottle 1 and fit it into bottle 2.

Step 7. Allow specified time for the glue to dry before use.

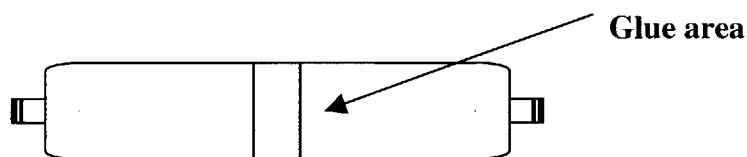

II. The piping system²⁷

Step 1 Using the hack saw to cut the PVC pipe to the following pieces (use the marker to mark guidelines):

- 6 pieces 21 cm long
- 4 pieces 10.5 cm long
- 8 pieces 7 cm long

Step 2. Smooth ends with sandpaper (or iron flint) to remove all burns

Step 3. Using the 21cm long and 10.5 cm long pieces, put the following structure together²⁸.

²⁶ This construction manual contains the author's recommendations on how to build the reaction unit. However, due to the fact that this is a novel system, changes and suggestions are welcome.

²⁷ If available wear safety glasses.

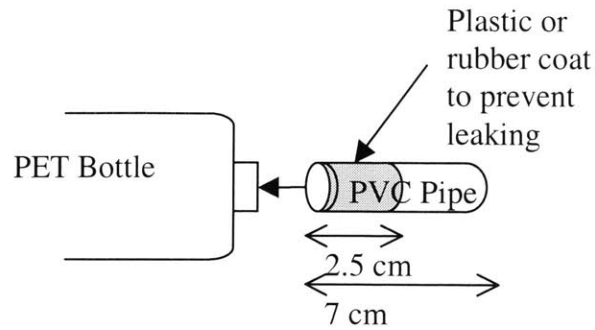

Step 3. Fit the PVC pipe covered end into the individual reactors

Step 4. Fit the PVC pipe non-covered end into PVC pipe system structure constructed in part I (see figure below)

Step 5. Fit the valve into the left end of the PVC piping system as shown below.

Step 6. Set the flow, connect it to source tank and let it run!

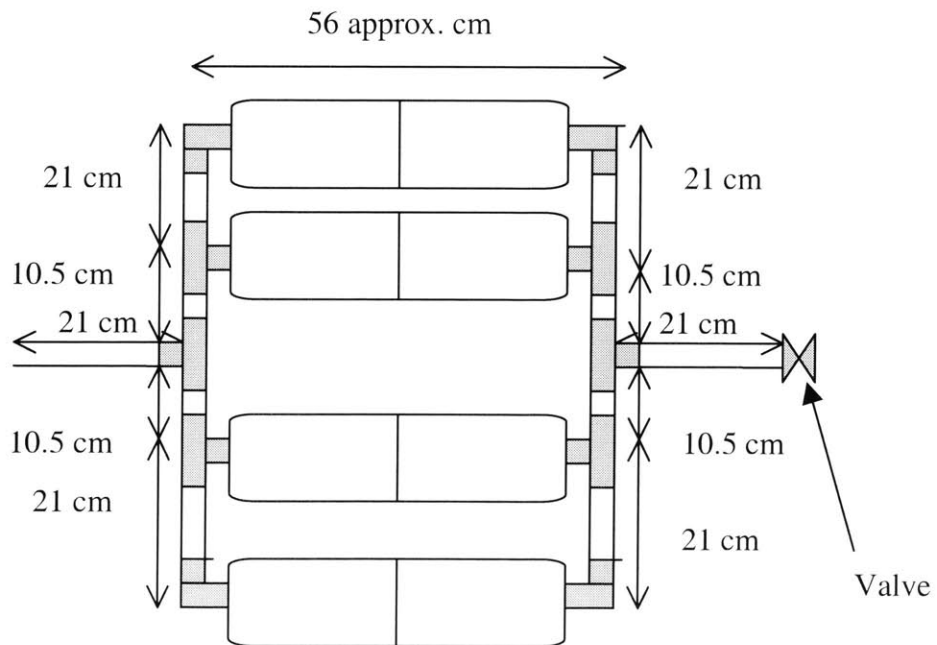

Note: the figures are not to scale

APPENDIX G

Data From IBS Clinic, Lumbini, Nepal

Data from IBS Clinic, Lumbini, Nepal August 2001-August 2002				
	Leucorrhoea	Amoebiasis	Diarrhea	Gastritis
Sonbarsha	102	130	85	120
Sonbarshi	70	55	65	84
Ramwapur	110	80	75	62
Bichauwapur	67	45	48	82
Sujandihawa	188	165	103	131
Bhagwanpur	156	140	133	110
Dhodhawa	175	95	58	53
Ramwapur	112	94	62	33
Shivgadiya	132	75	46	47
Mehilwari	75	54	36	19
Sekhuaded	16	28	20	12
Lankapur	18	22	32	15
Mujhaua	183	146	92	77
Laxmipur	110	72	41	47
Manauri	156	195	53	91
Mahuwari	108	82	41	23
Bhujaihiya	141	120	70	60
Lamtihawa	137	78	43	27
Ekla	116	127	78	81
Khabhe	97	76	28	38
Bhagatpurwa	42	59	30	23
Tenuhawa	130	115	49	32
Mahilwar	89	77	67	47