

Simulation-Based Evaluation of Advanced Traveler Information Services (ATIS)

by
Daniel George Florian

B.Eng. in Computer Engineering (1998)
McGill University, Montreal, Canada

Submitted to the Engineering Systems Division
in partial fulfillment of the requirements for the degree of

Master of Science in Technology and Policy

at the

MASSACHUSETTS INSTITUTE OF TECHNOLOGY

September 2004

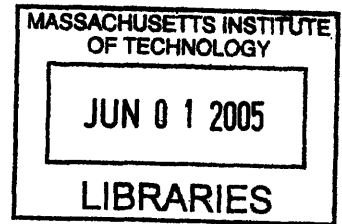

© Massachusetts Institute of Technology, 2004. All rights reserved.

Author
Engineering Systems Division
July 19, 2004

Certified by
Moshe E. Ben-Akiva
Edmund K. Turner Professor of Civil and Environmental Engineering
Thesis Supervisor

Certified by
Tomer Toledo
Research Associate, Department of Civil and Environmental Engineering
Thesis Supervisor

Certified by
Joseph Sussman
JR East Professor of Civil and Environmental Engineering and Engineering Systems
Policy Reader

Accepted by
Dava J. Newman
Professor of Aeronautics and Astronautics and Engineering Systems
Director, Technology and Policy Program

DEWEY

Simulation-Based Evaluation of Advanced Traveler Information Services (ATIS)

by
Daniel George Florian

Submitted to the Engineering Systems Division
on July 19, 2004, in partial fulfillment of the
requirements for the degree of

Master of Science in Technology and Policy

Abstract

Drivers using information from an Advanced Traveler Information System (ATIS) could potentially make better travel decisions to reduce travel time and increase trip reliability, thereby benefiting both guided drivers as well as those without such access. However, market penetration of ATIS can have dramatic effects on the performance of the transportation system in terms of overall benefits conferred as well as the distributional effects between guided and unguided drivers. Because market penetration will be determined both by private market structure and public policies, the effective deployment of ATIS depends critically on the private and public organizations that will provide these services. An understanding of the relationship between transportation system performance and ATIS market penetration provides important insights into a sustaining market structure for the ATIS industry.

This thesis provides an empirical study of the impact of ATIS on transportation network quality of service using an application of DynaMIT (Dynamic network assignment for the Management of Information to Travelers). An analysis of the simulation results serves to inform the public and private stakeholder positions in the creation of a better market for ATIS. The main results are that the provision of dynamic route guidance can simultaneously benefit the individual performance of drivers, both guided and unguided, as well as the system performance of existing transportation infrastructure. In order to perform this analysis, it was necessary to develop a new software framework for the real-time integration of DynaMIT and a Traffic Management Center (TMC).

Thesis Supervisor: **Moshe E. Ben-Akiva**
Title: Edmund K. Turner Professor
Department of Civil and Environmental Engineering

Thesis Supervisor: **Tomer Toledo**
Title: Research Associate
Department of Civil and Environmental Engineering



Acknowledgements

I would like to thank my thesis supervisors Prof. Moshe Ben-Akiva and Dr. Tomer Toledo for the opportunity to work on this project and for their continuing support, guidance and teachings, both in the lab, and, for Prof. Ben-Akiva, in the classroom as well. I would also like to thank Prof. Joseph Sussman for motivating the policy portion of this research, and for helping time and again to bridge the technology with the policy. I am also indebted to Constantinos Antoniou and Ramachandra Balakrishna for their constant direction and fresh perspectives over the course of this thesis, and to Dr. Haris Koutsopoulos for settling a number of technical debates related to ITS Lab software. Thanks also goes to Leanne Russell for managing the important stuff; expenses, finances and grades.

I also owe a sincere thanks to the gracious financial support of the Federal Highway Administration (FHWA) and the New York State Department of Transportation (NYSDOT).

The Technology and Policy Program also deserves thanks for offering an academic program that is unique, powerful and relevant. Sydney Miller was an invaluable resource in coordinating and advising on issues too numerous to mention here, and Dr. Frank Field and Prof. Richard de Neufville fostered interest in and provided perspective on a number of subjects that do not appear in this thesis. Future TPP students will undoubtedly benefit from their input and ideas.

Above all, I must thank my wonderful parents who have been an inspiration from way before I ever attended MIT, although I am partly relieved that some of my professors will no longer have the opportunity to hold me to academic standards set in the previous generation. I should also thank my friend and current roommate Ryan, as well as the regular supporting cast of Mike, J, Rob, Brian and Eric.

TABLE OF CONTENTS

SIMULATION-BASED EVALUATION OF ADVANCED TRAVELER INFORMATION SERVICES (ATIS)..... 3

 MASTER OF SCIENCE IN TECHNOLOGY AND POLICY..... 3

Abstract..... 3

1 INTRODUCTION..... 13

 1.1 ATIS AND DYNAMIC ROUTE GUIDANCE..... 14

 1.2 ATIS POLICY AND EVALUATION OF ROUTE GUIDANCE..... 18

 1.3 MOTIVATION AND THESIS OBJECTIVES 20

 1.4 SUMMARY OF RESULTS 21

 1.5 THESIS OUTLINE 22

2 LITERATURE REVIEW..... 23

 2.1 EVALUATION OF ATIS 23

 2.1.1 *Summary*..... 28

 2.2 EVALUATION FRAMEWORKS FOR DTA SYSTEMS..... 28

3 DEVELOPMENT OF A SOFTWARE INTERFACE FOR ATIS EVALUATION USING DYNAMIT 33

 3.1 OVERVIEW 33

 3.1.1 *MITSIM Network Representation* 37

 3.1.2 *MITSIM Travel Demand*..... 37

 3.1.3 *MITSIM Route Choice and ATIS* 38

 3.1.4 *MITSIM Route Switching and ATIS*..... 39

 3.1.5 *Other MITSIM Behavioral Models* 39

 3.2 DYNAMIT..... 40

 3.2.1 *DynaMIT Network Representation* 42

 3.2.2 *DynaMIT Travel Demand*..... 42

 3.2.3 *DynaMIT State Estimation* 43

 3.2.3.1 *DynaMIT Demand Simulation*..... 43

 3.2.4 *DynaMIT Supply Simulation for Estimation*..... 48

 3.2.5 *DynaMIT Prediction*..... 48

 3.2.5.1 *DynaMIT Supply Simulation for Prediction* 49

 3.3 ATIS EVALUATION FRAMEWORK 50

 3.3.1 *ATIS Evaluation Methodology*..... 53

4 ATIS CASE STUDY: A SIMPLE NETWORK 55

 4.1 CALIBRATION RESULTS..... 56

 4.2 LOW DEMAND SCENARIO..... 58

 4.2.1 *Baseline Performance*..... 58

 4.2.2 *Sample Size Determination*..... 60

 4.2.3 *ATIS: User Performance* 61

 4.2.4 *ATIS: System Performance*..... 64

 4.3 HIGH DEMAND SCENARIO 66

 4.3.1 *Baseline Performance*..... 66

 4.3.2 *Sample Size Determination*..... 67

 4.3.3 *ATIS: User Performance* 67

 4.3.4 *ATIS: System Performance* 71

5 ATIS CASE STUDY: LOWER WESTCHESTER COUNTY..... 73

 5.1 NETWORK DESCRIPTION 73

 5.2 CALIBRATION RESULTS..... 74

 5.3 BASELINE PERFORMANCE 77

5.3.1	<i>No Incident</i>	78
5.3.2	<i>Incident</i>	78
5.4	ATIS PERFORMANCE	80
5.4.1	<i>Discussion of Results</i>	82
6	LESSONS FOR ATIS DEPLOYMENT	85
6.1	ATIS PROVIDERS AND CONSUMERS	85
6.1.1	<i>ATIS Supply and Demand</i>	86
6.1.2	<i>ATIS Technology Deployment</i>	89
6.1.3	<i>ATIS Taxonomy</i>	91
6.1.4	<i>Marketing ATIS</i>	93
6.2	ATIS PUBLIC INTERESTS	93
6.2.1	<i>ATIS System Performance</i>	94
6.2.2	<i>Distributional Considerations</i>	97
6.2.3	<i>Regional Evaluation</i>	98
7	CONCLUSION	99
7.1	THESIS CONTRIBUTIONS	100
7.2	SCOPE OF FUTURE RESEARCH	101
	APPENDIX A	103
	SOFTWARE OPERATION FOR THE ATIS EVALUATION FRAMEWORK	103

LIST OF FIGURES

FIGURE 1-1 TREPS ROLE IN THE NATIONAL ITS ARCHITECTURE (US-DOT 2003).....	17
FIGURE 2-1 REQUIREMENTS FOR DYNAMIC TRAFFIC MANAGEMENT EVALUATION BY SIMULATION.....	25
FIGURE 2-2 THE ORIGINAL MITSIMLAB EVALUATION FRAMEWORK.....	29
FIGURE 2-3 DYNAMIC TRAFFIC MANAGEMENT EVALUATION FRAMEWORK USING DYNAMIT	30
FIGURE 2-4 MODULAR ARCHITECTURE FOR DYNAMIC MANAGEMENT EVALUATION FRAMEWORK	31
FIGURE 3-1 DYNAMIC TRAFFIC MANAGEMENT EVALUATION FRAMEWORK USING DYNAMIT	34
FIGURE 3-2 MITSIM CLOCK-BASED OPERATION	36
FIGURE 3-3 ROUTE CHOICE EXAMPLE FOR MITSIM MODEL	38
FIGURE 3-4 OVERALL STRUCTURE OF DYNAMIT	41
FIGURE 3-5 DYNAMIT DEMAND SIMULATION.....	44
FIGURE 3-6 DYNAMIT PRE-TRIP CHOICE TREE	45
FIGURE 3-7 VARIABLES IN DYNAMIT PRE-TRIP BEHAVIORAL MODEL	46
FIGURE 3-8 A DYNAMIT ESTIMATION ITERATION.....	48
FIGURE 3-9 A DYNAMIT PREDICTION ITERATION	49
FIGURE 3-10 ATIS EVALUATION WITH MITSIM AND DYNAMIT.....	50
FIGURE 3-11 ATIS EVALUATION FLOWCHART	52
FIGURE 3-12 ATIS EVALUATION METHODOLOGY	53
FIGURE 4-1 SIMPLE NETWORK FOR ATIS EVALUATION.....	55
FIGURE 4-2 MEAN TRAVEL TIME VS. MARKET PENETRATION (LOW DEMAND).....	61
FIGURE 4-3 DISTRIBUTIONAL (GUIDED/UNGUIDED) MEAN TRAVEL TIME VS. MARKET PENETRATION	62
FIGURE 4-4 DEPARTURE TIME VS. TRAVEL TIME (LOW DEMAND, 50% GUIDED).....	64
FIGURE 4-5 TOTAL TRAVEL TIME VS. MARKET PENETRATION	65
FIGURE 4-6 MEAN TRAVEL TIME VS. MARKET PENETRATION (HIGH DEMAND)	68
FIGURE 4-7 DISTRIBUTIONAL (GUIDED/UNGUIDED) MEAN TRAVEL TIME VS. MARKET PENETRATION (HIGH DEMAND)	69
FIGURE 4-8 DEPARTURE TIME VS. TRAVEL TIME (HIGH DEMAND, 50% GUIDED).....	70
FIGURE 4-9 TOTAL TRAVEL TIME VS. MARKET PENETRATION (HIGH DEMAND)	72
FIGURE 5-1 DYNAMIT/MITSIM CALIBRATION RESULTS.....	75
FIGURE 5-2 MITSIM NETWORK REPRESENTATION AND INCIDENT LOCATION	77
FIGURE 5-3 DEPARTURE TIME VS. TRAVEL TIME NO INCIDENT LWC SCENARIO	78
FIGURE 5-4 DEPARTURE TIME VS. TRAVEL TIME INCIDENT LWC SCENARIO	79
FIGURE 5-5 DEPARTURE TIME VS. TRAVEL TIME, 30% GUIDANCE W/INCIDENT LWC SCENARIO	80
FIGURE 5-6 TOTAL TRAVEL TIME BY LWC SCENARIO.....	81
FIGURE 5-7 ATIS GUIDANCE QUALITY BY FACTOR	83
FIGURE 6-1 DEGRADATION OF MEAN TRAVEL TIME TO GUIDED DRIVERS	86
FIGURE 6-2 DEGRADATION OF AVERAGE TRAVEL TIME WITH INCREASING MARKET PENETRATION (FROM BALAKRISHNA, 2004).....	87
FIGURE 6-3 NATIONAL ITS ARCHITECTURE DYNAMIC ROUTE GUIDANCE MARKET PACKAGE	90
FIGURE 6-4 ATIS INFORMATION SPECTRUM (FROM BEINHAKR 2004)	92
FIGURE 6-5 POSSIBLE MISUSE OF ATIS	96
FIGURE 6-6 ATIS BENEFITS UNGUIDED DRIVERS AS WELL AS GUIDED.....	97



LIST OF TABLES

TABLE 2-1 SUMMARY OF TIME SAVED WITH ATIS24
 TABLE 2-2 BENEFITS OF ATIS FROM YANG ET AL. (1999)26
 TABLE 4-1 SIMPLE NETWORK CALIBRATION RESULTS57
 TABLE 4-2 INCIDENT/NON-INCIDENT BASELINE RESULTS59
 TABLE 4-3 TOTAL TRAVEL TIME BENEFITS UNDER ATIS65
 TABLE 4-4 INCIDENT/NON-INCIDENT BASELINE RESULTS (HIGH DEMAND)66
 TABLE 4-5 TOTAL TRAVEL TIME BENEFITS UNDER ATIS72
 TABLE 5-1 – LWC NY NETWORK CALIBRATION RESULTS76
 TABLE 5-2 SUMMARY STATISTICS FOR NO INCIDENT LWC SCENARIO78
 TABLE 5-3 SUMMARY STATISTICS FOR INCIDENT LWC SCENARIO79
 TABLE 5-4 SUMMARY STATISTICS FOR 30% GUIDANCE, INCIDENT LWC SCENARIO81
 TABLE 6-1 SIMPLE NETWORK HIGH DEMAND TOTAL TIME SAVINGS DUE TO INCIDENT95

LIST OF EQUATIONS

EQUATION 3-1 MITSIM PATH CHOICE LOGIT MODEL.....38
 EQUATION 3-2 MITSIM PATH SWITCHING LOGIT MODEL.....39
 EQUATION 3-3 DYNAMIT PRE-TRIP BEHAVIORAL MODEL.....47
 EQUATION 3-4 DYNAMIT PATH CHOICE LOGIT MODEL47
 EQUATION 4-1 ROOT MEAN SQUARE ERROR57
 EQUATION 4-2 ROOT MEAN SQUARE PERCENT ERROR57
 EQUATION 4-3 MEAN SIMULATION ERROR57
 EQUATION 4-4 MEAN PERCENT ERROR57
 EQUATION 4-5 SAMPLE SIZE DETERMINATION.....60

Chapter 1

1 Introduction

Intelligent Transportation Systems (ITS) is the application of computers, communications and sensor technology to surface transportation. Over the past ten years, the public and private sectors have invested billions of dollars in ITS research and development and in initial deployment of the resulting products and services (ITS America & US DOT, 2002). ITS technologies are being developed to improve the efficiency, productivity and safety of existing transportation facilities, to increase mobility, and to alleviate the impacts of transportation on the environment. A major component of American ITS investment has been in the field of Advanced Traveler Information Systems (ATIS), which, broadly defined, aim to provide better traveler information to drivers. Another major thrust of ITS investment, one which has historically been viewed as a distinct and separate effort from ATIS, has been in Advanced Transportation Management Systems (ATMS). “ATMS was initially directed towards creating a better-operating transportation network for all drivers”, whereas “ATIS was directed towards relatively affluent travelers who could afford to pay for special traveler information” (Sussman, 2003). Recently, however, there has been increased consideration given to the possibility that a properly designed and deployed traveler information system could allow travelers to make better travel decisions, *and in so doing* reduce travel time and increase trip reliability in the transportation system as a whole. ATMS, designed to constrain and control traffic, is naturally driven by *system optimal* objectives while ATIS, designed to influence demand, is driven by *user optimal* objectives. However, the system performance of a transportation network will generally be improved if drivers are better informed and consequently make better decisions (Ben-Akiva et al 2002).

To realize this potential, the Federal Highway Administration (FHWA) initiated a Dynamic Traffic Assignment (DTA) research project in 1994 to develop a sophisticated traffic

estimation and prediction system that could be integrated in a Traffic Management Center (TMC) and provide support for integrated ATIS and ATMS, among other ITS capabilities. The DynaMIT (Dynamic network assignment for the Management of Information to Travelers) application has been developed at MIT as part of this project, and is designed to be used in real-time operation for the provision of predictive route guidance; a form of ATIS.

This thesis has two parts. The first part describes the software development of an integration mechanism necessary to perform an evaluation of the effects of DynaMIT predictive route-guidance on transportation system performance. The second part of this thesis simulates transportation network performance under the provision of ATIS in various scenarios. The results hold implications to the overall significance of ATIS deployment, to the desired market structure for the ATIS industry, and to effective regulations that may be needed to derive maximum benefit from such services.

1.1 ATIS and Dynamic Route Guidance

Advanced Traveler Information Systems provide traffic information and travel recommendations and guidance to drivers to help them make better travel decisions. ATIS can be delivered through a variety of delivery mechanisms, including radio, World Wide Web, and on-board vehicle devices to name a few. Such systems differ from ATMS in that drivers are not obligated to follow the recommendations of the system. ATMS impose restrictions and constraints on traffic flows through mechanisms such as traffic lights, ramp metering, and lane-use signs. ATIS, in contrast, is designed to affect transportation demand by influencing the travel decisions of drivers.

The promise of ATIS lies in its potential to increase mobility and improve efficiency in existing transportation infrastructure. Recent surveys show that traffic congestion costs are staggering: £15 billion per year to the UK economy (Institute for Transportation Studies, 1999) and \$72 billion per year to the US economy (FHWA, 2001). The traditional approach to solving congestion is to build new infrastructure, but this may not be the best way – building roads is not only expensive and damaging to the environment, but also provides only temporary respite;

additional road capacity can lead to increased demand in the long run, and congestion recurs (Institute for Transportation Studies, 1999). Granted, in this situation of additional capacity there does exist a value-add to the economy as a whole since more traveler trips can be sustained, but the performance of the transportation network can still remain poor when trip length or reliability are considered. An alternate and hopeful solution is one that uses ATIS for better management of the existing infrastructure. Drivers using information from an ATIS could potentially make better travel decisions to reduce travel time and increase trip reliability, thereby benefiting both guided drivers as well as those without access to traffic information.

Dynamic route guidance is a specific kind of ATIS that reacts to current and changing traffic conditions. The generation of dynamic route guidance has provided new challenges to the transportation community. Historically, traffic simulation software has used static traffic assignment where vehicles behave according to equilibrium models of steady-state traffic. These applications, while extremely important in the transportation planning community, are inadequate for use in real-time route guidance applications because they are not able to capture the temporal or *dynamic* effects of traffic over time – information which is necessary to provide detailed real-time route guidance. Even detailed micro-simulation tools that do have the capability to show dynamic traffic behavior are too computationally intensive to be used in an online, real-time environment. These models typically incorporate detailed car-following, lane-changing and gap-acceptance models, but the high resolution needed to drive these models makes them unsuitable for the speedy processing of large transportation networks. There is therefore a need for a class of traffic simulators that can achieve sufficient precision, but that can also generate information to drivers before it is rendered obsolete.

Dynamic Traffic Assignment (DTA) systems refer to traffic simulation systems that are able to model the dynamic effects of traffic. There are two general classes of DTA systems – planning systems and real-time systems. DTA planning systems are intended to be useful to transportation planners, and are intended for use in various what-if scenarios to analyze the impact of infrastructure investment, major event planning and/or disruptions of regular operation. Academic examples include DynaMIT-P, DYNASMART-P. Real-time DTA traffic

simulation systems incorporate two additional capabilities: real-time processing, and demand estimation.

Generally speaking, real-time DTA systems are focused on trading off the high simulation detail associated with the computational requirements of microscopic simulators with the use of medium-resolution/medium-computational cost 'mesoscopic' traffic supply simulators. The benefit of this tradeoff is that DTA traffic simulations can, in 'real-time' (or in some operationally defined 'near-real-time') reflect current traffic conditions in a way that can be useful to drivers on the network. Real-time DTA systems are also concerned with *demand estimation* so that they can incorporate real-time traffic conditions to improve estimates and forecasts. Because of these capabilities, real-time DTA systems have been envisioned to be at the core of many different ATIS systems (FHWA, 2000). DynaMIT is one such DTA system (Ben-Akiva et al., 1996a), but others, like DYNASMART (Mahmassani and Jayakrishnan, 1992) are also being developed for various applications.

DTA technology is seen as filling the functional role of Traffic Estimation and Prediction Systems (TrEPS) in the US National ITS Architecture. The US Department of Transportation (DOT) has produced a National ITS Standards Architecture in an attempt to provide a common framework for planning, defining and integrating ITS. It is illustrative to consider the role of TrEPS in this architecture to provide context on the role of DTA systems within the larger ITS environment.

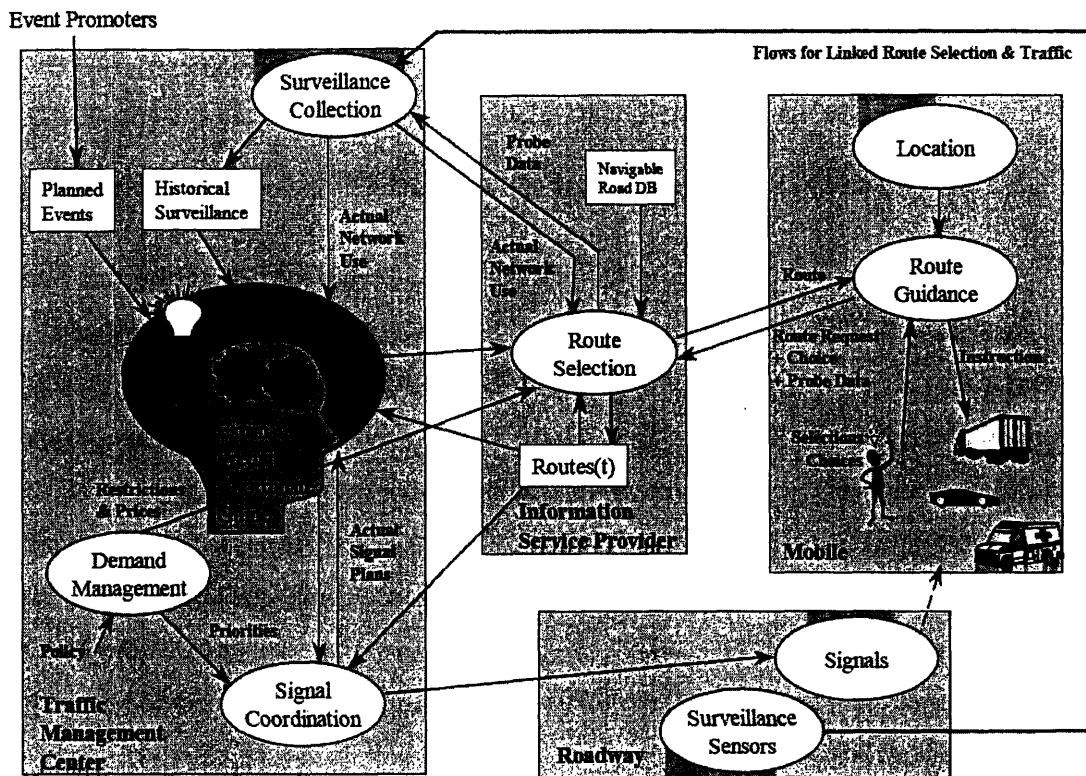

Figure 1-1 TrEPS role in the National ITS Architecture (US-DOT 2003)

Real-time DTA systems, when used for predictive route guidance, are part of an integrated intelligent transportation system that requires historical surveillance, network topology information, trip origin-destination data, and, of course, access to real-time surveillance information. In Figure-1, the National ITS Architecture illustrates a possible deployment scheme where a DTA system is operated within a publicly-managed Traffic Management Center. But there are many other likely scenarios in which private Information Service Providers (ISPs) may operate standard, proprietary or customized DTA systems on a per-subscriber basis. The National ITS Architecture view of DTA systems is also much broader than the focus of this thesis: As evidenced in the diagram above, the US DOT vision is that a TrEPS package will support a variety of applications – everything from route guidance to congestion pricing to emergency vehicle management and signal coordination. For the purposes of this thesis,

however, we are focused only on the effects of predictive route guidance on driver behavior, and not on the plausibility of using DTA simulations for other ATMS applications.

1.2 ATIS Policy and Evaluation of Route Guidance

The deployment of a dynamic route guidance system is expected to alter the performance of the surface transportation network where it is deployed. Hopefully the performance of the transportation network will be improved. But how can we measure these benefits? Conventional assessments focus on travel time savings under various guidance scenarios. By monetizing travel time we can achieve an economic measure of at least some component of dynamic route guidance benefits. Additionally, there is recent consensus in the transportation community that reliability in travel time estimates is also an important component of dynamic route guidance benefit (Sussman, 2003). While global estimates of travel time and reliability improvements are of importance, these metrics are more instructive when considered from the perspectives of various stakeholders.

Since the transportation network is a public resource, the effects of route guidance information will affect users of the network whether or not they are directly involved in the production or consumption of route guidance information. An evaluation of the effects of route guidance, then, must consider the perspectives of various stakeholders. For the purposes of discussion in this thesis, we will consider four main stakeholders:

1. **Public Entities / US DOT:** Governmental interests are focused on maximizing the efficient operation of the underlying network. Public interests are also sensitive to any distributional effects that may occur under the provision of route guidance.
2. **Guided Drivers:** Guided drivers are active users of dynamic route guidance information, and while they may or may not have made a conscious decision to subscribe to such a service, they are able to incorporate guidance into their route choices.

3. **Unguided Drivers:** Unguided drivers do not have access to dynamic route guidance information, and will make route-choice decisions based on publicly available information only. (eg. Radio broadcasts, road-side Vehicle Message Signs (VMS))
4. **ATIS Provider/ISP:** Dynamic route guidance Information Service Providers (ISPs) are profit-maximizing entities that sell route guidance information.

An evaluation of the effects of dynamic route guidance, then, should consider the effects of information on each of these stakeholders. First and foremost, local, state and national transportation planning agencies will be interested in gaining a better understanding of what the expected benefit of route guidance deployments will be. If we can expect that route guidance system deployments will show substantial economic benefit in terms of monetized travel-time and/or increased reliability, then perhaps public entities will be more willing to spend funds traditionally allocated towards infrastructure development on ATIS applications. At the very least, if benefits from route guidance systems can be demonstrated at the local level, then this will likely help foster the public/private partnerships that are so challenged in this field (Sussman, 2003).

Second, an evaluation of dynamic route guidance should provide estimates of transportation network performance benefits to both guided and unguided drivers. If, for instance, travel time and travel time reliability are degraded for unguided drivers while guided drivers benefit, then perhaps dynamic route guidance should simply be viewed as a proxy for other forms of tolls; eg. if you pay more you can derive certain benefits that others cannot (ie. use of a private road). Alternately, if dynamic route guidance improves travel time and reliability metrics for all drivers, then perhaps a free public service becomes feasible, or perhaps public interests can put aside concerns about the regulation of private ISPs.

Third, assuming that there is some correlation between perceived travel time benefits to drivers and willingness to pay (this relationship itself is an open research question), a better understanding of these benefits may allow private ISPs to develop market entry plans and determine which regions of the US would support their business.

Finally, recognizing that dynamic route guidance is an information-based product, the ATIS service provider industry will have high fixed costs as compared with variable costs, and will have many incentives to increase market penetration once they have built up their ATIS infrastructure. How will this marketing pressure affect the quality of service? What, if any, regulations will be needed to ensure optimal benefit?

These lessons, and others, from the ATIS evaluations conducted in this thesis will be taken up in Chapter 6.

1.3 Motivation and Thesis Objectives

Effective public and corporate policy for the successful deployment of dynamic route guidance hinge on an accurate understanding of the effects on the transportation network. But the effects of dynamic route guidance can vary significantly over many different factors including network topology (ie. available alternate paths, incidents), socioeconomic characteristics of driver population (ie. market penetration of guidance), and travel demand. Therefore, there is a need for an evaluation framework to evaluate what-if scenarios before incurring the significant investment costs of developing field-testing real implementations. This is the first motivation for this thesis research - to develop a fully-functional software integration that allows the DynaMIT real-time DTA system to be evaluated in 'closed-loop' operation with a ground-truth simulator. In such a system the DTA system is operating in an integrated fashion with either a real Traffic Management Center or a ground-truth simulator.

The motivation for a software framework for ATIS evaluation is to allow analysts to:

- Assess the quality of estimation and prediction capabilities of DTA systems, using real operational data, and the performance of various models used in the system against real data
- Assess the benefits and applicability of the outputs generated from these systems as a prelude to full-scale field deployment at private traffic ISPs or public Traffic Management Centers (TMCs)

- Assess the efficiency and real-time performance of the system and make required performance improvements

Ben-Akiva et al. (1996b) proposed the applicability of MITSIMLab (Microscopic Traffic Simulation Laboratory) as a suitable simulation laboratory for the evaluation of dynamic traffic management systems. The first main research objective, then, is to integrate DynaMIT with MITSIMLab for the ‘closed loop’ simulation applications described above. Furthermore, software components of the DynaMIT / MITSIMLab ATIS Evaluation Framework can be re-used for integration of DynaMIT with real-world applications.

The second motivation for this thesis research is to use the capabilities of the DynaMIT / MITSIM ATIS Evaluation Framework to evaluate the effects of the provision of dynamic route guidance in various case studies. While there have been many reports on the effects of route guidance, the specific benefits that accrue from such a service is sensitive to the area of deployment as well as the nature of the information. For example, the effectiveness of instantaneous or real-time information is different from DynaMIT predictive information, just as information from another type of prediction mechanism would be. Therefore, the results from these case studies will offer new information for both public planners as well as private ATIS entrepreneurs in the area.

1.4 Summary of Results

The ATIS Evaluation Framework developed as part of this thesis is applied to two case studies – the first is a simple network with hypothetical travel demand, the second is a network of Lower Westchester County, New York. Results from the simple network confirm many results in the ATIS literature. First, the provision of DynaMIT predictive ATIS improves network performance by allowing drivers to make better informed route choice decisions. Second, the provision of DynaMIT ATIS results in simultaneous performance benefits to both guided and unguided drivers. Finally, while the provision of DynaMIT ATIS may result in an

overreaction¹ phenomenon, this need not necessarily be the case. The result of overreaction is a function of the network topology, demand, information update interval and market penetration of ATIS.

Results from the Lower Westchester County, NY case study illustrate the sensitivity of DynaMIT ATIS performance to various factors including surveillance coverage, information update interval, DynaMIT computational resources, and model calibration. Based on the analysis we suggest direction for future work on this network.

1.5 Thesis Outline

This thesis proceeds as follows. Chapter 2 summarizes the literature concerning the various methodologies that can be used to evaluate the impact of dynamic route guidance on the transportation network. The literature review also summarizes some of the work that has been done to interface Dynamic Traffic Assignment systems with Traffic Management Centers and/or ground-truth simulators. Chapter 3 describes the development and operation of the ATIS Evaluation Framework - the integration between DynaMIT and MITSIM. Chapter 4 discusses ATIS simulation results from a detailed case study on a simple network. Chapter 5 presents results from a simulation on the Lower Westchester County (LWC), NY network. Chapter 6 offers lessons for ATIS deployment and answers the questions posed in section 1.2.

¹ See page 25 for definition.

Chapter 2

2 Literature Review

This literature review is in two parts. The first part considers prior evaluations of ATIS performance, and discusses how these results have guided the experimental design in this thesis. The second part of this literature review discusses prior contributions to develop ATIS evaluation frameworks using the DynaMIT and MITSIM software.

2.1 Evaluation of ATIS

While this thesis focuses on evaluation of a specific kind of ATIS – dynamic route guidance – there have been many studies describing the impact of many kinds of ATIS on the performance of transportation networks. Some of these earlier studies hold important lessons on the impact of route-guidance information. Most of these studies motivate the need for dynamic route guidance. This section presents prior work done to quantify the impact of ATIS on transportation network performance, including a discussion of proper metrics and sensitivity analyses that have been incorporated into the experimental design in the analysis performed later in this thesis.

Levinson, et al. (1999) summarized a number of contributions concerning the impact of ATIS. See Table 2-1.

Summary of time saved with ATIS by study

Author	Congestion level/type	Time saved (%)	Market share (%)
Adler et al. (1999)	Free flow (800 vph)	2.7	100
	Congestion (1500 vph)	3.1	80
Wunderlich (1996)	Rain (25% drop in overall capacity)	12	10
	Construction (50% drop in capacity locally)	18	10
	Incident (50% drop in capacity locally)	6	10
Emmerink et al. (1996a,b)	Recurrent congestion	1-4	100
Emmerink et al. (1995a,b,c)	Recurrent congestion	7	
Wunderlich (1995)	Congestion but not reaching saturation	8-20	5
	Saturation	7-12	5
Wunderlich (1995)	Capacity-reducing incident	15	
Al-Deek and Kanafani (1989)	Difference in SO and UE	3-4	
Al-Deek and Kanafani (1993)	Modeling of incident conditions	30-40, 25-55	
STORM, Stuttgart, Germany, (Peckmann, 1996)	Field operational test simulation	20	
Inman and Peters (1996)	Field operational test simulation	5	10
		8	30
		11	50

Note: Time saved overall or *equipped vehicles only*.

Reference: Levinson et al., 1999.

Table 2-1 Summary of Time Saved with ATIS

What is most striking about this compilation of ATIS results is the wide variation between the studies. Time saved varies from 2.7% to 55%. The table holds a partial explanation – the market penetration of ATIS varies across these studies. But that is not all. Each of these studies uses different underlying network topologies, different demand characteristics, and different types of guidance. This table serves to illustrate the widely varying perception of the impact of ATIS, and provides an indication as to why it is extremely difficult to compare ATIS results across the board.

Levinson (1999) goes on to conduct his own simple probabilistic queuing model to determine the impact of ATIS on a simple network. The nature of the ATIS in this study is predictive, in the sense that guided drivers receive information about the expected travel time on downstream links based on the number of drivers ahead of them, using a queuing model whose throughput declines in incident situations. Levinson confirms some basic findings in this area: 1) that ATIS can provide benefits to both individuals and to society, 2) that ATIS is most effective in non-recurrent congestion situations, 3) that under recurrent congestion situations ATIS provides little benefit in under-saturated or grossly over-saturated demand conditions.

Wunderlich et al. (2001) conducted a study from the Washington, D.C. Metropolitan Area that suggests that the benefits of ATIS are best described as time-management benefits. Wunderlich found that even though in-vehicle travel time was not significantly reduced under an ATIS scenario, the on-time reliability of guided drivers was improved. He also devised a methodology for estimating benefits associated with time management improvements.

Simulation has been used extensively to study the performance of dynamic route guidance systems. Ben-Akiva et al. (1995) identified the different requirements for evaluating Dynamic Traffic Management Systems using simulation:

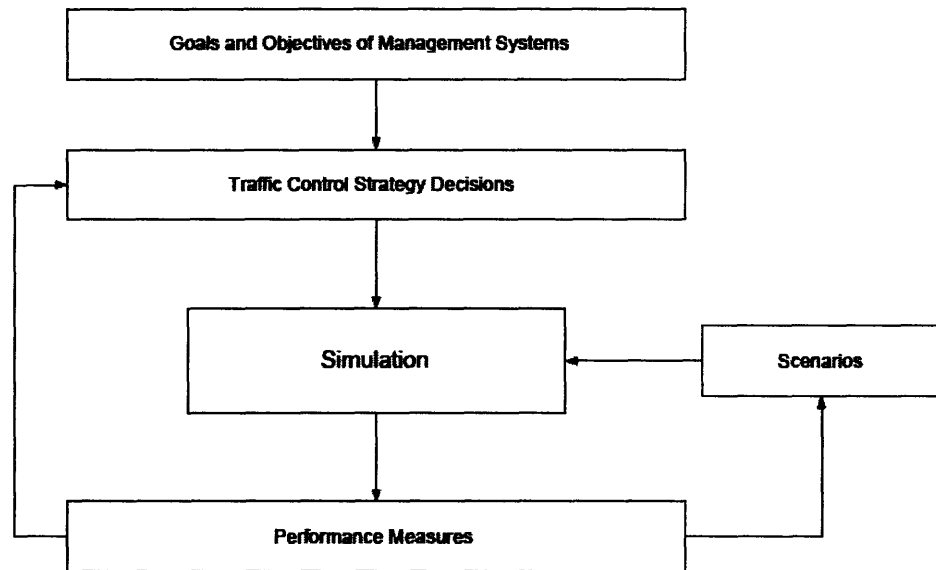

Figure 2-1 Requirements for Dynamic Traffic Management Evaluation by Simulation

Source: Ben-Akiva et al. (1995)

Results from simulation-based analyses on small networks have confirmed the need for prediction-based guidance (Ben-Akiva et al 1991, Kaysi 1992, Ben-Akiva et al 1996, Yang et al 1999). The results from Yang et al. (1999) showed the benefits from predictive information in the form of saved travel time. This is the most conventional measure of effectiveness of the provision of ATIS. Results based on a case study from a 309 link road network on the A10 Beltway in Amsterdam, The Netherlands, showed the benefits of predictive guidance vs. naïve guidance. The information classes were defined as follows:

- *No Real Time Information* – All drivers use habitual routes, based on time-variant historical travel times.
- *Naïve Information* – Every 5 minutes drivers evaluate their paths using the latest link travel times.
- *Predictive Information* – Every 15 minutes the system predicts traffic conditions for the next 45 minutes. Only 30% of drivers - ‘guided’ drivers – had access to the predictive information for route-choice decisions.

These results of an incident scenario (non-recurrent congestion) are summarized in Table 2-2.

Driver Group	OD Pairs	w/o Guidance minutes	w/ Guidance	
			Naive change (%)	Predictive change (%)
Informed	8-14	14.7	-7.8	-2.3
	8-18	18.9	-7.1	-9.4
	8-1	20.9	-16.6	-15.5
	11-14	5.8	38.3	29.6
	11-18	9.0	33.1	22.4
	11-1	17.8	-19.0	-17.6
Un-informed	8-14	14.7	-9.3	-4.2
	8-18	18.9	-5.5	-3.7
	8-1	20.9	-14.0	-17.4
	11-14	5.8	41.1	28.9
	11-18	9.0	30.6	21.0
	11-1	17.8	-11.8	-9.7

Table 2-2 Benefits of ATIS from Yang et al. (1999)

Source: Yang et al. (1999)

Results from Yang et al. (1999) show the benefits of naïve ATIS (~2-3% of travel time).

The results also demonstrate the benefits of predictive ATIS in dealing with the problem of *overreaction*. Overreaction describes the situation in which drivers overcompensate in response to information, again causing sub-optimal traffic conditions. Kaysi (1992) discussed the sensitivity of overreaction to market penetration and information update interval, and found through simulation that overreaction became

apparent at market penetration levels above 50%. Kaysi also noted information update intervals longer than 2.5 minutes exacerbated the observed overreaction phenomena.

Predictive ATIS can account for this phenomenon and represent this effect in forecasted travel times. In the predictive ATIS scenario presented by Yang et al. (1999), predictive ATIS did not differ significantly from naïve ATIS for OD pairs that experienced a travel time benefit from guidance, but, by compensating for overreaction, predictive ATIS did significantly reduce the travel times on OD pairs whose travel times increased. Another important result from this study was that, while unguided drivers also saw benefit under ATIS scenarios, their share of the benefit to travel time was significantly less than the guided drivers. (Yang et al., 1999).

The literature is fairly consistent that the provision of information has the potential to reduce congestion. A distinction is commonly made between *recurrent* congestion which occurs on a periodic basis (eg. daily rush hours) and *non-recurrent* congestion which is due to unforeseeable incidents (eg. accidents) that are not incorporated into conventional wisdom. Past studies have concluded that the provision of information holds the most benefit in cases of *non-recurrent* congestion.

Balakrishna et al. (2004) investigated the sensitivity of ATIS to three parameters: frequency of information update, penetration rate of information sources and demand prediction error. This study applies an updated version of the framework presented by Yang et al. (1997) to a 211 link network of the Central Artery/Tunnel network in central Boston, MA. The results showed:

1. Higher update frequencies reduced travel times, with the greatest marginal impact between 5 minute and 15 minute information update intervals. Update intervals longer than 15 minutes degraded travel time benefit slowly, while more frequent updates than 5 minutes also had only marginal effect.
2. Guidance penetration rate improved travel times only to 70% market penetration. Beyond this level of ATIS deployment travel time performance benefits were degraded. Balakrishna explains this phenomenon as a manifestation of overreaction.

3. Demand prediction errors reduced benefits of ATIS in both overestimation and underestimation of demand predictions.

2.1.1 Summary

The literature review holds implications for experimental design of the ensuing case studies. First, we expect to confirm that the provision of DynaMIT ATIS benefits both guided and unguided drivers, with the lion's share of benefits attributed to guided drivers. Second, we expect to see some evidence in overreaction when the market penetration of ATIS becomes sufficiently high. Finally, while absolute travel time is an important measure of effectiveness of ATIS, we should also consider trip reliability in the discussion.

2.2 Evaluation Frameworks for DTA Systems

Literature concerning the interface of Dynamic Traffic Assignment Systems with the Traffic Management Center, or with ground-truth simulators, is quite limited because the integration required can be specific to the actual DTA system being used.

Yang et al (1999) presented a framework to realize the ATIS/ATMS evaluation methodology presented below, in Figure 2-2. The framework was an integrated simulation environment that can model the interaction effect of ATIS information and/or ATMS control systems. The framework uses MITSIM, a microscopic traffic simulator, that models traffic flows in the network at the vehicle level, including the impact of descriptive² information on driver behavior. The framework also used a Traffic Management Simulator (TMS) component that was used to generate the traveler information under evaluation. The traffic information generated in the TMS was fed into MITSIM to capture its effect on driver behavior. The changes in traffic flows were measured by the MITSIM surveillance system and reported in a variety of formats that allowed access to simulated sensor counts, travel times, path summaries and aggregated

² *Descriptive* information provides the driver with descriptions of current or future traffic conditions, and leaves the actual choice of route to the driver. Alternatively, *prescriptive* information recommends a particular route, with some fraction of drivers complying with the system's recommendation.

‘measures of effectiveness’ reports. Figure 2-2: illustrates the framework. Please see Yang et al. (1999) for a detailed discussion of the guidance generation procedure used in the TMS component.

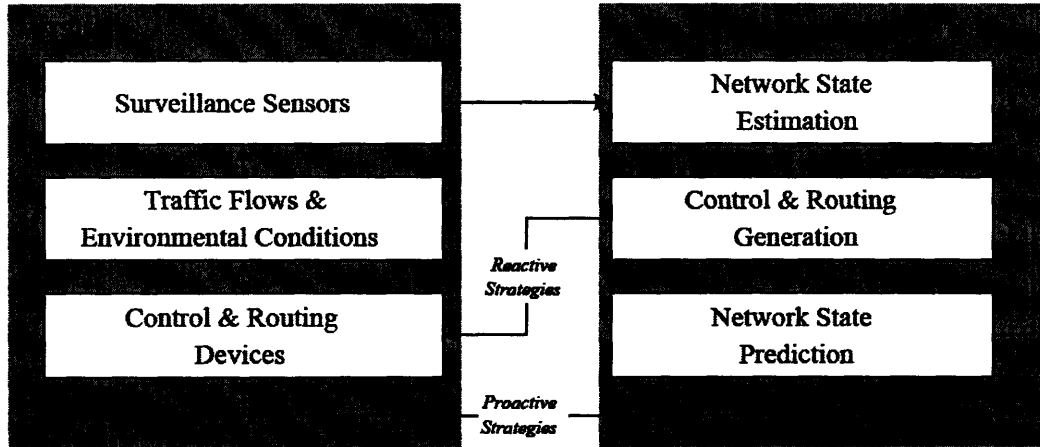

Figure 2-2 The Original MITSIMLab Evaluation Framework

Source: Yang (1999)

Ben-Akiva et al (2000) replaced the TMS component with a more sophisticated Dynamic Traffic Assignment system. DynaMIT is a simulation-based real-time system designed to estimate the current state of a transportation network, predict future traffic conditions, and provide consistent and unbiased information to travelers. DynaMIT generates *unbiased* information, which means that the information generated is based on the best available knowledge of future network conditions. DynaMIT also generates *consistent* information, which means that the network conditions experienced by any traveler coincide with the predicted conditions on which the information was based. DynaMIT information reflects *user optimality* in the sense that the information is aimed at optimizing travelers’ utilities, of which the main components are travel time in the network and schedule delay. This updated evaluation framework again uses MITSIM as a ground-truth simulator, to server as a full “true” representation of the real world. The “true” demand is obtained from habitual travel demand, combined with the simulation of drivers’ response to pre-trip information. The surveillance system again consists of virtual sensors modeled in the MITSIM road network. The behavior models in DynaMIT

are an approximation of the behavior represented in MITSIM. The new framework is shown in Figure 2-3.

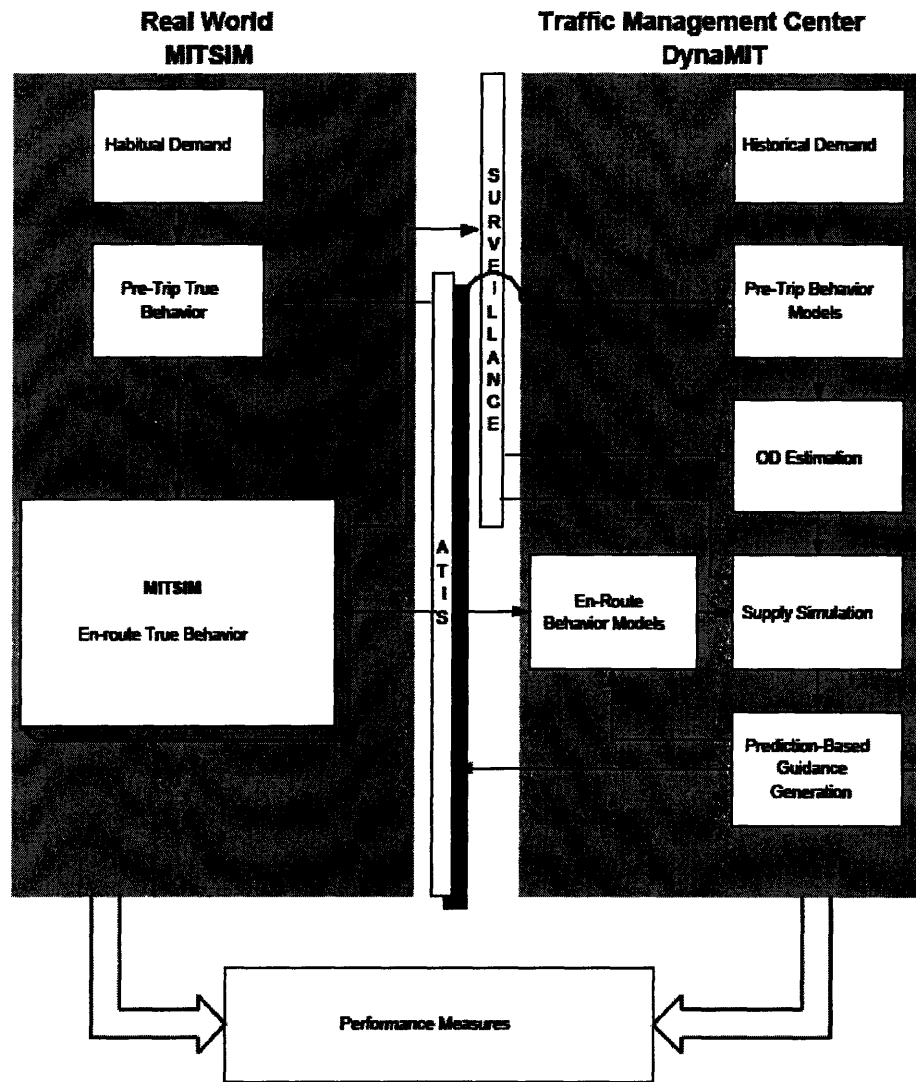

Figure 2-3 Dynamic Traffic Management Evaluation Framework using DynaMIT

Source: Ben-Akiva et al. (2000)

Mehta (2001) developed a more sophisticated interface for the integration of DynaMIT with a Traffic Management Center using a CORBA (Common Object Request Broker Architecture) framework. The CORBA framework is an object-based middleware software that allows disparate systems to communicate via a software

language-neutral Application Programming Interface (API). The modular architecture for the evaluation laboratory is shown in Figure 2-4.

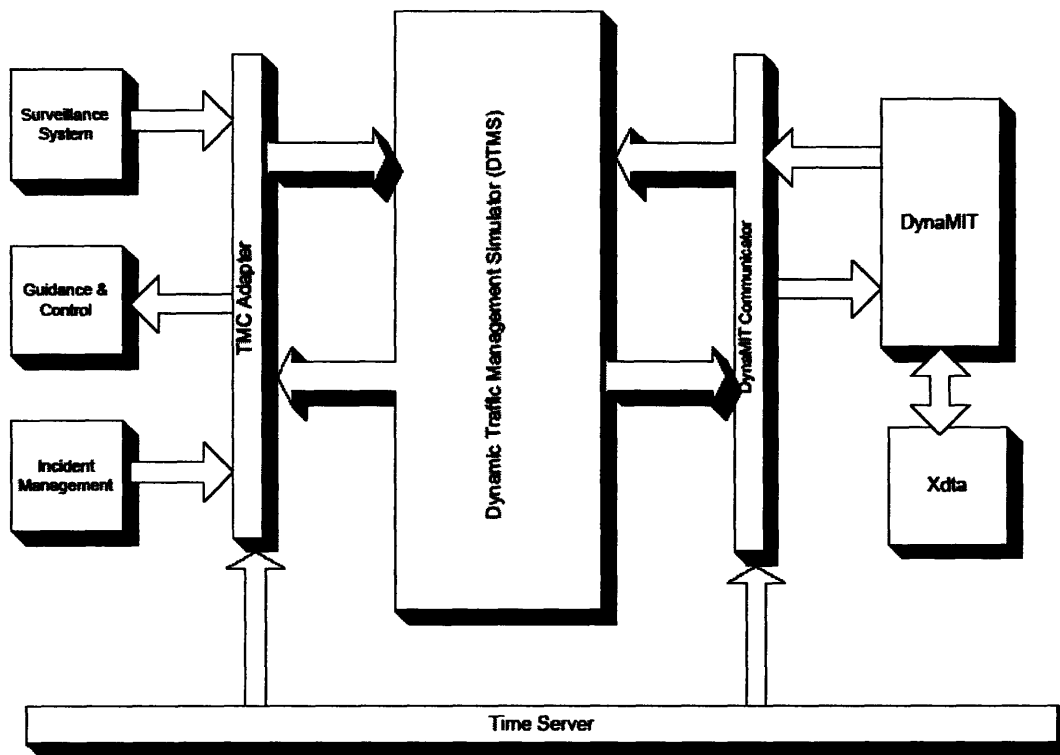

Figure 2-4 Modular Architecture for Dynamic Management Evaluation Framework

Source: Mehta (2001)

Mehta's architecture was comprehensive in scope; it included integration capabilities for control data for the incorporation and evaluation of ATMS. This architecture was a modular attempt to reduce the system integration effort of DynaMIT with TMCs, but it required a substantial amount of system administration resources that are cumbersome for simpler applications. Nevertheless, many of the fundamental interactions between DynaMIT and the TMC have been captured in Mehta (2001).

Chapter 3

3 Development of a Software Interface for ATIS Evaluation using DynaMIT

This chapter presents an ATIS evaluation framework using the DynaMIT dynamic traffic assignment software package and the MITSIM microscopic traffic simulator. The overall functionality and operation of the system is presented alongside a description of the relevant functional components of both the DynaMIT and MITSIM simulation software. The reader is referred to Appendix A for operating documentation for the evaluation framework.

3.1 Overview

In order to evaluate the effects of ATIS generated from the DynaMIT dynamic traffic management system we require either:

- a) DynaMIT field deployment at a TMC or private transportation ISP for real-time information provision to drivers, or
- b) DynaMIT integration with a ‘ground-truth’ simulator that can reproduce the effects of ATIS during simulation.

The ATIS evaluation framework presented here uses MITSIM as a ground-truth simulator in lieu of an actual field deployment. The overall evaluation framework is similar to that presented in Figure 2-3, and is included again here for ease of reference. During real-time operation of the ATIS evaluation framework, MITSIM provides DynaMIT with surveillance reports (ie. sensor counts) of simulated ‘real world’ traffic flows. Just as it would in a real-world scenario, DynaMIT uses the surveillance report to perform consistent demand estimations and to generate unbiased guidance predictions. These guidance forecasts are relayed to MITSIM for dissemination to simulated drivers. The results of the MITSIM simulation are representative of what would occur in reality,

and any relevant measures of effectiveness available in the MITSIM reporting capabilities can be used as a basis for an ATIS evaluation.

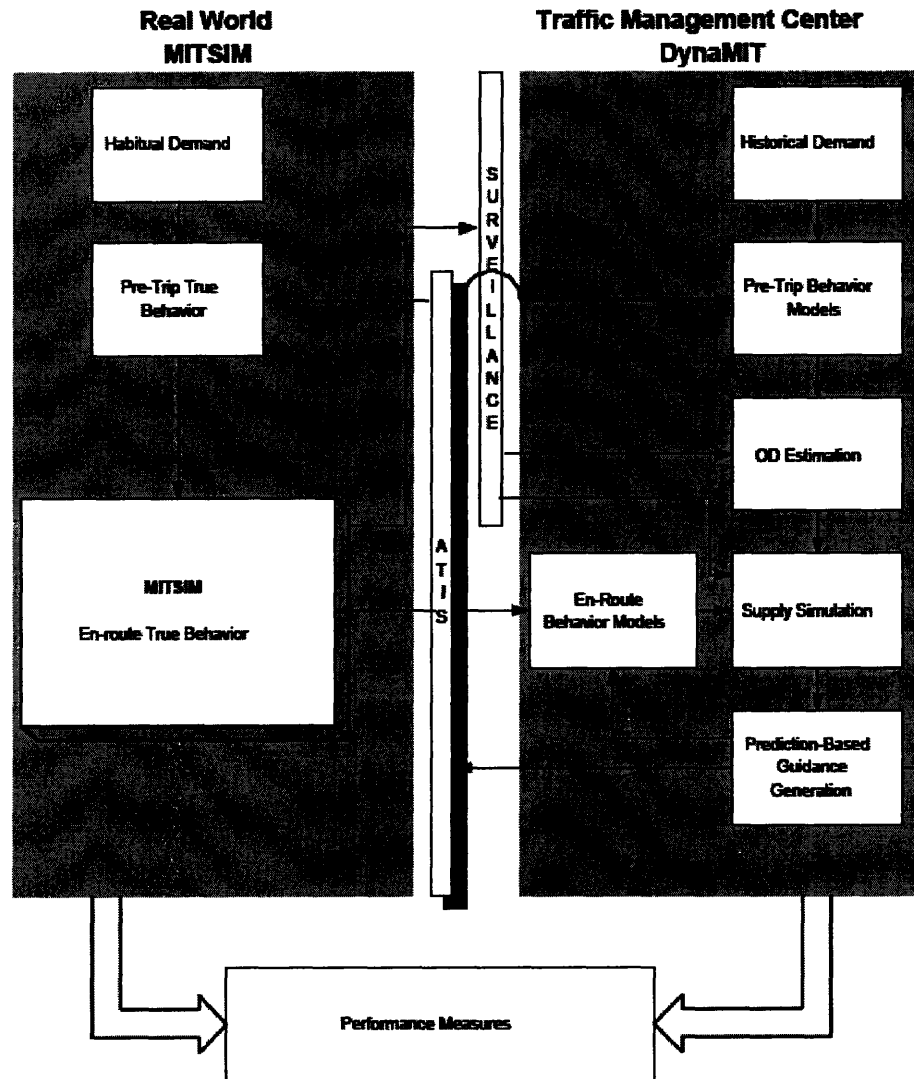

Figure 3-1 Dynamic Traffic Management Evaluation Framework using DynaMIT

Source: Ben-Akiva et al. (2000)

The MITSIM microscopic traffic simulator plays the same role in the ATIS evaluation framework as it does in the MITSIMLab framework (Yang et al., 1999). The MITSIMLab framework consists of a traffic flow simulator (MITSIM) and a traffic management system (TMS). MITSIM models traffic flows in the network at the vehicle level, including driver behavior, while TMS added functionality to disseminate traveler

information to drivers loaded on a MITSIM network. In this new ATIS evaluation framework, however, the TMS has been replaced with DynaMIT, a much more sophisticated guidance generation package. MITSIM is able to simulate the real world through its realistic models for network representation (topology, incidents), route choice, and vehicle advancement (acceleration models, lane changing models). The reader is referred to Toledo (2003) for a thorough treatment of MITSIM traffic models.

Figure 3-2 below, from Yang (1993) shows the overall operation of the MITSIM clock-based simulation.

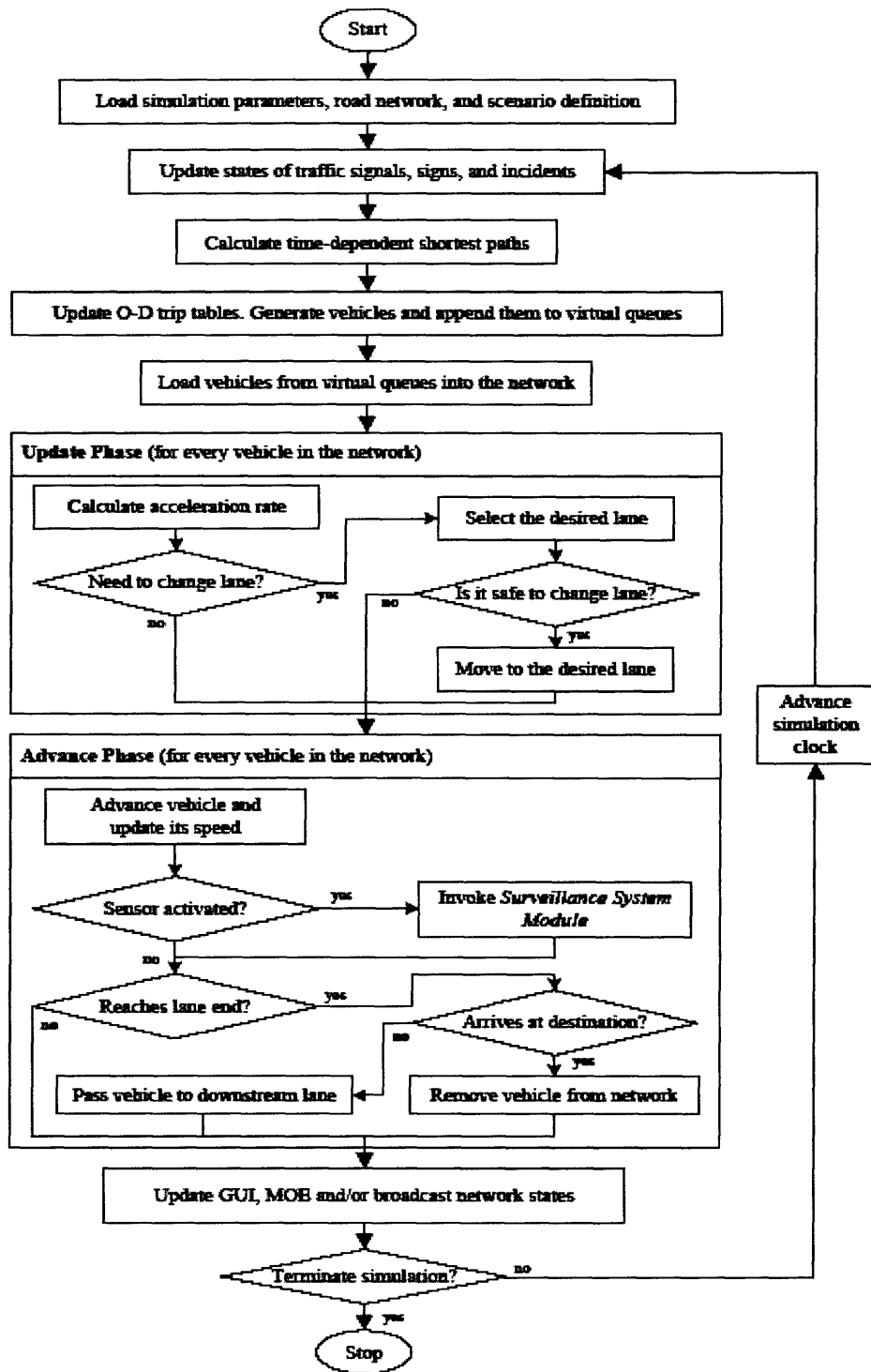

Figure 3-2 MITSIM Clock-Based Operation

Source: Yang (1993)

3.1.1 MITSIM Network Representation

MITSIM represents road networks with nodes, links, segments and lanes. This allows analysts to monitor performance at an extremely fine level of resolution. As well, the MITSIM network representation allows for the placement of sensors within lanes in the network.

Incidents can be placed on any lane within the network, and can be placed and/or cleared at any time. Since ATIS is especially useful in cases of non-recurrent congestion (eg. incidents), MITSIM's ability to model the visibility, number of lanes affected, location, severity and duration of an incident is extremely powerful. Because the incident may begin before it is reported to the ATIS service, this allows for the evaluation of various incident detection schemes.

3.1.2 MITSIM Travel Demand

MITSIM represents demand as *time dependent* OD tables, and loads vehicles onto the network according to a Poisson distribution based on parameters specified in the OD descriptions. MITSIM specified vehicle performance characteristics (eg. Maximum acceleration, speed) are specified deterministically, while driver behavior parameters are assigned randomly according to specified distributions. With specific regards to route-choice decisions in response to traffic information, MITSIM assumes two distinct driver groups: *uninformed* drivers have access to historical travel time tables - this represents a 'conventional wisdom' of travel times – while *informed* drivers have access to travel time tables that, in this ATIS evaluation framework, are updated according to newly received predictive guidance from DynaMIT.

Note: In the ATIS evaluation framework, the MITSIM travel demand represents the real-world demand. By experimental design this will be different from the historical OD representation used in DynaMIT since real-world demand will always slightly different from historical estimates.

3.1.3 MITSIM Route Choice and ATIS

Routes for MITSIM vehicles without pre-specified paths are calculated at each intersection using a *route-choice model* see Fig. 3.3:

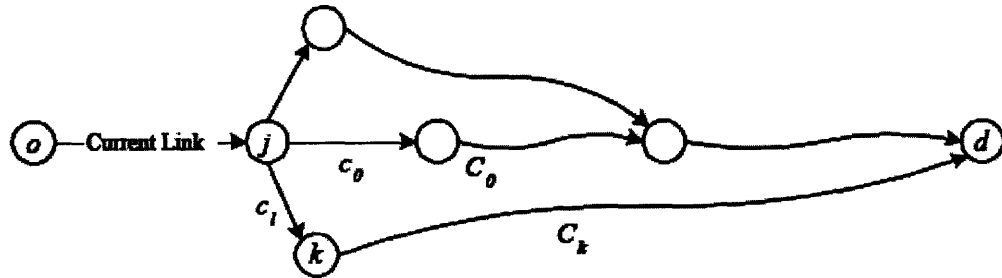

Figure 3-3 Route Choice Example for MITSIM model

The model is:

$$p(l|j,t) = \frac{\exp(V_l(t))}{\sum_{m \in L_j} \exp(V_m(t))}$$

Equation 3-1 MITSIM Path Choice Logit Model

where:

$p(l|j,t)$ = probability to choose link l for a vehicle that expects to arrive at node j at time t ;

L_j = set of outgoing links at node j ;

$V_l(t)$ = systematic utility of choosing a route with link l as the next link.

In the default model, the utility is a function of:

$c_l(t)$ = perceived travel time on link l at time t ;

$C_k(t)$ = perceived travel time on the *shortest path* from node k (the downstream node of link l) to the destination if the vehicle arrives at node k at time t ; and

z_l = penalty that captures freeway bias.

The perceived travel times $c_l(t)$ and $C_k(t)$ are time dependent, and are calculated from either historical travel-times or guided travel-times. Thus, $p(l|j,t)$, the route choice probability, will differ among *informed* and *uninformed* vehicles, even for vehicles expecting to arrive at the same node j at the same time t .

3.1.4 MITSIM Route Switching and ATIS

Even though vehicles in MITSIM may be configured with pre-assigned paths so that they do not choose paths at each intersection, the provision of new ATIS in MITSIM triggers the route switching model for *informed* drivers. The route-switching model is:

$$p(s|r, t) = \frac{\exp(V_s(t))}{\sum_{i \in S_r} \exp(V_i(t))}$$

Equation 3-2 MITSIM Path Switching Logit Model

where:

$p(s|r, t)$ = probability to choose path s for a vehicle that expects to arrive at the decision node at time t using path r ;

S_r = set of available paths from node j to the driver's destination;

$V_i(t)$ = systematic utility of choosing path i which is a function of:

$C_i(t)$ = expected time on path i at time t ; and,

$Z_i(t)$ = diversion penalty if path i is different from the driver's current path r

3.1.5 Other MITSIM Behavioral Models

MITSIM also incorporates detailed acceleration models (ie. car-following models, free-flowing and emergency regimes, merging rules, and incident-response behavior) as well as lane-changing models (ie. gap acceptance, nosing models) to accurately simulate driver behavior. These models are not discussed here because the provision of ATIS does not directly affect these behaviors. Again, the reader is referred to Toledo (2003) for a thorough treatment of MITSIM traffic models.

3.2 DynaMIT

DynaMIT is a simulation-based real-time system designed to estimate the current state of a transportation network, predict future traffic conditions, and provide consistent and unbiased information to travelers. DynaMIT combines real-time data from a surveillance system with historical travel time data in order to predict future traffic conditions and provide travel information and guidance through an ATIS. Although model errors within DynaMIT mean that it is not a perfect reflection of reality, the information that DynaMIT generates is:

- Unbiased – The information provided to any traveler is based on the best knowledge of future network conditions that is available
- Consistent – The network conditions experienced by travelers coincide with the predicted conditions on which the information was based

Therefore, a travel choice inferred from DynaMIT information will “not be inferior to other network conditions as they develop.” (Ben-Akiva et al, 2002)

The overall structure of DynaMIT is shown Figure 3.4. For a detailed discussion of DynaMIT, please see Balakrishna (2002). The state estimation module gives the current estimate of the network in terms of O-D flows, speeds, densities, queues and link flows, using the inputs (sensor counts etc.) from the network. The State Estimation module has two main models: (1) The Demand Simulator, and (2) The Supply Simulator. The Demand Simulator has the capability to do real-time O-D estimation, taking into account user behavior for route, departure time and mode. It also models the impact of information by maintaining two separate travel time tables for guided and unguided drivers. The O-D model then uses the real-time sensor counts, updated O-D flows, and assignment matrices (fraction of OD flows to link flows) to estimate the current interval O-D flows. The Supply Simulator simulates the traffic conditions over the network using the estimated O-D flows from the Demand Simulator, updated capacities (due to incidents etc.), traffic dynamic parameters, and ATIS guidance. Response of users to ATIS is captured through the pre-trip and en-route driver behavior models.

The Prediction-based Guidance Generation module generates predictive guidance. An iterative framework is used to obtain *consistent* guidance, which means that route-

choice decisions inferred from this guidance will result in optimal³ path decisions for each driver. Each iteration consists of a trial strategy and network state prediction (both demand and supply prediction) under the strategy and an evaluation of the predicted state for consistency.

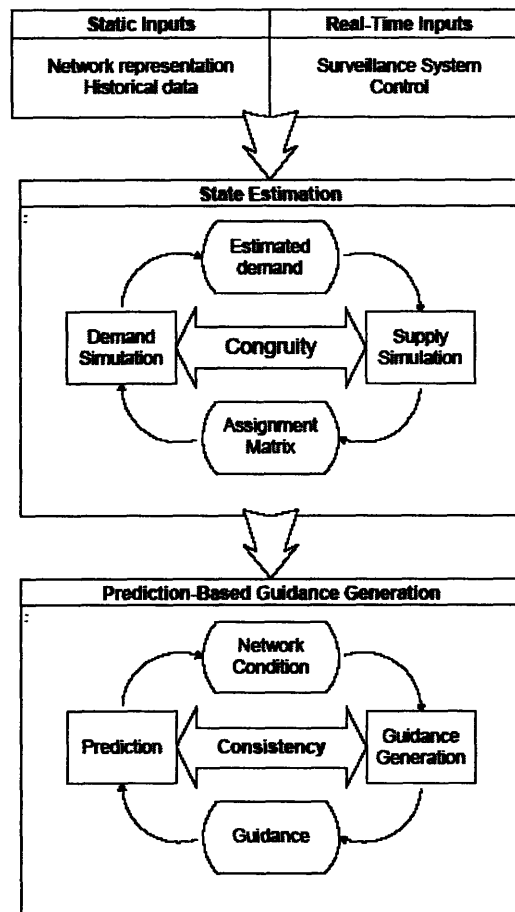

Figure 3-4 Overall Structure of DynaMIT

Source: Ben-Akiva et al. (2000)

³ Optimal here refers to *user optimal* traffic assignment conditions in which no driver can reduce their travel time by switching routes. Note that *user optimal* and *system optimal* are two distinct cases. DynaMIT guidance will result in approximations of a *user optimum*. Its effect on *system optimality* is discussed later in this thesis.

3.2.1 DynaMIT Network Representation

Like MITSIM, DynaMIT represents road networks with nodes, links, segments and lanes, and allows the analyst to place sensors within segments in the network. However, there are two key differences between the DynaMIT and MITSIM network representations:

1. DynaMIT maintains network supply characteristics separately from the network topology, whereas MITSIM models supply from the physical specifications of the network.
2. DynaMIT incidents are placed on a segment of road (segments may contain multiple lanes) whereas MITSIM incidents are placed on one or more specific lanes within a segment.

These discrepancies are important considerations in the integration of DynaMIT with MITSIM, and will be discussed later.

As with MITSIM, incidents can be placed on any lane within the network, and can be placed and/or cleared at any time.

3.2.2 DynaMIT Travel Demand

DynaMIT represents habitual travel demand as *time dependent* OD tables. (Note: While DynaMIT and MITSIM both represent travel demand by OD and departure time interval, an important distinction is that MITSIM travel demand represents actual vehicles that will be released into the network, while DynaMIT travel demand represents habitual demand based on prior off-line estimates.) DynaMIT computes deviations from the habitual travel demand based on information gathered through surveillance during simulation (Ben-Akiva et al., 2000).

DynaMIT also requires the description of socioeconomic characteristics for vehicles in the habitual demand representation. These socioeconomic characteristics determine information availability and response characteristics that are used to model route choice decisions. DynaMIT modifies habitual demand according to surveillance information that becomes available during simulation.

3.2.3 DynaMIT State Estimation

As shown in Figure 3-4, state estimation in DynaMIT is an iterative process between the demand and supply simulation. The demand simulation computes estimated demand. This demand is then loaded into DynaMIT's mesoscopic supply simulator to compute a new OD assignment matrix. This process iterates until convergence; that is, until the demand estimates are consistent with assignment matrix generated by the supply simulator.

Information provision enters into the DynaMIT models in both the supply and demand simulators.

3.2.3.1 DynaMIT Demand Simulation

DynaMIT uses surveillance information (sensor counts) to estimate current demand since we cannot a priori know actual travel demand for a given day. This process is referred to as OD Estimation (Ben-Akiva et al. 2000). DynaMIT uses a Kalman Filtering framework formulated by Ashok and Ben-Akiva (1993), which uses the information contained in historical OD data as well as surveillance traffic count data to generate OD estimates in real-time. Instead of conventional time-series approaches to estimation, this approach is based on demand *deviations* from historical values; the differences in estimated current demand vs. historical demand over a time period is richer in information than the absolute values because the deviations capture information about latent factors that affect travel demand over the course of time.

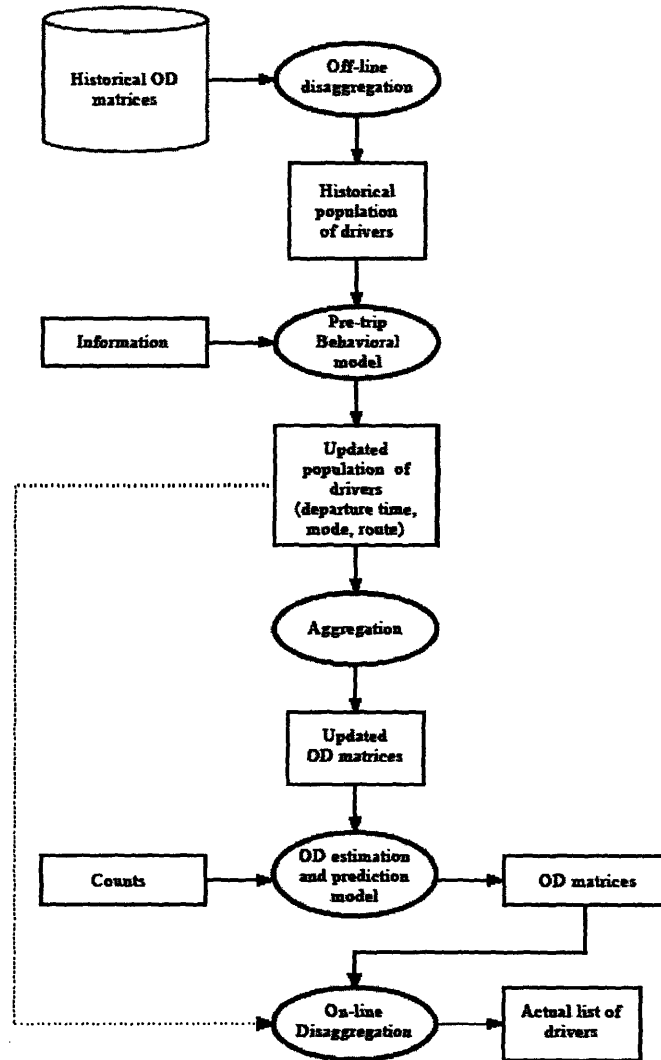

Figure 3-5 DynaMIT Demand Simulation

Source: Antoniou (1997)

An expanded view of the DynaMIT processing flow, including the demand simulation steps (ie. Pre-trip Behavioral Model) is shown in Figure 3-5, from Antoniou (1997). In order to account for the effect of pre-trip information, DynaMIT uses behavioral models to perform a pre-trip update of historical demand *before* computing the deviations between (estimated) current and (actual) historical demand. This model allows for drivers to change:

1. previously assigned paths,
2. departure time, or

3. transportation mode (ie. driving trip cancelled).

The pre-trip behavioral update model is formulated as a nested logit model (Antoniou 1997) and can have a choice set as illustrated in the following diagram.⁴ This particular pre-trip behavioral model is presented as an example only to illustrate exactly how the provision of ATIS will affect the DynaMIT demand simulation. Please refer to Antoniou (1997) for a detailed discussion of the model specification.

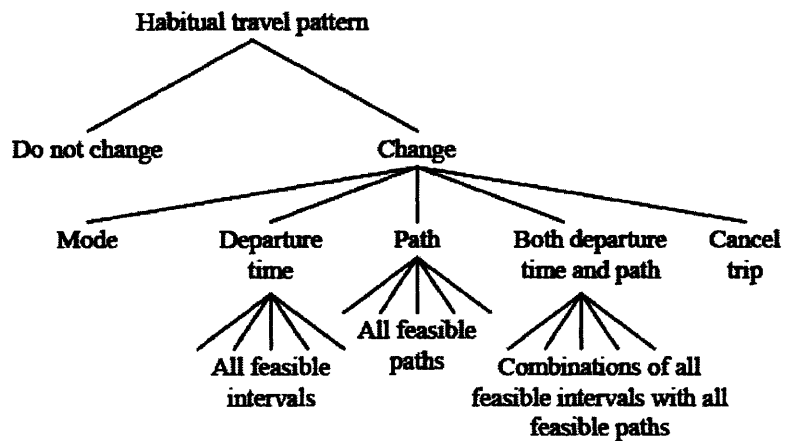

Figure 3-6 DynaMIT Pre-trip Choice Tree

To understand the effect of information in this nested logit model we need to consider the specification of systematic utility of the alternatives in the choice set. The systematic utility of the alternatives in the above nested logit model depends on the following set of variables: (Note: In practice, the full model specification presented in Antoniou (1997) can be simplified if data does not exist for a subset of these variables).

⁴ This choice tree assumes prescriptive information, not descriptive information. DynaMIT also has capabilities to model descriptive ATIS, but, as previously discussed, this thesis is primarily concerned with descriptive information. (See xxx)

tt_{hp}^H	historical travel time for departure time interval h and path p
tt_m^H	historical travel time for <i>other</i> (than car) mode
tt_{hp}^I	travel time provided by the information system for departure time h and path p
$tt_{hp'}^I$	travel time provided by the information system for departure time h and habitual path p'
$tt_{h'p}^I$	travel time provided by the information system for habitual departure time h' and path p
$tt_{h'p'}^I$	travel time provided by the information system for habitual departure time h' and habitual path p'
dt_h	departure time of traveler departing in interval h
at_{hp}^I	arrival time of traveler departing in interval h on path p
$at_{h'p}^I$	arrival time of traveler departing in habitual interval h' on path p
$at_{hp'}^I$	arrival time of traveler departing in interval h on habitual path p'
$at_{h'p'}^I$	arrival time of traveler departing in habitual interval h' on habitual path p'
$at_{h'p'}^H$	habitual arrival time for traveler with habitual interval h' and path p'
T	time that the information is sent to the traveler
VOT_{lo}	low value of time indicator
VOT_{med}	medium value of time indicator
VOT_{hi}	high value of time indicator
P_w	work as trip purpose (0-1 dummy variable)
P_l	leisure as trip purpose (0-1 dummy variable)
CF_p	commonality factor for path p
l_p	length of path p
w_p	length of path p in highway
c_p	out-of-pocket monetary cost for path p
s_p	number of signalized intersections in path p
f_p	number of left turns on current path p

Figure 3-7 Variables in DynaMIT Pre-Trip Behavioral Model

ATIS enters into the pre-trip behavioral model through the tt^I travel times provided by the information system. Note that these ATIS travel times are distinct from the tt^H habitual travel times which represent ‘conventional wisdom’ about travel times,

and are not estimated from current situations. To illustrate the effect of ATIS travel times on the systematic utilities in the nested logit pre-trip behavioral model, consider the model specification for the *do not change (DNC)* alternative:

$$\begin{aligned}
 V(DNC) = & \beta_1^d VOT_{lo} tt_{h,p}^I + \beta_2^d VOT_{mod} tt_{h,p}^I + \beta_3^d VOT_{hi} tt_{h,p}^I + \\
 & \beta_4^d CF_{p'} + \beta_5^d l_{p'} + \beta_6^d \omega_{p'} + \beta_7^d c_{p'} + \beta_8^d s_{p'} + \beta_9^d f_{p'} + \\
 & \beta_{10}^d \max(dt_{h'} - T, 0)
 \end{aligned}$$

Equation 3-3 DynaMIT Pre-Trip Behavioral Model

where the variable names are as in Figure 3-7. This example clearly shows how ATIS affects the systematic utility of driver alternatives, and, hence, how ATIS modifies the probabilities that drivers will maintain their habitual path choice, mode choice or departure time choices. Specifically, this probability is:

$$P(DNC) = \frac{e^{V(DNC)}}{e^{V(DNC)} + e^{V(C)}}$$

Equation 3-4 DynaMIT Path Choice Logit Model

where $V(C)$, the utility for the *change* alternative, is the maximum expected utility of the set of lower level alternatives in Figure 3-6:

- Change Mode
- Change Departure Time
- Change Path
- Change Departure Time and Path
- Cancel Trip

The effects of ATIS are incorporated into these driver decisions in a similar manner - through the inclusion of tt^I informed travel times as distinct from habitual travel times.

3.2.4 DynaMIT Supply Simulation for Estimation

The DynaMIT supply simulator loads the simulated pre-trip demand (discussed above) into the supply network. DynaMIT uses en-route behavioral models for route choice during the supply simulation to capture the effects of en-route information on drivers already on the network. The impact of information enters the en-route models in the same way as discussed in the path choice component of the pre-trip model summarized above.

The result of the DynaMIT supply simulation results in a network state that is compared against the observed surveillance data. DynaMIT performs multiple iterations of pre-trip demand *and* supply simulation until the pre-trip demand is congruent with the supply simulation results.

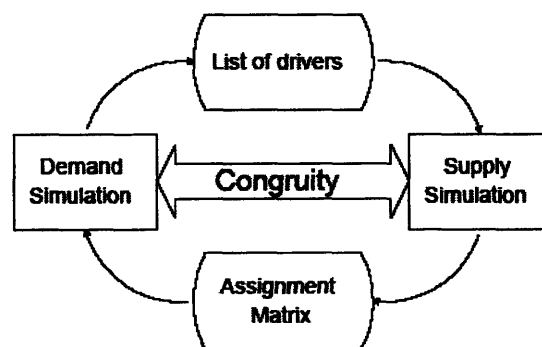

Figure 3-8 A DynaMIT Estimation Iteration

3.2.5 DynaMIT Prediction

In order to generate predictive guidance, DynaMIT must also forecast OD estimates in real-time. DynaMIT uses an autoregressive process in a Kalman Filtering approach to do this. The autoregressive process models the temporal relationship among deviations in estimated OD flows, and thus implicitly accounts for unobserved factors that are correlated over time (Ashok, 1996). The OD prediction computes estimates of future OD flows from the OD estimates computed in state estimation (discussed above).

3.2.5.1 DynaMIT Supply Simulation for Prediction

The DynaMIT supply simulator then loads the forecasted demand into the supply network. DynaMIT uses en-route behavioral models for route choice during the supply simulation to capture the effects of en-route information on drivers already on the network, in exactly the same way as in the supply simulation step for estimation. The impact of information enters the en-route models in the same manner as previously discussed. (See section 3.2.3.1)

The result of the DynaMIT supply simulation results in a network state that is compared not against the observed surveillance data, (observed surveillance does not exist in the prediction step) but rather to ensure that the driver behavior in response to ATIS is consistent with the guidance.

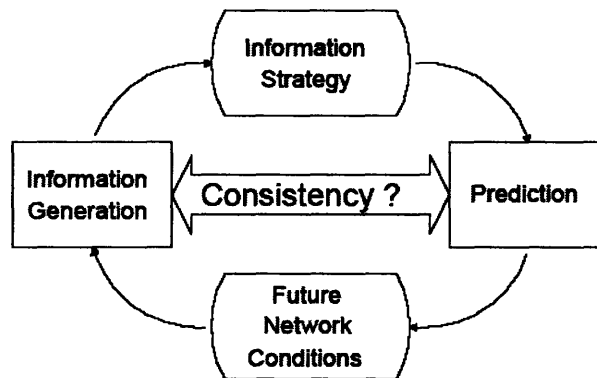

Figure 3-9 A DynaMIT Prediction Iteration

3.3 ATIS Evaluation Framework

The previous two sections have provided an overview of the processing steps in both the MITSIM and DynaMIT traffic simulators, and have also highlighted the steps where ATIS affects simulation behavior. This section discusses the software system that integrates these two software components into an ATIS evaluation framework, as illustrated in Figure 3-1.

The ATIS Evaluation Framework consists of C++ objects that have been compiled into both the MITSIM and DynaMIT code bases. The functionality to synchronize and interoperate DynaMIT and MITSIM is controlled through the MITSIM and DynaMIT start-up configuration files, as detailed in Appendix A.

The following diagram represents the processing timeline of the integrated ATIS evaluation framework.

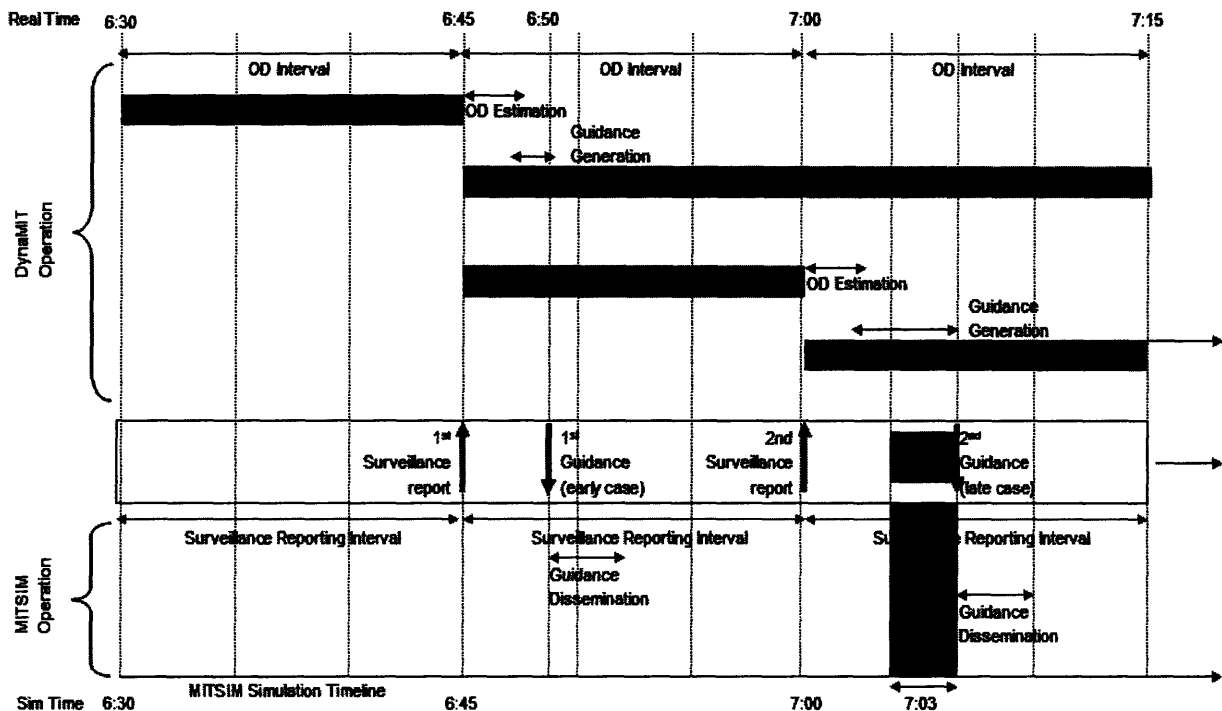

Figure 3-10 ATIS Evaluation with MITSIM and DynaMIT

In this scenario, MITSIM and DynaMIT are started at the same ‘simulation time’ of 6:30am. Until 6:45am, the end of the first ‘OD Interval’⁵, both MITSIM and DynaMIT are operating concurrently; MITSIM is performing micro simulation while DynaMIT is running through initialization procedures. MITSIM must be configured to report surveillance to MITSIM at the end of each DynaMIT OD Interval. In this example, DynaMIT’s OD Interval is configured to be 15 minutes, so MITSIM’s first surveillance report occurs at 6:45am. DynaMIT receives the surveillance information (designated by the ‘up arrow’ in the diagram) and begins a period of OD Estimation, as discussed in section 3.2. Following the computational time required for OD Estimation, DynaMIT performs prediction and guidance generation. (The small horizontal arrows in the diagram illustrate the computational time required for the processing steps, while the thicker, shaded bars illustrate the data over which the computation is being performed. For instance, the first DynaMIT guidance generation in this example finishes at 6:50am, although the guidance contains predicted travel times through 7:15am.) At simulation time of 6:50am, DynaMIT transmits this information back to MITSIM, and the guidance is made available to the guided driver population in the micro simulation.

Note that in practice, the computational requirements imposed in the DynaMIT state estimation and guidance generation processes may take much longer. But the benefits of predictive guidance are diminished if they are not broadcast in a timely manner (Balakrishna, 2004). In order to decouple the computational requirements and available processing power from the evaluation of ATIS, the simulation framework development includes a ‘computational delay’ mechanism that is capable of temporarily halting the MITSIM micro simulation if guidance is still outstanding at some pre-specified interval. Figure 3-10 illustrates this special case of ‘computational delay’ in the second period of state estimation and guidance generation; note the shaded box representing the temporary halt of MITSIM operation until the guidance generation process from DynaMIT is completed in ‘simulation’ time.

⁵ An Origin-Destination Interval (OD Interval) is a computational artifact in DynaMIT – it represents the time slice over which to perform OD Estimation and Prediction

The following diagram offers an alternate flow-chart description of the ATIS evaluation framework without timing details.

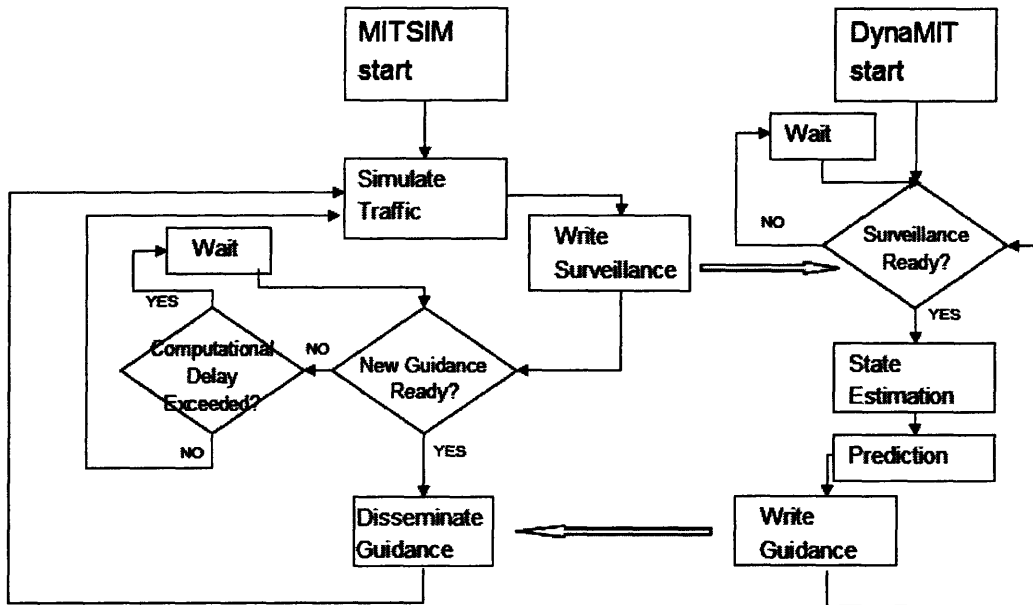

Figure 3-11 ATIS Evaluation Flowchart

MITSIM and DynaMIT must be specially configured in order to operate together in the ATIS evaluation framework. Sample configurations and operating instructions are detailed in Appendix A.

3.3.1 ATIS Evaluation Methodology

The ATIS evaluation framework is intended to be used according to the following methodology. See Figure 3-12, below.

This evaluation methodology assumes that a calibrated MITSIM model exists for a given network, including all demand and supply characteristics. The first step in the evaluation methodology is to calibrate DynaMIT against the MITSIM model. This includes calibration of the DynaMIT network supply characteristics, route choice parameters and historical OD representations. The quality of this calibration can be checked by comparing reported simulated flows from DynaMIT against reported surveillance over the same time period from MITSIM.

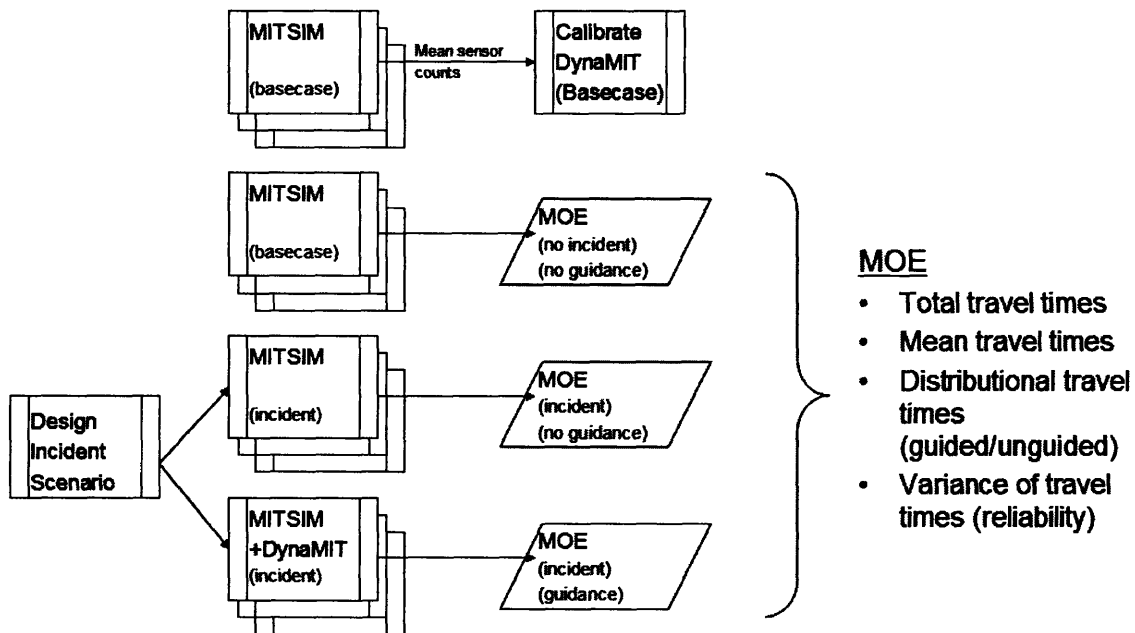

Figure 3-12 ATIS Evaluation Methodology

The next step is to ascertain a baseline performance from MITSIM before considering the impact of ATIS. Relevant MITSIM ‘measures of effectiveness’ (MOE) typically include total and mean travel times and distributional travel times across guided and unguided driver populations. It is also possible to examine these metrics according to driver departure and arrival time and route-choice decisions.

Since ATIS is most promising under conditions of non-recurrent congestion, we are typically interested in some perturbation of the baseline network conditions that modifies network supply or demand in some systematic way. Of course, ATIS will impact network performance even without such a change to network conditions, but if the MITSIM historical travel time database (conventional driver wisdom) is already a very good representation of what drivers will experience, we won't expect significant benefits from ATIS - users are already making the best decisions they can.

As illustrated in Figure 3-12, an incident is a good example of such an unforeseen impact to network supply. Of course, the methodology can still be used even if the network demand or supply modification is some other change (ie. spike/decline in specific demand, road closure, new alternate route, etc...). The next step in the methodology, then, is to capture the effects of the incident (or other change) in MITSIM without the presence of ATIS.

Finally, DynaMIT predictive guidance is used to deliver ATIS to MITSIM, and the resulting benefits can be compared against the baseline results.

Chapter 4

4 ATIS Case Study: A Simple Network

The objective of this chapter is to demonstrate the ATIS Evaluation framework and methodology described in chapter 3 for incident scenarios and diversion strategies on a simple network. Results from this experiment are drawn from a hypothetical network that illustrates the basic impact of ATIS under incident conditions (non-recurrent congestion). The ATIS evaluation results from this simple network offer important insights for the ensuing policy discussion (Chapter 6).

The hypothetical network being considered is:

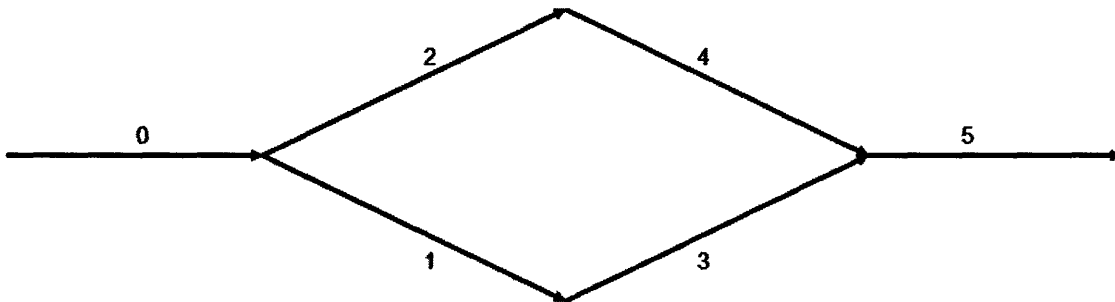

Figure 4-1 Simple Network for ATIS Evaluation

This network design is considered for two reasons. First, the simple network topology offers the possibility for an intuitive understanding of the impact of ATIS, so that lessons from this network can influence the planning and policy discussions in a later chapter. Next, because we have strong a priori hypotheses on the impacts of ATIS on this simple network, we can validate the proper functioning of the ATIS evaluation framework that has been developed.

Travel demand in this network originates at the start of link 0 and ends at the end of link 5. There are basically two paths in the route choice set; the path defined by links {0,2,4,5} and the path defined by link {0,1,3,5}. The impact of ATIS is clearly localized to the first (and only) route-choice decision at the end of link 0. Note that the network is not symmetric: capacities on links 1 and 3 are smaller than on links 2 and 4. Network performance was evaluated over a three-hour period. (We arbitrarily call this the period from 6:50 AM to 9:50AM).

The evaluation of ATIS impact on this network focuses on varying levels of guidance market penetration under two different demand scenarios. This experimental design was chosen judiciously to illustrate the effect of ATIS on network performance at different market penetrations, and under different demand scenarios. We hypothesize that the impact of ATIS will be significantly different depending on whether diverted traffic results in congestion on the alternate route. More specifically, we expect that ATIS benefits will be maximized when demand is low enough so that diverted traffic results in free-flow conditions on the alternate route. Similarly, we expect that ATIS benefits to guided drivers will be less significant when the alternate route becomes congested. Finally, we expect that unguided drivers will benefit moderately from ATIS in both demand scenarios.

The results in this section confirm each of the above hypotheses, and demonstrate that, in this simple network, the provision of ATIS benefits both guided and unguided drivers. We also confirm that ATIS benefits are sensitive to market penetration.

4.1 Calibration Results

The first step of the ATIS evaluation methodology presented in section 3.4.1 is to calibrate DynaMIT to the MITSIM traffic simulation software. In this hypothetical network calibration of the supply and route-choice parameters representation in DynaMIT is relatively straightforward and can be performed manually. Additionally, an off-line DynaMIT demand calibration process was performed in order to develop a new historical demand database for DynaMIT. To quantify the fit, we compute various simulation error statistics, as follows:

$$RMSError = \sqrt{\frac{1}{N} \sum_n (y_n^s - y_n^a)^2}$$

Equation 4-1 Root Mean Square Error

$$RMS\%Error = \sqrt{\frac{\frac{1}{N} \sum_n (y_n^s - y_n^a)^2}{\sum_n (y_n^a)^2}}$$

Equation 4-2 Root Mean Square Percent Error

$$MSError = \frac{1}{N} \sum_n (y_n^s - y_n^a)$$

Equation 4-3 Mean Simulation Error

$$Mean\%Error = \frac{\frac{1}{N} \sum_n (y_n^s - y_n^a)}{\sum_n y_n^a}$$

Equation 4-4 Mean Percent Error

where:

- N is number of sensors over which the calibration is being performed
- y_n^s is the simulated (DynaMIT) value of the sensor count at sensor n
- y_n^a is the ‘actual’ (MITSIM) value of the sensor count at sensor n

These four statistics are quantitative measures often used to evaluate a simulation model.

The results are shown in the following table:

Root Mean Square Error	Root Mean Square % Error	Mean Simulation Error	Mean % Error
111.04 veh/hr	8.5 %	-48.833 veh/hr	-1.7%

Table 4-1 Simple Network Calibration Results

The root mean square error (and root mean square % error) is a measure of the deviation of DynaMIT sensor counts from the MITSIM reported surveillance. The magnitude of the root mean square error (RMSE) can be evaluated only against the mean value of the sensor count, which is best seen by the root mean square percent error (RMSPE). Here, RMSPE is 8.5%. The mean simulation error (MSE) and mean percent error (MPE) are useful in examining a systematic bias in the simulation. Here, MPE is 1.7%. These results are consistent with previous calibrations (Chauhan, 2003).

4.2 Low Demand Scenario

The first scenario investigates the effects of ATIS on an incident on link 2 of the simple network. (See Figure 4-1, above). The incident lasts for 1 hour, from 6:50 AM to 7:50 AM, and is designed to completely block all lanes. The demand in this scenario is 1000 vehicles/hour, well under the capacity required for congestion break-down conditions. We measure network performance characteristics only for those vehicles that departed while the incident was still active so as not to dilute the study with free-flow travel conditions.

4.2.1 Baseline Performance

The baseline performance of this network with no guidance under incident and non-incident conditions was established through simulation using the ATIS evaluation framework described earlier in this thesis.

Under recurrent congestion conditions (no incident), drivers make the route choice decision between paths $\{0,2,4,5\}$ and $\{0,1,3,5\}$ using representative mean habitual travel times. This results in conditions approximating a user-optimal traffic assignment, where any individual driver cannot significantly improve his/her travel time by changing paths. The impact of ATIS in this scenario was not evaluated; theoretically, it would have no impact since drivers are already making the best decision that they can.

However, under non-recurrent conditions (ie. incident on link 4), drivers make the route choice decision between paths $\{0,2,4,5\}$ and $\{0,1,3,5\}$ using incorrect mean

habitual travel times. As a result, we know that *user*⁶ performance will be degraded. This is evident when we consider the mean travel times for drivers under the incident and non-incident case; in the incident scenario, drivers suffer a 47.8% increase in mean travel times from 25.8 minutes to 47.75 minutes.

Another aspect of user performance is the ‘predictability’ of travel times. If travel times of similar trips over periods of time are highly volatile then drivers will have a difficult time to effectively budget their time. Please see Wunderlich et al (2001) for a discussion of trip reliability under the impact of ATIS. In our simulation case study we can use the *a posteriori* measures of standard deviation of travel times as a measure of the *a priori* predictability of the trip. The incident greatly increases the standard deviation of the travel times from 1.65 minutes under recurrent traffic conditions to 16.5 minutes under the incident scenario.

	Total Travel Time	Mean Travel Time	Standard Deviation of Mean Travel Time
No Incident	430 veh-hrs	25.8 min	1.65 min
Incident	809 veh-hrs	48.7 min	16.5 min
% change	+88%		+900%

Table 4-2 Incident/Non-Incident Baseline Results

Note that *system* performance, measured as total travel time over all drivers, is also increased from 430 vehicle-hours to 809 vehicle-hours, an 88% increase. (Recall that this total travel time accrues only over the 1 hour period of that the incident is in place on link 2). Although this result shows that the *system* quality of service degrades along with *user* quality of service in this simple network, this only occurs because these baseline results consider only one type of user: unguided users. It is quite obvious that, on larger study areas of more complex traffic networks certain subsets of drivers (ie. guided and unguided) can experience longer travel times even though the system performance (total travel time) improves. The converse situation is also possible.

⁶ Note the distinction between *user* and *system* network quality of service measures: Mean travel times and standard deviations are used for *user* metrics while total travel time (veh-hrs) are used for *system* metrics. Benefits in *user* metrics from ATIS do not necessarily accompany *system* benefits and vice-versa.

4.2.2 Sample Size Determination

The ATIS evaluation results are stochastic (stochasticity is introduced in both MITSIM and DynaMIT), so the simulation results are random variables. We therefore require a number of simulation runs in order to arrive at reasonable confidence intervals for the results. We base the sample size determination on the baseline results of the incident case (0% guidance), since this is the worst-case scenario (travel time variances are higher in the non-recurrent congestion case); in this way we can guarantee that we meet the minimum confidence intervals at other levels of ATIS market penetration. Note that we could arrive at more precise estimates on the sampling error if we estimated standard deviations and computed new allowable errors using equation 4-5 at each level of market penetration.

The sample size determination is as follows:

$$z_{\alpha/2}(\sigma / \sqrt{N}) = d$$

Equation 4-5 Sample Size Determination

where:

- $z_{\alpha/2}$ is the critical value of the standard cumulative normal distribution for a given confidence level α .
- σ is the standard deviation of the population
- N is the sample size
- d is the maximum allowable units of error

Using the computed estimate for the standard deviation of the sample population mean of 260 seconds, selecting $\alpha = 10\%$, and using $N=5$ simulation runs, we achieve a maximum error of $d = 191.9$ seconds. Roughly speaking, for mean travel times, this allowable error is about 1.5 minutes on forty (a 3.75% error) which is more than appropriate for our evaluation. To summarize, we can be 90% sure that the results on mean travel times will fall within 191.9 seconds of the true mean.

Similarly, the estimated standard deviation for total travel time is 70.17 vehicle-hours, so our maximum error for total-travel time with N=5 simulation runs is approximately 51.8 vehicle-hours. Roughly speaking, the error in our total travel time statistics will be 50 vehicle-hours on approximately 700 total vehicle-hours (less than a 10% error).

These *maximum* possible error limits are illustrated using vertical error bars in the ensuing graphs. They are included to remind the reader of the worst-case 90% confidence interval on the simulation results.

4.2.3 ATIS: User Performance

When predictive guidance generated by DynaMIT is broadcast to a subset of drivers (in the incident scenario) we would expect that these drivers modify their route choice decisions to divert from the path with the incident. Recall that demand is well under network capacity (~1000 vehicles/hr) in this first simulation scenario, so that even under diversion conditions there is little or no resulting congestion along the alternate path. Therefore, we expect that network performance increases monotonically as market penetration of ATIS increases. Results are illustrated in Figure 4-2.

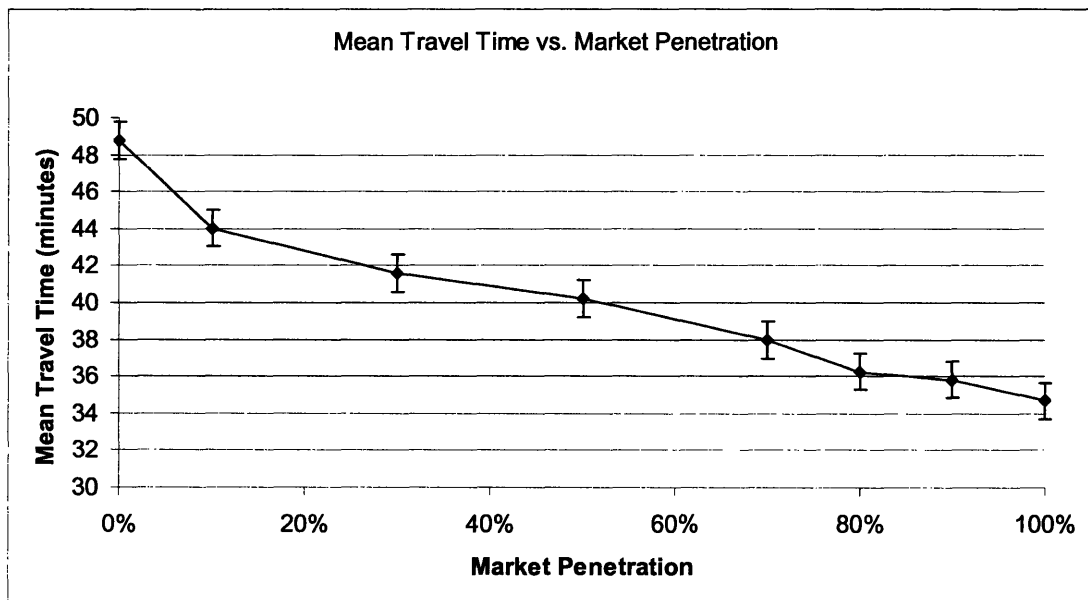

Figure 4-2 Mean Travel Time vs. Market Penetration (Low Demand)

The benefits of ATIS in this simple case are clear: the higher the market penetration, the more drivers are informed about the incident on the affected path. Again, since the diversion does not result in congestion on the alternate path, the marginal benefit of market penetration will remain approximately constant. The alternate route can accommodate all newly diverted traffic.

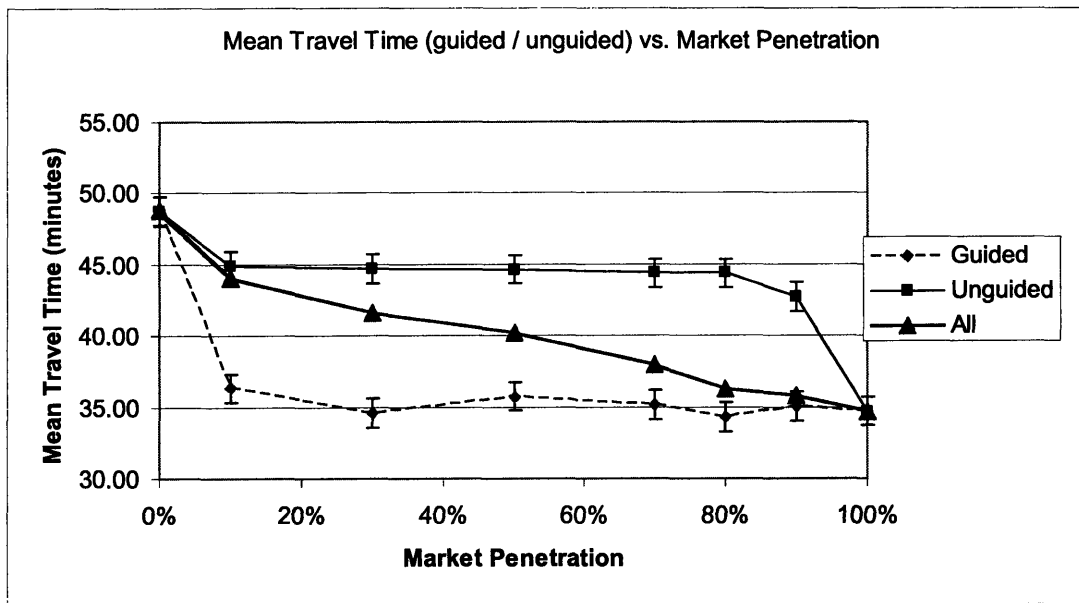

Figure 4-3 Distributional (guided/unguided) Mean Travel Time vs. Market Penetration

The effects of DynaMIT ATIS on average travel time are clearly beneficial for both guided and unguided drivers. The guided drivers are able to avoid the incident entirely, while the unguided drivers benefit from fewer cars in the queue behind the incident.

As ATIS market penetration increases under non-congested network conditions, the unguided drivers experience incremental benefit as fewer and fewer cars are involved in the incident queue. When the incident clears, the queue therefore takes less time to clear. In this network the benefit to unguided drivers is small, as evidenced by the low downward slope of the unguided driver line. Since the free-flow (ie. no incident) capacity is very large when compared to demand, the queue dissipates in just a few minutes after the incident clears. Other network topologies could be chosen to further emphasize the benefits of ATIS to unguided drivers. For instance, if the capacity of link

2 was small even after the incident was cleared, the additional congestion avoided by diversion of guided drivers would be more significant. Nevertheless, we expect that the marginal benefit to unguided drivers be constant and positive, even if it is small in this scenario. The data is consistent within the allowed error range.

Of course, the guided drivers benefit much more than the unguided drivers since the informed drivers can avoid the incident entirely. Because the diverted traffic is easily accommodated by the capacity on links 1 and 3 in this low-demand scenario, we expect that the marginal benefit of additional market penetration to guided drivers is constant (and positive). The data confirms this hypothesis within the allowed error range.

The mean travel time line for all drivers, both guided and unguided, is included for perspective. Clearly, the mean travel time is constrained to be within the mean unguided travel time (at 0% ATIS market penetration) and the mean guided travel time (at 100% ATIS market penetration).

When considering user performance under ATIS we should consider not only absolute travel time to drivers but also the reliability of those travel times. As described in Wunderlich et al., (2001) drivers incur costs above and beyond their actual travel time when they cannot accurately predict travel times. Figure 4-4, below, illustrates the reliability benefits conferred by ATIS under the 50% guidance scenario.

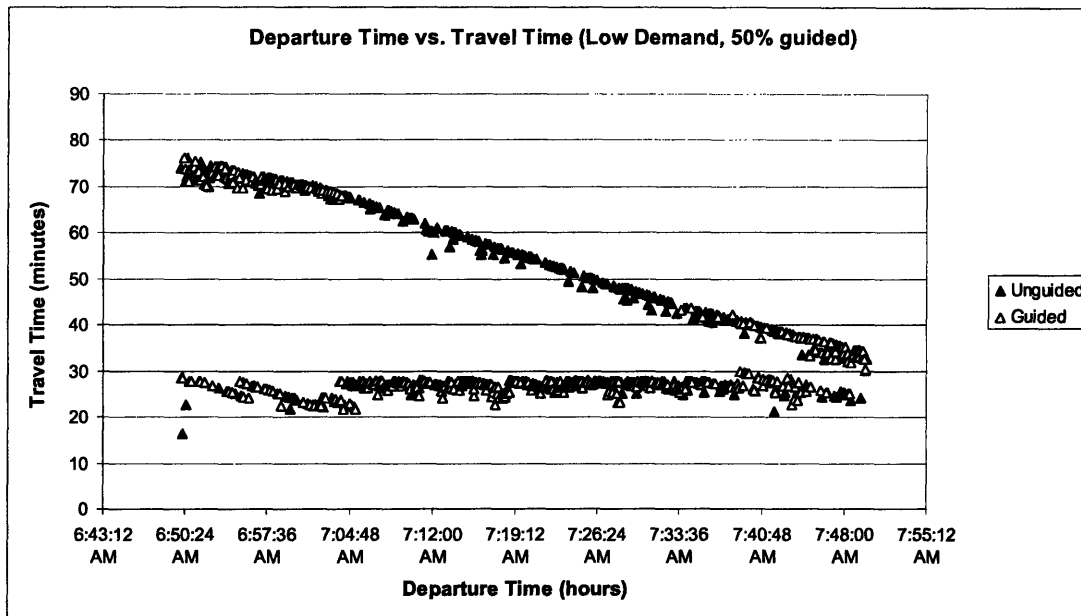

Figure 4-4 Departure Time vs. Travel Time (Low Demand, 50% guided)

The two lines in Figure 4-4 represent travel times along alternate paths to the destination. The downward-sloping line represents travel times along the path with the incident. Note that guided drivers almost exclusively take the unaffected route. (Note that since information is provided to guided drivers only once every 15 minutes, there are some guided drivers that take the blocked path before their first information update.) If we exclude the first 15 minutes where guided drivers had no information (they were, in essence, unguided), the standard deviation of travel times for guided drivers was 9.7 minutes, while the standard deviation for travel times of unguided drivers was 24.7 minutes. In other words, the guided drivers experience less differences in their travel times than do the unguided drivers.

4.2.4 ATIS: System Performance

The system performance, as measured by total travel time, also improves with market penetration of DynaMIT ATIS. As market penetration increases, an increasing share of the total travel time is borne by guided drivers who have a lower mean travel time. As a result, total travel time drops.

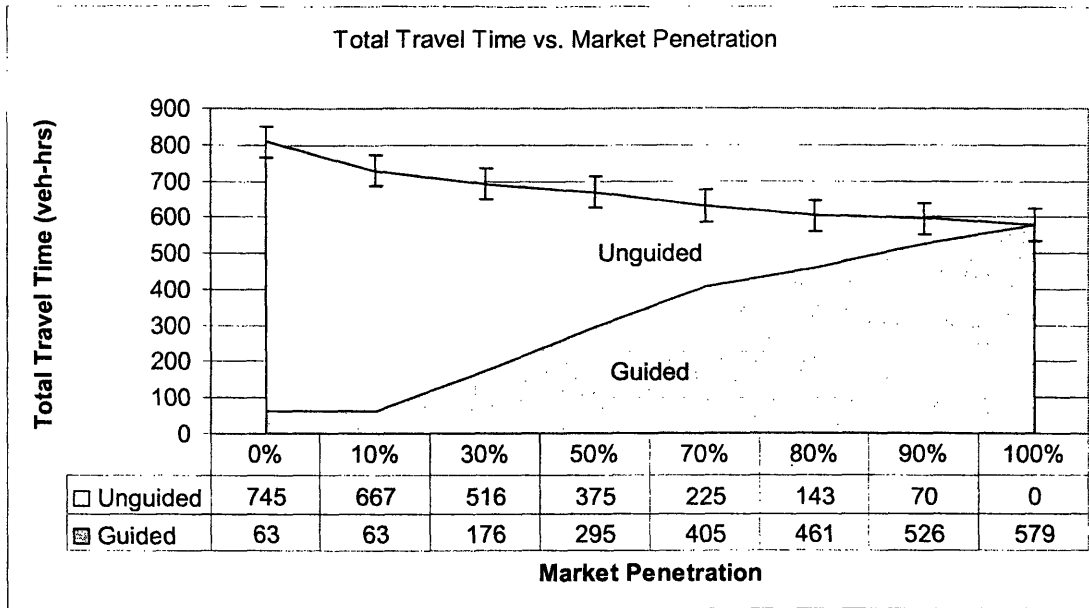

Figure 4-5 Total Travel Time vs. Market Penetration

The total travel time benefits are as follows:

Market Penetration	Total Travel Time (veh-hrs)	Total Travel Time Savings
0%	806	N/A
10%	730	9.4 %
30%	692	14.1 %
50%	670	16.8 %
70%	631	21.7 %
80%	604	25.1 %
90%	596	26.0 %
100%	579	28.2 %

Table 4-3 Total Travel Time Benefits under ATIS

Again, the total travel time savings in an absolute sense increase monotonically with the level of DynaMIT ATIS market penetration. Empirically, we can see that the marginal benefit of increased market penetration is roughly constant over the entire range.

4.3 High Demand Scenario

This next scenario again investigates the effects of ATIS on an incident on link 2 of the simple network (see Figure 4-1, above). Again, the incident lasts for 1 hour, from 6:50 AM to 7:50 AM, and is designed to completely block all lanes. However, the demand in this scenario is 4000 vehicles/hour, and easily drives the available capacity into congestion. Like before, we measure network performance characteristics only for those vehicles that departed while the incident was still active so as not to dilute the study with free-flow travel conditions.

4.3.1 Baseline Performance

The baseline performance of this network with no guidance under incident and non-incident conditions was established through simulation using the ATIS evaluation framework described earlier in this thesis.

In this scenario, drivers suffer an 87% increase in mean travel times from 29.1 minutes to 54.4 minutes.

The incident also greatly increases the standard deviation of the travel times from 1.52 minutes under recurrent traffic conditions to 19.3 minutes under the incident scenario.

	Total Travel Time	Mean Travel Time	Standard Deviation of Mean Travel Time
No Incident	1940 veh-hrs	29.1 min	1.52 min
Incident	3628 veh-hrs	54.4 min	19.3 min
% change		+87%	+1170%

Table 4-4 Incident/Non-Incident Baseline Results (High Demand)

Note that *system* performance, measured as total travel time over all drivers, is also increased from 1940 vehicle-hours to 3628 vehicle-hours, an 87% increase. (Recall that this total travel time accrues only over the 1 hour period of that the incident is in

place on link 2). The network performance degradation due to the incident is much more severe than the low-demand scenario, given that demand is now four times as high.

4.3.2 Sample Size Determination

Again, we use Equation 4-1 to compute maximum realized error based on our sample size determination. Using the computed estimate for the standard deviation of the sample population mean of 56.7 seconds, selecting $\alpha = 10\%$, and using $N=5$ simulation runs, we achieve a maximum error of $d = 49.8$ seconds. Roughly speaking, for mean travel times, this allowable error is less than one minute on forty (less than a 2.5% error) which is more than appropriate for our evaluation. To summarize, we can be 90% sure that the results on mean travel times will fall within 49.8 seconds of the true mean.

Similarly, the estimated standard deviation for total travel time is 63.3 vehicle-hours, so our maximum error for total-travel time with $N=5$ simulation runs is approximately 49.7 vehicle-hours. Roughly speaking, the error in our total travel time statistics will be less than 50 vehicle-hours on 500 total vehicle-hours (less than a 10% error).

Please see section 4.1.2 for a full discussion of sample size determination.

4.3.3 ATIS: User Performance

When predictive guidance generated by DynaMIT is broadcast to a subset of drivers (in the incident scenario) we would expect that these drivers modify their route choice decisions to divert from the path with the incident. But in this case, the demand (~4000 vehicles/hr) easily drives the network into congestion. As a result, there is not enough capacity to entirely accommodate the diverted traffic under free-flow travel conditions. This scenario is extremely sensitive to the phenomena of *overreaction*: if DynaMIT underestimates the number of vehicles that will actually switch paths based on the guidance that they will receive, excess congestion on the alternate path will move performance away from the user optimal ideal (Kaysi, 1992). However, DynaMIT is designed to generate *consistent* guidance to avoid this situation. Nevertheless, we may see some evidence of overreaction in the results. Therefore, we expect that user

performance increases monotonically as market penetration of ATIS increases, but only up to the point where overreaction sets in. In this high demand scenario, overreaction may be evident after 50% market penetration. (Note that overreaction did not occur in the low demand scenario.) Results are summarized in Figure 4-6.

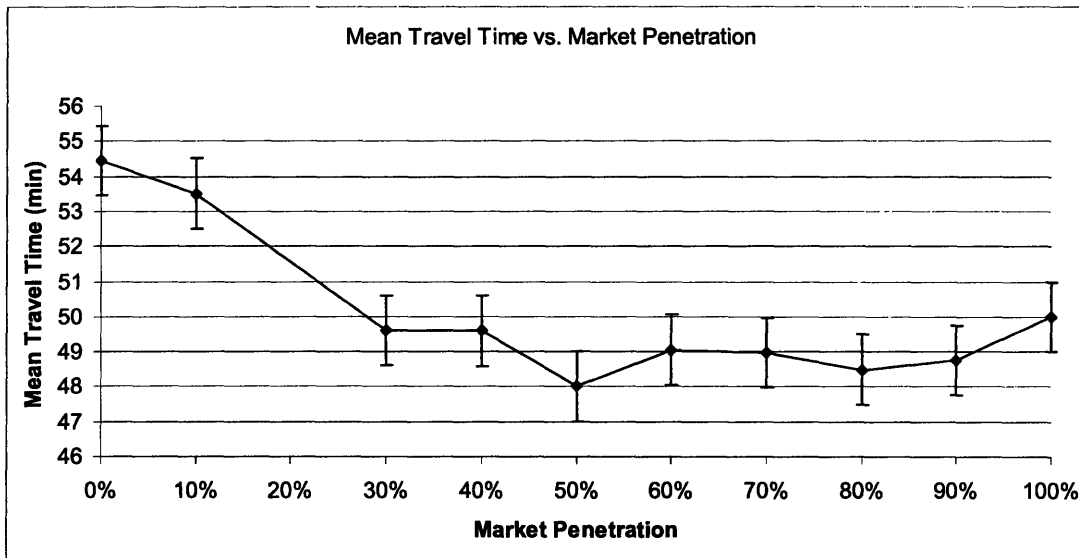

Figure 4-6 Mean Travel Time vs. Market Penetration (High Demand)

The benefits of ATIS in the high demand scenario are notably different from the low demand scenario: Market penetration improves mean travel time only until ~50% of the driver population is guided. Beyond this point mean travel times remain mostly flat, and there is only slight degradation of mean travel time performance between 50% and 60% market penetration.

Note that there are two points of interest on the curve in Figure 4-6. First, the relatively flat tail of the curve (marginal travel time change is small for market penetration above 60%) is likely due to the fact that the network capacity becomes exhausted under the high demand. We can confirm this result by examining the distributional behavior of guided and unguided travel times in Figure 4-7. Note that the mean travel time for guided drivers increases and converges to the unguided mean travel time at market penetration of ~90%. The network simply does not have the capacity to handle the diverted traffic as in the low demand case.

The second point of interest is the inflection point in mean travel time at the 50% market penetration level. (Note the dip in mean travel time at 50% market penetration in Figure 4-6.) While lack of sufficient capacity on the alternate route can explain the diminishing marginal benefit of guidance, it cannot explain the dip in user performance at an intermediate point. There are two possible explanations here. Likely, there is slight overreaction past the 50% point due to the guidance generated by DynaMIT. This may be an artifact of the practical configuration of DynaMIT including, but not limited to, the long information update interval (in this case 15 minutes), the maximum number of prediction iterations, or slight differences between the network supply representations and/or route choice parameters in MITSIM and DynaMIT. Alternately, note that the dip at 50% market penetration does appear within the bounds of our 90% confidence interval – we should also note that this point may not actually be significantly off the trend.

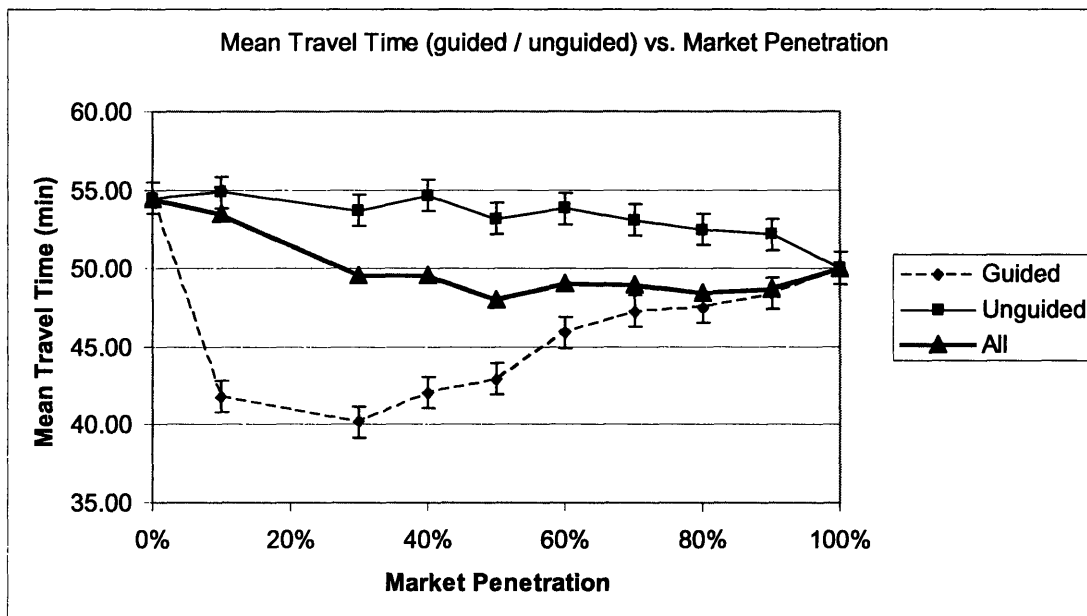

Figure 4-7 Distributional (guided/unguided) Mean Travel Time vs. Market Penetration (High Demand)

As in the low demand scenario, the distributional effects of DynaMIT ATIS on average travel time are clearly beneficial for both guided and unguided drivers. The guided drivers are able to avoid the incident entirely, while the unguided drivers benefit

from fewer cars in the queue behind the incident. However, note the marginal decrease in benefit to mean travel time of guided drivers in Figure 4-7. As more and more guided drivers are diverted to the alternate route they impose increasing congestion costs on each other, and must share the benefits. As before, we note the slight improvement to unguided drivers with increasing ATIS.

As in the low demand scenario, we should also consider reliability of travel times to drivers. Figure 4-8, below, illustrates the reliability benefits conferred by ATIS under the 50% guidance scenario.

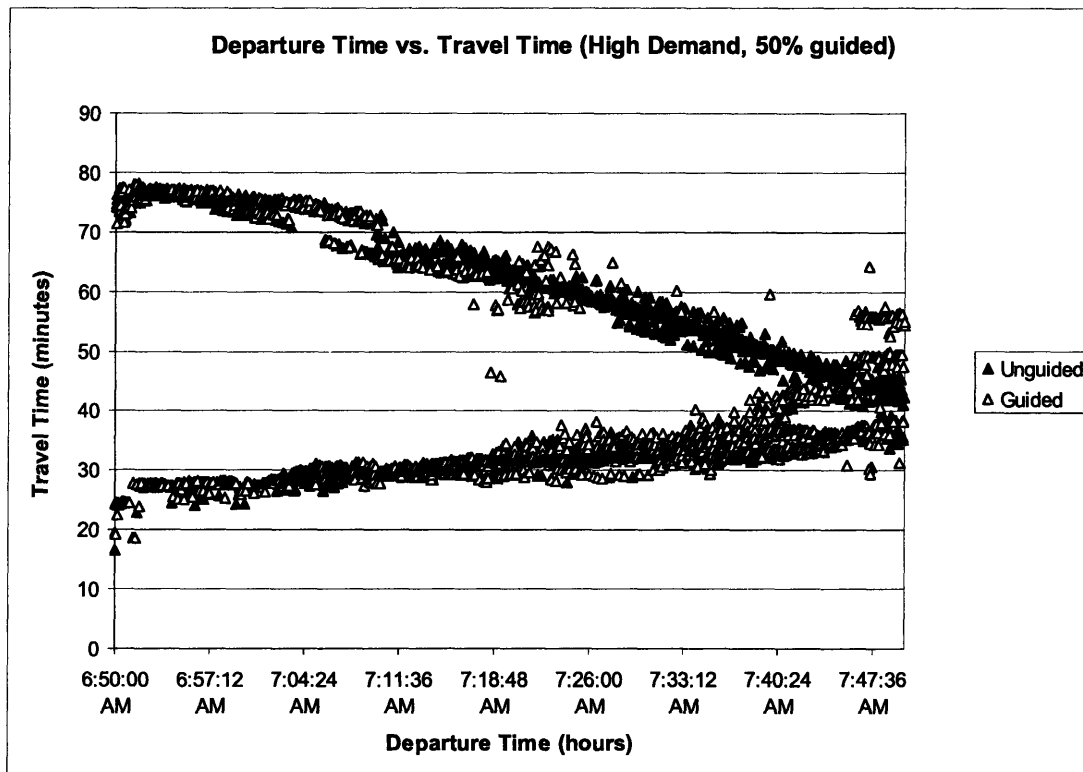

Figure 4-8 Departure Time vs. Travel Time (High Demand, 50% guided)

The two lines in Figure 4-8 represent travel times along alternate paths to the destination. The downward-sloping line represents travel times along the path with the incident. Note that most guided drivers take the unaffected route, although the ensuing congestion on the alternate route does increase travel times along this path. Also note that some guided drivers still decide to take the path with the incident even after

receiving predictive guidance about traffic conditions. There are two possible explanations for this phenomena: First, DynaMIT predicts that travel times on the alternate route will rise with congestion from diverted traffic, and the difference in travel times between the two paths is therefore not as severe as in the low demand scenario. Second, it is possible that some of the guided drivers were already in the wrong lane when they received the first guidance from DynaMIT, and were not able to successfully cross successive lanes on link 0 of the network to change their route. Again, if we exclude the first 15 minutes where guided drivers had no information (they were, in essence, unguided), the standard deviation of travel times for guided drivers was 12.7 minutes, while the standard deviation for travel times of unguided drivers was 15.0 minutes. Although not as pronounced as in the low demand scenario, the guided drivers do experience less spread in their travel times than do the unguided drivers.

4.3.4 ATIS: System Performance

In the high demand scenario, the system performance, as measured by total travel time, improves only until the 50% market penetration level (see table 4-3). At low ATIS market penetration levels, an increasing share of the total travel time is borne by guided drivers who have a lower mean travel time. As a result, total travel time drops. However, at the 50% market penetration level and higher, the average benefit to guided drivers drops due to congestion on the alternate route, and there are few (if any) additional benefits from more pervasive ATIS. See Figure 4-9 and Table 4-5, below.

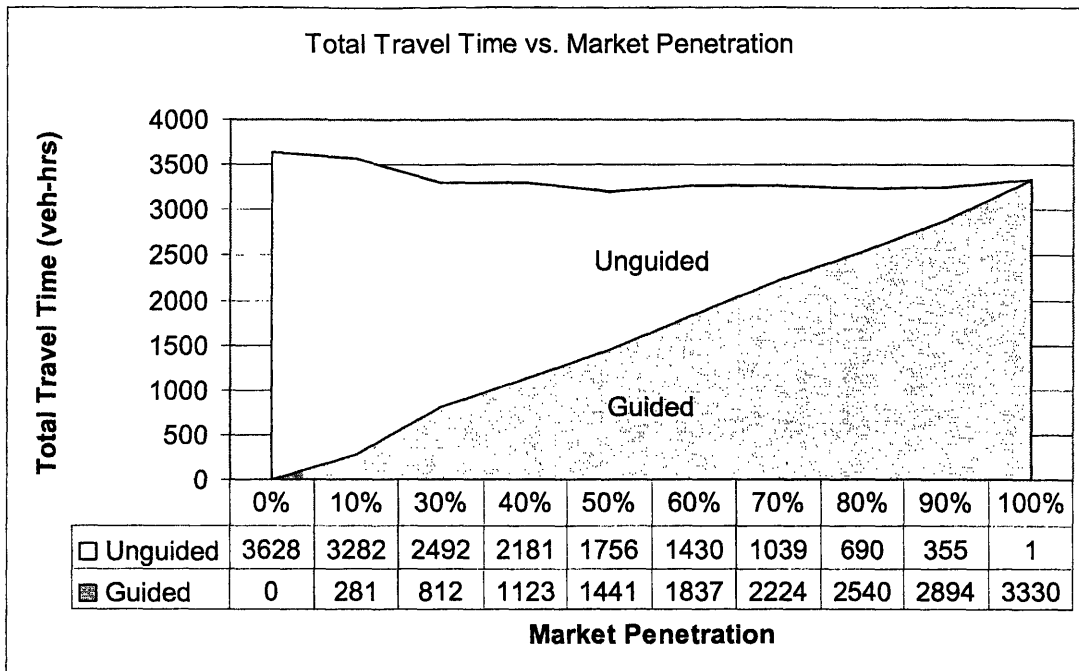

Figure 4-9 Total Travel Time vs. Market Penetration (High Demand)

The total travel time benefits for the high demand scenario are as follows:

Market Penetration	Total Travel Time (veh-hrs)	Total Travel Time Savings
0%	3628	N/A
10%	3564	1.8 %
30%	3305	8.9 %
50%	3197	11.9 %
70%	3267	10.1 %
80%	3230	10.98 %
90%	3250	10.44 %
100%	3331	8.9 %

Table 4-5 Total Travel Time Benefits under ATIS

Chapter 5

5 ATIS Case Study: Lower Westchester County

The objective of this chapter is to demonstrate the ATIS Evaluation framework and methodology described in chapter 3 for an incident scenario on a network of Lower Westchester County (LWC), NY. Results from this proof-of-concept experiment validate the proper functioning of the ATIS Evaluation Framework presented earlier in this thesis, but also give some evidence that the DynaMIT model is not yet well-calibrated against the MITSIM ground-truth model.

A brief description of the study network is given first. Sample results from preliminary simulation runs are presented, along with a discussion of results and directions for future work on this network.

5.1 Network Description

The LWC network is just north of Manhattan, New York. The network is extremely congested, and has heavy traffic on both freeways and parkways, resulting from a varied mix of commuters and travelers. Freeways and Parkways in the focus network include I-87 (the New York State Thruway), I-95 (the New England Thruway), I-287 (the Cross Westchester Expressway), I-684, the Cross County Parkway, the Hutchinson River Parkway, the Sprain Brook Parkway, the Saw Mill River Parkway, the Bronx River Parkway and the Taconic State Parkway. Most of the freeways and parkways, except Cross County Parkway and I-287, run north/south. The general extent of the project network is shown in Figure 5-1.

The network is represented as a set of 579 O-D pairs connected by 1659 directed links. These links represent the physical links on the network, and are further subdivided into 2421 segments to model changing link characteristics.

The study interval considers vehicles that depart from 7:00AM until 9:00AM, with DynaMIT ATIS being provided over the interval of the incident from 7:00AM to 8:00AM. We run the simulation from 6:30AM to load the network, and we run the

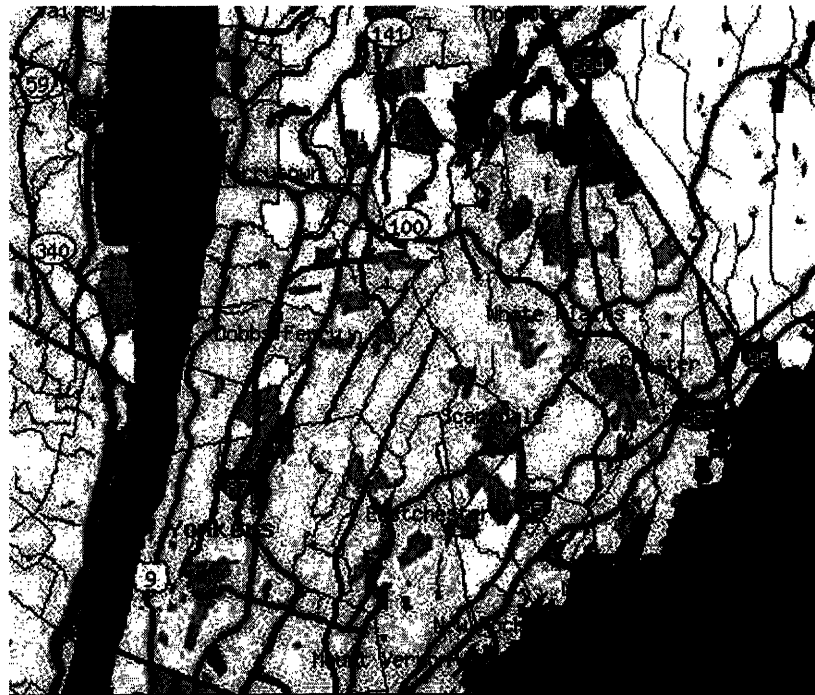

Figure 5-1 Lower Westchester Country Network Area

simulation until 10:00 AM so that the vehicles under consideration have enough time to complete their trips.

5.2 Calibration Results

The first step of the ATIS evaluation methodology presented in section 3.4.1 is to calibrate the DynaMIT and MITSIM traffic simulation software. Prior calibration of DynaMIT was performed on this LWC network for planning applications by Chauhan,

2003. Habitual demand and historical travel time databases were available from this calibration effort. The original data set included 58 usable surveillance sensors (Chauhan, 2003).

The demand as calibrated for the DynaMIT planning application by Chauhan resulted in extensive bottleneck situations in the MITSIM microscopic simulator, so demand was reduced uniformly across the study period (6:30AM to 10:00AM) in order to approximate realistic road conditions. An off-line DynaMIT demand calibration process was performed in order to develop a new historical demand database for DynaMIT. The results are shown in Figure 5-1.

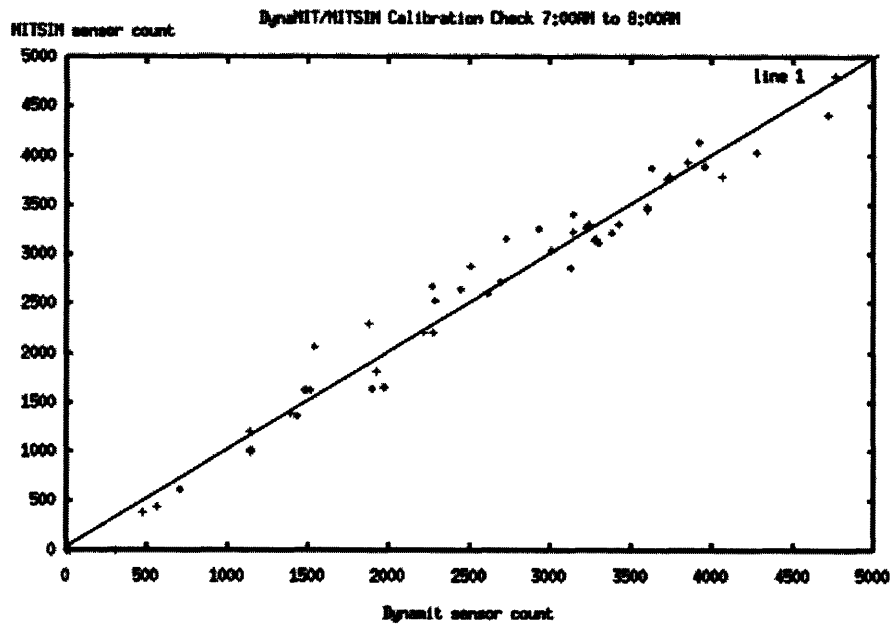

Figure 5-1 DynaMIT/MITSIM Calibration Results

Figure 5-1 shows correspondence between the MITSIM and DynaMIT surveillance counts reported on each of 58 sensors in a base case scenario (no incident, no guidance). The 45 degree line through the origin represents a good calibration – when the newly calibrated habitual demand is used in DynaMIT, the resulting sensor counts match the MITSIM surveillance very well. To quantify the fit, we compute the simulation error statistics described in section 4.1. The results over the existing 58 sensors are very good, and are summarized in Table 5-1.

The RMS % Error for the performed calibration was 1.1%.

Root Mean Square Error	Root Mean Square % Error	Mean Simulation Error	Mean % Error
228.49 veh/hr	1.1 %	-0.545 veh/hr	-3.97e-04 %

Table 5-1 – LWC NY Network Calibration Results

5.3 Baseline Performance

The baseline performance of the LWC network with no guidance under incident and non-incident conditions was established through simulation using the ATIS evaluation framework described earlier in this thesis.

ATIS was not made available to the driver population in order to establish baseline performance under recurrent and non-recurrent (incident) traffic conditions. Because the LWC network is so large, we restrict our analysis to only those drivers traveling between origin-destination pairs affected by the designed incident. This is illustrated in Figure 5-2. The designed incident affects the south-bound lanes on I-87, which is primarily loaded from traffic originating from nodes numbered 1, 2, 3 and 4, and destined for nodes 5, 6, and 7.

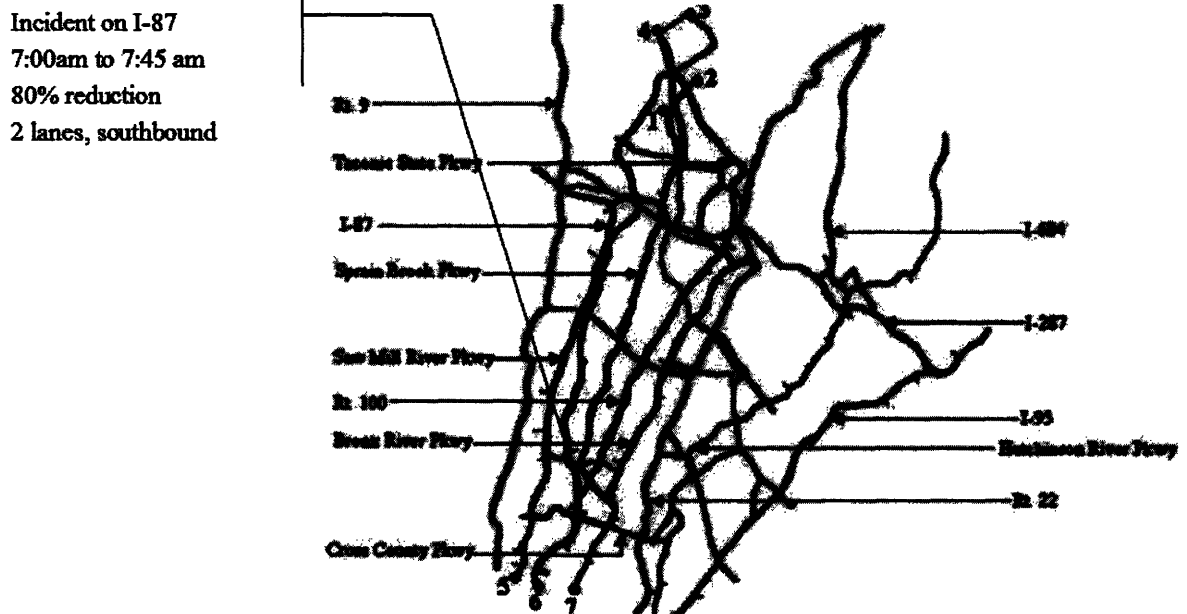

Figure 5-2 MITSIM Network Representation and Incident Location

5.3.1 No Incident

With no incident, the network performance for drivers between origins 1, 2, 3 and 4 and destinations 5, 6 and 7 is shown in Figure 5-3. There is little difference between the travel times for drivers between these destinations. Vehicles that departed between 7:30AM and 8:00AM faced the biggest delays. There were 6526 vehicles that departed between 6:30AM and 9:00AM and completed a trip by 10:00AM.

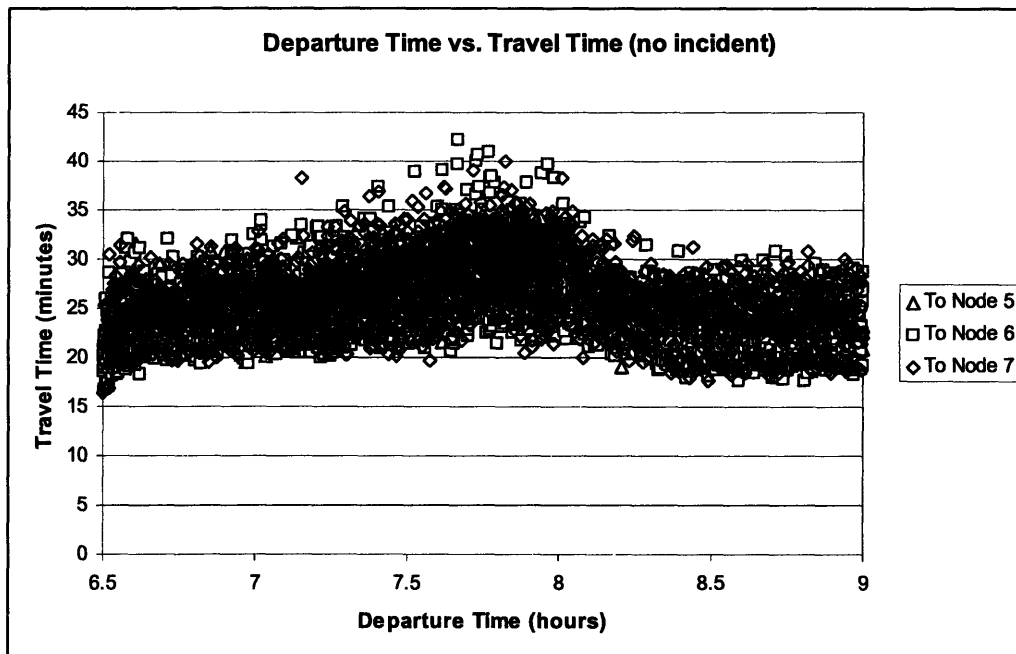

Figure 5-3 Departure Time vs. Travel Time No Incident LWC Scenario

The average travel times and sample standard deviations are:

	To Node 5	To Node 6	To Node 7
Mean Travel Time	25.28 min	25.17 min	26.75 min
Std Dev Travel Time	3.26 min	3.52 min	3.76 min

Table 5-2 Summary Statistics for No Incident LWC Scenario

5.3.2 Incident

With the incident designed as described in Figure 5-2, the network performance for travelers from origins 1, 2, 3 and 4 to destinations 5, 6 and 7 is degraded significantly,

as shown in Figure 5-4. Those vehicles that travel on the affected region of I-87 are delayed in queue until the incident clears at 7:45AM. These drivers face the biggest delays. There were 6516 vehicles that departed between 6:30AM and 9:00AM and completed a trip by 10:00AM, ten less than the no incident scenario. These ten vehicles were still en route, delayed by the incident, at 10:00AM, and do not enter into the descriptive statistics below.

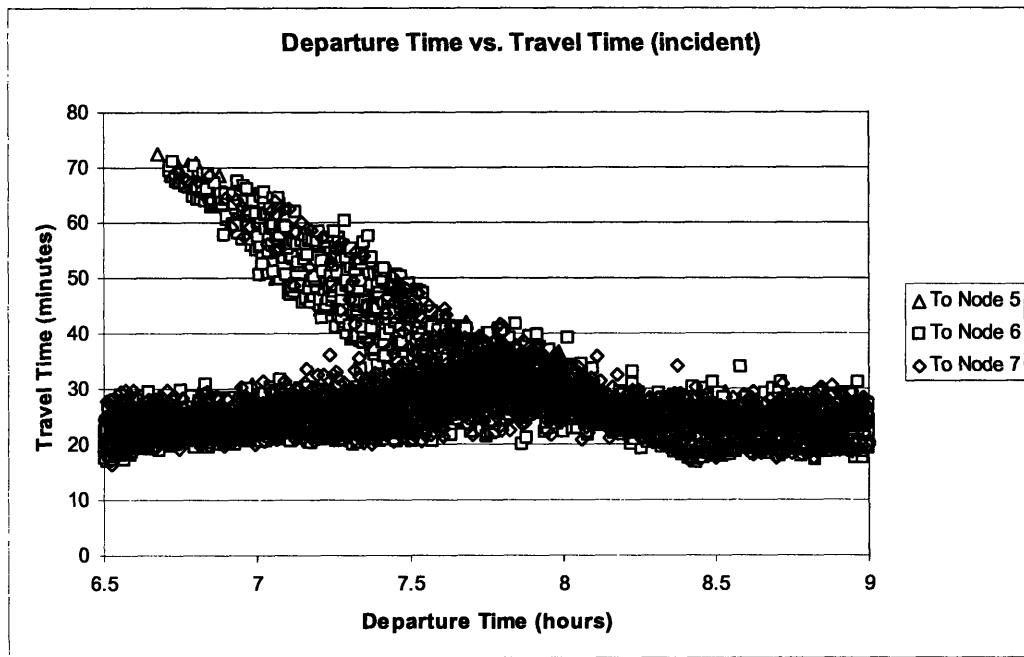

Figure 5-4 Departure Time vs. Travel Time Incident LWC Scenario

The average travel times and sample standard deviations are shown in Table 5-2. The sample standard deviations have increased significantly and the average travel time is now 10.3% higher than the no incident scenario.

	To Node 5	To Node 6	To Node 7
Mean Travel Time	28.6 min	28.4 min	27.9 min
Std Dev Travel Time	9.7 min	9.4 min	6.6 min

Table 5-3 Summary Statistics for Incident LWC Scenario

5.4 ATIS Performance

The impact of ATIS on this LWC network with only 58 sensors is not very good. Under a guidance scenario with 30% market penetration, the performance is substantially worse than the original incident case, as illustrated in Figure 5-5, Table 5-4 and Figure 5-6, below.

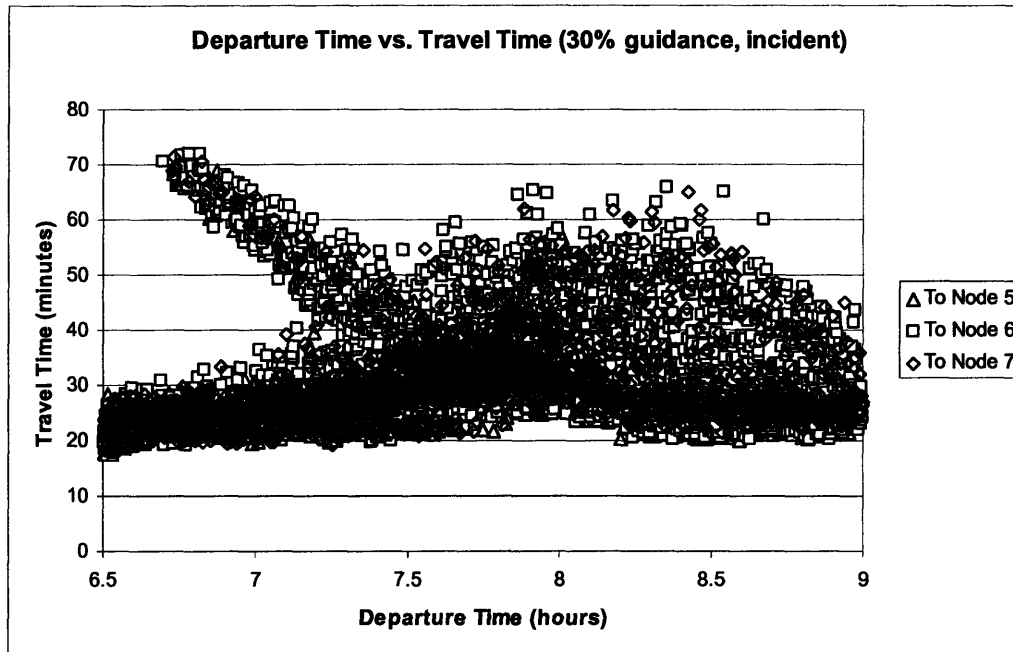

Figure 5-5 Departure Time vs. Travel Time, 30% Guidance w/Incident LWC Scenario

As compared to the Incident, No Guidance scenario, there are fewer vehicles that can be seen in the top-left 'tail' in Figure 5-5, indicating that fewer vehicles are queued behind the incident. However, the area between 7:30AM and 9:00AM shows significantly higher travel times for both guided and unguided drivers as a result of ATIS provision. Clearly, the guidance provided to drivers in this case was not consistent with network conditions. (We offer likely reasons for this in the next section.) However, there was some benefit to the drivers destined for Node 5. This group of drivers saw a 2.58% reduction in travel times (see Table 5-3), along with a slight reduction in sample standard deviation. However, this benefit was overshadowed by the worse performance of both guided and unguided drivers destined for Nodes 6 and 7.

	To Node 5	To Node 6	To Node 7
Mean Travel Time	27.8 min	33.2 min	31.2 min
% Change from Incident, No Guidance	-2.58%	+16.7%	+11.8%
Std Dev Travel Time	8.9 min	10.7 min	8.9 min

Table 5-4 Summary Statistics for 30% Guidance, Incident LWC Scenario

The system performance is also significantly worse under the 30% guidance scenario, as shown in Figure 5-6. Like the analysis of mean travel times, the drivers destined for Node 5 were the only group of drivers for which total travel time decreased. Overall, the total travel time under the 30% guidance scenario is higher than the incident scenario without guidance.

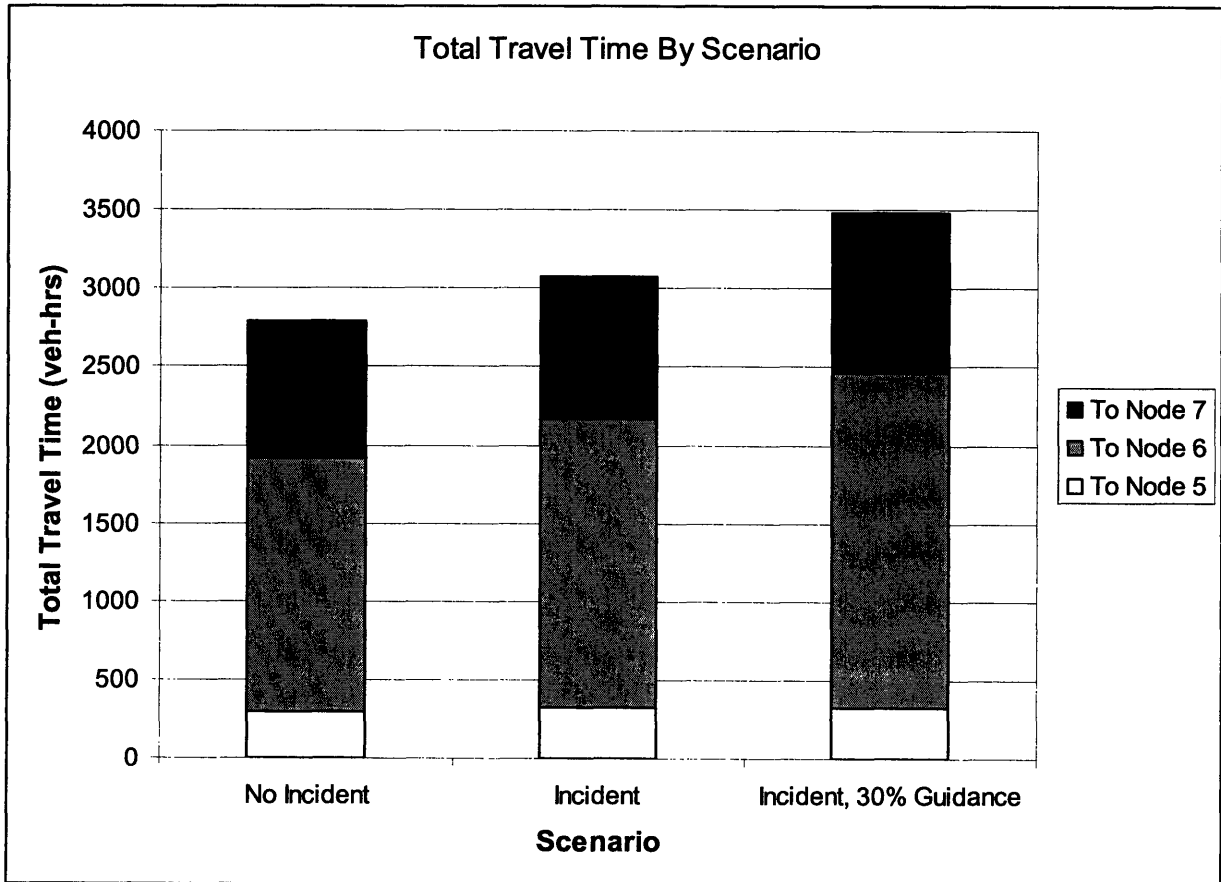

Figure 5-6 Total Travel Time By LWC Scenario

5.4.1 Discussion of Results

It is theoretically possible that the LWC network is being driven so close to capacity during peak-hour traffic that there is no room for accommodation of diverted vehicles on alternate paths; in such a case even consistent ATIS guidance would have no effect. But the lack of extra network capacity would mean that ATIS would have little to no impact – this does not in and of itself explain the deterioration of results from the no-guidance case. This section suggests and tests various hypotheses for improvement of DynaMIT ATIS quality.

The impact of ATIS in the LWC network is presently suboptimal for a number of reasons. We explore four main hypotheses to suggest remedies for the ATIS performance in this case study. They are:

1. Estimation and Prediction Iterations – DynaMIT must be configured with a maximum limit to the number of iterations that it will perform for OD estimation and guidance generation consistency (recall Section 3.2). Hypothesis: Increasing the maximum estimation and prediction iterations from 3 to 6 will improve ATIS performance.
2. Insufficient Surveillance Information – Given the large network (>1600 links), it is likely that the 58 available sensors do not convey enough information to accurately reflect the state of traffic. Hypothesis: Judiciously placing additional sensors would demonstrate ATIS performance improvements.
3. Lengthy Update Interval – A 15 minute information update interval may be too coarse for the rapidly changing traffic dynamics in this case study. Hypothesis: A 5 minute information update interval may improve ATIS performance over the 15 minute information update that was previously used.
4. Calibration Issues – While the simulation results for historical OD calibration in DynaMIT were very good, the calibration only occurred over the 58 available sensor locations (recall Section 5.2). Also, any calibration problems with the MITSIM ground-truth simulator would result in inconsistent guidance.

A simulation was run for each of the above hypotheses to provide an indication of which, if any, of these factors will offer the best focus for future work on this case study. The results are shown in Figure 5-7, below.

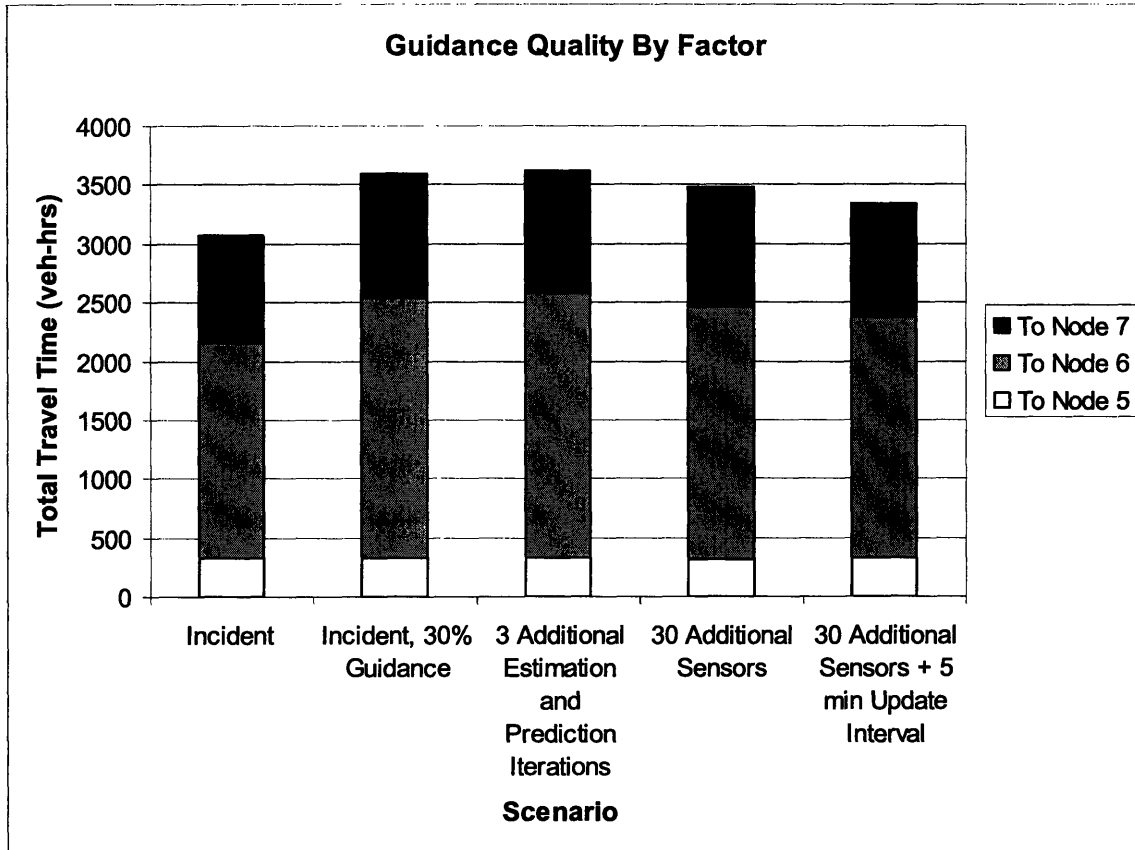

Figure 5-7 ATIS Guidance Quality By Factor

On a well-calibrated DynaMIT model we would expect that increasing the number of estimation and prediction iterations would improve guidance consistency by allowing for a better estimation of the traffic assignment matrix. However, increasing the number of estimation and prediction iterations in this case does not improve the quality of ATIS guidance. See Figure 5-7, “3 Additional Estimation and Prediction Iterations”. This result provides evidence that the DynaMIT model is not well calibrated against the MITSIM ground-truth simulator.

Another candidate for inconsistent guidance generation in the LWC scenario is the lack of properly placed sensors. The original fifty-eight road sensors available were highly clustered on the same routes. For instance, seven of the fifty-eight usable sensors

are on I-87, the route with the incident, and over ten sensors each are on I-95 and the Hutchinson River Parkway (See Figures 5-1 and 5-2). However, there are few sensors, if any, on the smaller routes adjacent to I-87, which are instrumental in handling traffic diverted from the incident. In order to test our hypothesis that increasing sensor coverage will result in an ATIS performance benefit, we have created 34 additional sensor locations that will be included in surveillance reports to DynaMIT. These additional sensors were judiciously chosen on routes adjacent to I-87. The ATIS performance, as measured by total travel time, improved by 3.2% when the additional sensors were included in MITSIM surveillance reports. This result offers rough confirmation of the intuition that additional surveillance will improve the quality of ATIS, but does not in and of itself explain the deterioration of network performance vs. the no guidance case.

Another factor that may contribute to the ATIS results is the 15 minute information update interval. Prior studies have documented that overreaction can arise with long information update intervals (Kaysi, 1992). In order to test the hypothesis that a shorter information update interval will improve ATIS performance, a simulation was run with an information update interval of 5 minutes. When the 5 minute information update interval is used in conjunction with additional sensors, the total travel time experienced by all drivers was reduced from the original guidance scenario by 6.9%. This evidence supports the hypothesis that a shorter information update interval is beneficial to guidance quality, but, again, does not in and of itself explain the poor guidance performance.

None of the above factors can account for the inconsistent guidance generation on this version of the New York Lower Westchester County network. However, there is evidence that the MITSIM ground-truth simulator is not yet calibrated properly. Current simulation results show that MITSIM drivers have a slightly different path choice set from DynaMIT drivers. This is likely due to discrepancies in network representation between MITSIM and DynaMIT, and current work is now underway to re-work the MITSIM network topology according to better GIS data. We expect that a new run of the ATIS simulation framework on the corrected MITSIM network topology will show better results. Again, work on the LWC network is currently underway to address these issues.

Chapter 6

6 Lessons for ATIS Deployment

The objective of this chapter is to use the results of the ATIS simulations presented in this thesis to inform the positions of real-world stakeholders with respect to the dynamics of ATIS deployment. This chapter returns to the questions raised in section 1.2 of this thesis, and attempts to build a conceptual model to characterize the value of ATIS, to anticipate and debate the potential need for regulation, and to determine effective ways to organize the imminent ATIS market.

6.1 ATIS Providers and Consumers

As outlined in section 1.2, ATIS service providers (TSPs), are profit-maximizing entities. There are many possible revenue-generating models for a TSP firm: they may charge consumers directly, sell traffic advisory services to radio stations who re-sell the information in exchange for advertising revenue from ratings, or partner directly with cell phone companies. (Undoubtedly, other models exist, including OEM ATIS equipment from car manufacturers.) Nevertheless, TSPs all sell information, and will be subject to the economics of the information they sell: specifically, TSPs need to understand that the production and dissemination of information is characterized by high fixed costs and low variable costs. In the Internet age, it costs TSPs virtually nothing to broadcast their ATIS, but the development, configuration, maintenance and operation of TSP systems to produce ATIS will be much more expensive. Based on these initial economics, it would seem that the road to profitability for TSPs is to sell information to as many subscribers/customers as possible; if the marginal cost of selling an additional unit is zero (or close to zero), and the price that the market supports is greater than zero, increasing customers will increase profitability.

6.1.1 ATIS Supply and Demand

But what if the price that consumers are willing to pay for ATIS does not remain constant with the number of subscribers? As noted in section 4 of this thesis (recall Figures 4-3 and 4-7) the benefits to consumers are not necessarily constant as market penetration increases. In this way, ATIS behaves not only according to the economics of information, but also according to the economics of congestion, characterized by a negative externality; after a certain market penetration, we can expect that ATIS value to guided drivers will drop with the number of network subscribers. Figure 4-7 is included again here for ease of reference. (Please refer to section 4.3.3 for a complete discussion of this figure.) After a market penetration of 30%, the time benefits to guided drivers drops significantly.

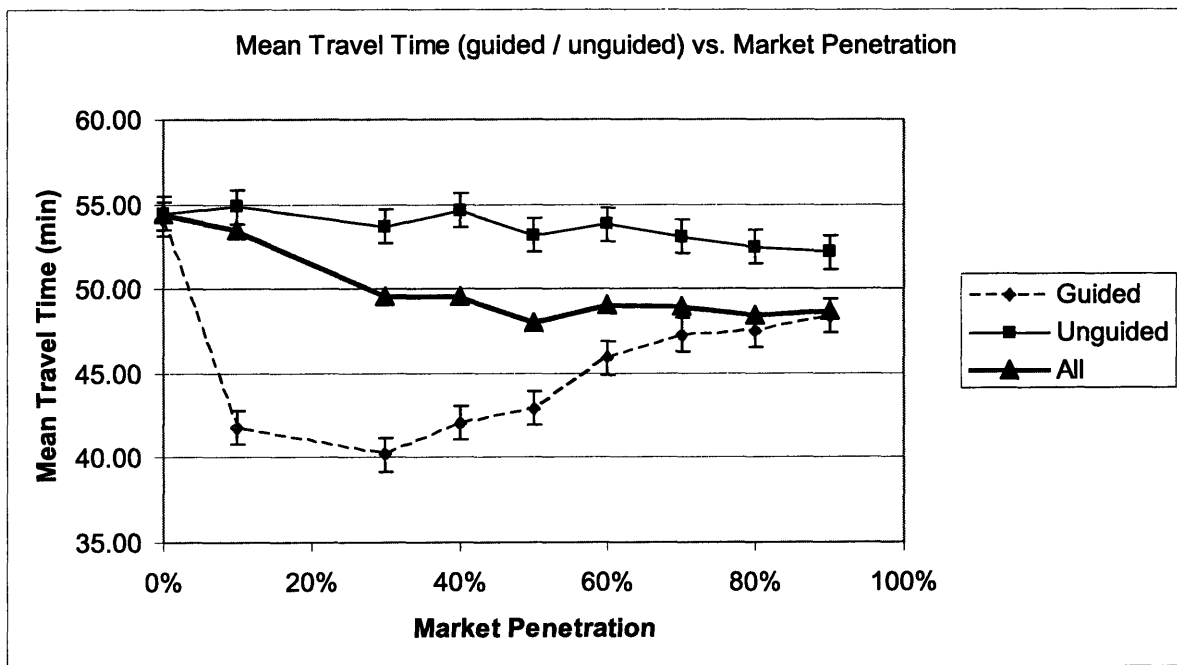

Figure 6-1 Degradation of Mean Travel Time to Guided Drivers

Other studies have confirmed this result. In Figure 6-2, Balakrishna (2004) reports an effect that is possibly more severe – not only does the mean performance of guided drivers drop after a 70% market penetration, but the drop is so significant that the

average performance to *all* drivers is also degraded. Note also the sensitivity to the information update interval.

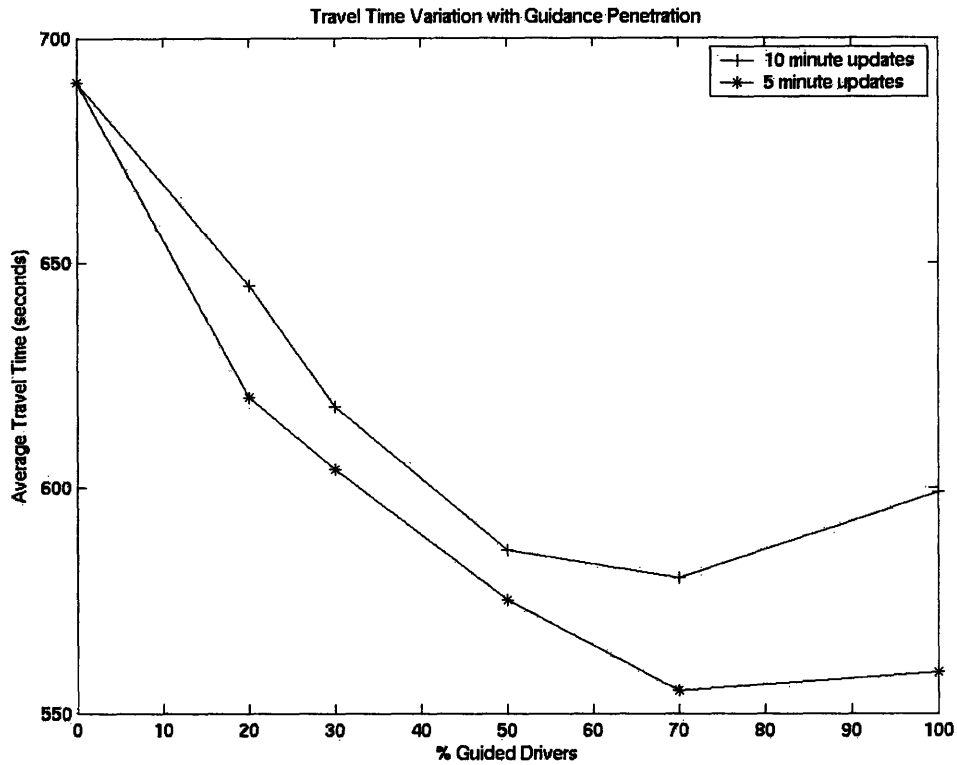

Figure 6-2 Degradation of Average Travel Time with Increasing Market Penetration (from Balakrishna, 2004)

Indeed, if alternate supply is a scarce resource in a given network, then there will most certainly be diminishing benefits to additional ATIS subscribers as drivers find that their alternate routes are already congested from prior diverted traffic. (Note that this does not mean that additional subscribers do not benefit the system as a whole – more on this later.) These results do suggest that there may be an eventual public role for regulation of ATIS provision to maintain optimal conditions.

Of the utmost importance, and a point often lost in the ATIS literature, is that these results refer specifically to predictive guidance from a dynamic traffic assignment system like DynaMIT. As discussed in the literature review, real-time/instantaneous

guidance exhibits even more pronounced overreaction effects. Consistent predictive guidance is more desirable for both guided and unguided drivers than simple real-time/instantaneous information.

Some academics (Lo, Szeto (2002), Yin, Yang (2002)) have performed analyses that attempt to determine willingness-to-pay (demand curves) for ATIS from the benefits of travel time alone, but this is possibly a misguided effort. While the approach of a mixed equilibrium between three parties (service provider, consumer, government) is a useful model, realistic willingness-to-pay figures for ATIS involve many factors (some of which are notoriously difficult to quantify), including benefits from increased reliability, psychological factors (peace of mind / expectation setting), and the ability to better plan trips and/or organize events around late-breaking traffic conditions. Even the perception of ATIS as a luxury item may have an impact on willingness-to-pay. For this reason, determining ATIS demand in order to compute an equilibrium with the established ATIS supply is entirely beyond the scope of this thesis. Nevertheless, it would seem likely that the actual willingness-to-pay for ATIS would correspond to the marginal travel time benefits available to the individual. Thus, the negative externality exhibited by ATIS could serve to limit the market upside to TSP firms.

A useful, if limited, analog for the long-term sustainability of ATIS is the market for financial information. Financial information, like ATIS, offers diminishing returns as market penetration increases; the first informed investors will remove market opportunities under the theory of efficient markets. But firms providing financial information have coped quite well by providing tiered services through price discrimination. Low-end subscribers may have to deal with an artificial delay in information update frequency and/or quantity, while high-end subscribers who pay more get faster information updates, better data quality, and perhaps access to more sophisticated analytics. Varian (1999), who calls this artificial service differentiation *versioning*, compiles a list of possible version dimensions. Such a tiered offering is a likely marketing strategy for ATIS providers that will help to keep the biggest value proposition with the best customers. However, versioning of public information, for example medical records, is often perceived to be in poor taste. An alternate view is that

the public will perceive route guidance information as a public resource that should not be subject to price discrimination tactics.

Oh and Jayakrishnan (2002) describe another strategy that TSPs may use to cope with the negative externality inherent in ATIS. The strategy involves using a TSP firm's existing subscriber base to improve the quality of surveillance information available to the firm, and to provide competitive advantage. If subscribers are already equipped with on-vehicle wireless communications devices, they may collect 'probe' traffic data from subscribers and build a proprietary database of traffic information. This type of service would become more valuable with the number of subscribers, and might be characterized by a tipping point; if one TSP firm were to capture enough of the market, other firms would have a very hard time competing due to network externalities.

6.1.2 ATIS Technology Deployment

North American TSP firms today face a dearth of good quality surveillance information. This is a significant gap in the supply chain for TSP firms, and partially explains why North American efforts in this area lag behind related Japanese and European efforts. To illustrate this gap in terms of the National ITS Architecture, consider the market package description for Dynamic Route Guidance, below. The 'Traffic Management' module that is responsible for providing road network conditions is either non-existent or underdeveloped in most parts of the country.

ATIS4 – Dynamic Route Guidance

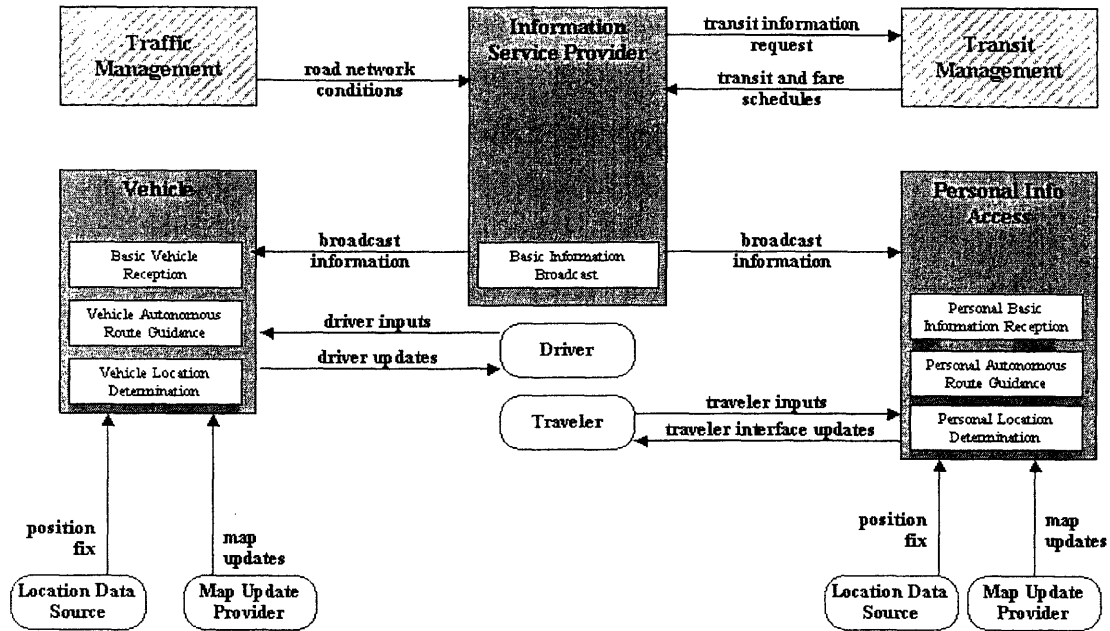

Figure 6-3 National ITS Architecture Dynamic Route Guidance Market Package

Oh and Jayakrishnan (2002) list three main reasons why North American TSPs have not yet reached the anticipated level of market penetration:

1. The underlying product – real-time traffic information – cannot be manufactured in a controlled environment
2. The data are variable in scope and quality and are provided in non-standardized format
3. No established consumer market exists for real-time traffic information other than radio broad(cast) reports

The third point seems to be an effect of the first two: the lack of an established market is likely due to the fact that while there are federal research programs underway at the level of dynamic traffic assignment systems to generate predictive guidance, government spending has been extremely poor on the enabling infrastructure. Simply put, there is a lack of reliable traffic monitoring systems to support dynamic route guidance in practice.

Undoubtedly, better network sensor coverage would allow us to improve the quality of ATIS. While a study of public/private partnership to reach these goals is beyond the scope of this thesis, this is clearly a development point on which a world-stage ATIS market depends.

To add anecdotal evidence to the second point in the claim by Oh and Jayakrishnan, a report by the consulting firm of Booz-Allen & Hamilton on the SmarTraveler real-time ATIS service stated that “the integration and processing of traffic information from various sources can be very hectic at times, and is more art than science...Cooperative arrangements have been reached with other local public transportation institutions, but despite the government’s financial involvement... these organizations view SmarTraveler as just another media outlet, rather than as an instrument of public policy deserving of special treatment...” (Booz-Allen (1994)).

Given the sensitivity of dynamic route guidance to sensor location and accuracy (see discussion in section 5.4.1), this is an organizational issue that successful TSPs will need to address.

6.1.3 ATIS Taxonomy

One of the common mistakes made by ATIS analysts is that not all ATIS is created equal. In fact, it is useful to consider a spectrum of information ranging from real-time/instantaneous information to predictive information of various accuracies. Firms providing ATIS at different levels of the information spectrum provide radically different qualities of service. Beinhaker (2004) has created an ATIS spectrum matrix as a tool for such a discussion. See Figure 6-4.

		Time-period spectrum			
		None	Historical	Instantaneous	Predictive
Time-update spectrum	None	None/None			
	Pre-trip		Static/ Historical	Pre-trip/ Instantaneous	Pre-trip/ Predictive
	En-route		Time Dependent/ Historical	En-route/ Instantaneous	En-route/ Predictive

Figure 6-4 ATIS Information Spectrum (from Beinhaker 2004)

Beinhaker (2004) distinguishes between the time update spectrum of en-route and pre-trip ATIS, as well as the time-period spectrum of historical, instantaneous (real-time) or predictive information. If each ATIS performance ‘review’ clearly discussed the nature of the ATIS under evaluation according to this matrix, we would avoid much of the confusion related to establishing a baseline benefit of various forms of ATIS. Nevertheless, while it is clear what is meant by ‘historical’ or ‘real-time’ information, it is not so clear what is meant by ‘predictive’ information. Beinhaker’s study uses an *a posteriori* methodology that allows him to use perfect information as prediction, but in the real-world there are an infinite number of traffic predictions.⁷ Again, we must be careful to distinguish between the effects of different kinds of predictive ATIS.

The low-hanging fruit for current TSPs is to provide instantaneous information in lieu of more sophisticated, theoretically consistent predictive information. The biggest documented issue with the provision of real-time ATIS (as opposed to dynamic route guidance) is that there is no way to account for the overreaction phenomenon. The guidance does not incorporate the probabilistic route choice of drivers, and may result in

⁷ Clearly, anyone could come up with a million distinct, arbitrary prediction models for traffic, some of which could have absolutely no bearing on traffic whatsoever. We must be careful to describe exactly what type of ‘predictive’ ATIS we are talking about.

wide swings in traffic performance past early market penetrations (Kaysi, 1992). However, for TSPs today it may be possible to assume that guided drivers will not 'move the market' since early market penetration rates will be so small. This may be an issue that can be successfully put off until ATIS becomes more pervasive.

6.1.4 Marketing ATIS

Marketing ATIS is notoriously difficult due to an Olsonian collective action dilemma. The results from the ATIS Evaluation in Chapter 4 shows that while there are tangible travel time benefits to the individual, the benefits on an individual level may not be perceived as sufficient to justify the purchase of an in-vehicle navigation device and/or associated service.

For example, in the high demand scenario in Chapter 4, the maximum benefit from ATIS was fifteen minutes on a fifty minute commute, and this is an extreme case due to the simple network topology under study. Transportation professionals often compute an individual's value of time during car trips. A convenient rule-of-thumb is that an individual's value of time (for trips to/from the office, at least) should be roughly equivalent to foregone income from working that same amount of time. As a loose calculation, a traveler who makes US\$60,000/yr makes an hourly income of roughly US\$20/hr. The fifteen minutes of time savings on a bad commute, then, will monetize to only US\$5. The point is that TSPs will have a difficult time marketing ATIS by monetizing benefit from time savings from alone, even if they can reliably show regular time savings. Using the cost of in-vehicle GPS devices as a proxy for the cost of in-vehicle ATIS devices, TSPs will need to justify hundreds of dollars of benefit from ATIS, not tens.

As a result, TSPs are beginning to target concentrated interests to overcome the collective action problem. ATIS solutions targeting fleet management/logistics issues are developing much more convincing marketing plans. See Beinhakr (2004) for an argument that values a predictive ATIS service to a sample regional carrier trucking firm at more than \$US 1MM/yr.

6.2 ATIS Public Interests

Section 6.1.2 discussed the importance of public involvement in ATIS deployment, and listed one of the failures of the North American ATIS market as lack of proper public involvement. This is ironic, since the benefits of ATIS from a public perspective are even more tangible than from the private perspective.

Reduction of system-wide travel time will not only benefit the quality of service over portions of existing transportation networks, but also save fuel consumption and, help with pollution. The benefits from fuel consumption and pollution are beyond the scope of this thesis, but deserve mention regardless.

The ATIS Evaluation studies in this thesis inform four main public issues surrounding ATIS. First, the studies show the great potential that ATIS still has for improving the efficiency of already-existing infrastructure. Second, the results show that the distributional effects of ATIS do not leave unguided drivers worse-off, even if they do not benefit as much as the guided drivers. Third, the results point to the high sensitivity of ATIS performance on regional factors, indicating that proper management of ATIS may require an integrated, but regional, jurisdiction. Finally, the studies show that ATIS should not be viewed merely as a superfluous add-on to an existing transportation infrastructure. The ability of ATIS to greatly increase network performance (or harm it) implies that government should evaluate ATIS projects directly alongside infrastructure and ATMS investments, not as a distinct private-sector concern.

6.2.1 ATIS System Performance

While the benefits to an individual ATIS subscriber will likely be only a few minutes per commute, on average, the system benefits from increased network performance can be staggering. Take the simple high-demand scenario presented in Chapter 4. The summary of results is presented again here:

Market Penetration	Total Travel Time (veh-hrs)	Total Travel Time Savings
0%	3628	N/A
10%	3564	1.8 %
30%	3305	8.9 %
50%	3197	11.9 %
70%	3267	10.1 %
80%	3230	10.98 %
90%	3250	10.44 %
100%	3331	8.9 %

Table 6-1 Simple Network High Demand Total Time Savings Due To Incident

In this simple case, a 30% market penetration of dynamic route guidance ATIS resulted in a savings of 3305 vehicle-hours over only a 1 hour time interval. If we again follow the simple logic from section 6.1.4, assuming a very rough \$US 20/hr value of time for drivers drivers, this relates to a US\$66,100 savings over the unguided case for just an an hour of commute time on a tiny network. ATIS clearly offers hope for recovering at least the non-recurrent portions⁸ of the US\$72 billion/yr congestion problem⁹. And if private firms are fighting against a collective action dilemma, it would seem that the public, too, would benefit from a solution. While public funds have been allocated in the past to fund marginally successful ATIS efforts, there is clearly still a role for government to play in the facilitation of ATIS.

This is not to say that ATIS will always confer system benefits. ATIS guidance that is not yet properly calibrated for an application can easily provide detrimental effects to system performance, as encountered in the case study on the Lower Westchester County, NY network. Those results are presented again here in Figure 6-6. Note that the total travel time under the 30% guidance scenario is far worse than the incident case with

⁸ To repeat, ATIS will only help with congestion that is non-recurrent, or congestion that results from inaccurate driver perception of alternate routes. In traffic conditions already approximating user optimal conditions, ATIS will not be expected to have much effect.

⁹ Figure from the Texas Transportation Institute

no guidance. Therefore, it will be absolutely necessary for public interests to develop some way to evaluate and certify any ATIS proviers in the same way as planners investigate the impact of changes to new infrastructure. Ultimately, public transportation departments should require standardized quality of service audits to be in place with any Traffic Service Providers operating in the region. However, debate over such regulation can wait until ATIS firms develop enough of a market penetration to actually affect system performance. Even if market penetration reaches significant levels, it remains to be seen how drivers will incorporate the new information into their decision-making. Even if a large proportion of drivers subscribe to ATIS, they will only use the guidance if it is easy to use and perceived to be meaningful. Without such circumstances, system benefits from ATIS may not materialize.

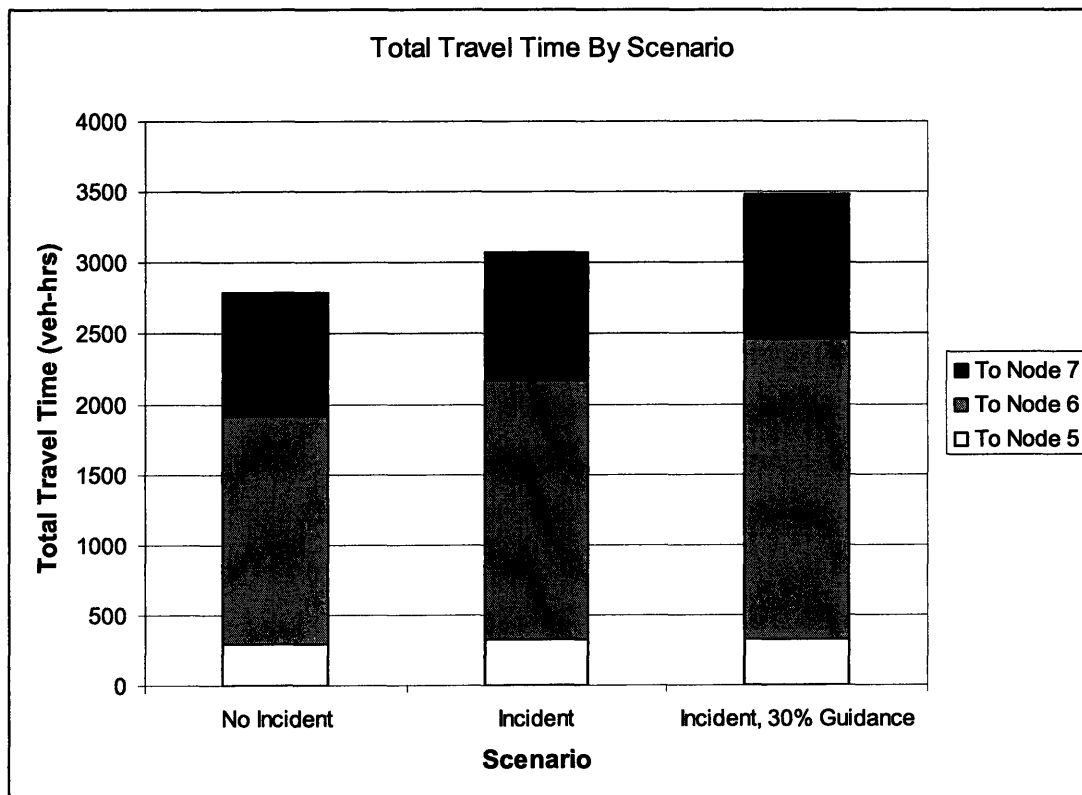

Figure 6-5 Possible Misuse of ATIS

There is also a regulatory issue concerning optimal performance of ATIS. As discussed in section 6.1.1, there is the possibility for an inflection point in the quality of ATIS service, where total travel time actually increases past a certain critical point of

market penetration. But regulation of optimal ATIS performance around this inflection point is not more than an interesting theoretical issue at this point. When the ATIS market matures to the point that market penetration is a candidate for regulation, there will likely be a slew of new information to consider.

6.2.2 Distributional Considerations

While the government’s skepticism concerning the value proposition of ATIS is a big concern, another potential barrier to public involvement in ATIS deployment is the perception that ATIS is a luxury service that will benefit only paying subscribers. The results presented in this thesis hopefully serve to dispel this perception.

Recalling results from Chapter 4, we saw that ATIS can significantly increase the performance of unguided drivers as well as guided drivers.

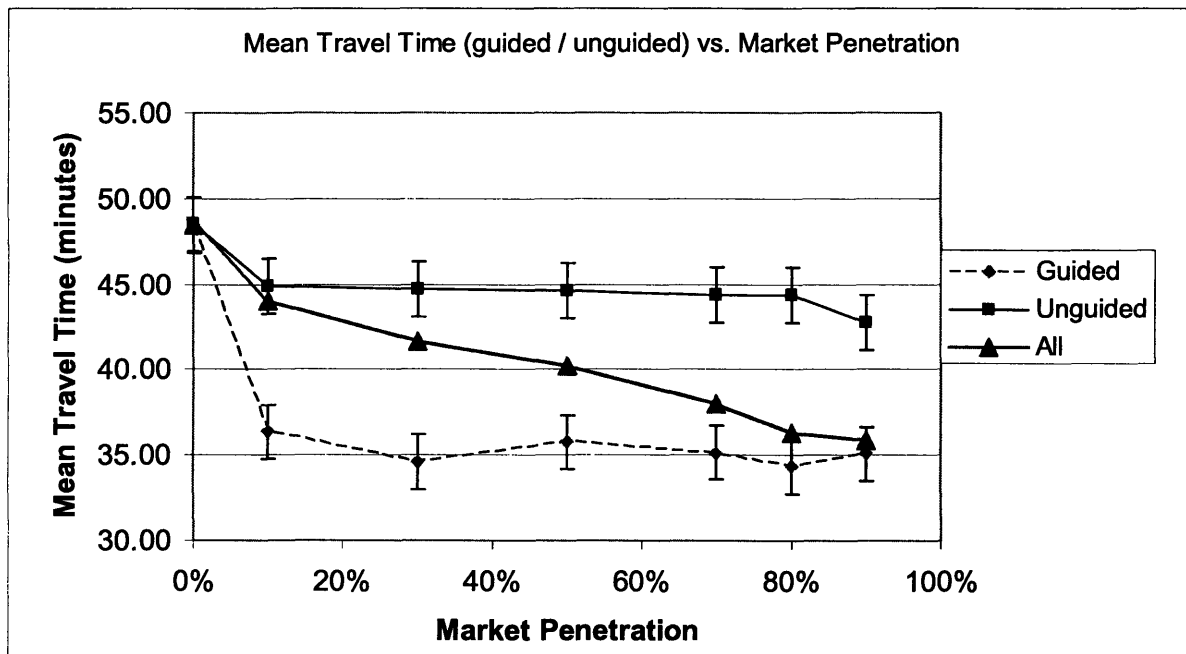

Figure 6-6 ATIS Benefits Unguided Drivers As Well as Guided

Much has been made of the inadequacies of supply-side solutions to the congestion problem, and experts agree that demand-side solutions are required to increase long-term quality of service on transportation infrastructure (Downs, 1984). But demand-side management techniques often come under public scrutiny for equity issues. For instance,

congestion pricing through the use of tolls discriminates against the poor: since less wealthy individuals are more elastic to price hikes, pricing road use under peak-hour travel will force them to travel at less-convenient times, while allowing high-income individuals to use the roads at their convenience (and at a price, of course).

The use of ATIS as a demand-side traffic management technique is a kinder, gentler alternative to congestion pricing. Since unguided drivers do reap some reward from good ATIS provision to guided drivers, there is little to complain about in terms of a distributional equity issue. At the very least, they will not be worse off than they were before an ATIS market. Of course, this does not guarantee that they will not complain. While unguided drivers would likely benefit from the provision of predictive ATIS, they may still find it offensive that ATIS equipped drivers benefit more. Ultimately, this issue is a question of whether the public will perceive ATIS as a public resource, in which case price discrimination schemes will likely be seen to be in poor taste.

6.2.3 Regional Evaluation

As seen in Chapters 4 and 5, the impact of ATIS is extremely sensitive to the network topology, habitual demand characteristics, route-choice behavior of local driver population and local surveillance/sensor locations. As a result, it will be near impossible to make accurate nation-wide forecasts of ATIS benefits for value proposition arguments in order to secure funding. Instead, regional evaluation studies, and regional planning of ATIS, should be conducted.

Fortunately, the tools required to study the impact of ATIS are ones with which the transportation planning community is already familiar. Using evaluation frameworks for ATIS, like the one developed in this thesis, regional studies should give accurate results as to the impact of ATIS under local demand characteristics on local road networks. Such studies can guide the allocation of scarce public resources through marginal analyses on new surveillance/sensor deployments, and can rationally justify new ATIS projects, and spending on public-private partnerships at the regional level.

Chapter 7

7 Conclusion

Drivers using dynamic route guidance from an Advanced Traveler Information System (ATIS) could potentially make better travel decisions to reduce travel time and increase trip reliability, thereby benefiting both guided drivers as well as those without such access. Moreover, such ATIS could provide substantial system-level benefit as well as benefit to individual travelers. The results in this thesis confirm these statements. Therefore, the prospect of using ATIS to improve the quality of service of congested surface transportation networks is a real one, and ATIS should be considered alongside conventional infrastructure expansions and ATMS as ostensible solutions.

Specifically, the results from the first case study confirm a number of results from the literature. First, the provision of predictive ATIS is sensitive to demand characteristics on a given network. In the low demand scenario, the simple network performance was improved by a maximum 28% of total travel time at 100% ATIS market penetration, while the maximum benefit in the high demand scenario was only 12% at 50% ATIS market penetration. Second, the results confirmed the presence of overreaction in the high demand scenario, but not in the low demand scenario. Third, the results confirm that the provision of consistent, predictive ATIS can reduce travel times for both unguided and guided drivers, with the guided drivers enjoying most of the benefits. Finally, the results confirm that guided drivers also experience benefits in terms of trip reliability.

However, this thesis also shows that the provision of poor guidance can significantly deteriorate network performance, just as poor ATMS or poorly designed conventional infrastructure can cause problems. The use of ATIS to improve traffic conditions, then, should come under public scrutiny once market penetration becomes high enough to affect system-wide performance.

Specifically, the results from the second case study suggest that further work is needed to calibrate the Lower Westchester County, NY network. Four factors were investigated, including DynaMIT computational resources, information update interval, and surveillance network coverage. While shortened information update interval and increased sensor network coverage showed improved quality of ATIS, it is unlikely that these factors alone are responsible for inconsistent guidance.

Not all ATIS is equally viable. This thesis studies predictive guidance generated from the DynaMIT dynamic traffic assignment system, with all the characteristics exhibited by this simulation tool. These results are not necessarily extensible to the provision of instantaneous information, nor are they necessarily extensible to other dynamic traffic assignment systems used to generate predictive guidance.

The growth of the nascent ATIS holds many challenges for private firms interested in providing dynamic route guidance, not least of which are: 1) establishing concentrated interests to purchase ATIS services, 2) successfully organizing an underlying surveillance and communications infrastructure to effectively source real-time traffic data, and 3) overcoming the idiosyncrasies of the economics of ATIS information presented in this thesis.

Likewise, the growth of the ATIS industry is dependent upon public organizations for a number of roles. Government will need to provide critical facilitation with regards to quality requirements and standards for traffic information. Public interests will also need to scrutinize the private deployments of regional ATIS providers to ensure that private-sector guidance does not adversely affect the performance of public infrastructure. These efforts, as well as any public funding for dynamic route guidance services will be best accomplished in an integrated, but regional, organization due to the high sensitivity of dynamic route guidance to local factors such as network topology, demand characteristics, and driver behavior.

7.1 Thesis Contributions

There are two main contributions from this thesis.

First, this thesis contributes a newly developed ATIS Evaluation Framework and associated methodology for synchronous operation of the DynaMIT dynamic traffic assignment system and the MITSIM microscopic simulator. This system allows analysts to perform analyses on the impact of dynamic route guidance to a synthetic driver population. This application will be useful for planning and managing the effective deployment of dynamic route guidance ATIS.

Next, this thesis documents a number of evaluation case studies using the new ATIS Evaluation Framework to evaluate the impact of ATIS in various circumstances. While this thesis does not claim to conduct an exhaustive sensitivity analysis of ATIS across all dimensions, it does confirm some prior results from the literature, and serves to illustrate the anticipated user and system performance of Advanced Traveler Information Systems as part of the transportation infrastructure.

Finally, the ATIS case study results offer a number of insights for the public and private stakeholders concerned with the development of a future market for dynamic route guidance ATIS. These lessons should be of interest to emerging private Traffic Service Provider firms hoping to offer dynamic route guidance services, as well as to public organizations that need to plan for and manage the effective deployment of ATIS.

7.2 Scope of Future Research

The author's work over the last two years has brought to light a number of initiatives for ongoing research.

First and foremost, the planning of ATIS services would benefit greatly from market research that could provide reliable demand curves for the growing industry. This would allow for a conventional economic welfare analysis to be performed on ATIS market(s) when combined with the supply-side work documented in this thesis and others like it. As mentioned in this thesis, the task of deriving willingness-to-pay for ATIS services that do not yet exist involves many criteria above and beyond the impact of ATIS on travel time and trip reliability.

Next, this thesis showed the sensitivity of ATIS to the location of appropriate surveillance units. The proper deployment of ATIS would benefit greatly from research on the effects of sensor location on dynamic route guidance validity.

The ATIS Evaluation Framework developed for this thesis could also benefit from a number of future developments. Any study using the DynaMIT dynamic traffic assignment system would benefit from an improved online and offline calibration methodology. The framework could also be extended to deal with an arbitrary update horizon to optimize the information update interval.

The Lower Westchester County, NY network is not yet calibrated the way it should be, and this is likely the primary reason for the generation of inconsistent guidance in the second case study presented here. Future work should be directed at validation of the LWC network coding and supply representation. When these issues are resolved, the ATIS Evaluation Framework presented in this thesis should be re-applied to investigate the potential benefits of ATIS.

Appendix A

Software Operation for the ATIS Evaluation Framework

This section describes operation of the ATIS Evaluation software presented in this thesis. The operation of the evaluation framework involves both the MITSIM and DynaMIT traffic simulators, and readers are expected to have read the corresponding user manuals.

Figure 3-11 is included here again to illustrate the interaction of DynaMIT and MITSIM during operation.

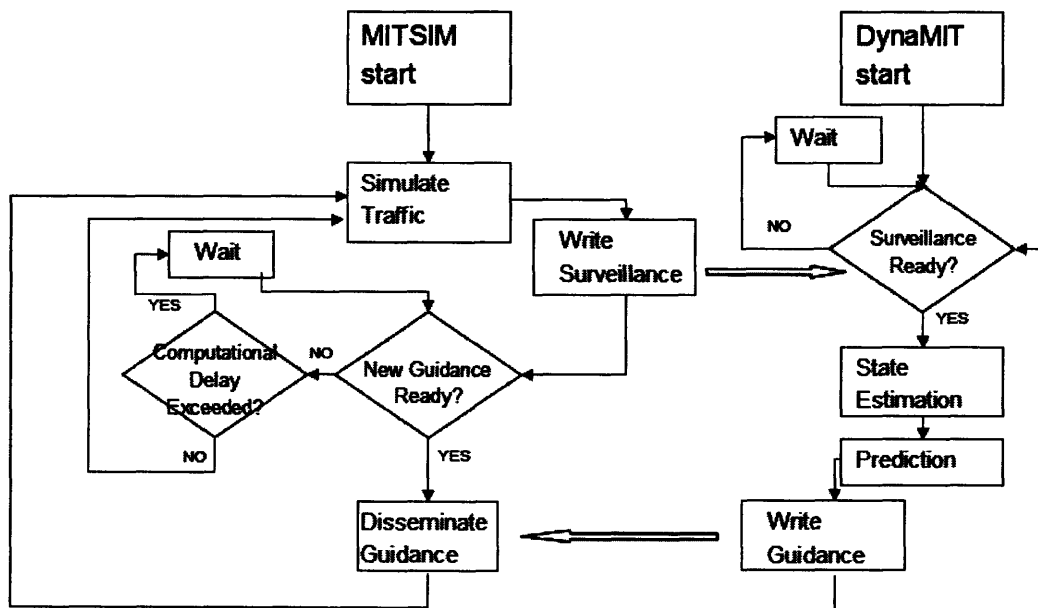

Figure A-1 ATIS Evaluation Framework: MITSIM and DynaMIT Operational Interaction

The MITSIM and DynaMIT configuration files have optional parameters that are used to control 'closed loop' operation of the ATIS Evaluation Framework. Without

these parameters MITSIM and DynaMIT will default to stand-alone, independent operation. Furthermore, there are existing MITSIM and DynaMIT configuration options that need to be standardized in order for proper closed-loop operation. In order to configure MITSIM and DynaMIT for closed loop operation, the following options need to be set: (Note: All other configuration options in MITSIM and DynaMIT are as specified in the corresponding user manual)

(MITSIM) In `master.mitsim`:

- `[ClosedLoopGuidance]` should be set with the path to the directory where DynaMIT is configured to write the ATIS guidance file. (Note: Both MITSIM and DynaMIT will need to have shared access to a common file system)
- `[Start Time]` should be set to correspond to the start of the DynaMIT simulation time. Note that DynaMIT will wait for MITSIM surveillance each OD Interval after the DynaMIT start of operation. If MITSIM is not started at an appropriate time to provide surveillance reports on this period MITSIM and DynaMIT will reach a deadlocked state.
- `[Stop Time]` should usually be set to correspond to the end of the DynaMIT simulation time. If DynaMIT stops before MITSIM, MITSIM will be blocked waiting for DynaMIT guidance. If MITSIM stops before DynaMIT, DynaMIT may be blocked waiting for additional MITSIM surveillance.
- `[Point Sensor Step Size]` should be set to match the DynaMIT OD Interval. Note that this parameter is measured in seconds, while the DynaMIT OD Interval is measured in minutes. (ie. 900 seconds = 15 minutes).
- `SP Flags` should be set to `0x105`. This configuration is needed for time-variant path calculation, periodic path table travel time updates, and pre-trip planning on updated travel times.

- [Output] should be set to `0x2353`. This will ensure that the vehicle log is written for performance analysis and that sensor readings are written for surveillance to DynaMIT. Other [output] configurations that account for both of these settings will also work.

(DynaMIT) In `dtaparam.dat`:

- `MitsimSensorsFile` should be set with the path to the directory that MITSIM uses to write the `sensor.out` surveillance report. (By default MITSIM writes this file into the Output directory.)
- `GuidanceOutputFile` should be set with the name of the guidance file that DynaMIT will write. This needs to correspond to the [ClosedLoopGuidance] MITSIM parameter described above.
- `StartSimulation` should correspond to the MITSIM [Start Time]. Please see above for more discussion.
- `StopSimulation` should correspond to the MITSIM [Stop Time]. Please see above for more discussion.
- `ODInterval` must correspond exactly (units in minutes) to the MITSIM [Point Sensor Step Size] parameter (units in seconds). See the discussion above for more details.
- `HorizonLength` should be 30 minutes. DynaMIT must provide header information describing the dimensions of the guidance table to MITSIM. Different `HorizonLength` values were not tested, but will work without further code changes provided that the dimensions of the guidance table are unchanged.

Once the DynaMIT and MITSIM configuration files are ready, closed-loop execution for ATIS evaluation case studies can be accomplished by starting both the MITSIM and DynaMIT executables in the normal manner. The order in which they are started is not important. **Note:** After a completed closed-loop simulation run, the output guidance and surveillance files must be cleaned or they will be used incorrectly in a subsequent run. The files that need to be removed are:

1. The DynaMIT guidance file, referenced by the [ClosedLoopGuidance] parameter in the master.mitsim file. (Eg: "rm -f output/closedloopguidance.out")
2. The MITSIM surveillance report file, referenced by the MitsimSensorsFile parameter in the dtaparam.dat file. (Eg: "rm -f Output/sensor.out")
3. The lock file used to ensure proper concurrency between MITSIM and DynaMIT during file-based read/write operations. This filename is created internally to be the filename referenced by [ClosedLoopGuidance] in the master.mitsim file, with the concatenation of a ".lck" concatenation suffix. (Eg: "rm -f output/closedloopguidance.out.lck")

The following is a sample master.mitsim file configured for closed loop operation with DynaMIT.

```

/*
 * MITSIM master file
 */

[Title] = "Local Ramp Control (Platoon)"
[Default Parameter Directory] = "~/simple"
[Input Directory] = "~/simple"
[Output Directory] = "~/simple/Output"
[Working Directory] = "~/simple/Output"
[Parameter File] = "paralib.dat"
[Network Database File] = "simple_reduced1.dat"
[Trip Table File] =
"/home/dflorian/simple/od.dat"
[Vehicle Table File] = ""
[Transit Network File] = ""
[Bus Schedule File] = ""
[Bus Run File] = ""
[Bus Assignment File] = ""
[Transit Demand File] = ""
[Bus Surveillance File] = ""
[State Dump File] = ""
[GDS Files] = {
%   Filename   MinScale   MaxScale
   "catkey.gds"   0       10
   "label.gds"   0       10
   "fun.gds" 0.2    10
   "wklayer.gds" 0.02   10
}
[Link Travel Times Input File] = {
   "linktime_reduced.in" # Historical travel time

```

```

    "" #linktime_instant.in" # Updated travel time
    0x105      # SP flags
    % 0x001 Time variant path calculation
    % 0x002 Calculate shortest path periodically
    % 0x004 Update path table travel time periodically
    % 0x008 Use existing (cached) shortest path table
    % 0x100 Updated travel time used for pretrip plan
    % 0x200 Receives updated travel time at beacon
}
[ClosedLoopGuidance]          =
"/home/dflorian/simple/output/closedloopguidance.out"
[Incident File]               = ""
//incident_mitsim.dat"
[Path Table File]             = "path.dat"
[MOE Specification File]      = ""
[MOE Output File]             = "moe.out"
[Network State Tag]           = "i3d"
[Segment Statistics File]     = "segstats.out"
[Segment Travel Times File]   = "segtime.out"
[LinkFlowTravelTimes Output File] = "lft_i.out"
[Link Travel Times Output File] = "linktime.out"
[Vehicle File]                = "vehicle.out"
[Vehicle Trajectory File]     = "trajectory.out"
[Transit Trajectory File]     = "transtraj.out"
[Bus Stop Arrival File]       = "busstop.out"
[Signal Priority File]         = "priority.out"
[Vehicle Path Record File]    = "pathrec.out"
[Departure Record File]       = "dep.out"
[Queue File]                  = "queue.out"
[Point Sensor File]           = "sensor.out"
[VRC Sensor File]             = "vrc.out"
[Assignment Matrix File]      = "assignment_matrix.out"
[Lane Changing File]          = "lane_changing.out"

[Start Time]                  = 06:50:00
[Stop Time]                   = 07:50:00
[Step Size]                    = 0.2

[Segment Data Sampling Step Size] = 60
[Segment Data Report Step Size] = 300
[Point Sensor Step Size]        = 900
[Area Sensor Step Size]         = 60
[Animation Step Size]           = 0.1
[Segment Color Step Size]       = 15
[Console Message Step Size]     = 60
[MOE Step Size]                 = 60
[MOE OD Pairs]                  = {
}

[Output]                       = 0x2353
% 0x000001 = Vehicle log
% 0x000002 = Sensor readings
% 0x000004 = VRC readings
% 0x000008 = Assignment matrix output

```

```

% 0x000010 = Link travel times
% 0x000020 = Segment travel times
% 0x000040 = Segment statistics
% 0x000080 = Queue statistics
% 0x000100 = Travel time tables
% 0x000200 = Vehicle path records
% 0x000400 = Vehicle departure record
% 0x000800 = Vehicle trajectories
% 0x001000 = Output rectangular text
% 0x002000 = No comments
% 0x004000 = Transit trajectories
% 0x008000 = Bus stop arrivals
% 0x010000 = State 3D
% 0x020000 = Priority events

% 0x040000 = Lane changing file
[Segments] = 2
% 0 = Link type
% 1 = Density
% 2 = Speed
% 3 = Flow

[Signals] = 0x32
% 0x01 = Traffic signals
% 0x02 = Portal signals
% 0x04 = Variable speed limit signs
% 0x08 = Variable message signs
% 0x10 = Lane use signs
% 0x20 = Ramp meters

[Sensor Types] = 0x1
% 0x1 = Loop detectors
% 0x2 = VRC sensors
% 0x4 = Area sensors

[Sensor Color Code] = 3
% 0 = Count
% 1 = Flow
% 2 = Speed
% 3 = Occupancy

[Vehicles] = 5
% 0 = None
% 1 = Vehicle type
% 2 = Information availability
% 3 = Turning movement
% 4 = Driver behavior group
% 5 = Lane use

[Vehicle Shade Params] = {
    0      # Shade
    86400  # Outstanding time in a segment
    86400  # Outstanding time in the network
}

```

```

[View Markers] = {
  # Label Position Scale Angle Tool ViewType Segment
  # SensorType/Label/Color SignalType Map Legend
  "Map view" 0.5 0.5 0.112069 0 0 0 2 1 0 3 50 1 0
  "I90 / I93 Interchange" 0.332886 0.284409 1.34483 0 0 0 2
1 0 3 50 0 1
  "Incident" 0.400879 0.373999 1.34483 0 1 0 2 1 0 3 50 0 0
  "Sensors" 0.400879 0.373999 5.13012 0 1 0 2 1 2 3 50 0 0
  "Ramp Metring" 0.393233 0.356719 4.2751 5.59596 6 0 2 1 0
3 50 0 0
  "Toll Plaza" 0.948412 0.68546 1.92619 0 0 0 2 1 0 3 50 0 1
  "Ramp Metering 2" 0.347848 0.28101 4.1041 0 1 0 2 1 0 3 50
0 0
  "Ramp Metering 3" 0.263239 0.146937 4.1041 0 1 0 2 1 0 3
50 0 0
}

```

The following is a sample dtaparam.dat file configured for closed loop operation with MITSIM.

```

[Files]

InputDirectory = "./"
OutputDirectory = "./output"
TmpDirectory = "./temp"

// MITSIM is the only
// now
recognized value for
InputFormat = "MITSIM"
// If no path is
// is assumed
// If the character '/'
provided, InputDirectory
// file name,
appears in the
InputDirectory is ignored.

NetworkFile = "simple_reduced1.dat"
HistODFile = "od.dat"
SupplyParamFile = "supplyparamcalc_reduced2.dat"
HistTTFile = "linktime_dynamit2hrs.in"
SocioEcoFile = "socioEco_simple_30guided.dat"
BehParamFile = "BehavioralParameters.dat"
IncidentFile = "incident_dynamit.dat"
//incident_dynamit_new.dat

MitsimOdFile = "od.dat"

MitsimSensorsFile = "Output/sensor.out"

```

```
GuidanceOutputFile = "closedloopguidance.out" //Note that
this will be written into OutputDirectory
```

```
[Simulation]
```

```
StartSimulation = 06:50:00
StopSimulation  = 07:50:00
```

```
OdInterval      = 15          // in minutes
HorizonLength   = 30
```

```
UpdateInterval  = 60          // in seconds
AdvanceInterval = 10          // in seconds
SupplyEpsilon   = 0.01
```

```
[Default]
```

```
OutputCapacity = 0.55          // Default output
                                //capacity per lane
                                // Unit: veh/lane . sec
```

```
FreeFlowSpeed  = 50.0          // Unit: km/hour
```

```
JamDensity     = 0.075         // Unit: vehicles/lane-
                                //group . meter
                                // 0.075 ~= 120
                                //veh/lane-mile
```

```
SpeedDensityAlpha = 1.1
SpeedDensityBeta  = 1.5
```

```
LoaderInputCapacity = 5.0      // Unit: veh/sec
                                // 2200veh/hour
```

```
LoaderOutputCapacity = 5.0    // Unit: veh/sec
                                // 2200 veh/hour
```

```
MaxEstIter = 3
MaxPredIter = 1
```

```
PurposeOfRun = 0                // 0 Realtime:
                                // 1 Planning: BaseCase
                                // 2 Planning: ATIS/VMS
                                //Predictive Scenario
                                // 3 Planning: ATIS/VMS
                                //Instantaneous Scenario
                                // note: this is a very important
                                //parameter
                                // especially if DynaMIT_P is
                                //being used.....
```

```

// For the real time version,
//this parameter
// is automatically set to 0 in
//DynaMIT.cc
// even if a value other than 0
//is provided
// in this file.

FrequencyOfInfoUpdate = 300 // this is the time in seconds
// after which
// vms or other information is
//updated
// important only if

PurposeOfRun = 3
// it is automatically set to -1
// within the code
// if purposeOfRun is not equal
//to 3.

spFactor = 1.2
PathTopoFreewayBias = 0.6
RouteChoiceFreewayBias = 0.8
ImpedanceTableCombinationFactor = 0.7
Perturbations = 40
```

BIBLIOGRAPHY

Antoniou, C. (1997), "Demand Simulation for Dynamic Traffic Assignment", S.M. thesis, Department of Civil and Environmental Engineering, Massachusetts Institute of Technology, Cambridge MA.

Ashok, K. (1996), "Estimation and Prediction of Time-Dependent Origin-Destination Flows", Ph.D. thesis, Department of Civil and Environmental Engineering, Massachusetts Institute of Technology, Cambridge MA.

Ashok, K. and Ben-Akiva, M E. (1993), "Dynamic origin-destination matrix estimation and prediction for real-time traffic management systems", in C. Daganzo (ed.), *Transportation and Traffic Theory*, Elsevier Science Publishing Company, Inc. Proceedings of the 12th ISTTT.

Balakrishna, R. (2002), "Calibration of the Demand Simulator in a Dynamic Traffic Assignment Systems", Master's thesis, Department of Civil and Environmental Engineering, Massachusetts Institute of Technology, Cambridge, MA.

Balakrishna, R., Koutsopoulos, H.N., (2004), "Simulation-Based Evaluation of DynaMIT's Route Guidance and its Impact on Travel Times", In *Proceedings of the 10th World Conference on Transport Research*, July 4-8, Istanbul, Turkey.

Beinhaker, R., (2004), "The Impact Of Intelligent Transportation Systems On Supply Chain Management", Master's thesis, Engineering Systems Division, Massachusetts Institute of Technology, Cambridge, MA.

Ben-Akiva, M., de Palma, A., Kaysi, I., (1991), "Dynamic Network Models and Driver Information Systems", *Transportation Research* 25A(5) 251-266, Elsevier Science Publishing Company, Inc.

Ben-Akiva, M.E., de Palma, A., Kaysi, I., (1996), "The Impact of Predictive Information on Guidance Efficiency: An Analytical Approach." In Bianco, L., Toth, P. (Eds), *Advanced Methods in Transportation Analysis*, Springer-Verlag, Berlin, pp. 413-432.

Ben-Akiva, M.E., Bierlaire, M., Koutsopoulos, H.N. and Mishalani, R., (2002). "Real Time Simulation of Traffic Demand-Supply Interactions within DynaMIT", in M. Gendreau and P. Marcotte (eds), *Transportation and network analysis: current trends. Miscellanea in honor of Michael Florian*, pp. 19-36, Kluwer Academic Publishers, Boston/Dordrecht/London.

Booz-Allen & Hamilton, (1994), Evaluation of Phase II of the *SmarTraveler* Advanced Traveler Information System Operational Test, Submitted to: Central Transportation Planning Staff, Boston Metropolitan Planning Organization.

Chauhan, A., (2003), "Development and Evaluation of Diversion Strategies under Incident Response using Dynamic Traffic Assignment System", S.M. thesis, Department of Civil and Environmental Engineering, Massachusetts Institute of Technology, Cambridge MA.

Downs, A., (1984), *Stuck in Traffic: Coping with Peak-Hour Traffic Congestion*, The Lincoln Institute of Land Policy, The Brookings Institution, Washington, D.C.

Federal Highway Administration, (2000), *A Roadmap for the Research, Development and Deployment of Traffic Estimation and Prediction Systems for Real-Time and Off-Line Applications*, Technical report, FHWA, US-DOT, McLean, Virginia.

Federal Highway Administration, (2001), *Managing Our Congested Streets and Highways*, publication number FHWA-OP-01-018, FHWA, US-DOT, Washington, DC.

Institute for Transportation Studies, University of Leeds, (1999). *SMARTTEST: Simulation Modeling Applied to Road Transport European Scheme Tests, Best Practice Manual*, Available from: <http://www.its.leeds.ac.uk/projects/smartest/deliv8.PDF>.

Intelligent Transportation Systems Program, Massachusetts Institute of Technology. (2003). *Evaluation Report (Part A): Evaluation of Estimation and Prediction Capabilities*, Available from: <http://www.dynamictrafficassignment.org>.

Kaysi, I., (1992), "Frameworks and Models for the Provision of Real-Time Driver Information", Ph.D. thesis, Department of Civil Engineering, Massachusetts Institute of Technology, Cambridge MA.

Levinson, D., (1999), "The Value of Advanced Traveler Information Systems For Route Choice", *Transportation Research Part C*, 11, Elsevier Science Publishing Company

Lo H.K, Szeto W.Y., (2002), "A Methodology for Sustainable Traveler Information Services", *Transportation Research, Part B*, 36, Elsevier Science Publishing Company, Inc.

Mahmassani, H.S., Sbayti H., Victoria I., Zhou X., Chiu Y., (2003). *DYNASMART-P Calibration and Evaluation*, Available from <http://www.dynamictrafficassignment.org>.

Mahmassani, H.S., Hu, T-Y. and Jayakrishnan, R., (1992), "Dynamic Traffic Assignment and Simulation for Advanced Network Informatics (DYNASMART)". In *Proceedings of the 2nd International CAPRI Seminar on Urban Traffic Networks*, Capri, Italy.

Mehta, M., (2001), "Design and Implementation of an Interface for the Integration of DynaMIT with the Traffic Management Center", Master's thesis, Department of Civil and Environmental Engineering, Massachusetts Institute of Technology, Cambridge, MA.

Oh J., Jayakrishnan, R., (2002), "Emergence of Private Advanced Traveler Information Service Providers and Its Effect on Traffic Network Performance", In *81st Annual Meeting of the Transportation Research Board*, Washington, D.C., Jan 13-17, 2002.

Sussman, J.M., (2004), "ITS Then and Now", *Civil Engineering Magazine*, March 2004, American Society of Civil Engineers, Reston, VA.

Toledo, T., (2003), "Integrated Driver Behavior Modeling", Ph.D. thesis, Department of Civil and Environmental Engineering, Massachusetts Institute of Technology, Cambridge MA.

US Department of Transportation, (2003), *National ITS Architecture*, US-DOT, Available from: <http://itsarch.iteris.com/itsarch/index.htm>.

Varian, H., (1999), "Market Structure in the Network Age", In *Understanding the Digital Economy*, May 25-26, 1999 Department of Commerce, Washington, D.C.

Yin Y., Yang H., (2002), "Simultaneous Determination of the Equilibrium Market Penetration and Compliance Rate Of Advanced Traveler Information Systems", In *Transportation Research, Part A*, 37, Elsevier Science Publishing Company, Inc.

Yang, Q., Koutsopoulos H.N., Ben-Akiva M.E., (1999), "A Simulation Laboratory for Evaluating Dynamic Traffic Management Systems". In *Proceedings of the 79th Annual Meeting of The Transportation Research Board*.

Wunderlich, K., Hardy, M., Larkin J., Shah V., (2001), *On-Time Reliability Impacts of Advanced Traveler Information Services (ATIS): Washington DC Case Study*, Mitretek Systems.