

SSGN Conversion to Host ALVIN

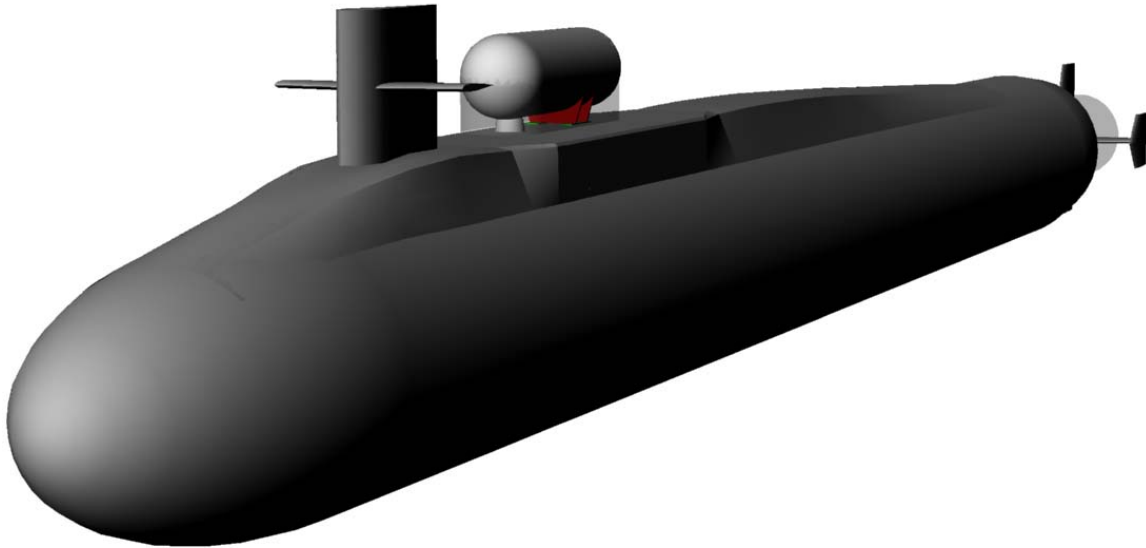

LCDR L. Andrew Gish

LT J. Steven Ramsey

LCDR Michael W. Temme

31 January 2003

Massachusetts Institute of Technology

Cambridge, MA

Page Intentionally Left Blank

Executive Summary

The Submarine Launched Undersea Research Vessel (SLURV) is a concept design for the conversion of an OHIO class (SSGN) Submarine to host a deep-diving submersible, ALVIN. The primary modifications involved are the design and construction of an ALVIN Dry Deck Shelter (ADDS), modification of the SSGN to support the ADDS, and modifications to ALVIN to allow submerged launch and recovery from the ADDS. The proposed ADDS would attach to the SSGN in a manner similar to the current Dry Deck Shelter (DDS) configuration over lock-out chamber (LOC) 1 or 2. ALVIN would be modified slightly by removing its sail to allow it to fit within the hangar of the ADDS. The principal characteristics of the SLURV are summarized below:

Modified SSGN (ADDS & ALVIN installed)	
Length	560 ft
Diameter	42 ft
Displacement	16,600 ltons (surfaced) 18,750 ltons (submerged)
Draft	34.57 ft
BG	1.70 ft (submerged, flooded)
GM _T	1.65 ft (surfaced, dry)
Reserve Buoyancy	14.0%
Propulsion	60,000 hp
Speed Reduction	5% (submerged)
Crew (SSGN)	155
ALVIN Crew	8
ADDS Characteristics	
LOA	46 ft
Length of Hangar	35 ft
Diameter	14 ft (outside diameter)
Weight	58.5 ltons
Displacement	195.0 ltons
Design Depth	Test depth of SSGN
Conversion Cost	
Total (ADDS, ALVIN, SSGN)	\$39.17 M

The design is modular in nature, allowing the ADDS to be loaded only when necessary to conduct ALVIN missions. When installed, the ADDS covers one LOC,

precluding the use of that LOC for other missions. The strike mission of the SSGN would not be affected by the addition of the ADDS. ALVIN can be loaded in the ADDS pier side, and launched and recovered covertly when the SSGN is submerged. The ADDS and ALVIN can be completely removed when not required for missions, and the SSGN returned to its baseline configuration. Graphical renderings of the concept design are shown below.

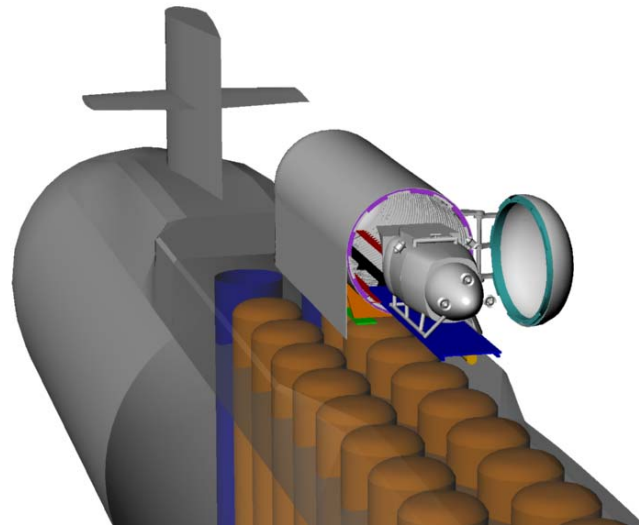
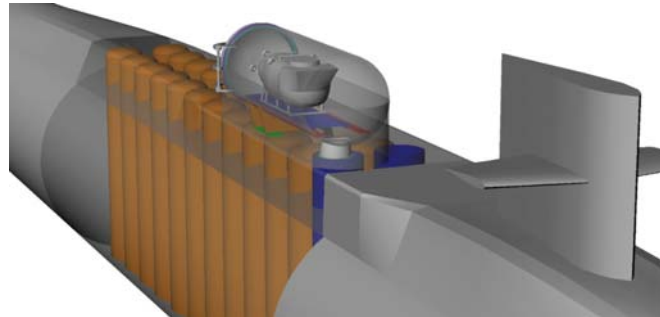

Preliminary structural, stability, and speed analyses were conducted on the SLURV concept design. All analyses showed the design to be feasible. The SLURV concept design is a cost-effective solution to provide a covert undersea research platform.

Table of Contents

EXECUTIVE SUMMARY	3
1.0 MISSION NEED	11
1.1 DEFENSE GUIDANCE AND POLICY	11
1.2 ADVERSARY CAPABILITIES ANALYSIS	11
1.3 CURRENT UNITED STATES CAPABILITY ASSESSMENT	12
1.4 MISSION NEED	13
1.5 RECOMMENDED ALTERNATIVES	13
2.0 DESIGN REQUIREMENTS AND PLAN	15
2.1 REQUIRED OPERATIONAL CAPABILITY	15
2.2 CONCEPT OF OPERATIONS/OPERATIONAL SCENARIOS/PERFORMANCE ASSESSMENT MODELS	15
2.2.1 Scenario 1: Conduct Scientific Research	15
2.2.2 Scenario 2: Locate, Identify and Recover an Object of Interest	16
2.2.3 Performance Assessment Model (PAM)	16
2.3 GOALS, THRESHOLDS, AND CONSTRAINTS	17
2.4 DESIGN PHILOSOPHY	18
2.5 DECISION PROCESS	18
2.5.1 Effect on SSGN Mission	19
2.5.2 Undersea Mission Capability	19
2.5.3 Depth Limit for ALVIN Transfer	20
2.5.4 SSGN Speed Reduction	20
2.5.5 Factor of Operational Effectiveness	20
2.5.6 Difficulty of Modification	21
3.0 CONCEPT EXPLORATION	23
3.1 BASELINE CONCEPT DESIGN	23
3.2 MODIFICATION OPTIONS	23
3.2.1 Option 1: ALVIN attached in manner of ASDS with fairing	23
3.2.2 Option 2: Large DDS to house ALVIN	24
3.2.3 Option 3: ALVIN attached to Missile Compartment Logistics Trunk	25
3.2.5 Option 5: ALVIN recessed in bottom hangar	26

3.2.6 Option 6: ALVIN attached to Engineroom Logistics Trunk with fairing	27
3.3 CONCEPT DESIGN ASSESSMENT	27
3.4 FINAL BASELINE CONCEPT DESIGN	29
4.0 FEASIBILITY STUDY AND ASSESSMENT	33
4.1 DESIGN ANALYSIS	33
4.1.1 Baseline Ship Attributes	33
4.1.2 ALVIN Characteristics and Required Modifications	34
4.1.3 ALVIN Dry Deck Shelter (ADDS)	36
4.1.4 Combat Systems/C4ISR	37
4.1.5 Host Ship Propulsion, Electrical, and Auxiliary Systems	38
4.1.6 Survivability and Signatures	39
4.1.7 Manning	40
4.1.8 SSGN Arrangements	40
4.1.9 ADDS Structural Design	44
4.1.10 ADDS Subsystems Description	47
4.1.11 Weights and Stability	48
4.1.11.1 Baseline Ship Balance	48
4.1.11.2 ADDS Balance	49
4.1.11.3 ALVIN Balance	49
4.1.11.4 Equilibrium Polygon	50
4.1.11.5 Lead Solution	52
4.1.11.6 Surfaced Stability	52
4.1.11.7 Submerged Stability	53
4.2 PERFORMANCE ANALYSIS	54
4.2.1 SSGN Mission Capability	54
4.2.2 SSGN Speed Reduction	56
4.2.3 SSGN Acoustic Signature	56
4.3 OPERATION AND SUPPORT	56
4.4 ROUGH COST ESTIMATE	58
5.0 DESIGN CONCLUSIONS	61
5.1 SUMMARY OF FINAL CONCEPT DESIGN	61
5.2 FINAL CONVERSION DESIGN ASSESSMENT	62
5.3 AREAS FOR FURTHER STUDY	63
ACKNOWLEDGEMENTS	65

REFERENCES.....	67
APPENDICES.....	69
APPENDIX A : MISSION NEED STATEMENT.....	71
APPENDIX B : ALVIN CHARACTERISTICS.....	74
APPENDIX C: FOE AND DF CALCULATIONS.....	86
APPENDIX D: SSGN SUBMARINE MATH MODEL.....	88
APPENDIX E: ADDS STRUCTURAL DESIGN.....	89
APPENDIX F: DRAG FORCE CALCULATIONS.....	90
APPENDIX G: HOLD-DOWN BOLT SHEAR STRESS CALCULATIONS.....	91
APPENDIX H: ADDS WEIGHT AND VOLUME CALCULATIONS.....	92
APPENDIX I: SIMPLIFIED COST MODEL.....	94

LIST OF FIGURES

Figure 1. SSGN Baseline Characteristics	23
Figure 2. FOE vs. DF	29
Figure 3. Forward View of ADDS Mated to Starboard Lockout Chamber.....	30
Figure 4. Aft View of ADDS Mated to Starboard Lockout Chamber	30
Figure 5. ADDS Detail	31
Figure 5. ADDS Detail	31
Figure 6. ASDS and DDS topside arrangement.....	34
Figure 7. General ALVIN Arrangements	35
Figure 8. ADDS Characteristics	37
Figure 9. Topside Arrangement	41
Figure 10. Inboard Profile of Missile Compartment.....	41
Figure 11. Ordnance Magazine – SOF Tube 1 & 2 – 4 th Level	42
Figure 12. ASDS Battery Charging Station.....	43
Figure 13. ASDS Hydraulic Station	43
Figure 14. Cross Section of ADDS Hangar.....	44
Figure 15. ADDS Launch and Recovery System	48
Figure 16. Equilibrium Polygon	50
Figure 17. SSGN with DDS and ADDS	55

LIST OF TABLES

Table 1. SLURV Design Thresholds and Goals	17
Table 2. General Submarine Design Objectives	17
Table 3. SSGN Mission Effect Scoring	19
Table 4. SSGN Speed Reduction Scoring.....	20
Table 5. Design Parameter Weighting Factors	21
Table 6. Individual Design Option FOE and DF	28
Table 7. Overall FOE and DF	28
Table 8. SSGN Principal Ship Characteristics.....	33
Table 9. ALVIN Specifications	35
Table 10. ADDS Principal Dimensions	45
Table 11. Safety Factors	45
Table 12. PSF Summary	46
Table 13. Surfaced Stability.....	52
Table 14. Submerged Stability.....	54
Table 15. Cost Estimating Parameters.....	59
Table 16. Cost of Conversion Project.....	59
Table 17. Submarine Launched Undersea Research Vessel Characteristics	61
Table 18. Comparison of Final Concept Design to Design Objectives	62

Page Intentionally Left Blank

1.0 Mission Need

1.1 Defense Guidance and Policy

The Mission Need Statement (MNS), Appendix A, provides requirements for a deep-sea research vessel for the 21st Century. The MNS complies with the defense guidance and policy set forth in Joint Vision 2020 [1] and Sea Power 21 [2]. The Submarine Launched Undersea Research Vessel (SLURV) meets the requirements of the MNS and specifically addresses the Joint Vision 2020 and Sea Power 21: *Sea Shield* issue of information superiority.

In the rapidly changing and constantly fluctuating international political environment of the 21st century, information superiority will play an increasingly important role in military conflicts. The SLURV will provide national leaders with an innovative means to covertly obtain undersea information. This information could be scientific or military in nature. Military undersea intelligence gathering is essential to the operational concepts of dominant maneuver and full-dimensional protection.

Additionally, the MNS and the subsequent SLURV address “the need to prepare now for an uncertain future” [1]. The SLURV is a transformational system in that it recombines existing technologies, SSGN and ALVIN, in new ways to yield new capabilities. The system could serve as a baseline for future undersea research developments and should influence 21st century Deep Ocean research, design, development, and acquisition program decisions.

1.2 Adversary Capabilities Analysis

The current paradigm in defense planning is to focus on how a potential adversary will fight as opposed to where the conflict will occur or who the adversary will be. Information is the most essential element for successful planning. Asymmetric warfare, reduced protection from geographical distances, and vulnerabilities of foreign governments result in the need for the United States to maintain the ability to gather intelligence in all forms and in all areas of the globe. A key element of intelligence gathering is the ability to conduct undersea research and recover objects from the ocean

floor. The value and utility of undersea research is greatly enhanced if it can be carried out covertly, undetected by the adversary. The SLURV will provide such a capability.

It is unknown whether any other nations or organizations possess a capability for covert undersea research. However, the SLURV is not intended as a direct countermeasure for any specific adversarial system. Therefore, the adversary capabilities are not applicable to the SLURV design.

1.3 Current United States Capability Assessment

The principal deep-sea research submarine of today's Navy is the NR-1. NR-1 is a small nuclear-powered submarine launched in 1969. NR-1 has successfully completed many classified and unclassified missions, including search, object recovery, geological survey, oceanographic research, and installation and maintenance of underwater equipment. NR-1 provides a functional covert undersea research capability. However, the vessel is limited in depth to 3000 ft and must be towed to a research site by a surface ship. Additionally, NR-1 is nearing the end of its design life [3].

Several existing U.S. attack submarines are configured to carry the Deep Submergence Rescue Vehicle (DSRV). The vehicle is capable of limited research operations. Details of these operations are classified.

Other existing undersea research capabilities all require the use of a surface support ship. Several vehicles currently exist that are capable of reaching the deepest parts of the ocean bottom. The SLURV utilizes one of these vehicles, ALVIN.

ALVIN, which is owned and operated by Woods Hole Oceanographic Institution (WHOI), has been in operation since 1964. It was affectionately named after WHOI engineer Allyn Vine, whose influence was pivotal in ALVIN's conception. ALVIN was the first deep-sea submersible capable of carrying passengers, usually a pilot and two observers. After numerous upgrades and reconstruction, ALVIN can plunge to a maximum depth of 14,764 feet. It is equipped with two manipulator arms for handling objects and is capable of maneuvering around rugged bottom areas to perform scientific tasks or take still and video photography [4]. More details on ALVIN are found in Appendix B.

1.4 Mission Need

The roles of a future SLURV will include the following principal areas of naval operations and research:

A. **Oceanographic Sciences.** The SLURV will provide support for research in a variety of fields including Physical Oceanography, Geology/Geophysics, Marine Biology, Atmospheric Science, Ocean Engineering, Chemical Oceanography, Maritime Archeology, and Environmental Science.

B. **Object Manipulation and Recovery.** The SLURV will be able to locate, manipulate, and recover objects of military or scientific interest from the ocean floor.

C. **Underwater Intelligence, Surveillance, and Mapping.** The SLURV will provide a platform to investigate and monitor deep ocean areas covertly and relay essential military information to higher authorities.

Appendix A contains more detailed information regarding the mission need.

1.5 Recommended Alternatives

Potential alternatives for meeting the mission need described above include:

- A. Design of an entirely new class of submarine.
- B. Modification of an Improved LOS ANGELES class submarine to meet the mission requirements.
- C. Modification of an OHIO class (SSGN) submarine to meet the mission requirements.
- D. Modification of a SEAWOLF class submarine to meet the mission requirements.
- E. Modification of a VIRGINIA class submarine to meet the mission requirements.

The OHIO class submarine is the largest of the candidates and provides the greatest available area and volume for modifications. Additionally, the first four OHIO class submarines are currently scheduled for conversion to the new SSGN configuration. The required SLURV modifications could be incorporated into the ongoing SSGN modifications. For these reasons, the OHIO class (SSGN) Design Modification is selected for further investigation.

Page Intentionally Left Blank

2.0 Design Requirements and Plan

2.1 Required Operational Capability

The SLURV must be capable of conducting military and scientific research missions while remaining undetected and without affecting OHIO class SSGN combat missions. These military and scientific research missions include, but are not limited to, the collection of environmental, geological, or biological data; the retrieval of small objects from the ocean floor; and the placement of small instruments or other objects on the ocean floor.

The SLURV modifications must not affect the operating depth capability of the SSGN during normal operations (i.e., not launching or recovering ALVIN). Additionally, the effect on SSGN speed caused by modifications must be minimized. The SLURV must be capable of conducting several undersea missions without surfacing or receiving assistance from other support vessels.

2.2 Concept of Operations/Operational Scenarios/Performance Assessment Models

The concept of operations for the SLURV includes combat missions and a variety of military and scientific research missions. Combat missions (relating to the SSGN) will be largely unaffected by the modifications and will not be discussed here. The research missions of the SLURV are similar to those currently performed by other research submarines such as NR-1. Two potential scenarios for these missions are listed below.

2.2.1 Scenario 1: Conduct Scientific Research

The variety of possible scenarios for scientific research is limitless. For this discussion, a simplified example is used that represents typical scientific operations performed by ALVIN.

The SLURV will transit to the region of interest while remaining undetected. Once on station, ALVIN will be manned and launched from the host ship. ALVIN will then transit to the target area to take samples or make observations at deep depths and on the ocean bottom. Scientific sensors can also be carried by ALVIN to the target area and deployed. Once mission objectives are accomplished, ALVIN will return to the host ship

for recovery. The SLURV will then remain on station for further missions or transit out of the area, still undetected.

2.2.2 Scenario 2: Locate, Identify and Recover an Object of Interest

Recovery of objects by ALVIN is limited by the size and weight of the object. ALVIN is outfitted with two jettisonable, hydraulically powered manipulators with a weight limit of approximately 250 pounds. Objects must fit into the scientific basket for transport to the host ship and are limited in size to approximately 20 cubic feet.

The host ship will receive queuing information from off-board sensors providing coordinates for an object of interest. Based on these coordinates, the SLURV will transit to the region of interest while remaining undetected. Once on station, ALVIN will be manned and launched from the host ship. ALVIN will then transit to the target area and conduct a search for the object using a variety of sensors including side scan sonar and cameras. After the object has been located and identified, ALVIN will use its manipulator arms to place the object into the scientific basket, then return to the host ship. The SLURV will then remain on station for further missions or transit out of the area, still undetected.

2.2.3 Performance Assessment Model (PAM)

A PAM was created to evaluate the effectiveness of various SLURV designs. The following four factors were considered to be the most important aspects of system performance:

- Effect on SSGN combat missions
- Effect on SSGN speed
- Maximum number of ALVIN undersea research missions
- Depth restrictions for ALVIN launch and recovery

By evaluating the above factors for several different ship designs, an optimum design can be selected.

2.3 Goals, Thresholds, and Constraints

A number of goals and constraints were considered in the design of the SLURV. Table 1 below shows the design thresholds and goals for what were considered the four key design parameters of the SLURV.

Table 1. SLURV Design Thresholds and Goals

	Threshold	Goal
SSGN Mission Capability	Affect 2 missions*	No effect
ALVIN Mission Capability	3 ALVIN missions	Unlimited
Depth Limit for Transfer Operations	200 ft	Test depth of SSGN
SSGN Speed Reduction	30%	0%

* Effect on SSGN mission is described in Section 2.5.1

The ship must also meet the general submarine design requirements listed in Table 2, which were derived from the Massachusetts Institute of Technology Professional Summer Class Notes on Submarine Design Trends [5].

Table 2. General Submarine Design Objectives

Requirement	Description
Reserve Buoyancy	12% Minimum
Margin Lead	No less than current amount
BG	No less than 1.0 ft
Acoustic Signature	Equal to baseline SSGN

The MNS (Appendix A) provides the following design constraints:

A. Key Boundary Conditions.

- 1) Architecture - The ship design must employ a total ship architectural/engineering approach that optimizes mission effectiveness and performance while minimizing cost of conversion.
- 2) Design - Consideration should be given to the maximum use of modular designs in the host vessel's infrastructure. Emerging technologies must be accounted for during the developmental phase.

B. Operational Constraints.

- 1) The host vessel must remain fully functional and operational in all environments. Host vessel performance limitations, similar to current limitations associated with hosting the Advanced Seal Delivery System (ASDS) and Dry Deck Shelter (DDS), are considered acceptable.
- 2) The host vessel must provide launching and recovery facilities for ALVIN.
- 3) The host vessel must be able to operate in U.S., foreign, and international waters in full compliance with existing U.S. and international pollution control laws and regulations.
- 4) The host vessel must be able to transit through the Panama Canal (PANAMAX).

2.4 Design Philosophy

The overarching goal of this project is to provide a covert undersea research and object placement or retrieval capability while minimizing the effect on the host platform. A design philosophy was adopted to achieve this goal. The design philosophy consists of several principles:

- A. Maximize the use of existing systems and technology to the greatest extent possible.
- B. Minimize changes to the physical characteristics and operational doctrine of ALVIN.
- C. Maintain the baseline combat capabilities of the host submarine where possible.
- D. Minimize the amount of modification necessary to the systems on the host submarine. This will minimize the cost of the conversion.
- E. Minimize the effect on the host submarine's operational schedule during the conversion process. Accomplish as much work as possible off-hull.
- F. Maximize flexibility of the system by using a high degree of modularity.

2.5 Decision Process

The decision process involves the comparison of possible concept designs to determine which design or combination of designs best meets the mission requirements. A weighted scoring scheme was developed to quantify the four design parameters of

Table 1. These four parameters were then used in an analytic hierarchical process (AHP) to determine a numerical performance index for each concept design.

2.5.1 Effect on SSGN Mission

The first design parameter, SSGN mission capability, was quantified on a discrete scale from 0 to 1. The SSGN combat capabilities were grouped into three categories:

- Dry Deck Shelter (DDS) capability
- Advanced SEAL Delivery System (ASDS) capability
- Tomahawk Land Attack Missile (TLAM) capability

A score of 1 means the SLURV modifications have no effect on the SSGN combat capabilities. A score of 0.666 means 1 of the 3 capabilities is degraded or reduced. This could occur by ALVIN utilizing one of the existing SSGN lockout chambers (LOCs) or obstructing one or more TLAM tubes. A score of 0.333 means 2 of the 3 capabilities is degraded or reduced. A score of 0 means all 3 capabilities are degraded or reduced.

Table 3 summarizes the mission effect scoring.

Table 3. SSGN Mission Effect Scoring

Mission Effect	Score
No Effect	1.00
Affect 1 Combat Capability	0.666
Affect 2 Combat Capabilities	0.333
Affect 3 Combat Capabilities	0.00

2.5.2 Undersea Mission Capability

The second design parameter, undersea mission capability, was quantified as either 0 or 1. A score of 1 means that all systems on ALVIN can be recharged or replenished between missions while the SLURV is submerged, yielding virtually unlimited mission capability. To accomplish this level of performance, the design must permit access to the exterior of ALVIN in a dry enclosure to allow refilling of oil tanks and recharging HP air. A score of 0 means that one or more system on ALVIN cannot be replenished while submerged. Therefore, the number of missions is limited.

2.5.3 Depth Limit for ALVIN Transfer

The third design parameter, depth limit for ALVIN transfer operations, was also quantified as either 0 or 1. A score of 1 means that transfer and recharging operations can be completed down to SSGN test depth. A score of 0 means the transfer and recharging operations are limited to some depth shallower than test depth, but still submerged.

2.5.4 SSGN Speed Reduction

The fourth design parameter, SSGN speed reduction, was quantified as 0, 0.5, or 1.0. A score of 1.0 means the SLURV modifications have no effect on SSGN speed. This is only possible if the modifications fit entirely within the envelope of the original SSGN. A score of 0.5 means that the modifications will cause a speed reduction of up to 15% of the base SSGN speed. A score of 0 means that the modifications will cause a reduction between 15% and 30% of the base SSGN speed. The speed reduction for the various alternative designs was estimated using empirical data from similar previous designs, such as a DDS mounted on a LOS ANGELES class submarine. The speed reduction scoring is summarized in Table 4 below.

Table 4. SSGN Speed Reduction Scoring

Reduction, as % of SSGN Base Speed	Score
0%	1.0
1%-15%	0.5
16%-30%	0

2.5.5 Factor of Operational Effectiveness

Once the individual design parameters were quantified, they were combined in a weighted AHP scheme to yield a single Factor of Operational Effectiveness (FOE). The final effectiveness index was a number between 0 and 1, with 1 being best and 0 being worst. The four design parameters were prioritized and weighted based on overall importance to the SLURV mission. The weighting factors are shown in Table 5.

Table 5. Design Parameter Weighting Factors

Design Parameter	Factor
SSGN Mission Effect	0.3
Undersea Mission Capability	0.3
Depth Limit for ALVIN Transfers	0.2
SSGN Speed Reduction	0.2

2.5.6 Difficulty of Modification

In addition to performance, the difficulty of making the proposed modifications for each alternative design was assessed. Difficulty of modification could then be qualitatively related to the “cost” of the modification. Rather than attempting to quantify the actual monetary cost of each design, a Difficulty Factor (DF) scale was used. The DF was broken into two subcategories: modifications to the SSGN, and modifications to ALVIN or fabrication of other off-hull structures. Each subcategory was quantified on a scale of 1 to 3, with 1 being the simplest modification and 3 being the most complex or time-consuming modification. The subcategories were then weighted based on overall contribution to difficulty of the SLURV modification. The SSGN modifications were weighted more heavily (0.7) than the off-hull modifications (0.3). This is because the SSGN modifications will require removing the ship from service for some period of time, and will have a significant effect on naval operational capabilities. The modifications to ALVIN or other off-hull structures have a lesser effect because they can be carried out in smaller facilities and do not require taking a national asset out of service.

The FOE of each concept design was plotted versus its DF of the modifications. This plot was then used to determine the ‘best’ design(s) for further development. The details of the concept designs investigated for this study and the subsequent results are described in Chapter 3.

Page Intentionally Left Blank

3.0 Concept Exploration

3.1 Baseline Concept Design

The current design of the OHIO class SSGN serves as the baseline for the SLURV concept design. The baseline characteristics of the SSGN are summarized in Figure 1.

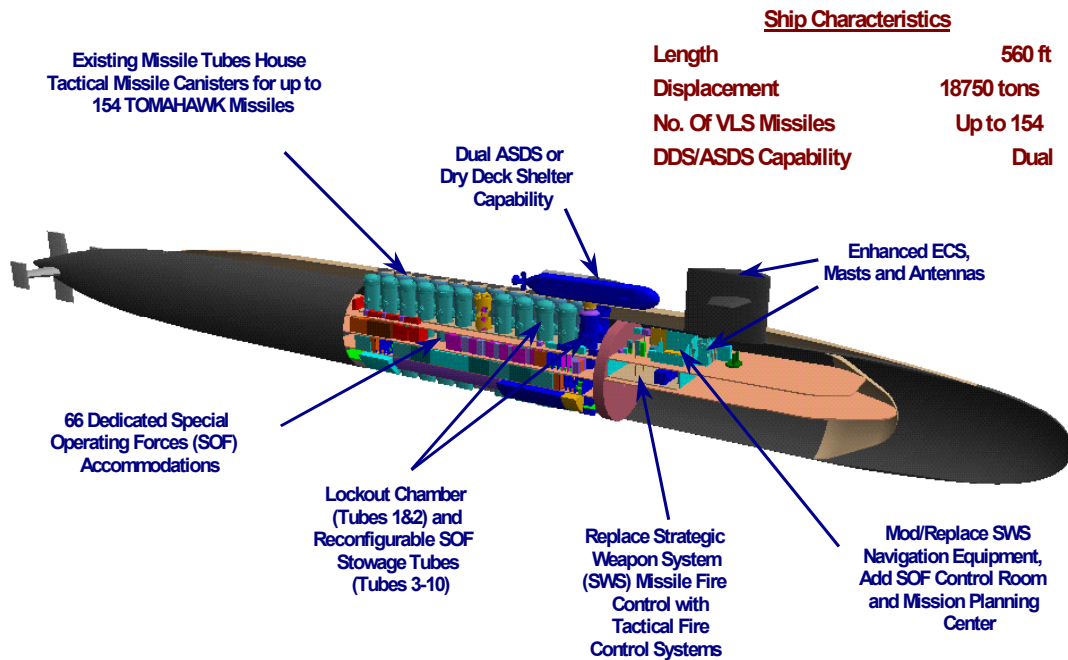

Figure 1. SSGN Baseline Characteristics [6]

3.2 Modification Options

Based on the given operational requirements, a total of six design options were investigated to allow the SSGN to host ALVIN. The designs were then subjected to the FOE-DF evaluation scheme described in Chapter 2 to determine the optimum selection. The six concept design options are described below.

3.2.1 Option 1: ALVIN attached in manner of ASDS with fairing

This design involves attaching ALVIN to the SSGN using a transfer trunk and hold down arrangement similar to the method proposed for the ASDS. ALVIN would mate with the transfer trunk and attach to the SSGN superstructure. Personnel and

equipment would be passed to/from ALVIN through the associated lockout chamber on missile tube 1 or 2. A fairing would be added to the SSGN in front of missile tube 1 or 2, which would redirect some flow around ALVIN, thus reducing the hydrodynamic forces on ALVIN. Some minor modifications to ALVIN would be required which would include adding a fairing to mate with the associated LOC on the SSGN. More significant modifications include adding a bottom hatch to ALVIN and adding hold-down equipment to allow ALVIN to attach to the SSGN superstructure.

Benefits of this design include very little modification to the host SSGN, which would in turn mean a lower cost for the conversion. By attaching ALVIN in a manner similar to ASDS, there would be very little effect on current mission capability of the SSGN. Problems with this design include a limitation on number of missions for ALVIN due to the inability to refill or recharge all support systems. The SSGN would also be limited in speed based on the hydrodynamic limits on ALVIN and its associated structure.

3.2.2 Option 2: Large DDS to house ALVIN

This option involves housing ALVIN in a large DDS structure on the superstructure of the SSGN. This ALVIN Dry Deck Shelter (ADDS) would mate to the existing LOC on either missile tube 1 or 2. The ADDS would be approximately 14ft in diameter and 40ft in length. It would sit on either the port or starboard side of the superstructure and is not anticipated to interfere with the other LOC. The structure of the ADDS would be very similar to a DDS, with the exception that the ADDS would not contain a hyperbaric chamber. For initial concept exploration, the ADDS was considered pressure-tight to a depth of 200ft. All ALVIN transfer and charging operations would occur shallower than 200ft, when the ADDS is dry. Below 200ft, the ADDS would be flooded and ALVIN would be inaccessible. *[For later designs, the ADDS depth limits were increased to coincide with the test depth of the SSGN]*

Because the ADDS would use the same mating surfaces and hold-down connections as the DDS, very little modification to the SSGN would be necessary. Some auxiliary systems, such as hydraulics and high-pressure (HP) air, may need to be rerouted to provide service to the ADDS. However, no major structural modifications would be

needed. The only significant modification to ALVIN would be removing the sail. The major modifications required for this design would be the design and construction of the ADDS. However, because of its similarity to a DDS, this should be relatively simple.

Benefits of this system include very minor modifications to the SSGN and complete modularity with existing systems. The drawbacks include an SSGN speed reduction, due to the increased drag on the ADDS and possible strength considerations for the ADDS foundations, and the depth limitation on ALVIN transfer operations.

3.2.3 Option 3: ALVIN attached to Missile Compartment Logistics Trunk

This design would substitute a transfer trunk and hold down arrangement in place of the Missile Compartment Logistics Trunk. ALVIN would then attach to this module in a manner similar to the method proposed for the ASDS. When attached, ALVIN would sit below the superstructure. The Towed Buoyant Antennas (TBAs) would be removed and the associated hydraulics would be used to shut a large “clamshell” over ALVIN to reduce hydrodynamic drag.

Benefits of this method include no reduction in SSGN mission capability and very little reduction in maximum SSGN speed. The main drawback of this design is a limitation on ALVIN endurance due to the inability to refill/recharge all support systems.

Difficulty of modification associated with the SSGN would be due to removal of the TBAs and creation of a large hydraulic “clamshell”. The difficulty of modification associated with ALVIN would be due to fabrication of the transfer trunk that would sit inside the pressure hull in place of the logistics trunk.

3.2.4 Option 4: ALVIN housed inside Missile Tube (vertically)

This option involves housing ALVIN vertically in one of the SSGN missile tubes that can currently support Special Operations Forces (SOF) canisters (missile tubes 3-10). A retractable launch and recovery skid would be used to raise and lower ALVIN for launch and recovery. Significant modifications to ALVIN would be required to allow it to fit within the current missile tube diameter. The SSGN would also require modification of the missile tube to allow flooding and draining of the tube and

installation of the lift and skid mechanism. Personnel and equipment transfer to ALVIN would be through a hatch in the side of the missile tube.

The merits of this design include very little effect on the current capability of the SSGN. Since ALVIN is completely housed in the missile, there is no reduction in SSGN speed and very little reduction in SSGN mission capability. Additionally, since the missile tube is normally dry, all support services can be provided to ALVIN allowing performance of multiple missions. Problems include the massive modifications to ALVIN to allow it to fit inside the missile tube. ALVIN would have to be reduced in diameter by roughly four feet, which would make the interior of the vessel too small for its current manning. Housing ALVIN vertically would also pose problems for personnel entry and support service connections.

3.2.5 Option 5: ALVIN recessed in bottom hangar

This option involves carrying ALVIN in an enclosed hangar bay in the bottom of the missile compartment. The hangar would be placed in the bottom of missile tubes 2, 4, and 6. The hangar bay would extend from the ship centerline to the port side of the pressure hull. The hangar would be 33ft long and 11.5ft high, and would fit entirely below the lowest platform in the missile tubes. This area is currently void space, so no other capabilities would be affected. The hangar would be a free-flood area, with large doors that open hydraulically to allow ALVIN to move in or out. A pressure-tight deck would be installed above the hangar, with a hatch that would mate directly to the top hatch of ALVIN. The deck and hatch would become part of the submarine pressure hull. These modifications would also require cutting ten circular frames, which would have a significant structural effect on the ship.

The port side location of the hangar was chosen to minimize interference with the sanitary tanks located on the starboard side. The port side location would also require moving Auxiliary Tank 4 approximately 20ft aft. The fourth level of missile tube 2 would be converted from an ordnance magazine to a lockout chamber to allow access into the hangar bay.

This design would require moderate modifications to ALVIN. The sail would be removed, but the top access hatch would be retained. Additionally, the battery and air

charging connections would have to be moved to allow access through the transfer trunk. Most significantly, this option would require a change in the operational doctrine of ALVIN to allow the vehicle to operate and dock below a host ship.

The major benefit of this design is that the hangar bay is totally enclosed. Therefore, the speed and acoustic signature of the SSGN are unaffected. The major drawback is that the hangar bay is never dry, even on the surface. Therefore, ALVIN maintenance and replenishment of some operating fluids is impossible. This would limit the mission capability of ALVIN.

3.2.6 Option 6: ALVIN attached to Engineroom Logistics Trunk with fairing

This option would substitute a transfer trunk and hold down arrangement in place of the Engineroom Logistics Trunk. ALVIN would then attach to this module in a manner similar to the method proposed for the ASDS. When attached, ALVIN would sit below the superstructure. A fairing would be placed over ALVIN to reduce hydrodynamic drag.

Benefits of this method include no reduction in SSGN mission capability. The main drawbacks of this concept are a limitation on ALVIN endurance due to the inability to refill or recharge all support systems and a reduction in maximum SSGN speed.

Difficulty of modification associated with the SSGN would be due to removal of sections of the superstructure and fabrication of a fairing. The difficulty of modification associated with ALVIN would be due to fabrication of the transfer trunk that would sit inside the pressure hull in place of the logistics trunk.

3.3 Concept Design Assessment

After each design option was defined, the scoring system described in Section 2.5, “Decision Process”, was applied to each one. Table 6 below shows the individual values for Factor of Operational Effectiveness (FOE) and Difficulty Factor (DF) used to determine an overall FOE and DF, respectively.

Table 6. Individual Design Option FOE and DF

	Concept design					
FOE	1	2	3	4	5	6
Depth Restriction	1	0	1	1	1	1
ALVIN Endurance	0	1	0	1	0	0
Speed Limit	0	0.5	0.5	1	1	0.5
SSGN Mission Effect	0.666	0.666	1	0.666	1	1
DF						
SSGN Modification	1	1	2.5	2	3	2
ALVIN Modification	2	2	2	3	2	2

The scoring in Table 6 resulted in the overall FOE and DF shown in Table 7.

Table 7. Overall FOE and DF

Concept design	FOE	DF
1 - ALVIN attached in manner of ASDS with fairing	0.4	1.3
2 - ALVIN inside large DDS	0.6	1.3
3 - ALVIN attached to MCLET with clamshell doors	0.6	2.35
4 - ALVIN inside missile tube (vertically)	0.9	2.3
5 - Bottom recessed hangar in SSGN	0.7	2.7
6 - ALVIN attached to ERLET with fairing	0.7	2

Once the overall FOE and DF was determined for each option, the values were plotted on a FOE vs. DF graph to determine the Pareto Frontier containing the non-dominated design option(s). The results are shown in Figure 2 and Appendix C.

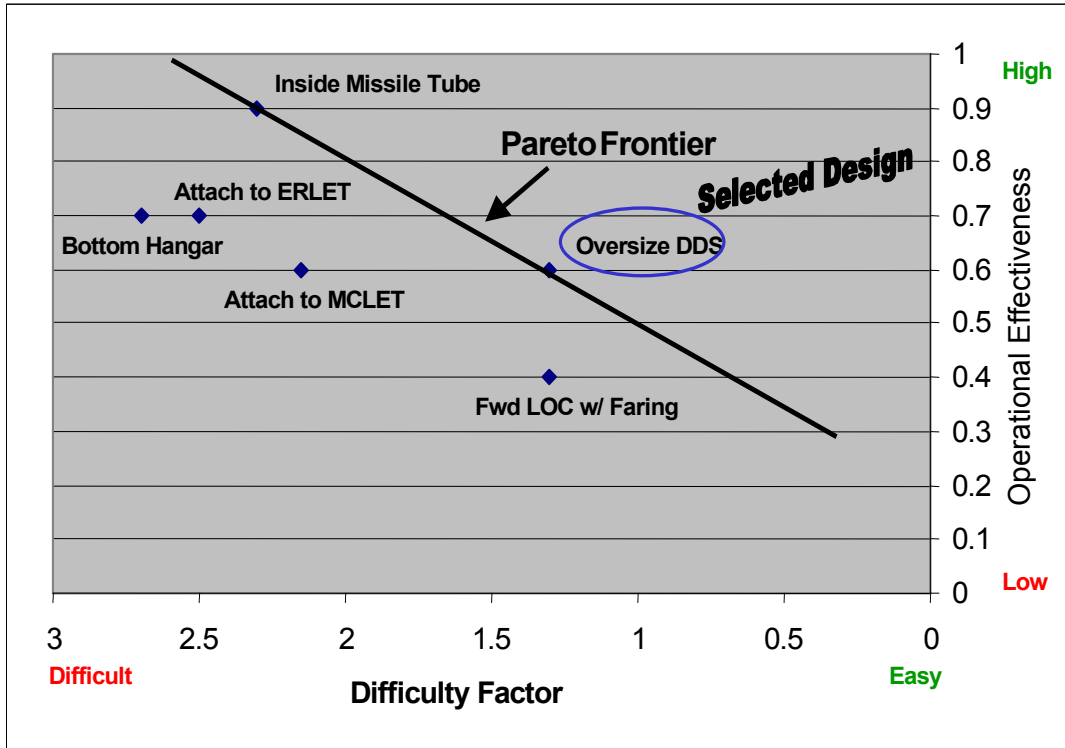

Figure 2. FOE vs. DF

3.4 Final Baseline Concept Design

Due to its combination of relatively high FOE and low DF, Option 2 (oversize DDS to house ALVIN) was chosen as the baseline concept design. While the option to house ALVIN vertically inside a missile tube was on the Pareto Frontier, it was determined that the reduction in size required to fit ALVIN into the missile tube would make it too small for its current missions. The ADDS option required minimal modifications to both ALVIN and SSGN, and the modular nature of the design allowed complete return of the SSGN to its full mission capability upon removal of the ADDS hangar. Figures 3, 4, and 5 show concept design sketches.

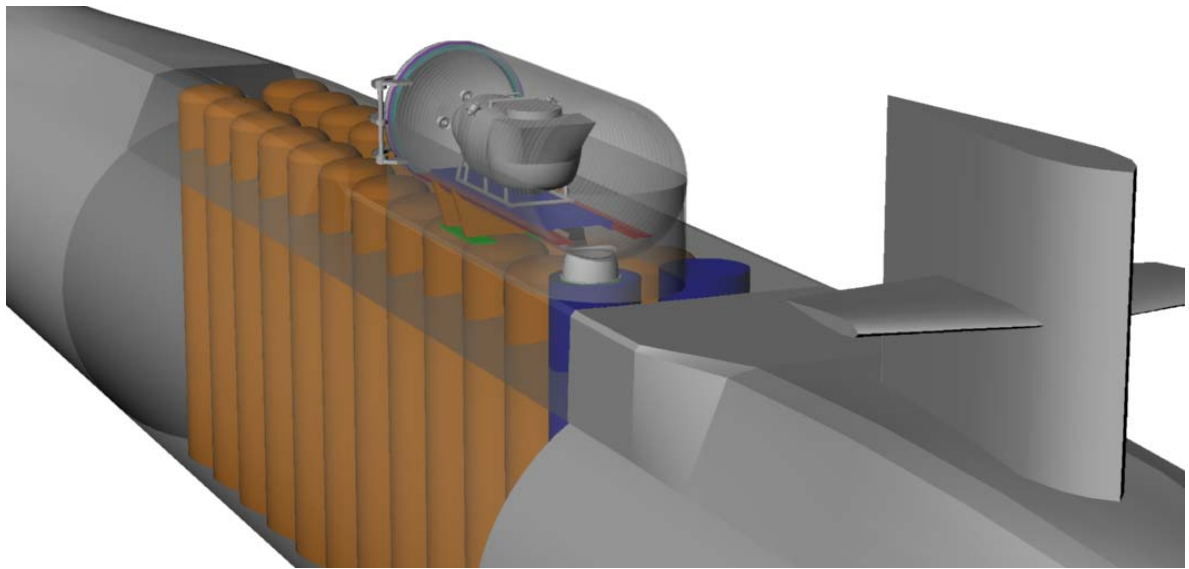

Figure 3. Forward View of ADDS Mated to Starboard Lockout Chamber

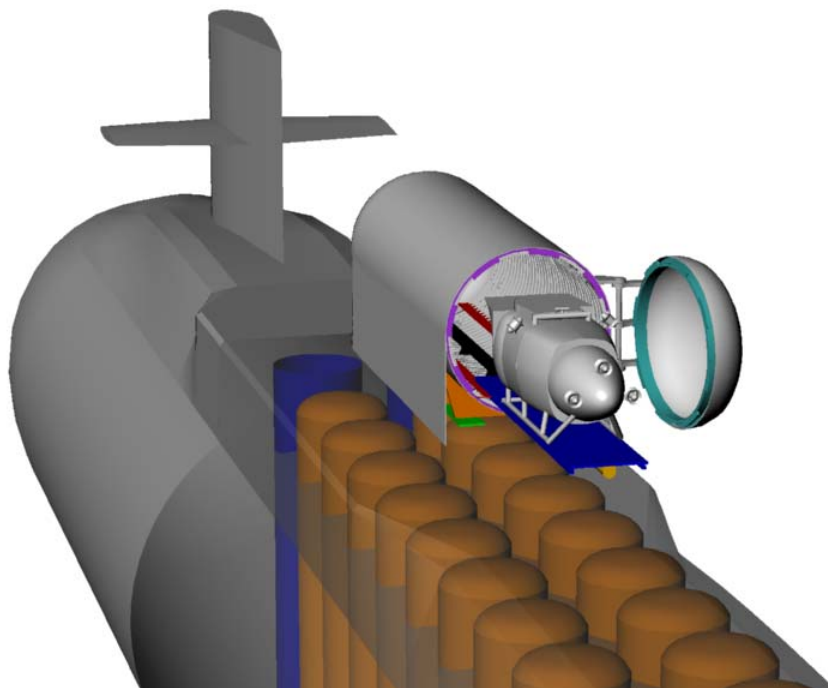

Figure 4. Aft View of ADDS Mated to Starboard Lockout Chamber

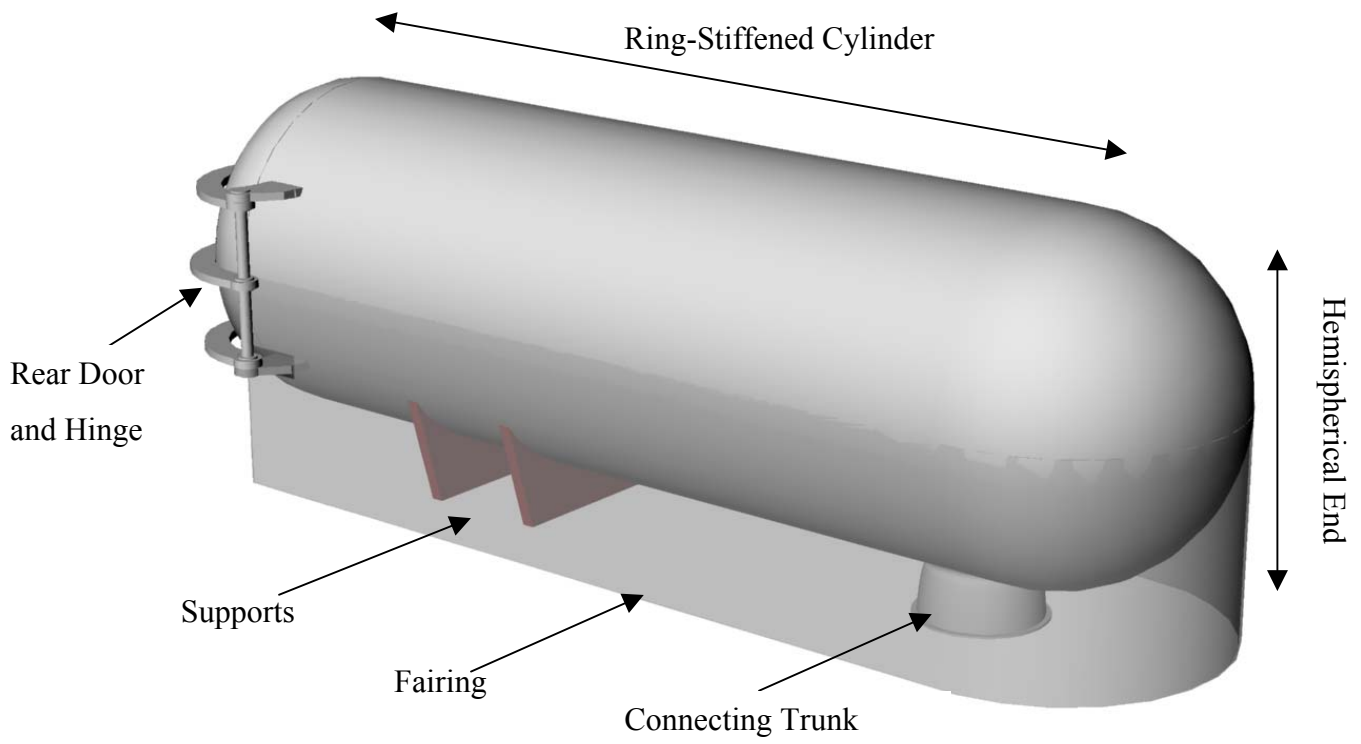

Figure 5. ADDS Detail

Page Intentionally Left Blank

4.0 Feasibility Study and Assessment

4.1 Design Analysis

The Final Baseline Concept Design was analyzed to evaluate its feasibility. The principal tool used for this analysis was the Massachusetts Institute of Technology XIII-A Submarine Math Model [7]. The standard SSN model was modified to approximately represent an SSGN. The SSGN model is included as Appendix D.

4.1.1 Baseline Ship Attributes

The OHIO class SSGN serves as the starting point for the Final Baseline Concept Design. The SSGN is a modified strategic missile submarine (SSBN) that has been converted to allow it to launch TLAMs; handle ASDS and DDS; and deploy Special Operations Forces (SOF). SSGN basic ship characteristics are listed in Table 8.

Table 8. SSGN Principal Ship Characteristics [8]

Displacement	16,600 ltons (surfaced) 18,750 ltons (submerged)
Length	560 ft
Diameter	42 ft
Draft	36.4 ft
Propulsion	Nuclear, 2 Main Engines, 1 Shaft 60,000 hp
Speed	>20 kts (submerged)
Crew	155
Embarked SOF capability	66
Number of VLS Missiles	Up to 154
DDS/ASDS Capability	Dual

The SSGN is configured with two LOCs in missile tubes 1 and 2. These LOCs are designed to allow SOF to exit the submarine while submerged and also allow for the transfer of personnel to and from an ASDS or DDS, attached to the back of the ship. The topside arrangement of the ASDS and DDS is shown in Figure 6.

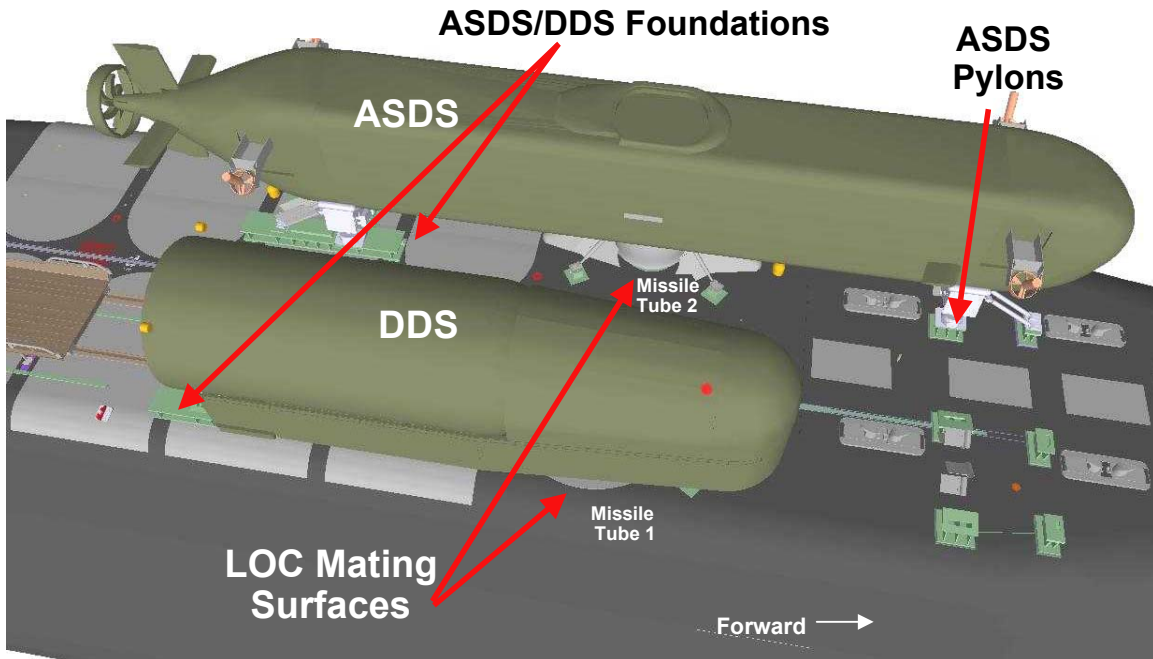

Figure 6. ASDS and DDS topside arrangement

To allow the SSGN to launch and recover ALVIN, the ALVIN Dry Deck Shelter (ADDs) was designed to be large enough to completely house ALVIN and be attached in a manner similar to the current DDS.

4.1.2 ALVIN Characteristics and Required Modifications

ALVIN is a deep-sea manned submersible built by the Applied Science Division of Litton Industries in 1964 with funds from the Office of Naval Research. The vehicle consists of a titanium pressure hull, batteries (and associated electronic systems), ballasting system, thrusters, manipulators, and sensors, all connected within a tubular frame. Portions of this frame are enclosed within a fairing to reduce hydrodynamic drag. A small sail is attached at the top of the vehicle to prevent taking water down the top pressure hull hatch when on the surface. ALVIN's overall specifications are summarized in Table 9.

Table 9. ALVIN Specifications [9]

<p>Length: 7.1 m (23.3 ft.)</p> <p>Beam: 2.6 m (8.5 ft.)</p> <p>Operating Depth: 4,500 m (14,764 ft)</p> <p>Normal Dive Duration: 6-10 hours</p> <p>Speeds: Cruising - 0.8 km/hr (0.5 knot) Full - 3.4 km/hr (2 knots)</p>	<p>Height: 3.7 m (12.0 ft)</p> <p>Draft: 2.3 m (7.5 ft) surfaced</p> <p>Gross Weight: 17 metric tons (35,200 lbs)</p> <p>Payload: 680 kg (1,500 lbs)</p> <p>Complement: Pilot - 1 Scientific Observers – 2</p>
<p>Pressure Hull: 208 cm (82 in) outer diameter, 4.9 cm (1.9 in) thick titanium</p> <p>Hatch Opening: 48.2 cm (19 in) max. diameter for science equipment</p> <p>Total Power: 46.8 kWh maximum (120V x 390 Ah), 35 kWh usable (120V x 292 Ah)</p> <p>Max. Cruising Range: 5 km (3 miles) submerged @ 14 meters/minute</p> <p>Life Support Duration: 216 man-hours (72 hrs x 3 persons)</p>	

Figure 7 below provides a diagram showing the layout and subsystem arrangement for ALVIN.

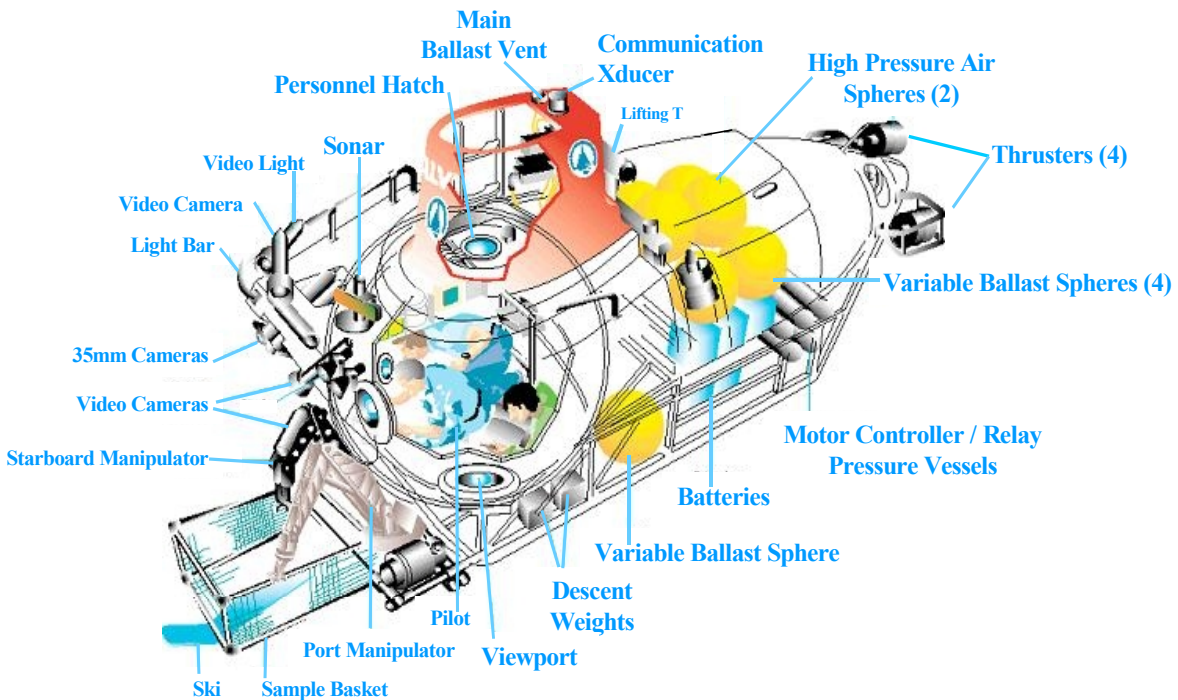

Figure 7. General ALVIN Arrangements [9]

ALVIN's mission capabilities are listed below [9]:

- Carrying one or two observers and various internal and/or external instrumentation and tools.
- Maneuvering within areas of rugged bottom topography.
- Hovering at neutral buoyancy in mid-water and/or resting on the bottom to perform scientific and engineering tasks, including still and video photography.
- Using its manipulators and storage basket to deploy various scientific tools and to collect samples.
- Providing a limited amount of electric and hydraulic power plus data logging capabilities for instruments and equipment not normally part of the submersible.

To limit the size of the ADDS, ALVIN will have to be modified by replacing the permanent sail with a temporary inflatable one. The sail is only used to add freeboard on the surface and prevent water from entering the hatch, so an inflatable sail would satisfy the same requirements. Additionally, the method of battery cell removal will be changed. The current method of vertical removal will be altered to a horizontal method where the cells are removed from the rear of the vessel. ALVIN would also require rotating clamps at its base to attach itself to the movable sled of the ADDS (see sections 4.1.5 and 4.1.10). Finally, a fiber optic data link and inertial navigation system would be added to increase accuracy and covertness of communication and positioning.

4.1.3 ALVIN Dry Deck Shelter (ADDS)

Due to the support service requirements for ALVIN, the ADDS was designed to completely enclose ALVIN. In the initial analysis of alternatives, it was assumed that the shelter would be flooded at depths greater than 200 feet. After further review, it was determined that the shelter needed to remain dry to the test depth of the SSGN.

The final design for the ADDS was a ring-stiffened cylinder 14 feet in diameter with a hemispherical forward end and an oblate hemisphere for the rear door. The total length of the assembly is approximately 46 feet with the rear door shut. A cylindrical trunk approximately four feet in diameter extends downward from the front end of the ADDS to the SSGN superstructure. This trunk provides the physical connection between

the SSGN and the ADDS in addition to being a means of personnel transfer. A fairing to reduce hydrodynamic drag surrounds the entire assembly.

Unlike operations with the DDS, ALVIN should be deployable and retrievable from the ADDS with no diver support. To this end, automatic and remotely controlled hydraulic systems are envisioned for the ADDS. When deploying ALVIN, the outer door of the ADDS will be unlocked and opened by an operator onboard the SSGN. A moveable “sled” to which ALVIN is fastened will then slide rearward out of the ADDS. An operator within ALVIN will then direct unfastening of the vehicle from the sled to conduct the operation. Retrieving ALVIN will simply be the reverse of deploying. Figure 8 below shows the dimensions and general arrangement of the ADDS.

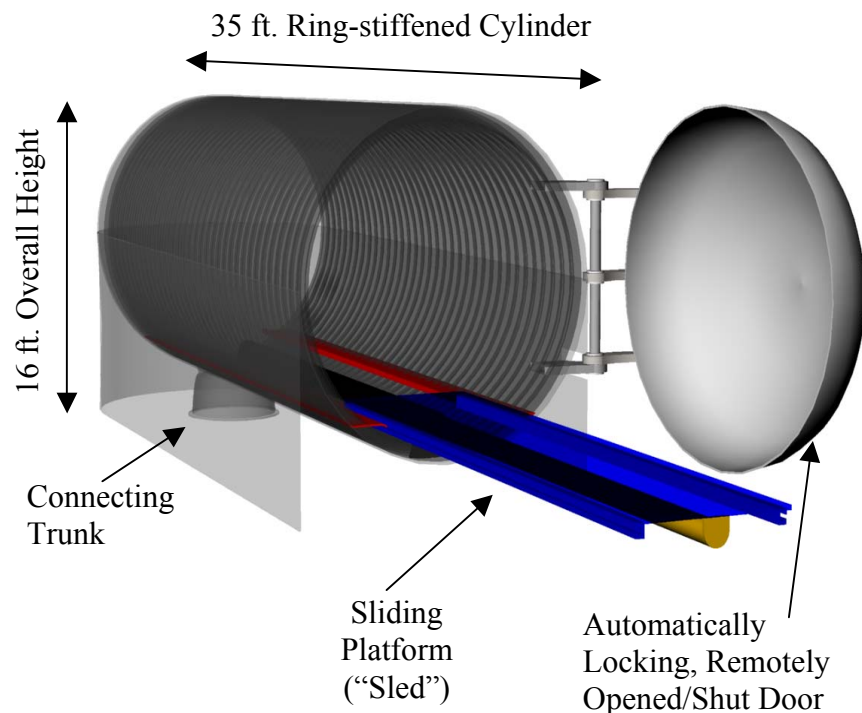

Figure 8. ADDS Characteristics

4.1.4 Combat Systems/C4ISR

The modified SSGN will retain all combat systems and C4ISR systems of the baseline SSGN. When the ADDS is installed, the SSGN will be limited to one ASDS or DDS in addition to the ADDS. Due to the modular nature of the ADDS, the hangar can be easily removed while in port, restoring the original configuration of the SSGN.

4.1.5 Host Ship Propulsion, Electrical, and Auxiliary Systems

In order for ALVIN to be able to perform multiple missions, the host ship must be able to supply it with the following services:

- I. A battery charger capable of providing voltage and current of 145V and 45A, respectively, in addition to stowage space for spare 12V cells
- II. A high pressure air connection to recharge ALVIN's ballasting system
- III. An oxygen connection for recharging oxygen bottles *or* stowage space for spare oxygen bottles
- IV. Stowage space for sofnalime and lithium hydroxide canisters (used for carbon dioxide absorption aboard ALVIN)
- V. Stowage space for various hydraulic and compensating oils
- VI. A navigational input to fix ALVIN's position at time of deployment.

In addition, the SSGN must provide the following services to the ADDS:

- VII. Hydraulic power to operate the rear door locking ring, door ram, drain valves, and sled ram.
- VIII. Electrical power for limit switches associated with door and sled operations in addition to overhead lighting.
- IX. A drain connection and vent path to drain the ADDS.

The SSGN will address these requirements in the following ways:

- I. The government-furnished battery charger installed to recharge batteries on the ASDS should suffice to recharge batteries on ALVIN [15]. The hull penetrations and associated wiring would remain unchanged.
- II. A 3,000 psig diver air connection for DDS operations already exists [16].
- III.-V. Existing SOF stowage could be used to store oxygen bottles, spare 12V cells, lithium hydroxide canisters, and various oils.
- VI. Navigational information is input to ALVIN via a laptop computer through an ethernet connection inside ALVIN's pressure hull. Additionally, a rendezvous sonar transponder placed at the top rear of the SSGN sail for ASDS operations [15] will assist in ALVIN's return to the SSGN at the completion of a mission.
- VII. Hydraulic power is supplied from the SSGN's external hydraulic system in the vicinity of tubes five and six for use by the ASDS Pylon Hydraulic Control System [15].
- VIII. Electrical connections in the vicinity of the LOCs are capable of providing 115V, 25A, three-phase electrical power [16].
- IX. The ADDS will drain through the LOC upper hatch cavity drain in the same way that the ASDS mating trunk is drained. A standpipe within the ADDS will connect to the LOC upper hatch air line to provide a vent path to the SSGN atmosphere [15].

4.1.6 Survivability and Signatures

The SLURV utilizes the same hull structure as the OHIO class SSGN, with the exception of the ADDS. No internal structural modifications were done to the host ship.

The SLURV is therefore expected to have the same level of survivability as the OHIO class SSGN. More detailed analysis would be necessary to verify survivability.

The addition of the ADDS and the performance of scientific and military research missions will affect the stealth of the SSGN in transit and on station. The surface area and structure of the ADDS will lead to uneven flow around the shelter and will affect the acoustic signature of the SSGN. The acoustic signature effect is not expected to be greater than the dual DDS operations planned for the baseline SSGN. Additional noise sources are anticipated from the operation of the hangar door and the launch and recovery sled. Further analysis would be required to determine the severity of these generated noises and their effects on the ship's mission.

4.1.7 Manning

The scientific and military missions of ALVIN require a three-person crew, normally comprised of one pilot and two observers. An Expedition Leader remains with the host ship to provide overall mission supervision. Since normal dive duration is between six and ten hours, a second three-person crew and Expedition Leader would be required to perform repeated missions. Total additional manning for conducting multiple ALVIN missions would therefore be 8 personnel.

It is anticipated that an SSGN conducting ALVIN missions would not require a full complement of 66 SOF personnel. As a result, berthing spaces would be available for the additional ALVIN support. Maintenance and support service for ALVIN will be conducted by the SSGN ship's force Electronics Technicians (ETs), Electricians Mates (EMs), and Machinists Mates (MMs).

Additional personnel are required to load and remove ALVIN pier side (riggers, crane operator, truck driver, etc.), but these personnel were not considered as manning for the purposes of this report.

4.1.8 SSGN Arrangements

Modifications to the SSGN were concentrated in the missile compartment area. No significant structural modifications were required to the baseline SSGN. Major components of the SLURV modification include the installation of the ADDS, oxygen

bottle and oil stowage, battery charging connections, hydraulic connections, and support services for the ADDS.

The ADDS is attached to the SSGN using foundations on the superstructure (similar to the DDS/ASDS foundations) and LOC mating surfaces on missile tubes 1 or 2. Figure 9 shows the topside arrangement with the ADDS attached to the LOC of missile tube 1. The hangar door is open and sled extended to show interference paths. Figure 10 shows the inboard profile of the missile compartment with the ADDS attached to the LOC.

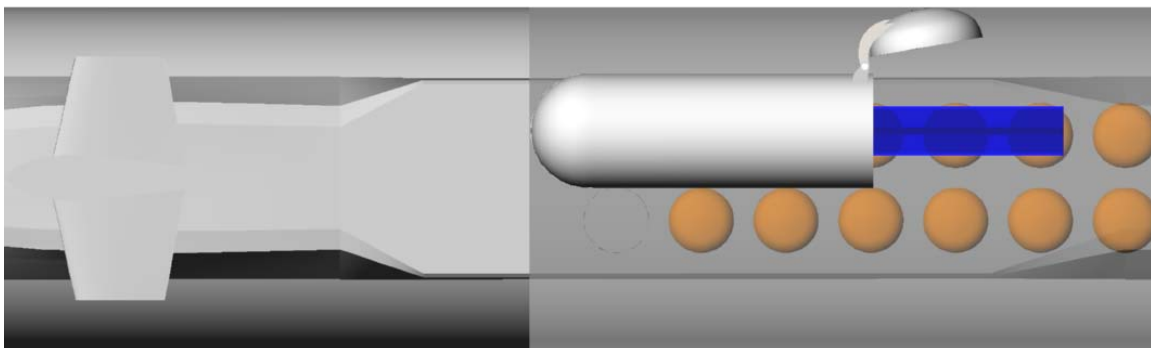

Figure 9. Topside Arrangement

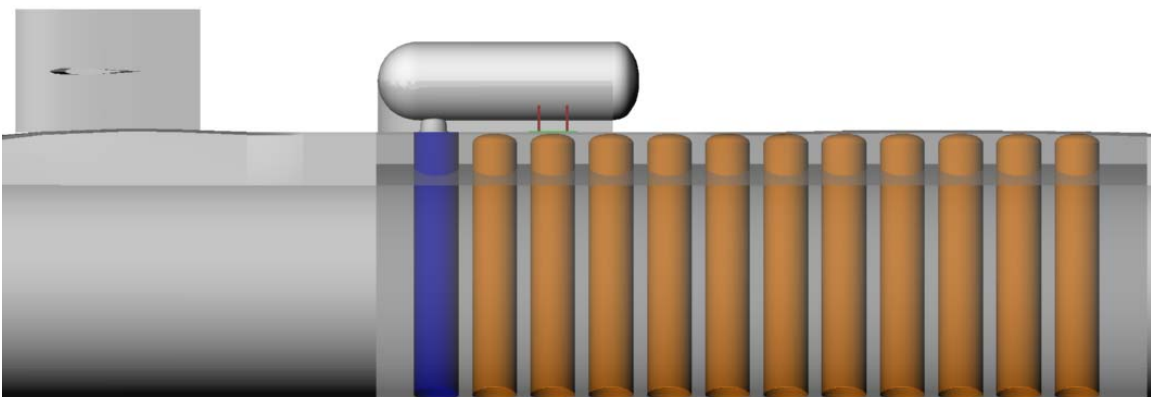

Figure 10. Inboard Profile of Missile Compartment

To allow multiple missions to be conducted by ALVIN, several of its auxiliary systems require recharging or refilling. One of these systems is the oxygen supply on ALVIN. For atmosphere control, ALVIN carries three scuba-sized bottles filled with oxygen. During a normal dive, one oxygen bottle is depleted. To eliminate the hazard

and Quality Assurance (QA) issues of charging oxygen, additional oxygen tanks will be loaded to support multiple missions. The oxygen bottles, 21 of them, will be stored in the ordnance magazine on the 4th level of SOF tube 1 or 2. Oxygen bottles will be mounted on specially designed racks to prevent movement and minimize shock. These racks will be attached to the tie-down rails shown in Figure 11.

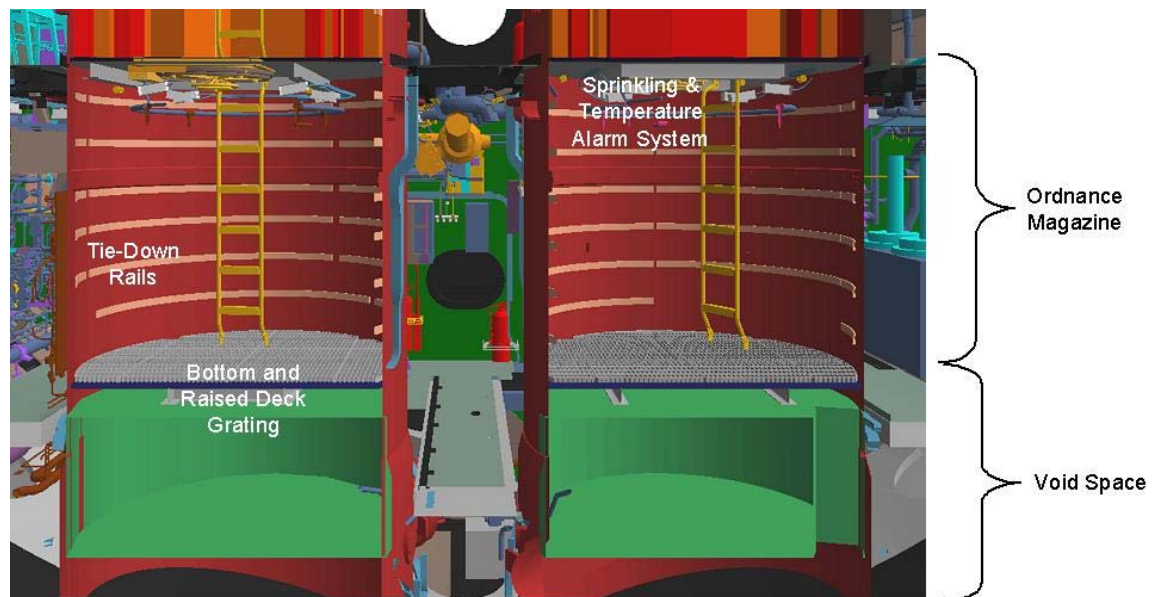

Figure 11. Ordnance Magazine – SOF Tube 1 & 2 – 4th Level [10]

Sofnalime canisters are also required for atmosphere control on ALVIN. Replacement canisters will be stored in the SOF storage area, located on the Missile Compartment 2nd level. Five-gallon oil containers, 10 of them, will also be stored in the SOF storage area.

Battery charging will be conducted using the ASDS battery chargers in Auxiliary Machinery Room Number One (AMR1). The battery chargers convert 440V three-phase 60Hz AC power to 150V-350V DC power. The chargers are connected via cables to connections in the LOC cavity. Cables from the ADDS will plug into these connections when the ADDS is installed, and will terminate at charging connections inside the ADDS hangar. Temporary jumper cables will then connect the ALVIN batteries to the charging connections during battery charging operations. Figure 12 shows the charging station arrangement inside AMR1.

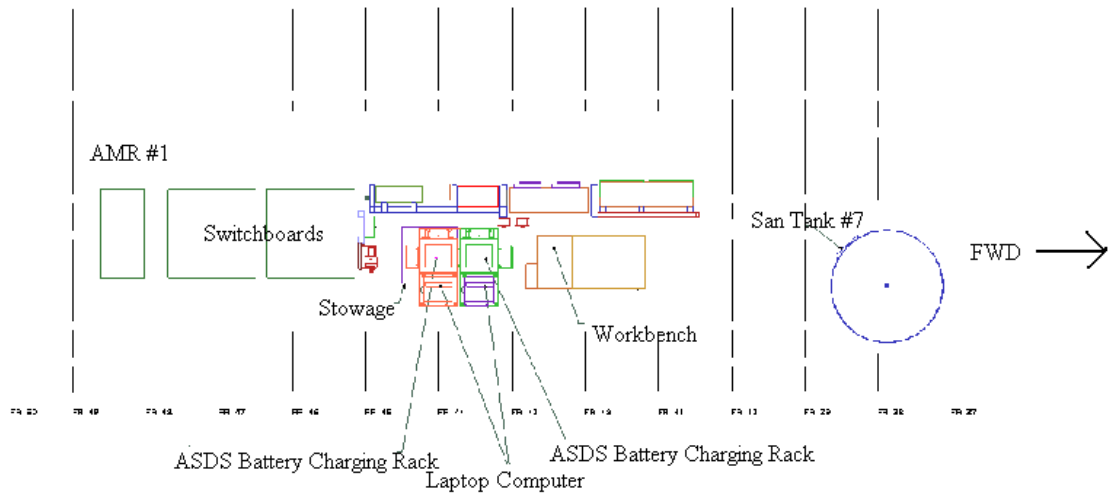

Figure 12. ASDS Battery Charging Station

The baseline SSGN contains a modified external hydraulic system to provide hydraulic power to the ASDS latching mechanisms [15]. An ASDS hydraulic control station is located on the missile compartment upper level, port side. Figure 13 shows this location in the baseline SSGN.

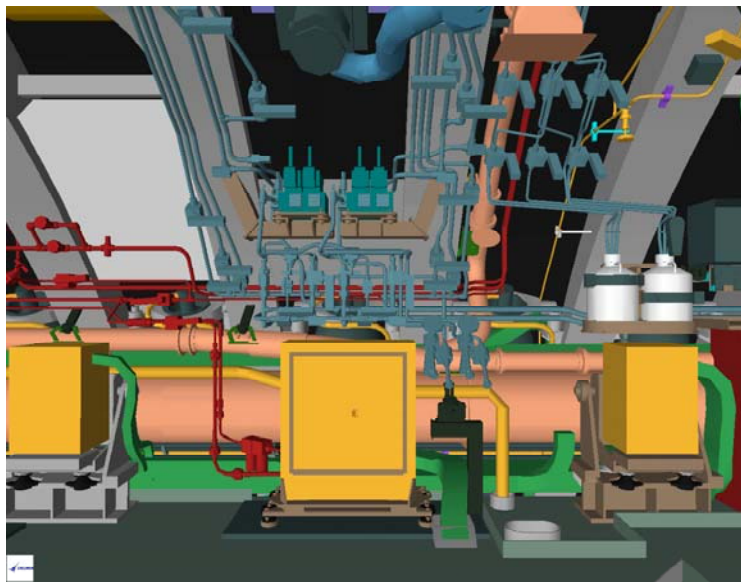

Figure 13. ASDS Hydraulic Station [10]

Piping connections run from the control station, through the superstructure, to the DDS/ASDS tie-down connections topside. The ADDS hydraulic piping will be

connected to the existing topside fittings when the ADDS is installed. Further analysis is required to determine if the existing external hydraulic system is adequate for the large ADDS hydraulic loads. An additional accumulator and fluid reservoir could be added to the ASDS hydraulic station if necessary.

4.1.9 ADDS Structural Design

The ADDS hangar was designed to allow ALVIN (with its sail removed) to completely fit inside the hangar. The current DDS design was used as a starting point for this structural model. It was determined that a hyperbaric chamber would not be required for the ADDS because divers would not be used to launch or recover ALVIN. The shelter was therefore sized to allow personnel access when the hangar is dry to conduct required ALVIN maintenance. The hangar portion of the ADDS is a cylinder 14 ft in diameter and 35 ft long with a hemispherical forward end, and a hinged oblate hemispherical door on the aft end. Figure 14 shows the details of the hangar.

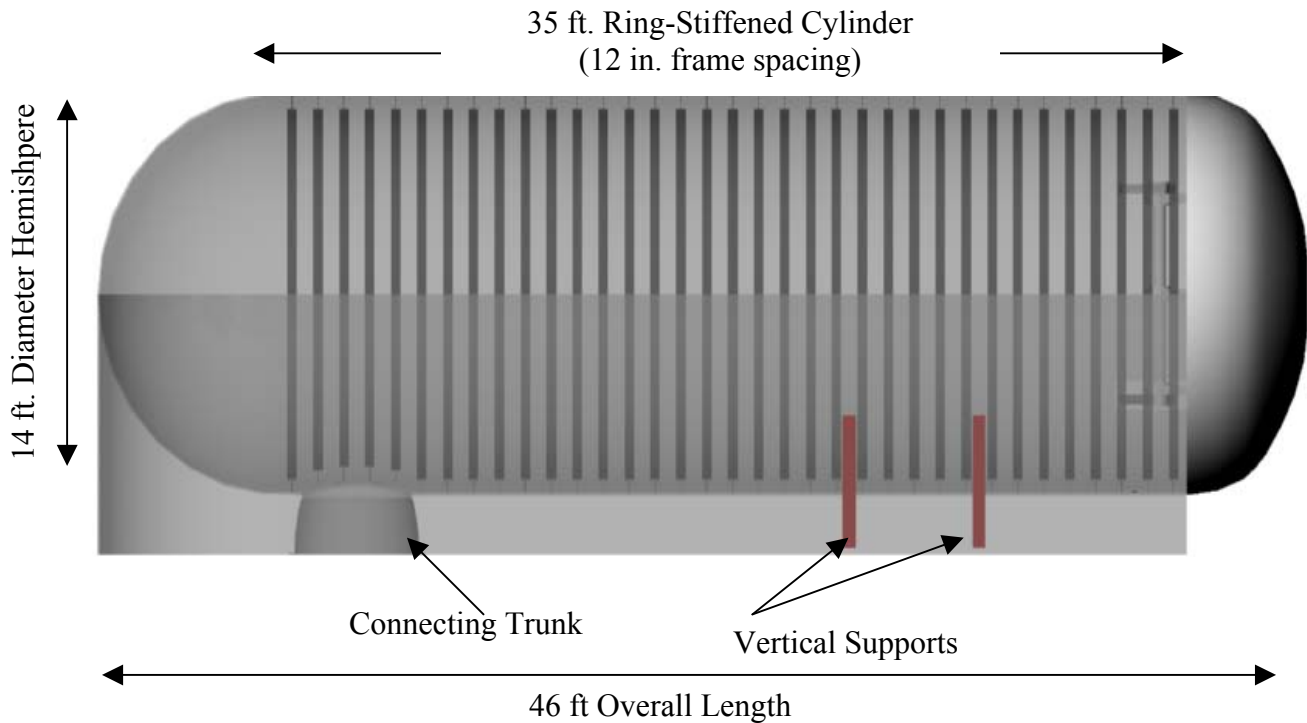

Figure 14. Cross Section of ADDS Hangar

To determine the appropriate size for the shell plating and stiffeners, the hangar was analyzed using the MIT Professional Summer Submarine Structural Design Model

[11]. This model uses shell theory to calculate five hull limit states, or failure modes, for the hangar based upon the assumptions that the hangar bay was a right circular cylinder with a ring-stiffened shell. Using an iterative process, an appropriate shell thickness was determined to be 1.0 inches. Internal 5.5 inch-deep ring frames were used at 12 inch spacing. Table 10 shows the principal dimensions for the shell and stiffeners.

Table 10. ADDS Principal Dimensions

Shell		Stiffeners	
material	HY-80	material	HY-80
diameter	14.0 ft	flange thickness	0.75 in
thickness	1.0 in	flange width	4.4 in
length	35 ft	web thickness	0.4 in
frame spacing	12 in	web height	5.5 in

In accordance with Reference 12, a minimum structural design safety factor of 1.5 was used. For some failure modes though, higher safety factors were used based on the generally accepted uncertainty in the calculations for those specific modes. Table 11 lists the safety factors used in the hangar design.

Table 11. Safety Factors

Failure Mode	Safety Factor
Shell Yield	1.5
Lobar Buckling	2.25
General Instability	3.75
Frame Yield	1.5
Frame Instability	1.8

Using the appropriate safety factor, a pressure load based on the test depth of the SSGN was determined for each failure mode. A failure pressure was then determined using the appropriate calculations for each failure mode. By taking a ratio of the pressure load to the failure pressure, a partial safety factor (PSF) was developed which indicates how much of the safety factor was used in the design. A PSF less than 1.0 indicates that the design will not fail in the specific mode. Using the scantlings from Table 10, PSFs were determined for the ADDS hangar design. Details of the structural calculations are found in Appendix E. A summary is provided in Table 12.

Table 12. PSF Summary

Failure Mode	PSF	Value
Shell Yield	γ_{SY}	0.535
Lobar Buckling	γ_{LB}	0.176
General Instability	γ_{GI}	0.714
Frame Yield	γ_{FY}	0.999
Frame Instability	γ_{FI}	0.484

The shell and stiffener design is therefore considered adequate, based on all PSFs being less than 1.0. The hemispherical ends on the shelter were designed to be 1.0 in thick. Due to the inherent strength of a sphere, the calculations for failure stress of the ends determined the PSF to be 0.35, indicating an adequate design.

Another major structural concern was the required strength of the tie-down connections linking the ADDS to the SSGN. The ADDS is held in place by the transfer trunk and two tie-down cradles which are bolted to the submarine. The major source of stress on these connections will be hydrodynamic drag. The drag force on the ADDS was calculated using hydrodynamic theory. The ADDS was assumed to be a bullet shape with a length-to-diameter (L/D) ratio of 3. Because the L/D ratio is relatively small, pressure (or form) drag has a much greater effect than skin friction drag [13]. A drag coefficient of 0.2 was used. Calculations were done for a maximum speed of 30 knots. The total drag on the ADDS was calculated to be 117,900 lbs. A similar analysis for a conventional DDS yields a total drag force of 52,800 lbs. Thus, the drag force on the ADDS is 2.23 times that of the DDS. The details of the drag calculations are shown in Appendix F.

Next, the hold-down bolt shear stresses were calculated. The conventional DDS transfer trunk is attached to the SSGN with 32 1.7 inch diameter K-Monel bolts. The two pedestal foot pads are each connected with 6 2.25 inch diameter K-Monel bolts [16]. It was assumed that the existing connections would be used for ADDS if they proved adequate. Appendix G shows the details of the shear stress calculations. The ADDS drag force creates an average bolt shear stress of 945 psi. The yield stress of K-Monel is 160 ksi, yielding a factor of safety of 169. Thus, the existing hold-down bolt connections will be adequate for the ADDS connection.

4.1.10 ADDS Subsystems Description

The ADDS is designed so that all ALVIN transfer operations can be completed by operators either inside ALVIN or inside the submarine. Unlike the conventional DDS, no diver support will be needed to launch or recover ALVIN from the ADDS. The hangar door on the ADDS will be opened and closed via a hydraulic mechanism and locking ring. The door swings open approximately 105° to allow access to and from the hangar.

The hangar will contain a hydraulically operated rail-sled system to allow launching and recovery of ALVIN. Longitudinal rails will be installed on the inside of the hangar cylinder. The rails will be mounted to the cylinder shell using expansion joints to allow for longitudinal shell compression without causing rail bowing. The rails will run the entire length of the cylinder and contribute to the longitudinal stiffness of the ADDS. A sled consisting of a platform connected to moving rails will slide along the fixed rails in the hangar. The platform and moving rails will be attached using sliding expansion joints to allow radial compression of the hangar. A hydraulic ram located in the bottom of the hangar and attached to the sled will be used to extend or retract the sled. The total length of the sled mechanism is approximately 30 ft. The sled will protrude 24 ft from the aft end of the hangar when fully extended. The remaining 6 ft of contact between the sled rails and the fixed rails will provide adequate cantilever strength to support the weight of ALVIN. The sled will also contain padeyes to allow the rotating clamps on ALVIN to attach the vehicle to the sled after landing. A system of manual tie-downs will be used to secure ALVIN inside the ADDS once the door is shut and the hangar is drained. Figure 15 illustrates the ADDS launch and recovery system.

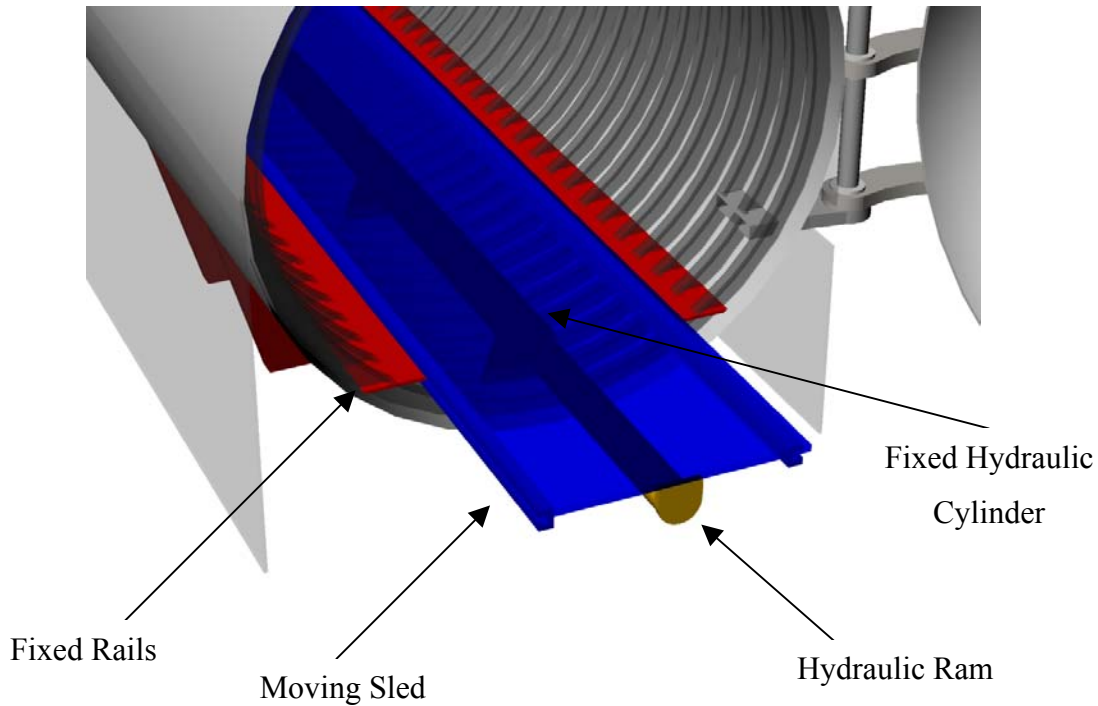

Figure 15. ADDS Launch and Recovery System

The launch and recovery system sled will also contain a fiber optic voice communications link. This link will be automatically engaged when ALVIN clamps itself to the sled upon landing. This link will provide reliable and secure communications between the ALVIN crew and the control station onboard the SSGN during launch and recovery operations.

The ADDS hangar door and sled system will be operated from a control station on the SSGN missile compartment first level. This control station will be adjacent to the LOC Diving Supervisor Station. The control station will contain fiber optic voice and underwater telephone (UWT) communications as well as video monitors from cameras inside and outside of the ADDS.

4.1.11 Weights and Stability

4.1.11.1 Baseline Ship Balance

The baseline SSGN balance was demonstrated using the SSGN Math Model (Appendix D). Data for the model was taken from a “Weight and Ballasting”

presentation, SSGN Program Review, December 9, 2002 [14]. The accuracy of the model was validated by comparing the model results (displacement, speed, draft, etc.) to actual SSBN performance and predicted SSGN performance.

4.1.11.2 ADDS Balance

The weight of the ADDS was calculated using the volume of all structural components described in Section 4.1.9. The volume was multiplied by the density of steel to yield a structural weight. An additional weight was calculated and added to account for the fairing, handling equipment, hinges, etc. This weight was estimated as 15% of the structural weight. The total weight of the ADDS was calculated as 58.518 lton. The longitudinal center of gravity (LCG) was assumed to be at the longitudinal center of the ADDS. The vertical center of gravity (VCG) was assumed to be 4 ft above the base of the ADDS. The VCG is low (i.e., below center) because of the handling system and hydraulic ram located in the bottom of the hangar.

The buoyancy of the ADDS was computed using the envelope volume of the cylinder and hemispherical ends. The total buoyancy of the ADDS was calculated as 194.988 lton.

The weight of water contained in the ADDS was also computed. This weight was found to be 188.3 lton. All calculations are shown in Appendix H.

The net buoyancy of the ADDS when totally submerged and dry is 136.5 lton. When submerged and flooded, the ADDS has a net weight of 51.83 lton. This difference of 188.3 lton must be compensated by the variable ballast system of the SSGN.

4.1.11.3 ALVIN Balance

This conversion involves modifying ALVIN to fit inside the ADDS (see Section 4.1.2). However, for purposes of the weight analysis, the existing ALVIN configuration was used. The current ALVIN has a weight of 16.6 lton, not including variable ballast, and buoyancy of 16.98 lton. ALVIN's ballast system allows it to attain neutral buoyancy. It was assumed that the ballast system will be emptied when inside the ADDS. Therefore, ALVIN has a net buoyancy of 0.38 lton in a flooded ADDS and a net weight of 16.6 lton in a dry ADDS.

4.1.11.4 Equilibrium Polygon

The SSGN Math Model produced an equilibrium polygon for the baseline SSGN. The SSBN variable ballast system was expanded in the SSGN to allow compensation for a wider range of operating conditions. Specifically, the forward missile compensating tank (MCT) was converted into two new tanks, Aux 2A and Aux 2B. The aft MCT was combined with Aux 5. This additional variable ballast capacity accommodates the weight and moment difference between SSGN Strike and SOF missions [14]. The equilibrium polygon shown in Figure 16 illustrates the expanded variable ballast capacity.

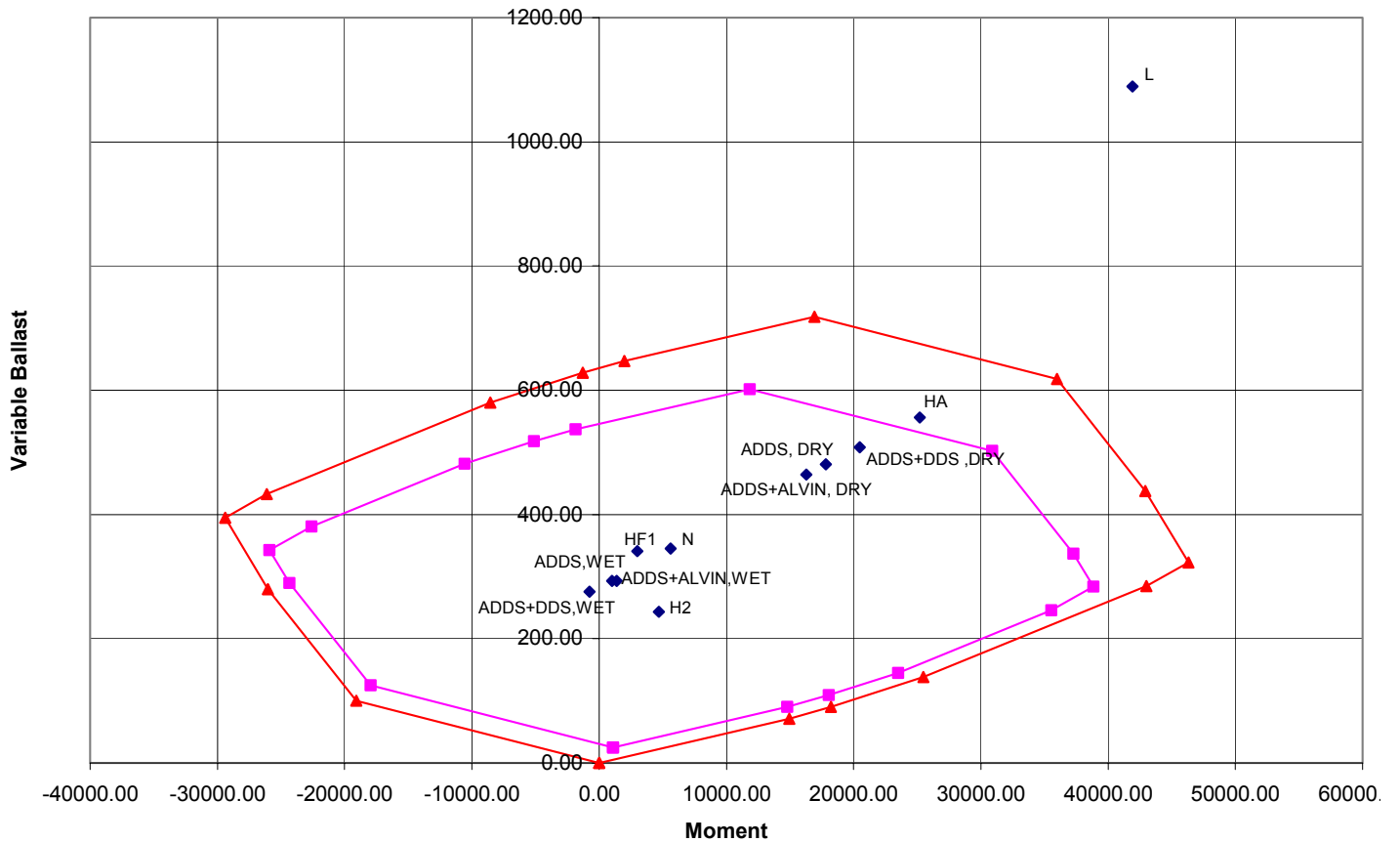

Figure 16. Equilibrium Polygon

Reservations are taken in several variable ballast tanks to account for operational requirements, such as draining a DDS or compensating for TLAM launches. These reservations result in the more restrictive polygon shown in Figure 16.

The baseline SSGN equilibrium was analyzed for five different loading conditions:

- Light (L)
- Heavy aft (HA)
- Heavy forward (HF1)
- Heavy Overall (H2)
- Normal (N)

as defined by the governing ship's documentation. Additionally, the equilibrium of four different ADDS conditions was analyzed:

- ADDS empty, dry
- ADDS empty, flooded
- ADDS with ALVIN, dry
- ADDS with ALVIN, flooded

Finally, the equilibrium of the ship with both the ADDS and a conventional DDS was analyzed, both dry and flooded. All loading conditions involving the ADDS were assumed to be added to the normal SSGN condition.

Figure 16 shows that the light loading condition (L) falls outside the equilibrium polygon. This is because the light condition assumes all missile tubes are empty and dry. The SSGN is not designed to operate in this condition; after missiles are launched, the empty tubes fill with water. The heavy aft condition (HA) falls inside the full capacity polygon, but outside the restricted polygon. This indicates that the HA condition limits the operational capacity of the SSGN. All ADDS conditions fall within the inner equilibrium polygon. This indicates that the existing SSGN variable ballast system is capable of compensating for all possible ADDS conditions while also allowing full SSGN operational capability. Therefore, the SSGN variable ballast system is adequate for SLURV operations.

It must be noted that the baseline SSGN will actually have several different equilibrium polygons, one for each possible mission configuration. This is necessary because of the vast differences in weights for the mission packages. For example, the current estimates for a single missile tube canister vary as much as 6 lton between a SOF mission and a TLAM strike mission. This results in total weight differences of several hundred tons between missions. The final solution to this problem has not yet been

decided, but it may very well require cargo ballast to be added for certain missions [14]. Because of these uncertainties in final SSGN baseline configuration, a more detailed analysis of SLURV equilibrium is impossible.

4.1.11.5 Lead Solution

The SSGN Math Model uses the lead solution given in [14]. Stability lead is placed in the bottom of the missile tubes, and margin lead is placed in the forward main ballast tanks (MBTs). The equilibrium polygon (Figure 16) illustrates that all six conditions of the ADDS fall inside the equilibrium polygon, meaning they can be compensated using the variable ballast system. Therefore, no changes in lead placement are needed to accommodate the ADDS.

4.1.11.6 Surfaced Stability

SLURV surfaced stability was analyzed for the following six cases:

- Baseline SSGN
- ADDS empty, dry
- ADDS with ALVIN onboard, dry
- ADDS empty, flooded
- ADDS with ALVIN onboard, flooded
- ADDS and DDS, both flooded

It was assumed that, under normal operating conditions, the ADDS is dry when surfaced. The conditions with the ADDS flooded are casualty conditions that would result from the submarine emergency surfacing. The stability analysis was done using the SSGN Math Model. Table 13 summarizes the results of the surfaced stability analysis.

Table 13. Surfaced Stability

Condition	Draft (ft)	Trim by Stern (ft)	BM_T (ft)	GM_T (ft)	KG (ft)
Baseline SSGN	34.57	2.86	1.94	1.82	19.860
ADDS Dry	34.57	2.87	1.94	1.68	19.994
ADDS+ALVIN Dry	34.57	2.86	1.94	1.65	20.024
ADDS Wet	34.57	2.86	1.94	1.14	20.532
ADDS+ALVIN Wet	34.57	2.87	1.94	1.15	20.531
ADDS+DDS Wet	34.50	1.19*	1.97	0.93	20.716

**Trim effect caused by relative locations of LCGs of DDS and ADDS*

The addition of the ADDS, with or without ALVIN, does not noticeably affect the draft or trim of the SSGN. This is because the additional weight is small compared to the total weight of the ship, and the longitudinal centers of gravity (LCGs) of the ADDS and ALVIN are directly above the longitudinal center of flotation (LCF) of the ship. The LCG of the DDS is about 10 ft forward of the LCF. Therefore, adding the flooded DDS alters the trim of the ship significantly. Adding the ADDS slightly increases the center of gravity (KG), due to the increased weight on the top of the submarine. This results in a slight decrease in transverse metacentric height (GM_T). However, the metacentric height is greater than the required minimum of 1 ft for all cases. Therefore, the analysis indicates that SLURV surfaced stability is adequate for all normal operating (i.e., dry) cases.

The casualty conditions with the ADDS flooded on the surface result in significant decreases in GM_T . This is because of the large weight of water that is not supported by a buoyant force. The case of both ADDS and DDS flooded on the surface results in a GM_T less than 1 ft. This condition could be prevented by prohibiting the flooding of both structures at once. Furthermore, this condition would be temporary, in that the ADDS and DDS could be drained as soon as the submarine reaches the surface.

4.1.11.7 Submerged Stability

Submerged stability of the SLURV was analyzed for the following seven cases:

- Baseline SSGN
- ADDS empty, dry
- ADDS with ALVIN, dry
- ADDS empty, flooded
- ADDS with ALVIN, flooded
- ADDS and DDS, both dry
- ADDS and DDS, both flooded

In order for a submerged submarine to be stable, the center of gravity must lie below the center of buoyancy. This ensures a positive righting moment for all roll angles. The center of gravity (KG) and distance between center of gravity and center of buoyancy

(BG) were computed for each case using the SSGN Math Model. The results are summarized in Table 14.

Table 14. Submerged Stability

Condition	KG (ft)	BG (ft)
Baseline SSGN	19.860	1.82
ADDS empty, dry	19.532	2.14
ADDS with ALVIN, dry	19.573	2.10
ADDS empty, flooded	19.978	1.69
ADDS with ALVIN, flooded	19.967	1.70
ADDS+DDS, both dry	19.459	2.22
ADDS+DDS, both flooded	20.029	1.65

In all cases, BG was greater than the required minimum of 1 ft, indicating adequate submerged stability. The three conditions with the dry ADDS actually improve stability, because the ADDS provides a net buoyant force rather than a net weight. A potential problem requiring further analysis is whether or not the increased buoyancy decreases the roll period of the SLURV too much. This could have implications in the launching and recovery of ALVIN. However, based on the slight increase in BG, this is unlikely. The three flooded conditions decrease stability slightly because of the added weight on top of the submarine. The most severe stability condition is the ADDS and DDS, both empty and flooded. However, even this condition has a BG well above the required minimum.

4.2 Performance Analysis

4.2.1 SSGN Mission Capability

The SLURV final concept design will affect, at most, one SSGN combat mission (see Section 2.5.1 for a description and definition of SSGN combat missions). The ADDS utilizes one of the two existing LOCs for access between the submarine and the ADDS. The other LOC remains available for use by a conventional DDS or ASDS. Figure 17 illustrates this dual capacity.

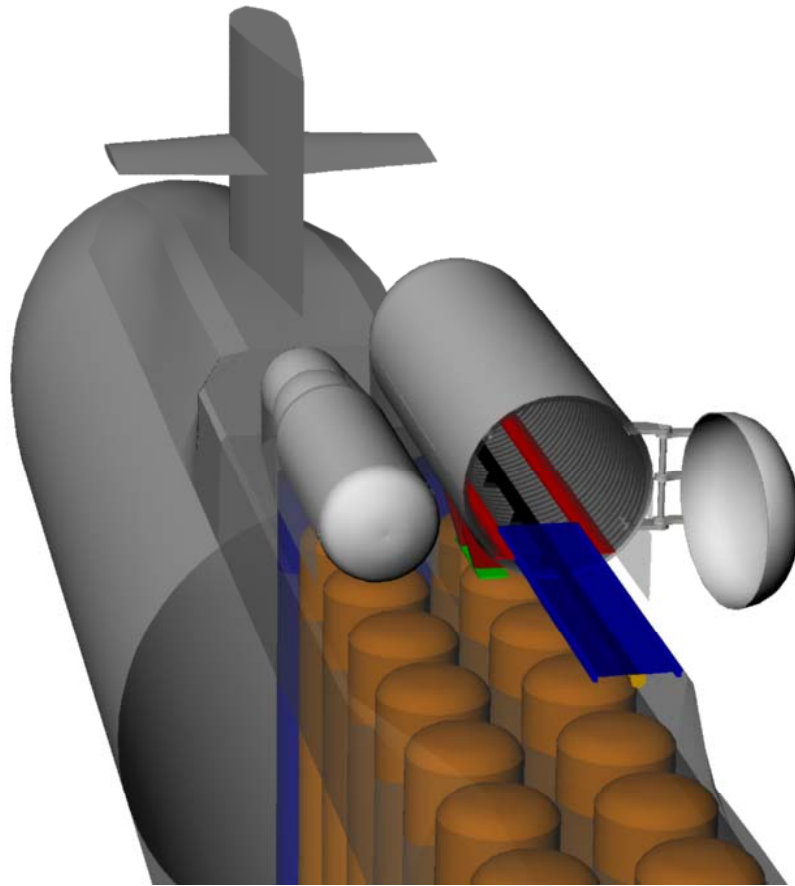

Figure 17. SSGN with DDS and ADDS

The TLAM capability of the SSGN will not be affected any more than with a conventional DDS, since the SLURV modifications will not involve tubes 11-24. The internal modifications to the SSGN are so minor that they will not affect the combat capabilities of the submarine.

The SLURV modifications are intended to be fully modular. This means that the ADDS can be easily removed and the SSGN returned to its baseline configuration, with full combat mission capability. Additionally, the internal modifications are simple enough that they could be completed on all four SSGNs during the SSBN-to-SSGN conversion process or a follow-on scheduled maintenance period. This would allow greater operational flexibility for the SLURV system.

4.2.2 SSGN Speed Reduction

The SSGN Math Model was used to calculate the effect of the ADDS on SSGN submerged speed. The drag force on the ADDS was calculated as described in Section 4.1.9. This additional drag force was added to the drag force of the baseline SSGN to determine the resulting reduction in speed.

The model indicates that the addition of the ADDS will reduce SSGN speed by 5%. This result corresponds closely to the actual results obtained for a conventional DDS mated to an SSN. This correlation lends further credibility to the SSGN Math Model results.

4.2.3 SSGN Acoustic Signature

Because of the limited scope of this project, no acoustic calculations or analyses were performed. However, the ADDS design is nearly identical in shape and proportions to a conventional DDS (mounted on an SSN). The outer skin of the ADDS is smooth and does not contain cavities. Provided that all equipment inside the ADDS is securely fastened to prevent rattles, the major source of noise from the ADDS during transit will be flow noise. Launch and recovery operations will create transients that may be detectable. Because of the similarities to a DDS, it is reasonable to assume that the acoustic effect of the ADDS on an SSGN will be very similar to the acoustic effect of a DDS on an SSN. This effect is considered minimal, and will not significantly alter the acoustic signature of the SSGN.

4.3 Operation and Support

The SLURV will be operated as a modular unit which includes the ADDS, ALVIN, and supporting equipment. When a SLURV mission is initiated, the host ship will be made ready for the mission by removing a DDS or ASDS to provide the necessary space for the ADDS to be attached to one of the LOCs and foundations. The loading and unloading of the ADDS and ALVIN will require a rigging crew and crane support. Additionally, a truck is required to transport the ADDS and ALVIN from its storage location. These services are normally available at U.S. submarine bases. Once the

ADDS is craned on to the SSGN, it must be connected by Intermediate Maintenance Activity (IMA) and ship's force personnel using appropriate Scope of Certification procedures. ALVIN will then be loaded on to the launch and recovery sled and retracted inside the ADDS hangar for storage. Support equipment and supplies will then be loaded by ALVIN crewmembers with support from ship's force personnel. Once equipment has been stowed, the SLURV is ready to conduct the mission.

A typical mission would involve the SLURV transiting to the mission area while remaining submerged and undetected. ALVIN crewmembers would conduct last minute operational and system checks during the transit while the hangar and ALVIN remain dry. When the SLURV arrives on station, the pilot, two observers, and Expedition Leader would enter the ADDS hangar through the associated LOC. The crewmembers would enter ALVIN through the top hatch and ensure all systems are ready. The Expedition Leader would ensure the ALVIN hatch is shut and personnel are clear of the hangar. Upon exiting the ADDS, the Expedition Leader establishes communications with ALVIN via the fiber optic link and the ADDS is then flooded. The hangar is equalized with sea pressure and the outer door is hydraulically opened, allowing the launch and recovery sled to extend out of the hangar. Once outside the hangar, ALVIN personnel control the release mechanism that allows ALVIN to operate freely. ALVIN will then perform its assigned mission of up to ten hours in duration. When the mission is complete, ALVIN will rendezvous with the SSGN. It will land on the launch and recovery sled and be remotely retracted into the open hangar. The hangar door will be hydraulically shut and the ADDS will be drained, allowing the ALVIN crewmembers to exit the submersible. For repeated missions, required maintenance will be conducted on ALVIN, including the charging of batteries, replacement of oxygen bottles, and the filling of oil systems. Once maintenance is complete, ALVIN can be launched on another mission using the second set of crewmembers.

Upon completion of the SLURV mission(s), the system will be removed in the same manner it was installed. The ADDS, ALVIN, and support equipment can be off-loaded at the port of origin, or be dropped off at another port with appropriate support services. Once the equipment is removed, the SSGN can be restored to its original configuration and return to normal mission status.

Casualty operations for ALVIN or the ADDS involve two main scenarios. The first scenario involves a casualty on board ALVIN that requires the submersible to go to the surface. This could be as a result of flooding or other system failure. For emergency surfacing, ALVIN is equipped with descent weights that can be jettisoned from the vessel, causing it to become positively buoyant and ascend to the surface. ALVIN will also be equipped with an inflatable sail to provide adequate freeboard over the hatch while on the surface. In the case of an emergency surfacing, the host SSGN would surface in the vicinity of ALVIN and provide lifeguard services and possible evacuation of crewmembers. ALVIN would not be able to return to the ADDS while on the surface, and would have to be recovered by another support ship. The second scenario involves a casualty where ALVIN was trapped inside a flooded ADDS. In this case, an attempt would be made to close the outer hangar door and drain the ADDS with ALVIN inside. Once the hangar was drained, ALVIN crewmembers could be evacuated from the ADDS. If the hangar door could not be closed and it remained flooded, the SSGN would surface with ALVIN still attached in the ADDS. Once on the surface, gravity would cause the water to drain from the ADDS and the ALVIN crewmembers could then be evacuated.

4.4 Rough Cost Estimate

The cost for converting an SSGN to a SLURV system was broken down into three major cost areas:

- ADDS Construction
- SSGN Modifications
- ALVIN Modifications

To get a rough estimate of each of these cost areas, the ‘Very Simplified Cost Model’ portion of the MIT Submarine Math Model [7] was used. This is a weight-based parametric model that calculates the cost of labor, material, overhead, and profit to provide a rough estimate of the overall construction cost. Table 15 shows the parameters used in the model for this design.

Table 15. Cost Estimating Parameters

Labor Rate	\$150 per man-hour
Overhead Factor	1.5
Profit Rate	0.11

The cost estimating parameters were taken from recent submarine design and construction trends and course notes from Reference 5.

The three cost areas were each evaluated separately and then combined for an overall cost. The major costs associated with the ADDS construction were associated with the structural cost of the hangar itself. Weights for electrical and auxiliary components of the ADDS were taken to be a percentage of the overall weight of the system. The major costs associated with the SSGN modifications were involved in the changes to the hydraulic and electrical systems required to support the ADDS. An estimate was made for the weight of these modifications and was then entered in the model. For the SSGN modifications, labor and integration were increased by a factor of three from the baseline, due to the difficulty of performing modifications on an already existing platform. Finally, the costs associated with ALVIN modifications were based on the minor changes to remove the sail on ALVIN and realign the mounting of the batteries. Details of the cost models are found in Appendix I.

After developing a cost model for each area of the conversion, the totals were summed to develop an overall cost of the conversion project for an SSGN to host ALVIN. A summary is provided in Table 16.

Table 16. Cost of Conversion Project

		ADDS	SSGN Mods	ALVIN
Direct Cost	Labor	\$9.89	\$0.80	\$0.15
	Material	\$1.95	\$0.28	\$0.03
Indirect Cost	Overhead	\$17.76	\$4.00	\$0.28
	Profit	\$3.25	\$0.73	\$0.05
		\$32.85	\$5.81	\$0.51

Total Cost: \$39.17

** All figures in \$M*

Page Intentionally Left Blank

5.0 Design Conclusions

5.1 Summary of Final Concept Design

The Submarine Launched Undersea Research Vessel final concept design consists of an OHIO class (SSGN) Submarine, modified to host the submersible ALVIN. The primary modification was the design and construction of an ALVIN Dry Deck Shelter (ADDS) that would attach to LOC 1 or 2 in a manner similar to the current Dry Deck Shelter (DDS). The ADDS would be larger than the current design to allow ALVIN to be housed in a dry shelter during transit. Table 17 lists the principle characteristics of the SLURV.

Table 17. Submarine Launched Undersea Research Vessel Characteristics

Modified SSGN (ADDS & ALVIN installed)	
Length	560 ft
Diameter	42 ft
Displacement	16,600 ltons (surfaced) 18,750 ltons (submerged)
Draft	34.57 ft
BG	1.70 ft (submerged, flooded)
GM _T	1.65 ft (surfaced, dry)
Reserve Buoyancy	14.0%
Propulsion	60,000 hp
Speed Reduction	5% (submerged)
Crew (SSGN)	155
ALVIN Crew	8
ADDS Characteristics	
LOA	46 ft
Length of Hangar	35 ft
Diameter	14 ft (outside diameter)
Weight	58.5 ltons
Displacement	195.0 ltons
Design Depth	Test depth of SSGN
Conversion Cost	
ADDS Construction	\$32.85 M
SSGN Modifications	\$5.81 M
ALVIN Modifications	\$0.51 M
<i>Total Conversion</i>	<i>\$39.17 M</i>

5.2 Final Conversion Design Assessment

The SLURV final concept design meets or exceeds all design thresholds and design objectives defined in Section 2.3. Table 18 summarizes the design goals and actual performance of the SLURV final concept design.

Table 18. Comparison of Final Concept Design to Design Objectives

SLURV Design Parameters	Threshold	Goal	Concept Design
SSGN Mission Capability	Affect 2 missions	No effect	Affect 1 mission*
ALVIN Mission Capability	3 ALVIN missions	Unlimited	10 ALVIN missions
Depth Limit for Transfer Operations	200 ft	Test depth of SSGN	Test depth of SSGN
SSGN Speed Reduction	30%	0%	5%
Submarine Design Objectives			
Reserve Buoyancy	12%	--	14%
Margin Lead	No less than baseline SSGN	--	Same as baseline SSGN
BG	1.0 ft	--	1.70 ft
Acoustic Signature	Equal to baseline SSGN	--	Equal to baseline SSGN

*only while ADDS is installed

The SLURV modifications will not permanently affect the mission capabilities of the SSGN. When installed, the ADDS will occupy one LOC and will therefore remove the capability to carry one DDS or ASDS. The other LOC will remain available for use. Preliminary analysis shows that the SLURV can operate and remain stable with both ADDS and a conventional DDS attached. The SLURV modifications will not affect the ship's TLAM capability any more than a DDS or ASDS.

The installation of the ADDS on the SSGN will create a submerged speed reduction of approximately 5%. This reduction is similar to the effect of a DDS on an SSN, and will not significantly degrade the performance of the ship. The acoustic signature of the SLURV will be very similar to that of the baseline SSGN, with the exception of transients caused during ALVIN launch or recovery operations.

Based on the results of this study, the design team concludes that the proposed SLURV concept design is feasible. All design thresholds and objectives were met or exceeded. The entire conversion project will cost approximately \$39.17 M.

5.3 Areas for Further Study

This project was a preliminary investigation into the feasibility of the SLURV concept. Many areas of design or analysis require additional analysis. Specific items for further study include:

- Detailed hydrodynamic analysis of the ADDS to determine speed and acoustic effects
- Detailed calculations of ADDS hydraulic system loads
- Optimization of ADDS geometry to coincide with ALVIN redesign
- Optimization of ADDS structural design
- Analysis of SSGN and ALVIN maneuvering requirements during launch and recovery
- Analysis of ADDS ventilation requirements
- Analysis of SLURV shock performance
- Detailed cost model for ADDS construction, SSGN modification, and ALVIN modification

Page Intentionally Left Blank

ACKNOWLEDGEMENTS

The authors wish to express their gratitude to Mr. Stuart Mennitt of NAVSEA O5U, who provided overall guidance and direction for the project. CAPT (Sel) Mark Welsh and Mr. Grant Thornton of PMS 398 provided valuable background information on the baseline SSGN. Mr. Robert Brown and Mr. Griff Outlaw supplied information regarding ALVIN specifications and operations.

Page Intentionally Left Blank

REFERENCES

1. Chairman of the Joint Chiefs of Staff, Joint Vision 2020 (Washington, D.C.: US Government Printing Office, 2000).
2. Chief of Naval Operations, Sea Power 21: Operational Concepts for a New Era, Naval War College, Current Strategy Forum, 12 June 2002.
3. *United States Navy Fact File: NR-1 Deep Submergence Craft*. 1999.
www.chinfo.navy.mil/navpalib/factfile/ships/ship-nr1.html
4. *National Oceanic and Atmospheric Administration, Submersible Technology File: ALVIN*, August 2002. oceanexplorer.noaa.gov/technology/subs/alvin/alvin.html.
5. Jackson, Harry A., CAPT, USN, Ret. "Submarine Design Trends." Massachusetts Institute of Technology Professional Summer Class Notes, Cambridge, MA, June 2002.
6. Wilson, Brian M., SSGN Design Manager. "Post-SSGN Payload Study Design Overview." January 2002.
7. Reed, Jeffrey and Mark Welsh. "Massachusetts Institute of Technology XIII-A Submarine Math Model." June 2002.
8. Jane's Fighting Ships, Ed. 155, 2002-2003, Jane's Information Group Limited. Surrey, UK, 2002.
9. *Woods Hole Oceanographic Institution, Marine Operations, Vehicles File: ALVIN*, January 2003. www.whoi.edu/marops/vehicles/alvin/index.html
10. "Overview of SSGN Special Operations Forces (SOF) Attributes on SSGN", presentation by General Dynamics-Electric Boat, 12 November 2002.
11. Johnson, Dave. "Program to Compute Suitability of Submarine Design Parameters." May 2001.
12. Naval Sea Systems Command, System Certification Procedures and Criteria Manual for Deep Submergence Systems, NAVSEA SS800-AG-MAN-010/P-9290, Revision A, November 1998.
13. Hoerner, S. F. Fluid-Dynamic Drag: Theoretical, Experimental, and Statistical Information. Hoerner Fluid Dynamics, Bakersfield, CA, 1992.

14. Daniels, Kirk, Supervisor of Naval Architecture. "SSGN Program Review, Dec. 9, 2002: Weight and Ballasting." December 2002.
15. Advanced Seal Delivery System SSGN Submarine Interface Specification, Draft, obtained from NAVSEA PMS 398.
16. SSGN Dry Deck Shelter Interface Control Document, General Dynamics Electric Boat Corporation, December 3, 2002, obtained from NAVSEA PMS 398.

APPENDICES

Page Intentionally Left Blank

APPENDIX A : Mission Need Statement

Mission Need Statement
For
Submarine Launched Undersea Research Vessel

1. Defense Planning Guidance Element. This Mission Need Statement provides requirements for deep-sea research vessels for the 21st Century. This Mission Need Statement should guide research/host vessel design, research, development, and acquisition program decisions.

2. Mission Analysis

A. Mission. The general mission of this ship is to perform specialized military and scientific missions in deep water and on the ocean floor using a manned deep-sea research vessel, ALVIN, to perform missions independent of the host platform. The host ship must be able to independently transit to the mission location, perform military and scientific missions of interest, including the launch, recovery, and support of ALVIN, and return to its base of operations without additional support from other vessels.

B. Military Mission Needs (ALVIN)

- 1) Systems Manipulation/Implantation/Control. The vessel must be able to implant mission related objects in precise locations and manipulate objects found in the ocean.
- 2) Recovering Objects. The vessel must be able to recover objects that have been located by onboard or off-board sensors.
- 3) Disabling/Removing Objects. The vessel must be able to manipulate and/or remove objects of military interest.
- 4) Area Survey/Investigation. The vessel must be able to locate objects of military importance within its operating area.
- 5) Support to Military Research and Development. The vessel will be an integral part of Department of Defense research and development related to the ocean.

C. Scientific Mission Needs. The vessel must be able to conduct research in a variety of scientific fields including:

- 1) Physical Oceanography.
- 2) Geology/Geophysics.
- 3) Marine Biology.
- 4) Atmospheric Science.
- 5) Ocean Engineering
- 6) Chemical Oceanography
- 7) Maritime Archeology
- 8) Environmental Science

D. Capabilities and Requirements of the host ship or ALVIN

- 1) Host ship operational depth not affected by ALVIN during transit operations. Launch/recovery depth limits may be implemented.
- 2) Operation, including launch and recovery, in 1.5 knot current at launch/recovery depth.
- 3) Assume host of single ALVIN submersible and support equipment.
- 4) Maximize modularity.
- 5) Maintain acoustic signature less than or equal to baseline of host submarine.
- 6) Maintain resistance to underwater shock of host submarine. Payload does not have to be shock hardened.
- 7) Maintain minimum required values for host GM, BG, reserve buoyancy, non-nuclear margin, seawater density range, and loads provided for. If this is not feasible, quantify trade-offs.

3. Non-Material Alternatives

A. Any system capable of performing this mission will require significant material development.

B. Changes in operational doctrine will not accomplish these missions.

4. Potential Material Alternatives

A. A deep-sea submarine is the only type of platform capable of performing many of these missions.

B. Alternative design concepts include:

- 1) Design of an entirely new class of submarine.
- 2) Modification of a Flight III SSN-688I Design to meet the host requirements.
- 3) Modification of a SEAWOLF Class Design to meet the host requirements.
- 4) Modification of a VIRGINIA Class Design to meet the host requirements.
- 5) Modification of a SSGN Design to meet the host requirements.

C. Design concepts are not limited to U.S. only shipbuilding programs. All meaningful cooperative opportunities with Allied countries should be examined relating to development programs for deep ocean research vessels.

5. Constraints

A. Key Boundary Conditions.

- 1) Architecture - The ship design must employ a total ship architectural/engineering approach that optimizes mission effectiveness and performance; minimizes cost of conversion.
- 2) Design - Consideration should be given to the maximum use of modular designs in the host vessel's infrastructure. Emerging technologies must be accounted for during the developmental phase.

B. Operational Constraints.

- 1) The host vessel must remain fully functional and operational in all environments. Host vessel performance limitations similar to current limitations associated with hosting the Advanced Seal Delivery System (ASDS) and Dry Deck Shelter (DDS) are considered acceptable.
- 2) The host vessel must provide launching and recovery facilities for ALVIN.
- 3) The host vessel must be able to operate in U.S., foreign, and international waters in full compliance with existing U.S. and international pollution control laws and regulations.
- 4) The host vessel must be able to transit through the Panama Canal (PANAMAX).

APPENDIX B : ALVIN Characteristics

Source: Woods Hole Oceanographic Institution web site [9]



Specifications

Length: 7.1 m (23.3 ft.)

Beam: 2.6 m (8.5 ft.)

Operating Depth: 4,500 m (14,764 ft.)

Normal Dive Duration: 6-10 hours

Speeds:

Cruising - 0.8 km/hr (0.5 knot)

Full - 3.4 km/hr (2 knots)

Height: 3.7 m (12.0 ft.)

Draft: 2.3 m (7.5 ft.) surfaced

Gross Weight: 17 metric tons (35,200 lbs.)

Payload: 680 kg (1,500 lbs.)

Complement:

Pilot - 1

Scientific Observers - 2

Pressure Hull: 208 cm (82 in.) OD, 4.9 cm (1.9 in.) thick titanium

Hatch Opening: 48.2 cm (19 in.) max. diameter for science equipment

Total Power: 46.8 KWH maximum (120V x 390 AH), 35 KWH usable (120V x 292 AH)

Max. Cruising Range: 5 km (3 miles) submerged @ 14 meters/minute

Life Support Duration: 216 man-hours (72 hrs. x 3 persons)

Alvin was constructed in 1964 by the Applied Sciences Division of Litton Industries with funds provided by the Office of Naval Research. The submersible remains state-of-the-art due to numerous reconstructions and improvements made over the years. These improvements make possible the complex operations which *Alvin* is capable of performing today.

Alvin is capable of the following:

- Operating at any depth from the surface to 4,500 meters (14,764 ft.) at speeds of 0-3.4 km/h (0-2.0 knots), and remaining submerged for approximately 10 hours (72 hours under emergency conditions).
- Carrying one or two observers and various internal and/or external instrumentation and tools.
- Maneuvering within areas of rugged bottom topography.
- Hovering at neutral buoyancy in mid-water and/or resting on the bottom to perform scientific and engineering tasks, including still and video photography.
- Using its manipulators and storage basket to deploy various scientific tools and to collect samples.
- Providing a limited amount of electric and hydraulic power plus data logging capabilities for instruments and equipment not normally part of the submersible.

The depth capability is based on a design collapse depth of 5,720 meters for the personnel sphere. A duplicate sphere, however, has been tested to the equivalent of 6,850 meters (22,475 ft.) without failure.

Alvin's 1,500 lb. payload includes the pilot, two passengers, the manipulators, and the science basket. The port and starboard manipulators each weigh 117 lbs. in water. The empty science basket weighs approximately 105 lbs. in water. The remaining payload is available for user equipment and samples taken during the dive. This load may be divided between internally and externally loaded equipment, subject to some restrictions. Internally mounted equipment must fit in a standard 19-inch panel rack. All equipment entering the sphere must pass through a 19-inch circular opening so as to fit through the hatch with adequate clearance. With advance planning, the user's portion of the payload can be increased by the removal of one or both manipulators, the science basket, or one observer.

Normal dive duration varies from six to ten hours, but this time may be reduced by excessive 120V or 26V power usage. The primary direct consumers of the 120V power are the propulsion system and external lights. High speed or current-fighting transits and excessive use of the lights represent loads on the 120V system that

might be avoidable with proper dive planning. The 26V power, derived from the 120V batteries, supplies all services within the sphere (including 110 VAC power) as well as the control systems, instruments and the computers. Judicious use of other instruments such as the CTFM sonar and underwater telephone can result in significant power savings and can thus prolong dive time.

During any given dive, the percentage of time actually spent on the bottom or at desired depths depends upon the amount of time it takes to travel to and from that depth. As a rule of thumb subtract 1.25 hours from the total dive time for each 1,000 meters of depth. The difference will be a rough estimate of total working time on the bottom (i.e. for a ten-hour dive to 4,500 meters, 5.6 hours will be spent in vertical transits leaving 4.4 hours of "bottom time").

Dive duration may also be affected by the need to perform launch and recovery operations during daylight hours in all but the best of weather conditions. Additionally, deteriorating weather conditions may require the early termination of a dive, as may any malfunction which could affect safety or the continuation of operations. The Expedition Leader, with advice from the Pilot and Surface Controller, is responsible for making decisions based on these factors.

Personnel on any given dive are normally one pilot and two observers. In certain cases, such as where bottom conditions are unknown or where extremely rugged terrain and high currents are anticipated, the Expedition Leader may choose to assign two pilots to the dive. Also, the user may elect to assign only one observer to a dive in order to utilize the extra payload capacity for other purposes. Finally, on one dive out of every five during each cruise, a pilot-trainee or other person designated by the *Alvin* Group must fill one of the two observer positions, leaving only one space for a science user. Although there is flexibility in deciding which specific dives will be of this type, it is recommended that the pilot training dives not be postponed to the end of the cruise, but rather, that science program planning allow them to be completed routinely on every fifth dive.

The potential user must carefully consider which aspects of the proposed research require use of the submersible and how it can best be utilized to realize dive objectives. Frequently, extensive investigations are required prior to an *Alvin* cruise in order to ensure the availability of adequate information for conducting an efficient diving program. Additionally, the capabilities of *Atlantis* beyond those of supporting the submersible should be considered in order to maximize the value of the cruise and to minimize the effect of dive time lost due to unforeseen problems. Generally, *Alvin* should be used to accomplish those tasks which cannot be accomplished with

other available oceanographic tools.

Alvin has proven most effective when used in a well planned, coordinated program, where its abilities to observe directly, photograph selectively, and sample in situ are complemented by other research techniques. Due to its slow speed and limited power, *Alvin* is not an effective vehicle for large area searches and surveys.

Manipulators

Alvin is fitted with two jettisonable, hydraulically powered manipulators. The figures below illustrate the working range of these manipulators superimposed on the horizontal field of view from *Alvin's* viewports and the manipulators in elevation view with information on their geometry.

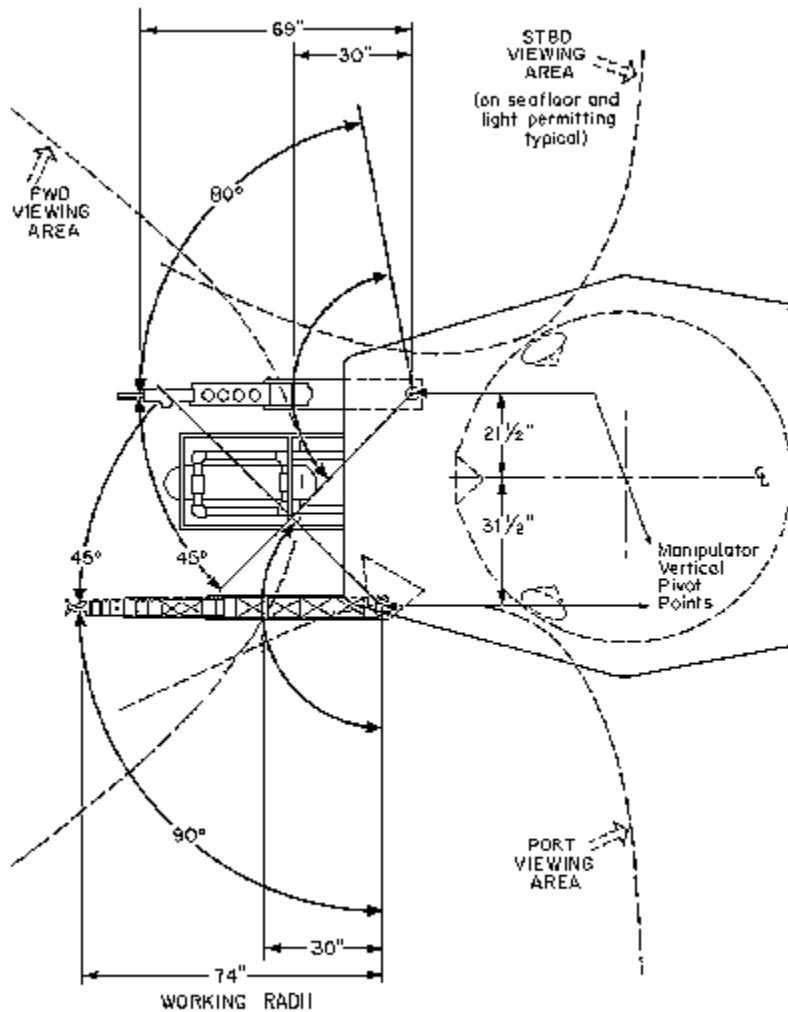

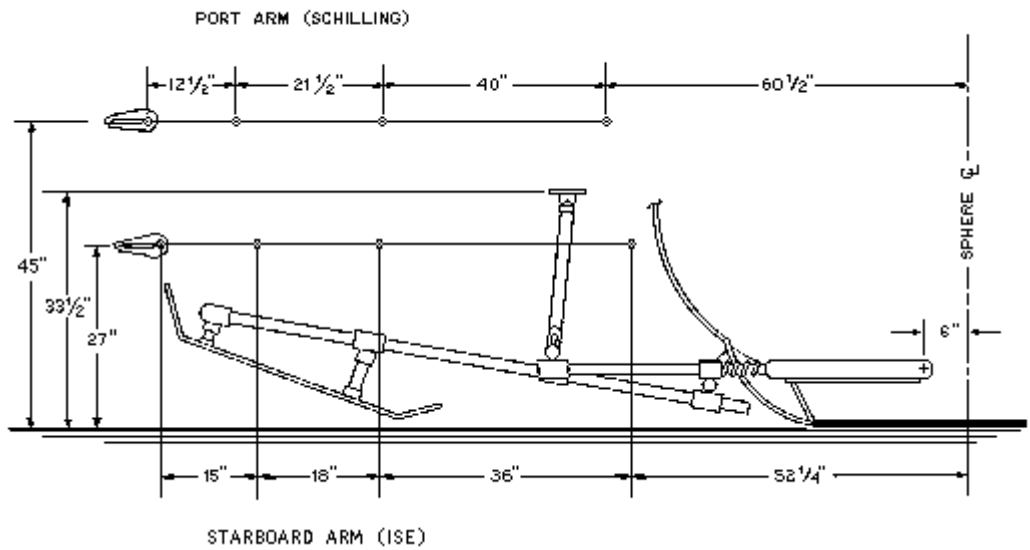

The starboard manipulator has six degrees of movement: shoulder pitch and yaw, elbow pitch, wrist pitch and rotate, and hand open and close. The arm can be fitted with a hydraulic actuator that can be used as a trigger mechanism to operate devices held by the hand. Details are shown below. The manipulator has a maximum extension of 69 inches and a lift capacity of 100 pounds at maximum extension. Remote operation is controlled by a switch panel in the personnel sphere. The arm may be viewed from either the front or starboard side viewports during operation.

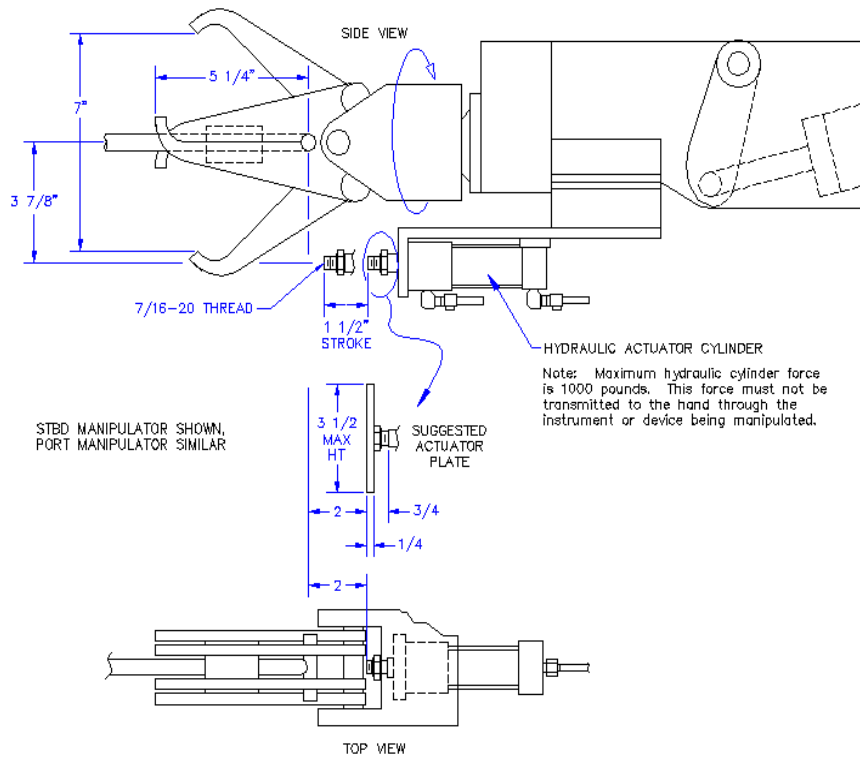

The port manipulator has the same six degrees of movement with the additional capability of wrist yaw. Maximum extension is 74 inches, with a fully extended lift capacity of 150 pounds. Wrist torque is rated at 30 ft/lbs and has a maximum rotational speed of 65 RPM. A second wrist assembly can be installed having half the torque but twice the speed. This arm is controlled by a position feedback master/slave mechanism, with the spatially correspondent master located in the personnel sphere allowing viewing and control through the front and port side viewports. This manipulator can also be fitted with an auxiliary hydraulic ram to trigger special equipment.

The hands of both manipulators are functionally equivalent and consist of opposing overlapping finger pairs. They are specifically designed to grip instruments which are fitted with a standard "T" handle (see below). The user should align the "T" with the vertical load. The user is cautioned not to assume compatibility between his tools and *Alvin's* manipulators, even if the tools are fitted with T handles. It is best to seek the advice of the *Alvin* Group on instruments which have not been previously used with the manipulators, regardless of how dependable they may seem. If it is discovered that the equipment is incompatible with the manipulators in its current state, alterations rendering it acceptable can probably be developed by the *Alvin* Group if given adequate advance notice. Many biologically and geologically oriented tools, including a variety of pry bars and other rock breaking tools, soft and hard sediment corers, box corers and a current meter have been adapted for use in conjunction with the manipulator hands and the actuator mechanism.

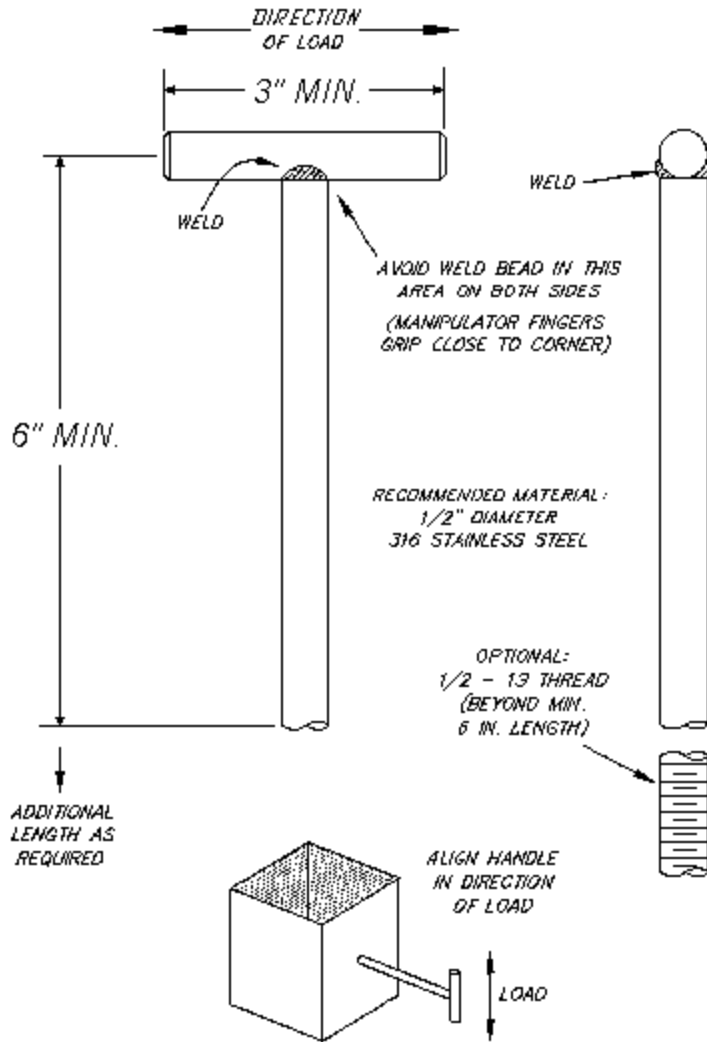

Pressure Hull

The *Alvin* pressure hull has an outside diameter of 82 inches and an inside diameter of 78 inches. The hatch opening is 20 inches in diameter; any equipment which users wish to bring on board must be capable of passing through the hatch with its sealing surface protection ring in place (19" maximum diameter suggested). Four conical acrylic plastic viewports, each 3.5 inches thick with a 5-inch inside diameter and a 12-inch outside diameter, are set at different points in the hull. A fifth, smaller viewport is located in the hatch. The arrangement is shown below, along with photographs of the hull interior. Note that the bottom viewport is always covered by the floorboards and is not useful for observation.

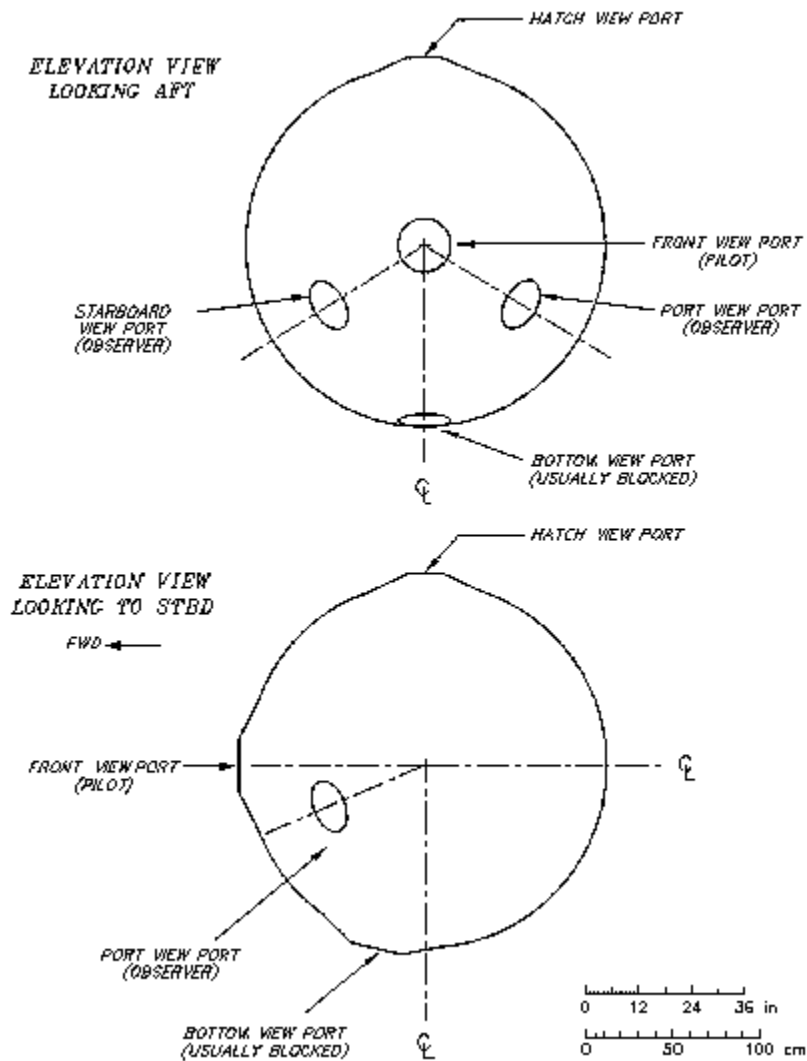

Electrical Systems

Standard 19-inch rack space, up to 35 inches in height, is available for instruments to be mounted inside the pressure hull. This space is variable depending on submersible load. Depth behind the rack varies from 14 to 18 inches, as shown below.

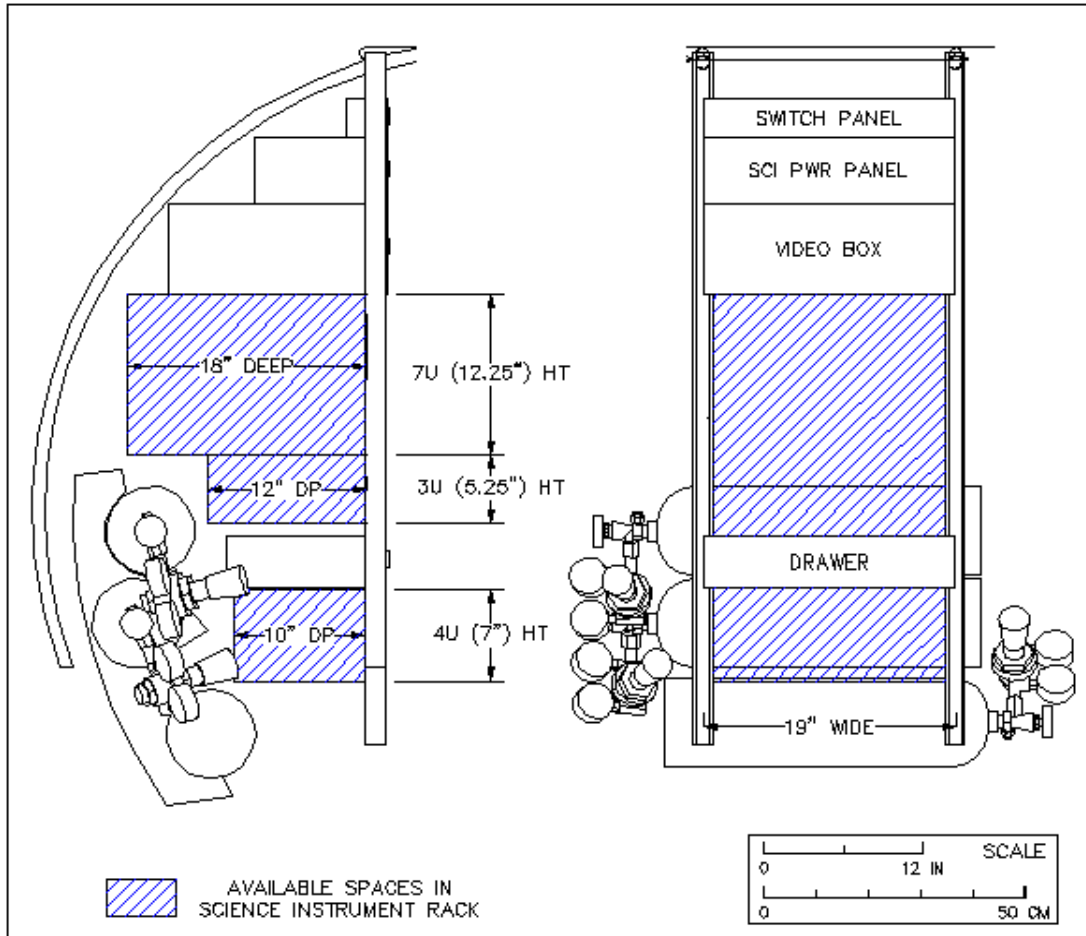

All equipment used inside the personnel sphere must fit through a 19" diameter ring to assure adequate clearance through the hatch. A panel mounted at the top of the science rack contains 12 and 26 VDC power for instruments and the termination of wires entering the hull from the external science basket area and junction boxes.

Four separate 26 VDC power circuits are available on the science panel. One of the circuits has a 10A breaker and three have 5A breakers; two of these circuits are remotely switched from a panel near the starboard observer. 26V power for devices requiring more than 10A is available by connecting directly to the 50A breaker that supplies the panel. Although the panel breaker is rated at 50A, the actual power available is dependent on other submarine requirements; a total of 100A of 26V is produced, of which 25-50A can be used by permanent equipment in addition to the inverter (described below).

Similarly, there are four 12V circuits with 10A circuit breakers, two of which can be remotely switched; a total of 33 amps of 12V is available.

1,000 watts of 115VAC 60Hz is available from an inverter powered from the 26V bus. At maximum load, the inverter consumes 40A of the available 100A from the 26V bus.

All of *Alvin's* electrical systems and through-hull wiring must be UNGROUNDED to limit the chance for corrosion of structural parts in the event of inadvertent grounding of any conductor. *Alvin's* electrical systems are frequently checked for grounds during each dive. There are four requirements that each science device must meet:

1. No device may permit, or cause, a direct DC path between any source of *Alvin* power and the submarine's hull, frame or seawater.
2. No device connected to through-hull wires may permit any DC path between any through-hull wire and the submarine's hull, frame or seawater.
3. All devices connected to through-hull wires must provide a DC path from an *Alvin* power source to all such through-hull wires so that the submarine's ground detection system can be used to check for inadvertent grounding of through-hull wires. The easiest way to provide this connection is with a resistance of from 0 to 3 Kohms between the instrument's internal ground and the input power common (for DC powered equipment). An alternative to this requirement is for the instrument to provide a means of continuously monitoring the through-hull wires for ground.
4. Isolated or battery-powered equipment **may not** be used to avoid these requirements.

Wires leading from inside the sphere are available for science use and terminate outside the submersible as follows:

Junction ("J") boxes

- Sail (forebody): 25 singles & 2 twisted shielded pairs
- Port (afterbody): 22 singles & 3 twisted shielded pairs
- Starboard (afterbody): 18 singles & 2 twisted shielded pairs

All the wires in the port and starboard J boxes may be extended forward to the science basket disconnect boots.

The figure below shows the general arrangement of these junction boxes.

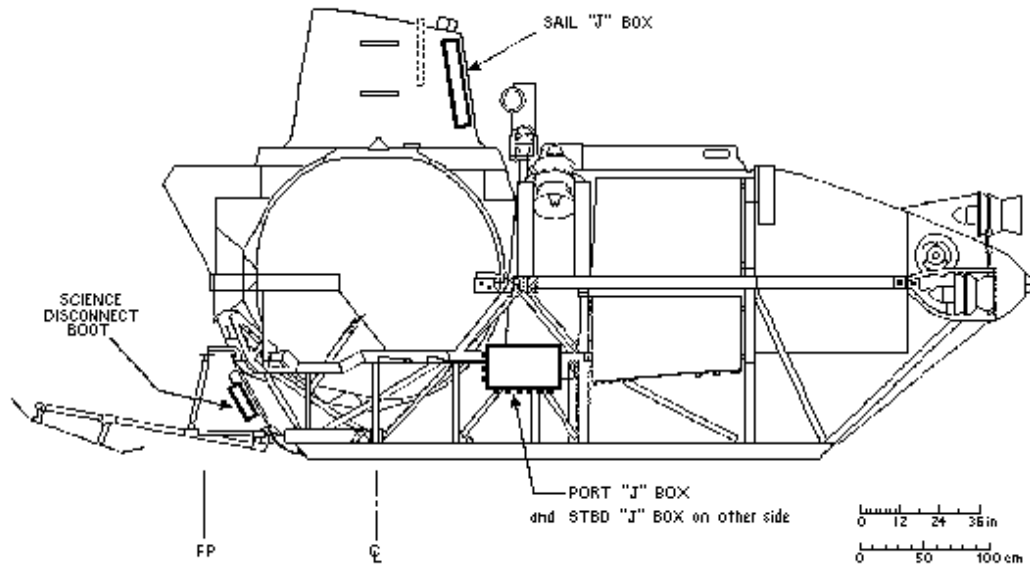

All single wires are #16 AWG and are rated at 13A. Shielded pair wires are #18 AWG. All wires are fused at 10A. Outboard scientific equipment to be wired into any of the above must be fitted with a suitable length (normally 15 feet) of an oil compatible cable; Teflon insulated wire/polyurethane jacketed cable is recommended. Acceptable jacket outside diameters for user-supplied cable are 0.148, 0.290, 0.420, and 0.750 inches, since these sizes will fit standard *Alvin* stuffing tube packing assemblies.

Equipment and devices may be externally mounted on the forebody structure (sponson, light bar, sail). The exact location and mounting method will be at the discretion of the *Alvin* Group. Forebody-mounted equipment must terminate in the Sail J box in order not to interfere with emergency release mechanism of the forebody. Cables from installed devices must be of sufficient length to reach and enter the J box (filled with Bray 726 oil). Cables will enter the J box through a stuffing tube and therefore will fill with compensating oil unless dammed or otherwise blocked. Polyurethane cable jacket is preferred over neoprene/SO types because of its superior oil resistance.

Afterbody-mounted equipment (below viewports, aft of sphere) must terminate in the Port or Starboard J boxes. Science basket-mounted equipment must terminate in one of the three science pull-apart disconnect boots, which allow the basket wiring to separate from the submersible in the event that the basket has to be jettisoned. These disconnects are located on the skin under the forward viewport and are also filled with Bray 726 oil. Wires from science equipment in the basket must be long

enough (15 feet) to reach these disconnects. The figure below shows the general layout of a science disconnect boot.

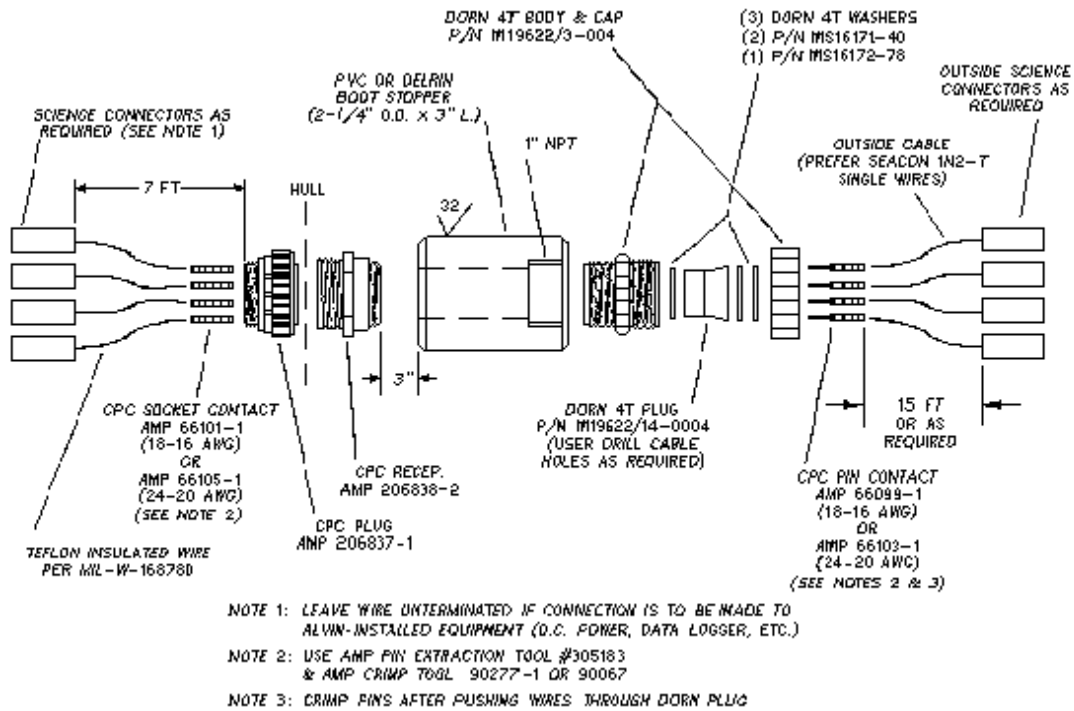

This information is provided to assist the user in preparing wiring harnesses and checking the operation of equipment with the completed harness well in advance of a cruise. The circular plastic (CPC) connectors depicted plug together as well as directly to the *Alvin* through-hull wiring. The *Alvin* wiring has a one-to-one correspondence with these connectors, minimizing the chance of wiring errors which helps expedite final equipment installation. The connectors, pins and tools are available from most major electronics suppliers.

The inboard CPC connector terminates at the top of the science rack, located at the rear of the personnel sphere. Power for science applications is provided in this same panel (see above for number of 12V and 26V circuits). 120VDC service (protected at either 80A or 15A) can be installed outside and controlled from within the sphere to operate afterbody-mounted equipment.

APPENDIX C: FOE and DF Calculations

FOE	Variant					
	1	2	3	4	5	6
Depth Restriction	1	0	1	1	1	1
ALVIN Endurance	0	1	0	1	0	0
Speed Limit	0	0.5	0.5	1	1	0.5
SSGN Mission Capability	0.666	0.666	1	0.666	1	1
DF						
SSGN Modification	1	1	2	2	3	2.5
ALVIN Modification	2	2	2.5	3	2	2.5

Factor of Operational Effectiveness (FOE) and Difficulty Factor (DF)

Variant	FOE	DF
1 - ALVIN attached in manner of ASDS with fairing	0.4	1.3
2 - ALVIN inside large DDS	0.6	1.3
3 - ALVIN attached to MCLET with clamshell doors	0.6	2.15
4 - ALVIN inside missile tube (vertically)	0.9	2.3
5 - Bottom recessed hangar in SSGN	0.7	2.7
6 - ALVIN attached to ERLET with fairing	0.7	2.5

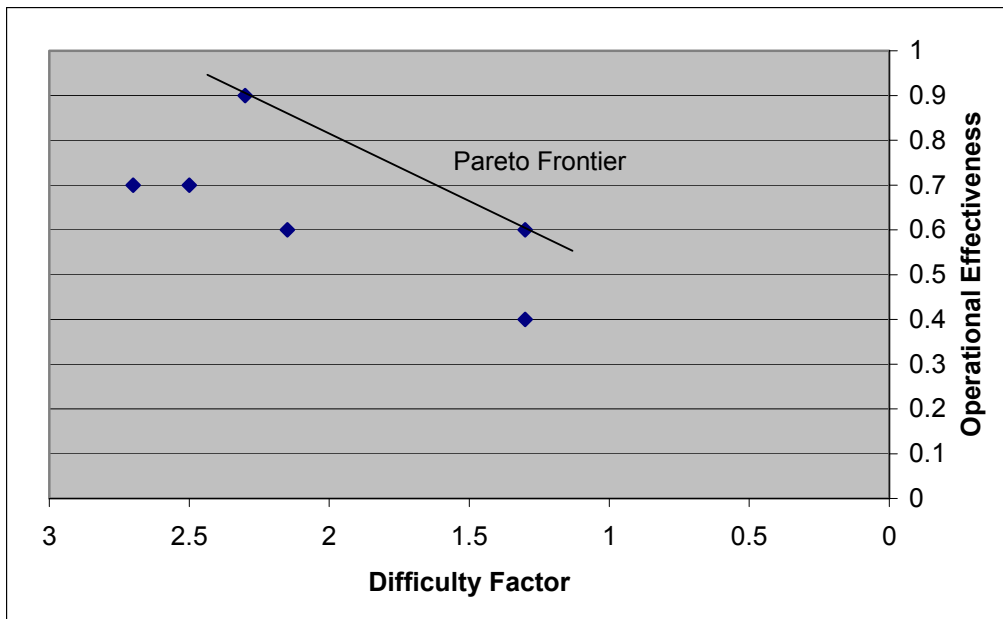

SSGN Conversion FOE/DF Model

AHP Weights

FOE

Difficulty Weighting Factor

DF

Overall FOE
0.600

Overall DF
1.300

	<u>Projected</u>	<u>Remarks</u>
0.200 Speed Limit	0.5	> 25 knots = 1.0 20-25 knots = 0.5 <20 knots = 0.0
0.300 ALVIN Endurance	1	Unlimited = 1.0 Limited = 0.0
0.200 Op. Depth Restraint	0	Unlimited = 1.0 Limited = 0.0
0.300 SSGN Mission Impact	0.666	No Impact = 1.0 Impact 1 Asset = 0.666 Impact 2 Assets = 0.333 Impact 3 Assets = 0.0 An "Asset" is defined as ability to carry ASDS/DDS or Full Tomahawk capability

	<u>Remarks</u>
0.3 ALVIN	2 Easy = 1 Difficult = 3
0.7 SSGN	1 Easy = 1 Difficult = 3

APPENDIX D: SSGN Submarine Math Model

(Results included in report. Refer to MIT 13A Program Office)

APPENDIX E: ADDS Structural Design

(Results included in report. Refer to MIT 13A Program Office)

APPENDIX F: Drag Force Calculations

ADDS Geometry and Constants

Diameter: $d := 14\text{ft}$

Height: $h := 16.5\text{ft}$

Seawater density: $\rho := 1.99 \frac{\text{slug}}{\text{ft}^3}$

Conversion: $\text{knot} := 1.688 \frac{\text{ft}}{\text{s}}$

Speed: $U := 30\text{-knot}$

Drag Coefficient: $C_D := .2$

Kinematic viscosity of seawater: $\nu := 1.26 \times 10^{-5} \frac{\text{ft}^2}{\text{s}}$

Reynolds Number Calculation

$$R_d := U \cdot \frac{d}{\nu} \qquad R_d = 5.627 \times 10^7$$

Reynolds number indicates turbulent flow.
Choice of $C_D=0.2$ is correct.

ADDS Drag Calculation

$$D_{\text{ADDS}} := .5 \cdot \rho \cdot C_D \cdot U^2 \cdot d \cdot h$$

$$D_{\text{ADDS}} = 1.179 \times 10^5 \text{ lbf}$$

DDS Drag Calculations

$$d := 9\text{ft}$$

$$h := 11.5\text{ft}$$

$$D_{\text{DDS}} := .5 \cdot \rho \cdot C_D \cdot U^2 \cdot d \cdot h$$

$$D_{\text{DDS}} = 5.282 \times 10^4 \text{ lbf}$$

$$\text{ratio} := \frac{D_{\text{ADDS}}}{D_{\text{DDS}}}$$

$$\text{ratio} = 2.232$$

APPENDIX G: Hold-down Bolt Shear Stress Calculations

Transfer Trunk Bolts

Bolt Diameter: $d_1 := 1.75 \text{ in}$

Number of Bolts: $n_1 := 32$

Bolt Area: $A_1 := n_1 \cdot \frac{\pi}{4} \cdot d_1^2$

Pedestal Foot Bolts

Bolt Diameter: $d_2 := 2.25 \text{ in}$

Number of Bolts: $n_2 := 12$

Bolt Area: $A_2 := n_2 \cdot \frac{\pi}{4} \cdot d_2^2$

Total Bolt Area

$$A := A_1 + A_2 \qquad A = 124.682 \text{ in}^2$$

Stress Calculation

Drag Force: $D := 117900 \text{ lbf}$

Shear Stress: $\tau := \frac{D}{A}$

$$\tau = 945.606 \text{ psi}$$

Factor of Safety

K-Monel yield stress: $\sigma_y := 160 \cdot 10^3 \text{ psi}$

Factor of Safety: $FS := \frac{\sigma_y}{\tau}$

$$FS = 169.204$$

APPENDIX H: ADDS Weight and Volume Calculations

ADDS Weight and Volume Calculations

1. Structural Design Inputs

Material: $\sigma_y \equiv 80000 \frac{\text{lb}_f}{\text{in}^2}$ $\rho_{st} \equiv 0.283 \frac{\text{lb}_f}{\text{in}^3}$ $E \equiv 29.5 \cdot 10^6 \frac{\text{lb}_f}{\text{in}^2}$ $\nu \equiv 0.3$

Geometry:

shell diameter	$D \equiv 14.0 \text{ ft}$	$R \equiv \frac{D}{2}$	flange tickness	$t_f \equiv .75 \text{ in}$
frame spacing	$L_f \equiv 12 \text{ in}$		flange width	$w_f \equiv 4.4 \text{ in}$
bulkhead spacing	$L_s \equiv 35 \text{ ft}$		web thickness	$t_w \equiv .4 \text{ in}$
shell thickness	$t_p \equiv 1 \text{ in}$		web height	$h_w \equiv 5.5 \text{ in}$

2. Weight Calculations

$\rho_{ton} := 2240 \text{ lb}_f$

Shell Weight:

Shell Volume

$R_o := R$ $R_i := R - t_p$

$V_{shell} := \pi (R_o^2 - R_i^2) \cdot L_s$ $V_{shell} = 2.204 \times 10^5 \text{ in}^3$

Weight of Shell

$Wt_{shell} := V_{shell} \cdot \rho_{st}$ $Wt_{shell} = 62359.42 \text{ lb}_f$

Stiffner Weight:

Number of Stiffners $Num := 35$

Web

$R_{ow} := R_i$ $R_{iw} := R_{ow} - h_w$

$V_{web} := \pi (R_{ow}^2 - R_{iw}^2) \cdot t_w$ $V_{web} = 1.109 \times 10^3 \text{ in}^3$

Flange

$R_{of} := R_{iw}$ $R_{if} := R_{of} - t_f$

$V_{flange} := \pi (R_{of}^2 - R_{if}^2) \cdot w_f$ $V_{flange} = 1.599 \times 10^3 \text{ in}^3$

Stiffner Volume

$V_{stiffner} := (V_{web} + V_{flange}) \cdot Num$ $V_{stiffner} = 9.48 \times 10^4 \text{ in}^3$

Weight of Stiffners

$Wt_{stiffner} := V_{stiffner} \cdot \rho_{st}$ $Wt_{stiffner} = 26827.15 \text{ lb}_f$

Cylinder Weight:

$Wt_{cylinder} := Wt_{shell} + Wt_{stiffner}$

$Wt_{cylinder} = 8.919 \times 10^4 \text{ lb}_f$ $Wt_{cylinder} = 39.815 \text{ lton}$

Hemispherical End Weight:

Hemi Volume

$$V_{\text{hemi}} := \frac{4}{3} \cdot \pi \left(R_o^3 - R_i^3 \right)$$

Assume each end is half sphere.

$$W_{\text{tends}} := V_{\text{hemi}} \rho_{\text{st}}$$

$$W_{\text{tends}} = 24795.59 \text{bf}$$

$$W_{\text{tends}} = 11.069 \text{ton}$$

DDS Hangar Weight:

Additional weight for transfer trunk, hinges, fairing hold-downs, launch/retrival system, etc.:

$$A := .15$$

$$W_{\text{thangar}} := (W_{\text{tcylinder}} + W_{\text{tends}})$$

$$W_{\text{tadd}} := W_{\text{thangar}} \cdot A$$

$$W_{\text{thangar}} = 50.885 \text{ton}$$

Total DDS Weight:

$$W_{\text{total}} := W_{\text{thangar}} + W_{\text{tadd}}$$

$$W_{\text{total}} = 131079.49 \text{bf}$$

$$W_{\text{total}} = 58.518 \text{ton}$$

3. Volume Calculations

Volume of Cylinder:

$$V_{\text{cylinder}} := \pi \cdot R_o^2 \cdot L_s$$

$$V_{\text{cylinder}} = 5387.83 \text{ft}^3$$

Volume of Ends:

$$V_{\text{ends}} := \frac{4}{3} \pi \cdot R_o^3$$

$$V_{\text{ends}} = 1436.76 \text{ft}^3$$

Total DDS Volume:

$$V_{\text{total}} := V_{\text{cylinder}} + V_{\text{ends}}$$

$$V_{\text{total}} = 6824.59 \text{ft}^3$$

Total DDS Displacement:

$$\Delta_{\text{DDS}} := \frac{V_{\text{total}}}{35 \cdot \frac{\text{ft}^3}{\text{ton}}}$$

$$\Delta_{\text{DDS}} = 194.988 \text{ton}$$

APPENDIX I: Simplified Cost Model

ADDS:

Approximate Weights: **Overall Weight of ADDS = 58.518 Itons (APP G)**

$W_1 := 49.155\text{ton}$	Hull	--based on ADDS overall weight minus auxillaries
$W_2 := 0\text{ton}$	Propulsion	
$W_3 := .585\text{ton}$	Electrical	--based on 1% of overall weight of ADDS
$W_4 := 0\text{ton}$	Command & Control	
$W_5 := 8.778\text{ton}$	Auxillaries	--based on 15% of overall weight of ADDS
$W_6 := 0\text{ton}$	Outfitting	
$W_7 := 0\text{ton}$	Armament	

Establish Cost units: $\text{Bdol} := 1000\text{Mdol}$ $\text{Kdol} := \frac{\text{Mdol}}{1000}$ $\text{dol} := \frac{\text{Kdol}}{1000}$

A. Additional characteristics:

Ship Service Life: $L_S := 30$ Initial Operational Capability: $Y_{\text{IOC}} := 2010$
 Total Ship Acquisition: $N_S := 1$ Production Rate (per year): $R_P := 1$

B. Inflation:

Base Year: $Y_B := 2000$ $iy := 0.. Y_B - 2001$

Average Inflation Rate (%): $R := 3.5$
 (from 2000)

$$F_I := \prod_{iy} \left(1 + \frac{R}{100} \right) \quad F_I = 1.071$$

C. Labor Cost:

Man Hour Rates Taken from MIT Professional
 Summer Submarine Math Model - 2002

$$\text{Mh} := \frac{150\text{dol}}{\text{hr}}$$

Structure	$K_{N1} := \frac{486\text{hr}}{\text{ton}}$	$C_{L1} := K_{N1} \cdot W_1 \cdot \text{Mh}$	$C_{L1} = 3.583\text{Mdol}$
+ Propulsion	$K_{N2} := \frac{560\text{hr}}{\text{ton}}$	$C_{L2} := K_{N2} \cdot W_2 \cdot \text{Mh}$	$C_{L2} = 0\text{Mdol}$
+ Electric	$K_{N3} := \frac{1838\text{hr}}{\text{ton}}$	$C_{L3} := K_{N3} \cdot W_3 \cdot \text{Mh}$	$C_{L3} = 0.161\text{Mdol}$
+ Command, Control, Surveillance	$K_{N4} := \frac{3066\text{hr}}{\text{ton}}$	$C_{L4} := K_{N4} \cdot W_4 \cdot \text{Mh}$	$C_{L4} = 0\text{Mdol}$

+ Auxiliary	$K_{N5} := \frac{1278 \text{ hr}}{\text{tton}}$	$C_{L5} := K_{N5} \cdot W_5 \cdot \text{Mh}$	$C_{L5} = 1.683 \text{ Mdol}$
+ Outfit	$K_{N6} := \frac{1470 \text{ hr}}{\text{tton}}$	$C_{L6} := K_{N6} \cdot W_6 \cdot \text{Mh}$	$C_{L6} = 0 \text{ Mdol}$
+ Armament	$K_{N7} := \frac{810 \text{ hr}}{\text{tton}}$	$C_{L7} := K_{N7} \cdot W_7 \cdot \text{Mh}$	$C_{L7} = 0$

D. Material Cost:

Structure	$K_{M1} := \frac{8.513 \text{ Kdol}}{\text{tton}}$	$C_{M1} := F_I \cdot K_{M1} \cdot W_1$	$C_{M1} = 0.448 \text{ Mdol}$
+ Propulsion	$K_{M2} := \frac{55.61 \text{ Kdol}}{\text{tton}}$	$C_{M2} := F_I \cdot K_{M2} \cdot W_2$	$C_{M2} = 0 \text{ Mdol}$
+ Electric	$K_{M3} := \frac{99.36 \text{ Kdol}}{\text{tton}}$	$C_{M3} := F_I \cdot K_{M3} \cdot W_3$	$C_{M3} = 0.062 \text{ Mdol}$
+ Command, Control, Surveillance	$K_{M4} := \frac{78.23 \text{ Kdol}}{\text{tton}}$	$C_{M4} := F_I \cdot K_{M4} \cdot W_4$	$C_{M4} = 0 \text{ Mdol}$
+ Auxiliary	$K_{M5} := \frac{107.6 \text{ Kdol}}{\text{tton}}$	$C_{M5} := F_I \cdot K_{M5} \cdot W_5$	$C_{M5} = 1.012 \text{ Mdol}$
+ Outfit	$K_{M6} := \frac{125.6 \text{ Kdol}}{\text{tton}}$	$C_{M6} := F_I \cdot K_{M6} \cdot W_6$	$C_{M6} = 0 \text{ Mdol}$
+ Armament	$K_{M7} := \frac{8.251 \text{ Kdol}}{\text{tton}}$	$C_{M7} := F_I \cdot K_{M7} \cdot W_7$	$C_{M7} = 0 \text{ Mdol}$

E. Integration & Assembly:

+ Integration (16.4% of labor and 4% of Material)

$$C_{L8} := .164 \sum_{i=1}^7 C_{L_i} \quad C_{L8} = 0.89 \text{ Mdol}$$

$$C_{M8} := .04 \sum_{i=1}^7 C_{M_i} \quad C_{M8} = 0.061 \text{ Mdol}$$

+ Assembly (65.8% of labor and 24% of Material)

$$C_{L_9} := .658 \sum_{i=1}^7 C_{L_i}$$

$$C_{L_9} = 3.571 \text{Mdol}$$

$$C_{M_9} := .24 \sum_{i=1}^7 C_{M_i}$$

$$C_{M_9} = 0.365 \text{Mdol}$$

E. Direct Costs:

1. Labor Cost:

$$C_L := \sum_{i=1}^9 C_{L_i}$$

$$C_L = 9.889 \text{Mdol}$$

2. Material Cost:

$$C_M := \sum_{i=1}^9 C_{M_i}$$

$$C_M = 1.949 \text{Mdol}$$

3. Direct Cost:

$$DC := C_L + C_M$$

$$DC = 11.837 \text{Mdol}$$

F. Overhead: Enter Overhead Rate: **ovhd := 1.5**

$$IC := DC \cdot \text{ovhd}$$

$$IC = 17.756 \text{Mdol}$$

G. Profit: Enter Profit Rate: **profit := .11**

$$\text{Profit} := \text{profit} \cdot (IC + DC)$$

$$\text{Profit} = 3.255 \text{Mdol}$$

H. Total Construction Cost: (BCC)

$$C_{BCC} := (1 + \text{profit}) \cdot (DC + IC)$$

$$C_{BCC} = 32.849 \text{Mdol}$$

SSGN Modifications: (Only pertinent portions of the model shown)

Approximate Weights: **Overall Weight of ADDS = 58.518 Itons (APP G)**

$W_1 := 0\text{ton}$	Hull
$W_2 := 0\text{ton}$	Propulsion
$W_3 := .75\text{ton}$	Electrical
$W_4 := 0\text{ton}$	Command & Control
$W_5 := 1.2\text{ton}$	Auxillaries
$W_6 := 0\text{ton}$	Outfitting
$W_7 := 0\text{ton}$	Armament

Establish Cost units: $\text{Bdol} := 1000\text{Mdol}$ $\text{Kdol} := \frac{\text{Mdol}}{1000}$ $\text{dol} := \frac{\text{Kdol}}{1000}$

****Calculations performed are the same as in the ADDS model.**

E. Direct Costs:

1. Labor Cost:

$$C_L := \sum_{i=1}^9 C_{L_i} \qquad C_L = 0.796\text{Mdol}$$

2. Material Cost:

$$C_M := \sum_{i=1}^9 C_{M_i} \qquad C_M = 0.279\text{Mdol}$$

3. Direct Cost:

$$\text{DC} := 3C_L + C_M \qquad \text{*Labor increased for on hull mods.} \qquad \text{DC} = 2.667\text{Mdol}$$

F. Overhead: Enter Overhead Rate: $\text{ovhd} := 1.5$

$$\text{IC} := \text{DC} \cdot \text{ovhd} \qquad \text{IC} = 4\text{Mdol}$$

G. Profit: Enter Profit Rate: $\text{profit} := .11$

$$\text{Profit} := \text{profit} \cdot (\text{IC} + \text{DC}) \qquad \text{Profit} = 0.733\text{Mdol}$$

H. Total Construction Cost: (BCC)

$$C_{\text{BCC}} := (1 + \text{profit}) \cdot (\text{DC} + \text{IC}) \qquad C_{\text{BCC}} = 7.401\text{Mdol}$$

ALVIN Modifications: (Only pertinent portions of the model shown)

Approximate Weights: **Overall Weight of ADDS = 58.518 Itons (APP G)**

$W_1 := .5\text{ton}$	Hull
$W_2 := 0\text{ton}$	Propulsion
$W_3 := .1\text{ton}$	Electrical
$W_4 := 0\text{ton}$	Command & Control
$W_5 := .1\text{ton}$	Auxillaries
$W_6 := 0\text{ton}$	Outfitting
$W_7 := 0\text{ton}$	Armament

Establish Cost units: $\text{Bdol} := 1000\text{Mdol}$ $\text{Kdol} := \frac{\text{Mdol}}{1000}$ $\text{dol} := \frac{\text{Kdol}}{1000}$

****Calculations performed are the same as in the ADDS model.**

E. Direct Costs:

1. Labor Cost:

$$C_L := \sum_{i=1}^9 C_{L_i} \qquad C_L = 0.152\text{Mdol}$$

2. Material Cost:

$$C_M := \sum_{i=1}^9 C_{M_i} \qquad C_M = 0.034\text{Mdol}$$

3. Direct Cost:

$$\text{DC} := C_L + C_M \qquad \text{DC} = 0.186\text{Mdol}$$

F. Overhead: Enter Overhead Rate: $\text{ovhd} := 1.5$

$$\text{IC} := \text{DC} \cdot \text{ovhd} \qquad \text{IC} = 0.279\text{Mdol}$$

G. Profit: Enter Profit Rate: $\text{profit} := .11$

$$\text{Profit} := \text{profit} \cdot (\text{IC} + \text{DC}) \qquad \text{Profit} = 0.051\text{Mdol}$$

H. Total Modification Cost: (MC):

$$C_{MC} := (1 + \text{profit}) \cdot (\text{DC} + \text{IC}) \qquad C_{MC} = 0.516\text{Mdol}$$