

# RESIDENTIAL CALIFORNIA ADOBE : MUD FORM

by  
Diana Leigh Daymond  
B.A., University of California  
Berkeley, California  
June, 1980

SUBMITTED TO THE DEPARTMENT OF ARCHITECTURE IN PARTIAL FULFILLMENT OF THE  
REQUIREMENTS OF THE DEGREE OF MASTER OF ARCHITECTURE AT  
MASSACHUSETTS INSTITUTE OF TECHNOLOGY

FEBRUARY 1985

© Diana Leigh Daymond 1984

The author hereby grants to M.I.T. permission to reproduce and to distribute  
publicly copies of this thesis document in whole or in part.

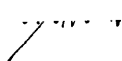
Signature of author . . . . .  Diana Daymond, Department of Architecture, December 21, 1984

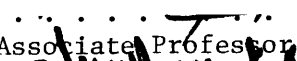
Certified by . . . . .  Fernando Domeyko, Associate Professor of Architecture, Thesis Supervisor

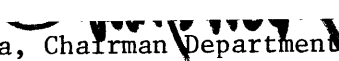
Accepted by . . . . .  Shun Kanda, Chairman Departmental Committee on Graduate Student



MASSACHUSETTS INSTITUTE  
OF TECHNOLOGY

FEB 22 1985

Rotch

LIBRARIES





"The house after all is only the shell and the real interest must come from those who are to live in it. If this is done carefully and with earnestness, it will give the inmates a sense of satisfaction and rest and will have the same power over the mind as music or poetry or any healthy activity in any kind of human experience".

Bernard Maybeck  
1908







"That's technology for you—prestressed adobe!"









# ABSTRACT

RESIDENTIAL CALIFORNIA ADOBE: MUD FORM

by  
Diana Leigh Daymond

Submitted to the Department of Architecture on December 21, 1984 in partial fulfillment of the requirements for the Degree of Master of Architecture.

Northern California has a rich tradition of adobe architecture. Formed with earth, defined by site, climate and use, the adobe structures exemplify a building methodology in harmony with nature and the lifestyle of its inhabitants. The use of adobe as a construction material is currently gaining in popularity. This thesis seeks to understand its historic form and provide a framework for incorporating these principals in contemporary design.

The foundation of this framework is built upon a detailed analysis of historic, non-ecclesiastical adobe buildings. Through observation and analysis of measured drawings, the principals which guided early builders are delineated. The framework is then expanded to suggest sensitive design innovations in consideration of modern technological opportunities and contemporary social requirements.

The framework generated from the synthesis of the historic analysis and design exploration is used and tested in the design of an attached housing project sited in Cotati, California. It is concluded that the historic principals are well suited to contemporary adobe construction. Indeed, they are important lessons worth incorporating in design solutions using any material.

Thesis Supervisor: Fernando Domeyko  
Title: Associate Professor of Architecture





## ACKNOWLEDGMENTS

As a personal exploration, this thesis represents the lifelong love and influence of those dearest to me... my family. In endless appreciation, I offer here:

My exuberant thanks to Dad for:

- ♥ clandestine explorations of the Oakland MUSEUM.
- ♥ Saturday afternoons of drawing with big marking pens on the back of old blueprints.
- ♥ Hot Sonoma french bread munched down on visits to the Petaluma Adobe.

Just the BIGGEST hug to MOM for...

- ♥ Fighting lifes tough battles... and winning! Thereby igniting my desire to set high goals and showing me the courage to realize those goals.

14 1/2 pieces of ♥ to Donaldina for...

- ♥ Picnic baskets of silver, scallops and support during charrettes
- ♥ Reassurance and encouragement when times were tough.
- ♥ Tickles, laughter and love which I know is always there.



# TABLE OF CONTENTS

ABSTRACT . . . . .	9
ACKNOWLEDGMENTS . . . . .	11
TABLE OF CONTENTS . . . . .	12
INTRODUCTION . . . . .	15
RELATIONSHIP BETWEEN BUILDING AND SITE . . . . .	23
Solar Orientation . . . . .	24
Climatic Factors . . . . .	26
Terrain . . . . .	28
Landscape Elements . . . . .	30
Urban Setting . . . . .	31
PROJECT COMPOSITION . . . . .	33
Building Complex . . . . .	34
Connected Buildings . . . . .	36
Positive Outdoor Space . . . . .	39
Manipulate the Climate . . . . .	42
Massing . . . . .	43
Roof Lines . . . . .	44
Presentable Facades . . . . .	47
INTERIOR LAYOUT . . . . .	51
Rectangle Plan . . . . .	52
Courtyard Plan . . . . .	54
Center Hall Plan . . . . .	56
Privacy Hierarchy . . . . .	58
Sun Definition of Use . . . . .	61
Exterior Access . . . . .	63
Separate Structures . . . . .	66



INTERIOR-EXTERIOR INTEGRATION . . . . .	67
Hierarchy of Outdoor Space . . . . .	68
Corredor . . . . .	74
Courtyard . . . . .	76
Garden Entrance . . . . .	80
BUILDING EDGE DEFINITION . . . . .	83
Foundation . . . . .	84
Garden Wall . . . . .	86
Doors . . . . .	88
Windows . . . . .	91
Balconies . . . . .	93
INTERIOR DEFINITION . . . . .	97
Thick Walls . . . . .	98
Flooring . . . . .	100
Strategic Wood Location . . . . .	101
Kitchen and Bathroom . . . . .	103
EXTERIOR DEFINITION . . . . .	105
Continuous Flooring . . . . .	106
Soft Space . . . . .	108
Filtered Light . . . . .	110
Colors . . . . .	112
DESIGN PROJECT . . . . .	113
Problem Statement . . . . .	114
Site Analysis . . . . .	118
Site Plan . . . . .	124
Unit Designs . . . . .	140
Unit Clusters . . . . .	161
CONCLUSION . . . . .	179
BIBLIOGRAPHY . . . . .	181





## INTRODUCTION

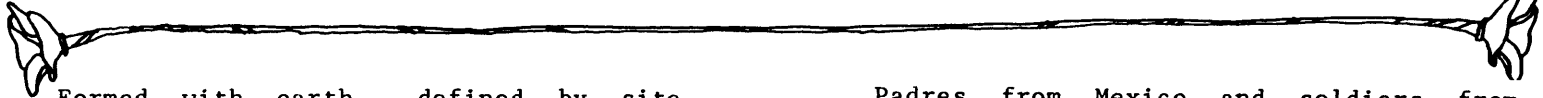

Formed with earth, defined by site, climate and lifestyle, California's adobes exude a spirit of absolute sincerity and intimacy in their interaction with nature. Designed to meet the simple needs of early California settlers, their rugged textures and unrefined atmosphere are perfectly suited to California's robust outdoor lifestyle. Built of mud bricks and articulated with redwood, they form a distinct built typology which can suggest and give guidance to the creation of a framework for designing contemporary buildings. Such a framework would take advantage of California's mild climate, be sensitive to its dynamic topography and facilitate the vital outdoor lifestyle of its residents.

Padres from Mexico and soldiers from Spain were responsible for bringing adobe construction to California during the late eighteenth century. Beginning in 1769, these settlers founded a series of missions, pueblos, and presidios at points along the California coast between San Diego and Sonoma. These buildings conformed both in appearance and in the materials used, to the architecture of their mother country - Spain. Ranging in size and design from impressive Missions; such as that at Carmel and Santa Barbara, to tiny, one-room ranch houses, all of the buildings have in common their thick, sturdy adobe walls and an integration in plan and siting with their surrounding landscape.





DON JOSÉ DE JESUS VALLEJO ADOBE





The all but universal use of adobe as a building material throughout the colonization period sprang from a variety of circumstances. First, it was a construction methodology familiar to the friars and military authorities, as it had long been used in both Spain and Mexico. Second, the mild climate of the region; long dry summers with only winter rain, made adobe construction practical. And if the adobe were properly cared for, it would be long lasting. Finally, adobe construction was a technology easily taught by the padres to the indian converts from whose labor emerged the mission structures.

The adobes erected during this period were of two general types. In the customary

procedure, the heavy black soil or clay of the region was mixed with whatever binders were available at the site. These might be reeds, grass, twigs, or shells from the beach. This mixture was formed into bricks, generally 11" x 22" inches in size. These bricks were then laid one upon the other, with a thin layer of mud between each row, to form a wall. The wall was covered on the outside with a coating of plaster to protect it from the elements. The second process consisted of employing building forms similar to those used in present - day concrete construction. The walls were made by filling the space between forms with dampened earth. The earth was solidly tamped down, and after the forms were



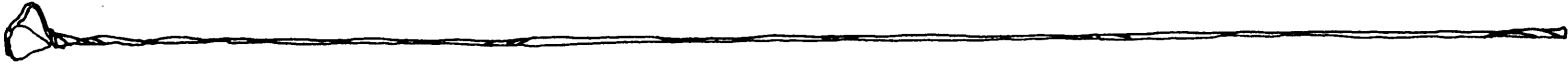

removed, a protective coating was applied to the outer surface.

These buildings would last indefinitely provided certain precautionary rules were observed. One was that the earthen walls be protected from the elements by an outer coating of a water-resistant substance, commonly a thin layer of sand with which lime was mixed. After the walls had been coated, they were whitewashed. It was also necessary that the roof be kept in repair and that the eaves project far enough beyond the building so that the bulk of the rain water fell clear of the walls.

In the early nineteenth century families began to settle in California. These settlers

began building modest adobe dwellings clustered in newly founded pueblos or adjoining presidios. These dwellings were generally one-story, rectangular or "L" shaped. They were typically composed of a series of rooms which opened directly into each other. The roof overhangs of these dwellings were extended to form a "corredor" under which activity could extend, protected from rain or the harsh afternoon sun. Adjoining all adobe dwellings was a patio or walled-in area where most family living took place. Both patios and corredores were sited to take full advantage of the sun. Indeed, these areas become the center of all household activity.



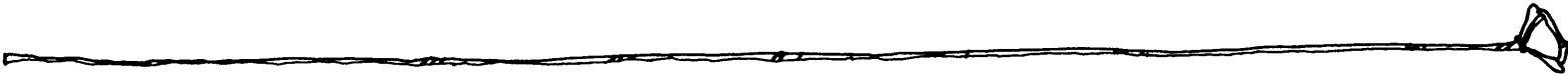

Prior to 1835, adobe construction was firmly grounded in the Spanish tradition. But in this year, an immigrant from New England - Thomas Larkin constructed an adobe house whose design was primarily based in the New England tradition while incorporating some elements of Carolina plantation architecture. From the New England tradition came the floor plan with a central interior hall and staircase. While the hipped shake roof and surrounding verandahs; built to protect the walls from water erosion, were based in the Carolina plantation tradition. The Larkin house established a new style of California architecture - Monterey Colonial.

Subsequent decades saw the refinement and integration of both the Spanish and Monterey Colonial design styles. Together with the increased use of wood on the building exterior, a building typology unique to California evolved. This rich architectural style was grounded in the use of native materials and a desire to integrate living with the outdoors. Its principals are as relevant today as they were in the eighteenth century.

Enthusiasm and nostalgia for the colonial dwellings must be tempered with an understanding of the lack of comfort they offered their residents. Of course, they were without most of the modern amenities we take



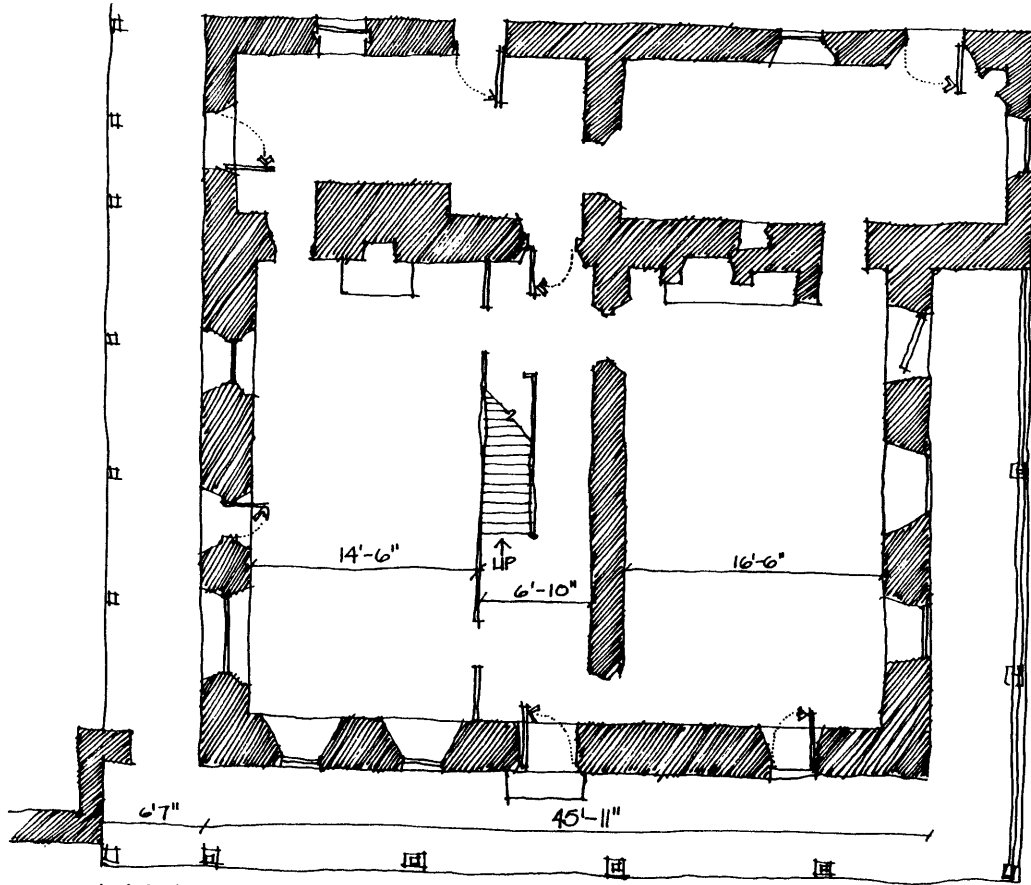
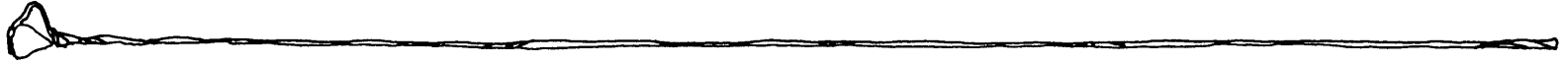

LARKIN HOUSE # MONTEREY



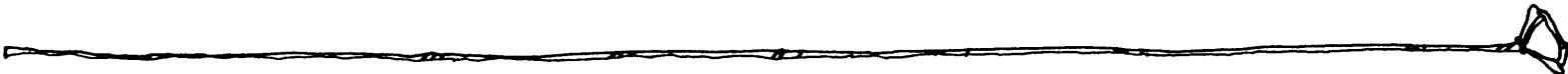

for granted today. Additionally, modern technology places demands on construction which could not be met in strict historic reproductions, such as reinforcement, electrical, and plumbing requirements. But modern technology can offer compromises. It can be used to overcome limitations of traditional adobe design such as poor interior lighting, and water solubility.

The consolidation of historic adobe design principals with modern technology and design innovation could offer a framework

detailing design principals relevant for contemporary construction. In an era when the golden hills of California are being covered with replicas of English tudors and New England salt boxes, the design tradition sensitive to the robust California lifestyle, dynamic landscape, and mild climate needs to be re-established. This tradition should be tempered with contemporary considerations. Yet, it s main functions will be to reincorporate native materials into construction, integrate buildings into the environment, and to provide an ideal built environment in which residents can take full advantage of the living qualities California has to offer.





## RELATIONSHIP BETWEEN BUILDING AND SITE

The construction of colonial adobes was the beginning of rich architectural tradition whereby consideration of a buildings' context suggested design solutions which would take full advantage of a sites' positive features. At the turn of this century, this tradition continued. California architects in the craftsman tradition took pride in considering the surrounding context and doing everything possible to preserve the landscape. They believed that a building should not stand out from the landscape but fit into it.

Initial siting of a building or complex is a crucial stage in the design process. Decisions arrived at during this stage will

inevitably shape all future design decisions, encouraging their success or doom them to failure. Before one can start to design the individual building, they must have a thorough understanding of all factors affecting the site. How does the sun travel across the site? From where does the wind blow? How does water flow? Is there a lovely vista to be taken advantage of? Which landscape elements, such as trees, should be preserved? How does the site relate to the larger landscape? How and where do vehicles gain access? Only when all these questions are answered, and the consequences of the answers understood, is the designer ready to place the building on the site.



# Solar Orientation

← NORTH

40 TH. SCALE

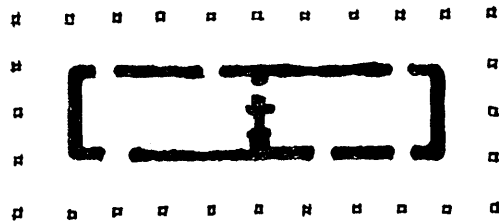

CARILLO ADOBE  
SANTA ROSA

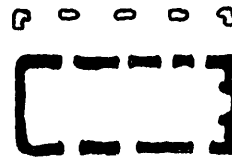

CONZAGA ADOBE  
LOS BAÑOS

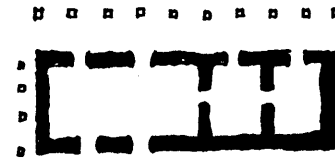

SHERWOOD RANCH  
SALINAS

By and large, spaces cast in shadow are devoid of activity, while those bathed in sunshine are alive.

Solar orientation was the single most important factor determining the siting of colonial adobes. Except in towns, where established street patterns would dictate orientation, houses were oriented north -

south, allowing sun light to enter all rooms during the day. Patios were placed to the south or east, in order to maximum access to morning light. The north elevation, always cast in shadow, had minimal openings. While west light was filtered or minimized in order to diminish the effects of the harsh afternoon sun.



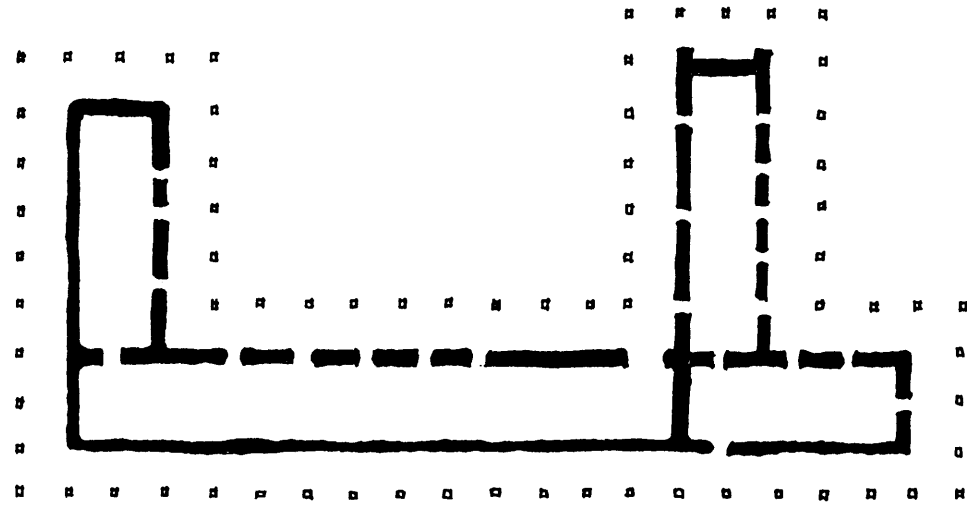
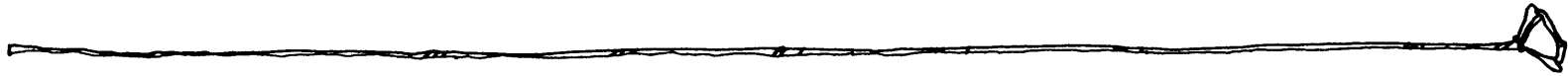

← NORTH  
PETALLIMA DOBE

40 TH. SCALE

Today it remains ideal to place outdoor spaces where they will receive maximum sunlight. Harsh light should be filtered. Additionally, the building itself should be placed on the northern edge of the site, maximizing southern exposure.



## Climatic Factors

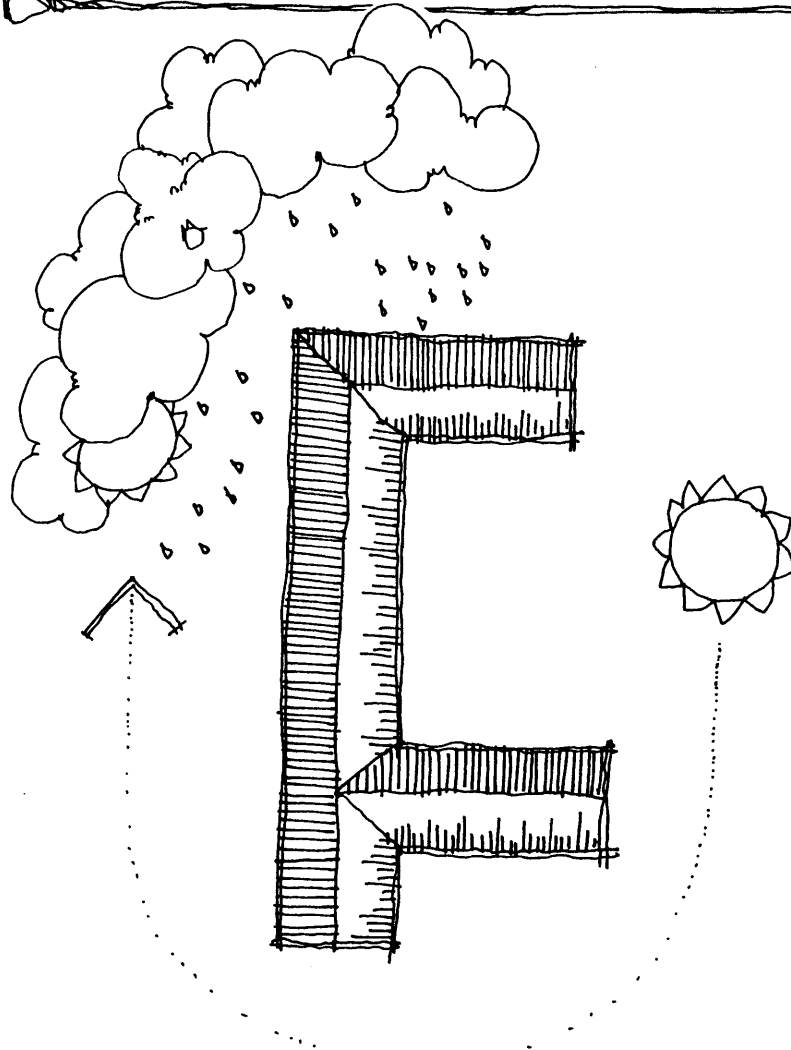

Wind can effect comfort as much as sunlight. A summer breeze cools while a wind causes discomfort. Thus, cross ventilation in summer is to be encouraged while a winter wind is blocked from entering living spaces. On an urban lot, wind control is not a large factor since its effect is minimized through deflection off of neighboring buildings. But on a rural site, prevailing winds need to be taken into account. Outdoor living spaces should be shielded by the form of the building or landscape elements such as garden walls, trees or hedges.

PETALUMA ADOBE # SONOMA





With wind, often comes rain. Adobe walls are very vulnerable to water, requiring the designer to sensitive to rain. Thus, on building edges facing the rain, roof overhangs must be particularly deep in order to preserve and maintain the adobe wall.

In Northern California, fog is an everpresent climatic element. The fog rolls off the ocean, to the west. It cools the evening air to make sleeping comfortable. In the morning, it rolls out, over the ocean. Sometimes however, the fog is trapped at the bottom of valley's, not to dissipate until late morning or early afternoon. Because of fogs settling nature, it is best to build up off the edge of the valley floor.



# Terrain

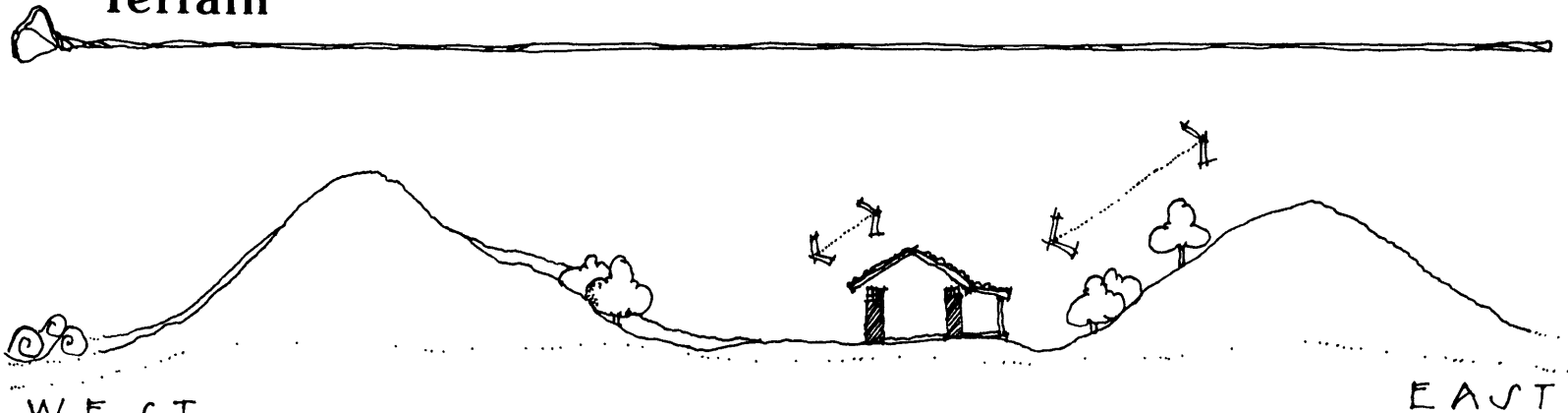

## WEST LANDSCAPE ELEMENTS \* TERRAIN

California topography is composed of a sequence of mountain and hill ranges running north to south, in parallel with one another. Resulting from this formation are a series of valleys which also run from north to south, between the ranges. Thus, the predominant direction of the landscape is north - south. In the wine country, water runs from the north to San Francisco Bay, in the south. Roads travel along valley floors with only a rare

twisting path crossing the high hills. Historically, even the early adobes were oriented north - south, in concordance with the orientation of the landscape. And their roofs angled up in the same direction as the hills.

With in a site, it is best to place an adobe building on high ground, safe from water drainage. This location will protect the earthen walls from water erosion.



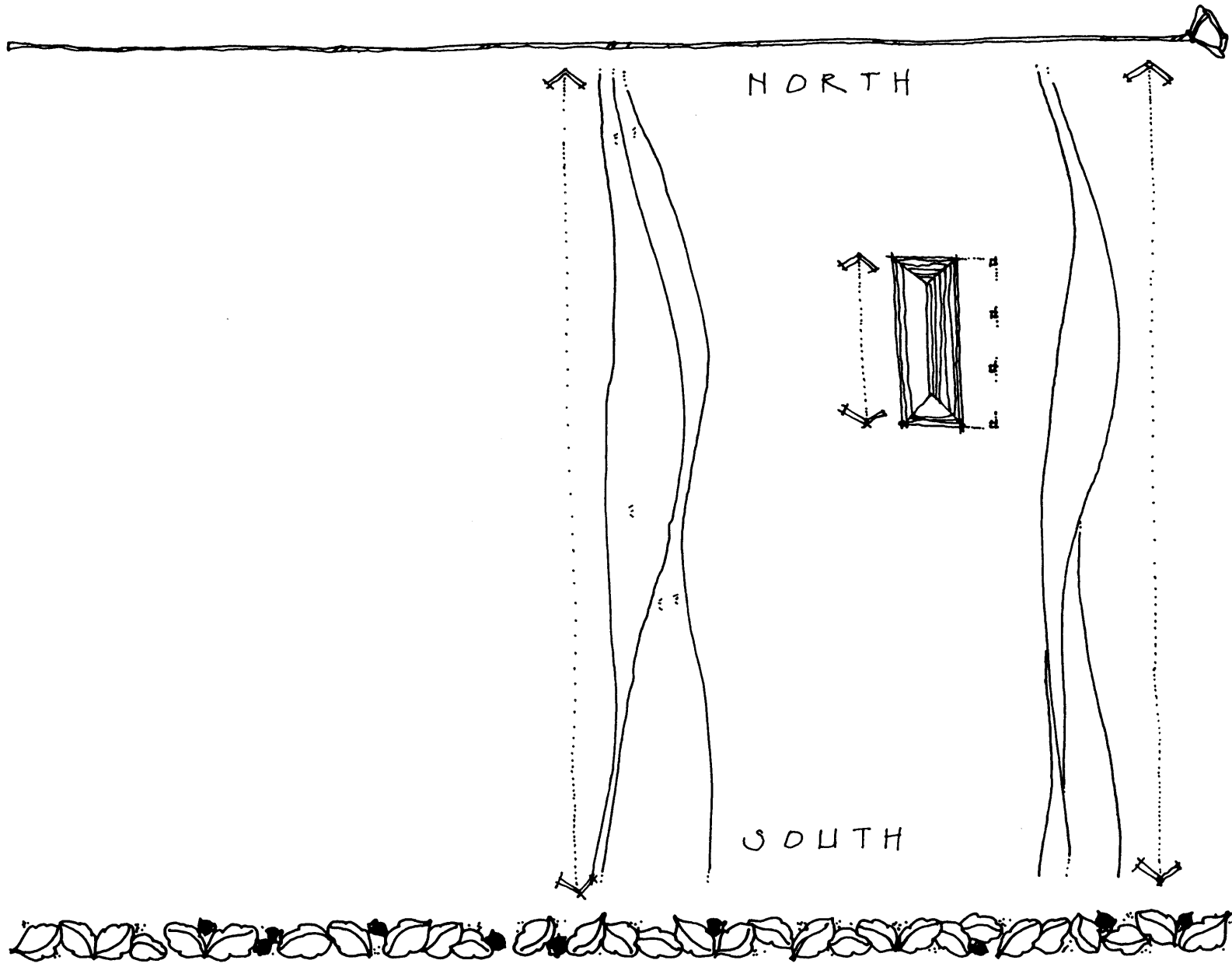

# Landscape Elements

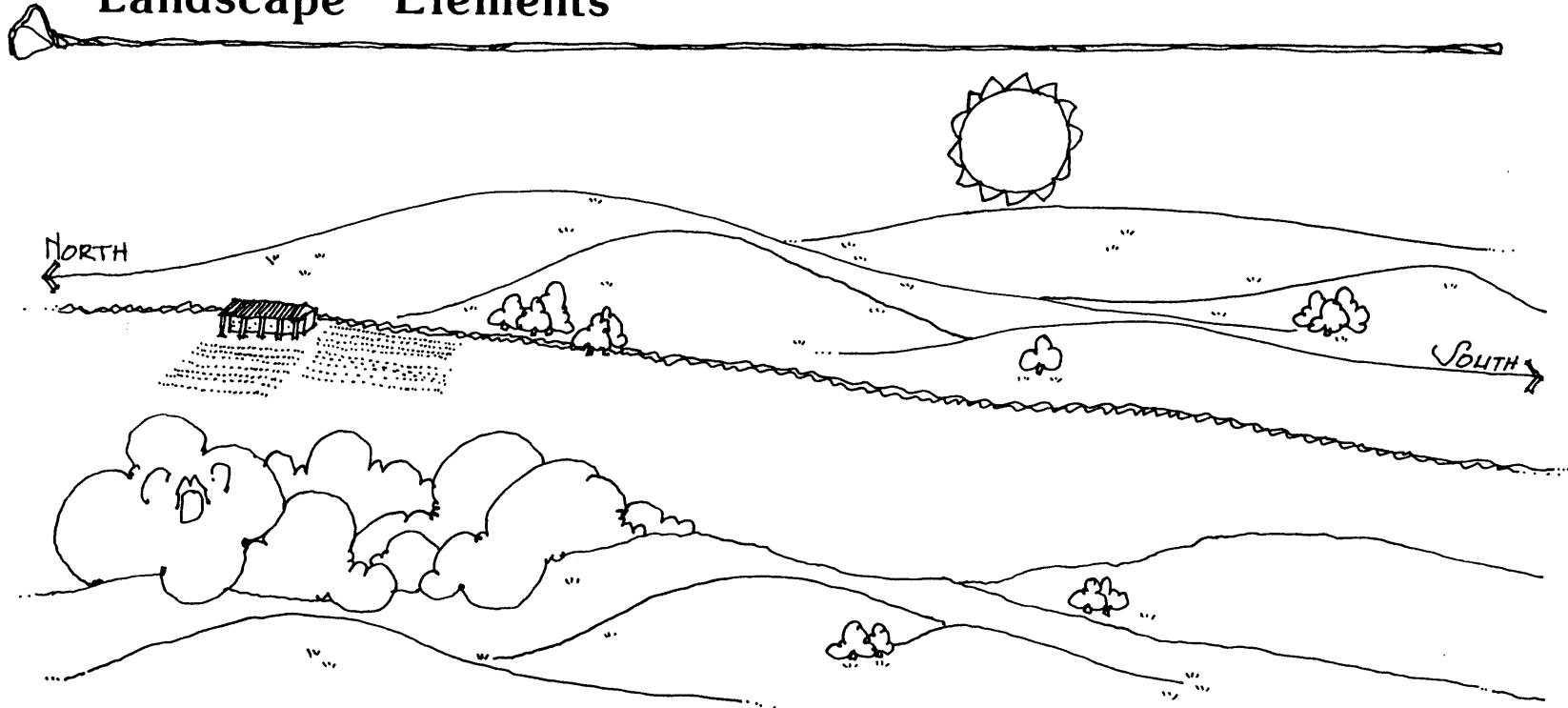

~~~~~ PACIFIC OCEAN ~~~~~

Many sites are blessed with beautiful individual landscape elements which should be preserved and taken advantage of at all costs. In Northern California a majestic oak or rock cropping are elements which should be designed

around rather than bulldozed to ease construction. A lovely vista should be pointed out and become visible from a special place in the building.



## Urban Setting

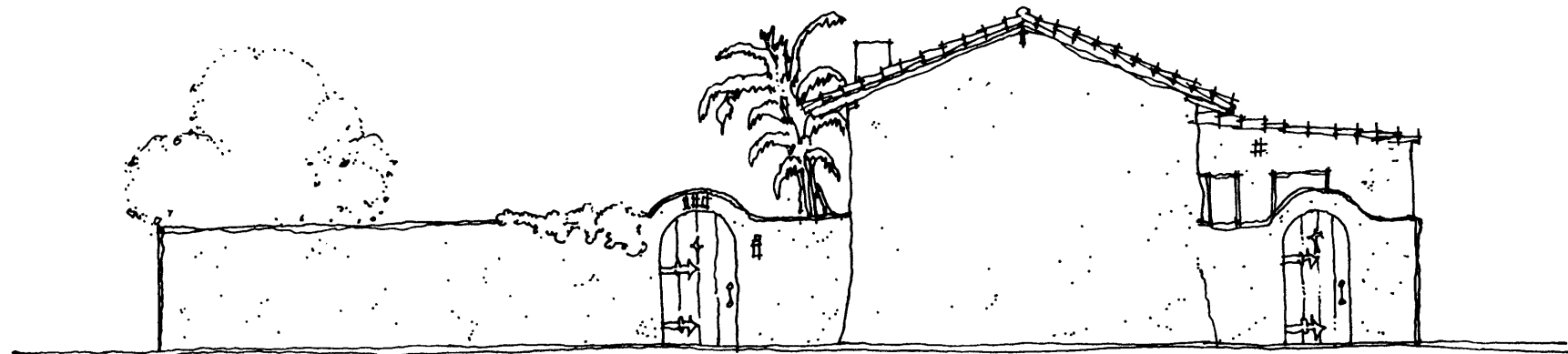

EL CUARTEL # SANTA BARBARA

It is obvious how the preceding principals are particularly relevant to a rural site. But in an urban setting, on a tight, defined site, the designer needs to take particular care in preserving and encouraging district landscape elements which are all too rare.

Different than the rural site, the urban site is often burdened with unique problems such as a lack of privacy and usable outdoor space. Historically, these inadequacies have been dealt with using two different solutions. The first, is a townhouse design common through out Spanish America. The building



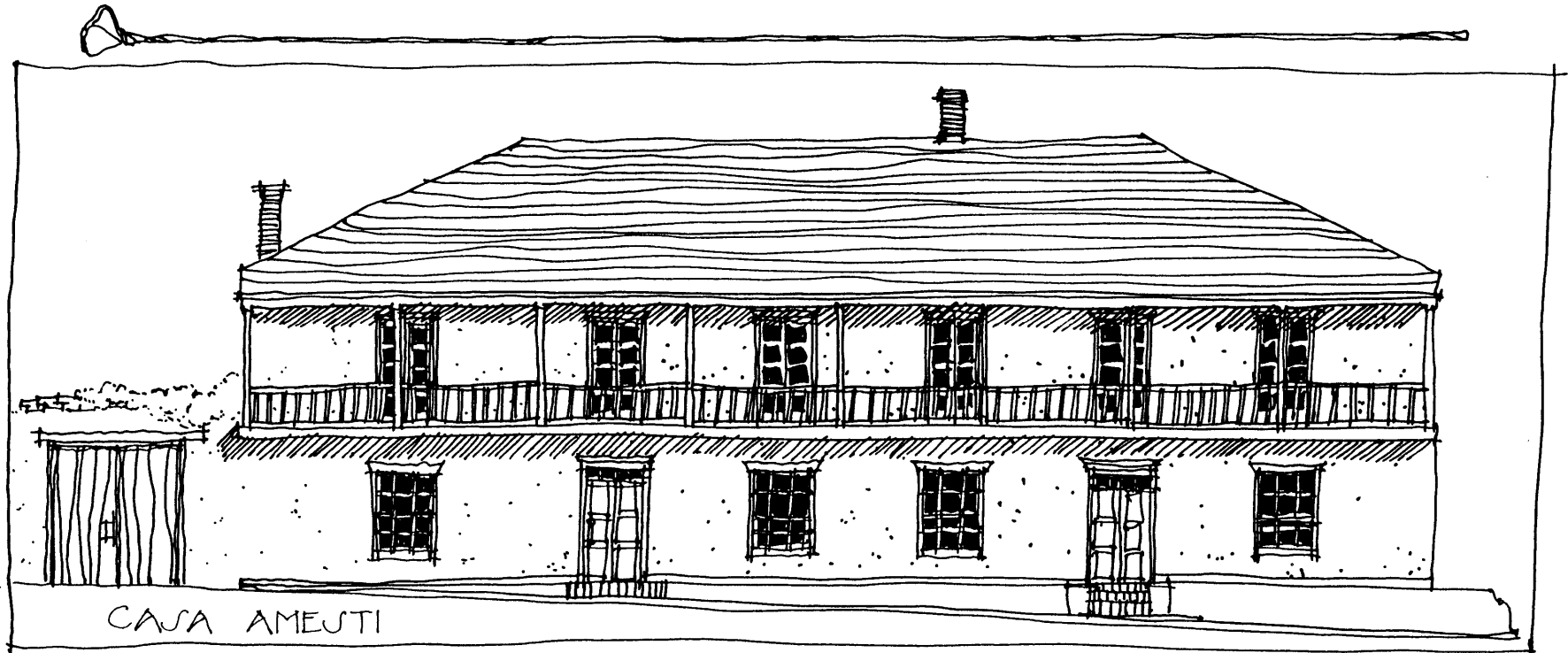

CASA AMESTI

presents to the street a severe blank wall opened only by grill guarded windows or a garden gate. Beyond the gate is a quiet garden surrounded by walls which serves as the entry court and private outdoor space. The second design presents to the street a long

covered corredor which serves as the transition zone between the private house and the public street. Larger homes may be in the plan of an "L" or "U", with the resulting back courtyard serving as the residents private outdoor area.



## PROJECT COMPOSITION

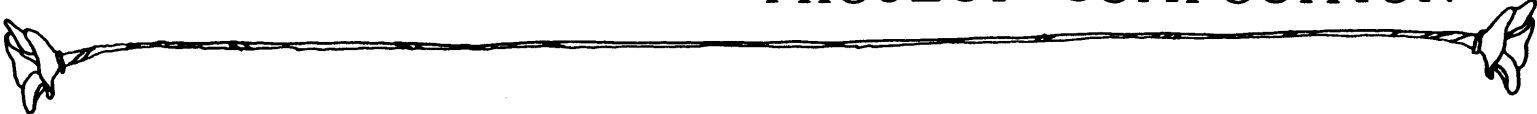

Much of the charm of a colonial adobe is derived from its resemblance to a miniature compound, or village. In earlier times, a household had to be completely self supporting. This necessity required that a variety of tasks be completed within the household. Appropriate structures and space were needed to carry out these tasks and a community of people formed which extended the household to include many more people than family members.

This dynamic household developed over time and would transform an originally modest dwelling. Multiple buildings would be added and landscape elements used to connect and

interrelate the growing community. Thus, an historic adobe building rarely existed as a single element. It incorporated the landscape and attached itself to adjacent structures, forming a building complex.



## Building Complex

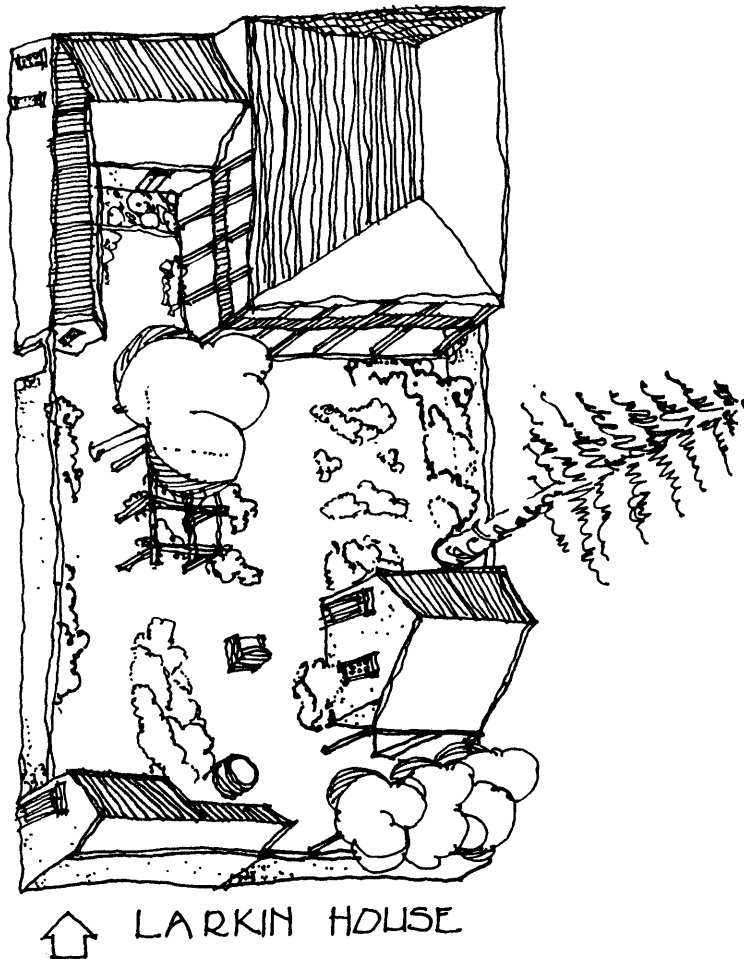

Historically, architectural composition was a factor of time and an additive process. The resulting form, the building complex, reflected a thoughtful, human scale, derived from a variety of demands.

Parallel thinking can suggest that contemporary, monolithic buildings are a result of one shot construction. It is not intended that these buildings be transformed. Additionally, their singular construction ignores the variety of activities which may take place within it thus denying the scale of the individual or sub-group.

A contemporary lifestyle, as much as that of the early California settlers, is composed





of a variety of activities. These activities demand spaces providing a variety of privacy levels and outdoor access. Consequently, a designer should strive to create a building complex. Through the building form and the addition of landscape elements, a hierarchy of spaces should be defined for different uses. At the residential scale, small buildings for vehicles or storage will expand a house into a building complex.

An additive construction process might also be an economic solution in building affordable housing. If money is insufficient, residents could plan the entire project but build first only the parts which are

absolutely necessary. As money becomes available, the rest can be added, forming a harmonious whole.



## Connected Buildings

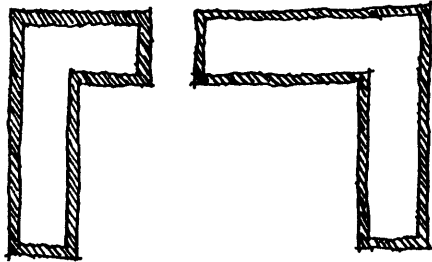

TWO  
SEPARATE  
BUILDINGS

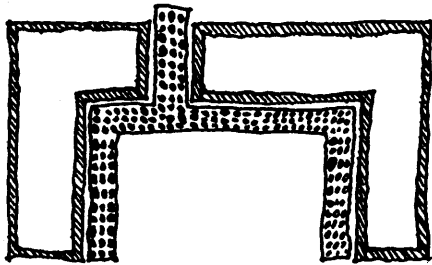

HORIZONTAL  
CONNECTION:  
FLOOR AND  
CORREDOR

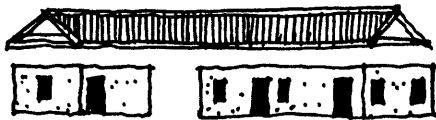

VERTICAL  
CONNECTION:  
ROOF

CASA DE LA GUERRA

In order to form a building complex from a collection of buildings, it is necessary to connect the buildings. The buildings can be literally connected to each other or through the addition of a third built element.

In plan, adobe buildings are most often connected with the addition of a corridor or verandah. The corridor is attached between buildings thus forming a common, protected circulation link. The garden wall is a second architectural element used for connection. The wall not only links outlying buildings but encloses the space between them.

On the vertical level, a common roof might join multiple buildings to become one. While horizontal continuity can result from



↑ LARKIN HOUSE

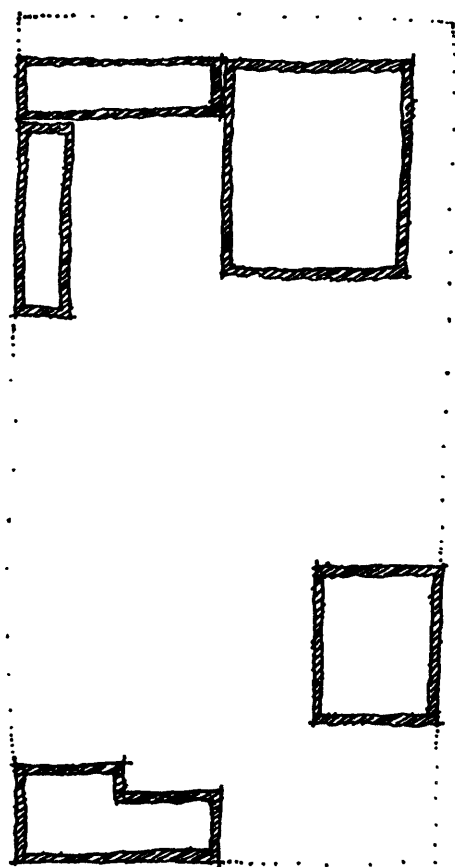

BUILDINGS ONLY

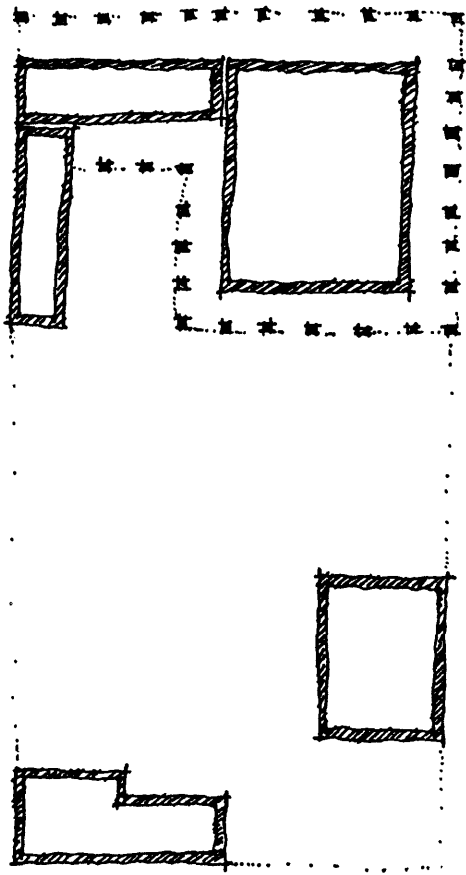

BUILDINGS + CORREDORES

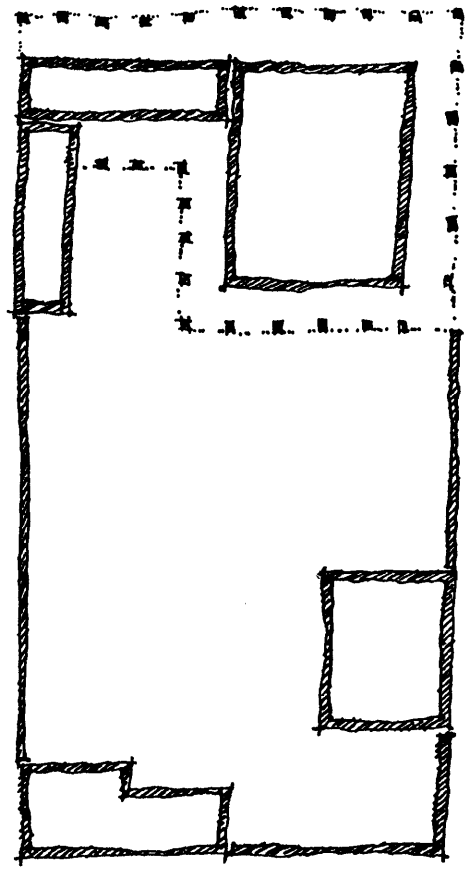

BUILDINGS + CORREDORES  
+ GARDEN WALL



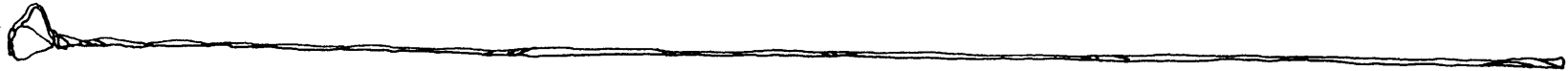

the addition of a common flooring material between two different areas.

The beauty of the connective process is that when a new element is used to join separate structures, a new kind of space inevitably results.



## Positive Outdoor Space

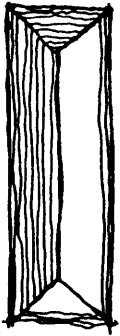

SHERWOOD  
RANCH

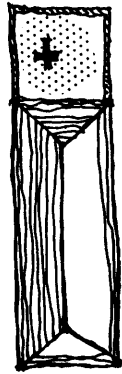

CASA AMESTI

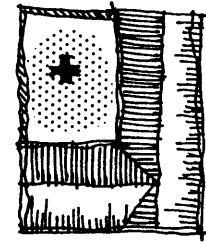
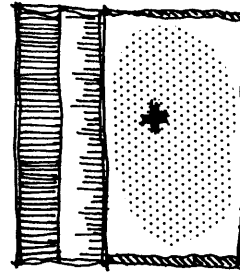

EL CARTEL

One of the most positive results of the connective process or a sensitive building plan is the definition and enclosure of outdoor space. If formed appropriately, this space will take on the characteristics of positive outdoor space. Positive outdoor space is defined as a convex space which in

itself feels enclosing. It is usually a protected space in which sun and wind are under control.

The first element one should manipulate to create positive outdoor space is the building itself. The building can be sited to take full advantage of the sun while blocking



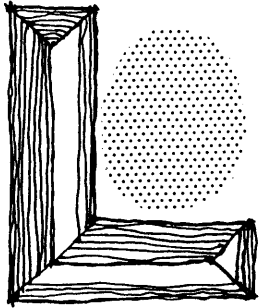
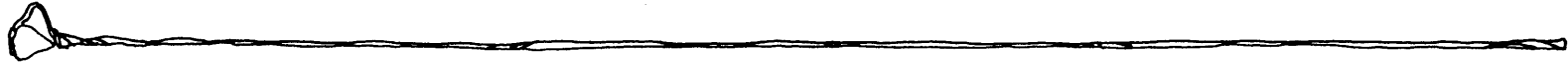

MIRANDA HOUSE  
SANTA BARBARA

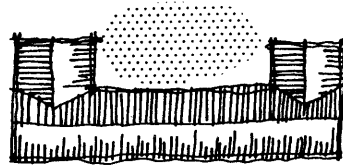

VHAY HOUSE  
SANTA BARBARA

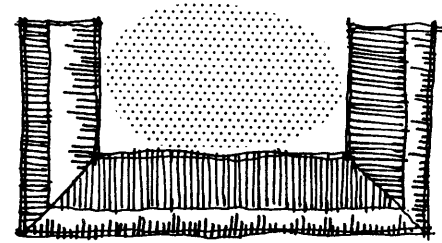

CASA DE LA GUERRA

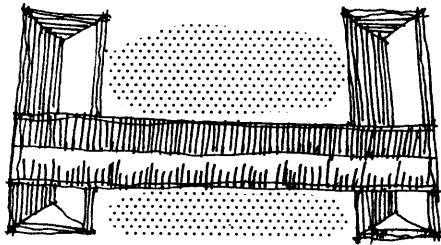

DANA HOUSE  
SAN LUIS OBISPO

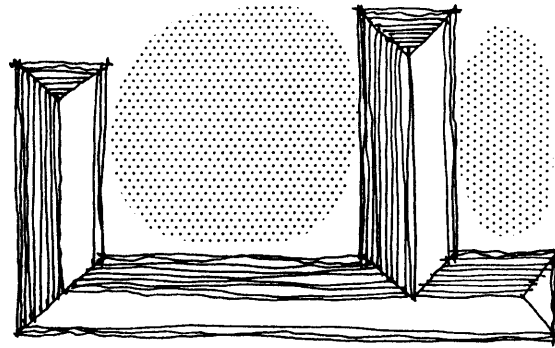

PETALLUMA ADOBE

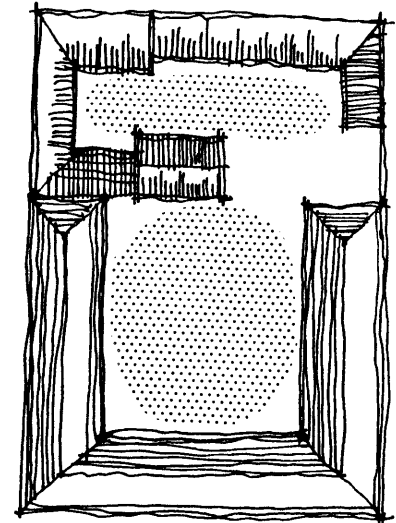

LA CASA DEL RANCHO  
SAN DIEGO



---

unfavorable winds. Its plan can gesture towards the landscape, embracing and forming sub-outdoor space adjacent to it. Through the use of walls, the building can claim more outdoor space when a rambling building is inappropriate.

The creation of positive, protected outdoor space, adjacent to the building, will maximize the amount of living space available to residents. Living space is that combination of indoor and outdoor space which offers privacy and protection from the elements. The mild California climate, and outdoor lifestyle of its residents makes full utilization of outdoor living space of paramount importance.

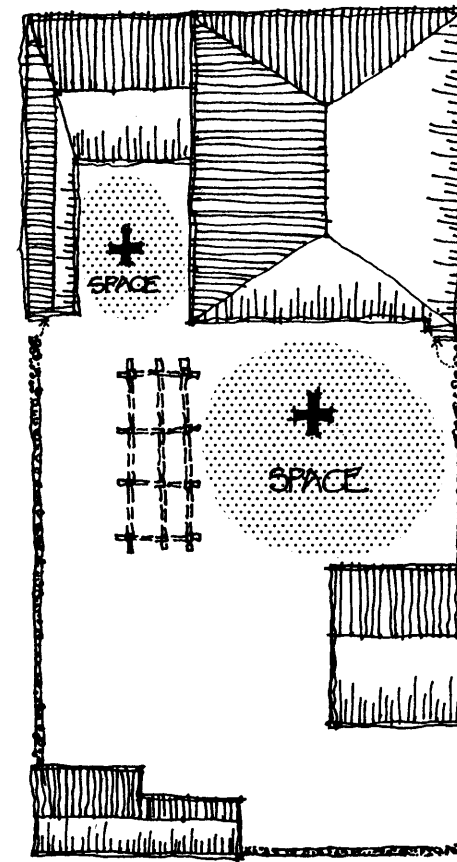

↑ LARKIN HOUSE



## Manipulate the Climate

---

To create protected outdoor living space the weather must be manipulated. Positive outdoor space will benefit from the addition of landscape elements which modify the weather making these spaces more inviting.

The garden wall defines space and then prevents harsh winds from entering the space. Sensitive planted trees will have the same effect. Too much sun can be modified through the addition of trellis's, shade trees, non-glare surfaces, water and cool colors. While outdoor spaces with too little sun can be enhanced by reflecting walls and paving which captures light that does enter.



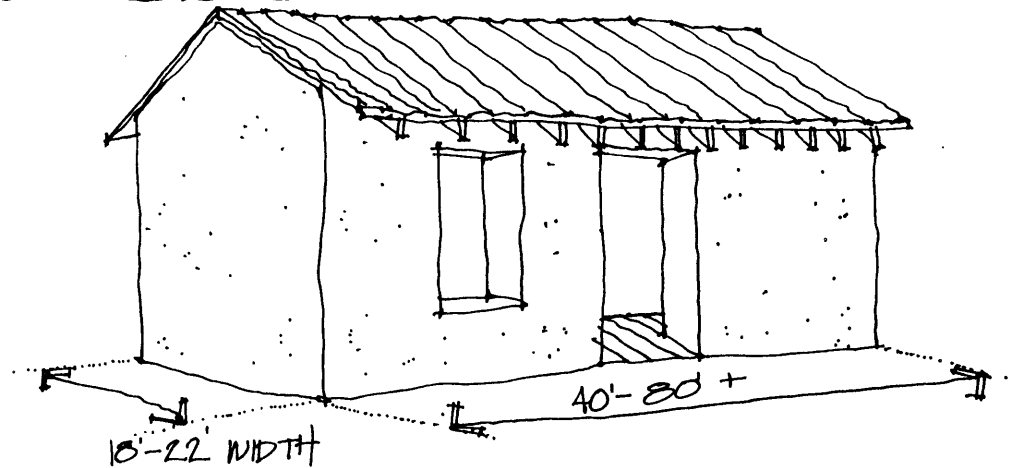

## MASSING PROTOTYPE

A key element in the successful composition of a building complex is the massing of its elements. General massing principals suggest that a building complex needs a center which may be a taller building or an area of higher density. This area should house the most important public function of the complex.

When using adobe, the material itself

will determine much of the massing dimensions and configuration. Individual adobe buildings are rarely more than 20' wide or more than two stories tall. Their length can vary considerably, but a wall extension or job is needed after approximately 20'. When oriented from north to south, their massing mimics the long rolling hills of the California landscape.



## Roof Lines

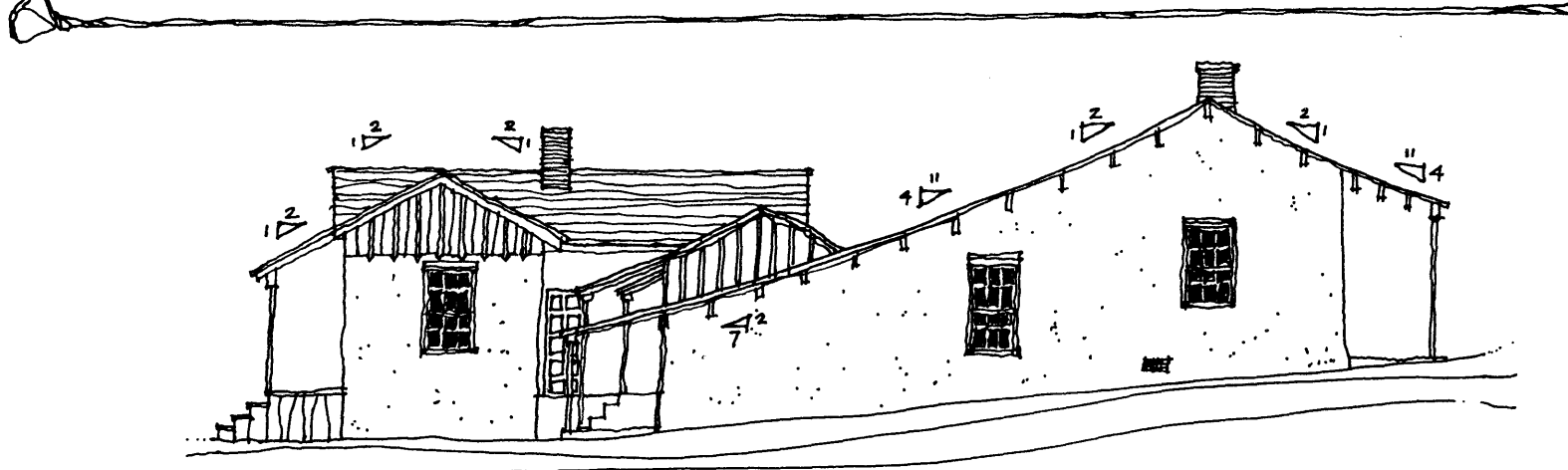

CARSON HOUSE # ALMADEN

Intrinsic in massing composition are roof lines. The fall of the roofs can pull together disparate elements or call out those more important.

Adobe structures are admired for their graceful, flowing rooflines which emphasize

the linearity of the adobe structure and harmonize the structure within the landscape. Most adobe roofs are framed in redwood, and in Northern California, covered with redwood shingles. They are gently pitched, flattening out over corridors. Adobes designed in the



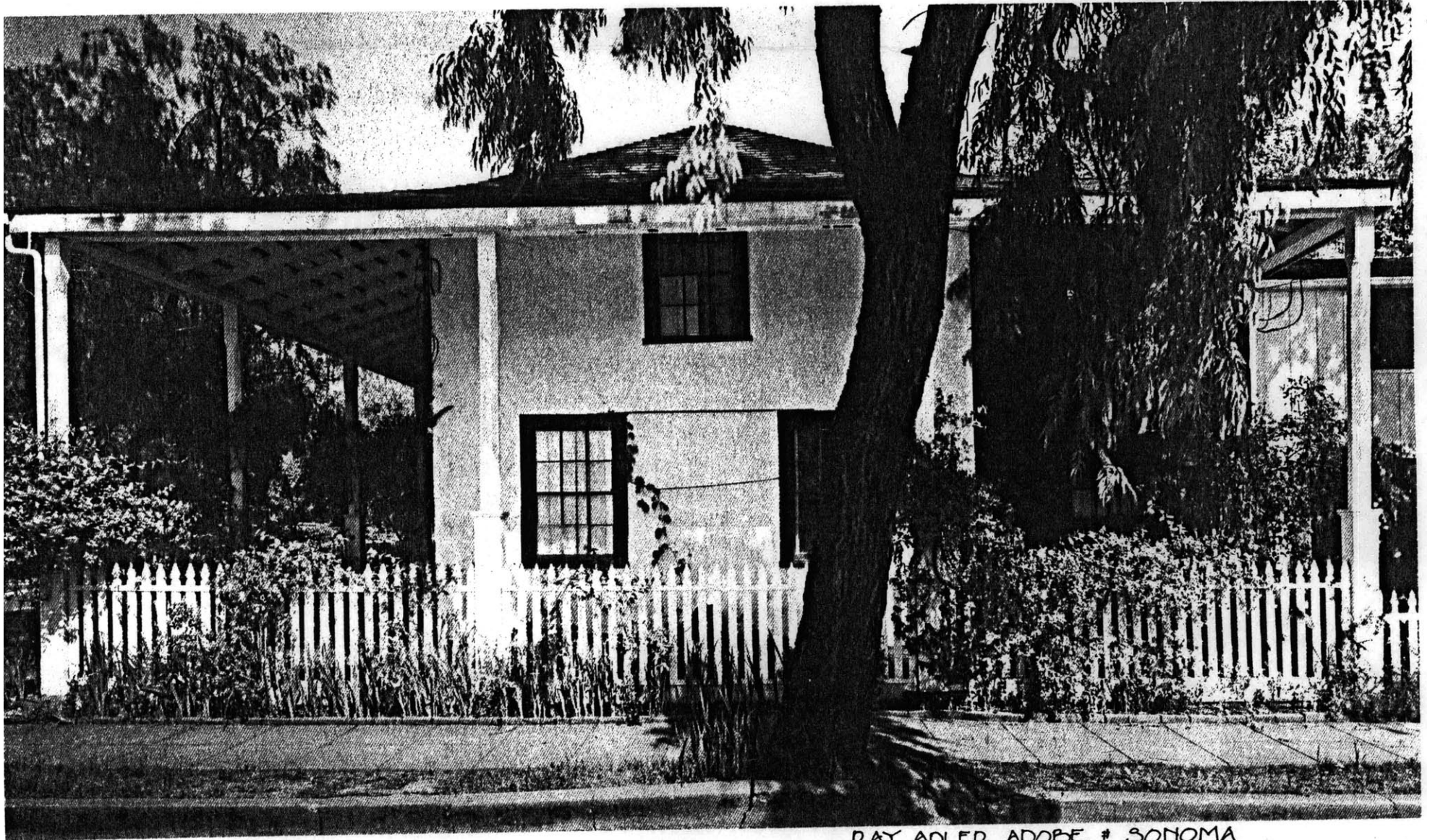

RAY ADLER ADOBE # SONOMA





Monterey Colonial style often have hipped roofs.

In an adobe building, the roof is particularly important. Due to the water solubility of the earthen walls, the roof must protect them from inclement weather. For this reason, adobe buildings have deep overhangs. These overhangs further emphasize building linearity and bring its mass towards the ground.



## Presentable Facades

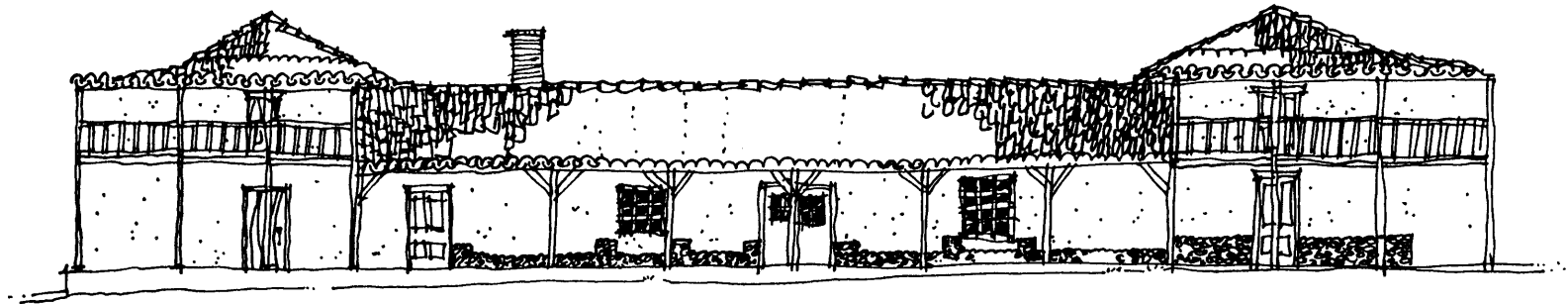

CUSTOM HOUSE # EAST ELEVATION

One of the great attractions of adobe structures and contributes to their success as building complexes, is the fact that they rarely have a blank or "back" facade. While each facade may differ dramatically in

reaction to climate, site, or use, all elevations are presentable to the visitor. The multiple direction of their orientation contribute to the wholeness of their design.



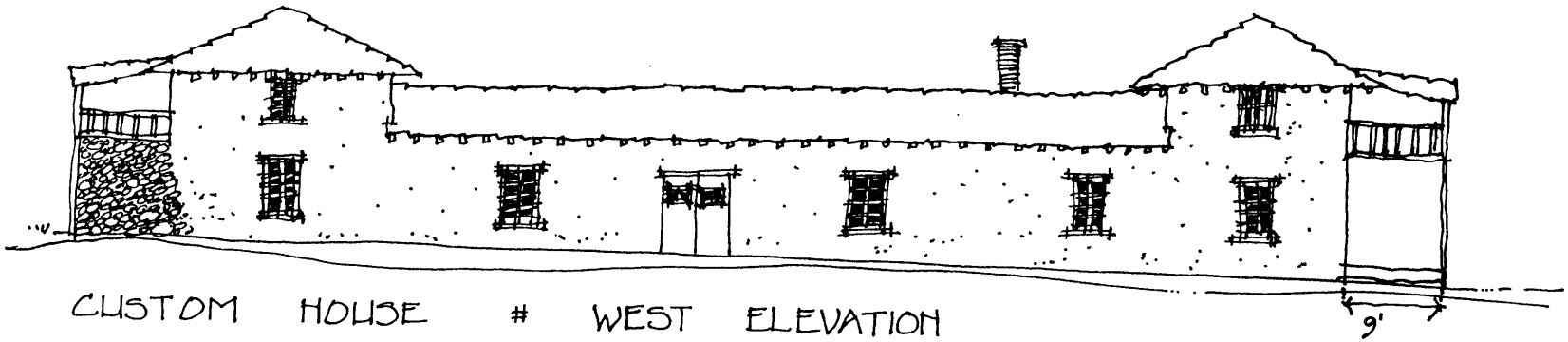

CUSTOM HOUSE # WEST ELEVATION

9'



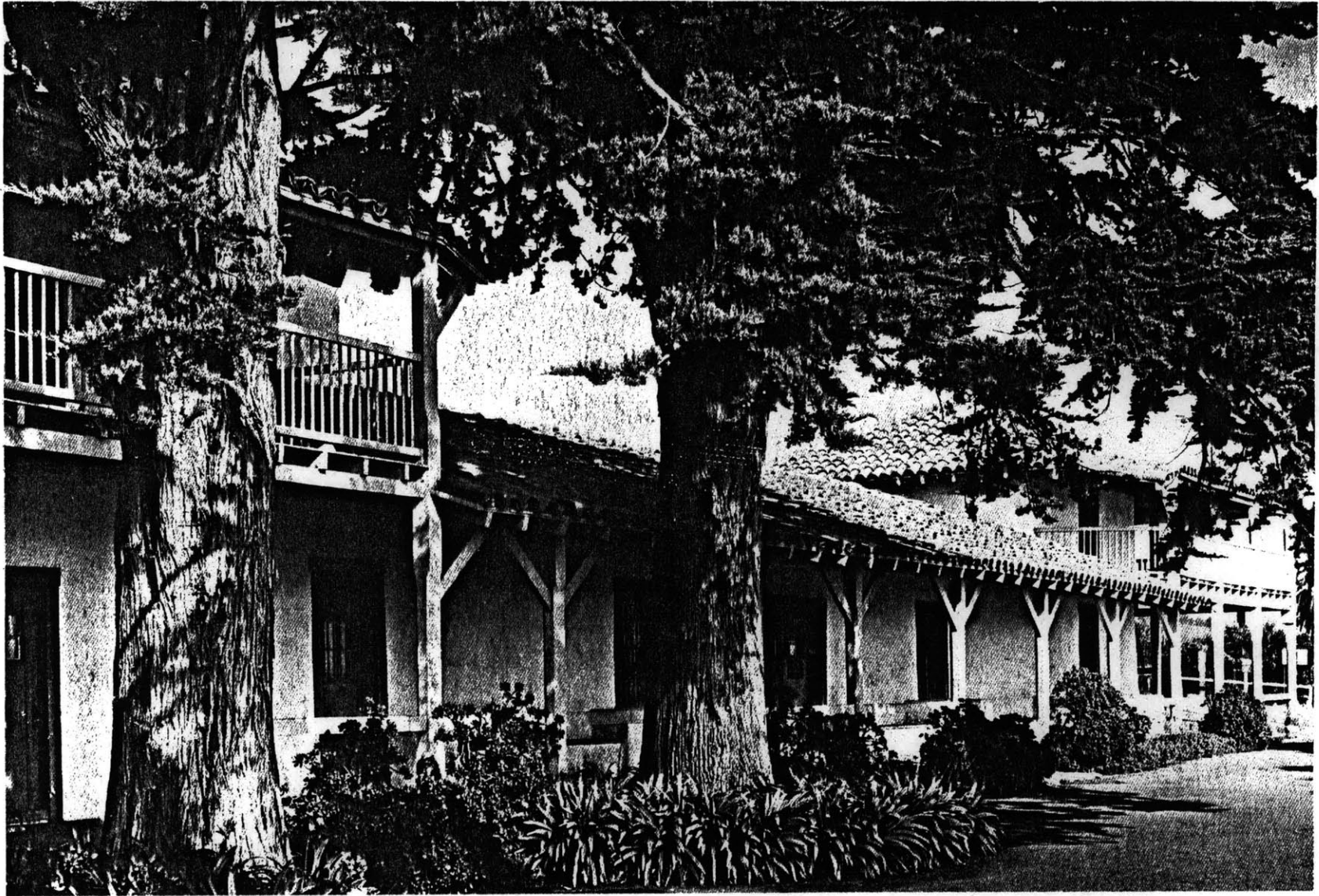

CUSTOM HOUSE # MONTEREY





## INTERIOR LAYOUT

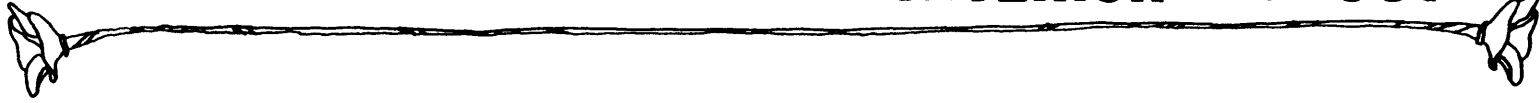

Throughout California, the linearity of the landscape is repeatedly emphasized through the flow of the water, the length of the valley's and the rise of the hills. Like the landscape, the plans of adobe structures are also linear. This linearity is necessary due to structural requirements, and demands for interior light. The resulting form has the advantage of beautifully harmonizing with the landscape and inconspicuously integrating itself with in it.



## Rectangle Plan

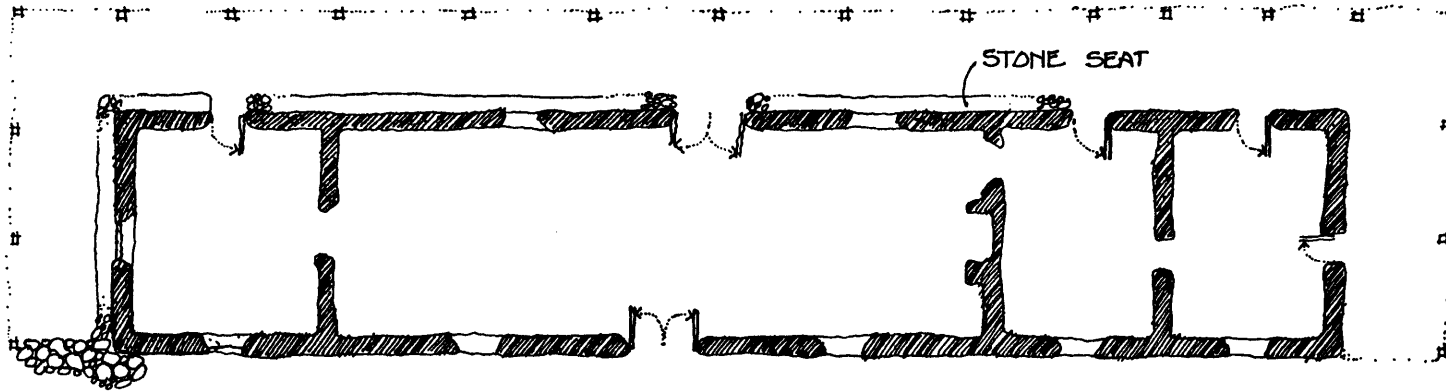

◀ NORTH # CUSTOM HOUSE # MONTEREY  
LINEAR PLAN

The earliest and most primitive California adobes were rectangular in plan and general form. They were one story high and generally composed of 2-4 rooms, each leading into the next. The center room was generally

the largest and served as the family living space. The smaller end rooms were bedrooms. A corridor was built on the exterior by extending the roof line. This covered passage served as the primary circulation space.





The lack of adequate interior circulation space was this plans' primary disadvantage. Additionally, the linear relationship between rooms emphasized each room as a singular entity rather than encouraging a dynamic relationship with it's neighbors.

With a rectangular plan it is difficult for the building form itself to claim or create positive outdoor space. This can only be accomplished when a three sided garden wall is attached.



## Courtyard Plan

As the wealth of early settlers increased, they added on to their initially modest homes or built new ones. These grander homes had "L" or "U" shaped plans which were known as courtyard plans. With its wings extending into the site, the courtyard plan embraces the landscape, claiming the central space as a courtyard for its inhabitants. This plan was expressive of the gracious unhurried life of early residents.

A visitor enters a courtyard home through a large door leading from the street directly into the patio. A corridor runs around the perimeter of the patio. Each room in the house 'opens' directly onto the corridor. Like the rectangle plan, the corridor serves as an exterior circulation space in the absence of an interior hall.

The layout of rooms finds the public living areas in the central wing. Bedrooms or work spaces are located in the extended wings. This plan was usually only one story in height. But with increased wealth, the central wing might be raised to two stories. A large "sala" or entertainment room was usually located on the second floor.

The courtyard house was a vast improvement on the early simple plans. By embracing the landscape, the form of the house itself forges an unalterable relationship between its inhabitants and the outdoors. But like the rectangle plan, the interior circulation zone must be more self contained for successful adaptation to contemporary privacy requirements.



CASA DE LA GUERRA # SANTA BARBARA

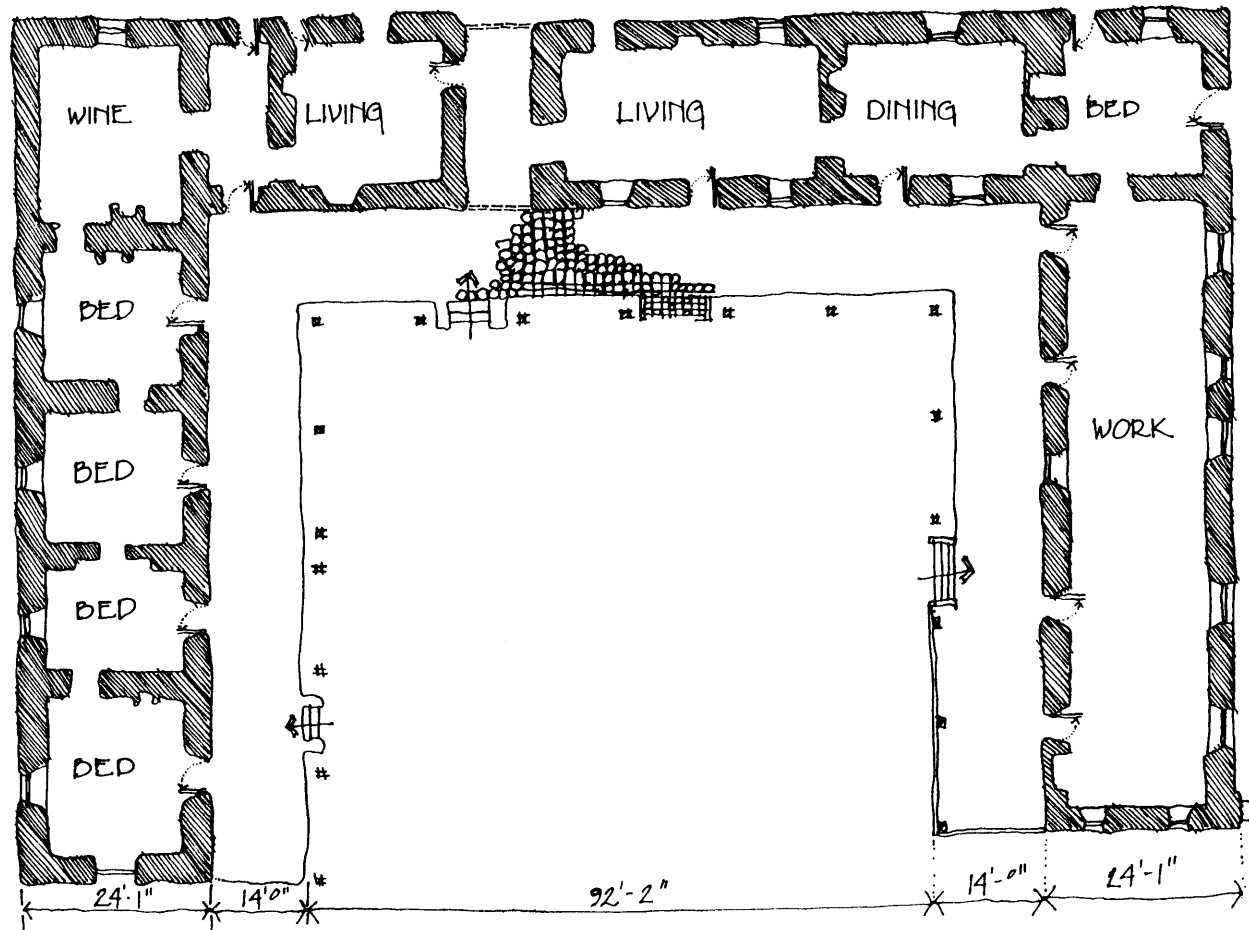

## Center Hall Plan

---

As discussed in the introduction, the construction in 1835 of the Larkin House, suggested a new plan typology for adobe dwellings. The plan was heavily based on the New England architectural tradition and lacked some basic understanding of architectural requirements in California such as cross ventilation.

The building of Casa Amesti integrated the center hall with a more sensitive California building typology. It is an excellent example of the center hall plan. In this plan, the visitor enters directly off the street and on to the corridor. The courtyard is found to the side or back. Through the main door, they enter directly into the hall,

off of which open the public living rooms. Bedrooms or more private common spaces are located beyond these rooms or up the stairs - located in the center hall - on the second floor.

In this plan, interior circulation space has been provided. This allows the building to become two rooms wide. Consequently, rooms have a single outdoor facade rather than the double exposure found in earlier plans.



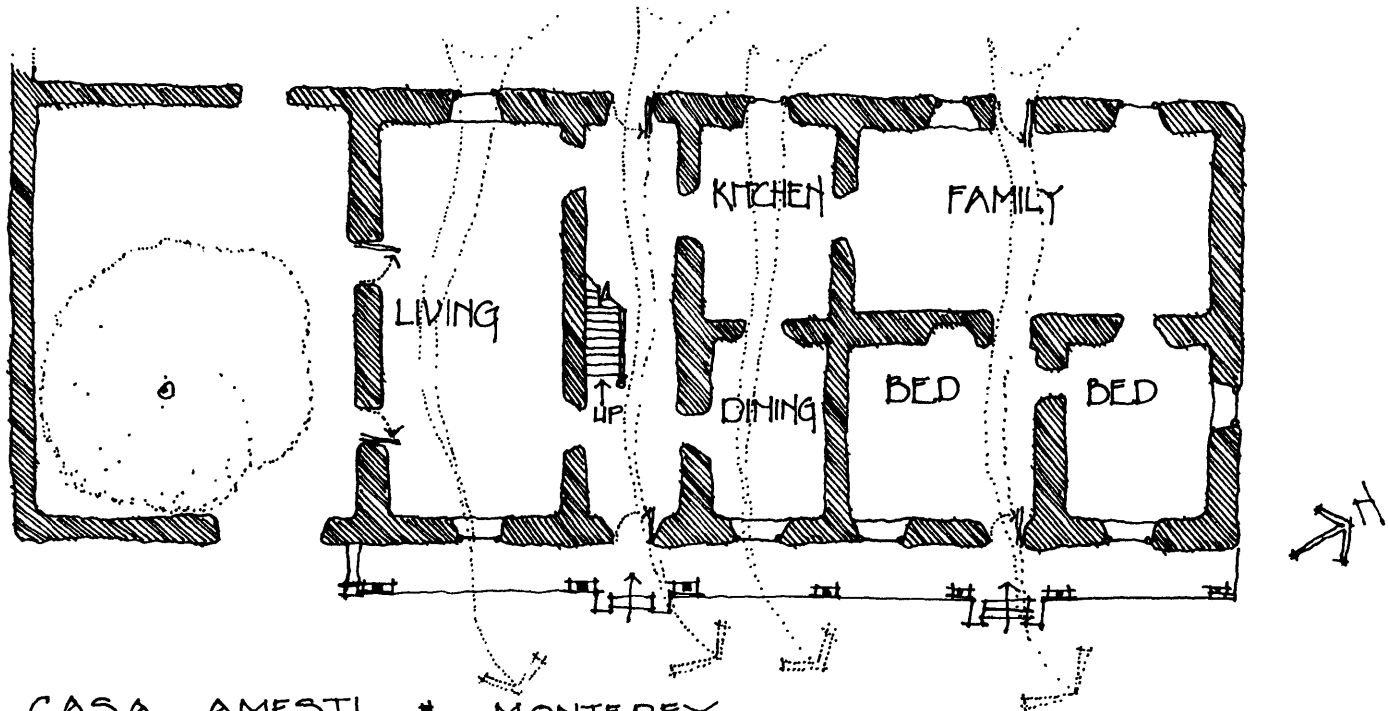
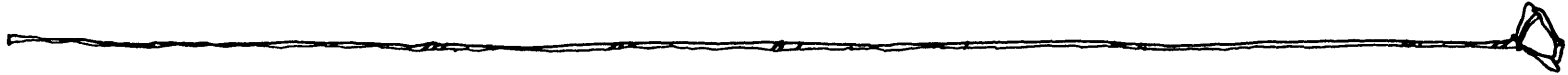

CASA AMESTI \* MONTEREY  
CENTER HALL PLAN



# Privacy Hierarchy

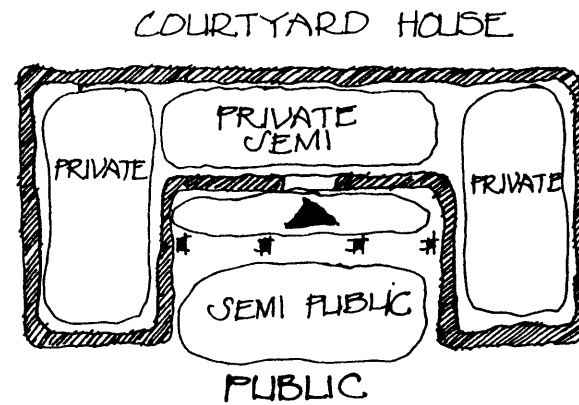
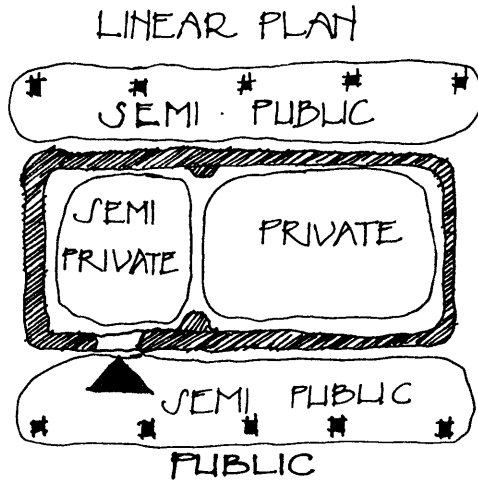

## PRIVACY HIERARCHY

Intrinsic in the three basic plans is a privacy hierarchy which defines and differentiates between four privacy zones: public, semi public, semi private, and private.

"Public Space" is defined as area rightfully transgressed by everyone.

"Semi-Public Space" is a transition zone between public and private. In this case it is the exterior space adjoining a private



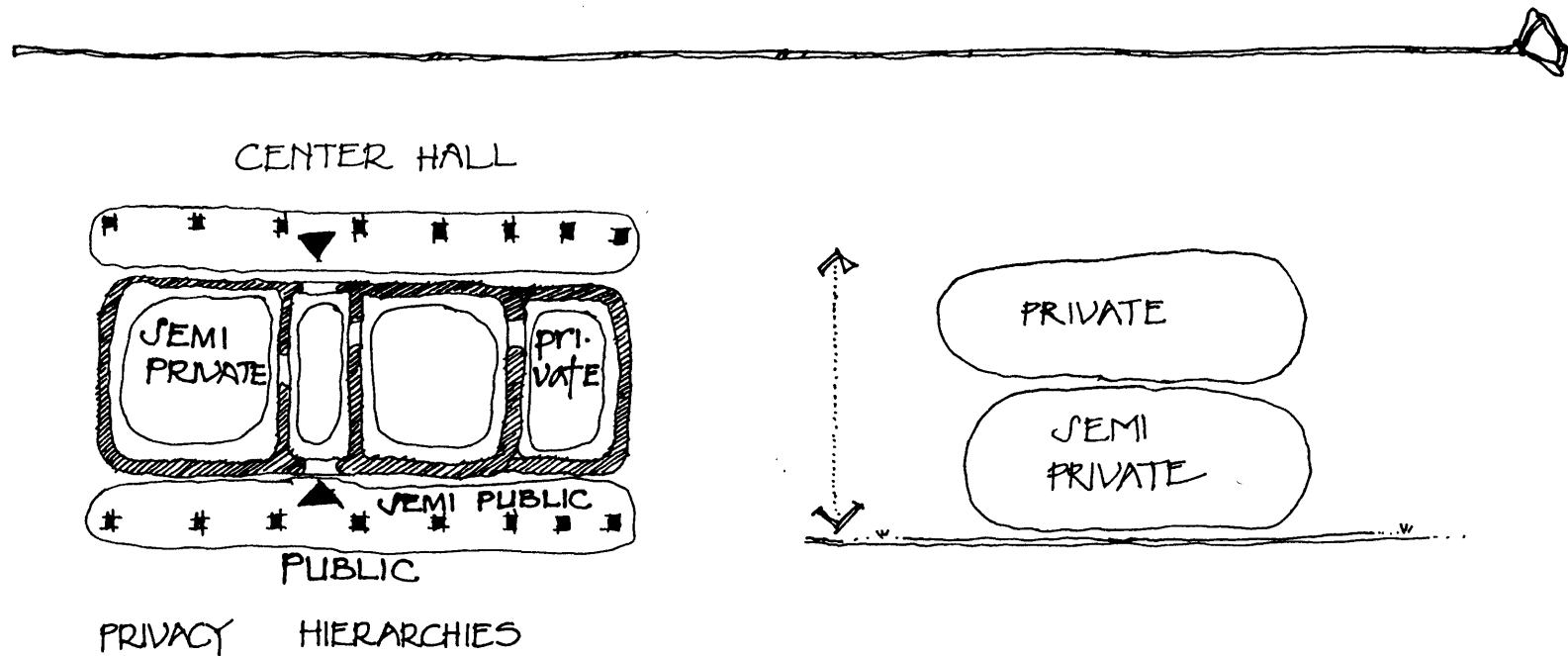

building where visitors might be assessed. In practical terms, it is the corridor or courtyard of an adobe home.

"Semi-Private Space" is the area open to admittance to family and friends. It is a

group's private realm such as a living room.

"Private Space" is the territory controlled by the individual. In a home, this space is a bedroom.

In the horizontal dimension, the privacy



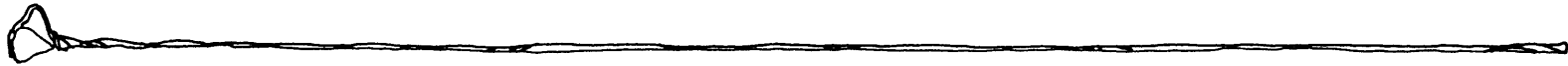

hierarchy is well defined by the California adobes. Public space is that area beyond the corredor or garden wall facing the street. The semi-public space is contained within the corredor or courtyard. The semi-private areas are located directly off the main interior entrance, most often towards the center of the building. The private space is beyond the semi-private and at the edge of the plan.

In the vertical dimension, semi-private space is generally found on the first floor with private bedrooms located above. Where salas were originally located on the second floor, they have usually been transformed into bedrooms.

In contemporary design it is imperative to maintain this privacy hierarchy. All too often, distinctions are broken down between zones, resulting in a loss of understanding in the built environment or an inability to claim space as an individual. In areas of dense construction it is particularly important to create adequate semi-public space in order to differentiate between one private space and that of a neighbor.



## Sun Definition of Use

The privacy hierarchy is of primary importance in laying out a house plan. However, within the hierarchy, the sunpath defined use areas and wall openings of adobe structures.

The most common layout finds bedrooms, the kitchen, and work space opening up to the east to catch the morning sun. The large living and eating areas would catch the afternoon sun to the west. Outdoor spaces extend all the way from east to west with storage and service areas claiming the shaded north.

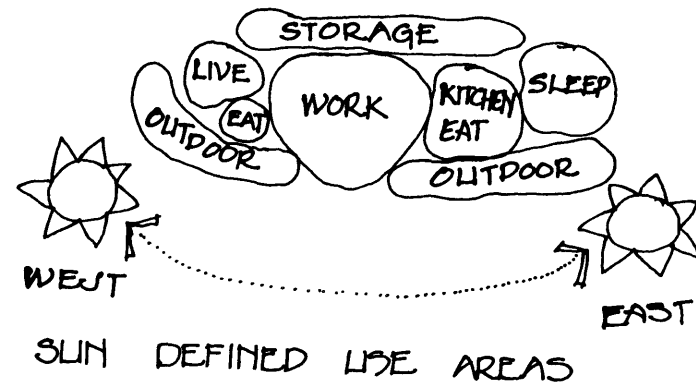

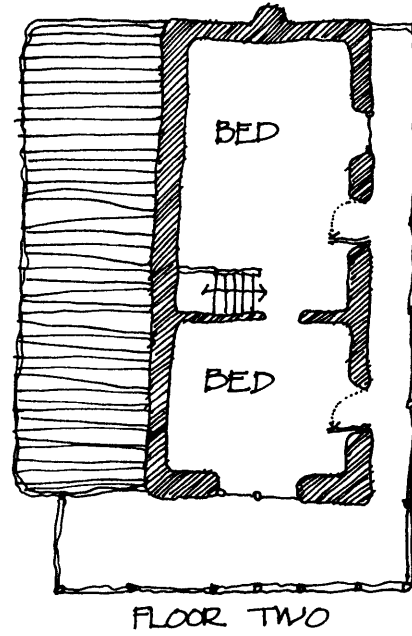
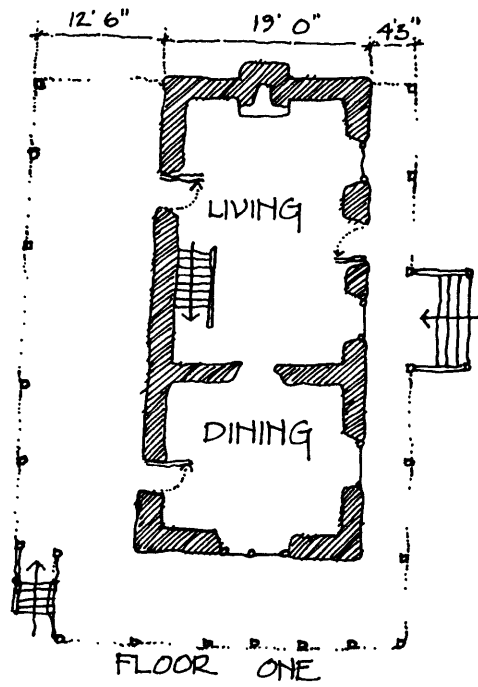

THE MARTINEZ ADOBE  
SUN DEFINED USE AREAS



## Exterior Access

In early adobe dwellings it was necessary for all rooms to have direct access to the outdoors because circulation occurred through an exterior corridor. But even with the advent of a central, interior circulation hall, the direct relationship between every interior room and the outdoors was maintained. This relationship allows the resident to take full advantage of the outdoors, maximum light is admitted to each room, living space is extended and the privacy hierarchy for each room is expanded. It is a condition as desirable today as it was during the colonial period.

Californians live from outdoors to indoors. The relationship between these

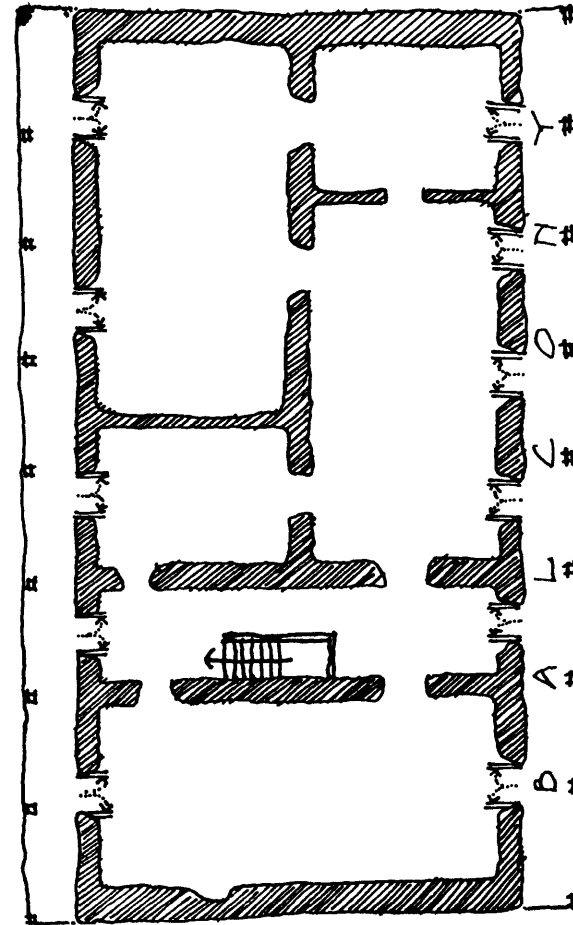

CASA AMESTI # FLOOR TWO  
EXTERIOR ACCESS



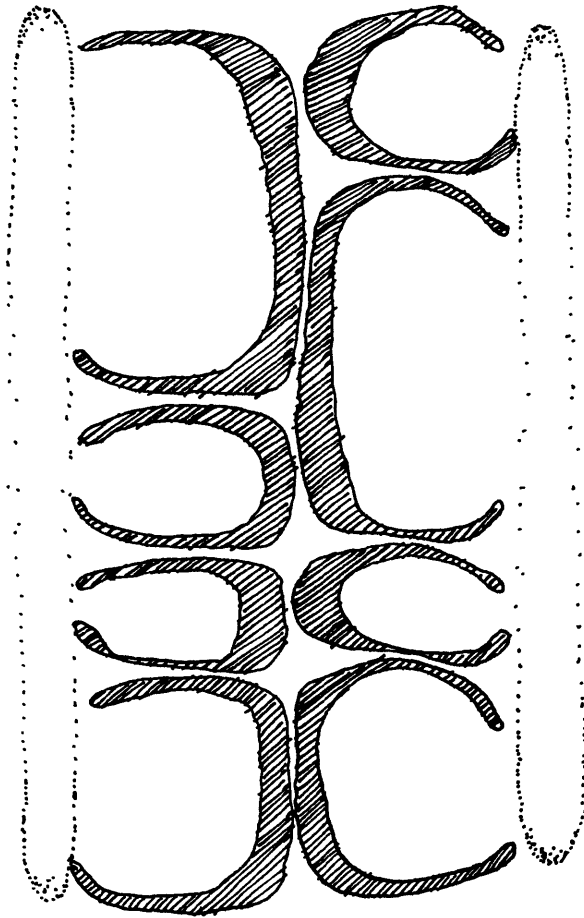

CASA AMESTI # FLOOR TWX  
EXTERIOR ACCESS

spaces should not merely be a window that visually connects these spaces, or a door that opens. It should be a complete sheltered area which defines a space in itself.

Common living areas should have a free flowing connection to the corridor and patio in a relationship where all these spaces are connected with one another. Through such a relationship, the living space of each is extended. Private areas such as bedrooms should have walled in patios or balconies for the exclusive use of their inhabitants.

When designing a building, each room should be laid out in a manner where it is defined by both interior and exterior space.



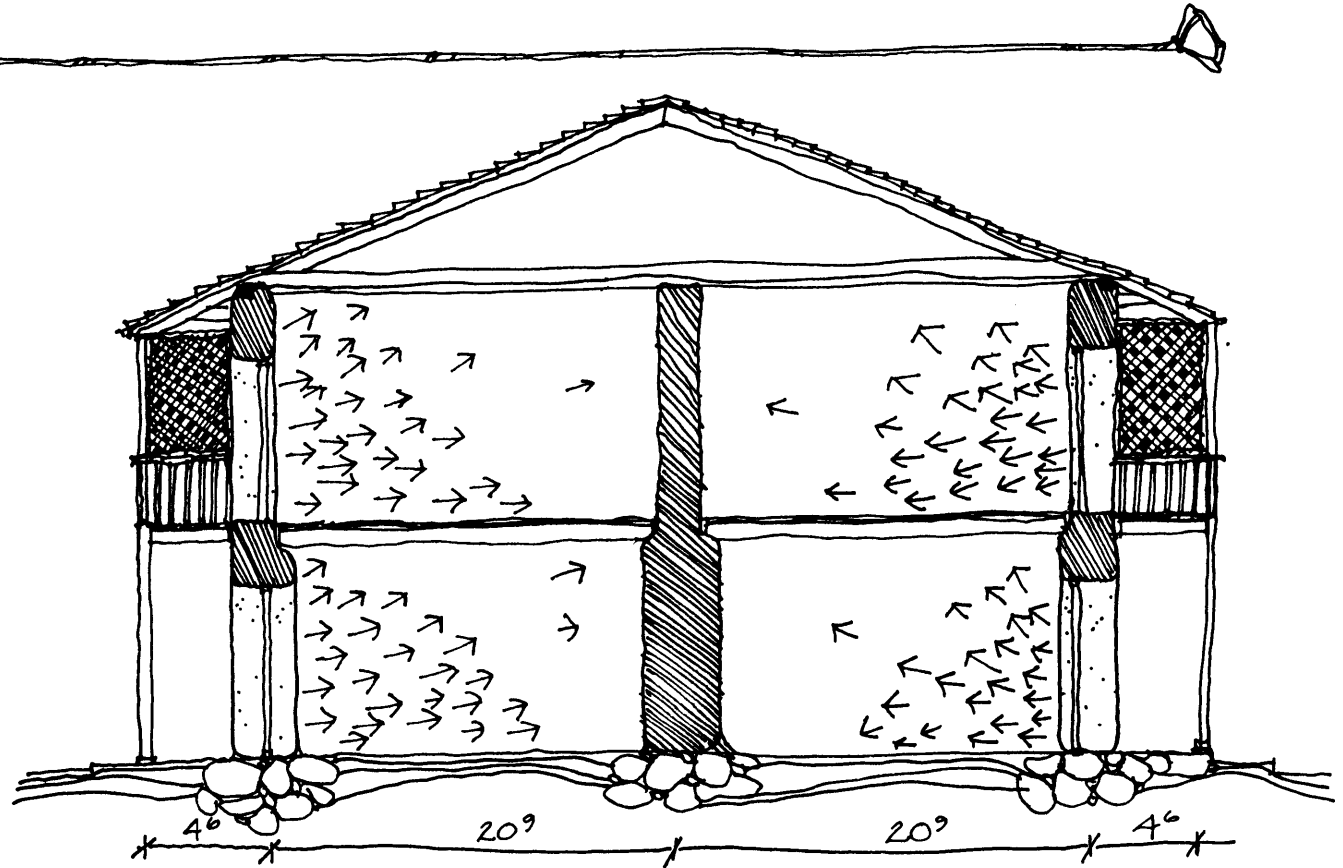

CASA AMESTI # SECTION  
LIGHT

Care should be made in the quality of the complete elements but in combination, they connection so that seperately they are become dynamic.



## Separate Structures

---

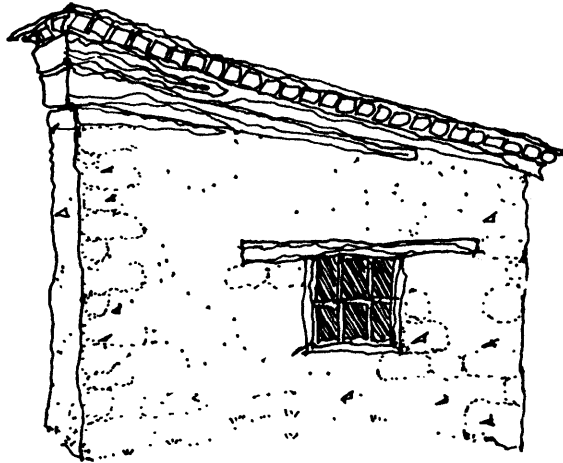

MONTEREY'S FIRST THEATRE  
SERVICE SHED

One must temper their romantic vision of early life in adobe dwellings with a realization that this life lacked many of the comforts we take for granted today. In the

absence of indoor plumbing and adequate ventilation for extensive cooking, tasks requiring such facilities were shunted to separate structures. These lean-to's were found on the edge of the property.

Today of course, the kitchen and bathroom have been incorporated inside of the house thus greatly increasing a home's comfort. Yet there are still some activities which might logically be placed in structures separate from the main building. These activities could include the garage, storage facilities, a workshop, or even a guest cottage. Through the detachment of some spaces, together with linkage elements, the creation of a building complex becomes more tangible.



## INTERIOR- EXTERIOR INTEGRATION

Successful integration between indoor and outdoor spaces is paramount in expanding the area claimable as living space. Outdoor space makes indoor space seem larger. Outdoor space has a beneficial effect upon life within the house. A terrace outside a living room extends the living space beyond the walls of the house into the landscape. Even when weather will not permit the use of the outdoor area, it seems to make the inside room larger both visually and emotionally.

From an economic standpoint, the extension of indoor space through its proximity with outdoor space is crucial. Exterior space is much less costly to construct. Thus, if the weather is

successfully manipulated, the dwelling gains an additional room at minimal cost.

Adobe structures use a repertoire of landscape and built elements to protect the structure from erosion and create a variety of outdoor spaces. Today we can continue to use these elements for privacy, climate and light manipulation.



# Hierarchy of Outdoor Space

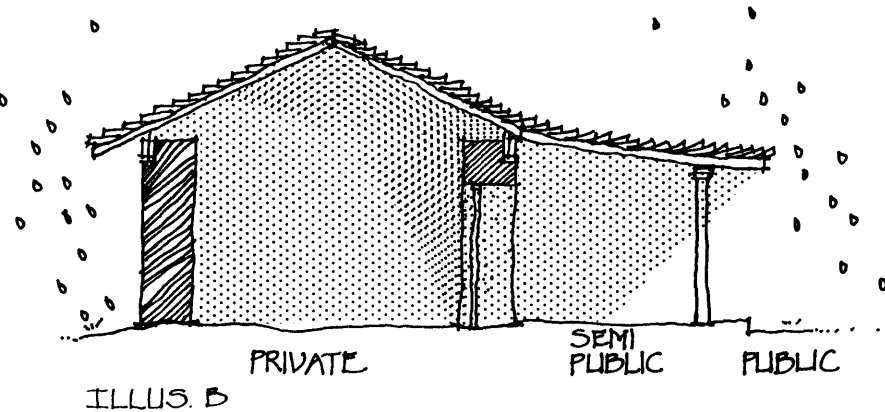
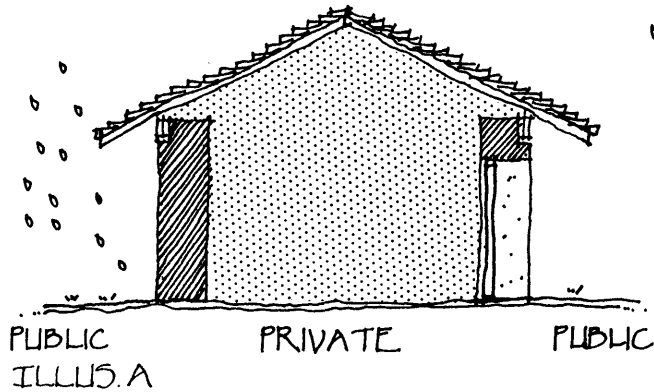

Integral to the privacy hierarchy discussed earlier, was the use the corridor and patio to define semi public space and make the first declaration that private property exists separate from that of the public. In a discussion of outdoor space, this concept must be expanded in order to fully understand the breadth of contribution these elements make towards the privacy hierarchy. It should also

be realized that these elements initiate hierarchies of climate and light manipulation.

In adobe structures, the primary elements used in exterior space definition are the corridor, the patio or courtyard, the garden wall, and the trellis. Later in this section each of these elements will be discussed individually. Presently, it will be explored how these elements work together to form a



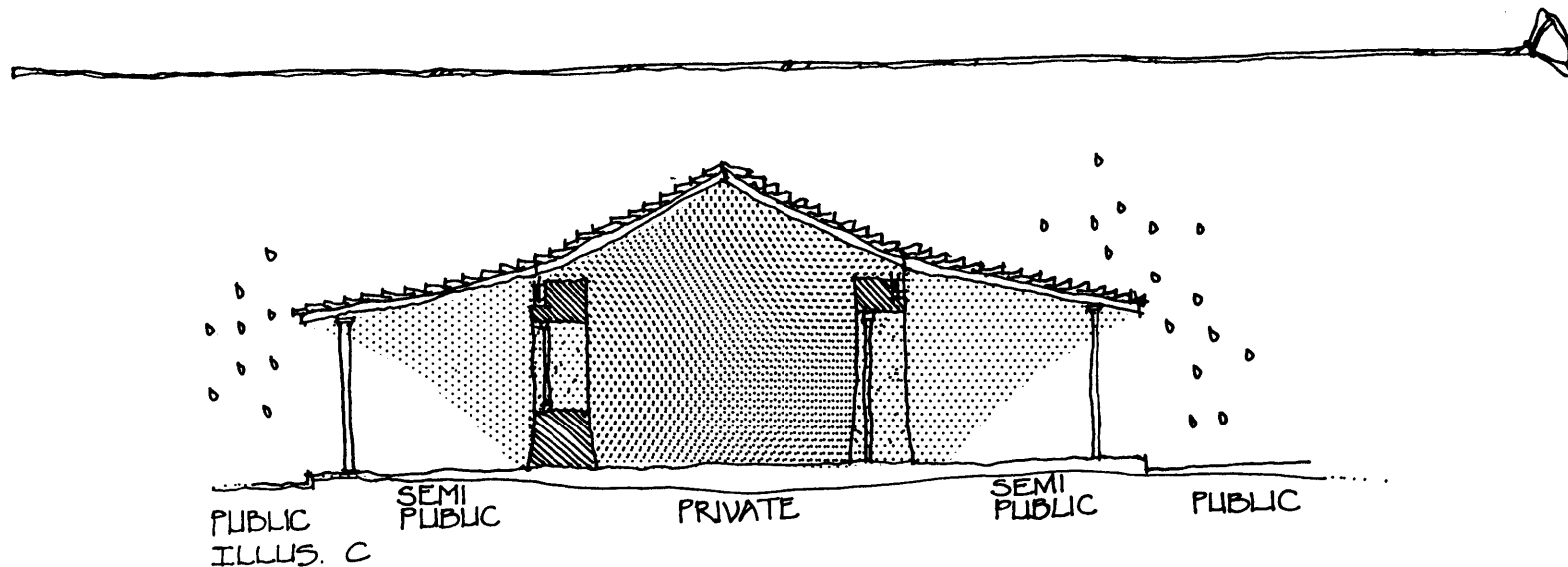

hierarchy of spaces differentiating qualities of privacy, climate, and light.

At its most primitive level (illus. A), the adobe structure is simply placed upon the landscape. Its interior space is private while its exterior is public. It could be argued that it does claim some territory beyond its walls as semi-public space such as the area under its eaves. However, this area

is ill defined and difficult to defend as an absolute so it is considered essentially public. Climate control is simplistic. The dweller is protected inside but immediately outside the door she is essentially exposed. Likewise, light exists at two levels. It is dark inside and light outside.

With the addition of a corridor, (illus. B), a semi-public zone is introduced. For the



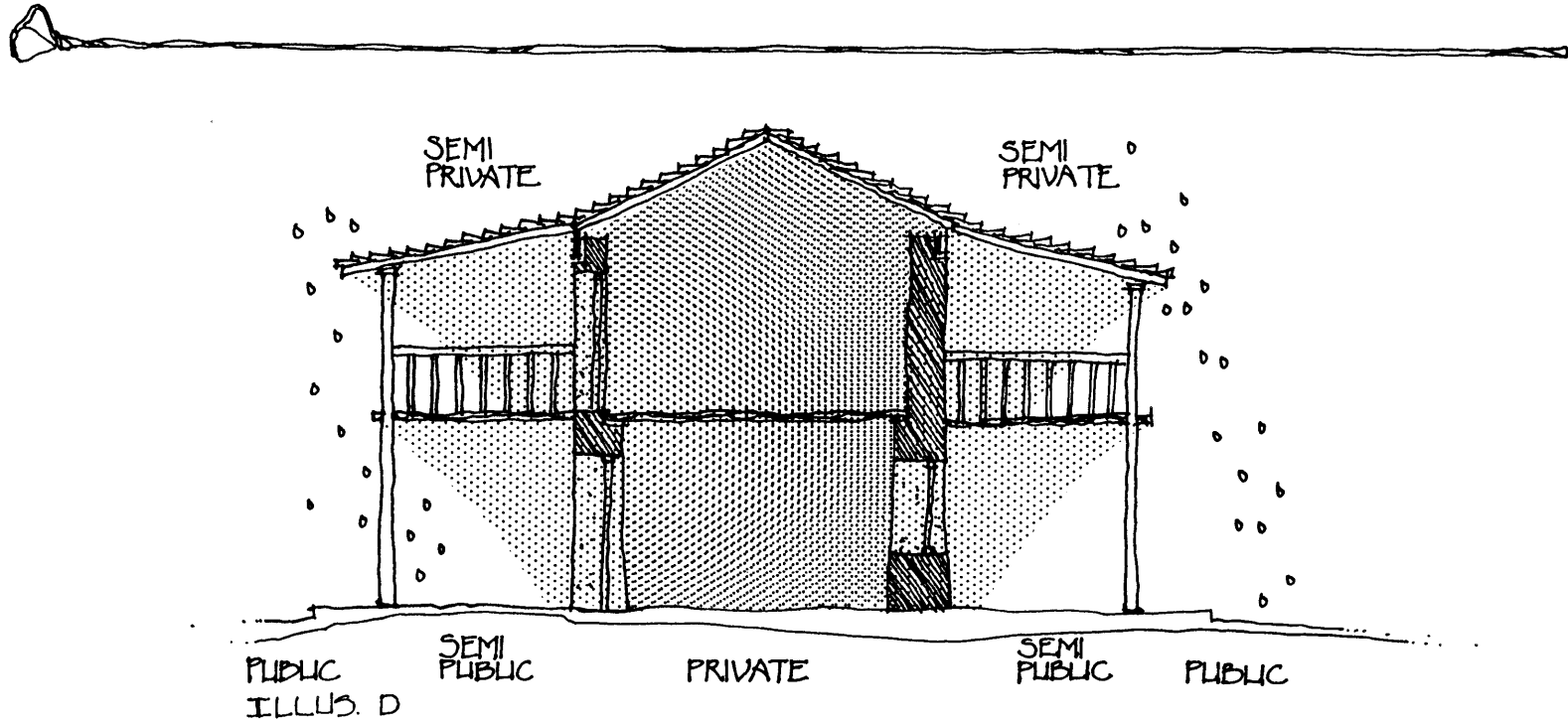

first time, area beyond the building's walls is definitively claimed as belonging to the dwelling. A transition zone is formed where visitors can be assessed before admittance to the private realm. Conversely, it is a territory where residents can observe the

public while under the protection of their own property. In addition to a sense of safety, a corridor creates a climatically protected outdoor territory. It expands the amount of living space available in mild inclement weather. It allows more climate protection to



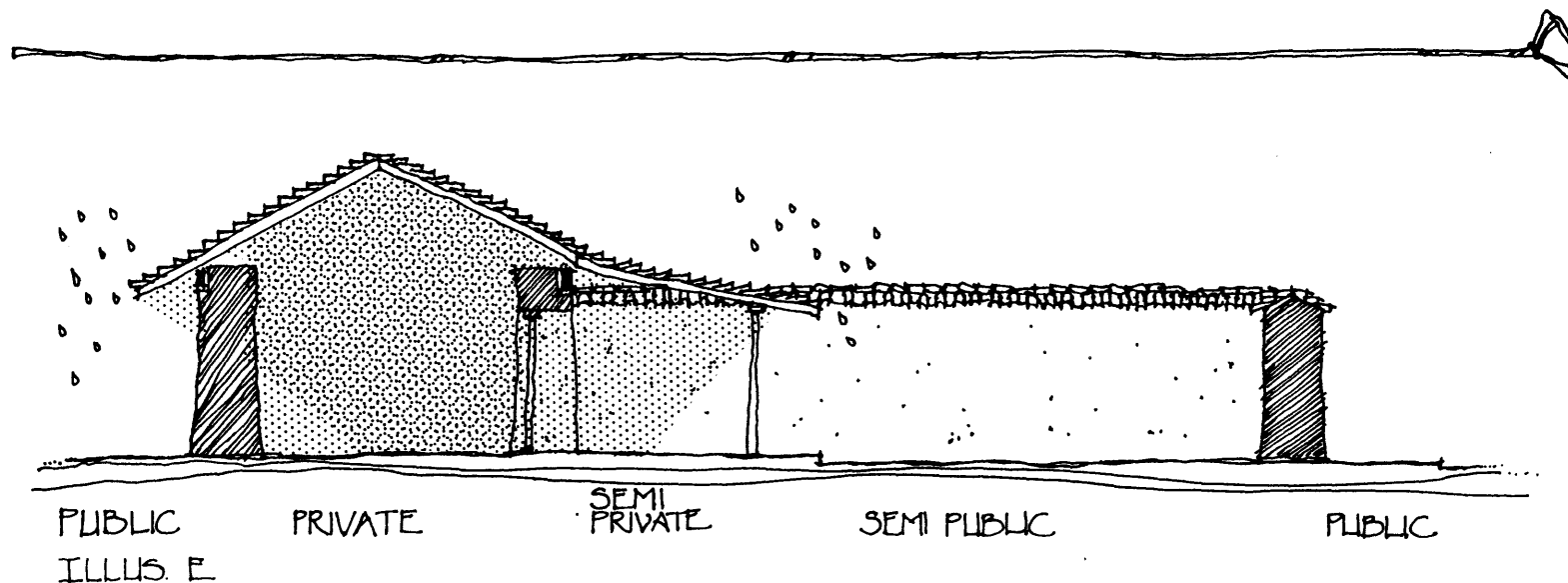

delicate adobe walls than a simple extended overhang. A corridor also creates an intermediate zone of light. The corridor itself receives filtered light. However, the light levels to the interior area, just beyond the corridor are greatly diminished.

A corridor on each side of the adobe structure (illus. C), is a common condition.

This configuration relatively equalizes the qualities of privacy, climate and light on each side of the building. Differences in qualities will arise through environmental factors. Light levels will vary at different times of day. Privacy will differ depending on building access, and weather penetration will be determined by the direction of prevailing



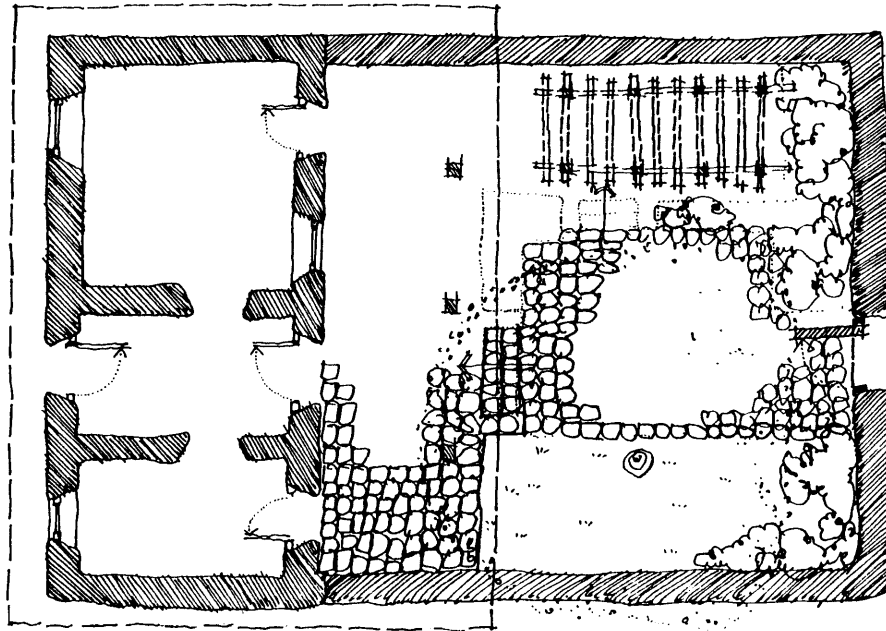
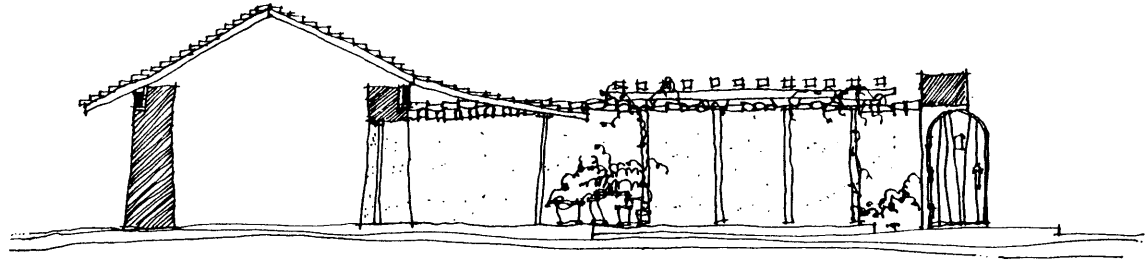
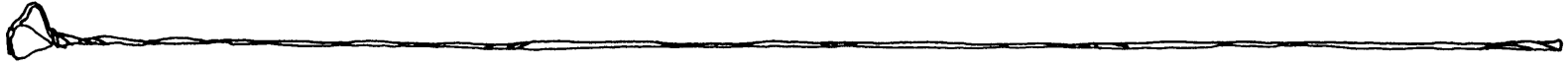

ILLUS. F



---

winds. In view of different environmental effects, it may be prudent to determine the form of each corridor individually.

A balcony placed over a corridor, (illus. D), creates outdoor space which is more private in nature than the corridor due to its limited access. It connects upper levels with the outdoors while its manipulation of light and climate is similar to that of the corridor.

When a garden wall is used to enclose territory beyond the dwelling, (illus. E) the semi-public territory is greatly expanded. The corridor starts to read more as an extension of the interior living space and becomes semi-private. This is possible

because the area between the garden wall and the corridor acts as the transition zone between public and private. The courtyard thus formed becomes an outdoor room. The wall serves to block unwanted winds and allows living to extend into the space on sunny but windy fall and spring days. The light in this area will be manipulated through sensitive plantings and the addition of trellis's, (illus F).



## Corredor

---

The role of the corredor added to an adobe building has been repeatedly discussed in previous sections. That it served as the traditional circulation space, extended the interior living area and protected fragile adobe walls is well known. What remains to be discussed is the form which guarantees it's success.

Historically, the corredor would extend across the entire facade of a building, wrap it's courtyard or completely surround a house. But it's length is not as important as realizing that it's function was to connect a sequence of spaces. Thus, in contemporary

construction, it may not be long but it should certainly forge a link and offer alternative circulation between rooms.

The corredor is a dynamic element because it fulfills a variety of needs. It is not simply a circulation realm but an outdoor space. To be a space, the corredor must have adequate dimension. Traditionally, they are between 6' and 10' wide. With a width of 4', the corredor is only a path. But if it has a minimum width of 6' it is a place to sit as well as a path.

Vertically, the corredor roof gently settles the main roof towards the ground



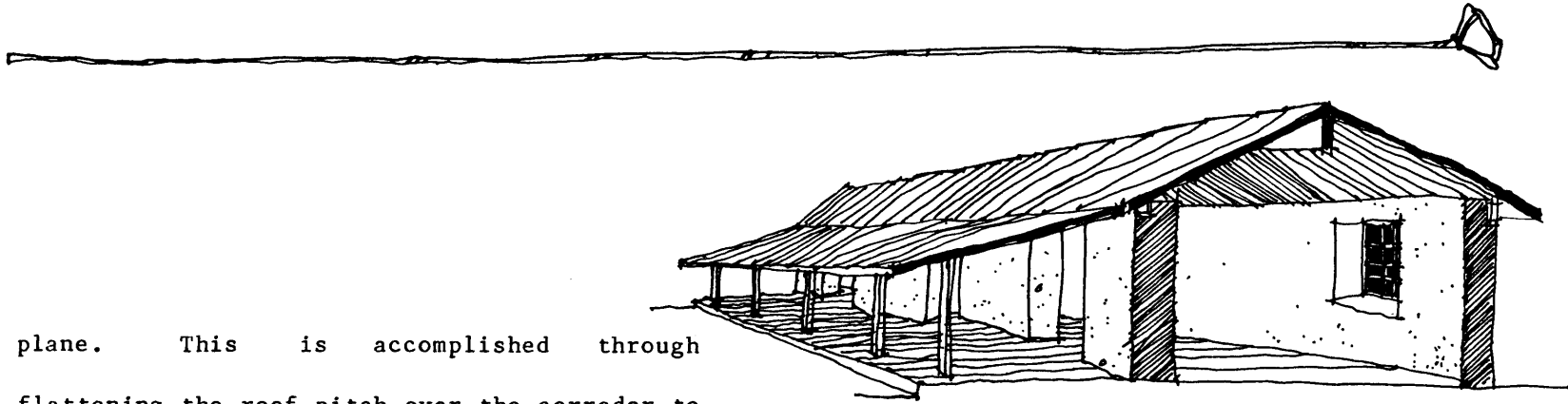

plane. This is accomplished through flattening the roof pitch over the corridor to a slope of 3" to the foot. At the face of the corridor, the ground to roof height is traditionally 9', rising to 11' at the wall edge.

In California, bugs are not a problem. Thus, if the corridor is properly constructed, the dweller will be constantly invited to throw open the doors for a cool breeze or step outside. An undeniable link between the indoors and outside will be forged.

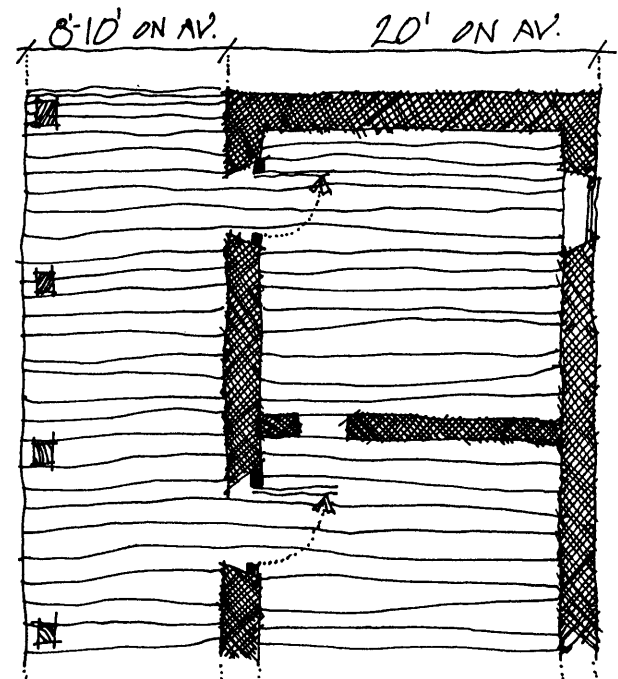

# Courtyard

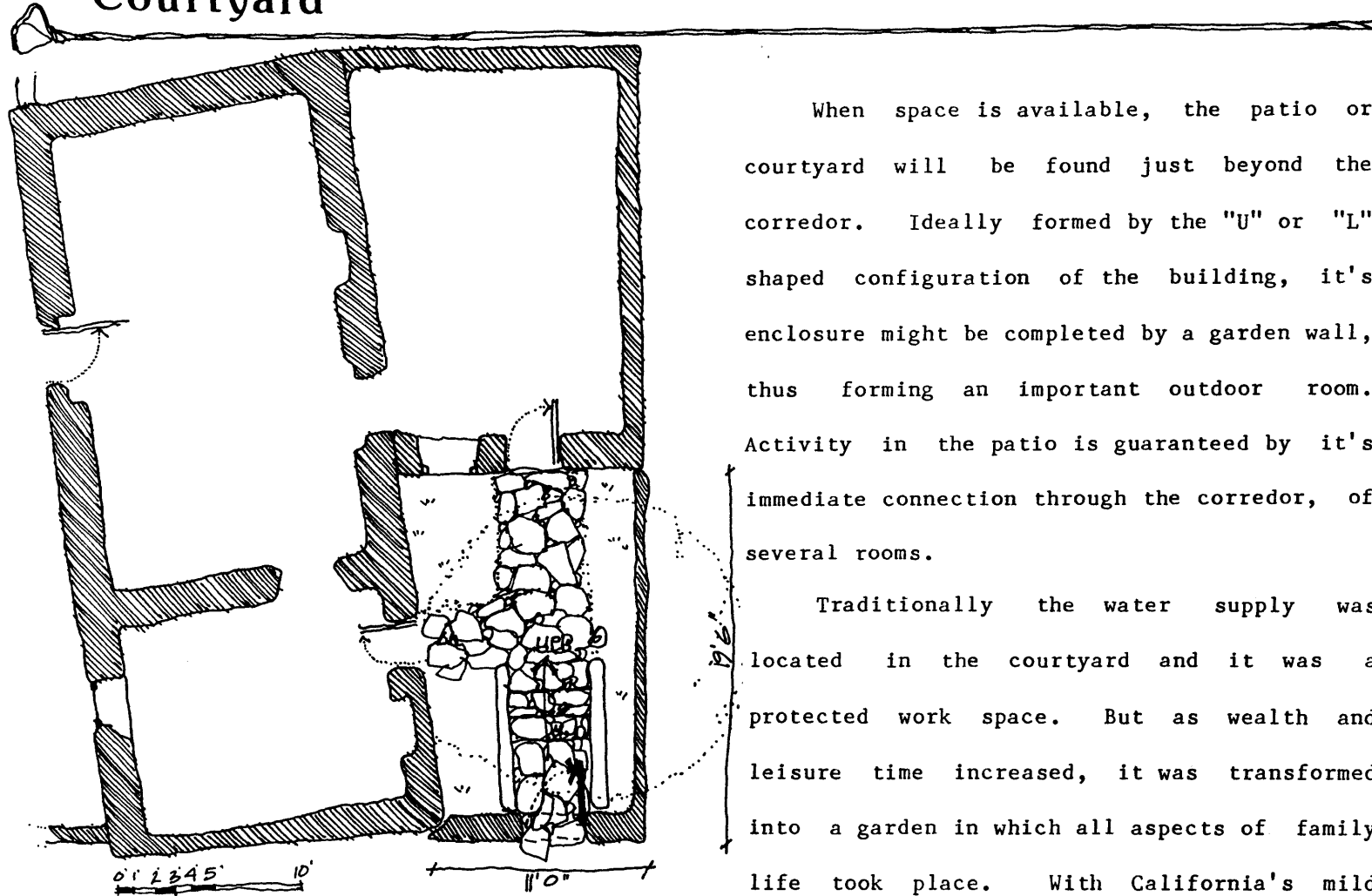

When space is available, the patio or courtyard will be found just beyond the corridor. Ideally formed by the "U" or "L" shaped configuration of the building, its enclosure might be completed by a garden wall, thus forming an important outdoor room. Activity in the patio is guaranteed by its immediate connection through the corridor, of several rooms.

Traditionally the water supply was located in the courtyard and it was a protected work space. But as wealth and leisure time increased, it was transformed into a garden in which all aspects of family life took place. With California's mild

EL CHARTEL  
ENTRANCE PATIO



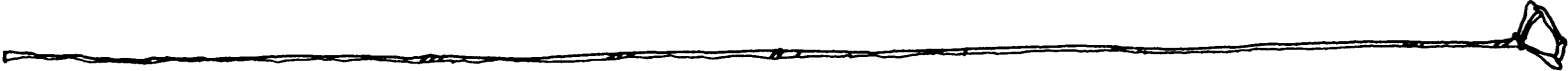

climate, this outdoor room continues to be an indispensable location for eating, cooking, sunbathing or child's play.

In order to guarantee the success of this space, its location must gain adequate sun. However, care must be taken to add landscape elements which will screen the sun during the hottest days. The courtyard should also be screened from the wind. This can be accomplished through the configuration of the building or a garden wall.

The courtyard must have adequate dimensions in order to allow a variety of activities to take place within. The minimum

dimension should be 12 feet. The patio can be made more inhabitable and inviting through the incorporation of built-in benches, niches for plants or a whispering fountain. And with the addition of a barbecue and covered eating area, it can become an outdoor dining room.

One of the most important functions of the courtyard is often that as the front room or entry room. Visitors can enter directly from the street into the courtyard before gaining admittance inside the home. The courtyard will welcome the guest while maintaining the sanctity of the home. The inclusion of this relationship seems





CASA BONIFACIO · MONTEREY





particularly appropriate in small contemporary homes where dimensions do not allow an interior entry hall. Furthermore, in high density projects, the inclusion of a courtyard can insure adequate outdoor access for all rooms by orienting the plan towards an interior courtyard.



## Garden Entrance

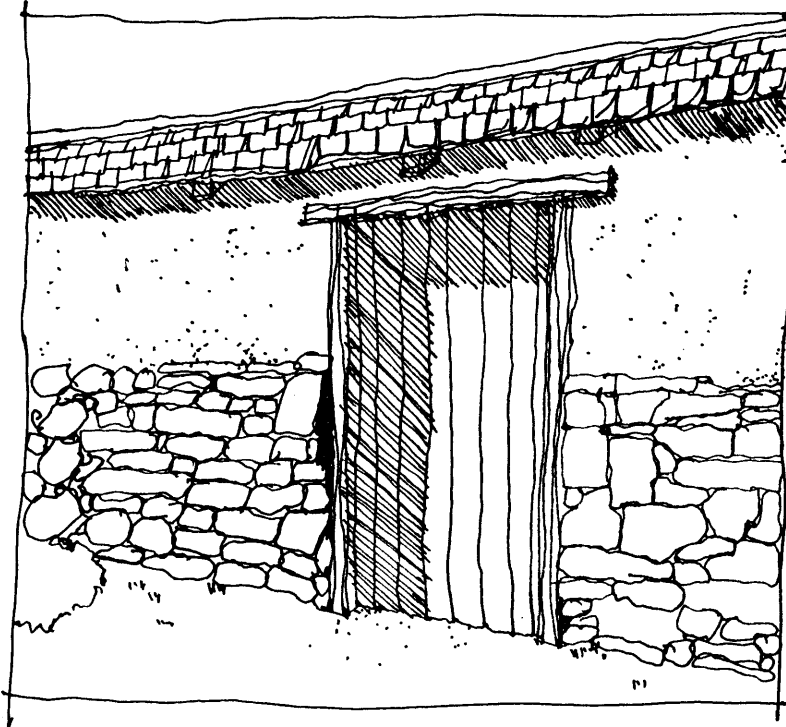

COOPER MOLERA ADOBE  
GARDEN GATE

When the courtyard serves as an outdoor entrance room, the actual entrance into it becomes very important. Every dwelling should have a distinct entrance in an obvious location. It should be controllable by the owners. Traditionally, an arch was formed in the garden wall and a strong, often ornamented wood door was hung.

What is important is to welcome the friend and discourage the unwanted visitor. The friend may be welcomed with a bench by the door upon which to rest or a bell with which to ring his arrival. Inside the wall the path to the door may be defined and protected by a covered trellis. The stranger can be discouraged by emphasizing the entrance



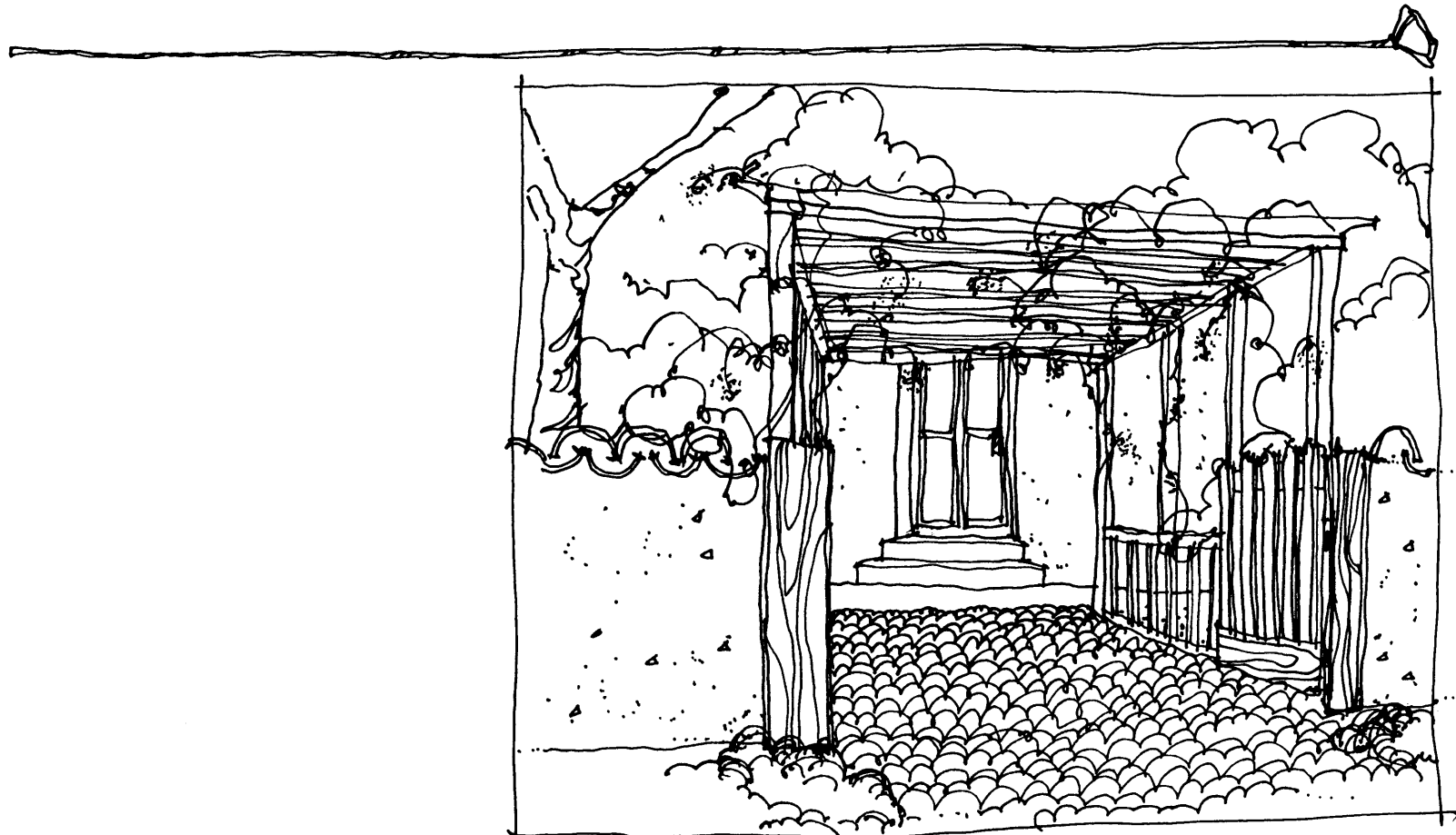

SHERMAN ROSE COTTAGE # TRELLIS

transition zone through a change of light,  
sand, direction, level, surface, and view.

he is entering a private zone and should be  
greeted before proceeding further.

These orchestrations will make it clear that





## BUILDING EDGE DEFINITION

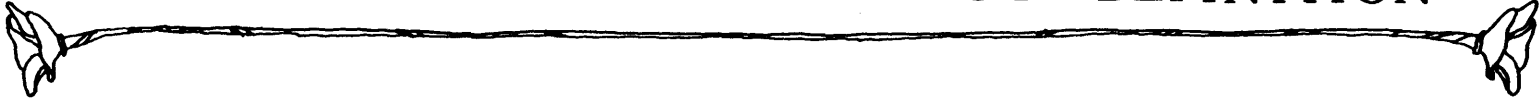

Integration between indoor and outdoor space requires more than proximity. In order for the building to meld into the landscape, the building edge must break down and open up to facilitate visual and physical connection between spaces. The buildings connection to the ground can mold a building into the landscape or set it apart. While the quality of it's openings can facilitate or discourage the transgression between indoors and outdoors.



## Foundation

---

An adobe wall meets the ground through its foundation. The foundation serves as a transition zone. It accepts the wall's massive weight and distributes it. By not allowing the adobe to touch the ground, it protects it from absorbing ground moisture which would weaken the wall. Historically, however, only light, stone foundations, if any, were used. This fact accounts for the dampness in adobe buildings and the falling of walls during severe earthquakes.

Today foundations are made of concrete. Concrete provides a strong base which prevents the wall from settling or absorbing excessive dampness. Concrete foundations help to allow adobe to be a viable modern construction

material.

At its minimum, a foundation has to provide an ample (2' plus, wide) base upon which to place the adobe wall. It must extend 18" above the ground to protect the wall from water drainage. Yet, it is easy to envision an expanded role for the foundation. It could grow into much more than the base upon which the wall is placed. It could begin to take on some of the roles of the wall itself when moves with adobe are impractical or impossible. The concrete foundation could grow into piers, or stairs.

An excellent example of this concept can be found in the historic Monterey Custom House. Its adobe walls are built on a stone



---

foundation. This foundation grows to become a fireplace and a garden wall. In the front, it extends 18" above the floor and widens to four feet becoming a seat at the base of the adobe wall. Thus, the growth and expansion of the foundation, can firmly root an adobe structure in the landscape.

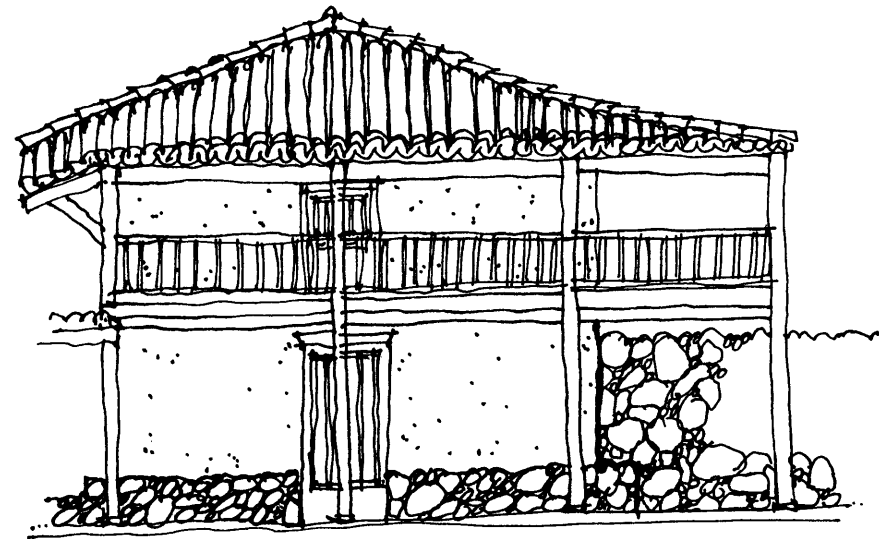

CUSTOM HOUSE  
FOUNDATION



## Garden Wall

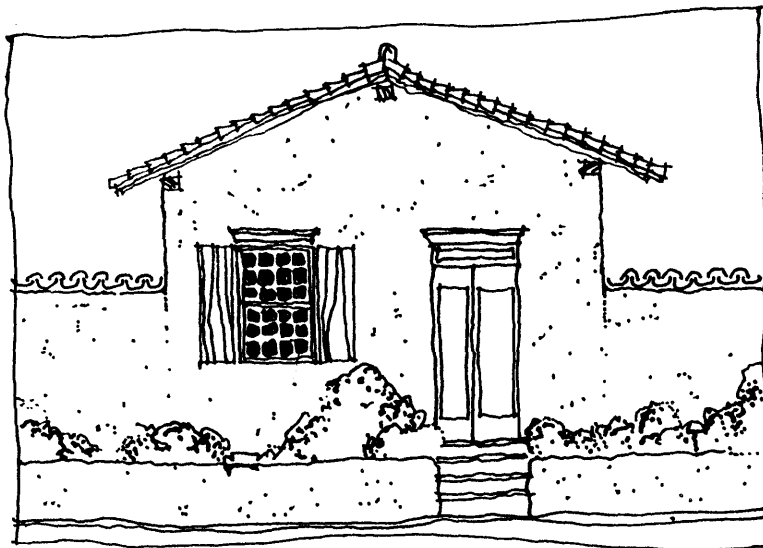

SHERMANS QUARTERS # MONTEREY  
GARDEN WALL

The traditional adobe structure uses its walls as the device with which to define enclosure. In many ways the building will resemble a shoe box with punched out openings. However, adobe walls do begin to break down when they are used as garden walls. The garden wall enclosed the courtyard and or connects outlying buildings. And because of its lower height, it starts to bring the continuous wall line of the building into the plane of the landscape.

An adobe wall flows from the pitch of the roof to the base of the floor. But due to its malleable nature, it can transcend itself. It can widen into a window seat, then flow up into a counter, then a garden wall. Niches





can be carved into it for plants, keys or the mailbox. The garden wall can expand to form a bench or a barbecue. It might flow up, into an arch for a garden gate and then down into a low wall. Finally, it can become stairs and flow back into the foundation. An adobe wall can become all these things provided, that in some way, it is always protected from excessive direct assault by moisture. Thus, though the flowing rhythms of the wall, the building will grow right out the landscape.



## Doors

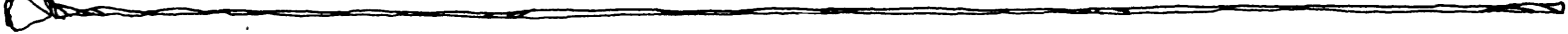

Structural considerations require than openings in adobe walls be infrequent and carefully considered. In order to realize the connection between indoors and outdoors, visual and physical transgression must take place through the walls. Doors are the elements through which one can physically pass.

The openings created for doors in an adobe building point out one of the best features of adobe construction - the mass of the material. The opening itself becomes an entire transition zone due to the thickness of the wall. Early builders, aware of this experience, used the thickness of the wall to its greatest advantage. Doors were placed inside the opening, so that the thick wall

extending overhead protected the waiting visitor from the weather. On the inside, the walls were splayed back so that when the door was opened, light would penetrate further.

Where the maintenance of privacy was important, such as at a home's main entrance, solid wooden doors were used. But, in areas where maximum privacy is not required, light penetration is needed, and a visible connection with the outdoors is desired, glass paned doors were used. Glass doors were most commonly found between common living spaces and the courtyard, or, in second floor rooms which abutted a balcony. These doors allow both visual and physical transgression between indoors and outdoors.

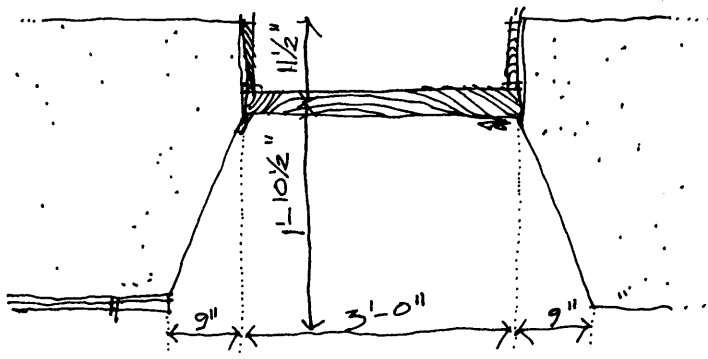
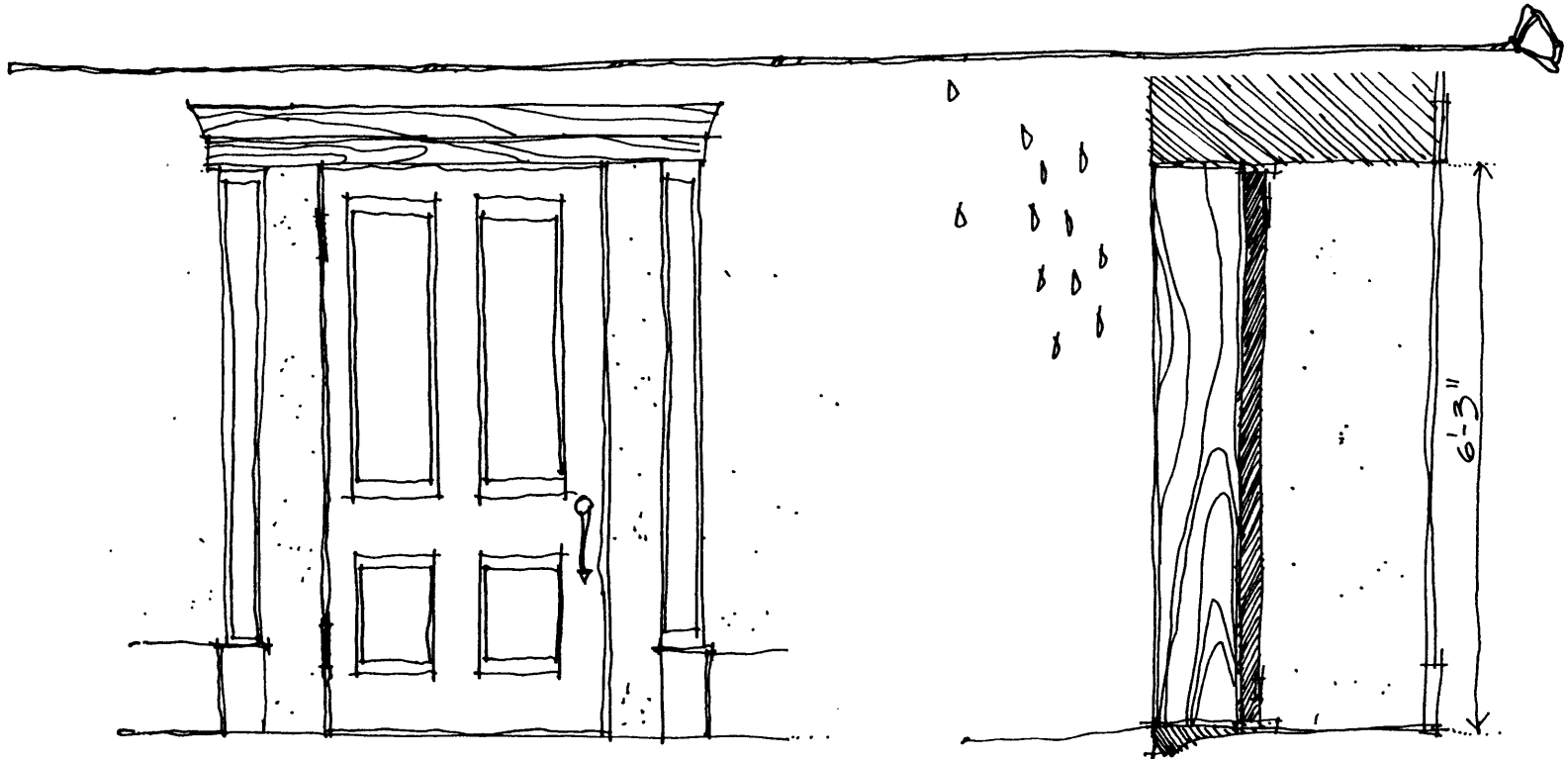

SANCHEZ ADOBE  
SAN PEDRO  
SET IN DOORS



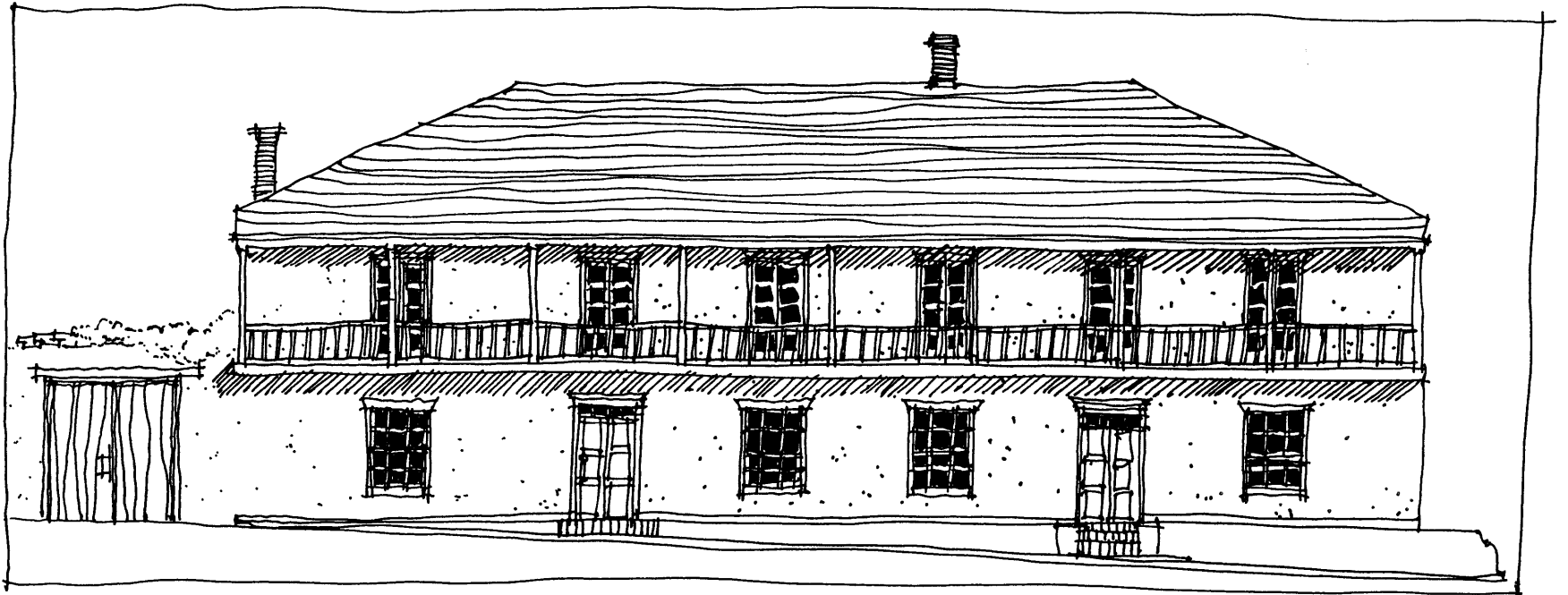
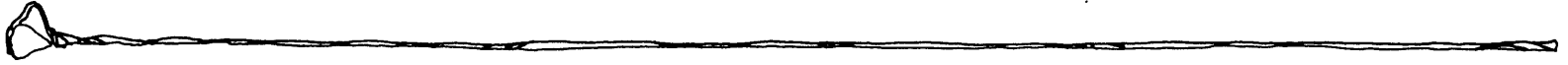

CASA AMESTI: GLASS DOORS



## Windows

The interiors of adobe buildings are often dark and dank. Structural requirements prevent the punching out of extensive glazed areas. Additionally, corredores and deep overhangs prevent excessive direct sunlight from reaching these few windows.

In order to maximize sunlight, glazing, in a thick wood casement, was placed flush with the exterior wall. The interior would splay back dramatically in order to facilitate light penetration. The deep interior reveal might be paneled, thus forming a window seat or sort of bay. Like a doorway, the deep reveal of the window was a transition zone between the interior and exterior.

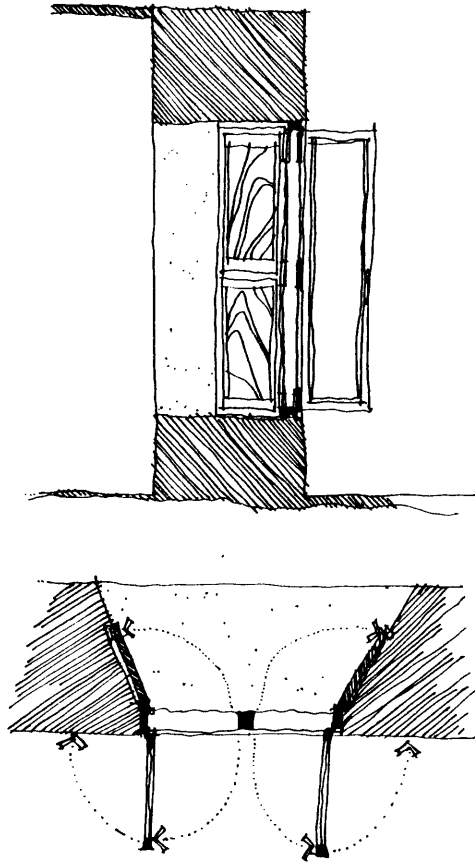

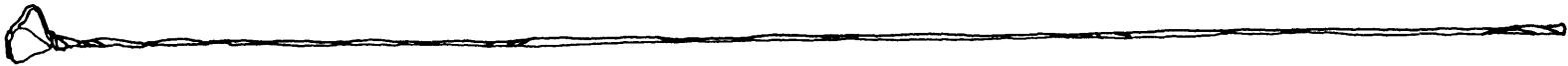

The earliest glazed windows were casements which could open up all the way. Interior to the windows were wooden shutters which opened inwards. In the mid eighteenth century, it became stylish to use yankee 6 over 6 windows in adobe construction. This is the window most commonly seen today in historic buildings. Contemporary construction might want to reintroduce the cheaper hinged window as this style allows maximum air circulation.

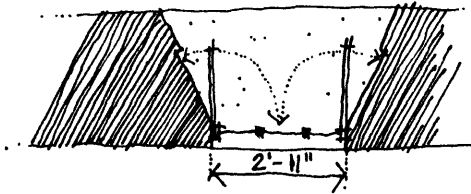
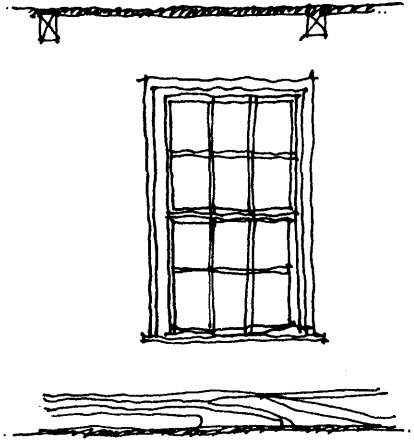
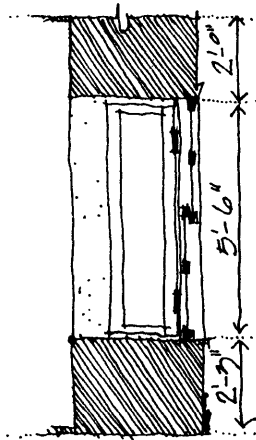

LARKIN HOUSE  
6 OVER 6 SASH WINDOWS



## Balconies

With the advent of two story adobe construction, balconies became popular features. Like the corredor, balconies initially served as circulation space and were accessed by an exterior stair. They too protected the adobe wall from rain while extending the protected living space. As stairs were moved to the interior, balconies became semi-private outdoor space for upper level inhabitants.

Usually made of redwood, balconies were of three distinct types. The first, and most common, had supporting posts from the ground to the roof. The second was a cantilevered balcony with posts supporting the roof. The third, and most rare was a cantilevered balcony and roof. It had no supporting posts.

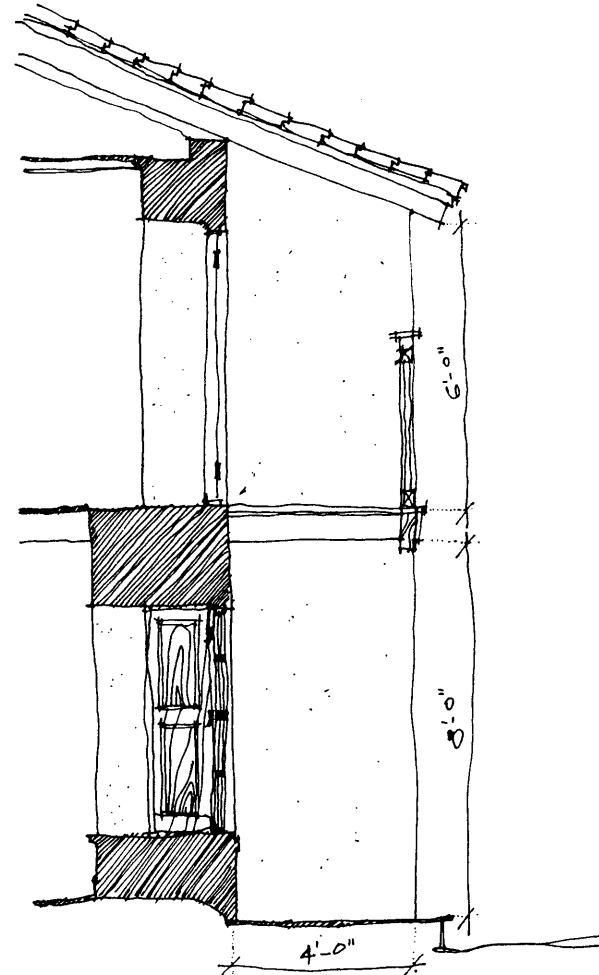

CASA SOBRANES  
CANTILEVERED BALCONY



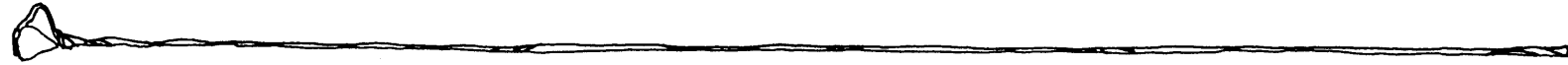

Practically all balconies had closed ends of wide vertical boarding or simple lattice work which gave more privacy and partial wind protection. Additionally, balconies almost always sported picket railings which would further filter the light traveling beyond the balcony edge.

In contemporary construction it is possible to open up an adobe wall and extend the balcony into what was previously the building interior. The resulting closure between the balcony and interior space would have to be lightly framed for load considerations. But a light frame allows more fenestration which would admit more light to the building's interior.

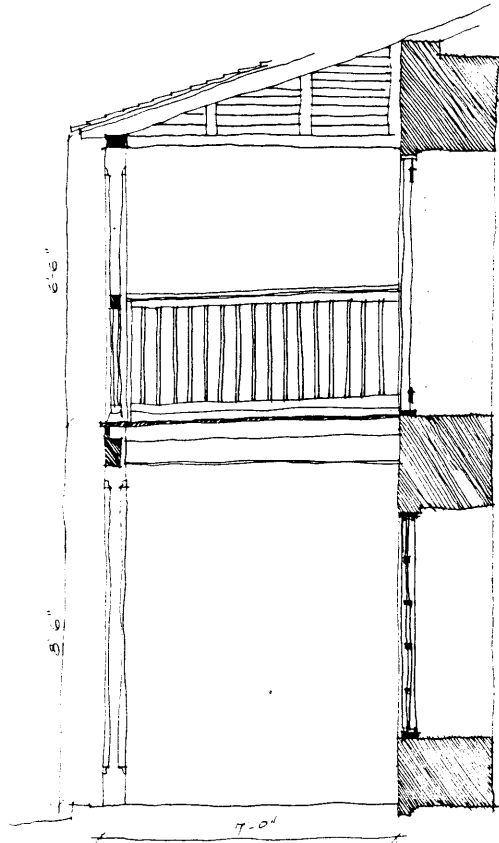

BLUE WING TAVERN • SONOMA  
SUPPORTED BALCONY



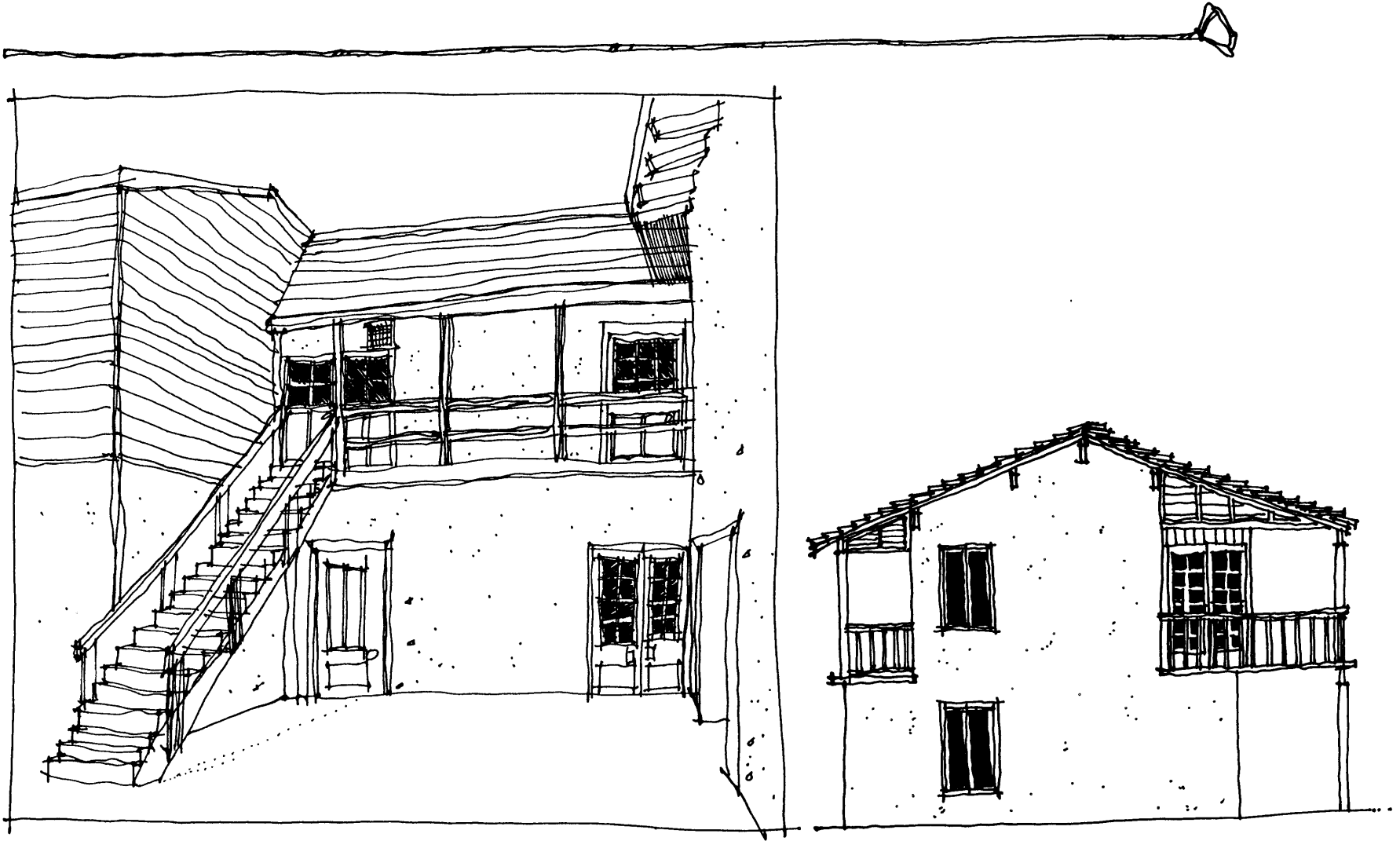

STEVENSON HOUSE  
EXTERIOR STAIRS

EXTENDED BALCONY # PROPOSAL



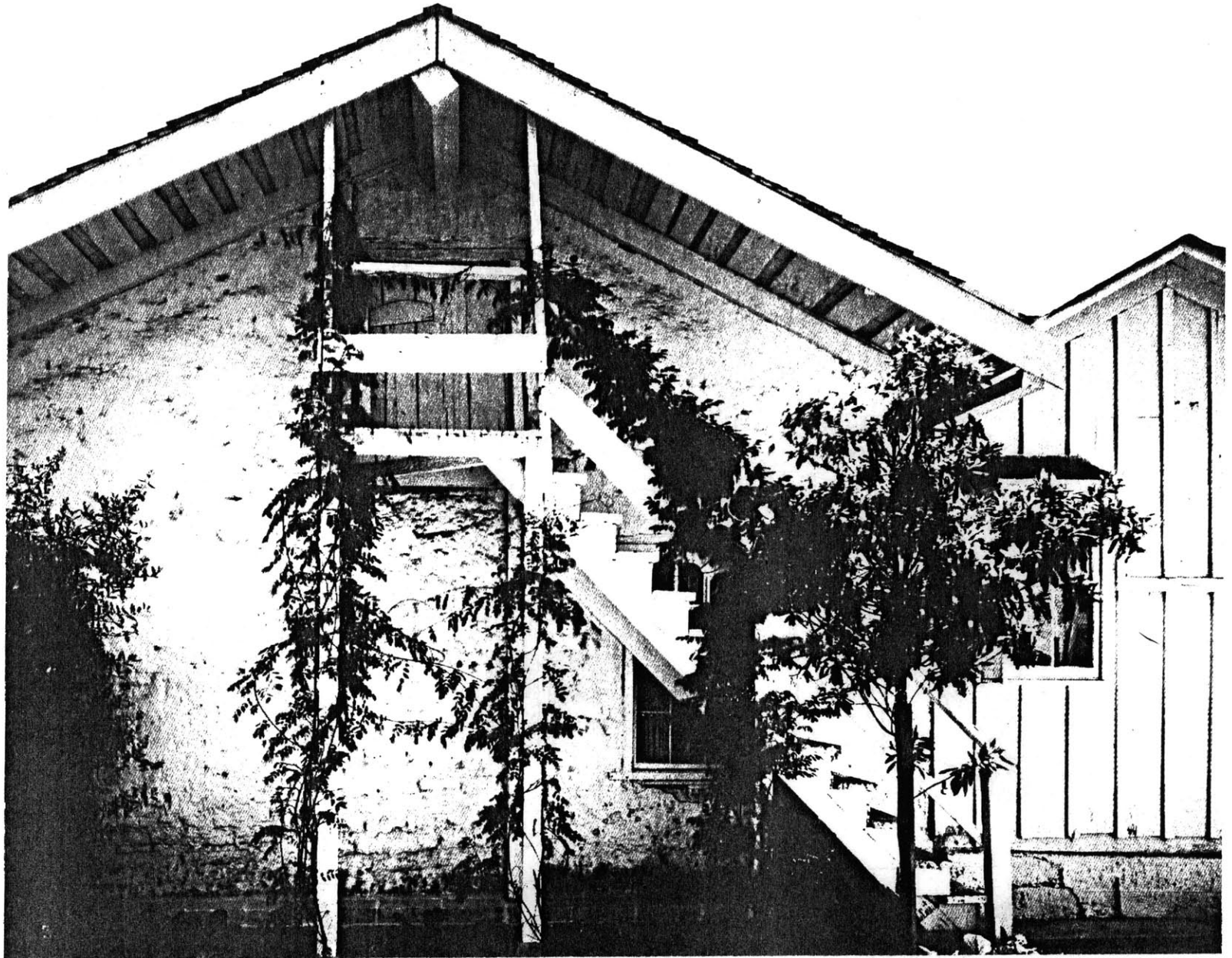

CASA FERRANO



## INTERIOR DEFINITION

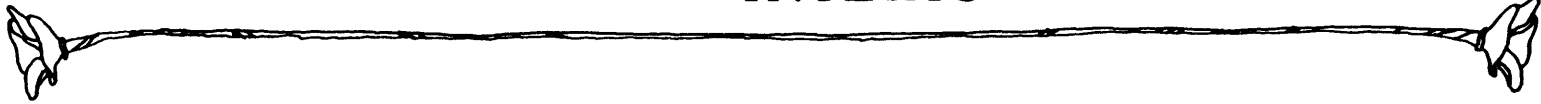

It can be the small design moves which humanize and personalize a building. With the building successfully placed on the site, its architectural elements defined, and the relationship between indoors and outdoors forged; it is time to understand those elements which embellish an adobe structure, and expand the role of elements already discussed.



## Thick Walls

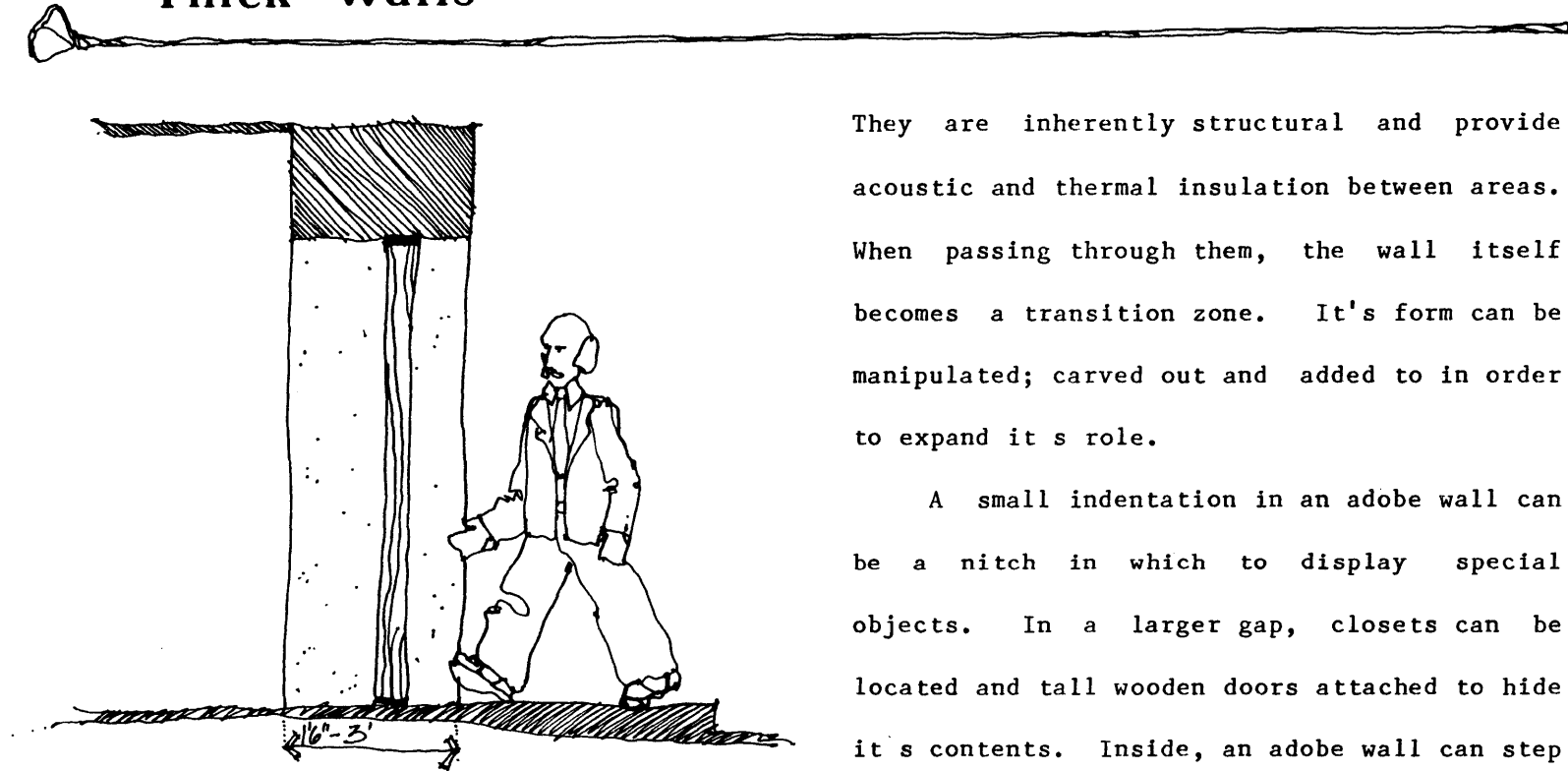

THICK WALL

Thick adobe walls exude feelings of heartiness and are one of the most enduring features of an adobe building. Usually, plastered, they are soft and cool to touch.

They are inherently structural and provide acoustic and thermal insulation between areas. When passing through them, the wall itself becomes a transition zone. It's form can be manipulated; carved out and added to in order to expand its role.

A small indentation in an adobe wall can be a niche in which to display special objects. In a larger gap, closets can be located and tall wooden doors attached to hide its contents. Inside, an adobe wall can step down to form a counter. Step it down a little farther, widen its base and a seat is created. Incremental subtraction will produce steps until finally, the wall dissolves into the floor.



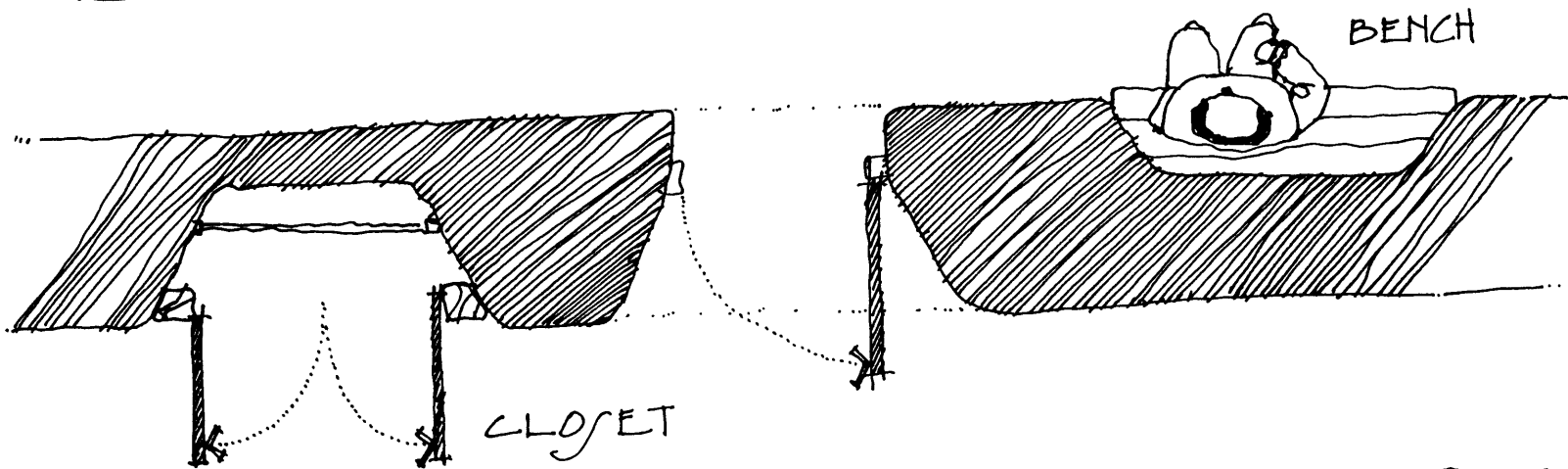
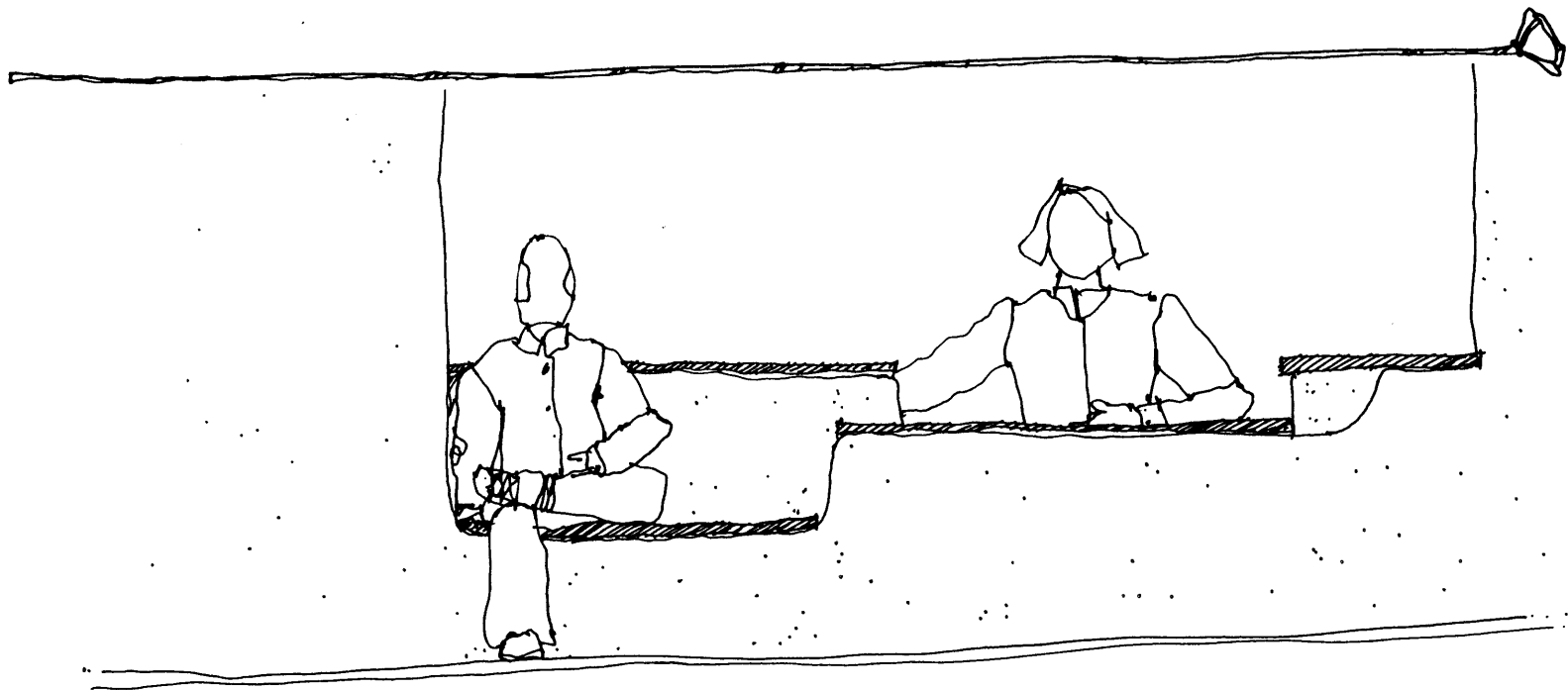

## Flooring

---

Historically, the floor of adobe structures evolved from packed earth, to large, "padre" style tiles with the texture of well burned brick. Later, wood floors, composed of tongue and grooved planks between 6" and 12" in width were laid. Common to all these flooring materials was their softness which would cause the material to wear down and reflect use through the years.

In contemporary construction, it is important to invest in wooden or tile floors. The use of any material less natural would deny the structures connection with the earth on the plane upon which it is most crucial to emphasize and clarify this relationship.



## Strategic Wood Location

California adobes differ most dramatically from their south-west cousins through their increased use of wood. California has more precipitation than the south-west, necessitating increased protection to the fragile adobe walls. Fortunately, extensive groves of California Redwoods, offered a material which could be used to form protective barriers such as roof overhangs, balconies, and corredores. The easy availability of redwood also offered the opportunity of embellishing the home with wood trim and paneling in strategic locations.

As previously mentioned, homes boasted thick redwood plank floors, interior and

exterior redwood trim. Window reveals were lined with paneling to create warmer window seats while cool air was blocked with redwood shutters. Stairs were made of redwood as were balcony columns, railings and the entire roof structure. Wood was strategically located where its warmth and tactile qualities could be best appreciated.



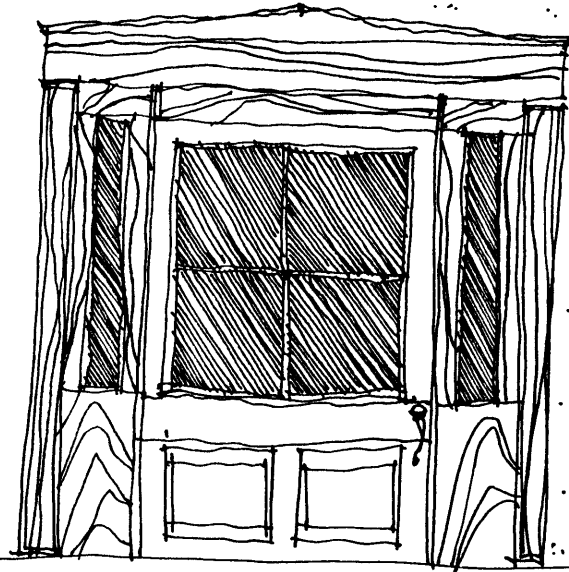
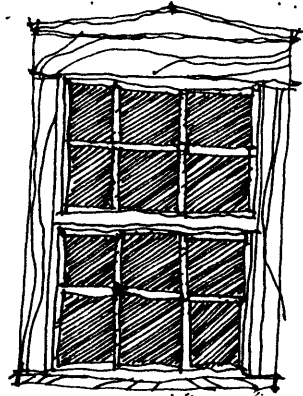
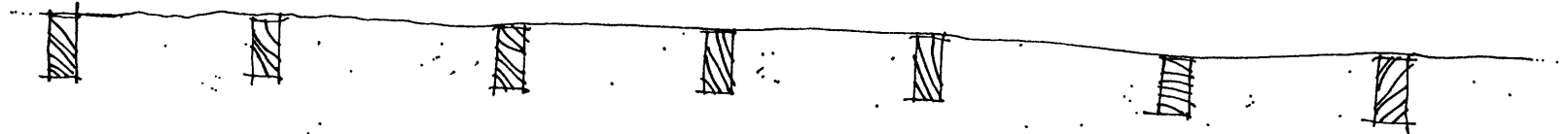
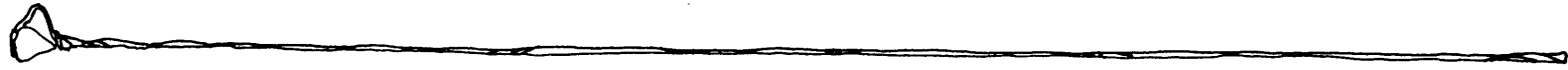

CHILE'S ADOBE  
WOOD AROUND DOORS AND WINDOWS



## Kitchen and Bathroom

During the colonial era, the kitchen and bath were not incorporated into the main house. Lack of modern technology and sanitation systems necessitated their isolation. Of course contemporary living demands their integration into the house. Consequently, their relationship with the rest of the house remains to be defined.

Most of the cooking was traditionally done out of doors. In California, during much of the year, this is still true through the use of the barbecue. Additionally, entertaining and family gatherings are often informal. Guests and family alike congregate in the kitchen to lend a hand. To satisfy its many roles, the kitchen should be located

near the living room and adjacent to the courtyard. This location will facilitate the flow of activity between these spaces. It should be a sunny, cheerful place, large enough to hold a table and chairs. In this manner, the kitchen can become an intimate gathering area for both family and friends.

The bathroom, on the other hand, should be located in a secluded, private area of the house. It should be easily accessible from the living room but not open directly on it. And despite its modern plumbing fixtures, it can gracefully fit into the adobe home through an extensive use of tile and perhaps a sunken tub.



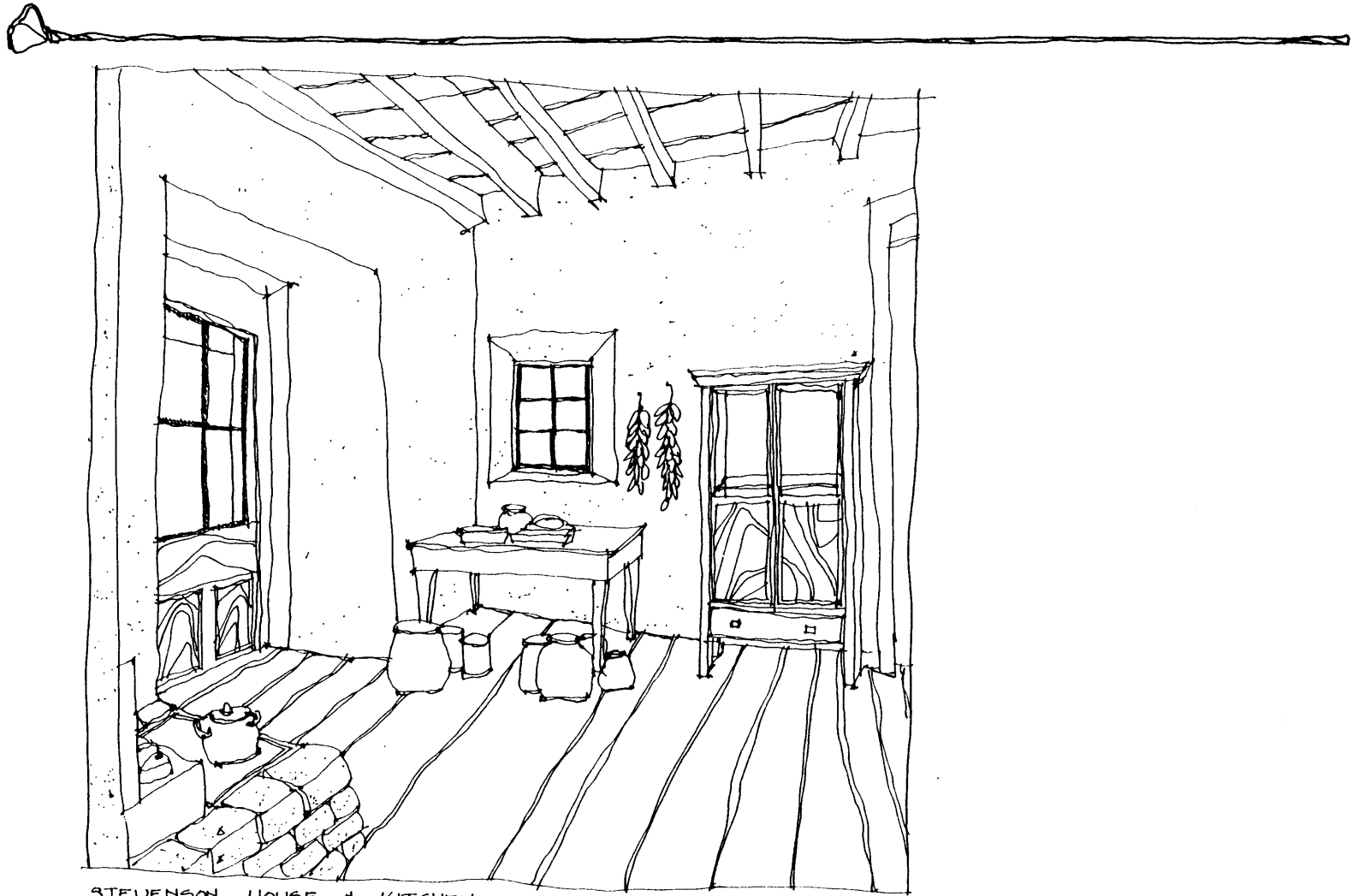

STEVENSON HOUSE # KITCHEN



## EXTERIOR DEFINITION

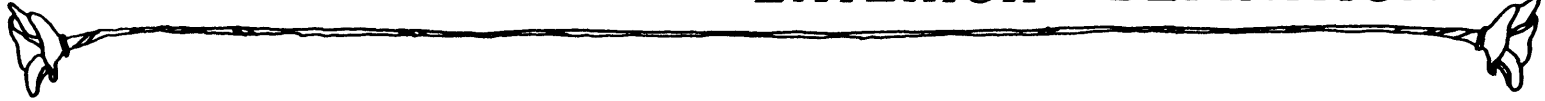

Eventually, after the relationship between the indoors and outdoors has been defined, and either before or after interior details have been decided on, it becomes time to add exterior details. These elements will help to make special outdoor spaces as complete as any found indoors.



## Continuous Flooring

---

plane, the flow between indoors and outdoors can be emphasized through the use of a common flooring material. Traditional, large, soft padre tiles can be laid indoors and outdoors. Or, in view of the popularity of the outdoor deck in California, a wood floor could extend across both areas.

Traditionally, however, the differences between territories were emphasized by using a different flooring material in each space. The sala was surfaced with wide redwood planks while the corredor and patio were covered with tile. This is the appropriate response when it is desired to be less literal concerning the linkage of spaces.

Earlier we explored how plan, common openings and vertical connections can forge a link between two spaces. In the horizontal



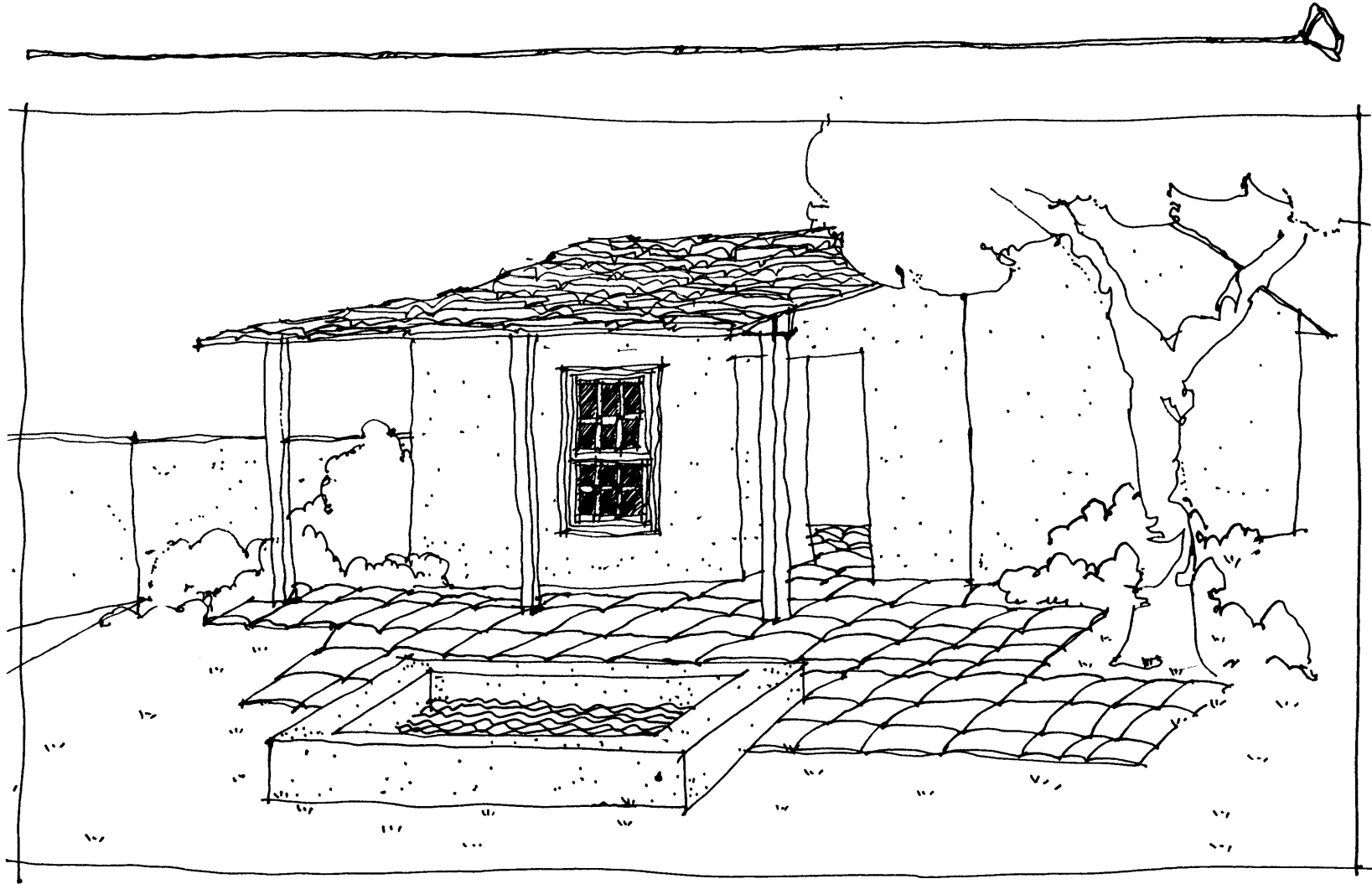

SOFT TILE TO CONNECT INTERIOR AND EXTERIOR \* PROPOSAL



## Soft Space

Exterior built edges can be tempered and their connection with the environment softened when elements such as plants and water are incorporated. The connection between the garden wall and the ground will be buried when shrubbery is planted in beds or in tubs along the courtyard perimeter. A surfaced area which can become warm on summer days will cool down with the addition of a fountain. And the garden will grow right over the house when climbing, flowering plants such as bouganvilla and wisteria cover the corredor and balcony.



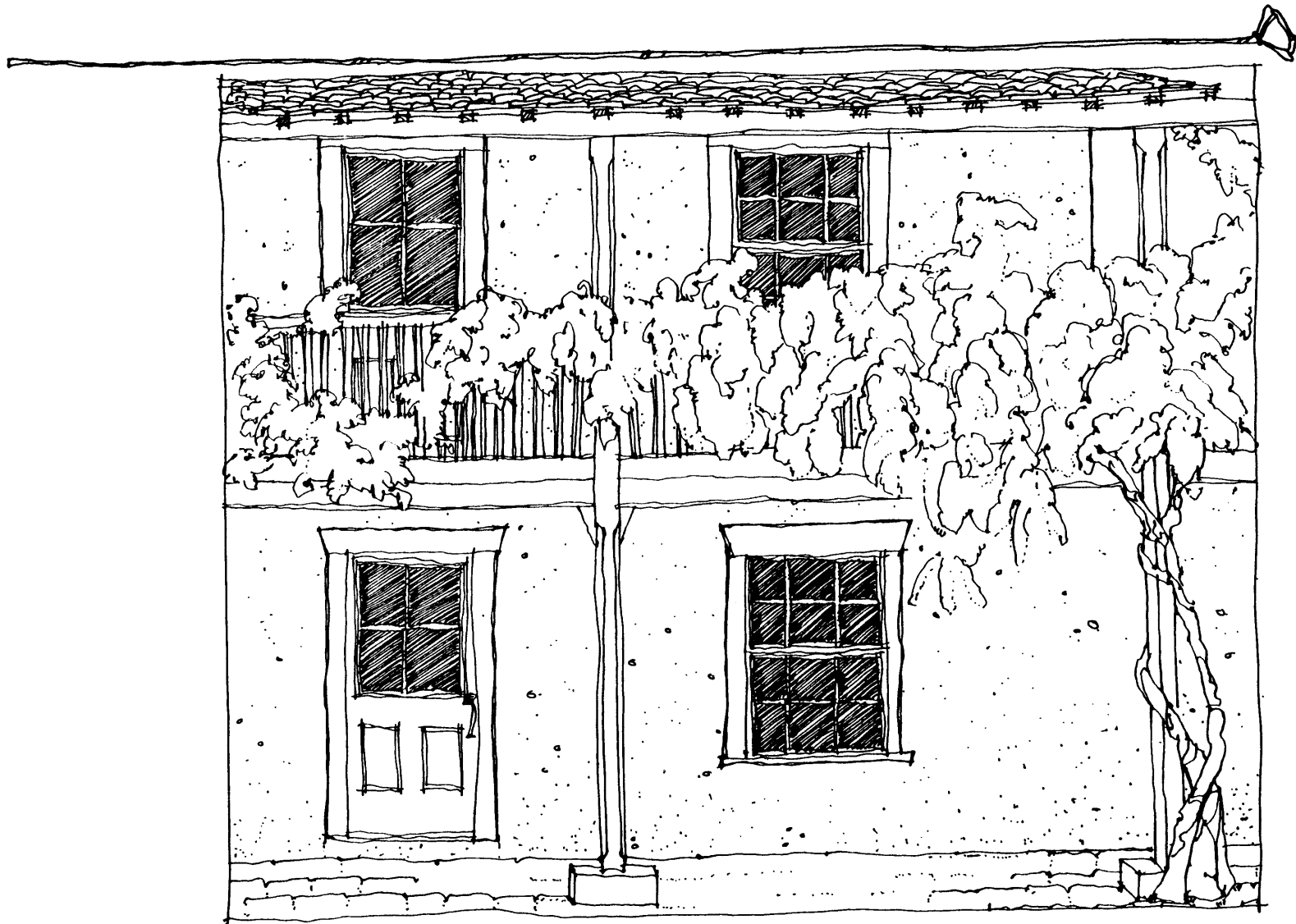

BLUE WING CAFE # CLIMBING PLANTS



## Filtered Light



PETALUMA ADOBE

The afternoon light in California can be very harsh, and it is desirable to create special zones out of doors which offer filtered light.

A trellis covered with a flowering plant can become a special outdoor room if it has adequate dimensions. It can also act as a covered path within the courtyard, connecting the garden gate with the corridor.

A carefully located, indigenous deciduous tree will filter summer light while allowing winter light to penetrate. Likewise, canvas awnings over a wooden frame offer summer shade and winter light when they are removed.

Finally, the ever present picket fence found on balconies or defining property lines cause a delightful play of light and certainly a satisfying tackity, tackity, tack when a stick is pulled across it.





CASA SOBERANES



## Colors

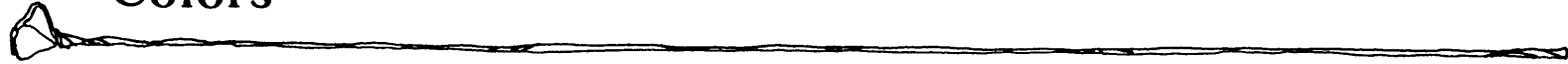

integrating them into the landscape. The redwood roof darkens, its color mellowing to match the brown of the hills. Eventually, it becomes covered with moss, whose green color is the same as the oak trees.

The adobe walls are periodically whitewashed to form a protective coating. Historically, the lime plaster remained white or was tinted cream or pink to suggest warmth. Likewise, interior woodwork was lightly stained in order to lighten the interior of the adobe structure.

The repertoire of materials presented here has origins in nature. The materials themselves embody the browns, greys, and olive greens of the landscape. Time itself only serves to deepen and meld them, further

In order to harmonize with the landscape, it is desirable to maintain this soft, warm palette when tinting the adobe and accompanying woodwork.



# DESIGN PROJECT

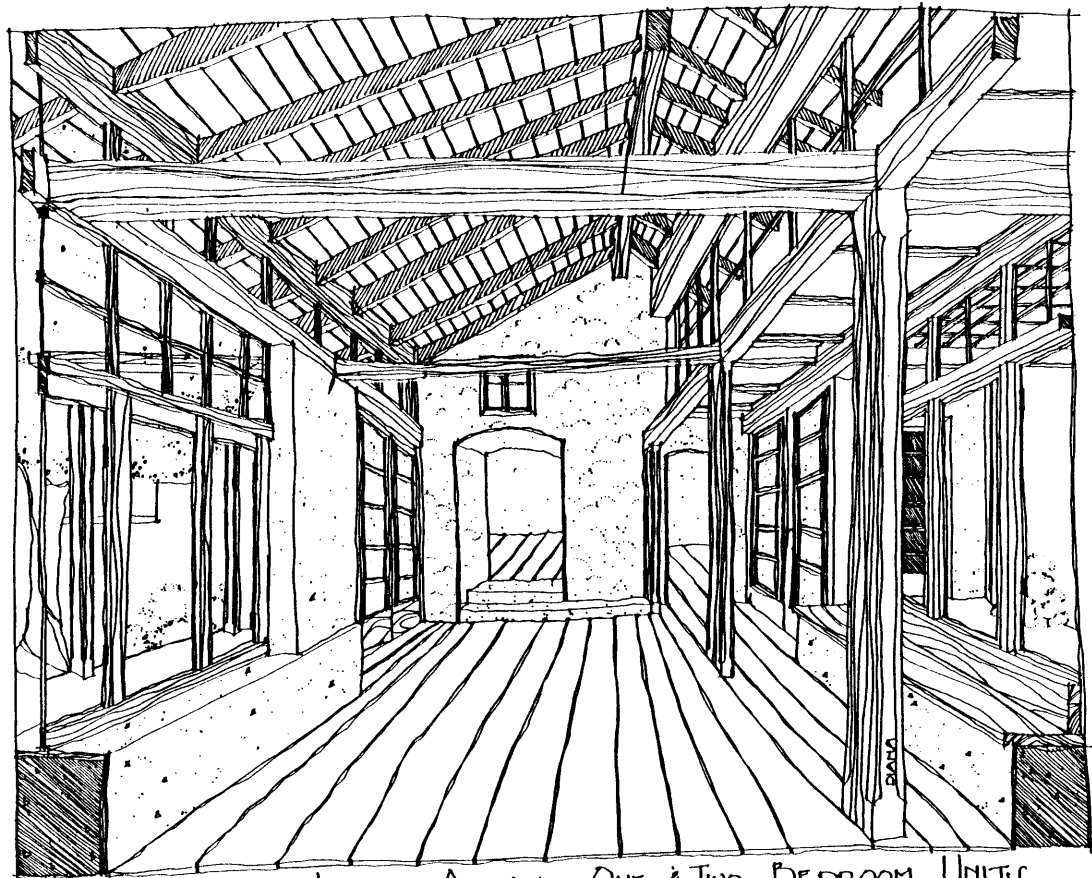

STUDY OF LIVING AREA: ONE & TWO BEDROOM UNITS



# Problem Statement



In order to assess the viability of a design framework, it must be implemented. A designer must struggle with the concepts outlined in solving an actual problem. In doing so the framework will be refined and this process will contribute dynamic, multidimensional qualities which are difficult to realize solely through the process of observation and analysis.

To test this framework, a housing project for the sleepy town of Cotati, California was designed. Located in the Northern California wine country, adjacent to the historic colonial town of Sonoma, Cotati is experiencing growth pangs typical of many California communities. Previously an

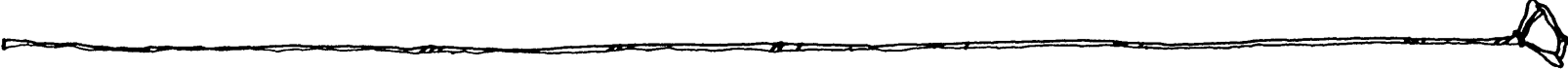

agricultural community; blessed with a beautiful, rolling countryside, suburban growth is exerting pressure to convert it's open fields into densely built housing tracts.

However, in some ways Cotati is unique in it s plight. It s progressive, all women city council truly believes in maintaining the city's rural quality at the expense of developer profits. To quote the Cotati

Design Guidelines:

"Cotati is a rural town, placing high value on both human and environmental amenities. A beautiful tree of humble structure may be considered of greater value to the community than a new structure. Respect for community values should be reflected in architectural style. Designers should be aware that Cotati wishes to promote development with an image different from that of many neighboring communities."

The city council constantly seeks innovative

approaches in the quest to provide attractive, affordable housing. This dedication is exemplified in the city's sponsorship in 1981 to design a \$20,000 house on city donated land.

In addition to a progressive development philosophy, Cotati boasts ideal environmental and climatic conditions for adobe construction. Cotati is located on clay soil from which adobe bricks can be easily manufactured. Additionally, it's long dry summers and mild winters insure the maintenance of the adobe structure provided the walls are adequately protected from rain.

In satisfying a multitude of requirements, Cotati is ideally suited for an adobe building project.





It is the intent of this exercise to design a housing project which offers an alternative to conventional housing types. It should also be sympathetic to the development goals of the community. The design goals stated by the Cotati Design Review which should be met are to:

1. Preserve existing trees.
2. Design simply and honestly with plain materials.
3. Design structures that respond to the local climate. Hot summers require cool outdoor areas, shade for parking and buildings; cool, muddy winters require roof gutters, walkways, and covered porches.
4. Harmonize with existing development through use of similar colors, textures, forms, and landscape materials.

5. Landscape your project so that it fits in with the surrounding area by using indigenous plant types.
6. Landscape plans should include a variety of plant forms including trees, shrubs, groundcovers, vines, and flowering deciduous and evergreen materials.

Additionally, the particulars of the site chosen for development require that the project be integrated with the adjoining creek side path and park. This integration should include an expansion of activities offered along the creek. Finally, the challenge of the project is to maintain a rural atmosphere within the development despite the density of construction.



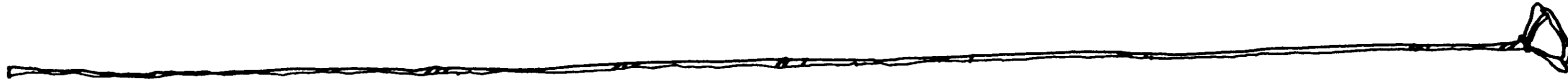

28 attached housing units with carports.  
1 bedroom units: 5 at 700 sq. ft.  
2 bedroom units: 15 at 880 sq. ft.  
3 bedroom units: 8 at 1350 sq. ft.

Recreation Center  
Recreation Building  
25 yard pool  
Tennis Court  
Snack Bar  
Tot Lot  
Playing Field

28 additional parking spots



## Site Analysis

---

The site chosen for the adobe project is located at the far eastern edge of town. Currently the site serves as Cotati's municipal yard and houses maintenance vehicles and materials. The site is bound on three sides by Cotati's neighbor - Rohnert Park, and on the fourth side by the creek, Arroyo de Santa Rosa. Consequently, site access is only from a bridge located roughly at the site's center.

The site's basic orientation is north-south, as is Arroyo de Santa Rosa on the site's western edge. The site's north, east, and south edges are thickly planted with pine trees. Consequently, the site's primary vista is across the creek, towards the west. This is also the direction in which the town lies

and access is gained to the principal freeway leading to San Francisco.

The site itself lies 10' above the creek bed. It is flat with only a four foot variation in elevation. It's vegetation is mostly tall grass. However, a few tall pine trees are scattered across it.

The neighborhood in which the site lies is solely residential. On its west edge, high density, low elevation, attached housing is currently under construction. To the east and south, the site borders the back of a detached single family development. An empty field lays to the north. A ten minute walk along the creek will bring the resident to the Cotati's commercial center.

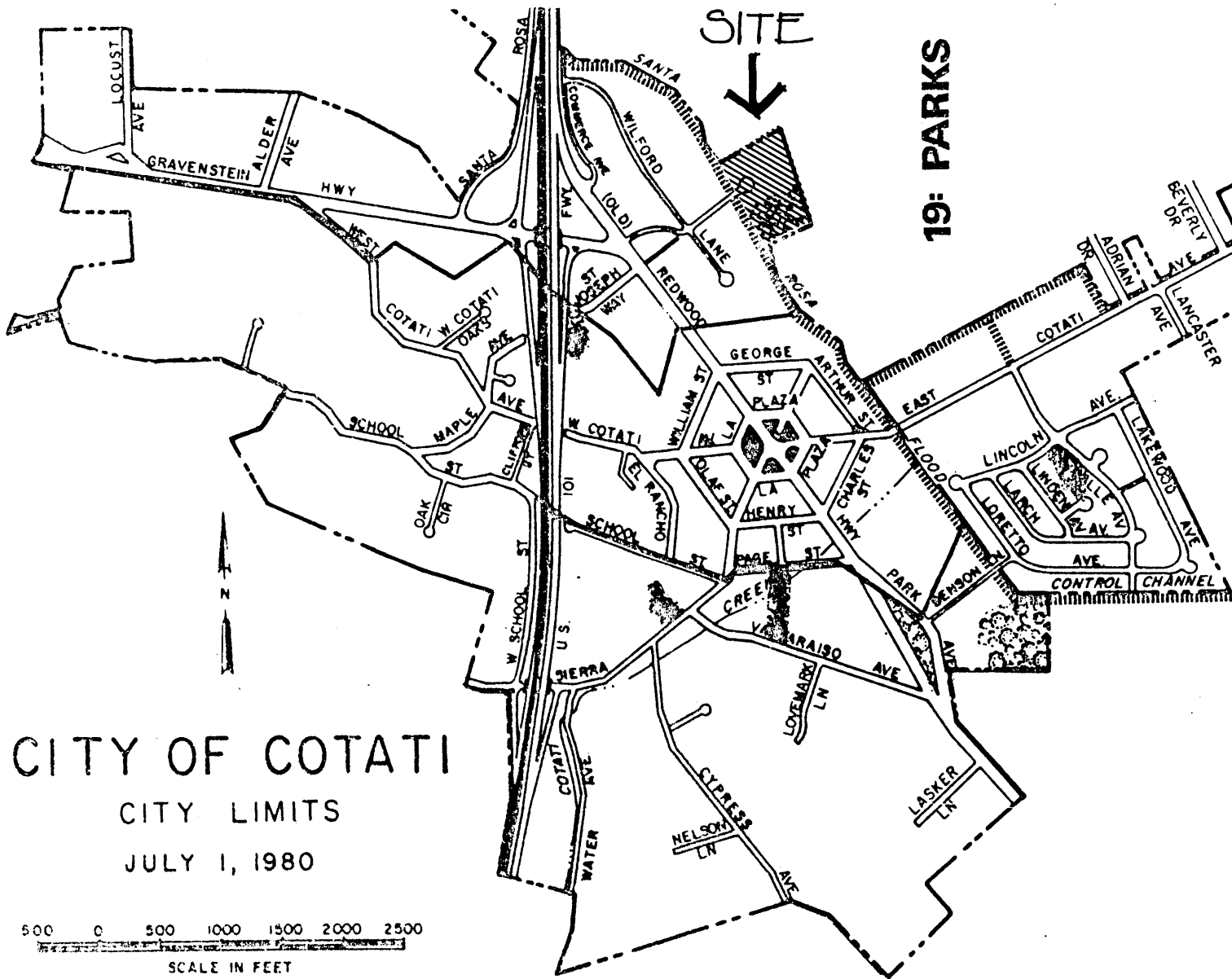

19: PARKS

CITY OF COTATI  
 CITY LIMITS  
 JULY 1, 1980

500 0 500 1000 1500 2000 2500  
 SCALE IN FEET

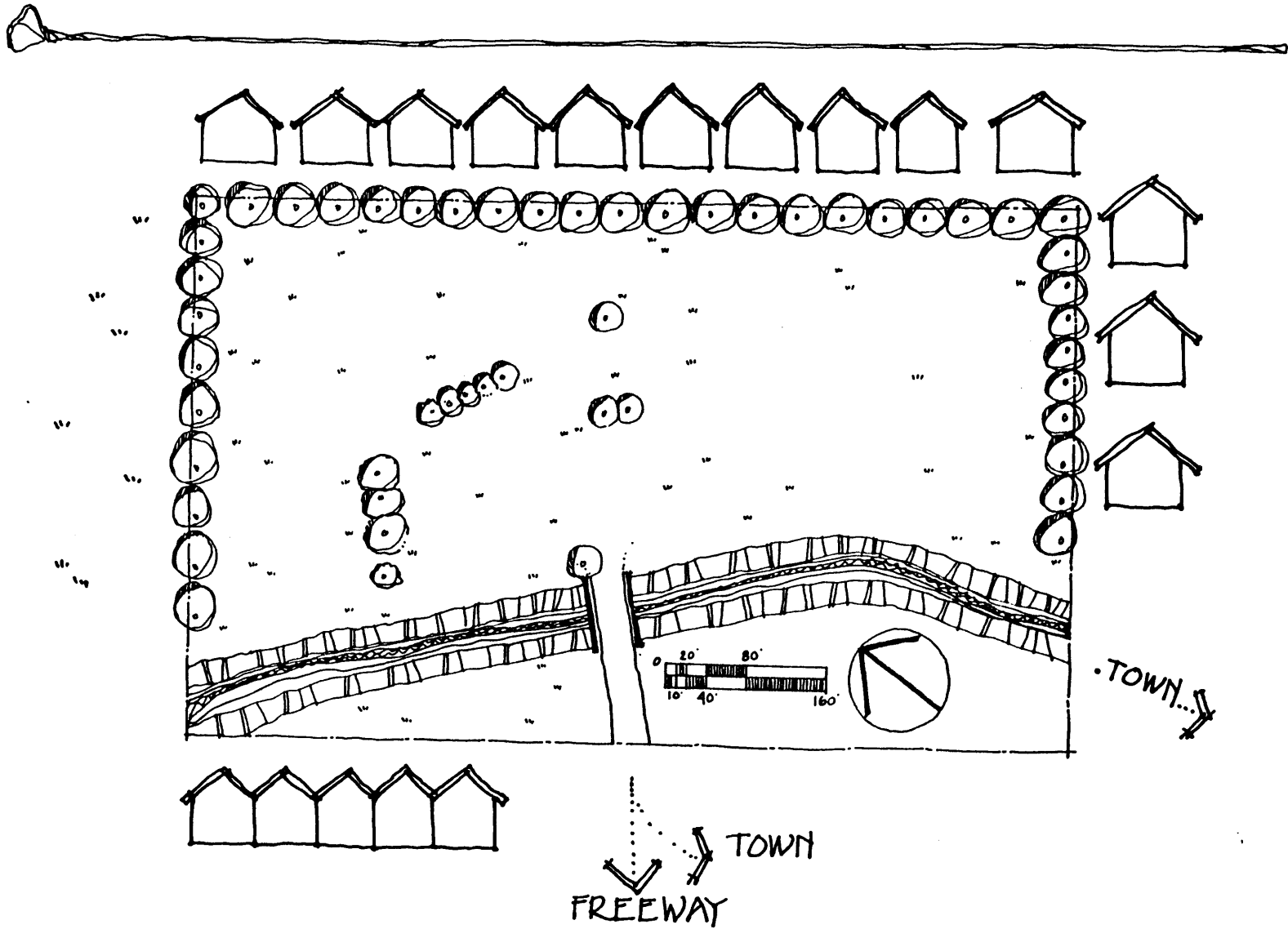

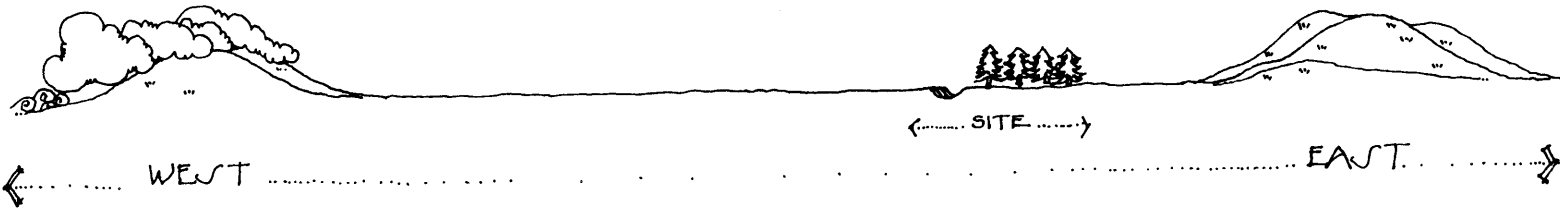
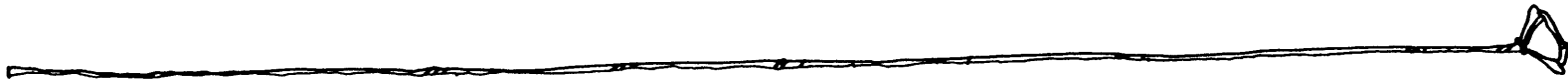

SITE LANDSCAPE ELEMENTS





## *Weather facts*

The plain on which Rohnert Park and Cotati are situated offers a fortunate combination of climate factors. Cool, moist marine air moving in from the ocean moderates temperatures while the low range of hills to the west protects the area from the effects of severe Pacific storms. The coastal range to the east acts as a barrier to the Central Valley heat waves.

Heavy frosts are rare, and while snow may sometimes be glimpsed on the eastern hilltops during midwinter, some ten years have passed since a snowfall last blanketed the plain. Hailstorms are also a rarity here.

Rainfall is concentrated in a six-month period, from October through April, peaking at an average 7.56 inches in January. The cycle of rains usually keeps the winter temperatures above freezing, averaging 38 degrees during the coldest period in December and January. Rainfall intensity averages .40 to .75 inches

per hour, and average total rainfall per year is 27.67 inches.

Relative humidity during winter is an average 77 percent, compared to a 50 percent low in summer. The region's growing season, determined by days per year with temperatures above freezing, is 230 to 260 days.

Winds on the coast become blustery in springtime, but the buffer of hills to the west keeps wind speeds down to a maximum of 4 - 12 mph 49 percent of the time here. Forty-eight percent of the winds travel southeast to southwest, and the chill north-to-northwest winds occur only 14 percent of the time.

Mild springs, with an average temperature of 62 in February, gradually rising to 71 in May, give way to sunny, swimming-pool weather in July, August and September. Outdoor activities may be enjoyed almost year-round in our friendly climate.

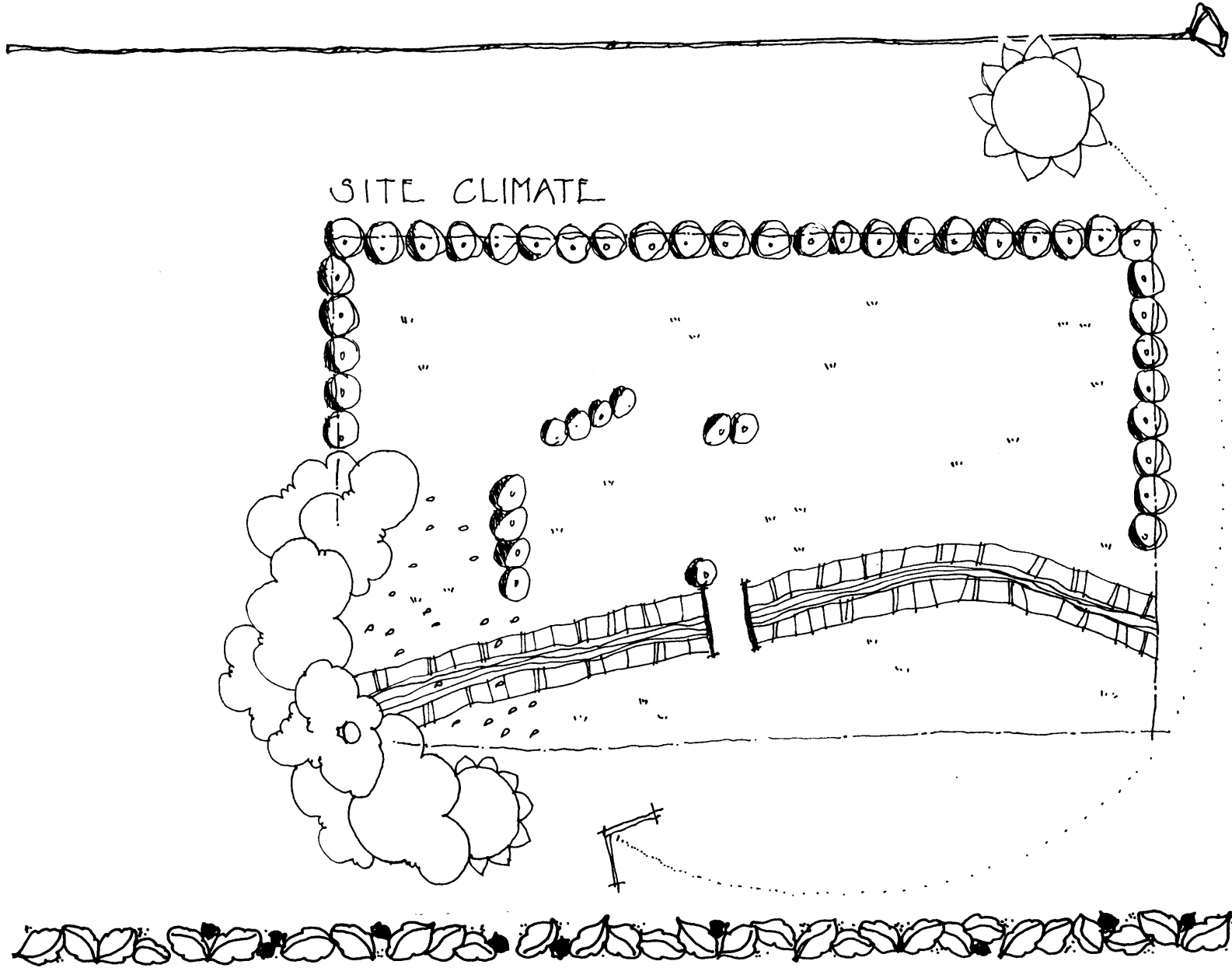

## Site Plan



The spine of the site is the creek and it's adjacent pedestrian promenade. The promenade is energized by the activities which take place along it and in the park. These activities include a playing field, swimming pool, community center, tennis court, tot lot, and trellis's for more intimate interactions.

Flowing directly off the park are the common outdoor areas of the four housing clusters. Privatized from the park with a gentle level change, it is hoped that these common spaces will encourage the interaction of cluster residents and form intimate communities within the greater community.

Each common space is abutted by 6-9 residential units. These courtyard homes sport dual access. Pedestrian access is gained through the common outdoor space. While pedestrian or vehicular access is available on it's street facade.

Primary vehicular traffic flows up from the center to either side of the site's eastern boundary. The residential units are serviced through courts which extend off the main road. In flowing up around the back of the site, vehicular traffic does not come in conflict with the outdoor recreation areas and allows them to flow into each other.



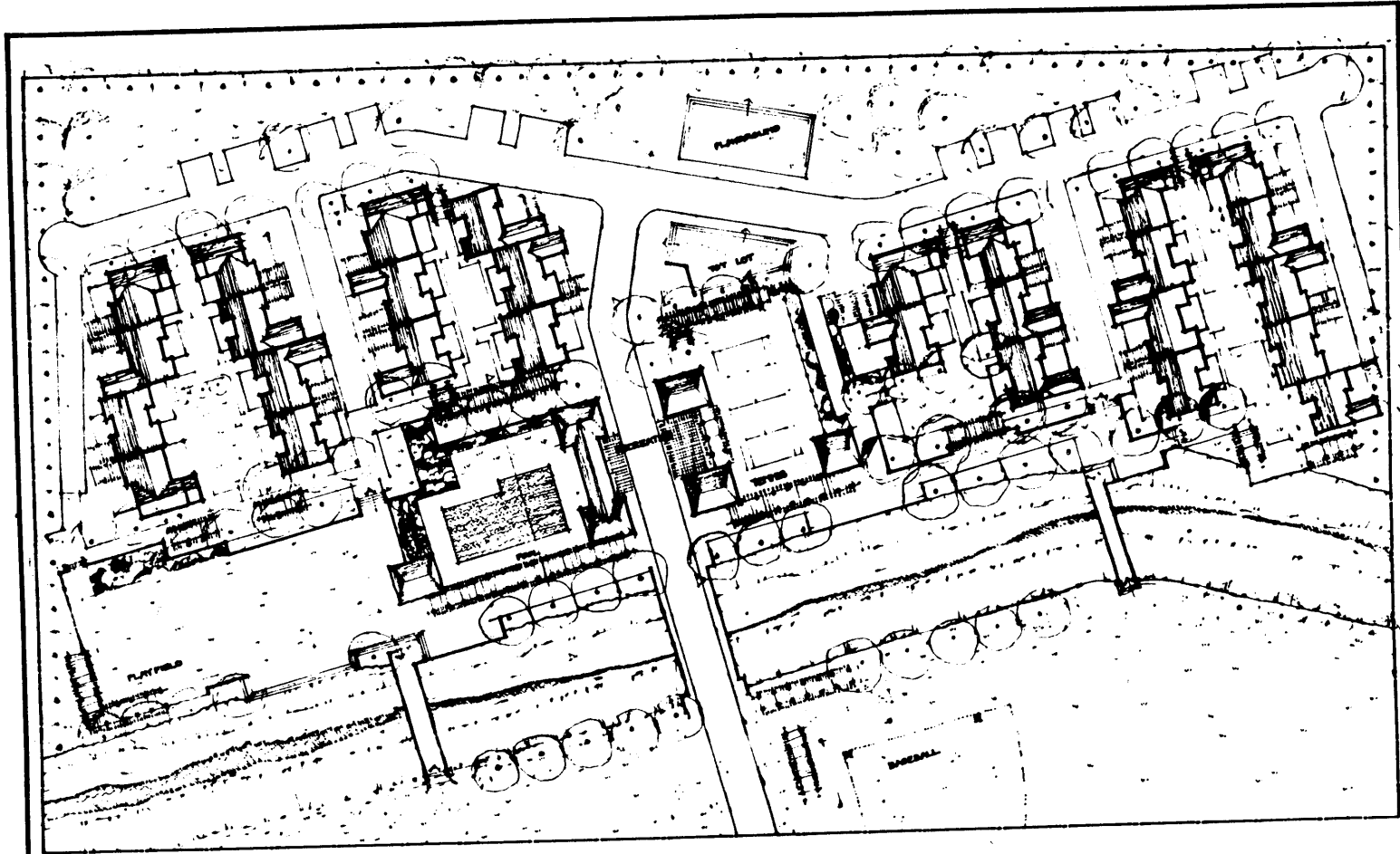

COTATI ADOBE HOUSING

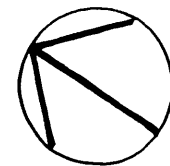

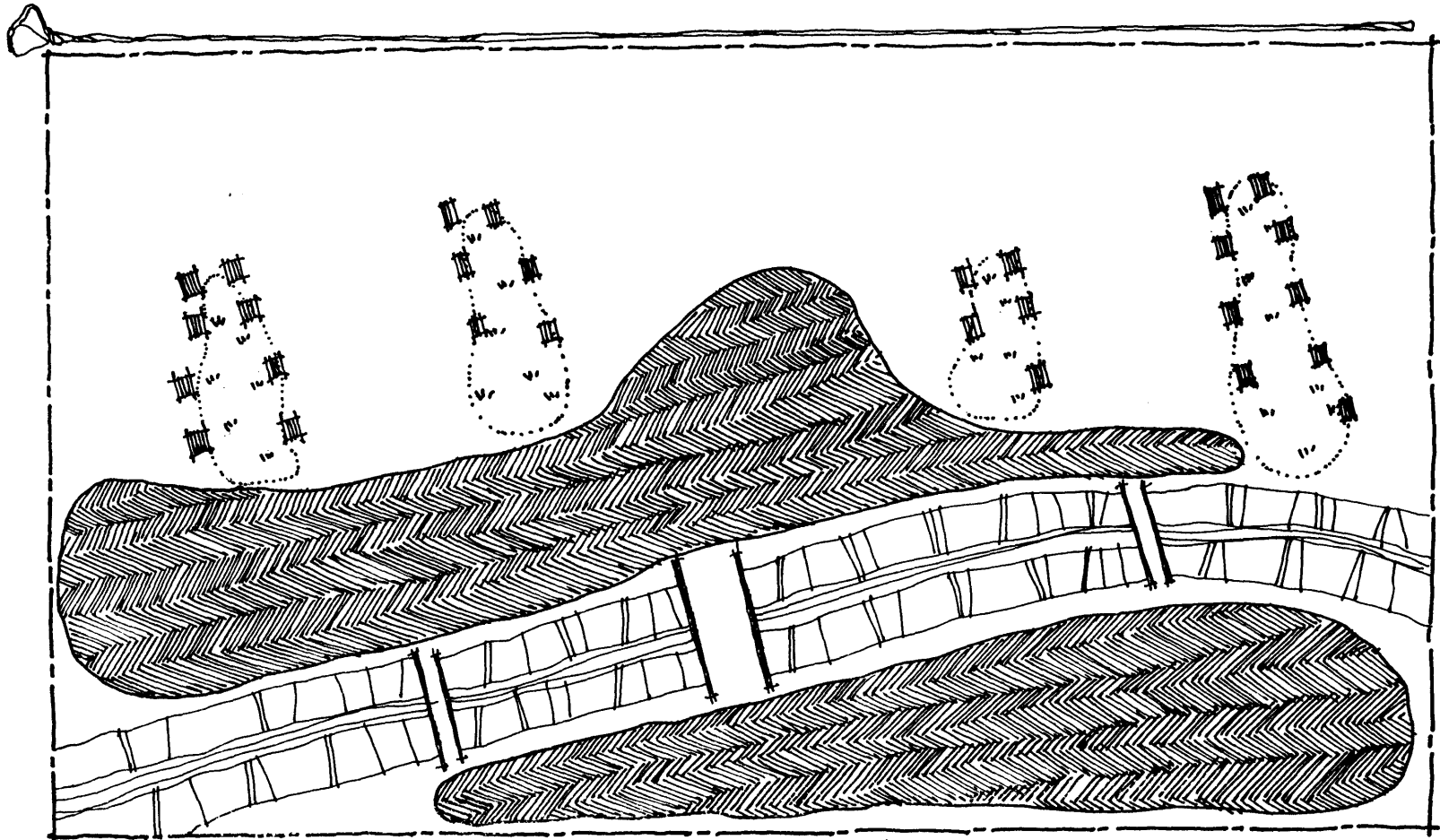

SITE PLAN : HIERARCHY OF OUTDOOR SPACE



PUBLIC PARK

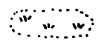

SEMI PUBLIC CLUSTER COMMONS



PRIVATE UNIT COURTYARDS



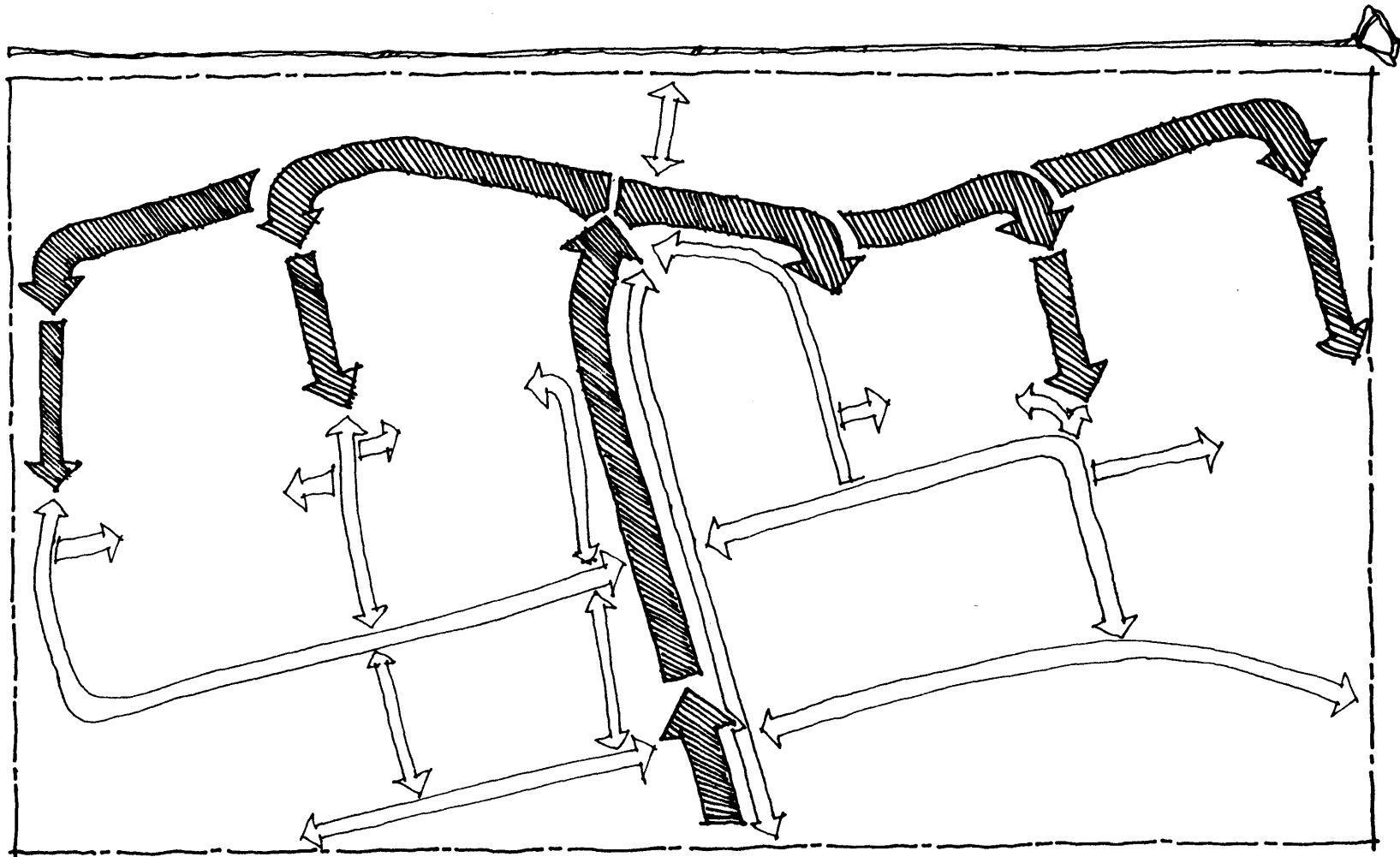

SITE CIRCULATION DIAGRAM



VEHICULAR CIRCULATION

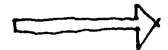

PUBLIC PEDESTRIAN CIRCULATION



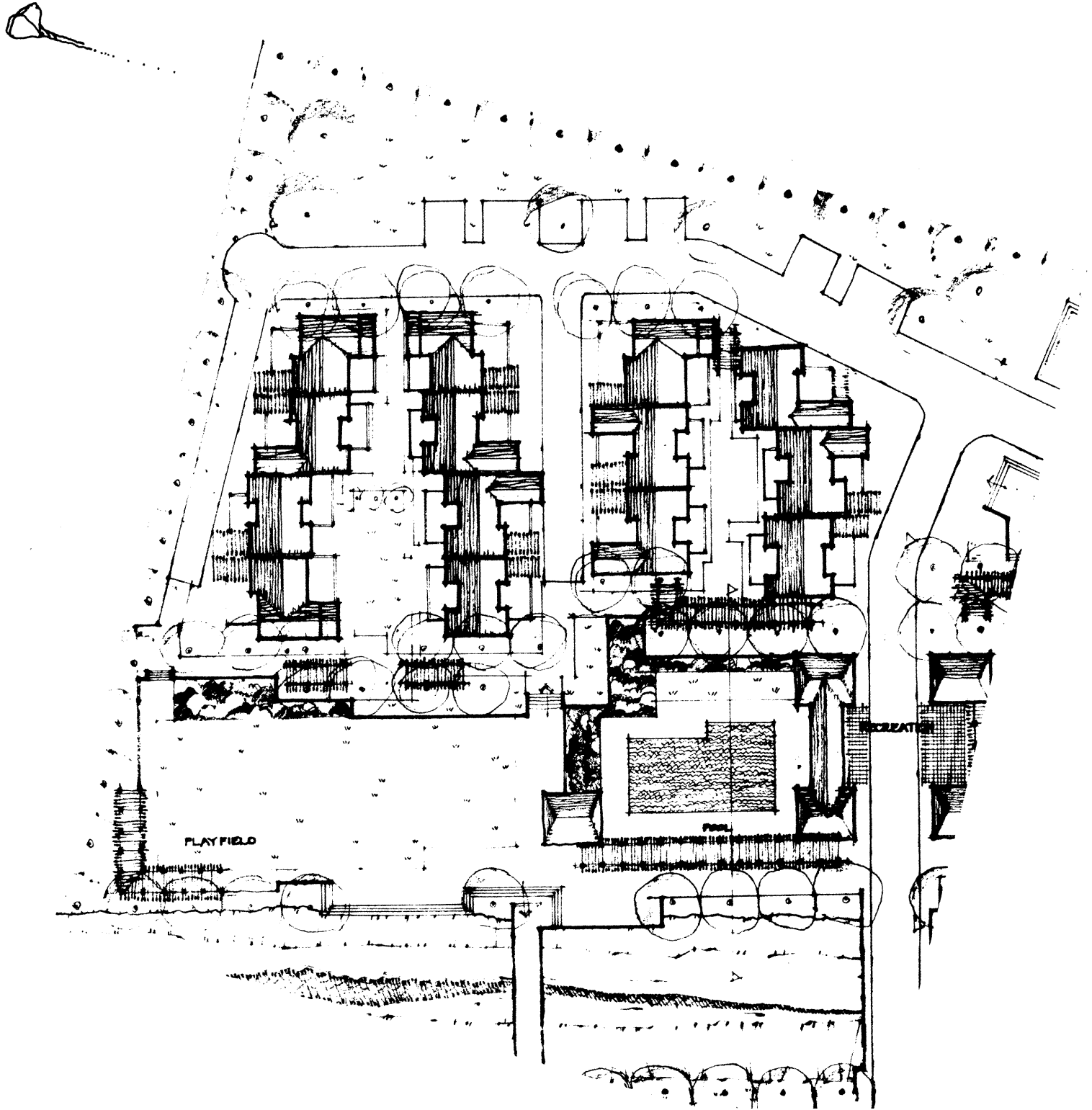

128



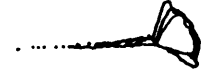

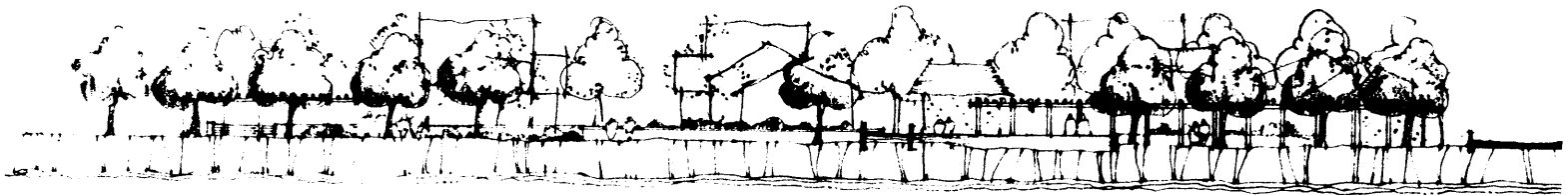

SITE ELEVATION AT CREEK EDGE



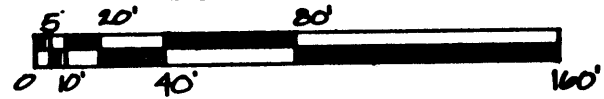
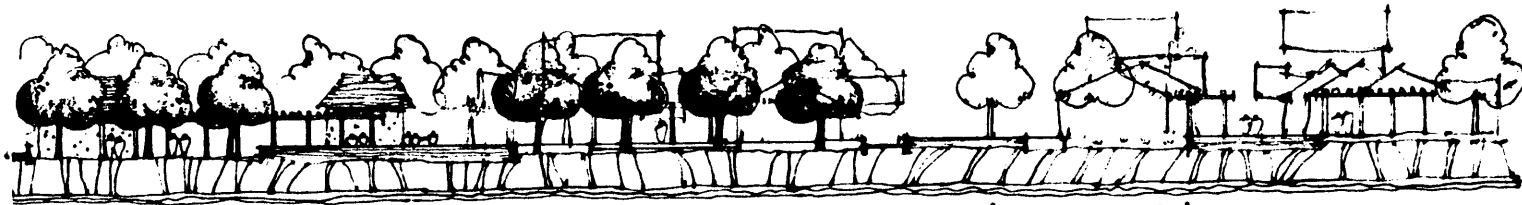
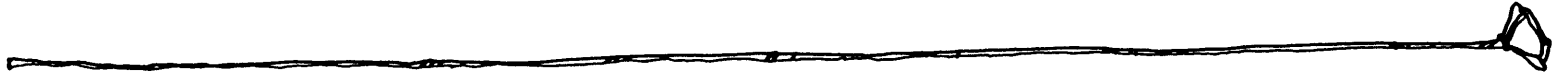

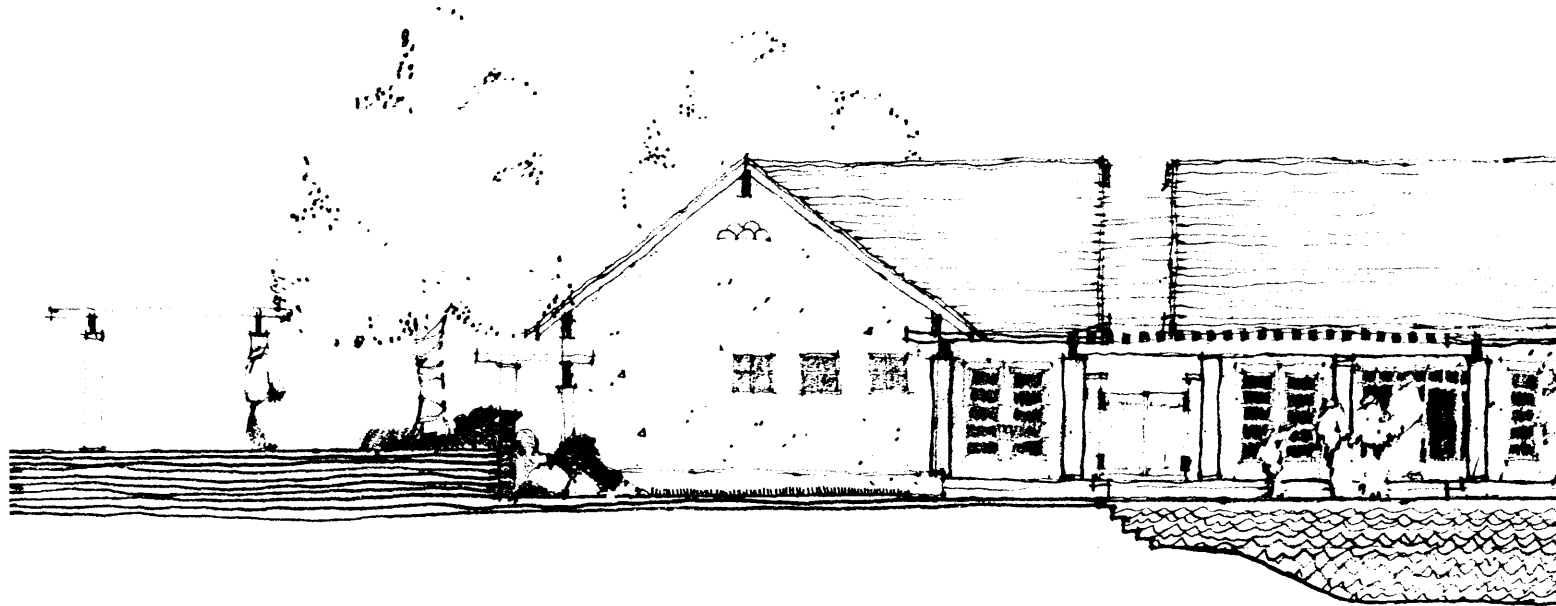
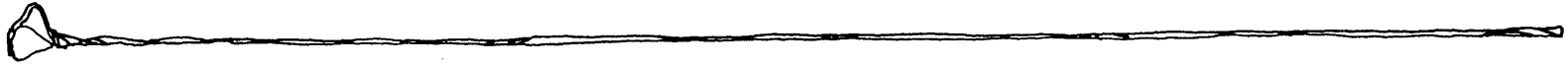

SECTION THROUGH PARK LOOKING TOWARDS



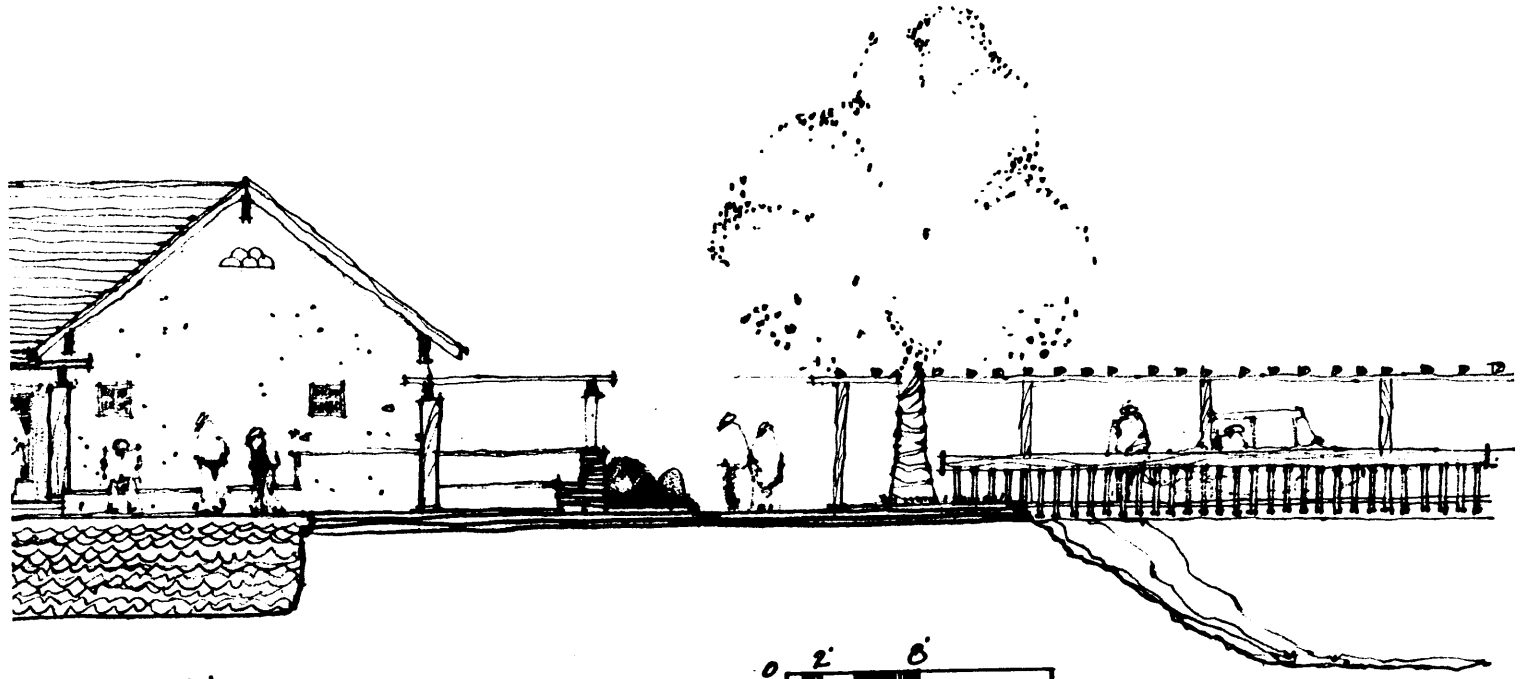

PDDL HOUSE

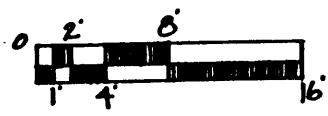

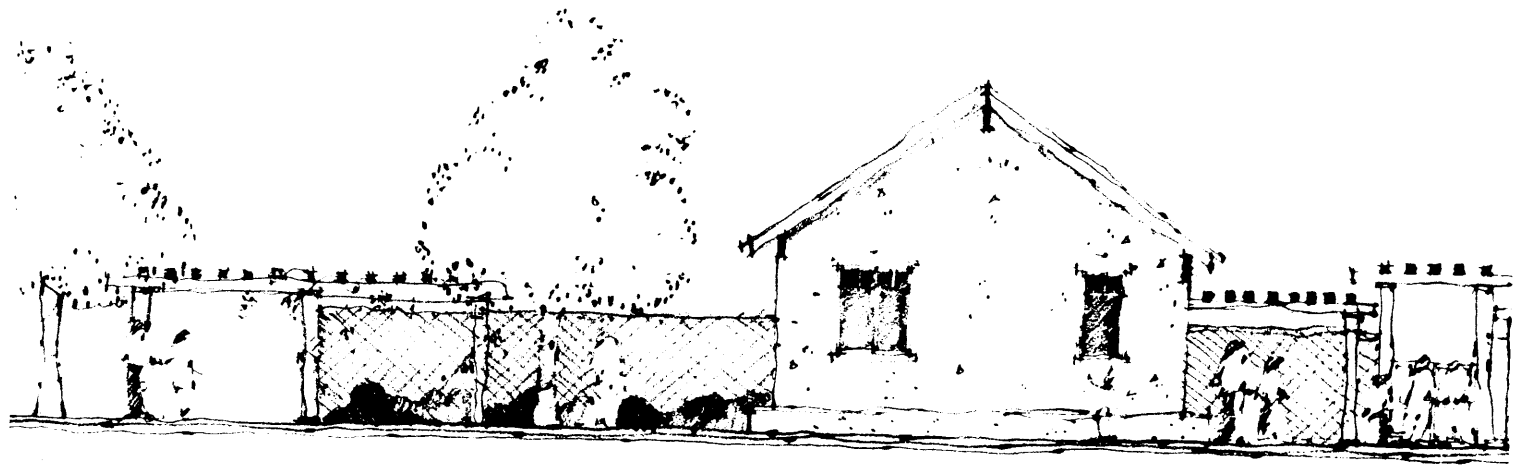
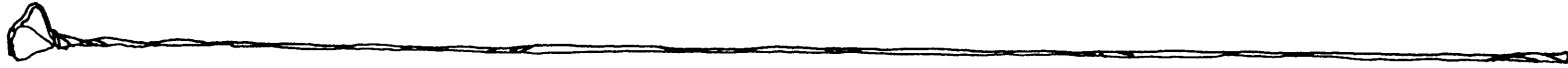

TENNIS CLUB ELEVATION



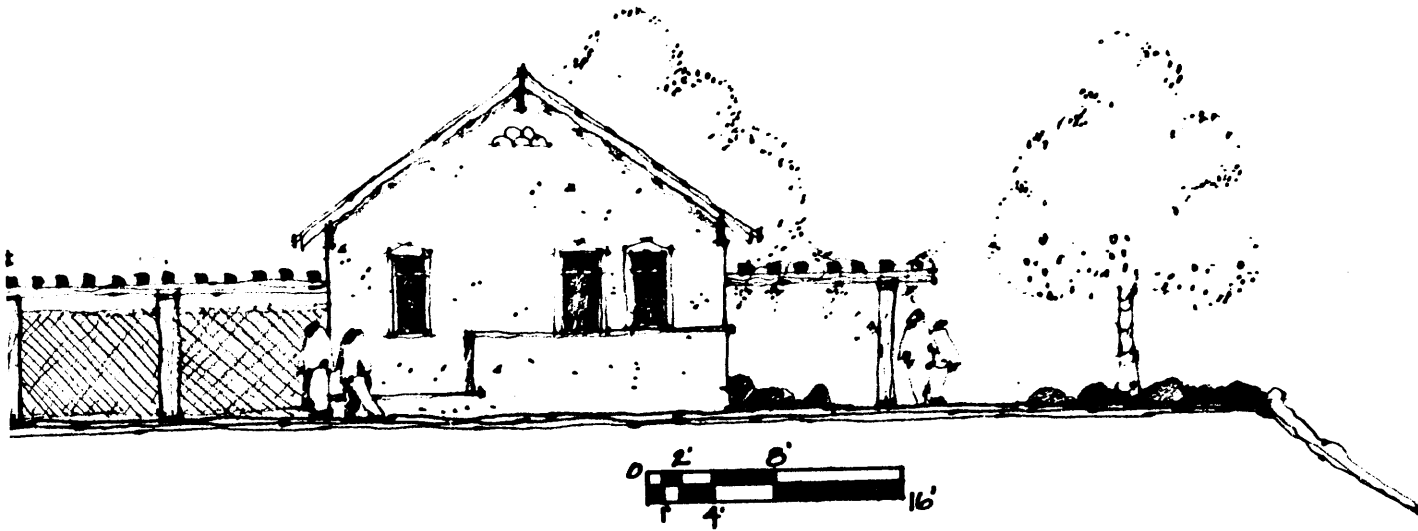
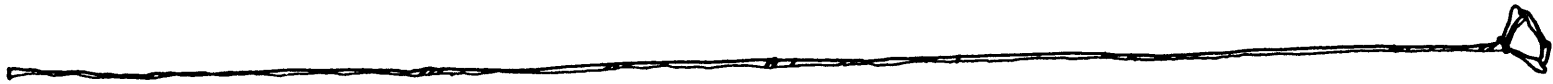

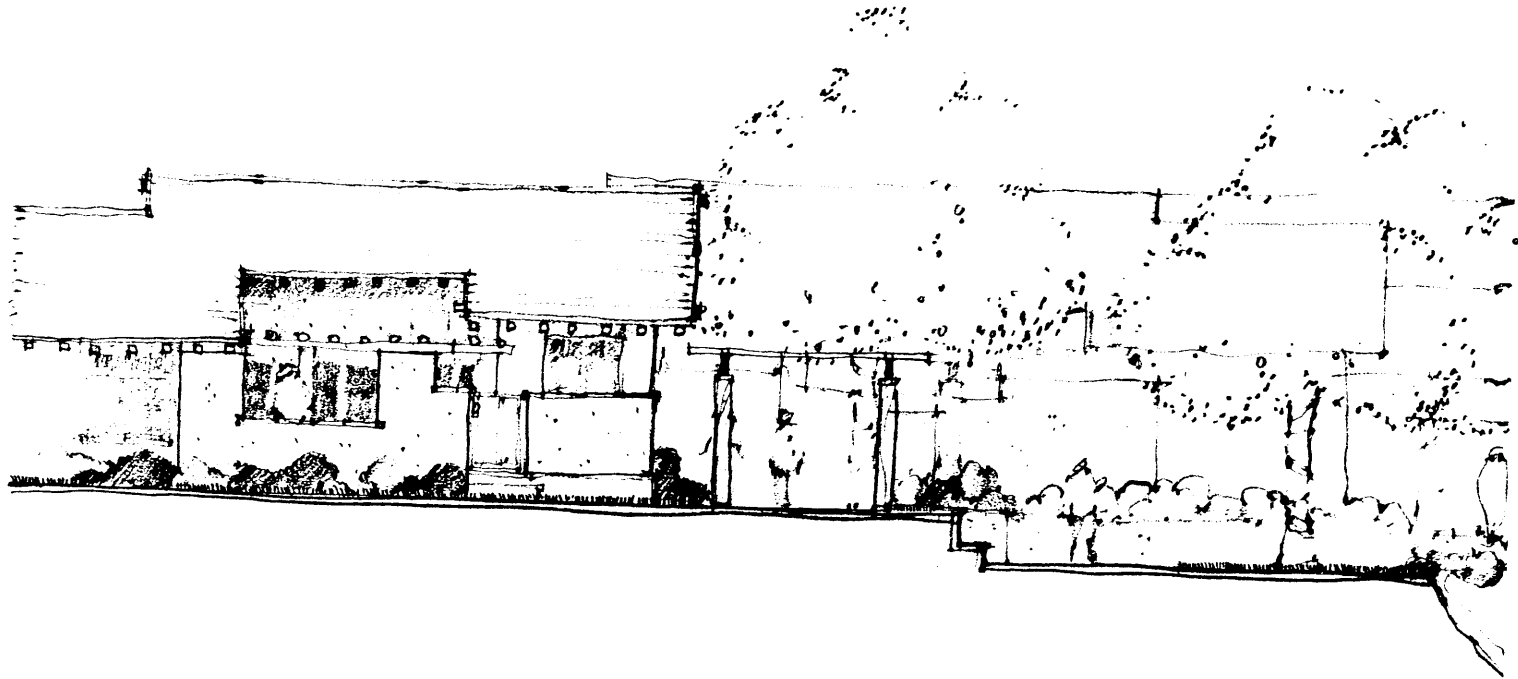
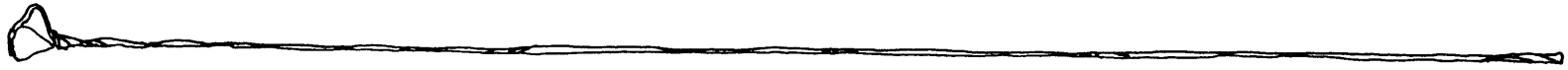

SECTION THROUGH PROMENADE LOC



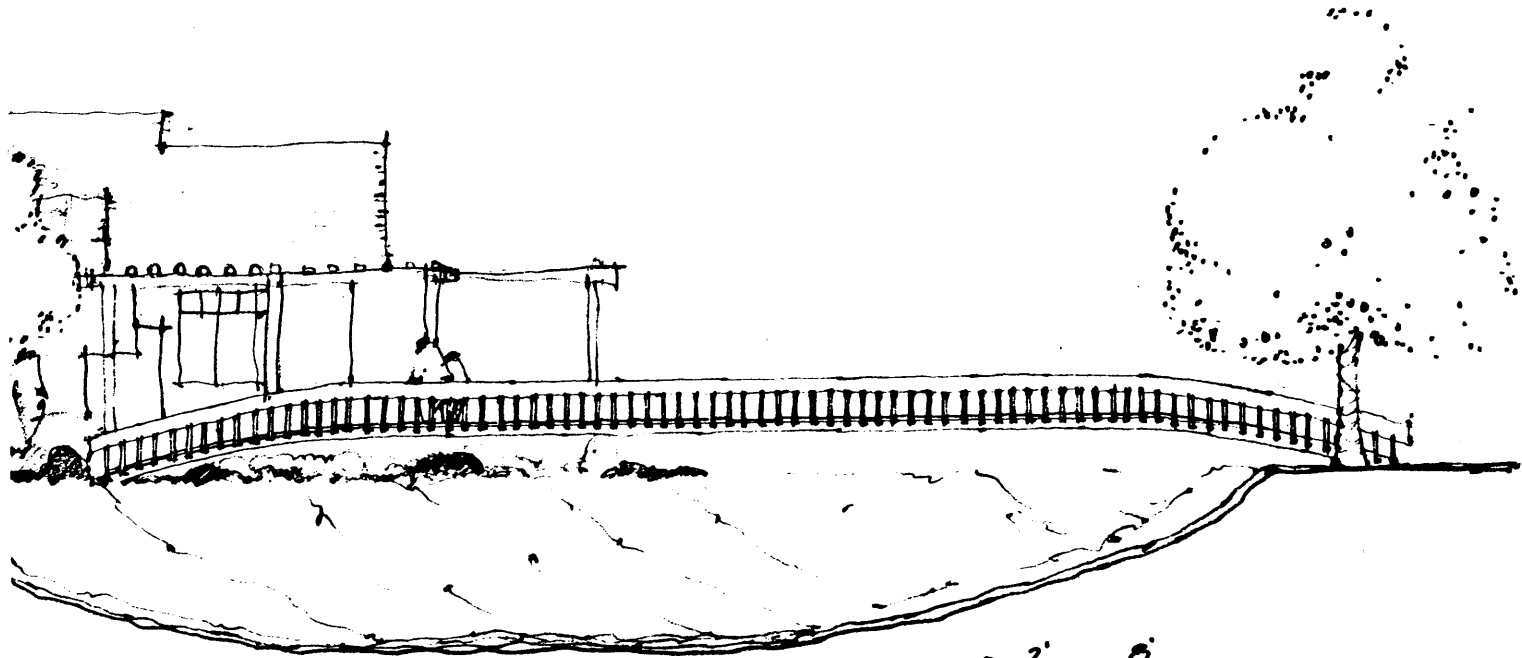

WALKING SOUTH

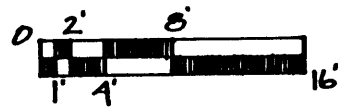

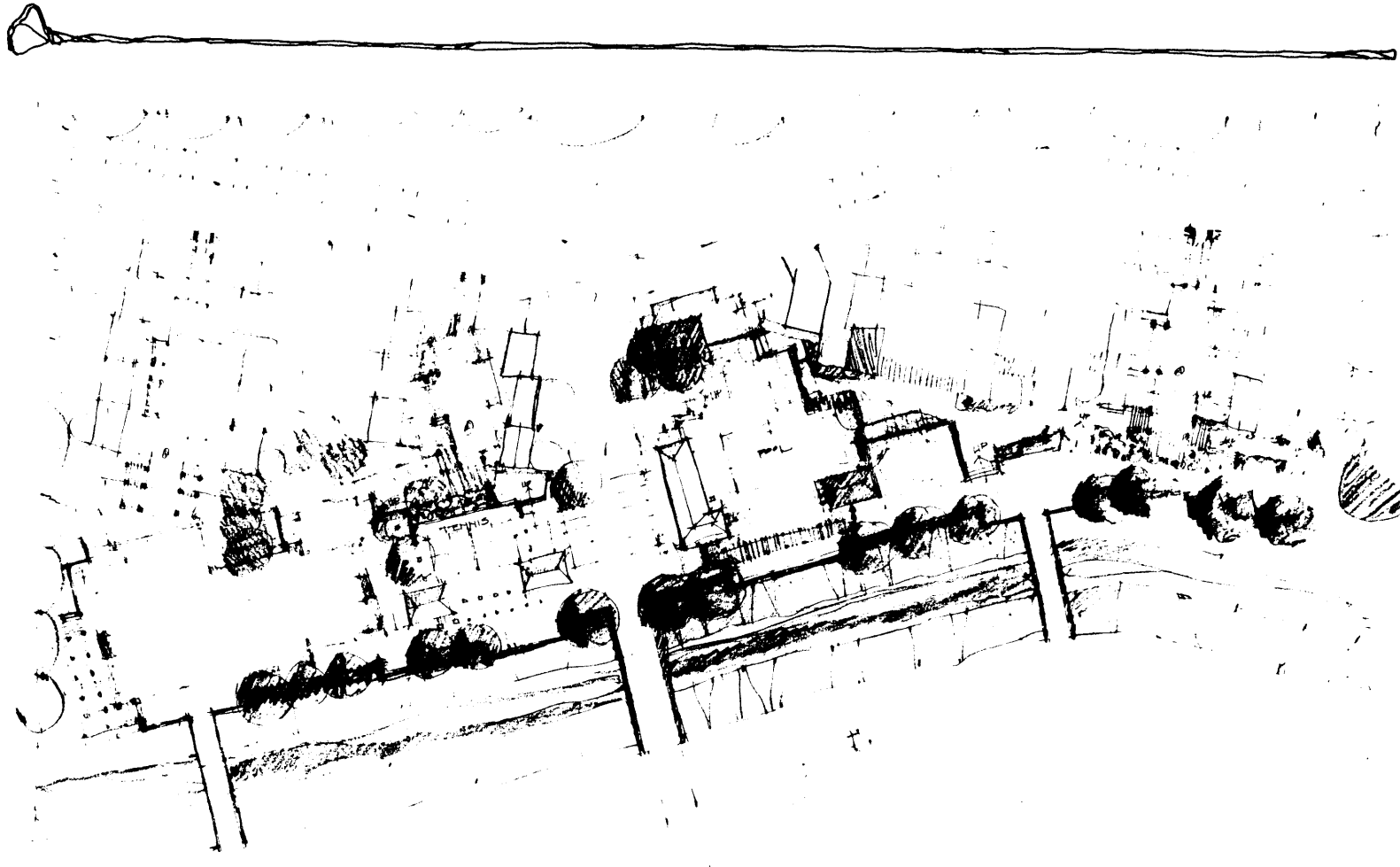

EARLY SITE PLAN STUDY.....

1997-1998



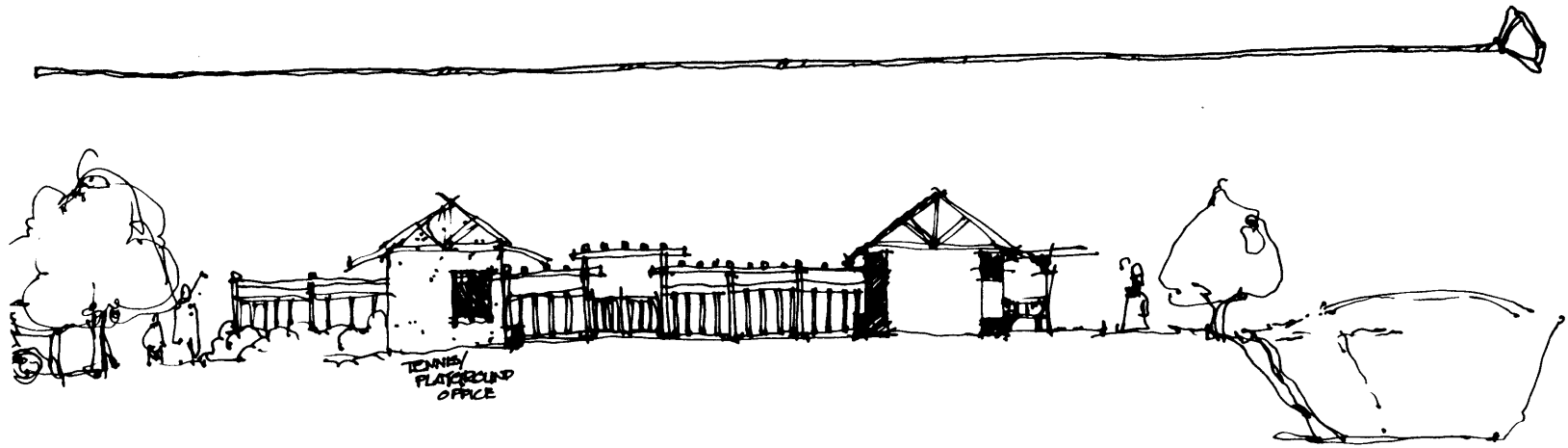

TENNIS  
PLAYGROUND  
OFFICE

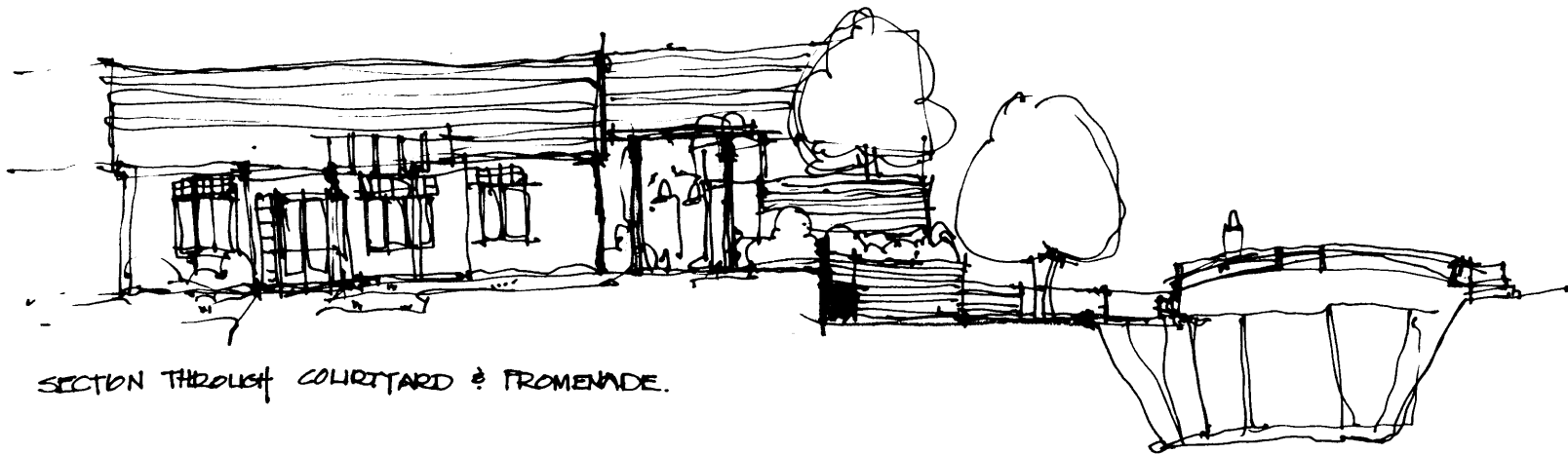

SECTION THROUGH COURTYARD & PROMENADE.

PROMENADE STUDIES.....



## Unit Designs

---

In view of the projects density, the primary objective in unit design was to maximize the development of private outdoor space. Subsequently, the flow between exterior and interior space was to be encouraged through form. In the design of the units themselves, I strove to abide by the many adobe principals laid out previously. However, design innovation was sought in order to bring more light into the common living spaces. Another issue was designing an introverted lay out as a result of common walls.



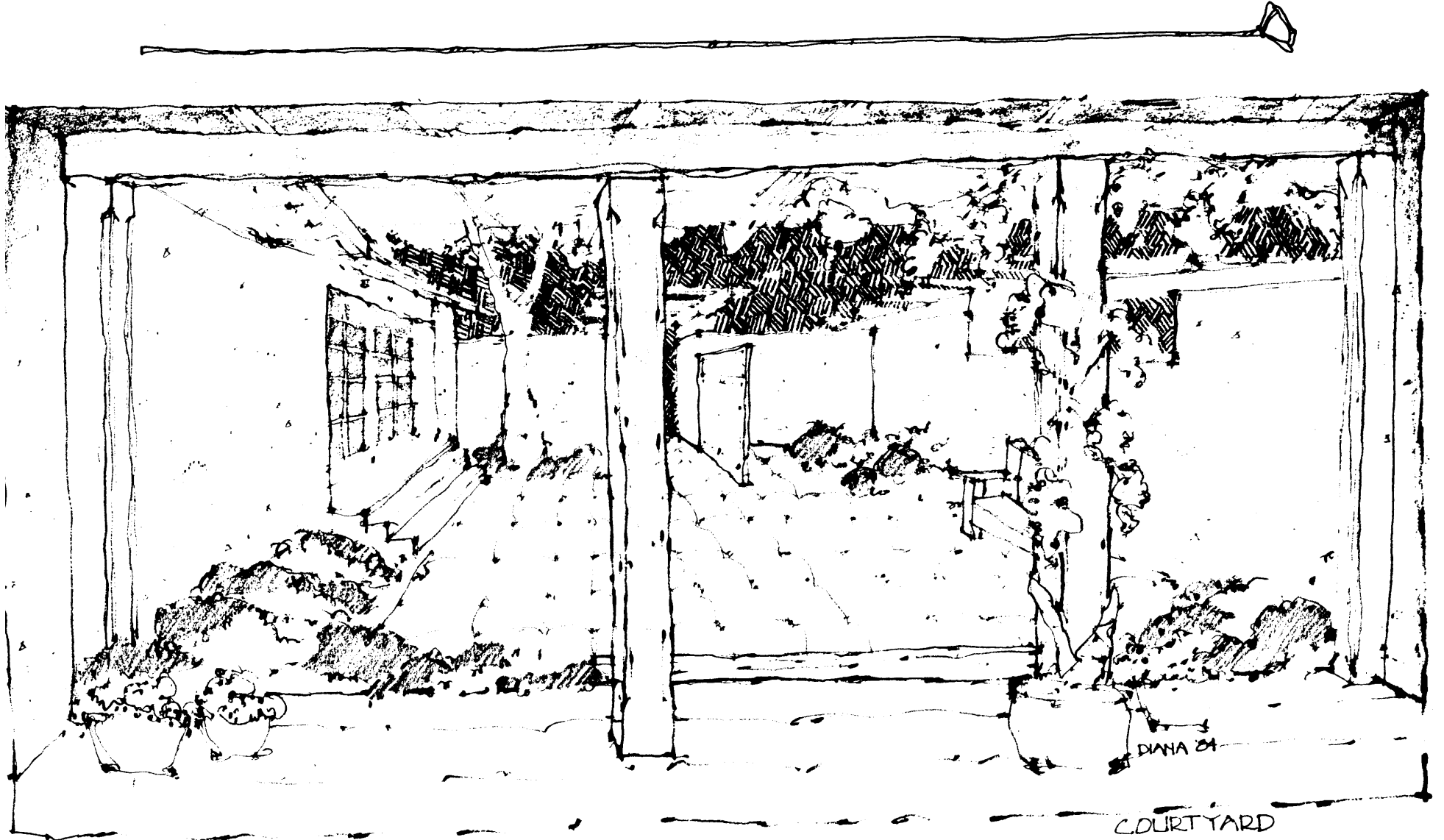

DIANA 04

COURTYARD





# One Bedroom

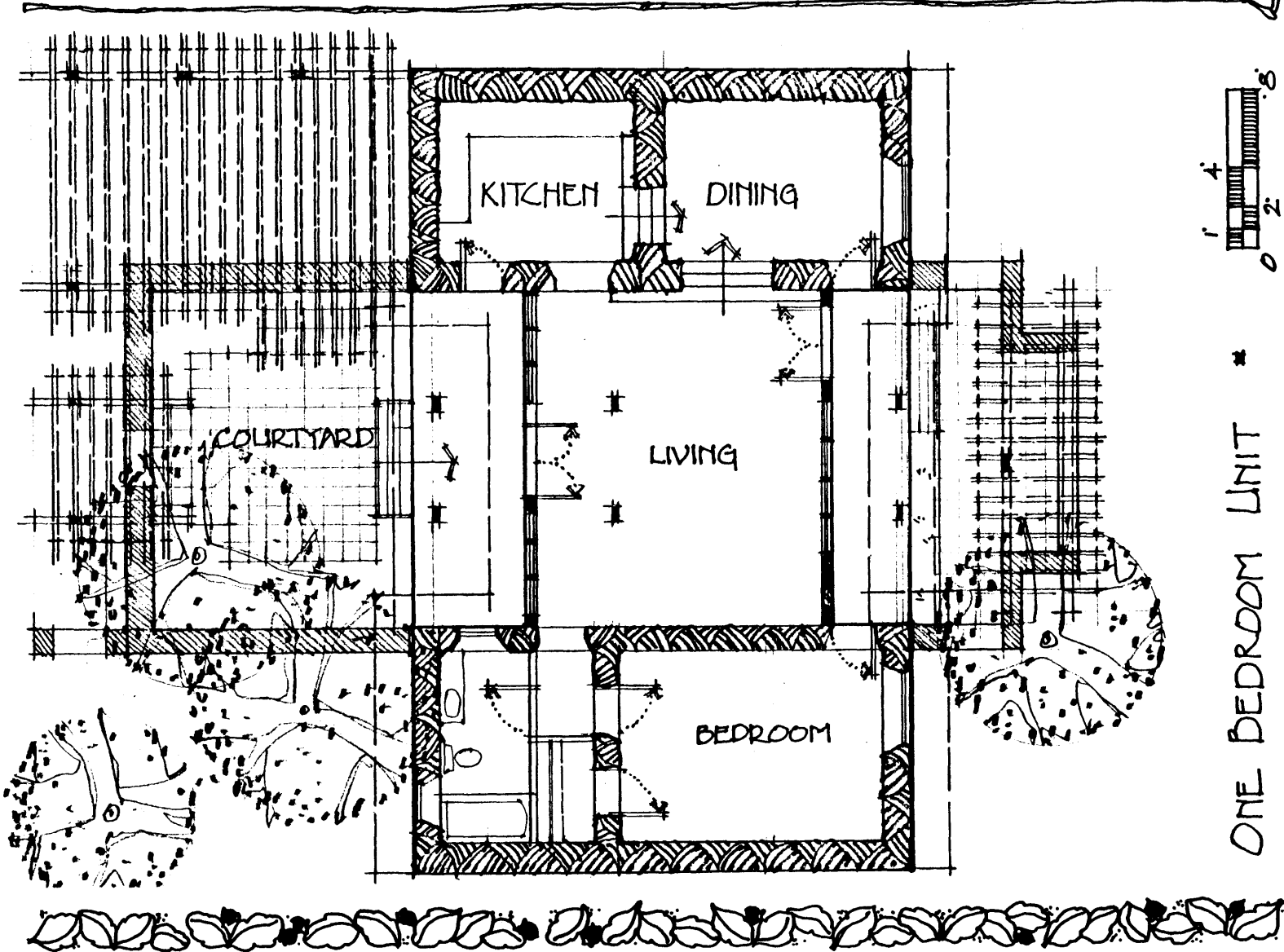

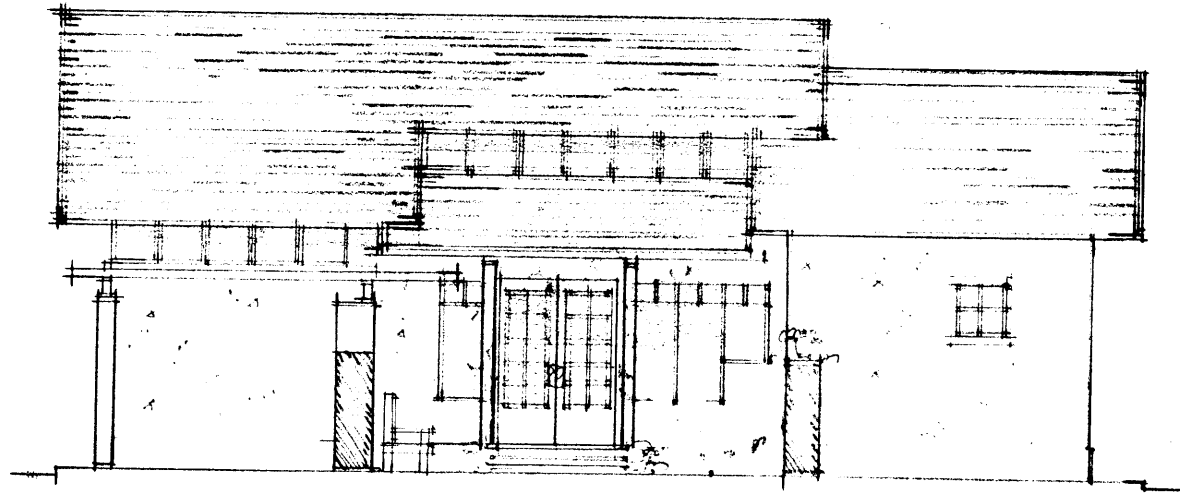
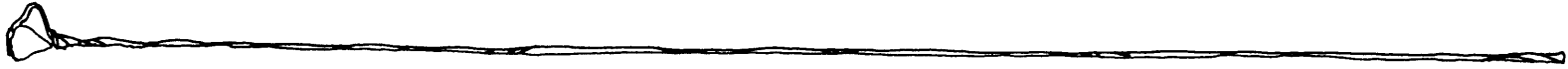

ONE BEDROOM \* STREET ELEV. \*

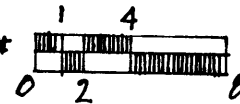

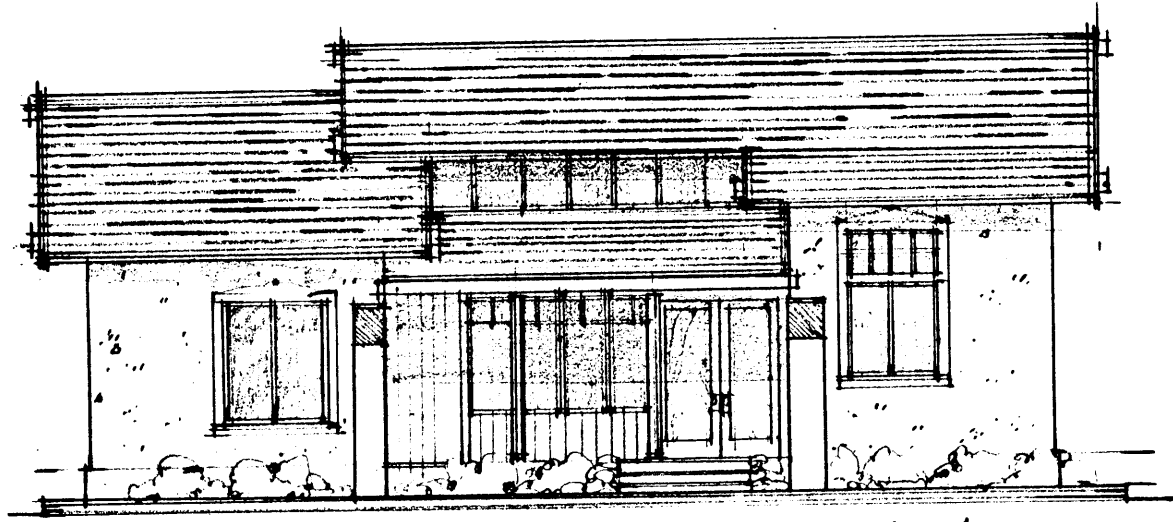
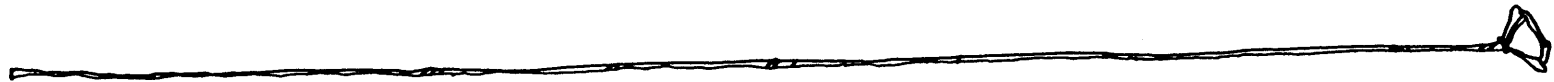

ONE BEDROOM UNIT - CLUSTER ELEV

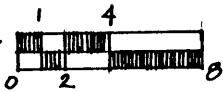



146

STUDY OF LIVING AREA: ONE & TWO BEDROOM UNITS

Two Bedroom

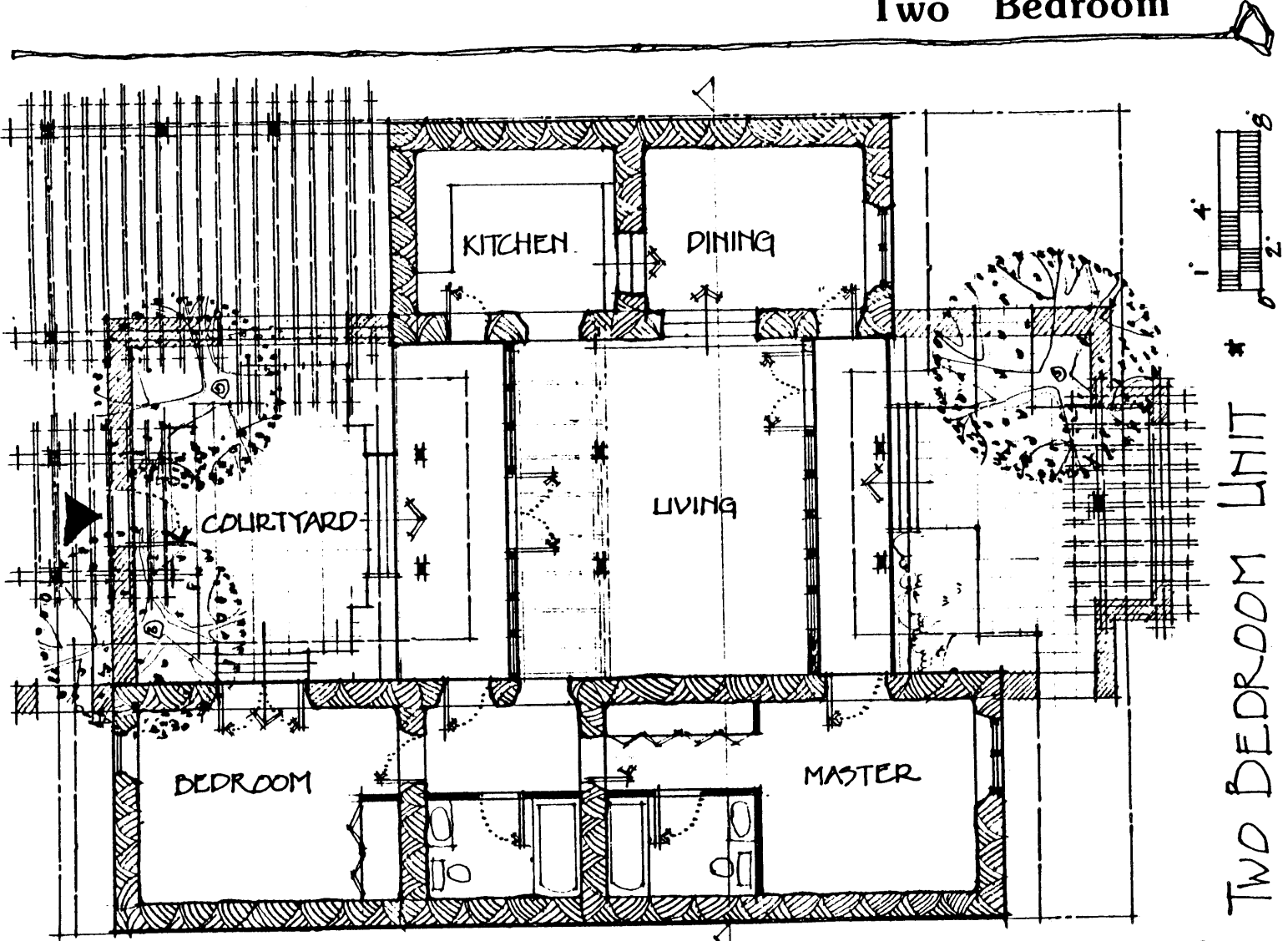

TWO BEDROOM UNIT



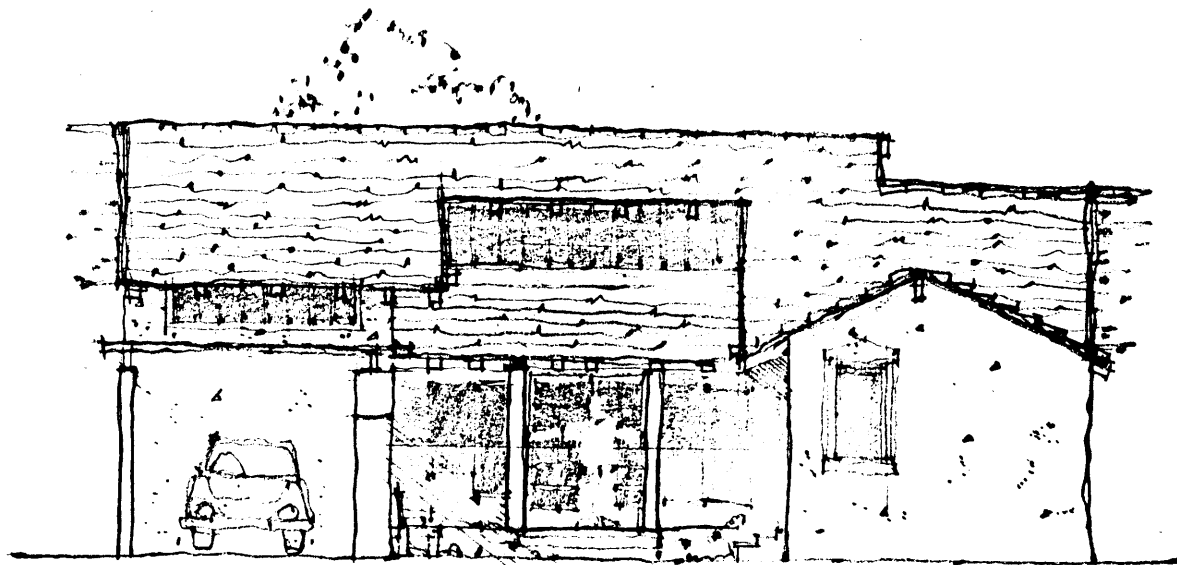

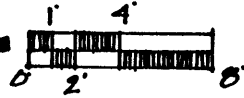
TWO BEDROOM UNIT - STREET ELEV. 



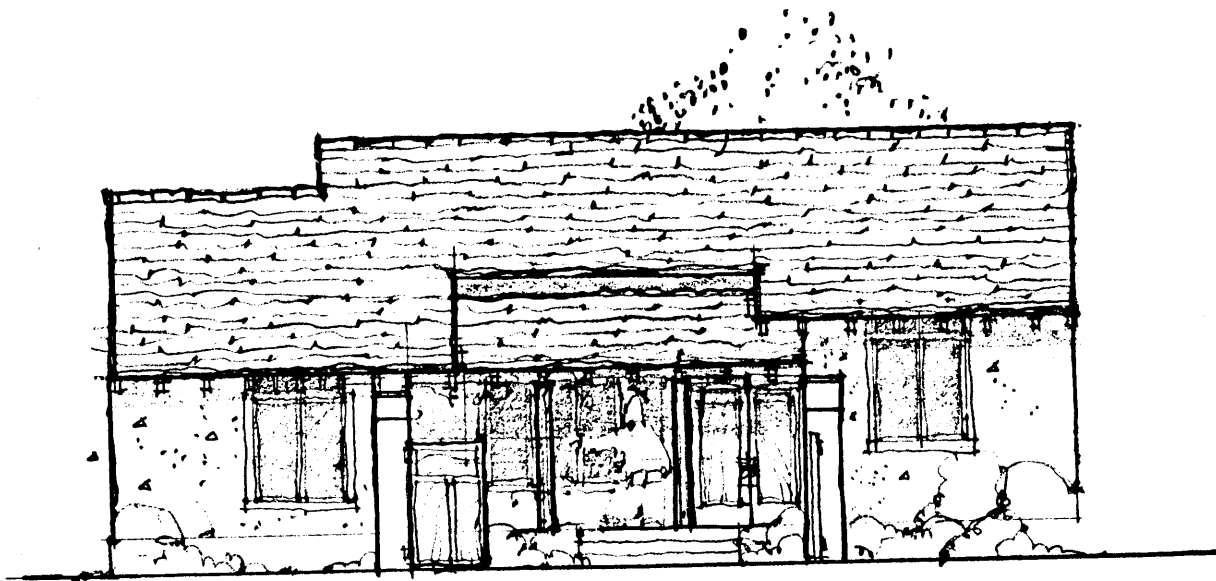
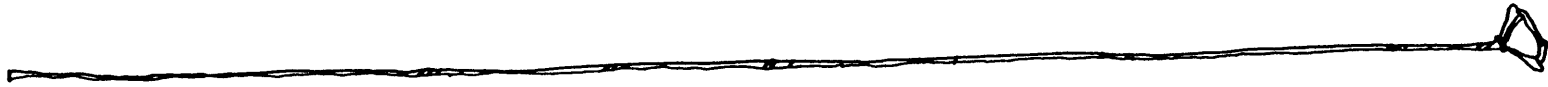

TWO BEDROOM UNIT \* COMMON ELEV. \* 



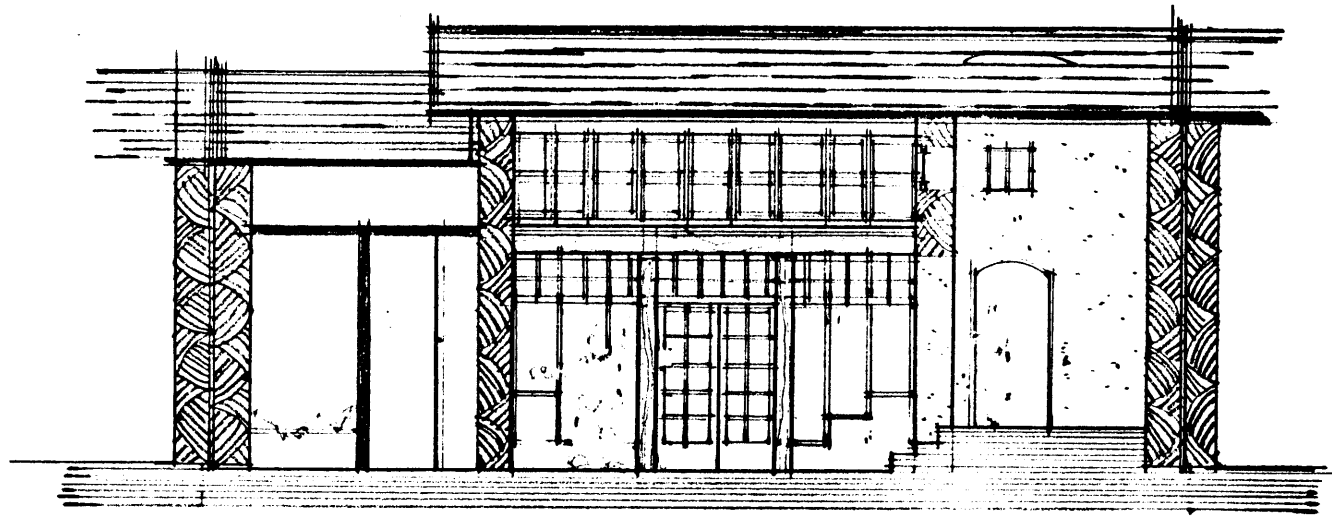
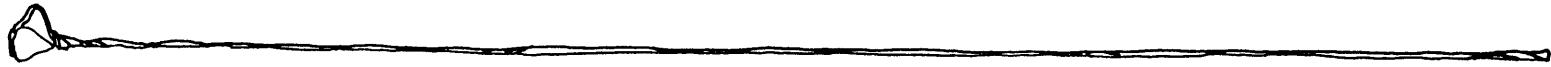

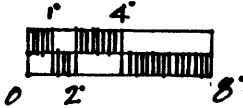
TWO BEDROOM UNIT \* LONG SECTION \* 



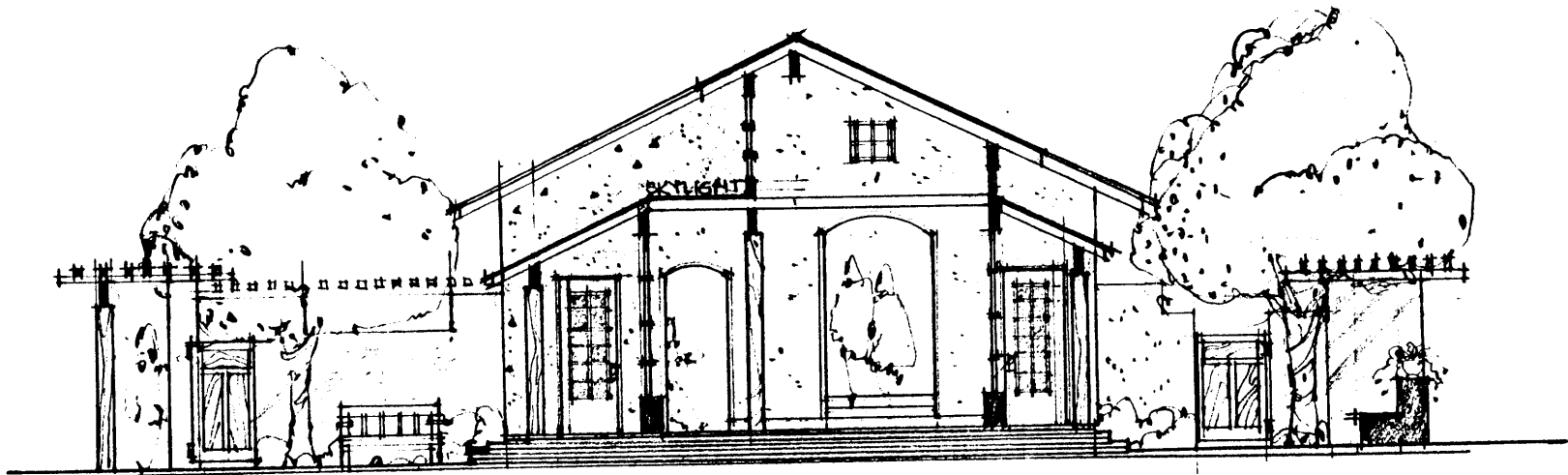
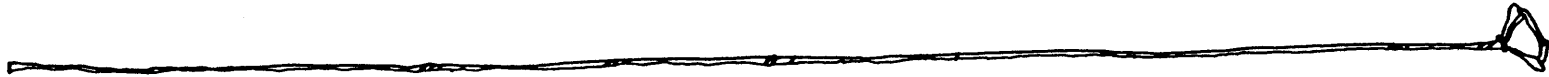

2 BEDROOM UNIT \* CROSS SECTION \*

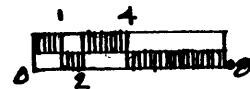

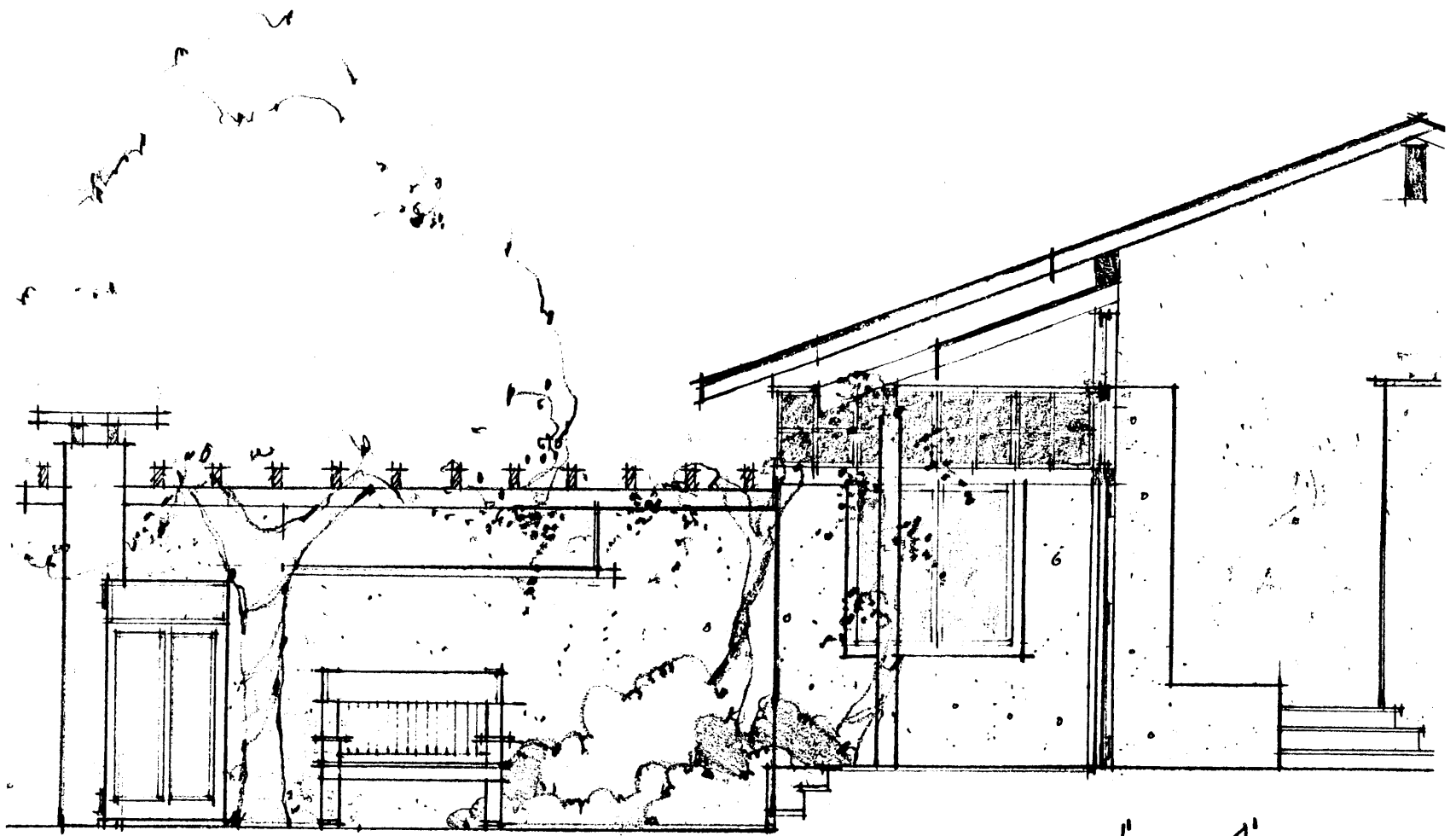

152

STUDY OF COURTYARD

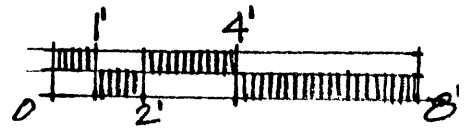

# Three Bedroom

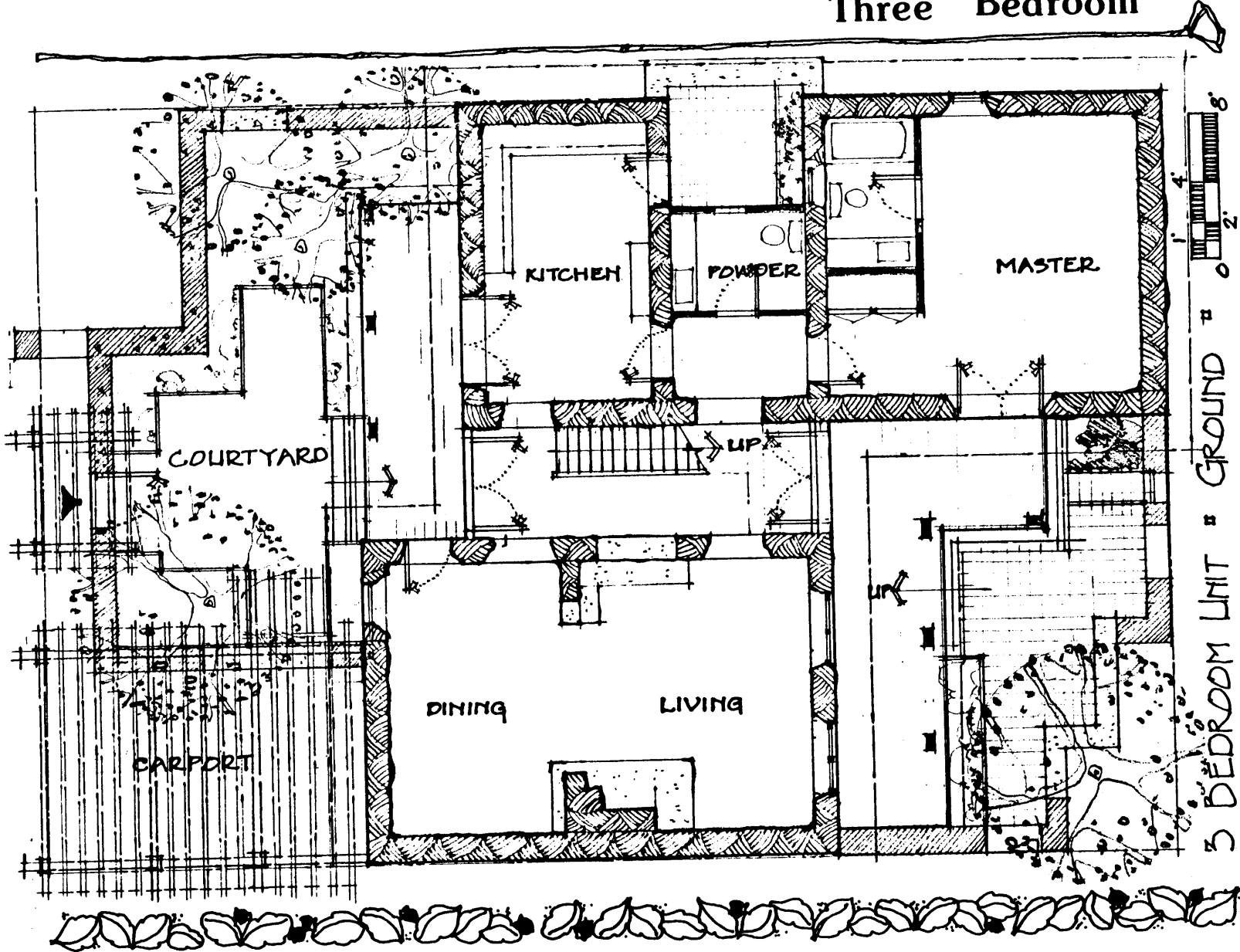

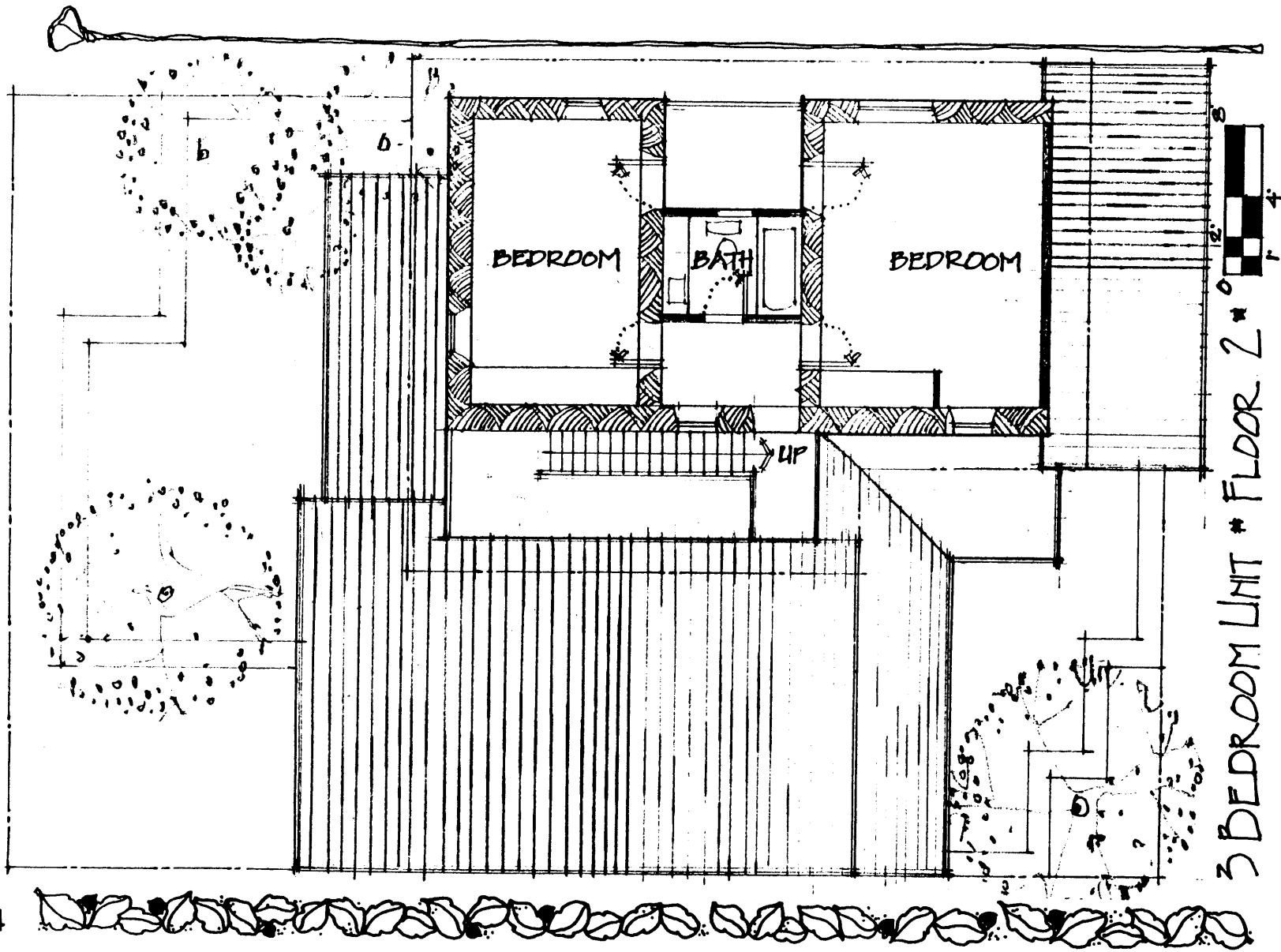

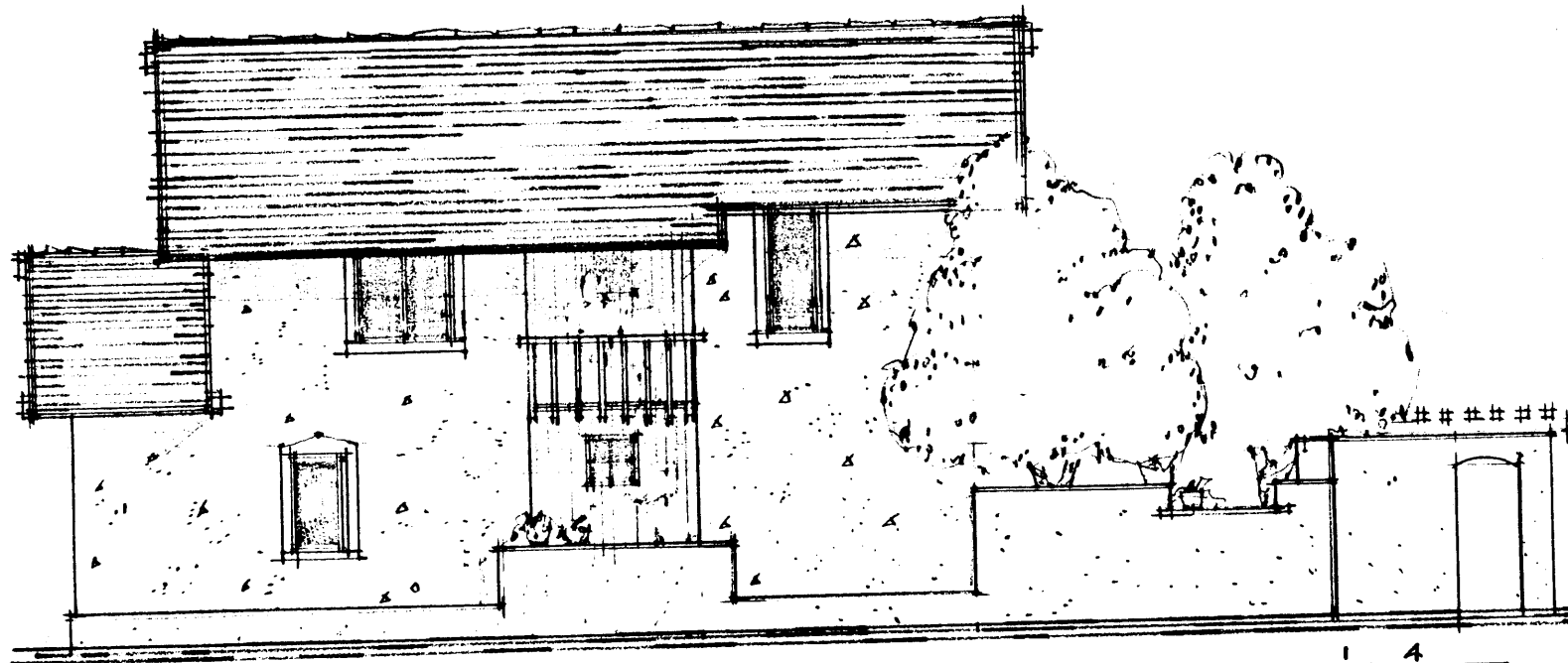

3 BEDROOM UNIT - MAJOR STREET ELEVATION

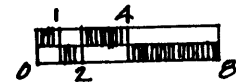

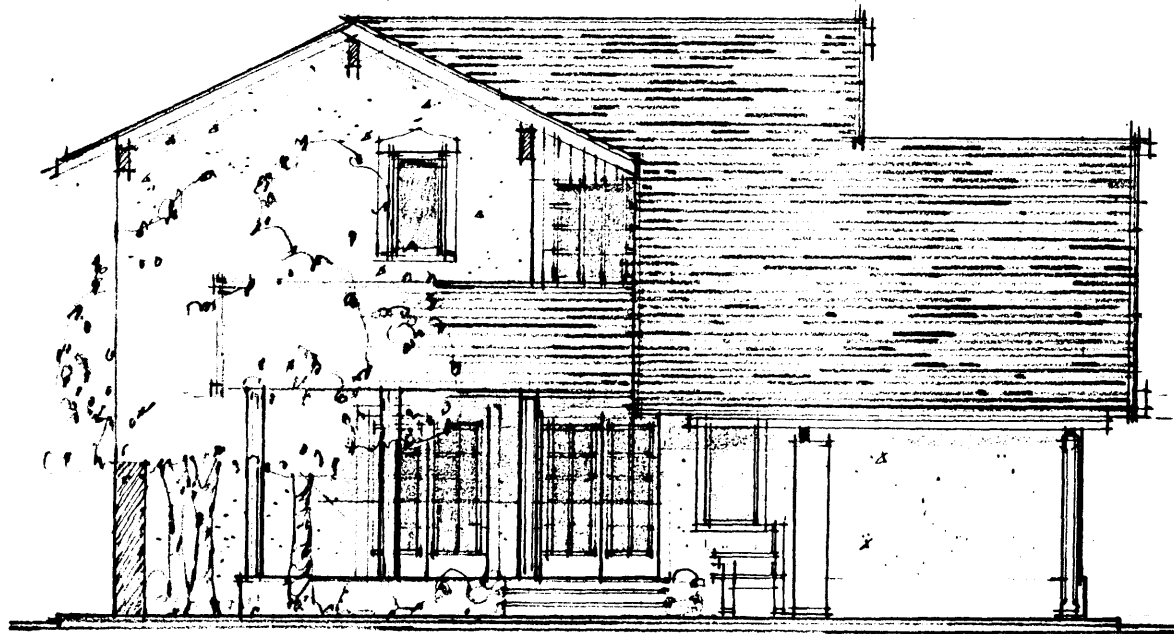
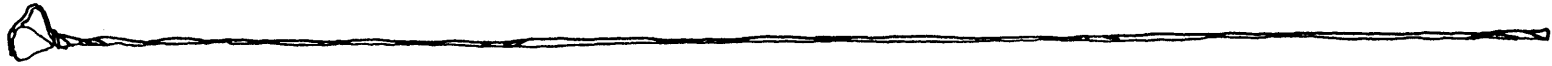

3 BEDROOM UNIT \* BACK ELEV \*

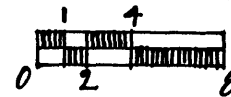

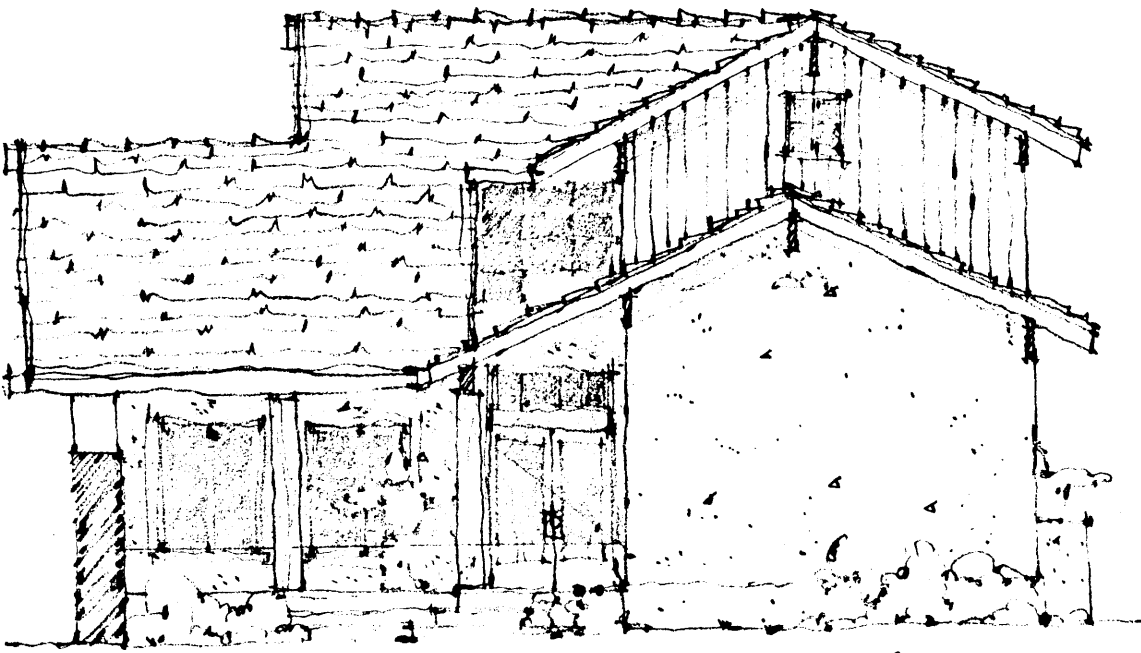
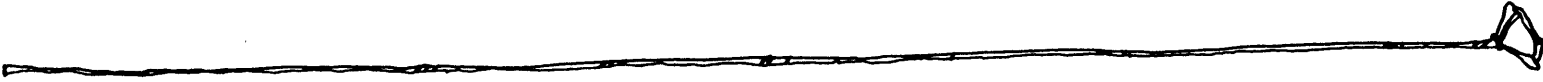

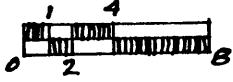
3 BEDROOM UNIT - CLUSTER ELEV. # 



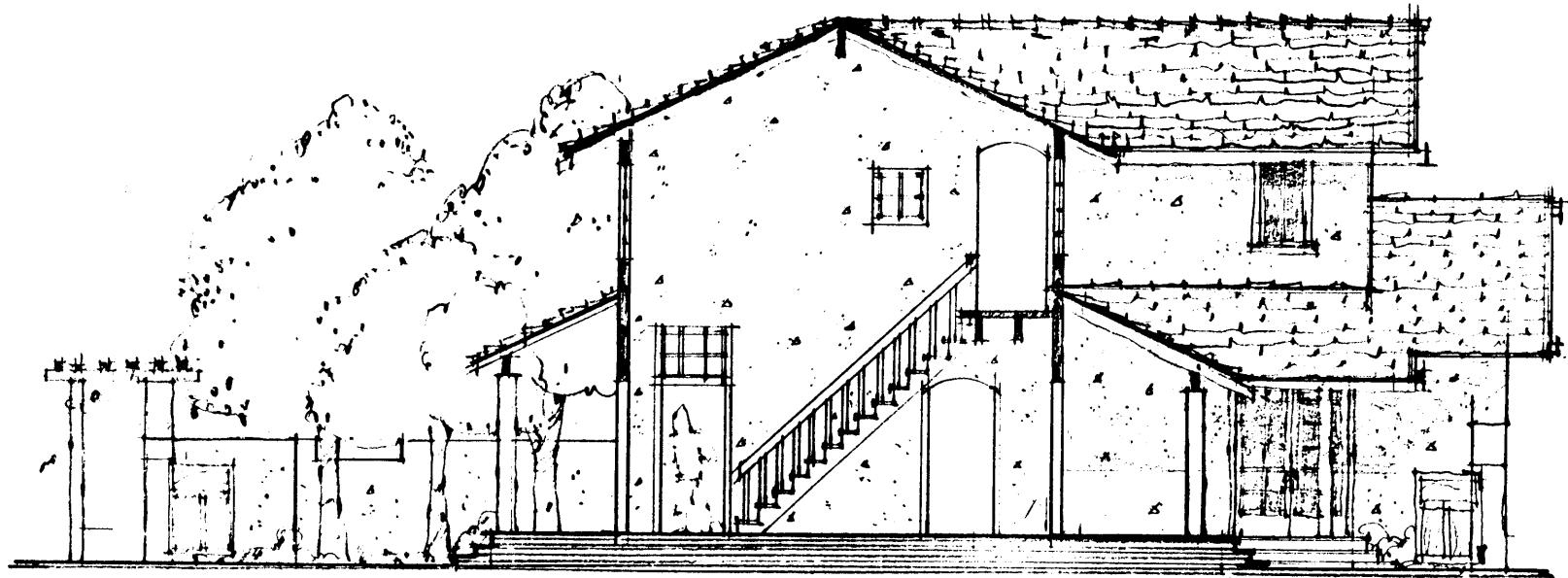

THREE BEDROOM UNIT ■ CROSS SECTION ■

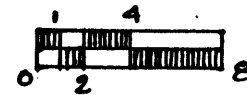

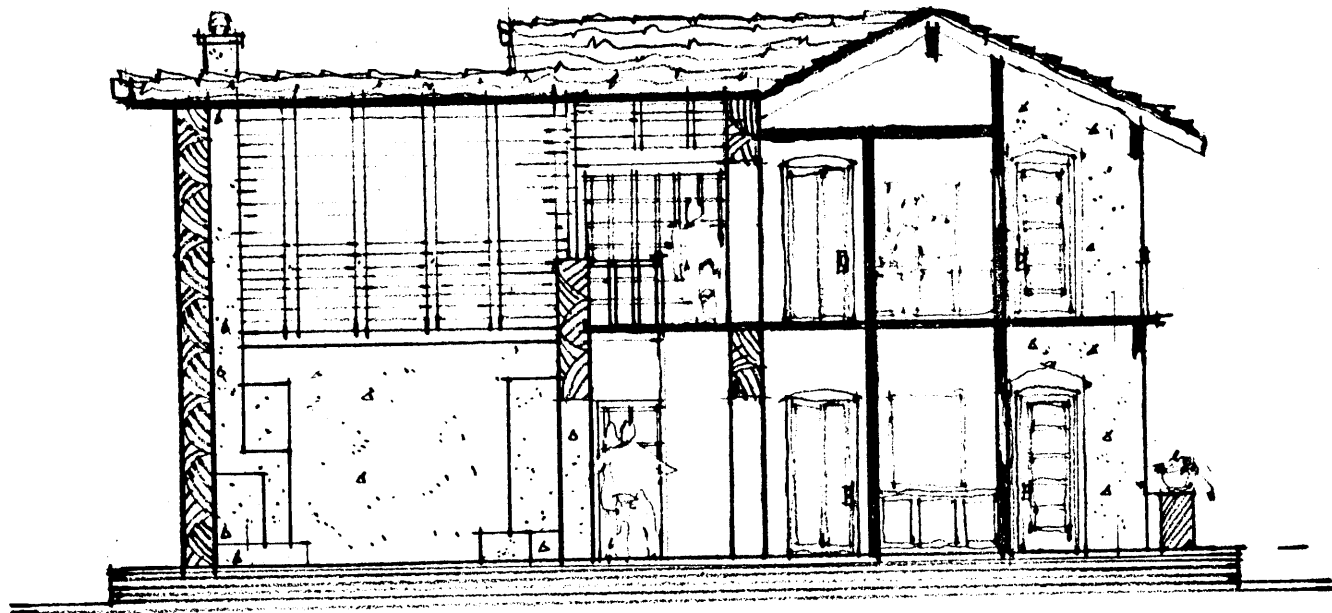
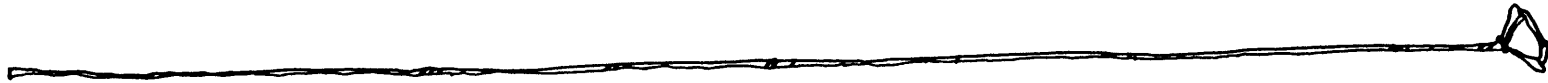

3 BEDROOM UNIT - LONG SECTION

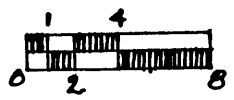

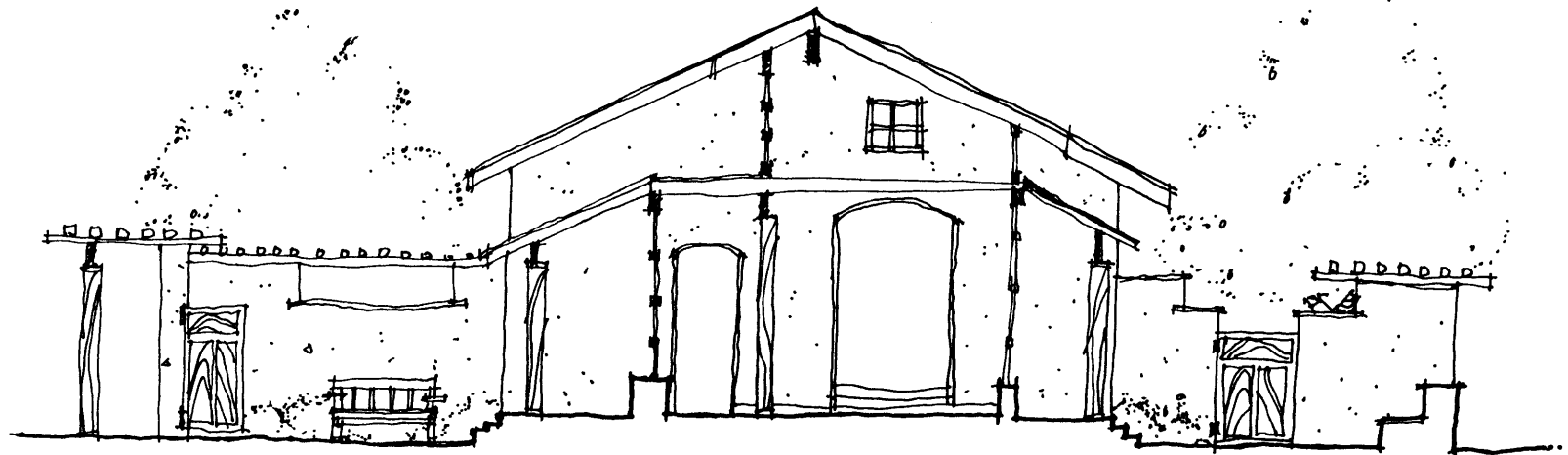
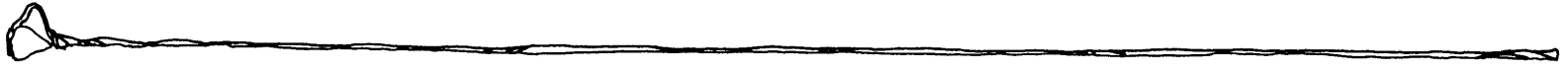

UNIT PRIVACY HIERARCHY



## Unit Clusters



The individual units are much smaller than the structures analyzed in the framework. Additionally, it was desired that they be attached to one another in order to diminish costs. These constraints required that the historic forms studied be used as an analogy for the layout of units and consequently, the housing clusters. In this analogy, the historic layout is that of a courtyard house. However, in this project, each unit is located in the cluster as a room would be located in a single traditional building.

Like a courtyard house, the "U" form of the cluster opens on to and embraces the landscape. And here too landscape elements mark the transition zone between the built form's interior space and the landscape.

However, the analogy breaks down in regard to exterior circulation space. Traditionally, the courtyard is ringed by a corridor providing outdoor circulation. However single units require privacy at their building edge, and it is more appropriate for circulation to take place within the courtyard.



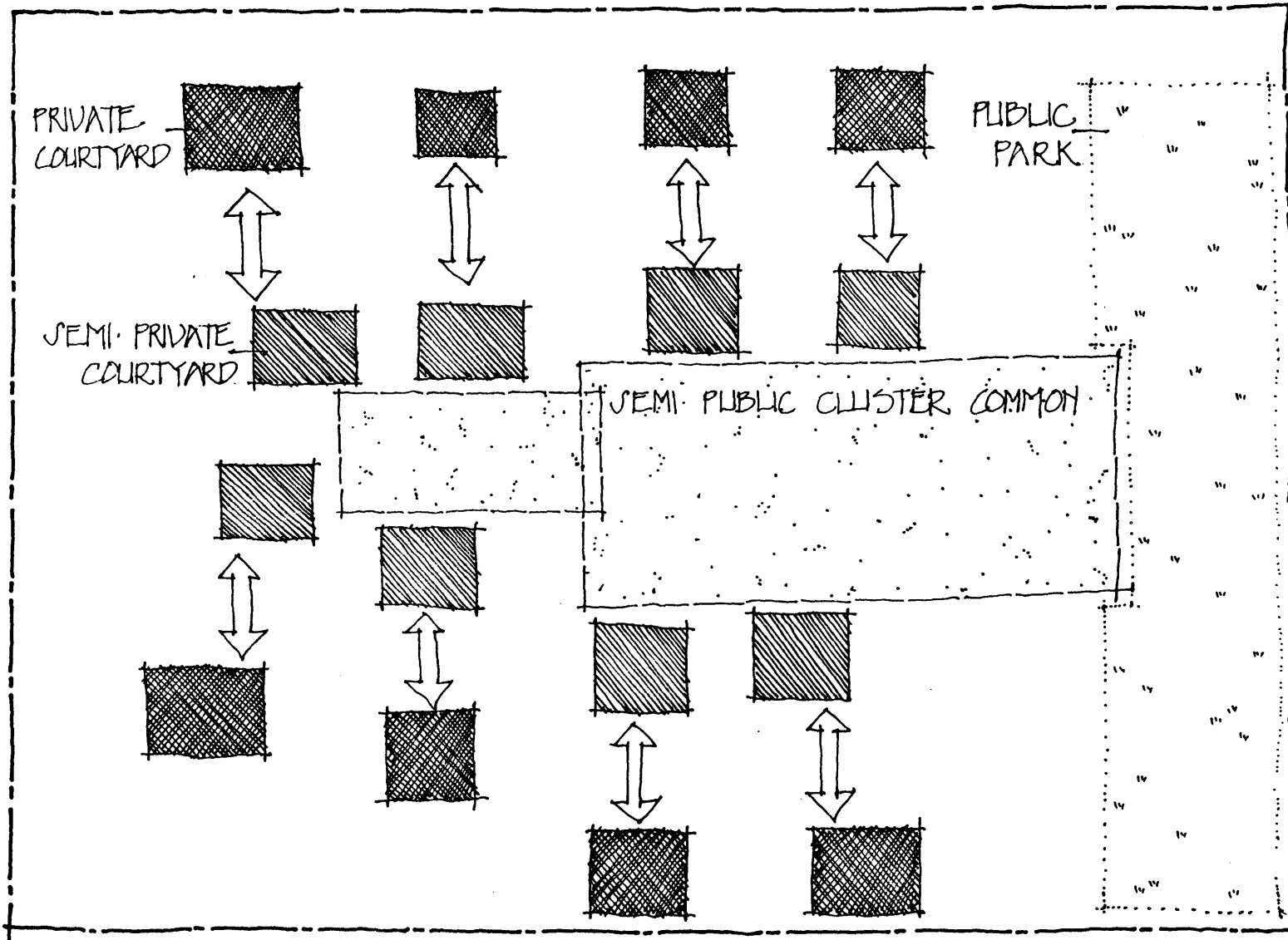

CLUSTER PLAN: HIERARCHY OF OUTDOOR SPACE



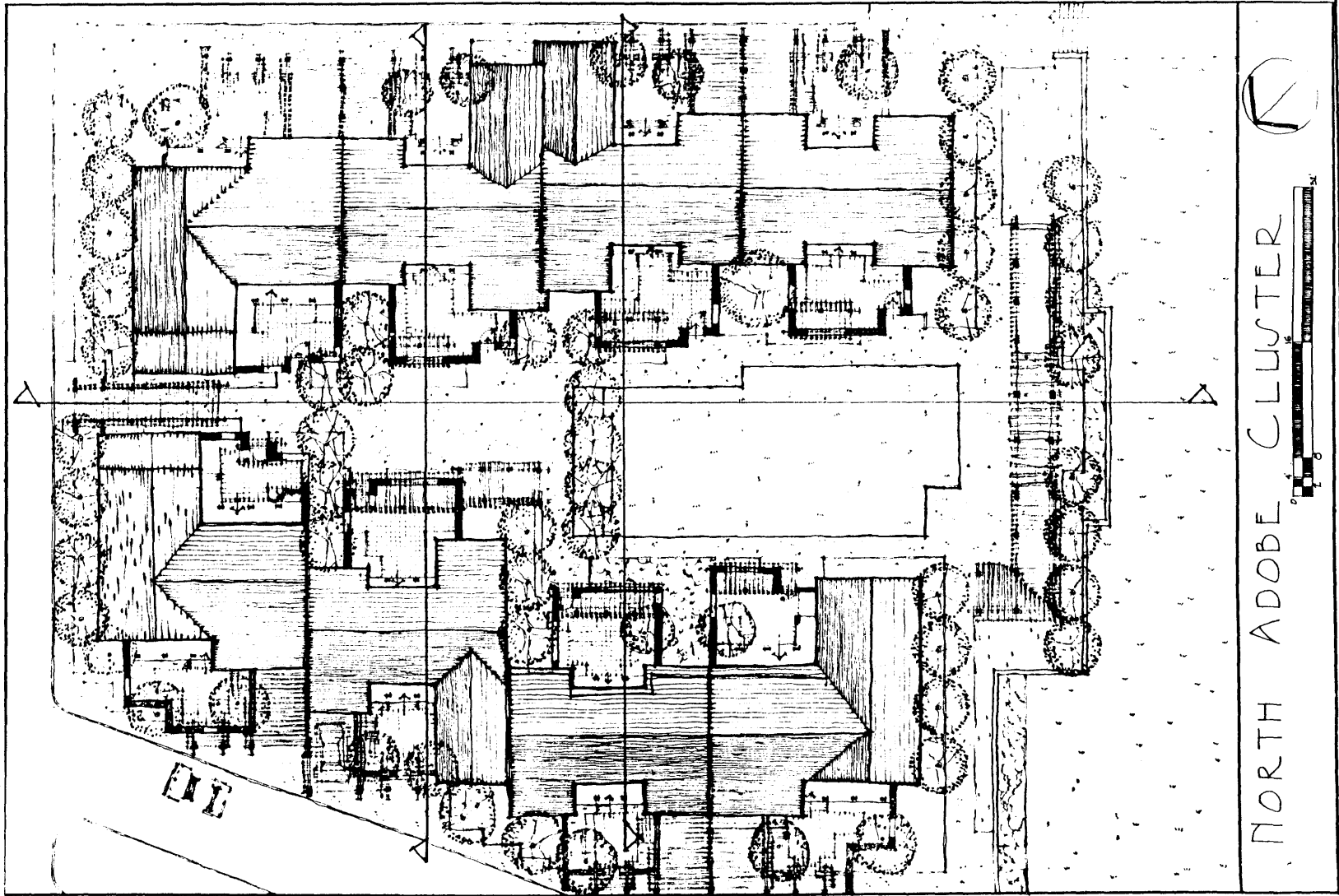

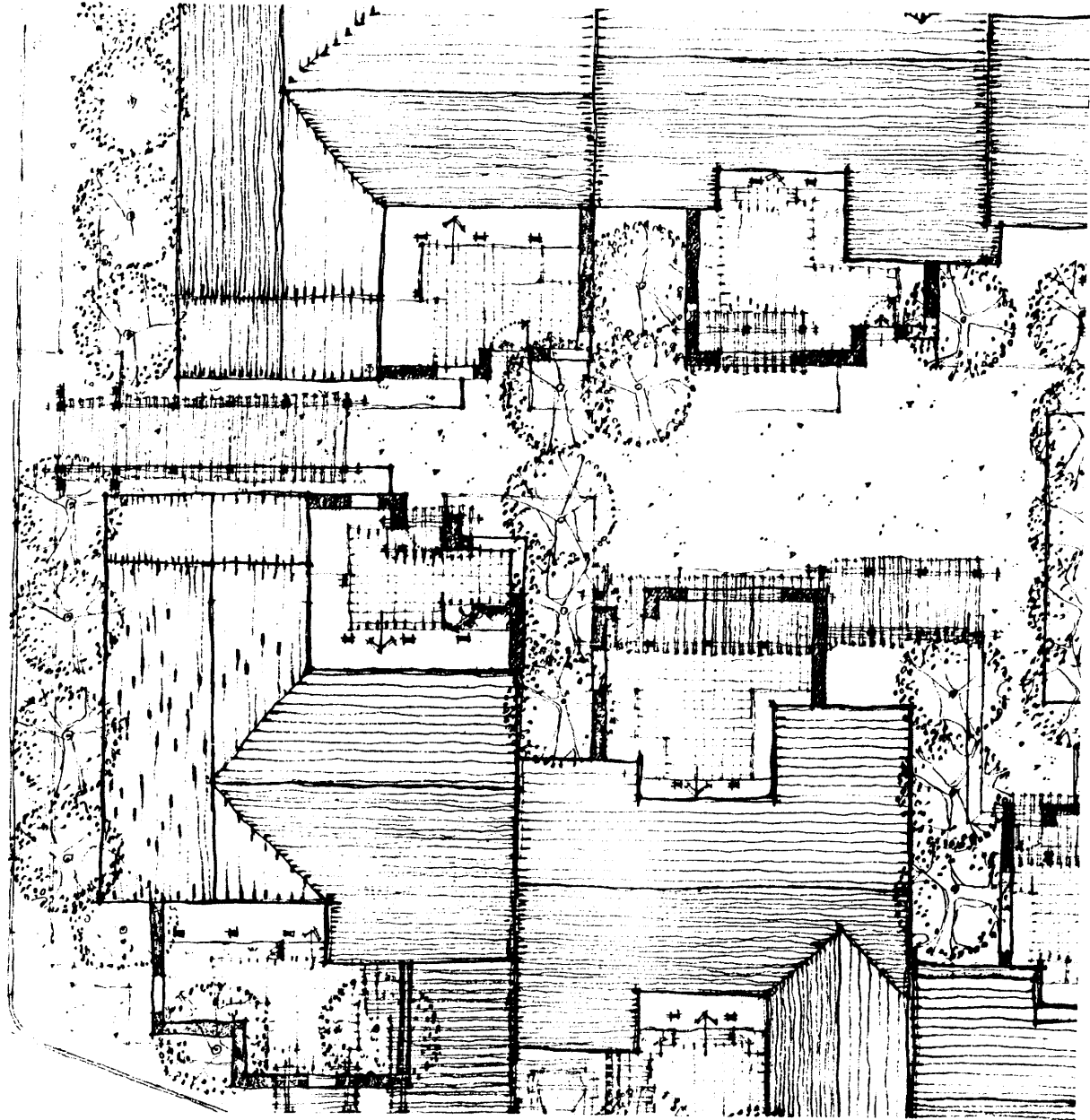
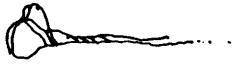

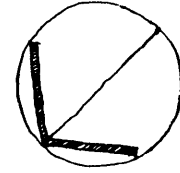
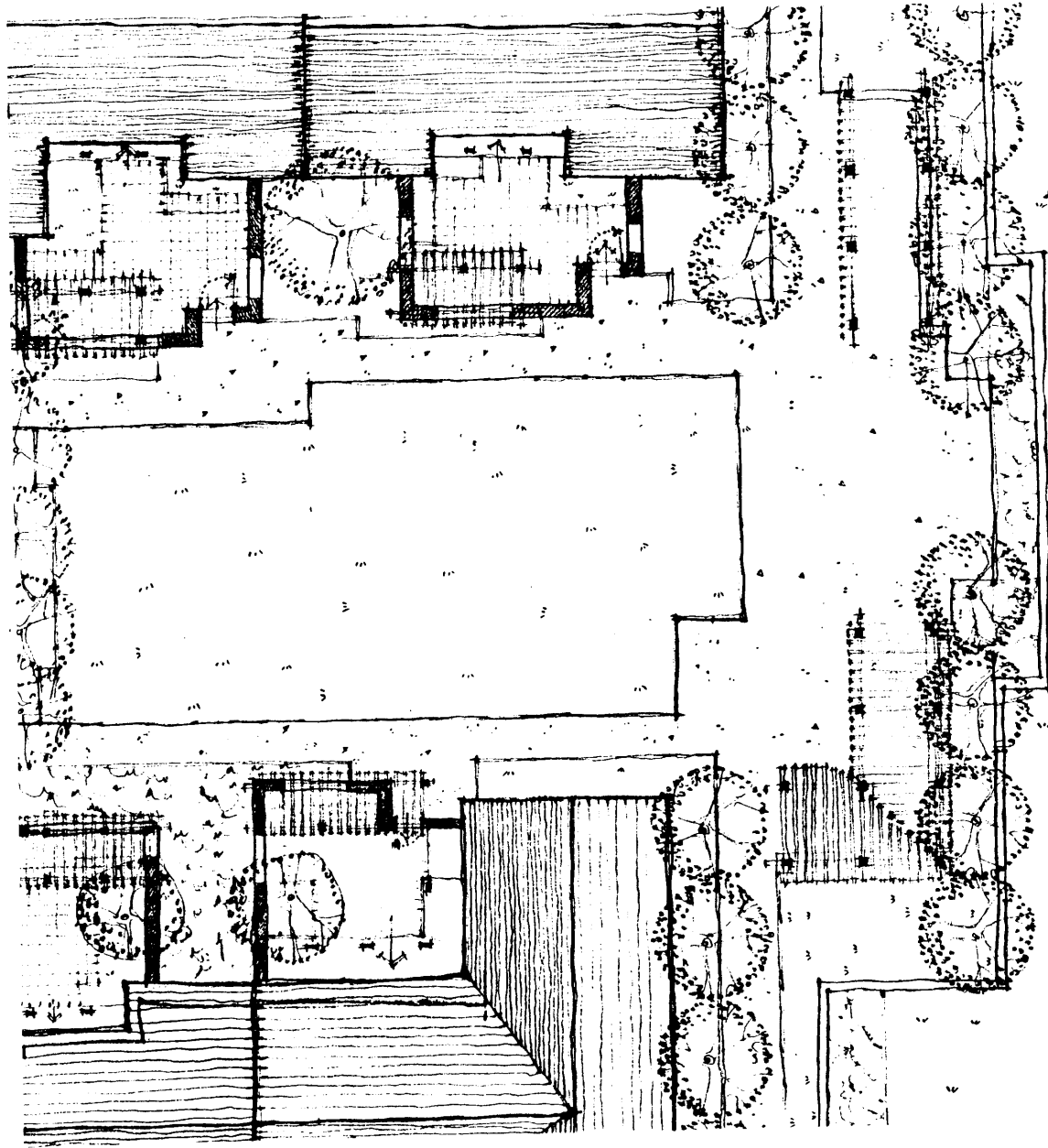

ADOBE CLUSTER

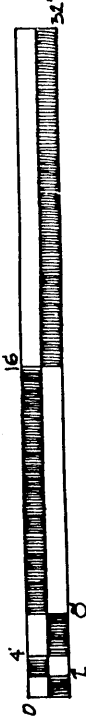

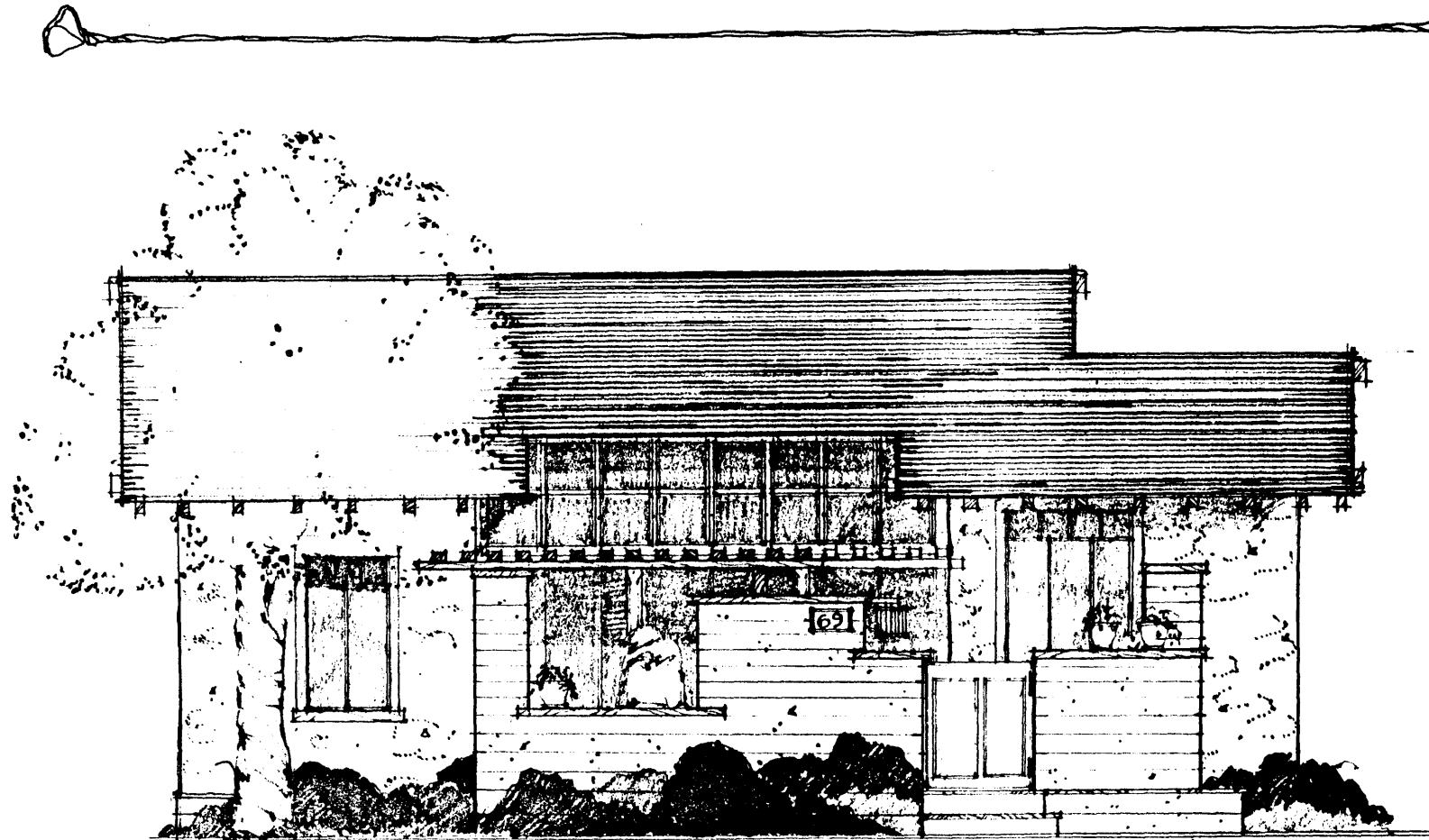

CLUSTER ELEVATION STUDY

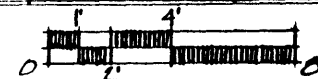

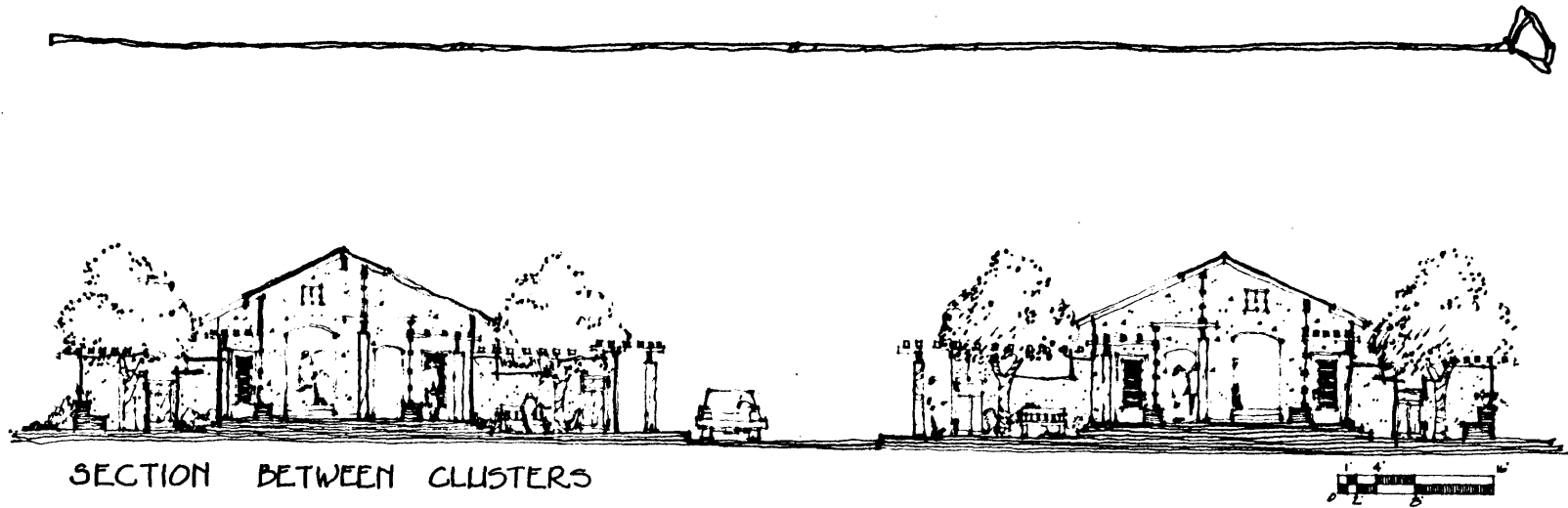

SECTION BETWEEN CLUSTERS

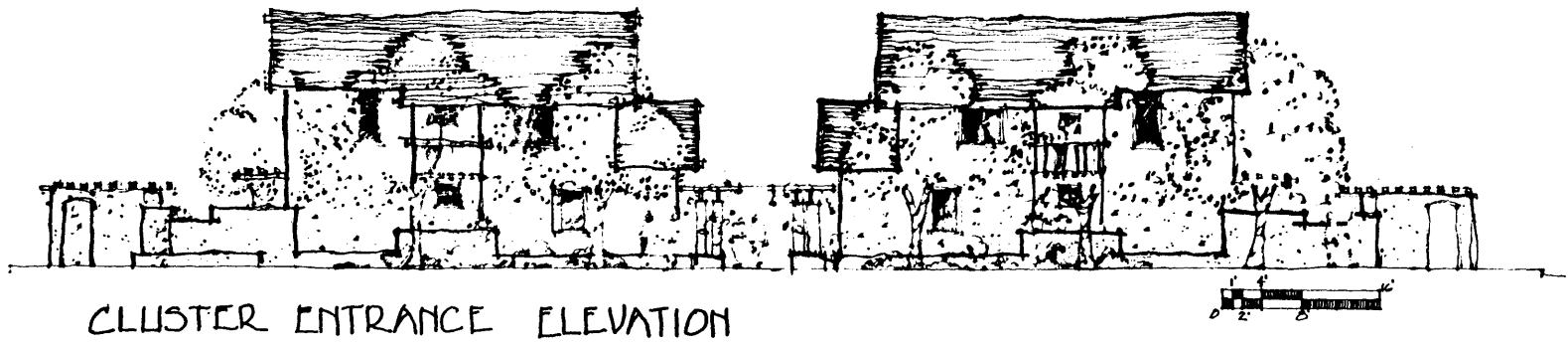

CLUSTER ENTRANCE ELEVATION



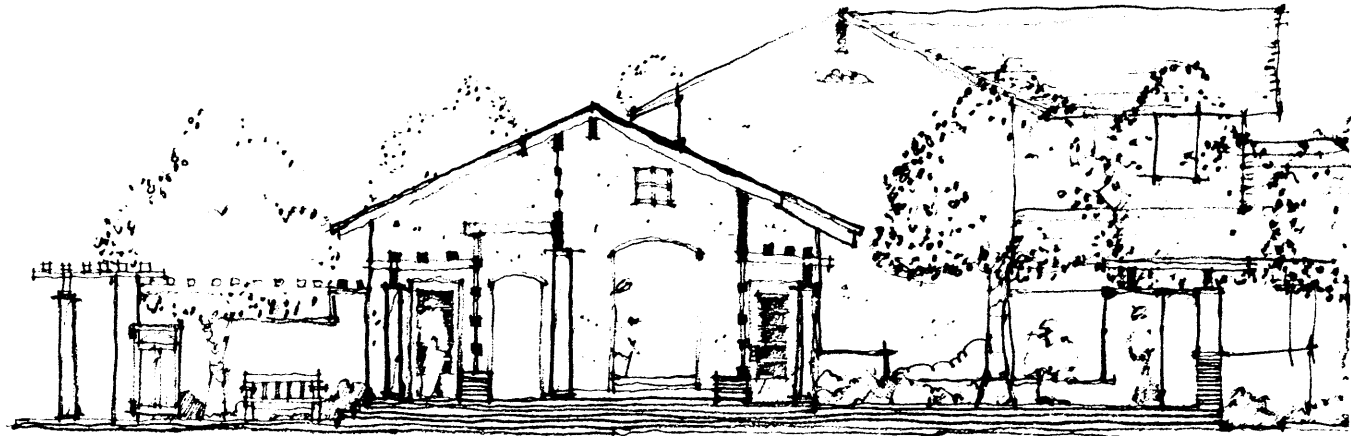

CROSS SECTION LOOKING TOWARDS STREET OPENING



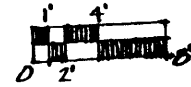
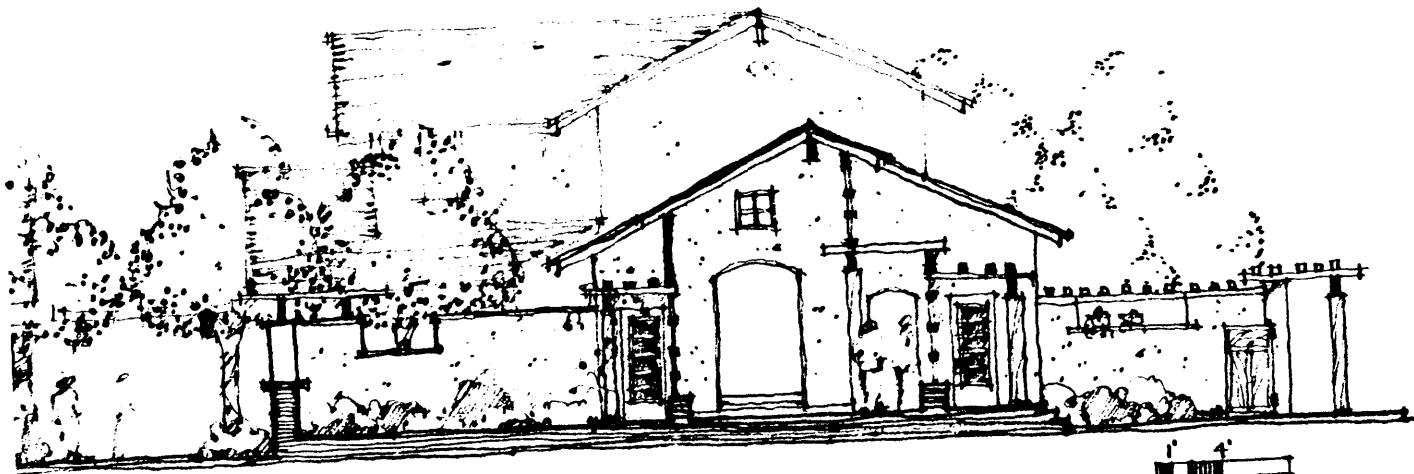

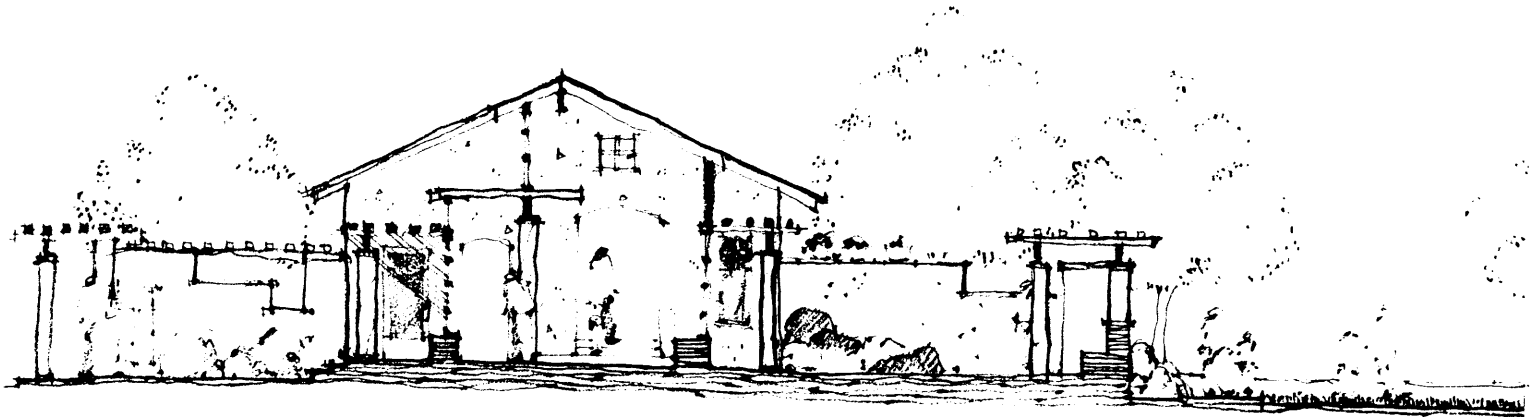
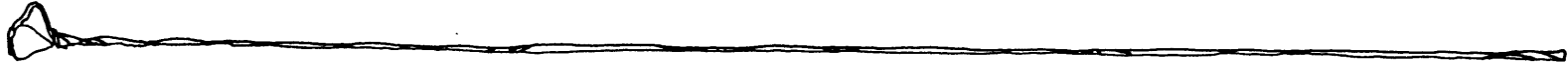

CROSS SECTION LOOKING TOWARDS PARK



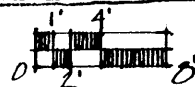
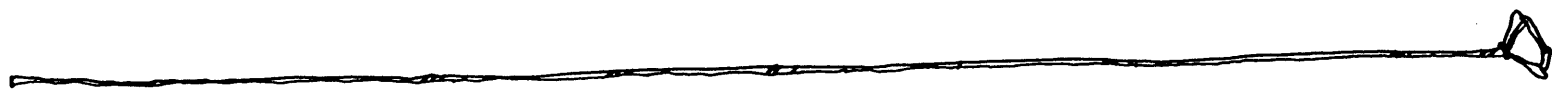

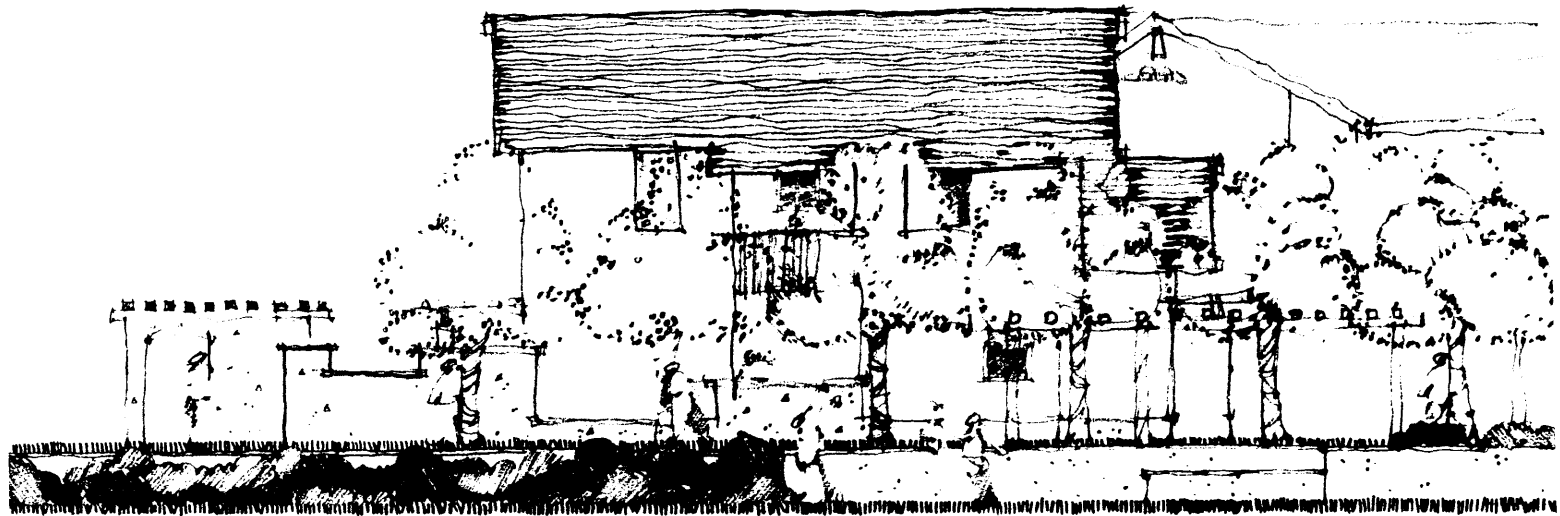

CLUSTER ELEVATION FROM PARK



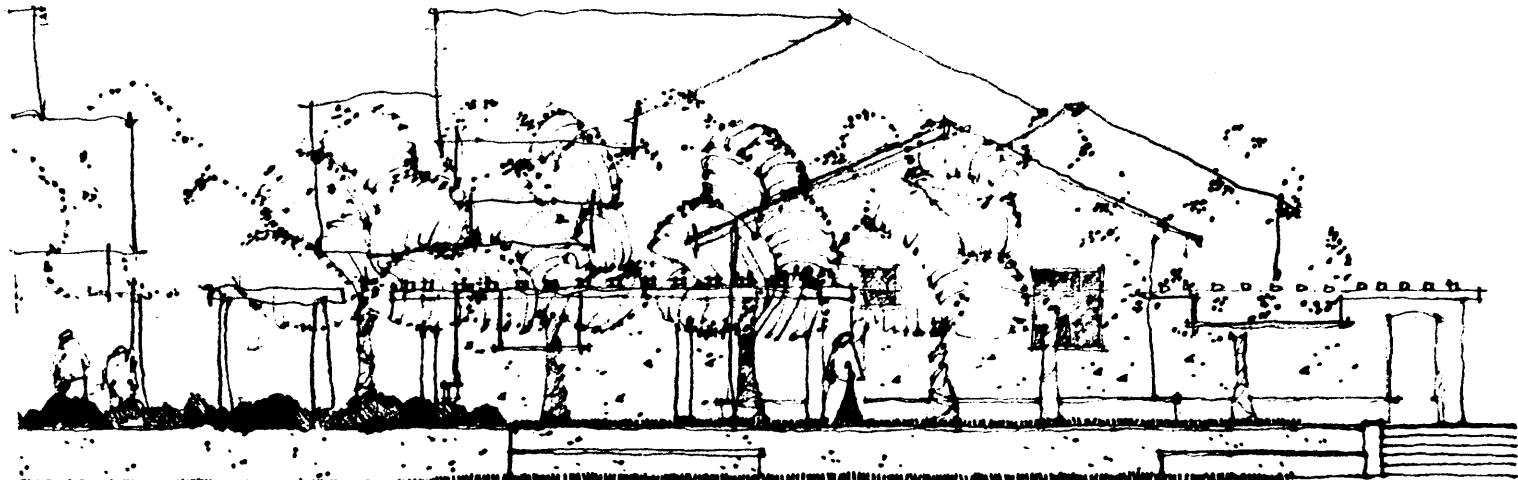
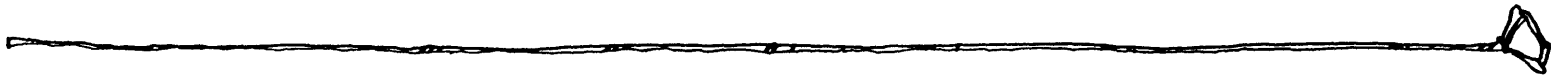

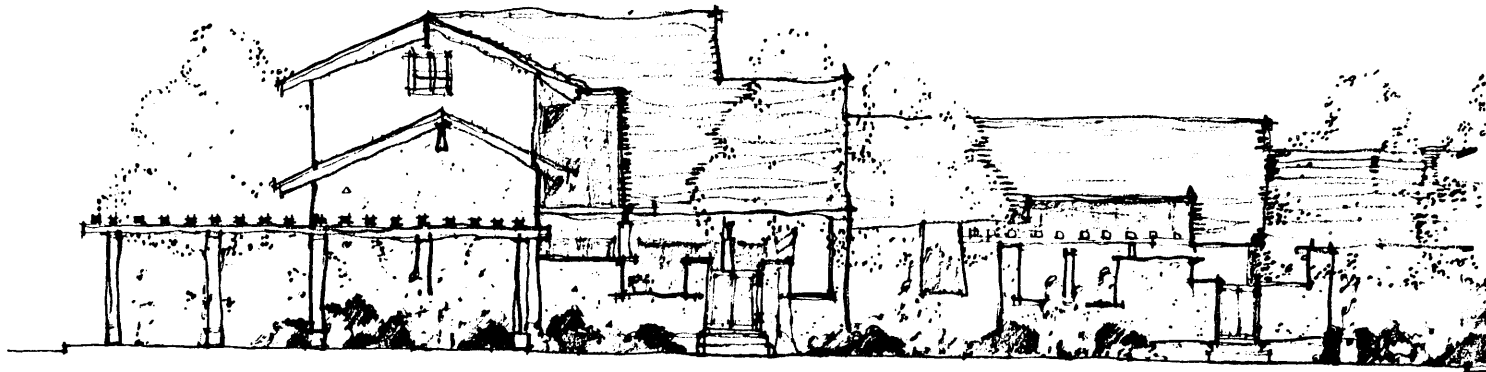
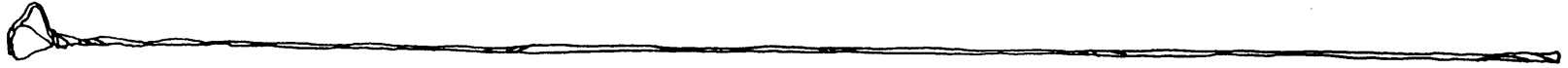

LONG SECTION THROUGH CLUSTER



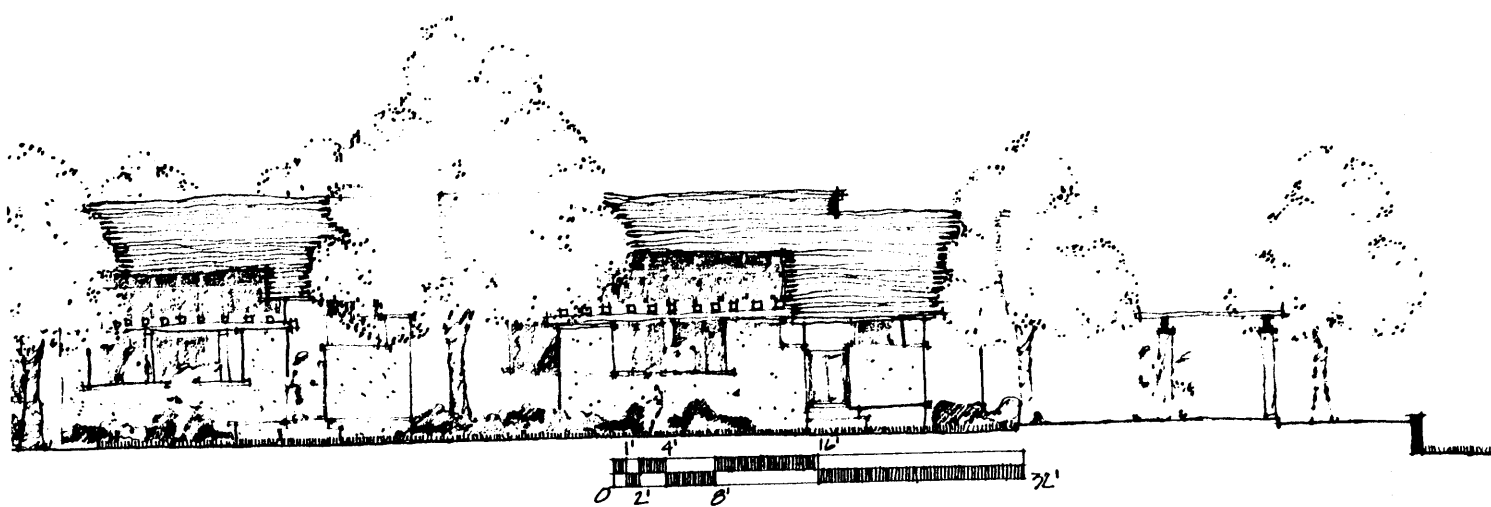

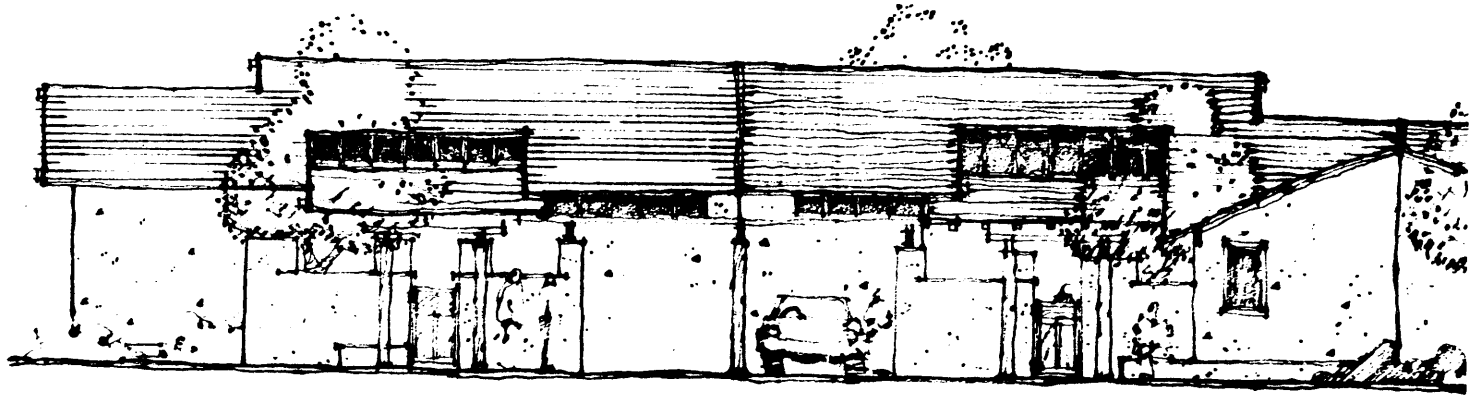
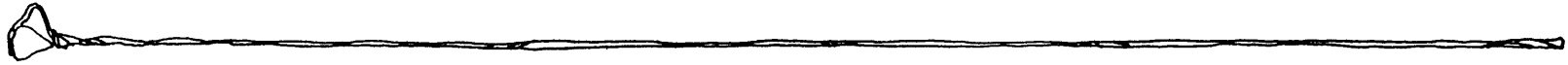

STREET ELEVATION

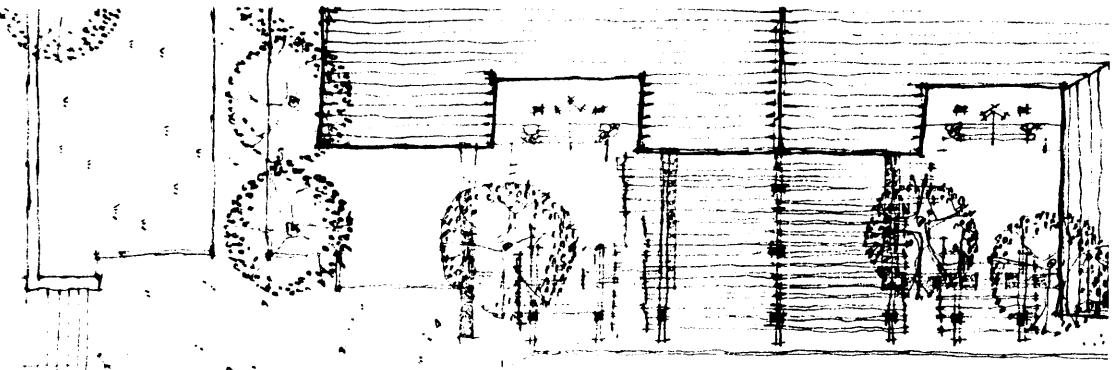

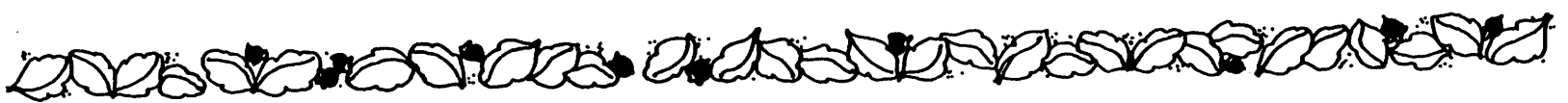
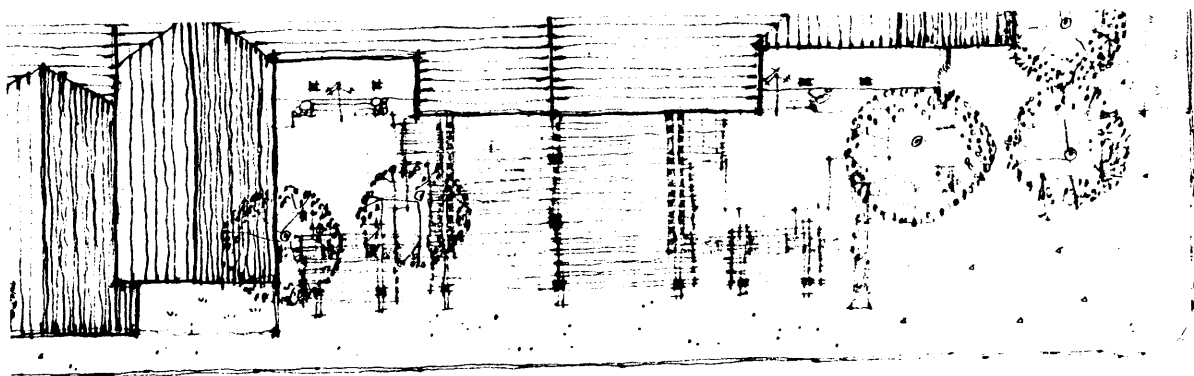
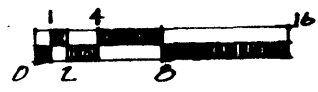
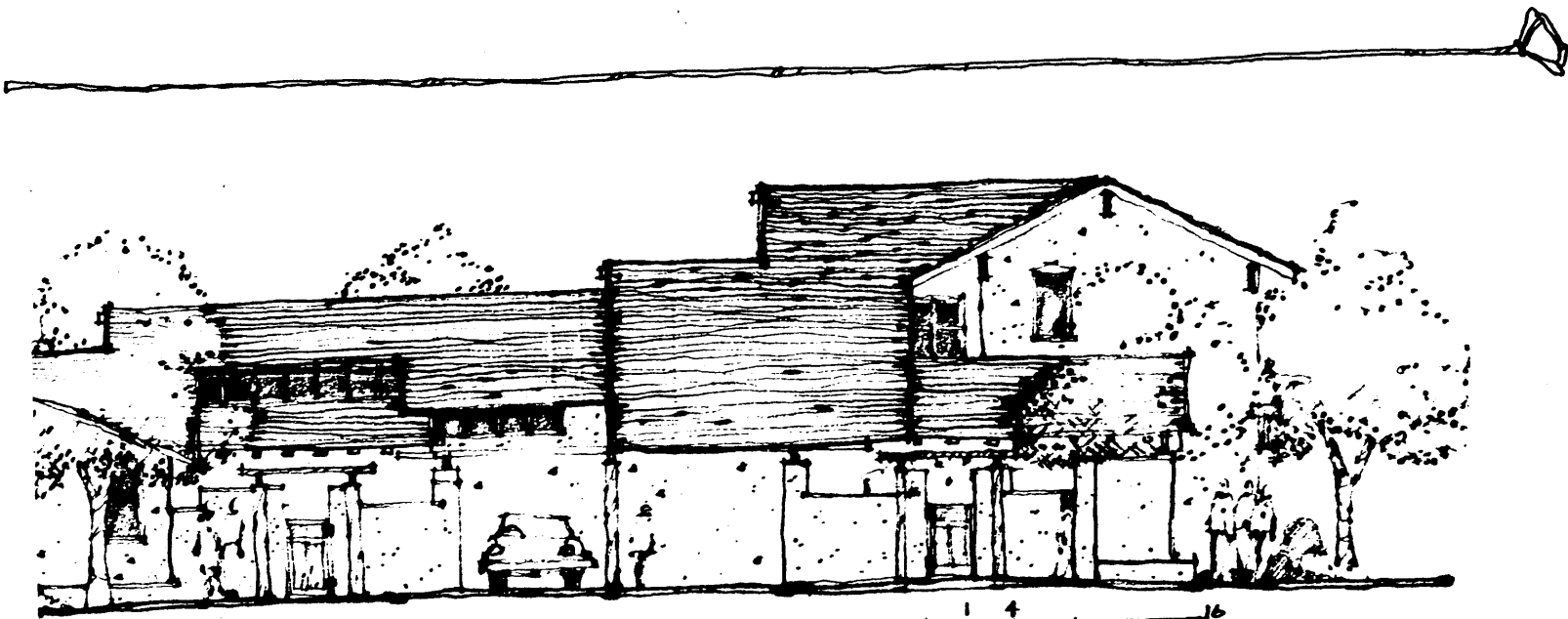



## CONCLUSION

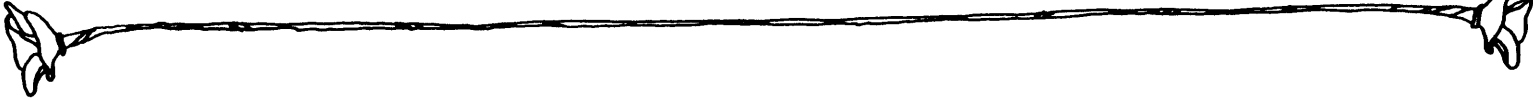

The success of my design is a determination best settled by critics other than myself. It is my task to question and assess whether the principals defined in the design framework were correct. Indeed, after testing and manipulating them it is my responsibility to determine the viability and appropriateness of using such a framework for contemporary design.

Traditionally adobe buildings were designed for a single community. The form expressed a single, albeit great, privacy hierarchy. Thus today it would be easiest to apply this hierarchy to single use building such a library, school, single family detached home, etc... The challenge arose in applying



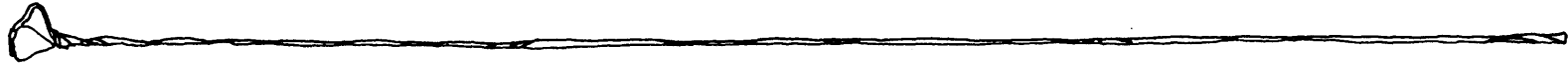

this framework to a problem with new constraints. The project required building high density housing in a rural setting. References existed for each singularly but not together. Thus, the solution was not obvious and had to be derived from a thorough understanding of each situation.

Then there are practical considerations. The viability of modern construction with adobe is assumed. Its use, while not frequent, is not uncommon. But limited labor skilled in adobe construction techniques, and difficulty amassing great quantities of adobe bricks fuels the argument that building 28 adobe homes concurrently may be unrealistic.

Ideological and practical difficulties aside, the exercise in exploring and understanding a buildings form was of unquestionable worthiness. It is clear that many of the principals defined, and innovations proposed are relevant and viable using any construction technology. The lessons on how to integrate the indoors and the outdoors, how to create hierarchies of privacy and light, how to manipulate the weather, how to define a building edge, and many more lessons are worthwhile to bring to all design solutions.



## BIBLIOGRAPHY

### ADOBE TECHNOLOGY

"Adobe News". P.O. Box 702, Los Lunas, New Mexico. 87030

"Adobe... Part of Western Tradition". Sunset. 126 (5): 108-115. May 1961. Lane publishing Co. Menlo Park, California.

Foudreau, E.H. Making the Adobe Brick. Berkeley.: Fifth Street Press 1971

Clifton, James. Methods for Characterizing Adobe Building Materials. MIT Thesis, 1978.

Dethier, Jean. Down to Earth: Adobe Architecture: An Old Idea, a New Future.

Eccli, Eugene. Low Cost, Energy Efficient Shelter for the Owner and Builder. PP 61-67. Emmaus, Penn. Roadale Press, 1975.

Fathy, Hassan. Architecture for the Poor. Chicago, University of Chicago Press, 1973.

Garrison, Paul. How to Build Adobe Houses. 1979.

Hans Sumpf Company. Adobe. Fresno, California. The Co. 1976.

Harrington, Mark R. How to Build a California Adobe. Los Angeles: Ward Ritchie Press, 1948.

Hinchcliff, Keith H. Leader Training for Aided Self Help Housing. AID, Washington, D.C., U.S. Department of State. 1971.



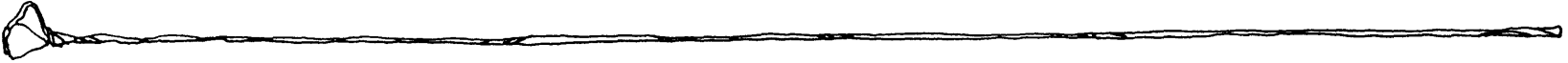

Long, James. "Adobe Structures for Earthquake Regions." 8(7): 173-4  
(July 1927).

Long, James. Adobe Construction. College of Agriculture, California  
Agricultural Experiment Station Bulletin 472. Berkeley. University of  
California Press, 1946;

McHenry, Paul Graham. Adobe, Make it Yourself. 1973.

Mud, Space and Spirit: Handmade Adobes. 1976

Newcomb, Duane G. The Owner Built Adobe House.

Palmer, Richard. Adobe Housing Use Benefits and Thermal Properties.  
Irvine, California. The Company. 1974.

Pearce, George William. Six Room House for \$2,800...

Schultz, Karl. Adobe Craft: Illustrated Manual. Castro Valley,  
California. Adobe Craft Press. 1972.

Southwick, Marcia. Build with Adobe. Chicago.: Sage Books, 1965.

Stedman, Myrtle. Adobe Architecture. Santa Fe. Sunstone Press, 1973.

"Study Eyes Bigger Role for Adobe in Low Cost Housing". Engineering  
News Record. 178(2):37. Jan. 5, 1967.

Turner, John. Adobe: Techniques and Architecture. Dec 82-Jan 83. No.  
345.

UBC. "Unburned Clay Masonry" pp. 158-9. Whittier, Calif. Int. Conf of  
Building Officials. 1976.

---

"Adobe Bibliography" Bulletin of the Association for Preservation  
Techniques. V.4 (1973) 97-103.

Barnes, M.R. "Adobe Bibliography", Bulletin of the Association for  
Preservation Techniques. VII.II (1975) 89-101.

Henning, J.C. "Literature of Adobe, A Brief Bibliography." Calif.  
Librarian 33.3 (July 1972) 183-184.

Hopson, Rex C. Adobe: A Complete Bibliography. 1979.



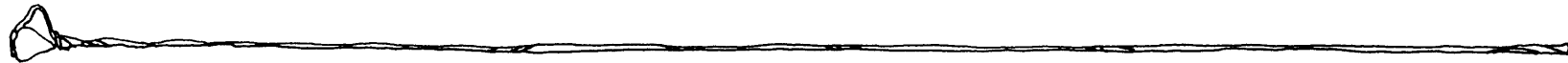

CALIFORNIA ARCHITECTURE

Anderson, Timothy J. Editor. California Design. 1910. Santa Barbara California.: Peregrine Smith, Inc. 1980.

Andree, Herb. Santa Barbara Architecture From Colonial to Modern.

Bangs, Geoffrey E. Portals West. H.S. Crocker & Co. Inc. San Francisco California Historical Society. Distributed by: Lane Publishing Co. Sunset Books. Menlo Park, California.

Bohn, Dave and the Junior League of Oakland. East of these Golden Shores: Architecture of the Earlier Days of Contra Costa and Alameda Counties. Scrimshaw Press. 1971.

Bruegmann, Robert. Benicia.

Cardwell, Kenneth H. Bernard Maybeck. Salt Lake City.: Peregrine Smith Books, 1983.

Fitzgerald, Kathleen. Architecture Napa: Guide to the Land, Buildings and Style of Napa.

Kirker, Harold. California Architectural Frontier. Santa Barbara.: Peregrine Smith Books. 1973.

Lewis, Oscar. Here Lived the Californians. New York. Rinehart, 1957.

Makinson, Randell L. Green and Green, Architecture as a Fine Art. Sal Lake City.: Peregrine Smith Books, 1977.

McCoy, Esther. Five California Architects. New York. Praeger Publishers 1975.



---

HISTORIC, NON-ECCLESIASTICAL CALIFORNIA ADOBE ARCHITECTURE

Baer, Kurt. Architecture of the California Missions. 1958.

Baer, Morley. Adobes in the Sun. San Francisco.: Chronicle Books, 1972.

Bauer, Helen. California Rancho Days, A Guide to Adobes and Landmarks of Rancho Days. pp. 110-25. Garden City, N.Y. Doubleday & Co. 1953.

Brown, F.W. California Homes-Adobe House Edition. San Francisco.: Home Book Publishing Co. 1948. 30 pp.

California Historic Landmarks: California Division of Beaches and Parks 1936.

Clark, David E. Editor. The California Missions. Menlo Park, California Lane Publishing Co. 1979.

Comstock, Helen. "California Adobes". in Great Houses From the Pages of the Magazine Antiques. By Constance M. Greiff pp. 376-80. New York, Weathervane Books, 1973.

De Long, David G. Historic American Buildings: California. Volumes I and II. New York. Garland Publishing Inc. 1980.

Fenyés, Eva Scott. Thirty Two Adobe Houses of Old California Reproduced From Watercolor Paintings. Los Angeles. Southwest Museum. 1950.

HABS. Catalog of Measured Drawings. National Park Service. With supplement.





Hannaford, Donald R. Spanish Colonial or Adobe Architecture of California, 1800-1850. N.Y. N.Y. Architectural Book Publishing Co. 1931.

Hendry, George Whiting and J.N. Bowman. The Spanish and Mexican Adobe and Other Buildings in Nine San Francisco Bay Counties. 1776 to About 1850 (Manuscript) Bancroft Library. University of California, Berkeley. 1940. 7 Volumes. 1450 pp.

Giffen, Hellen Smith. Casas and Courtyards: Historic Adobe Houses of California. California Relations. No. 40. Oakland: Biobooks. 1955.

Lumpkins, W.T. La Casa Adobe. Santa Fe. Ancient City Press. 1961.

Newcombe, Rexford. The Old Mission Churches and Historic Houses of California. Philadelphia. J.B. Lippincott Co. 1925.

Santa Fe Museum of New Mexico. Adobe Past and Present. Museum of New Mexico. Santa Fe. Box 2087, 87501. \$150. 1972.

Stedman M. and W. Adobe Architecture. Santa Fe. Sunstone Press 1973.

\_\_\_\_\_, Of Earth and Timbers Made





ARCHITECTURE THEORY

Alexander, Christopher. A Pattern Language. New York. Oxford University Press. 1977.

\_\_\_\_\_. The Timeless Way of Building. New York. Oxford University Press. 1979.

Norberg-Schulz, Christopher. Genus Loci: Toward a Phenomenology of Architecture. New York. Rizzoli. 1979.

Rudofsky, Bernard. The Prodigious Builders. New York. Harcourt Brace, Jovanovich, 1977.





LANDSCAPE THEORY

Jackson, J.B. Landscapes. Amherst. The University of Massachusetts Press. 1970.

\_\_\_\_\_. The Necessity for Ruins. Amherst. The University of Massachusetts Press. 1980.

Meinig, D.W. Editor. The Interpretation of Ordinary Landscapes. New York, Oxford University Press. 1979.

Stilgoe, John R. Common Landscapes of America. New Haven, Yale University Press. 1982.

Zelinsky, Wilber. The Cultural Geography of the United States. Englewood Cliffs, N.J. Prentice-Hall, Inc. 1973.



