

**AN EXPERIMENTAL STUDY OF
THE EFFECT OF SHARED INFORMATION
ON PILOT/CONTROLLER
RE-ROUTE NEGOTIATION**

Todd C. Farley and R. John Hansman, Jr.



MIT International Center for Air Transportation
Department of Aeronautics & Astronautics
Massachusetts Institute of Technology
Cambridge, Massachusetts USA

January 1999
ICAT-99-1

AN EXPERIMENTAL STUDY OF THE EFFECT OF SHARED INFORMATION ON PILOT/CONTROLLER RE-ROUTE NEGOTIATION

Abstract

Air-ground data link systems are being developed to enable pilots and air traffic controllers to share information more fully. The sharing of information is generally expected to enhance their shared situation awareness and foster more collaborative decision making.

An exploratory, part-task simulator experiment is described which evaluates the extent to which shared information may lead pilots and controllers to cooperate or compete when negotiating route amendments. The results indicate an improvement in situation awareness for pilots and controllers and a willingness to work cooperatively.

Independent of data link considerations, the experiment also demonstrates the value of providing controllers with a good-quality weather representation on their plan view displays. Observed improvements in situation awareness and separation assurance are discussed. It is argued that deployment of this relatively simple, low-risk addition to the plan view displays be accelerated.

This document is based on the thesis of Todd Farley, submitted in partial fulfillment of the degree of Master of Science in Aeronautics & Astronautics at the Massachusetts Institute of Technology.

Acknowledgements

This work was supported by the National Aeronautics and Space Administration Ames Research Center under grant NAG 2-716 and by The Analytical Sciences Corporation (TASC) as part of the FAA Center of Excellence in Operations Research.

The authors would like to acknowledge the following people for their contributions to this study:

- Dr. Sandra Lozito and Dr. Kevin Corker of NASA–Ames for their support and expertise.
- Dr. Mica Endsley of SA Technologies for her insights and contributions throughout this study.
- Mr. John Ladik, Ms. Dana Sherer and Mr. Jack Oswald at TASC for their support.
- The six professional pilots and six air traffic control specialists who generously gave their time, interest and expertise to this experiment.
- The following personnel with the FAA for their enthusiastic support: Joe Davis, Larry Doty, Ed Green, Bob Adelizzi, Bill Johannes (NATCA), Bryan Thompson (NATCA Voice), and Wier Lundgren (NWS). Special thanks to John Melecio.
- Keith Amonlirdviman, Steve Landry and Laurence Vigeant-Langlois of MIT ICAT for their exceptional efforts which made this experiment possible.

Table of Contents

Abstract.....	iii
Acknowledgements.....	v
Table of Contents.....	vii
Acronyms & Abbreviations	ix
Chapter 1 Introduction.....	1
Chapter 2 Situation Awareness Analysis.....	5
2.1 Situation Awareness Model.....	5
2.2 Comparative SA Analysis Between Pilots and Controllers.....	8
2.2.1 Methodology	8
2.2.2 Results.....	11
Chapter 3 Part-Task Simulator Study	15
3.1 Objectives	15
3.2 Approach.....	16
3.3 Test Matrix.....	16
3.4 Independent Variable: Presence of Data Link	17
3.5 Test Scenarios	21
3.5.1 Airspace Sector	22
3.5.2 Traffic Flow	23
3.5.3 Weather Elements.....	24
3.5.4 Scenario Design.....	24
3.5.4.1 Use of Repeated Scenarios.....	24
3.5.4.2 Scenario 1.....	27
3.5.4.3 Scenario 2.....	29
3.5.4.4 Scenario 3.....	31
3.6 Protocol.....	31
3.6.1 Test Facility.....	31
3.6.1.1 Advanced Cockpit Simulator (ACS)	33
3.6.1.2 Air Traffic Control Simulator	35

3.6.1.3	Pseudo-Aircraft Simulator and Control Station	37
3.6.1.4	Scenario Design Tool.....	40
3.6.2	Subjects.....	40
3.6.3	Procedure	41
3.6.3.1	Preliminary Briefings and Training.....	41
3.6.3.2	Formal Testing.....	42
3.6.3.3	Debriefing	43
3.6.4	Metrics and Data Analysis.....	43
Chapter 4	Results.....	47
4.1	Situation Awareness	47
4.1.1	Testable Response Data.....	47
4.1.2	Controllers' Weather Awareness Data	49
4.2	Separation Violations	60
4.3	Communication and Negotiation	66
4.4	Workload	68
4.5	Subjective Responses	69
4.6	Discussion.....	69
Chapter 5	Conclusions.....	73
References.....	75
Appendix A	Commercial Airline Pilot Goal Hierarchy	77
Appendix B	Commercial Airline Pilot Situation Awareness Information Requirements.....	83
Appendix C	Initial Briefing Materials.....	89
Appendix D	Training Materials	93
Appendix E	Voice Coding Worksheet.....	100
Appendix F	NASA Task Load Index Survey Materials	102

Acronyms & Abbreviations

ACS	Advanced Cockpit Simulator
AOC	Airline Operations Center
ARTCC	Air Route Traffic Control Center
ATC	Air Traffic Control
ATP	Air Transport Pilot
AWIN	Aviation Weather Information
CID	Computer Identification Number
CDU	Control and Display Unit
CDTI	Cockpit Display of Traffic Information
CPA	Closest Point of Approach
CRD	Computer Readout Display
DBZ	Decibels
DEC	Data Entry Control
DQN	Dayton VOR
DSR	Display System Replacement
EFIS	Electronic Flight Instrument System
EHSI	Electronic Horizontal Situation Indicator
FAR	Federal Aviation Regulation
FDY	Findlay VOR
FLCH	Flight Level Change
FMS	Flight Management System
FPL	Full Performance Level
FWA	Fort Wayne VOR
Hz	Hertz
ICAT	International Center for Air Transportation
LNAV	Lateral Navigation
MCP	Mode Control Panel
MIE	Muncie VOR
NAS	National Airspace System

NASA	National Aeronautics and Space Administration
NASA-TLX	NASA Task Load Index
NATCA	National Air Traffic Controllers' Association
NEXRAD	Next Generation Weather Radar
n.m.	nautical miles
NWS	National Weather Service
PFD	Primary Flight Display
PIREP	Pilot Report
PVD	Plan View Display
SA	Situation Awareness
SATCOM	Satellite Communications
SGI	Silicon Graphics, Incorporated
SHB	Shelbyville VOR
TAS	True Airspeed
TCAS	Traffic alert / Collision Avoidance System
TDLS	Tower Data Link Services
TWIP	Terminal Weather Information for Pilots
UTC	Universal Time Coordination
VHP	Indianapolis VOR
VNAV	Vertical Navigation
VOR	Very-high frequency Omnidirectional Range
WARP	Weather and Radar Processor
XPDR	Transponder
ZID	Indianapolis Air Route Traffic Control Center (a.k.a. Indy Center)

Chapter 1 Introduction

The technology to deliver digital data link communication between aircraft and the ground is well developed. Current data link applications include pre-departure clearance delivery via Tower Data Link Services (TDLS), global voice and data communications via satellite (SATCOM), and weather uplinks via Terminal Weather Information for Pilots (TWIP). The FAA's proposed future National Airspace System Architecture (FAA, 1998c) calls for expansion of existing data link services to include applications such as the Controller–Pilot Data Link Communication (CPDLC) system, Automatic Dependent Surveillance broadcasts (ADS-B), and Aviation Weather Information (AWIN) systems.

Such advances will allow information which is not uniformly accessible today to be shared between pilots, controllers and other users (e.g., dispatchers, airport managers, etc.). This sharing of information—an information "party line"—is expected to offer several benefits:

- Improved shared situation awareness between agents;
- The ability to better anticipate the needs and/or preferences of other agents;
- A common informational context upon which to negotiate.

These benefits ultimately are expected to result in more cooperative interaction between agents, moving airspace operations closer to the envisioned goal of Collaborative Decision Making (CDM) (Falcone, *et al.*, 1998).

However, the sharing of information may effect a less desirable outcome, one characterized by increased voice communications, increased workload, and increased contention between agents. Midkiff & Hansman (1992) found that pilots were more willing to comply with air traffic control (ATC) when they knew their own information to be inferior to that of ATC. Conversely, they found that pilots were more assertive and willing to question ATC when they knew their own information to be equal or superior to that of ATC.

The implementation of digital data link stands to alter the current "balance of information" between ATC and the flight deck. Today, flight crews typically have better weather information than air traffic controllers, while air traffic controllers typically have better traffic information than the flight crews. These imbalances lend stability to a control system which is inherently ambiguous with regard to authority: controllers are responsible for ensuring aircraft

separation (FAA, 1998b), but pilots are responsible for the operation of their aircraft (FAA, 1998a). In practice, controllers typically defer to flight crews in matters involving hazardous weather. Conversely, flight crews typically defer to air traffic control in matters involving traffic conflicts. In effect, authority is assigned implicitly based on the information allocation—the agent with the better information assumes authority. Since the information superiority with regard to weather and traffic is unambiguous, so too is the decision-making authority in weather- and traffic-related situations.

By sharing weather and traffic information between both parties, data link applications will work to redress the current information imbalances. For example, a shared representation of convective weather activity may enable controllers to better recognize developing weather constraints, anticipate needed deviations, and reorganize the traffic flow earlier and more effectively. Similarly, a shared representation of traffic information will provide pilots a fuller picture of their surrounding traffic flow, consistent with the information available to ATC. This may enable pilots to better anticipate sequencing instructions, correlate PIREPs, and identify available route alternatives.

However, by sharing information, the stability of the system may actually be undermined. Sharing information will serve to neutralize any current information advantage—the basis on which authority is presently assumed—effectively putting decision-making authority "up for grabs". The results of Midkiff & Hansman (1992) suggest that in some situations the availability of common information via data link may result in increased negotiation, and with it commensurate increases in frequency congestion and workload. In short, it suggests the potential for less collaborative, less efficient operations.

The present study adopted an integrated human-centered systems approach to evaluate the effect of an air–ground data link system on pilot–controller interaction. The approach considered the human elements of the system as functional components of a closed-loop control system (Hansman, *et al.*, 1997). The following four-step process formed the basis of the overall system performance assessment:

- Step 1. Determine the goal structures and situation awareness information requirements of pilots and air traffic controllers.

- Step 2. Compare pilots' and controllers' goal hierarchies and information requirements to identify areas of common, disparate or competing interest.
- Step 3. Based on the findings, design and perform simulator-based test scenarios which explore pilots' and controllers' interactions and behaviors in environments where common information may serve competing goals.
- Step 4. Based on the experimental observations, assess the potential benefits and effects of shared information at the system level.

In order to understand the effect of shared information in the system and how pilots and controllers may act on that information, it was necessary first to identify their roles, their motives and their informational needs (Step 1). A comprehensive goal-directed task analysis was performed for commercial airline pilots (Endsley, Farley, Jones, Midkiff, & Hansman, 1998) to complement an existing analysis for en route ATC specialists (Endsley & Rodgers, 1994). The two analyses then were compared against one another in order to identify areas of common or competing interest between pilots and controllers (Step 2). This effort is detailed in Chapter 2.

Based on the results of the comparative analysis, an exploratory, part-task simulator experiment was conducted to evaluate the extent to which shared information (via air-ground data link) may lead pilots and controllers to cooperate or compete when negotiating route amendments (Step 3). The experiment paired an airline pilot subject with an ATC specialist subject in a real-time simulated air traffic environment. Test scenarios intentionally conflicted the goals of pilot and controller in tactical re-routing situations as identified in the comparison of the pilot and controller task analyses. Of particular interest were indications of each subject's recognition of the other's constraints, anticipation of others' needs and preferences, willingness to comply/cooperate, and persistence in pursuing one's own preferred solution. The experiment is detailed in Chapter 3.

Chapter 4 presents the experimental results in terms of situation awareness, separation assurance, pilot-controller interaction, and workload.

Chapter 5 summarizes the overall findings of this study (Step 4). It assesses the potential for shared information to effect more collaborative or competitive interaction between pilots and controllers and discusses the safety implications and low-risk steps to improve the system.

Chapter 2 Situation Awareness Analysis

In order to assess the effects of shared information on pilot–controller interaction, it was necessary first to understand their individual interests and information requirements, as well as their common ones. Endsley & Rodgers' (1994) analysis of en route air traffic control specialists created a goal hierarchy and a list of situation awareness information requirements for the task of en route air traffic control. For the present study, a similar methodology was applied to the job of commercial airline pilots, facilitating a comparison between the two.

This chapter begins with a brief introduction to the concept of situation awareness, describing the Endsley hierarchical model of situation awareness (SA) and the role of SA in the decision-making process. The development of a pilot task analysis is described which parallels the existing controller task analysis, identifying the pilot's goal structure and SA information requirements. Finally, a comparison of the two analyses is presented along with the conclusions it supports.

2.1 Situation Awareness Model

Situation awareness is a fundamental requirement for most complex tasks, forming the basis for decision making and performance. While there are several acceptable definitions of situation awareness, the definition most applicable for this study comes from Endsley (1995):

"Situation awareness is the perception of the elements in the environment within a volume of time and space, the comprehension of their meaning, and the projection of their status in the near future."

The definition casts situation awareness in a hierarchical form. At the lowest level, Level 1, is the "perception of the elements". This includes the status, attributes, and dynamics of the relevant elements of one's environment. Having perceived such elements, the next level of SA is the "comprehension of their meaning". This second level of SA requires the individual to integrate disjointed Level 1 elements to understand their significance relative to his goals. Inherent in Level 2 SA is the ability to recognize the impact of a change in one element on another, the ability to detect errors in the system, and the ability to derive rates from raw data. The highest

level, Level 3, is the "projection of their status in the future". It is the ability to accurately predict the future actions of the elements and the future state of the system over the near term. It is this level of SA that provides the decision maker with the time to develop and consider alternative courses of action.

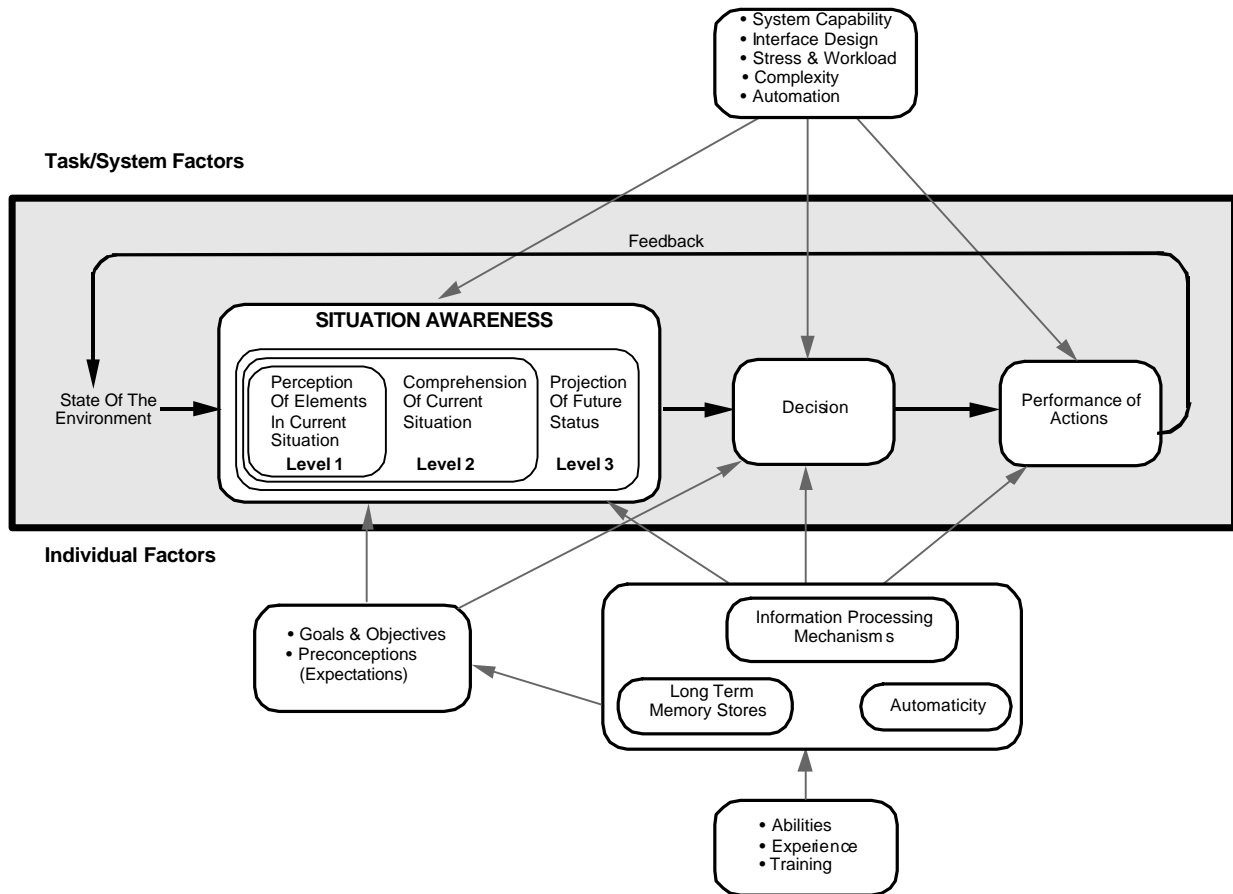


Figure 1. Model of situation awareness in decision making (from Endsley, 1995)

Figure 1 illustrates the role of situation awareness in the decision-making process. While decisions may be affected by static factors such as rules, equipment, or training, it is one's situation awareness that forms the critical dynamic input to the decision process and subsequent action. It is important to recognize that SA is heavily affected by individual factors, principally the goals, objectives and preconceptions of the decision maker.

In air traffic operations, decisions typically involve two or more individuals: pilot, controller, dispatcher, etc. The Endsley SA model can be extended to accommodate such "group decisions" by incorporating parallel feedback paths, one for each decision maker. Figure 2

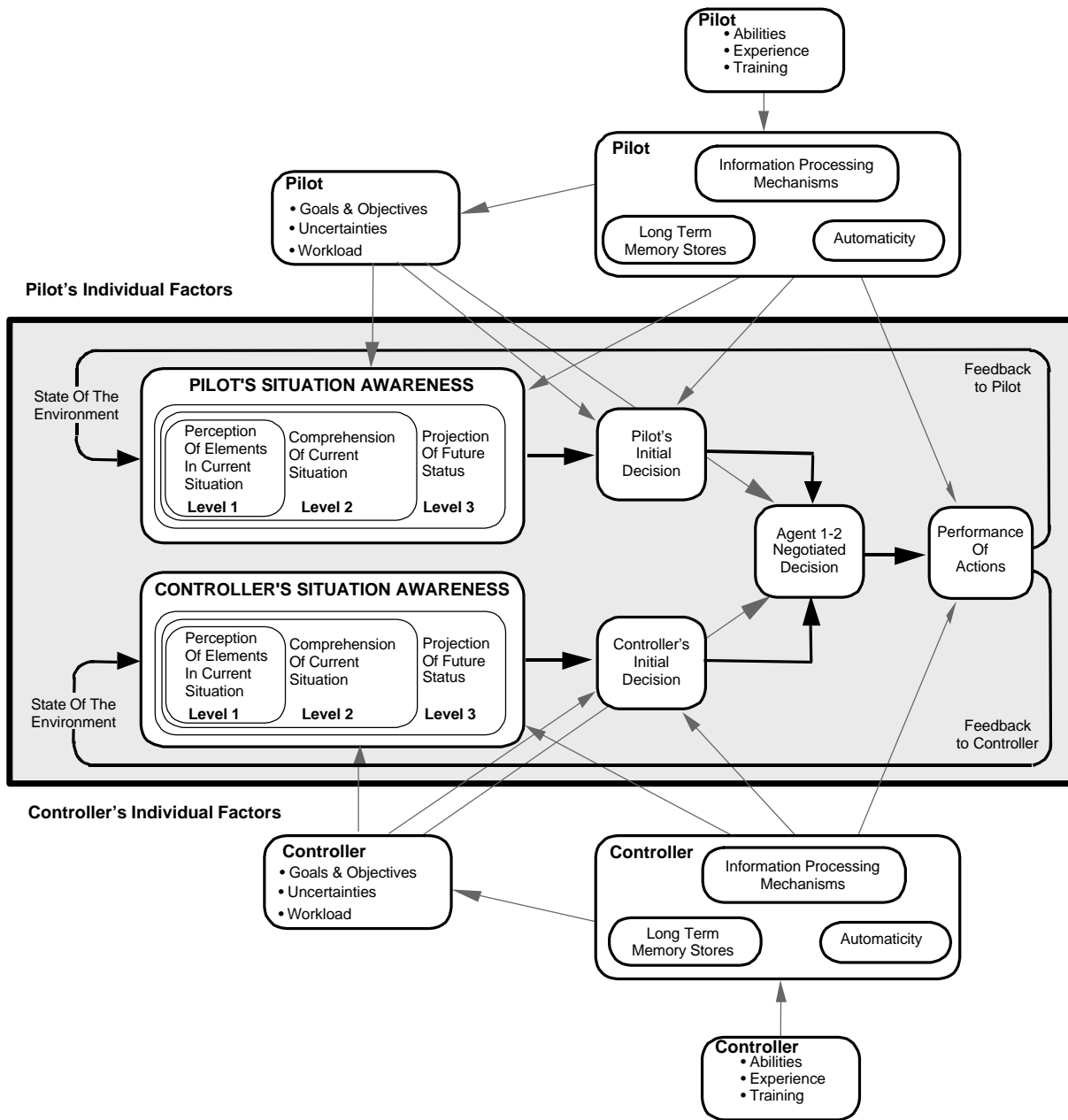


Figure 2. Model of situation awareness in group decision making

depicts the model for a pilot-controller decision-making group. Note that each decision maker has an independent feedback loop, which may contain different information elements about their common environment. Each person interprets his available information (biased by his individual goals), acquires some level of SA, and arrives at an initial decision that will support his objectives. This initial decision may differ from his counterpart. After a period of negotiation, a final decision is reached and an action is taken. The amount of negotiation that takes place is

dependent on factors such as the alignment of the negotiators' goals, the relative uncertainty of their information, and their respective workload levels. The negotiation period may be brief or nonexistent if, for example, both parties arrive at the same initial decision or if one individual's high workload precludes negotiation. The negotiation period may be protracted if their goals are mutually exclusive, high in priority, and each individual has a high degree of confidence in his information.

The Group SA model illustrates how disparate goals and objectives and/or unequal information about the state of the environment may affect the negotiation process by virtue of their unique effect on each person's individual level of situation awareness.

2.2 Comparative SA Analysis Between Pilots and Controllers

Lewicki, Saunders, & Minton (1997) assert that negotiation arises when two parties have competing goals and at least one party believes he can exert some form of influence to gain a more favorable resolution. In examining negotiation between pilots and controllers, then, it is important to understand where their goals are in common and where they are in competition. Furthermore, since information is a common source of power in negotiation (Lewicki, Saunders, & Minton, 1997), it is important to consider disparities in their available information and how the balance of information may affect the balance of power in pilot-controller negotiations.

2.2.1 Methodology

To identify the common and competing goals of controllers and pilots and to determine where their respective information advantages lie, an analysis was performed comparing the goals and information requirements of en route air traffic controllers against those of commercial airline pilots. Controller goals and information requirements were taken from a task analysis by Endsley & Rodgers (1994). Because no such task analysis existed for commercial airline pilots, one was performed as part of this study (Endsley, Farley, Jones, Midkiff, & Hansman, 1998).

Pilot goals and information requirements were identified by conducting a goal-directed task analysis based on elicitation from experienced commercial airline pilots. The analysis was performed based on the methodology of Endsley & Rodgers (1994). To start, each expert was asked to identify his top-level goal when in command of a commercial airline flight. Once this

initial goal was articulated, the remainder of the analysis proceeded in recursive fashion as follows. The pilot was asked:

Step 1. What assessments must be made to accomplish this goal?

Step 2. What information is required to make those assessments?

Step 3. What lower-level goals ("sub-goals") contribute to the goal currently under consideration?

These three questions were repeated for each listed sub-goal until that branch of the hierarchy was exhausted. The analysis then progressed laterally to develop the remaining branches of the hierarchy.

For example, when assessing the flight plan, pilots specified "avoiding hazardous weather" as a goal. For step 1—"What assessments must be made to accomplish that goal?"—pilots itemized three basic considerations:

(a) *Is hazardous weather expected en route?*

(b) *What is the degree of hazard of anticipated weather conditions?*

(c) *Is a change of flight path needed?*

For step 2, pilots identified numerous information items required to make these assessments. For instance, with respect to question (a), the information requirements in Table 1 (next page) were cited¹:

¹ The list is hierarchical. Indented items indicate more specific or lower-level information inherent to the higher-level information listed above it.

Table 1. Example information requirements

<p>Sub-goal: Avoid hazardous weather</p> <ul style="list-style-type: none">▪ <i>Is hazardous weather expected en route?</i><ul style="list-style-type: none">▪ Likelihood of hazardous weather encounter▪ Planned flight path▪ Current weather pattern and conditions▪ Area affected▪ Altitudes affected▪ Projected weather conditions▪ Direction and speed of movement▪ Increasing or decreasing intensity▪ Confidence level in weather information

For this example, no subgoals were identified in accordance with step 3, so the analysis moved on to repeat step 2 for question (b), and so forth.

The process to completely specify the entire goal hierarchy with all of its attendant assessments and information requirements comprised numerous interview sessions with subject matter experts. Each expert was interviewed individually. Interview sessions lasted from one to four hours. Two active airline pilots served as subject matter experts. Their average flight experience was 9,350 flight hours, encompassing regional, domestic, international and military operations. The initial draft was reviewed for accuracy and completeness by six other airline pilots (mean flight hours: 10,580). Their comments were incorporated into the final analysis.

The pilot goal hierarchy is provided in Appendix A; the list of SA information requirements is found in Appendix B. The requirements are organized by SA level: perception of elements (Level 1), comprehension of their meaning (Level 2), and projection of the future (Level 3).

The completed commercial airline pilot task analysis was then compared against the Endsley & Rodgers (1994) air traffic controller task analysis to identify areas in which the goals of pilots and controllers could be in competition and to identify the important information

elements in those areas. The results were expected to reveal situations in which the sharing of information between pilot and controller (via data link) could have an observable effect on system stability and efficiency.

The top levels of the goal hierarchies were compared to identify common elements. The structure of each hierarchy was reworked around those common elements to better facilitate direct comparisons between the two. The syntax of some elements was revised to be comparable. Based on their aligned goals, the underlying assessments and information requirements were compared to identify common and unique elements. Common information requirements were further examined for their potential to support competing goals between pilots and controllers.

2.2.2 Results

Figures 3 and 4 depict the high-level goals of pilots and controllers, respectively. At these higher levels, the goal structures are highly parallel, and there is considerable overlap between the two. Common interests include such goals as:

- Assure flight safety
- Avoid conflicts (e.g., aircraft, terrain, restricted airspace)
- Assess current and alternate routes
- Provide customer service
- Handle perturbations (e.g., weather, emergencies)
- Manage resources (e.g., people, systems)

The comparative analysis illustrates the far-reaching effects of re-route decisions. All of the first- and second-level goals for both pilots and controllers are influenced by the current and future flight path. This suggests that re-route negotiations have broad and significant ramifications for both pilots and controllers and that each should have a vested interest in the outcome.

Comparison of the lower-level goals reveals that pilots and controllers often have competing interests with respect to re-route decisions. In considering a route deviation, pilots and controllers often perform an informal cost/benefit analysis, weighing the benefit in terms of their mission objectives against the cost in terms of workload. However, comparison of the task analyses indicates that pilots and controllers calculate the costs and benefits differently.

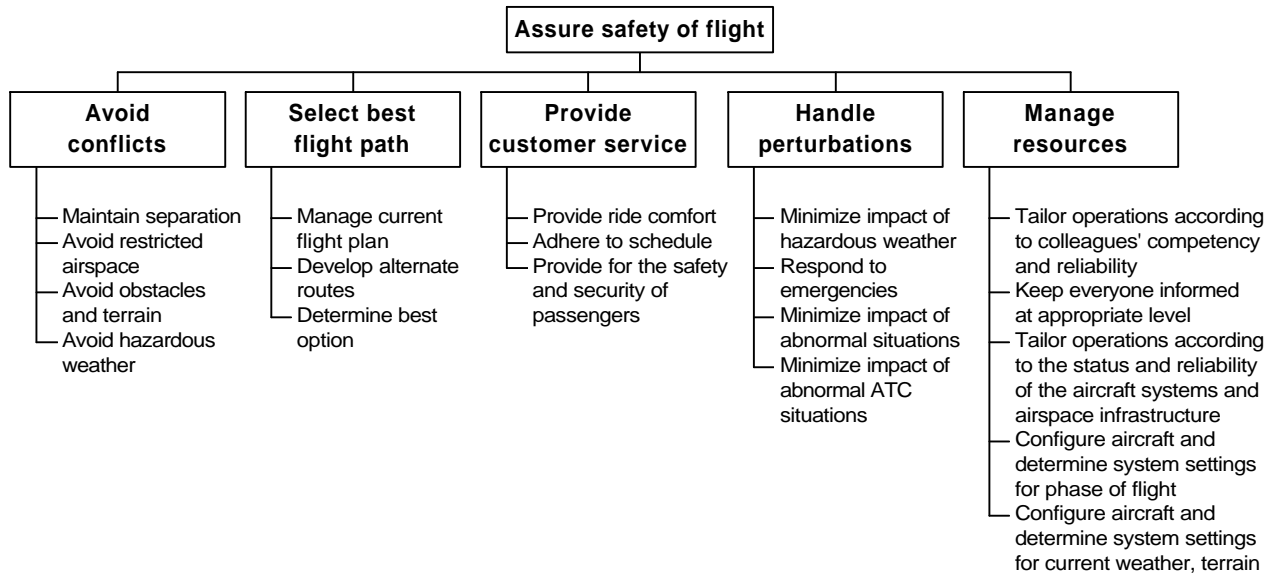


Figure 3. Commercial airline pilot top-level goal hierarchy

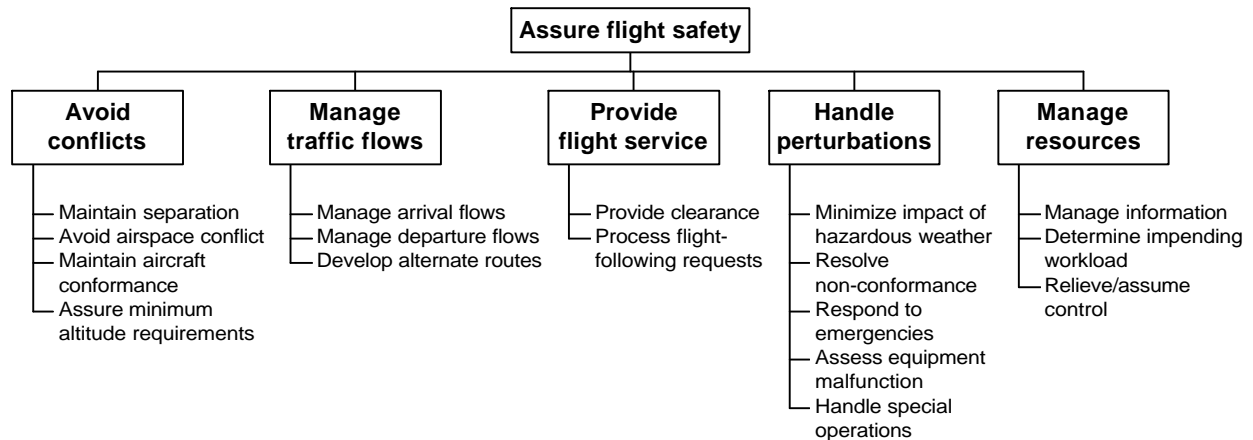


Figure 4. En route air traffic controller top-level goal hierarchy

Pilots tend to assess the benefit of a route deviation in aircraft-centered terms. They evaluate its potential to improve one or more of the five basic elements of the pilot's objective function: safety, legality, schedule, fuel efficiency, and ride quality (Endsley, *et al.*, 1998). Against these advantages they weigh the time and effort required of them to request and execute the deviation.

In contrast, controllers tend to assess the benefit of a route deviation in system-centered terms. They evaluate its potential to improve their own objective function, which takes into account any potential loss of separation, the effect of the deviation on the overall traffic flow (an indicator of future workload), and the time and effort required of them and other affected controllers to process the deviation (e.g., documentation, coordination, communication).

So although both pilots and controllers similarly weigh the advantages against the workload implications, their re-route assessments in fact have little in common.

Furthermore, the pilot's aircraft-centered decision process is isolated from the controller's system-centered decision process because neither agent has ready access to the information which the other considers relevant. For example, information regarding schedule, fuel efficiency and ride comfort—all of which are important to pilots—is not readily available to controllers, so they cannot easily incorporate such considerations into their decision process. Furthermore, neither pilots nor controllers have the means to know how much additional workload a particular request may create for their counterpart, and consequently it does not appear to factor into their decisions. In fact, the additional workload required for them to collect such data deters them from seeking it in the first place.

From this analysis it can be seen that the negotiation of route amendments between pilots and controllers is fraught with potential conflicts. With disparate goals, different cost bases, and limited information or feedback, it is not surprising that re-route negotiation is a common source of conflict between pilots and controllers.

The information upon which such negotiations are conducted varies, but pilots and controllers reported that traffic and weather information often provide the impetus to change path and typically impose constraints on the available alternatives. The importance of traffic and weather data is of interest, since at present pilots typically have information superiority with respect to weather while controllers typically have information superiority with respect to traffic.

These results are supported by the experimental observations of Midkiff & Hansman (1992) who found that pilots were more assertive towards ATC in weather situations and more compliant in traffic situations. In other words, pilots were more assertive when they knew they had an information advantage, and they were more compliant when they knew their information to be inferior. These observations attest to the power of information and illustrate how information can affect negotiation strategy.

To examine the extent to which information may affect pilot-controller interaction, a part-task simulator experiment was undertaken. Given pilots' and controllers' mutual interest in the flight path and the different criteria by which they evaluate flight plan deviations, the experiment was directed at re-routing situations. The importance of traffic and weather information as identified in the comparative analysis was reflected in the experiment's use of traffic and weather elements in the scenarios and the availability of a traffic and weather data link as the independent variable.

Chapter 3 Part-Task Simulator Study

Based on the findings of the situation awareness analysis, an exploratory experiment was conducted to investigate the extent to which shared traffic and weather information may lead pilots and air traffic controllers to cooperate or compete when negotiating route amendments. A part-task simulator experiment was designed to assess pilot and controller performance and behaviors in re-routing situations. Test scenarios focused on tactical routing decisions which would preclude the involvement of the Airline Operations Center (AOC). The availability of shared traffic and weather information (via digital data link) was manipulated as the independent variable in the experiment. Objective and subjective measures of situation awareness, negotiating posture, and overall performance were used in combination with experimenters' observations and subjects' comments to assess the overall system effect.

3.1 Objectives

The objective of the experiment was to explore the effects of shared information on pilot–controller interaction in re-routing situations. Of particular interest were the following:

- Does the availability of shared information between pilot and controller improve their situation awareness?
- Does the availability of shared information affect pilot and/or controller workload?
- Does the availability of shared information affect the amount of pilot–controller communication? More or fewer calls? Longer or shorter transactions?
- How does the availability of shared information affect the posture of pilots and controllers with regard to re-route negotiation? Do they become more cooperative? Do they become more competitive?
- What is the net effect of shared information on the quality of negotiated route amendments and overall traffic flow? What are the benefits? What are the concerns?

3.2 Approach

To explore these issues effectively, the study required a live, realistic and challenging environment in which for pilots and controllers to interact. A part-task simulator experiment was developed in which two subjects—one pilot and one controller—would interact to handle common en route tactical situations in real time. Scenarios were designed to provide enough structure to challenge the subjects, but also with enough latitude to allow the subjects to interact freely and develop their own options according to their goals and priorities. Scenarios were executed alternately with and without a digital data link for the sharing of traffic and weather information between the pilot and controller. Comparisons were made both within and between subjects.

3.3 Test Matrix

The experiment involved six pilot–controller subject pairs. Each subject pair completed one of two test matrices. As shown in Table 2, each test matrix contained six test scenarios: three scenarios performed with the data link disabled (i.e., no shared information) and three equivalent scenarios performed with the data link active (i.e., shared traffic and weather information). The only difference between the two test matrices was the status of the data link. In order to fully counterbalance the experiment, each successive subject pair performed the opposite test matrix. This facilitated between-subject comparisons.

Table 2. Test matrices

Test matrix for subjects 1, 3 & 5			Test matrix for subjects 2, 4 & 6		
Scenario Number	Data link Disabled	Data link Active	Scenario Number	Data link Disabled	Data link Active
1a	✓		1a		✓
2a	✓		2a		✓
3a	✓		3a		✓
1b		✓	1b	✓	
2b		✓	2b	✓	
3b		✓	3b	✓	

3.4 Independent Variable: Presence of Data Link

The independent variable for this experiment was the presence of a digital air–ground data link which transmitted continuously-updated traffic and weather information between ATC and the flight deck.

The data link was disabled in the baseline configuration. With the data link disabled, there was no sharing of information. Figures 5 and 6 illustrate how the weather and traffic information was allocated between the pilot and controller. Weather information was available only to the subject pilot via his cockpit map display; the subject air traffic controller received no weather information. Conversely, traffic information was available only to the subject controller via the plan view display; the subject pilot received no traffic information. Information was partitioned in this way to establish clear information superiority for one party relative to the other. Thus, in the baseline configuration, the pilot was in a superior position with respect to weather information but inferior with respect to traffic information. Conversely, the controller was in an inferior position with respect to weather information but superior with respect to traffic information.

In the "data link enabled" configuration, weather and traffic information were shared between the pilot and controller. Figures 7 and 8 illustrate how the weather and traffic information was allocated between the pilot and controller. The baseline weather information available to the pilot via the cockpit map display was supplemented with a prototype Cockpit Display of Traffic Information (CDTI), as shown in Figure 7. Similarly, the baseline traffic information available to the controller via the plan view display was supplemented with a prototype graphical weather overlay, as shown in Figure 8.

The CDTI was based on a prototype by Cashion, *et al.* (1997) and featured an integrated Traffic alert and Collision Avoidance System (TCAS) emulation. Aircraft within 100 n.m. and 2600 feet of the ownship were shown on the integrated map display. Two considerations were given in the design of the CDTI prototype symbology. First, an effort was made to provide the pilot with traffic information elements on the CDTI that were equivalent to those available to the controller via the aircraft data blocks displayed on the PVD. As shown in Figure 9, information elements included ground track, call sign, altitude, ground speed, and climb/descent indication

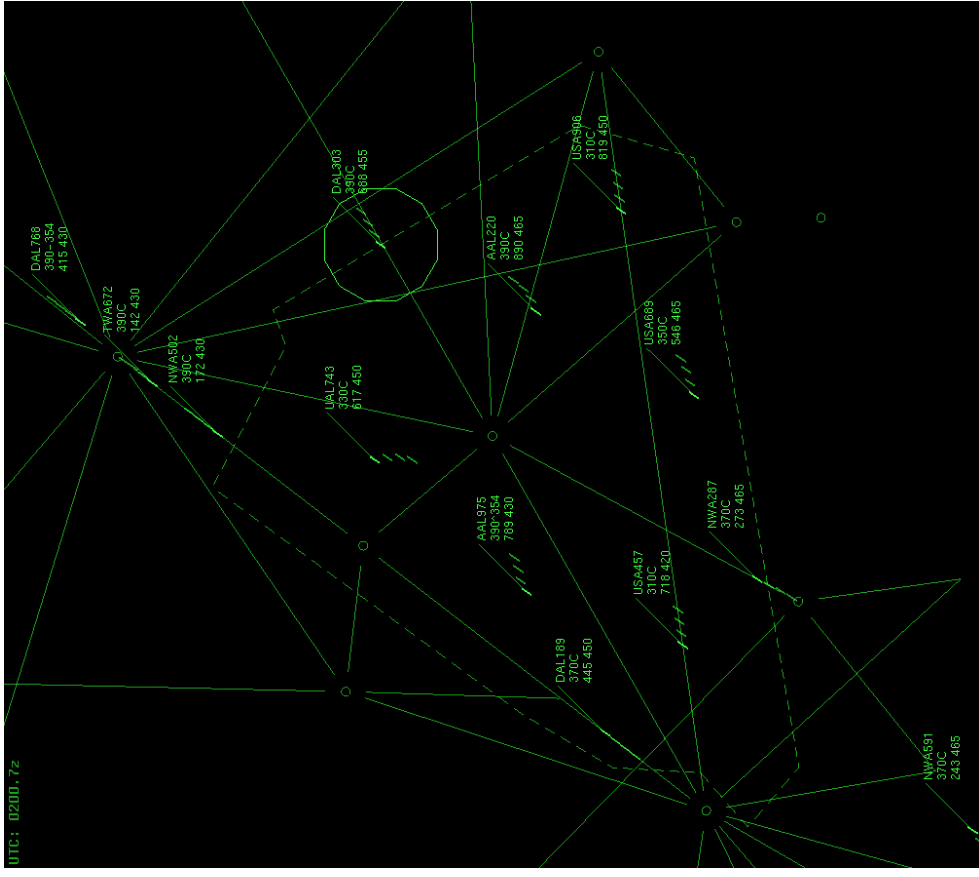
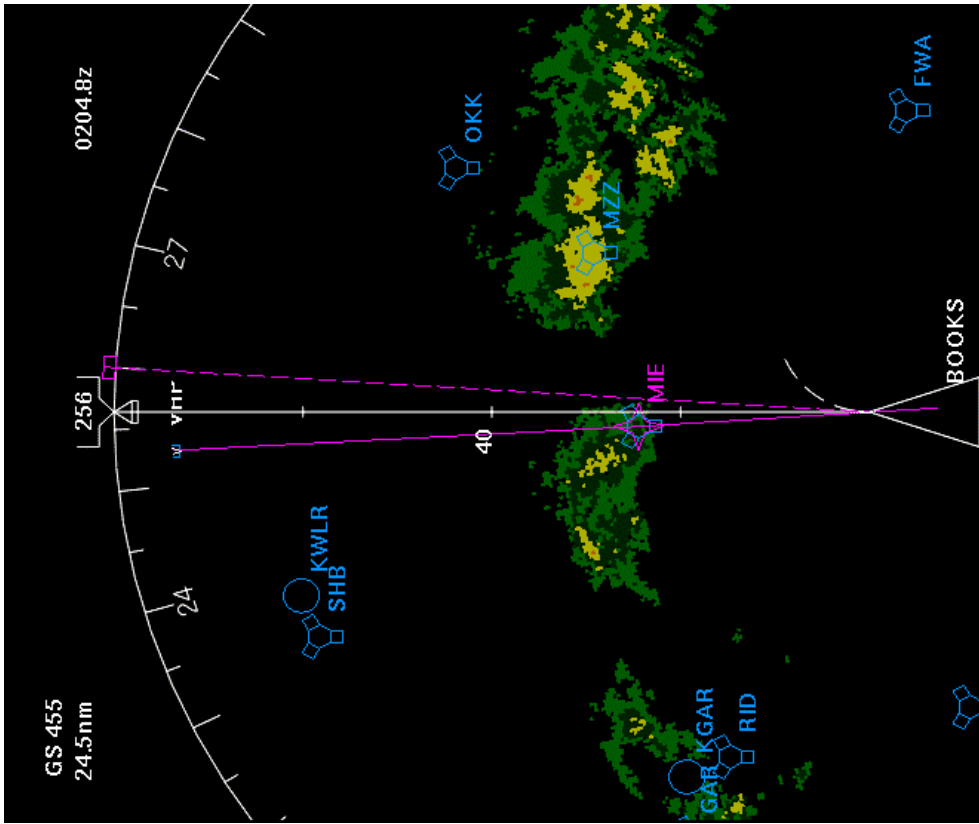


Figure 5. Pilot's display in baseline configuration. Note that no traffic information is presented.

(not shown). The computer identification number in the PVD data block was not incorporated as it offers no information of relevance to the pilot. Second, an effort was made to present the traffic information in the most useful reference frame for the pilot. Since TCAS systems typically present information in an aircraft-relative reference frame, relative altitude and relative ground speed were adopted for the CDTI symbology. An inverted "V" symbol indicated the ground track of each aircraft relative to the ownship. A data block beside the aircraft symbol denoted the aircraft call sign and relative ground speed² in knots. Relative altitude was indicated above or below the aircraft (as applicable) in hundreds of feet. The CDTI also incorporated TCAS II alerting logic, including traffic advisories and resolution advisories.

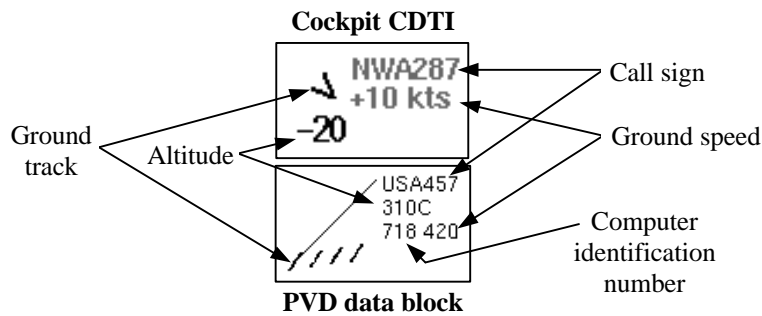


Figure 9. Cockpit and PVD traffic symbology

The pilot's and controller's weather displays provided identical precipitation reflectivity imagery based on NEXRAD ground-based weather radar data. The displays were capable of depicting seven distinct intensity levels of convective activity in shades of green (light intensity, -8 to 0 DBZ), amber (moderate intensity, 0 to +8 DBZ), and red (high intensity, greater than +8 DBZ). Since the radar source was ground-based, the weather display had effectively unlimited range and did not suffer from typical airborne radar anomalies such as attenuation effects. There was no "tilt" control available to the pilot.

² Relative ground speed was computed as the difference in magnitude between the ground speed of the intruder and the ownship; a positive value indicated that the intruder's ground speed exceeded that of the ownship.

3.5 Test Scenarios

Test scenarios were designed to probe pilot–controller situation awareness and behaviors in re-routing situations. Three basic scenarios were created, each representing common en route air traffic situations involving convective weather and moderate- to high-density traffic flows. The traffic and weather elements were scripted such that each scenario presented the test subjects with two fundamental tasks: a recognition task and a negotiation task.

The recognition task consisted of two situation awareness probes applied in parallel: one weather-related and one traffic-related. Both employed the “testable response” method (Pritchett & Hansman, 1996; see also Section 3.6.4). Under this performance-based methodology, potentially-hazardous traffic and weather conditions (one of each) were scripted into each scenario. The hazards were significant enough that a test subject who was aware of the hazard(s) would be compelled to respond. Thus, a subject's action or inaction in response to each hazard would provide a binary indication of his/her awareness of it.

The second fundamental task in each scenario was the negotiation task. If the subject controller and/or subject pilot recognized one or both of the testable response conflicts, their next task was to negotiate an acceptable route amendment to avoid the hazard(s). The re-routing decisions were tactical in nature and therefore did not involve an AOC. The intent was not to create situations that were necessarily difficult for the pilot or controller to resolve. Rather, the intent was to design situations which would play on the competing goals of the pilot and controller to offer each subject a fairly obvious—yet different—solution, thereby raising the need for re-route negotiation.

3.5.1 Airspace Sector

Test scenarios were set in Indianapolis Center airspace (ZID) in a high-altitude en route sector centered at Muncie, Indiana (MIE) (see Figure 10). Sector airspace spanned approximately 70 n.m. east-west and 85 n.m. north-south at its widest points, and it included altitudes 14,000 feet and above. Neighboring sectors were not depicted for the controllers. In situations requiring coordination with a neighboring sector, the subject controller was instructed to coordinate with the experiment monitor (a confederate) at their side who would accept or reject requests as they were made.

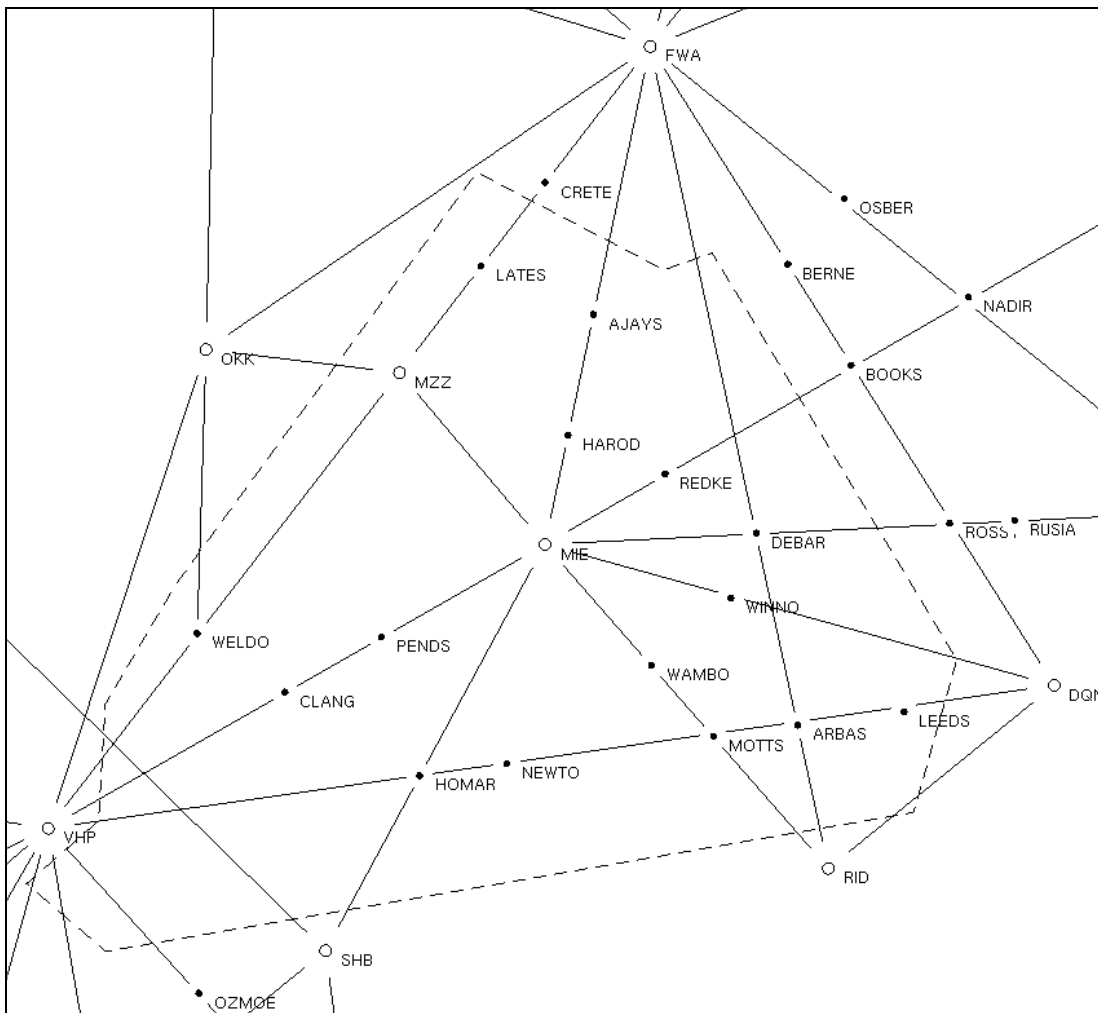


Figure 10. Indianapolis Center (ZID) high-altitude sector airspace features

3.5.2 Traffic Flow

Traffic flow through the assigned sector was fairly uniform. The traffic mix was approximately 15% widebody aircraft, 80% narrowbody aircraft, and 5% regional/commuter aircraft. All aircraft transitioned the sector in the cruise phase of flight; the subject controller was not faced with any departures or arrivals. Aircraft generally adhered to the published airways, except where deviations or direct clearances were approved by ATC. The subject controller was provided with a flight strip for each aircraft filed to transition his/her sector. The flight strip showed the aircraft's identifying information, expected time of arrival at the posting fix, and filed route of flight through the sector (see Figure 11).

UAL751 T/A320/E T430 11 11 243 01	05 02	350	LFD FWA MZZ VHP MAS	3147
	FWA	SEC11		
CALL SIGN EQUIPMENT FILED TAS SECTOR # CID STRIP #	MIN HRS EST. UTC AT FIX	CRUISE ALT	FILED ROUTE OF FLIGHT	XPDR CODE
	FIX	SECTOR ID		

Figure 11. Example en route flight progress strip (with template)

Traffic densities were high by design in order to make the scenarios challenging, given the homogeneity of the aircraft and their routes (e.g., no departures or arrivals). The number of aircraft in this relatively small sector averaged about eight aircraft at any given time. Scenarios were designed to maintain a regular flow of traffic of between five and eleven aircraft. Controllers were given the liberty not to accept an arriving aircraft if the sector workload became too high.

Every scenario was designed to have at least one potential traffic conflict. Scripted traffic conflicts involved merging traffic only; there were no scripted "blunders" or "busted" clearances, although some inadvertent cases did occur. Merging aircraft maintained constant airspeed and heading. In some cases, a scripted lateral conflict was compounded by an overtaking situation and/or an aircraft climbing to co-altitude.

3.5.3 Weather Elements

Every scenario featured one or more weather element. These elements were restricted to convective weather patterns: cells and fronts. Winds, icing, and temperature profiles were not modeled. The weather elements were static; there was no dynamic buildup, dissipation or drift. This simplification was mitigated by the short duration of the scenarios (less than ten minutes each). Weather patterns were retrieved from a commercial archive of NEXRAD weather data recorded from various sites across the continental United States. The elements used in these scenarios ranged from local, low-level precipitation to broad, high-intensity frontal systems.

3.5.4 Scenario Design

Three basic scenario templates were created for this experiment. The first template featured relatively light traffic flow and localized weather. The second template featured high traffic flow and a front of moderate-level convective activity. The third template featured moderate traffic flow and high-intensity weather. The sections that follow provide detail into the features and philosophy of their design.

3.5.4.1 Use of Repeated Scenarios

In order to make within-subject comparisons, it was necessary to perform each scenario twice: once without shared information and once with. To reduce the chance that a subject would recognize a scenario on its repeated trial, each scenario was modified to produce a second scenario which, although superficially distinct, was substantively the same. For example, aircraft identifiers were changed (e.g., airline, call sign, transponder code) and routes of non-factor aircraft were revised. Routes of confederate aircraft were "mirrored" symmetrically about the Muncie fix (MIE) at the center of the sector. In this way, while their *absolute* trajectories were considerably different, their *relative* trajectories remained essentially the same. Where necessary, the altitudes of confederate aircraft were amended in keeping with altitude-for-direction conventions. In the following sections, the 'a' [and 'b'] version of each numbered scenario represents the scenario in its original [and modified] form.

This page intentionally left blank.

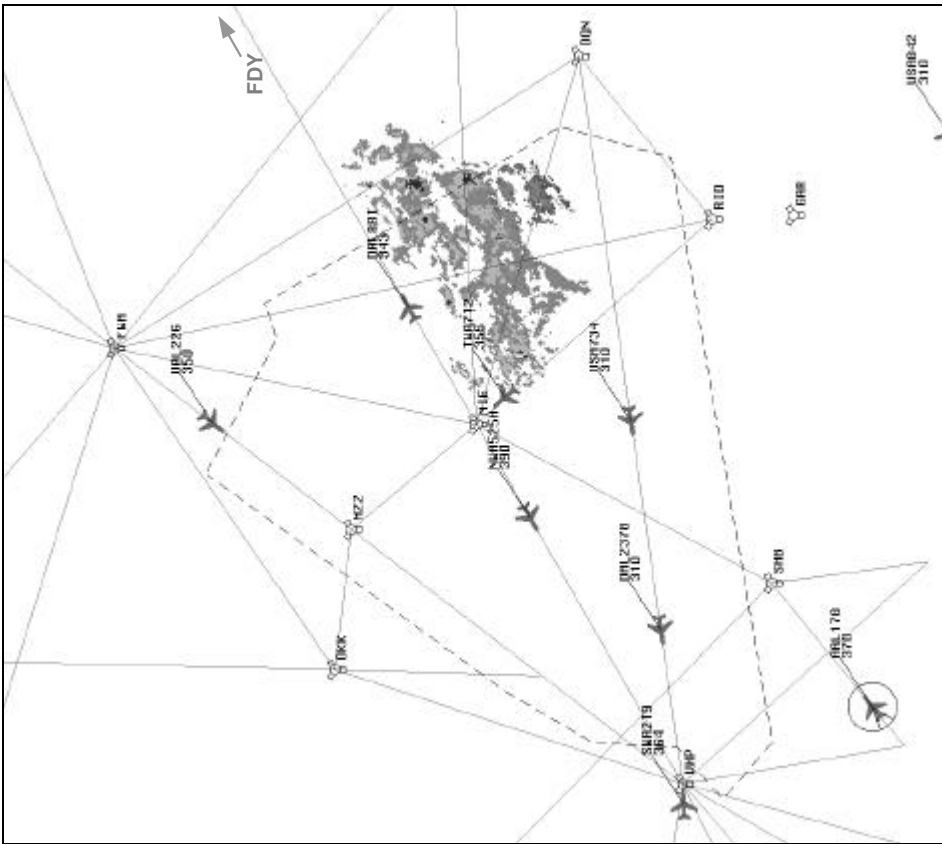


Figure 12. Scenario 1a—Subject aircraft (circled at lower left) on course to FDY via SHB and MIE.

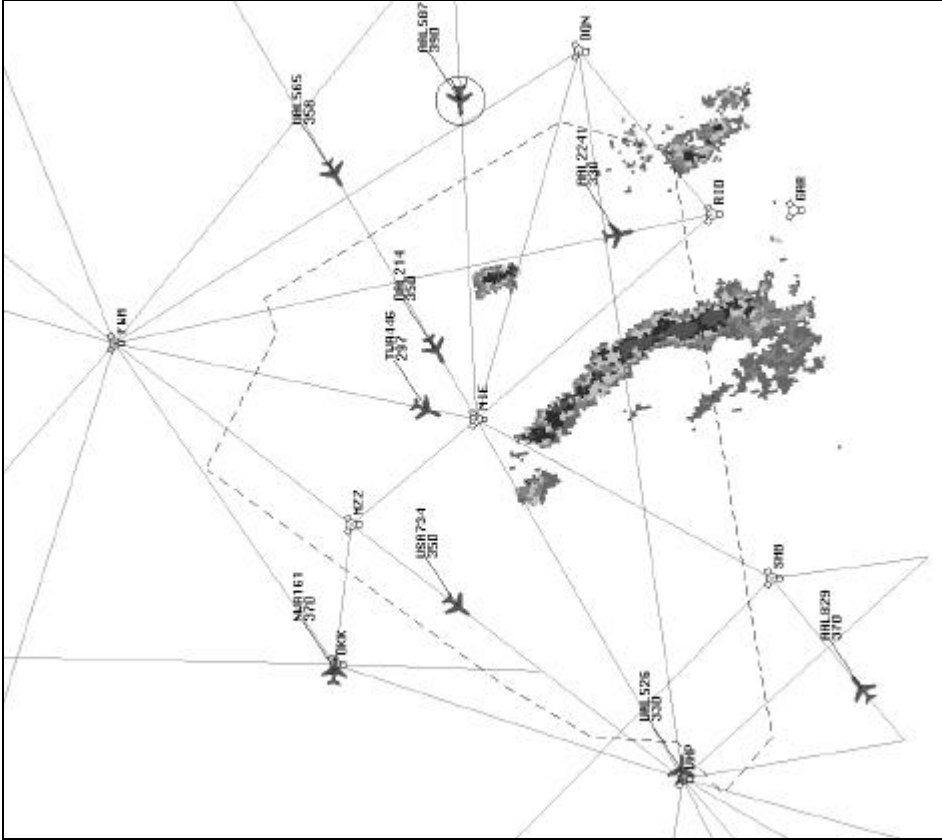


Figure 13. Scenario 1b—Subject aircraft (circled at right) on course to VHP via MIE.

3.5.4.2 Scenario 1

Scenarios 1a & 1b featured relatively light traffic and localized weather, as shown in Figures 12 & 13. The subject aircraft was initialized on a dog-leg course through the Muncie sector. A traffic conflict was scripted along the subject aircraft's present course. Weather obstructed the most likely deviation: the direct path short-cutting the dog leg.

The traffic conflict was designed such that, if no action were taken by pilot or controller, SWA219 [UAL565] would continue climbing to reach Muncie (MIE) co-altitude with—and less than a mile ahead of—the subject aircraft, resulting in a loss of lateral and vertical separation. The pilot of the confederate aircraft was instructed not to change trajectory unless commanded by ATC. Thus, it was incumbent on one subject or the other to initiate some action to avoid the conflict.

Disincentives were used to spoil the trivial solutions. For example, moderate turbulence was reported at flight level 330 [350] by the confederate pseudo-pilot of DAL881 [DAL214]. This would be a factor if the controller sought to solve the conflict by descending one aircraft. Similarly, the aircraft were performance limited to altitudes below 40,000 feet, a factor if the controller sought to solve the conflict by climbing one aircraft. Finally, the leading aircraft, SWA219 [UAL565], was 35 knots slower than the subject aircraft, which would be undesirable to the subject pilot if the controller were to sequence the subject aircraft behind the lead aircraft.

Without the shared information, the optimal solution from the controller's perspective was expected to be a clearance for the subject aircraft direct to FDY [VHP]. However, this would conflict with the pilot's goal of avoiding hazardous weather, thereby establishing grounds for re-route negotiation. The optimal solution from the pilot's perspective was expected to be the shortest route that would avoid the weather and would not require vectors for traffic.

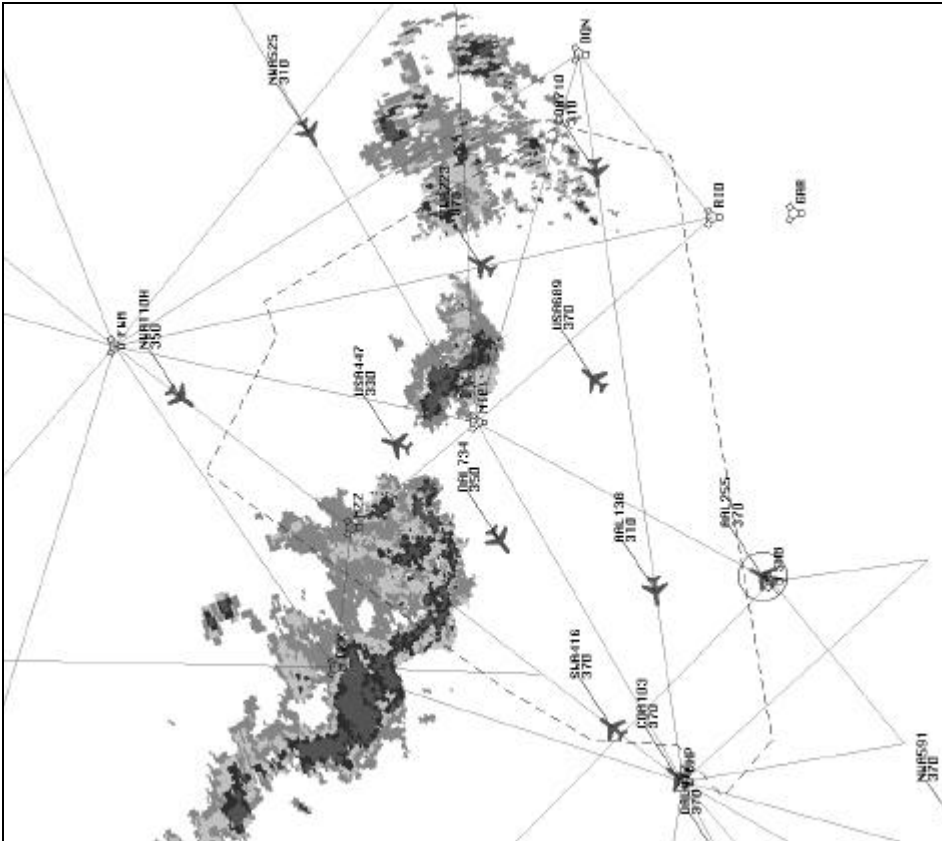


Figure 14. Scenario 2a–Subject aircraft (circled at bottom) on course to FWA via MIE.

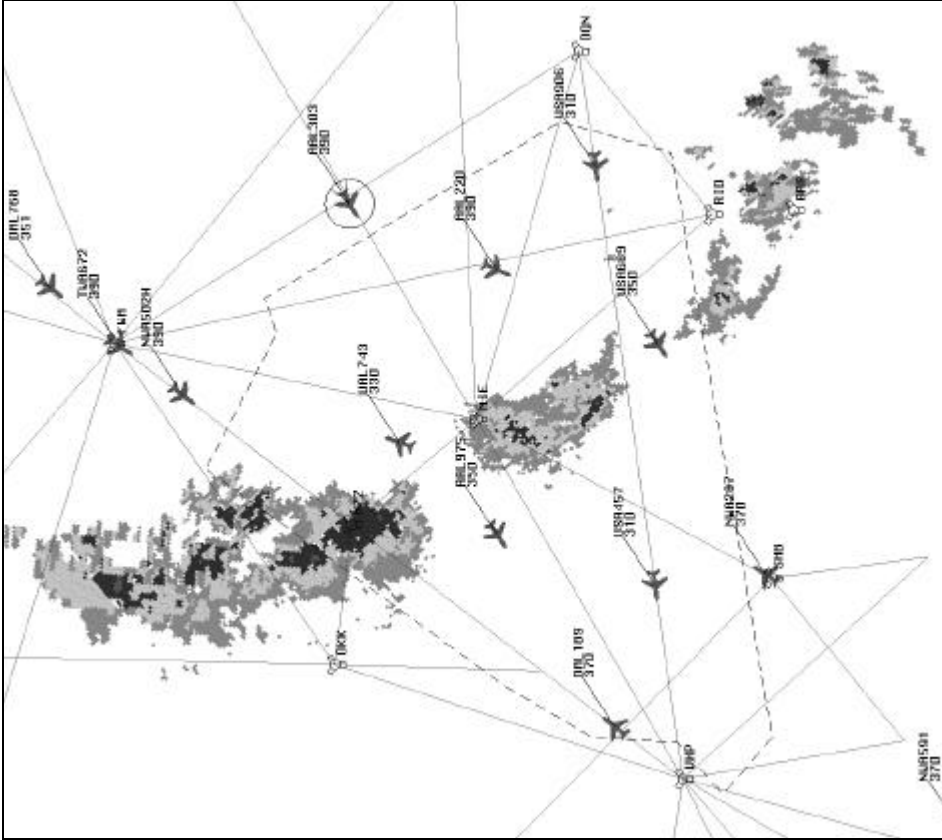


Figure 15. Scenario 2b–Subject aircraft (circled at right) on course to VHP via MIE.

3.5.4.3 Scenario 2

Scenarios 2a & 2b featured relatively heavy traffic and a moderate-intensity weather front with two discernable holes through which traffic was already diverting, as shown in Figures 14 & 15. The subject aircraft was bound for FWA [VHP] via MIE and was initialized on a course directly into weather at a point between the two holes. Conflicting traffic was scripted to occupy the more likely of the two deviations available to the subject pilot: the hole representing the shorter deviation for the subject aircraft.

The traffic flow was designed to favor the longer deviation. The two aircraft ahead of the subject aircraft had already opted for the longer deviation. Three aircraft merging from the west were scripted to compete with the subject aircraft for the more direct hole. As in scenario 1, disincentives were used to spoil the trivial solutions. Moderate turbulence was reported at flight level 330 [350] by the confederate pseudo-pilot of USA447 [AAL975].

The optimal solution from the controller's perspective was expected to be a clearance to follow in trail behind the two aircraft already deviating. The optimal solution from the pilot's perspective was expected to be a deviation through the more direct hole in the weather. Negotiation of an acceptable route amendment would then ensue.

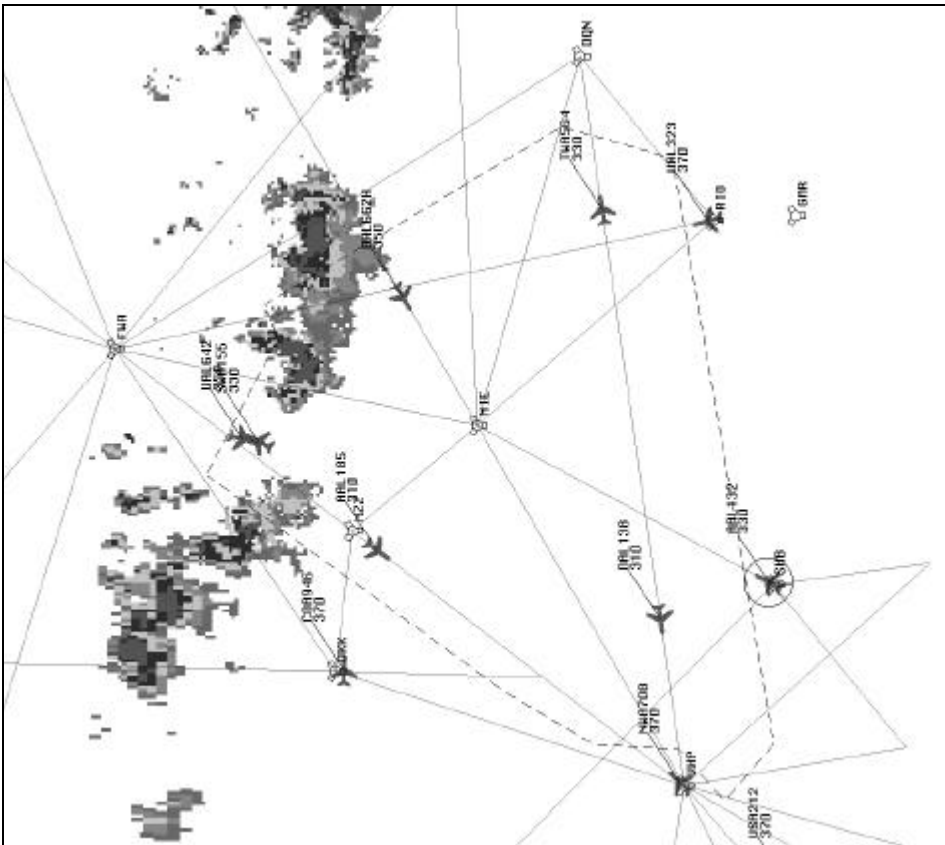


Figure 16. Scenario 3a–Subject aircraft (circled at bottom) on course to FWA via MIE.

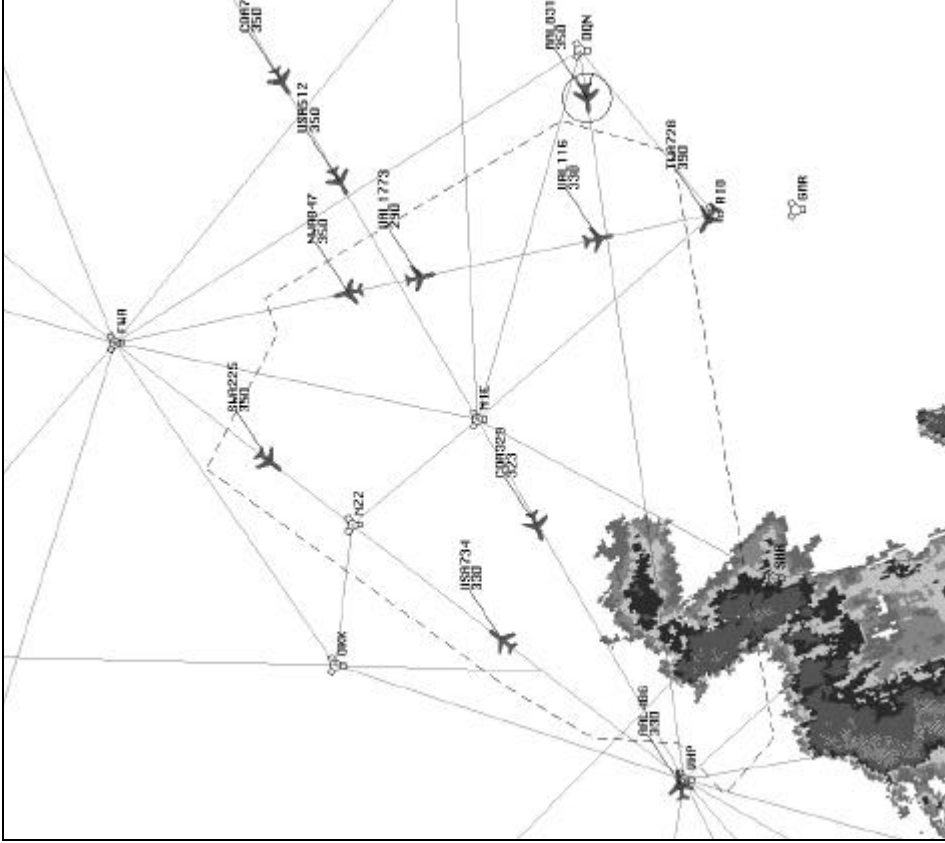


Figure 17. Scenario 3b–Subject aircraft (circled at right) on course to VHP via DQN.

3.5.4.4 Scenario 3

Scenarios 3a & 3b featured a moderate traffic flow and high-intensity weather obstructing one gate into and out of the sector, as shown in Figures 16 & 17. The subject aircraft was bound for FWA via MIE [VHP via DQN] and was initialized on a course directly into weather at a range of approximately 60 n.m. Conflicting traffic was scripted to compete for the shortest path around the weather.

The optimal solution from the controller's perspective was expected to be a clearance to remain at flight level 330 [descend to flight level 310], below the merging traffic at flight level 370 [350]. However, this solution would be scuttled by a report of moderate turbulence at flight level 330 [310] by the confederate pseudo-pilot of SWA155 [COA329]. The optimal solution from the pilot's perspective was expected to be a climb to flight level 370 [remain at flight level 350] and a sequence position ahead of the merging traffic, NWA708 [USA512]. Negotiation of an acceptable route amendment would then follow.

3.6 Protocol

3.6.1 Test Facility

The part-task simulator study was conducted in the Distributed Air Traffic Simulation Facility (Amonlirdviman, *et al.*, 1998) located at the MIT International Center for Air Transportation. This facility provided a virtual airspace environment capable of hosting multiple flight simulators, ATC simulators, and pseudo-aircraft simulators in a single, interactive, real-time simulation. For this experiment, the facility was configured with one advanced cockpit simulator, one ATC simulator, and one pseudo-aircraft simulator (see Figure 18). Live voice and data communication was provided between each simulator and the simulation host. In order to minimize non-radio interaction between the two subjects, the cockpit simulator and the ATC simulator were physically separated as shown in Figure 19.

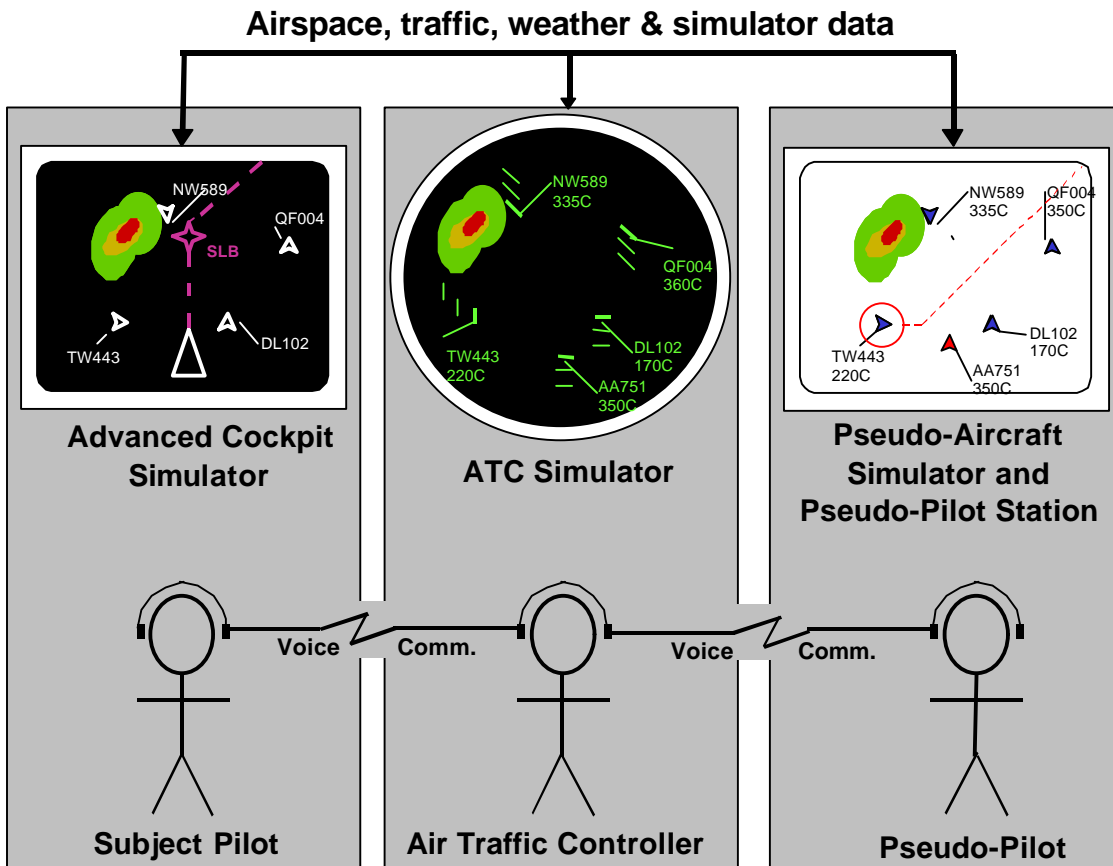


Figure 18. Distributed simulator facility configuration

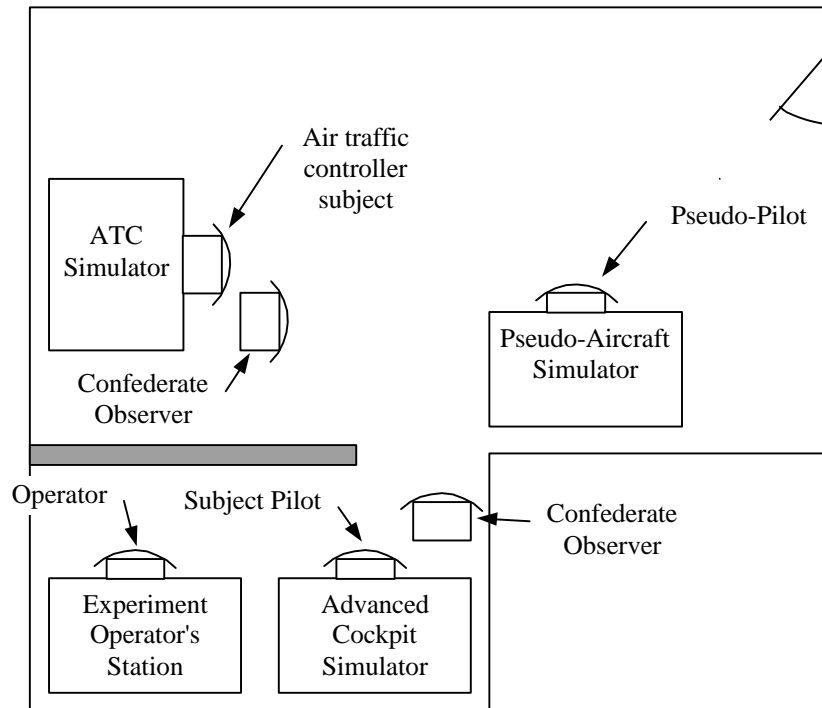


Figure 19. Distributed air traffic simulation facility

3.6.1.1 Advanced Cockpit Simulator (ACS)

The advanced cockpit simulator was a part-task flight simulator (see Figure 20). Cockpit hardware included an electronic display emulation, a Mode Control Panel (MCP), a side-stick controller, a Control and Display Unit (CDU), and a center pedestal housing the flap lever, speed brake lever, and throttle quadrant.

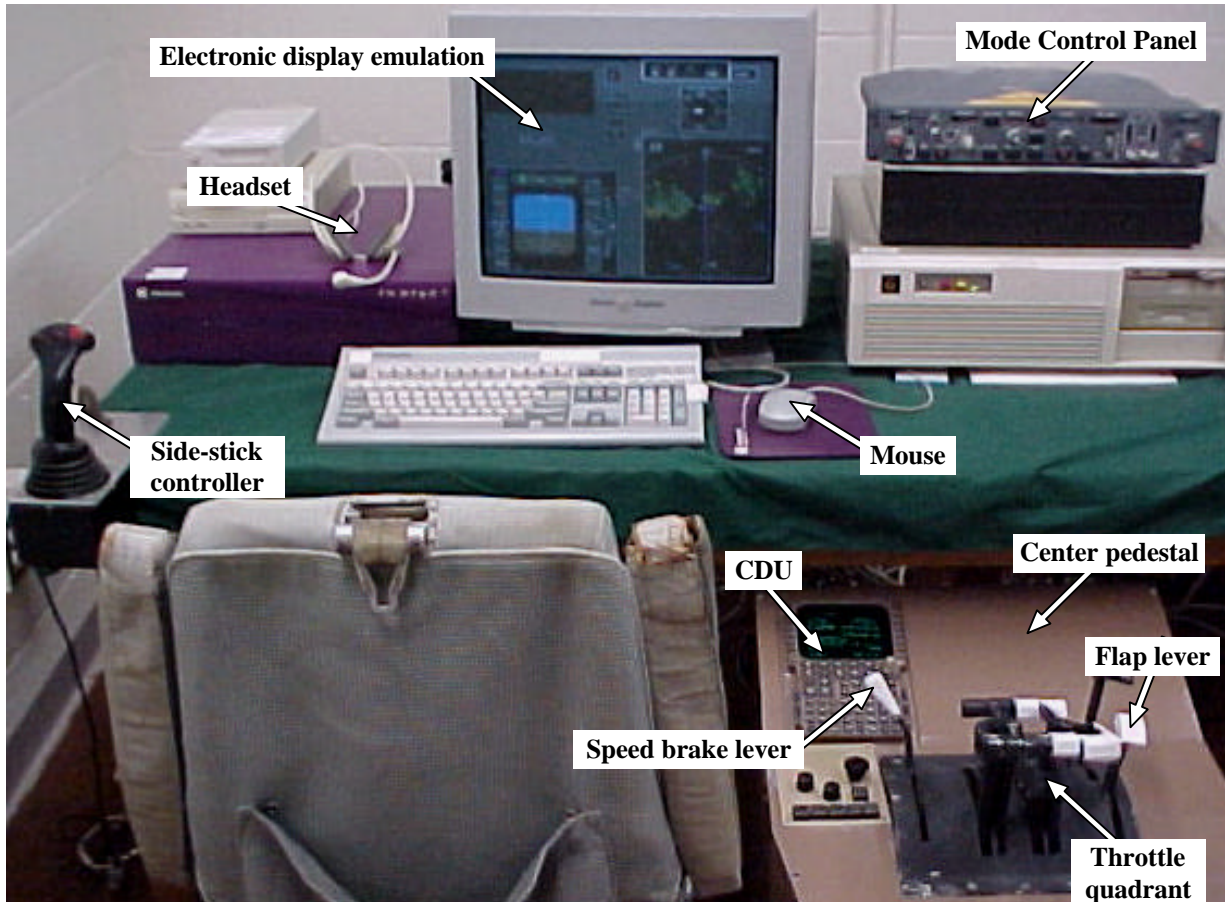


Figure 20. Advanced cockpit simulator

The primary components of the electronic displays were the Primary Flight Display (PFD) and the Electronic Horizontal Situation Indicator (EHSI). The PFD, as illustrated in Figure 21, emulated the PFD symbology and layout used in the Boeing 747-400 Electronic Flight Instrument System (EFIS). The EHSI was an integrated display prototype, with the capability to display route, weather, and traffic information, as shown in Figure 22.

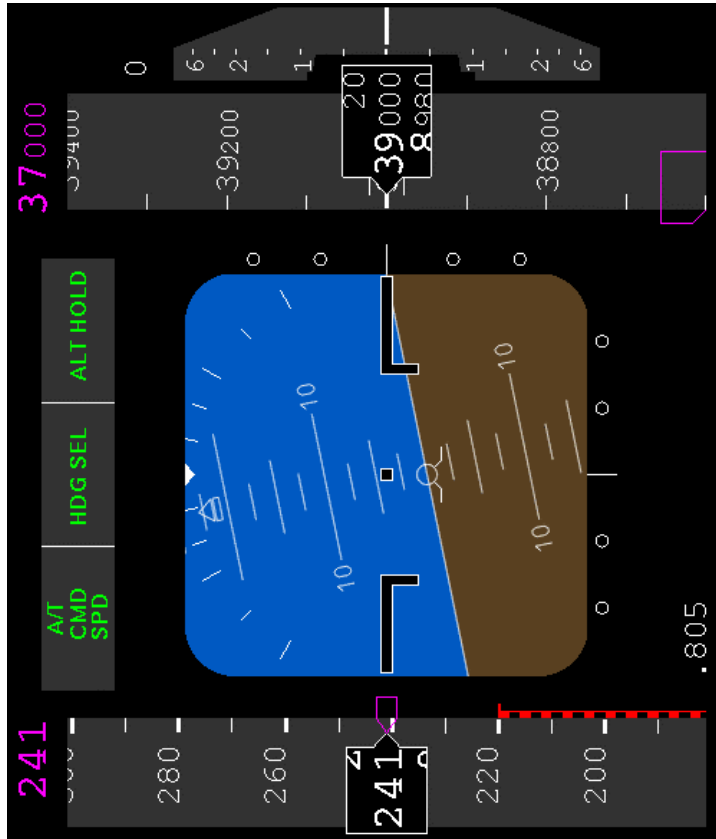


Figure 21. Primary Flight Display (PFD) for the Advanced Cockpit Simulator (ACS)

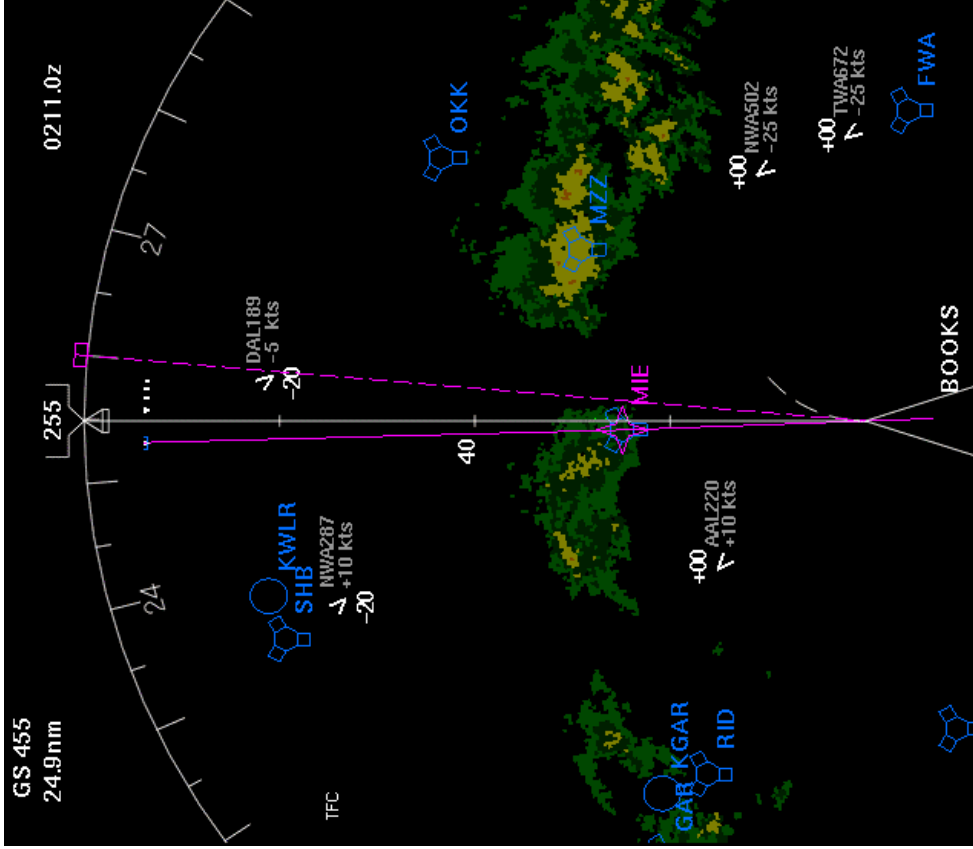


Figure 22. Electronic Horizontal Situation Indicator (EHSI) with prototype weather and traffic displays



Figure 23. ACS mode control panel

Subject pilots were free to operate their aircraft with whatever level of automation they deemed appropriate. Autopilot modes and target states were controlled via the mode control panel shown in Figure 23. The MCP was authentic 737-200 hardware and featured modes for heading hold, heading select, altitude hold, vertical speed, level change, lateral navigation (LNAV), and vertical navigation (VNAV). The aircraft trajectory in LNAV and VNAV modes was governed by a Flight Management System (FMS) emulation. The FMS enabled the pilot to input complex lateral and vertical flight plan segments into the autoflight system via the CDU. The CDU faceplate (see Figure 24) was actual Boeing 757/767 hardware. A side-stick controller was available for manual control if the subject pilot chose to disconnect the autopilot. Range of the map display could be increased or decreased by pushing buttons on the instrument panel using a mouse. Minimum range was five nautical miles; maximum range was not limited. The pilot was outfitted with a headset to communicate with ATC and other aircraft.



Figure 24. Control and Display Unit

3.6.1.2 Air Traffic Control Simulator

The air traffic control part-task simulator was modeled after the M1 consoles used at the 20 Air Route Traffic Control Centers (ARTCC) in the United States. The ATC simulator was comprised of the Plan View Display (PVD), Computer Readout Display (CRD), and Data Entry Control (DEC) system, and also included a map of the sector and

a set of flight strips for the aircraft currently in or approaching the sector (see Figure 25). The PVD displayed radar tracks and full data blocks for all tracked aircraft in the simulation within its assigned airspace sector, along with sector adaptation data such as airports, navigation aids, and airways. Although aircraft position updates were received continuously from the simulation host, target positions were updated only once every 12 seconds on the PVD to emulate the update rate of actual en route ATC equipment. Slewball inputs and/or alphanumeric keyboard commands were used to display supplementary information such as a target's current trajectory, filed flight plan, or position history. The same input devices were used to zoom or offset the plan view display. All data entry keyboard/mouse input sequences emulated those of the real DEC. In addition, the NEXRAD-based weather overlay prototype was integrated into the ATC display. Figure 26 shows the ATC simulator plan view display. The controller was outfitted with a headset to communicate with the aircraft transitioning the sector.

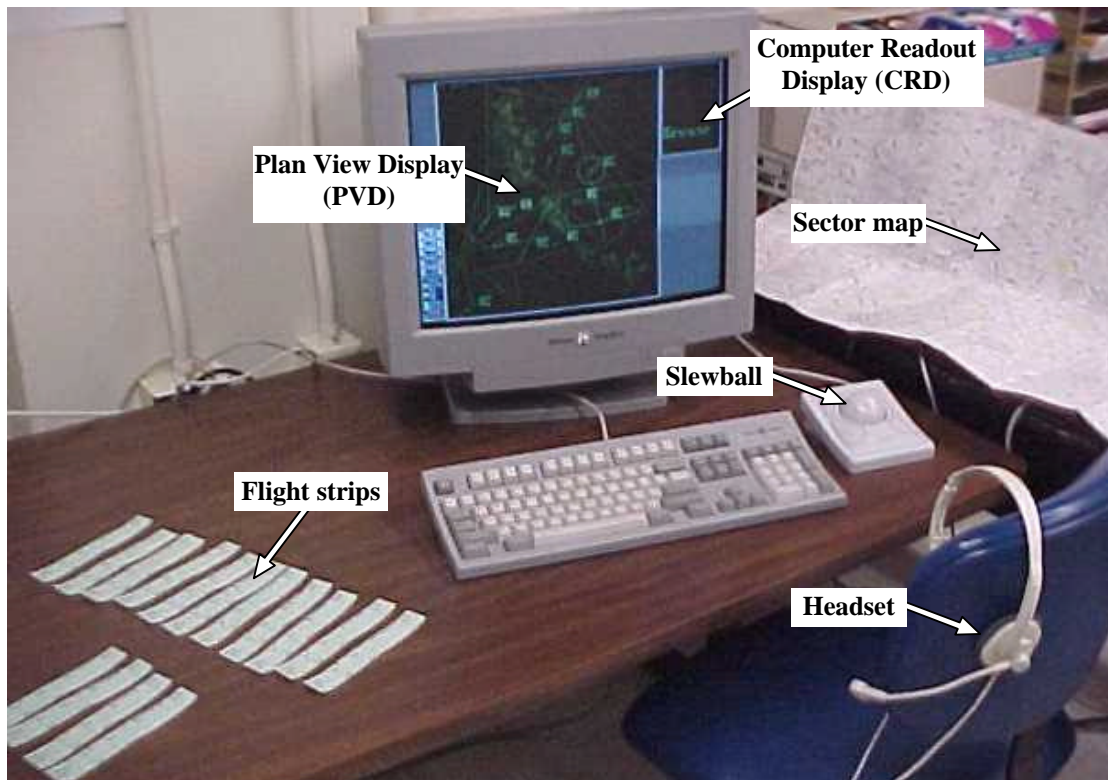


Figure 25. Air traffic controller's workstation

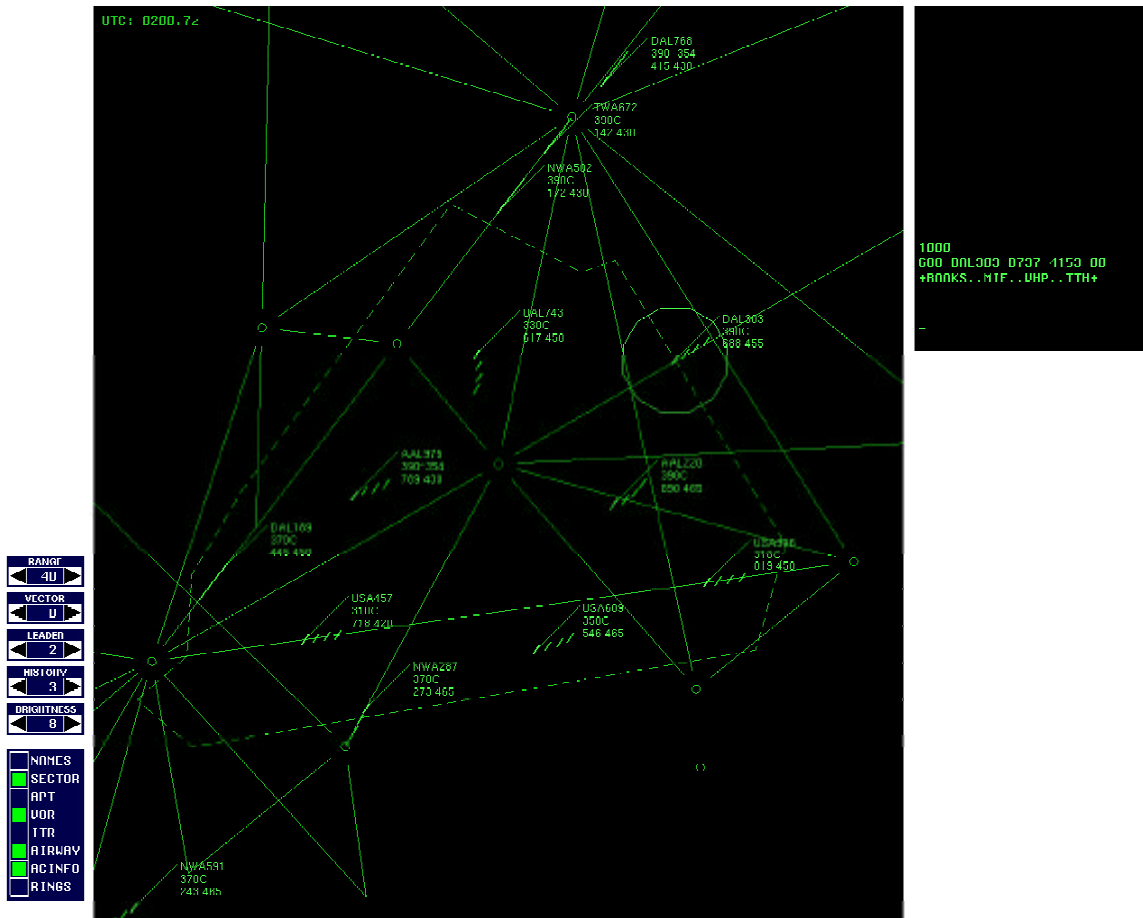


Figure 26. En route ATC Plan View Display (PVD)—Flight plan information displayed on the CRD and the 6-mile segmented circle (a.k.a. "J-ball") are for the subject aircraft being simulated by the ACS.

3.6.1.3 Pseudo-Aircraft Simulator and Control Station

All confederate air traffic (i.e., all aircraft not flown by the subject pilot) were simulated and piloted from the pseudo-aircraft simulator and control station shown in Figure 27. This SGI Octane-based application provided several key functions. For each pseudo-aircraft in the scenario, it simulated the aircraft dynamics and an on-board flight management function. In this way, each pseudo-aircraft could be preprogrammed with its own unique four-dimensional flight plan.



Figure 27. Pseudo-aircraft simulator and control station

The software also featured a graphical user interface to enable real-time control of pseudo-aircraft trajectories. Through an intuitive "point-and-click" interface, the pseudo-pilot was able to exercise outer-loop control of each aircraft's autoflight system. As shown in Figure 28, scenario feedback was provided to the pseudo-pilot via a large plan-view window depicting all of the air traffic in a region. When the pseudo-pilot selected a specific aircraft (by clicking on it with the mouse button), state feedback for the selected aircraft was provided via a "pseudo-cockpit" window (shown to the left of the plan-view window) which indicated the aircraft's current attitude, airspeed, altitude, heading, and flight control modes.

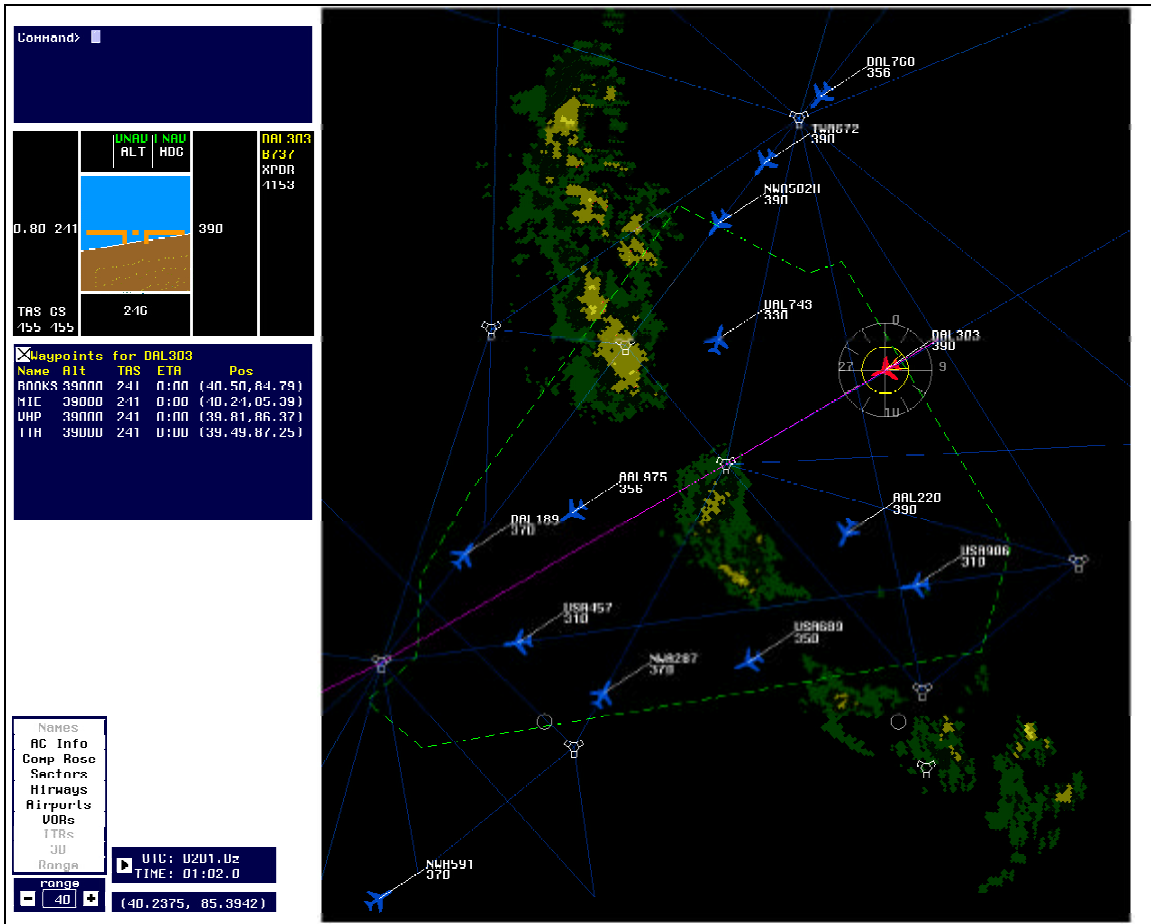


Figure 28. Pseudo-aircraft control display

The plan-view window and the pseudo-cockpit window also functioned as input devices for autoflight mode transitions and state commands. For example, the altitude tape served as a flight level change input. When the mouse pointer was positioned on the altitude tape, a command bug would appear. Moving the mouse pointer up the tape would increase the armed altitude; moving the mouse pointer down the tape would decrease the armed altitude. Clicking the second mouse button would activate the altitude command. The autoflight system would transition from VNAV to FLCH, and the selected aircraft would initiate a climb or descent accordingly. The pitch attitude indicator would go up or down accordingly, thereby providing immediate feedback that the desired input had been invoked. Analogous controls were implemented for speed and heading. Autoflight mode transitions could be manually enacted by clicking on the flight mode annunciator located above the attitude indicator.

3.6.1.4 Scenario Design Tool

Scenario designs were implemented with the use of the script development tools which were an integrated part of the pseudo-aircraft simulation and control station. The scenario design tools included some elements of a robust situation generation approach which enabled the user to build and store a unique flight plan of four-dimensional waypoints for each pseudo-aircraft in the scenario (Johnson, 1995). In playback mode, basic FMS-type navigation functions were implemented to control each pseudo-aircraft along its four-dimensional flight plan. This capability enabled the user to iteratively build and test air traffic scenarios off-line featuring many³ aircraft of various type, each having complex lateral, vertical and speed profiles. The scenario design tools use the same graphical user interface as the pseudo-aircraft simulator and control station, as shown in Figure 28. Performance constraints such as maximum speed, climb, and rate of descent were enforced to ensure reasonable pseudo-aircraft trajectories for the given aircraft type.

3.6.2 Subjects

Six air traffic control specialists and six commercial pilots were recruited to participate in this study. All participants were volunteers.

All six air traffic control specialists were Full Performance Level (FPL) controllers currently on staff at an Air Route Traffic Control Center (ARTCC). Radar experience ranged from 7 to 20 years, with a mean of 13.3 years. The controllers were between 31 and 48 years of age, with a mean of 38.0.

All six pilots were active jet aircraft pilots with an Air Transport Pilot (ATP) rating. Flight experience ranged from 6000 to 16,000 hours, with a mean of 10,117 hours. All had experience in “glass cockpit” and FMS-equipped airplanes. Pilots were between 40 and 53 years of age, with a mean of 45.2. Two of the pilots were corporate pilots and four were pilots with major airlines.

³ There is no inherent limit to the number of aircraft that can be scripted for a given scenario. While there are likely to be practical limitations due to computer memory and/or network bandwidth, simulations of 100 aircraft have been demonstrated with no adverse effects.

3.6.3 Procedure

The experimental procedure included three basic activities: preliminary briefings and training, formal testing, and final debriefing. Completion of the entire protocol typically required four hours.

3.6.3.1 Preliminary Briefings and Training

To begin, the pilot subject and the controller subject were briefed separately on the overall agenda for the session and their roles and responsibilities as subjects. Initial briefing materials are included in Appendix C.

Following the initial briefing, the subject pilot and controller were brought to their respective simulators where they were briefed on the airspace environment, operation of the simulator, special procedures, and their required tasks. There was no interaction between the two subjects during this training phase. The training checklists are included in Appendix D. During the pilot briefing, the features of the cockpit displays, flight control computers, and voice communication system were explained in detail. It was impressed upon them that their flight was straining to remain on schedule, that they were carrying revenue passengers, and that ride comfort was therefore a consideration. During the controller briefing, features of the Plan View Display, Data Entry Control (DEC) system, flight strips and voice communication system were covered. The controllers were reminded that current air traffic control procedures and standards were in force. Each subject was given time off-line to become familiar with the controls, displays, and simulation environment before engaging in any interactive, multi-agent simulation exercises.

Once both subjects were comfortable with the operation of their respective simulators, an interactive practice scenario was conducted to allow the subjects to operate their simulators and use the radio in a live, interactive, free-play scenario representative of the formal test environment. Practice scenarios were repeated until both subjects were confident in their ability to operate the equipment and comfortable with their assigned roles, responsibilities, and the simulation environment in general.

3.6.3.2 Formal Testing

Formal testing began immediately after training was concluded. Each formal test scenario began with the simulation "frozen". The subject pilot's aircraft was initialized in cruise trim and on course with the autoflight system engaged and tracking its preprogrammed route (LNAV). Both subjects were given a five-minute period in which to survey their static situation as shown on their respective simulator displays. Controllers were allowed to organize and annotate their flight strips to develop a "picture" of the traffic in and about their sector. Pilots were allowed to review their flight plan and the local weather as portrayed on their map display. The subjects were told in advance whether the air-ground data link would or would not be active for the queued scenario. This was intended to establish *a priori* an understanding of their relative information superiority (or inferiority) as a basis for any subsequent negotiation. No suggestions were given as to how they should make use of the available information or how to exploit any information advantage they might have. For cases in which the data link was disabled, controllers were notified of convective weather activity in the area, but the specific location and intensity of the weather was not specified. Similarly, pilots were notified of traffic in the area, but the specific location and altitude of the traffic was not specified. Except for the data link status (data link enabled or disabled), the simulator setup was identical for each experimental run.

Following the situation assessment period, the simulation was started. Each scenario began with a number of scripted radio calls from one or more of the confederate pseudo-aircraft. The subject pilot was instructed to check in with Indy Center at his first convenience as though he had just been handed off by the previous ATC sector. The subject pilot and subject controller were then free to take whatever action or contact whichever person they deemed necessary to accomplish their goals within the bounds of their assigned roles and responsibilities. Subjects were encouraged to verbalize (off the frequency) their thoughts, observations, and decision processes during the scenario as much as possible. An observer was assigned to each subject to record these comments and other noteworthy actions. Each scenario was allowed to run for approximately ten minutes, enough time for the subject aircraft to transition the airspace sector.

Following each scenario, each subject was administered a workload survey. In addition, following all scenarios in which the data link was disabled, controller subjects were asked to indicate on a sector map their best estimate of the location of the convective weather. These and other data collection activities are discussed in Section 3.6.4.

3.6.3.3 Debriefing

Upon completion of the six-scenario protocol, test subjects were interviewed individually and then jointly to elicit from them the advantages, disadvantages, and issues regarding the shared traffic and weather information. Subjective evaluations were solicited via a brief questionnaire.

3.6.4 Metrics and Data Analysis

The objective of this exploratory study was to identify changes in pilot-controller interaction with the availability of shared information. Five types of data were collected to help characterize and quantify changes in their interaction and overall performance:

- situation awareness data
- aircraft trajectory data
- voice data
- workload data
- subjective ratings.

Pilot and controller situation awareness was measured using the performance-based "testable response" method (Pritchett & Hansman, 1996). In each scenario, subjects were presented with one weather- and one traffic-related testable response condition (e.g., a storm cell, a converging aircraft). The conflicts were designed such that, if a subject had sufficient situation awareness, a deliberate action was required. A subject's action or inaction in response to the weather or traffic conflict provided a measurable indication of that subject's situation awareness with respect to the specific weather or traffic conflict, respectively. Cases in which one subject's response to a conflict prompted or precluded the other subject's response were not considered valid data points.

In the absence of reliable weather information, controllers use pilot reports (PIREPs), aircraft trajectories, pilot requests, and other clues to construct a mental picture of the areas affected by weather and to project how the traffic flow will be affected. To gain some insight into the accuracy of this heuristic, for scenarios in which a weather overlay was not provided, controllers were asked to draw on a sector map the location of any weather cells as inferred from the aircraft trajectories and information attained over the voice channel. Drawings were made at the conclusion of each scenario, and the controllers were allowed to refer to the PVD (frozen at the end of the scenario run) as necessary. The drawings were subsequently compared against the actual location of the weather to assess the degree to which they coincided.

Aircraft trajectory data were recorded for every aircraft in the simulation (i.e., the subject aircraft and all pseudo-aircraft). The trajectory data were recorded at a rate of approximately 10 Hz and included the parameters listed in Table 3.

Table 3. Recorded trajectory parameters

Aircraft call sign and type	Indicated airspeed	Commanded altitude
Transponder code	True airspeed	Commanded airspeed
Latitude	Ground speed	Commanded heading
Longitude	Vertical speed	Commanded vertical speed
Altitude	Pitch, roll, heading	Flight plan data
Radio altitude	Flight path angle	

Using these recorded data, it was possible to reconstruct and replay each scenario. The reconstructed flight paths were used to assess the strategies employed by each subject and to identify separation violations and other events.

Voice data were recorded and used to characterize the relative cooperativeness/competitiveness of pilot-controller interactions and to provide insight into changes in each subject's strategies. All voice transmissions between the subject pilot, the subject controller, and the pseudo-pilot were digitally recorded. The recordings were transcribed verbatim to written copy. For each transmission, the transcript identified the speaker and provided a time stamp. Using the methodology of Prinzo, Britton, & Hendrix (1995), each transmission was divided into discrete speech acts, and each speech act was coded by category and topic. An example of the speech act coding sheet is provided in

Appendix E. Speech acts were assigned to one of the thirteen speech act categories listed in Table 5, adapted from Foushee, Lauber, Baetge, & Acomb (1986) to accommodate pilot-controller communications. Each speech act was also identified with its applicable topic(s), if any. Eight speech act topics were defined, as listed in Table 4.

Table 4. Speech act topics

Route / Heading	Weather
Altitude	Traffic
Speed	Ride / Turbulence
Radio frequency	Other

The coded voice transcript data were tallied, and paired t-tests were applied to assess the significance of the differences between the means with and without the shared data link.

In addition to the "radio" voice data, the off-frequency comments of the pilots and controllers regarding their strategic considerations, options and tradeoffs were also recorded. These comments were reviewed for indications of strategic differences in their route planning when shared information was available, and for any shift in their attitude toward their counterpart and/or the negotiated re-routing.

Workload data were collected and analyzed in accordance with the NASA Task Load Index (NASA-TLX) methodology (Hart & Staveland, 1988). Following each test scenario, each subject completed a brief "workload rating" survey; at the end of all scenarios, each subject completed the "workload sources" survey. A sample of each survey is provided in Appendix F. Survey responses were used to compute a NASA-TLX composite workload score for each test scenario for each test subject. Paired t-tests were applied to assess the statistical significance of the data.

At the conclusion of the experiment, each subject was asked to provide a subjective rating as to the value of the shared traffic and weather information in performing their job functions. An example of the rating format is shown in Figure 29.

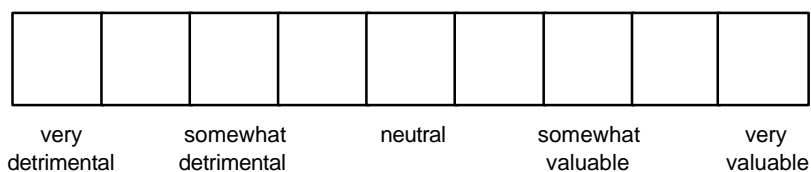


Figure 29. Subjective rating format

Table 5. Speech act categories (adapted from Foushee, *et al.* (1986))

Command	A specific assignment of responsibility by one group member to another.
Request	A request for another party to take an action, or a request for permission to take an action.
Acknowledgement	a) Makes known that a prior speech act was heard; b) Does not supply additional information; c) Does not evaluate a previous speech act.
Courtesy	Word(s) or phrase(s) spoken as an act of courtesy.
Advisory	Recognizing and/or noting a fact or occurrence relating to the task.
Suggestion	Recommendation for some specific course of action.
Inquiry	A request for factual information relating to the task. Not a request for action.
Answer	Speech act supplying information beyond mere agreement, disagreement, or acknowledgment.
Statement of intent	Announcement of an intended action by speaker. Includes statements referring to present and future actions, but not to previous actions.
Response uncertainty	Statement indicating uncertainty or lack of information with which to respond to a speech act.
Embarrassment	Any comment apologizing for an incorrect response, etc.
Repeat	Restatement of a previous speech act.
Non-codable	Speech act which is unintelligible or unclassifiable with respect to the present coding scheme.

Chapter 4 Results

This chapter presents the experimental results. First, the effect of shared information on pilot and controller situation awareness is assessed. This includes a discussion of controllers' ability to build good situation awareness regarding the effect of weather on traffic flows in the absence of graphical weather information. Section 4.2 investigates the separation violations that occurred over the course of the experiment to assess the relationship between shared information and performance. This is followed by the presentation of the communication analysis, addressing the effect of shared information on pilot–controller interactions. Lastly, the workload data is presented, and the pilots' and controllers' subjective ratings of the value of shared information are discussed.

4.1 Situation Awareness

Two approaches were taken to the situation awareness (SA) analysis. The first approach used the performance-based testable response methodology to assess the situation awareness of the subject pilot and subject controller with respect to weather and traffic in real time. The second approach to assessing situation awareness used a visual recall task at the conclusion of each scenario to focus on the situation awareness of the subject controllers with respect to weather only. The two methodologies are discussed in greater detail in Section 3.6.4. The two sets of results are presented below.

4.1.1 Testable Response Data

Each test scenario included one weather-related testable response condition and one traffic-related testable response condition. Both the pilot and controller were monitored for their awareness of each testable response condition.

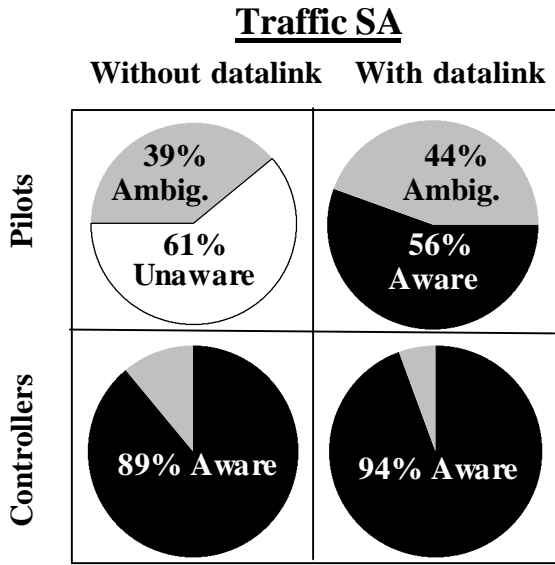


Figure 30. Pilot and controller awareness of traffic-related testable response conditions

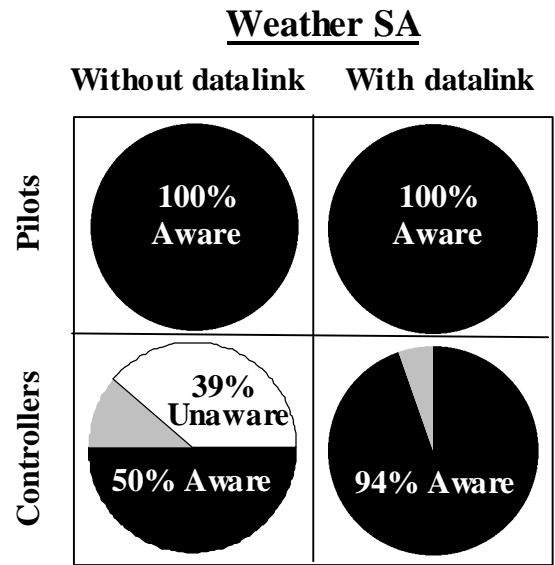


Figure 31. Pilot and controller awareness of weather-related testable response conditions

Figure 30 summarizes the results of the traffic-related testable response probes. Pilots, without the benefit of a traffic display in the baseline configuration, did not demonstrate awareness of any of the traffic-related testable response conditions. When provided a shared traffic display, pilots demonstrated awareness of 56% of the traffic-related testable response conditions. In many cases, the controller recognized the traffic conflict before it became a significant threat to the pilot and either advised the pilot of the traffic or vectored the pilot accordingly. In such cases, the pilot's opportunity to independently recognize and respond to the hazard was precluded, and the testable response result for the pilot therefore was labeled "ambiguous".

Controllers, having the benefit of their plan view traffic display for all test scenarios, demonstrated a high level of awareness of the traffic-related testable response conditions. In some cases, a deviation requested by the subject pilot resolved the traffic-related testable response condition before it arose; such cases were labeled "ambiguous" with respect to controller situation awareness.

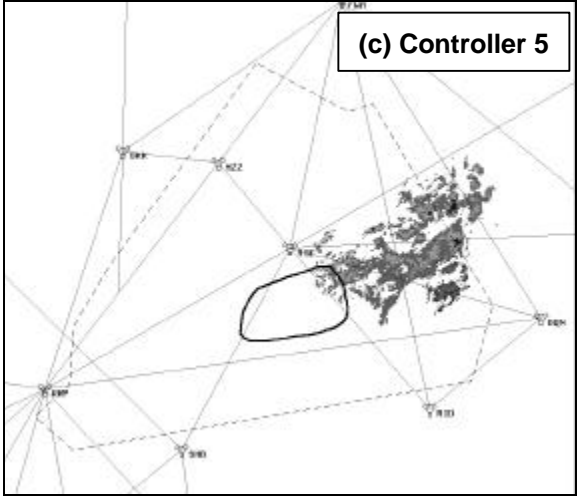
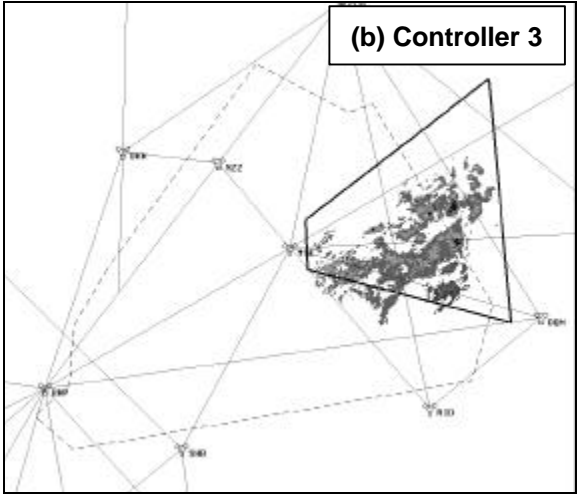
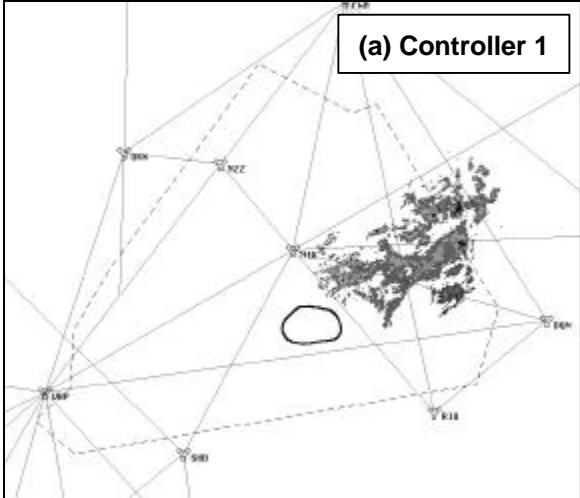
Figure 31 summarizes the results of the weather-related testable response probes. Pilots, having the benefit of the weather display for all test scenarios, demonstrated awareness of all of the weather-related testable response conditions. Controllers, without

the benefit of a weather display in the baseline configuration, demonstrated awareness of only 50% of the weather-related testable response conditions. When provided a shared weather display, controllers demonstrated awareness of 94% of the weather-related testable response conditions. In one case, a controller gave conflicting indications of his/her awareness of the weather conditions. For that case, the controller's testable response result was labeled "ambiguous".

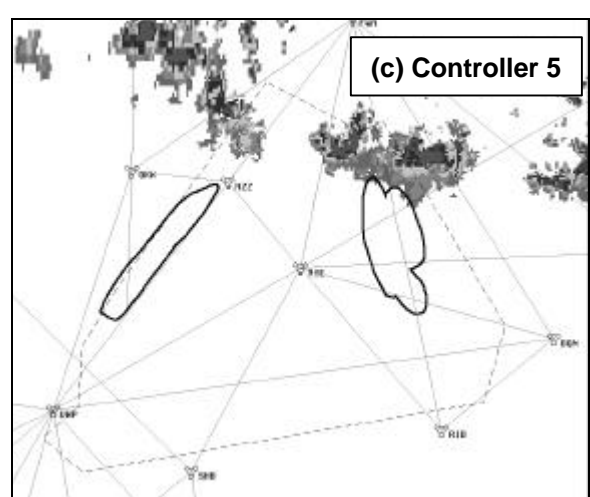
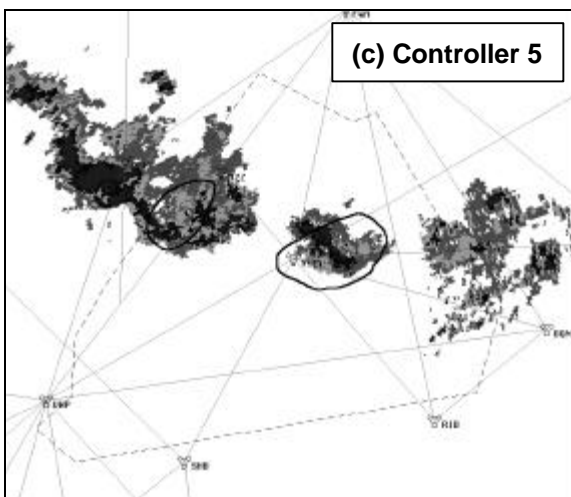
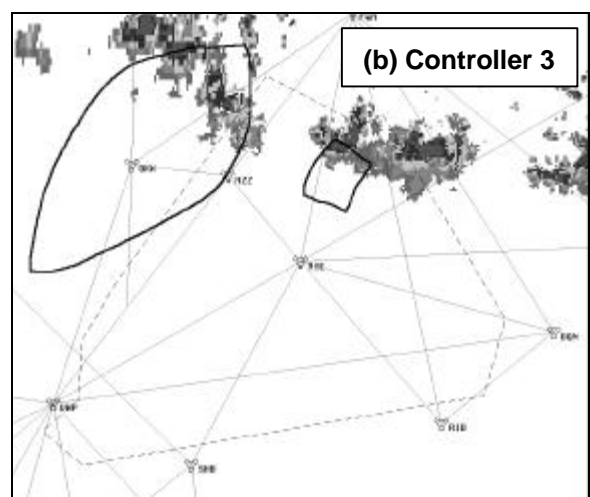
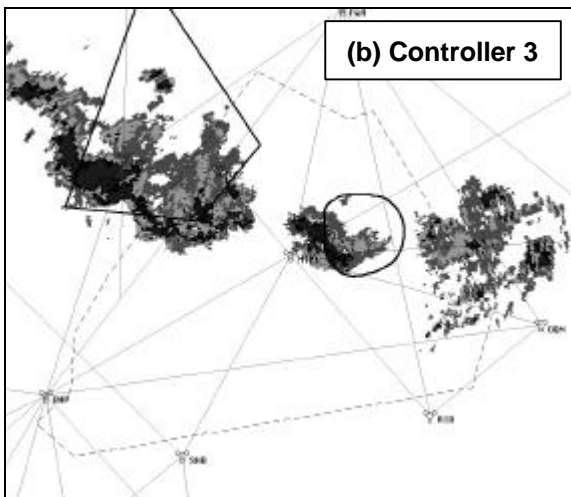
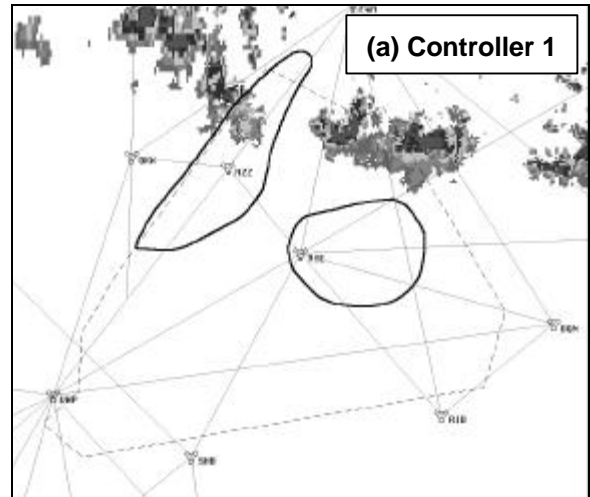
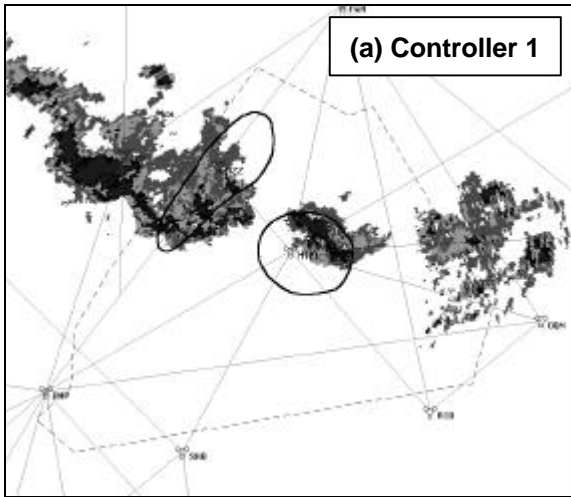
These results indicate that pilot situation awareness with respect to traffic improved with the addition of a CDTI. Similarly, the results suggest that controller situation awareness with respect to weather improved with the addition of a weather overlay to their plan view display. These results confirm that shared information via air-ground data link can improve situation awareness for both pilots and controllers.

4.1.2 Controllers' Weather Awareness Data

The benefit derived by the controllers from the prototype weather display is made clearer when one compares the NEXRAD image of the weather situation as provided by the data link against the mental image of the weather situation as constructed by each controller in the absence of the data link. The drawings in Figures 32 through 37 facilitate this comparison. They illustrate the degree to which each controller was able to build an accurate mental model of the weather situation for a given scenario. The actual location of the weather is overlaid for reference. The nine figures on pages 50–51 correspond to subjects 1, 3 and 5 and are arranged in a matrix as follows: each row is subject-specific, containing the three drawings performed by each subject; each column is scenario-specific, containing each subject's drawings for the three non-datalinked scenarios. By comparing rows and columns separately, one can assess whether the dominating factor in developing weather situation awareness is the skill level of the controller or the nature of the weather pattern and traffic flows. The nine figures on pages 52–53 are similarly arranged and correspond to the weather drawings of subjects 2, 4 and 6. (Recall from Table 2 that the non-datalinked test cases for subjects 1, 3 and 5 were scenarios 1a, 2a and 3a, while the non-datalinked test cases for subjects 2, 4 and 6 were scenarios 1b, 2b and 3b.)

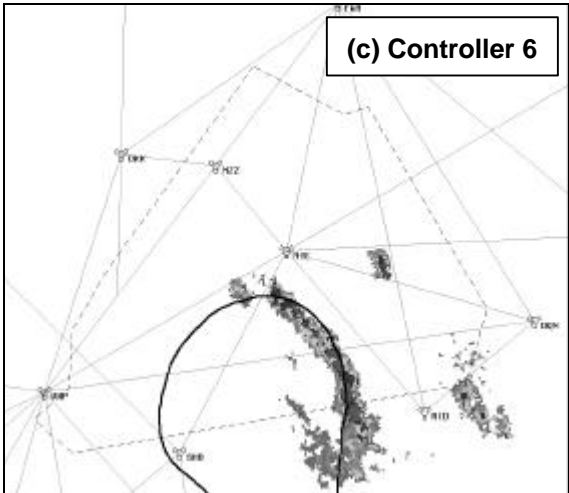
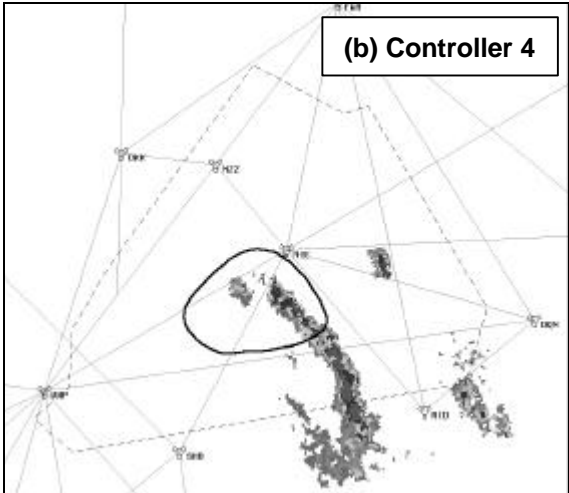
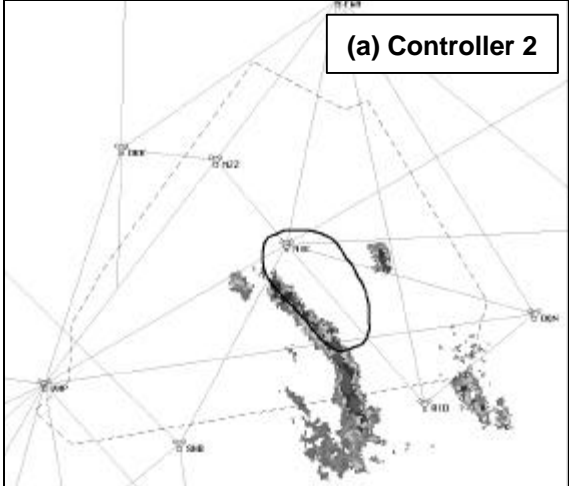


**Figure 32. ATC weather recall results
(Scenario 1a)**

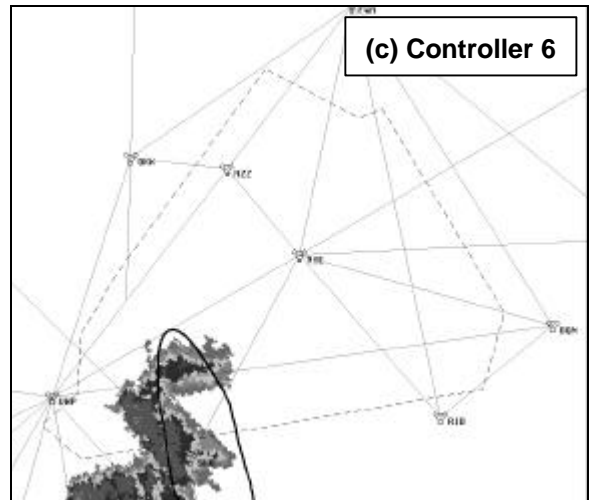
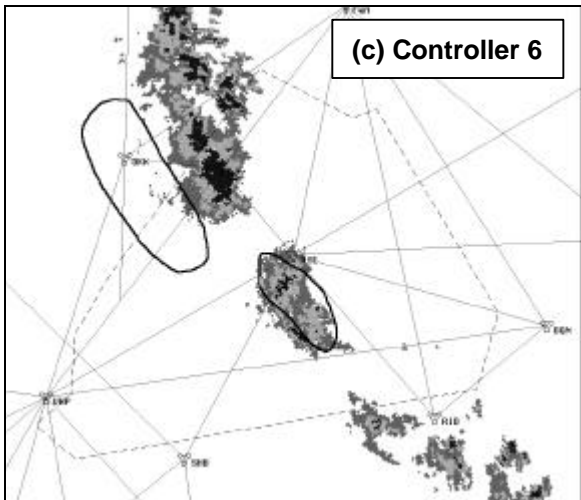
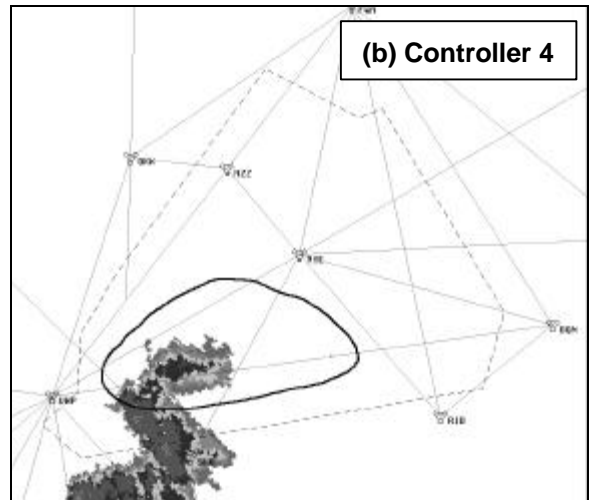
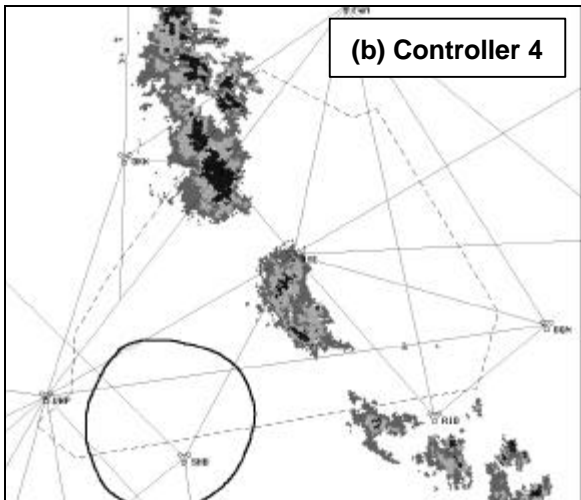
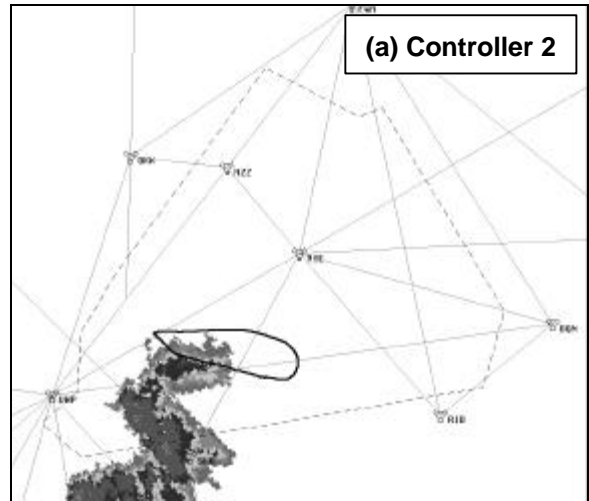
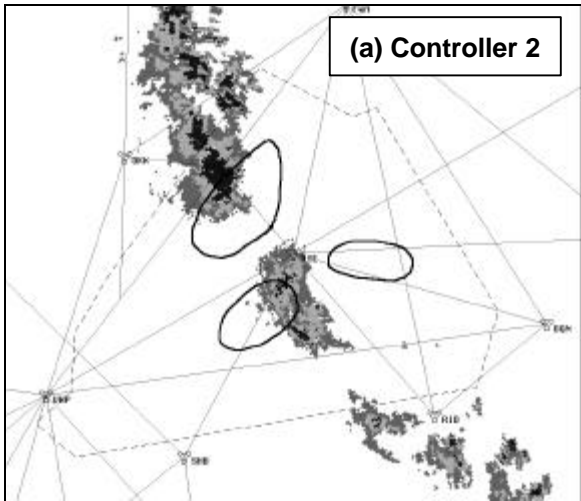


**Figure 33. ATC weather recall results
(Scenario 2a)**

**Figure 34. ATC weather recall results
(Scenario 3a)**



**Figure 35. ATC weather recall results
(Scenario 1b)**



**Figure 36. ATC weather recall results
(Scenario 2b)**

**Figure 37. ATC weather recall results
(Scenario 3b)**

A metric was developed to lend some quantitative insight into the controllers' performance on this exercise. The airways within the sector airspace were divided into 26 airway segments of between 15 and 20 n.m. each. For each scenario, the 26 airway segments were categorized as either "weather-obstructed" or "clear". For this simple metric, any airway segment that intersected the perimeter of a weather cell or lay completely within a weather cell was considered to be "weather-obstructed". The intensity of the cell (i.e., the color of the NEXRAD image) was not considered. All segments that were not "weather-obstructed" were considered to be "clear". Recall that the weather image was static, so it was not possible for an airway segment to change from weather-obstructed to clear, or vice versa.

Having categorized the actual coverage of the weather in terms of airway segments, the same procedure was applied to the controller sketches presented in the figures above (without the weather overlay). Airway segments that intersected a region drawn by the controller were recorded as "weather-obstructed". The remaining airway segments were recorded as "clear".

Figure 38 compares the controllers' inferred understanding of which airways were weather-impacted against the actual list of weather-impacted airways. The dark-colored portions of the pie graph represent the number of airway segments which were obstructed by weather. Of those airway segments, the controller subjects correctly identified fewer than half. Conversely, the light-colored portions of the pie graph represent the number of airway segments that did not intercept weather. Of those 333 airway segments, the controller subjects mistakenly identified 46 of them (14%) as being impacted by weather.

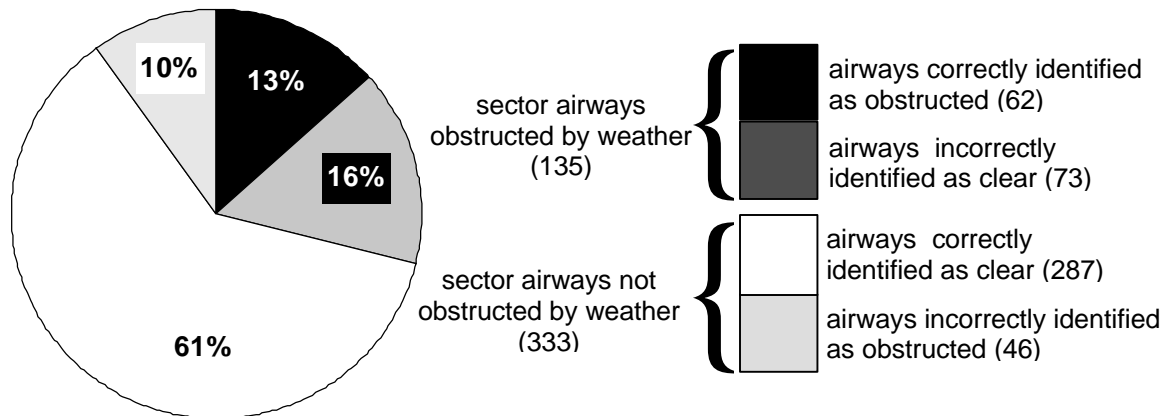


Figure 38. Cumulative weather inference results

In order to understand how these misperceptions develop, consider the figures on pages 56 through 59. These figures are identical to those presented on pages 50 through 53, except that the trajectories of all of the aircraft in the sector during the scenario have been overlaid. Note that, to first order, the trajectories tend to wind around the regions drawn by the controllers. This is consistent with the strategy controllers report using to deal with weather disturbances. In the absence of displayed weather, controllers attempt to identify and bound the weather-impacted areas in their sector, and they mentally set those boundaries based on the trajectories of the aircraft they control as best they can recall them. As a memory aid, some controllers use grease pencils to literally draw these bounded weather regions on the PVD screen, revising the boundaries where necessary as dictated by the most recent aircraft trajectories and pilot reports.

Examining the trajectory data, note that the regions drawn by the controllers closely reflect the curved trajectories of aircraft who negotiated course deviations with ATC. Note, too, that there are several cases in which a controller drew a weather region over an area which had clearly been traversed by one or more aircraft. (Figures 41 (a) and (c) contain prime examples.) The most flagrant cases involve aircraft which made no course deviations and, in general, did not have radio contact with the controller other than on their arrival to and departure from the sector. This suggests that during periods of high workload the trajectories of non-routine, deviating aircraft may figure more prominently in the minds of controllers as they attempt to build and maintain a mental picture of the weather situation.

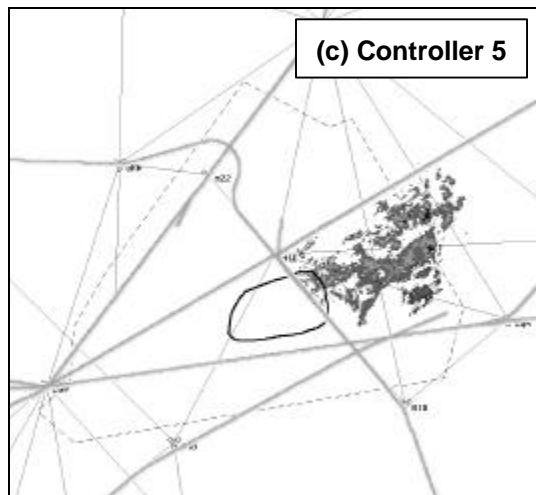
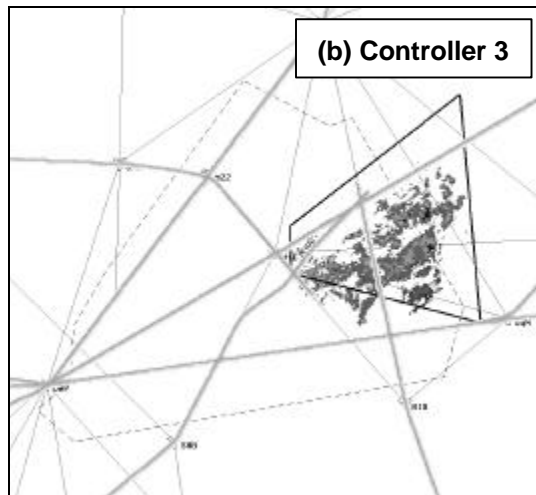
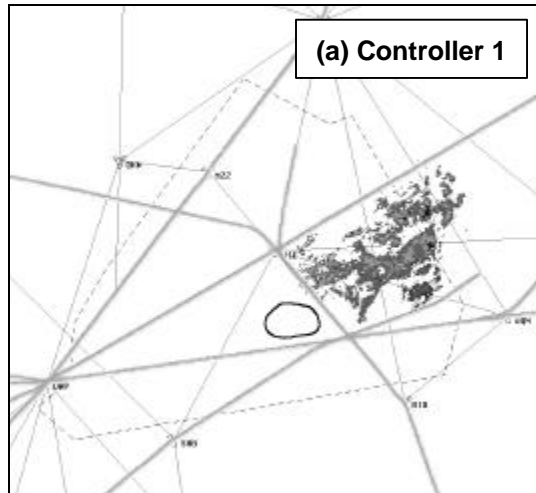


Figure 39. ATC weather recall results with tracks overlaid (Scenario 1a)

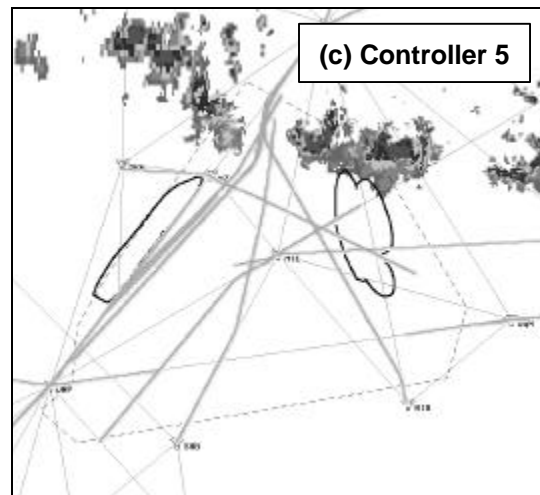
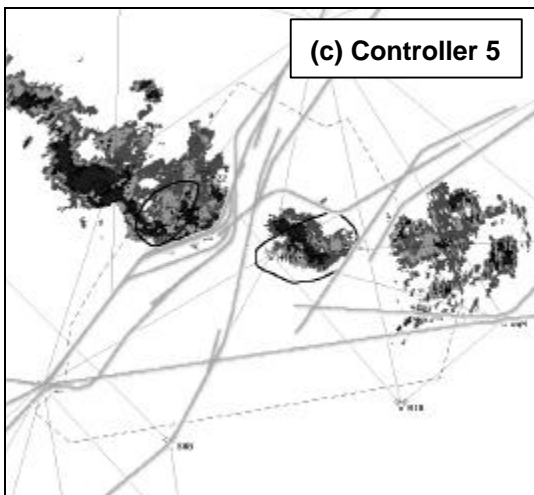
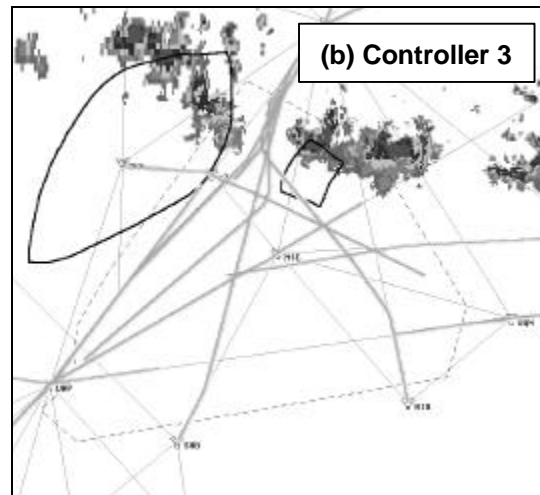
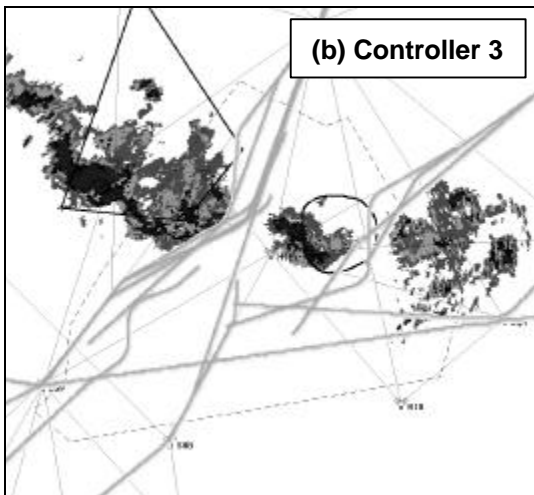
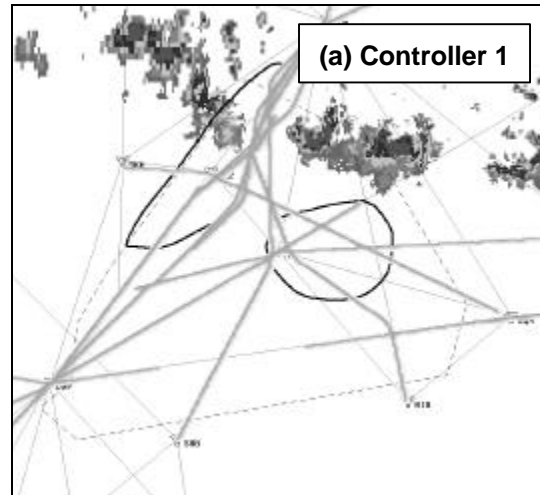
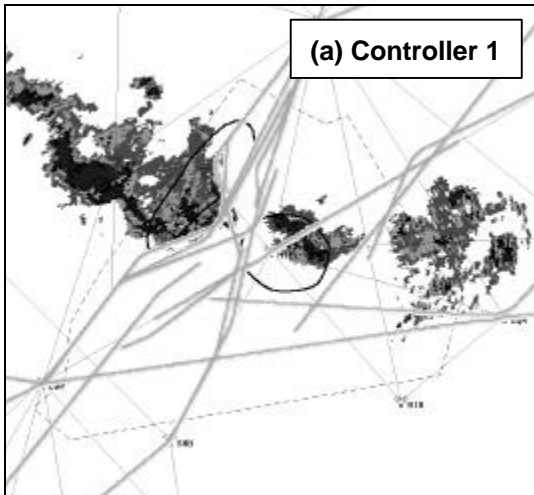


Figure 40. ATC weather recall results with tracks overlaid (Scenario 2a)

Figure 41. ATC weather recall results with tracks overlaid (Scenario 3a)

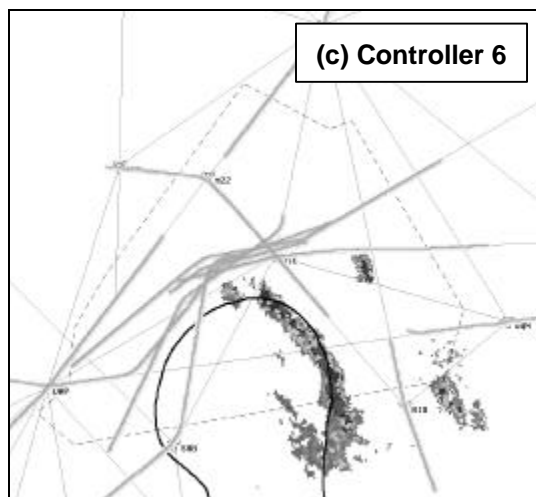
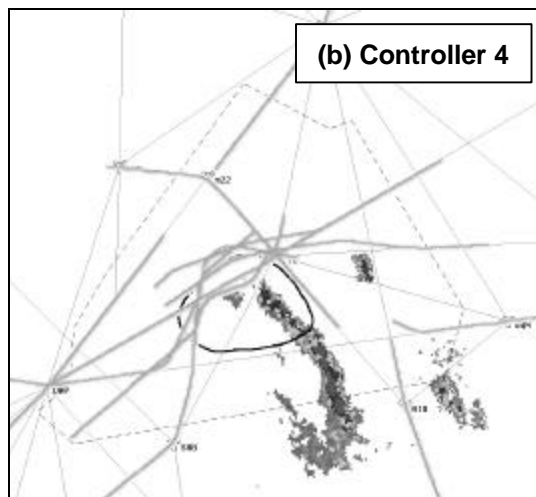
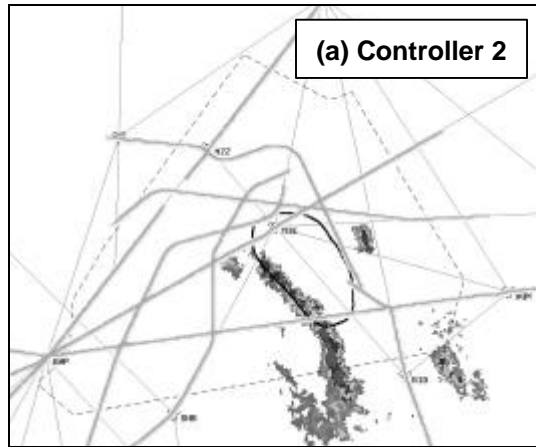


Figure 42. ATC weather recall results with tracks overlaid (Scenario 1b)

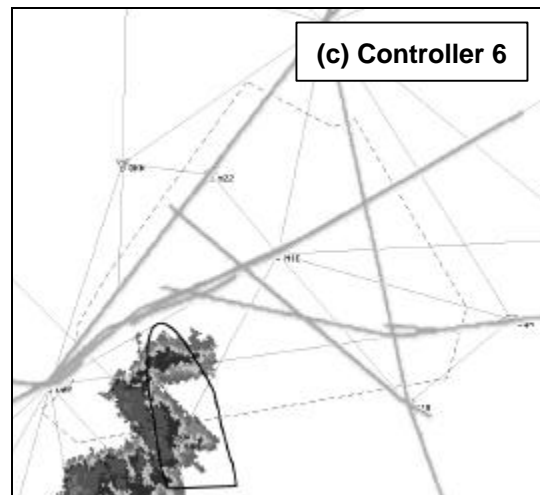
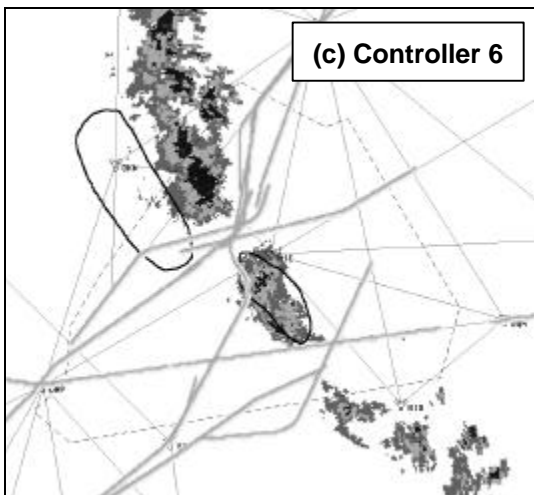
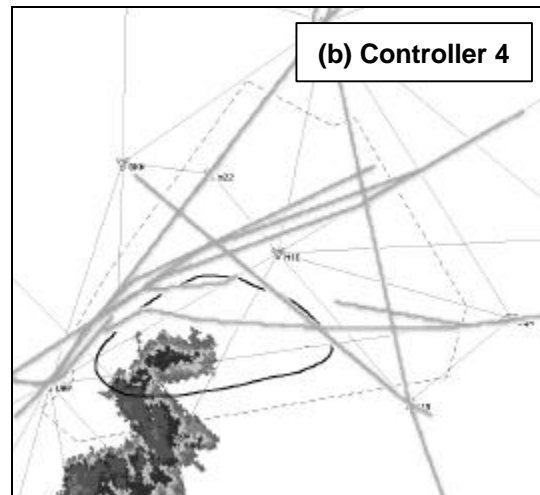
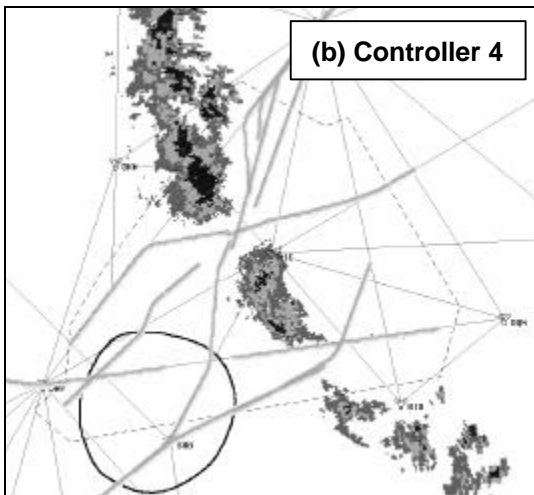
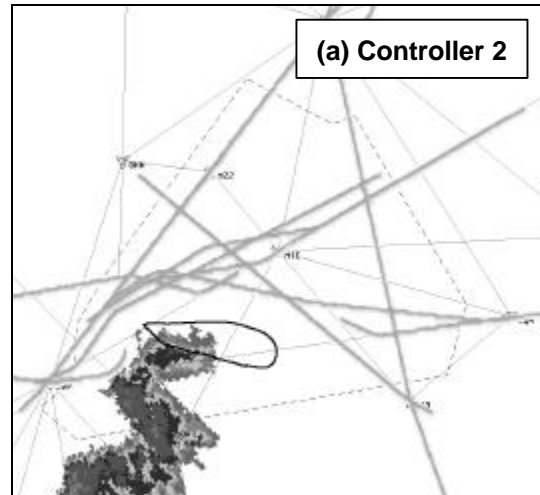
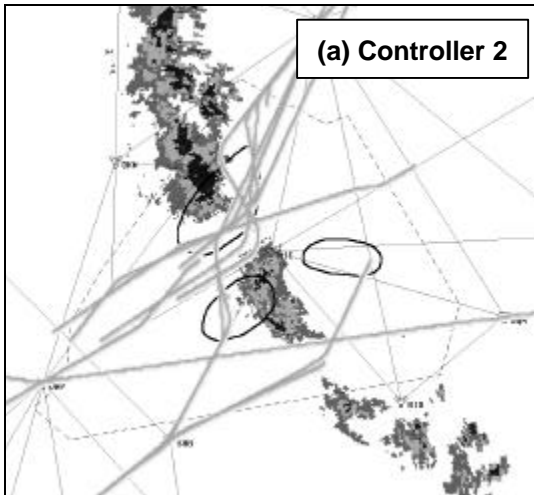


Figure 43. ATC weather recall results with tracks overlaid (Scenario 2b)

Figure 44. ATC weather recall results with tracks overlaid (Scenario 3b)

In analyzing this data, it must be acknowledged that the recall task that the controllers were asked to perform for this analysis is subtly different than the task they typically perform when adverse weather conditions arise. The exercise for this experiment was a post-test task; data was not collected in real-time. In addition, the weather resources made available to the controllers were limited: the PVD did not feature the usual (albeit rudimentary) weather symbology; the controllers did not have access to an advanced weather display or weather briefing, which is typically a few feet away at the supervisor’s desk; and, the controllers were not permitted to use the grease pencil method.

4.2 Separation Violations

In the 36 test scenarios, five separation violations were observed, all of which occurred with the data link disabled. A loss of separation was defined in accordance with en route ATC standards: lateral separation of less than five nautical miles and vertical separation of less than 1000 feet. Figure 45 indicates the closest points of approach for the five separation violations. The upper right corner corresponds to the 5-nm, 1000-foot separation standard which defines a loss of separation for en route operations. The lower left corner corresponds to zero separation—a collision.

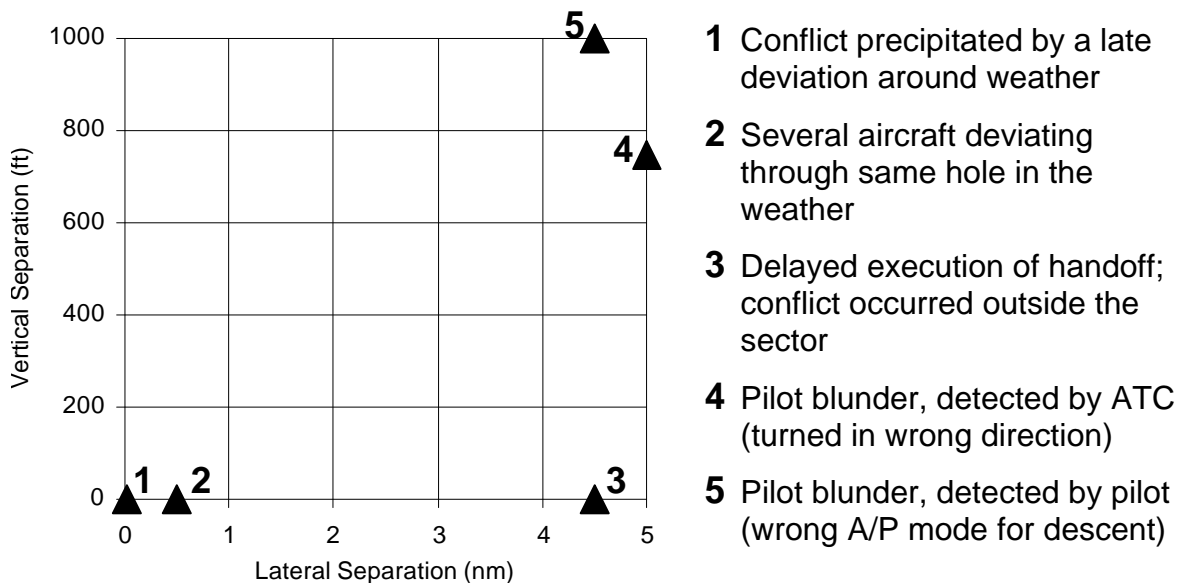


Figure 45. Closest points of approach for the five separation violations

It is important to note that several factors made the controllers' tasks in these test scenarios unusually demanding. First, the test scenarios were challenging by design. The sector's small size coupled with higher-than-typical traffic densities increased the tempo of activity in the sector and shortened the planning timeframe from strategic to tactical. Furthermore, controllers were operating an air traffic sector other than their usual "home" sector and did not have the benefit of a conflict alert function or a D-side controller to assist them.

The five separation violations fall into two general categories. As will be discussed, events #1 and #2 were serious near-miss incidents which appear to be attributable to poor situation awareness, in this case the byproduct of severe weather and traffic constraints. Events #3, #4 and #5 were borderline cases attributable to high workload and distraction on the part of the controller, pilot or pseudo-pilot.

Events #1 and #2 occurred as several aircraft were attempting to deviate through a corridor in a weather front. In each case, with no weather information available, the controllers had difficulty anticipating deviation requests and developing a coherent flow strategy. As a result, they had to react to several urgent requests in a short time period.

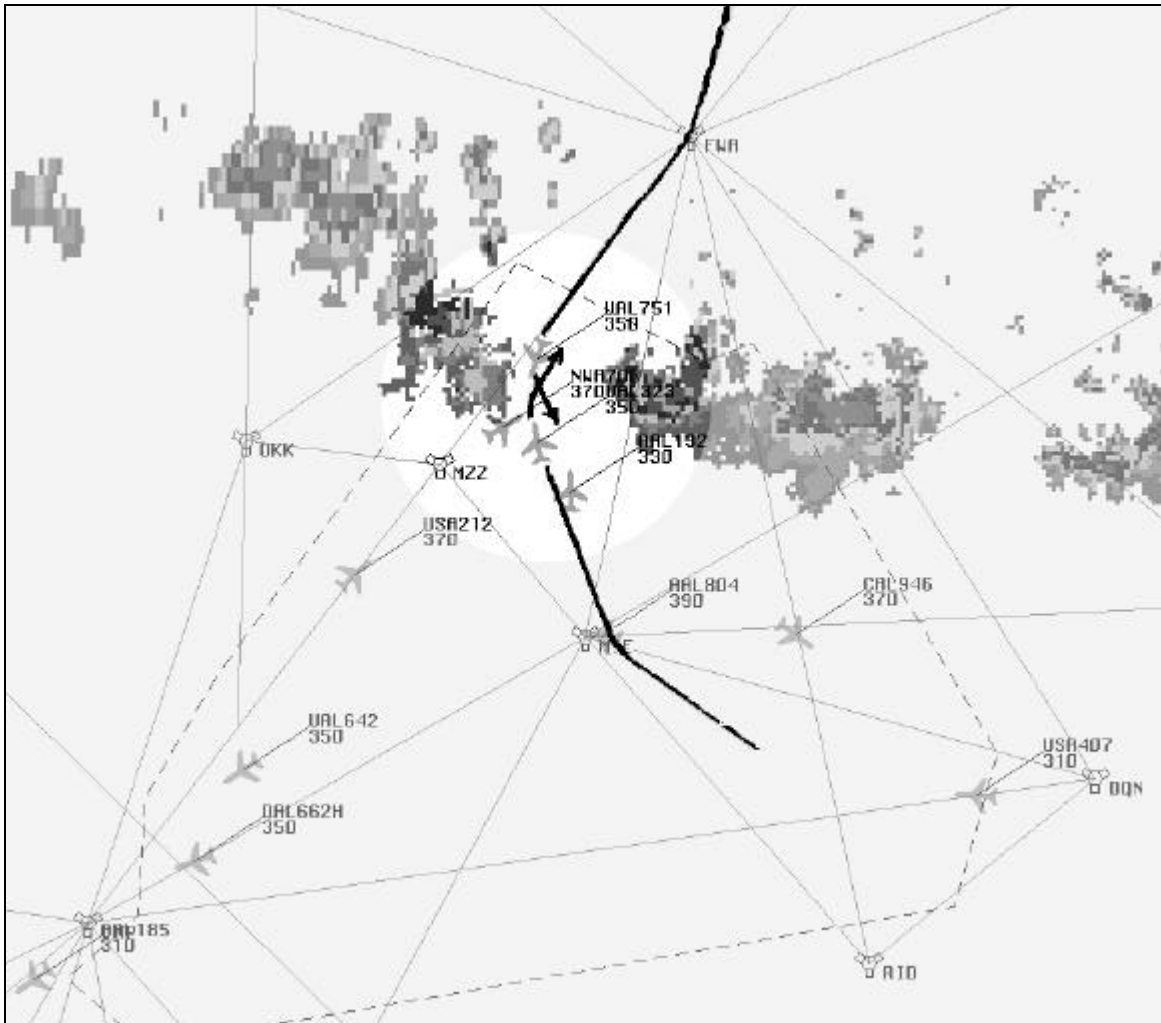


Figure 46. Loss of separation #1 (CPA: <100 ft & 0 ft.)

A snapshot of event #1 is provided in Figure 46. UAL323 was descended from FL370 to FL350 near RID to separate conflicting traffic. As the scenario developed, four aircraft requested clearance through the same hole in the weather. In attempting to accommodate all of their requests, the controller apparently lost awareness that two aircraft were co-altitude and in opposite directions through the hole. UAL323 and UAL 751 eventually closed to within 100 feet. The controller recognized the situation after the two aircraft had passed.

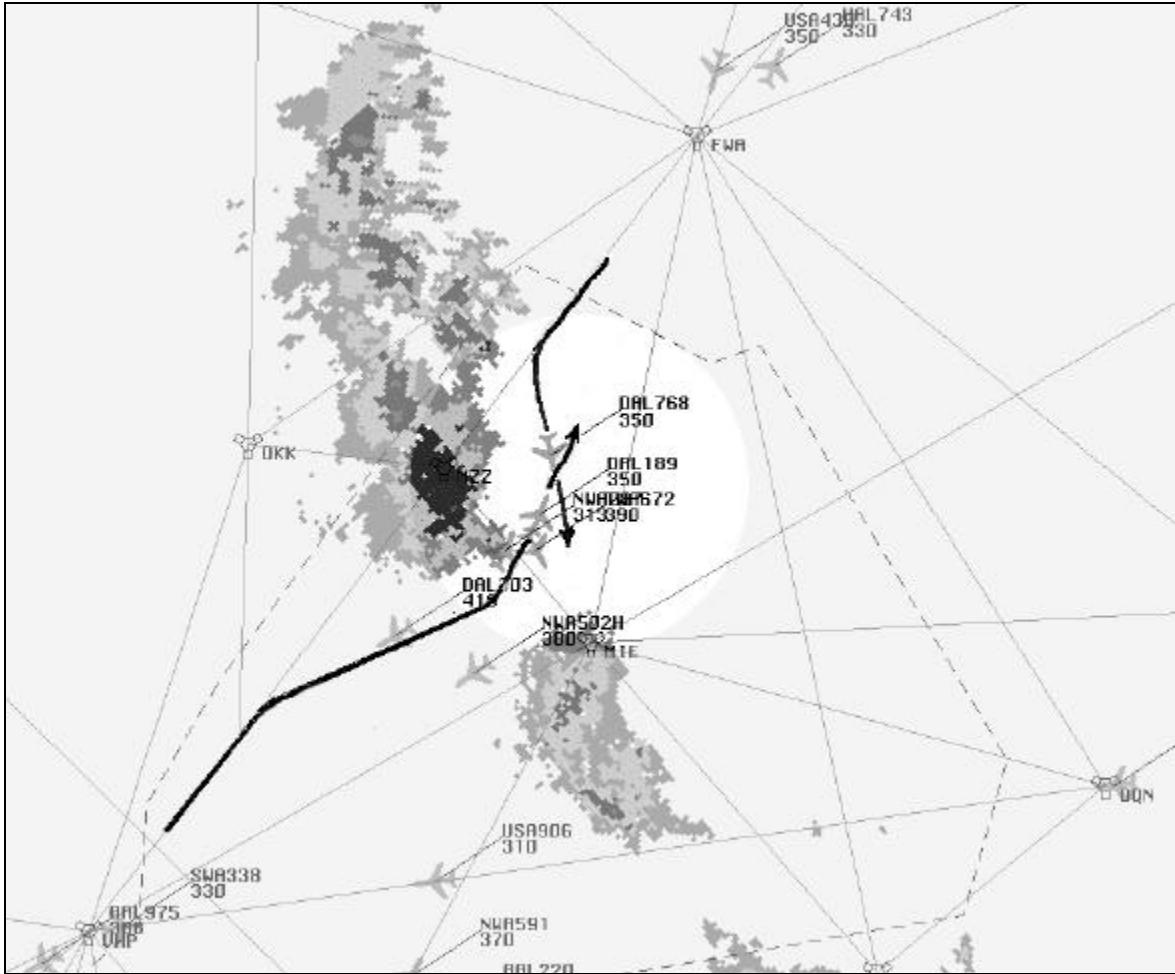


Figure 47. Loss of separation #2 (CPA: 0.5 n.m. & 0 ft.)

A snapshot of event #2 is provided in Figure 47. DAL189 was descended from FL370 to FL350 southwest of MIE to make way for other traffic coming through the hole. DAL768 requested and received a last-minute clearance to deviate 15 miles to the left of its FWA–VHP course. These two aircraft eventually came within one half mile of one another. The controller recognized the conflict after the two aircraft had passed.

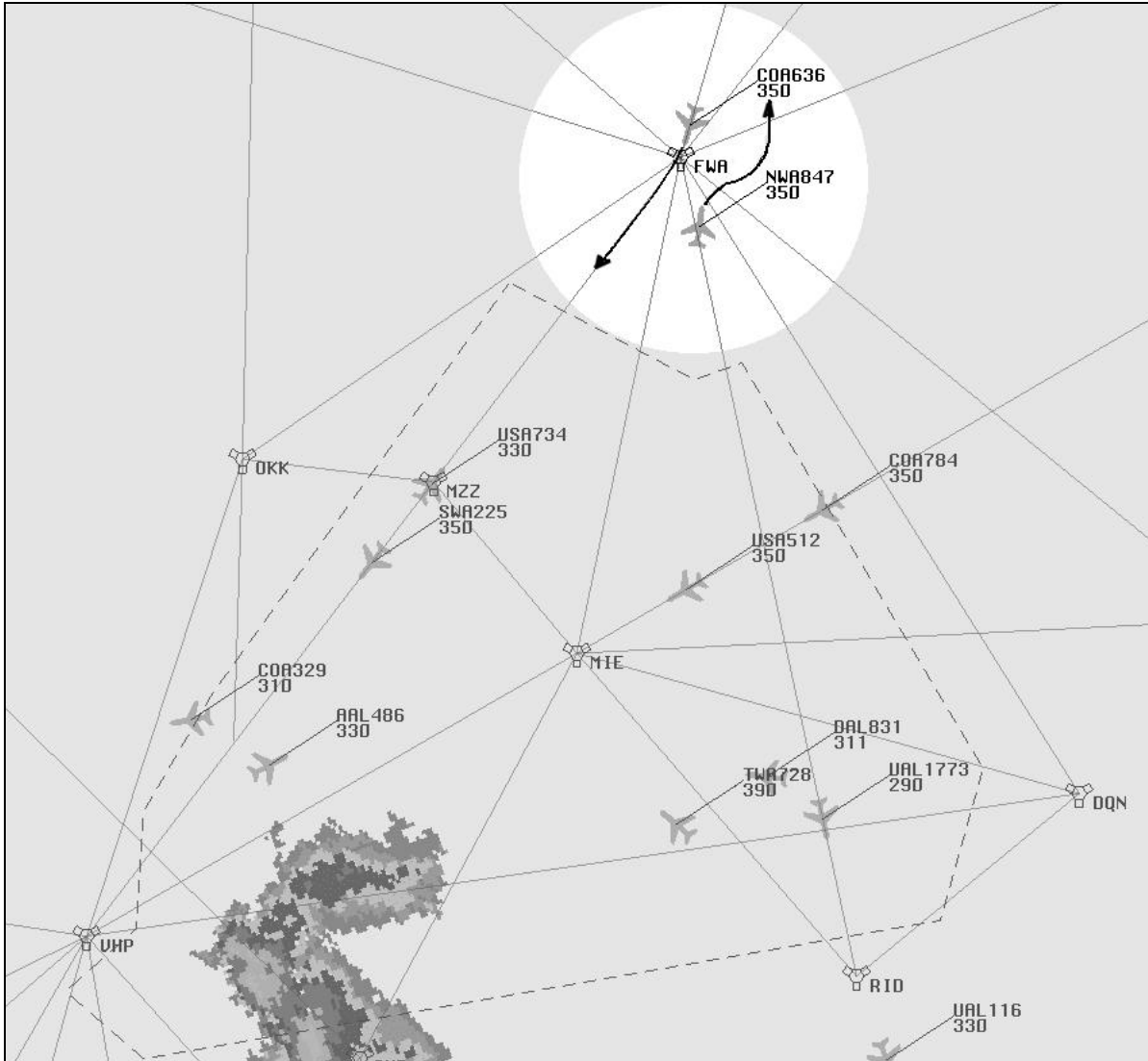


Figure 48. Loss of separation #3 (CPA: 4.5 n.m. & 0 ft.)

Event #3 occurred outside the sector boundary between an incoming aircraft and an outgoing aircraft, as shown in Figure 48. At the time of the encounter, the outgoing aircraft was under the control of the subject controller, but the incoming aircraft was not. The incoming and outgoing aircraft were both level at FL350 on headings of 190 degrees and 340 degrees, respectively (just within the 180-to-359 degree heading-for-altitude standard). While responding to a request from DAL831 (the subject aircraft) for a ride report, the subject controller recognized the impending conflict at FWA and issued avoidance instructions to both COA636 and NWA847.

Events #4 and #5 occurred as a result of pilot blunders. In event #4 (see Figure 49), the pseudo-pilot inadvertently made a right turn into traffic instead of a left turn away from traffic as commanded by ATC. The controller recognized the blunder before the pilot and issued instructions to resolve the situation. In event #5 (see Figure 50), the subject pilot selected an inappropriate autopilot mode midway into a crossing descent. This resulted in an unintended 500-foot climb before the pilot was able to recognize and correct his mistake. The interruption in the descent profile resulted in a loss of separation.

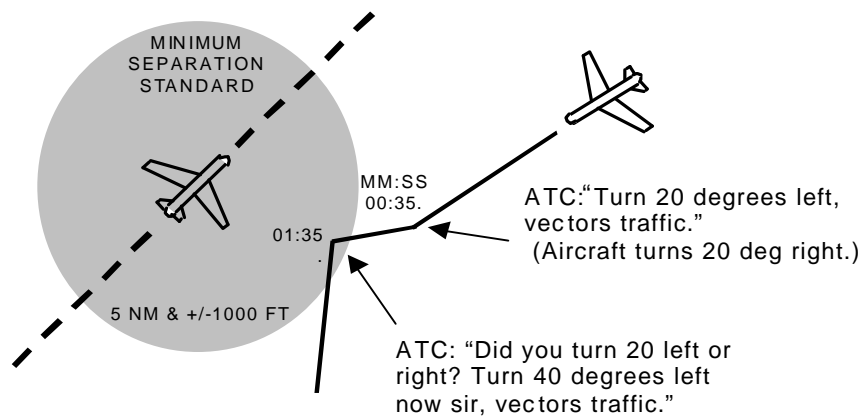


Figure 49. Loss of separation #4 (CPA: 5 n.m. & 750 ft.)

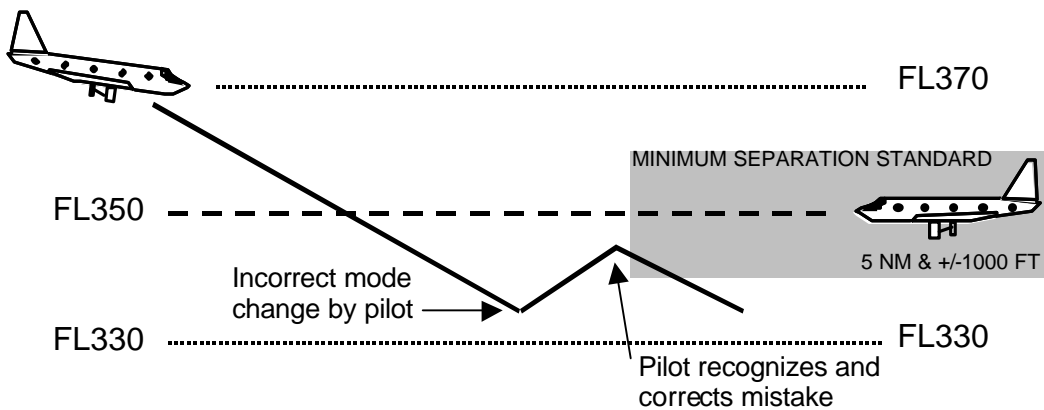


Figure 50. Loss of separation #5 (CPA: 4.5 n.m. & 1000 ft.)

The fact that all of the separation violations occurred in the non-datalinked environment suggests that shared information may help controllers build and maintain situation awareness with regard to separation issues. In events #1 and #2, it appears that controllers did not have sufficient situation awareness to adequately anticipate and plan for the disturbances in the traffic flow brought about by the severe weather constraints. In events #3, #4 and #5, high workload in one part of the sector appears to have caused the controller to be less vigilant with regard to handoff status and aircraft conformance in another part of the sector.

4.3 Communication and Negotiation

All radio communication was recorded, coded by category and topic, and analyzed. Figure 51 illustrates how the transactions conducted over the voice channel changed with the introduction of the data link. As shown at the left, the number of transactions between the pilot and controller decreased slightly when the data link was introduced. Despite this decrease, the number of transactions for negotiating re-route clearances remained virtually constant, and the number of other transactions (including traffic advisories, ride reports, etc.) decreased. These results are not statistically significant, however.

Figures 52 and 53 illustrate how the character of pilot-controller interaction changed when the data link was introduced. Figure 52 shows that requests by the subject pilot and commands by the subject controller (to all aircraft) both dropped slightly, albeit not significantly. With the data link enabled, the subject pilot and subject controller made more voluntary suggestions to one another for specific route amendments. For example, consider the following exchange from scenario 2b (refer to Figure 15):

AAL303: INDY CENTER AMERICAN THREE OH THREE, FLIGHT LEVEL
THREE NINE ZERO, LIKE TO DEVIATE HEADING ABOUT TWO
FIFTEEN FOR ABOUT FORTY MILES FOR WEATHER.

ATC: AMERICAN THREE ZERO THREE, ROGER. I SHOW A BREAK IN
THE WEATHER THAT'S ABOUT YOUR ONE O'CLOCK. HAVE YOU
CONSIDERED A DEVIATE ABOUT TEN TO THE RIGHT AND THEN
DIRECT INDY?

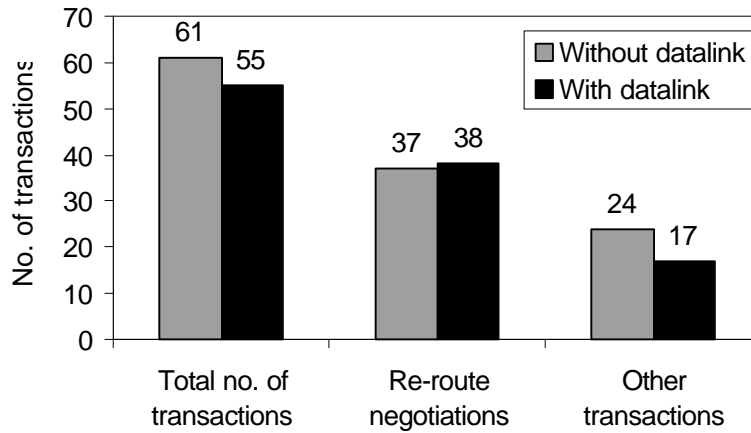


Figure 51. Voice communication transactions by topic

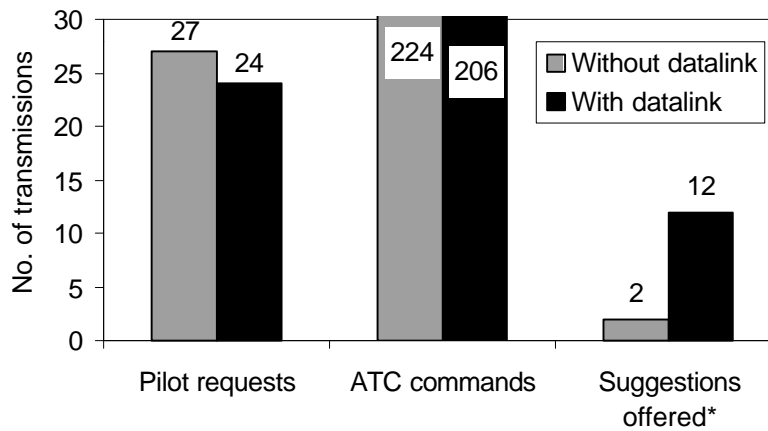


Figure 52. Voice transmissions by category

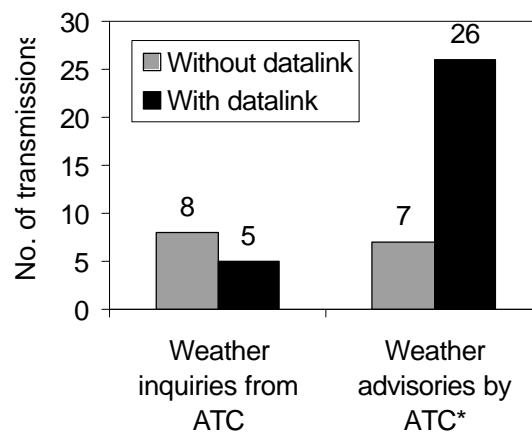


Figure 53. ATC voice transmissions regarding weather

*Indicates a statistically significant result.

The deviation suggested by the controller was a more direct path than the pilot's requested deviation, saving the pilot approximately four minutes' flying time. There was no apparent benefit to the controller other than the satisfaction of having provided improved service. Furthermore, the controller appeared to incur additional workload, as the suggested deviation required careful sequencing with merging traffic from the north. This kind of verbal exchange of re-routing ideas, options and preferences was rarely evident when the data link was disabled. This result is marginally statistically significant at the 9% level ($p < 0.09$). In addition, Figure 53 illustrates that controllers were more proactive in providing weather advisories to pilots when they had the weather information overlay. This result is statistically significant at the 1% level ($p < 0.01$). Together these results are indicative of more cooperative interaction between pilots and controllers.

4.4 Workload

Pilot and controller workload was measured using NASA-TLX. The results exhibited high variance, both between subjects and within subjects, as indicated by the wide error bars in Figures 54 & 55. In general, the availability of shared information did not appear to affect pilot or controller workload in any systemic way.

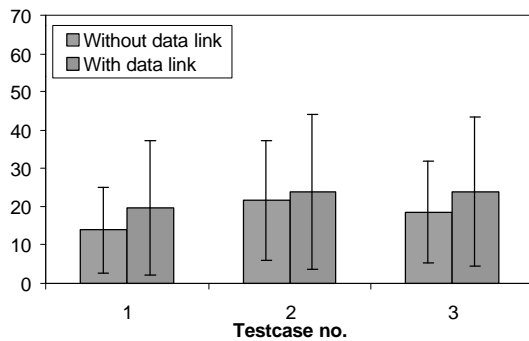


Figure 54. Pilot composite workload

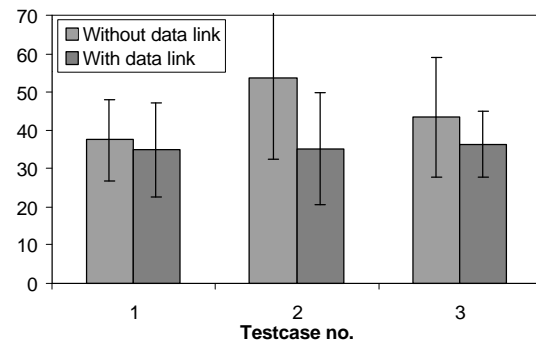


Figure 55. Controller composite workload

4.5 Subjective Responses

At the conclusion of each test session, subjects were asked to provide a subjective rating of the value of the shared information on a scale ranging from "very detrimental" to "neutral" to "very valuable". Table 6 summarizes the responses of pilots and controllers. Pilot feedback was unanimously favorable, and all of the controllers rated the information as "very valuable".

Table 6. Subjective ratings of the value of shared information

	Pilots	Controllers
Very valuable	✓✓	✓✓✓✓✓✓✓
Somewhat valuable	✓ ✓✓✓	
Neutral		
Somewhat detrimental		
Very detrimental		

While controllers were enthusiastic in their support for the shared weather display, their opinions on sharing their traffic information with the cockpit were mixed. Some controllers suggested that it could be useful to controllers and pilots when sequencing aircraft in the terminal area. Others expressed concern that arming pilots with such information might make pilots "less complacent" with regard to their approved clearances or assigned vectors. During the course of this experiment, pilot-controller exchanges were observed that validate each of these opinions.

4.6 Discussion

It was anticipated that the sharing of information would change the balance of information and, given an environment of competing goals between pilots and controllers, introduce instability into the air traffic control system in the form of increased negotiation and contention. The evidence does not seem to support this hypothesis. While there were instances of contention and extended negotiation, such instances were rare

when compared to the overall spirit of cooperation and teamwork between controller and pilot, even when cooperation meant acting contrary to their supposed competing goals.

There is the possibility that the test subjects may have been predisposed to cooperative behavior. The test subjects for this experiment were unpaid volunteers and for the most part self-selected. As such, they may represent the more charitable, cooperative elements of their populations. In addition, knowing that their words and actions would be recorded and studied, subjects may have made an effort—conscious or subconscious—to be less egocentric and more synergistic in their problem-solving approaches. Furthermore, due to the close proximity of the cockpit and ATC simulators, the two subjects had the opportunity to become acquainted over the course of the day. As a result, the subjects tended to establish a friendly rapport that would not typify pilot-controller relations on the line. This rapport may have biased the subjects toward more cooperative, compliant behavior than is typical in actual operations.

The availability of a NEXRAD weather overlay clearly benefited the controllers and the control system in general. Without the weather overlay, controllers had a difficult time anticipating the effects of weather on the traffic flow (i.e., building level 3 SA). As a result, controllers were faced with a high number of tactical deviations requiring time-critical conflict management. Attention to these immediate-term situations generally came at the expense of longer-term strategic planning. Furthermore, without good situation awareness regarding the location of weather-impacted areas, the controllers' primary conflict resolution strategy was simply to meet the pilots' re-route requests wherever possible. However, as suggested by the situation awareness analysis in Chapter 2, the pilots' requests typically reflected a desire to select the most efficient route that would avoid the weather; the impact of said route on the broader traffic flow was not an apparent goal of pilots. Thus, in attempting to honor pilots' re-route requests, controllers were in effect subordinating their own goal of maintaining an orderly traffic flow to the pilots' goal of selecting an efficient route. Ultimately, several separation violations occurred.

When the weather overlay was provided, controllers were better able to anticipate aircraft needs and constraints, enabling them to shift their attentions from crisis

management and resolution to strategic planning and prevention. To varying degrees, the controllers adopted a more proactive role in routing aircraft around weather. Whereas in the non-datalinked configuration controllers typically waited for pilots to request deviations for weather and deferred to them for routings, in the datalinked configuration controllers often assigned vectors around weather in advance of any pilot requests. In such cases, pilots did not attempt to inject their goal of selecting the most efficient route into the re-routing decision. The controllers were free to select route amendments which optimized the overall traffic flow. In effect, this subordinated the pilots' goal of selecting an efficient route to the controllers' goal of maintaining an orderly traffic flow. No separation violations occurred in this datalinked configuration. These results illustrate how the allocation of information can influence the authority structure.

One controller expressed that it was his goal to assign the vectors before the pilot asked for them, since the earlier the vectors were assigned, the more likely the pilot would be to accept them. Indeed, pilots accepted all of the controller-initiated weather vectors without contention, even when the vectors took them on a different routing than they had requested in the same scenario performed without the data link. Thus, the controller's use of the weather information as a competitive advantage went unchecked by pilots, and the stability of the control system was not adversely affected.

The markedly improved performance (in terms of separation assurance) and strong subjective preference of controllers for the weather display suggests that weather information of a quality equivalent to NEXRAD should be made available on the PVD.

Chapter 5 Conclusions

It is generally thought that by sharing information between pilots and controllers, situation awareness will be improved on either side. With improved situation awareness, more collaboration between the two parties is anticipated. Such collaboration is expected to lead to improved performance on an individual and system-wide basis.

The results of this study tend to corroborate the conventional wisdom. By sharing traffic and weather information between pilots and controllers, situation awareness with respect to traffic and weather was improved for both parties. Sharing of this information did lead to more collaborative interaction between the pilots and controllers, as evidenced by more frequent advisories and the unsolicited exchange of suggestions for alternative, more favorable routings. With improved situation awareness and increased air-ground cooperation, safety was improved, as evidenced by a reduction to zero in the number of separation violations.

Outside the laboratory, the effect of shared information on pilot-controller interaction will depend on the degree to which pilots and controllers approach their work with the same spirit of cooperation as was evidenced in this study. When the pressures and realities of line operations begin to weigh on the pilot-controller relationship, it is possible that the spirit of cooperation may succumb to the more competitive, distributive interests identified in the situation awareness analysis associated with this study. In such cases, it is possible that by sharing information between the pilot and controller, re-route negotiations could become more protracted and more contentious.

Independent of the effects of shared information on pilot-controller interaction, there appears to be a clear benefit to the provision of NEXRAD-type weather information to center controllers as an overlay on the PVD. Such displays appear to significantly improve controller situation awareness with respect to weather. More importantly, there appears to be a corollary benefit by which controllers are able to acquire better situation awareness with respect to traffic, particularly at the higher levels: comprehension and projection. In so doing, controllers appear to shift from reactive control strategies to more proactive ones, resulting in safer, more routine traffic operations.

In considering the addition of a NEXRAD weather overlay to the PVD, one significant benefit is the relative simplicity with which it could be implemented. The radar technology exists. The radar equipment is fielded and operational. The data dissemination networks are widespread and inexpensive (an air-ground data link is not required). Weather data products are commonly available; indeed, they are already found at most supervisors' desks, just a few feet behind controllers' heads. The remaining challenge is a relatively low-technology, low-risk one: integrating graphical weather products into the plan view display.

The FAA's proposed NAS architecture includes provisions for an improved graphical display of weather information for controllers. To accomplish this, current plans call for development and deployment of two new systems: a Weather and Radar Processor (WARP) and an en route ATC console called the Display System Replacement (DSR). The WARP will collect radar data and generate and disseminate a mosaic of NEXRAD images to the DSR for display with aircraft targets.

Although the WARP is already operational at all U.S. ARTCCs, it will need to be upgraded to stage 1 in order to deliver NEXRAD imagery to the DSR (Kalani, 1999). The stage 1 upgrade is scheduled to be operational at the Seattle Center in 2000. Installation at the remaining Center facilities is planned for 2000-2001, by which time DSR also is expected to be operational at all U.S. ARTCCs (Johnson, 1999). The findings of this report argue that deployment of these systems be accelerated wherever possible.

Providing controllers with a better picture of the weather situation certainly will not replace the need for air-ground data link. In fielding such systems in the future, it is hoped that designers will be mindful of the human components of the system, the different perspectives and interests that each brings to a shared problem, and how information can be employed to foster cooperative interaction and stability in the system.

References

- Amonlirdviman, Keith, Farley, Todd C., Hansman, R. John, Ladik, John F., & Sherer, Dana Z. (1998). A distributed simulation facility to support human factors research in advanced air transportation technology. SISO Simulation Interoperability Workshop, Orlando, Florida.
- Cashion, Patricia, Macintosh, Margaret-Anne, McGann, Alison, & Lozito, Sandra. (1997). A study of commercial flight crew self-separation. AIAA/IEEE Digital Avionics Systems Conference Proceedings, Irvine, California, October 26-30, Vol. 2, pp.6.3-18 to 6.3-25.
- Endsley, Mica R. (1995). Toward a theory of situation awareness in dynamic systems. *Human Factors*, 37(1), pp. 32-64.
- Endsley, Mica R., Farley, Todd C., Jones, William M., Midkiff, Alan H., & Hansman, R. John (1998). Situation awareness information requirements for commercial airline pilots. ICAT-98-1, MIT International Center for Air Transportation, Cambridge, Massachusetts.
- Endsley, Mica R., & Rodgers, Mark D. (1994). Situation awareness information requirements for en route air traffic control. (DOT/FAA/AM-94/27), Washington, D.C.: Federal Aviation Administration Office of Aviation Medicine.
- Endsley, Mica R., & Jones, William M. (1997). Situation awareness information dominance & information warfare. AL/CF-TR-1997-0156, Wright-Patterson AFB, Ohio.
- FAA. (1998a). Federal aviation regulations. FAR 91.3, Federal Aviation Administration, Washington, DC.
- FAA. (1998b). FAA Order 7110.65L, Air traffic control. Paragraph 2-10-1c.1.(a), Air traffic control handbook, Federal Aviation Administration, Washington, DC, February 26, 1998.
- FAA. (1998c). National airspace system architecture (draft). FAA Office of System Architecture and Investment Analysis (ASD-1), Federal Aviation Administration, Washington, DC.
- Falcone, Rich, Kollman, Kevin, Leber, Bill, Moffatt, John, Sandusky, Lorraine, Shanz, Art, Wambsganss, Mike, & Wetherly, Jim. (1998). Demonstrating an improved weather awareness system for CDM. *Journal of Air Traffic Control*, July–September, 1998, pp. 50–58.
- Foushee, Clayton H., Lauber, John K., Baetge, Michael M., & Acomb, Dorothea B. (1986). Crew factors in flight operations: III. The operational significance of exposure to short-haul air transport operations. NASA Technical Memorandum 88322.
- Hansman, R. J., Kuchar, J. K., Clarke, J. P., Vakil, S. V., Barhydt, R., & Pritchett, A. R. (1997). Integrated human-centered systems approach to the development of advanced air traffic management systems. 1st USA/Europe ATM R&D Seminar, Saclay, France.

- Hart, S. G., & Staveland, L. E. (1988). Development of NASA-TLX (Task Load Index): Results of empirical and theoretical research. In *Human Mental Workload*, P. A. Hancock and N. Meshkati (Eds.), North Holland Press, Amsterdam.
- Johnson, Eric N. (1995). Multi-agent flight simulation with robust situation generation. Master's degree thesis, Department of Aeronautics & Astronautics, Massachusetts Institute of Technology, Cambridge, Massachusetts.
- Johnson, Jay (1999). FAA AUA-460, WARP Product Team. Personal communication. January 13, 1999.
- Kalani, Nannette (1999). FAA AUA-460, WARP Product Team. Personal correspondence. January 13, 1999.
- Kanki, Barbara G., & Prinzo, O. Veronika (1996). Methods and metrics of voice communications. (DOT/FAA/AM-96/10) Washington, D.C.: Federal Aviation Administration Office of Aviation Medicine.
- Lewicki, Roy L., Saunders, David M., & Minton, John W. (1997). *Essentials of Negotiation*, McGraw-Hill.
- Midkiff, Alan H., & Hansman, R. John. (1992). Identification of important "party line" informational elements and the implications for situational awareness in the datalink environment. ASL-92-2, MIT Aeronautical Systems Lab, Cambridge, Massachusetts.
- Prinzo, O. Veronika, & Britton, Thomas W. (1995). Development of a coding form for approach control/pilot voice communications. (DOT/FAA/AM-95/15) Washington, D.C.: Federal Aviation Administration Office of Aviation Medicine.
- Pritchett, Amy R., Hansman, R. John, & Johnson, Eric N. (1996). Use of testable responses for performance-based measurement of situation awareness. International Conference on Experimental Analysis and Measurement of Situation Awareness, Daytona Beach, Florida.

Appendix A Commercial Airline Pilot Goal Hierarchy

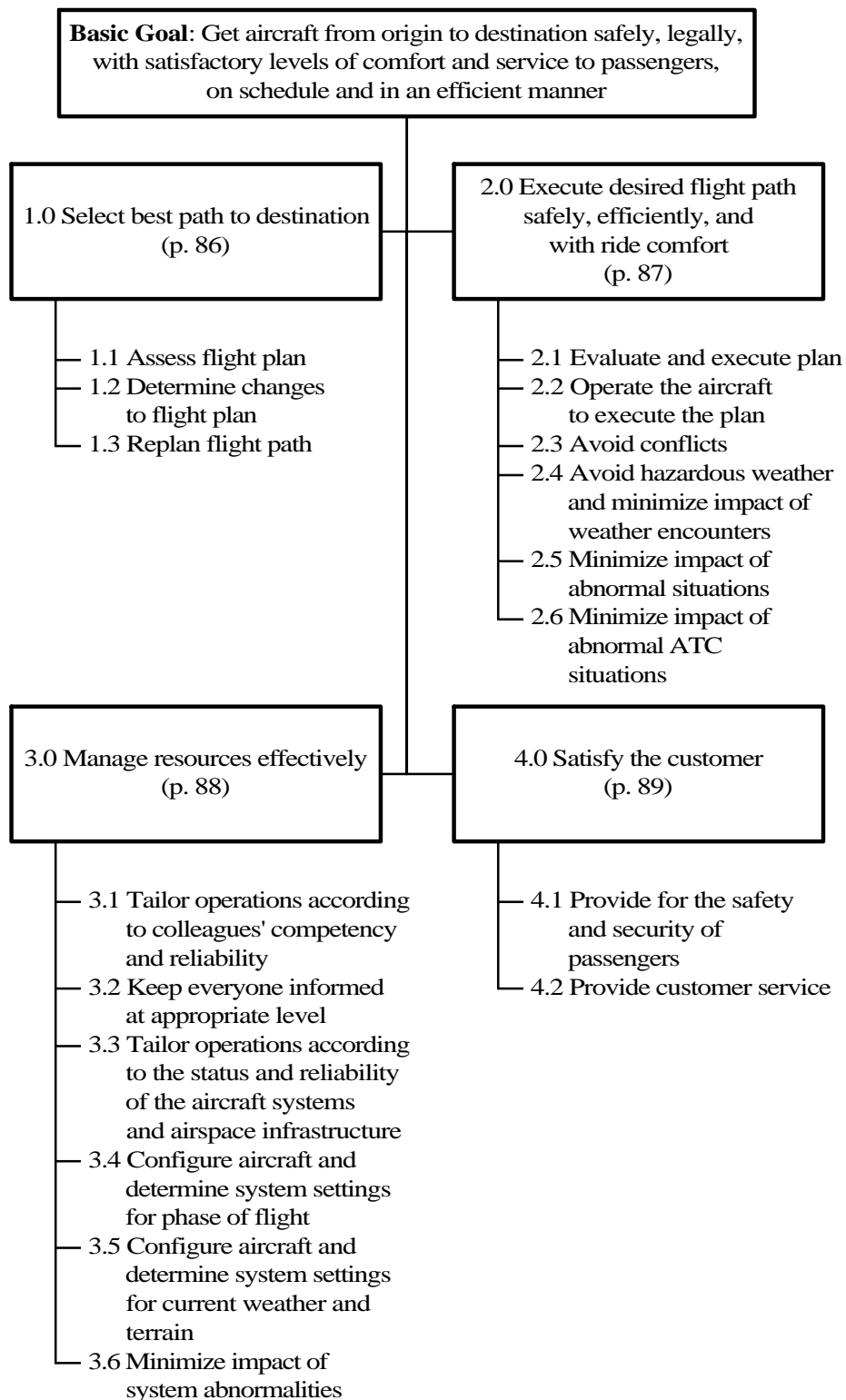
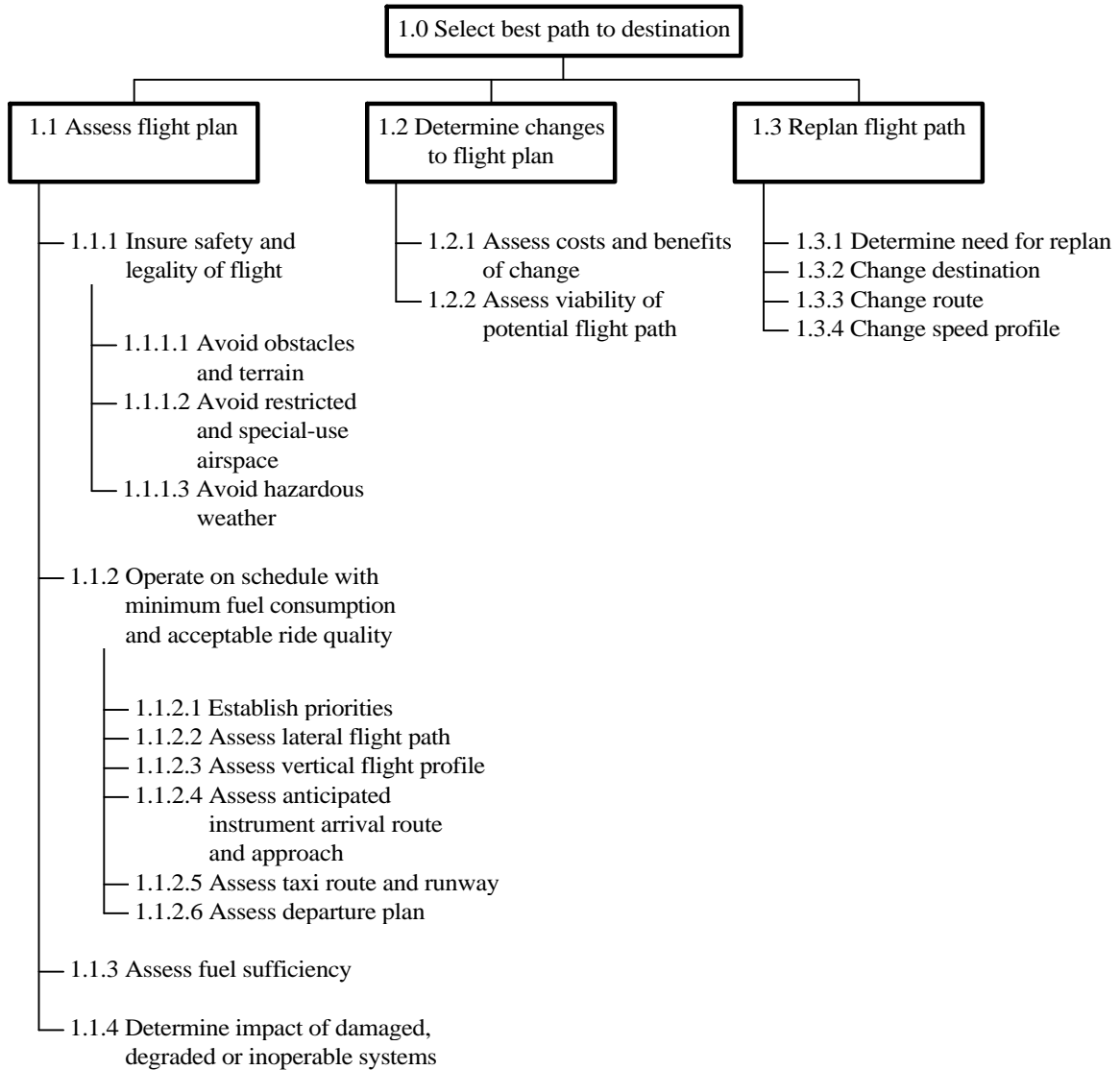
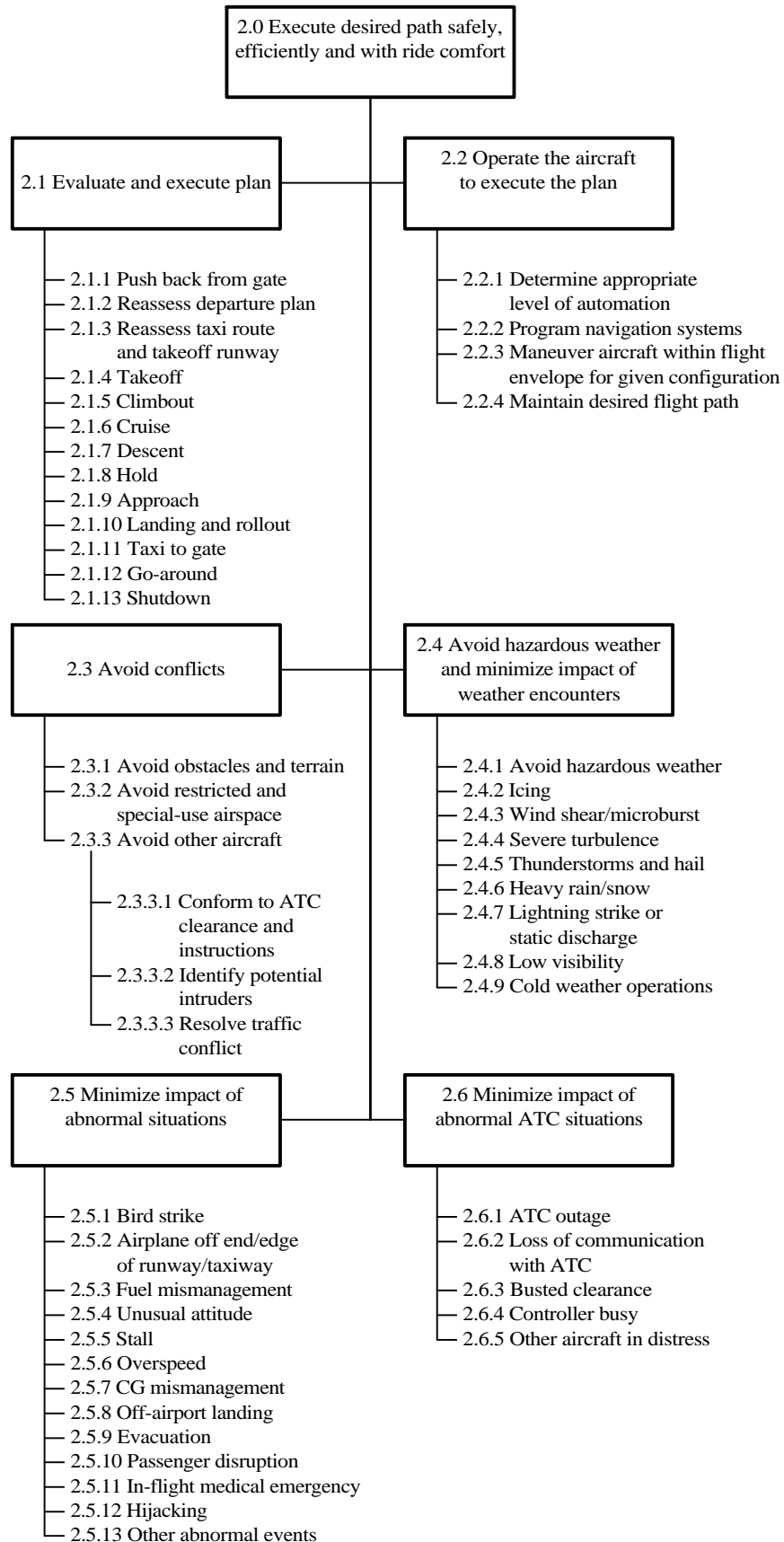
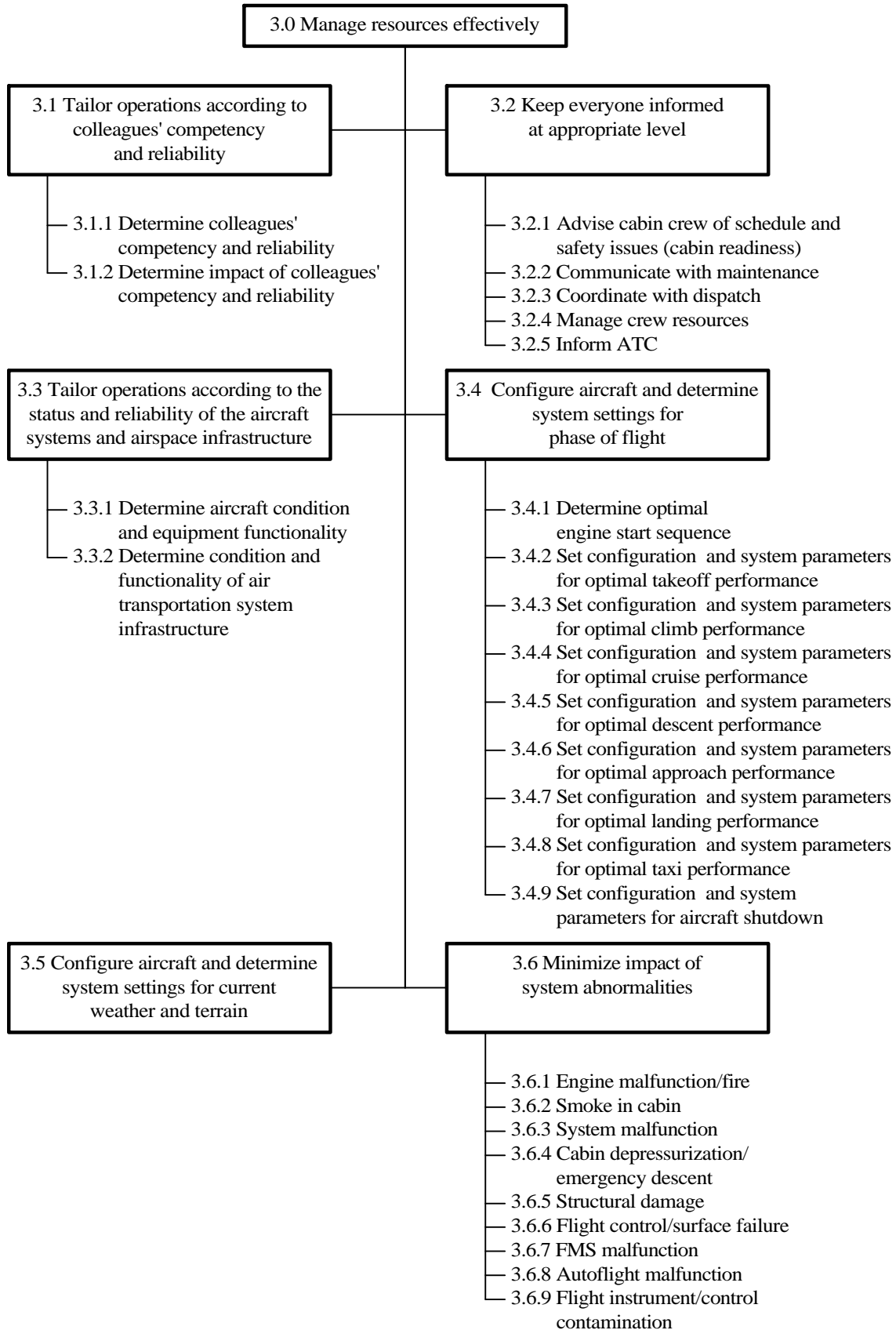
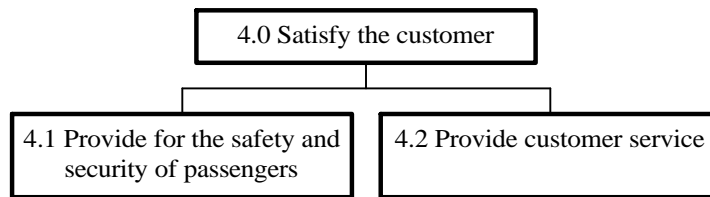


Figure 56. Commercial Airline Pilot Goal Hierarchy (5 pages)









Appendix B Commercial Airline Pilot Situation Awareness Information Requirements

LEVEL 1

Aircraft data

- Call sign
- Weight
- Weight distribution
- Center of gravity
- Aircraft type
- Engine type/capabilities
- Equipment on board
- CAT II/III qualified
- First aid on board
- Performance capabilities/restrictions
 - Maintenance carryover items

Aircraft state

- Heading
 - Magnetic
 - True
- Altitude
 - Absolute altitude
 - Pressure altitude
 - True altitude
 - Density altitude
 - Temperature
 - Elevation
 - Altimeter setting
- Airspeed
 - Indicated
 - Max and min airspeed for current configuration
 - Ground speed
- Airspeed rate of change
- Vertical speed
- Acceleration / deceleration
- Position
- Pitch attitude
- Roll attitude
- Turn rate
- Configuration
 - Gear position
 - Flap position
 - Slat position
 - Spoiler position
 - Stabilizer trim

- Elevator trim
- Thrust setting
- Engines spooled evenly for takeoff
- Fuel
 - Fuel quantity
 - Fuel temperature
 - Fuel type
 - Fuel distribution
 - Fuel burn rate
 - Arrival fuel requirement
- Engine area clear/blocked
- Braking force
- Reverse thrust
- Stall
- Angle of attack
- System settings
 - Anti-ice
 - Packs
 - Autopilot engagement
- Wait time for de-ice
- De-ice fluid
 - Type
 - Mix ratio

Equipment malfunctions

- Areas of aircraft damage
- Operational status of aircraft systems
 - Reliability of systems
 - Severity of system failure/degrade
 - Validity of system failure/degrade
 - Pneumatic
 - Air conditioning
 - Pressurization
 - Thrust reversers
 - Hydraulic
 - Flight control
 - Flaps, slats

- Control surfaces
- Spoilers
- Fuel
- Electrical
- Landing gear, brakes, anti-skid and nose-wheel, auto-braking
- Navigation and instrumentation
 - Altimeter setting
 - Navigation system alignment
 - FMS programming
 - INS
 - GPS
 - ACARS
- Powerplant
 - Engines
 - APU
- Autoflight
 - Autopilot
 - FMS
- Weather radar
- Anti-ice
- Fire protection
- Audio panel
- Communication system
- Emergency systems and equipment
 - Oxygen
 - Smoke goggles
- Doors
 - Unsafe exits
- Lights
- Warning systems
- Cockpit voice recorder

- Operational status of ATC/NAS systems
 - System failures/degrades
 - Validity of system failure/degrade
 - Navigation aid
 - Communication system
 - Area of ATC outage
 - Command center outage
 - Confidence level in airspace systems functioning
 - Airport lighting

Airports

- Location
- Altitude
- Familiarity/recency
- Closures
- Altimeter setting
- Active runway(s)
- Approach in use
- Runway information
 - Length & width
 - Weight restrictions
 - Surface conditions
 - Closures
 - Procedures in effect
- Taxiway information
 - Width
 - Weight restrictions
 - Surface conditions
 - Slopes/grades
 - Closures/caution areas
 - Communication procedures
- Alternate airport
 - Refueling capabilities
 - Tug capabilities
 - De-icing capabilities
 - Passenger accommodations
 - Customs
 - Stairs/jetway
 - Availability of medical care
 - Served by airline

- Special information
 - Obstacles
 - Procedures
 - Noise abatement
 - Ground movement
 - Miss approach
 - Parallel approaches
 - Limitations
 - Landing curfew
- Lighting/signage
- Navigation ID and location

Flight plan

- Available routes
- Available altitudes
- Planned flight path
 - Distance
 - Altitude
 - Waypoints
 - Bearing
 - Discontinuities
 - Direction
 - Number of changes required
 - Difficulty of changes required
- Dispatcher's concurrence with plan
- Fuel reserve requirement
- Arrival fuel requirement
- Assigned runway
- Takeoff plan/settings/critical points
- Planned airspeed profile
- Planned climb profile
- Planned cruise altitude
- Planned cruise airspeed
- Planned descent profile
- Approach plan
 - Approach category
 - Reference speed
 - Initial approach altitude
 - Marker-crossing altitude
 - Final approach fix altitude

- Decision height
- Minimum descent altitude
- Missed approach point
- Scheduled time of arrival
- Terminal/Gate assignment
- Gate availability
- Door for deplaning

ATC

- Appropriate ATC organization/frequency
- Success rate of other aircraft requesting clearance
- English proficiency
- Local transition altitude
- Status of:
 - Checklists
 - Procedures
 - Briefings

Traffic

- Traffic on taxiway
- Traffic on runway
- Traffic on final
- Delays on ground
- Number of aircraft holding ahead
- Assigned sequence
- Spacing on final
- Expected Further Clearance time
- Other aircraft
 - Aircraft type/capabilities
 - Position
 - Altitude
 - Communications present
 - Altitude rate
 - Airspeed
 - Pilot competence/reliability
- TCAS instructions

Terrain/Obstacles

- Location
- Height
- Minimum altitudes

Weather

- Area affected
- Altitudes affected
- Conditions
 - Temperature
 - Dewpoint
 - Precipitation (level and type)
 - Visibility
 - Ceiling
 - Wind
 - Direction
 - Magnitude
 - Rate of change
 - Altitudes
 - Gusts
 - Crosswind component
 - Darkness
- Direction and speed of movement
- Intensity and rate of change of intensity
- Present ice buildup
- Ice accumulation rate
- Turbulence
 - Altitudes
 - Area
 - Intensity
- Speed gain/loss reports from other aircraft
- Wind shear location/severity
- Aircraft go-arounds
- Airport conditions
 - Precipitation accumulation
 - Runway visibility
 - CAT II/III status
 - Minimums

NAS

- Special use airspace
 - Boundaries
 - Status
 - Activation level
 - Limits and restrictions
- Navaid information
 - Frequency
 - Identifier
 - Availability
 - Course

Clearance

- Pushback clearance
- Departure clearance
- Taxi clearance
- Position and hold clearance
- Takeoff clearance
- Clearance to transition
- Descent clearance
- Approach clearance
- Landing clearance
- ATC instructions / vectoring
 - Assigned heading
 - Assigned altitude or altitude restriction
 - Assigned time-to-fix
 - Assigned spacing or sequence
 - Assigned airspeed or airspeed restriction
 - Time by which to comply with clearance
- Reporting points
- Assigned runway
- Assigned taxiway
- Restrictions

Passengers/cargo

- Number
- Cargo load
 - Weight
 - Hazardous material
 - Human organs
- Serious illnesses/injuries
- Medical personnel on board
- Sensitivity to descent rate
- Cabin temperature
- Cabin status
 - Seat belts on
 - Flight attendants seated
 - Carts stowed
- Type/status of meal service
- Provision status
 - Meals
 - Beverages
 - Pillows/blankets

- Communications equipment
- Movie
- Points of interest
- Hijacker(s)
 - Number
 - Profile
 - Demands

Human Resources

- Flight crew ability/reliability
 - Cat II/III qualified
 - Experience in aircraft
 - Experience in crew position
 - Currency in aircraft
 - Familiarity with route and airport
 - Correctness of tasks executed
- Cabin attendants ability/reliability
 - Experience
 - Number
 - Time on duty
 - Languages
- Self (pilot) ability/reliability
 - Fatigue
 - Stress
 - Attitude
 - Alertness
 - Time on duty
 - Workload level
- ATC ability/reliability
 - ATC facility
 - Stress/workload
 - Flexibility
- Ability/reliability of
 - Maintenance
 - Ground crew
 - Dispatch
- Communication channels
 - Dispatch
 - Maintenance

LEVEL 2

Aircraft parameters

- Confidence level in aircraft systems
- Deviation between aircraft state & aircraft limitations
- Deviation between current attitude and desired attitude
- Deviation between current gross weight and allowable gross weight
- Deviation between aircraft state & planned settings
- Severity of degrades
- Margin to V_1
- Airspeed relative to max turbulence penetration airspeed
- Margin to stall
- Validity of indications
 - Airspeed
 - Altitude
 - Fuel quantity
 - Stall
- Electrical power demands

Aircraft control

- Required control inputs
 - Heading correction
 - Pitch correction
 - Thrust correction
- Directional control responsiveness
- Stability of approach
- Available thrust
- Ramp maneuvering requirements
- Ability to abort / go around
- Deviation between current maneuver and optimal maneuver

Airport

- Availability of suitable alternate
- Ability to reach alternate

Flight planning

- Runway suitability
- Taxiway suitability
- Ability to reach destination
- Deviation between hold time and safe hold time

Flight plan conformance

- Deviation between plan and
 - Optimal profile
 - Safety/legal requirements
 - Aircraft capabilities
 - ATC requirements
- Fuel sufficiency
- Schedule deviation
- Track deviation
- Heading deviation
- Altitude deviation
- Airspeed deviation
- Allowable tolerance for deviations
- Discontinuities in plan

ATC conformance

- Deviation from assigned
 - heading or vector
 - altitude
 - time-to-fix
 - spacing
 - airspeed
- Conformance of clearance with expectations

Traffic

- Current separation from other aircraft
- Trajectory of other aircraft relative to ownship
- Closure rate
- Other aircraft's intended actions/path
- Maneuver
 - Aircraft
 - Timing
 - Type
- Aircraft ahead
 - Spacing
 - Type

- Wake turbulence areas

Passengers/cargo

- Comfort level
- Safety
 - Unsafe exits
 - Urgency of medical needs
- Hijacker(s)
 - Level of threat
 - Ability to meet demands

Compliance with Regulations/Procedures

- Compliance with noise abatement requirement
- Compliance with Standard Instrument Departure (SID) requirements
- Compliance with Standard Arrival Route (STAR) requirements
- Cleared to depart gate
- Distance from special use airspace
- Time until next communication needed
- Controller's understanding of own intent/needs

Terrain/Obstacles

- Relative distance, bearing and altitude
- Min/max climb/descent rate to clear obstacle

Priorities

- Relative priority of safety, legality, comfort schedule, efficiency

Customer satisfaction

- Acceptable schedule deviation
 - Connection requirements

Emergencies

- Risk of hazard to passengers/crew

Weather

- Confidence level in weather information
- Timeliness of information
- Hazard level
- Takeoff minimums
- Landing minimums
- Potential for
 - Icing
 - Thunderstorms
 - Turbulence
- Effectiveness of anti-ice measures
- Path of minimum weather exposure
- Deviation between current weather and projected weather
- Relative distance and bearing to weather areas

Impact

- Of aircraft malfunction / damage / abnormal condition on:
 - Aircraft performance/safety
 - Aircraft stability/control
 - Stopping ability
 - Flight plan
 - Operational parameters / system status
 - Procedures
 - Passenger/crew safety
- Of weather on:
 - Aircraft performance
 - Fuel system
 - Aircraft control
 - Passenger comfort
 - Passenger/crew safety
 - Flight plan
 - Takeoff
 - Landing
- Of traffic on:
 - Separation / safety of flight
 - Schedule

- Of change in flight plan / aircraft maneuver on:
 - Safety of flight
 - Legality
 - Schedule
 - Fuel usage
 - Ride quality
 - Passenger connections
- Of deviations on:
 - Safety of flight
- Of action on:
 - Hazard potential
 - Safety of flight
- Of clearance on:
 - Safety of flight
 - Schedule
 - Efficiency
- Of thrust level / configuration / system settings on:
 - Aircraft performance
 - Safety of flight
 - Passenger comfort/safety
 - Fuel usage/economy
 - ATC clearances/restrictions
- Of emergency on:
 - Safety of passengers/crew
- Of conditions/flight status/information on:
 - Passenger comfort
- Of automation on:
 - Safety of flight
 - Crew workload
 - Crew skills

Workload

- Time available to perform tasks
- To execute change in flight path
- Resources available
- Utility of automation
- Likelihood and cost of automation error
- Time and effort to program and monitor automation

- Time and effort to operate manually

Cost / Benefit

- Of change in:
 - Lateral flight path
 - Vertical flight profile
 - Takeoff runway
 - Departure route
 - Approach
 - Arrival route
 - Landing runway
 - Speed profile
 - Destination airport
- Of holding vs. diverting
- Of start/shut down of each engine
- Of level of automation
- Of evacuation

Equipment malfunctions/ Aircraft condition

- Deviation between system status and expected values
- Deviation between plan and programmed automation
- Impact of ATC degrade/outage on aircraft separation/safety
- Emergency status

Human Resources

- Confidence level in human resources
 - Flight crew
 - Self
 - Cabin attendants
 - ATC
 - Crew of other aircraft
 - Dispatch crew
 - Gate agent
 - Maintenance/ground personnel
- Areas of strength/weakness
- Workload level
- Ability to contain/calm unruly passenger(s)

LEVEL 3

Aircraft

- Projected trajectory
 - Own aircraft
 - Other aircraft
- Projected relative trajectories
- Projected separation between aircraft

Flight plan

- Projected taxi time
- Projected schedule deviation
- Estimated time of arrival
 - At destination
 - At fix
- Projected fuel requirements
- Predicted fuel usage
- Predicted fuel burn rate
- Projected time available on current fuel
- Probability of ATC granting clearance for change in flight path
- Probability of staying reliably on route
- Predicted duration of hold
- Predicted areas of congestion
- Predicted periods of congestion
- Predicted duration of delays
- Predicted time:
 - On taxi
 - To departure
 - In each phase of flight
 - To destination
 - To alternate
 - In hold
 - To next clearance
 - Aircraft can safely remain in present/anticipated conditions
 - Until maneuver required

Weather trends/forecast

- Projected hazard level
- Projected area/severity of hazardous weather encounter
- Predicted wind shear
- Predicted turbulence along route
- Predicted changes in visibility
- Estimated time for weather to lift above minimums
- Projected escape routes
- Projected impact of changes/maneuvers/weather on:
 - Safety of flight
 - Deviation from flight path

Appendix C Initial Briefing Materials

Agenda

1. Welcome / Introduction

- Purpose of study
- Roles and responsibilities
- General structure of the session: test, survey, repeat
- Legal stuff
- A word about workload
- Questions?

2. Simulator familiarization and practice

- What the simulator can and cannot do
- The en route airspace
- Special assumptions
- Questions?

3. Six test runs

- Roughly 10 minutes each
- Workload survey

4. Concluding tasks

- Summary workload survey
- Individual debrief
- Team debrief

INFORMED CONSENT STATEMENT

Research Assistant:

Todd Farley
MIT Room 35-217
77 Massachusetts Avenue
Cambridge, MA 02139

Principal Investigator:

Prof. R. John Hansman
MIT Room 33-113
77 Massachusetts Avenue
Cambridge, MA 02139

You may halt the experiment at any time and withdraw from the study for any reason without prejudice. You will remain anonymous in any report which describes this work. If you have any questions concerning the purpose, procedures, or risks associated with this experiment, please ask them.

CONSENT

In the unlikely event of physical injury resulting from participation in this research, I understand that medical treatment will be available from the MIT Medical Department, including first aid, emergency treatment and follow-up care as needed, and that my insurance carrier may be billed for the cost of such treatment. However, no compensation can be provided for medical care apart from the foregoing. I further understand that making such medical treatment available, or providing it, does not imply that such injury is the Investigator's fault. I also understand that by my participation in this study, I am not waiving any of my legal rights⁴.

I understand that I may also contact the Chairman of the Committee on the Use of Humans as Experimental Subjects, MIT 617-253-6787, if I feel I have been treated unfairly as a subject.

I volunteer to participate in this experiment which is to involve using simulator computer displays for a total of four hours. I understand that I may discontinue my participation at any time. I have been informed as to the nature of this experiment and the risks involved, and agree to participate in the experiment.

Date

Signature

⁴ Further information may be obtained by calling the Institute's Insurance and Legal Affairs Office at 617-253-2822.

PILOT BACKGROUND DATA

Position:

Current Equipment:

Type Ratings:

Total Time:

Hours in current type:

Glass Cockpit Hours:

FMS Hours:

Airline/Operator:

Age:

CONTROLLER BACKGROUND DATA

Position:

Current Facility:

Previous Facilities:

Years FPL:

Years Radar:

Years Non-Radar:

Years Supervisory:

Years Military:

Years En Route:

Age:

Appendix D Training Materials

Pilot Briefing

- ❑ The 767-200 simulator
 - ❑ Displays
 - ❑ Primary flight display
 - ❑ IAS appears to read low for the given mach
 - ❑ Map display
 - ❑ Range control (mouse)
 - ❑ Navaid declutter button (mouse)
 - ❑ Weather display
 - ❑ No tilt: Assume identical returns at all altitudes
(in other words, no opportunity to climb over or descend under the weather)
 - ❑ Seven color radar return
 - ❑ Traffic display
 - ❑ All aircraft within +/- 2600 feet of your altitude
 - ❑ Similar to current TCAS display:
Relative altitude in 100's of feet
General traffic (white "vee"), Proximate traffic (white triangle),
Traffic advisory (amber triangle), Resolution advisory (red triangle)
"Traffic, Traffic" with amber traffic advisory
Pitch command with red resolution advisory
 - ❑ Aircraft call sign in gray
 - ❑ Relative groundspeed in knots (minus indicates other aircraft is slower)
 - ❑ Mode Control Panel
 - ❑ LNAV and ALT HOLD are the initial autoflight modes for each scenario
 - ❑ Full-time autothrottle
 - ❑ Speed select
 - ❑ Flight level change
 - ❑ Heading select

- Altitude select
- Vertical speed select
- Flight directors are non-functional
- Autothrottle and autopilot paddles are non-functional
- Flight Management System (limited functionality)
 - LEGS page
 - DIR INTC page
 - Inserting waypoints
 - Going “direct”
- Side-stick controller
 - Autopilot engage/disengage switch (red button)
- Radios
 - There is no radio management
 - Assume you are automatically on the correct frequency all the time
- Push-to-talk switch (left shift key)

Pilot Briefing (cont'd.)

The flight

- Airline revenue service flight
- You are roughly mid-way through a long-haul flight
 - westbound: to LAX
 - eastbound: to JFK
 - northbound: to YYZ (Toronto)
 - southbound: to Houston
- Note: In all cases, FMS will state your destination as JFK (ignore)
- Schedule performance and ride quality matter!
- Night flight (hence the dark out-the-window view)
- All scenarios occur in the cruise phase of flight, with aircraft trimmed and autoflight systems engaged
- All scenarios traverse the same en route airspace sector belonging to INDY CENTER
- Service ceiling for today's gross weight: 40,000 feet
- Wind reports not available – assume zero wind
- Jeppesen map is provided – special provision: you and ATC are using victor airways despite being at cruise altitudes

The scenarios

- Assume you have just been handed off by the previous sector; your first call should be to establish radio contact with new Indy Center controller
- Your goal is to balance safety of flight, schedule, ride comfort, and efficiency of operation
- For purposes of this study, you will be asked to verbalize your thoughts as best you can. You do not need to narrate what you are doing. Instead, try to “think aloud” as you evaluate the situation. This will help us understand what the important factors are in your decision-making process.

❑ **Questions?**

Controller Briefing

- ❑ **The PVD simulator**
 - ❑ Sector display
 - ❑ Brightness control
 - ❑ Offset
 - ❑ Overlays
 - ❑ Weather display
 - ❑ NEXRAD: Assume identical returns at all altitudes
(in other words, no opportunity to climb over or descend under the weather)
 - ❑ Seven color radar return
 - ❑ Traffic display
 - ❑ Histories
 - ❑ Data blocks
 - ❑ PVD commands
 - ❑ Flight plan readout (QF)
 - ❑ Segmented circle (QP J)
 - ❑ Route display (QU)
 - ❑ Data block offset
 - ❑ Altitude clearance (QZ)
 - ❑ Limitations
 - ❑ No quick action keys
 - ❑ No conflict alert
 - ❑ Numerous unsupported functions (handoff, pointout, etc, etc)
 - ❑ Radios
 - ❑ There is no radio management
Assume you are automatically on the correct frequency all the time
 - ❑ Push-to-talk switch (left shift key)
- ❑ **The sector**
 - ❑ You are assigned to sector 11, Indianapolis (Indy) Center

- ❑ Sector is 14000 feet and above
- ❑ Magnetic variation is zero degrees
- ❑ Zulu time is 0200z; Temp/baro settings are ISA standard day
- ❑ Wind reports not available – assume zero wind
- ❑ Sector map is provided – special provision: you and all aircraft traversing your sector are using victor airways despite being at cruise altitudes

Controller Briefing (cont'd.)

❑ The scenarios

- ❑ You will have a few minutes prior to each scenario to survey the sector, update your flight strips, and get the general flow of the traffic
You will be expected to accept incoming aircraft (workload allowing), and verbally hand off departing aircraft to the next sector.
- ❑ If you need to coordinate with a neighboring sector, the student shadowing you will play the role of the other controller
- ❑ Flight strips are provided for your use. The flight plan information covers only the portion of each aircraft's flight before, through, and after your sector. Assume all aircraft are long-haul. (i.e., no departures or arrivals)
- ❑ For purposes of this study, you will be asked to verbalize your thoughts as best you can. You do not need to narrate what you are doing. Instead, try to "think aloud" as you evaluate the situation. This will help us understand what the important factors are in your decision-making process.

❑ Questions?

Appendix E Voice Coding Worksheet

Date:
 Session:
 Scenario:
 Coder:

General		Category													Topic														
Xactior	Xmsn	Time	Pilot	ATC	Pseudo	SpAct	Cmd	Req	Ack	Ctsy	Adv	Sugg	Inq	Ans	Int	Unc	Emb	Rep	N/C	Rte	Alt	Spd	Freq	Wx	Traf	Ride	Oth		
						1																							
						2																							
						3																							
						4																							
						5																							
						6																							
						7																							
						8																							
						9																							
						10																							
						11																							
						12																							
						13																							
						14																							
						15																							
						16																							
						17																							
						18																							
						19																							
						20																							
						21																							
						22																							
						23																							
						24																							
						25																							
						26																							
						27																							
						28																							
						29																							
						30																							
						31																							
						32																							
						33																							
						34																							
						35																							

Figure 57. Voice coding worksheet template

Appendix F NASA Task Load Index Survey Materials

Workload Rating Instructions

We are interested not only in assessing your performance but also the experiences you had during the different task conditions. Right now we are going to describe the technique that will be used to examine your experiences.

In the most general sense we are examining the "workload" you experience. Workload is a difficult concept to define precisely, but a simple one to understand generally. The factors that influence your experience of workload may come from the task itself, your feelings about your own performance, how much effort you put in, or the stress and frustration you felt. The workload contributed by different task elements may change as you get more familiar with a task, perform easier or harder versions of it, or move from one task to another. Physical components of workload are relatively easy to conceptualize and evaluate. However, the mental components of workload may be more difficult to measure.

Since workload is something experienced individually by each person, there are no effective "rulers" that can be used to estimate the workload of different activities. One way to find out about workload is to ask people to describe the feelings they experienced. Because workload may be caused by many different factors, we would like you to evaluate several of them individually rather than lumping them into a single global evaluation of overall workload. This set of six rating scales was developed for you to use in evaluating your experiences during different tasks. Please read the descriptions of the scales carefully. If you have a question about any of the scales in the table, please ask me about it. It is extremely important that they be clear to you. You may keep the descriptions with you for reference during the experiment.

After performing each task, you will be given a sheet of paper with six blank rating scales. You will evaluate the task by marking each scale at the point which matches your experience. Each line has two endpoint descriptors that describe the scale. Note that "own performance" goes from "good" on the left to "bad" on the right. This order has been confusing for some people. Please consider your responses carefully in distinguishing among the task conditions. Consider each scale individually. Your ratings will play an important role in the evaluation being conducted, thus your active participation is essential to the success of this experiment, and is greatly appreciated.

RATING SCALE DEFINITIONS	
Title	Description
MENTAL DEMAND (<i>Low/High</i>)	How much mental and perceptual activity was required (e.g., thinking, deciding, calculating, remembering, looking, searching, etc.)? Was the task easy or demanding, simple or complex, exacting or forgiving?
PHYSICAL DEMAND (<i>Low/High</i>)	How much physical activity was required (e.g., pushing, pulling, turning, controlling, activating, etc.)? Was the task easy or demanding, slow or brisk, slack or strenuous, restful or laborious?
TEMPORAL DEMAND (<i>Low/High</i>)	How much time pressure did you feel due to the rate or pace at which the tasks or task elements occurred? Was the pace slow and leisurely or rapid and frantic?
PERFORMANCE (<i>Good/Poor</i>)	How successful do you think you were in accomplishing the goals of the task? How satisfied were you with your performance in accomplishing these goals?
EFFORT (<i>Low/High</i>)	How hard did you have to work (mentally and physically) to accomplish your level of performance?
FRUSTRATION LEVEL (<i>Low/High</i>)	How insecure, discouraged, irritated, stressed and annoyed versus secure, gratified, content, relaxed and complacent did you feel during the task?

Participant No. _____

Testcase No. _____

MENTAL DEMAND



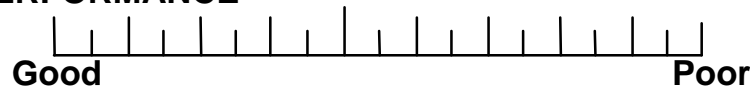
PHYSICAL DEMAND



TEMPORAL DEMAND



PERFORMANCE



EFFORT



FRUSTRATION



Workload Sources Instructions

Throughout this experiment the rating scales are used to assess your experiences in the different task conditions. Scales of this sort are extremely useful, but their utility suffers from the tendency people have to interpret them in individual ways. For example, some people feel that mental or temporal demands are the essential aspects of workload regardless of the effort they expended or the performance they achieved. Others feel that if they performed well, the workload must have been low and vice versa. Yet others feel that effort or feelings of frustration are the most important factors in workload and so on. The results of previous studies have found every conceivable pattern of values. In addition, the factors that create levels of workload differ depending on the task. For example, some tasks might be difficult because they must be completed very quickly. Others may seem easy or hard because of the intensity of mental or physical effort required. Yet others feel difficult because they cannot be performed well, no matter how much effort is expended.

The evaluation you are about to perform is a technique developed by NASA to assess the relative importance of six factors in determining how much workload you experienced. The procedure is simple: You will be presented with a series of pairs of rating scale titles (for example, Effort vs. Mental Demands) and asked to choose which of the items was more important to your experience of workload in the tasks that you just performed. Select the item that represents the more important contributor to workload for the specific tasks in this experiment.

After you have finished the entire series we will be able to use the pattern of your choices to create a weighted combination of the ratings from that task into a summary workload score. Please consider your choices carefully and make them consistent with how you used the rating scales during the particular task you were asked to evaluate. Don't think that there is any correct pattern; we are only interested in your opinions. If you have any questions, please ask them now. Thank you for your participation.

Which item in each pair was a more significant source of workload?

- Physical demand _____ Mental demand
- Effort _____ Frustration
- Temporal demand _____ Mental demand
- Performance _____ Frustration
- Temporal demand _____ Physical demand
- Performance _____ Mental demand
- Frustration _____ Physical demand
- Temporal demand _____ Performance
- Effort _____ Physical demand
- Temporal demand _____ Frustration
- Performance _____ Physical demand
- Temporal demand _____ Effort
- Frustration _____ Mental demand
- Performance _____ Effort
- Effort _____ Mental demand

