

Touch Lab Report 6

Human Haptic Discrimination of Thickness

Chih-Hao Ho and Mandayam A. Srinivasan

RLE Technical Report No. 608

December 1996

This work was supported by the National Institutes of Health under Grant NIH-5-R01-DC-00126.

**The Research Laboratory of Electronics
MASSACHUSETTS INSTITUTE OF TECHNOLOGY
CAMBRIDGE, MASSACHUSETTS 02139-4307**

Human Haptic Discrimination of Thickness

By

Chih-Hao Ho

Submitted to the Department of Mechanical Engineering
on February 15, 1996, in partial fulfillment of the
requirements for the degree of
Master of Science in Mechanical Engineering

Abstract

An experimental study was carried out to measure the human tactual ability in discriminating thickness of thin plates. Using a two-interval, two-alternative forced choice paradigm, five subjects (two males and three females) were asked to discriminate pairs of plates in which one was a reference plate and the other was a thicker comparison plate. To investigate the role of plate stiffness on the discriminability, plastic and steel plates were used. The thickness range of the reference plates was 0.25 to 10 mm for plastic and 0.05 to 0.5 mm for steel. It was found that for each material there was always a critical thickness beyond which the just noticeable difference (JNDs) remained the about same (0.4 ± 0.1 mm) for all higher values of the reference thickness. For the reference plates thinner than the critical thickness, the JNDs decreased dramatically as the reference thickness decreased. After further analyzing the plate deformation using the finite element method, it was found that under the typical forces applied by the subjects, this critical thickness represented the boundary thickness between bendable and unbendable plates. It was concluded that when the plate was effectively unbendable, kinesthetic sensation was the only cue subjects could rely on for discrimination, and the JND remained approximately the same no matter what the reference thickness was. When the plate was bendable and tactile sensation of change in plate curvature became an additional cue in the discrimination, the value of JND for thickness decreased. After calculating the curvature of the deformed plates within the region of contact, it was found that the data for both steel and plastic for all the subjects could be explained by postulating a JND for plate curvature to be about 60 ± 20 %.

Thesis Supervisor: Dr. M. A. Srinivasan

Title: Principal Research Scientist, Department of Mechanical Engineering and
Research Laboratory for Electronics

Table of Contents

Chapter 1: Introduction

- 1.1 Human Haptic System
- 1.2 Literature Review
- 1.3 Goals and Organization of the Thesis

Chapter 2: Experimental Design

- 2.1 Introduction
- 2.2 Apparatus
- 2.3 Elimination of Irrelevant Cues
- 2.4 Fabrication of Plates
- 2.5 Decision Model and Experimental Protocol

Chapter 3: Experimental Procedure

- 3.1 Training
- 3.2 Experiments

Chapter 4: Experimental Results

- 4.1 Introduction to JND
- 4.2 Experimental Results
- 4.3 Conclusions

Chapter 5: Plate Deformation - Experiments and Analysis

- 5.1 Tactual Sensing of Thickness
- 5.2 Experiments on Plate Deformation
- 5.3 The FEM Model

Chapter 6: Results of Deformation Analysis

- 6.1 Relationship between Curvature and Thickness JND
- 6.2 Curvature JND

Chapter 7: Discussion and Conclusions

- 7.1 Discussion
- 7.2 Conclusions

Appendix A: Experimental Results for Individual Subjects

Appendix B: Computation of d' and bias (β)

Appendix C: Input file for the finite element analysis of the plates using ABAQUS

Appendix D: Program for stimulus presentation using a stepper motor

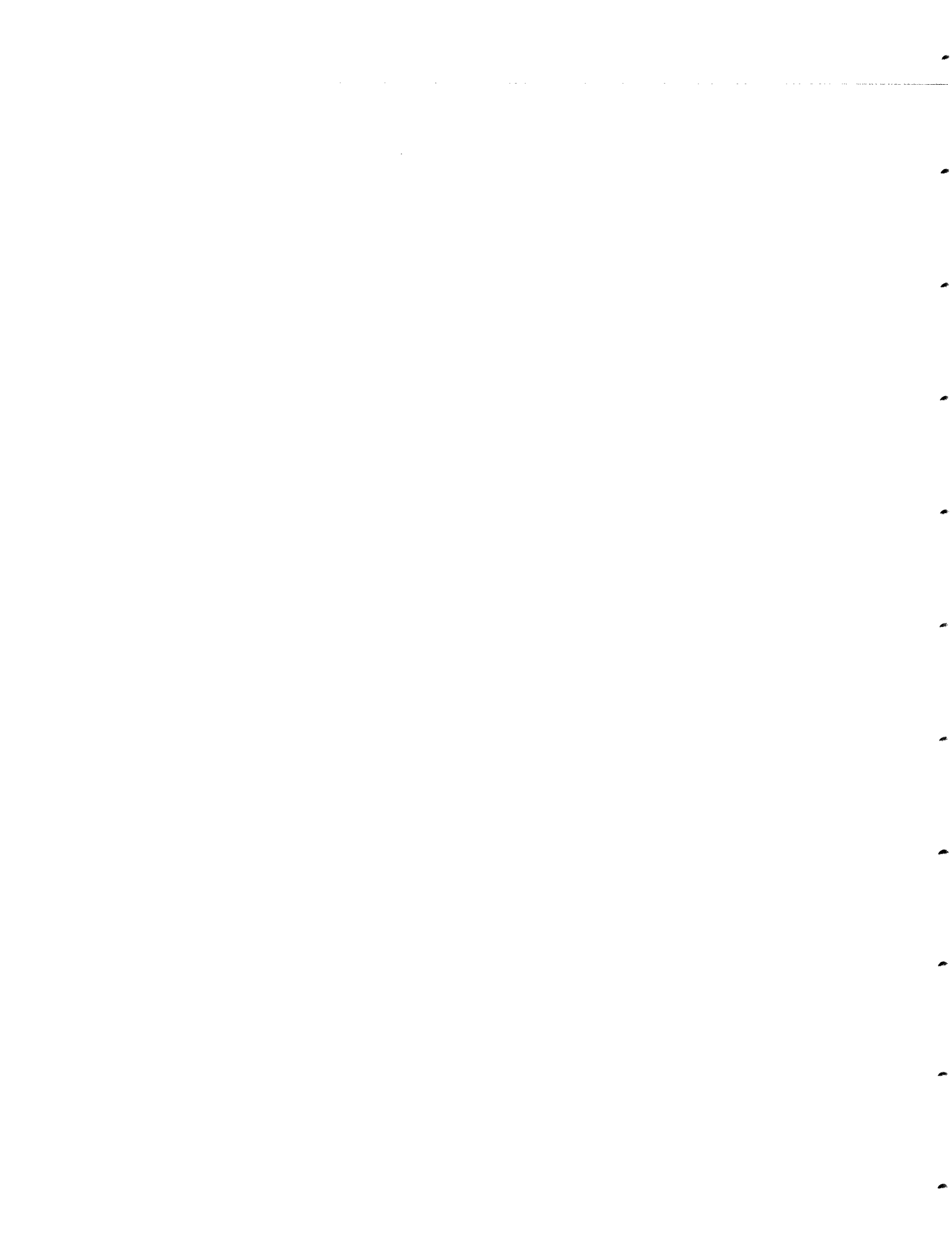

Chapter 1

Introduction

1.1 Human Haptic System

The hand is a very important organ for humans. It performs multiple functions such as sensing and operating on the environment. With these functions, we are able to reach out, explore, and manipulate the environment. It is through hands that we can produce and manipulate so many useful tools and convenient devices and shape the environment to what it is now. However, while we are enjoying these benefits that hands bring, very little is understood about their abilities: how they function and where the limits lie.

Virtual environments (VEs) are computer-generated environments which can simulate the real-world. Within these environments, humans may receive very similar sensory stimulus as they encounter in the real environment. Virtual environment is an exciting development in science and engineering, as it makes possible to train humans for some special real environments which may not be common or may have life-threatening danger. For example, the training of pilots and surgeons can be done in this environment. Thus, it can reduce the risk caused by an inexperienced practitioner and save the possible financial and

life cost accordingly.

In VE systems, the three main senses to which the interface devices display information are vision, audition, and haptic. The haptic sense is the manual sense which includes tactile, kinesthetic, and motor sensation. At present, the development of the visual and auditory VE systems is much more sophisticated than that of the haptic. The main reasons for this are a lack of understanding the basic human haptic processes and the difficulty in building haptic interfaces. Therefore, in order to establish better VE systems containing all the three sensory modalities, it is necessary to explore the world of human haptic processing. The purpose of this thesis is to investigate the roles of tactile and kinesthetic sensation in the thickness discrimination. In addition to providing a basic understanding of the abilities and mechanisms of the human haptic system, it is hoped that the results of this research will also generate useful data to support the development of better haptic interfaces for virtual environments.

1.2 Literature Review

In the studies of human tactual thickness discrimination, researchers have studied the two ends of the range of thicknesses that can be pinch-grasped between the thumb and the index finger; they have either studied on the very thin range (0.2 mm) or studied on the very thick range (10 to 80 mm). In addition, their findings on human tactual thickness discrimination abilities are mixed. For example, the study done by John et al (1989) on the human resolution of thickness of very thin plates. It was found that the subjects could

discriminate a difference in thickness of about 0.075 mm when the standard plate thickness was 0.2 mm. Three hypotheses were proposed by John et al to explain such high resolution. The first suggested that the moment of contact was sensed at the fingerpad. The corresponding joint angles at this instant would be different for different plate thicknesses and this difference was what the subjects relied on in the discrimination. The second hypothesis suggested that the joint angles employed during discrimination were the same for both plates and that it was the amount of compression experienced by the fingerpad, upon contact with the plate, that gauges the difference in thickness. The third hypothesis stated that the amount of compression of the fingerpad was the same for both plates but that the corresponding static joint angles for different plates would be different. It was this static joint angle difference that indicated the difference in plate thickness. The first and the third hypotheses imply that the thickness JND is completely governed by the joint angle JND and the second hypothesis requires to know and maintain a particular joint angle exactly. In any case, these hypotheses suggest that kinesthetic information provides the cues necessary for thickness discrimination.

In the thicker range, studies on length discrimination (10 to 80 mm) have been reported (Durlach, et al. 1989). They used the finger-span method to measure the ability of humans to discriminate object length by holding object between thumb and forefinger. It was found that subjects could discriminate a difference of about 1 mm when the standard length was 10 mm and about 2.5 mm when the standard length was 80 mm. Their results also showed that the relation between the JND and the standard length violated the Weber's law. Comparing the two studies described above, humans have much better

resolution in discriminating thin objects than in discriminating thick objects.

Although these psychophysical studies have determined the thickness resolution of the human haptic system, no explanation has been given for the large discrepancy in resolution among the two thickness ranges. The mechanism by which the thickness is discriminated is unknown and the relative roles played by the tactile and kinesthetic sensory system is not clear. In addition, no study has attempted to bridge the two ranges of thickness used by John et al (1989) and Durlach et al (1989); that is, no research has been conducted to investigate the human thickness discrimination ability for thicknesses ranging from 1 to 10 mm. The purpose of this thesis is to establish the bridging data and provide an explanation of the large difference in resolution in the two thickness ranges. Therefore, the thicknesses tested in this thesis range from 0.05 mm to 10 mm. Along with the former studies, this will provide a complete set of data on the ability of humans to discriminate thickness.

One other study has been conducted (Gajaweera et al, 1994) to investigate the roles of tactile and kinesthetic information in manual thickness discrimination. Due to limited time and lack of test plates, the study tested the human tactual thickness discrimination ability only in the 0.2 mm thickness range. According to the thesis, tactile information played an important role in manual thickness discrimination. The current study stemmed from her researches on tactual discrimination of thickness and repeated the same experiments, but in a much wider thickness range (0.05 to 10 mm).

1.3 Goals and Organization of Thesis

The goals of this thesis are (1) to measure the human tactual ability in discriminating thickness and (2) to investigate the relative contribution of tactile and kinesthetic information to thickness discriminability. Accordingly, several lines of investigation were pursued in this research. First, discrimination experiments were conducted to measure the human tactual resolution of thickness, as a function of reference thickness and material stiffness. These experiments provided data on just noticeable difference (JND) with respect to several reference thicknesses among plastic and steel plates.

The second part of the research focused on investigating the roles of tactile and kinesthetic information for different reference thicknesses. It was hypothesized that the large difference of human tactual ability in discriminating thickness in the two previous studies (John et al, 1989 and Durlach et al, 1989) arose from that different information sources were used for different range of reference thickness.

As an aid to the reader, the basic organization of the body of this thesis is described below:

In Chapter 2, the experimental design is presented. The description includes the apparatus, elimination of irrelevant cues, and fabrication of plates. The experimental protocol and decision model are also included in this chapter.

The experimental procedure is described in Chapter 3. The first half of the chapter introduces the training process. It includes the purpose of the training, the correct method

to grasp the plates, and the results of the training. The second half of the chapter describes the procedure of the formal experiments and the plate thickness tested in the experiments.

The experimental results are presented in Chapter 4. The description includes an introduction to JND, experimental results for JND, and conclusions. The results for each individual subject are given in Appendix A.

Chapter 5 and Chapter 6 describe the investigation into the role of tactile and kinesthetic information in the thickness discrimination. First, a basic introduction about tactile and kinesthetic sensation is given at the beginning of Chapter 5. The finite element method used in the deformation analysis and a calibration experiment are introduced at the second half of Chapter 5. The effect of plate curvature as the thickness JND, the relative distribution of tactile and kinesthetic information in thickness discrimination, and the results of curvature JND are presented in Chapter 6. A discussion of the results and conclusions are presented in Chapter 7.

Chapter 2

Experimental Design

2.1 Introduction

The purposes of these experiments were to measure the human tactual ability in discriminating thickness of thin plates and to identify the sensory signals that give rise to this ability. Some general questions which these experiments were designed to answer are:

- What is the just noticeable difference (JND) of human tactual thickness discrimination?
- Will the human thickness JND differ as the stiffness of the object differs?
- Does the human rely more on kinesthetic cues or tactile cues in discriminating thickness?
- Will the human reliance on the two different tactual sensory subsystems differ as a function of object thickness?

It is hypothesized that the JND of human tactual thickness discrimination will vary depending on the object material stiffness and thickness. To test this hypothesis, subjects were asked to grasp two plates of differing thickness sequentially with their index finger and thumb and to discriminate the thickness difference (Fig 2.1). To investigate the

effect of plate thickness, “reference” plates of several thicknesses were used against each of which the subjects compared the perceived thickness of several “comparison” plates. To find out the effect of material stiffness, two kinds of materials were employed in these experiments, one being plastic and the other steel.

Which Plate is thicker?

The first or the second?

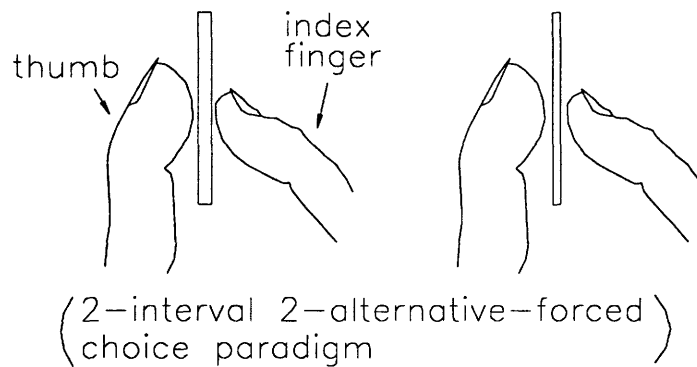

Fig 2.1 Thickness Discrimination

2.2 Apparatus

The apparatus used for running the experiments is shown schematically in Fig 2.2 (Knoedler, 1994). It consists of an eight-arm wheel holding the test plates driven by a stepper motor connected to an amplifier and a computer. The computer was used to pose on-line questions, collect data, and send out signals to the amplifier to control the stepper motor. Upon receipt of the computer signals, the amplifier was set to send an appropriate signal to drive the stepper motor. The stepper motor on receiving the signals rotated to a

preprogrammed position. In this way, any of the eight plates could be presented in any order under computer control.

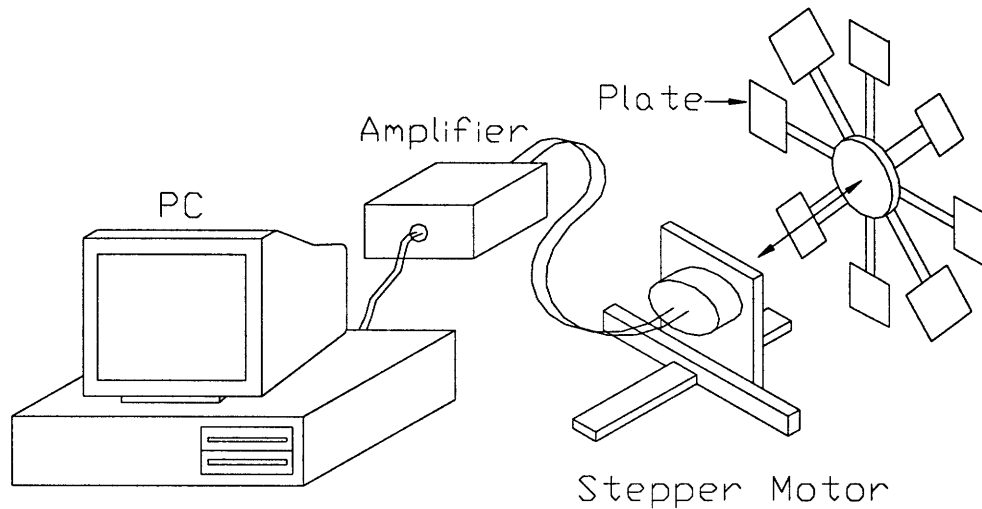

Fig 2.2 The equipment used for running the experiment

Software written in C-language governed on-screen instruction and questions, collecting the data, and automatically saving the collected data into a file. In addition, the software enabled the stepper motor to randomly present different pairs of plates one at a time. Using this setup, the subjects were able to do the experiment by themselves without the help of the experimenter.

The method of mounting the plates to the wheel is showed in Fig 2.3. The test plate is clamped between two aluminum plates (0.8 mm thick). A 1.5-inch diameter hole was made at the center of aluminum plate so that the fingers could be completely in contact with the center of the test plate without touching the frame. Two thick aluminum strips were used to attach these plates at the eight-arm wheel. The three plates were taped

together at the top to prevent separation.

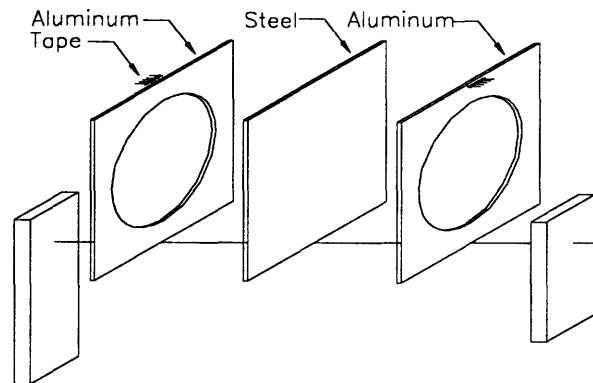

Fig 2.3 Mounting for the plates

2.3 Elimination of irrelevant cues

As the purpose of this study was to test the human ability to discrimination thickness, other irrelevant cues that might correlate with thickness were eliminated or randomized.

Possible irrelevant cues arise from the follow sources:

1. motor sound
2. visual stimulus
3. plate temperature
4. surface texture

Subjects may possibly identify the plates by the sound of the motor or the direction and time of spin. This cue was eliminated by randomly presenting the plates. The software used to control the stepper motor randomized the presentations among several plates. In this way, subjects had no way to figure out which plate was presented.

As visual stimulus may also be a cue for the subject in discriminating plate thickness, a box and a cloth screen were used to cover the stepper motor. Therefore, subjects could only rely on the sensation from their fingers to discriminate the thickness difference.

Another possible cue is the temperature of the plates. In general, thicker plates felt colder than thinner plates. Rather than an actual temperature difference in plates, this disparity is due to the difference in the heat flux out of the fingers and into the plates which is dependent on the plate thickness, thermal conductivity of the plate material, and temperature difference between fingers and plates. Hence, to eliminate the heat flux, the plate temperature was controlled at finger skin temperature. A hair dryer was used to increase the temperature in the box to approximate 88° F, roughly the same temperature as the fingertip skin surface(Fig 2.4). This temperature was decided after testing by the author -- the plates felt cold when the temperature was lower than 85° F and felt warm when the temperature was higher than 90° F. Also, the plates felt neither warm nor cold when their temperature was maintained at 88° F.

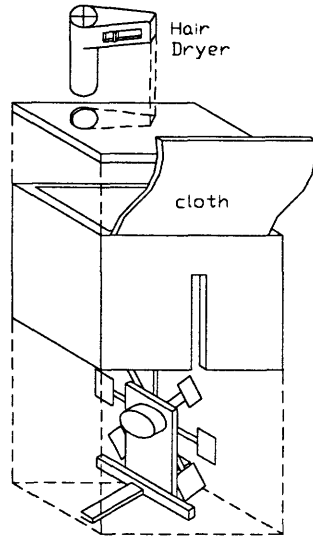

Fig 2.4 Elimination of irrelevant cues.

If the plates are not smooth enough, subjects after several trials may recognize the plates using cues arising from surface texture. Therefore, to avoid this, the plates were polished to be very smooth and kept clean. The smoothness of the plates was judged to be sufficient when the author was not able to identify them as the basis of surface texture alone.

When all these devices were combined together, the experimental environment was as shown in Fig 2.5. When performing the experiment, the subjects sat in front of the computer, used their right hand to grasp the plates and their left hand to type their response as the key board.

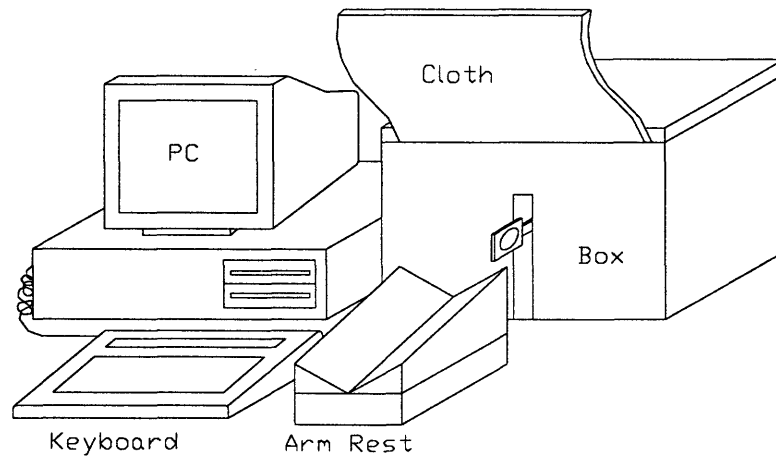

Fig 2.5 Equipment used for the experiment

2.4 Fabrication of Plates

For steel plates, the thickness range we tested was between 0.05 mm to 1.0 mm. Within this range, there are ready-made thin steel sheets available in the market with the desired thickness. Therefore, the steel plates were made by cutting them into squares of 2-inch side. The material properties of these steel plates are as follows: Young's modulus $E = 27.6$ Mpsi, Poisson's ratio $\nu = 0.305$

For plastic plates, although thin plastic sheets with desired thickness are available, they are not made of identical materials. To prevent potential bias due to surface texture and temperature cues for different materials, we decided to fabricate plates into the desired thickness, using the same material. The material we chose was plexiglas, since it is quite easy to machine it. The material properties of plexiglas are as follows: Young's modulus $E = 0.45$ Mpsi, Poisson's ratio $\nu = 0.35$.

We used end milling to fabricate the plates (Fig 2.6). In order to improve the accuracy of the plate thickness, we decided to use a computer numerical control (CNC) machine. The machine can ensure accuracy as little as 0.5 milli-inch (about 0.01 mm). As the plate smoothness was a major concern of these experiments, the plates were polished after the machining. To achieve the accuracy of the thickness of the plates after polishing, each plate was milled to one milli-inch thicker than desired. After the thickness reduction caused by the polishing, done by using a cream, the plates were measured by using a high resolution digital caliper (resolution: 0.0005 inch) to have exactly the desired thickness. After polishing, the plates still had some scratches visible on them, but were smooth enough so that human fingers could not feel the lines.

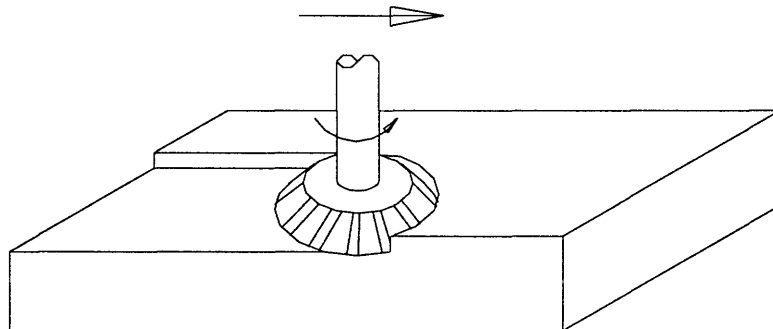

Fig 2.6 End Milling

2.5 Decision Model and Experimental Protocol

A two-interval, two-alternative-forced choice paradigm was used in the experiment. In each trial, a pair of plates were presented sequentially in which one was the reference plate and the other was the comparison plate which was always thicker. The order of which

was plate one and which was plate two was randomized. Subjects followed on-screen instructions to grasp the plates one at a time. After grasping the second plate, they were asked to key in their answer to the following on-screen question: which plate was thicker, 1 or 2. During the extensive training period prior to data collection, correct answer was shown on screen. In the actual experimentation, no correct answer feedback was given.

The experiment consisted of three parts including 3 to 4-hour training, followed by separate sessions for plastic and steel plates. With plastic plates, six sessions of experiments were conducted; in each session, four comparison plates with different thickness were presented with the reference plate. Similarly, for the steel plates, four sessions of experiments were conducted with four comparisons in each session. In both the experimental parts, each pair consisted of four runs, with each run composed of 64 trials. In this way, 256 trials form the data base for each plate pair and 1024 trials for determining the JND of each subject with respect to a particular reference plate.

Generally speaking, it took about 10 minutes to finish one run. Typically, two runs were conducted together with a short break in between. In this way, one plate pair could be completed in about an hour.

To avoid finger fatigue caused by continued touching of the plates for a long period of time, which might reduce the human tactual discrimination performance, the experimental time was always limited to no more than two hours each day.

Chapter 3

Experimental Procedure

3.1 Training

In order to make sure optimal and stable performance was achieved during each experiment session, all subjects were trained prior to actual experiments for data collection. During the training sessions, subjects were asked to discriminate the thickness of only one pair of plastic plates (10 mm and 11 mm). This pair was chosen because discriminating this thickness difference is not so difficult that it may discourage the subjects, nor is it so easy as to eliminate the challenge and dissuade the subjects from doing practices. Four parts of training were conducted to make the subjects be comfortable in the laboratory, get familiar with the experiment procedure, operate experiment equipment correctly, and optimize and stabilize their tactual performance.

In the first part of the training, the subject was asked to discriminate 10 mm and 11 mm plate without giving feedback concerning their judgment. The purpose of this training was to reduce their anxiety, let them get familiar with our experimental procedure and know how to operate the equipment correctly. First, to reduce any anxiety that might be present, subjects were given an idea of what the plate looked like by showing one example of a

mounted plate. Secondly, subjects were trained to follow the on-line step-by-step instructions to know when to grasp the plate and when to key-in their answers. Finally, subjects learned how to position their fingers and arms. The experimenter was always on the side to give demonstrations and make necessary corrections. Totally, 64 trials were run per subject in this part of training. After this session, subjects got the rhythm of plate presentation and response, so that the operational mistakes such as typing wrong inputs were almost completely eliminated.

In learning how to position their fingers, subjects were guided to correctly grasp the plates in the desired way. They were allowed to grasp only at the central area with the index finger and thumb contacting the same location on either side of the plate. As shown in fig. 3.1, case 1 shows the desired way of correctly gripping the plate, case 2, is not desired as the two fingers don't grip at the center. Case 3 is not desired either because the two fingers grasp at different locations. Subjects who used any method other than case 1 were corrected by the experimenter.

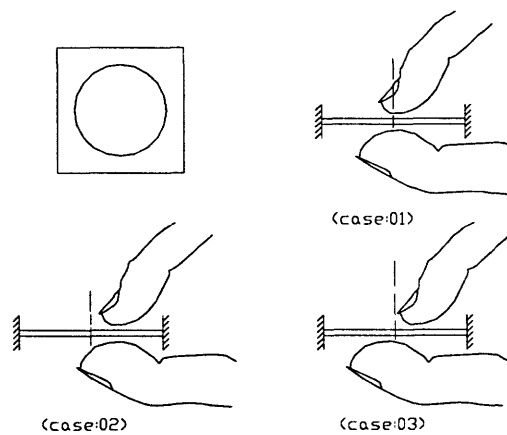

Fig 3.1 Finger positioning on the plates

The other requirement for grasping the plate was that the two fingers should apply approximately the same force. As shown in Fig 3.2, only case 1 is allowed (in case 2, index finger has applied more force, and in case 3, thumb has applied more force).

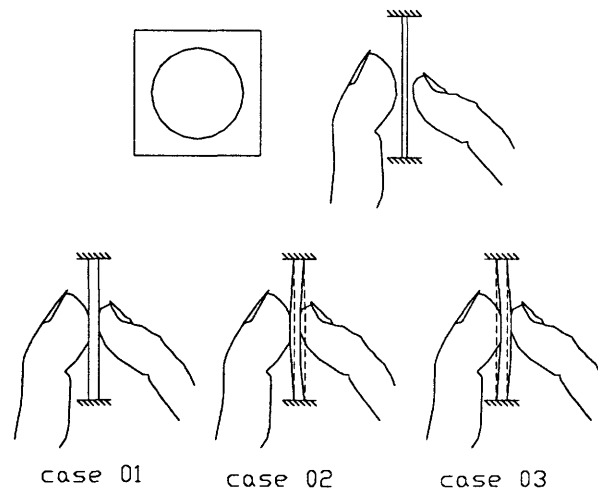

Fig 3.2 Finger gripping force

In the second part of training, subjects' initial tactual performance was measured prior to extensive practice. They were asked to discriminate the thickness of the same pair of plates--10 mm and 11 mm, over 128 trials with no correct answer feedback provided. The purpose of this part was to get their initial performance so that the experimenter could monitor how the subjects improved their performance throughout the following extensive practices.

In the third part of training, the same pair was tested with the feedback of correct answer given at the end of each pair of plate presentations. The purpose of this training was to optimize and stabilize subjects' performance. During each run of practicing, subjects had to complete 64 trials. If their performance was not stable, they would be asked to practice

another run of trials until stabilization occurred. In addition, during this session, we encouraged subjects to try different ways of grasping the plates (without violating the constraints depicted in Fig 3.1. and 3.2) to find a best way for themselves. For example, some subjects preferred applying large forces and some subjects preferred using finger postures that resulted in larger contact areas. Because the correct answer feedback was given, subjects could know the effect of each method on their performance right after each trial. In this way, it would be easy for them to find the best way of grasping the plates and therefore, optimize their performance. In this part of training, subjects were asked to practice for 256 trials first. If their performance curve was not steady, they were asked to continue practicing until their performance stabilized.

In the fourth part of training, the same pair was tested with no correct answer feedback provided. The goal of this part was to measure subjects' tactual performance after extensive practice. Our intention was to see if subjects performed better compared with their own initial performance as measured in part two. Fig. 3.3 shows the curve of subjects' performance as training progressed. We can see from Fig 3.3, the performance of the subjects did improve significantly over time and stabilization occurred after about 6 blocks of 64 trials each.

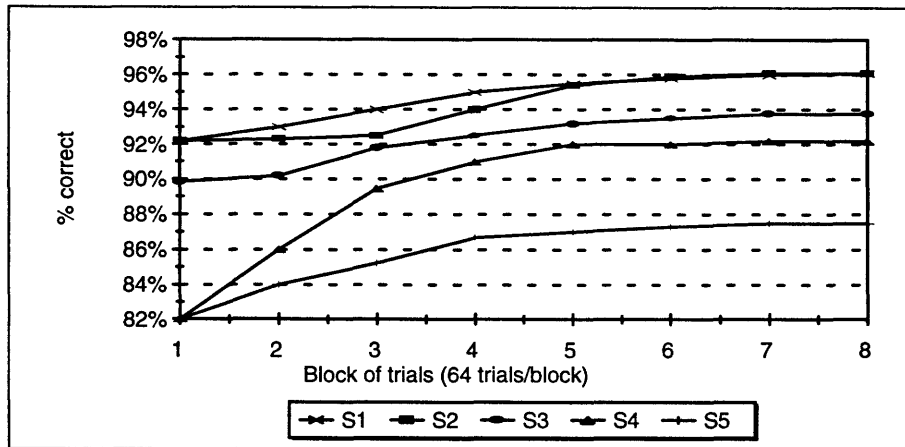

Fig 3.3 The result during training process (with feedback)
 #1 is the initial performance (no feedback, 128 trials)
 #8 is the final performance (no feedback, 128 trials)

On average, subjects took about 3 to 4 hours for the whole training process and practiced for more than 500 trials. After all the four sessions of training, subjects were able to perform the experiment in the desired method and with a stable performance.

3.2 Experiments

The tested thickness of the reference plates are shown in Fig 3.4. For plastic plates, the reference thicknesses tested were 10.0 mm, 5.0 mm, 2.5 mm, 1.0 mm, 0.5 mm, and 0.25 mm. For steel plates, the thicknesses were 0.5 mm, 0.25 mm, 0.1 mm, and 0.05 mm.

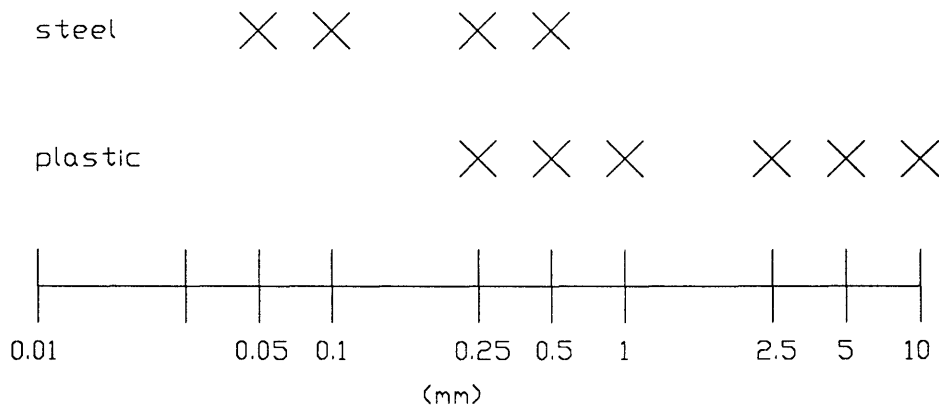

Fig 3.4 The thickness of reference plates used in the experiment

For each of the reference thickness in either material, four comparison plates were made. Those comparison plates were always thicker than the corresponding reference plate. The subject was asked, one pair at a time presented sequentially, to discriminate the thickness difference between the reference plate and the comparison plates. In the experiments, the subjects were always first exposed to the pair with largest thickness difference, then to the pair with second largest thickness difference, and so on. That is, the difficulty of discriminating thickness gradually increased. In this way, subjects could adjust themselves for finer thickness discriminations through out the experimental sessions without extra training. The subjects, however, were not informed of this order of sessions.

The formal experiment comprised of ten sessions, six for the plastic plates and four for the steel plates, with four runs of paired thickness discriminations in each session. The sessions for the plastic plates were followed by those for the steel plates. The order of sessions for the same material was determined by the thickness of the reference plate, beginning with the thickest reference plates and moving on to the next smaller reference thickness. For example, in the sessions for the plastic plates, we began with the

reference plate of 10.0 mm, went on to 5.0 mm, 2.5 mm, 1.0 mm, 0.5 mm and 0.25 mm. Similarly, in the sessions for steel plates, we began with the 0.5 mm thick reference plate and ended with 0.05 mm reference thickness. Table 3.1 shows the exact order of all the sessions and the paired thickness discriminations in each session. The thickness of reference plates, their corresponding comparison plates, and the percentage difference for the pairs are also indicated in the table.

Table 3.1 Thickness table of reference plates and comparison plates in the experiments

Session / Material	Reference Plate Thickness	Comparison Plate Thickness / Thickness Difference Percentage			
		Part 1	Part 2	Part 3	Part 4
1 Plastic	10.0 mm	11.50 mm 11.5%	11.00 mm 10%	10.50 mm 5%	10.25 mm 2.5%
2 Plastic	5.0 mm	6.00 mm 20%	5.75 mm 15%	5.50 mm 10%	5.25 mm 5%
3 Plastic	2.5 mm	3.50 mm 40%	3.25 mm 30%	3.00 mm 20%	2.75 mm 10%
4 Plastic	1.0 mm	1.85 mm 85%	1.70 mm 70%	1.50 mm 50%	1.30 mm 30%
5 Plastic	0.5 mm	1.30 mm 160%	1.00 mm 100%	0.75 mm 50%	0.65 mm 30%
6 Plastic	0.25 mm	0.60 mm 140%	0.50 mm 100%	0.35 mm 40%	0.30 mm 20%
7 Steel	0.5 mm	1.28 mm 155%	1.00 mm 100%	0.90 mm 80%	0.78 mm 55%
8 Steel	0.25 mm	0.90 mm 260%	0.78 mm 210%	0.625 mm 150%	0.50 mm 100%
9 Steel	0.1 mm	0.625 mm 525%	0.5 mm 400%	0.375 mm 275%	0.25 mm 150%
10 Steel	0.05 mm	0.25 mm 400%	0.20 mm 300%	0.10 mm 100%	0.075 mm 50%

When running the formal experiments, no correct answer feedback was given. In each part of paired thickness discrimination, four runs were conducted. One run consisted of 64 trials and took about ten minutes. Typically, there was a short break between two runs. In this way, conducting one part of experiment usually took one hour. Our data base per part contained 256 trials.

The experimental time for each day was limited to no more than two hours to avoid finger fatigue. To make sure stable performance was achieved, subjects were always asked to practice for at least five minutes before their data was collected each time they performed the experiment.

Chapter 4

Experimental Results

4.1 Introduction to JND

In psychophysics, the confusion matrix is often used to record results for a two-alternative forced choice (2-AFC) experiment. A confusion matrix looks like Fig 4.1.

	R1	R2
S1	f11	f12
S2	f21	f22

Fig 4.1 Example of a Confusion Matrix
for 2-Alternative Forced Choice(2-AFC) experiment

The confusion matrix is composed of signals and responses: it records the frequency of subjects' responses as related to the signals presented. In a 2-AFC experiment, as is the case in our experiments, there are two admissible signals - S1 and S2 (either the plate one is thicker or the plate two is thicker) and two possible responses R1 and R2 (subjects may answer that the plate one is thicker or the plate two is thicker). In each cell of the confusion matrix, the frequency of the response for each signal is recorded. The "f11" stands for the response frequency of receiving S1 signal and giving R1 response.

In other words, for the S1 signal plate one is thicker and the subject responds correctly by answering that plate one is thicker. The “f12” means for the signal that plate one is thicker, the subject judges erroneously that plate two is thicker. In the matrix, “f11” and “f22” indicate the frequency of correct responses and “f12” and “f21”, the wrong responses.

Using this confusion matrix, we can calculate the sensitivity index (d' or d_{prime}) and bias (β) based on signal detection theory and a decision model (Appendix B). When more correct responses are given, the calculated d_{prime} will be larger. On the other hand, if the subject gives a lot of wrong responses, the d_{prime} will be very small. The following are confusion matrix examples and the corresponding d_{prime} values.

		R1	R2
S1	50	0	
S2	0	50	

$d_{\text{prime}} = \text{infinite}$

		R1	R2
S1	40	10	
S2	10	40	

$d_{\text{prime}} = 1.68$

		R1	R2
S1	25	25	
S2	25	25	

$d_{\text{prime}} = 0$

As in each of our experimental sessions, four pairs of thicknesses were discriminated for each reference plate, four confusion matrices were thus produced. For each confusion matrix, we can calculate the corresponding d_{prime} value. Using the d_{prime} values, we may compute the JND (just noticeable difference), which is defined as the thickness difference corresponding to $d_{\text{prime}} = 1$ for an one-interval experiment (Appendix A). Or in other words, JND is the thickness difference for which subject gives 70% correct responses in the absence of response bias.

Table 4.1 gives as an example the results corresponding to the 10 mm plastic plate as the reference for subject 1 and the calculated dprime value and bias. As our experiments were 2-interval experiments, the values of dprime should be revised by divided by square root of 2. The values of dprime in the table are the results that have already been divided by square root of 2 (the reason of this revision is given in Appendix A).

Table 4.1 Experimental results for subject one (2-interval 2-AFC)
Reference plate thickness = 10 mm

Thickness		0.25 mm		0.5 mm		1.0 mm		1.5 mm	
Difference		2.5 %		5 %		10 %		15 %	
		R1	R2	R1	R2	R1	R2	R1	R2
Total	S1	76	37	105	23	122	6	127	1
Result	S2	42	86	36	92	7	121	1	127
dprime (d')		0.63		1.06		2.32		3.76	
bias (β)		0.01		0.17		0.04		0.0	

From this table we can see the dprime is different for the four thickness pairs. When the thickness difference is large, the dprime value tends to be large, since the pair is easy to discriminate and the subject gives more correct responses. The bias represents the tendency of the subject to choose a certain response. A positive value of bias means the subject has a tendency to respond that plate one is thicker more number of times than responding that plate two is thicker. Based on Table 4.1, we can draw a graph relating thickness difference to dprime. The graph is shown in Fig 4.2.

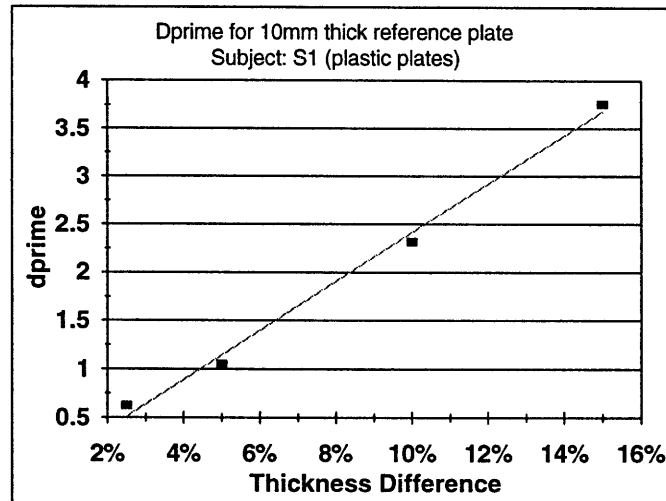

Fig 4.2 graph of dprime vs. thickness difference

From the graph, it can be observed that the relation between the dprime and the thickness difference is linear. By definition, the JND is the thickness difference corresponding to $d_{\text{prime}} = 1$ and represents a quantitative measure of the subjects' resolution. In our case, since there are four pairs of dprime and thickness difference for each reference thickness, the JND is defined to be the average value of the ratio thickness difference divided by its corresponding dprime for the four pairs. Therefore, the JND for this subject is about 4.2% for the 10 mm reference thickness. What is the meaning of this JND? It means that if we ask the subject to discriminate between 10.0 mm and 10.42 mm, the subject's responses will be about 70% correct (50% represents pure guessing and 100% represents full discrimination). If we calculate the confusion matrix for discriminating this thickness difference, the dprime should be around 1.

The experimental results below are obtained by applying the same methodology as mentioned above.

4.2 Experimental Results

A total of five subjects participated the experiments. For simplicity, they are indicated as S1(female), S2(male), S3(male), S4(female), and S5(female). All the five subjects were right hand dominant. The same experiments were run on all the five subjects. The experimental results of confusion matrix, dprime, bias, and JND for individual subjects are given in Appendix A. Fig 4.3 to Fig 4.7 show the graphs relating the reference thickness to JND calculated as a percentage of the reference thickness for all the five subjects.

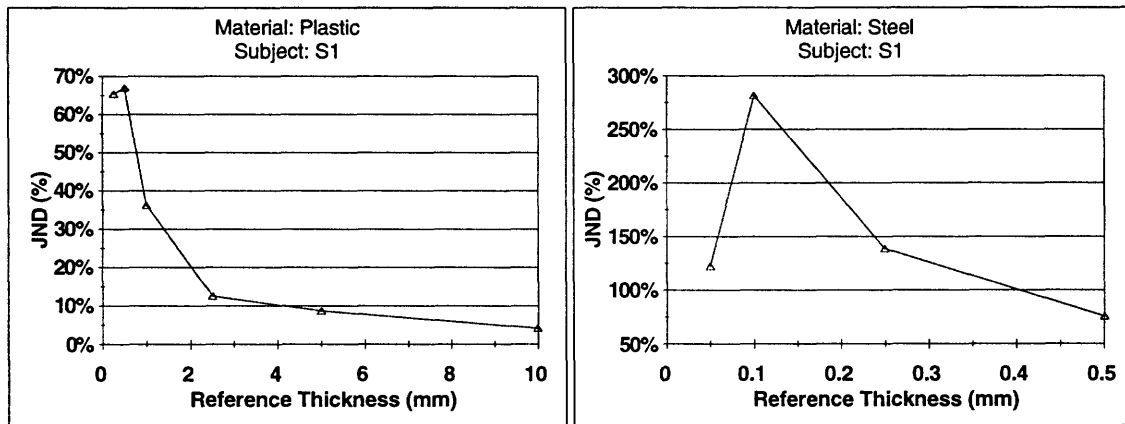

Fig 4.3 JND(%) vs. Reference Thickness for Subject S1

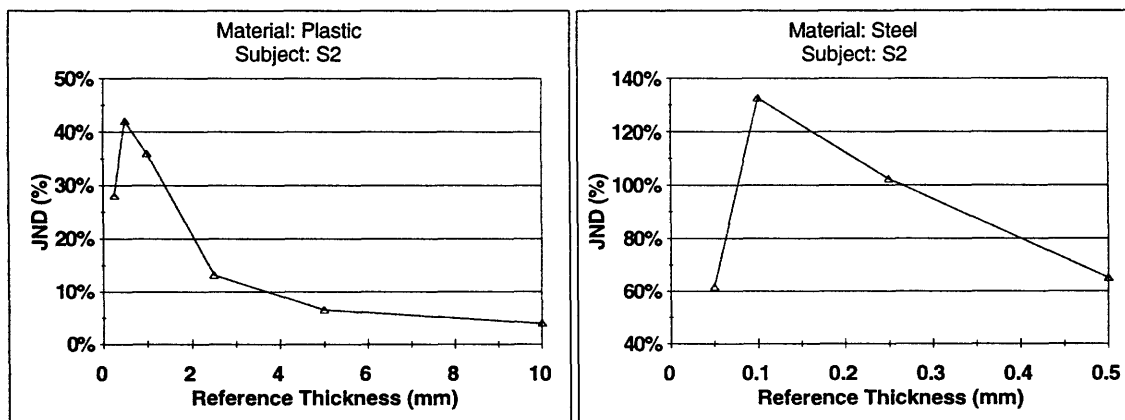

Fig 4.4 JND(%) vs. Reference Thickness for Subject S2

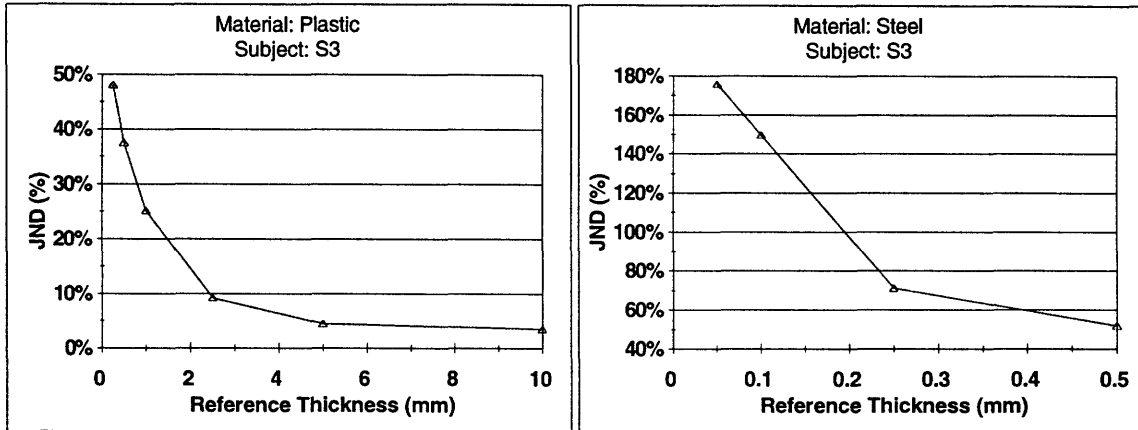

Fig 4.5 JND(%) vs. Reference Thickness for Subject S3

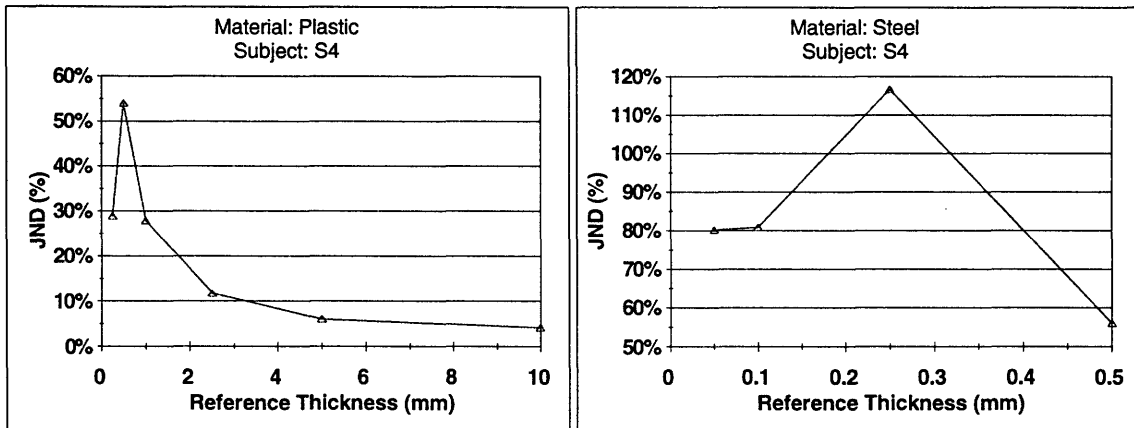

Fig 4.6 JND(%) vs. Reference Thickness for Subject S4

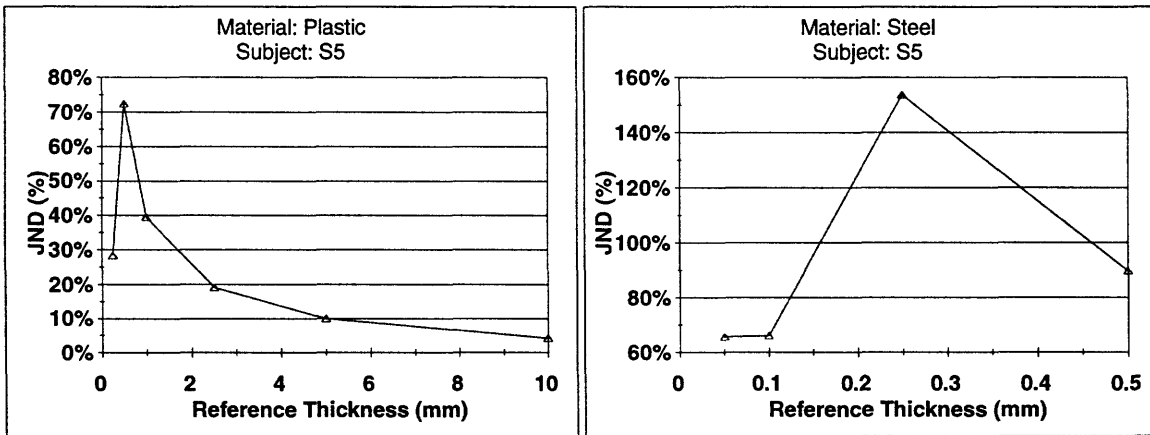

Fig 4.7 JND(%) vs. Reference Thickness for Subject S5

The above graphs show that the subjects' performance does not follow the Weber's law,

which states that the percentage JND will remain constant and independent of the reference thickness. Instead, as the reference thickness reduces, the values of % JND always increase first and then decrease except for only one subject (S3) whose % JNDs keep increasing when the reference thickness decreased for all the values tested. This phenomenon is true for both plastic and steel plates. For most of the subjects, it appears that the maximum value of JND occurs at 0.5 mm for plastic plates and between 0.1 and 0.25 mm for steel plates.

Another way to look at the resolution of subjects' ability is to use the absolute value of thickness JND, which can be converted from the percentage JND. For example, if the JND for 10.0 mm reference thickness is 4.2%, the converted absolute value of this JND is 0.42 mm. Fig. 4.8 to Fig 4.12 show the graphs of the relation between different reference thickness and their respective JND in absolute thickness values for all the five subjects.

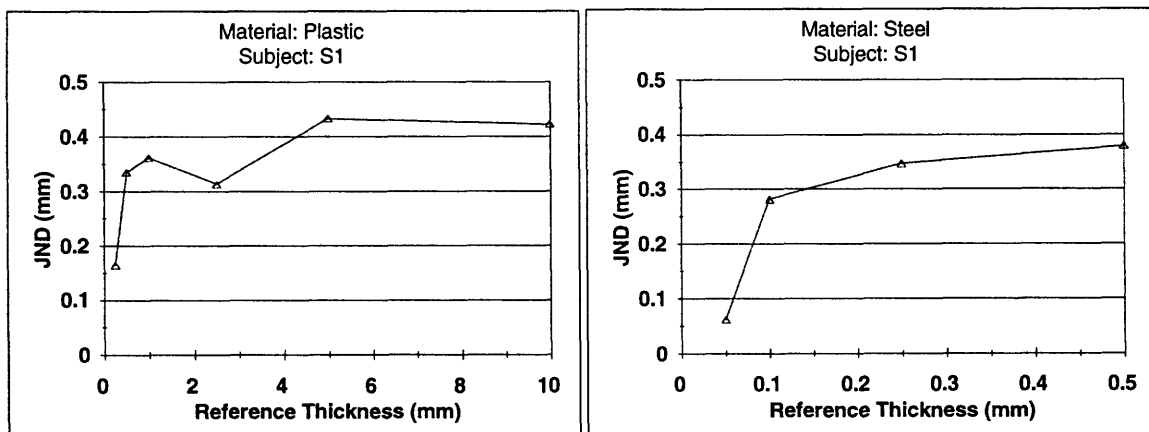

Fig 4.8 JND(mm) vs. Reference Thickness for Subject S1

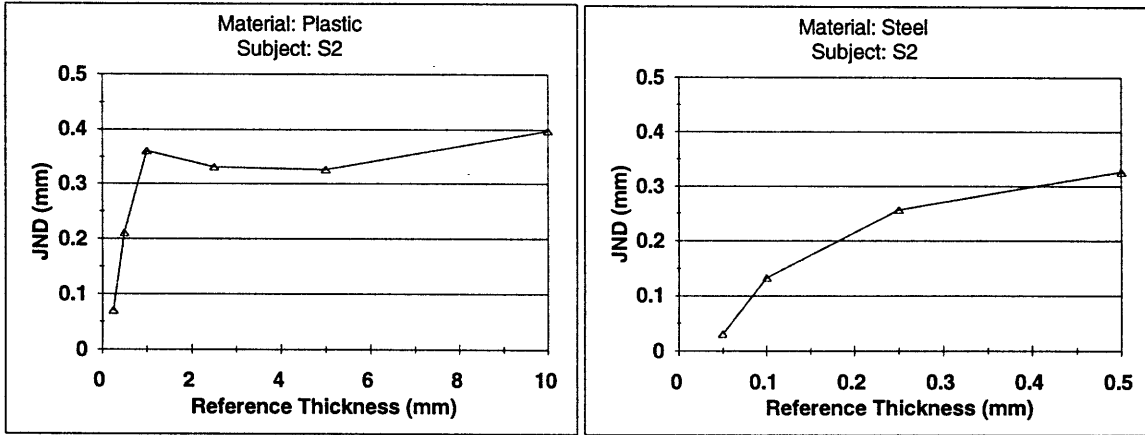

Fig 4.9 JND(mm) vs. Reference Thickness for Subject S2

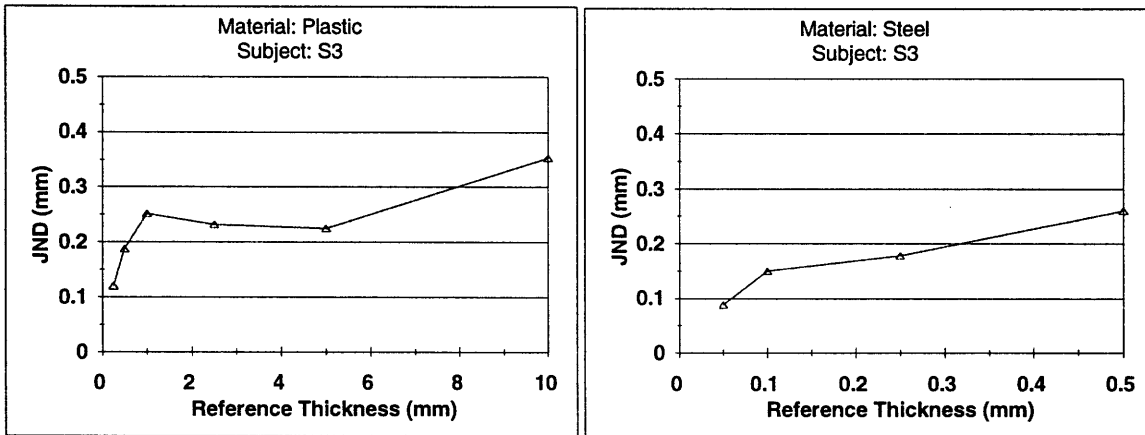

Fig 4.10 JND(mm) vs. Reference Thickness for Subject S3

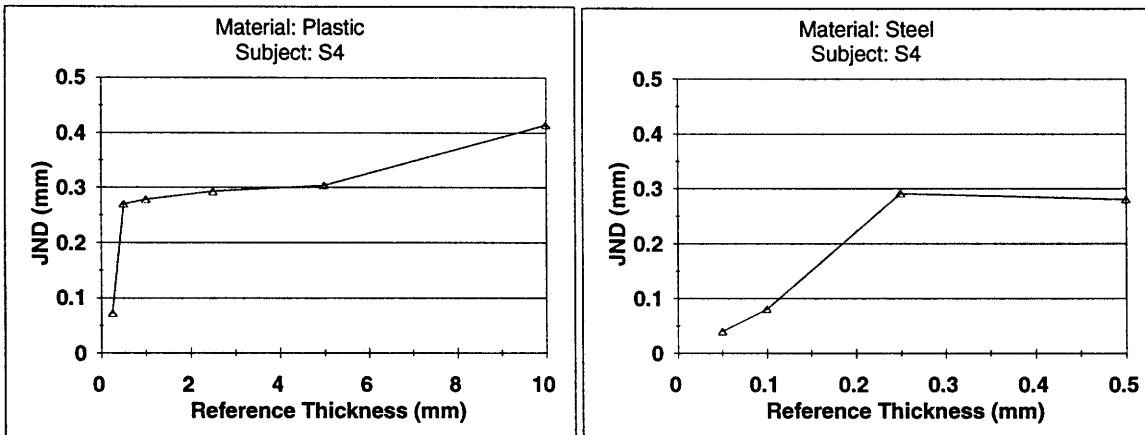

Fig 4.11 JND(mm) vs. Reference Thickness for Subject S4

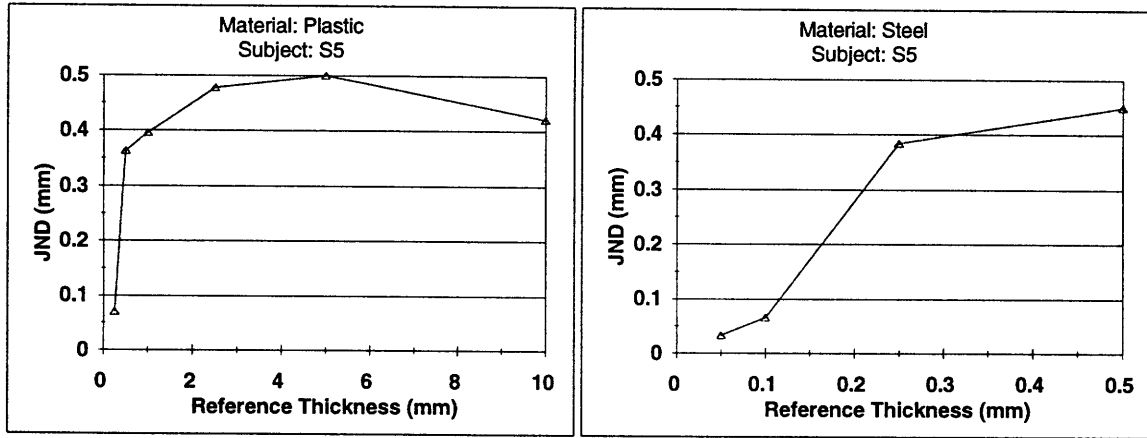

Fig 4.12 JND(mm) vs. Reference Thickness for Subject S5

Comparing the above five graphs, we can see that the JND curves for each material have almost the same shape: as the reference plate thickness reduces the JNDs remain approximately the same value first and then decrease. In other words, the subjects' JNDs maintain approximately the same value when the plates are not too thin. However, their JNDs decrease dramatically when the plates are very thin. It is likely that there exists a critical value of plate thickness where this changeover occurs. If the plates are thicker than the critical value, the subject's JND appears to be approximately the same no matter how thick the plate is. On the contrary, if the thickness of the plate is below the critical value, the JND appears to decrease as the plate thickness reduces, which means the subject's discrimination ability increases.

When the plate thickness is larger than the critical thickness, the values of JND all lie between 0.25 mm and 0.5 mm for the five subjects, and this is true for both plastic and steel plates. Comparing the subjects' performance in the thick reference plate range, the JND values of subject S3 were the smallest among the five subjects. It means that this subject has a sharper sense in discriminating thickness when the reference plate is in the

thicker range. When the reference plates were very thin, thickness resolution of all the five subjects improved dramatically. Some subjects could even discriminate a thickness difference as small as 0.03 mm.

4.3 Conclusions

Based on the discrimination performance of all the five subjects, we can draw the following conclusions.

- For each subject, there appears to be a critical thickness for each material: when the plate thickness is larger than the critical thickness, the subject's JNDs remain constant and independent of the reference thickness; when the plate is thinner than the critical thickness, the JNDs decrease as the reference thickness decreases. This result is consistent across all subjects.
- Although the critical thickness differs for each subject, the difference is negligibly small. In fact, for all subjects, the critical thicknesses lie between 0.5 mm to 1.0 mm for plastic plates and between 0.1 mm to 0.25 mm for steel plates.
- For reference thicknesses larger than the critical thickness, the subjects' JNDs are in the range of 0.3 mm and 0.5 mm, except for one subject (S3) whose JND was 0.25 mm.

Chapter 5

Plate Deformation - Experiments and Analysis

5.1 Tactual Sensing of Thickness

When using fingers for thickness discrimination, the tactual sensory system provides the necessary information. Tactual information consists of two parts: kinesthetic and tactile (Loomis et al, 1986). Kinesthetic information provides the sense of position and motion of fingers which comes from sensors in the finger joints, skin around the joints, tendons, muscles, etc. Tactile information provides the sense of contact with the object which is mediated by the mechanoreceptors in the skin, e.g., the fingerpad. Tactile sensation enables the detection and discrimination of surface textures, small shapes, softness, etc. (Srinivasan et al, 1990, 1991,1995) The difference between these two sensory sources is illustrated in Fig 5.1.

When subjects grasp a plate, the joint angles of the fingers will depend on the thickness of the plate. The information obtained from changed joint angles in discriminating two plates of different thickness can therefore be completely based on kinesthetic information. However, when the plates are very thin and bendable, it is likely that they will be deformed due to the grasp force. For a given applied force, the amount of bending depends on the

thickness of the plate and the stiffness of the material of the plate. To discriminate the two plates, subjects may therefore rely on tactile sensation that arises from the skin of the fingerpad, and base their judgments on the shape of the deformed plates.

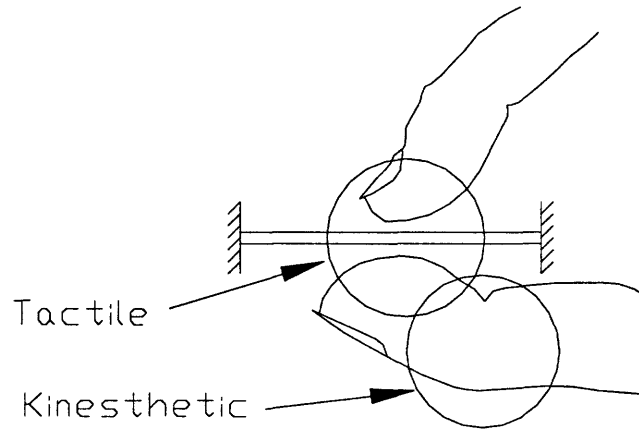

Fig 5.1 Tactile and Kinesthetic Sensory sources

In the experimental findings discussed in chapter 4, when the plate was thicker than the critical thickness, the JND was about the same no matter what the reference thickness was. On the other hand, when the plate was thin or below the critical thickness, the JND decreased. One possible explanation of this change in JND value is that if the plate thickness is below the critical value, it is likely that it is bendable.

When two plates being discriminated are both thick and unbendable, tactile information is the same for both (assuming there are no surface texture or the temperature differences) and only the kinesthetic information can be different for the two plates (Fig 5.2). The tactual sensory abilities are therefore governed by the kinesthetic cues available to the subjects. That is, the smallest thickness difference that subjects can resolve is determined

by the resolution limit of kinesthetic sensation, irrespective of the different reference thicknesses used in the experiment. This explains why the JND value remains approximately the same when the plates are thick.

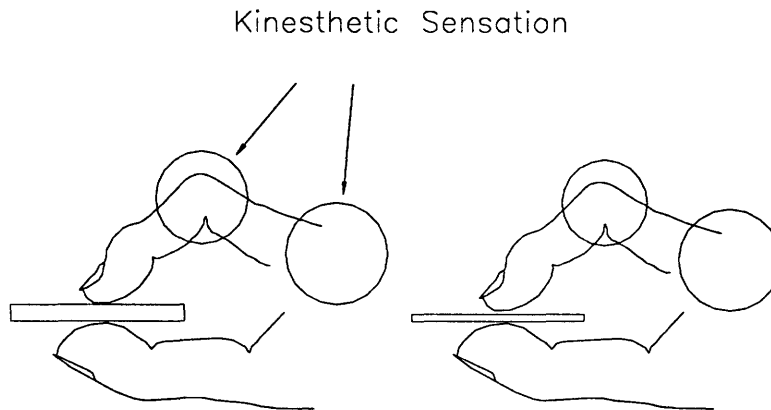

Fig 5.2 Kinesthetic Sensation

As observed in the experimental findings, when the plate was thinner than the critical thickness and bendable, the JND value drops dramatically. An explanation is that in this range of thickness, the amount of bending is different for the two plates causing tactile cues that enable subjects to discriminate much smaller thickness difference than kinesthetic cues. Fig 5.3 shows the deformed plate and how the tactile sensation is obtained. It is to be noted that subjects are trained to apply the same force with each finger in grasping the plate, but the contact areas of the two fingers differ causing the plate to deform.

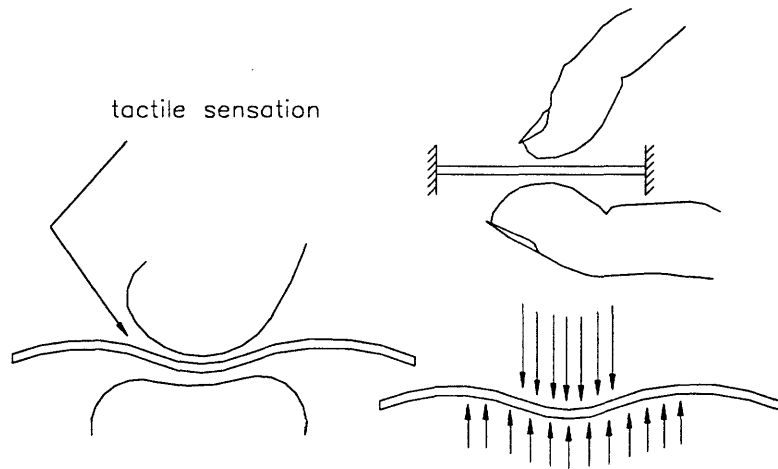

Fig 5.3 Tactile Sensation

In order to investigate the relationship between the JND and tactile information, the deformation of the plates is analyzed below.

5.2 Experiments on Plate Deformation

Because of the way each plate is mounted and the corresponding complexity in the boundary conditions (Fig. 5.4), it is not possible to accurately calculate the deflection of the plate by analytical means. The only possible way is to use a numerical procedure to analyze the plate deformation. Hence, the following finite element method analysis was used to calculate the deflection of the plate under pinch grasp between the thumb and index finger.

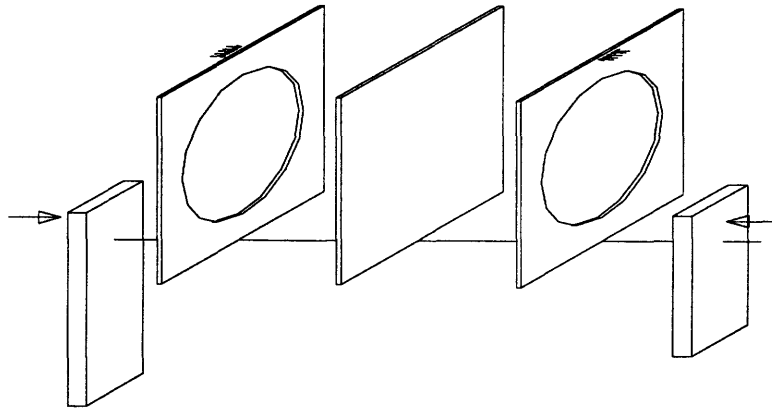

Fig 5.4 The plate shape and its boundary condition.

A very important prerequisite in using the finite element method (FEM) is to ensure that the model realistically represents the plate. In order to ensure the correctness of FEM analysis, an experiment was designed.

The underlying idea in proving the FEM analysis to be correct was to check if the surface strains predicted by the FEM were the same as those measured experimentally, under controlled loading. The reason for choosing strain as the comparison variable is that it is possible to measure it quite accurately using strain gages bonded to the plate.

In analyzing the plate deformation, there are two possible models that can be used in the FEM. One, an easier one, is to model the plate as a flat shell. The other is to model it as a three-dimensional solid. If we can prove that the shell model is good enough based on strain measurements, then we don't need to use the complicated three-dimensional model. On the contrary, if the outcome of shell model does not match the experimentally measured strains to sufficient accuracy, the 3-D model analysis needs to be performed.

In the experiments, three plates were chosen as our verifying plates. All of them were steel plates with thicknesses of 0.05 mm, 0.1 mm, and 0.25 mm respectively. Four strain gages were attached to each of them (Fig. 5.5). The attached four strain gages formed a Wheatstone Bridge, as shown in Fig. 5.6, which allowed us to measure the surface strains of the plate at the corresponding locations.

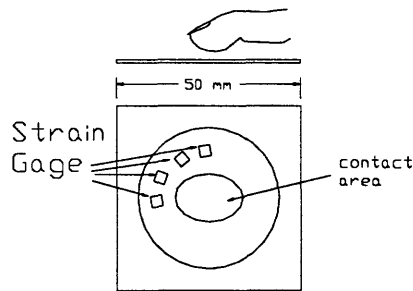

Fig 5.5 Strain Gages

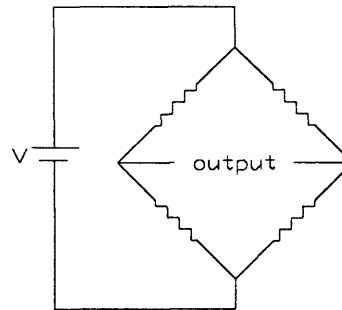

Fig 5.6 Wheatstone Bridge

The force applied by subjects' fingers on the plate was measured by using a thin force sensor (0.076 mm thick, UniForce Sensor , by Force Imaging Technologies). (Fig. 5.7) The UniForce sensor is made of a special material whose resistance decreases as the force applied. With the strain gages and the UniForce sensor attached on the plate, we were able to measure both the applied forces and plate strains at the same time when the finger touched the plate.

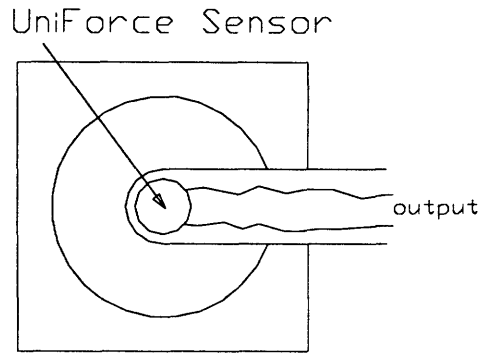

Fig 5.7 UniForce sensor

In experiments where the index finger was used to press on the plate, a linear relationship between the applied force and plate strain was found, as shown in Fig. 5.8. In addition, the results show that the slope of the line, representing the relationship between the force and the strain, changes as plate thickness differs. Fig 5.9 shows the three graphs superimposed. The ratios of the slopes for the three lines is 1:0.67:0.37. Therefore, in order to verify the FEM analysis and to decide which of the two models are to be used, the analysis should predict the same characteristics as the experimental results: the linear relationship between the strain and the applied force and the same ratios between the slopes for the three different plate thicknesses.

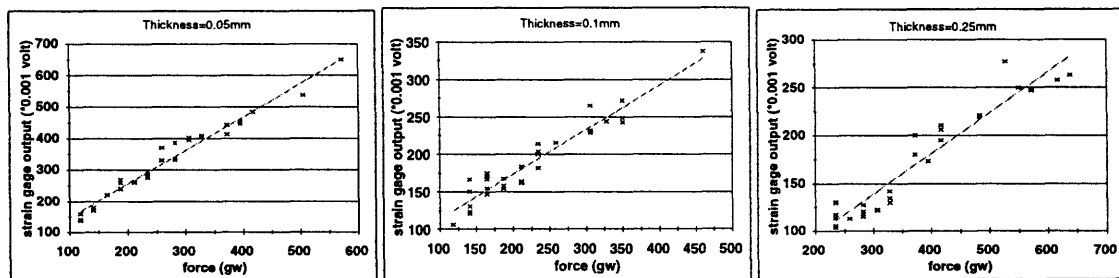

Fig 5.8 Relationship between applied Force and Strain Gage Output

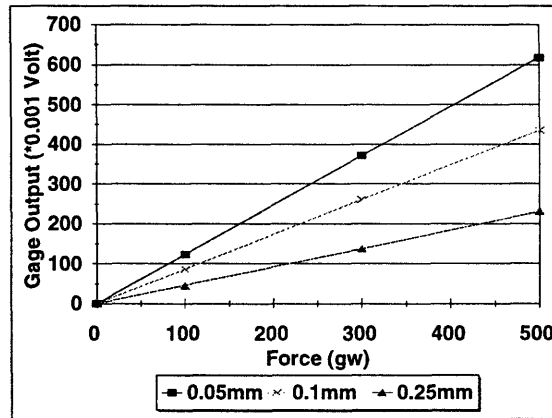

Fig 5.9 Relationship between applied Force and Strain Gage Output for the three plates

5.3 The FEM model

To perform the FEM analysis, two pieces of information, the applied force and contact area, are required. The applied force can be easily measured by using the UniForce sensor as discussed in the previous section. For measuring the contact area, no simple and accurate method exists. One possible way is to measure area covered by the fingerprint pattern on the plate. To measure the maximum contact area, subjects' fingers were inked before they touched the plate, and the fingerprints on the plate were measured at the end of a trial.

Based on the fingerprints recorded from several subjects, it was found that the shapes of the fingerprints were similar to ellipses, with the length of major and minor axes being 4:3. Therefore, to measure the area, various ellipses of same eccentricity and representing different areas with the same center were drawn on a transparent sheet (Fig 5.10). The area covered by the ellipses ranged from 100 mm² to 1000 mm², with a step size of 50

mm² between 100 mm² and 400 mm², and a step size of 100 mm² between 400 mm² to 1000 mm².

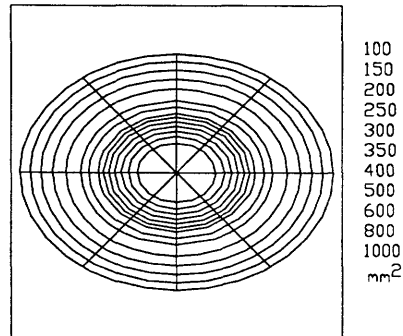

Fig 5.10 Ellipses for measuring fingerprints

The area of each fingerprint was measured using a microscope by overlaying the ellipses on the fingerprint on the plate. Although the data from this measurement is not very accurate, it is good enough because the contact area had minimal effects on the FEM outcome. Only the force applied has major effect in influencing the FEM output. For example, for a force of 300 gw, the difference between calculated strains for contact areas equal to 200 mm² and 250 mm² respectively is only 9%. Hence, if the error of measuring the area is 10 mm², the estimated error in strains is only 2%.

Based on the experiments that showed linear relationship between applied force and measured strain, the following assumptions were made in calculating the curvature of the deformed plates:

- The finger touches the plate right at the center.
- The force is uniformly distributed throughout the contact area.
- The plate material is homogeneous, isotropic, and linearly elastic.

- The plate deformation is infinitesimal.

We used the “ABAQUS” FEM software package. Two different element types were used in modeling the plate. One was a shell element with eight nodes and five degrees of freedom. The other was a three-dimensional element with eight nodes and six degrees of freedom. The 3-D model contained three layers of elements and the load was assumed to be uniformly distributed pressure within the contact region. The boundary conditions were imposed by fixing the nodes at one end (corresponding to the mounting shown in Fig5.11) and letting the other end to be free. At the free end of the plates, a tape was used to avoid the separation of the plates by shearing. To simulate this condition in FEM analysis, the motion of the plates was constrained so that the plates could not slip relative to each other.

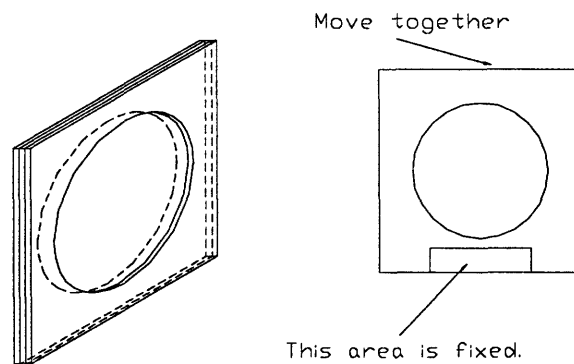

Fig 5.11 3-D Model for FEM

In calculating the strains, we used three different plates, same as that used in the experiments-- 0.05 mm, 0.1 mm, and 0.25 mm thick. The applied forces was set to be 100 gw, 300 gw, and 500 gw, whereas, the contact area was set to be 200 mm², the typical

contact area measured for the index finger. (As observed earlier the contact area only affects our result very little.) Using ABAQUS the deflection and the strain for each node were calculated. Fig 5.12 shows the graph of the relation between force and strain for the shell model. Fig 5.13 shows the graph of the relationship between the two for the 3-D Model.

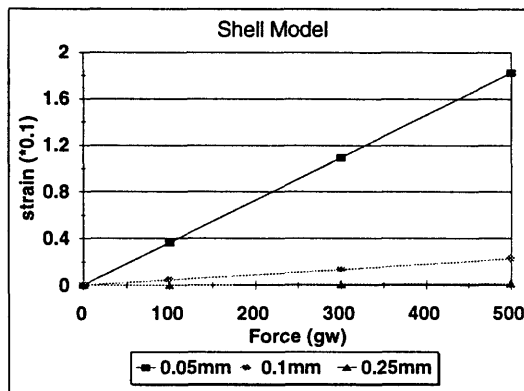

Fig 5.12 Strain vs. Force

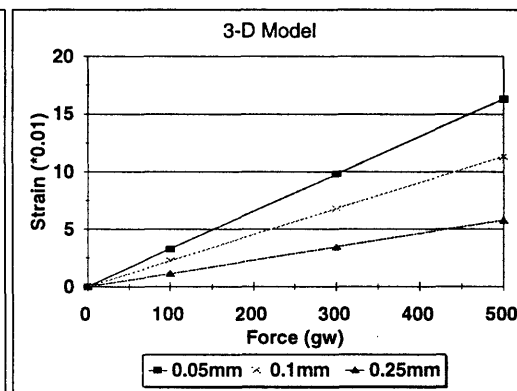

Fig 5.13 Strain vs. Force

As expected, the results of both the models show that the strain is linearly related to the applied force, which matches the experimental outcome. Further examination of the second characteristic, the proportion of the slopes between the lines, shows that the shell model is incorrect. For the 3-D model, the ratio of the slopes for three different thickness plates is 1:0.65:0.36. These ratios are almost exactly the same values as those from the experiments.

Since the 3-D model FEM analysis has been verified, it is used for future calculations. In the following section, we use this model to calculate the curvature of the plates. Figs 5.14 to 5.16 show the mesh of the 3-D model solved using ABAQUS.

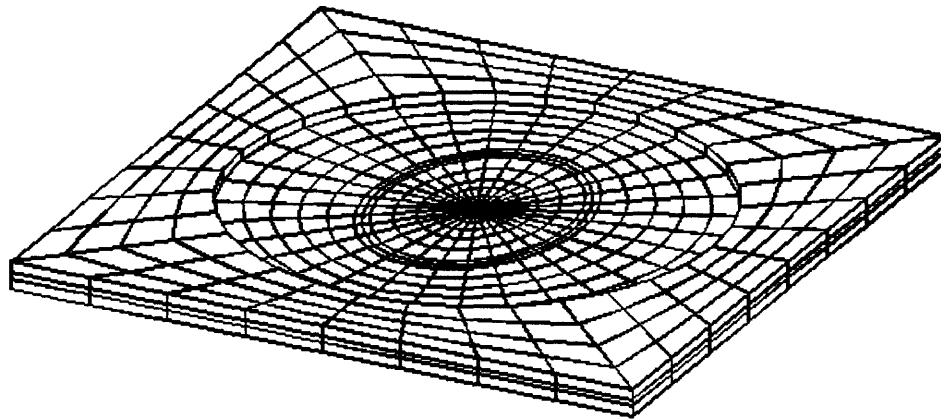

Fig 5.14 3-D Model -- original mesh

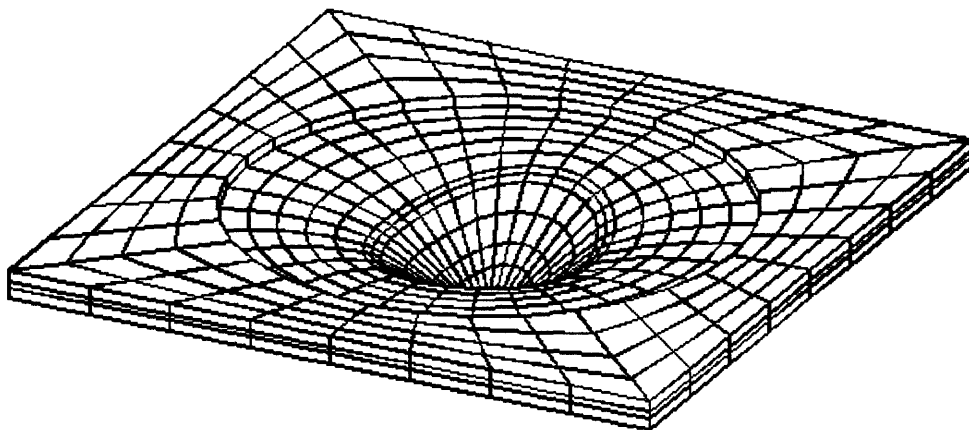

Fig 5.15 3-D Model -- with applied force

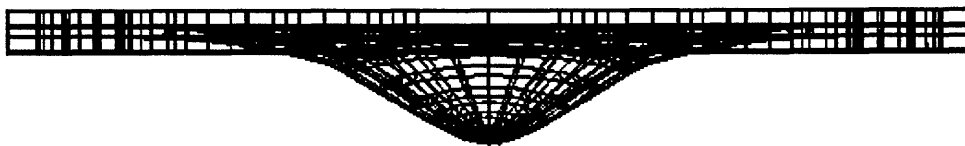

Fig 5.16 3-D Model -- with applied force, side view

Chapter 6

Results of Deformation Analysis

6.1 Relationship between Curvature and Thickness JND

From the analysis of the experimental data, as discussed in Chapter 4, the JND drops dramatically when the plate thickness lies below the critical value. It is likely that the decrease in the JND is the result of the increase of tactile information. As the material and surface texture variables were held constant in the experiments, it is hypothesized that plate curvature may be an important information source in providing an extra cue for fingers in discriminating thickness difference of plates thinner than the critical thickness.

To test this hypothesis, the curvature values for plates differing in thickness were calculated. This test was intended to find out if the curvature change between the standard plate and the plate thicker by 1 JND is constant for all the standard plates thinner than the critical thickness and independent of the plate material. In calculating the plate curvature for different materials and thicknesses, an applied force of 3 N and contact areas of 170 & 195 mm² (for index finger and thumb, respectively) were used. These values represent the average applied force and contact areas measured in trials for all the five subjects.

As the curvature values are different for different locations on a plate, three regions were picked for calculating the curvature value. One was the center of the contact area and the other two were the edges of the contact area (Fig 6.1). These three regions represented locations with the highest tactile sensation.

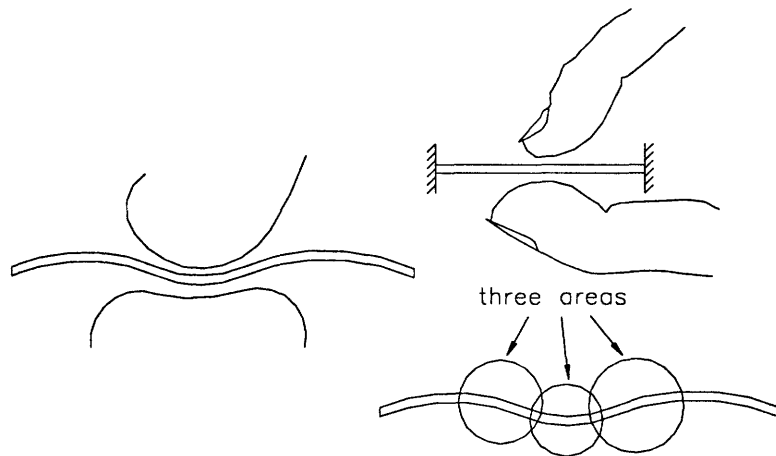

Fig 6.1 Areas for calculating the curvature

The curvature calculations below were based on the following four assumptions:

- The two fingers touch right at the center of the plate.
- The force is uniformly distributed within the contact area.
- The material properties of the plates are homogeneous, isotropic, and linear elastic.
- The deformation is within the linear range for the material.

The curvature was computed in a two-step method. The FEM analysis was first used to obtain plate deflection values which were interpolated to calculate the curvature. Similar to the strain computation in chapter 5, the same software ABAQUS was used for the FEM analysis and the model used in the input file was the 3-D element model. In this model, the distance between two nodes was about 0.5 mm within the contact areas of the

fingers and about 1.0 mm in the region outside the contact area. After running the ABAQUS, the deflection of each node was obtained. By using the mathematical software package MATLAB, the curvatures were calculated based on the nodal coordinates and the deflections of each node. Figs 6.2 and 6.4 show the variation of curvature for different thicknesses of plastic and steel plates respectively.

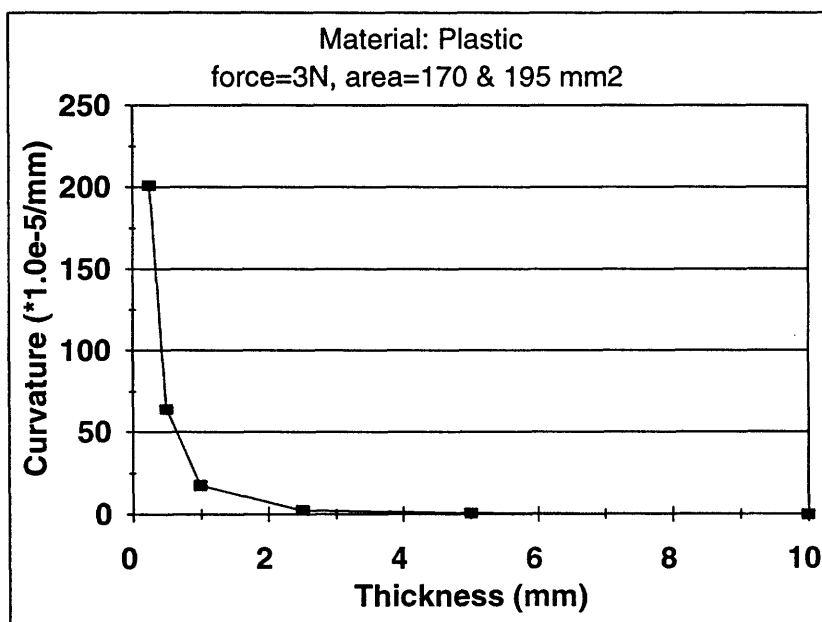

Fig 6.2 Curvature in different thicknesses of plastic plates

From Fig 6.2, it is obvious that the value of curvature is quite small when the plate is relatively thick and it becomes larger when the plate thickness decreases. In other words, there exists a critical thickness such that the curvature is relatively small when the plate thickness is larger than the critical value; or the curvature soars when the plate is thinner than the critical thickness. The critical thickness was estimated, from the graph, to be around 0.5 mm or 1.0 mm for plastic plates. This result is to be compared with the experimental results (Fig 6.3) where the subjects' JNDs begin to change dramatically when

the plate thickness is between 0.5 mm and 1.0 mm. The correlation between the soaring curvature and the plummeting JNDs as thickness reduces from the critical value explains the strong influence of tactile information on the JNDs. Because plate curvature gives rise to a tactile sensation, the drop in JND can be explained as due to the contribution of the extra tactile cue derived from plate curvature. In other words, when the plate thickness is larger than the critical value, the plate curvature is very small so that no additional information is supplied by tactile sources. Hence, the subjects' thickness discrimination JNDs are governed solely by the resolution limit of the kinesthetic sensation. On the other hand, when the plate is thinner than the critical thickness, the curvature becomes large enough to provide a cue through tactile sensation; it contributes to better thickness discrimination as shown by the plummeting JND values. In addition, this finding shows that tactile information has better thickness discrimination ability than kinesthetic information since it allows subjects to discriminate smaller thickness differences when the object is thin enough to be bendable.

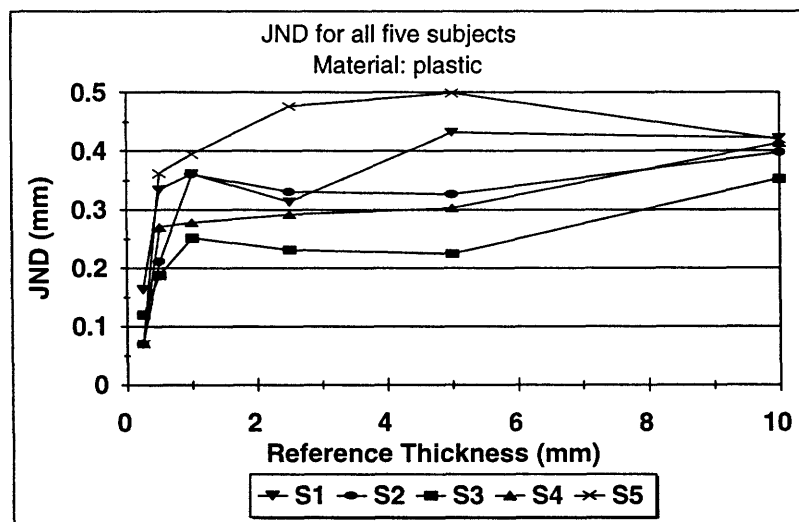

Fig 6.3 JNDs of 5 subjects for plastic plates

In a similar fashion, the value of curvature for steel plates with different thickness, as shown in Fig. 6.4, differs greatly depending on whether the plate is thicker or thinner than the critical value. From this graph, the critical thickness of the steel plate is estimated to be about between 0.1 mm and 0.25 mm. Comparing this curvature graph with the JNDs of all the five subjects as shown in Fig 6.5, the same strong correlation between the JNDs and the curvatures in the thinner plate range (plate thickness smaller than 0.25 mm) can be identified. The same reasoning as for plastic plates can be applied here to explain the relationship. That is, when the plate is thicker than this critical thickness, the curvature is too small to provide any additional tactile cue; therefore, the subjects' JND performance is limited by the kinesthetic resolution. When the plate is thinner than the critical thickness, the curvatures become large enough to provide subjects additional tactile information. With this extra tactile cue, subjects are able to discriminate the thickness difference better. This is supported by Fig 6.5 where, as the thickness decreases, the JNDs begin to decrease, an indication of better thickness discrimination ability, at roughly the same point where the curvature starts to increase.

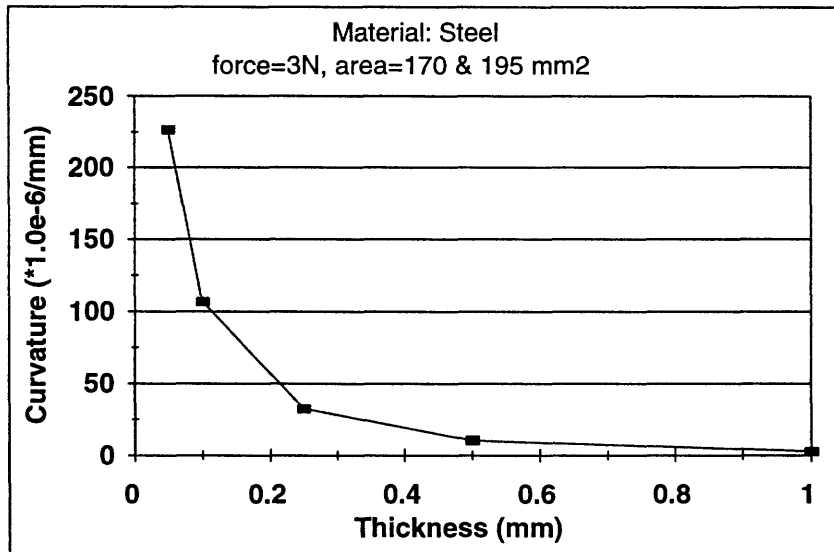

Fig 6.4 Curvature in different thicknesses of steel plates

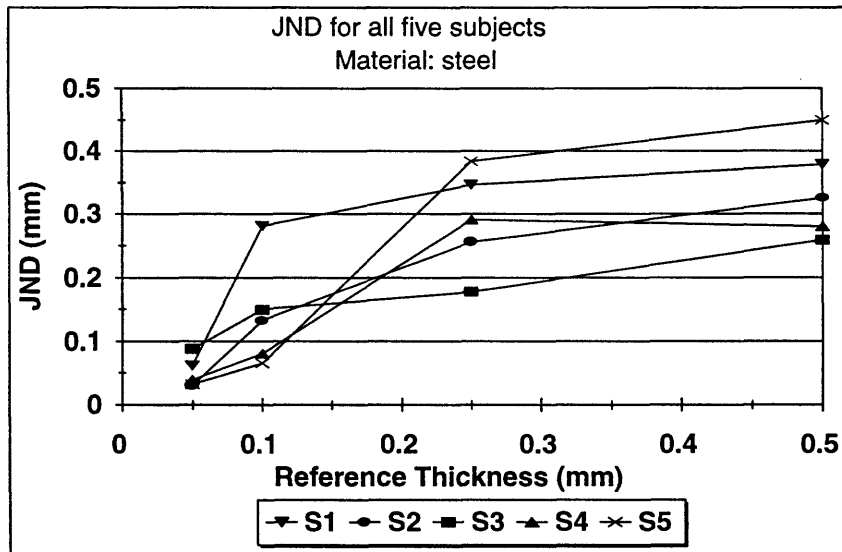

Fig 6.5 JND of five Subjects for steel plates

6.2 Curvature JND

As the plate curvature has been shown as an important cue for tactile sensation in discriminating the thickness of bendable plates, one interesting question arises: what are the resolution limits of this cue? That is, what is the curvature JND? Fig 6.6 illustrates

the reasoning of the curvature JND.

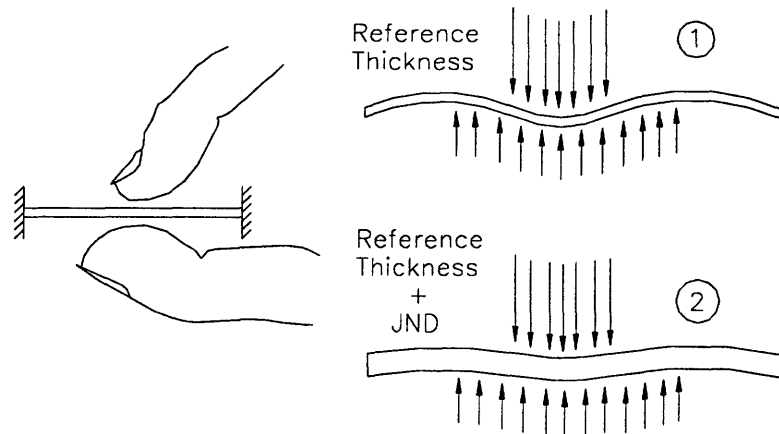

Fig 6.6 Illustration of how to calculate the curvature JND

In grasping a bendable plate whose thickness is below the critical value, subjects are likely to rely on the additional cue of plate curvature for discriminating the plate thickness. From the previous discussion, the enhanced discrimination ability as shown by the decreased JND, is solely contributed by the tactile cues arising from plate curvature. From the definition of JND, humans can barely discriminate the difference between the plate with reference thickness and the plate with thickness equal to reference thickness plus JND. If curvature is the variable that humans rely on for the discrimination, the curvature difference between the two plates is what humans can really differentiate, instead of the thickness difference. As shown in Fig 6.6, even when the same force and contact areas are used to do the discrimination, as the thicknesses of the plates are different, the curvatures of the two plates are different. If the JNDs in the bendable plate group are solely due to the plate curvature as it provides tactile cues for the subjects, it is reasonable to estimate the curvature JND as the difference in these two curvature values.

It is assumed that the subjects use the same force when discriminating the two different thickness plates. This assumption is reasonable as the subjects did not know in which order the plates were presented in each trial. Without prior expectation of plate thickness, the subjects would use, on the average, the same force to grasp the plates.

Two pieces of data, applied force and contact area, are needed for calculating the curvature. It is reasonable that subjects used the same force on discriminating the same pair. But it is not necessarily true that subjects use the same force on discriminating all the different thickness plate pairs. Hence, measuring the actual forces used by the subjects in different sessions is necessary.

6.2.1 Measurement of Applied Force

The applied forces were measured after the subject had completed all the experiments for determining the JNDs. When measuring the applied force, the subjects were asked to discriminate pairs of plates with different thickness -- three pairs for the plastic plates and four pairs for the steel plates. These pairs belonged to the bendable group. During each pairwise discrimination, four plates were presented: two were the reference plates and the other two were the comparison plates with the thickness approximately equal to the reference thickness plus the corresponding JND for that subject and reference thickness. The UniForce sensor was attached to one of the plates. While the subjects were concentrating on the discrimination, their applied forces were measured at the same time by using the UniForce sensor. The force used for the calculation was the average of at

least twenty trials. Table 6.1 shows the values of the averaged force and their standard deviations for each of the reference plates.

Table 6.1 Force used by the subjects (Unit: gw)

Subject		S1	S2	S3	S4	S5
Plastic 1.0 mm	Average	120	158.85	24.0	1198.6	699.25
	S.D	25.4	22.2	3.92	247.6	102.3
Plastic 0.5 mm	Average	122.2	129.4	33.0	1216.7	586
	S.D	22.5	15.4	5.02	347.7	66.08
Plastic 0.25 mm	Average	87.13	47.11	27.2	1465.4	511.64
	S.D	14.3	10.7	4.12	222.5	102.7
Steel 0.5 mm	Average	80	165.95	29.1	1152.8	731.19
	S.D	14.1	17.8	4.03	208.8	102.7
Steel 0.25 mm	Average	79.35	107.33	34.3	883.53	461.86
	S.D	15.23	11.9	4.29	203.3	60.27
Steel 0.1 mm	Average	53.74	81.82	32.6	1531.5	177.96
	S.D	6.94	11.5	5.18	138.4	35.18
Steel 0.05 mm	Average	31.25	56.14	37.4	1324.7	111.16
	S.D	5.18	11.5	5.23	218	26.21

From the table it is found that different subjects preferred different forces for thickness discrimination. Even for the same subject, the applied force is not necessary the same for different reference thicknesses.

6.2.2 Measurement of Contact Areas

The values of contact areas for each reference thickness were measured right after the measurement of applied forces for each of the reference plates used in pairwise discrimination. Subjects' fingers were inked before they were instructed to touch the

plates using the same force as they used in the discrimination. When the fingerprints were obtained in this way, their areas were measured using the same method as mentioned in Chapter 5. Table 6.2 shows the values of the contact areas.

Table 6.2 Contact Areas for five subjects (Unit: mm²)

Subject		S1	S2	S3	S4	S5
Plastic 1.0 mm	Thumb	115	280	110	180	220
	Index F.	90	180	80	100	180
Plastic 0.5 mm	Thumb	115	290	120	180	300
	Index F.	90	220	85	120	200
Plastic 0.25 mm	Thumb	110	130	120	145	200
	Index F.	85	110	95	125	170
Steel 0.5 mm	Thumb	110	330	160	145	290
	Index F.	85	280	110	105	230
Steel 0.25 mm	Thumb	112	320	170	160	190
	Index F.	85	270	110	115	120
Steel 0.1 mm	Thumb	100	300	160	160	260
	Index F.	80	240	110	110	160
Steel 0.05 mm	Thumb	95	220	160	110	160
	Index F.	75	170	120	90	110

6.2.3 Curvature JND

Applying the same two-step method described in Section 6.1, the plate curvature was calculated. For each subject, the curvature of plates with different thicknesses were computed. Table 6.1 and Table 6.2. shows the actual values of the applied forces and the contact areas for each subject used in the calculation. Specifically, the curvature for each reference plate and that for the comparison plate, with a thickness equal to that of the

reference plate plus the subject's JND, was obtained. The curvature JND was computed as the curvature difference between the two plates. Fig 6.7 shows the predicted curvature JND for plastic and Fig 6.8 for steel. In plastic the thickest one included in the calculation was 1.0 mm, as those thicker than 1.0 mm are found to be less likely to bend and hence have too small a curvature to provide tactile cues to the subjects.

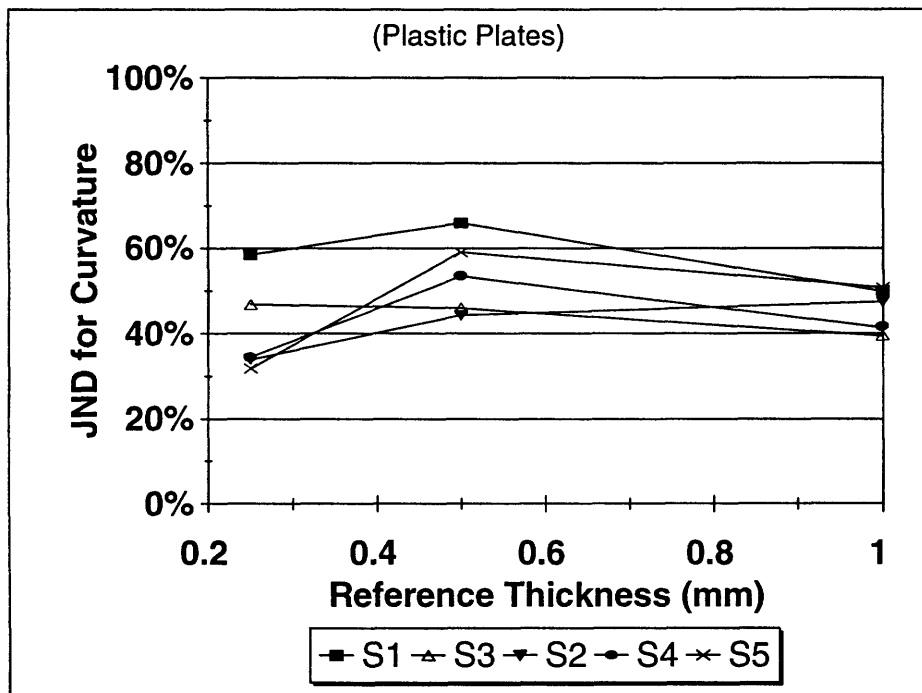

Fig 6.7 Predicted Curvature JND of each Subjects for Plastic Plates

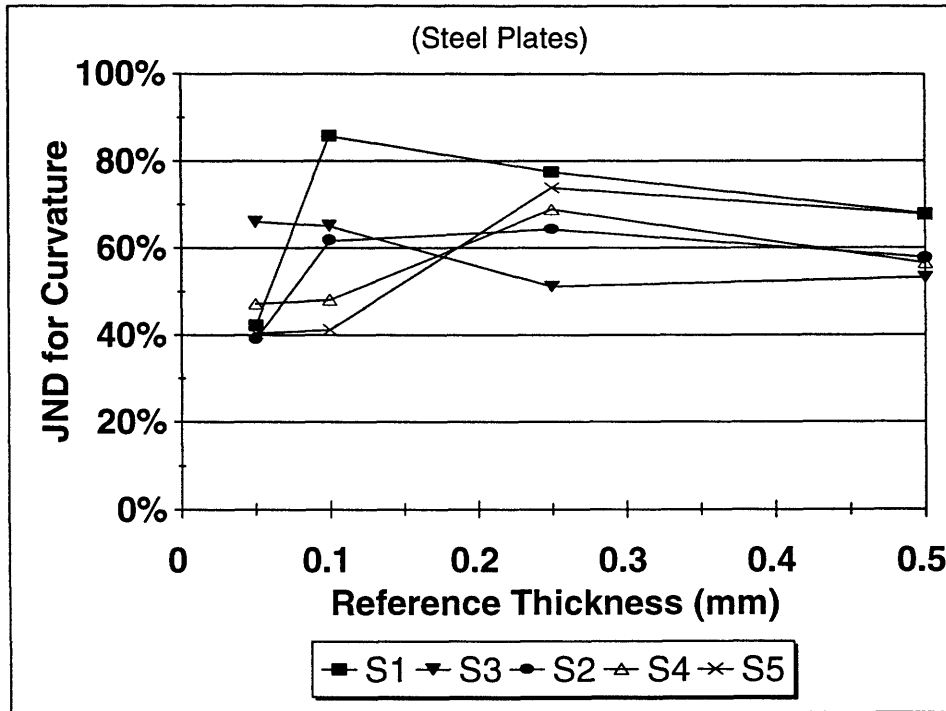

Fig 6.8 Predicted Curvature JND of each Subjects for Steel Plates

From Fig 6.7, it is observed that the curvature JND for plastic, expressed as a percentage, lies between 40% to 60%. Similarly, as shown in Fig 6.8, the curvature JND for steel is between 40% to 80%. For both cases, % JND remains approximately constant with respect to reference thickness. Although there is some variation for each subject, it is much smaller than those for thickness as shown in Fig 6.3 and 6.5. From these observations, we may conclude that humans are able to discriminate roughly 50% difference in plate curvature, during active grasping of thin plates. This finding is important as it allows us to estimate human resolution in thickness discrimination when an object is bendable.

Chapter 7

Discussion and Conclusions

7.1 Discussion

The experimental findings on human thickness discrimination can be discussed in two distinct contexts: the unbendable object and the bendable object. For the unbendable object, the average thickness JND for humans is about 0.3 mm to 0.5 mm. This finding is consistent with the finger joint angle JND study conducted by Tan and Srinivasan (1994). The basic idea of their experiment is showed in Fig 7.1. The subjects placed their index fingers on a plate. The plate, which is attached to a stepper motor that is controlled by a computer, can rotate to a desired angle. Their discrimination experiments showed that the joint angle JND is about 1.9° to 2.5° .

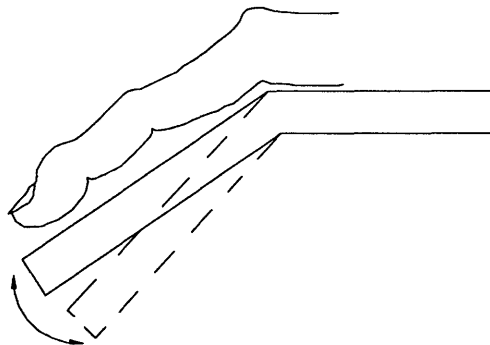

Fig 7.1 Experiment to determine finger joint angle JND

Assuming a typical finger length of 100 mm, if the joint angle JND can be transferred into thickness JND as in our case (Fig 7.2), we obtain a value of 0.33 mm to 0.44 mm. As the kinesthetic information in this context conveys only different angles of joint movement, it is reasonable to expect that the thickness JND should be between 0.33 mm and 0.44 mm if only kinesthetic information is used to discriminate plate thickness. In our thickness discrimination experiment for the unbendable plates, the JNDs fall between 0.3 mm and 0.5 mm for all the subjects with only one exception: 0.25 mm for one subject. Comparing our findings with the study conducted by Tan and Srinivasan, the predicted and measured human thickness JNDs are approximately the same. Therefore, it can be concluded that humans rely solely on kinesthetic cues for thickness discrimination when the object encountered is unbendable. The thickness JND for the unbendable object is limited by the kinesthetic resolution and is about 0.3 mm to 0.5 mm. This also explains why the JND is roughly the same value for all the unbendable plates, no matter how thick the plate was in this study.

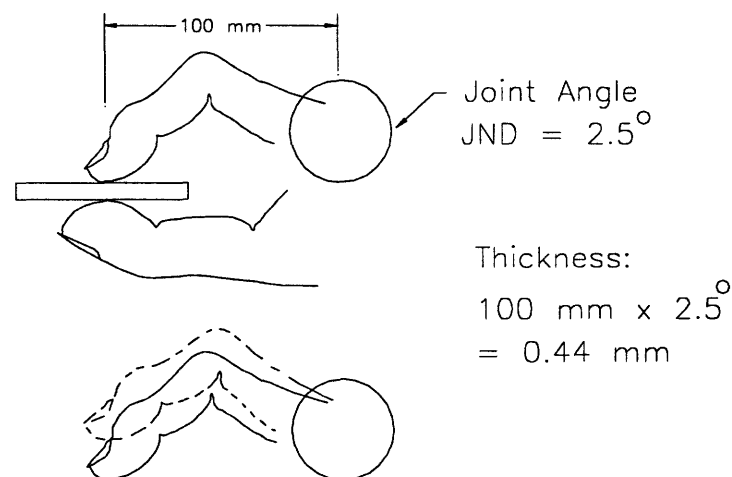

Fig 7.2 Transformation of joint angle JND in thickness JND

When compared with other studies of human tactual thickness discrimination (John et al, 1989, and Durlach, et al, 1989), the findings here are also consistent with their results. The study done by John et al in exploring the human resolution of thickness of very thin plates showed that the subjects could discriminate a difference in thickness of about 0.075 mm when the standard plate thickness was 0.2 mm. The study on length discrimination by Durlach, et al showed that subjects could discriminate a difference of about 1 mm when the standard length was 10 mm. Based on the results described in this thesis, the large resolution difference in the two thickness ranges can be explained as because one (0.2 mm) was in the bendable range and the other one (10 mm) was in the unbendable range. Since subjects could rely on tactile cues to discriminate the thickness when the plates were bendable, the resolution would be much better than when the plates were unbendable, in which case subjects would have to rely solely on kinesthetic cues for thickness discrimination.

However, the hypotheses proposed by John et al were not supported by our findings. All the three hypotheses (stated in section 1.2) suggested by them implied that kinesthetic information provided the dominant cue in the thickness discrimination even when the plates were very thin. Our results show that these hypotheses are incorrect since subjects could not achieve such a high resolution by relying only on kinesthetic information. It would be the tactile cues that helped the subjects to better discriminate the thickness when the plate thickness was 0.2 mm.

7.2 Conclusions

Based on the findings in these experiments, the following conclusions could be made:

- The human tactual ability in discriminating thickness did not follow the Weber's law when the thickness range was between 0.05 mm to 10 mm. As the reference thickness reduced, the values of % JND always increased first and then decreased.
- For each material there was always a critical thickness beyond which the JND values in terms of thickness increment remained about the same for all higher values of the reference thickness. When the reference plate was thinner than the critical thickness, the JND values decreased as the reference thickness decreased. The critical thickness was between 0.5 mm to 1.0 mm for plastic plates and between 0.1 mm to 0.25 mm for steel plates.
- The thickness JND for both plastic and steel plates was measured to be about 0.3 mm to 0.5 mm when the reference plate was thicker than the critical thickness. When the reference plates were very thin, the thickness resolution of all the five subjects improved dramatically. Some subjects could even discriminate a thickness difference as small as 0.03 mm.
- Based on the experimental findings, the following hypotheses were proposed:(1) when the plates were thicker than the critical thickness, it is likely that the plates were unbendable and the thickness JND was limited by the kinesthetic resolution; (2) when the plates were thinner than the critical thickness, the plates became bendable and

subjects could rely on the tactile cue obtained from the changes in plate curvature to better discriminate the thickness, which resulted in decreased JND.

- From the analysis of plate deformation by using finite element methods, it was found that the plate curvature was relatively small when the plate thickness was larger than the critical thickness. The plate curvature became large when the plates were thinner than the critical thickness. These results support the hypotheses stated above.
- Based on measurement of the applied force and the fingers' contact areas used by each subject for different reference thicknesses, finite element models were used to compute the curvature for each reference plate and that for the comparison plate, with a thickness equal to that of the reference plate plus the subject's JND. The curvature JND was computed as the curvature difference between the two plates under peak force values. It was found to be approximately constant over reference thicknesses in the bendable range and about the same for plastic and steel plates, thus explaining the human discrimination performance for all bendable plates in a unified manner. The predicted curvature JND based on finite element analysis for actively grasped thin plates is about $60 \pm 20\%$.

Appendix A: Experimental Results for Individual Subjects

1. Tables in this appendix give the results for each subject. Session number, plate material, and the thickness of the reference plates are given at top. Each column represents the results for one of the four pairs of plates. Thickness difference between the reference and the comparison plates is indicated at the top of each column. The corresponding confusion matrix, d' , and bias are also given. The value of JND is given at the bottom of the table.
2. In each confusion matrix, the first row represents the signal that the first plate is thicker and the second row represents the signal that the second plate is thicker. The first column represents the subject's response that the first plate is thicker. The second column represents the subject's response that the second plate is thicker.
3. We used 2-interval, 2-alternative-forced choice paradigm as our decision model. In the 2-interval experiment the subjects grasp the first plate, then the second plate, and then are asked to key in their responses. An alternative procedure would be a 1-interval experiment when the subjects grasp only one plate (either the thick plate or the thin plate presented randomly with equal probability) and then are asked to give their responses. Generally speaking, the subjects need to rely less on memory in 2-interval than in 1-interval experiment. In psychophysics literature, it is common practice to express the results of the 2-interval experiments in terms of 1-interval experiments by dividing the d' by square root of 2. After this conversion, the value of JND from the two methods will be approximately the same. For the results showed in the following tables, the 2-interval d' s are already divided by square root of 2.

4. A positive value of bias means the subject has a tendency to respond that plate one is thicker more number of times than responding that plate two is thicker. If the bias is very large, it will influence the value of d' . For example, if two confusion matrices have the same percentage of correct responses, the one with a larger value of bias will have a larger values of d' . For a 1-interval decision model, a bias is typically acceptable if its value is not larger than 10 % of d' . Because we used 2-interval experiments, we can accept the bias if its value is not larger than 15% of d' .
5. If there is a zero in the confusion matrix, the calculated d' will be infinite. In the following tables, we use "0.5" to replace the zero and subtract 0.5 from the other response for the same signal. For example, if the responses for a signal are 128 and 0, we will use 127.5 and 0.5 to calculate the d' .
6. A graph relating the d' and thickness difference is shown at the right of each table.

A.1 Subject: S1

Session 1 Plastic Plates Reference thickness = 10.0 mm								
thickness difference	0.25mm 2.5%		0.5mm 5%		1mm 10%		1.5mm 15%	
confusion matrix	76	37	105	23	122	6	128	0
	42	86	36	92	7	121	0	128
dprime	0.63		1.06		2.32		3.76	
bias	0.00		0.17		0.04		0	
JND = 4.2% , 0.42mm								

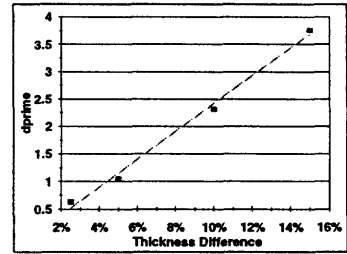

Session 2 Plastic Plates Reference thickness = 5.0 mm						
thickness difference	0.25mm 5%		0.5mm 10%		1mm 20%	
confusion matrix	82	46	110	18	118	10
	45	83	22	106	21	107
dprime	0.52		1.43		2.03	
bias	-0.01		0.07		-0.32	
JND = 8.7% , 0.44mm						

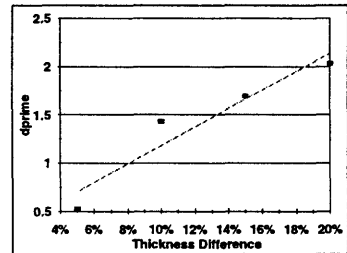

Session 3 Plastic Plates Reference thickness = 2.5 mm						
thickness difference	0.25mm 10%		0.5mm 20%		1mm 40%	
confusion matrix	79	49	121	7	123	5
	26	102	23	105	7	121
dprime	0.80		1.78		2.85	
bias	-0.27		0.34		0.65	
JND = 12.5% , 0.31mm						

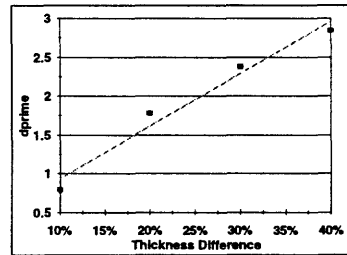

Session 4 Plastic Plates Reference thickness = 1.0 mm						
thickness difference	0.3mm 30%		0.5mm 50%		0.85mm 85%	
confusion matrix	93	35	96	32	114	14
	28	100	22	106	10	118
dprime	0.97		1.15		2.41	
bias	-0.09		-0.14		-0.09	
JND = 36.2% , 0.36mm						

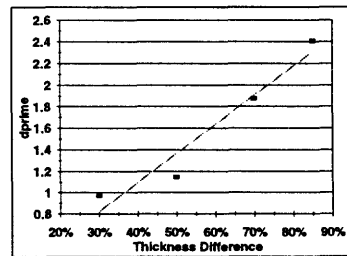

Session 5 Plastic Plates Reference thickness = 0.5 mm						
thickness difference	0.15mm 30%		0.25mm 50%		0.8mm 160%	
confusion matrix	69	59	83	56	108	20
	42	86	25	103	14	114
dprime	0.38		0.88		2.17	
bias	-0.17		-0.24		-0.11	
JND = 67.0% , 0.34mm						

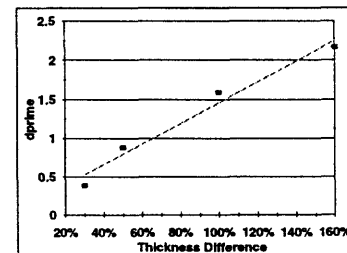

Session 6 Plastic Plates Reference thickness = 0.25 mm				
thickness difference	0.05mm 20%	0.1mm 40%	0.25mm 100%	0.35mm 140%
confusion matrix	71 57 45 83	79 49 33 95	100 28 16 112	111 17 11 117
dprime	0.37	0.67	1.36	1.75
bias	-0.12	-0.18	-0.19	-0.13
JND = 65.4% , 0.16mm				

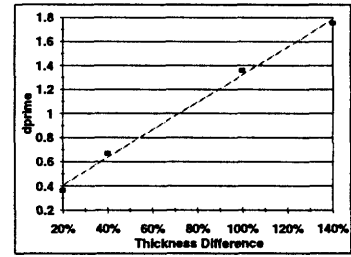

Session 7 Steel Plates Reference thickness = 0.5 mm				
thickness difference	0.275mm 55%	0.4mm 80%	0.5mm 100%	0.775mm 155%
confusion matrix	85 43 35 93	103 25 25 103	100 28 17 111	111 17 12 116
dprime	0.72	1.21	1.34	1.72
bias	-0.09	0.0	-0.17	-0.10
JND = 75.8% , 0.38mm				

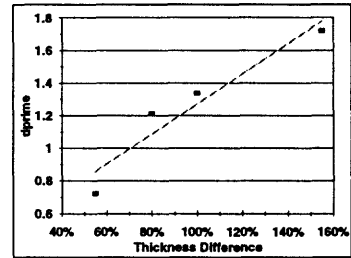

Session 8 Steel Plates Reference thickness = 0.25 mm				
thickness difference	0.25mm 100%	0.375mm 150%	0.525mm 210%	0.65mm 260%
confusion matrix	84 44 28 100	92 36 18 110	104 24 27 101	120 8 19 109
dprime	0.83	1.17	1.20	1.82
bias	-0.19	-0.25	0.04	0.25
JND = 138.7% , 0.35mm				

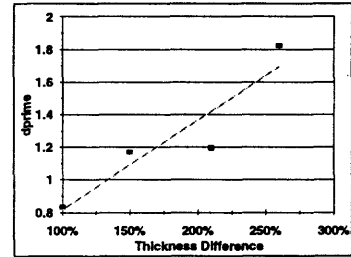

Session 9 Steel Plates Reference thickness = 0.1 mm				
thickness difference	0.1mm 100%	0.275mm 275%	0.4mm 400%	0.525mm 525%
confusion matrix	73 55 41 87	89 39 38 90	102 26 15 113	118 10 17 111
dprime	0.45	0.74	1.43	1.79
bias	-0.14	-0.01	-0.18	0.15
JND = 281.5% , 0.28mm				

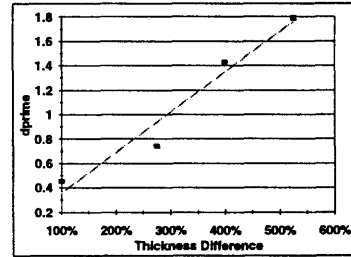

Session 10 Steel Plates Reference thickness = 0.05 mm				
thickness difference	0.05mm 100%	0.15mm 300%	0.2mm 400%	0.325mm 650%
confusion matrix	103 25 16 112	122 6 9 119	124 4 7 121	127 1 2 126
dprime	1.42	2.23	2.45	3.23
bias	-0.15	0.10	0.13	0.13
JND = 122.2% , 0.06mm				

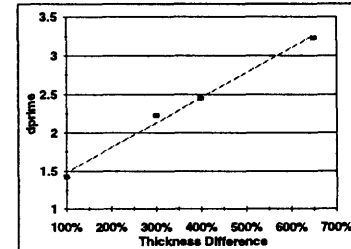

A.2 Subject: S2

Session 1 Plastic Plates Reference thickness = 10.0 mm								
thickness difference	0.25mm 2.5%		0.5mm 5%		1mm 10%		1.5mm 15%	
confusion matrix	84	44	69	59	110	18	128	0
	16	112	22	106	9	119	1	128
dprime	1.10		0.74		1.80		3.59	
bias	-0.37		-0.42		-0.20		0.12	
JND = 4.0% , 0.4mm								

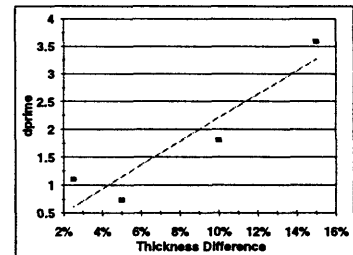

Session 2 Plastic Plates Reference thickness = 5.0 mm								
thickness difference	0.25mm 5%		0.5mm 10%		0.75mm 15%		1mm 20%	
confusion matrix	94	34	115	13	119	9	117	11
	34	94	14	114	11	117	2	126
dprime	0.88		1.77		2.01		2.49	
bias	0.0		0.02		0.05		-0.39	
JND = 6.5% , 0.33mm								

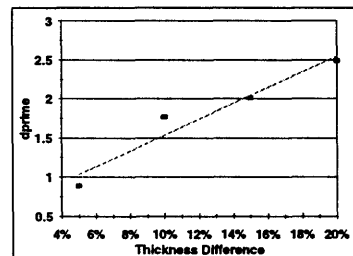

Session 3 Plastic Plates Reference thickness = 2.5 mm								
thickness difference	0.25mm 10%		0.5mm 20%		0.75mm 30%		1mm 40%	
confusion matrix	107	21	121	7	124	4	126	2
	45	83	26	102	27	101	18	110
dprime	0.96		1.72		1.89		2.29	
bias	0.30		0.39		0.53		0.54	
JND = 13.2% , 0.33mm								

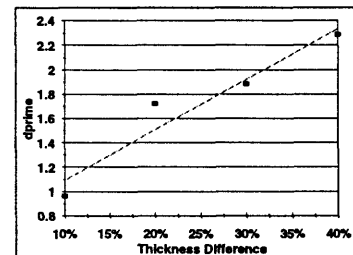

Session 4 Plastic Plates Reference thickness = 1.0 mm								
thickness difference	0.3mm 30%		0.5mm 50%		0.7mm 70%		0.85mm 85%	
confusion matrix	84	44	107	21	123	5	126	2
	36	92	33	95	11	117	4	124
dprime	0.69		1.15		2.21		2.84	
bias	-0.09		0.16		0.21		0.15	
JND = 36.0% , 0.36mm								

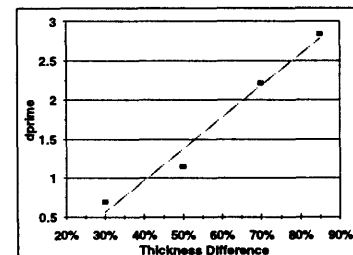

Session 5 Plastic Plates Reference thickness = 0.5 mm								
thickness difference	0.15mm 30%		0.25mm 50%		0.5mm 100%		0.8mm 160%	
confusion matrix	85	43	97	31	123	5	127	1
	27	101	20	108	12	116	2	126
dprime	0.87		1.21		2.18		3.23	
bias	-0.19		-0.16		0.22		0.13	
JND = 42.1% , 0.21mm								

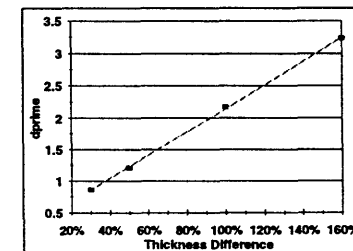

Session 6 Plastic Plates Reference thickness = 0.25 mm				
thickness difference	0.05mm 20%	0.1mm 40%	0.25mm 100%	0.35mm 140%
confusion matrix	78 50 31 97	115 13 7 121	124 4 1 127	128 0 0 128
dprime	0.69	2.03	3.03	3.76
bias	-0.21	-0.16	-0.28	0.0
JND = 28.1% , 0.07mm				

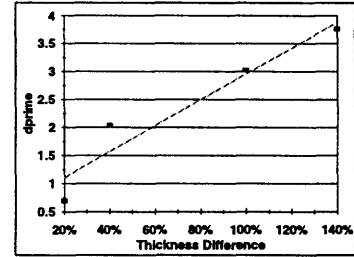

Session 7 Steel Plates Reference thickness = 0.5 mm				
thickness difference	0.275mm 55%	0.4mm 80%	0.5mm 100%	0.775mm 155%
confusion matrix	86 42 27 101	94 34 17 111	108 20 15 113	119 9 6 122
dprime	0.88	1.23	1.56	2.23
bias	-0.18	-0.24	-0.09	-0.10
JND = 65.2% , 0.33mm				

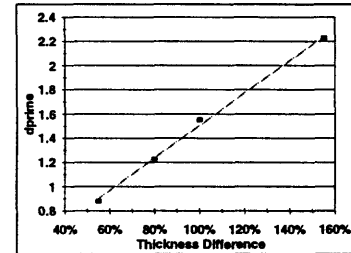

Session 8 Steel Plates Reference thickness = 0.25 mm				
thickness difference	0.25mm 100%	0.375mm 150%	0.525mm 210%	0.65mm 260%
confusion matrix	99 29 25 103	98 30 12 116	111 17 6 122	118 10 5 123
dprime	1.14	1.44	1.98	2.25
bias	-0.05	-0.30	-0.28	-0.17
JND = 102.5% , 0.26mm				

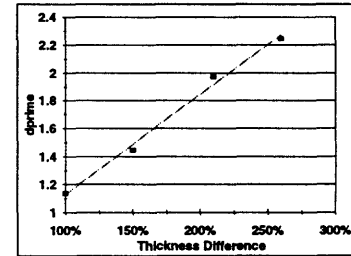

Session 9 Steel Plates Reference thickness = 0.1 mm				
thickness difference	0.1mm 100%	0.275mm 275%	0.4mm 400%	0.525mm 525%
confusion matrix	78 50 21 107	112 16 12 116	126 2 1 127	128 0 1 127
dprime	0.89	1.75	3.23	3.59
bias	-0.35	-0.08	-0.13	0.12
JND = 132.7% , 0.13mm				

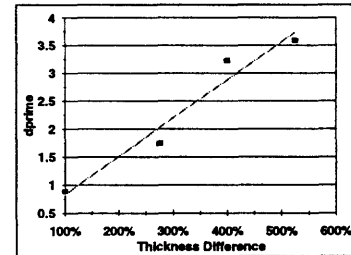

Session 10 Steel Plates Reference thickness = 0.05 mm				
thickness difference	0.025mm 50%	0.075mm 150%	0.15mm 300%	0.2mm 400%
confusion matrix	104 24 19 109	122 6 3 125	126 2 1 127	128 0 0 128
dprime	1.36	2.59	3.23	3.76
bias	-0.08	-0.16	-0.13	0.0
JND = 61.8% , 0.03mm				

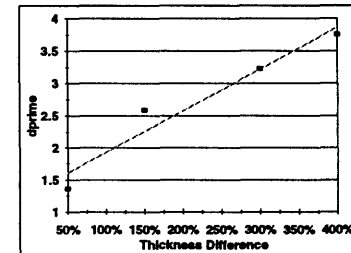

A.3 Subject: S3

Session 1 Plastic Plates Reference thickness = 10.0 mm				
thickness difference	0.25mm 2.5%	0.5mm 5%	1mm 10%	1.5mm 15%
confusion matrix	109 19 22 10	97 31 31 97	116 12 9 119	124 4 4 124
dprime	1.14	0.99	1.97	2.63
bias	0.05	0.0	-0.08	0.0
JND = 3.5% , 0.35mm				

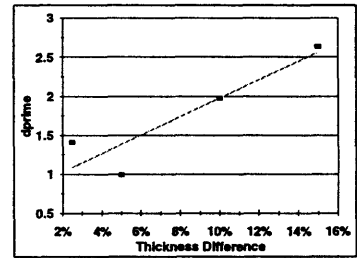

Session 2 Plastic Plates Reference thickness = 5.0 mm				
thickness difference	0.25mm 5%	0.5mm 10%	0.75mm 15%	1mm 20%
confusion matrix	114 14 17 111	119 9 11 117	125 3 2 126	124 4 0 128
dprime	1.66	2.01	2.93	3.20
bias	0.06	0.05	-0.08	-0.40
JND = 4.5% , 0.23mm				

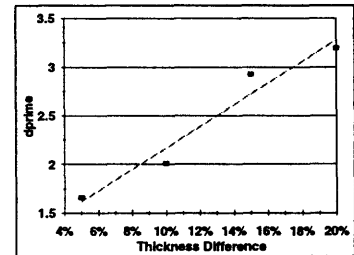

Session 3 Plastic Plates Reference thickness = 2.5 mm				
thickness difference	0.25mm 10%	0.5mm 20%	0.75mm 30%	1mm 40%
confusion matrix	111 17 16 112	119 9 4 124	123 5 6 122	126 2 3 125
dprime	1.60	2.36	2.43	2.93
bias	-0.02	-0.19	0.04	0.08
JND = 9.3% , 0.23mm				

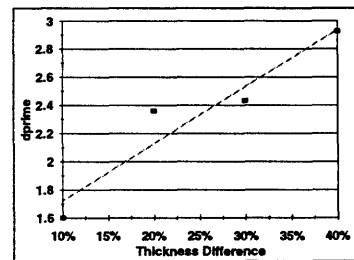

Session 4 Plastic Plates Reference thickness = 1.0 mm				
thickness difference	0.3mm 30%	0.5mm 50%	0.7mm 70%	0.85mm 85%
confusion matrix	116 12 36 92	123 5 10 118	124 4 5 123	123 5 2 126
dprime	1.34	2.25	2.56	2.77
bias	0.37	0.17	0.05	-0.20
JND = 25.2% , 0.25mm				

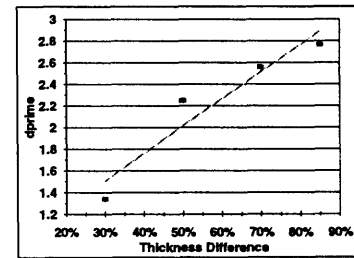

Session 5 Plastic Plates Reference thickness = 0.5 mm				
thickness difference	0.15mm 30%	0.25mm 50%	0.5mm 100%	0.8mm 160%
confusion matrix	100 28 27 101	116 12 26 102	121 7 7 121	126 2 8 120
dprime	1.12	1.52	2.26	2.61
bias	-0.01	0.24	0.0	0.31
JND = 37.5% , 0.19mm				

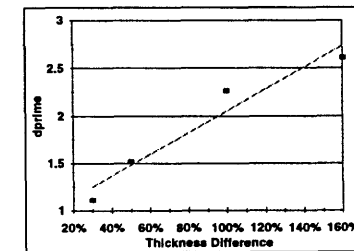

Session 6 Plastic Plates Reference thickness = 0.25 mm				
thickness difference	0.05mm 20%	0.1mm 40%	0.25mm 100%	0.35mm 140%
confusion matrix	74 54 45 83	95 33 19 109	104 24 13 115	119 9 3 125
dprime	0.41	1.20	1.53	2.45
bias	-0.09	-0.20	-0.19	-0.26
JND = 48.1% , 0.12mm				

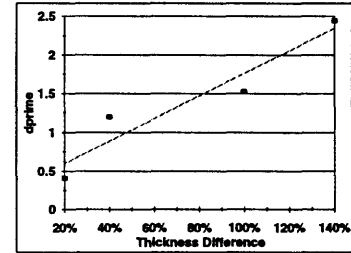

Session 7 Steel Plates Reference thickness = 0.5 mm				
thickness difference	0.275mm 55%	0.4mm 80%	0.5mm 100%	0.775mm 155%
confusion matrix	90 38 34 94	108 20 23 105	124 4 5 123	127 1 4 124
dprime	0.82	1.36	2.56	3.03
bias	-0.05	0.05	0.05	0.28
JND = 51.9% , 0.26mm				

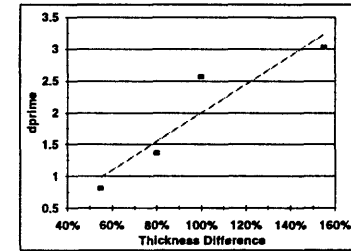

Session 8 Steel Plates Reference thickness = 0.25 mm				
thickness difference	0.25mm 100%	0.375mm 150%	0.525mm 210%	0.65mm 260%
confusion matrix	111 17 15 113	124 4 12 116	123 5 8 120	127 1 0 128
dprime	1.63	2.25	2.33	3.59
bias	-0.04	0.27	0.11	-0.12
JND = 71.2% , 0.18mm				

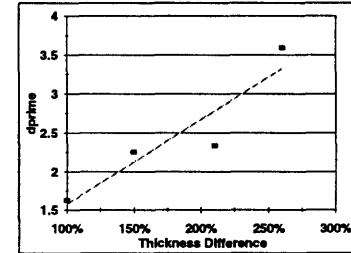

Session 9 Steel Plates Reference thickness = 0.1 mm				
thickness difference	0.1mm 100%	0.275mm 275%	0.4mm 400%	0.525mm 525%
confusion matrix	95 33 32 96	108 20 15 113	123 5 4 124	126 2 5 123
dprime	0.94	1.56	2.56	2.77
bias	-0.01	-0.09	-0.05	0.20
JND = 149.8% , 0.15mm				

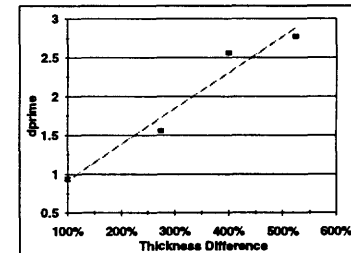

Session 10 Steel Plates Reference thickness = 0.05 mm				
thickness difference	0.05mm 100%	0.075mm 150%	0.15mm 300%	0.2mm 400%
confusion matrix	75 53 47 81	86 42 39 89	122 6 7 121	124 4 4 124
dprime	0.39	0.68	2.32	2.63
bias	-0.06	-0.03	0.04	0.0
JND = 175.9% , 0.09mm				

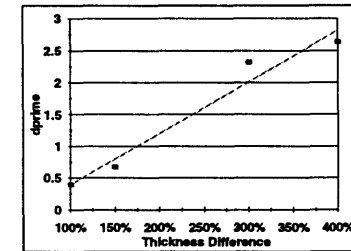

A.4 Subject: S4

Session 1 Plastic Plates Reference thickness = 10.0 mm				
thickness difference	0.25mm 2.5%	0.5mm 5%	1mm 10%	1.5mm 15%
confusion matrix	85 43 39 89	99 29 25 103	122 6 3 125	127 1 2 126
dprime	0.66	1.14	2.59	3.23
bias	-0.04	-0.05	-0.16	0.13
JND = 4.1% , 0.41mm				

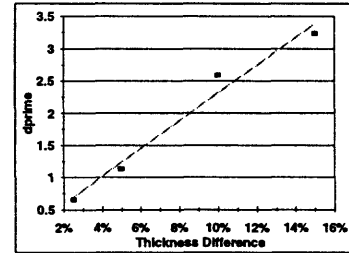

Session 2 Plastic Plates Reference thickness = 5.0 mm				
thickness difference	0.25mm 5%	0.5mm 10%	0.75mm 15%	1mm 20%
confusion matrix	85 43 41 87	110 18 12 116	123 5 2 126	127 1 0 128
dprime	0.63	1.69	2.77	3.59
bias	-0.02	-0.12	-0.20	-0.12
JND = 6.1% , 0.31mm				

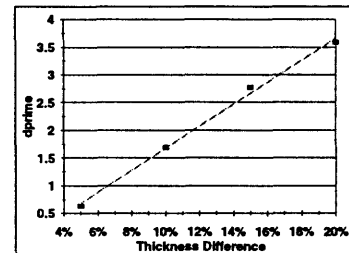

Session 3 Plastic Plates Reference thickness = 2.5 mm				
thickness difference	0.25mm 10%	0.5mm 20%	0.75mm 30%	1mm 40%
confusion matrix	97 31 24 104	101 27 9 119	120 8 3 125	124 4 4 124
dprime	1.12	1.61	2.49	2.63
bias	-0.09	-0.34	-0.23	0.0
JND = 11.7% , 0.29mm				

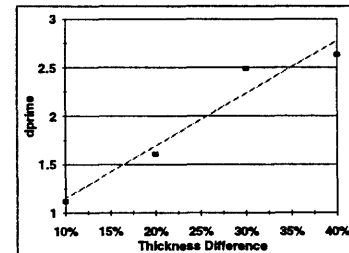

Session 4 Plastic Plates Reference thickness = 1.0 mm				
thickness difference	0.3mm 30%	0.5mm 50%	0.7mm 70%	0.85mm 85%
confusion matrix	98 30 33 95	113 18 8 120	121 7 3 125	126 2 1 127
dprime	0.97	1.85	2.54	3.23
bias	0.04	-0.23	-0.19	-0.13
JND = 27.9% , 0.28mm				

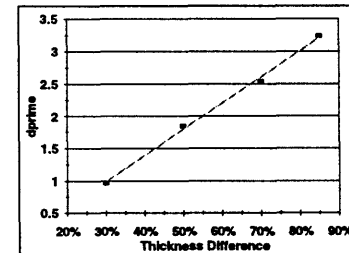

Session 5 Plastic Plates Reference thickness = 0.5 mm				
thickness difference	0.15mm 30%	0.25mm 50%	0.5mm 100%	0.8mm 160%
confusion matrix	88 40 49 79	91 37 33 95	112 16 7 121	126 2 2 126
dprime	0.56	0.85	1.95	3.05
bias	0.10	-0.05	-0.23	0.0
JND = 54.0% , 0.27mm				

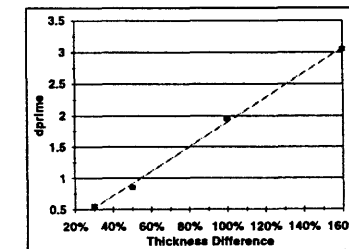

Session 6 Plastic Plates Reference thickness = 0.25 mm						
thickness difference	0.05mm 20%	0.1mm 40%	0.25mm 100%	0.35mm 140%		
confusion matrix	99 29 37 91	115 13 16 112	124 4 3 125	127 1 3 125		
dprime	0.92	1.71	2.72	3.12		
bias	0.10	0.06	-0.06	0.22		
JND = 28.9% , 0.07mm						

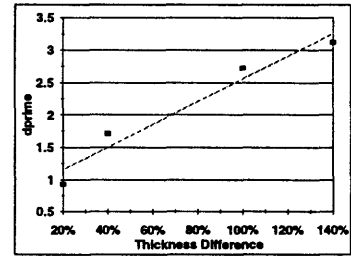

Session 7 Steel Plates Reference thickness = 0.5 mm						
thickness difference	0.275mm 55%	0.4mm 80%	0.5mm 100%	0.775mm 155%		
confusion matrix	98 30 36 92	116 12 20 108	118 10 14 114	125 3 11 117		
dprime	0.92	1.65	1.87	2.37		
bias	0.07	0.15	0.09	0.31		
JND = 56.1% , 0.28mm						

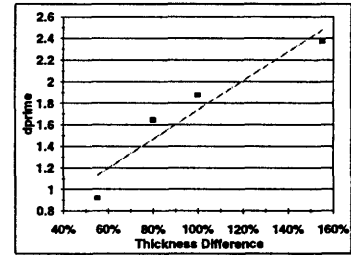

Session 8 Steel Plates Reference thickness = 0.25 mm						
thickness difference	0.25mm 100%	0.375mm 150%	0.525mm 210%	0.65mm 260%		
confusion matrix	104 24 32 96	112 16 28 100	116 12 25 103	117 11 16 112		
dprime	1.10	1.36	1.54	1.78		
bias	0.11	0.19	0.23	0.11		
JND = 116.6% , 0.29mm						

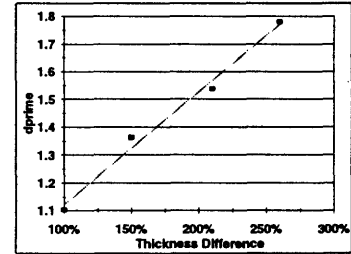

Session 9 Steel Plates Reference thickness = 0.1 mm						
thickness difference	0.05mm 50%	0.1mm 100%	0.15mm 150%	0.275mm 275%		
confusion matrix	87 42 48 80	106 22 26 102	123 7 10 118	126 2 1 127		
dprime	0.54	1.26	2.14	3.23		
bias	0.07	0.06	0.10	-0.13		
JND = 80.8% , 0.08mm						

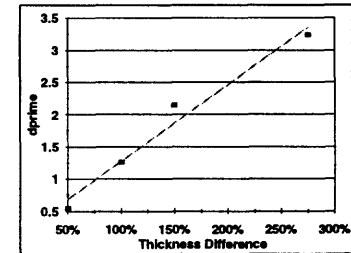

Session 10 Steel Plates Reference thickness = 0.05 mm						
thickness difference	0.025mm 50%	0.05mm 100%	0.075mm 150%	0.15mm 300%		
confusion matrix	81 47 43 85	98 30 20 108	122 6 7 121	127 1 1 127		
dprime	0.54	1.23	2.32	3.42		
bias	-0.04	-0.14	0.04	0.0		
JND = 80.2% , 0.04mm						

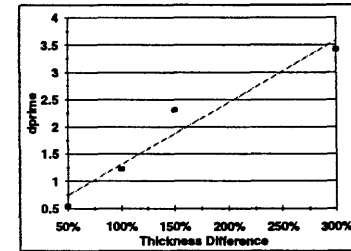

A.5 Subject: S5

Session 1 Plastic Plates Reference thickness = 10.0 mm				
thickness difference	0.25mm 2.5%	0.5mm 5%	1mm 10%	1.5mm 15%
confusion matrix	94 45 24 104	105 23 27 101	107 21 14 114	123 5 4 124
dprime	0.95	1.22	1.56	2.56
bias	-0.21	0.06	-0.13	-0.05
JND = 4.2% , 0.42mm				

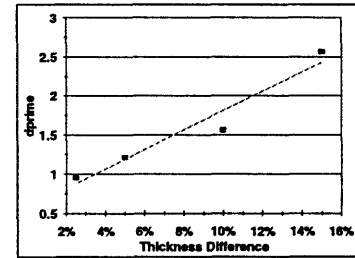

Session 2 Plastic Plates Reference thickness = 5.0 mm				
thickness difference	0.25mm 5%	0.5mm 10%	0.75mm 15%	1mm 20%
confusion matrix	84 45 46 82	92 36 30 98	106 22 10 118	109 19 8 120
dprime	0.53	0.92	1.67	1.82
bias	0.01	-0.07	-0.24	-0.25
JND = 10.0% , 0.5mm				

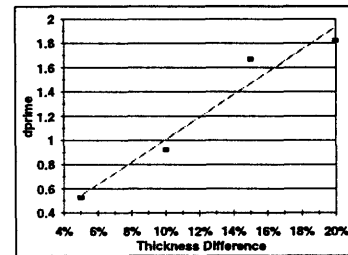

Session 3 Plastic Plates Reference thickness = 2.5 mm				
thickness difference	0.25mm 10%	0.5mm 20%	0.75mm 30%	1mm 40%
confusion matrix	84 44 47 81	102 26 36 92	121 7 20 108	114 14 11 117
dprime	0.52	1.00	1.85	1.84
bias	0.03	0.13	0.30	-0.07
JND = 19.1% , 0.48mm				

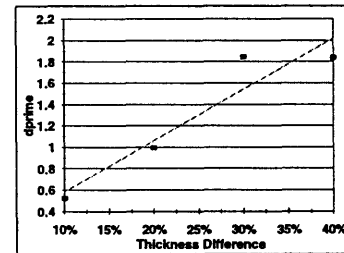

Session 4 Plastic Plates Reference thickness = 1.0 mm				
thickness difference	0.3mm 30%	0.5mm 50%	0.7mm 70%	0.85mm 85%
confusion matrix	97 31 30 98	111 17 28 100	112 16 21 107	114 14 17 111
dprime	1.01	1.33	1.50	1.66
bias	-0.01	0.17	0.09	0.06
JND = 39.5% , 0.40mm				

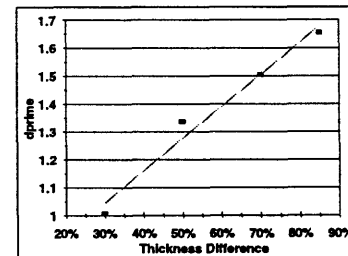

Session 5 Plastic Plates Reference thickness = 0.5 mm				
thickness difference	0.15mm 30%	0.25mm 50%	0.5mm 100%	0.8mm 160%
confusion matrix	88 40 35 93	102 26 21 107	117 11 8 120	124 4 2 126
dprime	0.77	1.28	2.05	2.84
bias	-0.06	-0.07	-0.08	-0.15
JND = 72.4% , 0.36mm				

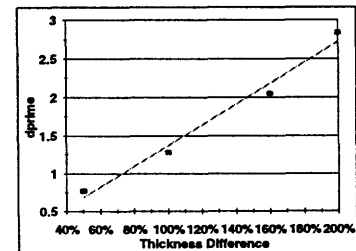

Session 6 Plastic Plates Reference thickness = 0.25 mm				
thickness difference	0.05mm 20%	0.1mm 40%	0.25mm 100%	0.35mm 140%
confusion matrix	93 35 27 101	113 15 22 106	125 5 1 127	126 2 0 128
dprime	0.99	1.51	2.96	3.4
bias	-0.10	0.12	-0.32	-0.25
JND = 28.3% , 0.07mm				

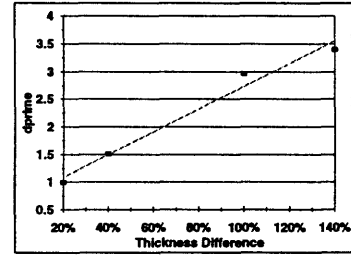

Session 7 Steel Plates Reference thickness = 0.5 mm				
thickness difference	0.275mm 55%	0.4mm 80%	0.5mm 100%	0.775mm 155%
confusion matrix	80 18 42 86	88 10 22 106	98 30 20 108	107 21 16 112
dprime	0.54	1.01	1.23	1.50
bias	-0.06	-0.23	-0.14	-0.09
JND = 90.0% , 0.45mm				

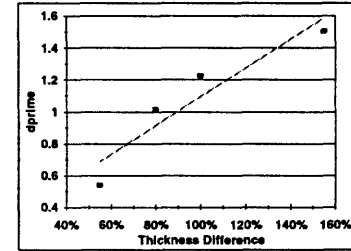

Session 8 Steel Plates Reference thickness = 0.25 mm				
thickness difference	0.375mm 150%	0.525mm 210%	0.65mm 260%	0.75mm 300%
confusion matrix	91 37 25 103	101 27 21 107	112 16 10 118	114 14 9 119
dprime	1.00	1.26	1.82	1.91
bias	-0.15	-0.09	-0.13	-0.12
JND = 153.7% , 0.38mm				

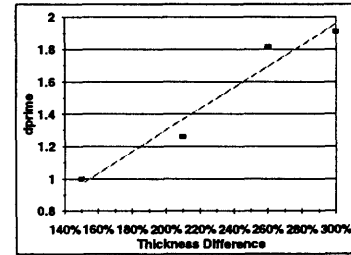

Session 9 Steel Plates Reference thickness = 0.1 mm				
thickness difference	0.025mm 25%	0.1mm 100%	0.15mm 150%	0.2mm 200%
confusion matrix	79 49 42 86	107 21 28 100	116 12 9 119	123 5 2 124
dprime	0.52	1.24	1.97	2.76
bias	-0.07	0.10	-0.08	-0.19
JND = 66.2% , 0.07mm				

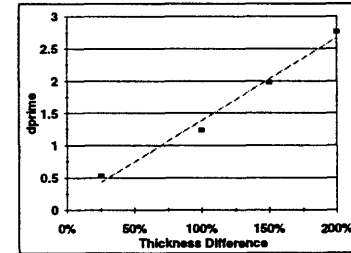

Session 10 Steel Plates Reference thickness = 0.05 mm				
thickness difference	0.025mm 50%	0.05mm 100%	0.075mm 150%	0.15mm 300%
confusion matrix	89 39 28 100	114 14 12 116	118 10 10 118	127 1 1 127
dprime	0.91	1.80	2.01	3.42
bias	-0.13	-0.04	0.0	0.0
JND = 65.6% , 0.03mm				

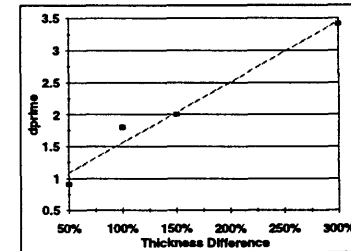

Appendix B: Computation of dprime (d') and bias (β)

The purpose here is to introduce the algorithm about how to calculate dprime (d') and bias (β). The following notes are based on [Durlach et al, 1968]. (Readers interested in knowing more about the details are encouraged to read this reference.)

A two-interval two-alternative-forced choice (2I-2AFC) experiment is the one in which:

- There are two admissible signal sources, S_1 and S_2 , and two admissible presentations, $U_1=(S_2,S_1)$ and $U_2=(S_1,S_2)$, each of which is a temporally-ordered pair.
- There are two admissible responses, R_1 and R_2 .
- On each trial, the experimenter presents U_1 or U_2 randomly with a priori probabilities $P(U_1) = P(U_2) = 0.5$.
- The subject is instructed to respond R_1 when U_1 is perceived to be presented and R_2 when U_2 is perceived to be presented.

A confusion matrix is used to record the experimental results:

	R1	R2
U1	f11	f12
U2	f21	f22

$$f_{ji} = N (R_i | U_j) / [N (R_1 | U_j) + N (R_2 | U_j)] \text{----- (B.1)}$$

where $N(R_i|U_j)$ is the number of times the subject responded R_i to U_j ; therefore, $f_{j1}+f_{j2}=1$.

Furthermore, $N(R_1|U_1) + N(R_2|U_1) = N(R_1|U_2) + N(R_2|U_2)$ since $P(U_1) = P(U_2) = 0.5$.

From equation B.2 to B.4, two variables, Z_d and Z_f , can be calculated.

$$P(X) = \frac{1}{\sqrt{2\pi}} e^{-\frac{x^2}{2}} \text{----- (B.2)}$$

$$f_{12} = \int_{-\infty}^{z_f} P(X) dX \text{----- (B.3)}$$

$$f_{22} = \int_{-\infty}^{z_d} P(X) dX \text{----- (B.4)}$$

After getting the values of Z_d and Z_f , the d' and bias (β) could be calculated from the equations B.5 and B.6.

$$d' = Z_d - Z_f \text{----- (B.5)}$$

$$\beta = -\frac{Z_d + Z_f}{2} \text{----- (B.6)}$$

Appendix C

Program for stimulus presentation using a stepper motor

```
/* Original version written by Kevin Knoedler, May 93 and Ashanthi Gajaweera, May 94.*/
/*Substantially revised by Chih-Hao Ho, March 95*/
#include<stdio.h>
#include<stdlib.h>
#include<dos.h>
#include<time.h>
#define TESTSIZE 128
#define CCW 0
#define CW 1
int position=1; /* global variable that tracks the motors position */
                /* It is critical to ensure that this represents the real position of the motor. */
                /* Delay is an integer that is counted off between each step. This value will be diffeent
                for different computer.*/
int trial=0; /*global variable that counts trials per run*/
void moveto(int temp_position); /* goes to a specific position */
void stepcw(void); /* takes a single step clockwise */
void stepccw(void); /* takes a single step CCW */
void move(int direction, int steps); /* goes the specified number of steps
                                     in the proper direction using delay*/

void clean_screen(void);
int second_rotate(void);
void decelerate(int direction);

struct data /* This contains the major data. I used it as a global variable to simplify coding */
{
    char *initials;
    int session;
    int run;
    char *date;
    char hand;
    char sex;
    int age;
    char *start;
    char *end;
    char *protocol;
    int size;
    int *dat;
} data;
void mainmenu(void); /* main menu, no effects */
void savedata(int try); /* writes file based on data */
void makefilename(int try, char *filename); /* creates filename */
void instructions(void); /* instructions for the subject */
void runtest(void); /* runs the actual test */
void results(void); /* displays the results */
void fixdate(char *d); /* formats the date */
void fixtime(char *t); /* formats the time */
```

```

void getinitials(void);                /* inputs the users initials */
int randompresent(void);              /* presents slides and collects data; no feedback*/

void main(void)
{
    data.initials="____"; /* initialize data structure */
    data.session=1000;
    data.run=1000;
    data.date="00-00-00";
    data.hand='y';
    data.sex='r';
    data.age=200;
    data.start="00:00";
    data.end="00:00";
    data.protocol="formal-test, 2 pairs, no feedback, thickness";
    data.size=0;
    mainmenu();
}

void mainmenu(void)
{ int a;
  clean_screen();
  printf("  Thickness Discrimination Main Menu\n\n\n\n");
  printf("    1. Instructions\n\n\n");
  printf("    2. Run Test\n\n\n");
  printf("    3. View Results\n\n\n");
  printf("    4. Exit\n\n\n");
  printf("    What is your choice? (1,2,3 or 4)\n\n\n\n ");
  a=getche();
  if (a=='1') instructions();
  if (a=='2') runtest();
  if (a=='3') results();
  if (a=='4') exit(1);
  mainmenu();
}

void instructions(void)
{ int a, ch;
  FILE *fp1;
  clean_screen();
  fp1=fopen("instruct.doc","r");
  ch=getc(fp1);
  while (ch != EOF){
      printf("%c",ch);
      ch=getc(fp1);
  }

  fclose(fp1);
  printf("\nPress any character to return to the main menu\n");
  a=getche();
}

void runtest(void)
{

```

```

int a, b, c; /* inputs user data and calls test procedure */
clean_screen();
printf("Please check the file -protocol.doc- to see if it is correct.");
printf("\n\nPlease check the date and the time first.\n\n\n");
printf("Do you want to quit now? y/n");
a=getche();
while (a!='y' && a!='n') a=getche();
if (a=='y') return;
fixdate(data.date);
fixtime(data.start);
getinitials();
printf("\nWhat session number is this? ");
scanf("%d", &data.session);
printf("\nWhat run number is this? ");
scanf("%d", &data.run);
printf("\nAge? ");
scanf("%d", &data.age);
printf("\nSex? m or f ");
b=0;
while ((b!='m') && (b!='f')) b=getche();
data.sex=b;
printf("\n\nWhich hand will you be using? r or l ");
while ((a!='l')&&(a!='r')) a=getche();
data.hand=a;
data.size=TESTSIZE;
printf("\n\nPress 's' to start over, any other key to begin. ");
a=getche();
if (a=='s') runttest();
else
{
printf("\n\nHave you made sure the plates are in the");
printf("\nright starting position? y/n");
b=0;
while (b!='y') b=getche();
trial=1;
a=randompresent();
fixtime(data.end);
savedata(0);
}
}

void results(void)
{
int a,b, a00, a01, a10, a11, cnt; /* prints data to screen */
b=0; a00=0; a01=0; a10=0; a11=0;
clean_screen();
printf(" Data\n\n\n");
printf("initials %s\n", data.initials);
printf("session number %d\n", data.session);
printf("run number %d\n", data.run);
printf("date %s\n", data.date);
printf("hand used %c\n", data.hand);
printf("sex %c\n", data.sex);

```

```

printf("age %d\n", data.age);
printf("start time %s\n", data.start);
printf("end time %s\n", data.end);
printf("protocol %s\n", data.protocol);
printf("data size %d\n", data.size);
cnt=0;
while (cnt<data.size)
{
    b=data.dat[cnt];
    while (b>1) b=b-2;
    if ((b==1) && (data.dat[cnt+1]==0)) a00++;
    if ((b==1) && (data.dat[cnt+1]==1)) a01++;
    if ((b==0) && (data.dat[cnt+1]==0)) a10++;
    if ((b==0) && (data.dat[cnt+1]==1)) a11++;
    cnt=cnt+2;
}
printf("\n\nchose 1 2\n\n");
printf("given 1 %3d %3d\n", a00, a01);
printf("given 2 %3d %3d\n", a10, a11);
printf("\n\nPress any key to return to the main menu");
a=getche();
}

```

```

void savedata( int try) /* Checks to ensure file doesn't exist.
                        If file exists it increments the month by 12.
                        Try is used to keep track of the # of attempts*/
{
    int cnt,d, a00, a01, a10, a11;
    char *filename, ch;
    FILE *fp,*fp2;
    a00=0; a01=0; a10=0; a11=0;
    filename="12345678.dat";
    makefilename(try, filename);
    fp=fopen(filename, "r");
    if (fp==NULL)
    {
        fclose(fp);
        fp=fopen(filename, "wt");
        fp2=fopen("protocol.doc","r");
        if (fp==NULL) printf("Failure saving file, copy data by hand. \n");
        ch=getc(fp2);
        while (ch!=EOF){
            putc(ch,fp);
            ch=getc(fp2);
        }
        fprintf(fp, "\ninitials %s\n", data.initials);
        fprintf(fp, "session number %d\n", data.session);
        fprintf(fp, "run number %d\n", data.run);
        fprintf(fp, "date %s\n", data.date);
        fprintf(fp, "hand used %c\n", data.hand);
        fprintf(fp, "sex %c\n", data.sex);
        fprintf(fp, "age %d\n", data.age);
        fprintf(fp, "start time %s\n", data.start);
    }
}

```

```

fprintf(fp, "end time %s\n", data.end);
fprintf(fp, "protocol %s\n", data.protocol);
fprintf(fp, "data size %d\n", data.size);
cnt=0;
while (cnt<data.size)
{
d=data.dat[cnt];
while (d>1) d=d-2;
if ((d==1) && (data.dat[cnt+1]==0)) a00++;
if ((d==1) && (data.dat[cnt+1]==1)) a01++;
if ((d==0) && (data.dat[cnt+1]==0)) a10++;
if ((d==0) && (data.dat[cnt+1]==1)) a11++;
cnt=cnt+2;
}
fprintf(fp, "\n\nchose 1 2\n\n");
fprintf(fp, "given 1 %3d %3d\n", a00, a01);
fprintf(fp, "given 2 %3d %3d\n\n", a10, a11);
cnt=0;
while (cnt<data.size)
{
fprintf(fp, "%3d %d %d\n", (cnt/2)+1, data.dat[cnt], data.dat[cnt+1]);
cnt=cnt+2;
}
fclose(fp);
fclose(fp2);
}
else
{
printf("error--file already exists, retrying with different name");
savedata( try+1);
}
}

```

```

void makefilename( int try, char *filename)
{
/* Construction of a filename */
/* First three characters=initials */
/* 4th character=month encoded as 1-9 and A-Z */
/* 5th character=day encoded as 1-9 and A-Z */
/* 6th character=finish hour encoded as 1-9 and A-Z */
/* 7th and 8th character=finish minutes */
char m,d , t1, t2, t3;
int a,b,c;
m=(((*data.date)-'0')*10)+((*data.date+1))+try*12;
d=(((*data.date+3))-'0')*10)+((*data.date+4));
t3=*(data.end+4);
t2=*(data.end+3);
t1=*(data.end+1)+10*((*data.end)-'0');
if (m>57) m=m+7;
if (d>57) d=d+7;
if (t1>57) t1=t1+7;
*(filename)=*(data.initials);
*(filename+1)=*(data.initials+1);
}

```

```

*(filename+2)=*(data.initials+2);
*(filename+3)=m;
*(filename+4)=d;
*(filename+5)=t1;
*(filename+6)=t2;
*(filename+7)=t3;
}

void fixdate(char *d)
{
    time_t lt;
    char *timestring, *month;
    month=" ";
    lt=time(NULL);
    timestring=ctime(&lt);
    *(month+0)=*(timestring+4);
    *(month+1)=*(timestring+5);
    *(month+2)=*(timestring+6);
    printf("%s", month);
    *(d+3)=*(timestring+8);
    *(d+4)=*(timestring+9);
    *(d+6)=*(timestring+22);
    *(d+7)=*(timestring+23);
    if (!strcmp(month, "Jan")) {*(d+0)='0';*(d+1)='1';}
    else if (!strcmp(month, "Feb")) {*(d+0)='0';*(d+1)='2';}
    else if (!strcmp(month, "Mar")) {*(d+0)='0';*(d+1)='3';}
    else if (!strcmp(month, "Apr")) {*(d+0)='0';*(d+1)='4';}
    else if (!strcmp(month, "May")) {*(d+0)='0';*(d+1)='5';}
    else if (!strcmp(month, "Jun")) {*(d+0)='0';*(d+1)='6';}
    else if (!strcmp(month, "Jul")) {*(d+0)='0';*(d+1)='7';}
    else if (!strcmp(month, "Aug")) {*(d+0)='0';*(d+1)='8';}
    else if (!strcmp(month, "Sep")) {*(d+0)='0';*(d+1)='9';}
    else if (!strcmp(month, "Oct")) {*(d+0)='1';*(d+1)='0';}
    else if (!strcmp(month, "Nov")) {*(d+0)='1';*(d+1)='1';}
    else if (!strcmp(month, "Dec")) {*(d+0)='1';*(d+1)='2';}
}

void fixtime(char *t)
{
    char *timestring;
    time_t lt;
    lt=time(NULL);
    timestring=ctime(&lt);
    *(t+0)=*(timestring+11);
    *(t+1)=*(timestring+12);
    *(t+3)=*(timestring+14);
    *(t+4)=*(timestring+15);
}

void getinitials(void)
{
    char *ini; int a;
    clean_screen();
}

```

```

printf("Please input your initials ");
scanf ("%s", ini);
a=strlen(ini);
if (a==2)
{
*(data.initials+0)=*(ini);
*(data.initials+1)=*(ini+1);
*(data.initials+2)='_';
*(data.initials+3)='_';
}
else if (a==1)
{
*data.initials=*ini;
*(data.initials+1)='_';
*(data.initials+2)='_';
*(data.initials+3)='_';
}
else if (a==0);
else if (a==3)
{
*(data.initials+0)=*(ini);
*(data.initials+1)=*(ini+1);
*(data.initials+2)=*(ini+2);
*(data.initials+3)='_';
}
else
{
*(data.initials+0)=*(ini);
*(data.initials+1)=*(ini+1);
*(data.initials+2)=*(ini+2);
*(data.initials+3)=*(ini+3);
}
}

int randompresent(void)
{
int a,b,c,d,p,t;
randomize();
data.dat=malloc(TESTSIZE*sizeof(int));
a=0;
while (a<TESTSIZE) {data.dat[a]=-1; a++;}
clean_screen();
printf("Ensure that your fingers and thumb are clear each time.\n");
printf("At any point, press x to end the trial and return to the\n");
printf("main menu.\n");
printf("\n\n\n\n\n\n\n\nWhich pair to test? (1 or 2):");
scanf("%d", &t);
while(t!=1 && t!=2) {
printf("\nPlease input 1 or 2 :");
scanf("%d", &t);
}
t=t*4;
printf("Press any key to start the motor.\n");

```

```

a=getche();
if (a=='x') return(-1);
printf("\n");
b=0; randomize();
c=0;d=0;
while (b<TESTSIZE)
  { if (c<32 && d<32) {
      p=random(4);
      if (p%2) c++; else d++;
    }
    else { if(c==32) { p=random(2);p=p*2; d++;}
          else { p=random(2);p=p*2+1; c++;}
    }
    moveto(t-p);
    data.dat[b]=second_rotate();
    if (data.dat[b]==-1) return(-1);
    printf("\nHere is plate 2.");
    printf("\nWhich was thicker? The first plate or the second? 1 or 2 : ");
    a=0;
    while ((a!='1')&&(a!='2')&&(a!='x')) a=getche();
    if (a=='x') return(-1);
    b++;
    data.dat[b]=a-'1';
    b++;
    trial++;
  } /* end of b loop */
moveto(1);
return(1);
}

void stepccw(void)
{
  outport(0x3bc, 1);
  outport(0x3bc, 0);
}

void stepcw(void)
{
  outport(0x3bc, 3);
  outport(0x3bc, 2);
}

void move(int direction, int steps)
{
  while(steps>50)
  {int delay=4000;
  steps--;
  if (direction==CCW) stepccw(); else stepcw();
  while(delay>0) delay--;
  };
  if (steps) decelerate(direction);
  else move(0,400);
}

```

```

void moveto(int temp_position)
{
    int direction, steps;
    if (temp_position > position)
        { if (temp_position - position < 4)
            {direction = 1; steps = 50 * (temp_position - position);}
          else {direction = 0; steps = 50 * (8 + position - temp_position);}
        }
    else
        { if (position - temp_position > 4)
            {direction = 1; steps = 50 * (8 + temp_position - position);}
          else {direction = 0; steps = 50 * (position - temp_position);}
        }
    move (direction, steps);
    position = temp_position;
}

```

```

int second_rotate(void)
{
    int a,p,c,d=0;
    clean_screen();
    printf("\nHere is plate 1");
    printf("\nPress any key for the next sample.");
    a=getch();
    if (a=='x') return(-1);
    p=position;
    c=p;
    if (c>4) {c=c-4;d=4;}
    a=random(2);a=a*2-1;
    c=c+a;
    if(c>4) c=c-4;
    if(c<1) c=c+4;
    moveto(c+d);
    return(p);
}

```

```

void decelerate(int direction)
{
    int a, b;
    a=50;
    while (a>30)
        {
            a--;
            if (direction==CW) stepcw(); else stepccw();
            b=4500;
            while (b>0) b--;
        }
    while (a>20)
        {
            a--;
            if (direction==CW) stepcw(); else stepccw();
            b=5000;
        }
}

```

```
    while(b>0) b--;
  }
  while (a>0)
  {
    a--;
    if (direction==CW) stepcw(); else stepccw();
    b=6000;
    while(b>0) b--;
  }
}

void clean_screen(void){
  int a=0;
  while (a<26) {printf("\n"); a++;}
}
```

Appendix D

Input file for the finite element analysis of the plates using ABAQUS

*HEADING

PLATE DEFORMATION ANALYSIS - three dimensional elements

*NODE

1,0.,25.

5,0.,50.

13,50.,50.

21,50.,0.

29,0.,0.

33,0.,25.

201,6.,25.

217,44.,25.

233,6.,25.

451, 20.2377, 25.0000

452, 20.2898, 25.9369

453, 20.4521, 26.8838

454, 20.7424, 27.8448

455, 21.1902, 28.8098

456, 21.8321, 29.7411

457, 22.6976, 30.5584

458, 23.7792, 31.1376

459, 25.0000, 31.3497

466, 29.7102, 25.9369

465, 29.5479, 26.8838

464, 29.2576, 27.8448

463, 28.8098, 28.8098

462, 28.1679, 29.7411

461, 27.3024, 30.5584

460, 26.2208, 31.1376

483, 20.2377, 25.0000

551, 20.7686, 25.0000

552, 20.8149, 25.8325

553, 20.9591, 26.6738

554, 21.2170, 27.5277

555, 21.6149, 28.3851

556, 22.1852, 29.2126

557, 22.9543, 29.9387

558, 23.9153, 30.4534

559, 25.0000, 30.6419

566, 29.1851, 25.8325
 565, 29.0409, 26.6738
 564, 28.7830, 27.5277
 563, 28.3851, 28.3851
 562, 27.8148, 29.2126
 561, 27.0457, 29.9387
 560, 26.0847, 30.4534
 583, 20.7686, 25.0000
 951,25.,25.
 983,25.,25.
 *NGEN,NSET=EDGE01
 1,5
 5,13
 13,21
 21,29
 29,33
 *NGEN,NSET=TIP
 951,983
 *NGEN,NSET=EDGE02,LINE=C
 201,217,1,951,25.,25.,0.,0.,0.,-1.
 217,233,1,951,25.,25.,0.,0.,0.,-1.
 *NSET,NSET=EDGE03-01,GENERATE
 451,466,1
 *NSET,NSET=EDGE04-01,GENERATE
 551,566,1
 *NCOPY,CHANGE NUMBER=16,OLD SET=EDGE03-01,REFLECT=POINT
 25.,25.,0.
 *NSET,NSET=EDGE03,GENERATE
 451,483,1
 *NCOPY,CHANGE NUMBER=16,OLD SET=EDGE04-01,REFLECT=POINT
 25.,25.,0.
 *NSET,NSET=EDGE04,GENERATE
 551,583,1
 *NFILL,NSET=ALL-01
 EDGE01,EDGE02,4,50
 *NFILL,NSET=ALL-02
 EDGE02,EDGE03,5,50
 *NFILL,NSET=ALL-03
 EDGE03,EDGE04,2,50
 *NFILL,NSET=ALL-04,SINGULAR=2
 EDGE04,TIP,8,50
 *NSET,NSET=ALL
 ALL-01,ALL-02,ALL-03,ALL-04
 *NCOPY,CHANGE NUMBER=1000,OLD SET=ALL,SHIFT
 0.,0.,0.05

0.,0.,-1.,0.,0.,1.,0.
 *NCPY,CHANGE NUMBER=2000,OLD SET=ALL-01,SHIFT
 0.,0.,0.86
 0.,0.,-1.,0.,0.,1.,0.
 *NCPY,CHANGE NUMBER=3000,OLD SET=ALL-01,SHIFT
 0.,0.,-0.81
 0.,0.,-1.,0.,0.,1.,0.
 *ELEMENT,TYPE=C3D8
 1,1,51,52,2,1001,1051,1052,1002
 32,32,82,51,1,1032,1082,1051,1001
 *ELGEN
 1,31,1,1,18,50,32
 32,18,50,32
 *ELEMENT,TYPE=C3D8
 577,901,951,903,902,1901,1951,1903,1902
 578,903,951,905,904,1903,1951,1905,1904
 579,905,951,907,906,1905,1951,1907,1906
 580,907,951,909,908,1907,1951,1909,1908
 581,909,951,911,910,1909,1951,1911,1910
 582,911,951,913,912,1911,1951,1913,1912
 583,913,951,915,914,1913,1951,1915,1914
 584,915,951,917,916,1915,1951,1917,1916
 585,917,951,919,918,1917,1951,1919,1918
 586,919,951,921,920,1919,1951,1921,1920
 587,921,951,923,922,1921,1951,1923,1922
 588,923,951,925,924,1923,1951,1925,1924
 589,925,951,927,926,1925,1951,1927,1926
 590,927,951,929,928,1927,1951,1929,1928
 591,929,951,931,930,1929,1951,1931,1930
 592,931,951,901,932,1931,1951,1901,1932
 *ELEMENT,TYPE=C3D8
 1001,1001,1051,1052,1002,2001,2051,2052,2002
 2001,3001,3051,3052,3002,1,51,52,2
 1032,1032,1082,1051,1001,2032,2082,2051,2001
 2032,3032,3082,3051,3001,32,82,51,1
 *ELGEN
 1001,31,1,1,4,50,32
 2001,31,1,1,4,50,32
 1032,4,50,32
 2032,4,50,32
 *ELSET,ELSET=STEEL,GENERATE
 1,592,1
 *ELSET,ELSET=UPALUM,GENERATE
 1001,1128,1
 *ELSET,ELSET=DOWNALUM,GENERATE

2001,2128,1
*ELSET,ELSET=THUMB,GENERATE
289,592,1
*ELSET,ELSET=INDEX,GENERATE
353,592,1
*ELSET,ELSET=ALUMINUM
UPALUM,DOWNALUM
*SOLID SECTION,ELSET=STEEL,MATERIAL=STEEL
*SOLID SECTION,ELSET=ALUMINUM,MATERIAL=ALUMINUM
*MATERIAL,NAME=STEEL
*ELASTIC
190295,0.305
*MATERIAL,NAME=ALUMINUM
*ELASTIC
68948,0.33
*NSET,NSET=FIXED,GENERATE
23,27,1
73,77,1
123,127,1
1023,1027,1
1073,1077,1
1123,1127,1
2023,2027,1
2073,2077,1
2123,2127,1
3023,3027,1
3073,3077,1
3123,3127,1
*NSET,NSET=DIAMETER,GENERATE
9,909,50
951,951,1
925,25,-50
*BOUNDARY
FIXED,ENCASTRE
*STEP
*STATIC
*DLOAD
THUMB,P1,0.0032
INDEX,P2,0.0041
*NODE PRINT,NSET=DIAMETER
U
RF
*NODE FILE,NSET=DIAMETER
U,RF
*RESTART,WRITE

*END STEP

Bibliography

1. Brown, R., Galanter, E., Hess, E.H., and Mandler, G., "New Directions in Psychology I". Holt, Rinehart and Winston, Inc., 1962.
2. Durlach, N.I., "A Decision Model for Psychophysics". Unpublished manuscript available at CBG, RLE, MIT, 1968.
3. Durlach, N.I., Delhorne, L.A., Wong, A., Ko, W.Y., Rabinowitz, W.M., and Hollerbach, J., "Manual discrimination and identification of length by the finger-span method". *Perception & Psychophysics*, 1989, 46 (1), 29-38.
4. John, K.T., Goodwin, A.W., and Darian-Smith, I., "Tactual Discrimination of Thickness". *Experimental Brain Research*, 1989, Vol. 78, No. 1, pp. 62-68.
5. Gajaweera, A., "Tactual Discrimination of Thickness". Bachelor's Thesis, ME, MIT, May 1994.
6. Garner, W.R., "Uncertainty and Structure as Psychological Concepts". John Wiley and Sons, Inc., New York, 1962.
7. Goodwin, A.W., John, K.T., and Marceglia, A.H., "Tactual Discrimination of Curvature by humans using only cutaneous information from the fingertips". *Experimental Brain Research*, 1991, 86:663-672.
8. Loomis, J.M., and Lederman, S.J., "Tactual Perception, In: Handbook of Perception and Human Performance". John Wiley and Sons, New York, 1986.
9. Macmillan, M.A., and Creelman, C.D., "Detection Theory: A User's Guide". Cambridge University press, 1991.
10. Srinivasan, M.A., "The human haptic system". Unpublished manuscript available at CBG, RLE, MIT.
11. Srinivasan, M.A., and LaMotte, R.H., "Encoding of shape in the responses of cutaneous mechanoreceptors in information processing in the somatosensory System". *Wenner-Gren Intl. Symposium Series*, Macmillan Press, 1991.
12. Srinivasan, M.A., and LaMotte, R.H., "Tactual Discrimination of softness". *J. Neurophysiology*, vol. 73, No. 1, pp.88-101, 1995.
13. Srinivasan, M.A., Whitehouse, J.M., and LaMotte, R.H., "Tactile detection of slip: Surface microgeometry and peripheral neural codes". *J. Neurophysiology*, vol. 63,

No.6, pp.1323-1332, 1990.

14. Tan, H.Z., "Analysis of Synthetic Tahoma System as a Multidimensional Tactile Display". Master's Thesis, EECS, MIT, May 1988.
15. Tan, H.Z., Pang, X.D., and Durlach, N.I., "Manual Resolution of Length, Force, and Compliance". Winter Annual Meeting of the American Society of Mechanical Engineers: Advances in Robotics, 1992, 42, 13-18.
16. Tan, H.Z., and Srinivasan, M.A., "Discrimination and Identification of Finger Joint Angle Position Using Active Finger Motion". manuscript preparation, 1996.
17. Tan, H.Z., Srinivasan, M.A., Eberman, B., and Cheng, B., "Human factors for the design of force-reflecting haptic interfaces". The American Society of Mechanical Engineers, 1994, Vol. 55-1, 353-359.

