

IMAGE OF THE WORK ENVIRONMENT:
DESIGN OF OFFICE SPACE

by

JOHN SUK JUN BURKE

B.A., University of California, Berkeley
1975

SUBMITTED IN PARTIAL FULFILLMENT OF THE REQUIREMENTS
FOR THE DEGREE OF MASTER OF ARCHITECTURE
AT THE

MASSACHUSETTS INSTITUTE OF TECHNOLOGY

Signature of Author _____

Department of Architecture, May 8, 1979

Certified by _____

Julian Beardart, Professor of Architecture

Accepted by _____

Imre Halasz, Chairman
Departmental Committee for Graduate Students

Roche Copyright © J.S.J. Burke 1979

MASSACHUSETTS INSTITUTE
OF TECHNOLOGY

AUG 14 1979

LIBRARIES

ABSTRACT

IMAGE OF THE WORKING ENVIRONMENT: DESIGN OF OFFICE SPACE

SUBMITTED TO THE DEPARTMENT OF ARCHITECTURE ON 8 MAY 1979 IN PARTIAL FULFILLMENT OF THE REQUIREMENTS FOR THE DEGREE OF MASTER OF ARCHITECTURE

The intention of this thesis is to analyze office workers' attitudes toward and images of the design ramifications of their working environment; the physical definition of workers' perceptions in manipulating their space; and the relationship between public and private space within the work environment.

The task of assessing a successful work environment is complicated by political, social, historical, and economic implications. Because the work environment often reflects the larger social structure, it is imperative to acknowledge its influence and to address it in terms of the design process of the work place.

Initially, I researched the historical aspects of the work environment, the development of the office, and the political and economic roles

concerning management. The main issues to be evaluated are the problems people confront at work; the worker's conception of private space, public realm, territoriality, and hierarchy in the work environment; and, how these issues are reflected in the work environment.

Through field work documentation of a place and its people and through personal conversations, attitudes, preferences and priorities involved in physically defining the work environment evolved. Thus, field trips were visualized as a vehicle for the design process or as another type of design tool for the architect. Through this exploration, it was hoped that working places would reflect the values, goals, and personal preferences of the people who use them or own them.

The primary purpose of the design segment is to explore and demonstrate the variety of physical implications that are derived from the field work.

THESIS SUPERVISOR: JULIAN BEINART
PROFESSOR OF ARCHITECTURE

ACKNOWLEDGEMENTS

TO DESTINE

Those who have inspired, contributed and helped in this thesis preparation:

- Maurice Smith, Professor of Architecture
Massachusetts Institute of Technology
- Florence Ladd, Assistant Dean, School of Architecture and Urban
Planning
Massachusetts Institute of Technology
- Julian Beinart, Professor of Architecture
Massachusetts Institute of Technology
- Shun Kanda, Associate Professor of Architecture
Massachusetts Institute of Technology
- Robert Newman, Adjunct Professor of Architecture,
Massachusetts Institute of Technology and
Harvard University
- Dolores Hayden, Professor of Architecture History
University of California at Los Angeles
- Kyu Sung Woo, K.S. Woo and Associates, A.I.A.
Cambridge, Mass.
- Michael Pyatok, Visiting Professor of Architecture
Massachusetts Institute of Technology

Jan Taniguchi, Robert Pena and Frank Miller who have provided moral support and encouragement; Louise McNeely who has been patient and understanding; Jed and Linda Ashley who have contributed to my appreciation of life; Cheryl Simmon who has provided editorial assistance; and finally, to all my architectural predecessors who have made the living environment an enjoyable experience:

Alvar Aalto

H.P. Berlage

Antonio Gaudi

Herman Hertzberger

Lucien Kroll

Charles R. MacKintosh

Frank Lloyd Wright

and

Indigenous Builders

TABLE OF CONTENTS

1. INTRODUCTION
 2. INTERVIEWS
 3. HISTORY
 4. DEFINITION OF WORK
 5. TERRITORIALITY AND PRIVACY
 6. LIGHTING
 7. NOISE
 8. PROGRAM
 9. SITE
 10. IMAGES
 11. OPTIONS
 12. DESIGN PROCESS
 13. SUMMARY
- BIBLIOGRAPHY
- APPENDIX - INTERVIEWS

INTRODUCTION

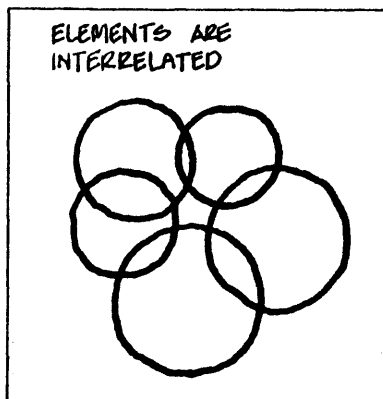

ELEMENTS ARE
INTERRELATED

PLANNING MUST RELATE TO
ALL ELEMENTS

It is desirable, not only for productivity but also for personal satisfaction, that the work environment be varied and stimulating. Thus, a comprehensive analysis of the design process of modern offices would be incomplete without an investigation into the social, political, and behavioral phenomena operating within the work environment. A preliminary examination of this thesis attempts to assess the degree to which factors other than physical considerations have entered into the design process of work environment.

The creation of the total environment has traditionally been the architect's job, but it is now such a complex task that in most offices, multidisciplinary design teams are found to be necessary. Decisions which affect the office environment are seldom based upon research findings. This could scarcely be otherwise, for there have been few user-requirement studies of buildings.

This approach is unlikely to change in the immediate future -- because of the nature of their training, most architects will continue to take a fragmented view of the design team's responsibilities. It is my belief that their task, however, is to deal with some parts of the

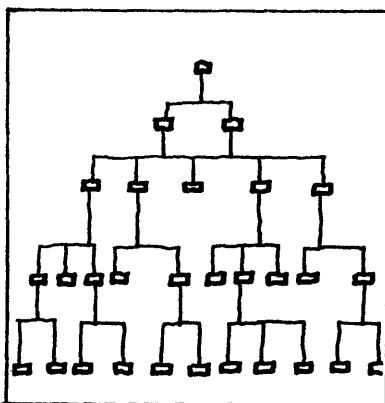

TYPICAL ORGANIZATIONAL CHART

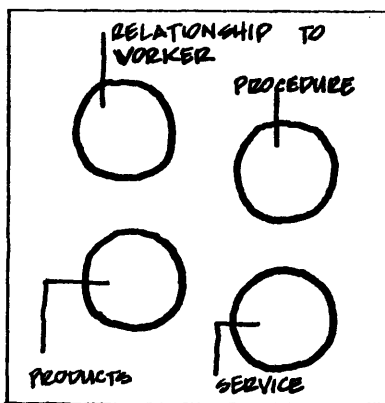

ORGANIZATION

social, behavioral problems, rather than leaving this area to their specialist consultants. Management consultants and office planning firms tend to concentrate on organizational behavior and organizational development and are likely to display a lack of interest in the total environment. Rather they tend to interpret their responsibilities narrowly, concerning themselves solely with the electric lighting design or the thermal environment. They work more comfortably in terms of a particular organization or what the language may suggest about the organization's physical definition and dimensions. The social consequences resulting from the design of office space have been minimally questioned. Questions about human activity are rarely asked. It is usually assumed that those questions have been satisfactorily answered.

The office landscape concept is a relatively new approach to office planning. Consequently, there is a general lack of knowledge about it. As an initial step in evaluating a particular work environment, it is necessary to know the purpose of the office and who will be working in it. Pertinent questions are: is the office functionally efficient, does it provide pleasant working surroundings, and does it preserve the physical exterior and interior conditions? If these criteria are not

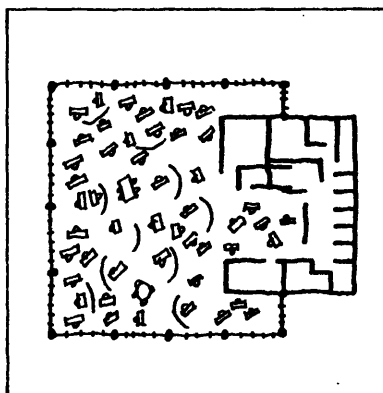
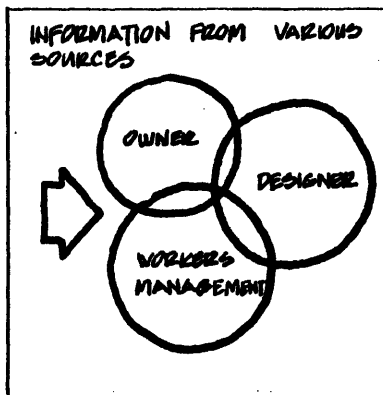

DU PONT OFFICE SPACE

met, the fault is not the architect's alone, for when she/he designs the building, the users are frequently unknown and the offices are sometimes not used for the intended purpose. Moreover, there is inadequate feedback to the architect about the performance of her/his building.

Office work presents a dilemma in the search for the meaning of work, since it is alienated from the process of production. Office work is one step removed from physical labor. Workers in offices do not have the satisfaction of what blue collar workers call useful work. One can walk into any number of large offices and see rows of office workers producing the paper that relates the organization's services and production. The offices usually search for the most efficient method of doing what is to be done. This essentially results in much paperwork, removing most opportunities for workers to see a project through and feel the satisfaction of its completion.

The issues to be addressed are those human needs which should be considered in designing the office building. The categories of behavior which the office program should accommodate

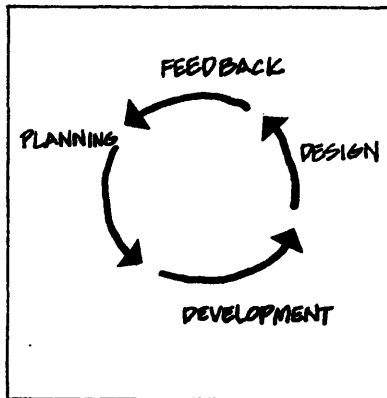

1. SENSE OF BELONGING
2. FLEXIBILITY WITH THE WORKING ENVIRONMENT
3. CHOICE WITHIN THE LARGER REALM
4.

HOME AWAY FROM HOME

must also be examined. These include behavior relating to the organization and to social behavior and to behavior manifested by the individual. Parallel to that is the question of the social and nonsocial. There is a need for the close or intimate scale but also occasionally something larger. There should also be a choice between an active stimulating place and a more quiet, less busy one. As is apparent, a large number of needs span's the spectrum. The object of the problem and its resultant design is the provision of the real range of internal form and definition within which the worker can accomodate his/her needs as far as possible. Finally, one must be able to stop in this place and watch the flow of traffic. These considerations indicate the range of place definitions which the work place should provide.

The working place is associated with the organization body by its visitors and members. As decisions become the concerns of larger numbers of people, these people have to be able to locate one another and exercise their control function. The office is the scene of innumerable interactions and conversations between organization members and visitors. The physical setting inevitably affects, in very basic ways, how people live and work. It can make it easy or difficult to locate people.

Aspects easing use include enough good quality light, reasonable temperature and humidity, and proper levels of sound absorption, diffusion and isolation. There are, however, even more subtle ways in which the office can influence the effectiveness of the organization which it envelopes. A premise of environmental psychology is that the people who work in offices will perform more efficiently if the conditions of the work setting meet their basic needs.

Given the fact of proper light, temperature and sound levels, the characteristics of the physical elements determine a great deal how people will feel. Hard, slick, impervious walls may impose a feeling of isolation and helplessness, since people can in no way use them or change them to suit their needs. The open plan office without any wall definition or just uniform low screening may destroy one's sense of privacy.

Open planners argue for the democratic office environment. In practice, it is no less status conscious than a traditional cubical office.

Employees higher in the company hierarchy are allowed the benefit of more enclosed partitions while low ranking workers occupy space with

1. ECONOMIC
2. EASE OF ARRANGEMENT
3. PAPER FLOW
4. MANAGEMENT

ARGUMENT FOR THE OPEN
PLAN OFFICE

fewer partitions.

The open plan approach was developed in the early 1960's to aid communication and paper flow and to also open up the interior visually. Today, the primary reasons for adopting an open plan are the ease of rearranging offices and the low cost. A reason for the failure of open plan offices is inadequate understanding of the workers' conceptions of their territory and privacy.

These personal and psychological considerations are probably far more important than generally realized and are particularly hard to deal with because they are not as amenable to casting in simple standards as are matters of a simple physical nature such as light level or air temperature. These considerations are usually not foremost in the minds of most designers or planners. Even if they are, it is hard for one person or group to decide the exact kind of place people need to do their job and find satisfaction.

INTERVIEWS

1. LIGHTING: NATURAL AND ARTIFICIAL

Most workers prefer to have natural light provided with a focus light (desk lamp) for the immediate work area. Natural light is insufficient by itself.

Although a majority of workers object to working under fluorescent lights, no specific reasons were given.

2. WINDOW:

Windows provide a light source and visual contact between the inside and outside environment. They provide visual relief for the workers to observe seasonal and weather changes and activities surrounding them.

Most of the workers did not interpret looking outside as a distraction from their work task. Rather, most felt it contributed to their productivity.

Some workers expressed a desire to control their immediate physical surrounding (i.e., having windows which could be opened and desk lamps rather than consistent fluorescent ceiling lights throughout). According to the hierarchy of the office, most window areas are occupied by executives and

managers. Workers were predominantly clustered along the center of the building.

3. COLOR:

Color in the public area (work environment) presented a controversial issue representing personal preferences. Each individual indicated a desire to control their immediate work area with their own choice of color and furniture.

White and light gray present less conflicts and objections. If brighter colors are to be introduced into the office, workers would like to participate in the decision-making process.

4. EATING AREA:

Workers do not like to associate with cafeterias. The 'cafeteria' seems to represent a cold environment, oriented to serving the mass. Workers try to avoid going to the company cafeteria. Several reasons related to this avoidance are bad service, crowding, too large a scale of space and an unrelaxing atmosphere.

Because of the lack of proper space and service, workers generally find themselves eating in their offices or going out to restaurants to avoid the cafeteria environment.

A recommendation interviewees suggested to improve the use of cafeterias was to vary the eating areas and to possibly offer an indoor-outdoor eating space.

5. LOUNGE:

The three offices I visited were all equipped with cooking and refrigerator fixtures. Lounges were located in the center of the building with no light penetration or visual contact to the outdoors. They were used as a part of conferences and the work area. The location of the lounge seems critical to workers. A lounge should be a relaxing place where people can feel free to put their feet up on the table and have a cup of coffee or tea during breaks.

Each office I visited provided lounges, but they were isolated. The location and design of the lounges were given last minute priority in the design criteria.

6. NOISE:

In open plan offices, workers find it difficult to carry out their work task because of noise disturbances. Noise was related to an intrusion of privacy, being heard and hearing other workers' conversations and noise. Workers felt their productivity to be hindered by the distractions surrounding them.

7. WORKING AREA:

Most workers find it difficult to work in large open plan offices.

Partial walls present only temporary fixtures and were thought a danger to the user's work area. They are not usually properly anchored and do not provide sufficient privacy. Workers feel every conversation is overheard and that others passing by can easily look into their domain. Cubical offices present a problem in which social interaction between small and large working areas is blocked. Workers felt cubical offices were too isolated and that it was hard to judge their work/social surroundings in such an environment.

All office managers were located along windows in separate offices.

Workers were generally clustered in the center of a typing pool located in the center of the building. During the interviews, very few complaints were raised by the office managers, but a number of consistent complaints were raised by the lower ranking workers in respect to the inadequacy of the work area.

HISTORY

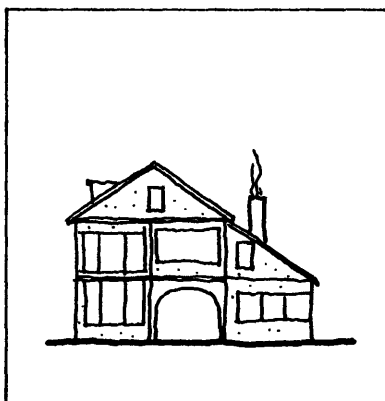

EARLY OFFICE

Historically, the typical office was a room in a house. Eventually it wasn't possible or sensible to live where the office was, and the office remained as a room in a house where no one lived. Such a house was soon filled with offices as the turn of events changed a formerly residential neighborhood into a business neighborhood. An old house serves fairly well as a small office building. It provides a number of small rooms and the necessary services in a way that gives a sense of comfort and informality.

In Chicago it is easy to identify the early buildings constructed solely for office use. They are in the business district and are tall enough to need elevators. The invention of the elevator occurred conveniently early, making this office available when the office buildings began to move into the old business districts where the existing low converted buildings could not keep pace with the demand for office occupancy. Offices appeared in other places as well, in factories and stores, when existing office space became inadequate.

An office was a room and an office building was simply a vast cubical of rooms. When Adler and Sullivan were designing the Schiller Building in

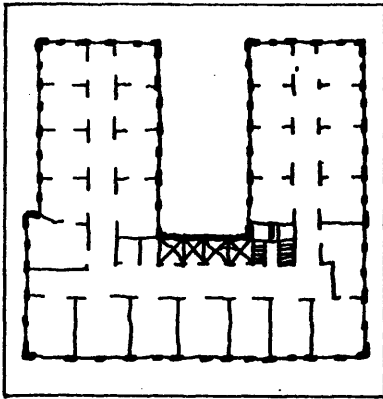

OFFICE FLOOR PLAN -
L. SULLIVAN

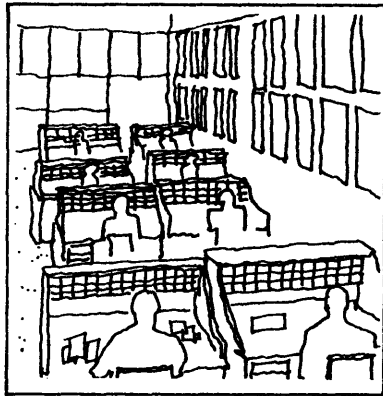

Chicago, the clients were uncertain whether the building should be an office building or a hotel, so they instructed their architects to plan a building that could be used for either purpose. Adler and Sullivan apparently saw nothing odd about this - either use required nothing more than corridors lined with rooms, plus stairs, elevators and toilets. The building ended up being an office building, but an examination of the plan shows that a hotel would not have been very different.¹

The typical desk of 1850 or 1860 reflects the orientation toward solitude and privacy as the office climate. A man facing his desk observed a series of pigeonholes and drawers. For sociological reasons, in effect, a kind of factory. The office worker did not identify himself with the factory hand, and indeed there was, and continues to be, a lag between the mechanization of the factory and that of the office.²

J. William Schulze noted that the space for each unit should be determined by the nature and quantity of its work, with regard to the amount of equipment and personnel involved. Principles of functional efficiency in furniture design replaced the commodious rolltop desk with a flattopped one lacking a carpetbag center drawer. Chairs were designed for the maximum comfort compatible with minimal extraneous movement. But visually desk

rigidly geometric, expressing the standardized, repetitive task performed there. The simulation of the office to the factory model brought, with a huge increase in efficiency, an inevitable decrease in demand for skill and intelligence.

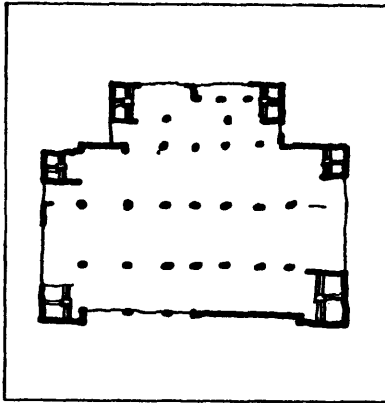

LARKIN COMPANY ADMINISTRATION - F.L. WRIGHT

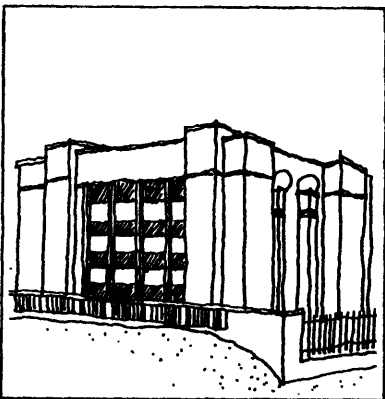

LARKINS BUILDING

The early business office probably served a firm that was a sole proprietorship, that is, had one owner or was a partnership. The offices only needed to seat the owner, or partners, and the staff, which usually consisted of a few clerks.

It was the appearance of the modern corporation and its parallels in modern government that produced the modern concept of offices as a complex grouping reproducing the organizational hierarchy of the firm in its layout of spaces. The quantities involved in mass production and mass distribution create a matching volume of clerical operation and the necessary typewriters and the adding machines.

Frank Lloyd Wright, in his Larkin building and Johnson Wax building treated the office as a total environment. The galleried, lightfilled building and its furniture is the serious attempt to improve quality of office design. Yet, although the openness of his house plans might have yielded

a different system, the arrangement remains linear and workers faced one another directly across their desk.³

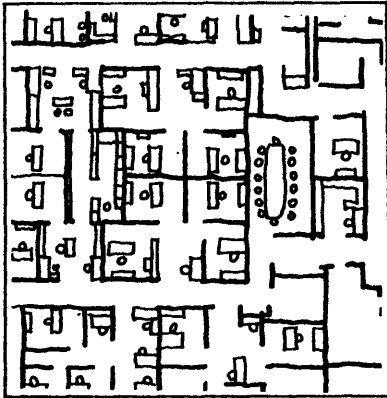

Most of the large skyscraper projects of the 1930's and 1940's made some effort to offer standard building systems that would permit some degree of flexibility. However, it remained clear that owners and architects were still, in most cases, thinking of office buildings as warrens of many more or less identical individual office rooms.⁴ When large companies moved into such buildings they could arrange to have all partitioning left out where open, general office space was desired. Planning was a matter of open spaces plus cubicles. Perhaps there would be a waiting or reception area with more partitions. Often ranking executive offices and board rooms would receive an interior decorator's attention in the form of pseudo-Georgian panelling and furniture. New buildings created a vast acreage of new office space, part of it built as real estate speculation, part of it built for use by business and government. Nearly all of the new buildings were modern in architecture -- the need to plan the facilities that were being built so rapidly created a new field of professional office design.

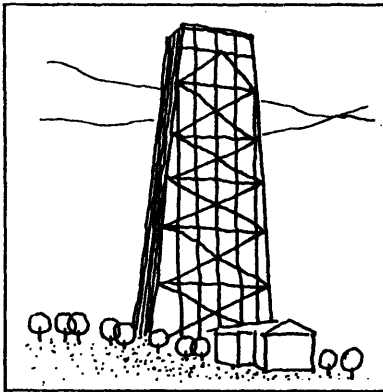

JOHN HANCOCK CENTER -
S.O.M. - DELAWARE

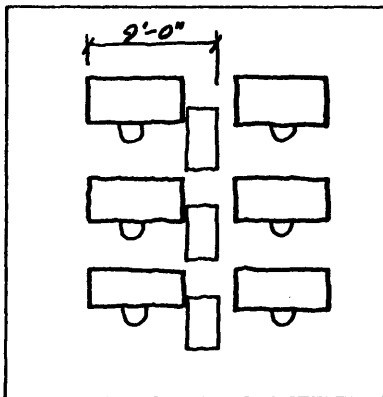

TYPICAL DESK ARRANGEMENT
- TIME SAVER STANDARDS

In theory, the architect is the logical person to organize such projects, but most architects are so exclusively focused on the overall design of buildings that the many small and irritating problems of the offices within do not attract them. Traditional decorators and their newer cousins in interior design are inclined to concentrate on the superficial appearance aspects of the space.

It is a reality of the spacial orientation within office buildings that executives still occupy the partitioned, windowed perimeters, while row upon row of specialized clerks occupy the central office space, working under fluorescent light. Although desk equipment, lighting, and clerical techniques have changed, the arrangement remains the same, and it is fundamentally inhumane.

United States businessmen have grown up with the idea that an office is a place of obvious neatness, of an order as instantly visible as the major axis at Versailles. Total design that turned the office into a Platonic composition of official art, official plants, and official ashtray positions, implies a military academy gone aesthetic.

DEFINITION OF WORK

We measure that which we can measure. This often means that a rich and complex phenomenon is reduced to one dimension, which then becomes prominent and eclipses the other dimensions. This is particularly true of "work," which is often defined as "paid employment."

The definition confirms one readily measurable aspect of work but utterly ignores its profound personal and social aspects and often leads to a distorted view of society. Work contributes to self esteem. An individual is working when he is engaging in activities that produce something valued by other people. That is, the job tells the worker day in and day out that he has something to offer. Not to have a job is not to have something that is valued by one's fellow human beings. Likewise, to be working is to have evidence that one is needed by others. One of these components of self esteem is, therefore, internally derived through absence of challenge in work.

When it is said that work should be meaningful, what is meant is that it should contribute to self esteem, to the sense of fulfillment through the mastering of one's self and one's environment, and to the sense that one is valued by society.

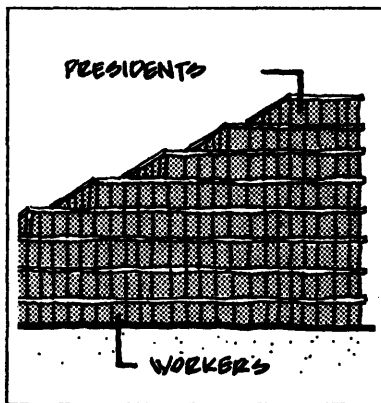

STAIRWAY TO SUCCESS

The people feel that gains in productivity will come about mainly through the introduction of new technology. They feel that tapping the latent productivity of workers is a relatively unimportant part of the whole question of productivity. This attitude was behind the construction of the General Motors auto plant in Lordstown, Ohio, the newest and most efficient auto plant in America. Early in 1972, workers there went out on strike over the pace of the line and the robot-like task that they were asked to perform.⁵ This event highlights the role of the human element in productivity: what does the employer gain by having a "perfect efficient" assembly line if his workers are out on strike because of the oppressive and dehumanizing experience of working on the perfect line. As the costs of absenteeism, wild-cat strikes, turnover and industrial sabotage become an increasingly significant part of the cost of doing business, it is becoming clear that the current concept of industrial efficiency conveniently but mistakenly ignores the social half of the equation.

Such an example is that the open plan office was predominantly organized by the management consultants, the owner of the building, and the interior designer. Their primary focus was work productivity, paper flow, and

1. MANAGEMENT CONSULTANTS
2. OWNER OF BUILDING
3. INTERIOR DESIGNER

DESIGN OF OPEN PLAN OFFICE

organization within the office for the most efficient management. The workers in the offices were rarely asked to participate in the design process in shaping their working environment.⁶

Robert Quinn has shown that both job satisfaction and mental health are poorer when a worker feels "locked-in" to his job.⁷ Workers who feel there is little opportunity for mobility within the organization, or little control over their job assignments, or little probability of getting another job elsewhere, characteristically suffer from tension, job dissatisfaction, and mental problems.

Perhaps the most consistent complaint reported has been the failure of employers to listen to workers who wish to propose better ways of doing their jobs. Workers feel that their bosses demonstrate little respect for their intelligence.

The office today, where work is segmented and authoritarian, is often a factory. There is little to distinguish many jobs other than the color of worker's collar: computer keypunch operations and typing pools have much in common with the automobile assemblyline. Secretaries, clerks and bureaucrats were once grateful for having been spared the

dehumanization of the factory. White-collar jobs were rare. Now such positions offer little prestige. Furthermore, the size of the organizations that employs the bulk of office workers has grown, imparting to the clerical worker the same impersonality that the blue collar worker experiences in the factory. The organization acknowledges the presence of the worker only when he/she makes a mistake or breaks a rule, whether in factory or bureaucracy, whether under public or private control.

Most of the task of introducing reforms and innovations into the work place has fallen to small work groups. Little of this work has embraced the wider implication of the systems viewpoint or involved an entire, large corporation.

TERRITORIALITY AND PRIVACY

It is fair to ask how many office buildings really are functionally efficient while providing pleasant working conditions, how many really integrated examples of commercial architecture exist, and how do many buildings look after only a few years use. The fault is not the architect's alone, for when he/she designs the buildings, the users are frequently unknown, and offices are sometimes badly misused. Moreover, there is quite inadequate feedback to the architect about the performance of his buildings.

The available information on human territoriality is limited and unsystematic; ideas in the area are loose, definition problems exist, and theories have never progressed beyond an elementary and informal stage. Altman, said that human territoriality encompasses temporarily durable preventive and reactive behaviors including perceptions, use and defense of places, people, objects, and ideas by means of verbal, selfmarker, and environmental behaviors in response to the actual or implied presence of others and in response to properties of the environment, and is geared to satisfying certain primary and secondary motivational states of individuals and groups.⁸

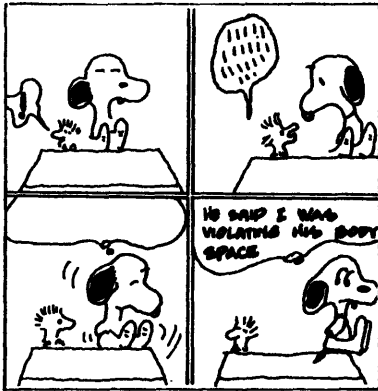

Lyman and Scott also stated that territory provides the individual with identity and allows personal idiosyncrasy and freedom of action. A clear benefit provided by many, but not all, territories is privacy, the right of the individual to decide what information about himself should be communicated to others.⁹ Pastalan stated that privacy may constitute a basic form of human territoriality and pointed out that privacy facilitates personal autonomy, vital to individuality.¹⁰ Privacy is basically an instrument for achieving goals of self-realization. By providing a context for emotional release, self-evaluation and psychological protection, it also allows individual sense of control. Personal space factors are important correlates of social-emotional states. The definition of one's own space is associated with emotional well being.

The studies about the environment and human behavior that deal with conversation, crowding, territoriality, seating arrangement, and cultural messages about space can be loosely grouped under the heading of personal space. There have been many studies about seating arrangements stimulating conversation, affecting leadership recognition, affecting isolation

and alienation, and/or encouraging interaction. These studies of personal space give the designer many interesting isolated observations.

Behavioral scientist E.T. Hall has investigated personal and transactional space and found that for an Arab. the normal distance for conversation is within the area in which one can smell the breath of another person. For an American, this would be much too close for conversation. How people position themselves and maintain distances between themselves and others has been referred to by Hall as their "proxemic relationship."¹¹

Some discussions about personal space deal with the idea of territoriality. It has been observed by psychologist Robert Sommer that people create barriers to define territory. They use their posture or location to convey this idea in a "silent language." If one examines an array of reasons given by individuals seeking and maintaining their privacy, then what is revealed, are attempts to protect and nurture the self, or the positive compliment of trying to extend and enhance the self.¹²

It is apparent that while privacy is often referred to as the individual's choice of aloneness, it is an interaction concept. The individual simply

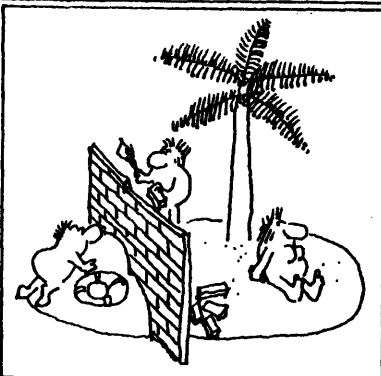
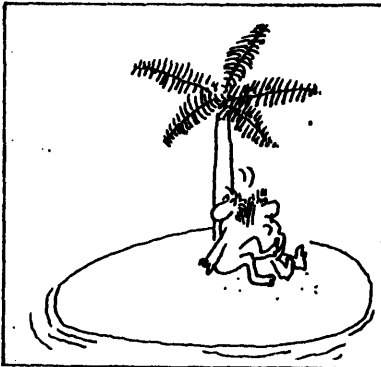
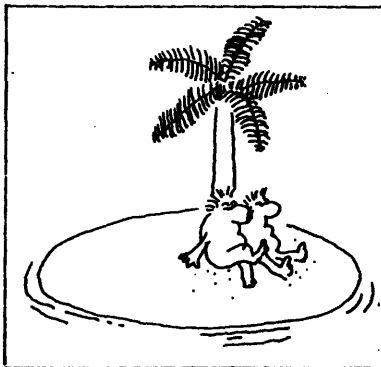

withdraws in order to go off and be alone, to relax, to collect himself, to think things through. In effect, the person seeks to escape from the demands created by the presence of others. In order for the individual to function effectively, over time there must be a reasonable balance between interaction and privacy.

Privacy as interaction takes on still another form. It can be said that in groups and larger social systems, privacy, freedom of privacy, invasion of privacy, and the consequences of invasion are all elements in the rights and privileges that define relationships between people. Thus, the boss can interrupt an assistant at will, but the reverse is unlikely to be true.

Sociocultural forces have a strong influence over the way that office spaces are organized. A window with a view, important to an occupant because it provides momentary relief from work and eyestrain, may also enhance an executives aura of status.

It is interesting to note that many workers introduce personal elements

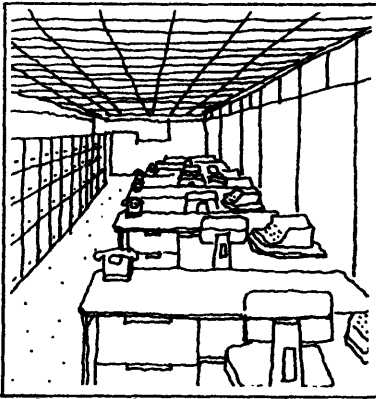

MODERN OFFICE ENVIRONMENT

in their offices. These elements appeared even in open plan offices visited, where the pinning up of pictures and postcards was officially forbidden.

These small symbolic territorial markers may be of utmost importance. Position, distance and zoning are probably of special significance in these situations, and importance is attached to various parts of the space. For example, window positions are of high status value and are generally occupied by senior staff. All the symbols of display associated with a managing director are present. The secretary on the main circulation route provides an effective barrier to intrusion and as a wall substitute.

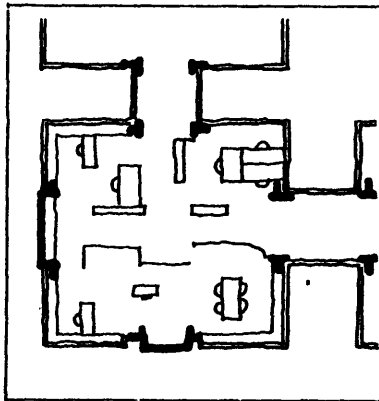

OFFICE UNIT -
HERTZBERGER

Offices in which people can work effectively and with enthusiasm both individually and collectively are important because more people now work in offices than ever before. People like to be able to identify the bounds of this personal environment and to shut themselves away when interpersonal stresses become intolerable.

The design of physical settings may create needs, feelings, conditions for privacy, or may require reduction of privacy because it leads to

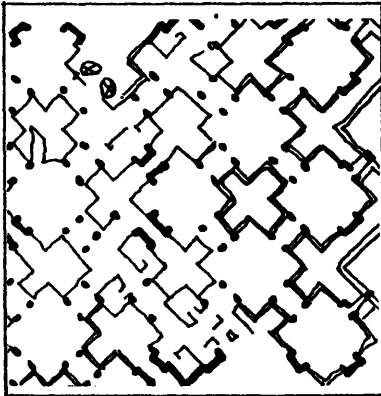

CENTRAL BEHEER - PLAN
HERTZBERGER

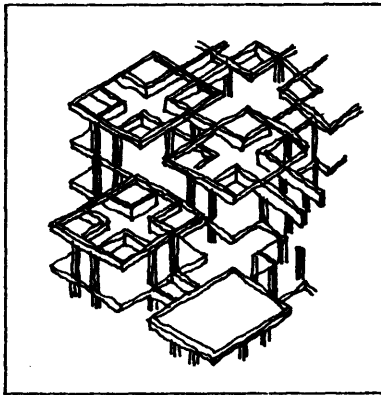

CENTRAL BEHEER -
STRUCTURE, HERTZBERGER

isolation. A noisy block pushes people to create their own private world, but one that is too quiet may lead an isolated individual to attempt to break down its isolating aspects. If we consider cities, suburbs, and rural areas respectively, each facilitates and impedes privacy in ways relevant to the activities, interests and experiences of the people in them.¹³

A general principle is that we should attempt to design responsive environments, which permit easy alternation between a state of separateness and a state of togetherness. If privacy has a shifting dialectic quality, then, ideally, we should offer people environments that can be responsive to their desire for contact or absence of contact with others. Environments that emphasize only very little interaction or a great deal of interaction are too static and will not be responsive to changing needs.

LIGHTING

Lighting is an important element in building design. In a large building, the extent to which the general working illumination will depend upon daylight and how much upon artificial lighting will have decisive effect upon the layout and planning of the building as a whole. The size and position of the windows and type of glazing used will affect solar heat gain in summer and thermal losses in winter, and thus the heating and ventilation requirements. Likewise a multi-story building which is deep in section and relies to a large extent upon artificial lighting will also have to depend upon artificial rather than natural ventilation. It is therefore necessary to consider carefully the ways in which alternative methods of lighting may affect both the capital and running costs of a building.

DAYLIGHTING

Windows have always been of major importance in determining the form and character of buildings. It is a long journey from the unglazed "wind-eye" in a medieval castle to the curtain walls of today - tinted, louvered, draped and sealed. At each period window design has been determined by social, economic and technical considerations in addition strictly to

lighting requirements. From time to time the needs of security, limitations of the structure, and the size of available glass panes have all played their part.

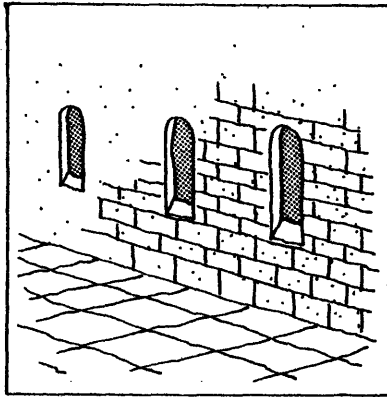

MEDIEVAL CASTLE WINDOW

The high windows in the baronial halls of the later middle ages were based upon the defensive forms of the moated castle. Later, in more peaceful times, the largest possible window was the aim, springing either from religious aspirations or from social status-seeking. This was curbed, in cities such as London, by the need for precautions against fire. At times influences from abroad have been felt, such as the eighteenth century when some of the Palladian buildings were based on models with the limited fenestration suited to the much hotter Italian climate. In the Baroque period, lighting developed a theatrical character with concealed sources and carefully composed views, and with a unification of painting itself. Probably the most interesting period of direct relevance to our present technology is the late seventeenth and eighteenth centuries, when a steady refinement of detail led to improved quality in daylighting. The splayed window reveals, which originated in the medieval firing embrasures and the moulded perpendicular

mullions adopted in the characteristic Georgian and Regency window with its refined window bars, have now been shown to have valuable properties of guarding the contrast of light from the sky to the interior of the room. These have become part of modern technology.

Window technology has developed until now toward larger and larger glazed areas. However, the displays of technical virtuosity in design of very large windows which were characteristic of the first half of this century are now being tempered by realization of the environmental problems created by such large areas of glazing. The first of these environmental problems to be recognized was the loss of internal heat through a single skin of glass. More recently, increasing traffic noise has aggravated the problem. As a result, the designer has had to cope simultaneously with complaints of excessive noise, sky glare, excessive solar heat penetration, loss of internal heat, and inadequate ventilation.

The many suggested solutions must depend upon all aspects of the environment and not only on the lighting. The complexity of the window problem in the modern world should not lead to disregard of the benefits of a visual link with the outside world.

Before artificial light was cheap, work necessarily had to be done close to the artificial light source because there was insufficient illumination anywhere else in the surroundings. Later, general lighting became economically possible. General lighting of the whole building presently is the usual practice through both artificial and natural lighting. Nevertheless, many people feel an instinctive preference for some selective light on their own work. In buildings with good natural daylight, people prefer to work near or under a window. In artificial lighting, they like to supplement the general lighting by an individual light of their own which they can adjust to their personal needs.¹⁴ This desire for a personal light is by no means universal. It depends upon the kind of task which is being undertaken, but generally it is true for those visual task which demand concentrated attention on matters of fine visual detail.

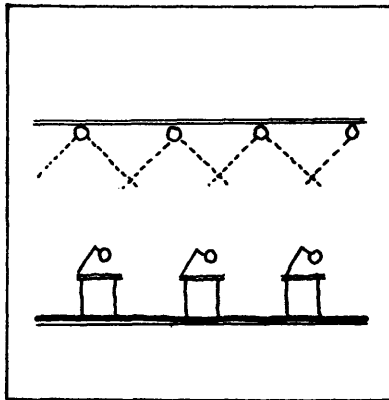

GENERAL AND LOCAL LIGHT-
ING

This preference for individual light is in line with what we know about human vision. Experimental work has demonstrated that the best vision results when the work is slightly brighter than its surroundings, and that the greatest visual comfort results when there is a gradation of brightness from the visual task itself, as the brightest area in the

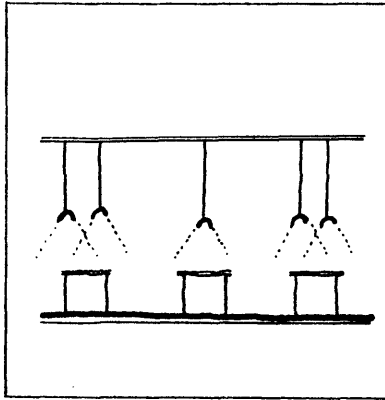

LOCALIZED LIGHTING

visual field, through intermediate zones, to a moderate level of brightness in the general surroundings.¹⁵

Finally, it has also been shown that attention is held most easily and distraction is avoided, if the work is illuminated to a preferentially high brightness so that the eyes are drawn to it naturally and without strain.¹⁶ Experience and experiment, therefore, both lead to the decision that the best form of lighting ensures good general lighting in the building and also some preferential lighting to aid in directing attention to the work and to improve visual acuity. This preferential lighting does not necessarily entail the use of individual light fittings. It can be achieved by a suitable distribution of light from sources integrated in the fabric of the building. In cases other than working areas, special lighting may emphasize lighting to direct the attention, such as to the display areas of an art gallery, to the chalkboard of a school classroom, to the goods on sale in the supermarket, or to the special religious features such as the altar in a church.¹⁷

The building lighting and the special lighting may come from the same system, or they may come from different systems. During daylight hours

it is usually much more convenient to provide the building lighting by natural means, while providing the emphasis lighting by artificial means. At night there will be a combination lighting system, part providing the general building lighting while a special supplement, probably with directional characteristics, provides the emphasis lighting.

DISCOMFORT AND GLARE

The eye cannot tolerate excessive light. While inadequate light leads to eye strain, discomfort and distress, too much light leads to glare and dazzle, and consequently discomfort of a different kind. The designer therefore has to steer a middle course between lighting which is inadequate for its purpose, and lighting which taxes the eye beyond its comfort limits. Under daylighting conditions, glare results from a very bright sky seen through a large window. Under artificial lighting conditions, glare arises through direct view of excessively bright light sources inadequately screened.

Glare is also a function of contrast. If a bright light is seen in

dark surroundings, it will cause more glare than if seen in light surroundings. The juxtaposition of a bright area of sky and a dark wall can be intensely dazzling, even though out of doors the same sky can be looked at with impunity. There are consequently two aspects of glare which have to be watched in interior lighting design -- glare which arises because of harsh contrasts between juxtaposed areas, and glare which arises because areas are of such an excessive brightness. that the visual mechanisms is saturated.¹⁸

The main problem of glare in buildings is discomfort. Rarely does glare in a building cause direct disability, although such situations do occur. For example, a window at the far end of an otherwise unlit corridor is a typical example of a design situation in which glare impairs vision. A high clerestory window to the unobstructed sky also can cause disability in the area around the clerestory. However, normally it is discomfort which is the biggest disadvantage of clerestory lighting rather than disability.

Discomfort due to glare also affects the general efficiency of the work over a long period, buildup annoyance, frustration and irritation.

It has been shown, however, that the effect on human efficiency is very difficult to measure. In much the same way the effect of noise in a building is more important because of the distress which it causes than because of the actual reduction in work efficiency.

Deprivation of daylight is believed sometimes to cause health disorders, either "somatic," that is, the upset of the regular kinds leading to illness and ill health. The evidence for this comes, as we might expect, from Sweden, Finland and Russia, where there is a serious lack of daylight in the winter months. The evidence is not conclusive, because it could well be argued that these illnesses arise from factors other than lack of daylight, such as the separation of workers in the northern mines and forests of Sweden from their families in the South. Nevertheless, these same illnesses do not happen in the same way in other climatic environments where there is sufficient daylight.¹⁹

Studies have been conducted on the preferences of office workers and home dwellers for daylight and sunlight. As one might expect, the desire for sunlight is strongest where its duration is most limited. Furthermore, this desire may be proportional in some way to the degree

of physical confinement in which a particular activity takes place.²⁰

Louie Kahn expressed his awareness of this when he stated "the cloud that passes over gives the room a feeling of association with the person that is in it, knowing that there is life outside of the room..."²¹

The need for a view of the outdoors, and how this view is affected by different types of solar glasses, has also been investigated. It is found, for example, that office workers whose offices had window walls, 60 percent of the area of which was glazed with solar reflector glass (15 percent transmitting), complained of the depressing visual effect of the external view. They cited reduction in luminance, the need to use artificial light during the daylight hours, and the fact that the glass became a mirror to the room interior when external illumination levels were low.²²

With the availability, in the 1950's of full air conditioning, offices and even schools could be built without windows to disturb their controlled climates. Besides the control imposed on the ventilation and temperature of the interior climates, the lighting was maintained at a suitable level through the use of extensive artificial illumination.

In spite of their energy and economic advantage issues of the health of the building's occupants seems to have been given lower priority than the expedient, technological, controlled solution. With such widespread application of cheap, controllable lighting came a reduced sensitivity towards natural light. Rooms that lack windows and thus natural light, are usually seen by their occupants as depressing, psychologically numbing, and tension producing.²³ There is no contact with or knowledge of the weather or the time of day, and no visual relief. Such a lack of light may ultimately have an effect upon human performance.

Even so, no designer free of commercial and economic constraints would feel confident in designing a building from which all daylight is excluded merely on the grounds of economy or convenience in design.

Probably the real advantages of daylight, however, are to be sought not so much in the spectral composition of the light, but more in the fact that daylight is provided by windows. Windows have the dual functions of admitting light, but also enabling us to see outside and to maintain visual contact with the outside world during the work day. One can see that the clouds move, that the moon is visible in the

blue sky during the day, that the rain comes from heavy billowing groups of clouds, and that, in fact, the external world is continually changing in an interesting and fascinating way. There seems to be a real human need for variety and change, and windows offer opportunity for physical and psychological relaxation.

There is no doubt that people judge the adequacy of the daylighting in a building first and foremost by whether they can see to do their work well and without visual strain. If they have more than sufficient daylighting to see well, they then judge the daylighting by the shadows and by the presence of dark areas and by the limitations which these dark areas place on their ability to locate their work around the room.

But above all, their judgements are governed by the amount of bright sky which they can see. This bright sky can have a dual effect. If it is directly in their field of view, and they cannot turn away from it, it can raise the adaptation level to the extent that areas in the depth of the room, though receiving plenty of light, nevertheless look dark. If the bright sky is not directly and continuously in the field of view, the effect can be pleasing.

In order to provide daylighting which is appropriate to the function of the building, the designers must have a thorough knowledge and sympathetic understanding of how the building is going to be used.

NOISE

One of the most controversial aspects of office planning is the sound and noise pattern. Sound at the wrong time and place is noise. In the office, noise is what interferes with concentration or exposes someone to sense of an invasion.

Room in which noise can be expected should be isolated both horizontally and vertically from sections of a building that can least tolerate noise, or should be located on those parts of the site which will probably be exposed to other (interior or exterior) noises. Conversely, rooms requiring quiet should be located on the quiet part of the site or side of the building.

Rooms not particularly susceptible to noise can be located so that they act as screens or baffles between noisy and quiet areas. Adherence to the principle of separating noisy rooms from quiet ones at the planning state will reduce to a minimum the need for sound insulating building materials or systems, thus reducing building costs.

Offices should facilitate the way people work together. People who work in a group regardless of rank, and departmental status, should have an easy access to each other. The privacy one feels does not apply to

acoustics. The noise level in a corridor is usually quite low and the conversation of a person in an office is easily heard. The office door might open to a typing or machine area. Not only does the occupant of a private office have to listen to sounds of the outer office intruding on the environment, but since the outside din is not continuous, there will be lapses when sounds from the private office are audible to everyone outside it. Wall construction may be inadequate acoustically. An induction unit or duct work can furnish a path of communication.²⁴

It is rare that speech privacy is required in offices of any type, whether partitioned or open. The obvious exceptions are conference rooms and offices used for discussing very confidential information. The main concern is to insure that the conversations and sounds will not interfere with another person's concentration.

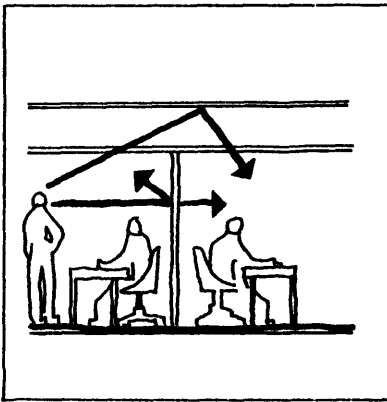

In the office, sounds travel spherically, in all directions, if the sound does not encounter reflecting surfaces like walls, ceiling and floors. Sound intensity decreases as it leaves the source. Therefore, the further you are from the source, the less you hear.²⁵

Distance is one way to insure confidentiality. Conversation should be

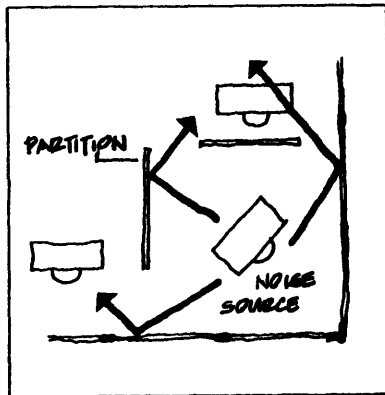
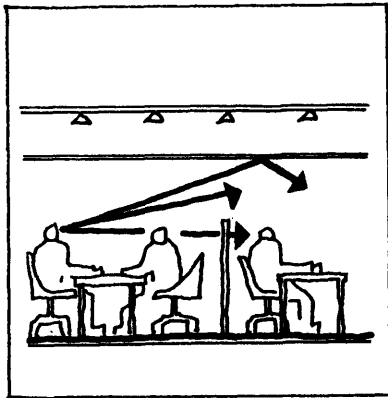

REFLECTORS OF SPEECH
SOUND

confidential if an unintended listener is sixteen feet away.²⁶ Maximum acoustical energy occurs directly in front of the speaker. Direct face-to-face or line of sight contact facilitates communication. If greater privacy is desired, the speaker should not face the unintended listener but be to his or her side or back. This concept explains why early German office landscape layouts had a random pattern of desk placement. However, acoustical problems arise for two reasons. One is that the unintended listener is frequently closer by, and the second reason is that reflective surfaces propagate sound reflective surfaces, whether they are the walls, ceiling, floor, or acoustic panels, create reverberant energy. Its distribution and buildup can be controlled by absorptive materials. Sound absorbing materials not only absorb the sound of the speaker, they also absorb all background masking sounds.²⁷ Sounds bounce off all surfaces within an enclosure in the same manner as a shout will bounce off a mountain and come back as an echo. An echo is a delayed return, delayed because of the distances involved and the time it takes the sound to travel. This is "reverberation time." The sound continues to bounce, losing energy with each reflection. In an

office, the distances are less than outdoors. Sounds are reflected from closer surfaces and the reflected sounds do not appear as an echo, but as a reinforcement. The reinforcement creates a gain of sound pressure at a distance from the person speaking, or the machine source. This sometimes can focus the sound at distance greater than sixteen feet away from the speaker, making her or him audible and intelligible, regardless of the space between the speaker and the listener. The buildup of sound comes from the reflecting surfaces in the space, the ceiling, the floor, the windows, and the walls. The greater amount of reflected speech attributed to the ceiling.

The ceiling is an effective area for sound reflection or absorption. It contributes more to the control of sound than vertical surfaces in workstations and acoustic panels. Acoustic treatments on other surfaces supplements the sound absorption properties of the ceiling

CEILING:

The primary purpose of an acoustical ceiling is to reduce reflected sound energy. There have been many ceiling systems that are successful

is office environments. A ceiling can consist of acoustical absorption material, lighting fixtures, and air terminal devices.

The sound absorption of ceiling materials and all other materials is measured by the manufacturer who publishes their performance data.²⁸ However, in considering the NRC of the ceiling material, it should be thought of as part of the total ceiling system, including the luminaries, the air distribution system, and so on.

The ceiling baffles can improve the reduction of sound energy within the office. Such absorptive panels can be hung beneath the acoustical ceiling system. Ceiling baffles in certain situations can be installed in specific sections of the ceiling to control the sound generated there. Ceiling baffles can make up for deficiencies in acoustical tiles.

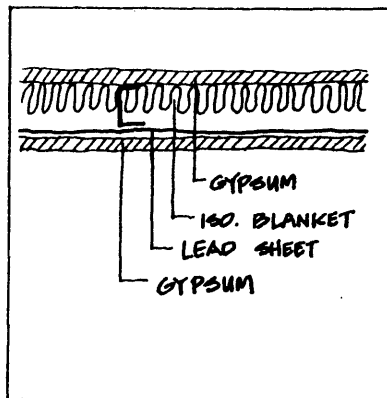

SHEET LEAD IMPROVES THE SOUND INSULATION

VERTICAL SURFACES:

Vertical surfaces, such as walls, drapes, windows, movable acoustical panels or screens, and work stations, are important because of their potential sound reflecting characteristics.

As an acoustical control, screens seem to have a limited value, since

the speaker can be constantly moving and sound is not focused at the screen. The sounds a speaker makes can go over, under, and past the sides of these panels. It has been observed that panels are used by people in the office, not to control sound, but to define territory.²⁹

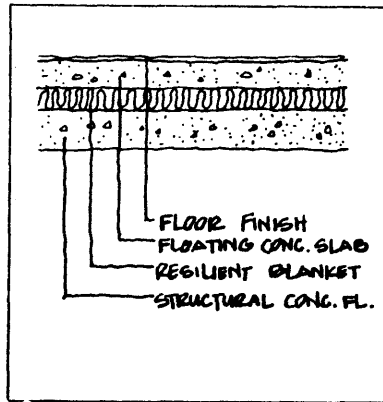

FLOATING FLOOR

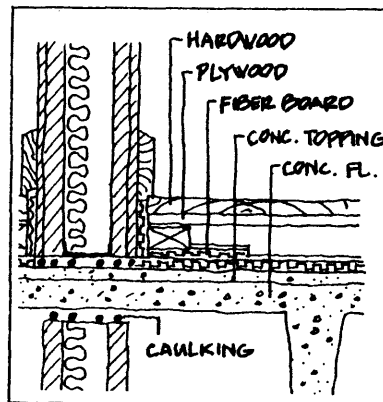

RESILIENT FLOOR

FLOORS:

An acoustically efficient floor construction should provide adequate protection against both airborne and impact noises. A floor with thick carpeting which adequately reduces impact noises is not necessarily satisfactory against airborne noises. On the other hand, a thick, bare concrete slab which gives satisfactory insulation against airborne noises will not provide adequate protection against impact noises originating from the room above.³⁰

The sound insulation of floors can be improved by, resilient surface, a floating floor, suspended ceiling.³¹

DOORS AND MOVABLE PARTITIONS:

Doors constitute acoustically weak elements of walls because 1. their

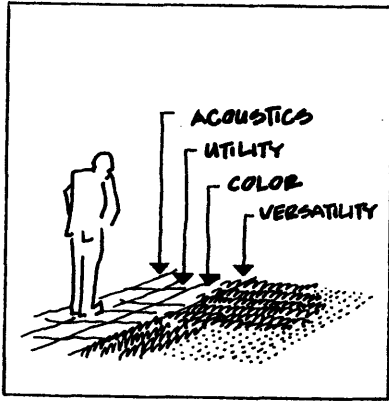

FLOOR MATERIAL CONSIDERATION

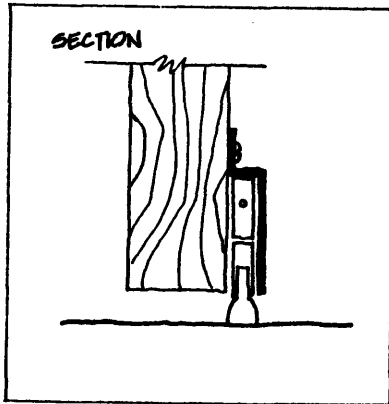

SOUND INSULATING DOOR

surface weight is normally less than that of wall into which they are built, 2. the gaps around their edges, unless sealed, offer a passage for the transmission of noise, and 3. they are considerably smaller than an average partition, consequently their low-frequency resonances occur at a more critical range of the audio-frequency spectrum.

Sound-insulating doors should be of solid-core and heavy (rather than hollow-core and light) construction, with all edges well sealed. Lightweight, hollow-core wooden doors are dimensionally unstable and can warp, destroying the seal along the perimeter of the door. Rubber, foam-rubber, or foamed plastic strips, adjustable or self-aligning stops, and gaskets can be used for sealing the edges of doors. They should be installed so that they are slightly compressed between door and stop when the door is in a closed position. In simple cases the bottom edges can have a replaceable strip of flat or foam rubber attached to minimize the gap between door and floor. A more effective alternative is to install drop bar draft excluders, called automatic threshold closers.

Offices where rooms are located along both sides of corridors, doors

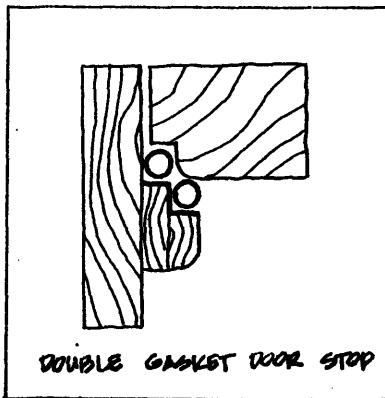

should be staggered so that noise from one room will not penetrate directly across into another. Staggered doors give sound a longer distance to travel so that sound waves are absorbed in the corridor to a certain extent before reaching adjacent rooms.

When a particularly high degree of acoustical privacy is required for a highly effective and expensive sound-insulating door may be avoided using two moderately sound-insulating doors or a sound lock. All wall, floor, and ceiling surfaces within a sound lock should be rendered sound-absorptive, in order to achieve maximum attenuation of noise transmission through the sound lock.

WINDOW:

Like doors, windows constitute weak components in exterior walls and enclosures because their surface weight is much below that of the exterior wall and their connection with the wall, unless adequately sealed, constitutes a direct path for the penetration of exterior noise. However, windows do provide some acoustical advantage by allowing exterior masking noises to enter the buildings, thereby covering up some of the noises that may come through adjoining walls or floors.

PROGRAM

Massachusetts Insurance company deals mainly in life, medical and accident insurance policies. The company has become a liason between the government and their clients in setting various matters, such as medicare and pensions. The work load principally consists of paper processing and researching the policies which sales people have written previously, as well as, constant contact with clients in filing new claims and closings. The M.I.C. predominantly deals with clients surrounding the Wellesley vicinity. Its sales personnel are in constant physical contact with clients. M.I.C. is a revenue sharing firm with workers' voice in the decision making process. The atmosphere sought is that of a relaxed work environment. The setting should also be somewhat responsive to the users. The activities involve both working alone and in concert at various times. Another major determinant is the need for a setting which respond to constantly changing spatial requirements as groups form or dissolve.

M.I.C. is concerned with the humanizing role of the physical setting as well as the ongoing development of a corporate identity. The administration of this organization insists that the office not be a sterile environment, but that the work and the workplace act as positive elements in

the life of the workers.

Emotional and physical sensations are stimulated by the design environment. The transition from one point to another is facilitated when surroundings are identifiable to the user. Thus, an optimum directionality should be easy to understand without conscious attention.

Entryways should be recognizable and should provide information about the following sequences. Changes in the direction and levels should familiarize the user so as to assist in his means of approaching the building. Transitions can be varied by changes in the dimension, the texture of the vertical and horizontal layers and by a variation of materials employed.

Along the spine of the pathway, different levels of the activity should stimulate the surrounding environment, but also provide privacy. Pathways should be flexible accomodating the work environment and social interactions, rather than closed in or totally open.

The work environment should provide a flexible space allowing workers to modulate their work environments. Traditional cubical office space obstruct interaction between the staff and have a tendency to isolate individuals.

Open plan offices reduce one's identity in the larger realm. Distractions within the open plan office hinder the work process. Thus, the optimal work environment would be neither of the two extremes. Rather, the setting should provide various dimensions to stimulate interest and membership.

ASSOCIATION AND ARTICULATION IN THE DESIGN PROCESS:

1. Vertical opening and access
2. Natural light consideration
3. Solid, transparent (glass blocks) and partial walls
4. Columns and bearing wall (structure and life surrounding the structure).
5. Quality of hierarchy
6. Public and private spaces
 1. Along the spine
 2. Private work area
 3. Public work area
 4. Eating area
 5. Collective area

PROGRAM BREAKDOWN:

1. Staff
2. Office type functions (clerical, supervising and technical functions).
 1. Acturial
 2. Benefit administration:
The service of health care, hospital claims
 3. Data processing service
 1. Computer service - Information storage
 4. Financial and General service
 1. Accounting
Processing financial matters - work independently from other department
3. Special workplace
 1. General equipment or file areas
 1. Copying machine
 2. Mail handling equipment
4. Supporting service
 1. Kitchen
 2. Place to eat
 3. Employees lounge
 4. Receiving dock
 5. Lobby facility (Information)
 6. Toilet
 7. Conference rooms
 8. Library

SITE

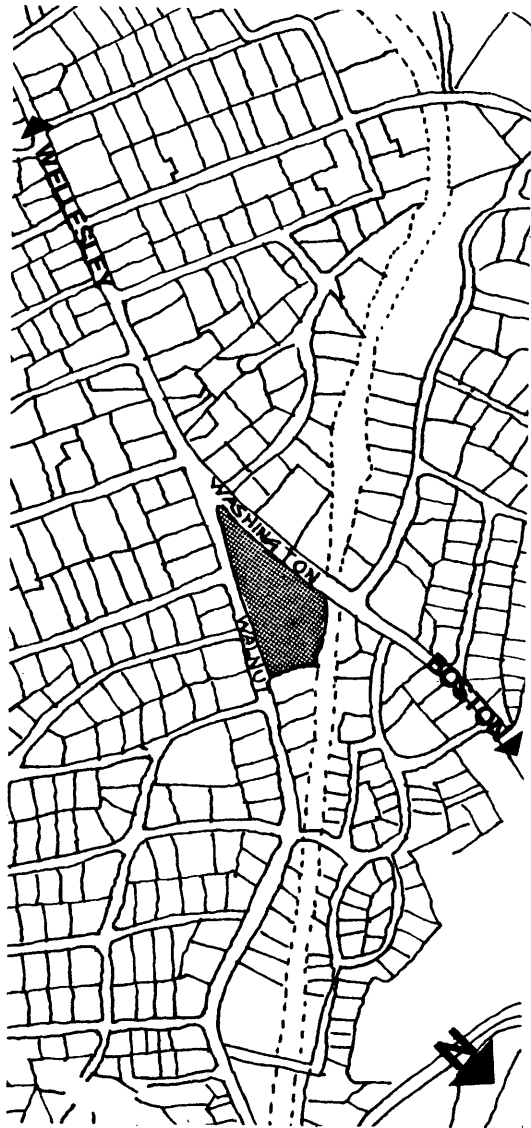

The Wellesley area incorporates the neighborhoods of Newton, Weston, Needham and Natic, Massachusetts, lying in an inverted triangle of land created by the surrounding cities. Major through streets run north-southwest on which commercial, institutional and residential uses are located.

North-southwest streets connect Weston, Cambridge and Natick and these two edges have determined most of the commercial development. The building's site is bounded by Walnut Street to the southwest and Washington to the north.

Most of the buildings along Washington Street, connecting Wellesley and Newton, were developed during the early 1900's. The large commercial developments in this part of the area are clustered on the neighboring line between Newton and Wellesley and are three blocks south of the site. Washington Street is one of major routes between Wellesley, Cambridge and Boston. Secondary commercial areas of small neighborhood stores are developed along Walnut Street which follows the curve of the aqueduct.

For the most part, Wellesley's buildings along Washington and Walnut

Streets are nineteenth century in design. They are primarily two or three stories high except for the east edge, which is residential.

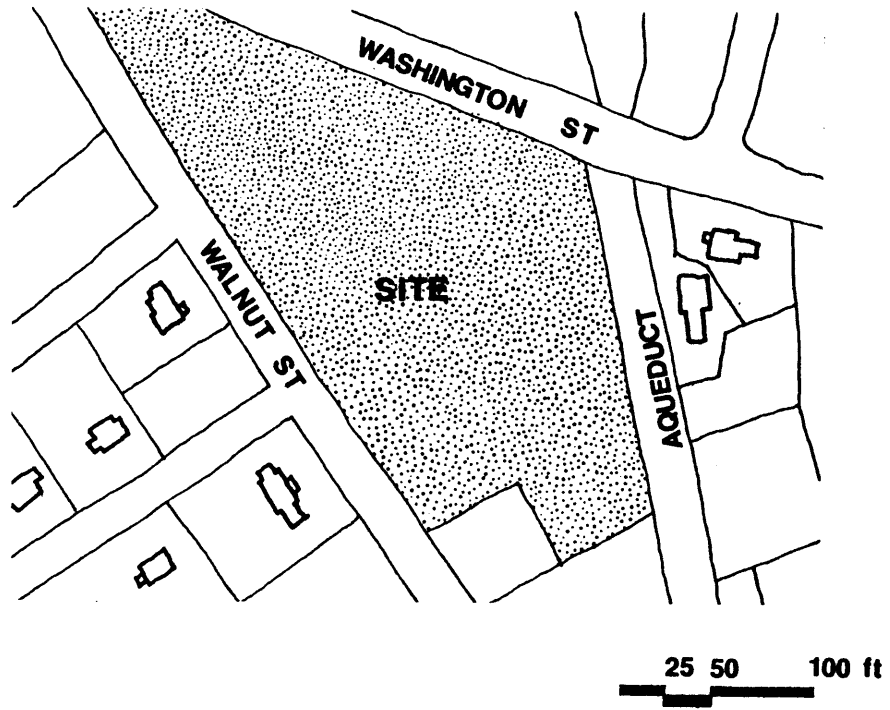

IMAGES

FLOOR PLAN ARRANGEMENT

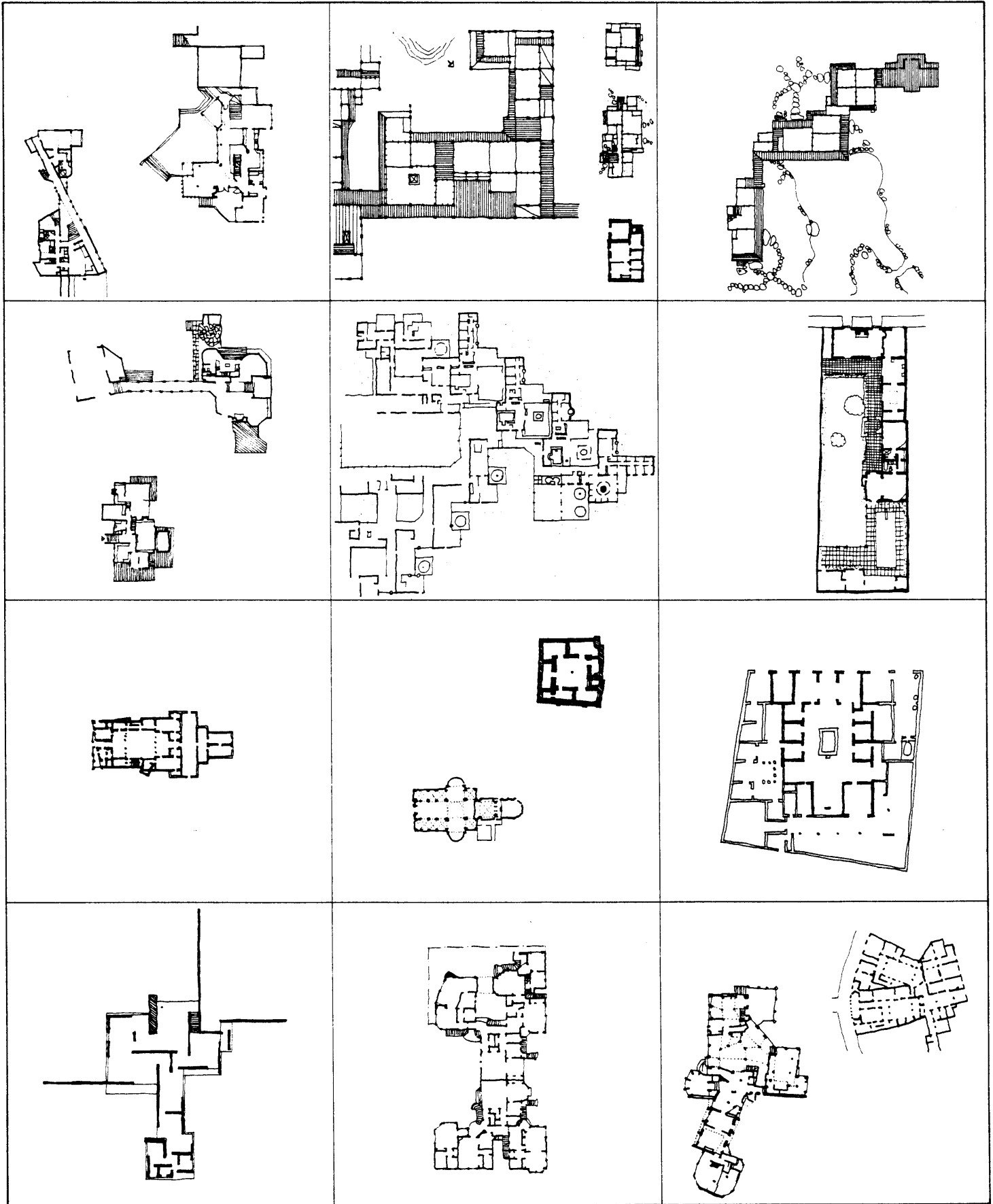

FLOOR PLAN, CEILING, AND WINDOW ARRANGEMENT

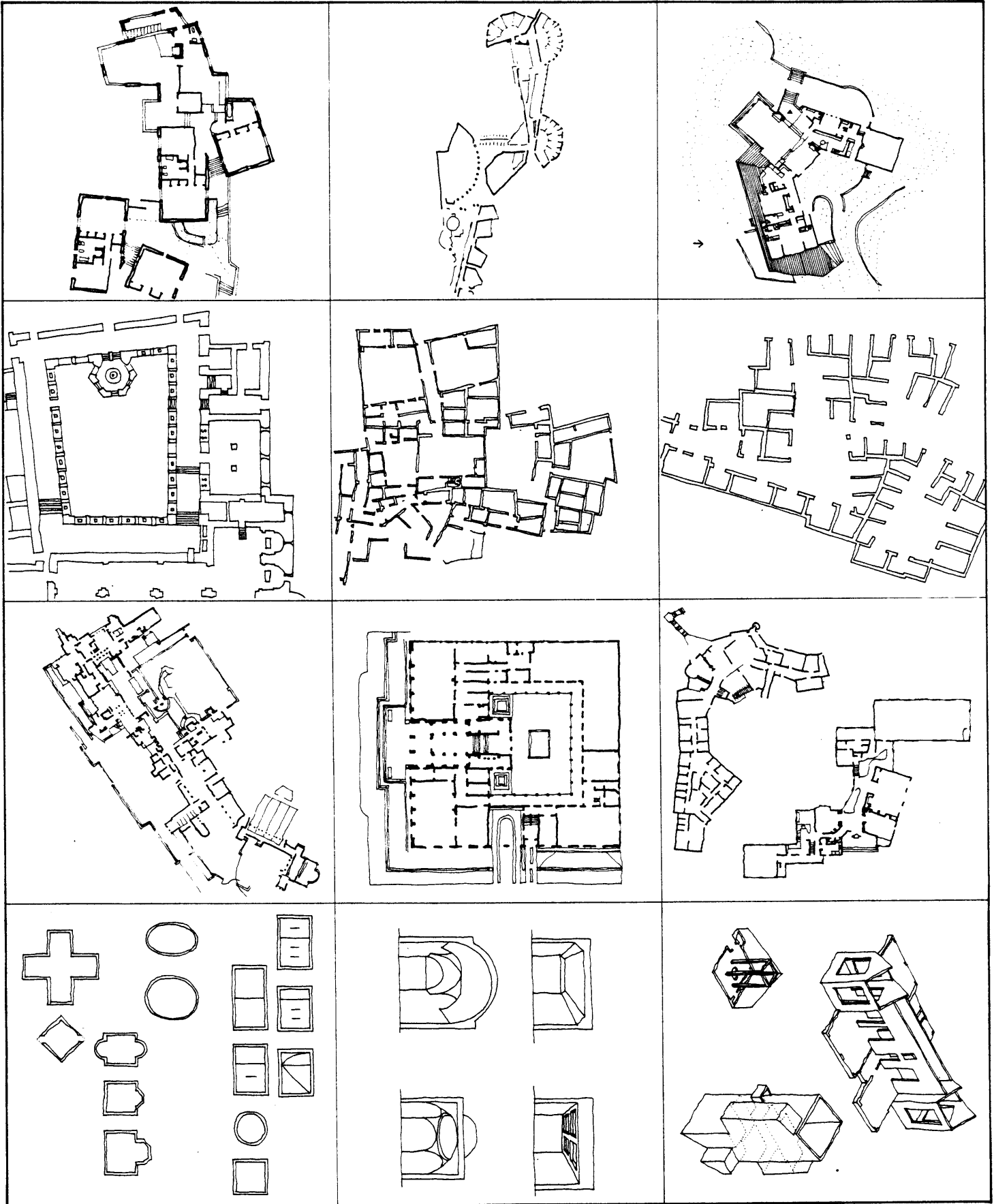

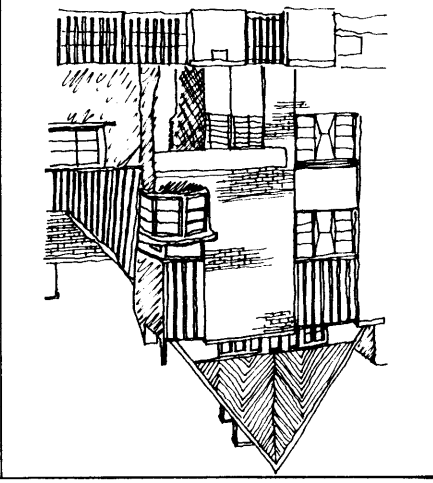
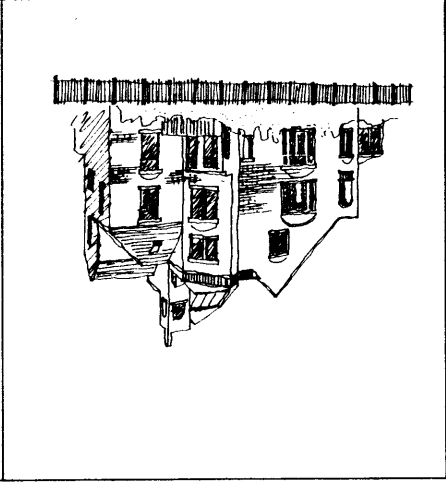
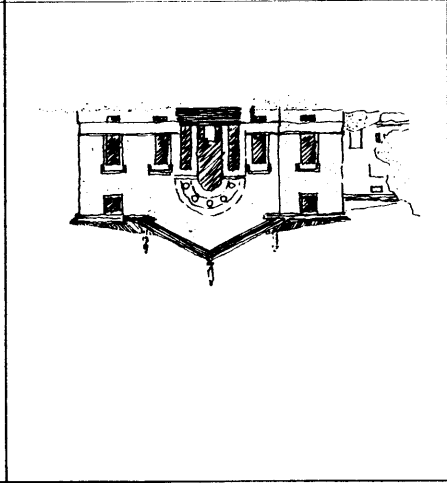
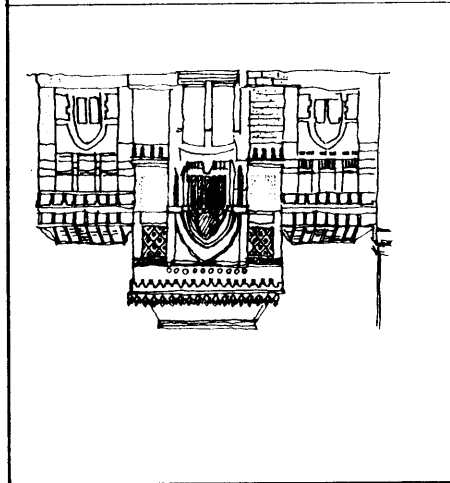
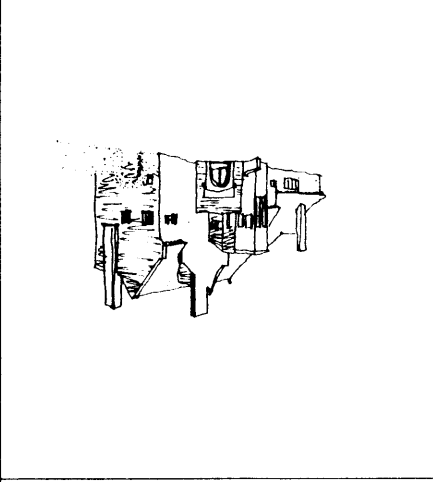
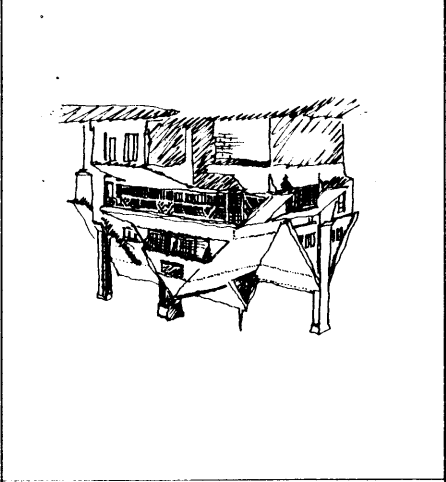
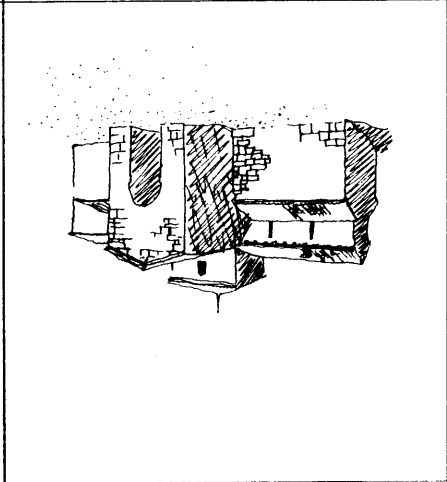
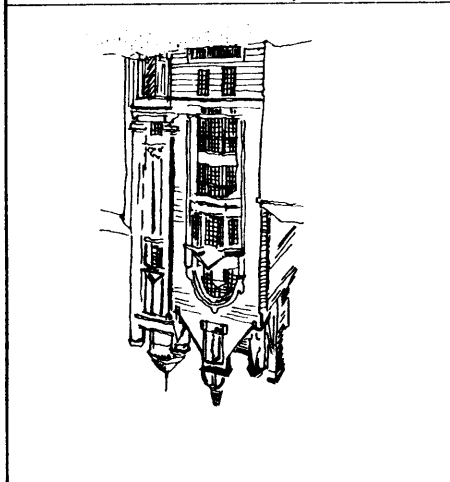
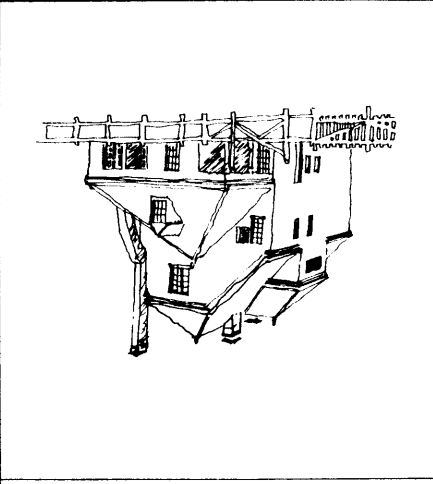
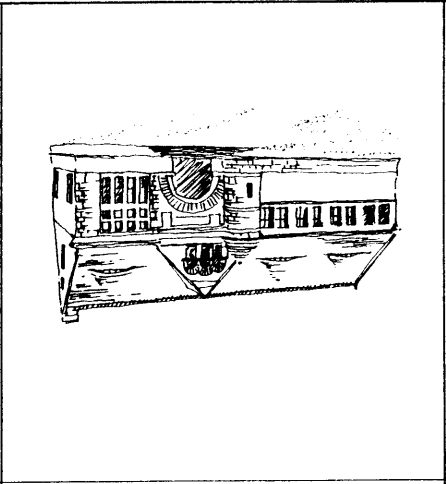
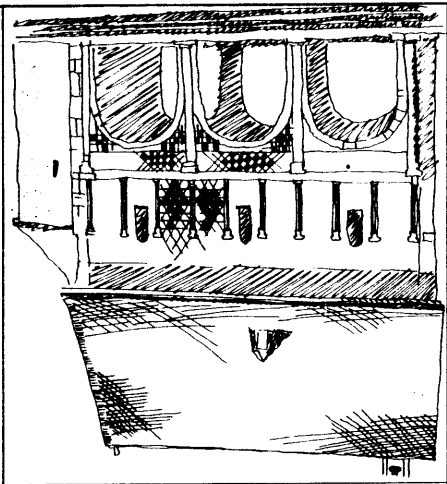
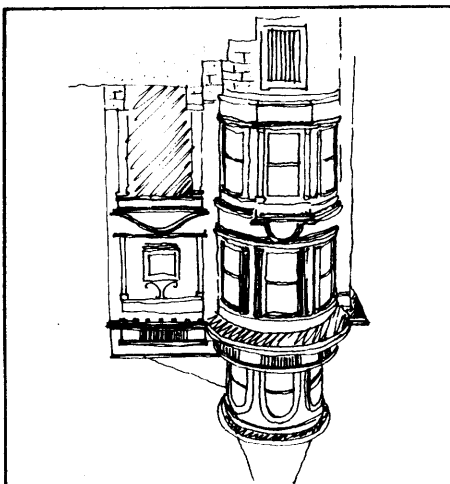

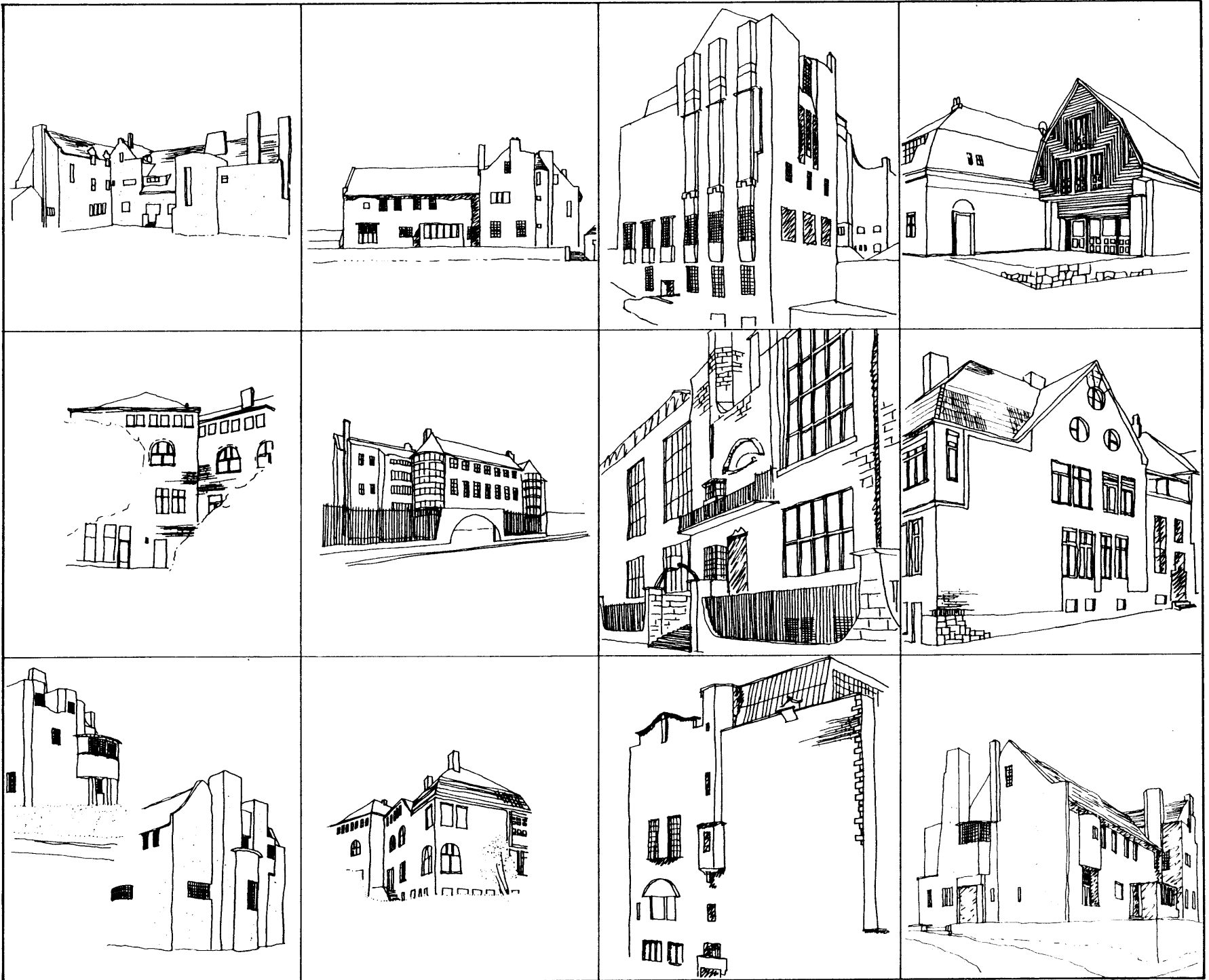

MASSING

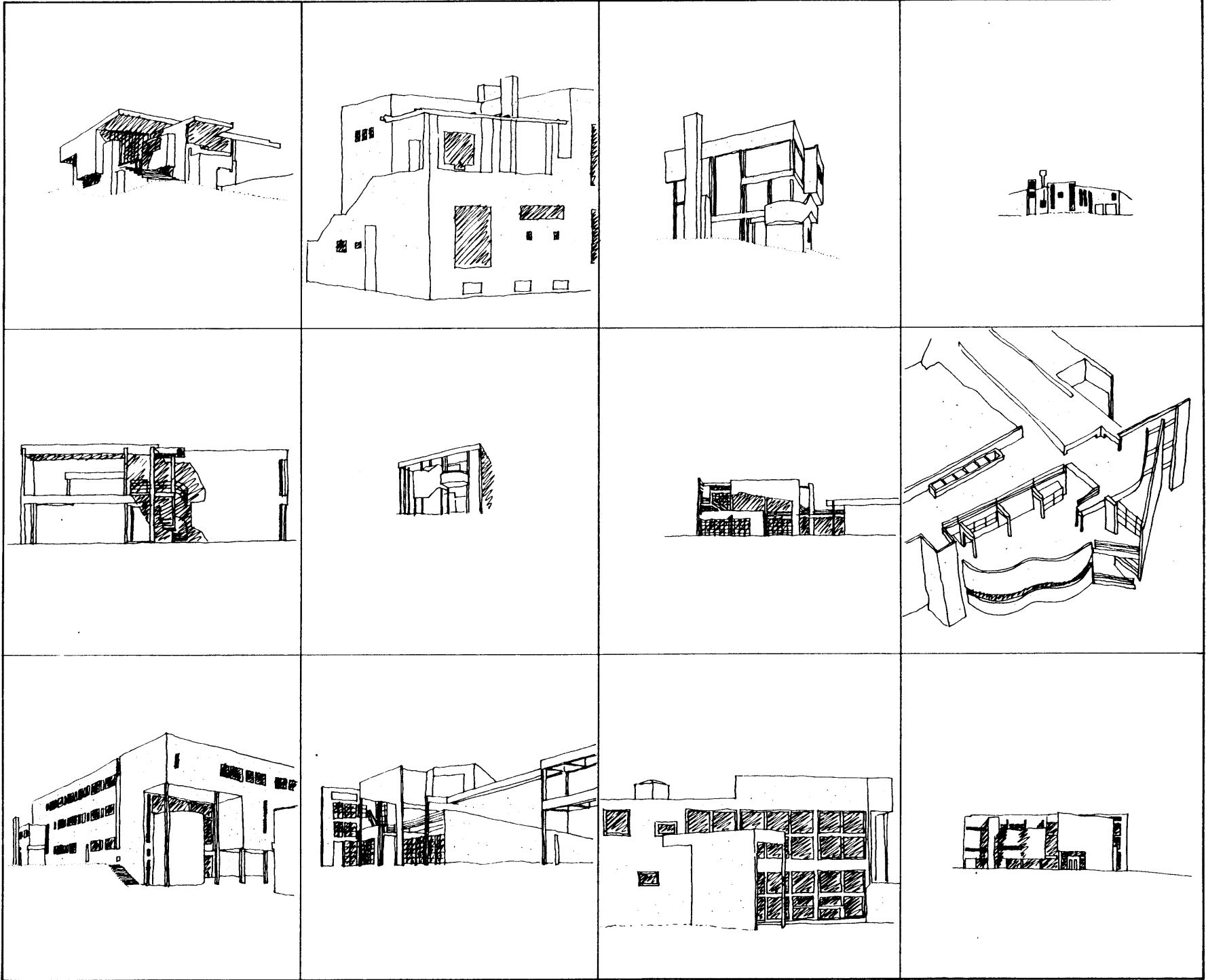

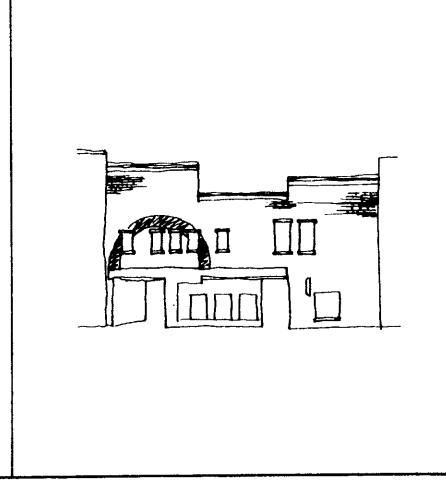
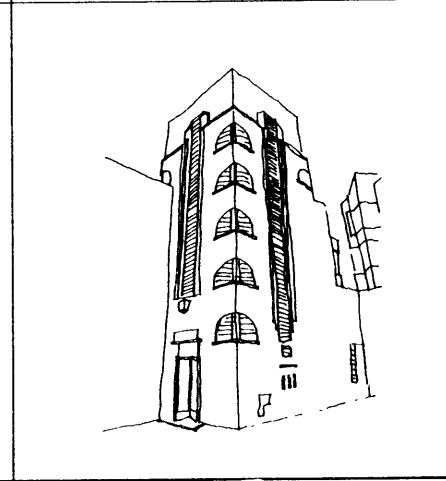
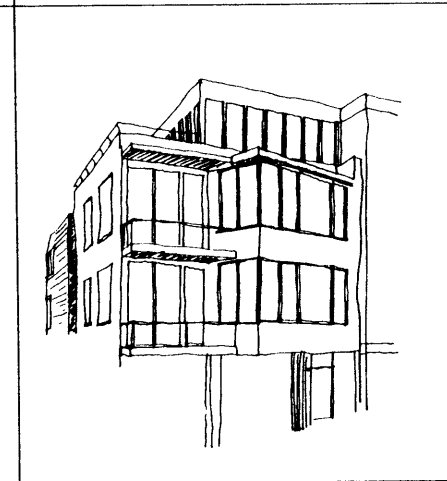
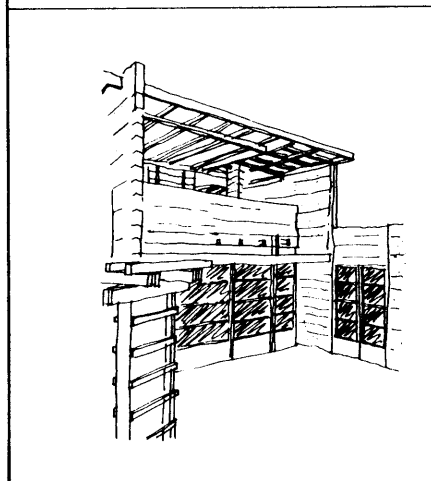
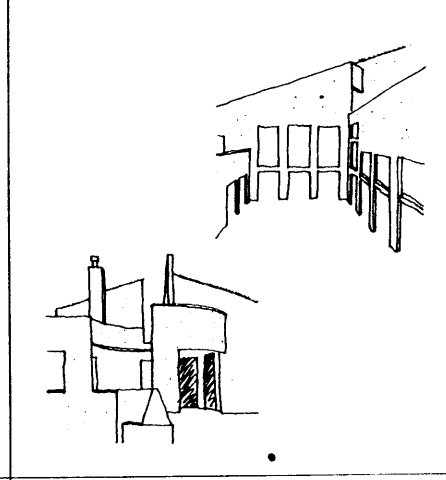
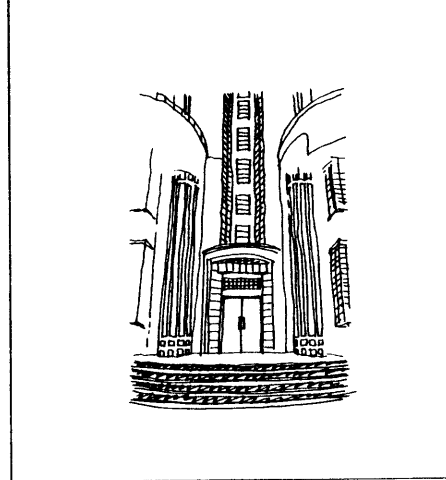
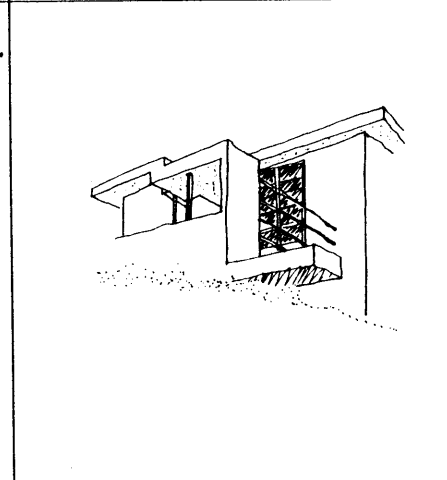
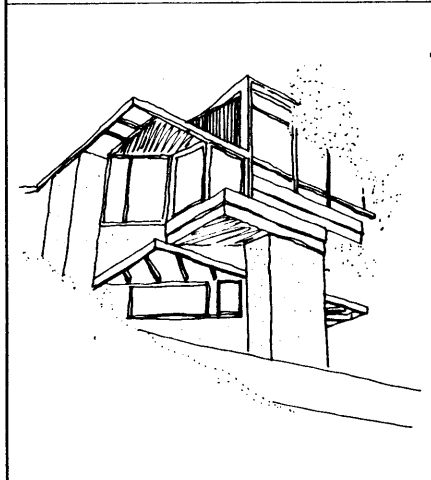
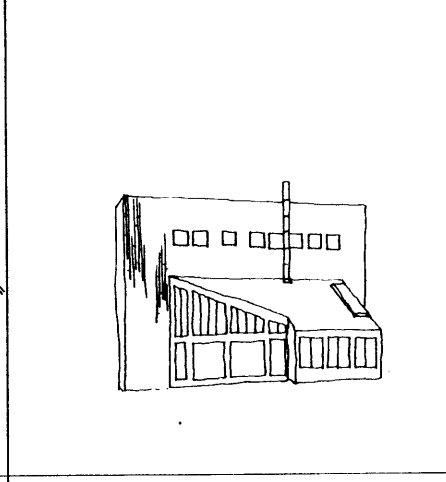
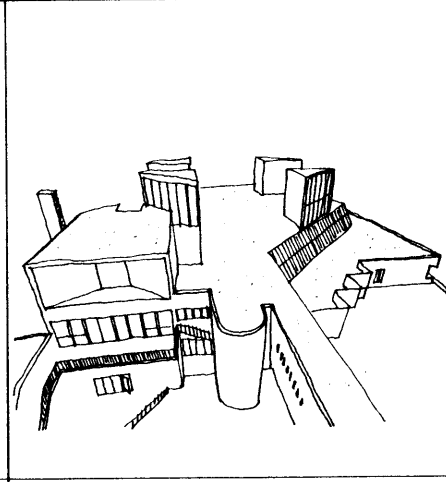
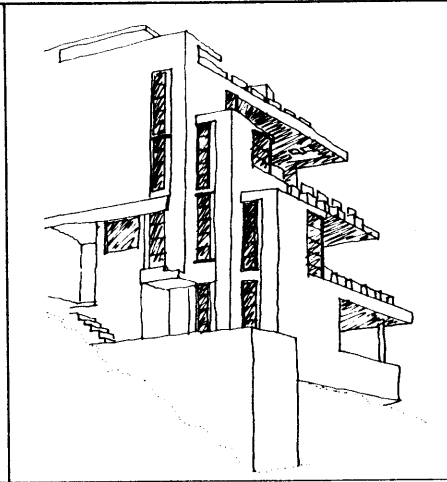

PATHWAY, INFORMATION, AND PAVEMENT

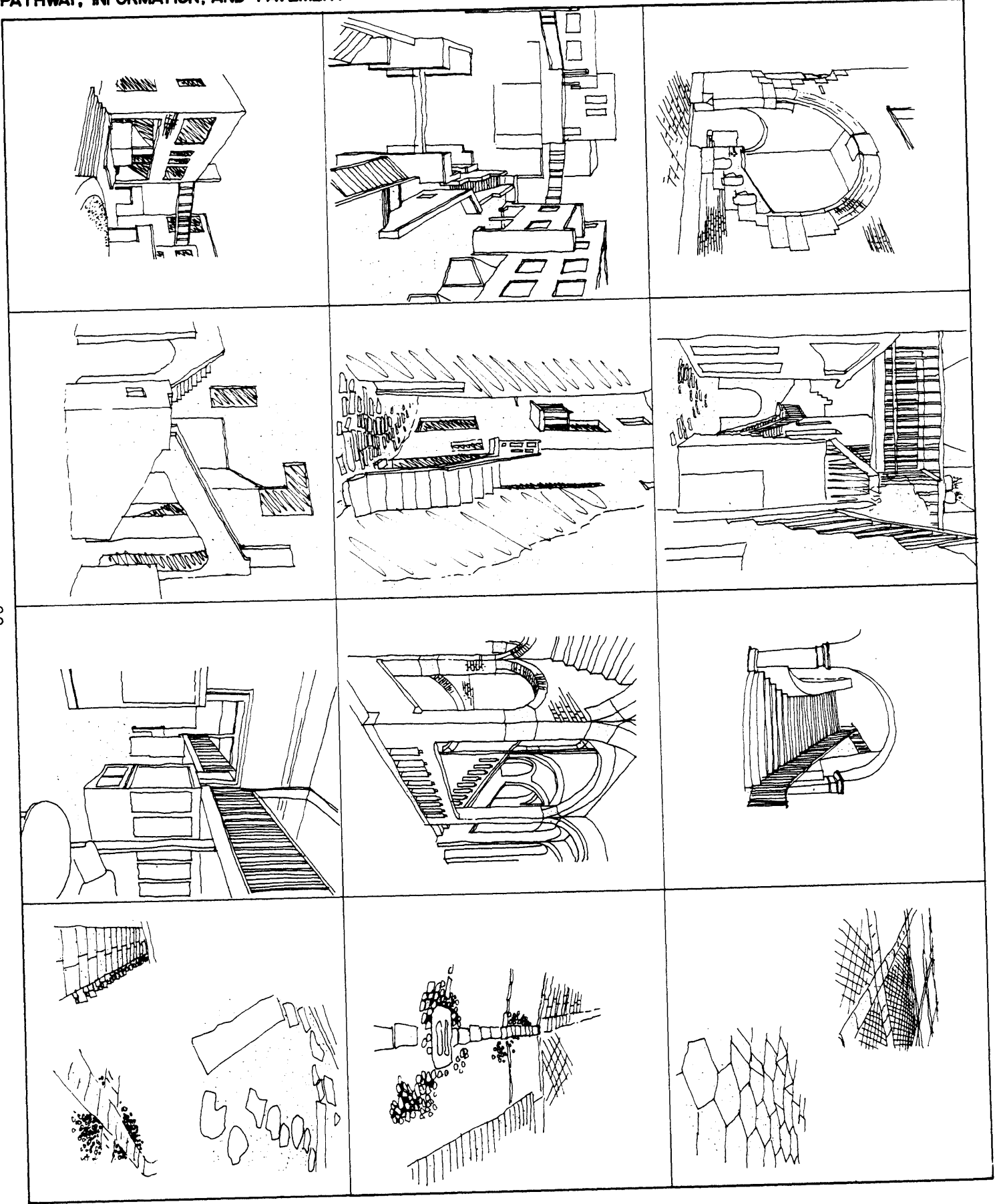

OPTIONS

Options are generated by an inductive and reductive analytical process. Rather than facilitating one design process, the option methodology attempts to provide a variety of settings and choices for exploration. This unrestrictive approach allows for client participation in examining feasible solutions. Coupled with the client participation, the analytical tools and designer's skills can provide a visually stimulating and satisfying environment.

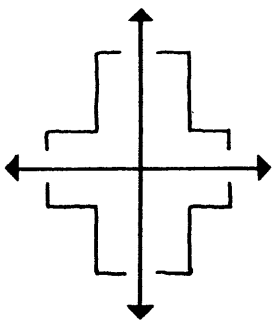
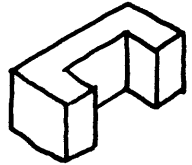
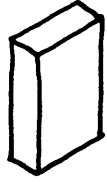
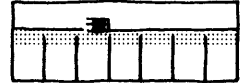
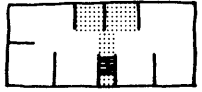
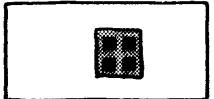
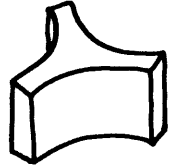
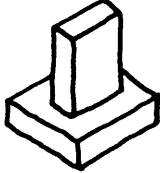
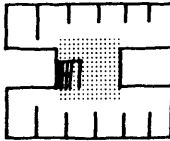
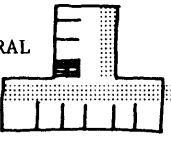
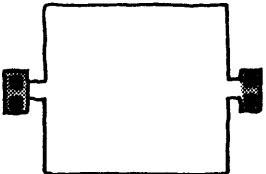
MASSING & ORIENTATION	CLASSIFICATION OF BUILDING SHAPE		CLIMATE CONSIDERATION IN BUILDING	ACCESS WAY
	SLAB	COURT	NO ORIENTATION	
	BENT SLAB	TOWER	UNILATERAL	SERVICE CIRCULATION
			 WEIGHTED 	
RADIAL SLAB	TOWER AND BASE	BILATERAL	SERVICE CIRCULATION	
		 MULTILATERAL 		

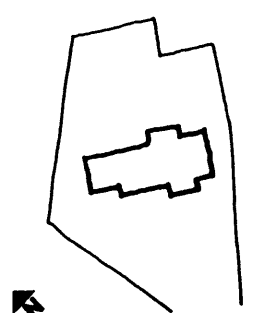
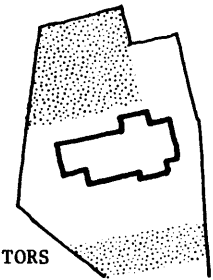
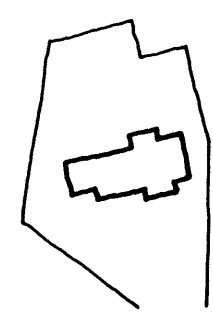
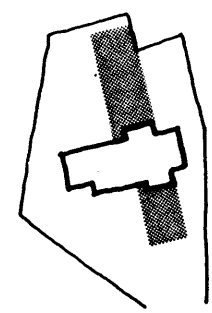
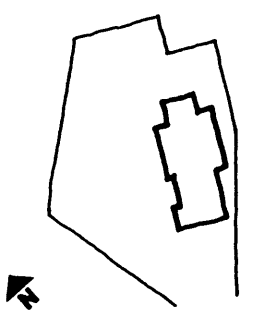
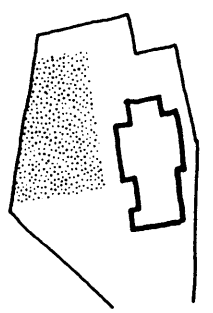
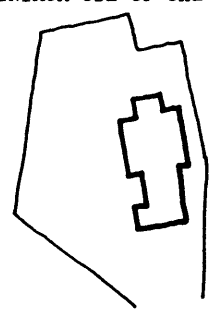
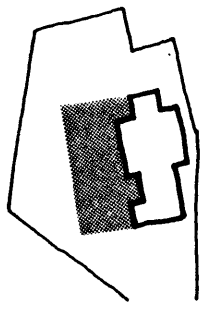
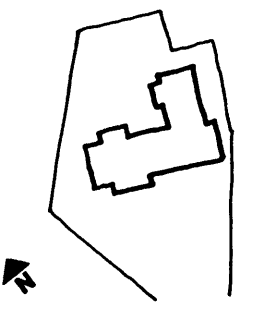
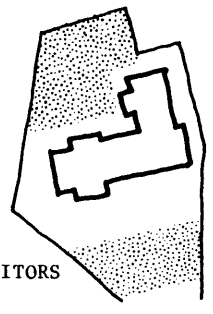
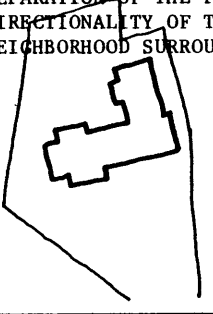
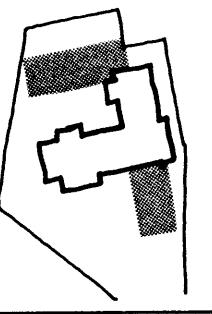
SITE PLANNING	BUILDING LAYOUT	PARKING	ORIENTATION	POSSIBLE EXPANSION
		<p>WORKERS</p>  <p>VISITORS</p>	<p>EXPOSED TO SOUTH</p> 	
		<p>WORKERS & VISITORS</p> 	<p>MASSING ALONG THE STREET MINIMUM USE OF THE LIGHT</p> 	
		<p>WORKERS</p>  <p>VISITORS</p>	<p>ADVANTAGE OF SOUTHERN EXPOSURE SEPARATION OF THE PARKING DIRECTIONALITY OF THE NEIGHBORHOOD SURROUNDING</p> 	

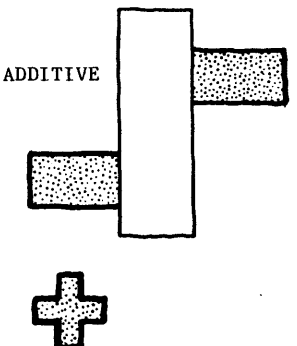
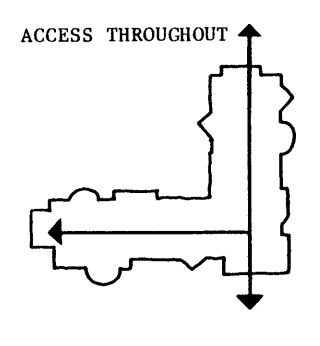
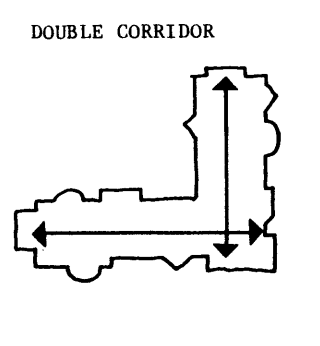
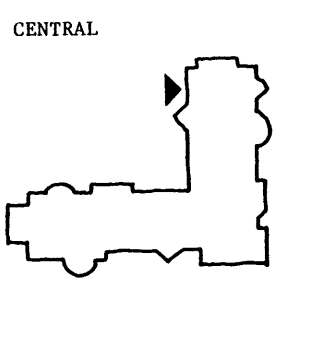
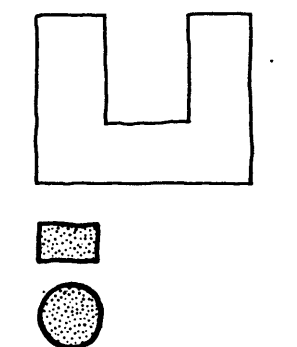
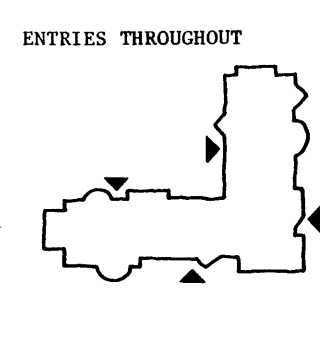
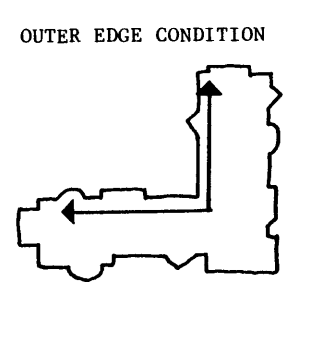
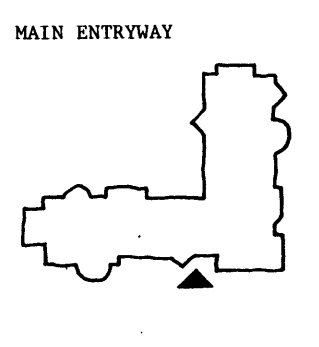
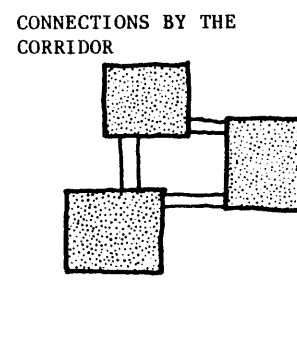
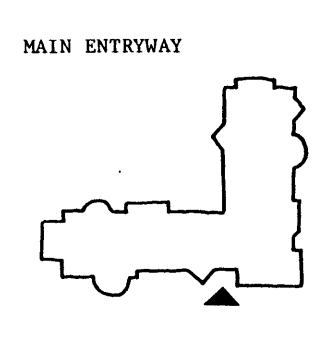
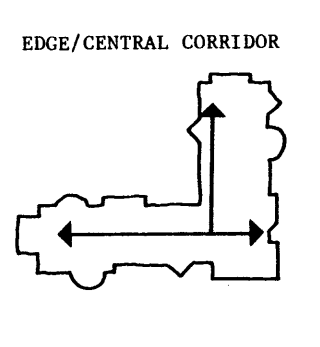
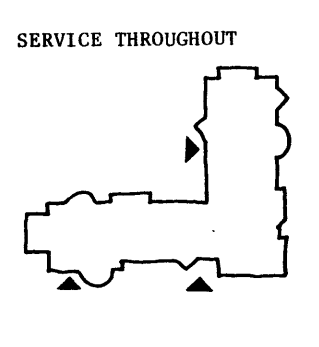
	VOLUMETRIC	ENTRYWAY	CIRCULATION	SERVICE
ORGANIZATION	ADDITIVE 	ACCESS THROUGHOUT 	DOUBLE CORRIDOR 	CENTRAL 
		ENTRIES THROUGHOUT 	OUTER EDGE CONDITION 	MAIN ENTRYWAY 
	CONNECTIONS BY THE CORRIDOR 	MAIN ENTRYWAY 	EDGE/CENTRAL CORRIDOR 	SERVICE THROUGHOUT 

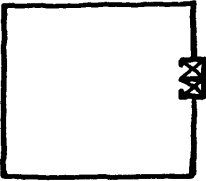
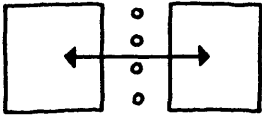
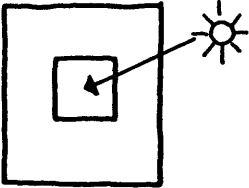
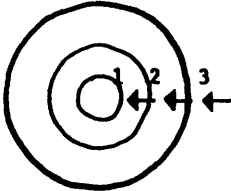
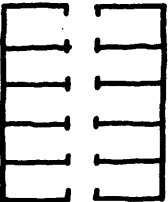
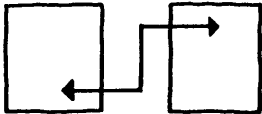
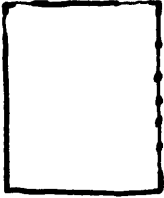
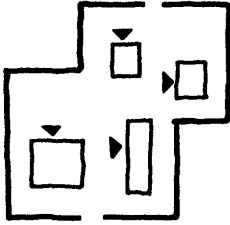
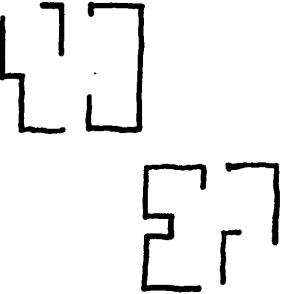
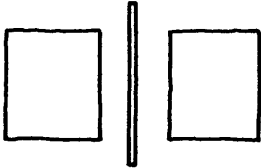
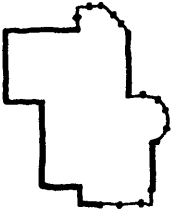
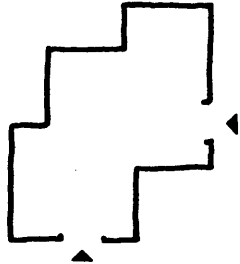
ORGANIZATION	OFFICE SPACES	CIRCULATION THROUGH	LIGHT PENETRATION	SECURITY
	<p>OPEN PLAN OFFICE</p> 	<p>1. ROW OF CLOSELY SPACED COLUMNS, OR WALL WITH OPENINGS</p> <p>2. DIRECT CONNECTION BETWEEN THE SEPARATE SPACES</p> 	<p>OPENING IN THE CENTER</p> 	<p>HIERARCHY</p> 
	<p>CUBICAL</p> 	<p>1. ZONES OF PERMANENT CIRCULATION</p> <p>2. INDIRECT CONNECTION</p> 	<p>CONVENTIONAL HOLE ON THE WALL</p> 	<p>DECENTRALIZED</p> 
	<p>PARTIAL PARTITIONING AND OPEN SPACE</p> 	<p>1. ZONE OF DEFINED ACTIVITY</p> <p>2. INDIRECT CONNECTION</p> 	<p><u>LIGHT ROOM</u> ARTICULATION BY THE DEFINED SPACE</p> 	<p>CONTROLLED AREA</p> 

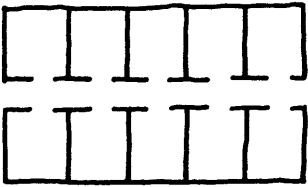
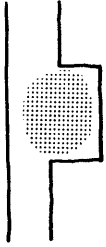
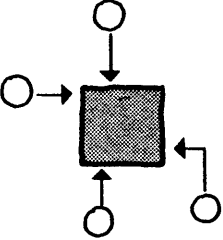
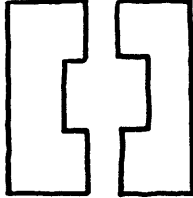
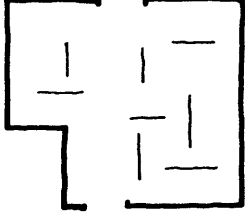
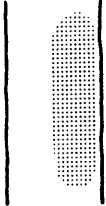
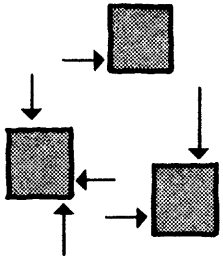
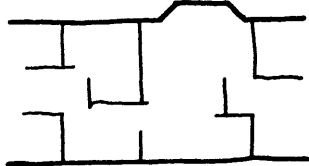
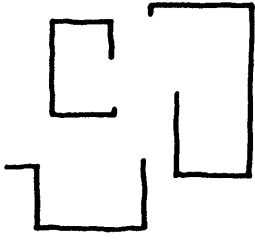
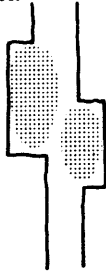
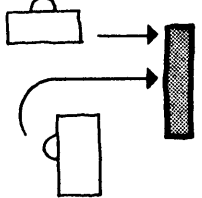
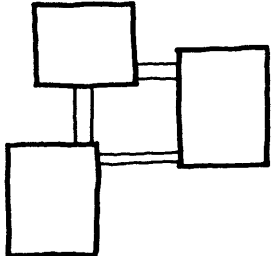

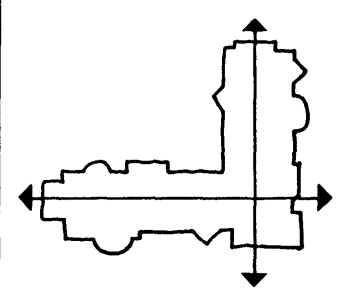
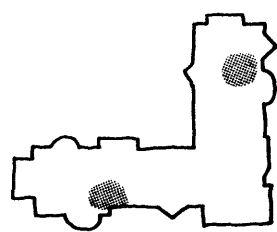
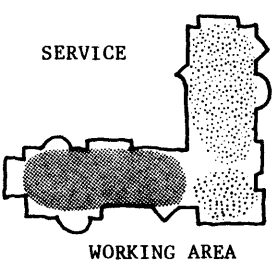
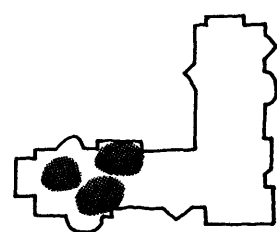
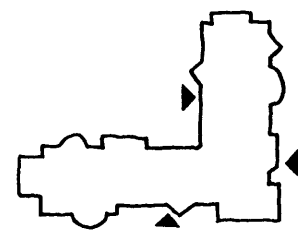
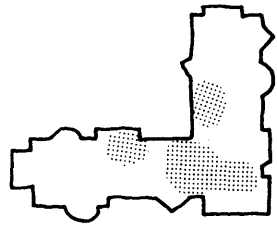
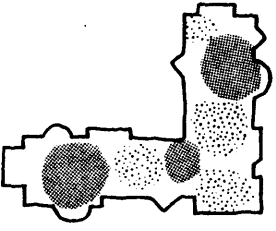
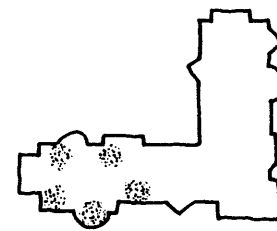
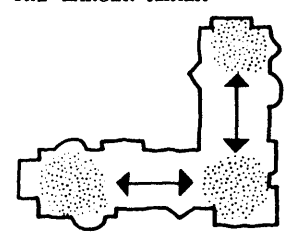
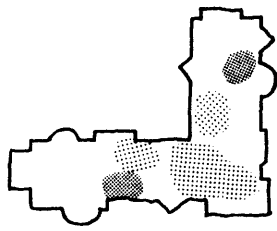
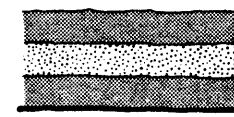
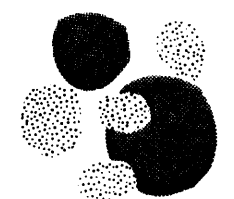

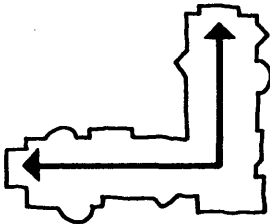
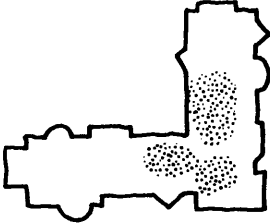
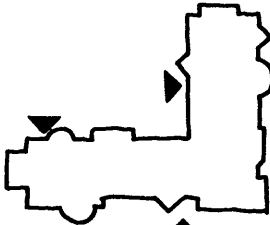
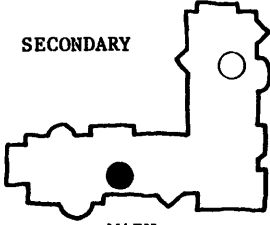
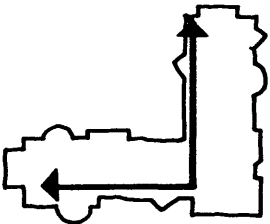
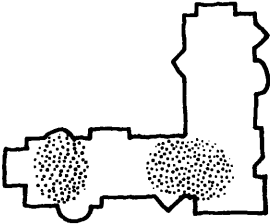
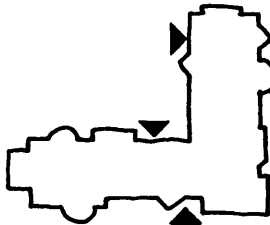
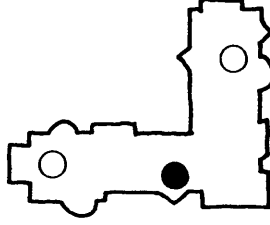
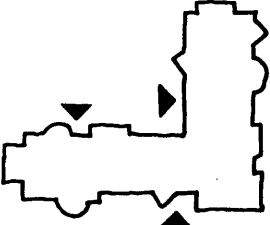
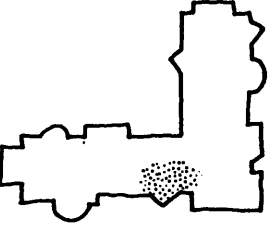
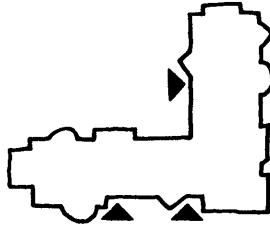
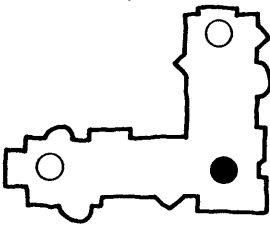

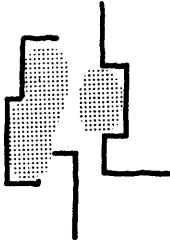
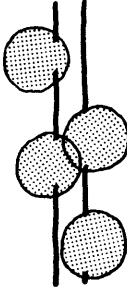
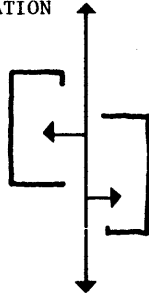
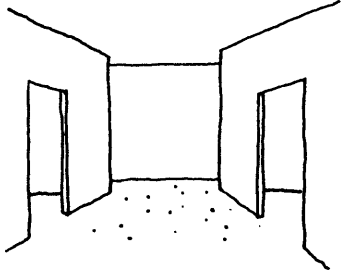
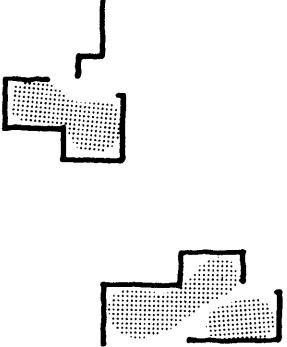
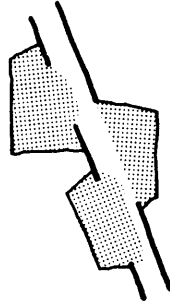
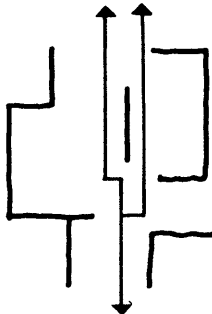
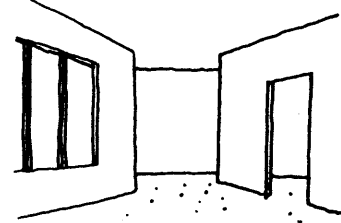
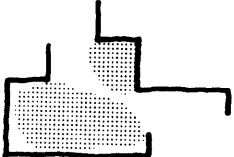
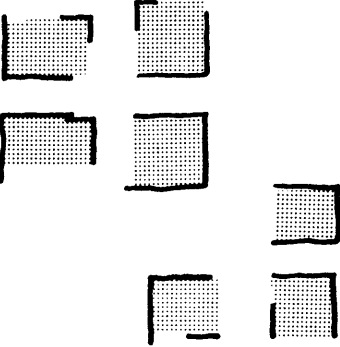
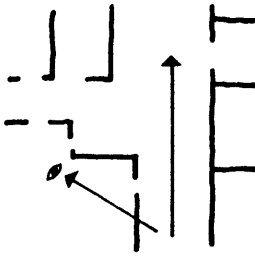
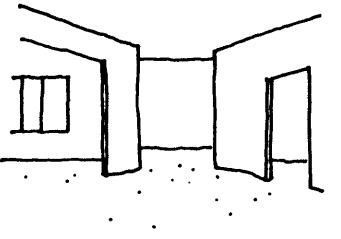
ORGANIZATION	OFFICE LAYOUT	ACTIVITY AREA ALONG THE SPINE	STORAGE SPACE	CIRCULATION
	INDIVIDUAL ROOMS 		CENTRAL 	CENTER ORIENTATION 
	OPEN PLAN/ LANDSCAPE 	ALONG THE CORRIDOR 	SUBDIVIDED THROUGHOUT 	ROOM TO ROOM PATHWAY 
PARTIAL DEFINITION 	SKIPPING ALONG THE CORRIDOR 	IMMEDIATE ADJACENCY 	DECENTRALIZATION 	



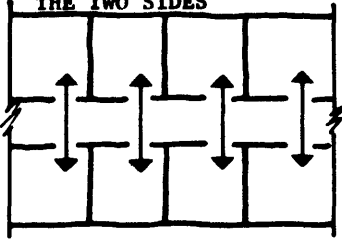
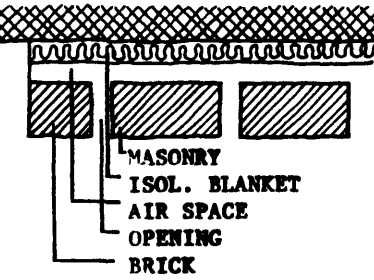

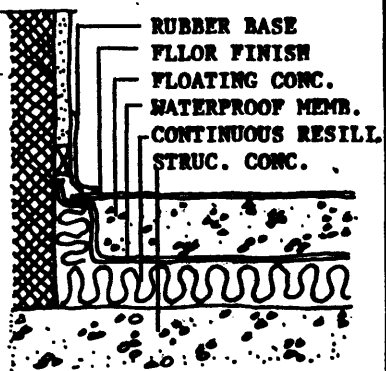
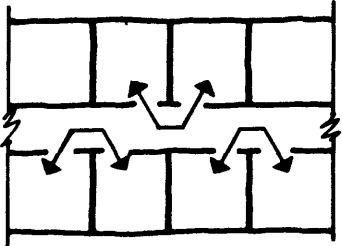
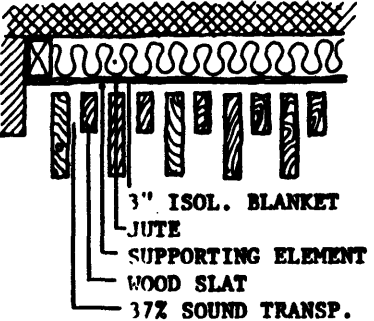
ORGANIZATION	LINKAGE THROUGHOUT	PUBLIC/ PRIVATE	SERVICE & WORK AREA	HALF PRIVATE OFFICE LARGER REALM
		PRIVATE 	SERVICE WORKING AREA 	LARGER REALM 
	ACCESS POINTS 	PUBLIC 	SUBDIVISIONS 	HALF PRIVATE OFFICE • 
RELATIONSHIP WITHIN THE LARGER REALM 	PRIVATE AND PUBLIC INTERACTION 	INTERVAL BETWEEN FLOOR 1ST FL. - WORK AREA 2ND FL. - SERVICE 		

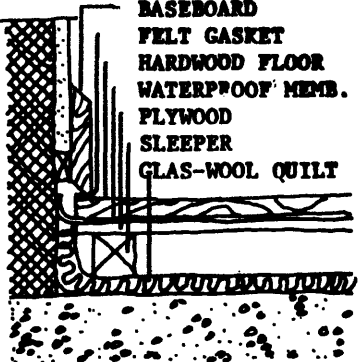
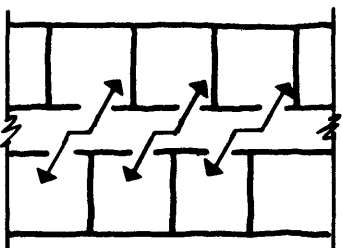
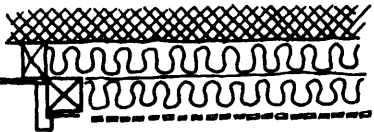
	CIRCULATION	PUBLIC REALM	ENTRYWAY	VERTICAL ACCESS
CIRCULATION	<p>CENTER SPINE MINIMUM LIGHT PENETRATION</p> 	<p>ACTIVITIES GENERATED ALONG THE PATH</p> 		<p>SECONDARY</p>  <p>MAIN</p>
	<p>PATH ALONG THE SPINE VISUAL ACCESSIBILITY LIGHT</p> 	<p>CENTRAL COURT SCHEME MINIMUM INTERACTION ALONG THE PATH</p> 		
	<p>ENTRYWAY CIRCULATION</p> 	<p>CIRCULATION DEFINED BY ENTRYWAY</p> 		

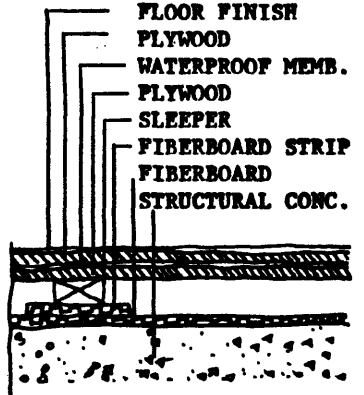
PUBLIC & PRIVATE SPACE ALONG THE PATH	PUBLIC / PRIVATE	POCKETS	INFORMATION/CHOISE	CORRIDOR
			ACTIVITY ALONG THE CIRCULATION 	DOUBLE CORRIDOR 
			PARTIAL DEFINITIONS 	OUTLOOK LIGHT PENETRATION 
		OUTLOOK CLEAR DESTINATION 	ACTIVITY ALONG THE PATHWAY 	

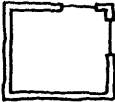
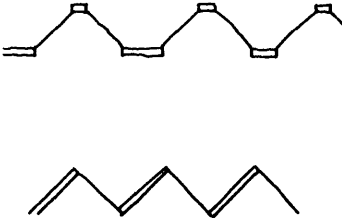
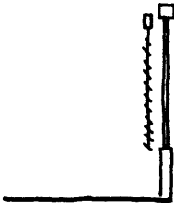
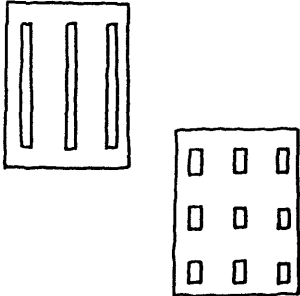
ACOUSTICS	RESILIENT ATTACHMENT IN MULTIPLE WALL	DOOR STOP	AUTOMATIC DROP-BAR	NOISE TRANSMISSION
		PLANS GASKETED DOOR STOP	SECTIONS SURFACE-MOUNTED	STRUCTURAL SLAB DUCT SUSPENDED CEILING PARTITION WALL SLAB
		 DOUBLE-GASKETED DOOR	 MORTISED SINGLE DROP-BAR	 ALUMN. FOIL ISOL. BLANKET
	 ADJUSTABLE DOOR STOP	 MORTISED DOUBLE DROP-BAR		

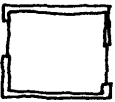
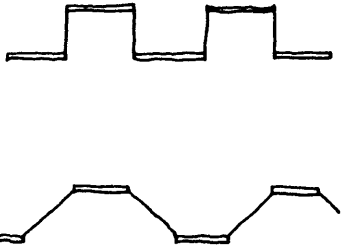
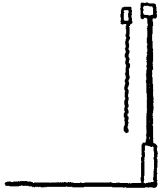
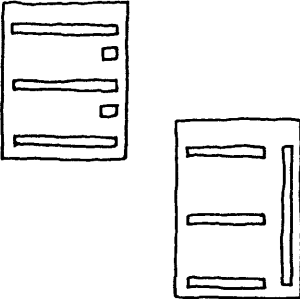
ACOUSTICS	STAGGERED	CEILING SOUND ABSORPTION	FLOATING FLOOR	
	<p>POOR: CONTRIBUTE EFFECTIVELY TO THE ACOUSTICAL PRIVACY OF OCCUPANCIES LOCATED ALONG THE TWO SIDES</p> 	 <p>MASONRY ISOL. BLANKET AIR SPACE OPENING BRICK</p>	<p>ACOUSTICAL TILE CEMENTED TO PLASTER, PLASTERBOARD OR CONCRETE CEILING</p>  <p>ACOUSTICAL TILE NAILED TO WOOD FURRING</p> 	 <p>RUBBER BASE FLOOR FINISH FLOATING CONC. WATERPROOF MEMB. CONTINUOUS RESIL. STRUC. CONC.</p>
	<p>IMPROVED</p> 	 <p>3" ISOL. BLANKET JUTE SUPPORTING ELEMENT WOOD SLAT 37% SOUND TRANSP.</p>	<p>PERFORATED FACING FASTENED TO WOOD FURRING</p>  <p>SOUND-ABSORBING MATERIAL ATTACHED TO SHEET METAL</p> 	 <p>BASEBOARD FELT GASKET HARDWOOD FLOOR WATERPROOF MEMB. PLYWOOD SLEEPER GLAS-WOOL QUILT</p>
<p>IMPROVED</p> 		<p>CEILING ACOUSTICAL TILE SUPPORTED BY SUSPENSION</p>  <p>PERFORATED FACING FASTNED TO WOOD FURRING</p> 	 <p>FLOOR FINISH PLYWOOD WATERPROOF MEMB. PLYWOOD SLEEPER FIBERBOARD STRIP FIBERBOARD STRUCTURAL CONC.</p>	

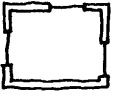
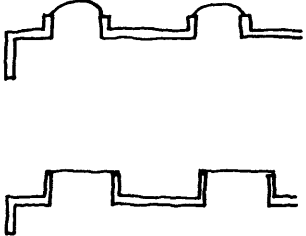
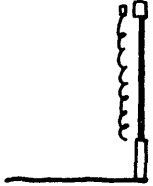
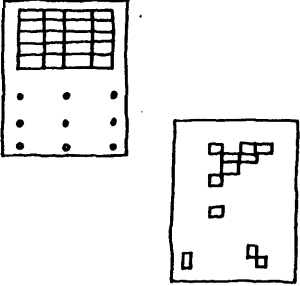
LIGHTING	MUTILATERAL LIGHTING		ROOF LIGHTING	INTERIOR DEVICE	LIGHT DISTRIBUTION
	SECTIONS	PLANS		VENETIAN BLINDS	
					
			DRAPER BLINDS-VERTICAL		
			ROLL SHADES		

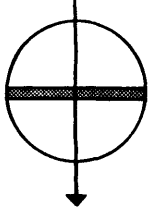
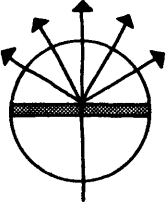
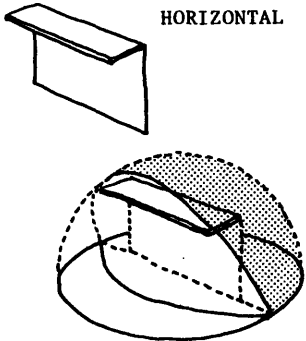
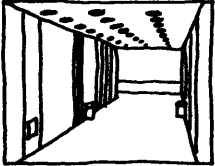
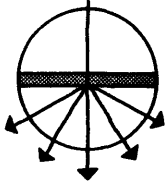
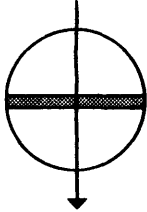
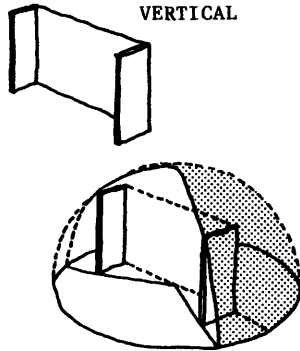
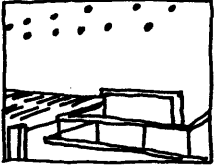
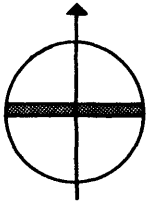
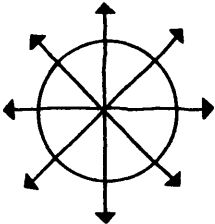
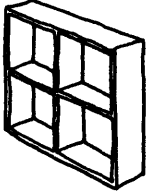
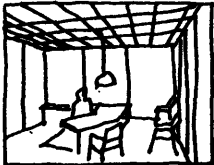
LIGHTING	LIGHTING ARTIFICIAL		BASIC TYPES OF SHADING DEVICES	LUMINAIRE DISTRIBUTION
	DOWNWARD CONCENTRATING 	UPWARD DIFFUSING 	HORIZONTAL 	CONCENTRATED DISTRIBUTION HIGH REFLECTANCE FINISHES 
	DOWNWARD DIFFUSING 	MULTI-DIRECTIONAL CONCENTRATING 	VERTICAL 	DIFFUSE DISTRIBUTION HIGH REFLECTANCE FINISHES 
	UPWARD CONCENTRATING 	MULTI-DIRECTIONAL DIFFUSING 	EGGCRATE 	CONCENTRATED DISTRIBUTION LOW REFLECTANCE FINISHES 

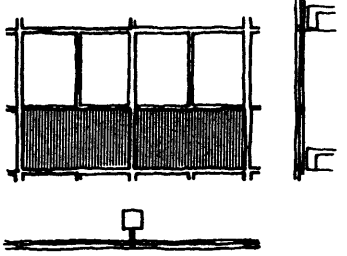
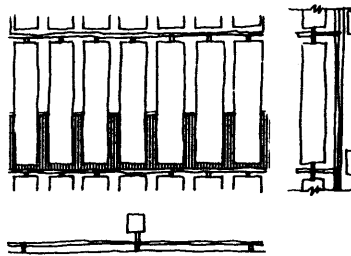
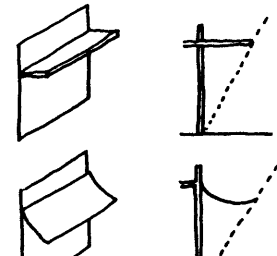
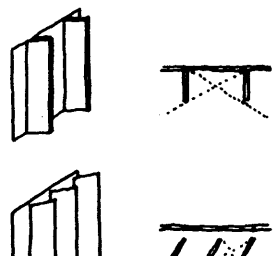
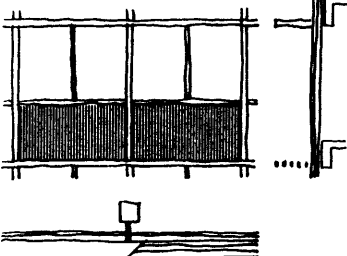
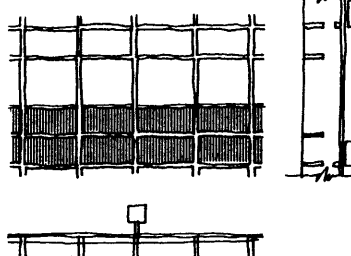
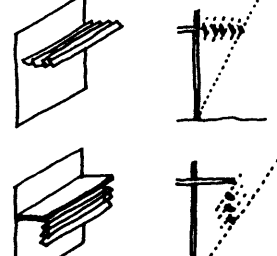
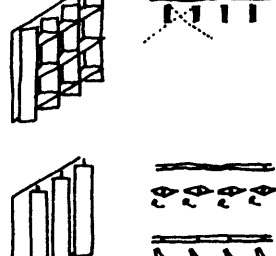
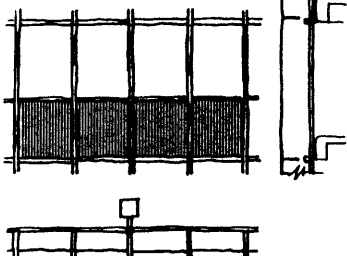
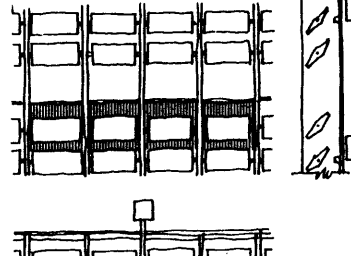
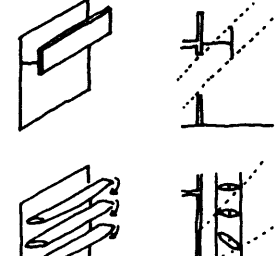
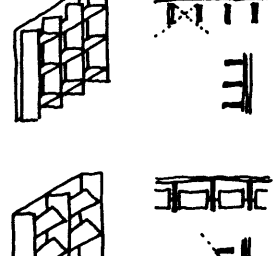
		SHADING DEVICES		HORIZONTAL		VERTICAL	
SHADING SCREENS	CURTAIN WALL		VERTICAL MOVABLE				
	HORIZONTAL DEVICE		FIXED EGGRATE				
	VERTICAL FIN		MOVABLE EGGRATE				

<p>FACADE PATTERNS</p>	<p>STRUCTURAL FRAME</p>	<p>FRAMING AND PANELS</p>	<p>STATIC</p>	<p>STATIC</p>
	<p>WINDOW ARRANGEMENT</p>	<p>LOUVRES AND OTHER SOLAR SCREENS</p>	<p>VERTICAL</p>	<p>HORIZONTAL</p>
	<p>COMPONENT ASSEMBLIES</p>	<p>REPEATED PLAN UNITS</p>	<p>HORIZONTAL</p>	<p>DIRECTION</p>

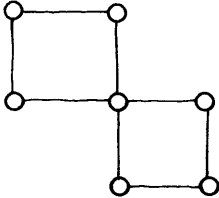
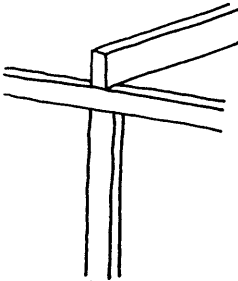
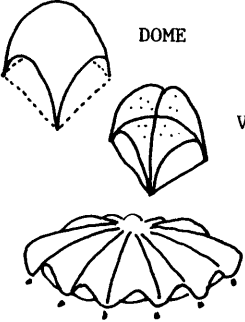
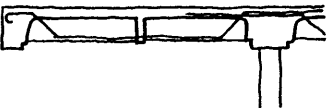
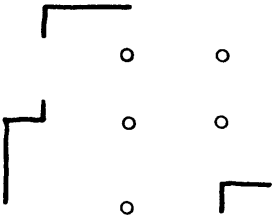
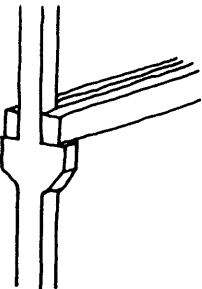
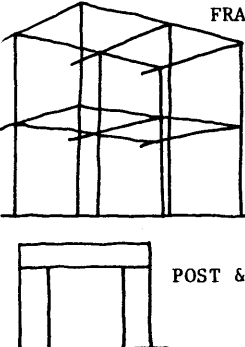
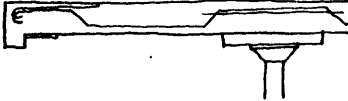
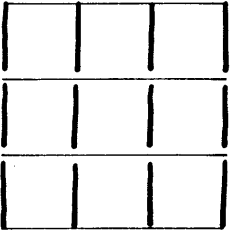
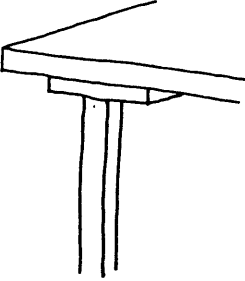
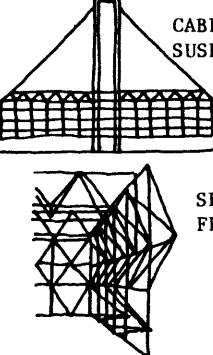
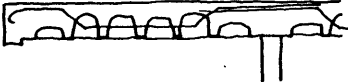
STRUCTURE	VERTICAL SUPPORT	COLUMNS	BUILDING TYPES	CONCRETE FL. SYSTEMS
	<p data-bbox="431 320 517 340">COLUMNS</p> 		 <p data-bbox="1278 307 1327 327">DOME</p> <p data-bbox="1374 394 1438 414">VAULT</p> <p data-bbox="1264 621 1391 640">MONOLITHIC</p>	<p data-bbox="1523 307 1796 327">ONE WAY CONCRETE JOIST</p> 
	<p data-bbox="431 693 725 713">COLUMNS AND BEARING WALL</p> 		 <p data-bbox="1336 682 1412 702">FRAMED</p> <p data-bbox="1300 943 1461 963">POST & LINTOL</p>	<p data-bbox="1523 707 1817 753">TWO WAY FLAT SLAB-SQUARE BAY</p> 
	<p data-bbox="431 1070 602 1090">MODULAR SYSTEM</p> 		 <p data-bbox="1300 1083 1412 1129">CABLE SUSPENDED</p> <p data-bbox="1321 1257 1391 1303">SPACE FRAME</p>	<p data-bbox="1506 1083 1796 1129">WAFFLE FLAT SLAB-SQUARE BAY</p> 

DESIGN PROCESS

- 1 ST Part: General organization of the building and massing. Familiarization with the setting and the contextual relationship of the building to its neighborhood.
Implementation of workers' feedback and research findings.
- 2 ND Part: Closer examination of the surrounding entryway, reception area and immediate work area.
- 3 RD Part: Three dimensional exploration. Study of level changes, structural system - columns and bearing walls, windows, massing, and their relationships to the entryway.
- 4 TH Part: Articulation of the plan. Continuation of the evaluation of windows and their relationship to the massing.

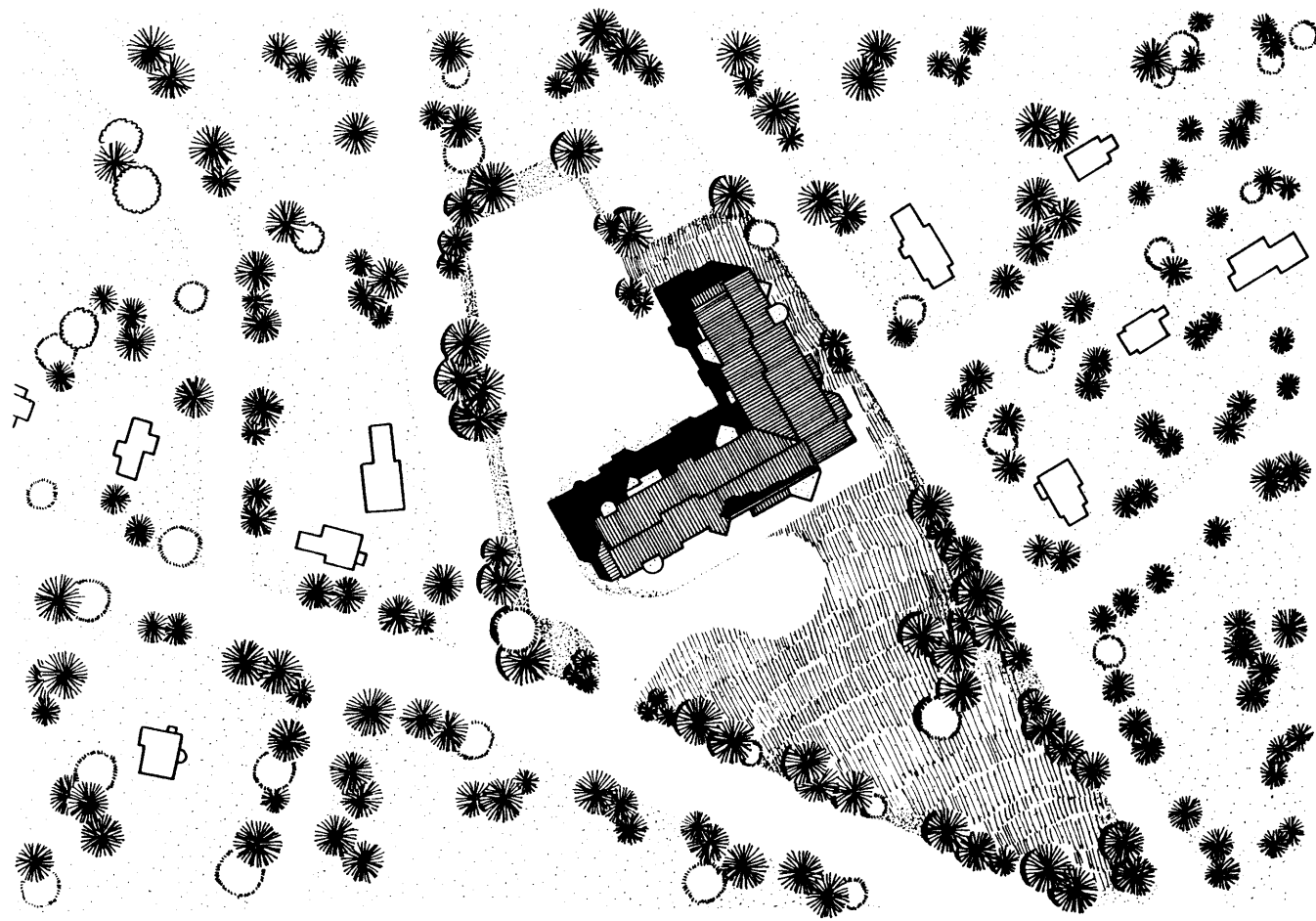

20 40 80 FT

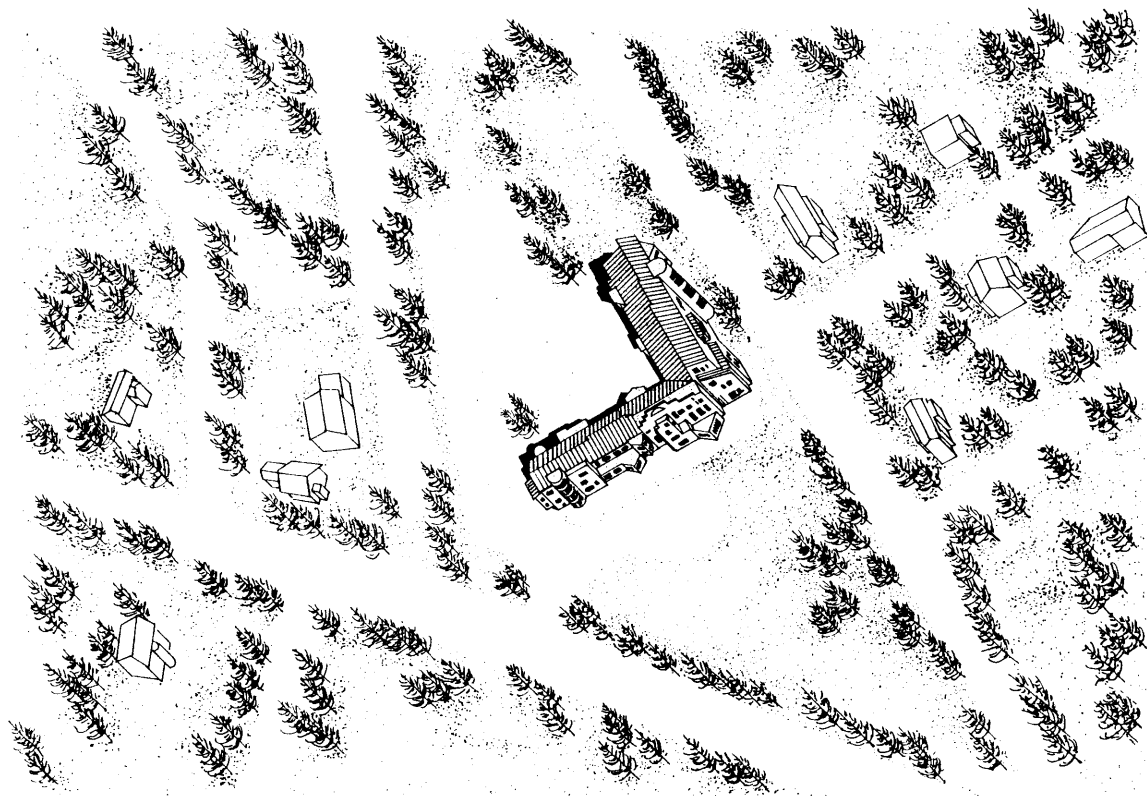

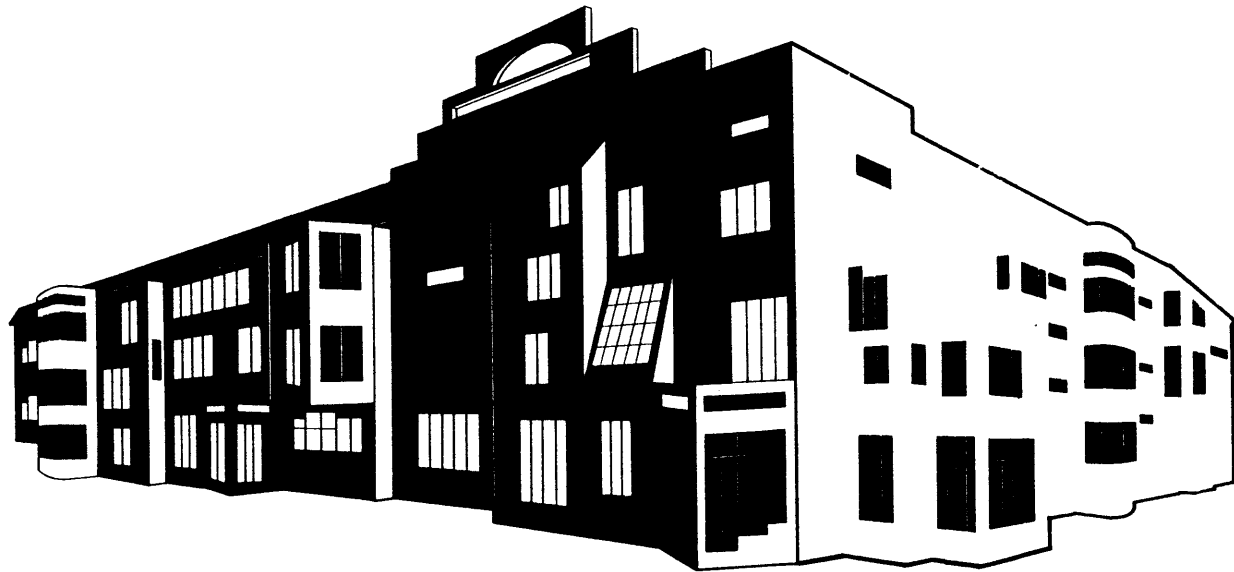

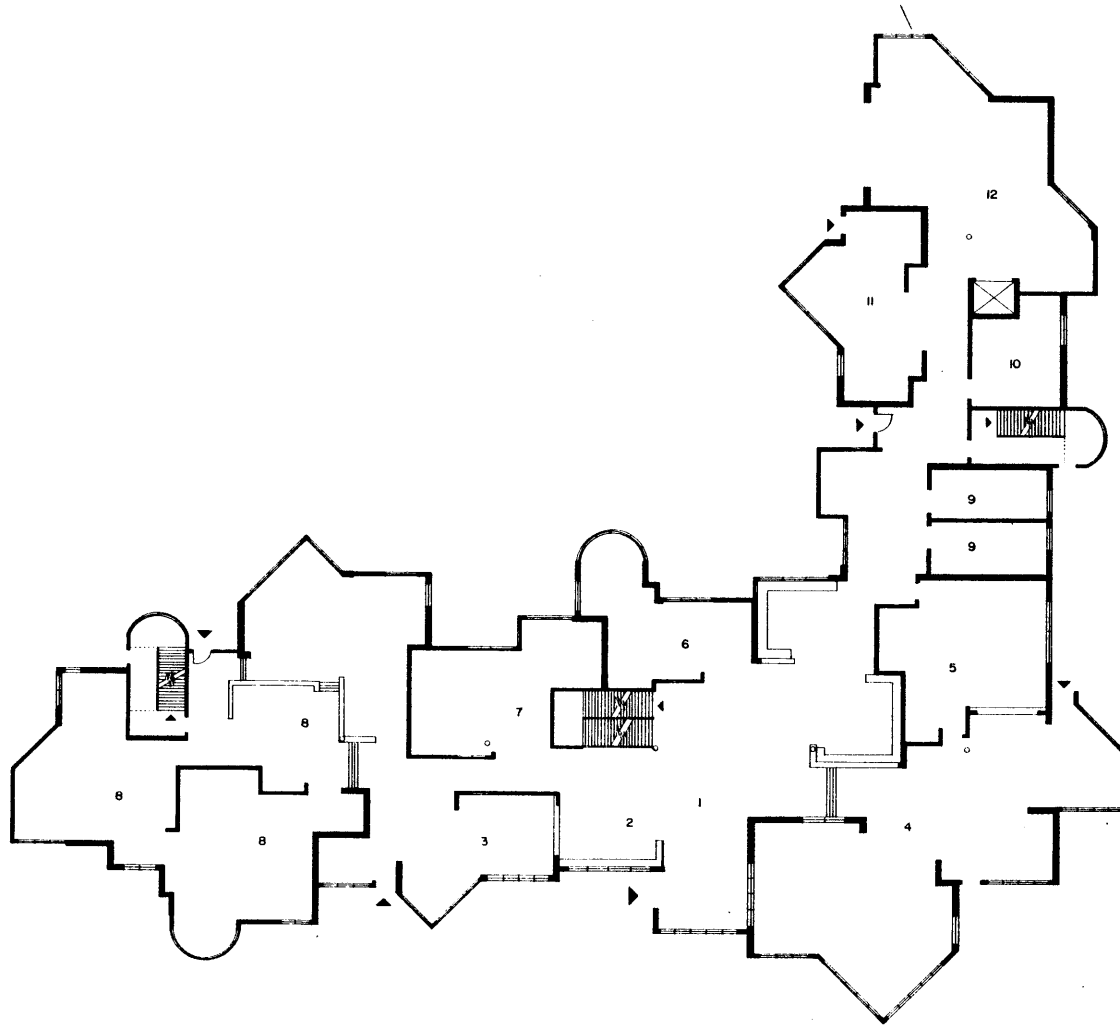

FIRST FLOOR

- 1 LOBBY
- 2 WAITING
- 3 RECEPTION
- 4 EATING AREA
- 5 KITCHEN
- 6 LOUNGE
- 7 ADJUSTMENT
- 8 OFFICE
- 9 W. C.
- 10 MECHANICAL
- 11 MAIL RM.
- 12 RECEIVING

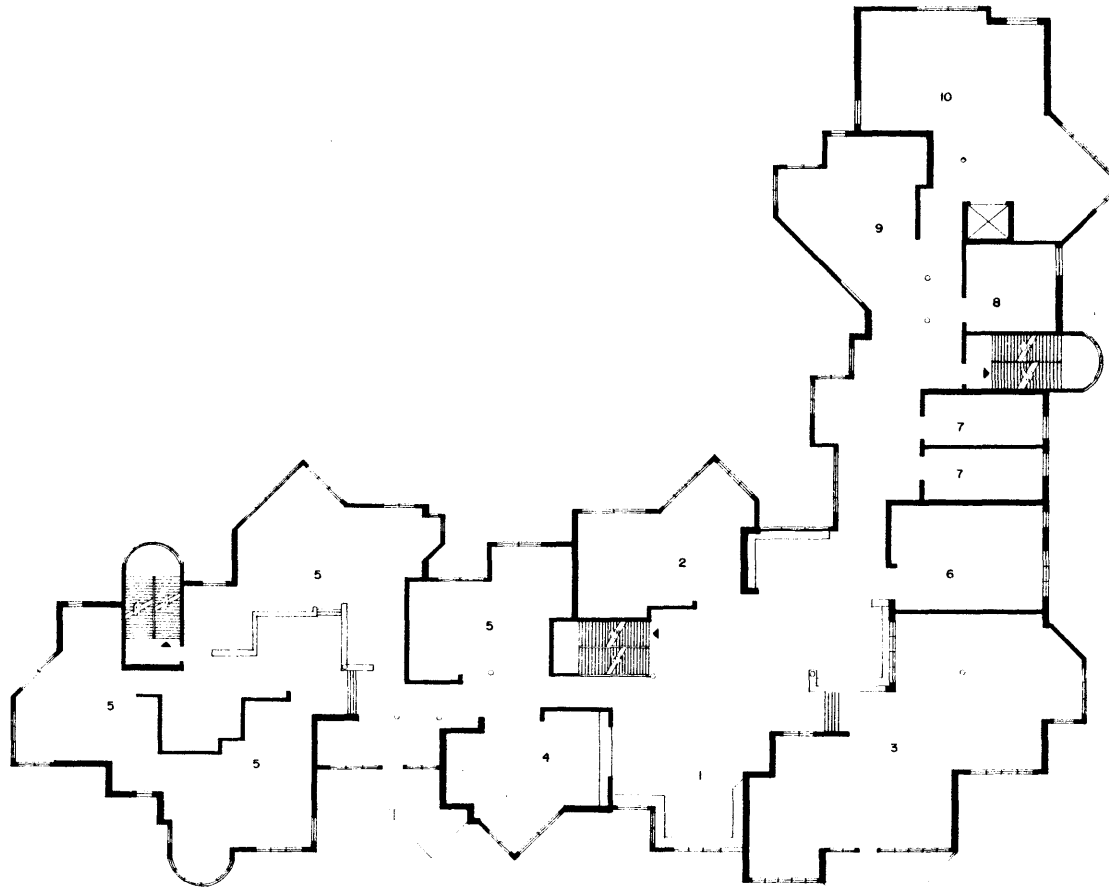

SECOND FLOOR

- 1 WAITING
- 2 LOUNGE
- 3 LIBRARY
- 4 BENEFIT ADMINISTRATION
- 5 OFFICE
- 6 CONFERENCE
- 7 W. C.
- 8 MECHANICAL
- 9 DATA / COMPUTER SERVICE
- 10 STORAGE

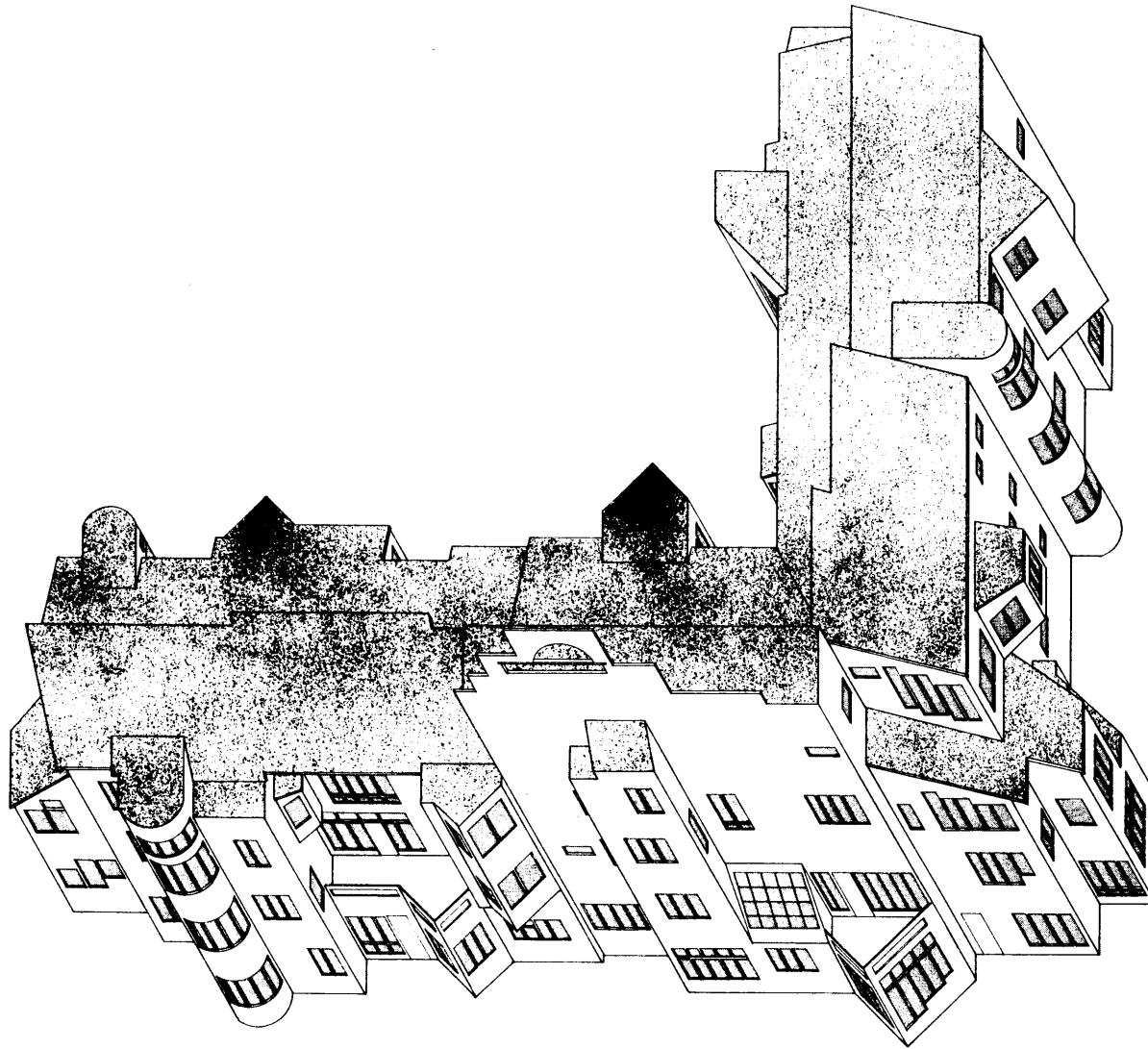

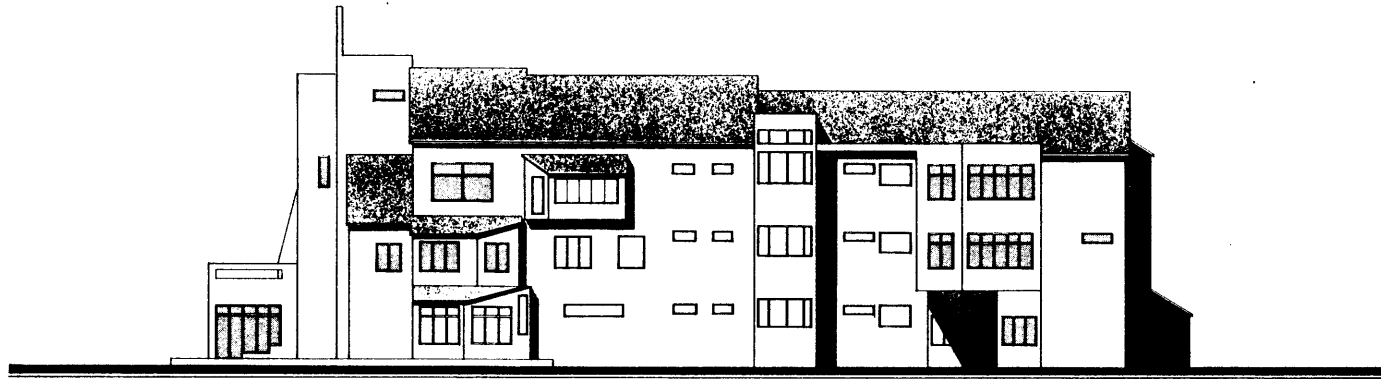

S. E. ELEVATION



S. W. ELEVATION

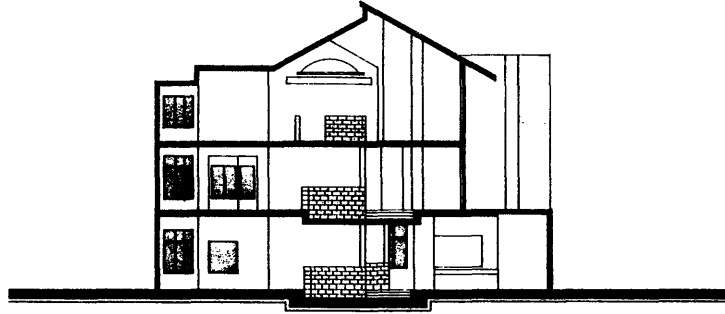

SECTION A-A

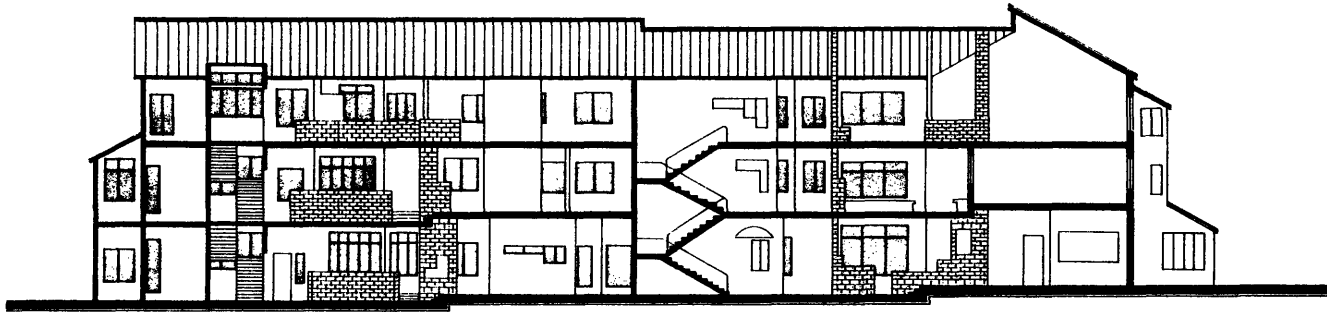
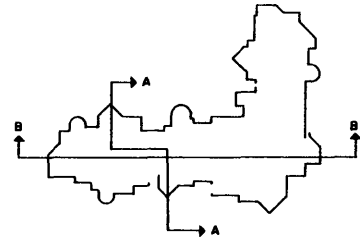

SECTION B-B

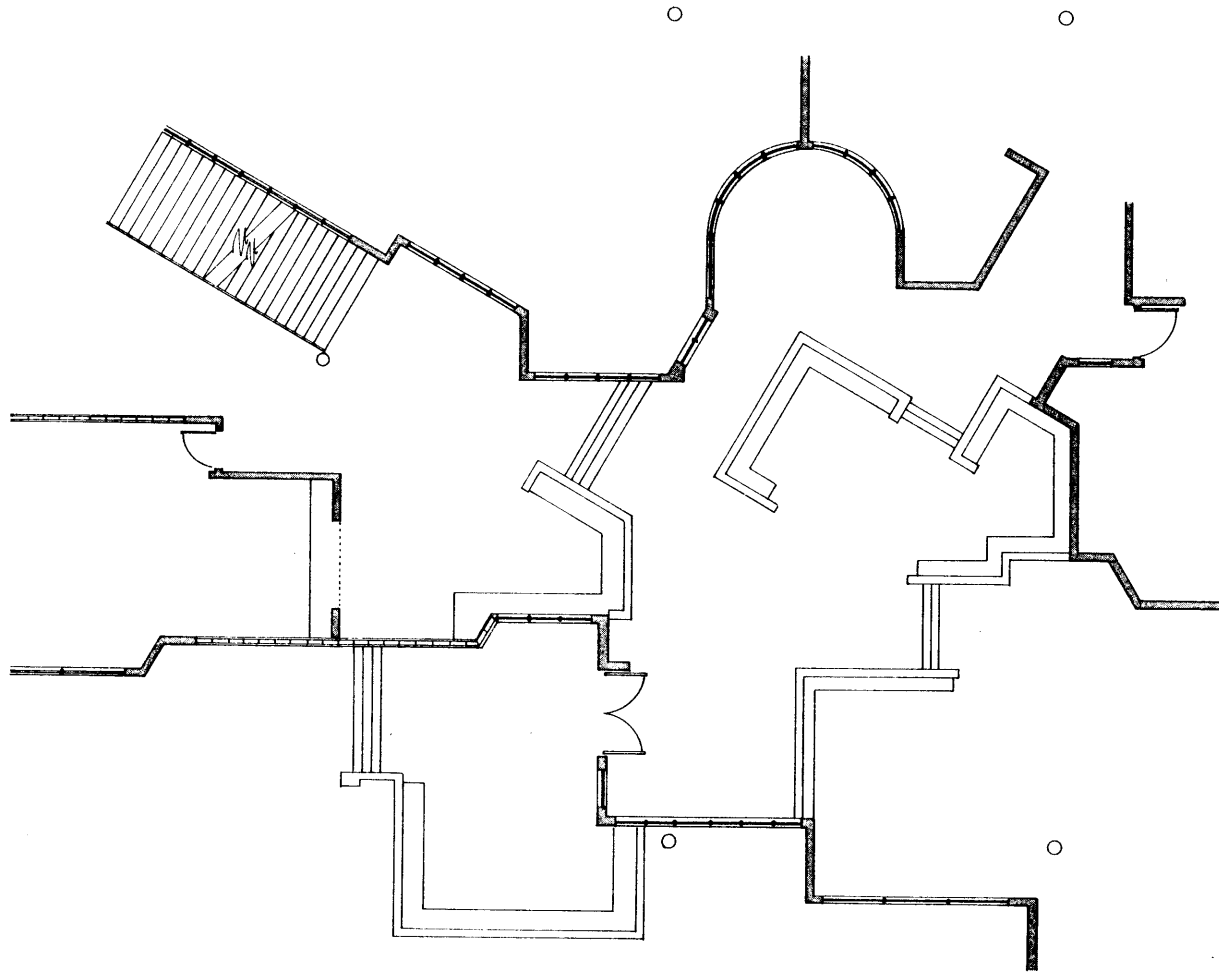

ENTRY WAY & ADJACENCY

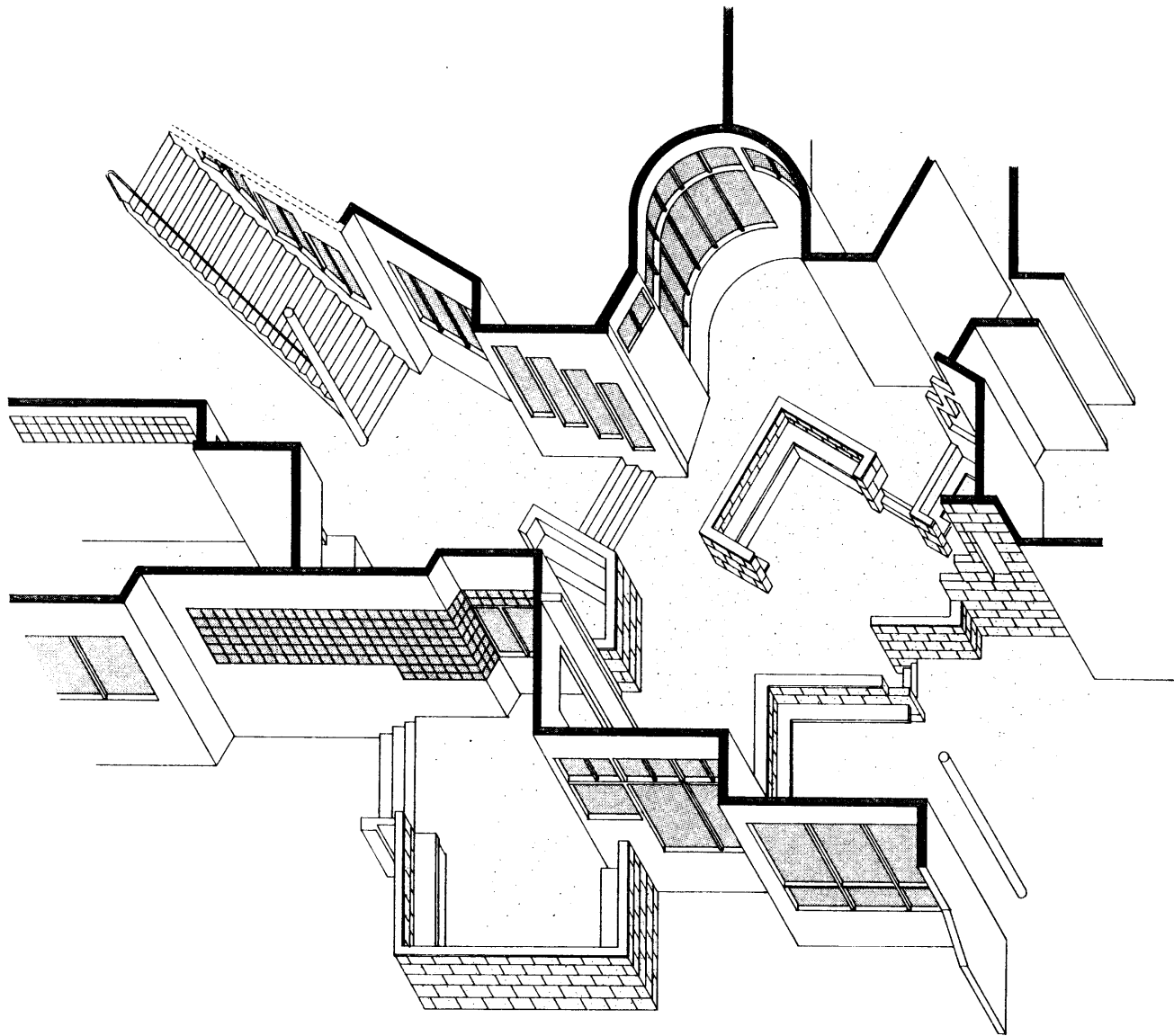

ENTRY WAY & ADJACENCY

COLUMNS

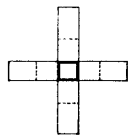
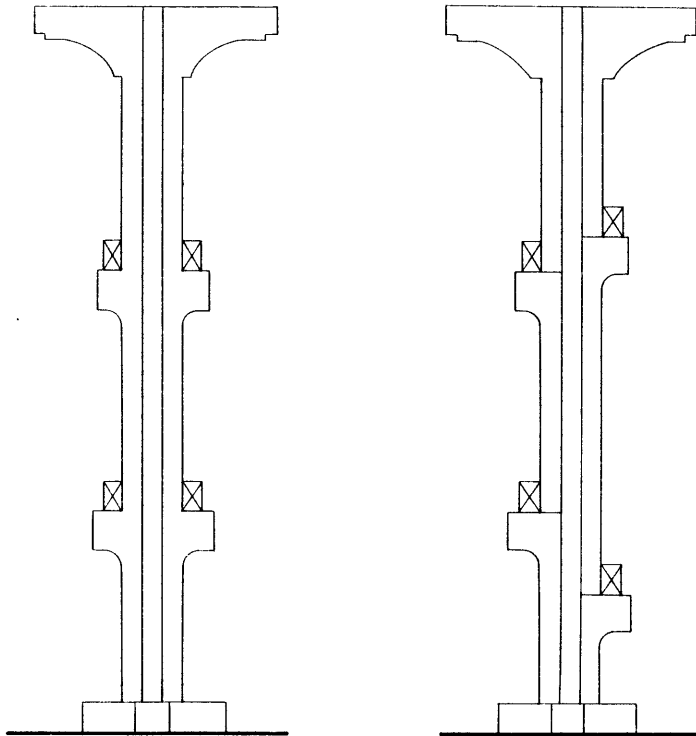

1 3 6 FT.

VERTICAL LAYOUT

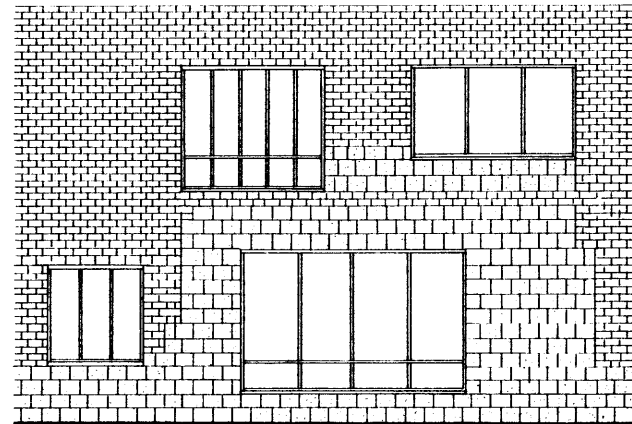

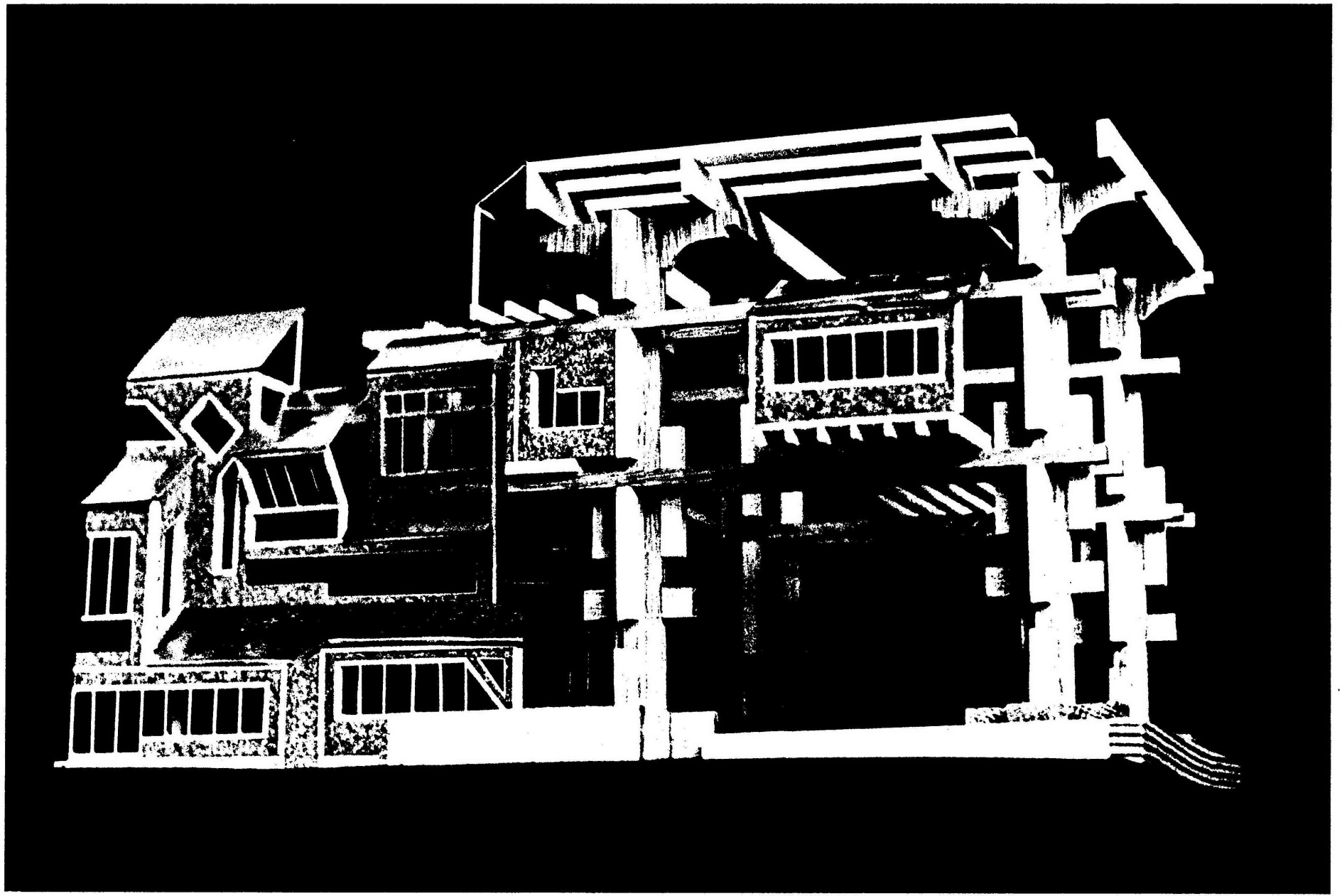

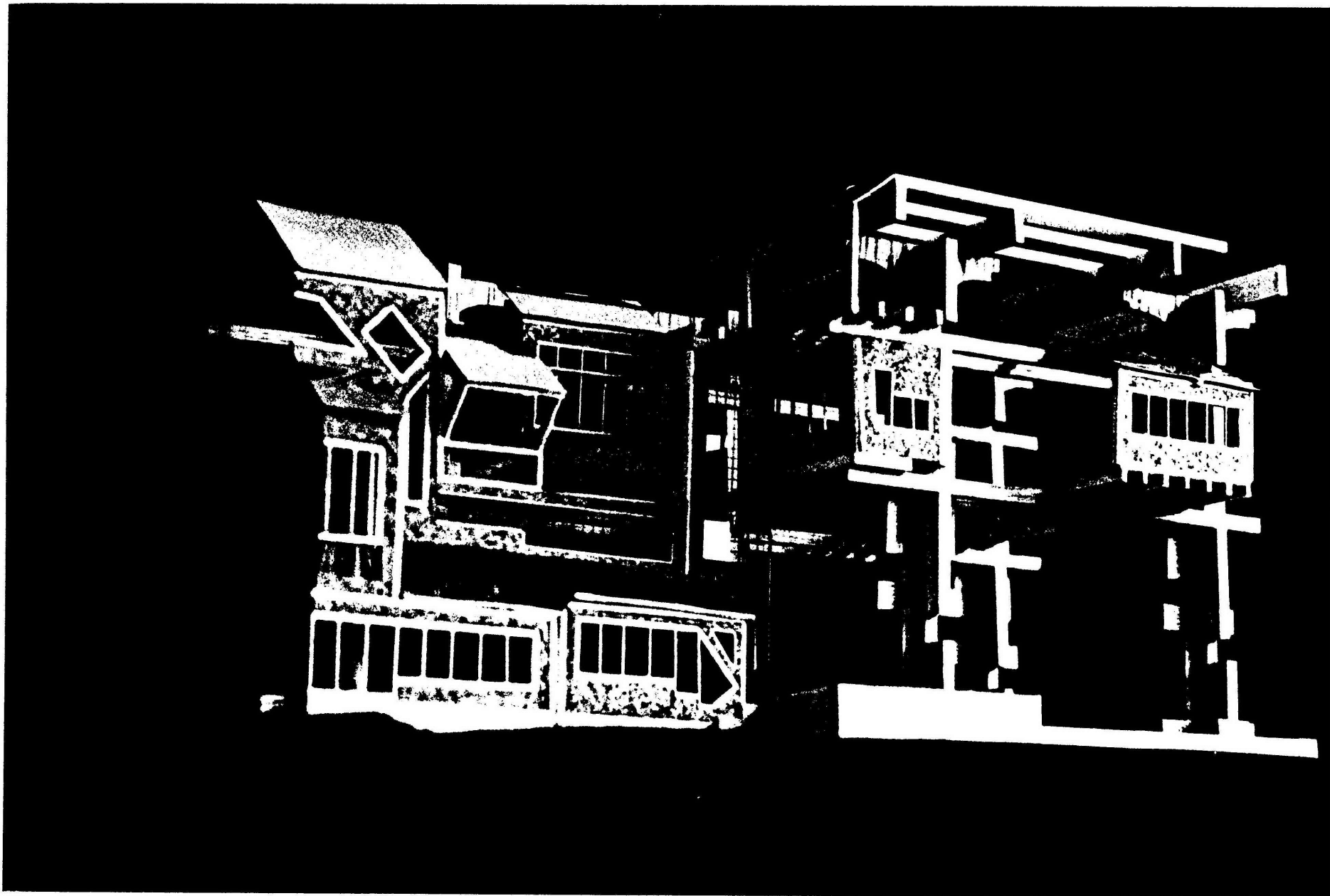

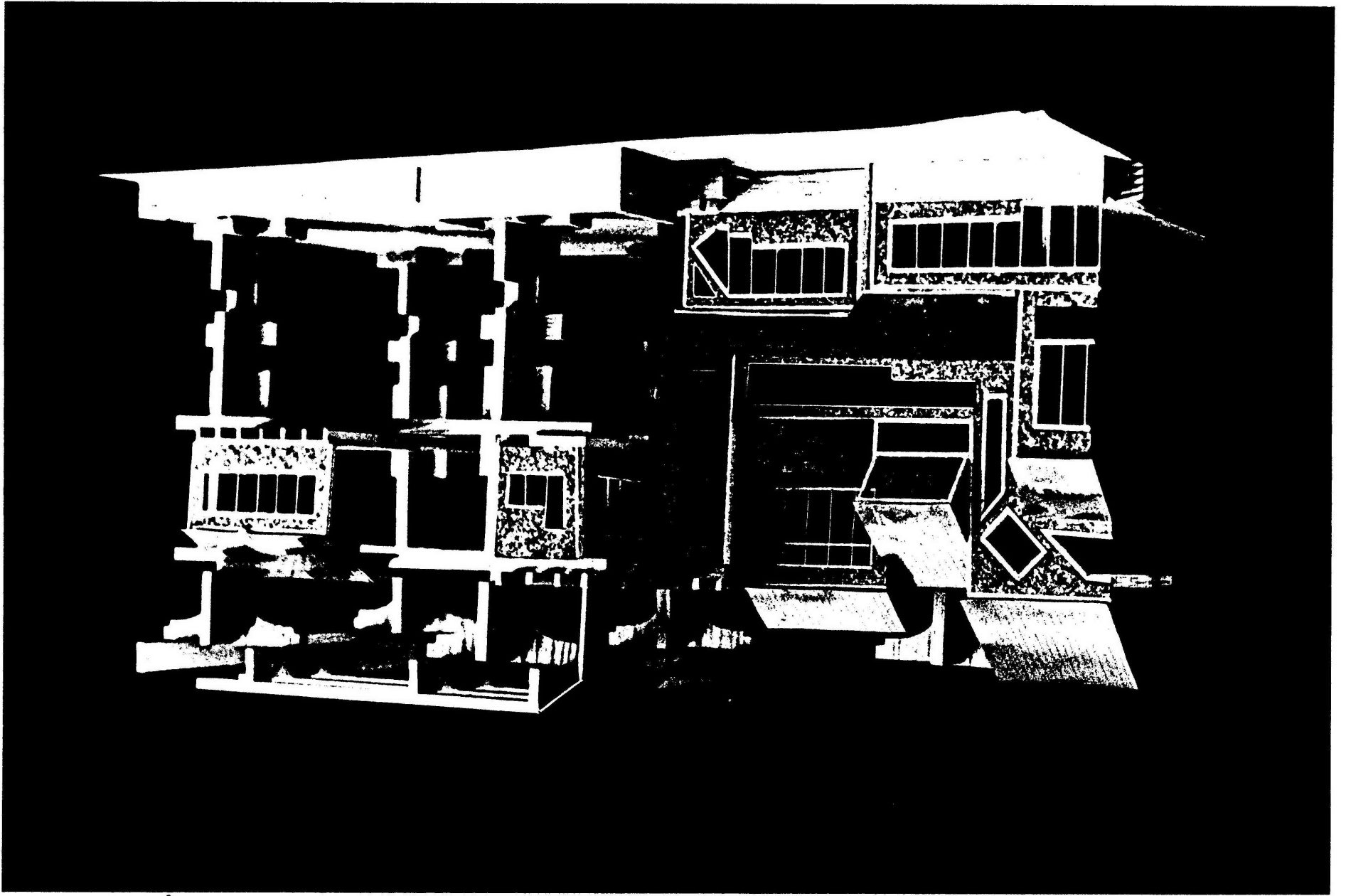

SUMMARY

The levels of participation in this design thesis have been articulated in two parts:

1. A comprehensive exploration into the needs and desires of the various user-individuals; and,
2. The completion of four levels of articulation - organization, detail, model, detail-organization in plan.

The examination of variables influencing the work environment has provided opportunities for testing design vocabularies and spatial configurations. At this initial design completion, new perspectives in reorganizing, restructuring, redesigning the building have evolved. It would be desirable to apply these new concepts into the original plan and begin the examination anew.

Design is, thus, a continuous learning process. The knowledge and experience gained from this study will be modified and built upon in future applications.

BIBLIOGRAPHY

1. J. Pile
Interior 3Rd Book of Office , P. 16
Watson-Guptil Publication, N.Y. 1976
2. M. Slezak
White-Collar Workplace, P. 7
M. Arch. Thesis 1978 - M.I.T.
3. H.R. Hitchcock
Larkins Company Administration Building
In The Natural Materials, P.P. 92-99
Duell, Sloan, Pearce, N.Y. 1942

Johnson Wax Company
Frank Lloyd Wright: Public Buildings, P.P. 15-23
Simon and Schuster, N.Y. 1970
4. Oswald Grube
100 Years of Architecture in Chicago
Philip O'Hara, Chicago 1973
5. Upjohn Institute for Employment Research
Work in America, P. 19
M.I.T. Press
6. Alvin Palmer
Planning the Office Landscape, P.P. 17-82
McGraw-Hill, 1977

Michael Saphier
Planning the New Office, P.P. 47-114
McGraw-Hill, 1978
7. Robert Quinn
Locking-In as a Moderator of the Relationship Between Job Satisfaction and Mental Health
University of Washington, 1972

8. Irwin Altman
The Ecology of Isolated Groups, P.P. 226-239
"Environmental Psychology: Man and His Physical Setting"
Holt, Rinehart and Winston Inc., 1969
9. S.M. Lyman & M.B. Scott
Territoriality: A Neglected Sociological Dimension, P.P. 235-249
"Social Problems" 15- 1967
10. L.A. Pastalan
Privacy as a Behavioral Concept, P.P. 93-97
"Social Forces" 45(2) - 1975
11. E.T. Hall
The Hidden Dimension
Doubleday, N.Y. 1966
12. R. Sommer
Studies in Personal Space, P.P. 99-110
"Sociometry" 24 - 1961
13. Geoff Shuttleworth
Convertible Space in Office Building
"Building Research" January/March, 1972
14. Philips
Lighting Manuel, P.P. 2.1-2.9
N.V. Philips Gloeilampenfabrieken, 1974
15. Albert H. Dietz
An Approach to the Design of the Luminous Environment, P. 60
M.I.T. Press
16. H.K. Weston
Sight, Light and Work, P.P. 165-166
Lewis & Co. LTD., London 1962

17. John Flynn
Lighting Graphic, P.P. 39-55
Van Nostrand Reinhold Comp., 1962
18. Building Research Station Digest No. 76
Integrated Daylight and Artificial Light in Buildings
1966
19. R.G. Hopkinson
Lighting of the Buildings, P. 69
Praeger Publishers, 1969
20. Naramore, Bain, Brady & Johnson
Window Less Offices, P.P. 28-36
University of Washington, 1970
21. A. Komendant
Architect Louis I. Kahn
Aloray Publisher, 1975
22. D. Krech, R. Crutchfield & E. Ballachey
Individual in Society, P. 21
McGraw-Hill, 1962
23. R. Sommer
Hard Architecture and How to Humanize it
24. Robert Newman
Acoustics, P.P. 20-23
"Time Saver: Standards for Architectural Design Data"
McGraw-Hill, 1974
25. Leslie Doelle
Environmental Acoustics, P. 141
McGraw-Hill, 1972

26. Lila Shoeshkes
Space Planning, P. 104
McGraw-Hill, 1976
27. Leslie Doelle
Environmental Acoustics, P.P. 39-47
McGraw-Hill, 1972
28. Acoustical and Insulating Materials Association
Performance Data: Architectural Acoustical Materials
1973
29. J.R. Rawls
Personal Space as a Predictor of Performance Under Close Working
Conditions
"Journal of Social Psychology" 86(2), 1972
30. R. Newman
Acoustics, P.P. 23-24
"Time-Saver: Standards for Architectural Design Data"
McGraw-Hill Inc., 1974
31. Solutions to Noise Control Problems in the Construction of Houses
Apartments, Motels and Hotels
A.I.A. File #39-E, March 1965

Ackerman, James S.
The Architect and Society: Palladio
Penguin Book, 1966

Aidala, T.
The Great Houses of San Francisco
Alfred A. Knopf

Akademie der Kunste
Erich Mendelsohn
Vol. 14, 1968

Alexander, C.
The Pattern Language
Oxford, 1977

Arthur, Eric & Whitney, Dudley
The Barn
New York Graphic Society

Arwas, Victor
Glass
Rizzoli International Publication, 1977

Bardeschi, Marco
Frank Lloyd Wright
Crown Publishers Inc., 1970

Bell, G., E. Randall, and J.E.R. Roeder
Urban Environments and Human Behavior
Dowden, Hutchinson & Ross, 1973

Bennis & Schein
Leadership and Motivation
(Essays of Douglas McGregor)
M.I.T. Press, 1966

Blake, Peter
The Master Builders
Alfred Knopf, 1961

Blaser, Werner
Osteuropa Strakurale Architektur
Zbinden Druck Und Verlag AG

Bottineau, Yves
Iberian-American Baroque
MacDonald, London 1971

Bruna, A.W. & Utrecht, Zoon
Work of G. Rievelt Architect
The Netherlands, 1958

Bush-Brown, A.
Louie Sullivan
G. Brazieler, Inc., 1960

Canter, David
Office Size: An Example of Psychological Research In Architecture
The Architects Journal, April 1968

Campbell, Helen
Prisons of Poverty: Women Wage Workers, Their Trades and Their Views

Caplow, Theodore
The Society of Work
McGraw Hill, 1954

David, G.
Using Interviews of Present Office Workers in Planning New Offices
W.J. Mitchell (ed.)
Environmental Design: Research and Practice
Los Angeles: University of California/ EDRA 3, 1972

Davidson, Margaret
Successful Studios and Work Center

Delevoy, Robert
Victor Horta
Pour Le Ministere De L Education, Nationale Et De La Culture

Dickson, Paul
The Future of the Workplace: The Coming Revolution in Jobs
Weybright and Tailey, 1976

Dishoeck, Fibula-Van
Nederlands Kunsthistorisch Jaarboek 1974
Bussum 1975

Downs, R. And Stea, D.
Image and Environment
Aldine Publishing Company, 1973

Drucker, Peter
Management: Task, Responsibilities, Practices
Harper & Row, 1973

Drucker, Peter
Hysteria Over the Work Ethic: Beyond Stick and Carrot

Duffy, F.
Role and Status in the Office
A.A. Quarterly 1, 1969

Goffman, Erving
The Presentation of Self in Everyday Life
Overlook Press, 1974

Goldfinger, Myron
Villages in the Sun
Praeger Publisher, 1969

Grue, O.W., P.C. Pran and F. Schulze
100 Years of Architecture in Chicago
Philip O'Hara, 1976

Gullahorn, J.T.
Distance and Friendship as a Factor in the Gross Interaction Matrix
Sociometry 15, 1952

Gyllenhammar, Pehr
People at Work
Addison-Wesley Publication, 1977

Harris, T. George
Psychology of the New York Work Place
New York 10-31, 1977

Hayakawa, Masao
The Garden Art of Japan
Weatherhill, 1973

Hibbard, Howard
Michelangelo
Penguin Books, 1975

Hitchcock, Henry-Russel
In the Nature of Material
Duell, Sloan and Pearce, N.Y., 1942

Hoffer, Eric
Working and Thinking on the Waterfront
Harper & Row, 1969

Humphrier, Lund
An Organic Architecture: Frank L. Wright
Lund Humphrier Publisher Limited, 1970

Hutt, Anthony
North Africa
Scorpion Publications Limited, 1977

Harvard Educational Review: Architecture and Education
Vol. 39, No. 4, 1969

Jenkins, David
Job Power
Penguin Books, 1974

Joedicke, Jurgen
Office Buildings
Frederick Praeger, 1962

Jones, H.G.
Sweden's Modern Manning
Management Today, Sept., 1975

Kleig, Karl
Alvar Aalto
Praeger Publishers

Korda, Michel
Power: How To Get It, How To Use It
Random House, 1975

Lassen, Kenneth
The Workers: Portraits of Nine American Job Holders

Leprohon, Pierre
Florence
Editions Minerua, 1978

Levenstein, Aaron
Why People Work
Crowell-Collier Press, 1962

Lotus 12
The Architecture of the Workplace

Los Angeles County Museum of Art
10 Italian Architects
1967

Mannasseh, L. and R. Cunliffe
Office Buildings
Reinhold Publishing Corp., 1962

Manning, Peter
Office Design: A Study of Environment
Pilkington Research Unit, 1966

Mehrabian, Albert
Public Places and Private Spaces
Basic Books Inc., 1976

Mellor, David
Hertzberger: The Central Beheer Office Complex
Architectural Design 2, 1974

Mill, C. Wright
White Collar, The American Middle Class
Oxford University Press, 1951

Monthly Labor Review
Evaluating Working Conditions in America
Vol. 96, Nov., 1973

Moore, C. and Bloomer, K.
Body, Memory, and Architecture
Yale University Press, 1977

Moore, C. and Allen, G.
Dimensions
Architectural Record Books, N.Y. 1976

Musee d'Ixelles
Antoine Pompe
1969

Nicols, K.W.
Urban Office Buildings: View Variables From Human Response to Tall Buildings
Donald, Conway, Dowden, Hutchinson and Ross

Siren
The Otava Publishing Co., Helsinki, 1977

Pearson, Paul
Alvar Aalto
Watson-Guption Publications, N.Y. 1978

Personal Management
Industrial Democracy: What's on in Europe?
August, 1975

Pfankuch, Peter
Hans Scharoun
Akademie der Kunst, Berlin, 1974

Frank Furness
Philadelphia Museum of Modern Art

Pierson, William
American Builders and Their Architects
Anchor Books/Double Day, 1976

Pile, John
Interior Second Book of Offices
Whitney Publications, Inc., 1969

Pilnadic, R.L.
A Research of Employee Reactions to the Landscape Environment - One Year After Initial Occupation
Eastern Kodak Company, Rochester, N.Y., March 1970

North Russian Architecture
Progress Publisher, Moscow

Quinn, Susan
My Desk is Bigger Than Your Desk: The New Office Status Game

Raskin, A.H.
The Heresy of Worker Participation
Psychology Today 2, 1977

Rettig, R.B.
Guide to Cambridge Architecture
M.I.T. Press, 1969

Roizen, R.
Office Layout and the Behavior of Office Workers
Environmental Analysis Group, 1969

Rudofsky, Bernard
The Prodigious Builders
Harcourt Brace Jovanovich, 1977

Rudofsky, Bernard
Streets for People
Doubleday and Company, Inc., 1964

Ruy, T.
Windowless Offices
Man-Environment System I, 1971

Saphier, M.
Planning the New Office
McGraw Hill, 1978

Schmertz, Mildred
Office Building Design
McGraw Hill, 1975

Scully, V.
Modern Architecture
G. Braziller, 1961

Shoshkes, Lila
Space Planning-Designing the Office Environment
McGraw Hill, 1976

Smith, Ray
Supermannerism
Dutton Paperback, 1977

Sommer, Robert
Design Awareness
Rinehart Press, 1972

Sommer, Robert
Tight Spaces, Hard Architecture and How to Harmonize it
Prentice-Hall Inc., 1974

Steele, F.I.
Physical Settings and Organization Development
Addison-Wesley Publication, 1973

Steen and Vllmark
For the Great Majority of People, Can the Working Day Ever Become an
Alternative Prospect - or Must Hopes of Human Fullfillment - Be Con-
fined to Leisure Time?
Arkitektur, June 1975

Steen and Vllmark
Getting the Feel of the Workplace
Arkitektur, May 1974

Terkel, Studs
Working
Avon Books, 1974

Venturi, R.
Complexity and Contradiction
The Museum of Modern Art - Philadelphia, 1966

Venturi, R.
Learning From Las Vegas
M.I.T. Press, 1977

Vitgevers-Maatschappij
H.P. Berlage
Rotterdam, 1925

Vlack, Don
Art Deco Architecture in New York
Harper & Row, 1974

Vogot-Goknil, Vlya
Ottoman Architecture
Grosset & Dunlap, N.Y., 1966

Walton, Richard
The Quality of Working Life: What is it?
Sloan Management Review: Vol. 15, Fall 1973

Werk
Workplace
Jan., 1976

Whitney, Dudley
The Lighthouse
New York Graphic Society

Whyte, W.H.
The Organization Man
Simon & Schuster, 1972

Wicker, Tom
Swedish Team Work
Architecture DWS, June 1973

Woodbridge, S.
Bay Area Houses
Oxford University Press, 1976

Zeitlin, Lawrence
A Comparison of Employees' Attitudes Toward the Conventional and the
Landscaped Office, Organization and Procedures
Port of New York Authority, April 1969

Zevi, Bruno
Architecture in Nuce
Istituto Per La Collaborazione Culturale, 1960

Zucker, Paul
Town and Square
M.I.T. Press, 1959

SURVEY COMMENTS

TOPICS OF CONVERSATIONS:

1. Number of people interacted with in the daily work environment
2. Number of people in work area
3. Person's attitude toward working conditions:
 1. Physical working space
 - A. Personal space (Immediate surroundings)
 - B. Psychological aspect
4. Should working space be differentiated from other working environments? (i.e., working space of insurance company contrasted with that of a government office, academic environment....)
5. Person's attitudes toward:
 1. Office furniture
 2. Noise, light, temperature (is it properly controlled?)
 3. Open plan landscape office
 4. Traditional cubical office
6. Special places
 1. General equipment or file areas
 2. Eating areas
 3. Rest rooms
 4. Employees lounge
 5. Conference rooms

OBSERVATION:

1. Public space within the work area, is it adequately distributed
2. Light, temperature and noise control
3. Contact within the work area
4. Furniture
5. Position of work area
6. Location of the office (within the hierarchy)
7. Size of the work space (private and public space)
8. Quality of material (such as furniture, chair, desk, carpeting, painting, lighting.....)
9. Accessibility of customers to workers, workers to managers....
10. Basic layout of the plan and workflow
11. Special places
 1. General equipment or file areas
 2. Eating accomodations
 3. Restrooms
 4. Employees lounge

LIGHTING: NATURAL AND ARTIFICIAL

I prefer natural light. And, make sure there are two windows...and an outside view. You don't know what's going on. (without window)

I prefer natural light...don't care for an artificial light.

I like good natural light. I think flourescent light is bad for you.

I like the idea of a skylight here, but it won't work. It's much better than flourescent light.

I don't like flourescent light at all. I'd rather have a desk lamp or natural light.

Not much difference. (natural and artificial light)

I guess I like natural light, but I find it insufficient.

WINDOW:

Everybody likes to have windows - it would be joy. The window here is worthless (window height 10'-0" above the floor level).

You can't see and you can't get fresh air. At one time they would open - now they can't.

To see out is an ideal situation.

Definitely have a site window. (look out)

Do you really want to know, this is terrible. Well, I desire windows very much. Just to look outside to relax my eyes.

Definitely, window. My previous work place had windows and I enjoyed looking out, seeing others. Looking at the wall makes me feel very constricted.

Better than no window (skylight), but I prefer looking out a window.

I love windows. It really makes a difference. Fresh air and looking out is important for me.

Not having any windows doesn't bother me. Not having a door or wall does. (not enough privacy)

I am the only one who doesn't have a window here, and I would like to have one very much.

I like windows I can open.

I think it is nice to have a window.

FURNITURE:

Good

Very generous

I am going to trade for a more comfortable chair to rest my arms on.

I prefer a table with an overhang if I am meeting people. Something I can put my feet under.

I think everybody's body is different. People should be given a choice according their body needs.

All you need is a desk and file cabinet, for me anyway.

LOUNGE:

We have a little lounge. Surprisingly, it's not used much, because it's open between the two sections of the department. (It is on the corridor.) It is rather small. Nothing there to put your feet up on and relax. That type of thing. They find it not that inviting.

There is a group of us who use the lounge. Everybody goes for coffee. But actually, five to six people use it constantly (six workers). Some of the husbands come to visit and use that space because it is close. Given the choice, I will go someplace else.

I would rather sit in here (office) than go to the lounge.

I usually eat lunch in the lounge. I go for breaks and coffee. It's O.K.

Usually people go out and buy their food. We do have a kitchen but nobody really uses it. It's only used for meetings...sometimes pot lucks.

It would be nice to have a lounge where you can interact with other parts of the department.

Our lounge is used for conferences and meetings. It was one of the first things we wanted. But we discovered we didn't have any space for it. I think it would have been very nice to have, but it wasn't given top priority. (office manager)

COLOR:

They tried to introduce colors. The panels were blue...Myself, I enjoy my work. We don't have wall space. My own personal feeling is that very little color is required.

The color is really ugly. Mismatched all over. (orange, blue, green)

The color scheme in this office is terrible - it clashes. The most acceptable color scheme in an office is a light color, easy color, not a dark shade.

This is an attempt to make something but it is ugly. They should allow people to paint what they want in their office. I should be allowed to paint as I want. I have to spend the most hours in here.

Definitely the color is mismatched. I worked in a place where the pillars were orange and it drove everyone crazy. No orange pillars. It was an ugly orange, not bright.

I like mute colors and subdued.

As long as it's comfortable and doesn't clash.

I love this color...it's very soft. (ivory white)

I don't like this color, personal reason.

NOISE LEVEL:

The noise is very high, no privacy.

I find it very difficult to interview in terms of being confidential... any kind of private conversation or telephone calls.

I cannot speak in a normal tone.

It's workable.

The noise level is very high.

To some degree it helps, but not much. (fan)

It is workable.

It is very noisy here. The noise carries and I can hear everyone.

I find it very noisy here.

I try to carry a conversation as quiet as possible in this place. But some people totally disregard it. But when we make noise (secretaries), we are certainly scrutinized.

There's a lot of street noise. The building is not properly sealed. We have acoustical ceiling and no masking noise.

EATING AREA:

The cafeteria is terrible. The flow of people is very bad. Standing line is bad and slow. I don't know but there is something wrong. I don't care for that wait, and usually don't take a lunch break. Lunch hour should be a relaxing thing. I don't know about the space but the design is all wrong.

Actually, they had food caterers there. There were windows all along. It was just one big open place, but a lot of windows. It was popular. (previous work place)

The cafeteria is fun. Food and price is not that bad.

Cafeteria is terrible. I used it only a couple of times. One thing, the food is terrible. Hamburger is greasy and overpriced.

Plants and a view need to be in the cafeteria. The one space I know is very clean, food is excellent. It is clean and neat. Space was a big room. (agency she just left) All the executives occupied the window sitting area.

I usually bring lunch and sit at my desk.

The cafeteria is a convenience. But I am not very pleased with it.

Usually, I go out and buy a sandwich and come back to my office.

GENERAL COMMENTS BY WORKERS:

I don't like great big rooms. If necessary, there should be only several people in the area. Keep it small. Everybody should have privacy. It's not necessary to have a door, but some kind of privacy is needed. I think that productivity goes down, because you have to listen to the noise and distractions. I find work in the open plan distasteful. Telephone is distracting. It should be possible for everyone to have some kind of place that makes you feel a part of the area.

There is no privacy. There is an illusion of privacy by this partition. (open plan office)

I like the idea of partitions. But if they can make it more noise proof, for confidential reasons, it would be better.

What's important is that there is little privacy. Every conversation is listened to. I get tired of it - working in the large office.

For my particular job, I need privacy, because of consultations with customers.

This place is poorly designed. First of all, it's very cold in the winter and the air conditioning is not cool enough during the summer. A lot of the problem is the partition...not connected to the wall...very dangerous. You don't have a doorway in this office.

There is no privacy. You can't close a door.

I feel closed in and boxed in with this partition.

Conference room should be away from the public area.

I think open plan office is useless. It is pretty, but they are only decorative.

Avoid the long corridor.

I don't like privacy. I do and I don't. It seems everyone is separated in this office. Usually constricting conversations between workers. It tends to isolate you, and I don't like it.

I don't like this wall. (open plan partition)

I would like to see these walls tumble down. (open plan partition)

I wouldn't like all the desks in a row sitting together.

You don't have to listen to other people and still hear them. It would be nice to have some sort of separation.

I wasn't interested. If they made up their mind, I know they would do it anyway. (shaping the work environment)

I think my only comment would be that people have to realize that a secretary or clerk also needs privacy to do work well. We should have enough recognition to have privacy. It is always violated in the large working place. There is no privacy what-so-ever in here.

I love it here. I was in charge of who was going to have which space and I chose this space. Sitting in this room with both windows.
(manager)

There is no privacy. Everyone who passes by can look in. Not having privacy bothers me.

I guess I like the privacy of my room and partial open space. I would find it hard to work in the landscape office. I think it is cheaper to do open plan offices.

This is not anchored (open plan partition) and is very unsafe. Sort of dangerous.