

Document Room, **DOCUMENT ROOM 36-412**  
Research Laboratory of Electronics  
Massachusetts Institute of Technology

*copy #1*

# Q MEASUREMENTS FOR HIGH-Q CAVITIES

R. A. RAPUANO and J. HALPERN

*LOAN COPY*

TECHNICAL REPORT NO. 7

JUNE 28, 1946

*my*

RESEARCH LABORATORY OF ELECTRONICS  
MASSACHUSETTS INSTITUTE OF TECHNOLOGY

The research reported in this document was made possible through support extended the Massachusetts Institute of Technology, Research Laboratory of Electronics, jointly by the Army Signal Corps, the Navy Department (Office of Naval Research), and the Army Air Forces (Air Materiel Command), under the Signal Corps Contract No. W-36-039 sc-32037.

MASSACHUSETTS INSTITUTE OF TECHNOLOGY

Research Laboratory of Electronics

Technical Report No. 7

June 28, 1946

Q MEASUREMENTS FOR HIGH-Q CAVITIES

by

R. A. Rapuano and J. Halpern

Abstract

A method of determining the parameters of a high-Q cavity in bandwidth measurements at microwave frequencies is outlined. A highly stabilized oscillator is used as the reference frequency and one of the sidebands generated in a modulator is used as the variable frequency. Measurements taken with such a system show that Q's of the order of  $10^5$  are easily determined.



## Q MEASUREMENTS FOR HIGH-Q CAVITIES

Microwave techniques applied to physics and engineering have often made desirable the measurement of resonant cavity parameters to a high order of accuracy. Among the most important of these parameters are the quality factor  $Q$ , the input impedance at resonance  $R_s$ , and the resonant frequency  $f_0$ . These quantities can be determined by measuring the input impedance as a function of frequency; that is, the standing-wave ratio and position of the minimum at different frequencies. Hitherto, this method has been limited to fairly low- $Q$  cavities in the range up to about  $10^3$  by oscillator stability and frequency setting requirements, but recent developments in the field of stabilized oscillators<sup>1</sup> have made possible the extension of the technique to the accurate measurement of  $Q$ 's up to  $10^5$  and higher.

### 1. Theory<sup>2</sup>

Consider a parallel resonant circuit fed by a generator of impedance normalized to unity (Fig. 1).

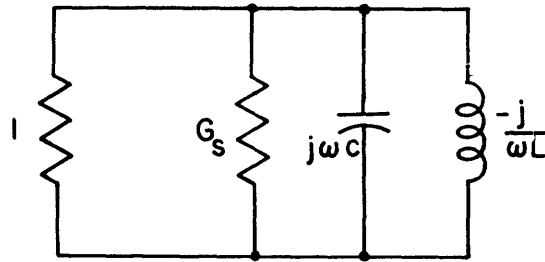

Figure 1

Then the input admittance is:

$$Y = G_s + j(\omega C - 1/\omega L) . \quad (1)$$

Substituting

$$\omega_0^2 LC = 1 , \quad (2)$$

$$Q_L = 1/(G_s + 1)\omega L , \quad (3)$$

and the approximation  $\omega + \omega_0 = 2\omega_0$ , we obtain

1. R. V. Pound, "Electronic Frequency Stabilization of Microwave Oscillators", RSI, 17, 490 (1946).  
R. V. Pound, "An Electronic Frequency Stabilization System for CW Microwave Oscillators", RL Report 815 (1945).
2. C. W. Jones, "Measurements of Resonant Cavities", RL Report 53-9/30/43.

$$Y = G_s + 2j(G_s + 1)Q_L(f - f_0)/f_0 . \quad (4)$$

$Q_L$  is the loaded Q; that is, the Q of the resonant circuit loaded by the generator impedance. The unloaded Q is the Q of the resonant circuit when the coupling to the generator is arbitrarily small, and is given by

$$Q_o = Q_L(1 + 1/G_s) . \quad (5)$$

Since the absolute value of the reflection coefficient  $|\alpha|$  is related to the terminal admittance of a line by

$$|\alpha|^2 = \frac{(1 - G)^2 + B^2}{(1 + G)^2 + B^2} , \quad (6)$$

we may substitute the admittance of the resonant circuit to obtain

$$|\alpha|^2 = 1 - \frac{4G_s}{(G_s + 1)^2} \cdot \frac{f_0^2}{4Q_L^2(f - f_0)^2 + f_0^2} . \quad (7)$$

If the fractional bandwidth is defined as

$$n = 2Q_L \frac{(f - f_0)}{f_0} , \quad (8)$$

the equation takes the simple form

$$|\alpha|^2 = 1 - \frac{4G_s}{(G_s + 1)^2} \cdot \frac{1}{n^2 + 1} . \quad (9)$$

This equation is plotted for various values of  $G_s$  or  $1/G_s$  (see Fig. 2), depending on whether the resonator is over- or under-coupled. The values of  $|\alpha|$  and  $r$  at the half-power points can be obtained from the formulas

$$|\alpha_1|^2 = \frac{1 + |\alpha_o|^2}{2} \quad (10a)$$

$$r_1 = \frac{r_o + 1 + \sqrt{r_o^2 + 1}}{r_o + 1 - \sqrt{r_o^2 + 1}} \quad (10b)$$

where  $\alpha_o$  is the reflection coefficient at resonance ,

$\alpha_1$  is the reflection coefficient at the half-power points ,

and  $r = \frac{1 + |\alpha|}{1 - |\alpha|}$  is the voltage standing-wave ratio.

The bandwidth, determined from the frequency difference ( $f_1 - f_2$ ) at the half-power points, gives the loaded Q from the relation

$$Q_L = \frac{f_0}{f_1 - f_2} , \quad (11)$$

while the unloaded Q is obtained from the equation

$$Q_o = Q_L(1 + r_o) \quad \text{when } G_s < 1 \quad (12a)$$

or

$$Q_o = Q_L(1 + 1/r_o) \quad \text{when } G_s > 1. \quad (12b)$$

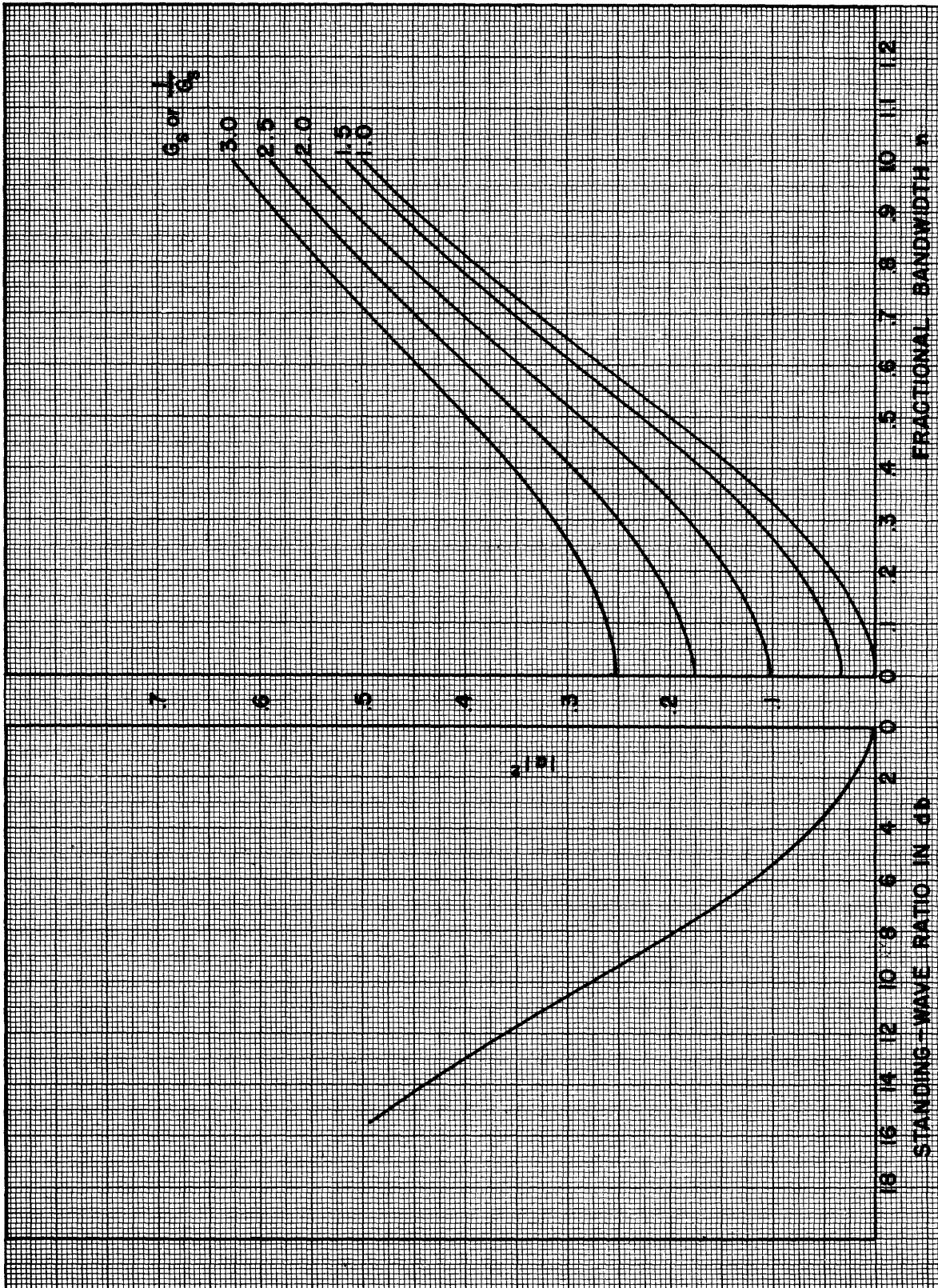

Figure 2a. Relation between standing-wave ratio in db and the absolute value of the reflection coefficient squared.

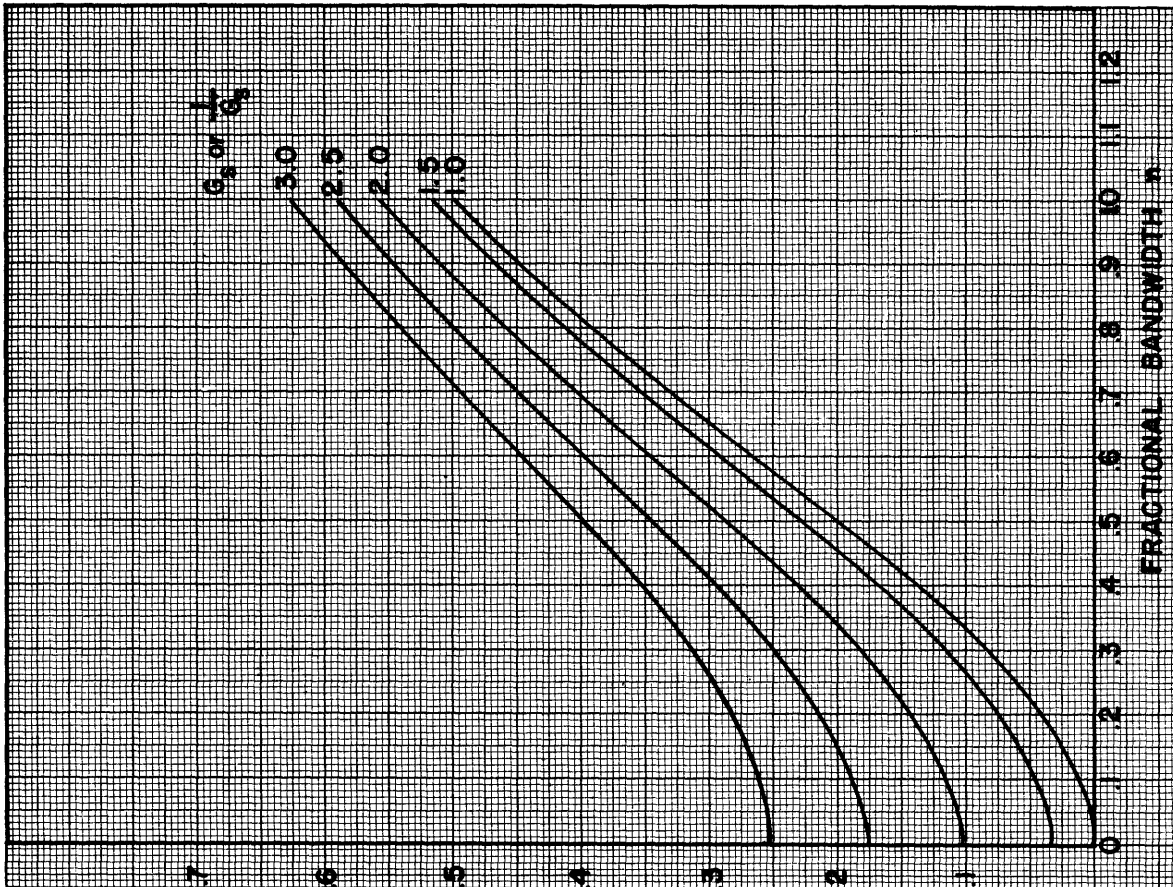

Figure 2b. Plot of Equation (9) for several values of  $G_s$ .

## 2. Apparatus

The Stabilized Oscillator. There are several methods of obtaining the requisite stability of the r-f oscillator, which should have short time drift of the order of one per cent of the bandwidth to be measured; for this work we have used the d-c stabilized oscillator described in RL Report 815<sup>1</sup>. The heart of this equipment is the "magic T"<sup>3</sup>. This is an eight-terminal network (Fig. 3) in

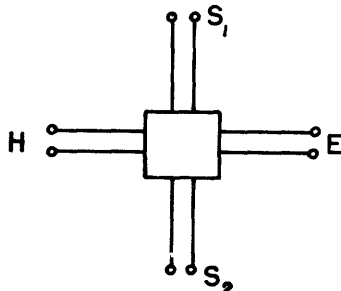

Figure 3. Magic T represented as eight-terminal network.

waveguide or coax having symmetry properties analogous to those of a "hybrid coil". In the case of an ideal T, power entering the E arm is divided equally between  $S_1$  and  $S_2$ , both parts being out of phase; none goes directly to H. Power entering the H arm is divided equally between  $S_1$  and  $S_2$ , with both parts now in phase; no power goes directly to E. Power reflected from the loads on  $S_1$  and  $S_2$ , however, can be coupled from H to E, depending upon the magnitude and phase of the terminal impedances on  $S_1$  and  $S_2$ . In the case of two short circuits the power going from H to E can be caused to vary from zero to the full amount depending on their position along the line. If a short circuit is placed on  $S_1$  and a resonant cavity is placed on  $S_2$ , then the power going from H to E is a function of frequency. The power reflected back from H is the difference between the input and the loss due to transmission through E and absorption in the resonator. The power transmitted is fed into a crystal and the power reflected is picked up with a directional coupler and fed into another crystal; the outputs of these crystals are fed into a push-pull d-c amplifier. Far off resonance the reflected power equals the input power, hence the d-c amplifier is balanced. This same situation obtains at resonance. On the skirts of the selectivity curve, however, the impedance of the resonator is complex. This introduces a phase shift which upsets the equality of the rectified signal output of the crystals, unbalances the amplifier, and thus gives an error voltage.

The magic T's are fed by the velocity-modulated tube to be stabilized, and the error voltage obtained as described above is fed back to the repeller of this tube. The oscillator thereby maintains a frequency stabilized at the reference cavity frequency. Thus the circuit is in effect an AFC circuit using a microwave

3. R. L. Kyhl, "The Use of the Magic T Microwave Bridge in Measuring Impedance", RL Report 643 (1944).

discriminator<sup>4</sup>. A block diagram of the whole equipment is given in Fig. 4 and a photograph of the stabilized oscillator is shown in Fig. 5.

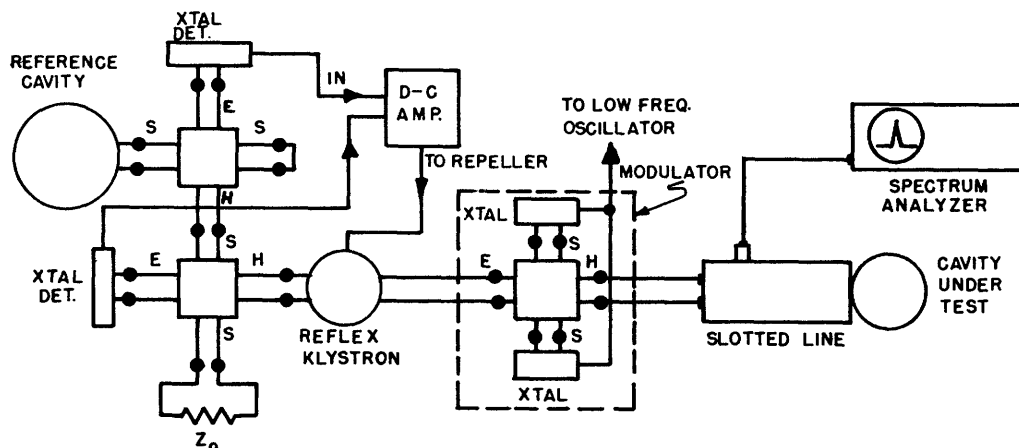

Figure 4. Block diagram of arrangement for high-Q measurements.

Method of Frequency Measurement. Ordinary methods of frequency measurement are quite inadequate for the small frequency differences involved in high-Q cavities. But by modulating the output of the oscillator with a frequency of the order of the bandwidth to be measured, in this case by means of a balanced modulator consisting of rectifying crystals in the S arms of a magic T, sidebands are generated; the sideband frequencies differ from the carrier frequency by multiples of the modulating frequency. Variation of the sideband frequencies (by changing the modulating frequency) allows small frequency differences to be measured with an accuracy limited only by the calibration of the oscillator used for modulation. If the crystals used at the ends of the S arms are tuned correctly, the efficiency of modulation can be increased quite appreciably.

The Detector. A spectrum analyzer (see Fig. 6) has been found most convenient for use as a detector inasmuch as it requires no critical tuning; nevertheless, it allows measurements to be taken using any one of the frequencies leaving the modulator. The calibrated attenuator in the input allows accurate determination of the relative amplitude of any signal.

The Slotted Section. When measuring impedances, a well constructed slotted section and probe (see Fig. 7) is required for accurate work. The inherent error due to mechanical faults should be low or else it should be measured independently and applied as a correction to other impedance data.

4. R. V. Pound, "A Microwave Frequency Discriminator", RL Report 662 (1945).

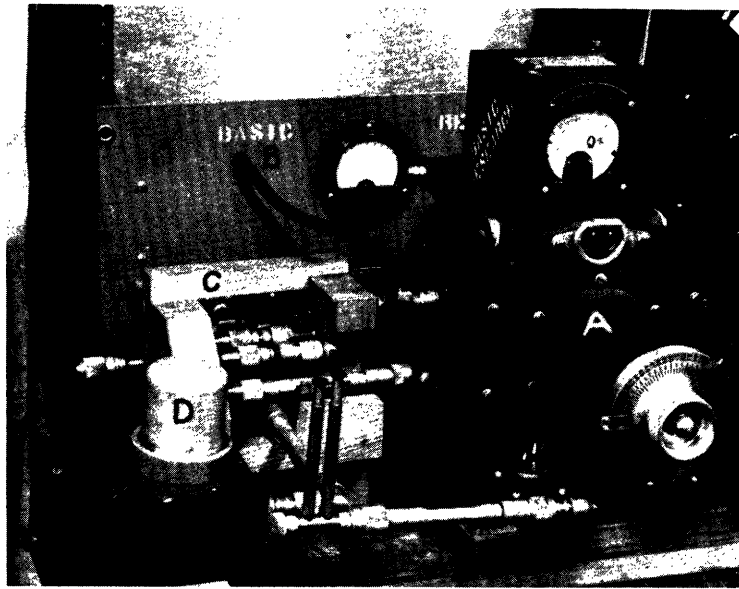

Figure 5. Stabilized oscillator. (A) echo box, (B) d-c amplifier, (C) Magic T discriminator, (D) 726C tube in shield.

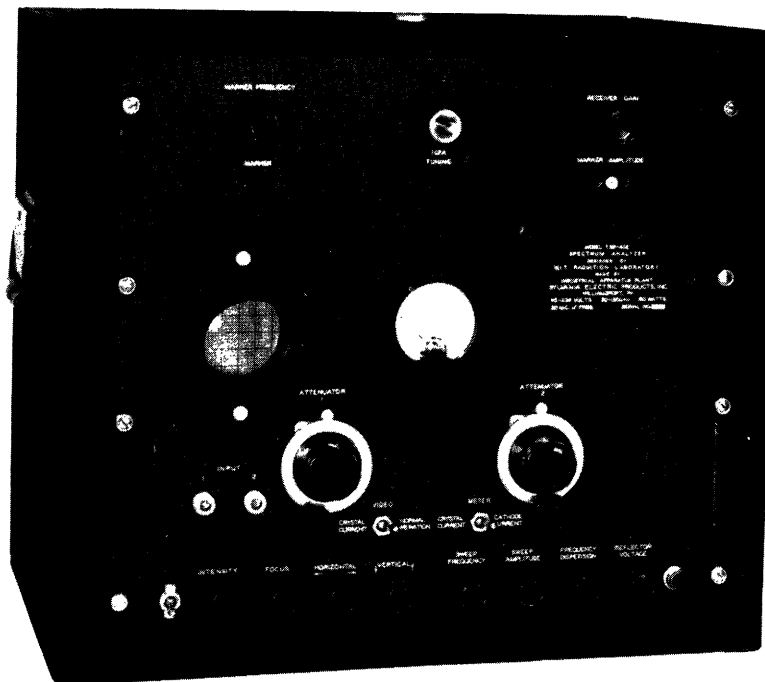

Figure 6. Spectrum analyzer.

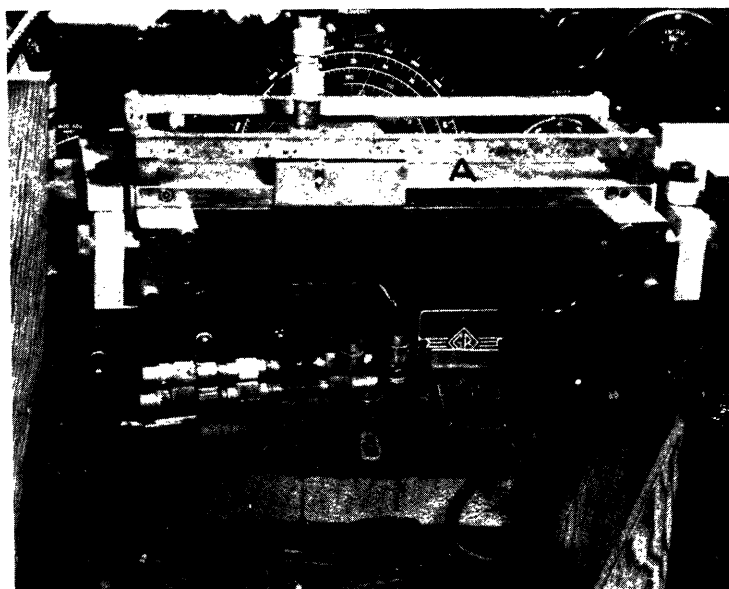

Figure 7. (A) Slotted section,  
(B) balanced modulator.

### 3. Procedure

In order to determine the frequency region of the measurements, the resonant frequency of the cavity under test must first be found approximately. This can be done by ordinary standard methods applying the fact that the resonant frequency is the one at which transmission through the cavity is a maximum or the standing-wave ratio is a minimum. Then the carrier is stabilized at a frequency a little off to one side of the resonant frequency of the cavity under test. In this fashion, the entire resonance curve of the cavity is caused to lie within the range of variation of one of the first-order sidebands. With this sideband as the variable frequency, the readings then consist of noting the frequency and the corresponding voltage standing-wave ratio and position of the minimum in the slotted section. From a plot of the VSWR vs. the modulating frequency, the minimum VSWR  $r_0$  is determined. By substituting  $r_0$  in Eq. (10b), the value of the VSWR at the half-power points,  $r_1$ , is obtained; and hence, from the plot again, the frequency difference between these points. The absolute resonant frequency  $f_0$  is read with sufficient accuracy from an ordinary wavemeter.

Application of Eq. (11) then yields the loaded  $Q$ . The unloaded  $Q$  is obtained from Eq. (12a) or (12b), depending upon whether the cavity is over- or undercoupled. The degree of coupling is determined by the behavior of the minimum of the standing wave. This is illustrated by the curves of Fig. 8.

Where somewhat less accuracy is acceptable, measurements can be made of the standing-wave ratio and frequency at two points, one at resonance and the other at some arbitrary point on the resonant curve of the cavity. Then,  $G_s$  being

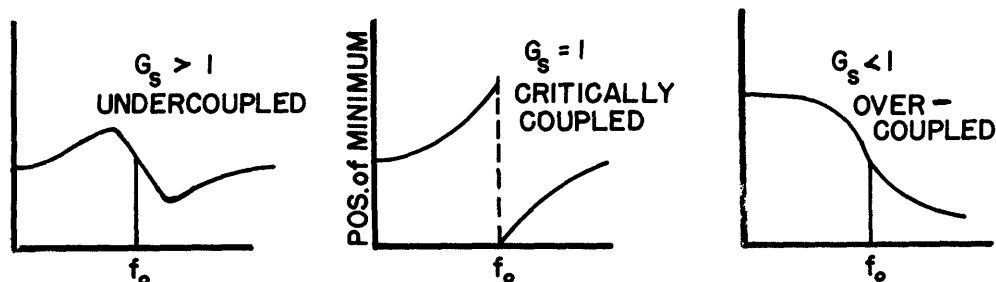

Figure 8. Dependence of the position of the minimum on frequency and coupling.

determined from the VSWR at resonance, the second standing-wave ratio reading gives the fractional bandwidth  $n$  (see Fig. 2 or Eq. (9)). Finally,  $Q_L$  is obtained from Eq. (8).

#### 4. Application

A specific application of the principles outlined above is involved in an arrangement used in this laboratory. A 726C reflex klystron operating at 2800 Mc provides the stabilized frequency, while the receiver is a TSS-4SE spectrum analyzer. Measurements of relative signal amplitude accurate to 0.1 db or better are given by the calibrated attenuators in the input.

The modulation frequency is obtained from a General Radio Oscillator covering the region, 16 kc to 50 Mc, the choice in range depending upon the  $Q$  to be measured. Sideband amplitudes are obtained which are only 7 db below the carrier amplitude measured without the modulator in the circuit.

The stabilizer consists of a standard Pound d-c amplifier, an echo box having a loaded  $Q$  of about 25,000 as the reference cavity for the microwave discriminator, and coaxial line magic T's. This apparatus gives a short time stability of better than 5 kc during the course of a run. While long time drift is much greater, it is usually insignificant for the times involved in most measurements. The relative resonant frequency of a cavity which is nearly critically coupled can be determined to better than 10 kc in a single measurement; this makes it possible to measure quite accurately small changes in resonant frequency. By this method  $Q$ 's in the range 1000 to 25000 can be measured with an accuracy of 5% or better, without special precautions.

Figure 9 gives measured points obtained with a cavity of unloaded  $Q$  in the neighborhood of 16,000. The solid curve represents the theoretically computed shape of the resonance.

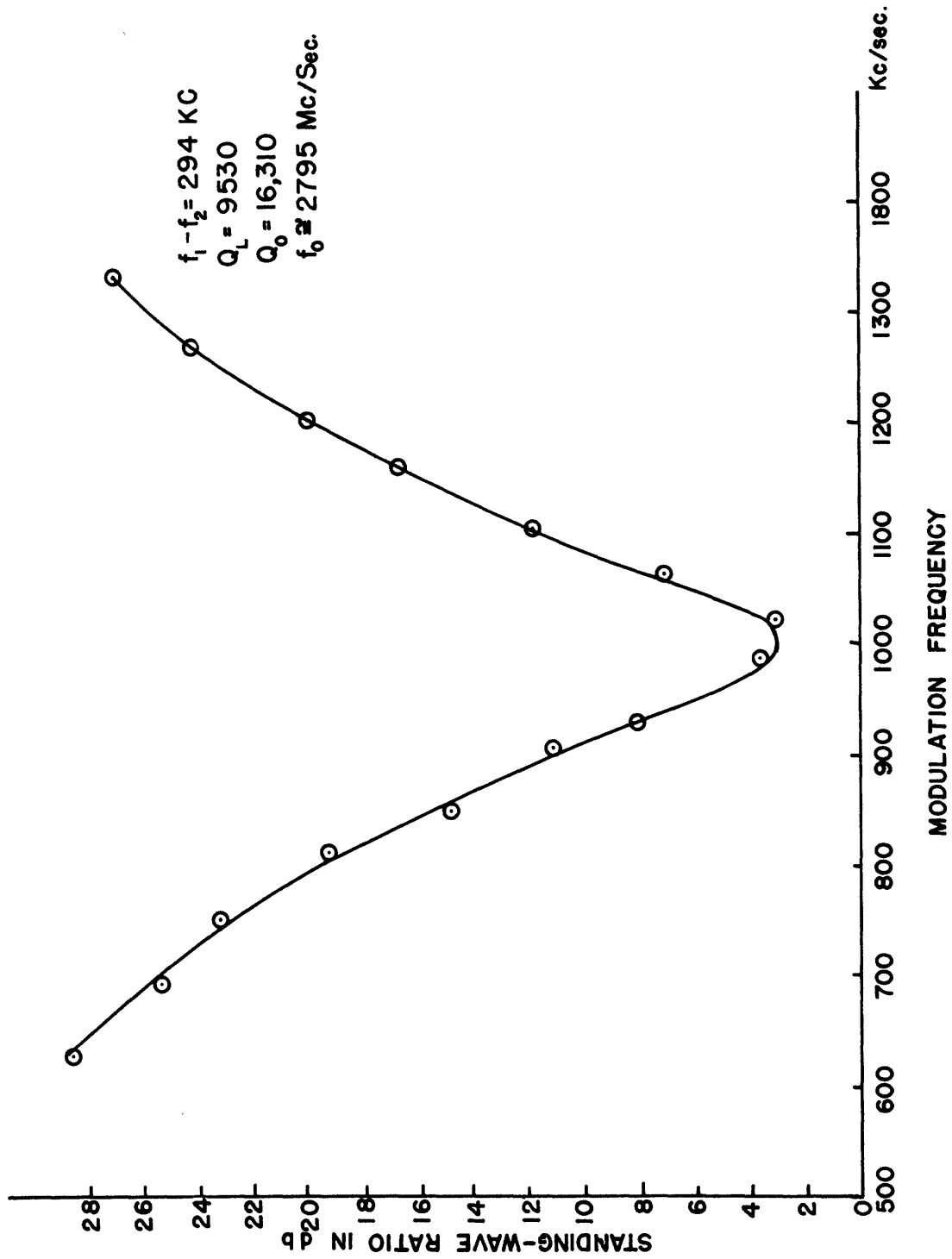

Figure 9. The solid curve is the resonance curve calculated from Eq. (7) with the experimental data given in the legend. The indicated points are experimentally determined.

