

## X. PROCESSING AND TRANSMISSION OF INFORMATION\*

Prof. P. Elias	R. R. Capraro	M. H. Myers
Prof. R. M. Fano	E. Ferretti	L. S. Onyshkevych
Prof. D. A. Huffman	J. V. Harrington	E. T. Schoen
Prof. C. E. Shannon	Cynthia H. Hsaio	S. H. Unger
Dr. M. V. Cerrillo	R. S. Marcus	J. M. Wozencraft
Dr. M. P. Schützenberger		W. A. Youngblood

### A. IMPROVEMENT OF RISE-TIME CHARACTERISTICS OF DEGRADED WAVEFORMS

Improvement in the rise-time characteristics of a system whose bandwidth is essentially limited has been attained by the use of some nonlinear properties of 6AS6 gating tubes. The improvement was of the order of 7 to 10 in rise time, with the rise time defined as the time required for the signal to rise from 10 per cent to 90 per cent of its final value. This rise-time improvement is made at the expense of pulsewidth if the input is essentially a square pulse.

The circuit that was developed has applications in television, where narrow-bandwidth transmission results in slow rise times. Although the system has not been fully tested, some preliminary photographs indicate a good deal of crispening of waveforms. When the waveforms are viewed on a television screen, the effect of increasing the slope of leading and trailing edges has resulted in much sharper pictures. This work is fully reported and illustrated in a thesis by Michael H. Myers, "Improvement of Rise-Time Characteristics of Degraded Waveforms," submitted to the Department of Electrical Engineering, M.I.T., in partial fulfillment of the requirements for the degree of Bachelor of Science, May 1957.

M. H. Myers

### B. INFORMATION-LOSSLESS CIRCUITS

We are making a study the purpose of which is to determine a single logical block diagram that can be used to specify the entire class of information-lossless, single-channel, binary sequence filters. Three diagrams have been found, each of which represents a particular subclass of the more general class of circuits which we wish to determine.

By an information-lossless filter we mean a circuit whose (unseen) input sequence of digits can always be determined by (a) observing its corresponding output sequence, (b) knowing the final state of the circuit at the end of the sequence, (c) knowing the state of the circuit at the beginning of the sequence, and (d) having a knowledge of the logical

---

\*This research was supported in part by Purchase Order DDL-B187 with Lincoln Laboratory, which is supported by the Department of the Army, the Department of the Navy, and the Department of the Air Force under Contract AF 19(122)-458 with M.I.T.

(X. PROCESSING AND TRANSMISSION OF INFORMATION)

design of the circuit. (These conditions are sufficient but are not always necessary for specifying an information-lossless circuit.) In other words, the circuits in which we are interested are those for which no two different input sequences of equal length that start from a common initial circuit state and result in a common final circuit state ever cause the same output sequence.

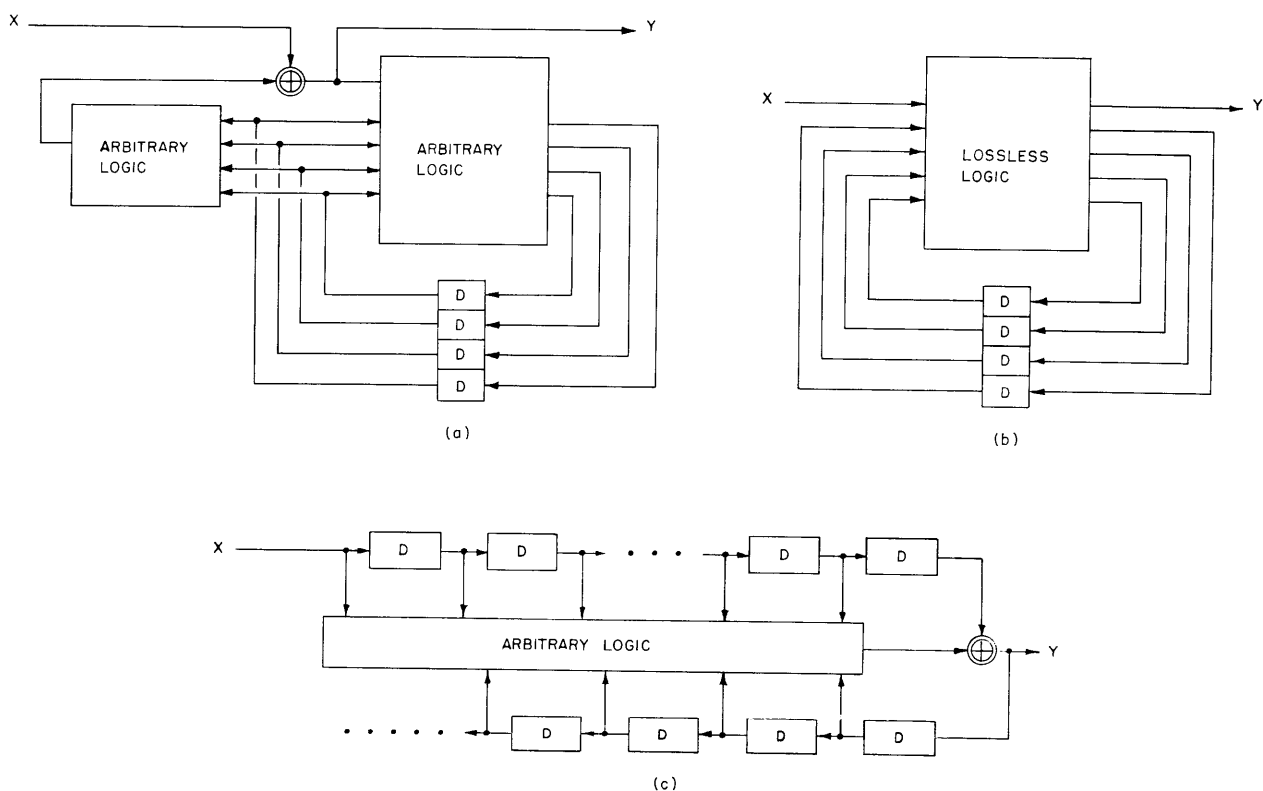

Fig. X-1. Block diagrams of three information-lossless binary filters.

If we are given a state diagram that specifies an arbitrary digital filter, it is a straightforward task to determine whether or not the circuit itself is lossless in the sense described above. However, at the present time, it is much more difficult to determine from the circuit diagram itself whether or not it is lossless. This difficulty furnishes the motivation for this research. One fact that acts as a spur to our efforts is that the circuit complexity is roughly linearly related to its number of memory elements, while the associated state diagram has a complexity exponentially related to the number of memory elements. Thus, even for comparatively simple circuits, the state diagram may be impractical to draw, and therefore tests cannot be made on it. We are forced to examine the circuit itself.

## (X. PROCESSING AND TRANSMISSION OF INFORMATION)

Three special subclasses of the general lossless circuit are shown in Fig. X-1a, b, and c. The symbols used include unit delays (realizable with shift registers in a synchronous circuit), two-input, modulo-two adders (the small circles), and logical (memoryless), multi-input circuits that are either completely arbitrary, or ( see Fig. X-1b) are themselves lossless in the sense that there is a one-to-one correspondence between their input and output combinations.

Figure X-1a gives a general representation of circuits that have constructable inverses which, given the  $y$ -sequence, can reproduce the  $x$ -sequence with no delay. The circuits represented in Fig. X-1b have the property that the initial state of the circuit (see item (c), above) need not be known in order to determine the  $x$ -sequence from the  $y$ -sequence. Another type of lossless circuit is shown in Fig. X-1c.

D. A. Huffman