

X. RADIO ASTRONOMY*

Prof. A. H. Barrett	V. J. Bates	J. W. Kuiper
Prof. J. W. Graham	J. C. Blinn III	B. R. Kusse
Prof. R. P. Rafuse	J. A. Bosco	D. H. Staelin
Dr. G. Fiocco	P. J. Brendel	D. H. Steinbrecher
R. J. Allen	R. K. Breon	S. Weinreb
A. T. Anderson III	J. R. Cummings	C. D. Wende
	G. A. Garosi	

RESEARCH OBJECTIVES AND SUMMARY

The research areas of this group may be subdivided as follows:

1. The detection and measurement of the radio radiation from extraterrestrial sources, principally at short centimeter and millimeter wavelengths.
2. The application of microwave radiometric techniques to the study of the physical structure of planetary atmospheres, especially the earth's atmosphere.
3. The use of a laser to probe the earth's atmosphere by means of an optical radar, utilizing back scatter from aerosols and molecules.
4. A study of very wide base-line interferometry for radio astronomical measurements.

This program of research requires the development of new techniques in several areas of radiometry. For example, the study of pressure-broadened molecular resonances such as occur in planetary atmospheres dictates the development of a radiometer operating at millimeter wavelengths and having the capability of providing information about line shapes over a frequency interval of several thousands of megacycles. Another example is a result of the need to perform experiments from high-altitude aircraft, balloon-borne platforms, satellites, and space probes, which imposes stringent requirements on equipment design. For purposes of wide base-line interferometry, methods are to be sought by which phase synchronism of local oscillators may be realized and techniques of signal processing and transmission may be utilized to give accurate reproduction of the interference pattern.

In all areas of endeavor listed here, experimental and/or theoretical research and development is under way. During the past year, work has been concentrated in items (1) and (2); items (3) and (4) have recently been initiated. Theoretical studies of the terrestrial H_2O line at $\lambda = 1.35$ cm, and of the microwave spectrum of Venus have been completed. Radiometers operating at K-band, V-band, and E-band have been designed and partially constructed, and preliminary measurements at K-band have been carried out. A 10-ft precision parabolic antenna has been installed on the roof of the Laboratory and is being fitted with a digital control system to allow accurate pointing in celestial coordinates. This facility will be used for lunar and solar research at millimeter wavelengths.

A. H. Barrett, J. W. Graham

A. K-BAND RADIOMETRY

A microwave radiometer operating at 25.5 kmc ($\lambda=1.25$ cm) has been constructed and installed in Lincoln Laboratory's 28-ft precision parabolic antenna. The purpose

* This work is supported in part by the National Aeronautics and Space Administration (Contract NaSr-101, Grant NsG-250-62, Grant NsG-264-62); and in part by the U.S. Navy (Office of Naval Research) under Contract Nonr- 3963(02)-Task 2.

(X. RADIO ASTRONOMY)

of this experiment is twofold:

(i) to provide operational tests of a complete radiometer before it is incorporated into a multichannel system; and

(ii) to observe Venus during the 1962 inferior conjunction.

The frequency was chosen to be compatible with the present antenna feed horn, and to be as near as possible to one of the frequencies of the radiometers aboard the Mariner R-2 Venus spacecraft. Furthermore, by means of a frequency diplexer, measurements are planned simultaneously at 35 kmc ($\lambda=0.8$ mm) with a common antenna feed used. The 35-kmc radiometer has been constructed by Lincoln Laboratory personnel. The K-band ground-based measurements are of value because there are no existing measurements of Venusian radiation at this wavelength.

A block diagram of the radiometer is shown in Fig. X-1. The system is a conventional Dicke superheterodyne radiometer employing noise balancing in the antenna input arm. The ferrite switch operates at 94 cps and the bandwidth of the system is 8 mc, as determined by the 30 mc if amplifier. Preliminary tests of the equipment installed on the antenna give an rms temperature fluctuation of approximately 1.2°K with a 5-second integration time.

A multichannel version of this receiver is being built which will incorporate several channel-dropping filters, similar to the diplexer used for frequency separation in

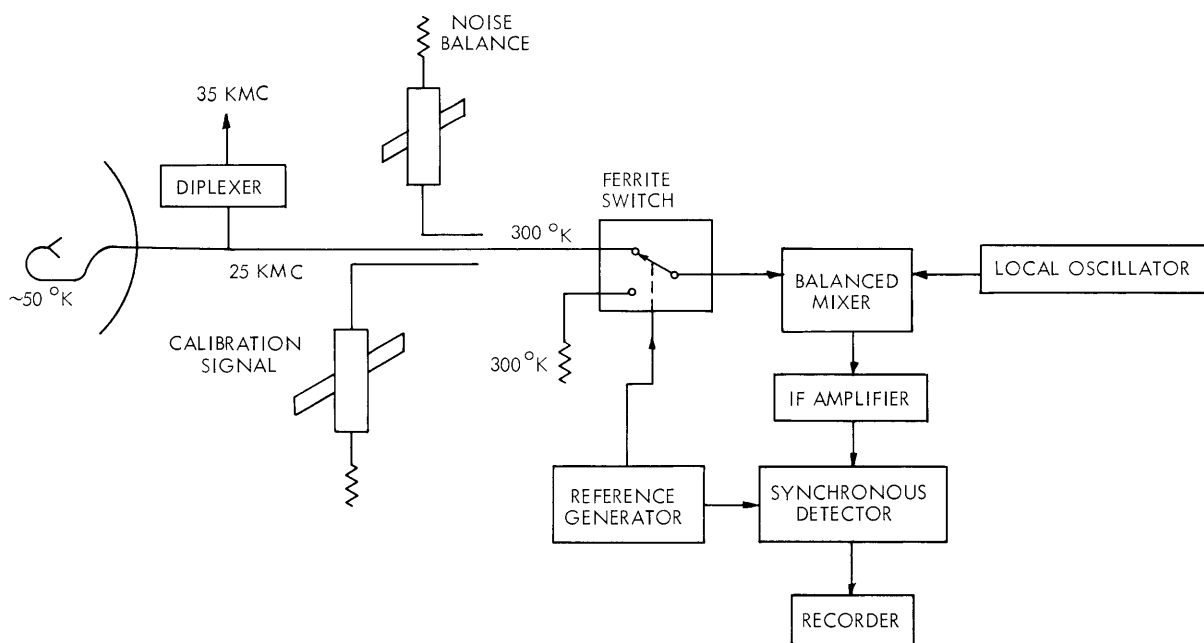

Fig. X-1. K-band radiometer.

Fig. X-1. It is planned to cover the frequency range 18-35 kmc with this arrangement. In addition, a digital synchronous detector for improved long-term stability has been designed and is being tested. The data output will be fed to a tape punch to allow automatic data processing. The completed system will be used for detailed studies of planetary atmospheres.

D. H. Staelin

B. SOLID-STATE LOCAL OSCILLATORS

Two solid-state local oscillators are under development. One will be built to produce 1 mw at 60,152 mc, and the other will produce 2 mw at several frequencies near 22,000 mc (for water-vapor line studies). At present, work is just beginning on the design and synthesis of both chains, and only preliminary design data are available.

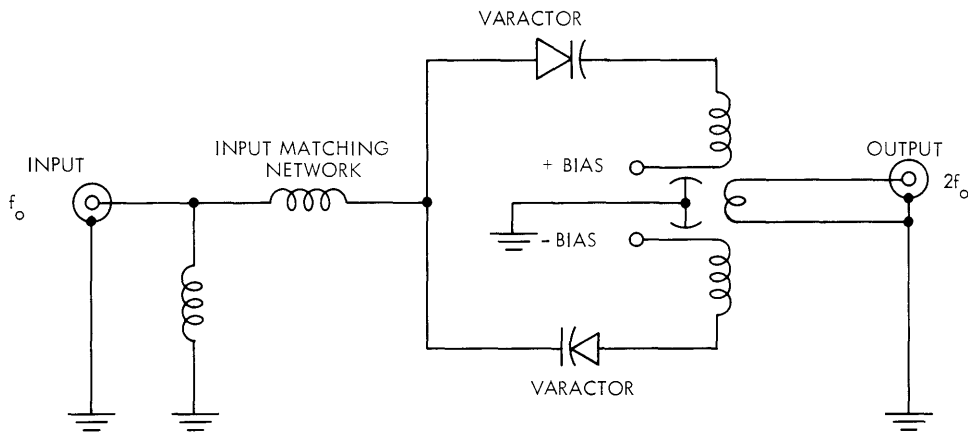

Fig. X-2. Improved doubler circuit.

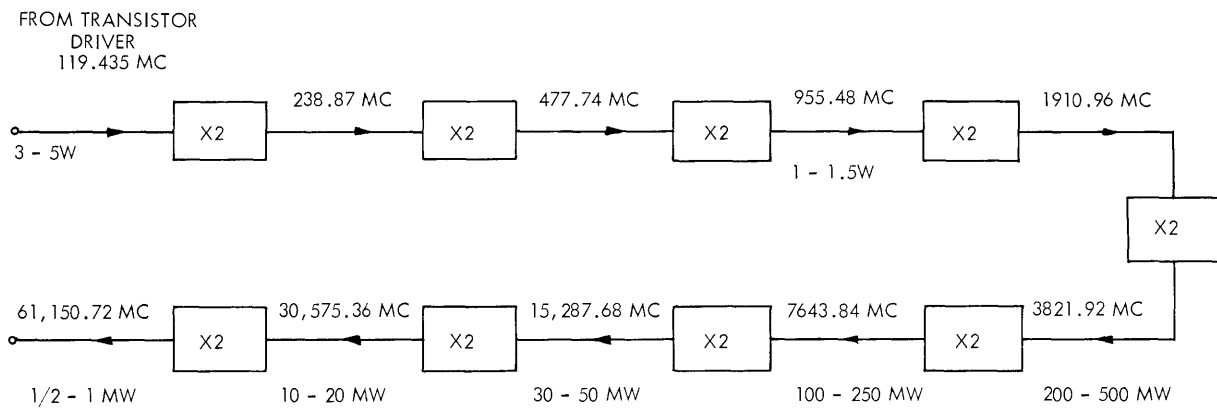

Fig. X-3. 60-Gc chain with expected power levels.

(X. RADIO ASTRONOMY)

The chain for 60 Gc will be composed of nine doublers starting from 119.435 mc. Designs have been firmed for the first four stages and the last stage. A typical circuit for one of the first four stages is shown in Fig. X-2. This particular circuit is a definite improvement over previous two-diode balanced circuits because it allows the output inductance to be four times larger, and thus facilitates the use of "lumped" circuits at frequencies in excess of 1 Gc. The over-all block diagram is shown in Fig. X-3.

At present, the K-band chain is planned as a string of four doublers to 2200 mc with an output power of 500 mw nominal, followed by a times-ten stage direct to 22 Gc with 2 mw expected output. Considerable attention will have to be paid to spurious signals, and heavy filtering will probably be necessary.

R. P. Rafuse

C. A RELATIONSHIP BETWEEN CURRENT DENSITY \bar{J} AND FAR-ZONE RADIATION FIELDS

An examination of the relation between the source-current distribution and the far-zone electromagnetic field radiated by the current distribution has been made. It has been demonstrated that the curl of the current distribution uniquely determines the far-zone fields. Specifically, it has been shown that $\nabla \times \bar{J}$, where \bar{J} is the current distribution, and the far-zone magnetic field is a three-dimensional, vector, Fourier-transform pair. In the far zone, the magnetic and electric fields uniquely determine one another so that $\nabla \times \bar{J}$ also determines the electric field; in fact, $\nabla \times \nabla \times \bar{J}$ and the far-zone electric field have been shown to be a Fourier-transform pair. The transform variables are position \bar{p} in the radiating current distribution, and direction cosines \bar{u} of the field point measured with respect to a right-hand coordinate system with origin in the radiating body. A proof of the statement that $\nabla \times \bar{J}$ determines the magnetic field follows.

The expression¹ for the magnetic field produced by a current distribution is

$$\bar{H}(\bar{u}, \lambda) = \frac{1}{4\pi} \int_V \bar{J} \times (\nabla \phi) dv, \quad (1)$$

where

$$\phi = \frac{\exp\left(-j \frac{2\pi r}{\lambda}\right)}{r}.$$

Using the vector identity $\bar{J} \times \nabla \phi = (\nabla \times \bar{J})\phi - \nabla \times (\bar{J}\phi)$, we can rewrite Eq. 1 as

$$\bar{H}(\bar{u}, \lambda) = \frac{1}{4\pi} \int_V (\nabla \times \bar{J})\phi dv - \frac{1}{4\pi} \int_V \nabla \times (\bar{J}\phi) dv. \quad (2)$$

The second volume integral can be converted to a surface integral by making use of the known formula

$$\int_V \nabla \times \bar{A} \, dv = \int_S \bar{n} \times \bar{A} \, da,$$

where \bar{n} is the outward directed normal to the surface S bounding the volume V . Equation 2 then becomes

$$\bar{H}(\bar{u}, \lambda) = \frac{1}{4\pi} \int_V (\nabla \times \bar{J})_\phi \, dv - \frac{1}{4\pi} \int_S \bar{n} \times (\bar{J}_\phi) \, da. \quad (3)$$

If the surface S is taken exterior to the current distribution so that \bar{J} is identically zero on S the surface integral vanishes, and Eq. 3 reduces to

$$\bar{H}(\bar{u}, \lambda) = \frac{1}{4\pi} \int_V (\nabla \times \bar{J})_\phi \, dv. \quad (4)$$

Equation 4 is true in all space exterior to the current distribution. We specialize to the far zone and Eq. 4 becomes

$$\bar{H}_{FZ}(\bar{u}, \lambda) = \frac{\exp\left(-j \frac{2\pi R_1}{\lambda}\right)}{4\pi R_1} \int [\nabla \times \bar{J}(\bar{\rho}, \lambda)] \exp\left(j \frac{2\pi \bar{\rho} \cdot \bar{u}}{\lambda}\right) d\bar{\rho}, \quad (5)$$

where R_1 is distance to the field point, \bar{u} is a unit vector in the direction of the field point and $d\bar{\rho} = dv$; this is clearly a Fourier integral. In the limit $\lambda \rightarrow \infty$ the radiation field $\bar{H}_{FZ} \rightarrow 0$, as it must, since $\int_V \nabla \times \bar{J} \, dv = \int_S \bar{n} \times \bar{J} \, da = 0$ when S is taken exterior to \bar{J} .

Equation 5 can be uniquely inverted only if the domain of direction cosines is taken to be infinite. Physically \bar{u} is constrained to the unit sphere, $\|\bar{u}\| = 1$, by the requirement that observation angles be real. It can be shown that inversion of Eq. 5, subject to the unit-sphere constraint yields $\nabla \times \bar{J}$ convolved with the function $(1/\lambda)^3 [(\sin 2\pi \|\bar{\rho}\|/\lambda)/(2\pi \|\bar{\rho}\|/\lambda)]$. Hence the physically observable, far-zone magnetic (or electric) field determines a smoothed version of $\nabla \times \bar{J}$.

J. R. Cummings

References

1. J. A. Stratton, Electromagnetic Theory (McGraw-Hill Book Company, Inc., New York, 1941), p. 466.

