

*YOU GIVE ME FEVER:*  
*Practical Protection for Metropolitan Neuroses*

by

Keith William Case

B.A. History of Art and Architecture  
Middlebury College, 2005

Submitted to the Department of Architecture in partial fulfillment of the requirements for the degree of Master of Architecture at the Massachusetts Institute of Technology.

February 2010

1

© 2010 Keith William Case. All rights reserved.

The author hereby grants to MIT permission to reproduce and to distribute publicly paper and electronic copies of this thesis document in whole or in part in any medium now known or hereafter created.

Signature of the Author: \_\_\_\_\_

Keith William Case  
Department of Architecture  
January 15, 2010

Certified by: \_\_\_\_\_

J. Meejin Yoon  
Associate Professor of Architecture  
Thesis Supervisor

Accepted by: \_\_\_\_\_

Julian Beinart  
Professor of Architecture  
Chair of the Department Committee  
on Graduate Students



*THESIS COMMITTEE*

J. Meejin Yoon

Associate Professor of Architecture

Andrew Scott

Associate Professor of Architecture

Ute Meta Bauer

Associate Professor of Visual Arts



*YOU GIVE ME FEVER:*  
*Practical Protection for Metropolitan Neuroses*

by

Keith William Case

Submitted to the Department of Architecture on January 15, 2010 in partial fulfillment of the requirements for the degree of Master of Architecture.

*ABSTRACT*

The emergence of Swine Flu in the past six months has once again heightened the world's fears of a coming flu pandemic. Although H1N1 is only slightly more pathogenic than the common seasonal flu, which kills approximately 30,000 Americans each year, its rapid transmission around the globe is nonetheless alarming and once again reveals the deficiencies in the government's detection, prevention and response. Currently few governments are adequately prepared for a possible outbreak.

5

After a century of reliance on antibiotics and vaccines, new and reemerging drug-resistant diseases expose the necessity of domestic biosecurity in addition to the national and international policies. Much like social unrest, wars and illnesses have in the past, the new pandemic crisis will shape architecture and urbanism dramatically. It will require a responsive and adaptable architecture that provides a nuanced relationship between living, working and socializing in a manner that does not forsake community for quarantine.

Thesis Supervisor:

J. Meejin Yoon  
Associate Professor of Architecture



# *YOU GIVE ME FEVER:*

*Practical Protection for Metropolitan Neuroses*

*Keith William Case  
M.Arch Thesis*

## *ACKNOWLEDGEMENTS*

Many thanks:

To my family for their support over the past three years

To Rachel, Charles, Ian, Marissa, and Chris for their friendship and encouragement

To Meejin for her insightful criticism

To my thesis committee for their wise input

To my friends at MIT who lent a hand during the final hours:  
Stephen Form, Adam Galletly, Ethan Lacy and Joseph O'Connor

## *THANK YOU*

# CONTENTS

<b>Theoretical Position</b>	<b>1</b>
<i>Historical Context</i>	
<i>Design Intent</i>	
<b>Precedents and Process</b>	<b>2</b>
<i>Precedent Analysis</i>	
<i>Material and Tectonic Studies</i>	
<b>Design Proposal</b>	<b>3</b>
Description	
Infrastructural Schematic	
Structural Schematic	
Architectural Drawings	
Model Images	
Renderings	
<b>Previous Incarnations</b>	<b>4</b>
<b>Appendix and References</b>	<b>5</b>
Excerpts from the US Model	
State Emergency Health Powers Act	
Endnotes	
Image Credits	
Bibliography of Works Consulted	



1

*Theoretical Position*

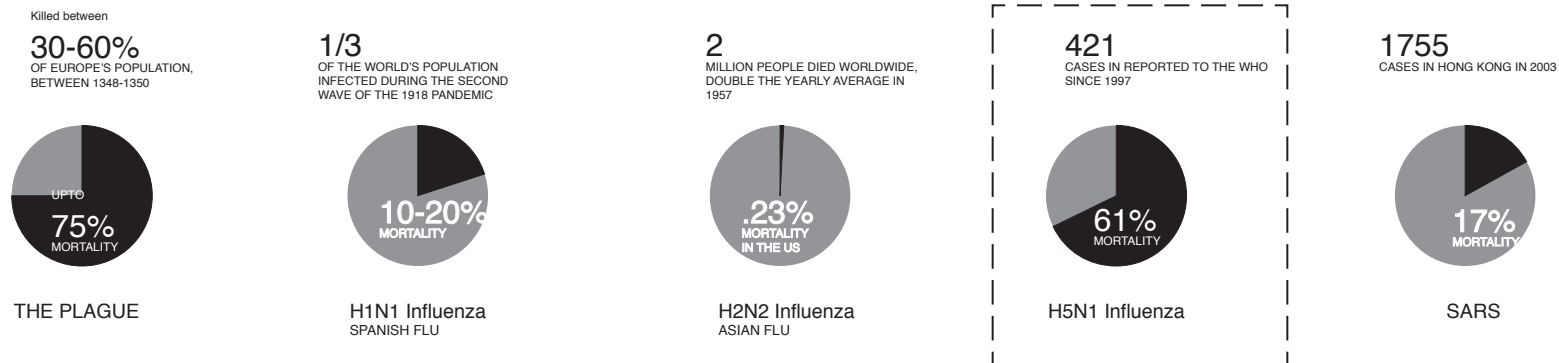

## THE ORIGINS OF THE FLU

The emergence of Swine Flu during the beginning of 2009 has once again heightened the world's fears of a global influenza pandemic. While initially thought to be only as deadly as the seasonal flu, which kills approximately 36,000 Americans each year, recent reports have added six thousand deaths to the US total in April,<sup>1</sup> making on track to be over twice as deadly<sup>2</sup>. Regardless of the numbers, more alarming has been the well-publicized and rapid transmission around the globe, bringing into relief the deficiencies in the government's response. Though thousands have died, H1N1 has not manifested itself as 'the big one' with sweeping societal effects like the Spanish Flu of 1918, which infected 500 million people<sup>3</sup>, and killed 1% of the human race<sup>4</sup>. In fact, it is not even the most pathogenic strand of influenza currently circulating. That distinction belongs to the Highly Pathogenic Avian Influenza, or Bird Flu (H5N1), which has a mortality rate in humans of above 30%<sup>5</sup>. H5N1 is currently endemic and inextinguishable in the waterfowl of South Asia, living silently among its hosts, only occasionally emerging as pathogenic in poultry, resulting in massive poultry culls

in China, Thailand and Vietnam<sup>6</sup>. Only in isolated cases, beginning in 1997 has the disease undergone sufficient antigenic shift to become transmissible to humans, resulting in human fatalities, usually confined to poultry workers. However, should the disease mutate further, acquiring the ability to be transmissible between humans, H5N1 would invariably set off a global pandemic killing 1 billion people in the worst case scenario<sup>7</sup>.

Development in China, Thailand and Vietnam increasingly impacts asian duck migration routes and wetland habitats. As South Asian cities grow at their periphery, their expanding industrialized food production system, which includes poultry and pig farms, come in increasing proximity to virus-carrying waterfowl. While Vietnamese and Thai farmers used to raise smaller flocks, Tyson-style production has emerged to meet China's growing market. These massive industrial chicken farms offer an unlimited breeding ground for new viruses, which by sheer number foil attempts at vaccination. Often the only recourse is to cull the entire flock, but because only a few countries offer full reimbursement for culling poultry, farmers frequently collect government remuneration but sell infected meat anyway, or resist culling their entire flock to preserve their financial security. The industrialized farms are not the only problem, the wetmarkets commonly found

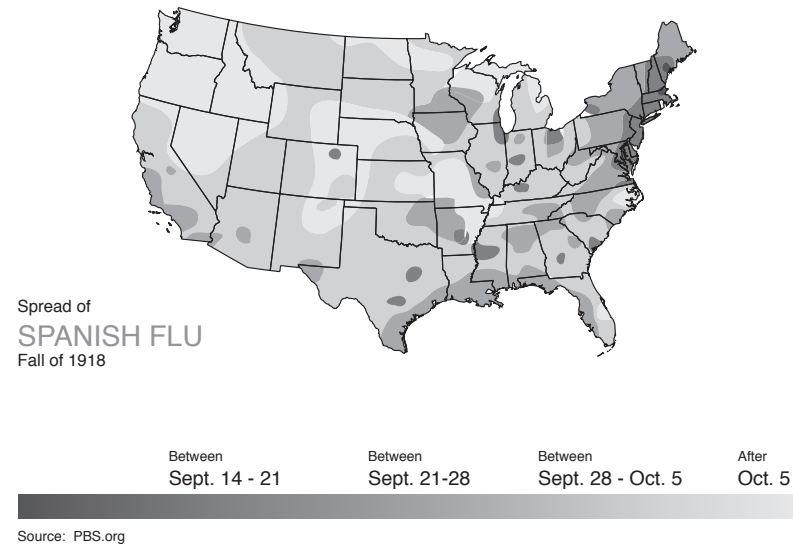
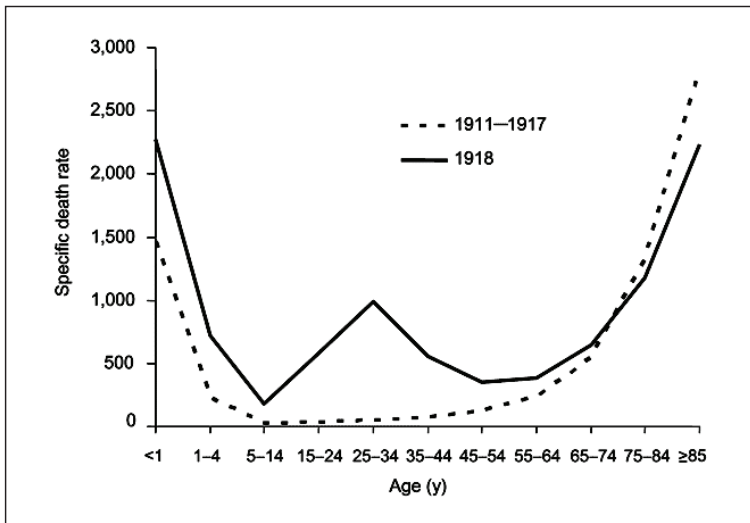

in many South Asian cities bring those chickens and ducks into the heart of the city, unleashing a host of new strains of influenza each year on the human population.

While the flu originates in fowl, pigs often act as virus incubators of both avian and human influenza strains. Within the respiratory system of pigs (which bears similarity to humans'), human and avian strains recombine genetically. While antigenic drift (the continual process by which proteins change amino acids to create modified strains of flu, each requiring a new vaccine) occurs each flu season, occasionally avian strain trades genes with a human influenza strains, and acquire the ability to infect humans. This process of recombination is called antigenic shift. Because of the radical genetic transformation, humans do not have existing antibodies or immunological memory to fight the disease. The recurrence of such an event means that influenza is a "constantly emerging disease."<sup>8</sup> Many epidemiologists fear that these

pig farms, in close proximity to major world cities, will be the source of a subtle but critical antigenic shift of the endemic Avian Influenza, whereby it may acquire the ability to be transmissible between humans, setting off a deadly global pandemic.

The Pearl River Delta, China, the source of the seasonal flu<sup>9</sup> is an area of vast manufacturing potential, inextricably linked to the US and Europe through global capital. The era of high-speed transportation and globalization means that H5N1 could be on the shores of the US within sixteen hours of emerging in Asia, and within 30 to 90 days could infect the entire US<sup>10</sup>. While the US government has production contracts with Novartis and the UK with GlaxoSmithKline to supply the country with millions of doses of seasonal flu

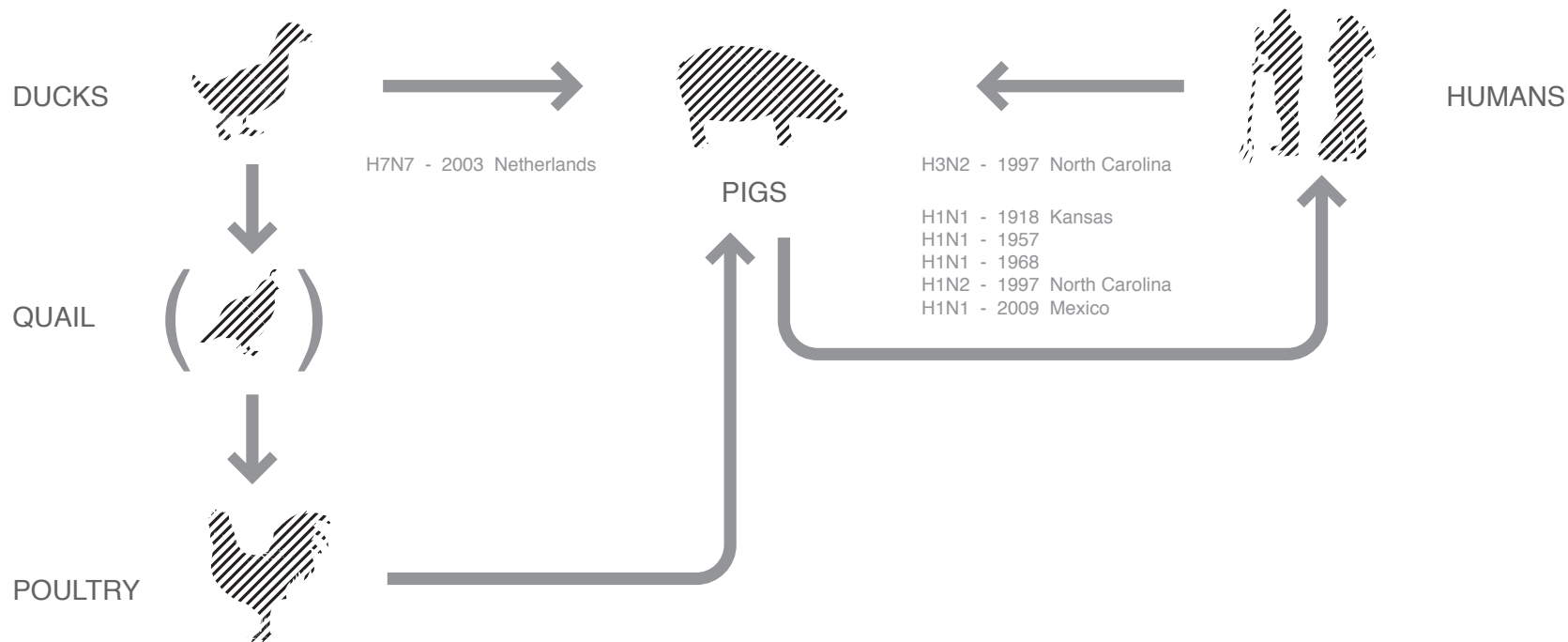

14

### ANITGENIC SHIFT

vaccine, the continual antigenic drift of the virus makes it impossible to stockpile, and new vaccines typically take six months to become available once a new strain has been identified. Complicating the situation, drug companies are hesitant to release untested vaccines to the public because it leaves the company liable for any drug complications in addition to the financial burden of producing a potentially unprofitable drug.<sup>11</sup> Despite the development of a worldwide surveillance network headed by the Centers for Disease Control and Prevention and the World Health Organization, the nature of the flu makes it difficult to quickly identify, as it often hides among secondary infections and is commonly misdiagnosed as any number of bronchial infections or

ailments. In addition, federal officials are hesitant to declare a state of emergency and the Chinese Government as well as other authoritarian states of Southeast Asia, which could be the sentinels of new strains, have in the past covered up or minimized outbreaks, as was the case with Severe Acute Respiratory Syndrome (SARS) in 2003,<sup>12</sup> for fear of the economic and political toll a pandemic would wreak on their country. All of which contribute to a delayed response time to an outbreak of what could be a devastating new virus, the speed of which far outpaces the response.

Currently few governments are adequately prepared for a possible outbreak despite The World Health Organization's Global Influenza Preparedness Plan, a document drafted to help assess the risk of new strains of influenza and facilitate management of an outbreak. De-

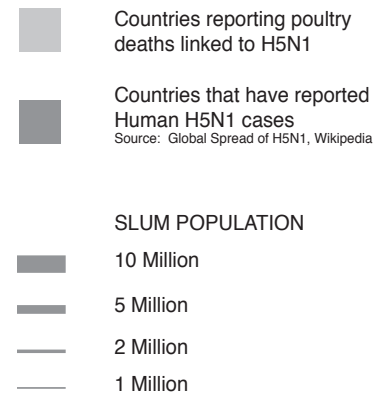

spite the \$3.7 billion since September 11, 2001 the U.S. has devoted to “emergency preparedness for bioterrorism, infectious disease outbreaks and public health emergencies,”<sup>13</sup> the emergency infrastructure collapsed during a May 2003 mock casualty exercise in Chicago. It became clear that the federal government’s reliance on a constellation of state and local healthcare and emergency systems was a serious impediment to implementing a national biodefense strategy.<sup>14</sup>

Similar to the situation during The Cold War, the responsibility of defense has shifted away from a government perceived as inefficient

and ineffective, to the individual<sup>15</sup>. While atomic annihilation was an acute event, the flu recurs in waves and continually mutates to resist antibiotics. As long as the fundamental causes of disease: poor sanitation, overcrowding, access to healthcare and habitat destruction are not addressed on a world-wide scale, influenza will continue to emerge in new and virulent forms. Many epidemiologists are surprised that these seemingly perfect conditions in South Asia, facilitated by rapid transportation and inadequate healthcare systems have not yet caused a global pandemic that rivals 1918. But they agree that it is inevitable, and this pandemic will assuredly not be the last<sup>16</sup>.



Littoral Diseases

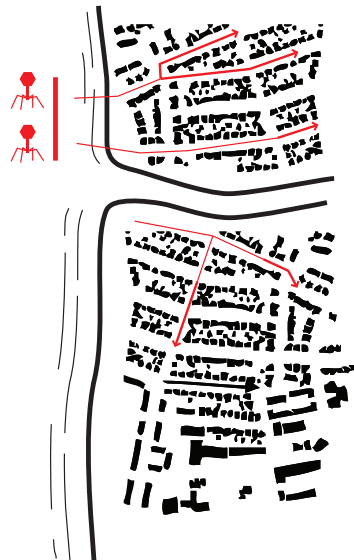

Quarantine

## BIOSECURITY IN HISTORY

With regards to architecture, there has been a dominant trend in the last millennia towards greater atomization of biosecurity. The first approaches towards protection emerged during the middle ages and were focussed on isolating villages and cities from all externalities, but as technology and society advanced, specific architectures emerged in response to the threat of diseases.

During the growth of international trade during the Roman Empire new diseases found fertile ground for incubation on both sea-faring vessels and in the port cities of Europe. Typically diseases spread outward from these ports into their hinterlands along trade routes. To combat these diseases cities enacted two forms of protection. The first, which was rarely used, was the sanitary cordon, a strict border around the city meant to prevent the interaction between the city and outsiders. Often breached and ineffective, this method stifled trade and was only ever used in isolated areas.<sup>17</sup> Since the Middle Ages, quarantines have been the dominant method to stem the flow of disease vectors into port cities. Quarantine, which applied to cargo and passengers alike, was a mandatory forty day waiting period during which the suspected ship was held at anchor outside of the city quays. Quarantines were later shortened to 20 and 15 days, depending on the port and period. Despite their long history, city-level quarantines were a relatively ineffective tool to stop disease. Early port quarantines lacked the level of surveillance and coordination to successfully prevent the spread of disease and it was not until the 20th century that there arose an international body to coordinate the issuance of bills of health.<sup>18</sup> Before that time there was little trust in international sanitary conditions, and the spread of disease became politicized.

Once a disease was endemic to the population, there was little recourse but to isolate the symptomatic individuals in the Lazaretto. Named after St. Lazar, the patron saint of lepers, these militarized enclosures were used for centuries for any number of diseases. While quarantine was instituted to isolate ships from suspect ports to

ensure they are not carrying plague or communicable diseases, the Lazaretto was a form of quarantine for afflicted individuals, a variation of the pesthouse except individuals may return to the city after they have been cured of their affliction unless they have died.

Technology has both helped and hindered the process of disease surveillance, detection and communication. Prior to the 19th century the fastest forms of travel were still measured in days, enough time for individuals to manifest symptoms of an infectious disease, giving the destination ports the opportunity to enact quarantines and brace for the effects of the disease. The acceleration of transportation during the 20th century has allowed pathogens to enter cities surreptitiously, emerging after they have already infected dozens. Ironically, the same advances in communication and transportation that have facilitated surveillance, treatments and coordination have allowed diseases to spread even more quickly.

Architecture has played a role in the past in the treatment of diseases, not just in the form of hospitals, but as instruments of health themselves. The sanatoria of the 19th century used orientation, light and air as agents of health in the days before the availability of vaccines. While previous generations have used the salubrious qualities of the architecture to prevent/treat/cure diseases, in the age of rapidly mutating and globally footloose viruses the role of architecture has shifted to that of prevention/protection/preservation. However, architecture itself has been implicated as a disease vector, requiring a finer grain of intervention to provide maximum bio-security. One specific instance would be the case of Amoy Gardens in Hong Kong.

The dominant trend had been towards increasingly smaller interventions into the cityscape, from the city walls and shores, to just shy of the house. As architecture began to be mobilized under the nascent modernism as a weapon against the miasmatic medieval city, advances in the fields of medicine and epidemiology had developed drugs and anti-virals that replaced these physical and corporeal interventions.



17

*The Lazaretto*

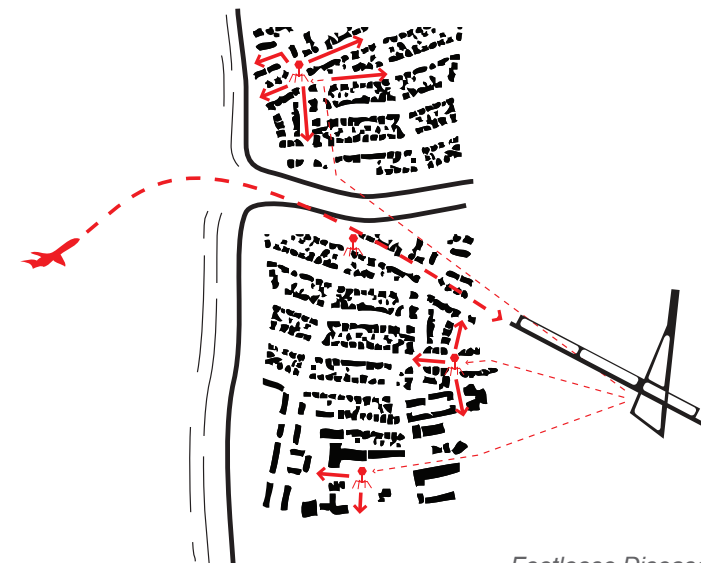

*Footloose Diseases*

## Amoy Gardens, Hong Kong

The example of Amoy Garden represents an interesting case of a disease spread not only through close and direct contact, but facilitated by the building itself. Unforeseen aspects of the building, including the airflow around the blocks, the dimensions of the light wells, orientation of the units and the cleanliness and maintenance of the sewage system all contributed to a much faster transmission rate of the disease than would be expected from a single index patient.

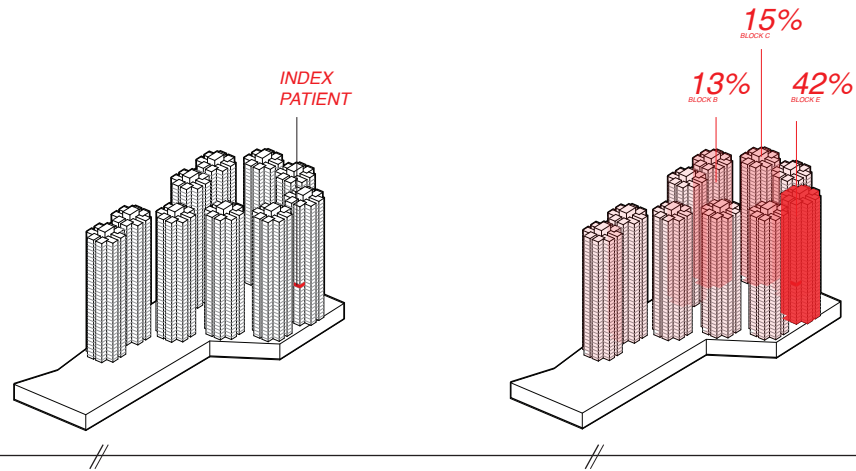

MARCH 12, 2003

WHO issues global alert concerning a new infectious disease in Hong Kong

MARCH 14-19, 2003

The index patient visits his brother on the seventh floor, flat seven in Block E of Amoy Gardens, Kowloon

MARCH 24, 2003

The disease spreads throughout Amoy Gardens, peaking at 321 cases, distributed throughout the 19 blocks but concentrated mostly in blocks E, B, C, D. Within Block E, Units 7 and 8 have the greatest concentration of infections at 73% and 42% of the population

## ARCHITECTURE AS DISEASE VECTOR

But a century of reliance on drug therapies has unleashed a host of new and re-emerging diseases that resist those drugs, and scourges of the past, thought to be extinct in the modern world are re-emerging, as is the case with drug resistant tuberculosis, whose treatment can last as long as five months.<sup>19</sup>

In facing these new drug-resistant diseases, it is the intention of the project to pick up where history had left off over a century ago, namely the logical progression

towards a domestic biosecurity. Even though the government may now have the technology and resources to attack these disease as they emerge, it has been neutered by the requirement to preserve the civil rights of its citizens and to protect trade relations with its neighbors. Through the US Model State Emergency Health Powers Act, states have sought to balance the government's power with individual rights. Ultimately the act, which has only been ratified by half the states, would not go nearly far enough to effectively quash an emerging pandemic and as a result, the onus increasingly falls on the citizens for their own protection.

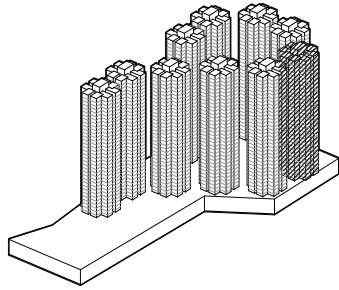

*MARCH 30, 2003*  
Authorities quarantine Block E. The Balcony is closed and guarded by police

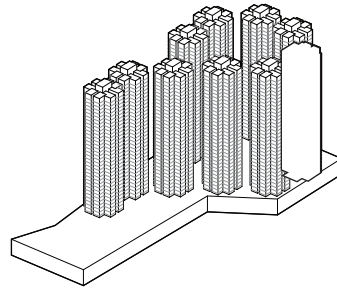

*APRIL 1, 2003*  
Residents are evacuated to Lei Yue Mun Holiday Camp. Two days later, protests arise over washroom sharing

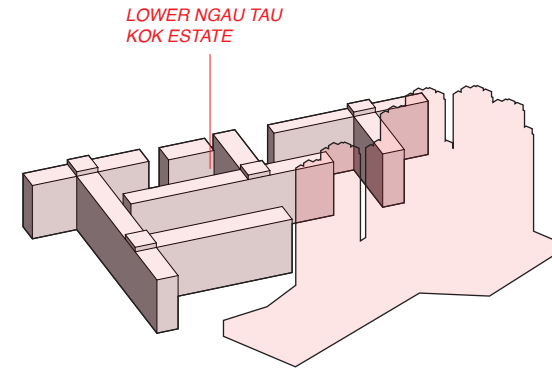

*APRIL 8, 2003*  
SARS begins to affect residents in Lower Ngau Tau Kok Estate, adjacent to Amoy Gardens

This project situates itself in between two paradigms, the architecture of civil defense, and the architecture of health. As it becomes clear that maintaining civil liberties may put the general public at risk, methods of domestic biosecurity will become necessary elements of the built environment. For that reasons this project resonates most with the prefabricated bomb shelters of WWII and the Cold War in both use and scale. At times of crisis, individuals are not only looking for a contingency plan independent of national and international policies and procedures, but also a piece of mind.

## *INTERPANDEMIC PERIOD*

### *DETECT AND REPORT*

## *PANDEMIC ALERT PERIOD*

### *IDENTIFY VIRUS SUBTYPE*

#### *PHASE 1*

No new influenza subtypes have been detected in humans. An influenza virus subtype that has caused human infection may be present in animals. Low risk of human infection.

#### *PHASE 2*

A circulating animal influenza virus subtype poses a substantial risk of human disease, but no subtypes present in humans.

#### *PHASE 3*

Human infections with new subtype, but no human-to-human transmission, or rare instances of spread in close contact.

### *NUMBER AFFECTED*

Undetermined source of infection, or isolated family outbreak. Spread of virus to a close household.

### *RESPONSE*

Verify availability and distribution procedures for personal protective equipment and antivirals and for vaccine for the protection of persons at occupational risk, consider measures to implement

Identify priority geographical areas and risk groups for targeting with preventive measures.

Consider deploying supplies of antivirals for post- and pre-exposure prophylaxis.

## *GLOBAL INFLUENZA PREPAREDNESS PLAN*

*WORLD HEALTH ORGANIZATION*

In 2005 the World Health Organization established a Global Influenza Preparedness Plan to assist member states in responding to the threat of Pandemic Influenza, mainly in response to the growing threat of Highly Pathogenic Avian Influenza, which ripped through Asian poultry flocks in 2003. The plan outlines new phases Classifying a pandemic, and recommends actions during each phase to be undertaken by the relevant national authorities. The plan also outlines the relationships and responsibilities of the WHO during a crisis, and its role in surveillance, detection, communication and containment.

*PANDEMIC PERIOD*

*DEVELOP VACCINE  
CONTAIN VIRUS*

*CONTAIN AND DELAY  
VIRUS*

*MINIMIZE PANDEMIC  
IMPACT*

*POSTPANDEMIC PERIOD*

*PHASE 4*

Small clusters with limited human-to-human transmission but spread is highly localized, suggesting that the virus is not well adapted to humans.

One or more small clusters, fewer than 25 persons, with symptoms lasting less than two weeks. Most likely human-to-human transmission.

Coordinate the implementation procedures that will delay or contain the spread of human infection.

Activate command and control response activities, deploy operational response teams Coordinate with countries with common borders.

Activate procedures to obtain additional resources; consider invoking emergency powers.

Implement surge-capacity arrangements and contingency plans for staff shortages in health-care facilities. Consider deploying prototype vaccine

*PHASE 5*

Larger clusters but human-to-human spread still localized, suggesting that the virus is becoming increasingly better adapted to humans, but may not yet be fully transmissible.

Ongoing cluster transmissions of 25-50 people lasting between two and four weeks. Localized transmission, eg. universities, villages

Prepare for pandemic.

**Declare State of Emergency**

Likely the last chance for massive coordinated global intervention, targeted to one or more foci, to delay or contain spread.

Real-time monitoring of medical supplies, pharmaceuticals, infrastructure, vaccines, hospital capacity, human resources.

Enhance surveillance to maximum intensity. Implement prophylaxis as emergency countermeasure

Begin prioritization of health-care services and supplies, travel restrictions, shortages of basic commodities. Implement corpse-management procedures

*PHASE 6*

Pandemic: Increased and sustained transmission in general population.

Activate national command and control operations

Assess uptake and impact of: treatments and countermeasures, including vaccine/antiviral efficacy and safety and emergence of antiviral resistance; non-pharmaceutical interventions; etc.

Voluntary home confinement of symptomatic persons, closure of schools, furlough non-essential workers, close workplaces, discourage mass gatherings. Thermal scanning at borders.

*PHASE 1*

Return to interpandemic period.



2

*Precedents and Process*

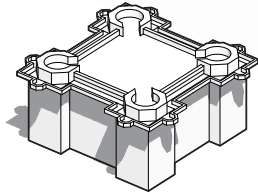

**4900** m<sup>2</sup> **18,000**  
FOOTPRINT PERSONS

**24,500** m<sup>2</sup> **7,300**  
TOTAL AREA PERSONS PER HA

**HEILIGENGEISTFELD**  
G-TOWER - HAMBURG

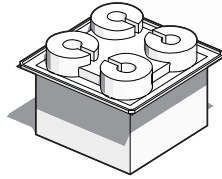

**3249** m<sup>2</sup> **18,000**  
FOOTPRINT PERSONS

**16,250** m<sup>2</sup> **11,076**  
TOTAL AREA PERSONS PER HA

**WILHEMSBURG**  
G-TOWER - HAMBURG

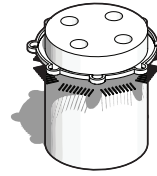

**1400** m<sup>2</sup> **50** m  
FOOTPRINT HEIGHT

**16,800** m<sup>2</sup>  
TOTAL AREA

**AUERGARTEN**  
L-TOWER - VIENNA

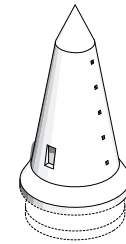

**10** m<sup>2</sup> **500**  
FOOTPRINT POPULATION

**80** m<sup>2</sup> **62,000**  
TOTAL AREA PERSONS PER HA

**WINKELTURM**  
BOMB SHELTER

## BOMB SHELTERS AND CIVIL DEFENSE

Perhaps the best example of comprehensive military and civilian defense may be the Flak Towers and Hochbunkers that ringed key cities in Germany and Austria during the Second World War. As part of a defensive strategy to deflect allied attacks on the homeland, the Nazis built several types of towers that served as installations for anti-aircraft weaponry, relay stations for military coordination and defense for the civilian population. The robust construction of the towers served the dual role of not only protecting the gun placements but also creating a protected interior, which proved to be one of the safest places in Berlin during allied attacks. Built from reinforced concrete, the walls were several meters thick and were virtually impenetrable. While there were many underground bunkers and shelters, it can be assumed that the conspicuousness of these towers made them not only symbolic of the Berlin defenses, but also their own civil defense signposts,

directing any unfortunate pedestrians towards a place of refuge.

A slightly smaller example of civilian defense during the war was the Winkeltürme, named for Leo Winkel of Duisburg. Winkel patented his design in 1934, and from 1936 on, Germany built 98 Winkeltürme of five different types. These structures had a small footprint which made them difficult targets and had curved walls, which were believed to deflect blasts, much like the bunkers of the Atlantic Wall.<sup>20</sup>

While the Flak Towers of Berlin represent a typology of buildings, much like the Atlantic Wall, they were individual structures, built one at a time at an enormous cost of labor and materials. As the scale of the shelter becomes smaller, their purposes become more specialized and became a manufactured element within the industrial war machine. Smaller structures could be packaged into kits and sold to civilians or easily built offsite and brought in prefabricated, and indeed the survival rate was much improved thanks to the coordinated effort that dispersed shelters to the residents of London. Civil Defense

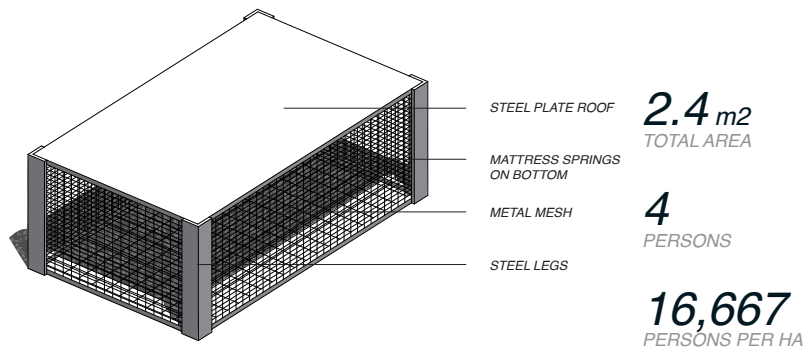

MORRISON SHELTER

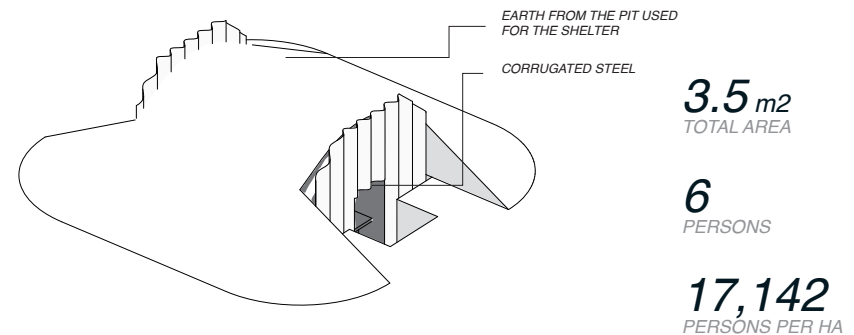

ANDERSON SHELTER

during the Axis bombing campaign in Great Britain during World War II had two directions, make-shift community shelters were created in the tunnels of the London Underground, which served most of the population who sought shelter, and a campaign to produce affordable personal shelters designed for Londoners' homes. Two notable designs were pre-manufactured and made available to the public at subsidized rates through the government.

The Anderson shelter was designed to protect between four and six people during aerial bombardments during World War II. The shelter was designed according to the average household size of the population living in the terrace houses of London and was sized to fit in a common backyard.<sup>21</sup> It was constructed from a kit that included fourteen sheets of corrugated steel, dimensional lumber, nuts, bolts and washers. Six Arched steel sheets formed the body of the structure, with two larger panels acting as protection on the ends. There was no door in the shelter, rather inhabitants would block the entrance with sacks or blankets. Typically the shelters were buried partially

underground and covered with at least a foot of earth. The earth berm covering the shelter doubled as a place to grow vegetables during the rationing period, and awards were given out for the best planted shelter.

The design was very simple, designed, drafted, tested and sent to production with three weeks in 1938. The shelters were designed to ensure that there was enough air for four people during an attack, that the shelters were easily accessible during emergencies and that they had a utility after the conflict was over. The shelters were easy to erect and cheap, but had poor ventilation, were cold and often damp. The conditions inside precluded them from being used nightly for protection, rather they were typically only used in emergencies. Even though the Luftwaffe switched from daytime to nighttime bombing, shelters were not universally used. In 1940, only 27% of Londoners slept in their Anderson Shelters, 9% used public shelters and 4%

used underground stations. 2.25 million shelters were delivered throughout the war to UK residents, beginning in 1939. The shelters were free for those families earning less than 250£ sterling and only 7£ for those over the limit.<sup>22</sup>

In 1941 the government began issuing Morrison Shelters as an alternative for families who did not have a basement or a yard for an Anderson shelter. Anderson shelters were unsafe to use inside of existing buildings because of the possibility of trapping the inhabitants inside if there were a fire or gas leak following an attack. The Morrison's mesh sides provided greater ventilation and the shelter was easy to enter and exit. Morrison Shelters, officially called a Table Indoor Shelter, were little more than a mattress with mesh sides and a steel top. (A two-level version was produced in addition to the single table style) The sides deformed as debris fell on the ceiling, but kept the family safe. There was room for approximately four people. The sides were removable to allow the shelter to be used as a table. They came in kits of 359 parts and 3 tools and were available for free to those who made less than 350£ a year. By 1942, 500,000 had been distributed and 100,000 more in 1943 as the Nazis began attacking using the V1 Flying Bomb. The shelter was very effective when sited correctly and could withstand most bombardments excluding a direct hit.

At the smallest scale, Germany was prefabricating the Einmann-Luftschutzbunker, a one-man bunker meant to be installed at rail depots and other infrastructure sites across Germany that would likely be targets for Allied bombers. They were size to fit one person standing, and were only meant to be occupied for brief

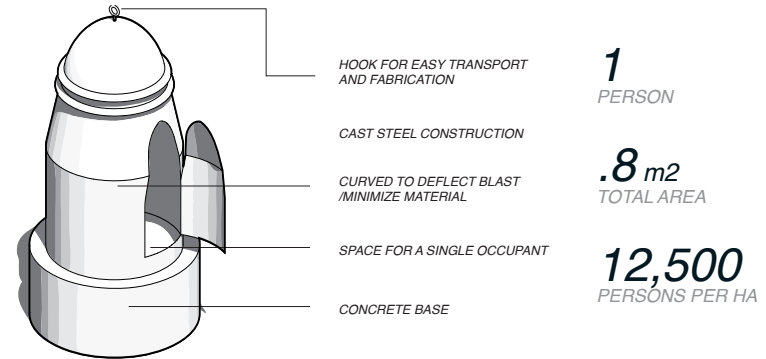

*EINMANN-LUFTSCHUTZBUNKER*

periods during an attack. They were were cheap and easily installed but had limited application beyond immediate protection.

The table was an example of the beginning of the domestication of civil defense, which would reach a new level during the second half of the twentieth century, as fallout shelters were designed to double as dens and playrooms, and the safe room became an architectural element that was built into new houses. It has been estimated that by 1965, around 200,000 fallout shelters had been built. Roughly one for every nine hundred persons, or one for every 266 households. A small number when considering that 53% of Americans believed that a nuclear war was likely to occur<sup>23</sup>. At first fallout shelters were generally embraced, but it only took two years for them to be discredited. Initially pushed by the Civil Defense Department, they were invoked as the only sure way to ensure the safety of the family in the event of a nuclear disaster, but their efficiency was increasingly called into question. In addition, the existence of a fallout shelter in the backyard cast a pall over suburban life. Their ability to survive a nuclear attack was dubious, and hundreds of shelter building firms that gouged consumers began to discredit the enterprise. Constructing shelters in urban areas would have been prohibitively expensive and futile given

the warning time was typically only 3-5 minutes prior to a nuclear event.

While the Kennedy Administration's initial position held the family responsible for their own safety and the government in charge of foreign policy, their tactic shifted towards community shelters due in part because of blow back from shifty shelter builders and the growing unease with "shelter morality." The laissez-faire approach to shelter building also revealed an embedded class bias in society. "That nuclear survival was enhanced by residency in the suburbs was noted by others, including John Kenneth Galbraith. In a letter to Kennedy, Galbraith called the suburban bias of the fallout shelter program "a design for saving Republicans and sacrificing Democrats."<sup>24</sup> One approach taken by Denver in the early sixties was to build neighborhood shelters for twenty families, in which families would buy stock at \$1200 to \$1500, making shelters more economical and reducing the moral decisions that needed to be made in the worst case.<sup>25</sup>

## THE ARCHITECTURE OF DEFENSE

An architecture of protection has always had a tenuous relationship with the human psyche. It is debatable how close the US and the USSR came to a nuclear war, but part of what prevented the wholesale adoption of nuclear countermeasures and fallout shelters was the psychological presence of a fallout shelter itself, which stood as a continual reminder of the tense nuclear standoff.<sup>26</sup> In addition to many, the prospect of hiding underground while at war with the Soviet Union felt distinctly un-American. Americans were unwilling to give into a fear that would alter their lives. In addition there was the commonly held belief that the survivors would envy the dead upon inheriting a decimated landscape with a fractured and dispersed population that in no way resembles the country they left behind.

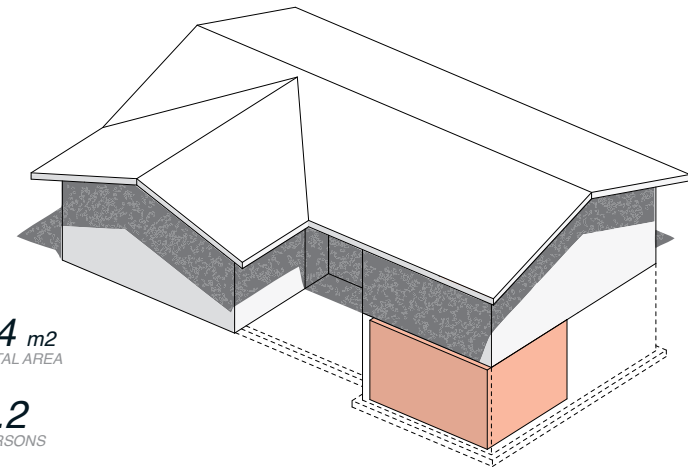

14 m<sup>2</sup>  
TOTAL AREA

4.2  
PERSONS

300  
PERSONS PER HA

BASEMENT FALLOUT SHELTER

The condition for surviving a pandemic however would be much different, and while populations may be decimated, the physical geography of the planet would remain unchanged. Protection from a pandemic need not have the same level of physical protection from cataclysmic events, which allows greater liberty in designing pandemic-proof shelter. Because of the forces bomb shelters are required to repel, there was little ability for them to expand, be portable, adaptable or communicative. The question remains, how to design an architecture that both protects the inhabitants from the transmission of pandemic viruses, while retaining a connectivity to the context and functionality?

## THE IMAGE OF PROTECTION

### *Design Precedents*

While the project is concerned with protection of the inhabitants from the environment, a critical factor in its design is the impression of protection it provides. Because it is a relatively novel consumer product, it is critical that the project convey the image of protection. Formally the project looks to the emerging architecture of healthcare devices and products from the last century. These products exist between the scale of industrial design and architecture. It is a realm of corporeal augmentations that approach what could be considered 'habitable.'

28

One source of inspiration is the iron lung, which first became prevalent during the polio outbreak of the early twentieth century. Paralysis of the autonomic nervous system required breathing assistance, which the iron lung provides by means of an oscillating partial vacuum around the patient's chest. The negative pressure inside the chamber expands and contracts the patients lungs much like the diaphragm muscles would on a healthy patient. Although direct intubation has become the de facto method of treating respiratory failure, the use of the iron lung has persisted for treating certain ailments. While it has fallen out of favor, a new product from the U.K., first tested in 2008 at Children's Hospital, Buffalo, is paving the way towards a revival of negative pressure ventilation to treat cystic fibrosis, asthma and emphysema. Biphase Cuirass Ventilation, essentially a portable iron lung uses the same concept, but is more compact and uses updated technology. BCV is not as invasive as intubation, and prevents the harmful build up of CO<sub>2</sub> and fluids in the lung as well as the trauma to the patient. It is more natural and al-

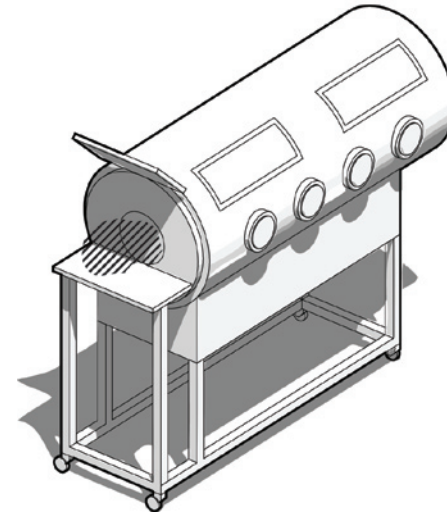

*The Iron Lung*

lows the patient to be weaned off of the ventilator when possible.

This project draws inspiration from the materiality and the adaptability of these medical devices. Contemporary medical devices use plastics not only for their durability and ease of manufacturing, but because they are also easily cleaned and can take on many biomorphic forms only available through a thermoplastic manufacturing process. Vinyl and latex provide vision and light through the device while protecting the individual from exterior forces. The scale of the project, protection for two to four individuals, suggests the same manufacturing system and componentized delivery method as well as similar materials. Because this project is subject to repeated use by many different individuals, just like the iron lung or defibrillator, ease of disinfecting is a priority and is partly responsible for the 'hospital corners' aesthetic. Much like healthcare machines, this project attempts to eliminate extraneous elements, resulting in a streamlined exercise in minimal

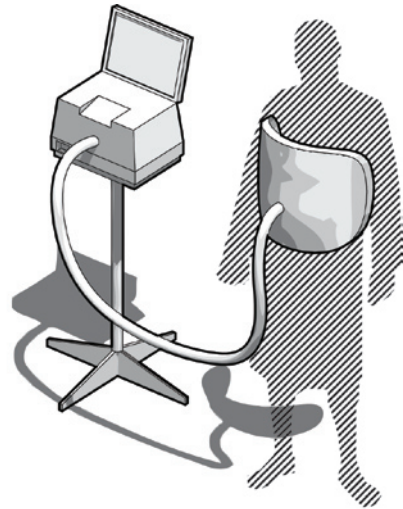

*Biphasic Cuirass Ventilation System*

living. This hybrid, body-scaled architecture can exist within the larger built environment, between the building and room scale. It is a secondary, subversive and personal architecture that forsakes its immediate context to provide protection.

Additionally this project was inspired by the micro architecture of Richard Horden for its portability, self-contained systems, multi-use spaces and its ability to adapt to varying site conditions, as well as the inventive inversions of R&Sie Architects, whose Mosquito Bottleneck suggests a new paradigm of living in proximity to immediate threats.



*"What not to wear when worrying about the flu"*



*Fashion Flu Masks, Nuvo Accessories*

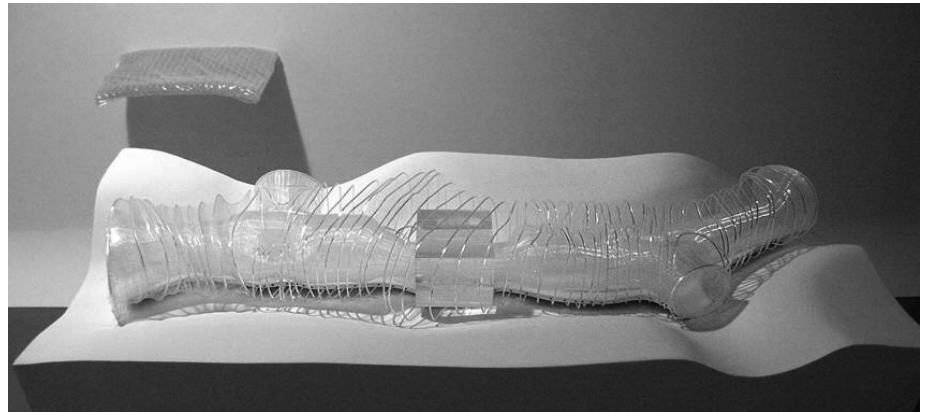

*MOSQUITO BOTTLENECK, Trinidad, R&Sie Architects*

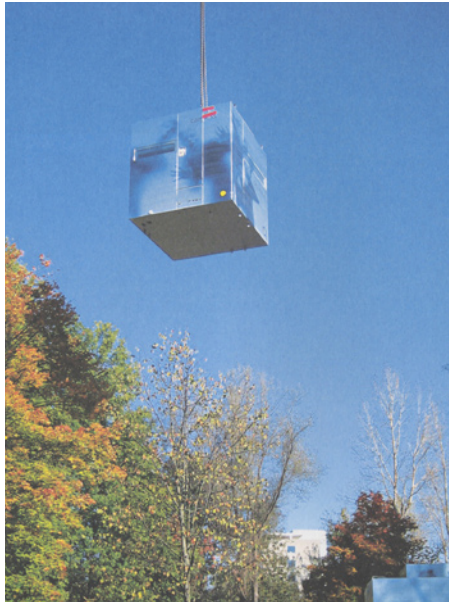

*Micro Compact Home - Horden Cherry Lee Architects*



*The Spandrobe - Kohn Shnier Architects*

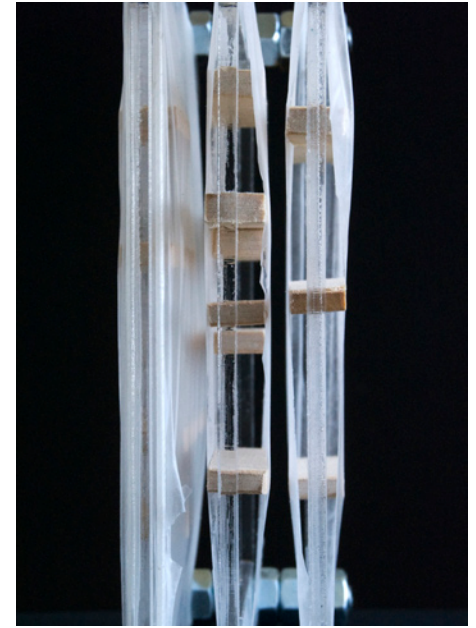

*Material and Tectonic Studies*

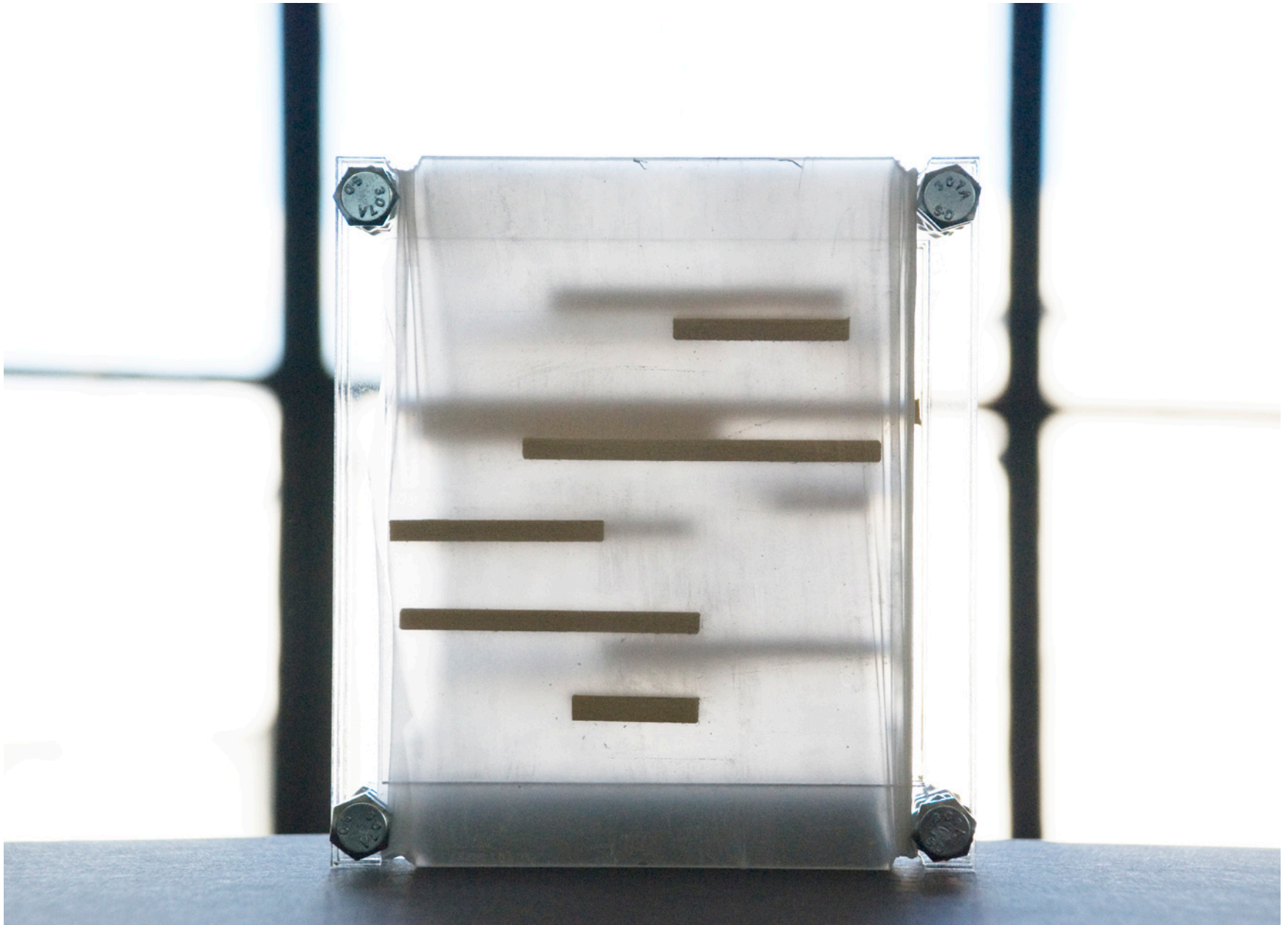

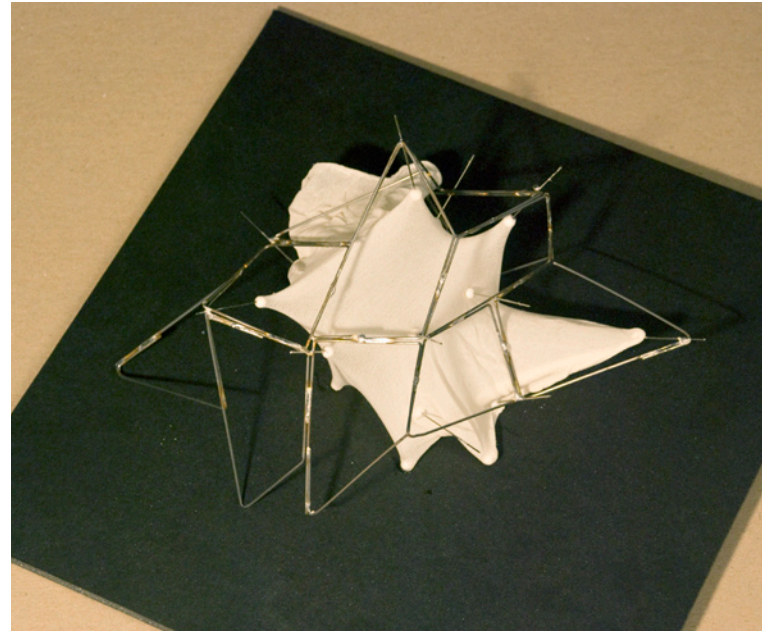
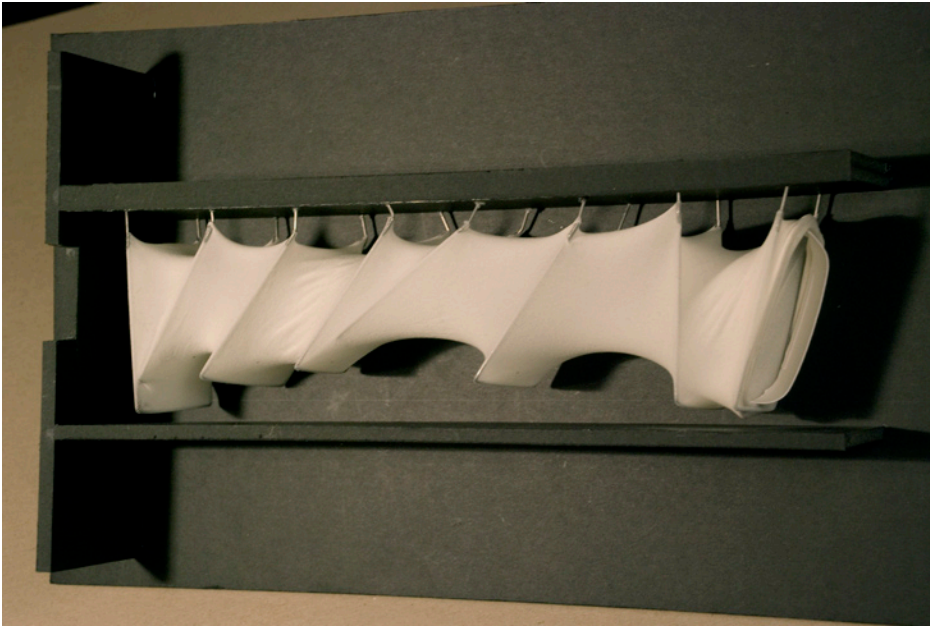

*Material and Tectonic Studies*

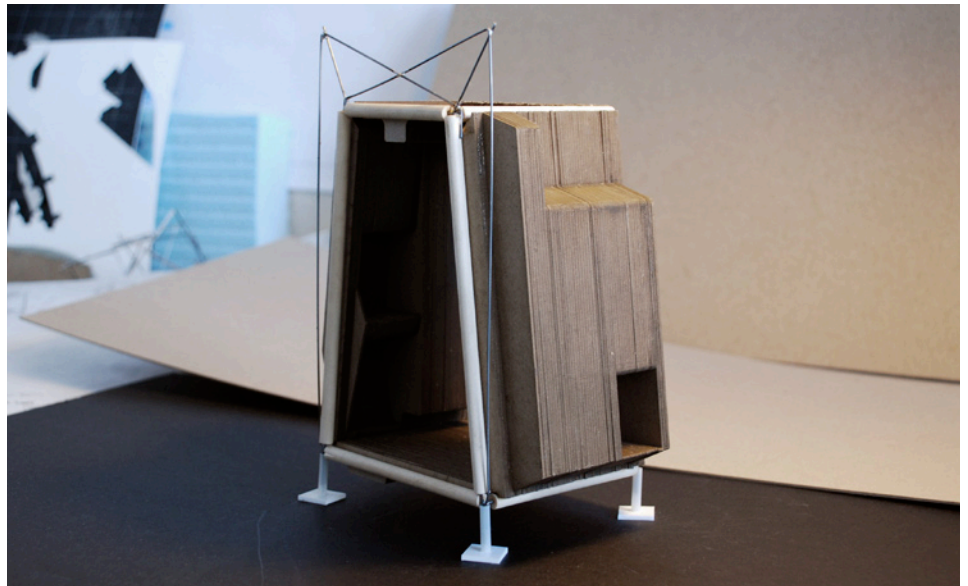
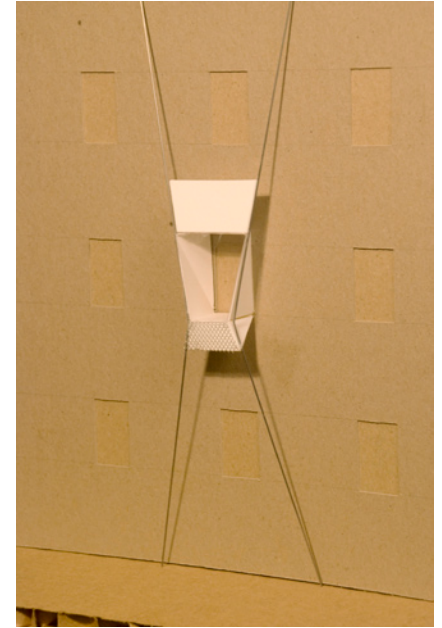
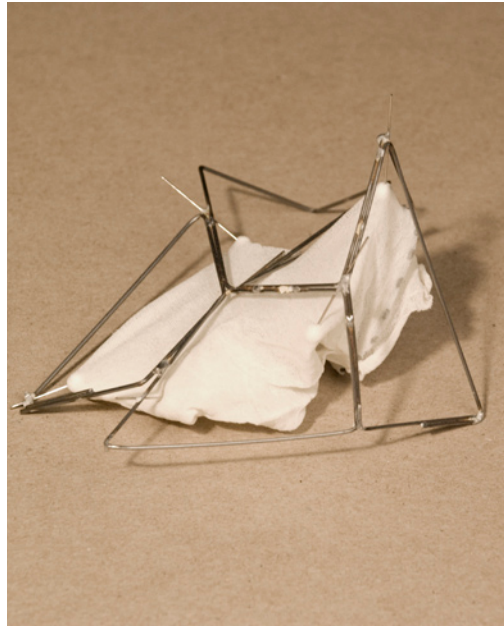
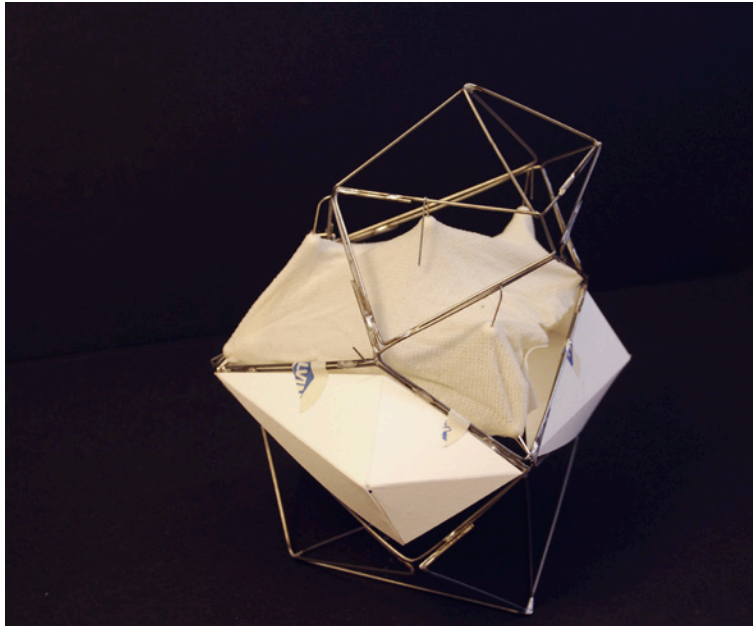





3

*Design Proposal*

## *DESIGN PROPOSAL*

The final configuration is an invacuation pod for individuals or families in the face of a global pandemic. It is intended to be a subscription service, much like what was pioneered in certain communities during the early sixties for civil defense, whereby individuals purchase shares in a national supply of invacuation pods. These pods, which are stored off-site can be deployed at a moments notice within a house or apartment should the anxiety of navigating a pandemic city become too great. Although the unit is designed for invacuation, it could be imagined that in certain situations, it could serve effectively as in-house quarantine unit. Depending on the pervasiveness of the pandemic, there might exist a moment when the number of sick out number the healthy by a margin that calls into question the idea of invacuation, and quarantine might become the dominant method of containing the disease.

The project is designed around a titanium tube space truss structure, which is the dominant structural system, into which plug carbon fiber programmatic pods. The standardized bay spacing allows the customer to choose any combination program pods that provide spaces for sleeping, eating, socializing, and bathing among other uses. The base configuration of essential pods fits entirely within a common apartment, with only a small portion protruding out of a window to access light and air, however this base unit can be expanded with additional pods and structure, building on air rights above sidewalks and streets.

1. ETFE Pillows
2. Infrastructure Pod
3. Waste + Sanitation Pod
4. Shear Cables
5. Tapered Titanium Tube Structure
6. Ceiling Plenum

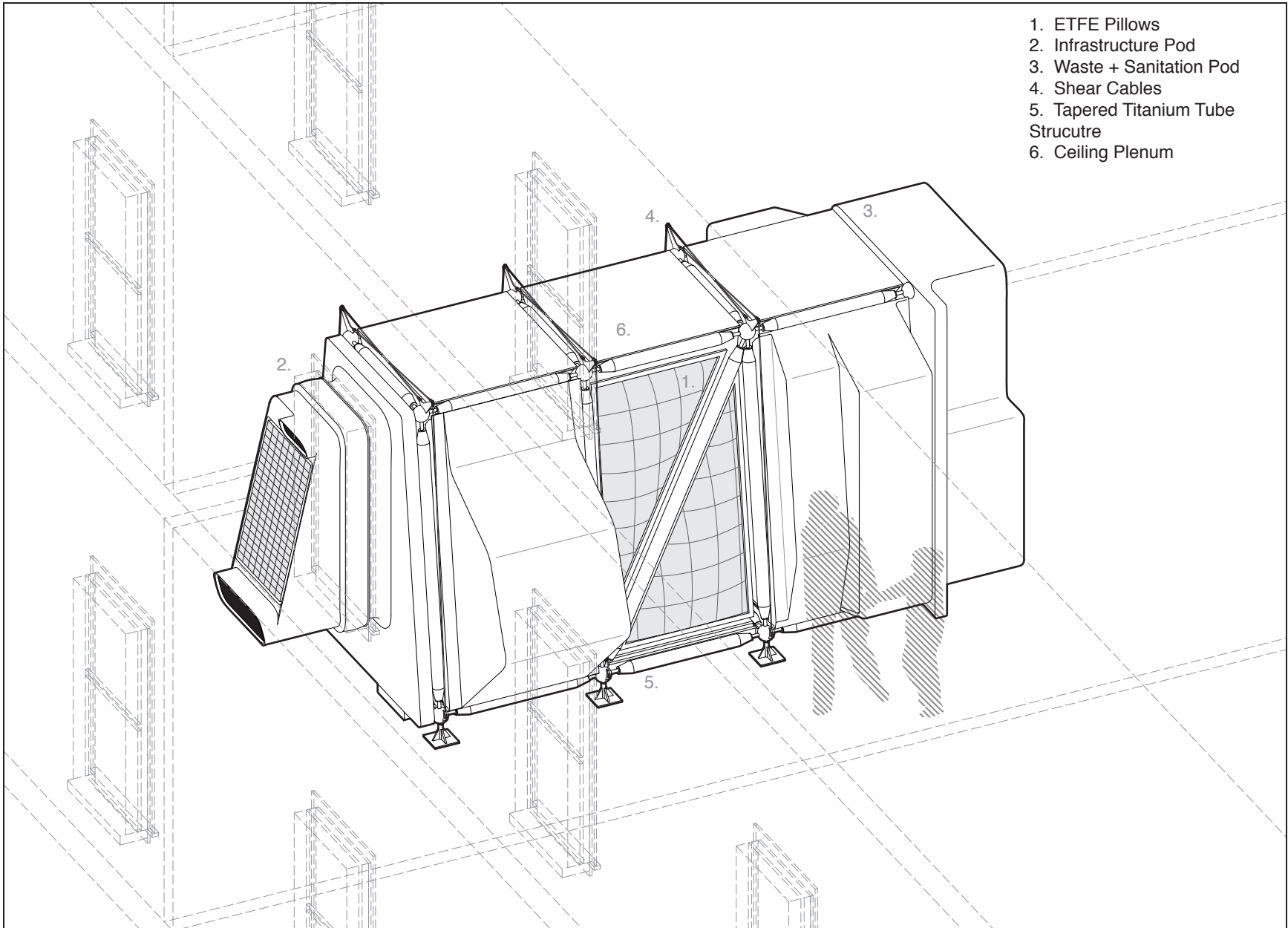

## *PROJECT DELIVERY*

Doorways, stairs and hallways are often the greatest impediments to home delivery, however building codes and conventions have generally standardized their dimensions. Contemporary hallways and doors must be able to accommodate the bulkiest consumer items such as refrigerators, sofas and mattresses or else it would be impossible to furnish one's apartment.

Because this project is meant to be quickly assembled and disassembled within an apartment, it is necessary that the pod be broken into components that are smaller than these home furnishings, ensuring that it can be deployed to virtually any home or apartment.

In addition the project must conform to maximum overall size parameters, in this case driven by the

dimensions of a typical, perhaps generous Boston apartment. This typical apartment in a masonry and wood building has a floor to ceiling height of approximately 9'-6" and a living room of around 200 sqf. with punched opening windows measuring around 3'-0 X 6'-0". These dimensions are taken as the most restrictive, ensuring that the project will be able to be installed in many other apartments with more generous dimensions.

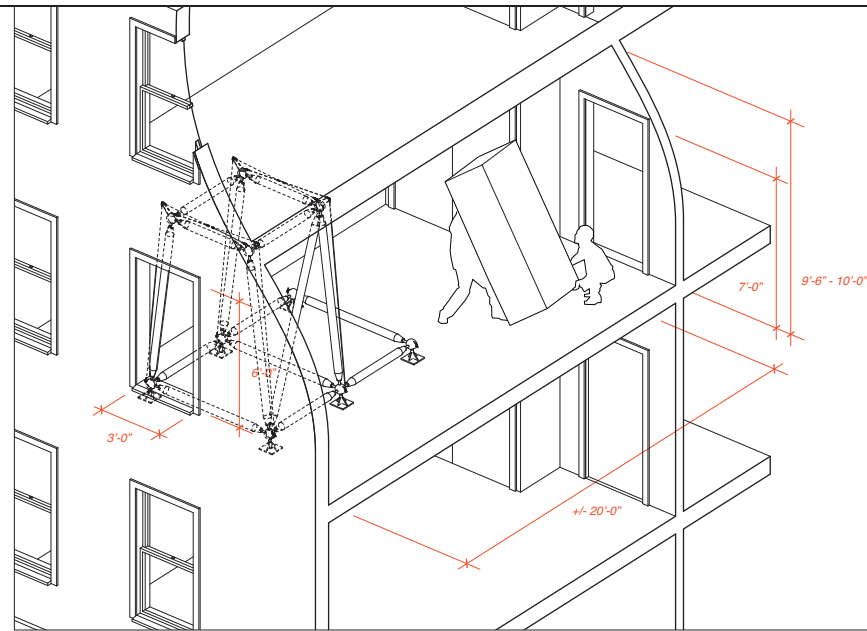
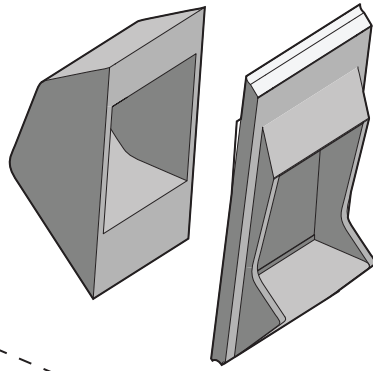
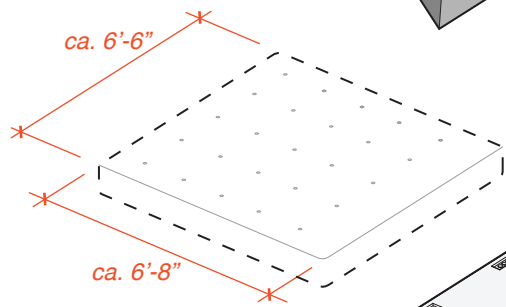
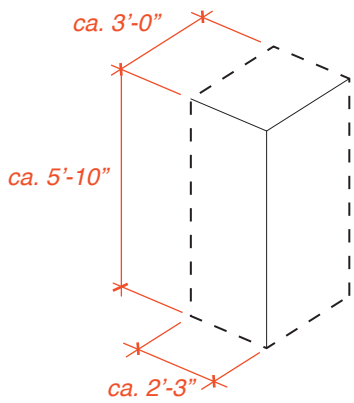

1. Floor and ceiling plena
2. Service pod
3. Ete pillow and frame
4. Structural tubes
5. Sealing pole caps
6. Plenum connectors
7. Structural base
8. Omni-directional nodes
9. Cable and turnbuckles

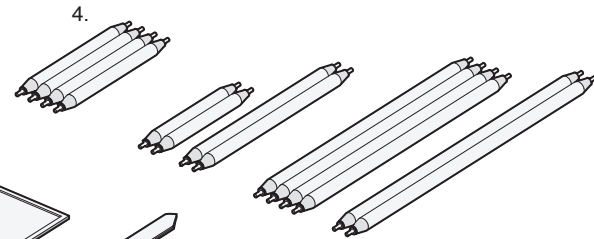
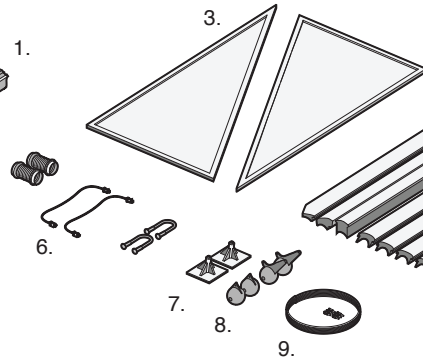
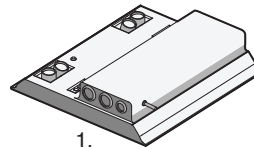
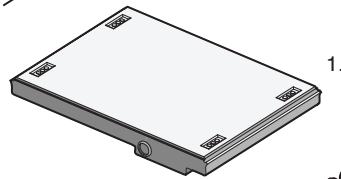

## *INFRASTRUCTURE ELEMENTS*

While there is the appearance of several disengaged systems at work in this project, in reality many of the systems are interdependent. Much like automotive dashboards, each pod is simultaneously structure and infrastructure. The carbon fiber pods provide habitable space and contain program as well as provide shear resistance within the structural system. The pods are composed of two layers of carbon fiber separated by a gap, which serves as the primary chase space for services and insulation. An extruded section of carbon fiber attached by structural webbing creates chambers in the floor and ceiling through which run the low pressure air to inflate the ETFE pillows, the HVAC supply and return, bathroom ventilation as well as conduit for the electrical system.

*CEILING SYSTEM*

- 1. Electrical Connection
- 2. Lighting
- 3. Filtered Air Supply
- 4. Bathroom Vent Return
- 5. ETFE Inflation Air Source and Hose
- 6. Flexible Duct Connection

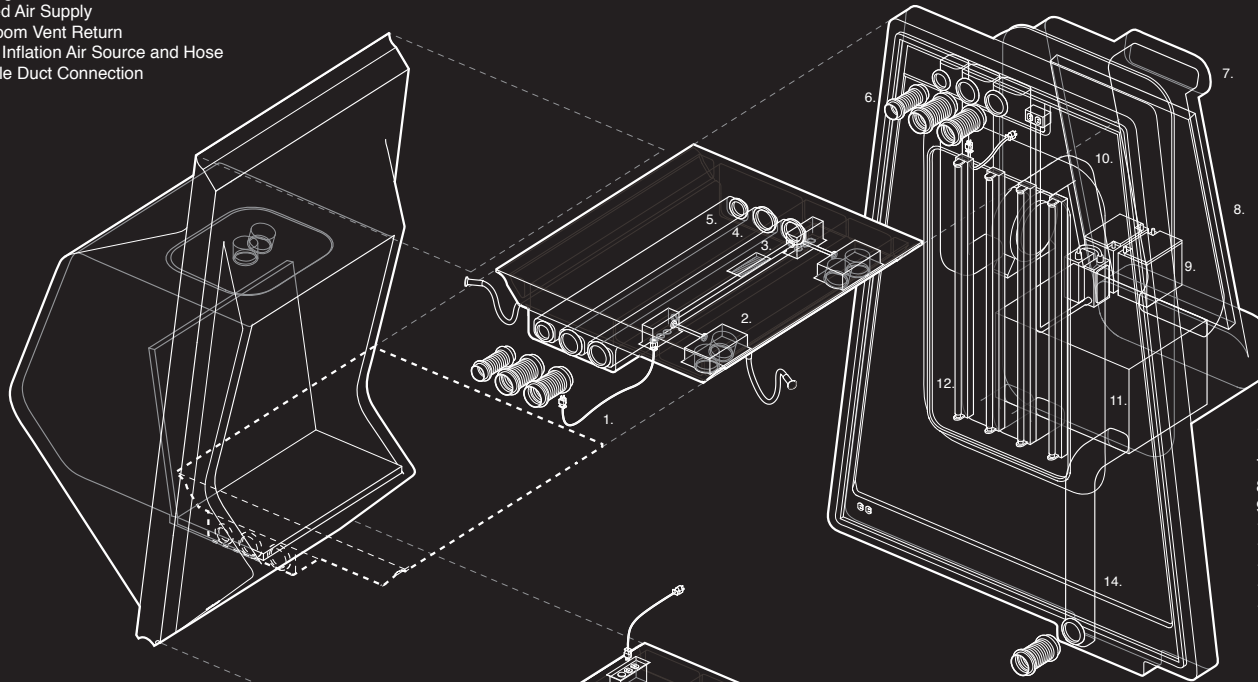

*INFRASTRUCTURE UNIT*

- 7. Air Exhaust
- 8. Photo Voltaic Panel
- 9. Electrical Inverter and Batteries
- 10. Low-Pressure Air Supply
- 11. Hvac and Air Filtration System
- 12. Full-Spectrum Light Replacement Lamps
- 13. Air Intake
- 14. Air Return

*FLOOR SYSTEM*

- 15. Electrical Connection
- 16. Return Air Duct within Plenum Structure
- 17. Flexible Duct Connection
- 18. Additional Units

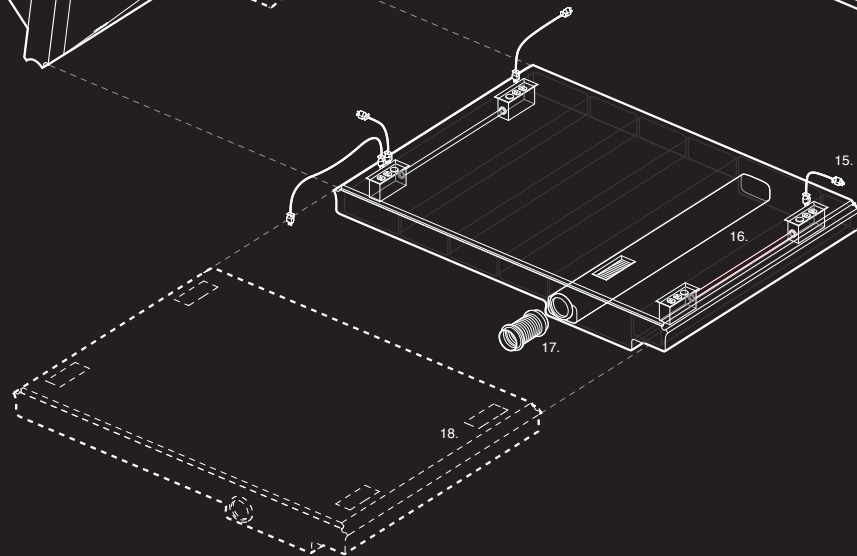

## *STRUCTURAL SCHEMATIC*

The dominant structural system in this project is a three dimensional space frame composed of tubular titanium spokes and adjustable cast metal nodes. In cross section, braided cable connected to metal flitch plates attached to the nodes prevent wracking, as well as the project's metal feet. In the longitudinal direction, tubular cross bracing provides structural stability. In certain cases, infill pods with reinforced corners act as shear panels.

As the project cantilevers out of a window or building perforation, additional compression elements extend to the ceiling to brace the entire structure. Although the project is meant to be deployed surreptitiously and with minimal impact on the building, it would be possible to provide additional cable support from the roof, or to extend the structure to a nearby building, bracing against an exterior wall.

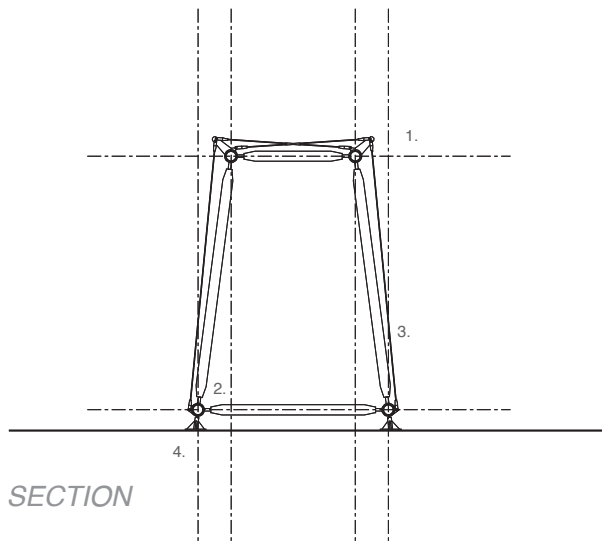
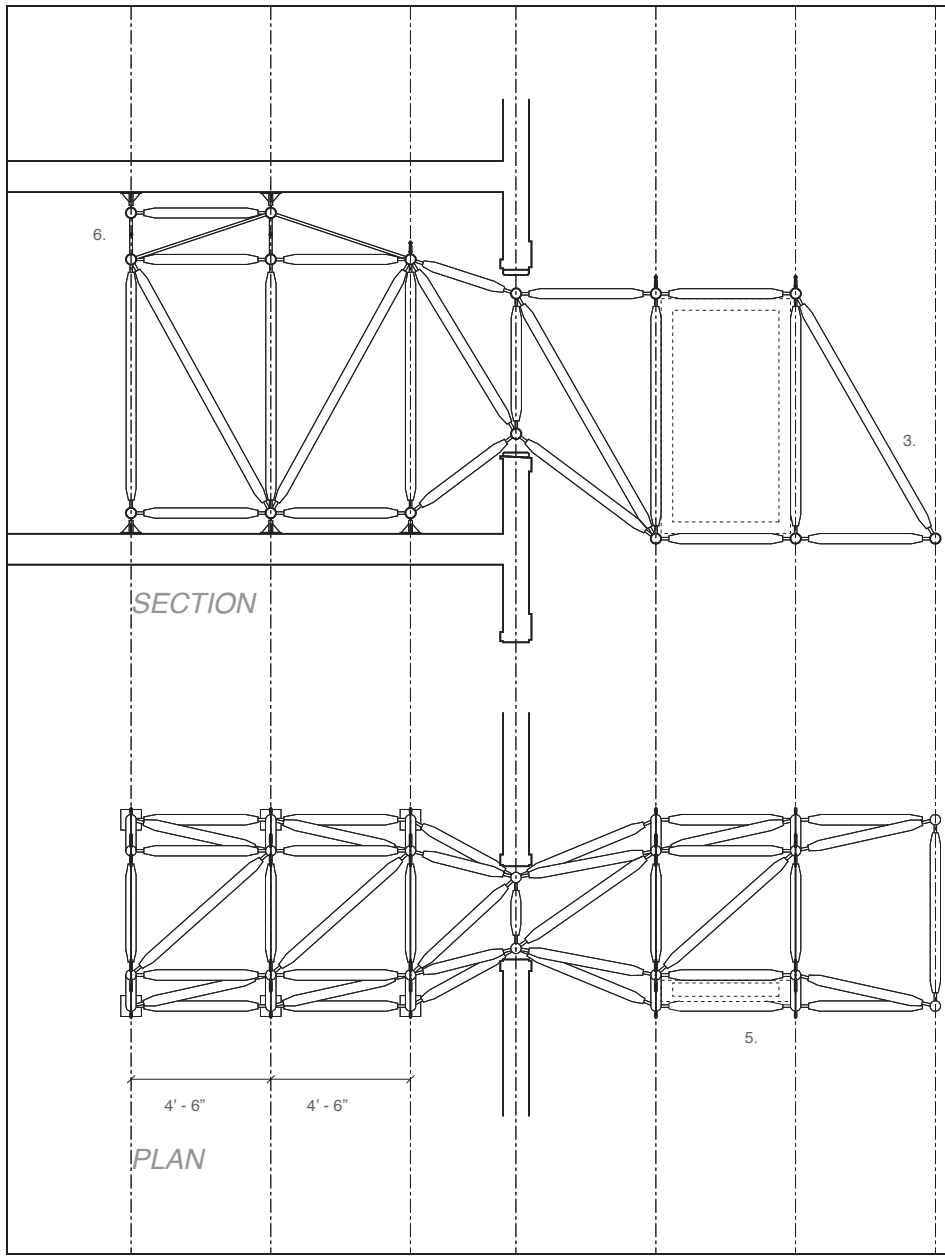

- 1. Exterior cable cross bracing
- 2. Cast metal nodes
- 3. Tapered titanium tubing
- 4. Metal feet
- 5. Pod as shear panel
- 6. Cantilever bracing

COMPONENTS

46

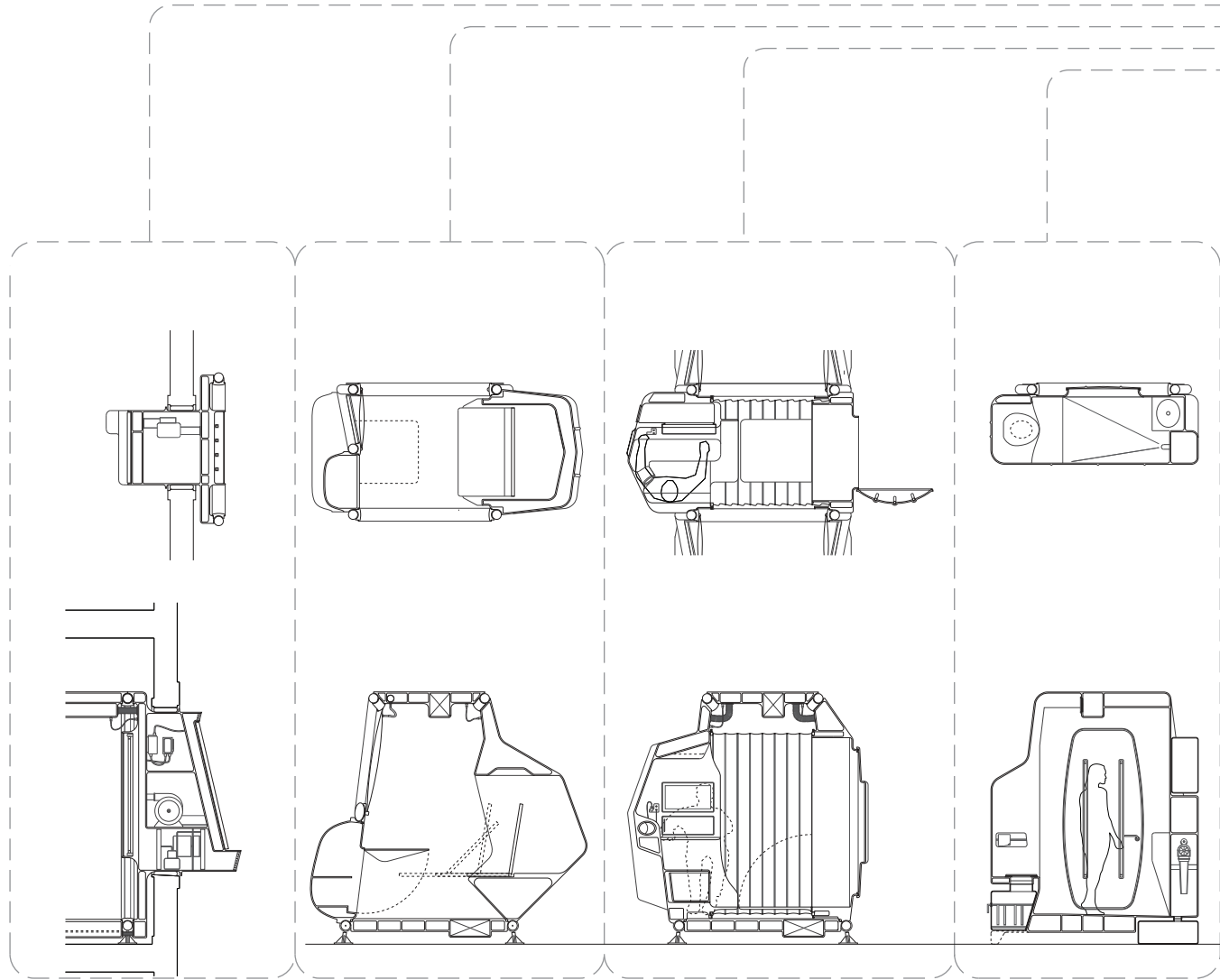

INFRASTRUCTURE POD

SLEEPING + STORAGE  
+ TABLE

COMMUNICATION + ENTRY  
+ DISINFECTION  
+ MONITORING

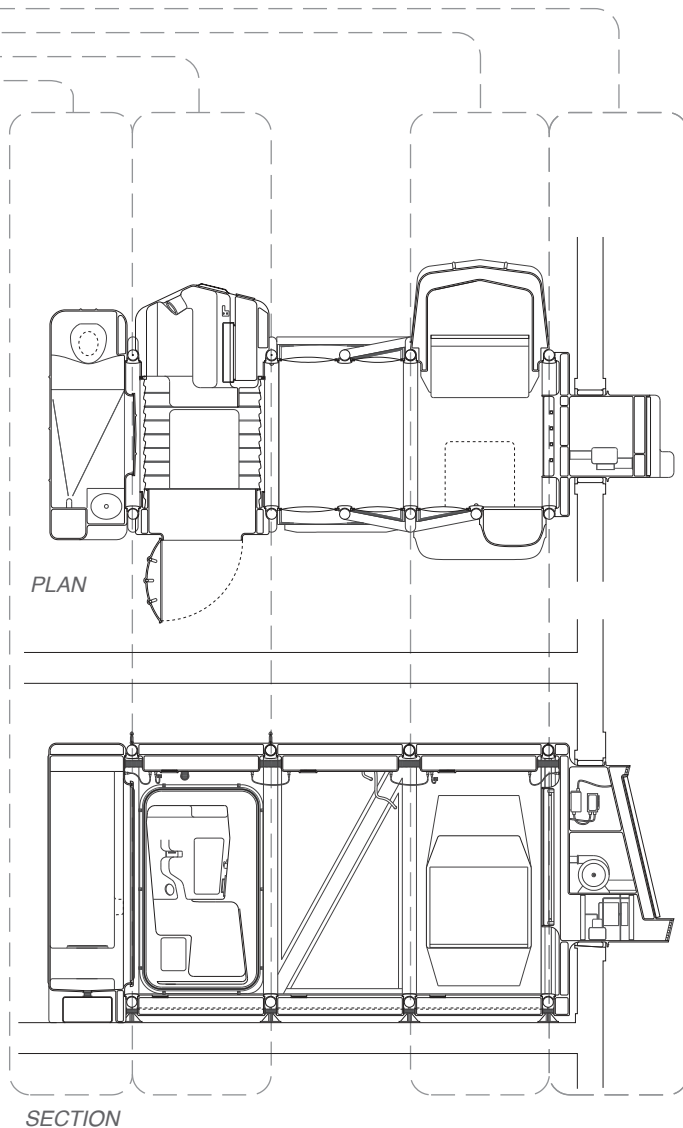

## CORE CONFIGURATION

The core unit is designed for an individual living at home with at least one other family member or caretaker. It accommodates one healthy individual for up to three weeks, while the threat of pandemic harmlessly passes by.

While the pod is fundamentally limited by the necessity of a caretaker to provide food and company, the situation where there is a disparity in prophylaxis within a single household is real and relevant. Every flu pandemic has affected particular segments of society most. While it is often children, the elderly and the infirm, the familiar 'W' curve of the 1918 flu reveals how other more robust demographics may be susceptible to a particular flu strain. In addition, deaths from Hospital-Acquired Infections and secondary infections skew the actual number of flu deaths, which leaves the home as one of the last resorts for someone escaping the pandemic.

Although the unit is designed for invacuation, it could be imagined that in certain situations, it could serve effectively as in-house quarantine unit. Depending on the pervasiveness of the pandemic, there might exist a moment when the number of sick out number the healthy by a margin that calls into question the idea of invacuation, and quarantine might become the dominant method of containing the disease.

COMPONENTS

48

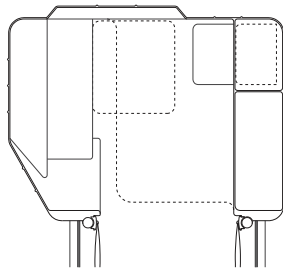

SLEEPING + SOCIALIZING

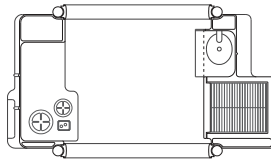

FOOD PREPARATION +  
STORAGE

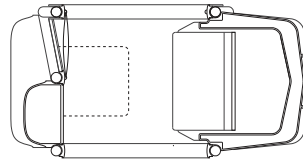

SLEEPING + STORAGE  
+ TABLE

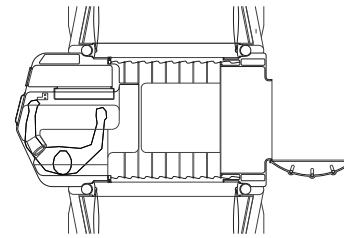

COMMUNICATION + ENTRY  
+ DISINFECTION  
+ MONITORING

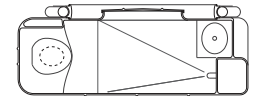

WASTE + SANITATION

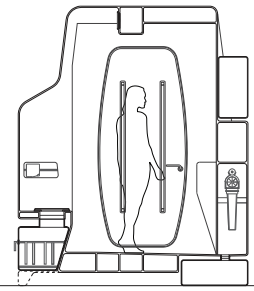
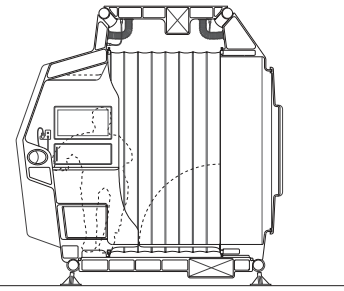
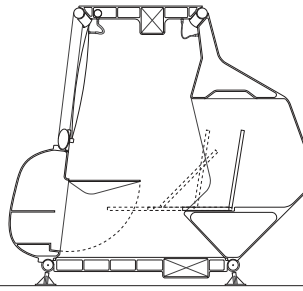
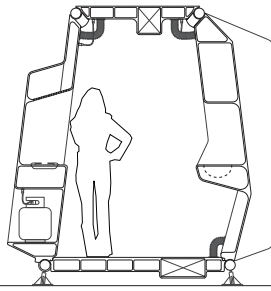
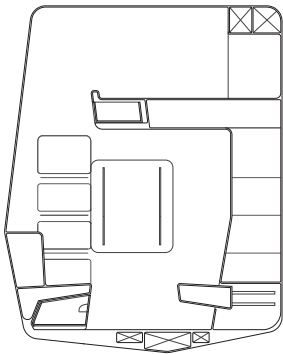

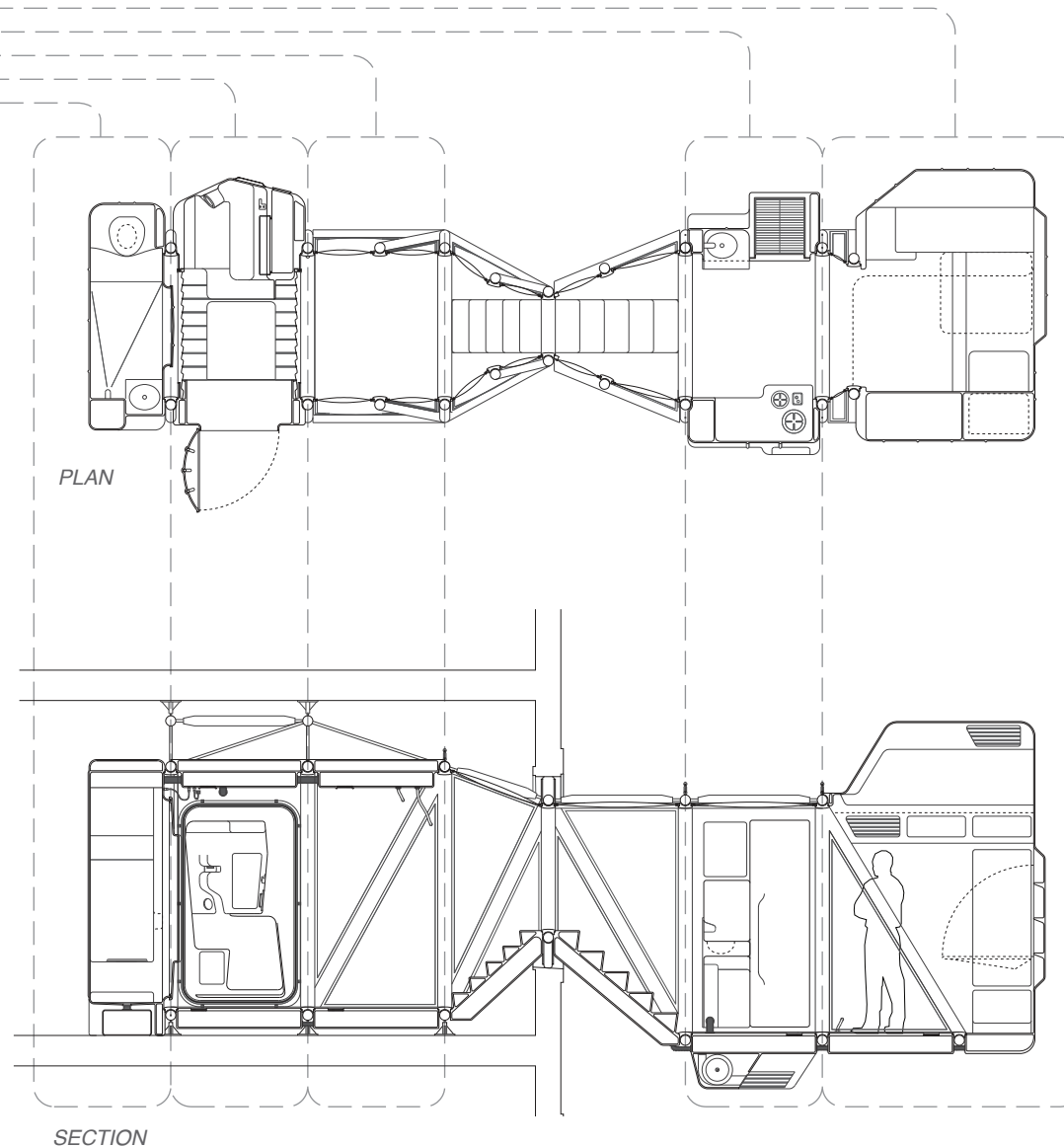

## EXPANDED CONFIGURATION

In the case where two or more people require invacuation, the unit can be expanded with pods that fulfill more diversified programs, including food preparation, expanded living quarters, and entertainment. While these pods can maintain a certain level of independence, they are still limited by the requirements of food and supplies, though one would only need to occupy the pod for a matter of weeks.

Because of the potential encumbrance created by the addition of a pod to an apartment to the residents outside of the pod, the unit can cantilever outward from a typical window using the floor and ceiling as bracing. Because the units are made from carbon fiber and most of the heaviest programmatic pods remain inside the building, a modest cantilever can be achieved, which will ease the space pressures inside the apartment and provide greater visibility and light to the residents of the pod.

50

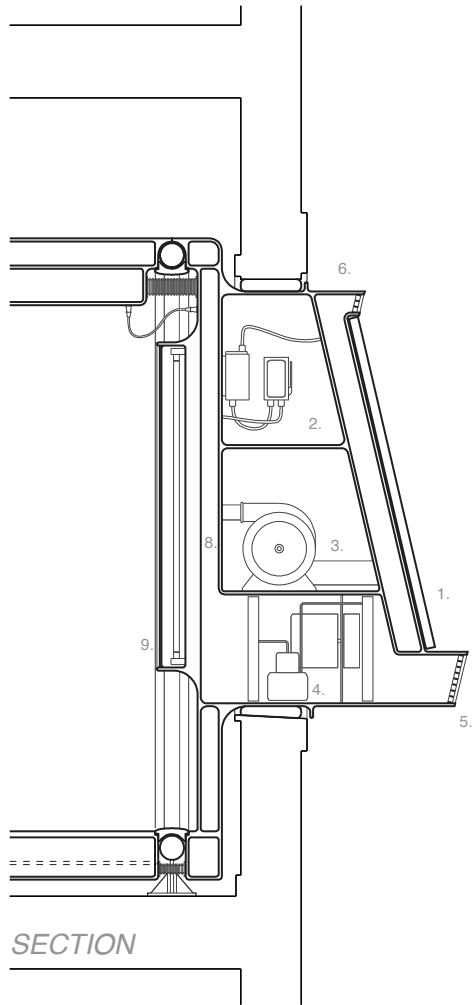

SECTION

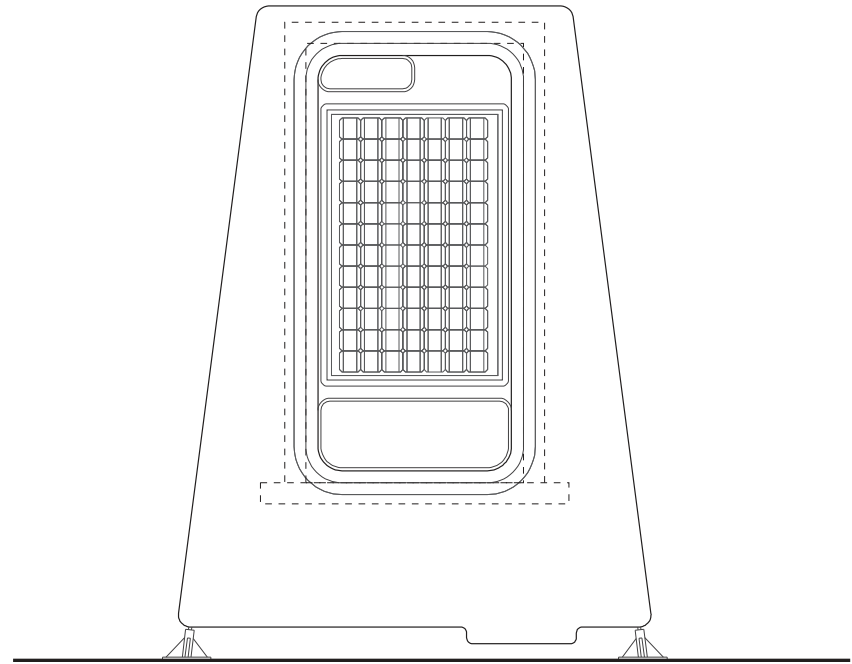

ELEVATION

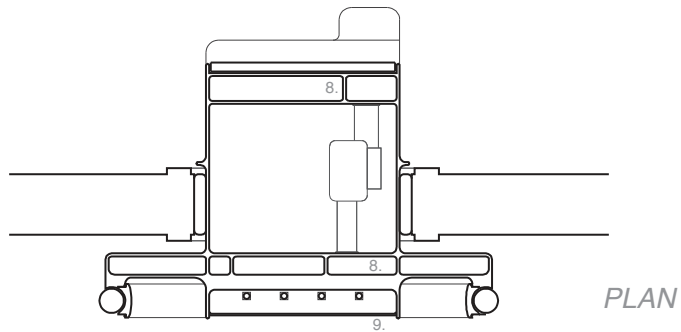

CORE ELEMENT:

## INFRASTRUCTURE

1. Photovoltaic Panel
2. Inverter and Batteries
3. Low-Pressure ETFE Inflation Pump
4. Air Purification, Air Conditioning, Heating and Ventilation
5. Intake Air Scoop
6. Exhaust Vent
7. Flexible Conduit
8. Integrated Chase Space
9. UV Daylight Simulation Bulbs

SCALE:  
 $\frac{3}{8}'' = 1'-0''$  0 1 5

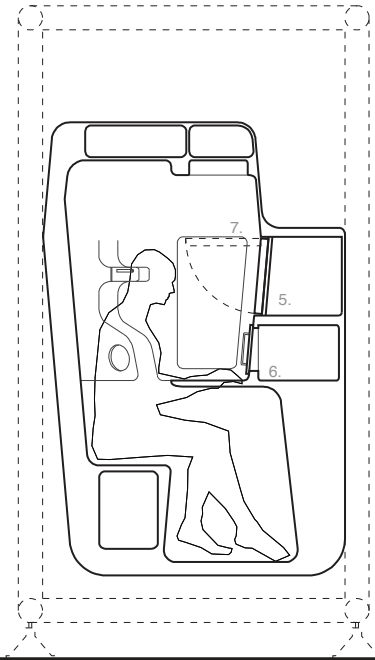

SECTION

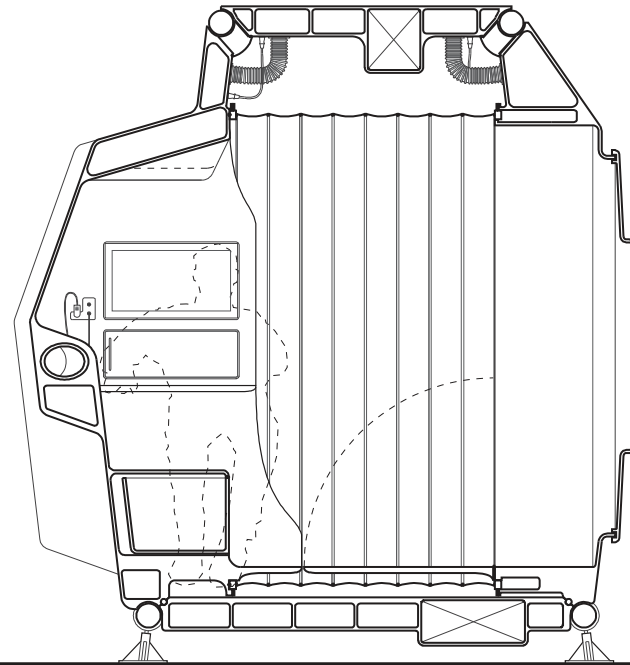

SECTION

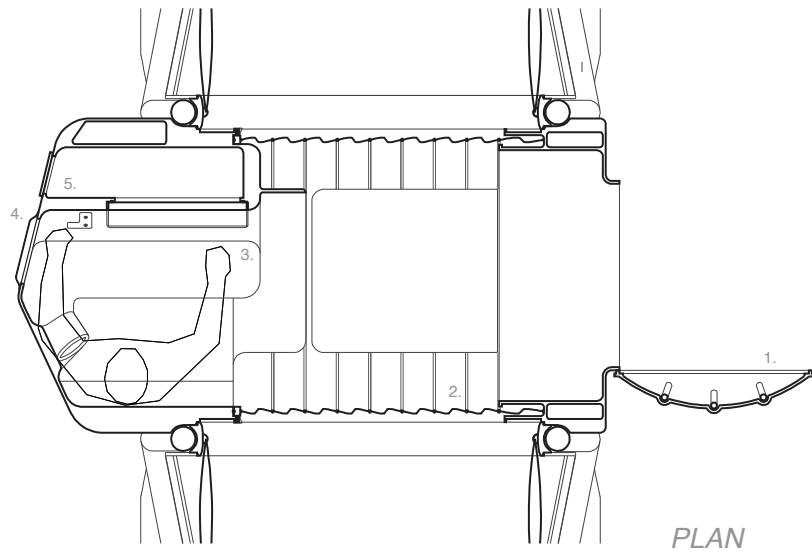

CORE ELEMENT:

*COMMUNICATION +  
ENTRY + DISINFEC-  
TION + MONITORING*

1. Entry Door with UV Disinfection Lamps
2. Expandable Membrane Enclosure
3. Health Monitoring Station
4. Window Partition
5. Transfer Compartment
6. Refrigerated Specimen Container
7. Heads-Up Display

SCALE:  
3/8" = 1'-0" 0 1 5

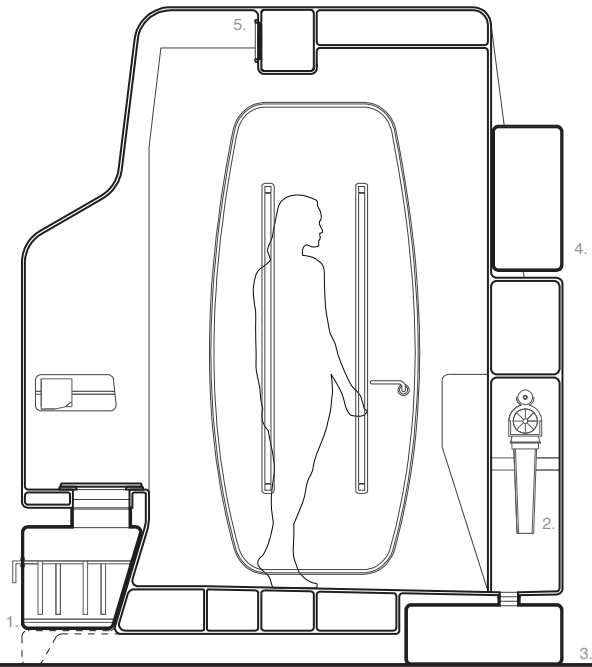

SECTION

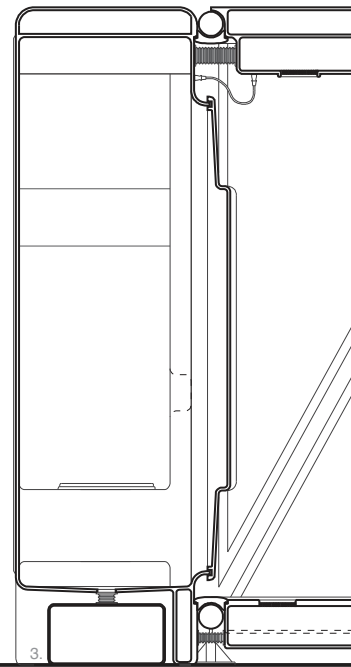

SECTION

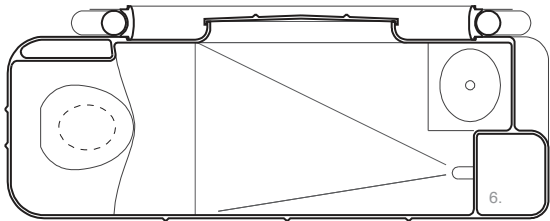

PLAN

CORE ELEMENT:

## WASTE + SANITATION

1. Detachable Composting Toilet
2. Water Filtration System
3. Greywater Storage
4. Freshwater Storage
5. Ventilation Duct
6. Water Chase

SCALE:  
3/8" = 1'-0" 0 1 5

56

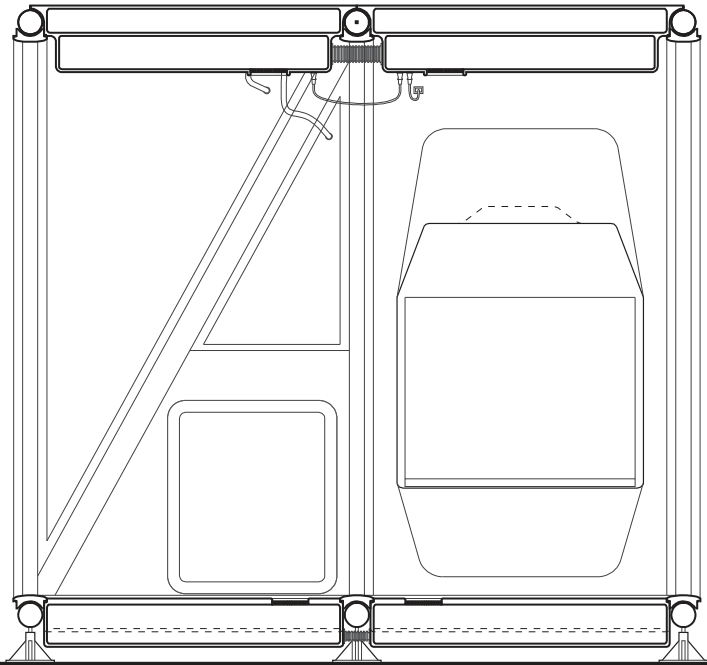

SECTION

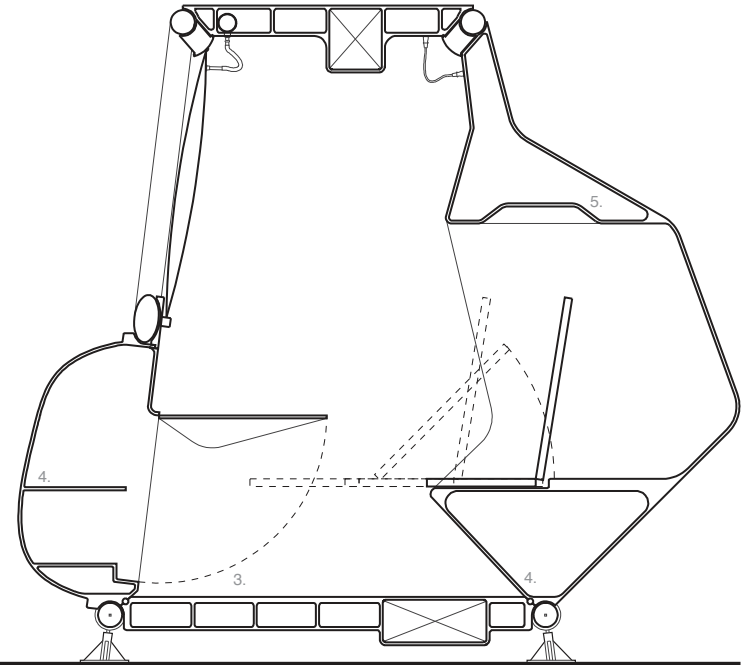

SECTION

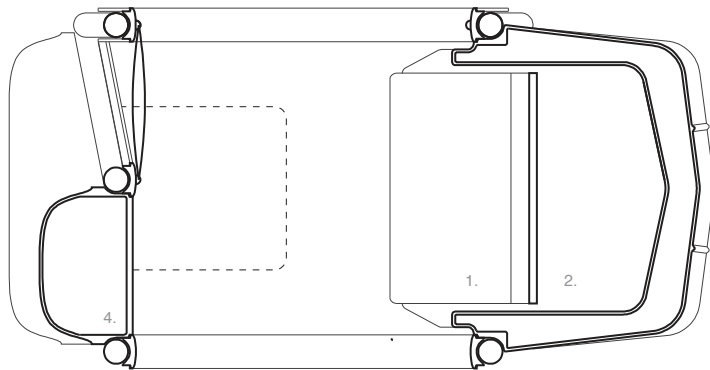

PLAN

CORE ELEMENT:

## SLEEPING + STORAGE + TABLE

1. Sleeping/Sitting unit
2. Bedding Storage
3. Swing-out Table
4. Storage
5. Lighting/Ventilation Control

SCALE:  
3/8" = 1'-0" 0 1 5

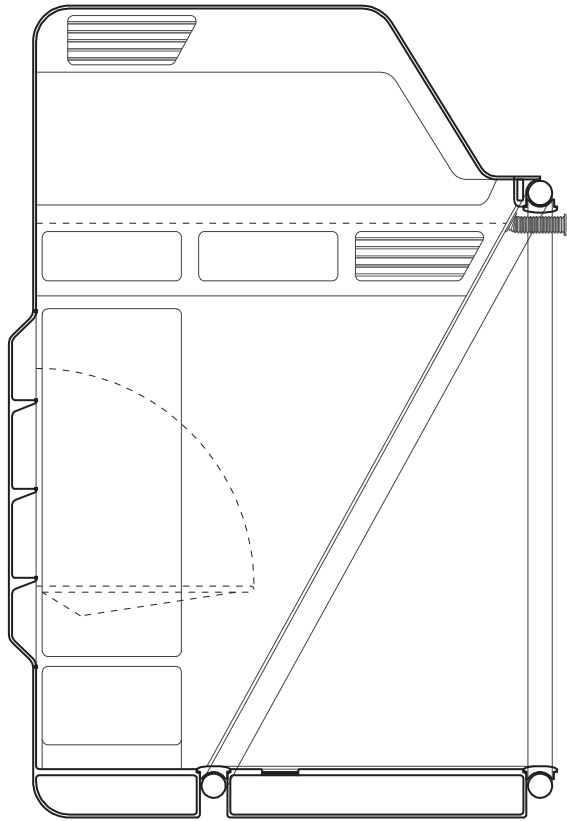

SECTION

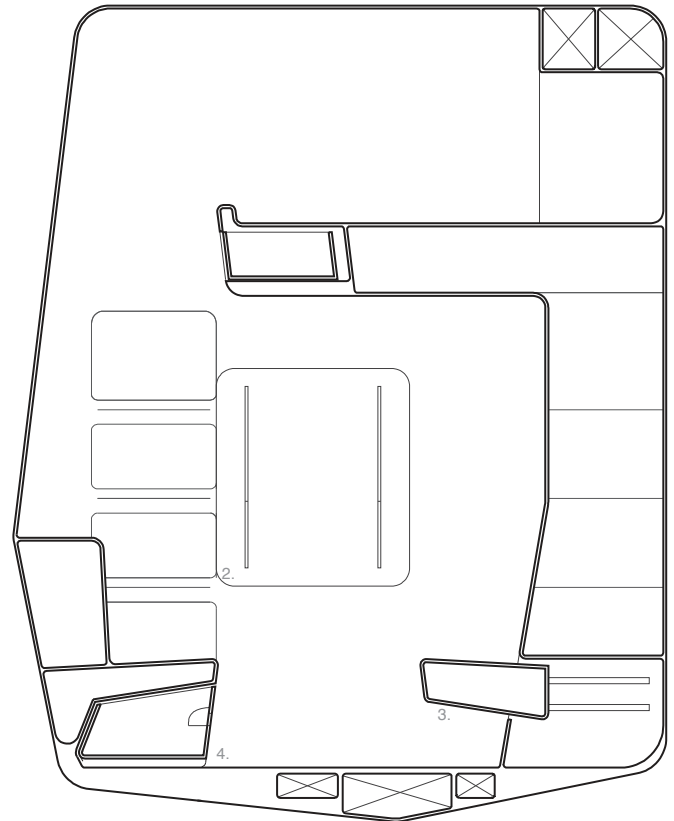

SECTION

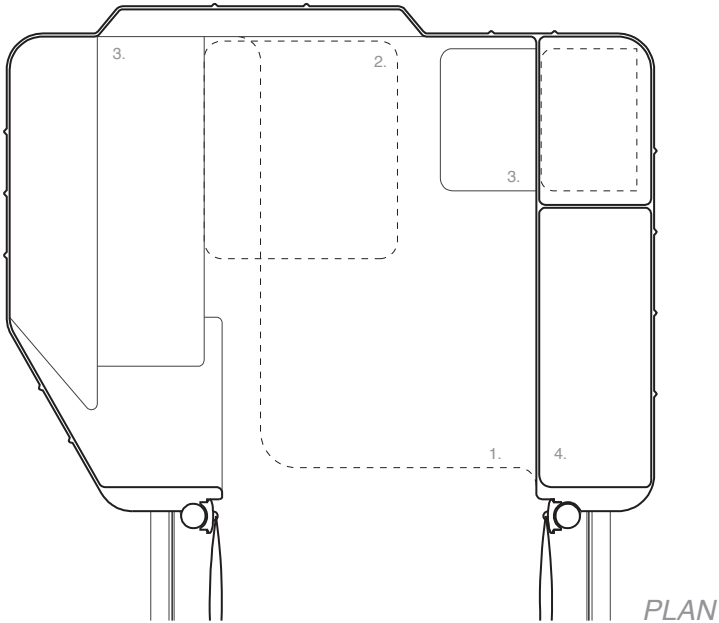

EXPANSION UNIT:  
**SLEEPING + SOCIALIZING**

- 1. Bed Above
- 2. Fold-Down Table
- 3. Expandable Seating
- 4. Storage
- 5. Ladder

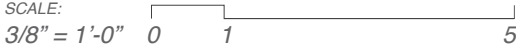

60

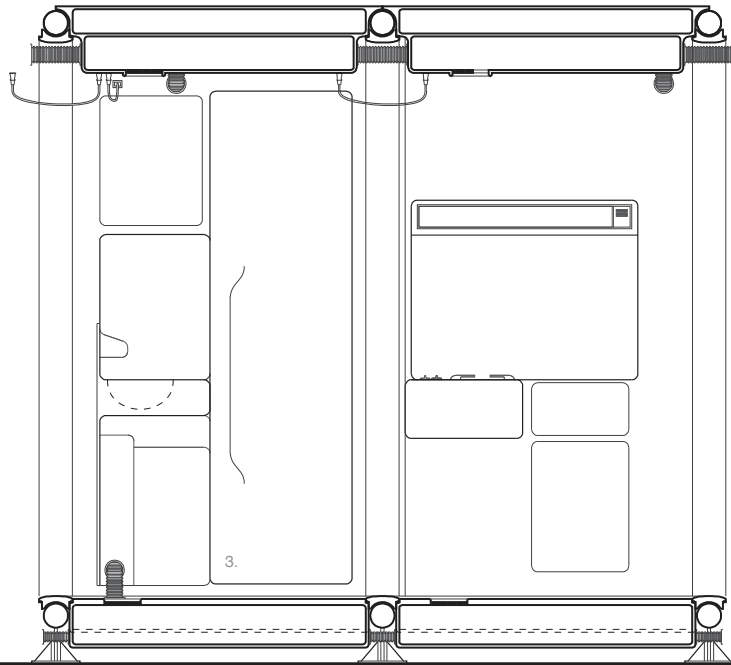

SECTION

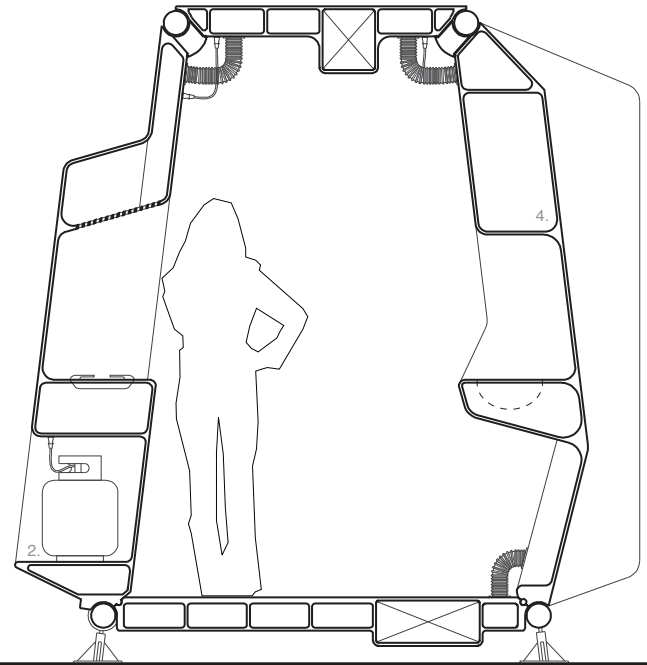

SECTION

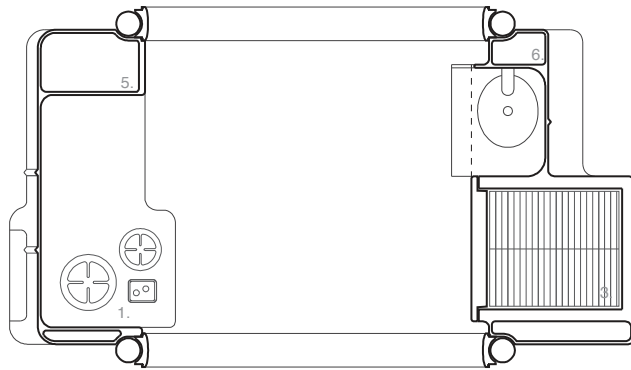

PLAN

EXPANSION UNIT:

*FOOD PREPARATION  
+ STORAGE*

1. Gas Stove
2. Tank Storage
3. Refrigerator
4. Storage Units
5. Ventilation Chase
6. Water Chase

SCALE:  
 $\frac{3}{8}'' = 1'-0''$  0 1 5

62

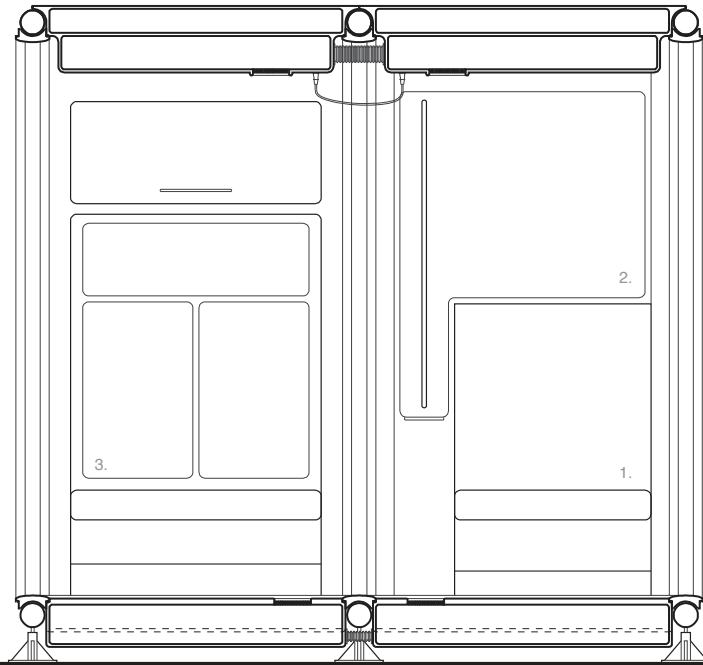

SECTION

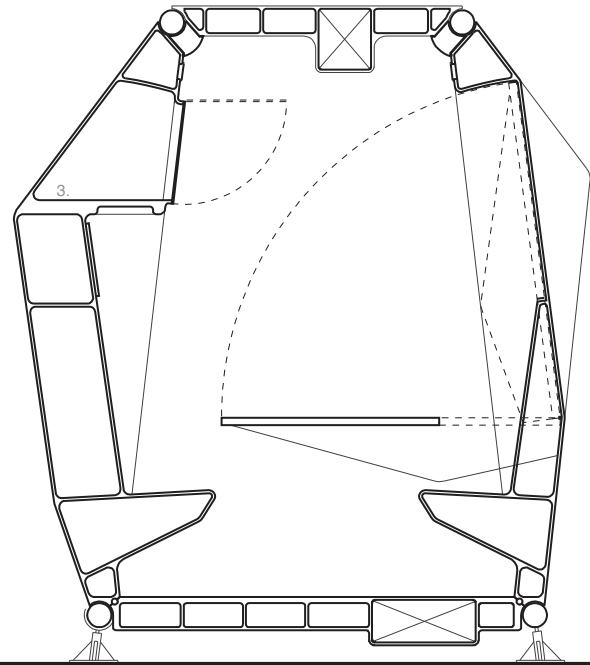

SECTION

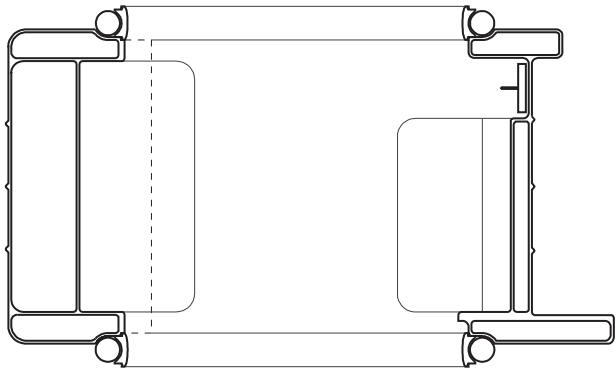

PLAN

EXPANSION UNIT:

# SEATING + STORAGE

- 1. Seating
- 2. Fold-Down Table
- 3. Storage

SCALE:  
3/8" = 1'-0" 0 1 5

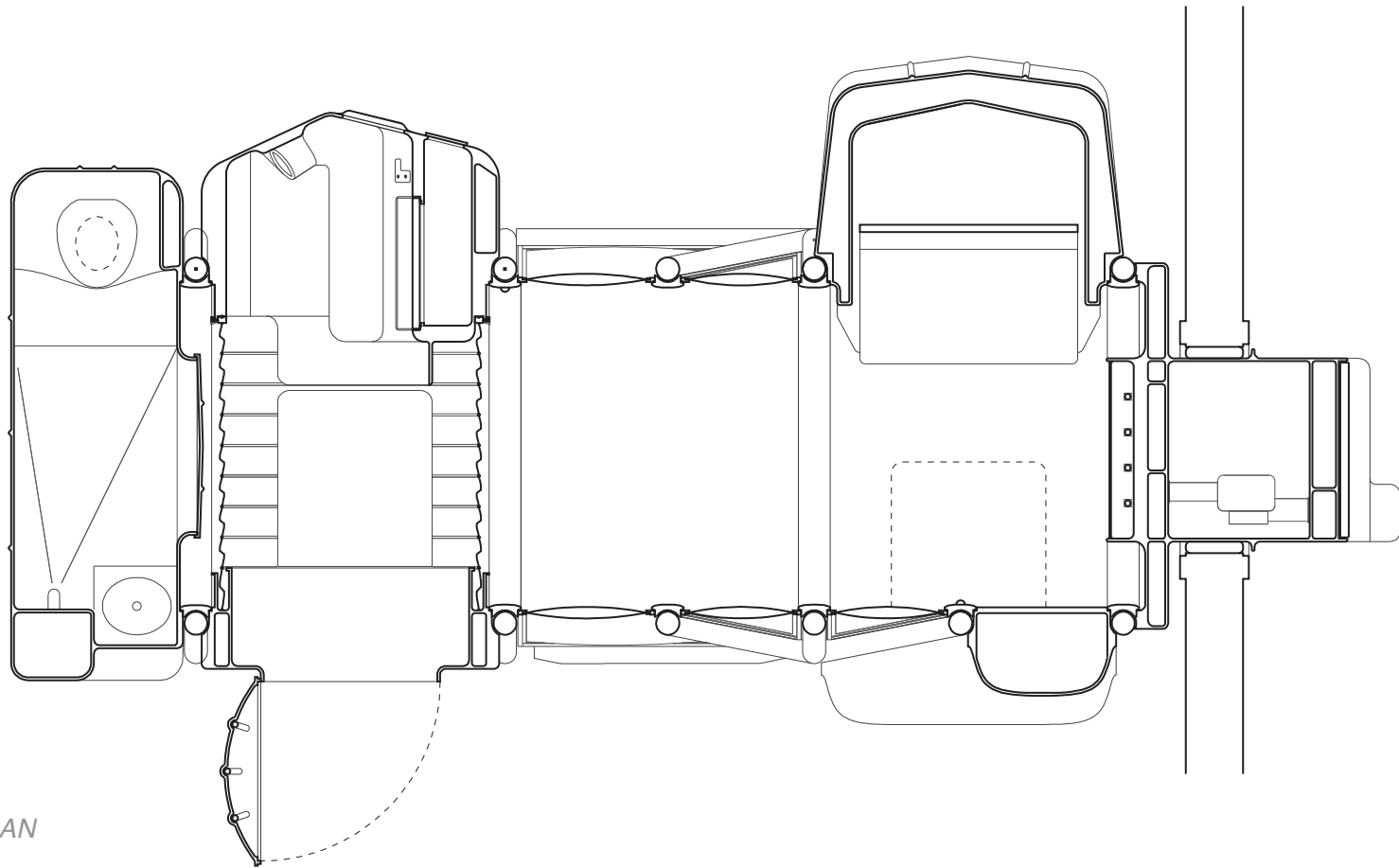

PLAN

**CORE CONFIGURATION**

SCALE: 3/8" = 1'-0" 0 1 5

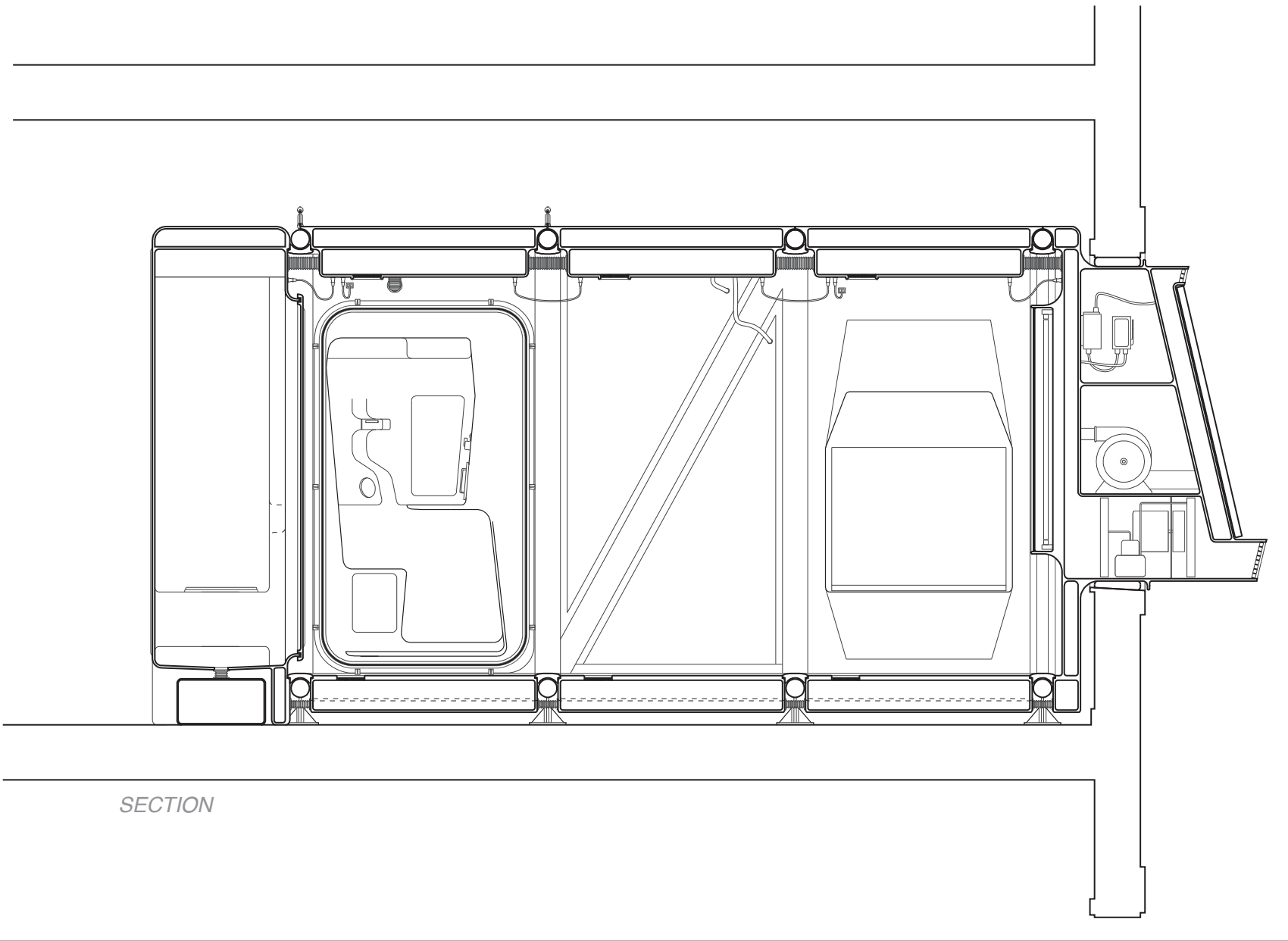

SECTION

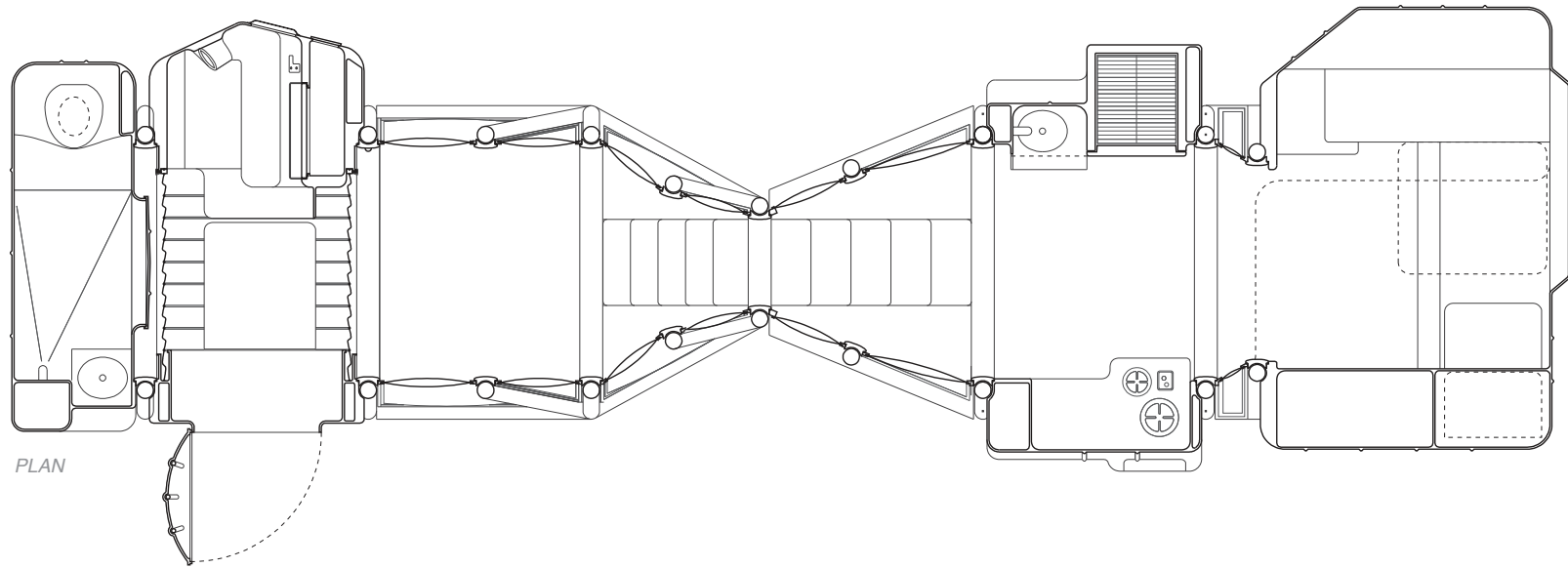

PLAN

**EXPANDED CONFIGURATION**

SCALE:

$3/8" = 1'-0"$



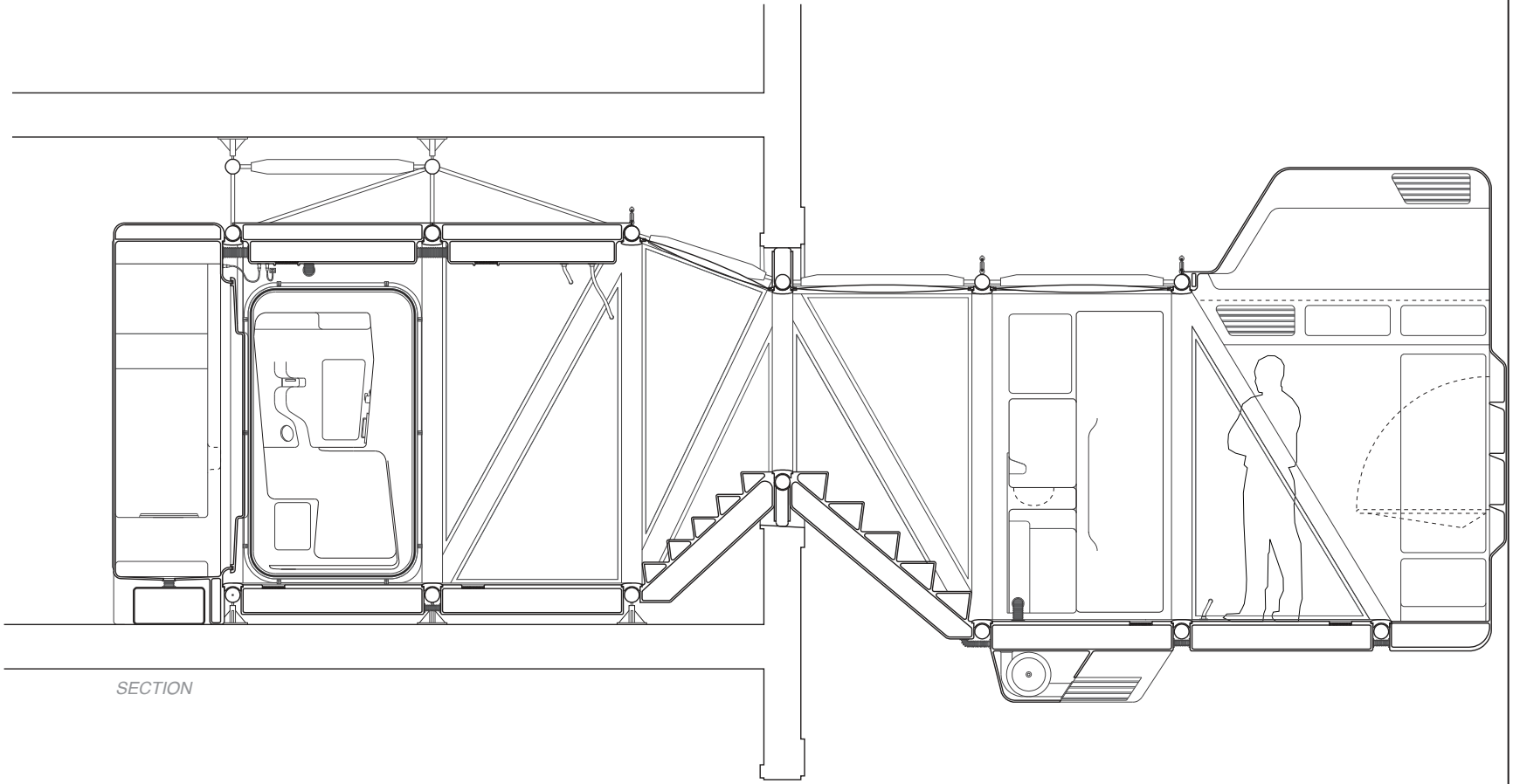

SECTION

68



*Final Model*

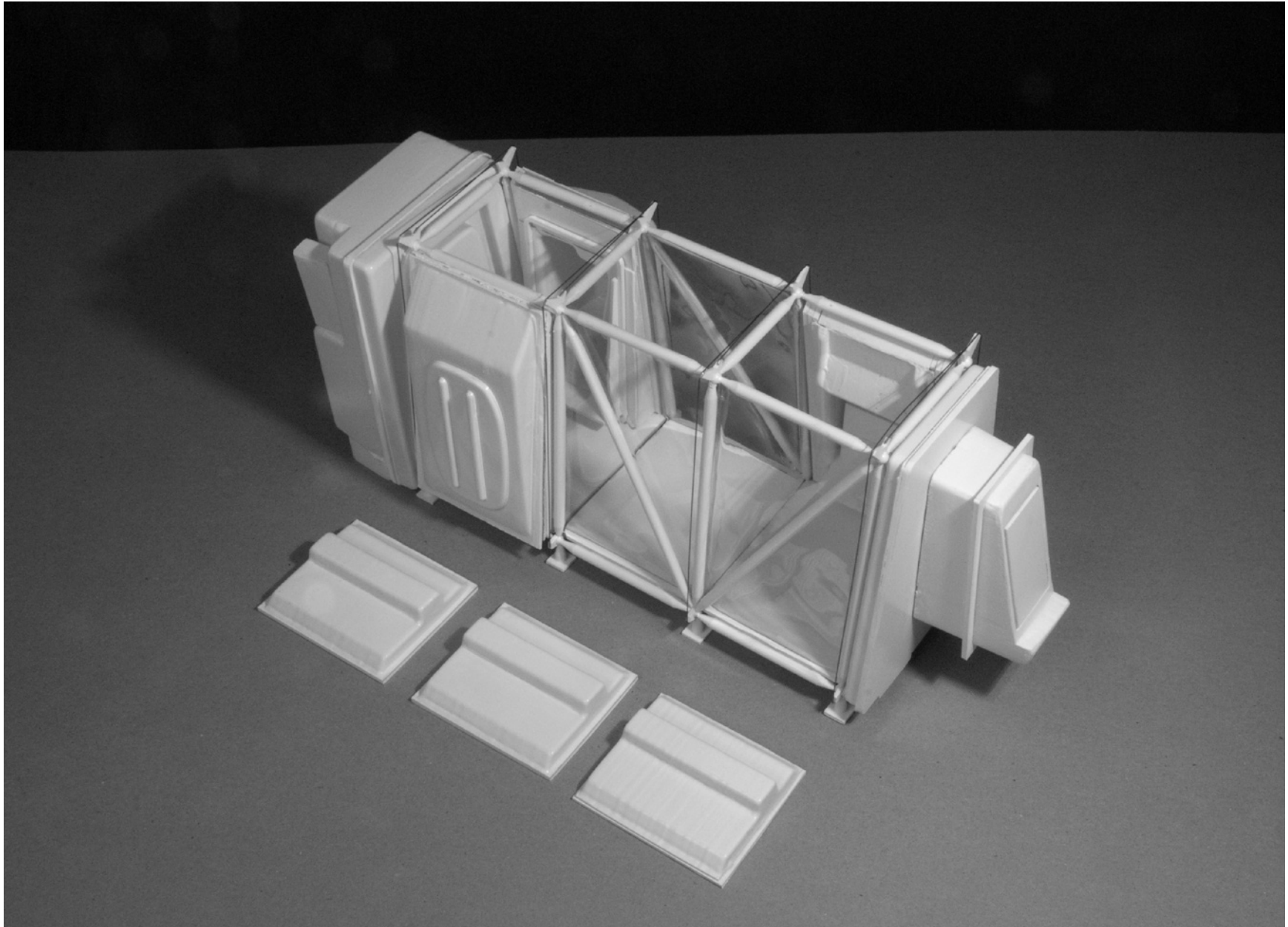

70

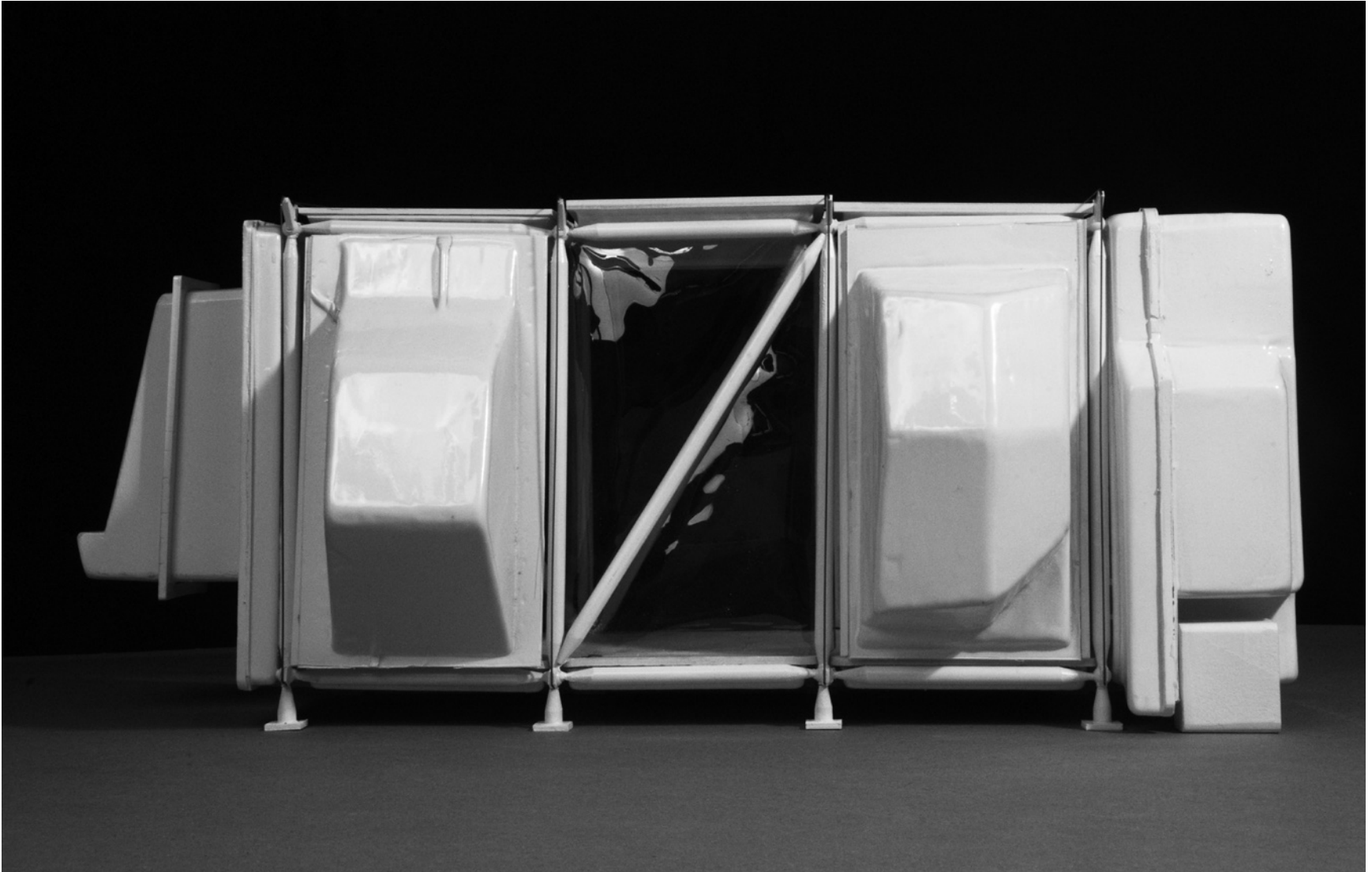

*Final Model*

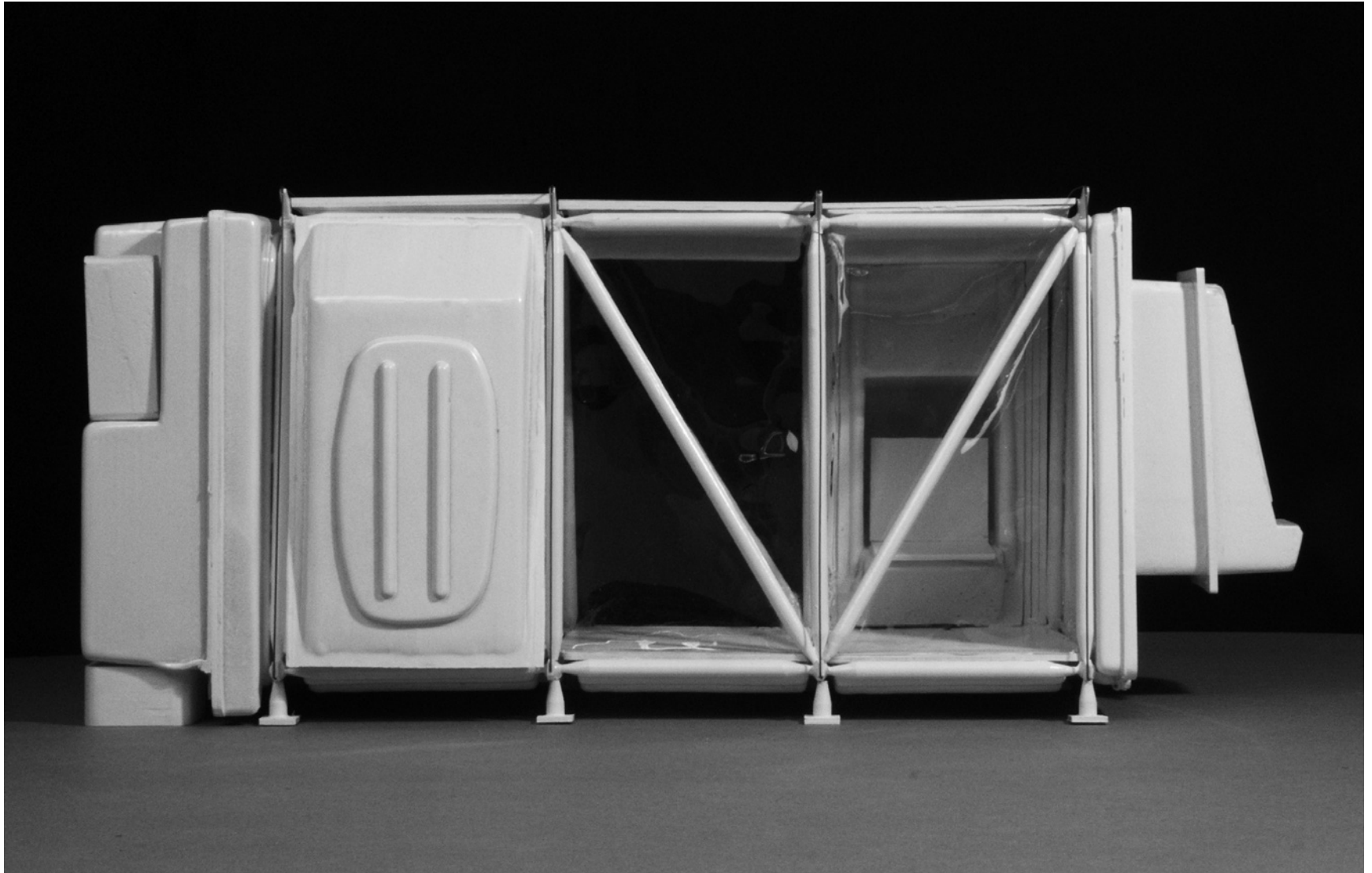

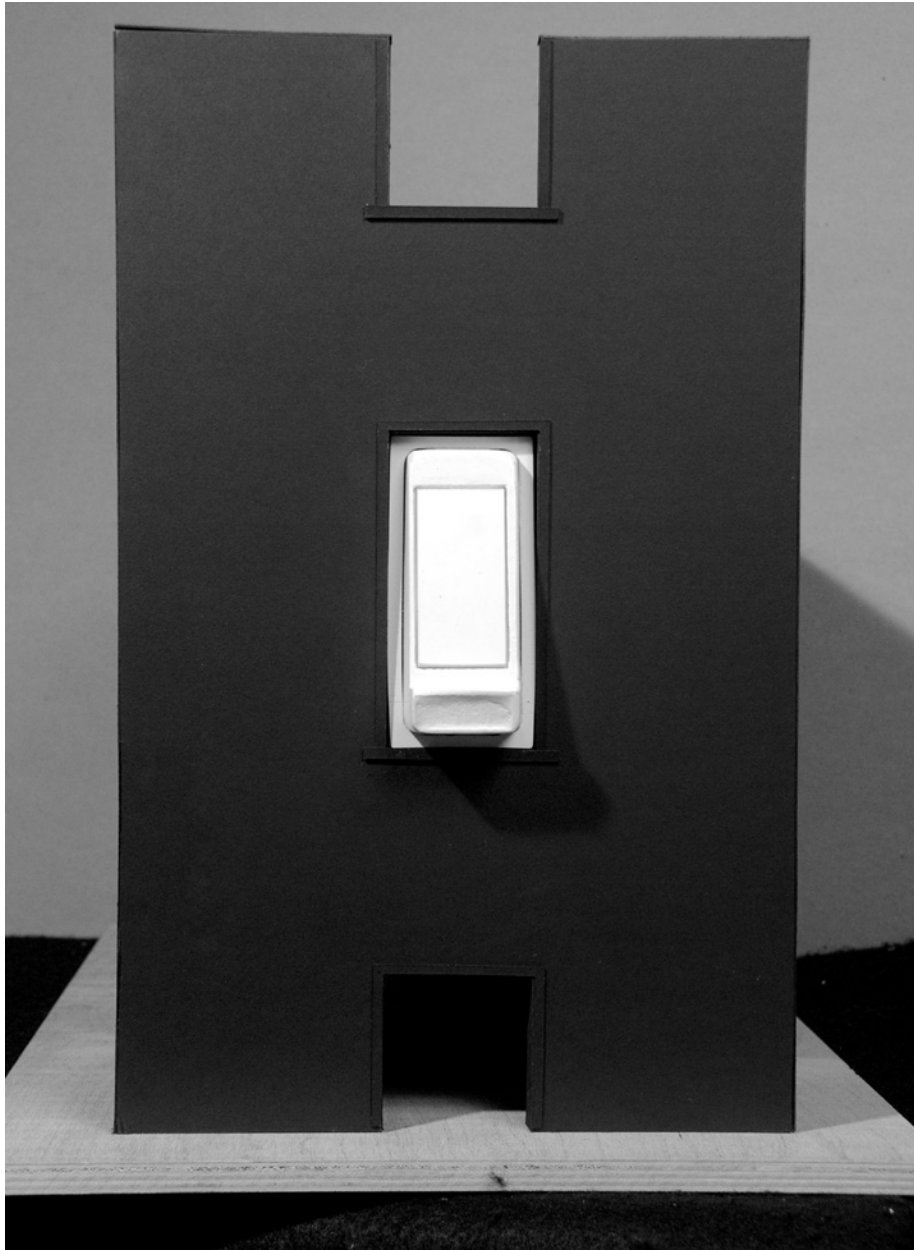

*Final Model*

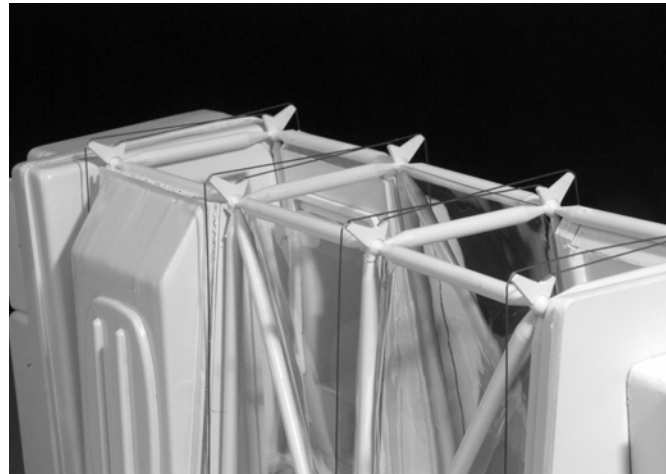
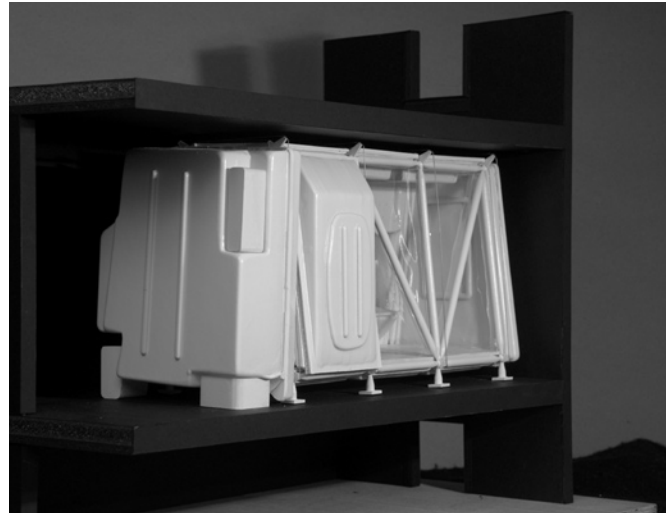

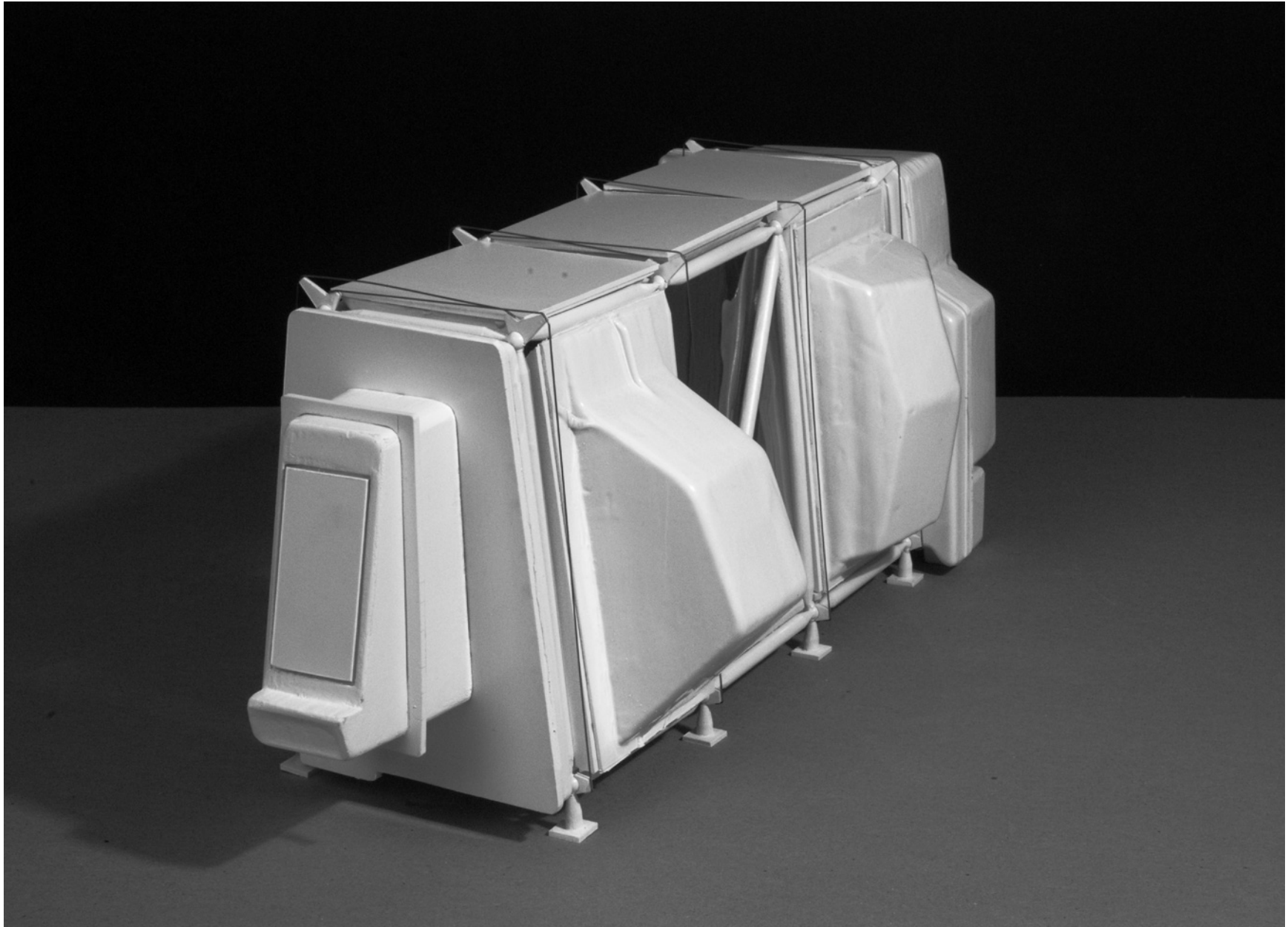



*In Situ Rendering*



## *THE EMERGENCE OF PANDEMIC URBANISM*

As the number of cases increase, and hospital beds become scarce during a pandemic, the prevalence of the invacuation pod within the space of the city has the potential to create an entirely new urban condition. Much like masks worn in public, or the ringing of the leper's bell, these interventions become a manifestation of the anxiety that has plagued the city since its inception. How does one balance the need for interaction and commerce with personal protection? When does this balance tip in favor of one versus the other. In this regard, the Model State Emergency Health Powers Act is an important lens through which to view this paradox through government policy. While expanding the powers of the government in time of duress may be more effective in quashing communicable diseases, it violates the essence of the social contract. This project

seeks a similar compromise, providing protection, but making certain concessions in order to engage with the city itself. While one may have invacuated oneself into a pod, its expansion beyond the building envelope engages the space that facilitates the transmission of the disease, simultaneously being more secure and more exposed as well as acting as a barometer of the health of the citizens.





4

*Previous Incarnations*





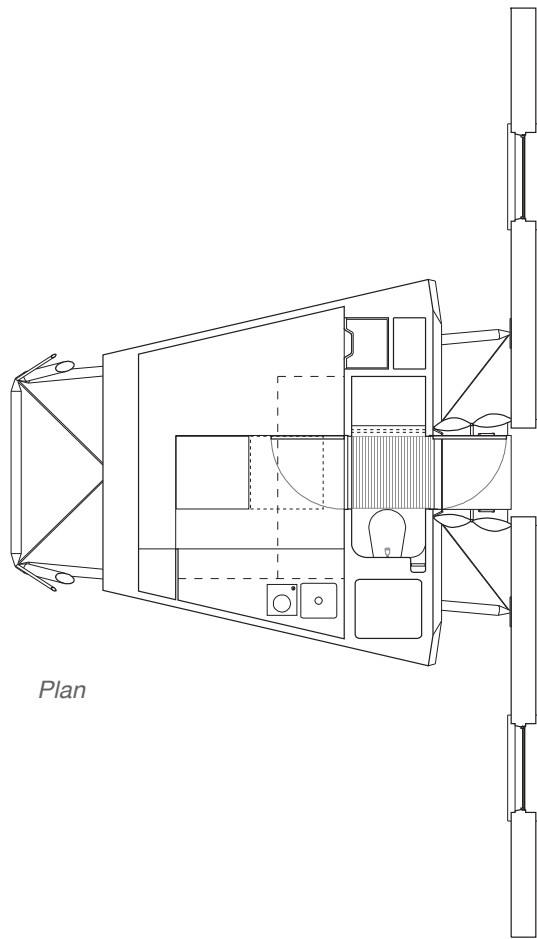

Plan

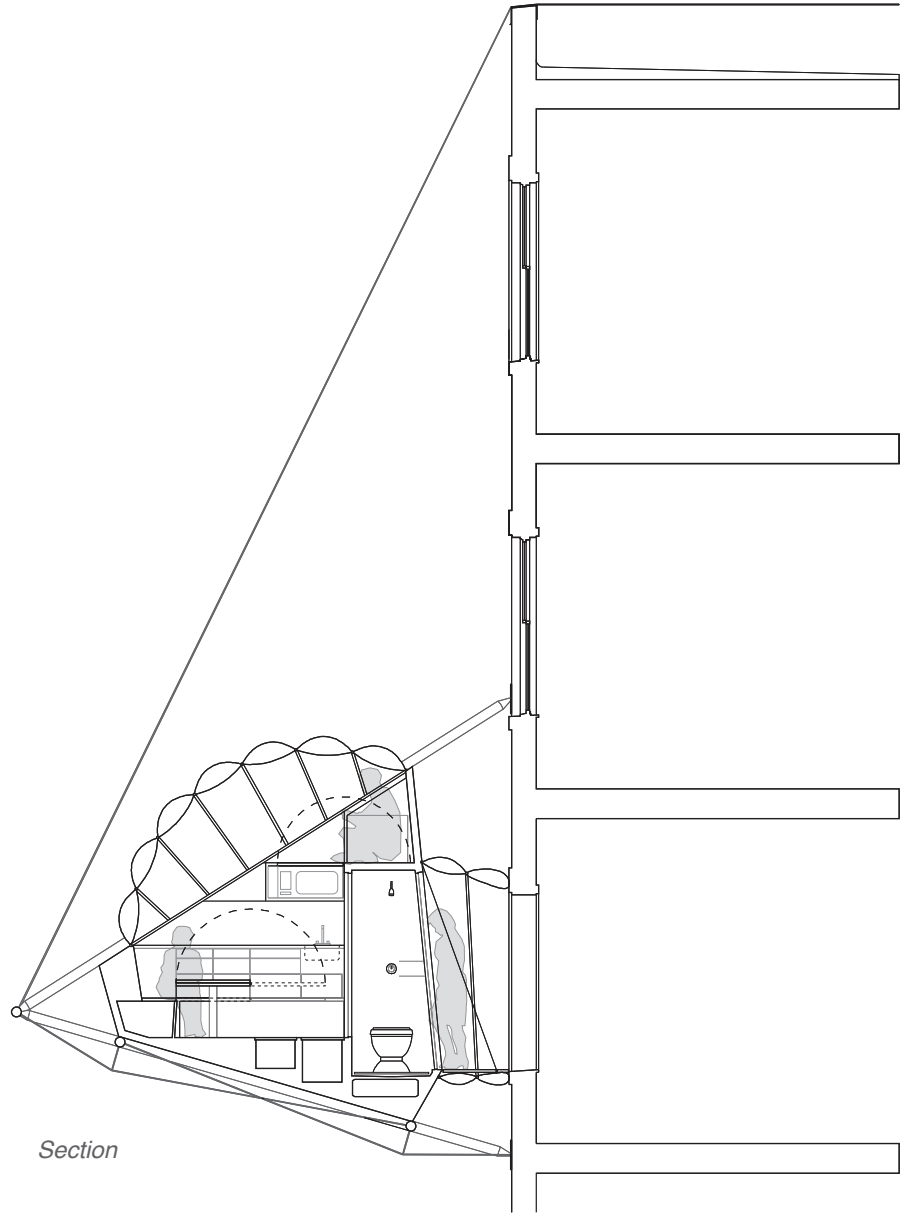

Section





# 5

*Appendix & References*

*Excerpts from:*

*THE US MODEL STATE EMERGENCY  
HEALTH POWERS ACT*

As part of the federal government's plan to streamline domestic biosecurity in the face of looming threats from both biological terrorism and emerging diseases, government drafted the Model State Emergency Health Powers Act as a piece of model legislation to be ratified and amended by the states individually. The rationale being that the localized nature of most biological disasters are best dealt with at a state and local level, however during a crises that may have national effects, coordination between states will be facilitated if they share certain core elements of their disaster relief plan.

“The federal government has authority in the area of public health under its specific constitutional role to regulate interstate and foreign commerce, and its power to tax and spend to provide for the general welfare. States have a long history of broad authority to protect the public health under what is known as their inherent police powers... It brings into focus the powers that are required for government to conduct the activations of public health, including the control of bioterrorism...has been introduced in one form or another in the legislatures of 43 states.” Bronze, 83

#### *PREAMBLE*

The act authorizes the collection of data and records, the control of property, the management of persons and access to communications. It allows for immediate investigation by granting access to individuals’ health information under specified circumstances.

They are also empowered to provide care and treatment to persons who are ill or who have been exposed to infection, and to separate affected individuals from the population at large for the purpose of interrupting the transmission of infection disease.

The act thus provides that, in the event of the exercise of emergency powers, the civil rights, liberties, and needs of infected or exposed persons will be protected given the primary goal of controlling serious health threats.

#### *ARTICLE V: CONTROL OF PERSONS*

To compel a person to submit to a physical examination and/or testing as necessary to diagnose or treat the person.

The public health authority may exercise the following emergency powers over individuals: Establish and maintain places of isolation

and quarantine and require isolation or quarantine of any person by the least restrictive means necessary to protect public health. All reasonable means shall be taken to prevent the transmission of infection among the isolated or quarantined individuals.

The public health authority may isolate or quarantine a person without first obtaining a written, ex parte order from the court if any delay in the isolation or quarantine of the person would pose an immediate threat to the public health.

To compel a person to be vaccinated and/or treated for an infectious disease.

87

#### *ARTICLE IV: CONTROL OF PROPERTY*

Facilities: To close, direct and compel the evacuation of, or to decontaminate or cause to be decontaminated any facility of which there is reasonable cause to believe that it may endanger public health.

To procure, by condemnation or otherwise, construct, lease, transport, store, maintain, renovate, or distribute materials and facilities as may be reasonable and necessary for emergency response, with the right to take immediate possession thereof.

To control ingress and egress to and from any stricken or threatened public area, the movement of persons within the area, and the occupancy of premises therein, if such action is reasonable and necessary for emergency response.

## ENDNOTES

- <sup>1</sup> “Swine Flu Death Toll at 10,000 Since April,” *The New York Times*, 10 December 2009.
- <sup>2</sup> Mike Davis. *The Monster at our Door*. (New York: Henry Holt and Company, 2006), p. 25.
- <sup>3</sup> Davis, 33.
- <sup>4</sup> *Ibid.*, 25.
- <sup>5</sup> Stacey Knobler, Alison Mack, Adel Mahmoud and Stanley Lemon. *The Threat of Pandemic Influenza: Are We Ready?* (Washington D.C.: The National Academies Press, 2005), p. 13.
- <sup>6</sup> Knobler, 13.
- <sup>7</sup> Davis, 126.
- <sup>8</sup> Tuabenberg in Davis, 11.
- <sup>9</sup> Davis, 19.
- <sup>10</sup> Robin Roy Britt, *Virtual Pandemic: 90 Days to Infect the Entire US*, [http://www.livescience.com/health/060405\\_virtual\\_pandemic.html](http://www.livescience.com/health/060405_virtual_pandemic.html) (January, 2010).
- <sup>11</sup> Davis, 70.
- <sup>12</sup> Knobler, 24.
- <sup>13</sup> Davis, 148.
- <sup>14</sup> *Ibid.*, 123.
- <sup>15</sup> Laura McEnaney, *Civil Defense Begins at Home: Militarization Meets Everyday Life in the Fifties*. (Princeton: Princeton University Press, 2000), 25.
- <sup>16</sup> Davis, 123.
- <sup>17</sup> Oleg Schepin and Valdemar V. Yermakov, *International Quarantine*, (Connecticut: International Universities Press, Inc., 1991), 27.
- <sup>18</sup> Schepin, 42.
- <sup>19</sup> Elinor Levy, *The New Killer Diseases*, (New York: Crown Publishers, 2003), p. 237.
- <sup>20</sup> Roy Smith, *Berlin Air Raid Shelter, Flak Towers and Bunkers*, <http://www.geocities.com/lupinpooter/berlin.htm>
- <sup>21</sup> *Air Raid Shelters*, <http://www.caringonthefront.org.uk>
- <sup>22</sup> *Ibid.*
- <sup>23</sup> Kenneth D. Rose, *One Nation Underground: The Fallout Shelter in American Culture*, (New York: New York University Press, 2001), p. 201.
- <sup>24</sup> *Ibid.*, 160.
- <sup>25</sup> *Ibid.*, 102.
- <sup>26</sup> *Ibid.*, 191.

## *IMAGE CREDITS*

Mosquito Bottleneck

R&Sie - <http://www.new-territories.com/>

“What Not to Wear When Worry About the Flu”

New York Times, 11 September, 2009

Fear in the American Suburbs

*Plagues and Peoples*

Micro Compact House

Home delivery : Fabricating the Modern Dwelling

The Spandrobe

Metropolis Magazine

Fashion Flu Masks

<http://workbook.yoriquo.com/>

## WORKS CONSULTED

“Air Raid Shelter.” Caring on the Homefront.org. 7 January, 2010. < <http://www.caringonthehomefront.org.uk/search-the-library/air-raid-shelters/>>.

*American Experience: Influenza 1918.* <http://www.pbs.org/wgbh/americanexperience/influenza/> (January, 2010).

Bergdoll, Barry, Peter Christensen and Ron Broadhurst. *Home Delivery: Fabricating the Modern Dwelling.* New York: Museum of Modern Art, 2008.

Bonze, Michael S. *Biodefense: Principles and Pathogens.* Wymondham, Norfolk, England : Horizon Bioscience, 2005.

Britt, Robin Roy. *Virtual Pandemic: 90 Days to Infect the Entire US.* [http://www.livescience.com/health/060405\\_virtual\\_pandemic.html](http://www.livescience.com/health/060405_virtual_pandemic.html) (January, 2010).

Brower, Jennifer and Peter Chalk. *The Global Threat of New and Reemerging Infectious Diseases.* Arlington, VA: RAND, 2003.

Cecchine, Gary and Melinda Moore. *Infectious Disease and National Security.* Santa Monica: the RAND Corporation, 2006.

Davis, Mike. *Monster at Our Door: The Global Threat of Avian Flu.* New York: New Press, 2005.

Green, Walter G. *The Electronic Encyclopaedia of Civil Defense and Emergency Management.* 7 January, 2010. < <https://facultystaff.richmond.edu/~wgreen/encyclopedia.htm>>.

Henderson, Donald A., Thomas V. Inglesby, Tara O’Toole. *Bioterrorism: Guidelines for Medical and Public Health Management.* Chicago, Ill. : American Medical Association, 2002.

Hong Kong. Department of Health. Outbreak of Severe Acute Respiratory Syndrome (SARS) at Amoy Gardens, Kowloon Bay, Hong Kong, Main Findings of the Investigation. 2003.

Horden, Richard. *Richard Horden: Architecture and Teaching: Buildings, Projects, Micro-Architecture Workshops*. Boston: Birkhauser Verlag, 1999.

Kaminer, Ariel. "What Not to Wear When Worrying About the Flu," *New York Time*, 11 September, 2009.

Knobler, Stacey, Alison Mack, Adel Mahmoud and Stanley Lemon. *The Threat of Pandemic Influenza: Are We Ready?* Washington D.C.: The National Academies Press, 2005.

Levy, Elinor. *The New Killer Diseases*. New York: Crown Publishers, 2003.

McEnaney, Laura. *Civil Defense Begins at Home: Militarization Meets Everyday Life in the Fifties*. Princeton: Princeton University Press, 2000.

McNeil, Donald G. "Swine Flu Death Toll at 10,000 Since April," *The New York Times*, 10 December 2009.

91

McNeill, William Hardy. *Plagues and Peoples*. New York: Anchor Press, 1976.

Moreno, Jonathan D. *In the Wake of Terror: Medicine and Morality in a Time of Crisis*. Cambridge: The MIT Press, 2003.

"Productsphere. The Workspheres Exhibition at MoMA." *Metropolis* 20, Part 8 (2001): 110-113.

Roberts, Jennifer A. *The Economics of Infectious Disease*. New York: Oxford University Press, 2006.

Rose, Kenneth D. *One Nation Underground: The Fallout Shelter in American Culture*. New York: New York University Press, 2001.

Schepin, Oleg and Valdemar V. Yermakov. *International Quarantine*. Connecticut: International Universities Press, Inc., 1991.

United States. Centers for Disease Control and Prevention. The Model State Emergency Health Powers Act. Washington D.C.: The Center for Law and the Public's Health, 2001.

World Health Organization. WHO Global Influenza Preparedness Plan. Switzerland: The World Health Organization, 2005.