

# Open Architecture Framework for Improved Early Stage Submarine Design

by

Eli A. Sewell

B.S., Computer Science, Southern Polytechnic State University, 2001

Submitted to the Department of Mechanical Engineering and the Engineering Systems Division  
in Partial Fulfillment of the Requirements for the Degrees of

Naval Engineer  
and  
Master of Science in Engineering and Management

at the  
Massachusetts Institute of Technology  
June 2010

© 2010 Eli A. Sewell. All rights reserved.

**ARCHIVES**

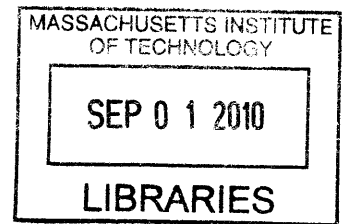

The author hereby grants to MIT permission to reproduce and to distribute publicly paper and  
electronic copies of this thesis document in whole or in part in any medium now known or  
hereafter created.

Signature of Author \_\_\_\_\_

Department of Mechanical Engineering and  
System Design and Management Program  
May 7, 2010

Certified by \_\_\_\_\_

Mark Welsh  
Professor of the Practice of Naval Construction and Engineering  
Thesis Supervisor

Accepted by \_\_\_\_\_

Pat Hale  
Director, Systems Design and Management Fellows Program  
Engineering Systems Division

Accepted by \_\_\_\_\_

David E. Hardt  
Chairman, Department Committee on Graduate Students  
Department of Mechanical Engineering

Page Intentionally Left Blank

# Open Architecture Framework for Improved Early Stage Submarine Design

by

Eli A. Sewell

Submitted to the Department of Mechanical Engineering and the  
System Design and Management Program on May 7, 2010  
in Partial Fulfillment of the Requirements for the Degrees of

Naval Engineer

and

Master of Science in Engineering and Management

## **Abstract**

Could transparency between current disparate methods improve efficiency in early stage submarine design? Does the lack of transparency between current design methods hinder the effectiveness of early stage submarine design? This thesis proposes that coordinating data and design methods from current disparate sources would improve the initial early stage submarine design process. Improvements achieved through knowledge capture include:

- the making available of options in determining key naval architecture values,
- the ability to compare and contrast said options, both by results and underlying principles/assumptions,
- and an overall process for developing key naval architecture values, to be used in later stages of design, that is easily expandable to incorporate further unleveraged design processes or newly developed data.

The designer is encouraged through this approach to critically evaluate the data, customer requirements, and design philosophy they are bringing to the design. Capturing the knowledge of multiple design traditions means the decisions and calculations made while stepping through a design are no longer locked into a single frame of reference. The appropriateness of each decision is better understood within the context of the greater knowledge of submarine design. This flexibility in approach allows decision making such that the assumptions made during design best reflect the design scenario. Use of an open architecture to map how key naval architecture values are handled in different current methods may also provide the designer with insights which would otherwise remain hidden.

Thesis Supervisor: Mark Welsh

Title: Professor of the Practice of Naval Architecture and Engineering

Thesis Supervisor: Pat Hale

Title: Director, Systems Design and Management Fellows Program

## **Acknowledgments**

Thanks to Mark Welsh and Pat Hale for guiding me through, and allowing me to wander through, my educational journey. You will serve as examples of educators, engineers, naval officers and leaders as I take this education in the workforce and beyond.

Thanks to the friends and family that have supported me during these times. To my classmates, thank you for the support that could only be provided from each other. And most special thanks to my wife, Jill, for her patience, care and encouragement.

## Table of Contents

|  |    |
|--|----|
| 1.0 Introduction.....                                  | 8  |
| 1.1 Body of Knowledge.....                             | 9  |
| 2.0 Information: Sources, Uses, Usefulness & Flow..... | 14 |
| 2.1 Information Sources.....                           | 14 |
| 2.2 Information Uses and Usefulness.....               | 18 |
| 2.3 Information Flow.....                              | 21 |
| 2.3.1 Insights from Modularization.....                | 22 |
| 2.3.1.1 MIT SMM.....                                   | 24 |
| 2.3.1.2 Burcher.....                                   | 26 |
| 2.3.1.3 SUBCODE.....                                   | 27 |
| 2.3.1.4 SSX.....                                       | 28 |
| 2.3.1.5 SUBSIZE.....                                   | 30 |
| 2.3.2 Key Commonalities.....                           | 31 |
| 3.0 Implementation.....                                | 32 |
| 3.1 Breadth of Scope.....                              | 32 |
| 3.2 Depth of Scope.....                                | 37 |
| 3.2 Framework.....                                     | 40 |
| 3.2.1 Data Structure.....                              | 40 |
| 3.2.2 Supplementary Tables.....                        | 44 |
| 4.0 Walk-Through.....                                  | 46 |
| 5.0 Conclusions.....                                   | 54 |
| 5.1 Motivation.....                                    | 54 |
| 5.2 Method.....  | 54 |
| 5.3 Observed Benefits and Weaknesses.....              | 57 |
| 5.4 Areas of Improvement and Application.....          | 59 |
| 5.4.1 Areas of Improvement.....                        | 59 |
| 5.4.2 Areas of Application.....                        | 61 |
| 5.5 Closing.....                                       | 62 |
| Bibliography.....                                      | 63 |
| Appendix A – SUBSTART Variable List.....               | 65 |
| Appendix B – SUBSTART Data Structure View.....         | 72 |

## List of Figures

|   |    |
|---|----|
| Figure 1 MIT SMM Design Spiral .....  | 24 |
| Figure 2 MIT SMM Design Flow Chart.....                                     | 25 |
| Figure 3 Burcher Design Flow Chart.....                                     | 26 |
| Figure 4 SUBCODE Design Flow Chart.....                                     | 27 |
| Figure 5 SUBCODE Module List.....   | 28 |
| Figure 6 SSX Simplified Design Flow Chart .....                             | 28 |
| Figure 7 SSX Detailed Design Flow Chart.....                                | 29 |
| Figure 8 SUBSIZE Flow Chart.....  | 30 |
| Figure 9 SUBSIZE Weight/Volume Balance .....                                | 31 |
| Figure 10 SUBSTART Basic Modularization.....                                | 33 |
| Figure 11 SUBSTART Modularization.....                                      | 34 |
| Figure 12 Data Structure Example – $V_{PH}$ .....                           | 41 |
| Figure 13 SUBSTART Data Structure Labeled Example – pvf.....                | 42 |
| Figure 14 SUBSTART Data Table Example.....                                  | 45 |
| Figure 15 Scope of Walkthrough.....   | 46 |
| Figure 16 Calculations from $V_{Payload}$ to $V_{Envelope}$ (Burcher) ..... | 47 |
| Figure 17 Primary and Secondary Values .....                                | 48 |
| Figure 18 Primary and Related Values.....                                   | 49 |
| Figure 19 Alternate Configuration – Primary and Secondary Values.....       | 51 |
| Figure 20 SUBSTART Data Structure Template .....                            | 55 |

## List of Tables

|  |    |
|--|----|
| Table 1 Information Sources Overview.....              | 17 |
| Table 2 Selected Method General Differences.....       | 23 |
| Table 3 Specialized Analyses by Module.....            | 36 |
| Table 4 Imposed Requirement Variable Grouping.....     | 38 |
| Table 5 Inherent Requirement Variable Grouping.....    | 39 |
| Table 6 Number of Calculation Options in SUBSTART..... | 49 |
| Table 7 Values Developed - Alternate Scenario.....     | 52 |
| Table 8 SUBSTART Potential Improvements by Area.....   | 61 |

## **1.0 Introduction**

Ship design is a true interdisciplinary arena. The convergence of structures, hydrostatics, hydrodynamics, control theory, systems design and other areas of study create a subject that is difficult to attempt to comprehend in total. Shipbuilding and ship design is both an ancient art and modern science. The seemingly basic issue of ship design is still full of unanswered questions and areas of study, even as we are advancing well into the computer age. Submarine design is one subset of ship design, and it brings its own twists on the problem of naval architecture. The problem is significant even at the relatively simple, low level of fidelity, work engaged in early stage, or concept, design. Submarine concept design, due to the interconnectedness of the system's variables, and due to the disparate methods developed to approach the problem, can be an opaque process.

There are a variety of established tools/processes/methods available to a beginning naval architect interested in submarine concept design. None of these methods are all encompassing, regarding the entire breadth and depth of the design space. Nor should they be all encompassing at this early stage of design. Each of these methods uses a slightly different approach, utilizing a slightly different core set of values, relationships, historical data and assumptions. While each method will get you "into the ballpark," and ideally will create similar results with similar input, it may be overwhelming to ask a beginning submarine designer with no context to parse the differences and choose the method most appropriate to their task. Practically, the decision on what method to use may be based on convenience, not optimality, leaving the designer without an understanding of the assumptions that are entailed in their choice. Familiarity and/or proximity are naturally strong factors in the decision of method/tool/etc. to use. Working within

a well known tradition is not necessarily a detriment in the overall execution of design and learning, but does fundamentally limit the designer and their design experience.

The tool developed herein, SUBSTART, endeavors to make the entry level process of submarine concept design more transparent to the novice designer, while providing a unique planning tool to the more experienced designer. SUBSTART is not a replacement for those tools currently in use, and is not a design methodology in-and-of itself. Quite contrarily, existing methods are leveraged in such a way as to expose the designer to what insights each existing method can provide, and enable a synergy through the use of more than one existing method, chosen on a value by value basis. The tool has been developed in such a way, that it may be updated to incorporate advances in the field, if other design methods arise, or if new data is acquired. SUBSTART is a vehicle for knowledge capture that provides the designer with a higher granularity of choice throughout the early stage design process through a transparent comparison between existing methods/data at a fundamental level of key naval architecture values, while providing a way to incorporate newly acquired knowledge. Prudent use of the knowledge captured and presented in SUBSTART allows the designer to make more informed decisions, improving their understanding of the subject and improving the design itself.

### **1.1 Body of Knowledge**

As an engineering discipline, naval architecture has developed a number of methods to answer the questions concerning ship design and construction. In areas where the physical principles of the system are well understood, the information needed to analyze the system is obtainable, and the computing power to process the data is available, naval architects can apply first principles analysis. First principles analysis is an area which academia and industry continually try to expand the state of the art and the state of the practice. By necessity, experience is the preferred

guide in areas which lack such complete understanding. Experiential exploitation is the oldest method of (re)engineering and is primarily used today in the application of parametric equations and design lanes. The development of data which feeds these experiential methods is an effort as, if not more, important to academia and industry as first principles research. This data includes model testing as well as analysis of full scale previous endeavors. The naval architects' body of knowledge consists of:

- data sets,
- first principles engineering equations, and
- experientially developed parametric equations and thumb rules.

How does today's beginning submarine designer leverage this extensive body of knowledge?

This is a nontrivial task that helps define our education as naval architects. Many well-developed design methodologies have been developed and used in the field with success. Often, a designer is presented with a limited number of these methodologies and the design tools developed from them. This may be due to limitations of the copyright, licensing or classification, fiscal or space limitations in filling the bookshelves, ignorance in being unaware of their existence, or simply the informed choice to not maintain a method description or tool for any of various valid reasons, such as lack of tool validation or unsuitable learning curves.

Maintaining a collection of method descriptions and tools is the first step in leveraging this body of knowledge.

The body of knowledge available to the author regarding early stage or concept design for submarines at project's start primarily consisted of two main tools/methods. The first was the MathCad/Excel model and course notes used in the MIT 2N Professional Summer Submarine

Concept Design course developed from Captain Henry Jackson's work in submarine concept design (Reed et al; Jackson, "Submarine Design Trends"). The second was the methodology championed by Roy Burcher and Louis Rydill, described in their book Concepts in Submarine Design, and leveraged in the tutorials and training provided by Graphics Research Corporation (GRC) for use with their PARAMARINE design tool (Burcher et al).

Once the body of knowledge is gathered, a critical analysis is required regarding what assumptions are made, what information is required, and what information will be developed by each tool/method before choosing how to proceed. Assumptions may be simple, asserting a thumb rule, or fundamental, concerning the development of the data behind the resulting parametric equations. For example, Burcher and Rydill make a simple assumption that pressure hull volume can be initially estimated based on a known payload volume (the factor applied varies between descriptions). Whereas, the majority of the data used by Jackson is from U.S. designed, nuclear powered, single screw, fast attack submarines. Therefore, many of the parametric equations used by Jackson may suffer in their applicability if the designer is deviating from this mold (effectively, the designer is no longer interpolating from useful data, but extrapolating from data that may or may not be relevant).

Parallel to sorting out the inferred assumptions, the designer must determine what data they need to gather as inputs into the design process. Though there will undoubtedly be overlap between what is required for each method, there may be notable differences which could influence which method is most useful for a given design scenario. Overall, the U.S. approach to submarine concept design is weight based. A hull form is wrapped around those weights, and iterations balance weight and buoyancy (buoyant volume), followed by balancing required and available area. Burcher and Rydill instead use a volumetric centric approach, placing weights into the

resultant volume. These are not the only valid methodologies. The author's design team entered the hull area/volume/weight balance with detailed area requirements, developing the required volumes and weights from the area definition.

An understanding of the inputs required by a given method may also reveal that there is information required that is unknown by the designer. Traditionally, in these cases, the designer must make an educated guess, though they may often be without context, to proceed through the design.

It may occur that the method used does not provide all the outputs desired, or does not provide the fidelity/confidence desired. In this case, other tools or methods must be brought to bear. This may occur in areas that affect and are affected by a major portion of the design such as structural analysis. It is particularly likely that subsets of the design such as propeller design or engine selection will require more specialized analysis.

Traditionally, once a designer has begun applying a particular method, that method is completed to the exclusion of any others. Maintaining solely within the strengths of the local design tradition precludes the ability to leverage portions of other methodologies that have something offer. This also may force the designer to make uneducated decisions on inputs which are required by the design tool. The designer is forced to accept the effects, at all levels, of the assumptions underlying the design methodology in use.

It is necessary to note that SUBSTART is meant only to augment, not replace, an existing design tradition. Local design traditions have grown out of a particular methodology and served the needs of the local design community. This is a natural and needed occurrence, for a number of reasons. Use of differing units, or different approaches to accounting the key naval architecture

values of interest, make it difficult to use more than one methodology concurrently. This may also apply to using third party data for comparison or context. The opaqueness due to “apples-to-oranges” comparisons hinders the designer from leveraging the entire body of knowledge. The design experience would be improved if an “apples-to-apples” transparency allowed the designer to leverage the most relevant data and most appropriate calculation methods from across the entire body of knowledge. It is this issue of knowledge capture that the SUBSTART framework attempts to address.

## **2.0 Information: Sources, Uses, Usefulness & Flow**

### **2.1 Information Sources**

The submarine design body of knowledge can effectively be subdivided into two interrelated categories: methods and data. The methods that this thesis will primarily be concerned fall into two major categories: the works of Henry Jackson (Jackson, “Submarine Parametrics”; “Submarine Design Trends”) and the works of Roy Burcher (Burcher et al). To round out these categories of methodology, derivative works of each will be given consideration, as will some mention of works deriving from neither Jackson nor Burcher.

These works were chosen because they were most influential on the design process of the “All Electric Conventional Powered Submarine Concept Design” year-long design project conducted by Matthew Frye and Eli Sewell (Frye et al) hereon referred to as SSX, or they provide a representative compliment to the primary considered works necessary to build this framework for future expansion, summarized in Table 1. The data considered in this thesis will be those informational areas most closely tied to the considered methods, or that required to provide a representation of the framework’s potential for future expansion. The body of data considered is in no way all-inclusive in either depth or breadth.

Jackson’s collection of notes and papers is an important contribution to the overall submarine designer’s body of knowledge for two reasons. First, Jackson has developed the preeminent collection of information on U.S., single screw, nuclear powered, fast attack submarines available in open literature (Jackson, “Submarine Design Trends”). Second, Jackson has presented his method of how to develop parametric equations and balance engineering principles with information found through comparative naval architecture (Jackson, “Submarine

Parametrics”; “Submarine Design Trends”). His contribution is two-fold, the design method and data, and the methodology used to develop the design method and data.

Derivative works of Jackson include:

The MIT XIII-A Submarine Math Model is the computational culmination of Jackson’s many notes and papers regarding submarine design (Reed et al). This is the primary source from which Jackson’s work will be leveraged, as it is a complete and useful stand-alone design tool.

Hereon, the MIT XII-A Submarine Math Model shall be referred to as MIT SMM.

Grant Thornton’s work is an extension of the MIT SMM (Thornton). It was designed to use modifying factors in the MIT SMM to model the effects of air independent propulsion (AIP).

Modern AIP was an area that was not within the scope of the MIT SMM because of Jackson’s focus on nuclear powered vessels.

Kai Torkelson’s work used the MIT SMM as the basis for conducting a comparative naval architecture study of diesel-electric submarines (Torkelson). The model was highly modified, changing from a design to an analysis tool. Nevertheless, it finds its place on this list because it is useful in showing how an established design method can be used to instead develop key naval architecture values, relationships and comparative information from raw data sources. Also, it was able to modify the MIT SMM such that its application was appropriate for diesel-electric, versus nuclear, submarines.

Works and derivatives of Burcher include:

Concepts in Submarine Design, by Roy Burcher and Louis Rydill provides the best explanation of Burcher's assumptions and thought process (Burcher et al). It also provides some explicit areas of method and comparative naval architecture data.

*UCL Design Procedure for the GRC Submarine Concept Design Tool* was the most in-depth and generalized computational expression of the Burcher methods (UCL). Created at University College London, the procedure applies many of the concepts found in Concepts in Submarine Design to be used in the QinetiQ GRC 3-D submarine design tool PARAMARINE.

The tutorials provided by QinetiQ GRC for early stage submarine design in PARAMARINE are a more specific walk through of the PARAMARINE design software (QinetiQ, Paramarine Submarine Introduction Training Course, Paramarine Submarine Early Stage Design Training Course). The design software is very open-ended regarding the relationships created between its modules. These tutorials provide step-by-step instructions on forming these relationships using examples derived from Burcher's work. While these tutorials are primarily focused on the nuances of the design software, the relationships which are input by the user are good examples of low level relationships which come from the Burcher methodology.

Two examples of methodologies which do not inherit the assumptions of Jackson or Burcher are Ulrich Gabler's *Submarine Design* (Gabler) and John Stenard's "Comparative Naval Architecture of Modern Foreign Submarines" (Stenard). Gabler's German U-Boat background is reflected throughout his book, as the background where his underlying assumptions lie. He presents a method for reporting surfaced and submerged endurance range that is more robust than either Jackson or Burcher, and is an example of a third-party methodology being used in previous MIT Course 2N Naval Architecture projects that were Jackson dominant.

Stenard presents a very different situation and set of assumptions. Even though Stenard’s background is in U.S. nuclear-powered submarines, his work uses Jackson’s methods of parametric equation development and comparative naval architecture to create a wholly new body of work through diesel-electric information in open literature.

SUBCODE is a design tool developed General Dynamics, Electric Boat Division and the Department of the Navy Naval Sea Systems Command, NAVSEA. It is maintained by Electric Boat and was described by Chris Mahonen, Will Spradley, and Matt Gerdon in the 2007 ASNE paper “Automating Early Stage Submarine Design: Development of the Submarine Concept Design (SUBCODE) Program.” SUBCODE is not for public use due to its proprietary nature, but it is an excellent example of a parallel to the MIT SMM used in industry incorporating privately developed relationships (Mahonen et al).

| Author        | Produced Methodology, Tutorial, Tool, Study or Design   |
|---------------|---|
| Jackson       | A description of the process of developing/using parametric equations from historic data                                      |
| Jackson et al | A methodology for ship design based on parametric equations expressive of the US design tradition                             |
| Reed et al    | MIT SMM – A tool that provides the most complete computational expression of Jackson’s methodology                            |
| Thornton      | SUBSIZE – A tool developed to supplement the MIT SMM with AIP capability  |
| Torkelson     | A comparative naval architecture study using the MIT SMM as its basis   |
| Burcher et al | A methodology for ship design expressive of the British design tradition  |
| UCL           | A tutorial designed to use the Burcher methodology within the PARAMARINE design tool  |
| GRC           | A set of tutorials designed to learn the PARAMARINE design tool following the Burcher methodology                             |
| Gabler        | A methodology for ship design expressive of the German design tradition   |
| Stenard       | A comparative naval architecture study using Jackson’s development processes  |
| Mahonen et al | SUBCODE – A tool developed by US government and industry, maintained by industry, combining Jackson’s methodology with        |
| Frye et al    | SSX – An academic point study design using a hybrid of Jackson’s (MIT SMM), Burcher’s (PARAMARINE) and original methodologies |

**Table 1 Information Sources Overview**

The data which may be useful to the early stage submarine designer is quite varied. Each of the methods above have used similar, if not the same, basic data as a basis. Example categories of where this data resides include:

- Comparative Naval Architecture
  - Raw general data (Jane's, Interavia)
  - Formatted data (Reed et al, Torkelson)
- Previous point designs
  - Weight reports
  - General Arrangements
- Component lists (payload, powering equipment, etc.)
- Area studies
  - AIP (system concepts, component prototype results, etc.) (Thornton)
  - Control plane configuration
- Other data that could be used to build useful parametric equations

## **2.2 Information Uses and Usefulness**

At different points in the design, different data (or different fidelities of data) can yield differing types of information. This is best seen in the multiple passes of a spiral design loop. Still, even in the first pass through the spiral, there are mini-iterations and checks as new information becomes available. From most to least detailed, the following list describes what type of calculations might be performed:

- Geometry assisted calculations – Feedback from 3-D modeling provides the highest level of fidelity (Area/volume balance, static and dynamic stability analyses, finite element analysis of structures).
- Detailed locations/weights/volumes/areas – Could be for equipment (diesel engines, motor support equipment) and other components (sanitary tanks, air flasks) or for gross compartment level information (storeroom, battery well).
- First principles engineering calculations – May be scalable with the fidelity of input information (powering and resistance calculations).
- Factor-based engineering estimates – Useful in areas where either the calculations or fidelity of inputs are difficult to obtain (initial structures estimates). Factors of safety provide confidence in the viability of results based on experience.
- Design lanes – Comparative naval architecture analysis provides a frame of reference to the designer from which to interpolate by providing historical precedence (length-to-diameter ratio vs. submerged speed, SWBS group weight and volume ratios).
- Initial estimates – Lacking any other reference, sometimes values still must be chosen to move ahead in the design based on designer experience. Often times these values can be revisited once the design has matured (required shaft horsepower). This method also includes extrapolation from historical data when the design does not fall into the precedent ranges.

Experience has proven that simply having a repository of data, perhaps browsable in some fashion, is not useful. In fact, it is possible for such a deluge of information to be harmful to the efficiency, and even the effectiveness, of the associated process. That leads to the pertinent

questions: What facets of information are important enough to be brought to attention, and how should that information be presented so that it is useful?

Three important categories summarize the most pertinent data attributes: the attributes of the data itself (name, value, units), the applicability of the data (method, inherent assumptions, confidence), and how the data relates to others (upstream and downstream traceability, or how it fits in the overall modular view). Attributes for each key naval architecture value include:

- Value name
- Value units
- Values calculated
- Value chosen from options
- Methods that developed these values
  - Values that feed into these methods
    - Name
    - Numerical Value
    - Units
  - Confidence in these values/methods
    - From assumptions inherent in methods
    - From fidelity of data

Designing a data structure for use by novice users in an updatable database requires a level of simplicity to be useful. This simplicity must be addressed regarding the ease of use of the data structure and the ease of updatability of the database. The sources and methods of calculation may be varied, as seen above, but the way they are used is general enough that a uniform simple

data structure is sufficient. Dealing with error in the data is the most varied issue and specific dealing with that cannot be easily supported in the data structure.

### **2.3 Information Flow**

Information flow considers two things: traceability and modularization. The connections between the naval architecture values are most enlightening to the early stage submarine designer. The importance of information flow can be seen as beyond that of the individual calculations of naval architecture values.

These binding relationships are only as valid or helpful as their individual calculations. These calculations are, of course, the medium between which the naval architecture values are related to one another. Herein lies the importance of traceability between values. Ideally, traceability is easy for designer to follow, both up and downstream of a given value.

Most design methodologies abstract the many steps and relationships of the design process into larger functional blocks, or modules. These modules may be designed such that they address major design goals, such as area/weight balance, development of the hull shape, structures, or cost estimates. The abstraction that modularization provides usually helps the designer grasp the key concepts of the design, though the constraints of a poor modularization can impose a structure that may not reflect the true lines of traceability found between values. This imposition may have the effect of hiding insights the designer may not otherwise gain. Modularization of the variables should be organic, driven by the relationships that are prevalent in the calculation options. System modularization should be revisited commensurate with updates to the inter-value relationships.

### **2.3.1 Insights from Modularization**

Five different methods or applications were analyzed regarding their information flow, represented by their modularized flow charts. Significant differences are first discussed and summarized in Table 2. Subsequently, an investigation of their similarities provides insight into the underlying tenets of early stage submarine design. Against these tenets, questions concerning process innovation may be posed.

There are some key differences between the design methodologies used in the MIT SMM, in Burcher's concept design description, and in SUBCODE. Even more differences can be seen in the applications detailed by the creation of the SSX design and SUBSIZE. These differences account for differing areas of focus as well as differing base assumptions, summarized in Table 2. It is interesting that these differences are not obvious in comparisons of their high level modularizations.

|         | Purpose   | Focus   |
|---------|---|---|
| MIT SMM | <p>Academic design tool developed to:</p> <ul style="list-style-type: none"> <li>capture design information from the US submarine design tradition as developed and presented by Jackson,</li> <li>utilize that knowledge in a robust and user friendly model for concept exploration and education.</li> </ul>   | <p>Weight accounting and estimation are of primary importance, relating to the weight based historical information available.</p> <p>Incorporates conventions of US submarine design.</p>   |
| Burcher | <p>Educational explanation of concept design to:</p> <ul style="list-style-type: none"> <li>provide a simple first pass through the design spiral,</li> <li>capture design information used in the British submarine design tradition.</li> </ul>   | <p>Weight/space balance focused on volume definition, assuming the design is arrangement limited. Volumes are then related to weights by density factors, enabling balancing of the ship.</p>   |
| SUBCODE | <p>Industrial design tool developed to:</p> <ul style="list-style-type: none"> <li>accurately model current US submarines at a concept design level,</li> <li>capture internal designer knowledge,</li> <li>apply the above to quickly develop robust point designs for future concepts studies for a wide spectrum of concepts (i.e. – designs may vary from large nuclear boats to small AIP vessels).</li> </ul> | <p>Incorporates proprietary knowledge with Jackson’s information in a more flexible interface. Key points as stated in (Mahonen et al): adjustable level of detail, complete user control over an easily understandable modeling process, allows for easy and rapid modifications to the program.</p> |
| SSX     | <p>Academic point design developed to:</p> <ul style="list-style-type: none"> <li>explore diesel-electric submarine design,</li> <li>incorporate a reconfigurable wet/dry payload space,</li> <li>provide forward deployed ISR, SOF and MIW capability.</li> </ul>  | <p>Combines Burcher and Jackson methodologies through the use of the PARAMARINE design tool augmented by the MIT SMM and original calculations.</p> <p>Weight/space balance focuses on area information versus volume (Burcher et al) or weight (Jackson, “Submarine Design Trends”)</p>              |
| SUBSIZE | <p>Academic tool developed to:</p> <ul style="list-style-type: none"> <li>capture AIP information in a way to be usefully leveraged within the MIT SMM.</li> </ul>  | <p>Utilizes the depth of design information in the MIT SMM while addressing the lack of information regarding sizing non-nuclear powered ships. Provides a ship sizing module that modifies the MIT SMM machinery sizing algorithms with parametric equations developed from AIP system data.</p>     |

**Table 2 Selected Method General Differences**

Further analysis incorporates a high level view through their design processes, as represented in the following flow charts. Insights regarding their similarities, and further differences as appropriate, will be presented as each of the following design methods and applications are examined, in the following order: MIT SMM, Burcher, SUBCODE, SSX, SUBSIZE.

### 2.3.1.1 MIT SMM

The following figures were taken from “Once Through the Design Spiral” (Warren), as part of the MIT Course 2N Professional Summer Submarine Design Course.

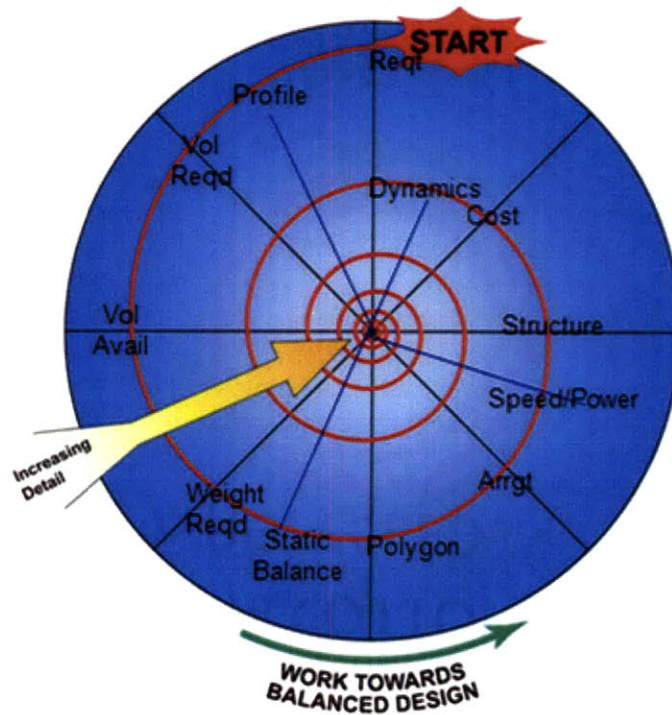

Figure 1 MIT SMM Design Spiral

The design spiral is a traditional way of viewing the design process. A more detailed walkthrough of the MIT SMM design spiral, Figure 1, is found in Figure 2, including iterations that are not seen in the spiral above.

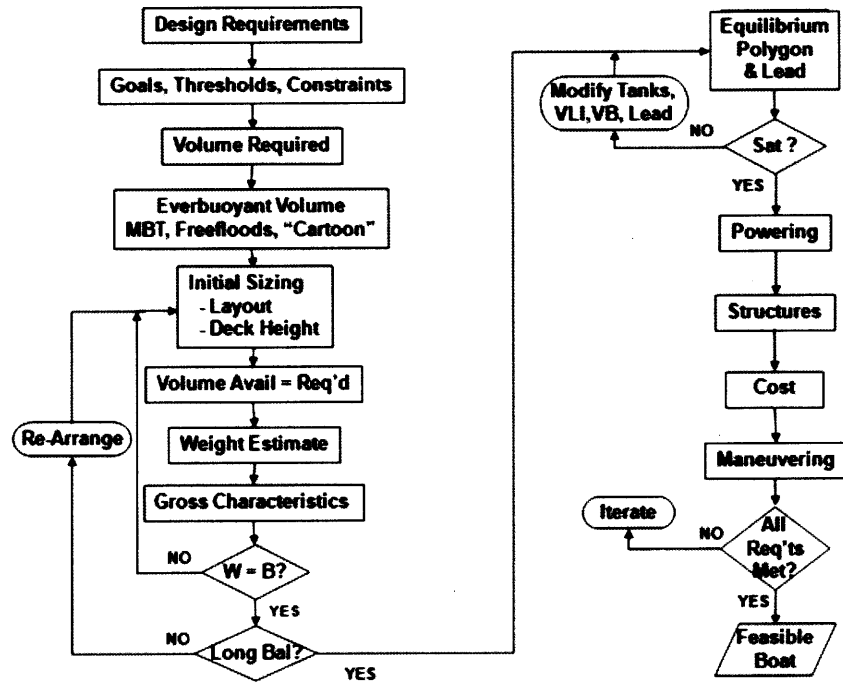

Figure 2 MIT SMM Design Flow Chart

The iterations shown on the MIT SMM flow chart highlight the models primary concern with “wrapping a hull.” Balancing weight and buoyancy at a gross level, then longitudinally, is of utmost concern to the submarine design. Next, ensurance that neutral buoyancy can be maintained in all load conditions completes the design to the point where the follow on analyses may be conducted (Powering, strucures, cost, maneuvering).

### 2.3.1.2 Burcher

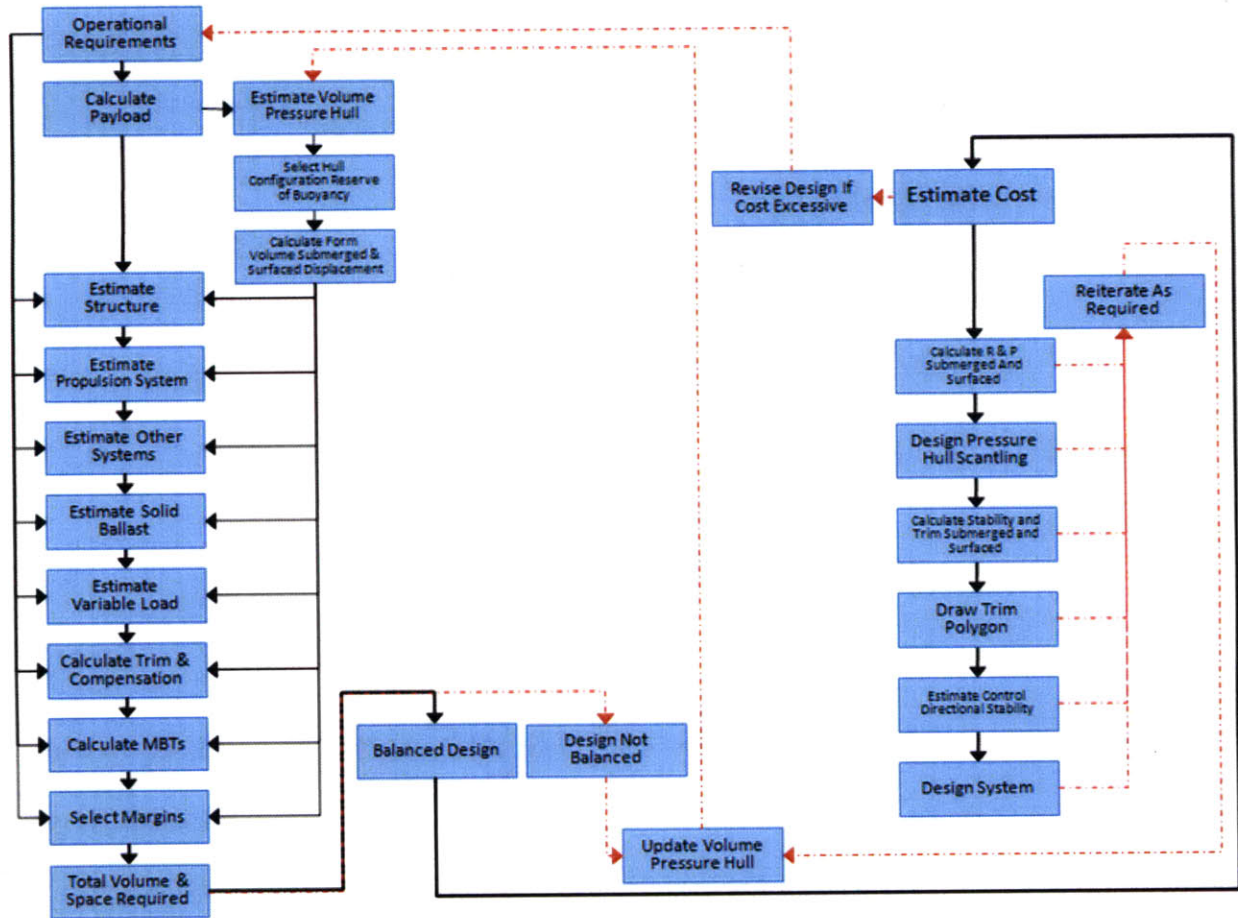

Figure 3 Burcher Design Flow Chart

Figure 11.4 of (Burcher et al) was transcribed above in Figure 3. Dashed lines were added to highlight paths of iteration. The space/weight balance again is the first key iteration point of the design. Though, in Burcher, all initial estimates follow from payload volume as opposed to following from a cartoon as in the MIT SMM. Verification of weights to achieve a balanced design, to the point of a satisfactory trim polygon, occurs at a much later stage than in the SMM, instead focusing primarily on the volume and area balance early on. Cost is also analyzed mid-design, contrary to the other design processes analyzed which analyze cost at design completion.

The initial subset of the process, developing form volume from payload volume, was used as the basis of SUBSTART's proof of concept.

### 2.3.1.3 SUBCODE

The following figures were taken from "Automating Early Stage Submarine Design: Development of the Submarine Concept Design (SUBCODE) Program" (Mahonen).

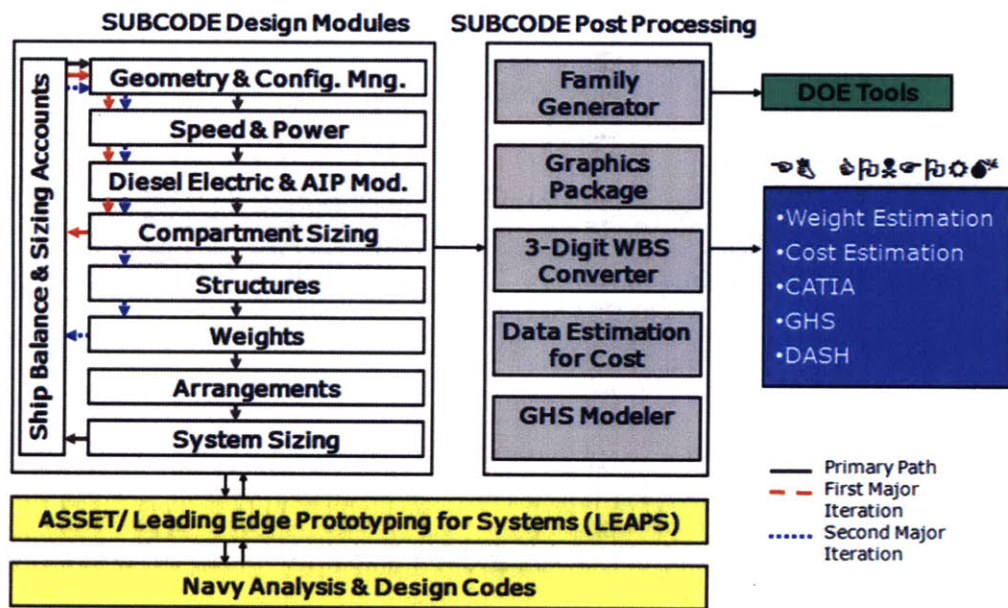
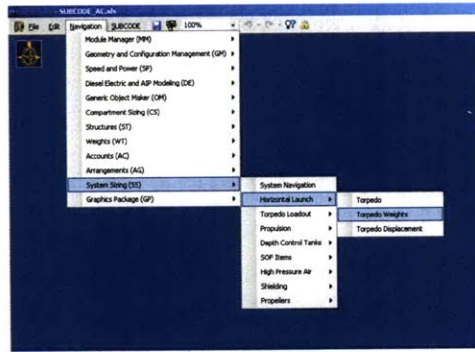

Figure 4 SUBCODE Design Flow Chart

Figure 4 shows the SUBCODE design flow chart in relation to tools external to the SUBCODE design spiral. ASSET, LEAPS and other analysis and design codes augment SUBCODE design modules where appropriate. SUBCODE is also designed to take advantage of the considerable amount of weight based data available from previous U.S. submarine designs. It also outputs using U.S. submarine design conventions, reflecting its development by domestic government and industry. Unlike the MIT SMM, to allow for flexibility to analyze non-nuclear powered vessels, SUBCODE considers speed and powering early in the design process.

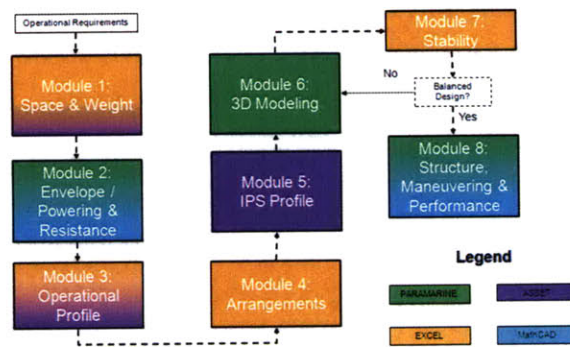

**Figure 5 SUBCODE Module List**

The SUBCODE module list, Figure 5, shows the internal breakdown of the SUBCODE System Sizing module. It also shows the Generic Object Maker module, not included in the the SUBCODE design flow chart. This module provides a portion of SUBCODE’s capability to provide a flexible design environment.

### 2.3.1.4 SSX

Figures 6 and 7 are from “All Electric Conventional Powered Submarine Concept Design” (Frye et al).



**Figure 6 SSX Simplified Design Flow Chart**

Figure 6 provides a high level view once through the design spiral, while Figure 7 shows a more detailed breakdown, including major iteration paths. The SSX design process combined calculations from SMM and Burcher with self created calculations. The Operational Profile

module is mostly independent work, required to be explored indepth early in the design process due to the SSX being diesel electric point design. Combined with the Powering module, the Operational Profile module allowed for intelligent sizing of the diesel engines, battery and fuel stowage.

Similar to Burcher, requirements were expressed in terms of their space requirements with densities applied to develop building block weights. The trim polygon was only fully developed after the majority of the geometry was defined. Unlike Burcher, space requirements were developed through an area, vice volume, analysis.

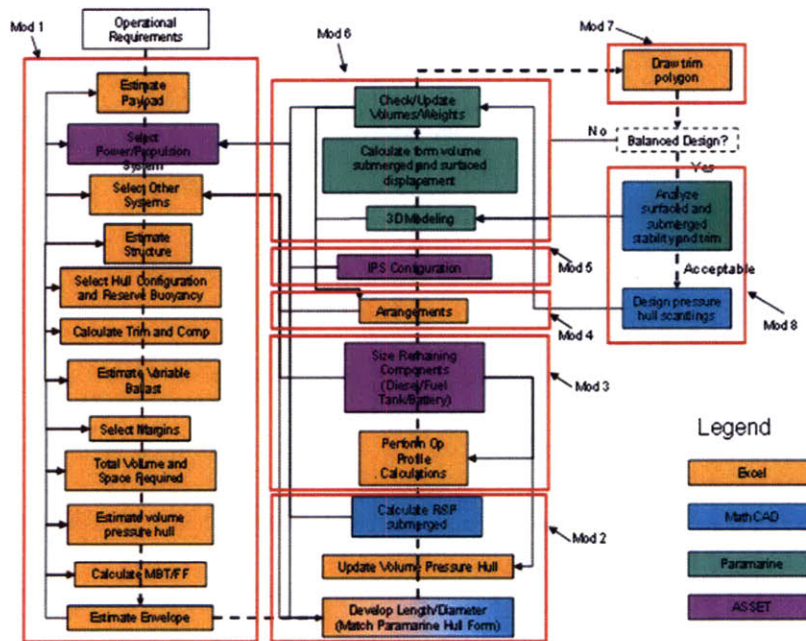

Figure 7 SSX Detailed Design Flow Chart

### 2.3.1.5 SUBSIZE

The following figures were taken from "A Design Tool For the Evaluation of Atmosphere Independent Propulsion in Submarines" (Thornton).

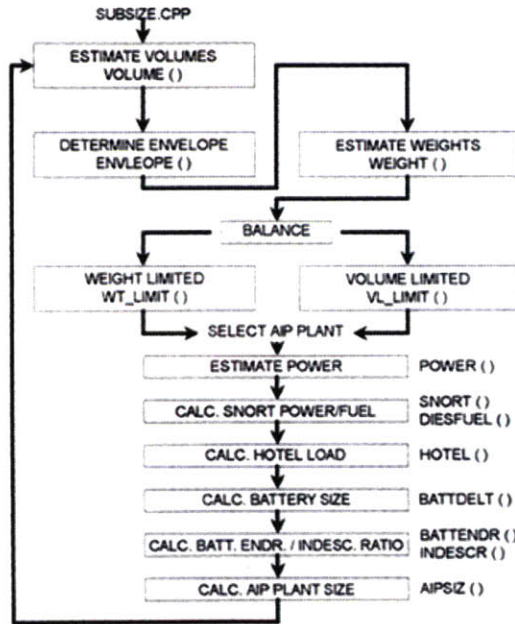

Figure 8 SUBSIZE Flow Chart

SUBSIZE was developed to provide intelligent sizing for diesel-electric and air independent propulsion (AIP) systems. SUBSIZE grew out of, and is designed to supplement, the MIT SMM. It follows the overall MIT SMM design methodology, but uses information from diesel and AIP systems to design the machinery and associated areas instead of the nuclear information assumed by the MIT SMM. Figure 8 shows that power calculations are of primary importance to an AIP or diesel-electric ship design, consistent with Burcher and SSX. Figure 9 shows that the internal accounting of the weight and volume balance is consistent with Jackson and the MIT SMM.

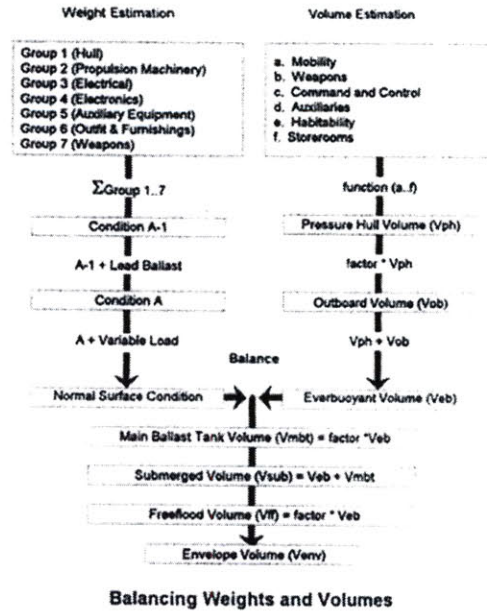

Figure 9 SUBSIZE Weight/Volume Balance

### 2.3.2 Key Commonalities

In all cases, the design process iterates in two cases: the design requirements are not met, or ship design itself does not converge. These cases expose two general areas that may be used to account for all aspects of a concept design: imposed and inherent requirements. These areas will be explored in the implementation of SUBSTART.

Balancing space and weight requirements is a central step in all methods surveyed. Defining the space and weight requirements is a required step that is handled with varying levels of fidelity, from customer definition to parametric estimate. Further common steps include stability and structural analyses to ensure the ship floats in both surfaced and submerged conditions while maintaining hull integrity. Maneuvering, powering and controllability are other common analyses required for a viable design. Lastly, the design must be capable of performing the mission for which it is designed. Such key design parameters will vary between designs, but tend to include characteristics such as depth, speed, payload capacity and deployment capability, manning and cost.

### **3.0 Implementation**

SUBSTART is meant to aggregate the positive aspects of other design methods and related data within a framework that is easy to use and update. Implementing such a framework requires setting an initial scope, developing the structure of the framework, applying the lessons learned from the background works, determining the usefulness of the result and finally populating the framework beyond the initial scope. At the end of this process, SUBSTART will be the useful tool it is intended to become, moving from a simple knowledge capture tool to a nuanced design aid. The remaining sections of this thesis will determine the scope and data structure as well as provide a subset of implemented values to provide proof-of-concept.

The works discussed thus far barely touch the tip of the iceberg regarding the breadth and depth of the submarine design body of knowledge. Other sources, such as *The Submarine Registry and Bibliography*, provide a more comprehensive view of submarine-related literature (Paine). The resources required to gather, format and present such a large collection of information is prohibitive for an easy-to-use, first pass early stage design tool. Therefore, the question of what information to include in the implementation of SUBSTART must be answered.

#### **3.1 Breadth of Scope**

Consideration of imposed and inherent requirements provides a starting point from which to define the breadth of scope appropriate to SUBSTART. Imposed requirements can also be thought of as customer specifications or mission capabilities. Likewise, inherent requirements specify those things that are inherent to the submarine platform as a whole. A submarine, by its nature, must be able to maintain neutral buoyancy while submerged. The balancing of the ship to achieve a satisfactory equilibrium polygon is an inherent requirement, whereas the depth the ship can reach and maintain is an imposed requirement. The space available in-hull, measured in

either area or volume, must be equal or greater to the space required by ship systems, etc.

Convergence of the design to achieve the balance between available and required area or volume is an inherent requirement, whereas the deck area and stack length required for a given payload is an imposed, or external, requirement.

While all of these design facets, and the naval architecture values associated with them, are interrelated, it is useful to group key naval architecture values into their respective modules. Each of the above methodologies approaches this issue with differing results. It is difficult, as well as unhelpful, to attempt to rank one modularization's superiority over another. Rather, each methodology's modularization should be evaluated as to its appropriateness within the given design method. These modularizations are arbitrary abstractions meant to help the designer. If a given way of looking at the design is not beneficial, another viewpoint should be used instead, resulting in a different modularization. A general modularization of design values is used through the rest of this thesis and applied as the set of initial modules for SUBSTART, shown in Figure 10. This modularization will help highlight the commonalities found above.

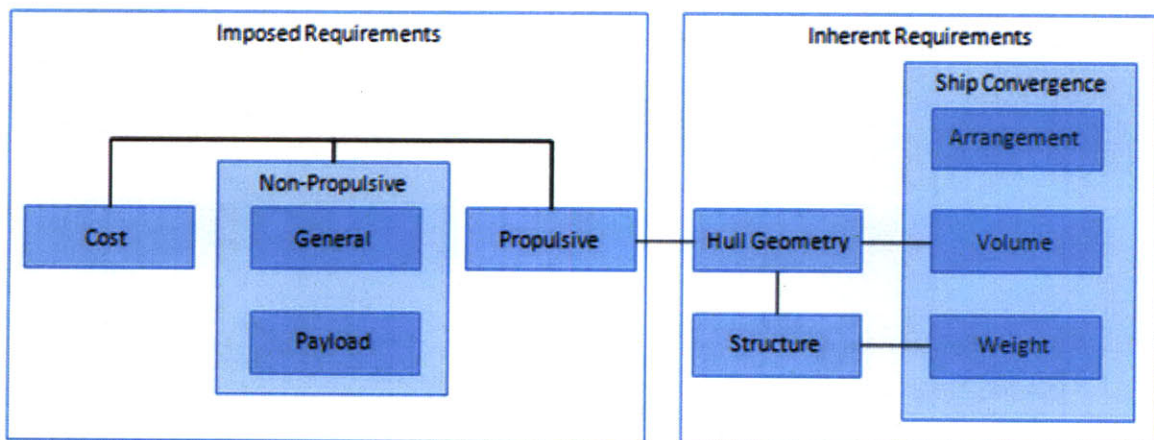

Figure 10 SUBSTART Basic Modularization

Each area of requirements, imposed and inherent, has three subdivisions, one of which in each area is further subdivided, for a total of nine modules. The central issue of space/weight balance is captured by the Arrangement, Volume and Weight modules within Ship Convergence. Together with the definition of hull geometry and ship structures, these five modules summarize the inherent requirements necessary for a design to be a viable submarine. Area and stack length considerations are made in the Arrangement module. The space balance incorporates the requirements of arrangements and volume with a strong connection to the hull geometry. Hull geometry is also a primary factor in the ship's propulsive characteristics. While submerged, the submarine's weight and volume are necessarily related, by the density of seawater. The ship's weight is often dominated by the structure of the hull, but a true understanding of the weight distribution comes from the weights of the systems on board. Figure 11 reiterates this by emphasizing that the majority of non-structural weight, volume and arrangement requirements are made by the payload and propulsive modules.

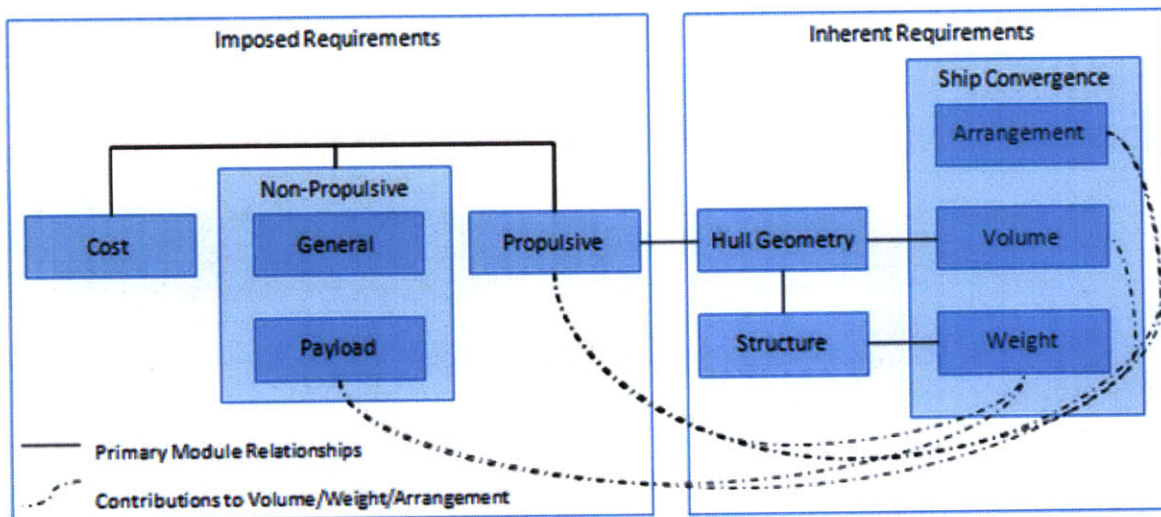

Figure 11 SUBSTART Modularization

The propulsive and payload modules make up half of the imposed requirements. Segmented into cost, propulsive and non-propulsive customer specifications, the imposed requirements section captures the external requirements specific to the design. Payload requirements are of particular interest to the customer, and are therefore afforded their own module, subdividing non-propulsive requirements into payload and general. General non-propulsive requirements may include margins, service life allowance or manning. It is the nature of ship design that the key values that define the design are inextricably linked. Determining which key design values belong in which module is the point on which the five analyzed methodologies diverge.

The level of abstraction provided by modularization may also provide areas of interest which can be addressed by specialized analysis. For example, it is not uncommon to use a standalone cost model or structural analysis tool. While some specialized analyses may go beyond the level of fidelity commensurate with an early stage design (e.g. – finite element analysis), other modules provide those summary analyses which are required for a viable submarine design (e.g. – equilibrium polygon or submerged operating profile). A survey of specialized analyses by module is shown in Table 3.

| Module           | Specialized Analysis   |
|------------------|--|
| Cost             | Cost Model   |
| Non-propulsive   | Primary Customer Interface / Summary of Key Characteristics  |
| Propulsive       | Speed/Power Analysis, Endurance/Operating Profile Analysis, Submerged Operating Envelope, Control Surface Analysis |
| Structure        | Structural Analysis using Parametric Tools or Computer Aided 2-D/3-D Modeling, Finite Element Analysis             |
| Hull Geometry    | Hull Generation using 3-D Modeling Tools and Computer Aided Design, Seakeeping                                     |
| Ship Convergence | General Arrangements, Equilibrium Polygon, Surfaced and Submerged Stability  |

**Table 3 Specialized Analyses by Module**

As mentioned in chapter 2.3, it is optimal that modularization occurs organically from the relationships between design values. While an organic modularization would provide the richest insight into the state of the design, it is cannot be accomplished until the SUBSTART framework is more fully developed and populated. It is appropriate, at this early phase, to impose a nominal modularized view. The modularization describe above is generally useful, but does not have to be the only view of the system of values within SUBSTART. Further modularizations will, and should, form as the relationships between values are defined for a given design. As shown in the comparison of other design methods, a given modularization is only as good as it is helpful to the designer in the context of the specific design and design methodology used. With SUBSTART, the designer is not limited to a single view of the system, but may modularize the design space in any way that provides insight into the design.

## 3.2 Depth of Scope

In order to provide a useful scope, SUBSTART must include values that relate to the breadth of a complete concept design. To ensure that the initial implementation of SUBSTART addresses all areas of a concept design, the MIT SMM was consulted. As stated in chapter 2.1, the MIT SMM is the most complete computational expression of Jackson's works. The variables used within the math model serve as the basis for SUBSTART's list of key naval architecture values. The completeness of the MIT SMM makes it ideal to serve as a starting point, though the assumptions behind the math model will be inherited in the relationships between variables within SUBSTART. For example, some of the MIT SMM calculations use factors that assume U.S. units are used. This overrepresentation of MIT SMM assumptions within SUBSTART will gradually be balanced as alternate calculation methods become available. The list of variables, their units and short descriptions are listed in Appendix A.

Variables used only for intermediate calculations were disregarded if they have no value as a standalone variable (e.g. – array variables used to determine lead location or temporary geometric offsets). Similarly, a short list of variables was added to account variables used in chapter 4.0 by Burcher that do not translate to a variable used in the MIT SMM (e.g. –  $V_{PH-VB}$ , pressure hull volume without volume of the in-hull variable ballast). Tables 4 and 5 list the variables by module for imposed and inherent requirements, respectively.

| Propulsive           |                      | Payload  | General              | Cost       |
|----------------------|----------------------|----------|----------------------|------------|
| AappCdapp            | $\eta_o$             | $KW_i$   | $T_{SW}$             | $CER_{W1}$ |
| $A_s$                | $\eta_{rr}$          | pvf      | $N_{comp\_CPO}$      | $CER_{W2}$ |
| $C_a$                | $v_{SW}$             | pwf      | $N_{comp\_enlisted}$ | $CER_{W3}$ |
| $C_{Ds}$             | PC                   | $r_{sa}$ | $N_{comp\_officer}$  | $CER_{W4}$ |
| $C_f(V)$             | PMF                  | Torpedos | $N_{comp\_T}$        | $CER_{W5}$ |
| $C_{fir}$            | Q                    | TT       | $N_{crew\_CPO}$      | $CER_{W6}$ |
| CT                   | $\rho_{ER}$          |          | $N_{crew\_enlisted}$ | $CER_{W7}$ |
| CT(x)                | $\rho_{RC}$          |          | $N_{crew\_officer}$  | $Cost_C$   |
| $c_{ws}$             | SHP                  |          | $N_T$                | Mdol       |
| $C_{ws}$             | $SHP_{submerged}(V)$ |          | $\rho_{SW}$          |            |
| $c_{wsa}$            | $SHP_{surfaced}(V)$  |          | t                    |            |
| $C_{wsf}$            | $t_1$                |          |                      |            |
| $D_p$                | $V_{goal}$           |          |                      |            |
| E                    | $V_{max\_submerged}$ |          |                      |            |
| $EHP_{submerged}(V)$ | $V_{max\_surfaced}$  |          |                      |            |
| Froud(v)             | $V_{threshold}$      |          |                      |            |
| Froude               | $w_1$                |          |                      |            |
| $\eta_h$             | WS(D)                |          |                      |            |
|                      | $WS_{tot}$           |          |                      |            |

**Table 4 Imposed Requirement Variable Grouping**

| Volume                |                      | Weight                 |                      | Arrangement           |                            | Hull Geometry              |                      | Structure          |
|-----------------------|----------------------|------------------------|----------------------|-----------------------|----------------------------|----------------------------|----------------------|--------------------|
| Err <sub>v</sub>      | V <sub>ER</sub>      | A I <sub>frac</sub>    | LCG <sub>pbm</sub>   | A <sub>bm</sub>       | FF <sub>mud</sub>          | A(x,t)                     | L                    | D <sub>D</sub>     |
| F <sub>Outboard</sub> | V <sub>extra</sub>   | Δ(t)                   | LCG <sub>VL</sub>    | A <sub>cc</sub>       | FF <sub>ops</sub>          | A <sub>wp</sub> (t)        | L <sub>a</sub>       | D <sub>G</sub>     |
| F <sub>Utility</sub>  | V <sub>ff</sub>      | Δ <sub>A</sub>         | NSC <sub>est</sub>   | A <sub>Dopsr</sub>    | FF <sub>rc</sub>           | BM <sub>i</sub> (t)        | LCF(t)               | D <sub>T</sub>     |
| LCB(t)                | V <sub>fffrac</sub>  | Δ <sub>bt</sub>        | VCG                  | A <sub>opsa</sub>     | FMBT1 <sub>aft</sub>       | BM <sub>i</sub> (t)        | L <sub>f</sub>       | f <sub>Frame</sub> |
| LCB <sub>Δc</sub>     | V <sub>fmbt</sub>    | Δ <sub>eba</sub>       | VCG <sub>A</sub>     | A <sub>opsr</sub>     | FMBT1 <sub>frac</sub>      | c <sub>p</sub>             | LOD                  |                    |
| LCB <sub>Δs</sub>     | V <sub>midmbt</sub>  | Δ <sub>ebr</sub>       | VCG <sub>A1</sub>    | A <sub>os</sub>       | FMBT <sub>aft</sub>        | c <sub>pa</sub>            | L <sub>plug</sub>    |                    |
| LCB <sub>ff</sub>     | V <sub>ob</sub>      | Δ <sub>enva</sub>      | VCG <sub>i</sub>     | A <sub>sr</sub>       | f <sub>pway</sub>          | c <sub>pf</sub>            | L <sub>pmb</sub>     |                    |
| LCB <sub>mbt</sub>    | V <sub>opsr</sub>    | Δ <sub>envr</sub>      | VCG <sub>LEAD</sub>  | A <sub>wep</sub>      | H <sub>Deck</sub>          | D                          | MT1(t)               |                    |
| RB                    | V <sub>Payload</sub> | Δ <sub>envsurf</sub>   | VCG <sub>LEADm</sub> | BT <sub>a</sub>       | MUD1 <sub>frac</sub>       | FF <sub>surf</sub>         | θ(x,t)               |                    |
| V(t)                  | V <sub>PH</sub>      | Δ <sub>ff</sub>        | VCG <sub>LEADs</sub> | BT <sub>f</sub>       | MUD <sub>fwd</sub>         | GM <sub>t</sub>            | R(x)                 |                    |
| V <sub>ambt</sub>     | V <sub>PHguess</sub> | Δ <sub>mbt</sub>       | VCG <sub>nsc</sub>   | BT <sub>ops</sub>     | OB <sub>ambt</sub>         | η <sub>a</sub>             | t <sub>envsurf</sub> |                    |
| V <sub>aux</sub>      | V <sub>PH-VB</sub>   | Δ <sub>nsc</sub>       | VCG <sub>VL</sub>    | Deck_Height           | OB <sub>er</sub>           | η <sub>h<sub>f</sub></sub> | TPI(t)               |                    |
| V <sub>bt</sub>       | V <sub>pligr</sub>   | Δ <sub>PH</sub>        | VL <sub>er</sub>     | Decks                 | OB <sub>fmbt</sub>         | I <sub>i</sub> (t)         | trim                 |                    |
| VCB(t)                | V <sub>RC</sub>      | Δ <sub>s</sub>         | VL <sub>ops</sub>    | Dome1 <sub>frac</sub> | OB <sub>mud</sub>          | I <sub>i</sub> (t)         | wl(x,t)              |                    |
| VCB <sub>ff</sub>     | V <sub>s</sub>       | Δ <sub>surf</sub>      | W                    | Dome <sub>aft</sub>   | Ob <sub>ops</sub>          | kb(x,t)                    | WS(t)                |                    |
| VCB <sub>MBT</sub>    | V <sub>sa</sub>      | Δ <sub>surfest</sub>   | W <sub>1frac</sub>   | ER1 <sub>fwd</sub>    | OB <sub>rc</sub>           | KM <sub>envsurf</sub>      | wsa(x,t)             |                    |
| V <sub>d</sub>        | V <sub>tot</sub>     | Err                    | W <sub>4frac</sub>   | ER <sub>aft</sub>     | OPS <sub>fwd</sub>         | KM <sub>nsc</sub>          |                      |                    |
| V <sub>Dopsr</sub>    | V <sub>VB</sub>      | Error <sub>VB</sub>    | W <sub>5frac</sub>   | ERAFT <sub>frac</sub> | OPSFWD <sub>frac</sub>     |                            |                      |                    |
| V <sub>eba</sub>      | V <sub>VBact</sub>   | FS <sub>corr</sub>     | W <sub>6frac</sub>   | ER <sub>fwd</sub>     | RC <sub>fwd</sub>          |                            |                      |                    |
| V <sub>ebr</sub>      | V <sub>VL1</sub>     | K3                     | W <sub>7est</sub>    | ERFWD <sub>frac</sub> | RCFWD <sub>frac</sub>      |                            |                      |                    |
| V <sub>envr</sub>     |                      | KG <sub>envsurf</sub>  | W <sub>d</sub>       | Err <sub>OPSarr</sub> | Stacklength <sub>er</sub>  |                            |                      |                    |
|                       |                      | LCG                    | W <sub>i</sub>       | f <sub>Curve</sub>    | Stacklength <sub>ops</sub> |                            |                      |                    |
|                       |                      | LCG <sub>A</sub>       | W <sub>PB</sub>      | FF <sub>ambt</sub>    | Stacklength <sub>rc</sub>  |                            |                      |                    |
|                       |                      | LCG <sub>A1</sub>      | W <sub>pbfr</sub>    | FF <sub>er</sub>      | x                          |                            |                      |                    |
|                       |                      | LCG <sub>envsurf</sub> | W <sub>PBfrac</sub>  | FF <sub>fmbt</sub>    |                            |                            |                      |                    |
|                       |                      | LCG <sub>i</sub>       | W <sub>pbm</sub>     |                       |                            |                            |                      |                    |
|                       |                      | LCG <sub>LEAD</sub>    | W <sub>pbs</sub>     |                       |                            |                            |                      |                    |
|                       |                      | LCG <sub>LEADm</sub>   | W <sub>VL</sub>      |                       |                            |                            |                      |                    |
|                       |                      | LCG <sub>LEADs</sub>   | W <sub>vifr</sub>    |                       |                            |                            |                      |                    |
|                       | LCG <sub>nsc</sub>   | W <sub>VLfrac</sub>    |                      |                       |                            |                            |                      |                    |

**Table 5 Inherent Requirement Variable Grouping**

First impressions show a mismatch with propulsive, hull geometry and ship convergence modules having a much greater number of values than does the non-propulsive, cost and structure modules. The seeming mismatch in depth of detail of each module actually reinforces the known in focus in the design methods. The MIT SMM is more robust at estimating propulsive power and converging the weight/space balance of the design. Likewise, cost and

structure analyses have traditionally been conducted with supplementary models. The relationships in these supplementary models are prime additions to add into the SUBSTART list of values in later stages of development. Cost estimating ratios (CERs) and crew complement accounting ( $N_{\text{comp\_enlisted}}$ , etc.) variables were added to the list to show the ease of integration of further variables into the SUBSTART framework.

The lack of detail in the non-propulsive requirements module highlights the MIT SMM's assumption that the most important effects from these requirements will be accounted for in the weight and area estimates. Improving the fidelity of general and payload related customer specifications is another area that would be helped by additional values. Improvement in fidelity of requirements would make the design tool more flexible and more accessible to a designer that possessed input information in that format. This assumes that the relationships between the additional and existing values are known and are therefore able to be coded.

## **3.2 Framework**

The true benefits that SUBSTART attempts to achieve stem from a transparent, “apples-to-apples” view of the description and interactions between the key naval architecture values chosen above. This transparency is achieved via the open architecture framework of SUBSTART. The framework uses a general data structure to describe variables, show the options regarding their calculation and linking them to other variables and to historic data.

### **3.2.1 Data Structure**

The core of SUBSTART is the list of naval architecture values, each presented in their own instance of the generic SUBSTART data structure. The facets required of a useful data structure were introduced in chapter 2.2. Figures 12 and 13 are used to describe how the general SUBSTART data structure addresses these facets: chosen value, its units, calculation options and

their calculated values, formulas or design lanes and relevant notes. Interaction between variables is discussed in chapter 4.0.

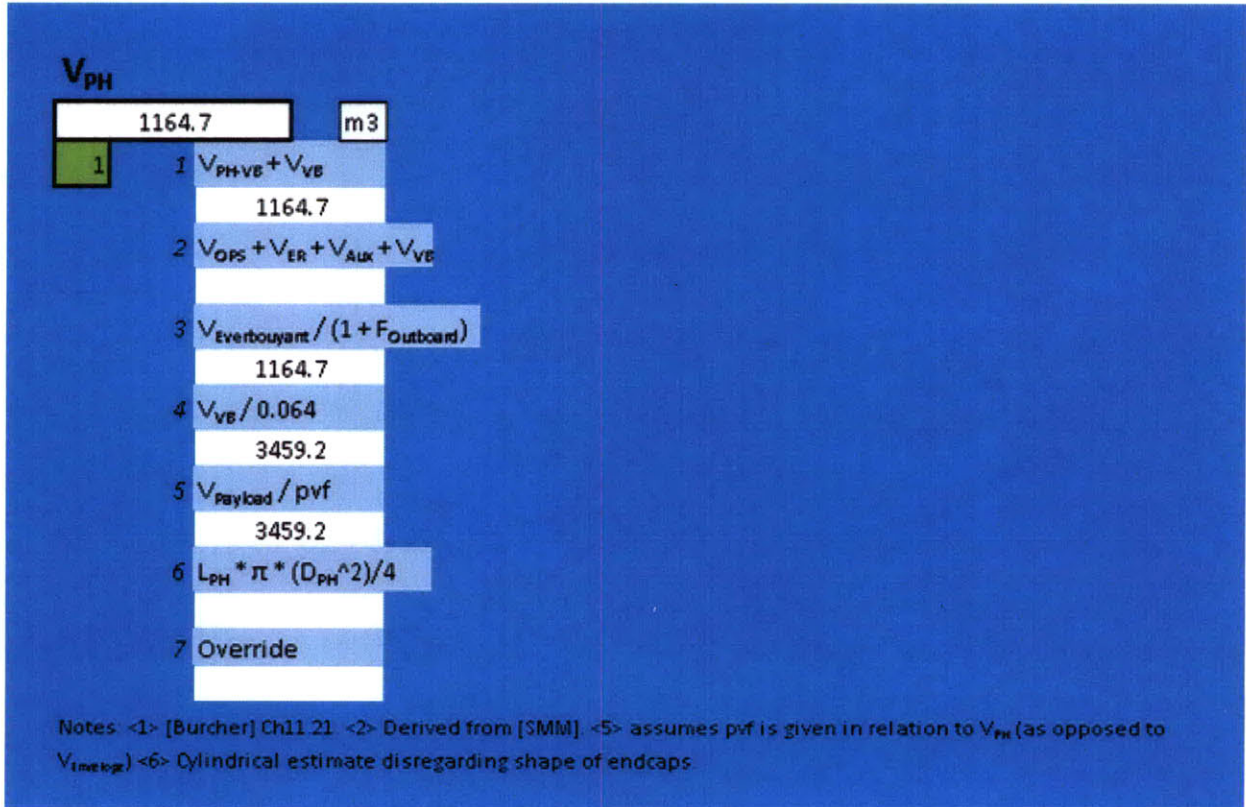

Figure 12 Data Structure Example –  $V_{PH}$

Figure 12 shows the data structure associated with calculating pressure hull volume,  $V_{PH}$ . Figure 13 shows one of the values used in Burcher’s walkthrough of first-pass estimation of ship volumes (Burcher, Ch.11; UCL, 18). The payload volume fraction, denoted pvf, is a value that may be used in calculation of payload volume,  $V_{Payload}$ . Currently, seven options are available for how to calculate  $V_{PH}$ . The currently promoted calculation is option one, summing the volume of variable ballast,  $V_{VB}$ , with the volume of the pressure hull without variable ballast volume,  $V_{PH-VB}$ , as calculated in chapter 11 of Concepts in Submarine Design, resulting in 1164.7 cubic meters. Figure 13 provides a look at each component of the data structure.

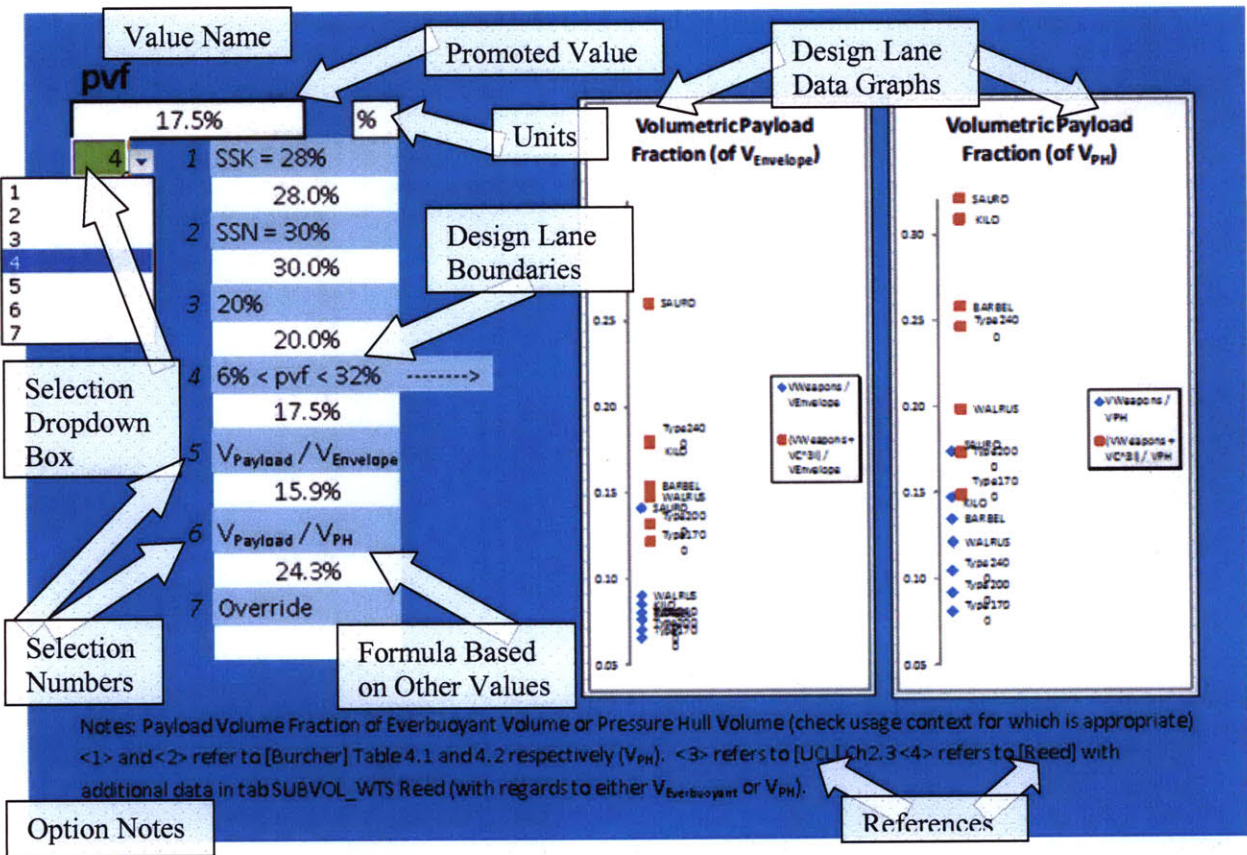

Figure 13 SUBSTART Data Structure Labeled Example – pvf

Figure 13 shows that seven options also happen to be available to find a value for pvf. Other options may be added as other methods are integrated in SUBSTART. The method that is chosen to be promoted is selected via a dropdown box directly below the promoted value. This is the value that is used by other variables when pvf is included in a calculation. To the right of each selection number is the formula used for that calculation method. Directly below the formula is the calculated value.

Further notes for a given method are found at the bottom of the structure, designated by the selection number in angle brackets. References within the method notes, consistent with the bibliography in this paper, are designated by brackets. The note area is useful to provide the designer with background or usage information when needed to fully understand the implications

of selecting a particular method. This information may simply be a reference to the source of the formula, or may relate the assumptions behind the calculation in a further explanation of the circumstances in which the method is appropriate to use. The notes area may also be used to relate relative confidence levels of the calculations' results.

Every key naval architecture value in SUBSTART has an option to directly enter a value, called the override value, option 7 in the case of pvf. The override value may be used to input precise values that are developed in a 3-D modeling tool or simply an estimate by the designer to begin calculations. Formulas that are based on other values, such as options 5 and 6 of Figure 13, are automatically updated based on the promoted value of the variables used in the formula. Options 1, 2 and 3 for pvf are single data points gathered from the sources listed in their notes section. Option 4 references design lane extreme values. To the right of the method formulas are graphs that show the referenced design lanes. Other graphical views of historic data, or of user data developed in another section of SUBSTART, may be displayed in this area. In the current implementation of SUBSTART, double clicking on a graph will change the designer's view to the historical data used to develop the graphs. The data spreadsheet data used to create the above graphs is shown in Figure 14.

### **3.2.2 Supplementary Tables**

Supplementary tables within SUBSTART take two forms: data tables and supplementary modules used for more detailed calculations or accounting. Knowledge capture is not only accomplished through the collection of formulas, but also in the collection of historic data available for immediate presentation via design lanes. This data is maintained in supplementary data tables, in secondary spreadsheets within SUBSTART. If the design lanes provided do not address the material in quite the way the designer is looking for, the base data is available for further analysis. Other views, graphs, charts, etc. may be developed from the data resident in SUBSTART as they are found to be useful.

Beyond tables of raw historical data, other useful types of information may be compiled in supplementary spreadsheets within SUBSTART. This is a useful way to store information such as lists of equipment specifications, or to provide secondary modules that conduct calculations outside of the mainstream of SUBSTART's list of key naval architecture values. For example, a payload equipment selection module may provide a list of equipment from which to choose, conduct the accounting of weights, volumes, centroid locations, etc. and provide the results to be used as an override value within a related SUBSTART data structure. Detailed cost module calculations, mission profile descriptions, electrical power accounting and appendage calculations are all good candidates for subsidiary spreadsheet calculations.

Supplementary calculations do not only have to occur on spreadsheets within SUBSTART. Values may be transferred to and from other design tools, such as PARAMARINE, or any other program that has an Excel application programming interface, or API. This allows for precise data developed during 3-D modeling to be transferred into SUBSTART. It also allows for key

naval architecture values, developed as a first pass through the design in SUBSTART, to be ported into PARAMARINE for further design work.

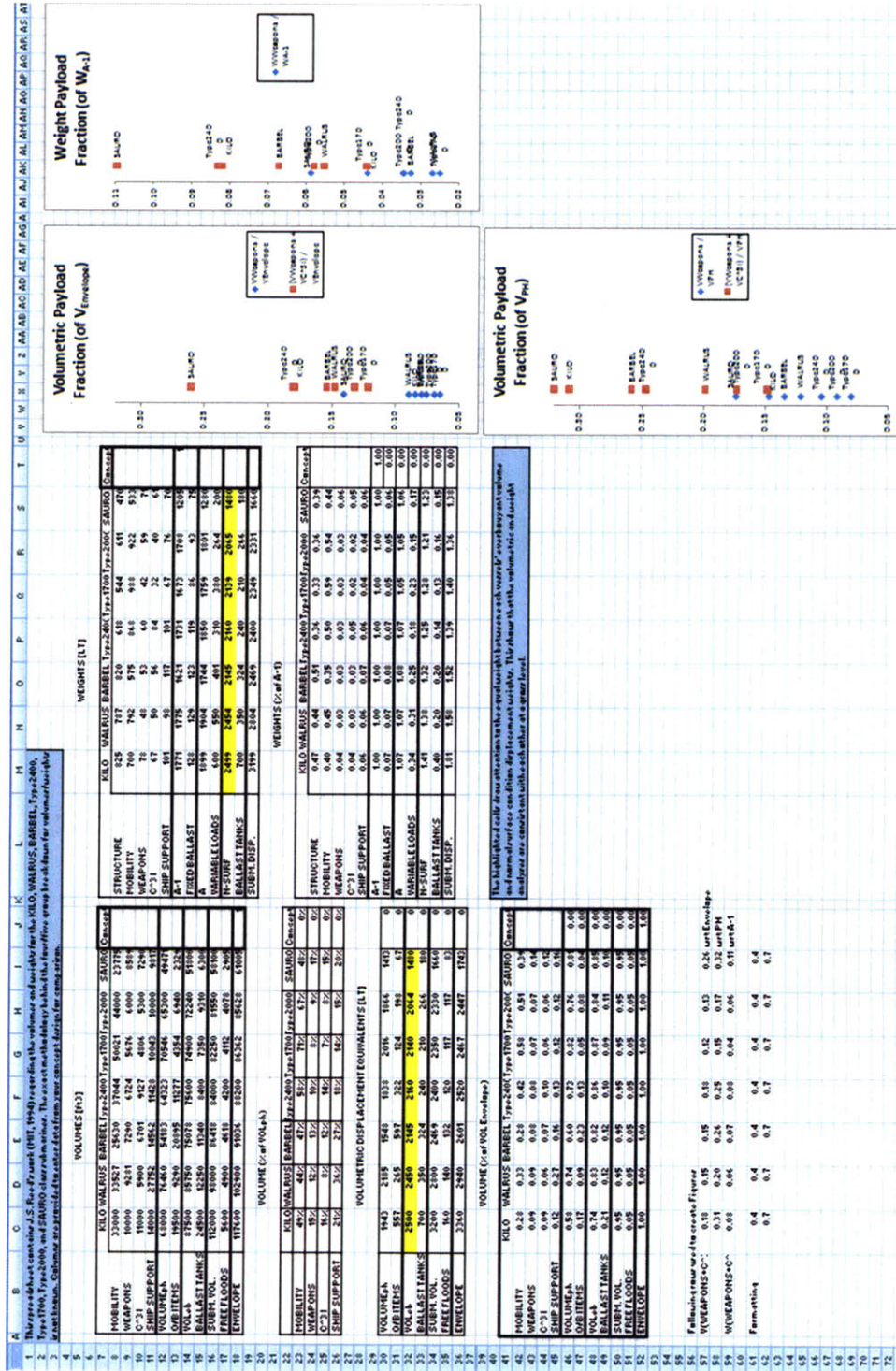

Figure 14 SUBSTART Data Table Example

## 4.0 Walk-Through

This chapter presents a walkthrough of SUBSTART following the development from payload volume,  $V_{\text{Payload}}$ , to envelope volume,  $V_{\text{Envelope}}$ , described in chapters 11.19 through 11.21 of Concepts in Submarine Design (Burcher), referenced in Figure 15. Appendix B contains further detail for all key naval architecture values discussed in this section, presented in their data structure views. This chapter instead uses a graphical view to present the relationships between values. The walkthrough concludes with an alternate scenario where the designer starts from a different set of initial information available.

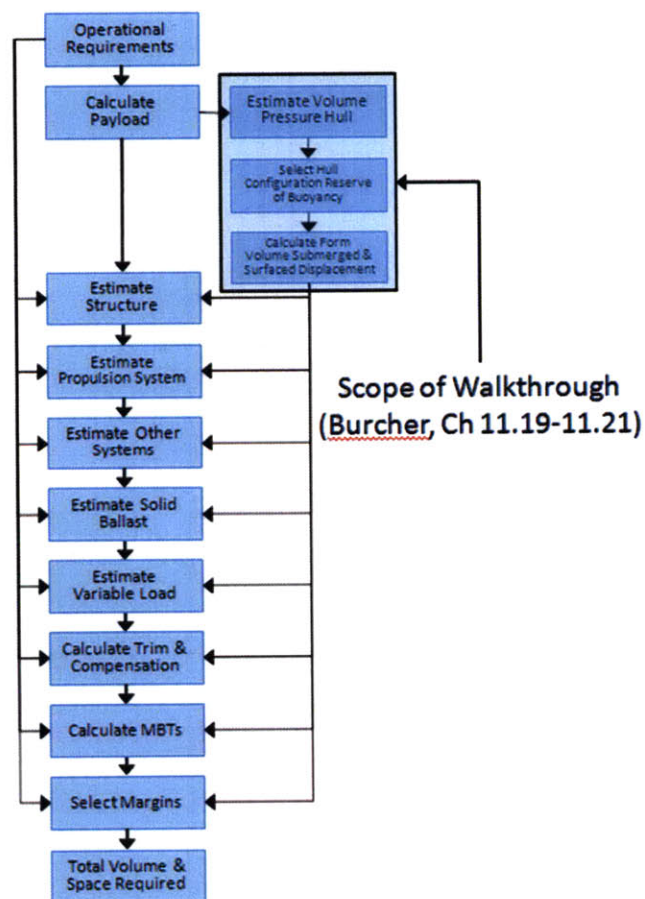
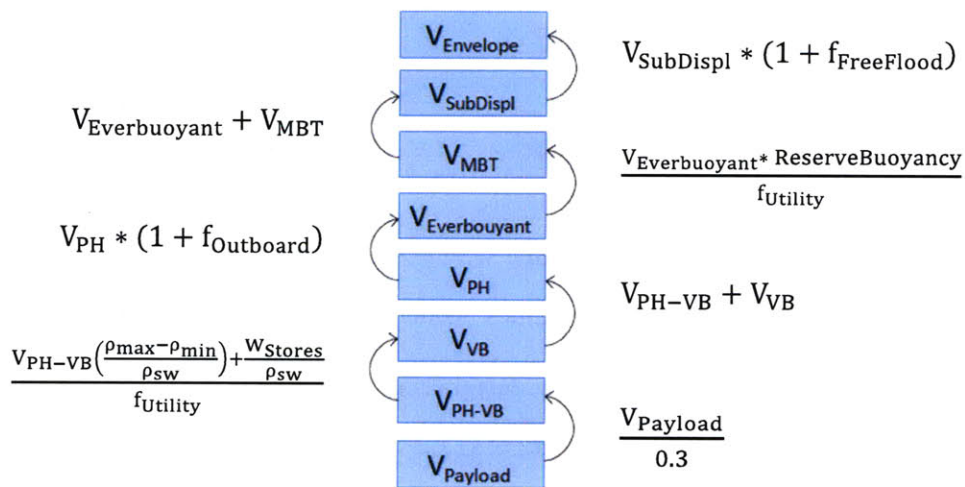

Figure 15 Scope of Walkthrough

Chapter 11 of Concepts in Submarine Design, entitled “Generating a Concept Design,” includes a walkthrough of the beginning stages of a concept design, starting in section 11.19 with  $V_{\text{Payload}}$  and ending in section 11.31 with pressure hull structural weight (Burcher). For this walkthrough, only the first portion of calculations will be considered. The transition from  $V_{\text{Payload}}$  to  $V_{\text{Envelope}}$  is straightforward, as displayed in Figure 16 with the associated equations to move from one key naval architecture value to the next. In Figure 16 through Figure 19 each block represents a key naval architecture value and each connecting line represents a relationship between values codified by an equation.



**Figure 16 Calculations from  $V_{\text{Payload}}$  to  $V_{\text{Envelope}}$  (Burcher)**

Burcher’s development of  $V_{\text{Envelope}}$  is a streamlined set of estimates, provided the designer has an estimate of  $V_{\text{Payload}}$ . Further complexity enters as the designer considers the variables that are required to transition between the key naval architecture values of interest.

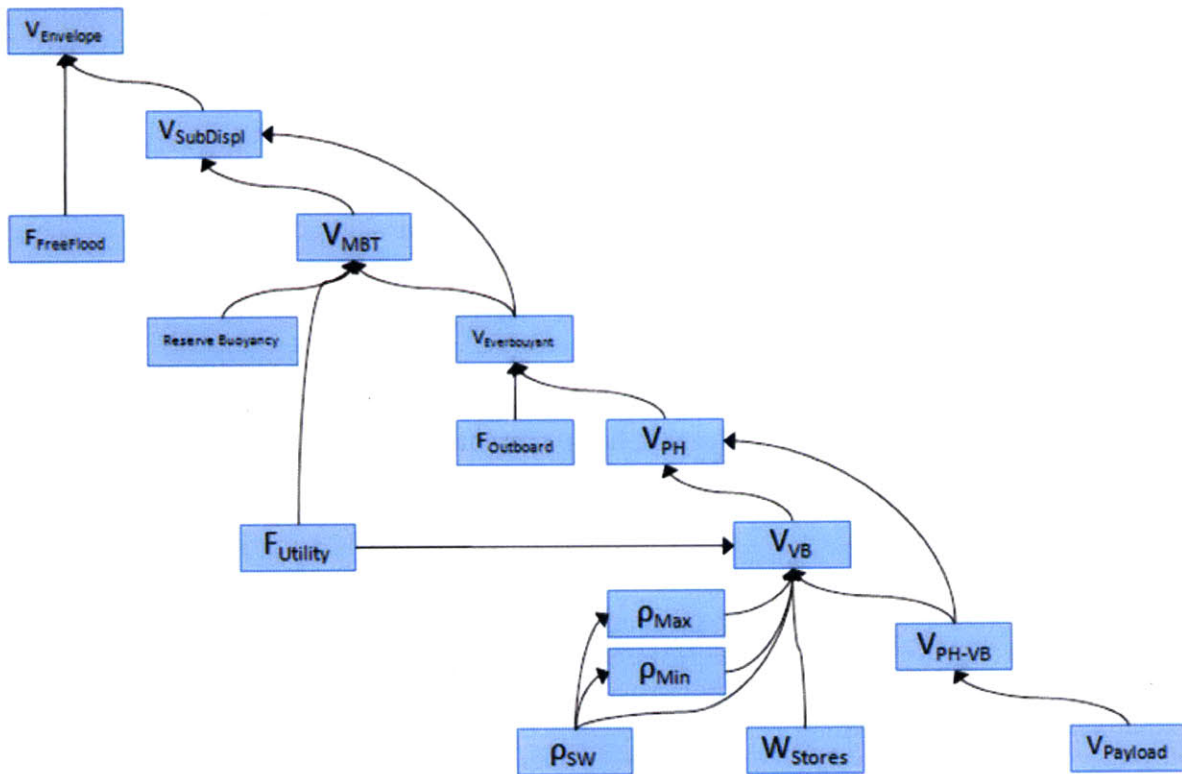

**Figure 17 Primary and Secondary Values**

Figure 17 graphically displays the other eight values needed to complete the required calculations. The total pieces of information the designer requires is now nine:  $V_{Payload}$ ,  $W_{Stores}$ ,  $\rho_{sw}$ ,  $\rho_{max}$ ,  $\rho_{min}$ ,  $f_{Utility}$ ,  $f_{Outboard}$ ,  $f_{FreeFlood}$  and Reserve Buoyancy. The designer must now branch out beyond the equations presented by Burcher in Figure 16 to determine  $V_{Envelope}$  and the volumes leading up to it. Table 6 presents the number of calculation options available for the original set of volumes, Figure 16, including override values and the equations used by Burcher. SUBSTART, as implemented in Appendix B, provides individual instances of the SUBSTART data structure for each of the sixteen key naval architecture values in Figure 17 as well as for a number of other values that may be used to calculate them.

| Key Naval Architecture Value | Number of Calculation Methods in SUBSTART |
|------------------------------|---|
| $V_{Envelope}$               | 5   |
| $V_{SubDisp}$                | 5   |
| $V_{MBT}$                    | 4   |
| $V_{Everbuoyant}$            | 6   |
| $V_{PH}$                     | 7   |
| $V_{VB}$                     | 4   |
| $V_{PH-VB}$                  | 3   |
| $V_{Payload}$                | 6   |

**Table 6 Number of Calculation Options in SUBSTART**

Figure 18 graphically presents the values that are coded into SUBSTART and each of the relationships that are coded as calculation options. Solid lines represent the calculations selected by the designer. All methods selected to this point follow the Burcher design methodology above. Dashed lines represent unselected calculation methods.

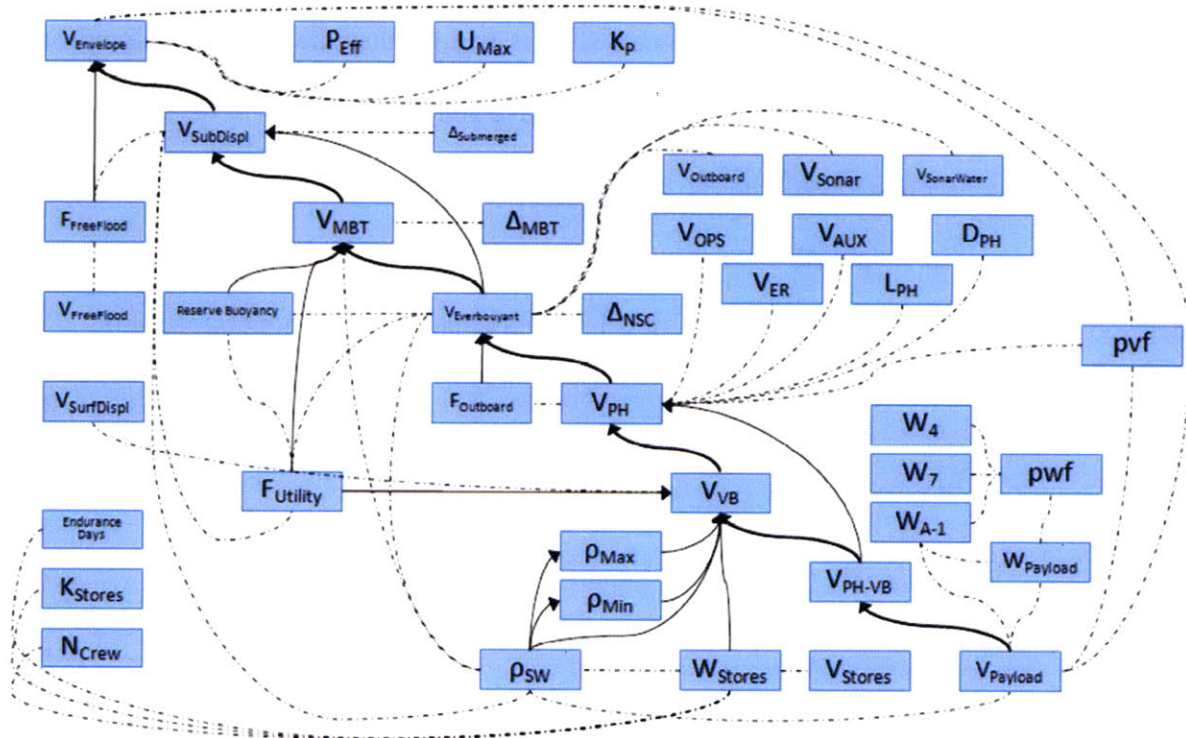

**Figure 18 Primary and Related Values**

The system of values quickly increases in complexity as alternate calculation methods are considered. If calculation options were entered and graphed for all values, the complexity would be overwhelming. In Figure 16, all variables were confined to the volume module, categorizing the variables according to the SUBSTART modularization discussed in chapter 3.1. By Figure 18, interactions are becoming apparent for variables from the volume module with variables from the weight, hull geometry, propulsive, general and payload requirement modules.

The interwoven nature of ship and submarine design is graphically evident, demonstrating the need for modular views of the design space. At the data structure level, SUBSTART's strength is in capturing the possible relationships between particular key naval architecture values. This enables the designer to make individual decisions in a more informed manner, but the data structure view is not as powerful as a graphical view to explore alternate design development ideas. To be useful, the graphical view must be intuitive and representative of the decisions made in the data structure view. The current implementation of SUBSTART does not support dynamically updating graphical views due to the limitations of Excel. Figure 19 shows the development of the volumes from Figure 16 using an alternate set of starting information.

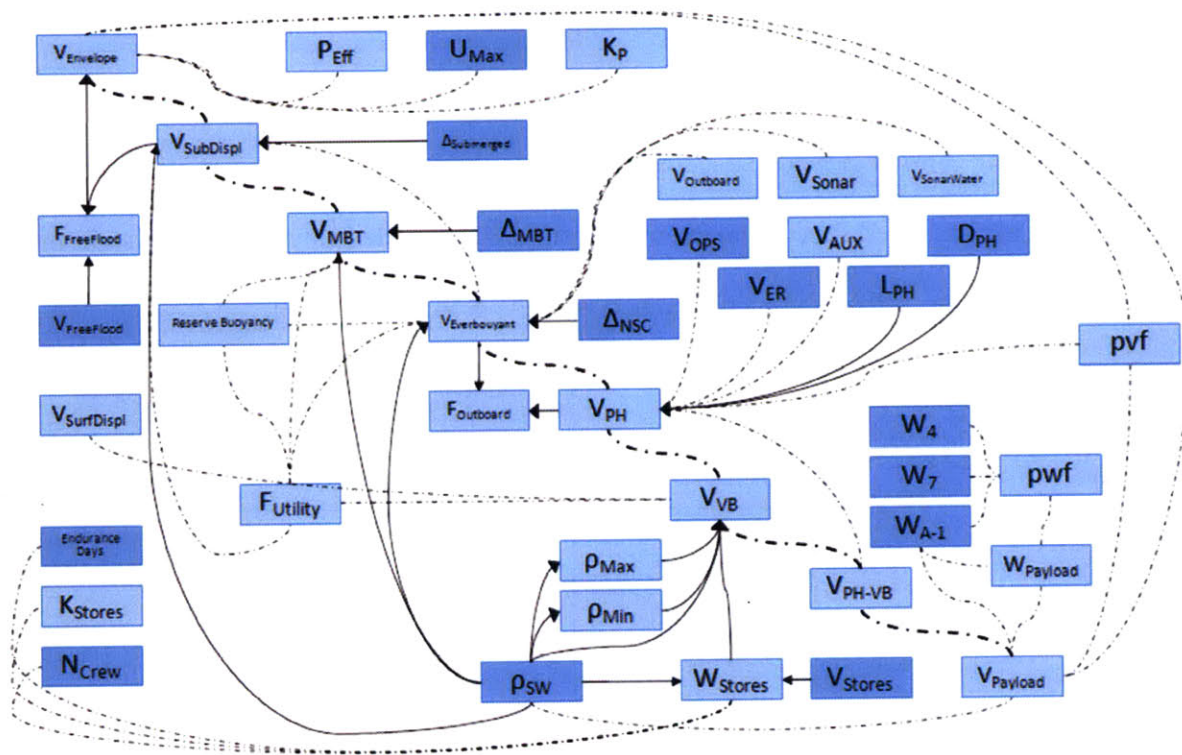

Figure 19 Alternate Configuration – Primary and Secondary Values

In the alternate scenario, the initially known values are designated by darker shading in Figure ABOVE. The known values in this scenario nominally come from customer requirements ( $U_{max}$ ,  $N_{Crew}$ , Endurance Days,  $\rho_{sw}$ ), a basic cartoon ( $D_{PH}$ ,  $L_{PH}$ ,  $V_{OPS}$ ,  $V_{ER}$ ,  $V_{Stores}$ ,  $V_{FreeFlood}$ ) and initial weight estimates ( $W_4$ ,  $W_7$ ,  $W_{A-1}$ ,  $\Delta_{NSC}$ ,  $\Delta_{MBT}$ ,  $\Delta_{Submerged}$ ). Using these initial values, numerous other values were able to be determined. Table 7 lists the key naval architecture values that are developed from the initial known values, designated as first pass variables. For example,  $V_{PH}$  is a first pass value developed from  $L_{PH}$  and  $D_{PH}$ . Second pass values are values that are developed from a combination of initially known and first pass values, and so on. Continuing the example,  $f_{Outboard}$  is a second pass variable developed from  $V_{PH}$  and  $V_{Everbuoyant}$ .

By using the collection of different methods found in SUBSTART, twenty two values are calculated after four passes, including two calculation methods for  $V_{VB}$  that can be compared to

each other for consistency. After five passes, a secondary calculation for  $V_{PH}$  is available to compare against the initial cylindrical estimation. This comparison may expose inconsistencies in the originating cartoon or lead to a change in pressure hull length or diameter. If the fifth pass value of  $V_{PH}$  is considered superior to the initial estimate, all related calculations of the design are updated when the fifth pass calculation becomes the promoted method.

| First Pass   | Second Pass  | Third Pass   | Fourth Pass  | Fifth Pass                                 |
|--|--|--|--|--|
| From Known Values  | From Known and First Pass Values   | From Second Pass and Previous Values   | From Third Pass and Previous Values  | From Fourth Pass and Previous Values       |
| $W_{Payload}$<br>$pwf$<br>$W_{Stores}$<br>$V_{PH}$ (cylindrical approximation)<br>$V_{Everbuoyant}$<br>$V_{MBT}$<br>$V_{SubDispl}$<br>$\rho_{max}$<br>$\rho_{min}$ | $V_{Payload}$<br>$V_{Aux}$<br>$K_{Stores}$<br>$f_{outboard}$<br>$f_{utility}$<br>$f_{freeflood}$ | $pvf$ (using $V_{PH}$ and $V_{Payload}$ )<br>$V_{PH-VB}$<br>$V_{Outboard}$<br>Reserve Buoyancy<br>$V_{Envelope}$ | $pvf$ (using $V_{Envelope}$ and $V_{Payload}$ )<br>$V_{VB}$ (Using $V_{PH}$ and $V_{PH-VB}$ )<br>$V_{VB}$ (Using $V_{PH-VB}$ , $W_{Stores}$ , $\rho_{sw}$ , $\rho_{max}$ and $\rho_{min}$ )<br>$P_{Eff}$ (using $K_p$ from SUBSTART) | $V_{PH}$ (using $V_{VB}$ and $V_{PH-VB}$ ) |

**Table 7 Values Developed - Alternate Scenario**

SUBSTART is a powerful knowledge capture tool, as seen in chapter 3. But a collection of equations and supporting data is only useful if the designer can navigate the information, apply it and understand the resulting implications. Those implications are illuminated by walking through the example of developing Burcher's initial volume estimates. Through the use of a graphical view, it is easily seen how complex the interactions between variables can become once multiple design methods are considered. Therefore, a useful modular view is required to keep the system of variables and relating equations from becoming overwhelming.

Having multiple design methods available also brings advantages that cannot be gained otherwise. A designer may find that the information that is available at the beginning of the design does not match the prerequisite information assumed by a given design methodology. By providing several calculation options, SUBSTART may provide other ways to develop the desired set of key naval values from otherwise unorthodox means. The designer can gain further insight into a design as the information becomes available to calculate a value by multiple methods. With multiple calculated values, the designer can validate methods against each other, choose between methods based on their underlying assumptions or confidence of supporting values, or choose to make an informed interpolation.

In the case that a desired value is unable to be calculated, SUBSTART allows the designer to better estimate values by providing a wealth of historical data in design lanes or alternate graphical forms. If the available design lanes do not present the information in a way that is beneficial, the information itself is accessible for in-depth analysis.

## **5.0 Conclusions**

### **5.1 Motivation**

Naval architecture is a broad field of study that covers many areas of specialty. This is one reason that ship and submarine design is a difficult problem. Not only do multiple fields of expertise challenge the ship designer, but the design space is composed of a tightly woven web of interrelated variables. To overcome this complexity, effective design methodologies have been developed spanning the many years, nationalities and advances in the field. Each modern methodology has grown out of its respective tradition, bringing diversity to address the problem of submarine design. This richness of approach is not easily exploited by a designer, due to the scope of their training within a particular design tradition. While the majority of submarine design principles is common across the field, disparate design traditions bring differing assumptions, approaches and parametrics to bear.

The goal of SUBSTART is to aid the designer, and advance the field of early stage submarine design, by providing a framework to capture a broad range of this knowledge, in the form of equations, data and explanations of assumptions, and present that information in a manner that enhances the design process. The method SUBSTART uses to achieve these goals is reviewed, followed by a summary of benefits and weaknesses of the current implementation of SUBSTART. This discussion leads to consideration of areas to improve and apply the tool.

### **5.2 Method**

The SUBSTART framework is designed for two primary goals: knowledge capture and useful presentation of information. To understand the knowledge capture function SUBSTART could provide, a survey of current design methodologies was required. The survey revealed numerous

similarities across a variety of design methods, as well as notable differences among methodologies. The similarities illuminate the core competencies and key naval architecture values that are an integral part of early stage submarine design. The differences reveal various ways of looking at the design problem.

By gathering and presenting these differences for each key naval architecture value, SUBSTART is able to better inform the designer of calculation options. To enhance ease of use and ease of updatability, a generic data structure was developed that is able to present the equations, assumptions and data graphs for each key naval architecture value. The template, shown in Figure 20, is instanced for each variable. New additions to the SUBSTART list of variables simply create a new instance of the data structure template.

| Value Name |   | Promoted Value                | Units |
|------------|---|-------------------------------|-------|
| 1          | 1 | First Formula                 |       |
|            |   | Calculated Value              |       |
|            |   | Further Formulas as available |       |
|            | 3 | Third Formula                 |       |
|            |   | Third Value                   |       |
|            | 4 | Add more rows as required     |       |
|            | 5 | Override                      |       |

Area for design lanes or other graphical representation of related data.

Area for notes to provide explanation or other information about calculation methods.

Figure 20 SUBSTART Data Structure Template

While the core of SUBSTART is presented in the collection of data structures for each key naval architecture value, other facets of SUBSTART are just as important. Supplementary spreadsheets are also available for user viewing and updating. While equations and assumptions are cataloged with the data structure, the raw data that is used to create design lanes and other

data graphs are resident in supplementary spreadsheets. Other supplementary spreadsheets are specialized modules that contain calculations more complex than variable-to-variable equations contained in the data structure. Together, the data structure and supplementary spreadsheets support five major facets of knowledge capture:

- capturing equations,
- capturing data,
- capturing assumptions and other notes,
- capturing other processes in specialized modules, and
- providing ease of updatability.

Detailed presentation of this information is resident in the data structure and supplementary spreadsheets as discussed above, but there is also a need for presentation of the information at a higher level of abstraction. Two views that are essential to the designer address the relationships between key naval architecture values. Modular grouping of the values and summarization of the equations relating the values lend a level of intuition to the design process and provide a basis for innovative analysis of the design. Summarization of equations may be represented in various ways depending on the insights the designer is seeking. For example, a flowchart view can graphically present current and possible calculation methods, or a list of values might be filtered by the method of calculation, such as methods from the MIT SMM or those values that promote the override field. To be of maximum utility, the modularization and summary views should dynamically update to represent the state of the design as defined by the decisions the designer has made in the data structure view.

### **5.3 Observed Benefits and Weaknesses**

By providing an easily updatable and flexible knowledge capture tool, the SUBSTART framework encourages early stage submarine designers to question their assumptions through comparisons with less familiar methodologies. Provision is provided to further investigate options that would otherwise be unavailable to the designer. Through the use of multiple calculation options, values may be obtained in scenarios that may otherwise force the designer to resort to estimation instead of a more precise calculation. In cases where estimation must occur, historical data is presented to the designer to in either a beneficial graphical form or in its unmanipulated form.

As a given design progresses, information may come available that enables key naval architecture values to be calculated in more ways. As multiple calculation options arise, their results can be compared for validation or the value can be updated based on the new information. The decision to update may be based on greater fidelity of the calculation method itself, greater confidence in the values involved in the calculation or a greater level of appropriateness for the given design regarding the assumptions of the design methodology behind the calculation method.

Updates in calculation method cause the key naval architecture values to be actively related to each other in new ways. Graphical views of this interconnectivity may provide insights into which areas of the design are most closely related, or which areas lack confidence, or which variables require further investigation due to their importance. More insightful modularizations may form out of these shifting relationships, providing insight into the unique properties of the given design.

SUBSTART might be used as a starting point for the designer to get a “first-pass converged design” before moving to another higher fidelity design tool. For example, the promoted values of selected key naval architecture values could be imported into the PARAMARINE design tool to enable 3-D design modeling. This functionality can also work in reverse, allowing precise modeling data to be imported into SUBSTART to improve the confidence of related calculations. This reciprocity is also found in between variables of SUBSTART. The lack of a structured order of operations enables the designer to “calculate in either direction,” subject to the validity of the particular equation.

These benefits come at the cost of either ease of use or complexity of implementation. The current implementation of SUBSTART uses Microsoft Excel. The current data structure view is not particularly user friendly, but should become more intuitive as more data and calculation methods are coded into SUBSTART. Organization of, and navigation between, key naval architecture values is severely lacking, making navigation and review cumbersome. Excel is unable to support the graphical dynamic updates required to create the modularization and flowchart style graphical views described above. This is a significant limitation, as SUBSTART loses the ability to present the designer with high level insights into the design. This graphical capability may be able to be created within an external programming application, such as Visual BASIC or MATLAB.

The potential size of the SUBSTART database is not well suited for Excel. The current implementation of SUBCODE uses approximately one hundred Excel workbooks to accommodate data, user interfaces and subroutine calculations. Later implementations of SUBCODE are planned to use another application to avoid the lag and memory issues that occur when the tool is scaled to such extreme sizes within the Excel environment. The size of

SUBSTART, when fully implemented, would exceed the size of SUBCODE, due to the encompassing nature of SUBSTART's goal of knowledge capture. Both finding an application environment that can handle such a large program and the act of populating such a large data space are very significant issues. The issue of populating SUBSTART is the largest impediment to creation of a fully operational design tool.

The lack of a structured order of operations, combined with many paths of interconnectivity between key naval architecture values, makes the possibility of circular reasoning a potential problem. Any implementation of SUBSTART should provide checks to prevent, or warn, against circular reasoning. Excel does provide limited functionality in this regard, but the designer may not realize the circular reasoning exists until all of the calculations in question are chosen for promotion.

## **5.4 Areas of Improvement and Application**

The goals of SUBSTART are to provide improved decision making through knowledge capture, and innovation through improved decision making. There are numerous areas of improvement that would help SUBSTART achieve these goals. There are also a number of interesting applications that SUBSTART could enable to advance the field of early stage submarine design. The most pressing areas of improvement and most interesting areas of application are discussed below.

### **5.4.1 Areas of Improvement**

The most pressing issues facing SUBSTART are in the areas of user interface, viewing options and data population. The user interface requires improvements beyond those afforded by dynamically updating graphical view capability. The data structure view requires an overhaul its organization and navigation system. Calculation selections and design overview analysis would

both be significantly improved if numeric tracking of confidence was available. Confidence level tracking could provide an objective optimization method to the design process, though not to the design itself.

Effective views are the only way to leverage wealth of data within SUBSTART. Because every set of design requirements is different, the ability to view relevant information in a customizable way is important. Customization of viewing options may include the ability to filter the data or key naval architecture values that are presented based on a variety of determinants. This is one example of controlling the level of detail presented to the designer. SUBSTART is meant to be a transparent tool, but usability could be hindered if the designer must work through the highest level of detail in all circumstances. Easing the transition between levels of detail and other viewing options could be achieved through the use of profile settings.

The most important improvement to the current SUBSTART framework is its instantiation from a framework into a design tool. The current implementation of SUBSTART could be a useful tool without any other improvements if only it was populated with relevant data. That data is found in the form of equations, raw and formatted data, the assumptions and explanations behind their use and development, and the capture of more detailed processes in specialized modules.

Table 8 summarizes the discussed areas of improvement and provides examples of data with which to populate SUBSTART.

|                 |   |
|-----------------|---|
| User Interface  | <ul style="list-style-type: none"> <li>• Dynamically update graphical summary views <ul style="list-style-type: none"> <li>○ Flow charts</li> <li>○ Modular summary</li> </ul> </li> <li>• Improve organization of, and navigation between, values in data structure view</li> <li>• Provide areas in the data structure for numeric tracking of confidence level in individual calculations <ul style="list-style-type: none"> <li>○ Allow statistical analysis of confidence levels of values in the design based on promoted values</li> <li>○ Provide analysis of potential confidence levels based on non-promoted values for comparison</li> </ul> </li> </ul>  |
| Viewing Options | <ul style="list-style-type: none"> <li>• Ability to filter summary views <ul style="list-style-type: none"> <li>○ Filter by module, variable type, source design methodology, confidence level, etc.</li> </ul> </li> <li>• Provide views with various levels of detail <ul style="list-style-type: none"> <li>○ Adjust detail level either globally or locally</li> </ul> </li> <li>• Enable global and local unit conversion</li> <li>• Support profile viewing to easily change between viewing options</li> </ul>   |
| Data Population | <ul style="list-style-type: none"> <li>• Equations from various design methodologies <ul style="list-style-type: none"> <li>○ Development of key naval architecture values, or analysis values such as the Admiralty Constant (Gabler, 37)</li> </ul> </li> <li>• Data <ul style="list-style-type: none"> <li>○ Data that supports equations (Jackson, “Submarine Design Trends”)</li> <li>○ Raw naval architecture data (Jane’s, Interavia)</li> <li>○ Equipment lists and specifications such as diesel or battery specifications</li> <li>○ Formatted naval architecture data (Torkelson)</li> <li>○ Specialty area data such as AIP (Thornton)</li> </ul> </li> <li>• Supplementary Spreadsheets <ul style="list-style-type: none"> <li>○ Specialized calculations or accounting such as Mission Profile, Structural, AIP Sizing or Electrical Loading Modules</li> </ul> </li> </ul> |

Table 8 SUBSTART Potential Improvements by Area

### 5.4.2 Areas of Application

SUBSTART has great potential to be utilized within a greater context. Its ability to easily change calculation methods based on the set of information available at a given point in design makes SUBSTART a potentially powerful tool to be used in set based design. SUBSTART is suited to act as an early stage design space exploration tool if paired with an effective manipulation script. Such a script may also provide the ability to analyze ranges of values, as opposed to single point values. The ability to analyze ranges of output based on updatable measures of effectiveness is another powerful capability that aligns well with the philosophy of SUBSTART.

SUBSTART would provide a wealth of process information within a given design and across multiple designs, assuming the dynamically updatable summary functionality is operative. This type of process information, developed by the relationships chosen within the design, is fertile ground for analysis of early stage submarine design information flow. Possibilities for analysis include the use of a design structure matrix, or DSM, to analyze and optimize the information flows of various types of submarine designs. This analysis could lead to more beneficial modularization options that could be used in further early stage submarine designs.

To promote synergy between many design entities, SUBSTART could be implemented as a distributed application. Integration of input from multiple designers and design traditions would significantly speed up the time it takes to populate equations and supporting data, greatly increasing the worth of the SUBSTART database. The user interface would be considerably stressed, promoting early improvements as another benefit of having multiple users early in the development of SUBSTART. The resulting collaborative effort parallels the goals advanced by SUBSTART.

## **5.5 Closing**

SUBSTART provides a powerful framework to enhance early stage submarine design through knowledge capture. Combined with effective presentation of information, this knowledge capture enables the designer to make well informed decisions, enabling potential innovation.

There are significant impediments to implementation that must be overcome if SUBSTART is to be developed as described herein, though designers may find elements of the SUBSTART methodology beneficial if incorporated into their current processes.

## Bibliography

Burcher, Roy and Louis Rydill. *Concepts in Submarine Design*. Cambridge, Eng: Cambridge University Press, 1994.

Department of the Navy Sea Systems Command. *NSTM S9086-C6-STM-000 Chapter 096: Weights and Stability*. 1 August 1991.

Frye, Matthew and Eli Sewell "All Electric Conventional Powered Submarine Concept Design" Course 2.705 Project. Massachusetts Institute of Technology, April 2010.

Gabler, Ulrich. *Submarine Design*. Bonn: Bernard & Graefe Verlag, 2000.

Interavia Data. *Submarines of the World 88*. Ed. Armin Wetterhahn. Geneva: 1988.

Jackson, Harry A., CAPT, USN, Ret. et. al "Submarine Design Trends." Professional Summer Class Notes. Cambridge, MA: Massachusetts Institute of Technology, July 2008.

Jackson, Harry A., CAPT, USN, Ret. "Submarine Parametrics." *RINA International Symposium* London: *Royal Institution of Naval Architects*, 1983.

Jane's Fighting Ships, Ed., 2007-2008, Surrey: Jane's Information Group Ltd., 2007.

Mahonen, Chris, Will Spradley, and Matt Gerdon. "Automating Early Stage Submarine Design: Development of the Submarine Concept Design (SUBCODE) Program." *Fuel Tank to Target: Building the Electric Fighting Ship*. Arlington, VA: American Society of Naval Engineers, 2007.

Paine, Thomas O. *The Submarine Registry and Bibliography*. Santa Monica, CA: 1992.

QinetiQ GRC. "Paramarine Submarine Early Stage Design Training Course." 2009.

QinetiQ GRC. "Paramarine Submarine Introduction Training Course." 2009.

Reed, Jeffrey and Mark Welsh. "Massachusetts Institute of Technology XIII-A Submarine Math Model." July 2003.

Society of Naval Architects and Marine Engineers. *Submersible Vehicle Systems Design*. Ed. E. Eugene Allmendinger. Jersey City, NJ: 1990.

Stenard, John K. "Comparative Naval Architecture of Modern Foreign Submarines" MS Thesis. Massachusetts Institute of Technology, 1988.

Thornton, Grant B. LCDR, USN, "A Design Tool For the Evaluation of Atmosphere Independent Propulsion in Submarines." MS Thesis. Massachusetts Institute of Technology, 1994.

Torkelson, Kai Oscar. "Comparative Naval Architecture Analysis of Diesel Submarines." MS Thesis. Massachusetts Institute of Technology, 2005.

University College London. Marine Research Group. Department of Mechanical Engineering. "UCL Design Procedure for the GRC Submarine Concept Design Tool." UCLNAMEG No xxxx/06, Draft 16 May 2006.

Warren, Chris, CAPT, USN, "Once Through the Design Spiral." Professional Summer Class Notes. Cambridge, MA: Massachusetts Institute of Technology, July 2008.

## **Appendix A – SUBSTART Variable List**

| #  | Name                       | Description                               | Unit                                 |
|----|----------------------------|---|--------------------------------------|
| 1  | $r_{SW}$                   | density of seawater                       | lb-sec <sup>2</sup> /ft <sup>4</sup> |
| 2  | $f_{Curve}$                | curvature factor                          | -                                    |
| 3  | Mdol                       | cost estimate                             | \$M                                  |
| 4  | $V_{threshold}$            | speed threshold                           | Kt                                   |
| 5  | $V_{goal}$                 | speed goal                                | Kt                                   |
| 6  | $N_{crew\_officer}$        | number of officers aboard                 | people                               |
| 7  | $N_{crew\_CPO}$            | number of CPOs aboard                     | people                               |
| 8  | $N_{crew\_enlisted}$       | number of enlisted aboard                 | people                               |
| 9  | $N_T$                      | number of crew, total                     | people                               |
| 10 | E                          | endurance                                 | days                                 |
| 11 | TT                         | torpedo tubes                             | tubes                                |
| 12 | Torpedos                   | torpedos on board                         | torpedos                             |
| 13 | $D_T$                      | depth threshold                           | Ft                                   |
| 14 | $D_G$                      | depth goal                                | Ft                                   |
| 15 | $D_D$                      | depth desired                             | Ft                                   |
| 16 | Cost <sub>C</sub>          | Cost constraint                           | \$M                                  |
| 17 | $f_{Pway}$                 | passageway factor                         | -                                    |
| 18 | $f_{Frame}$                | frame factor                              | -                                    |
| 19 | $H_{Deck}$                 | height of deck                            | Ft                                   |
| 20 | Stacklength <sub>ops</sub> | stacklength in operations compartment     | Ft                                   |
| 21 | Stacklength <sub>er</sub>  | stacklength in engineroom                 | Ft                                   |
| 22 | Stacklength <sub>rc</sub>  | stacklength in reactor compartment        | Ft                                   |
| 23 | SHP                        | shaft horsepower                          | HP                                   |
| 24 | KW <sub>i</sub>            | electric plant power installed            | KW                                   |
| 25 | $r_{ER}$                   | power density of engineroom               | ft <sup>3</sup> /HP                  |
| 26 | $r_{RC}$                   | power density of reactor compartment      | ft <sup>3</sup> /HP                  |
| 27 | $V_{ER}$                   | volume of engineroom                      | ft <sup>3</sup>                      |
| 28 | $V_{RC}$                   | volume of reactor compartment             | ft <sup>3</sup>                      |
| 29 | $A_{cc}$                   | area for command and control              | ft <sup>2</sup>                      |
| 30 | $A_{bm}$                   | area for messing and berthing             | ft <sup>2</sup>                      |
| 31 | $A_{sr}$                   | area for storeroom                        | ft <sup>2</sup>                      |
| 32 | $A_{os}$                   | area for office space                     | ft <sup>2</sup>                      |
| 33 | $A_{wep}$                  | area for weapons handling                 | ft <sup>2</sup>                      |
| 34 | $A_{Dopsr}$                | area for designated operations, required  | ft <sup>2</sup>                      |
| 35 | $V_{Dopsr}$                | volume for esignated operations, required | ft <sup>3</sup>                      |
| 36 | $V_{plugr}$                | volume of plug, required                  | ft <sup>3</sup>                      |
| 37 | $V_{aux}$                  | volume of auxiliary spaces                | ft <sup>3</sup>                      |
| 38 | $V_{PH}$                   | volume of pressure hull                   | ft <sup>3</sup>                      |

|    |                  |   |                 |
|----|------------------|---|-----------------|
| 39 | $V_{VB}$         | volume of variable ballast                      | ft <sup>3</sup> |
| 40 | $V_{PH_{guess}}$ | volume of pressure hull, guess                  | ft <sup>3</sup> |
| 41 | $D_{PH}$         | displacement of pressure hull                   | LT              |
| 42 | $V_{opsr}$       | volume of operations compartment, required      | ft <sup>3</sup> |
| 43 | $A_{opsr}$       | area for operations, required                   | ft <sup>2</sup> |
| 44 | $V_{ob}$         | volume of outboard items                        | ft <sup>3</sup> |
| 45 | $r_{sa}$         | radius of sonar array                           | Ft              |
| 46 | $V_{sa}$         | volume of sonar                                 | ft <sup>3</sup> |
| 47 | $W_d$            | weight of sonar dome water                      | LT              |
| 48 | $V_d$            | volume of sonar dome                            | ft <sup>3</sup> |
| 49 | $V_{ebr}$        | volume, everbuoyant                             | ft <sup>3</sup> |
| 50 | $D_{ebr}$        | displacement, everbuoyant                       | LT              |
| 51 | RB               | reserve buoyance (fraction of $V_{ebr}$ )       | -               |
| 52 | $V_{bt}$         | volume of ballast tanks                         | ft <sup>3</sup> |
| 53 | $D_{bt}$         | displacement of ballast tanks                   | LT              |
| 54 | $V_s$            | submerged volume                                | ft <sup>3</sup> |
| 55 | $D_s$            | submerged displacement                          | LT              |
| 56 | $V_{fffrac}$     | volume of free flood as a fraction of $V_{env}$ | -               |
| 57 | $V_{envr}$       | envelope volume                                 | ft <sup>3</sup> |
| 58 | $D_{envr}$       | envelope displacement, required                 | LT              |
| 59 | $V_{ff}$         | volume of free flood                            | ft <sup>3</sup> |
| 60 | $D_{ff}$         | displacement of free flood                      | LT              |
| 61 | $h_f$            | shape factor, forward                           | -               |
| 62 | $h_a$            | shape factor, aft                               | -               |
| 63 | LOD              | length to diameter ratio                        | -               |
| 64 | D                | diameter  | Ft              |
| 65 | $L_f$            | length of forebody                              | Ft              |
| 66 | $L_a$            | length of afterbody                             | Ft              |
| 67 | $L_{pmb}$        | length of parallel midbody                      | Ft              |
| 68 | $V_{tot}$        | volume, total                                   | ft <sup>3</sup> |
| 69 | $D_{enva}$       | displacement, envelope, actual                  | LT              |
| 70 | $c_p$            | prismatic coefficient                           | -               |
| 71 | $c_{pf}$         | forward prismatic coefficient                   | -               |
| 72 | $C_{wsf}$        | wetted surface area coefficient, forward        | -               |
| 73 | $c_{pa}$         | after prismatic coefficient                     | -               |
| 74 | $c_{wsa}$        | wetted surface area coefficient, aft            | -               |
| 75 | $WS_{tot}$       | wetted surface area, total                      | ft <sup>2</sup> |
| 76 | Err <sub>V</sub> | error in volume (%): $V_{enva}$ vs. $V_{envr}$  | -               |
| 77 | $V_{eba}$        | volume, everbuoyant, available                  | ft <sup>3</sup> |
| 78 | $BT_f$           | ballast tank forward, fraction of total BT      | -               |
| 79 | $BT_{ops}$       | ballast tank ops space, fraction of total BT    | -               |

|     |                        |   |                 |
|-----|------------------------|---|-----------------|
| 80  | BT <sub>a</sub>        | ballast tank aft, fraction of total BT                                | -               |
| 81  | OB <sub>fmbt</sub>     | outboard volume, forward, fraction of total OB                        | -               |
| 82  | OB <sub>ops</sub>      | outboard volume, ops, fraction of total OB                            | -               |
| 83  | OB <sub>rc</sub>       | outboard volume, reactor compartment, fraction of total OB            | -               |
| 84  | OB <sub>er</sub>       | outboard volume, engine room, fraction of total OB                    | -               |
| 85  | OB <sub>ambt</sub>     | outboard volume, aft, fraction of total OB                            | -               |
| 86  | OB <sub>mud</sub>      | outboard volume, mud tank, fraction of total OB                       | -               |
| 87  | VL <sub>ops</sub>      | variable load, ops, fraction of VL                                    | -               |
| 88  | VL <sub>er</sub>       | Variable load, engine room, fraction of VL                            | -               |
| 89  | FF <sub>fmbt</sub>     | free flood, forward, fraction of total FF                             | -               |
| 90  | FF <sub>ops</sub>      | free flood, ops, fraction of total FF                                 | -               |
| 91  | FF <sub>rc</sub>       | free flood, reactor compartment, fraction of total FF                 | -               |
| 92  | FF <sub>er</sub>       | free flood, engine room, fraction of total FF                         | -               |
| 93  | FF <sub>ambt</sub>     | free flood, aft, fraction of total FF                                 | -               |
| 94  | FF <sub>mud</sub>      | free flood, mud tank, fraction of total FF                            | -               |
| 95  | Dome <sub>lfrac</sub>  | longitudinal location of sonar dome bulkhead, fraction of L           | -               |
| 96  | FMBT <sub>lfrac</sub>  | longitudinal location of FMBT bulkhead, fraction of L                 | -               |
| 97  | Dome <sub>aft</sub>    | longitudinal location of aft sonar dome bulkhead                      | Ft              |
| 98  | FMBT <sub>l_aft</sub>  | longitudinal location of aft bulkhead of FMBT bulkhead                | Ft              |
| 99  | FMBT <sub>aft</sub>    | longitudinal location of aft bulkhead of FMBT bulkhead, fraction of L | Ft              |
| 100 | MUD <sub>lfrac</sub>   | longitudinal location of mud tank bulkhead, fraction of L             | -               |
| 101 | ERAFT <sub>frac</sub>  | longitudinal location of AMBT fwd bulkhead (aft ER), fraction of L    | -               |
| 102 | ERFWD <sub>frac</sub>  | longitudinal location of FWD ER (aft RC) bulkhead, fraction of L      | -               |
| 103 | RCFWD <sub>frac</sub>  | longitudinal location of FWD RC bulkhead, fraction of L               | -               |
| 104 | MUD <sub>fwd</sub>     | longitudinal location of forward bulkhead of mud tank                 | Ft              |
| 105 | ER <sub>aft</sub>      | Longitudinal location of forward bulkhead of AMBT (aft ER)            | Ft              |
| 106 | ER <sub>l_fwd</sub>    | longitudinal location of forward bulkhead of ER                       | Ft              |
| 107 | V <sub>extra</sub>     | Volume margin   | ft <sup>3</sup> |
| 108 | ER <sub>fwd</sub>      | longitudinal location of forward ER bulkheadh                         | Ft              |
| 109 | OPSFWD <sub>frac</sub> | longitudinal location of FWD OPS bulkhead, fraction of L              | -               |
| 110 | OPS <sub>fwd</sub>     | longitudinal location of FWD OPS bulkhead                             | Ft              |
| 111 | Decks                  | number of decks   | Ft              |
| 112 | Deck_Height            | deck heights, array   | Ft              |
| 113 | L <sub>plug</sub>      | length of plug  | Ft              |
| 114 | Err <sub>OPSarr</sub>  | Error in arrangeable area   | -               |
| 115 | W <sub>1frac</sub>     | weight of Group 1, as a fraction of NSC                               | -               |
| 116 | K3                     | Group 3 K3  | LT/kW           |
| 117 | W <sub>4frac</sub>     | weight of Group 4, as a fraction of NSC                               | -               |
| 118 | W <sub>5frac</sub>     | weight of Group 5, as a fraction of NSC                               | -               |
| 119 | W <sub>6frac</sub>     | weight of Group 6, as a fraction of NSC                               | -               |
| 120 | W <sub>7est</sub>      | weight of Group 7 estimate  | LT              |
| 121 | W <sub>PPfrac</sub>    | weight of lead, as a fraction of A-1                                  | -               |
| 122 | W <sub>VLfrac</sub>    | weight of Variable load, as a fraction of NSC                         | -               |
| 123 | A <sub>lfrac</sub>     | weight of A-1, as a fraction of NSC                                   | -               |
| 124 | D <sub>surfest</sub>   | displacement, surface condition, estimate                             | LT              |

|     |                     |   |                 |
|-----|---------------------|---|-----------------|
| 125 | $D_{eba}$           | displacement, everbuoyant, available                                    | LT              |
| 126 | Err                 | error - $D_{eba}$ compared with $D_{surf}$                              | %               |
| 127 | $A_{opsa}$          | area of operations spaces, available                                    | ft <sup>2</sup> |
| 128 | $D_{surf}$          | Surfaced displacement   | LT              |
| 129 | L                   | length  | Ft              |
| 130 | $NSC_{est}$         | weight in Normal Surface Condition, based on parametrics                | LT              |
| 131 | $RC_{fwd}$          | location of fwd RC bulkhead   | Ft              |
| 132 | $W_{PB}$            | weight of lead  | LT              |
| 133 | $W_{VL}$            | weight of variable ballast  | LT              |
| 134 | W                   | weight  | LT              |
| 135 | LCG                 | longitudinal Center of Gravity  | Ft              |
| 136 | VCG                 | height of Vertical Center of Gravity                                    | Ft              |
| 137 | $LCG_{A1}$          | distance, longitudinal center of gravity from FP, A-1                   | Ft              |
| 138 | $VCG_{A1}$          | height of vertical center of gravity, A-1                               | Ft              |
| 139 | $LCB_{De}$          | longitudinal center of gravity, envelope displacement                   | Ft              |
| 140 | $LCB_{Ds}$          | distance of longitudinal center of gravity from FP, submerged condition | Ft              |
| 141 | $VCB_{MBT}$         | height of vertical center of gravity, main ballast tanks                | Ft              |
| 142 | $V_{fmbt}$          | volume, forward main ballast tank                                       | ft <sup>3</sup> |
| 143 | $V_{ambt}$          | volume, aft main ballast tank   | ft <sup>3</sup> |
| 144 | $V_{midmbt}$        | volume, mid main ballast tank   | ft <sup>3</sup> |
| 145 | $LCB_{mbt}$         | distance of longitudinal center of gravity from FP, main ballast tank   | Ft              |
| 146 | $D_{mbt}$           | displacement, main ballast tank   | LT              |
| 147 | $D_A$               | displacement, A-condition   | LT              |
| 148 | $W_i$               | weight of i <sup>th</sup> group, for calculating LCG and VCG            | LT              |
| 149 | $LCG_i$             | longitudinal center of gravity of ith weight group                      | Ft              |
| 150 | $VCG_i$             | height of vertical center of gravity of i <sup>th</sup> weight group    | Ft              |
| 151 | $LCB_{ff}$          | distance of longitudinal center of buoyancy from FP, free flood volumes | Ft              |
| 152 | $LCG_{LEAD}$        | longitudinal center of gravity of lead                                  | Ft              |
| 153 | $VCG_A$             | vertical center of gravity, A-condition                                 | Ft              |
| 154 | $V_{VLI}$           | Volume of variable load items   | ft <sup>3</sup> |
| 155 | $LCG_{nsc}$         | longitudinal center of gravity, normal surface condition                | Ft              |
| 156 | $VCG_{nsc}$         | vertical center of gravity, normal surface condition                    | ft <sup>3</sup> |
| 157 | $V_{VBact}$         | volume of variable ballast, actual                                      | ft <sup>3</sup> |
| 158 | $VCG_{LEADs}$       | vertical center of gravity of lead                                      | Ft              |
| 159 | $D_{nsc}$           | displacement, normal surface condition                                  | LT              |
| 160 | $LCG_{VL}$          | longitudinal center of gravity of variable loads                        | Ft              |
| 161 | $VCG_{VL}$          | vertical center of gravity of variable loads                            | Ft              |
| 162 | $LCG_A$             | longitudinal center of gravity, A-condition                             | Ft              |
| 163 | Error <sub>VB</sub> | error in variable ballast   | %               |
| 164 | $W_{pbfr}$          | weight of lead, forward, required                                       | LT              |
| 165 | $W_{vlfr}$          | weight of variable load, forward, required                              | LT              |
| 166 | $VCG_{LEADs}$       | vertical center of gravity, stability lead                              | Ft              |
| 167 | $VCG_{LEADm}$       | vertical center of gravity, margin lead                                 | Ft              |
| 168 | $W_{pbs}$           | weight of stability lead  | LT              |

|     |                 |   |                      |
|-----|-----------------|---|----------------------|
| 169 | $W_{pbm}$       | weight of margin lead   | LT                   |
| 170 | $LCG_{LEADs}$   | longitudinal center of gravity, stability lead                          | Ft                   |
| 171 | $LCG_{LEADm}$   | longitudinal center of gravity, margin lead                             | Ft                   |
| 172 | $LCG_{pbm}$     | longitudinal center of buoyancy, margin lead                            | Ft                   |
| 173 | $x$             | longitudinal distance from FP   | Ft                   |
| 174 | $R(x)$          | radius at longitudinal distance from FP, $x$                            | Ft                   |
| 175 | $c_{ws}$        | wetted surface coefficient  | -                    |
| 176 | $t$             | draft, measured from baseline   | Ft                   |
| 177 | $q(x,t)$        | angle formed by the triangle from section center to waterline at $x$    | degrees              |
| 178 | $A(x,t)$        | area of section below waterline at $x$                                  | ft <sup>2</sup>      |
| 179 | $kb(x,t)$       | centroid of the portion of sectional area that is below the waterline   | Ft                   |
| 180 | $wl(x,t)$       | length (or breadth) of waterline at $x$                                 | Ft                   |
| 181 | $wsa(x,t)$      | wetted surface (or arc length) of section below the waterline           | ft <sup>2</sup>      |
| 182 | $WS(t)$         | wetted surface of the envelope at draft $t$                             | ft <sup>2</sup>      |
| 183 | $A_{wp}(t)$     | waterplane area at draft $t$  | ft <sup>2</sup>      |
| 184 | $LCF(t)$        | longitudinal center of flotation (centroid of waterplane) at draft $t$  | Ft                   |
| 185 | $V(t)$          | volume of the submerged envelope for draft $t$                          | ft <sup>3</sup>      |
| 186 | $D(t)$          | displacement of the submerged envelope at draft $t$                     | LT                   |
| 187 | $VCB(t)$        | vertical center of buoyancy (centroid of volume) at draft $t$           | Ft                   |
| 188 | $LCB(t)$        | longitudinal center of buoyancy (centroid of volume) at draft $t$       | Ft                   |
| 189 | $I_t(t)$        | transverse moment of inertia of the waterplane at draft $t$             | ft <sup>4</sup>      |
| 190 | $BM_t(t)$       | transverse metacentric radius at draft $t$                              | Ft                   |
| 191 | $I_l(t)$        | longitudinal moment of inertia of the waterplane at draft $t$           | ft <sup>4</sup>      |
| 192 | $BM_l(t)$       | longitudinal metacentric radius at draft $t$                            | Ft                   |
| 193 | $TPI(t)$        | tons per inch immersion at draft $t$                                    | LT/in                |
| 194 | $MT1(t)$        | moment to trim one inch at draft $t$                                    | ft-LT/in             |
| 195 | $FF_{surf}$     | Assumed free flood at surface condition, as a percent of submerged      | %                    |
| 196 | $VCB_{ff}$      | vertical center of buoyancy of the free flood volume, surface condition | Ft                   |
| 197 | $D_{envsurf}$   | envelope displacement on the surface                                    | LT                   |
| 198 | $KG_{envsurf}$  | height of center of gravity of envelope volume, surface condition       | Ft                   |
| 199 | $LCG_{envsurf}$ | longitudinal center of gravity of envelope, surface condition           | Ft                   |
| 200 | $t_{envsurf}$   | envelope surfaced draft   | Ft                   |
| 201 | $FS_{corr}$     | free surface correction (virtual rise in G)                             | Ft                   |
| 202 | $KM_{envsurf}$  | height of metacenter above keel, envelope at surface                    | Ft                   |
| 203 | $KM_{nsc}$      | height of metacenter above keel, normal surface condition               | Ft                   |
| 204 | $GM_t$          | metacentric height at draft $t$   | ft                   |
| 205 | trim            | difference in drafts at FP and AP, - means by the stern                 | ft                   |
| 206 | $T_{SW}$        | temperature of seawater   | °F                   |
| 207 | $\nu_{sw}$      | kinematic viscosity of seawater   | ft <sup>2</sup> /sec |
| 208 | $WS(D)$         | area wetted surface, as a function of diameter                          | ft <sup>2</sup>      |
| 209 | $C_a$           | correlation allowance (a coefficient of resistance or drag)             | -                    |
| 210 | $C_f(V)$        | coefficient of friction resistance                                      | -                    |
| 211 | $C_{ff}$        | coefficient of friction and form resistance                             | -                    |
| 212 | $A_s$           | area of wetted surface of the sail                                      | ft <sup>2</sup>      |
| 213 | $C_{Ds}$        | coefficient of drag, sail   | -                    |

|     |                      |   |                 |
|-----|----------------------|---|-----------------|
| 214 | $A_{app}C_{dapp}$    | area of wetted surface times coefficient of drag, appendages                        | ft <sup>2</sup> |
| 215 | $EHP_{submerged}(V)$ | effective power, as a function of speed, submerged                                  | HP              |
| 216 | $h_o$                | open water propeller efficiency, as a fraction of 1.0                               | -               |
| 217 | $D_p$                | diameter of propeller   | ft              |
| 218 | $C_{ws}$             | coefficient of wetted surface   | -               |
| 219 | $w_1$                | wake fraction   | -               |
| 220 | $t_1$                | thrust deduction  | -               |
| 221 | $h_h$                | hull efficiency, as a fraction of 1.0   | -               |
| 222 | $h_{rr}$             | relative rotative efficiency of propeller, as a fraction of 1.0                     | -               |
| 223 | PC                   | propulsive coefficient, as a fraction of 1.0  | -               |
| 224 | $SHP_{submerged}(V)$ | shaft horsepower of submarine, as a function of speed, submerged                    | HP              |
| 225 | Froude               | Froude number, array of values over surface condition operating range               | -               |
| 226 | CT                   | coefficient of total resistance, as a function of Froude (number)                   | -               |
| 227 | CT(x)                | coefficient of total resistance, used to calculate actual SHP in surfaced condition | -               |
| 228 | Froud(v)             | Froude number, used to calculate actual SHP in surfaced condition                   | -               |
| 229 | $SHP_{surfaced}(V)$  | shaft horsepower of submarine, as a function of speed, surfaced                     | HP              |
| 230 | q                    | speed limit based on installed power, surface condition                             | kts             |
| 231 | PMF                  | power margin factor, as a fraction of 1.0   | -               |
| 232 | $V_{max\_surfaced}$  | maximum speed, at surface   | kts             |
| 233 | $V_{max\_submerged}$ | maximum speed, submerged  | kts             |
| 234 | $CER_{W1}$           | Cost estimating ratio for weight group W1   | \$/LT           |
| 235 | $CER_{W2}$           | Cost estimating ratio for weight group W2   | \$/LT           |
| 236 | $CER_{W3}$           | Cost estimating ratio for weight group W3   | \$/LT           |
| 237 | $CER_{W4}$           | Cost estimating ratio for weight group W4   | \$/LT           |
| 238 | $CER_{W5}$           | Cost estimating ratio for weight group W5   | \$/LT           |
| 239 | $CER_{W6}$           | Cost estimating ratio for weight group W6   | \$/LT           |
| 240 | $CER_{W7}$           | Cost estimating ratio for weight group W7   | \$/LT           |
| 241 | $V_{PH-VB}$          | Volume, pressure hull sans trim and compensating system                             | ft <sup>3</sup> |
| 242 | $f_{Outboard}$       | Outboard item volume, as a fraction of $V_{PH}$                                     | -               |
| 243 | $f_{Utility}$        | Utility fraction of tanks, accounts for internal structure and ullage               | -               |
| 244 | pvf                  | Fraction of $V_{Env}$ devoted to payload  | -               |
| 245 | pwf                  | Fraction of $W_{A-1}$ devoted to payload  | -               |
| 246 | $V_{Payload}$        | Volume, payload   | ft <sup>3</sup> |
| 247 | $N_{comp\_officer}$  | number of officers in crew complement   | people          |
| 248 | $N_{comp\_CPO}$      | number of CPOs in crew complement   | people          |
| 249 | $N_{comp\_enlisted}$ | number of enlisted in crew complement   | people          |
| 250 | $N_{comp\_T}$        | number of people in crew complement, total  | people          |

## Appendix B – SUBSTART Data Structure View

The SUBSTART data structure view has been modified for viewing so that the formulas are expanded and can be seen. Named variables in the equations link to the promoted value box for the respective value. The unit variables and  $\rho_{SW}$  are constants that conditionally modify from metric to U.S. values based on a selection made elsewhere in the program.

The promoted value box calculations contain a simple nested IF-THEN form. There is as many IF statements as there are choices in the dropdown box.

The syntax is: IF(logical\_test,value\_if\_true,value\_if\_false)

The promoted value formulas are all of the form: =IF(Dropdown\_Box=1,Solution1, IF(Dropdown\_Box =2, Solution2, IF(Dropdown\_Box =3, Solution3,"N/A")))

**V<sub>PH-VB</sub>**

|   |   | =IF(C5=1,E6,IF(C                  | =Units_Volume |
|---|---|-----------------------------------|---------------|
| 1 | 2 | V <sub>Payload</sub> /0.3         |               |
|   |   | =V_Payload/0.3                    |               |
|   | 2 | V <sub>PH</sub> - V <sub>VB</sub> |               |
|   |   | =V <sub>PH</sub> -V <sub>VB</sub> |               |
|   | 3 | Override                          |               |

Notes: This volume considers the volume internal to the pressure hull, with the exception of the volume used by the Trim/Compensation System. <1> [Burcher] Ch11.19

**V<sub>Payload</sub>**

|   |   | =IF(C18=1,E19,IF                         | =Units_Volume |
|---|---|--|---------------|
| 6 | 2 | pvf * V <sub>Envelope</sub>              |               |
|   |   | =pvf*V_Envelope                          |               |
|   | 2 | pvf * V <sub>PH</sub>                    |               |
|   |   | =pvf*V_PH                                |               |
|   | 3 | W <sub>Payload</sub> / $\rho_{SW}$       |               |
|   |   | =W_Payload/Density_Seawater              |               |
|   | 4 | $\Sigma$ Payload Space&Component Volumes |               |
|   |   |  |               |
|   | 5 | 0.3 * V <sub>PH-VB</sub>                 |               |
|   |   | =0.3*V_PH_minus_VB                       |               |
|   | 6 | Override                                 |               |

Notes: <4> refers to the sum of all payload spaces as tabulated in the tab Area/Volume.

**pvf**

|   |   |                                | %        |
|---|---|--------------------------------|----------|
| 4 | 2 | SSK = 28%                      |          |
|   |   | 0.28                           |          |
|   | 2 | SSN = 30%                      |          |
|   |   | 0.3                            |          |
|   | 3 | 0.2                            |          |
|   |   | 0.2                            |          |
|   | 4 | 6% < pvf < 32%                 | "----->" |
|   |   | 0.175                          |          |
|   | 5 | $V_{Payload} / V_{Envelope}$   |          |
|   |   | = $V_{Payload} / V_{Envelope}$ |          |
|   | 6 | $V_{Payload} / V_{PH}$         |          |
|   |   | = $V_{Payload} / V_{PH}$       |          |
|   | 7 | Override                       |          |

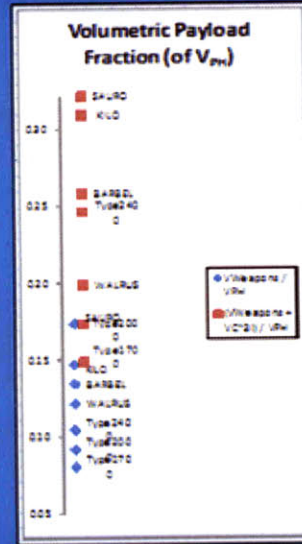
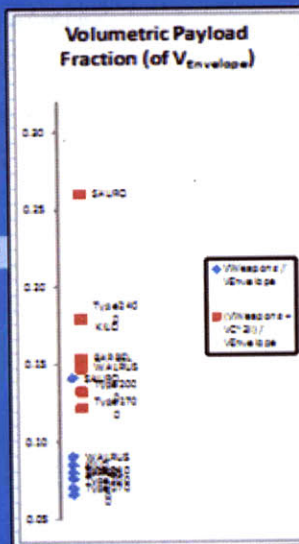

Notes: Payload Volume Fraction of Everbuoyant Volume or Pressure Hull Volume (check usage context for which is appropriate) <1> and <2> refer to [Burcher] Table 4.1 and 4.2 respectively ( $V_{PH}$ ). <3> refers to [UCL] Ch2.3 <4> refers to [Reed] with additional data in tab SUBVOL\_WTS Reed (with regards to either  $V_{Envelope}$  or  $V_{PH}$ ).

**pwf**

|   |   |   | %        |
|---|---|---|----------|
| 3 | 1 | SSK = 9%  |          |
|   |   | 0.09  |          |
|   | 2 | SSN = 8%  |          |
|   |   | 0.08  |          |
|   | 3 | 2% < pwf < 11%                                      | "----->" |
|   |   | 0.102   |          |
|   | 4 | 0.05  |          |
|   |   | 0.05  |          |
|   | 5 | $W_7 / W_{A-1}$                                     |          |
|   |   |   |          |
|   | 6 | $(W_4 + W_7) / W_{A-1}$                             |          |
|   |   |   |          |
|   | 7 | $\Sigma$ Payload Space&Component Weights/ $W_{A-1}$ |          |
|   |   |   |          |
|   | 8 | Override  |          |

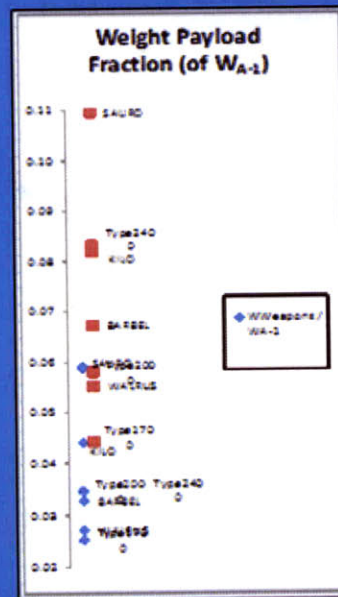

Notes: Payload Weight Fraction of A-1 weight. <1> and <2> refer to [Burcher] Table 4.1 and 4.2 respectively. <3> refers to [Reed] with additional data in tab SUBVOL\_WTS Reed. <4> refers to [UCL] Ch2.3. <5> calculates the SWBS weight group 7 percentage of A-1 weight. <6> include SWBS weight group 4 to the results of <5>. <7> calculates from the weights tabulated in the tab Area/Volume.

### $W_{\text{Payload}}$

|   |   |  | =Units_Weight |
|---|---|--|---------------|
| 5 | 1 | $\text{pwf} * W_{A-1}$   |               |
|   | 2 | $W_7$  |               |
|   | 3 | $W_4 + W_7$  |               |
|   | 4 | $V_{\text{Payload}} * \rho_{\text{sw}}$<br>=V_Payload*Density_Seawater |               |
|   | 5 | Override   |               |

Notes: <4> refers to the sum of all payload spaces as tabulated in the tab Area/Volume.

### $V_{\text{VB}}$

|   |   |  | =Units_Volume |
|---|---|--|---------------|
| 1 | 1 | $[V_{\text{PH-VB}} * (\rho_{\text{max}} - \rho_{\text{min}}) / \rho_{\text{sw}} + W_{\text{Stores}} / \rho_{\text{sw}}] / F_{\text{Utility}}$<br>=(V_PH_minus_VB*(Density_Seawater_Max-Density_Seawater_Min)/Density_Seawater+W_Stores/Density_Seawater) |               |
|   | 2 | $0.045 * V_{\text{Surface Displacement}} / F_{\text{Utility}}$<br>=0.045*V_Submerged_Displacement/F_Utility  |               |
|   | 3 | $0.064 * V_{\text{PH}}$<br>=0.064*V_PH   |               |
|   | 4 | Override   |               |

Notes: <1> and <2> refer to [Burcher] Ch11.20. <3> refers to a regression equation from [SMM].

### $\rho_{\text{max}}$

|   |   |   | =Units_Density |
|---|---|---|----------------|
| 1 | 1 | 64.3 lbs/ft <sup>3</sup><br>=(64.3/64)*Density_Seawater |                |
|   | 2 | Override  |                |

Notes: <1> refers to [NSTM Ch096]

### $P_{min}$

|   |   | =Units_Density  |
|---|---|---|
| 1 | 2 | 63.6 lbs/ft <sup>3</sup><br>=(63.6/64)*Density_Seawater |
|   | 2 | 63.0 lbs/ft <sup>3</sup><br>=(63/64)*Density_Seawater   |
|   | 3 | Override  |

Notes: <1> and <2> refers to [NSTM Ch096]. <2> represents an Arctic condition.

### $F_{Utility}$

|   |   | =Units_Weight | %    |
|---|---|---------------|------|
| 1 | 1 | 95 %          | 0.95 |
|   | 2 | 91 %          | 0.91 |
|   | 3 | < 98%         |      |
|   | 4 | Override      |      |

Notes: The utility factor reduces the amount of volume due to internal structure and ullage. <1> refers to a nominal value used in [Burcher] Ch11.20. <2> refers to a nominal value used in [Burcher] Appendix 3. <3> is the limits required by [ABS].

### $W_{Stores}$

|   |   | =Units_Weight                           |
|---|---|---|
| 3 | 1 | $K_{Stores} * N_{Crew} * EnduranceDays$ |
|   | 2 | $V_{Stores} * P_{Stores}$               |
|   | 3 | Override                                |

Notes: <1> [Burcher] Ch11.x <2> applies a packing factor to the available stores volume

### $V_{PH}$

|   |   | <code>=IF(C171=1,E172)</code>  | <code>=Units_Volume</code> |
|---|---|--|----------------------------|
| 1 | 2 | $V_{PH+VB} + V_{VB}$<br><code>=V_PH_minus_VB+V_VB</code>                                   |                            |
|   | 2 | $V_{OPS} + V_{FP} + V_{Auk} + V_{VB}$  |                            |
|   | 3 | $V_{Everbouyant} / (1 + F_{Outboard})$<br><code>=V_Everbouyant/(1+F_Outboard_Items)</code> |                            |
|   | 4 | $V_{VB} / 0.064$<br><code>=V_VB/0.064</code>   |                            |
|   | 5 | $V_{Pylons} / pvf$<br><code>=V_VB/0.064</code>   |                            |
|   | 6 | $L_{PH} * \pi * (D_{PH}^2) / 4$  |                            |
|   | 7 | Override   |                            |

Notes: <1> [Burcher] Ch11.21. <2> Derived from [SMM]. <5> assumes pvf is given in relation to  $V_{PH}$  (as opposed to  $V_{Everbouyant}$ )  
<6> Cylindrical estimate disregarding shape of endcaps.

### $V_{Everbouyant}$

|   |   | <code>=IF(C192=1,E193)</code>   | <code>=Units_Volume</code> |
|---|---|---|----------------------------|
| 1 | 2 | $V_{PH} * (1 + F_{Outboard_Items})$<br><code>=V_PH*(1+F_Outboard_Items)</code>                  |                            |
|   | 2 | $\Delta_{REC} * \rho_{sw}$  |                            |
|   | 3 | $V_{PH} + V_{Outboard} + V_{Somer} + V_{SomerWater}$  |                            |
|   | 4 | $V_{SubmergedDisplacement} - V_{MBT}$<br><code>=V_Submerged_Displacement-V_MBT</code>           |                            |
|   | 5 | $(V_{MBT} * F_{Utility}) / ReserveBuoyancy$<br><code>=(V_MBT*F_Utility)/Reserve_Buoyancy</code> |                            |
|   | 6 | Override  |                            |

Notes: <1> [Burcher] Ch11.1. <2> Displacement resulting from normal surface condition weight. <3> [SMM] sums component volumes.

### F<sub>OutboardItems</sub>

|   |   | =IF(C211=1,E212)                                 | % |
|---|---|--|---|
| 1 | 1 | 0.15   |   |
|   |   | 0.15   |   |
| 2 |   | 0.222  |   |
|   |   | 0.222  |   |
| 3 |   | $(V_{\text{Everbouyant}} / V_{\text{PH}}) - 1$   |   |
|   |   | $= (V_{\text{Everbouyant}} / V_{\text{PH}}) - 1$ |   |
| 4 |   | Override   |   |

Notes: The outboard item factor refers to the volume of bouyant bodies outside the pressure hull, as a percentage of the pressure hull volume. <1> refers to a nominal value used in [Burcher] Ch11.x. <2> refers to a nominal value used in [SMM]

### V<sub>MBT</sub>

|   |   | =IF(C227=1,E228)   | =Units_Volume |
|---|---|--|---------------|
| 1 | 1 | $V_{\text{Everbouyant}} * \text{ReserveBouyancy} / F_{\text{Utility}}$     |               |
|   |   | $= V_{\text{Everbouyant}} * \text{Reserve\_Bouyancy} / F_{\text{Utility}}$ |               |
| 2 |   | $V_{\text{Submerged Displacement}} - V_{\text{Everbouyant}}$               |               |
|   |   | $= V_{\text{Submerged\_Displacement}} - V_{\text{Everbouyant}}$            |               |
| 3 |   | $\Delta_{\text{MBT}} / \rho_{\text{sw}}$                                   |               |
| 4 |   | Override / From Geometry   |               |

Notes: <1> As calculated in [Burcher] Ch11.21. [SMM] uses the same calculation with a F<sub>utilty</sub> of 1.

### V<sub>SubmergedDisplacement</sub>

|   |   | =IF(C242=1,E243)                                     | =Units_Volume |
|---|---|--|---------------|
| 1 | 2 | $V_{\text{Everbouyant}} + V_{\text{MBT}}$            |               |
|   |   | $= V_{\text{Everbouyant}} + V_{\text{MBT}}$          |               |
| 2 |   | $\Delta_{\text{submerged}} / \rho_{\text{sw}}$       |               |
| 3 |   | $V_{\text{Envelope}} / (1 + F_{\text{FreeFlood}})$   |               |
|   |   | $= V_{\text{Envelope}} / (1 + F_{\text{FreeFlood}})$ |               |
| 4 |   | $V_{\text{Envelope}} * (1 - F_{\text{FreeFlood}})$   |               |
|   |   | $= V_{\text{Envelope}} * (1 - F_{\text{FreeFlood}})$ |               |
| 5 |   | Override   |               |

Notes: <1> [Burcher] Ch11.21. <2> [SMM] <3> assumes F<sub>FreeFlood</sub> is a percentage of V<sub>SubmergedDisplacement</sub>. <4> assumes F<sub>FreeFlood</sub> is a percentage of V<sub>Envelope</sub>.

### V<sub>Envelope</sub>

|                 |   |  |
|-----------------|---|--|
| =IF(C259=1,E260 |   | =Units_Volume  |
| 1               | 2 | V <sub>Submerged Displacement</sub> * (1 + F <sub>FreeFlood</sub> )<br>=V_Submerged_Displacement*(1+F_FreeFlood) |
|                 | 2 | V <sub>Submerged Displacement</sub> / (1 - F <sub>FreeFlood</sub> )<br>=V_Submerged_Displacement/(1-F_FreeFlood) |
|                 | 3 | (Power <sub>in</sub> / K <sub>p</sub> * U <sub>hull</sub> <sup>2.9, 1/0.64</sup> )                               |
|                 | 4 | V <sub>Payload</sub> / pvf<br>=V_Payload/pvf   |
|                 | 5 | Override   |

Notes: <1> [Burcher] Ch11.21 assumes the free flood fraction is a percentage of V<sub>Submerged Displacement</sub>. <1> [SMM] assumes the free flood fraction is a percentage of V<sub>Envelope</sub>. <3> [Burcher] Ch11.22 assumes metric units and a "typical" hull form. <4> assume pvf is given in relation to V<sub>Envelope</sub> (as opposed to V<sub>sub</sub>).

### F<sub>FreeFlood</sub>

|                 |   |  |
|-----------------|---|--|
| =IF(C277=1,E278 |   | %  |
| 1               | 1 | 15 %<br>0.15   |
|                 | 2 | (V <sub>Envelope</sub> / V <sub>Submerged Displacement</sub> ) - 1<br>=(V_Envelope/V_Submerged_Displacement) |
|                 | 3 | V <sub>Free Flood</sub> / V <sub>Envelope</sub>  |
|                 | 4 | V <sub>Free Flood</sub> / V <sub>Submerged Displacement</sub>  |
|                 | 5 | Override   |

Notes: The freeflood fraction refers to the volume of freeflood as a percentage of either V<sub>Envelope</sub> or V<sub>Submerged Displacement</sub>. See the calculation of V<sub>Envelope</sub> or V<sub>Submerged Displacement</sub> for intended use. <1> refers to a nominal value used in [Burcher] Ch11.21. <2> refers to a nominal value used in [SMM].

### Reserve Bouyancy

|   |   | =IF(C295=1,E296                             | % |
|---|---|---|---|
| 1 | 1 | 15 %  |   |
|   |   | 0.15  |   |
| 2 | 2 | 12.5%                                       |   |
|   |   | 0.125                                       |   |
| 3 | 3 | $(V_{MBT} * F_{Utility}) / V_{Everbouyant}$ |   |
|   |   | $=(V_{MBT}*F_{Utility})/V_{Everbouyant}$    |   |
| 4 | 4 | Override                                    |   |

Notes: <1> refers to a nominal value used in [Burcher] CH11.x. <2> refers to a standard value used in [SMM].