

Towards Neighborhood Responsive Design Guidelines

by

Rolf Leonard Oliver

B. Arts, Carleton College, 1962

B. Arch., University of Minnesota, 1976

SUBMITTED IN PARTIAL FULFILLMENT
OF THE REQUIREMENTS OF THE
DEGREES OF

MASTER OF ARCHITECTURE IN ADVANCED STUDIES

and

MASTER OF CITY PLANNING

at the

MASSACHUSETTS INSTITUTE OF TECHNOLOGY

February, 1980

© Rolf Leonard Oliver 1980

The author hereby grants to M.I.T. permission to reproduce and to distribute copies of this thesis document in whole or in part.

Signature of Author _____

Department of Urban Studies and Planning
January 18, 1980

Certified by _____

Thomas E. Nutt-Powell, Thesis Supervisor

Accepted by _____

ROTH Professor Langley E. Keyes
MASSACHUSETTS INSTITUTE OF TECHNOLOGY Departmental Graduate Committee

NOV 21 1980

LIBRARIES

Towards Neighborhood Responsive Design Guidelines

by

ROLF L. OLIVER

Submitted to the Department of Urban Studies and Planning and Architecture on January 18, 1980, in partial fulfillment of the requirements for the Degrees of Master of Architecture in Advanced Studies and Master of City Planning.

ABSTRACT

This thesis is based on the premise that desirable district qualities can be enhanced and protected from new physical development by design guidelines that make design issues understandable to laypeople and professionals alike. By such a vehicle, preconceived physical models, often advocated by professionals, can be moderated by laypeople, whose environment will be adversely affected by professionally inspired interventions.

Part I examines the urban form models in common use. Of these models, the Block City model best describes existing urban context. A descriptive method is developed for examining this model and the interventions that often occur within it.

Part II shows how a neighborhood-responsive design guideline structure can be constructed within Block City model districts.

Part III examines an urban setting and an inner-city neighborhood threatened by new physical development. It demonstrates how, in several development scenarios, the guideline structure can be utilized.

Part IV provides a brief summary of the study and evaluates various aspects of the design guidelines as a mechanism for controlling physical development.

Thesis Supervisor: Thomas E. Nutt-Powell

Table of Contents

	Page
Abstract	2
Table of Contents	3
Acknowledgements	4
Part I	
Chapter One Introduction	6
Chapter Two Understanding District	40
Chapter Three District Intervention	109
Part II	
Chapter Four Developing Design Guidelines	164
Part III	
Chapter Five Minneapolis and Elliot Park	192
Chapter Six Scenario One: Augustana Nursing Home	239
Chapter Seven Scenario Two: Ninth Street Greenway	266
Chapter Eight Scenario Three: Elliot Park East	294
Part IV	
Chapter Nine Conclusion	321
Footnotes	328
Bibliography	329
Illustration Credits	335

ACKNOWLEDGEMENTS

To Victor and Alma for the past

To Marsha for the present

To Karl and Leslie for the future

To John for the opportunity

To Tunney for the access

To Tom for the guidance

To Phil for the perspective

To M.I.T. students for the companionship

To LBI Company for the loan

Part I

Part I is an introduction to the study. It reviews the built form models found in urban neighborhoods from a standpoint of context and new intervention by professionals. After it reviews these models, it examines two neighborhoods with satisfactory district environments where the built environment has a generally agreed upon quality. This examination provides the basis for creating design guidelines. The last portion briefly surveys typical interventions in neighborhood contexts, illustrating how and under what circumstances they violate neighborhood physical structure.

Chapter One

Introduction

Our nation and the world are in a time of uncertainty, since the assumed benefits of industrialization are being questioned by concerned citizens who ponder the impact of industrial development on the environment, the extravagant use of earth resources, and the inability to alleviate social injustice.

In architecture and planning, similar questions concerning industrial society are being asked. The urban theories advanced by the Modern Movement are now met with skepticism after decades of urban demolition and rebuilding. Many of the assumptions of the Modern Movement are being challenged for thoughtful professionals. Among these assumptions is the primacy of the privately developed buildings over their built context. This contextual insensitivity has pervaded the Modern Movement, which ironically has always found inspiration in vernacular Mediterranean environments (see Figures 1-1 and 1-2), often considered the ultimate models for contextual continuity.

An emergent force in architecture and planning is local citizen participation in physical development, which no longer leaves the professional with an unrestrained hand in urban development. One result is that architecture and planning professionals are reassessing theories of city formation after recent efforts to impose professionally inspired models have failed as interventions in existing contexts. This thesis is a part of that professional reexamination. It will look at new methods for understanding urban structure as well as new mechanisms for citizen involvement in physical planning. The focus



Figure 1-1

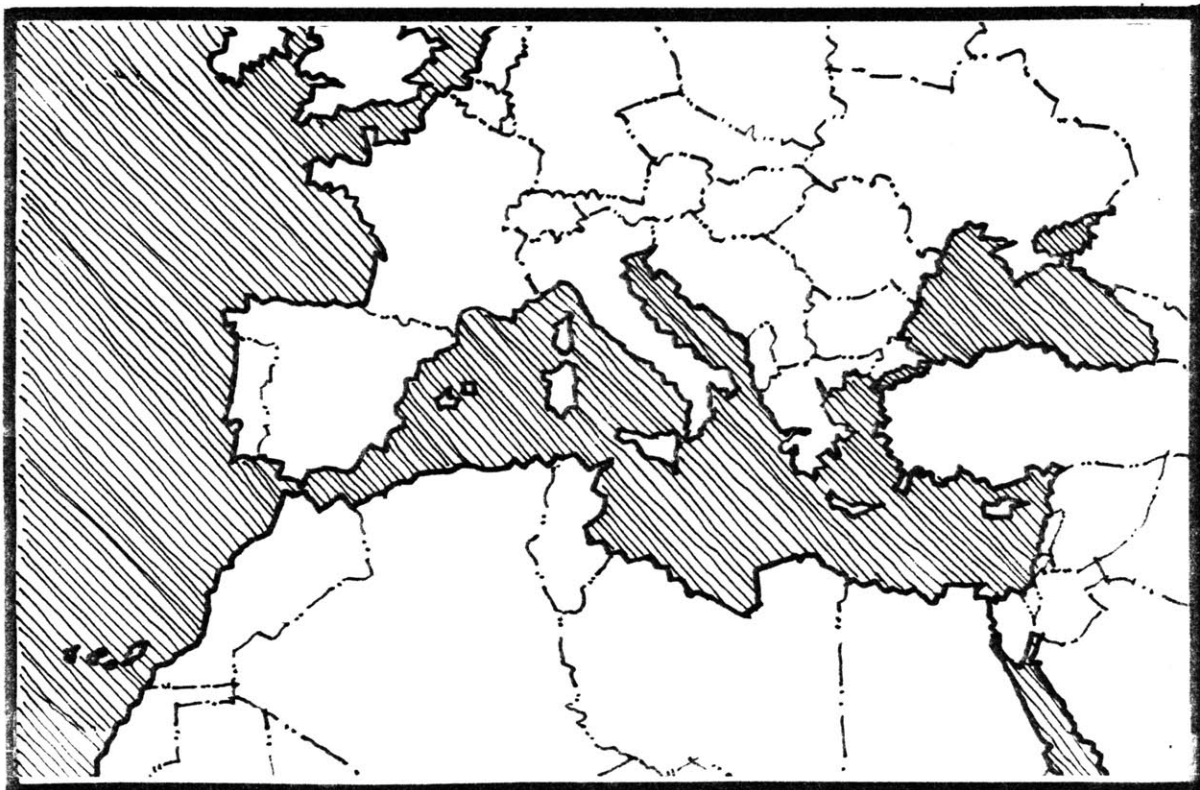

Figure 1-2

of the thesis is on physical planning within existing urban neighborhoods experiencing development pressure.

For purposes of this study, we will view the physical city abstractly as a dialectic between built space (solid volumes) and open space (voids). For example, Figure 1-3 contains drawings from Sir Leslie Martin's land use and built form studies at Cambridge.¹ Each built form model shows how massing can occur with an identical FAR of 4 (a floor area four times the site area). Martin's purpose was to show which forms provided the best internal daylight for developing office structures. Yet other questions could be asked. Which built forms would be least expensive to construct? Which would be most energy efficient? Which would have the lowest life cycle energy costs? Which would best accommodate unobtrusive parking? Which would be the most pleasant to walk among? Which would be the most formally dramatic from an architect's point of view? Which would be the most intimate from a layperson's point of view? Which would provide the best cost/benefit investment ratio from a municipal government point of view, and so on. The questions appear limitless and difficult to answer. Yet the answers are at the heart of resolving the issues surrounding intervention in existing urban contexts.

Given this awareness of the breadth and difficulty of the topic, we will use the built space/ open space conceptualization to examine the urban physical planning models presently in use. We will review the following models: "Block City," "Garden City," "Radiant City," "Superblock City," and "Network City." Another model, "Broad Acre City" will not be considered because it is not relevant to urban settings.

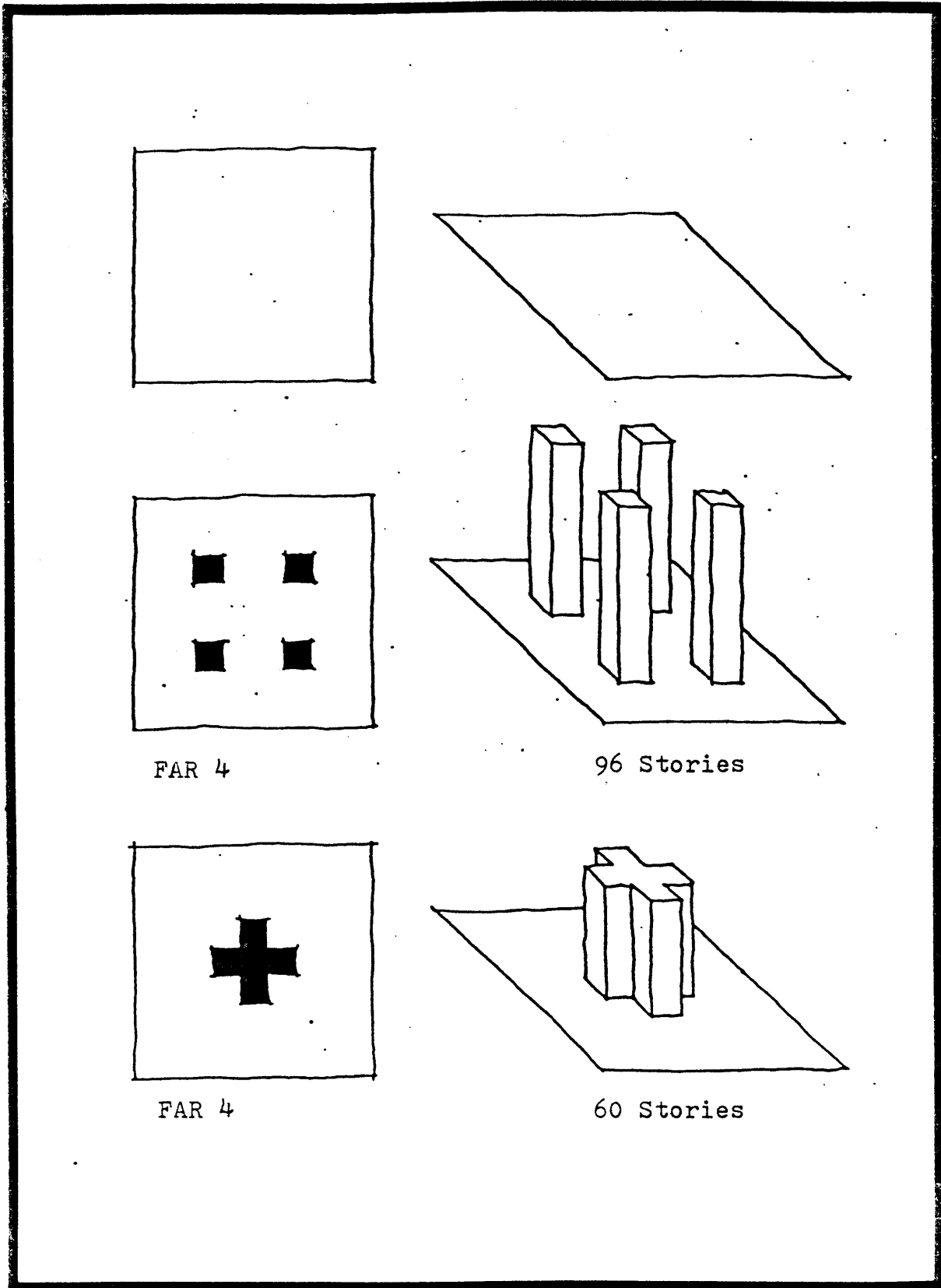
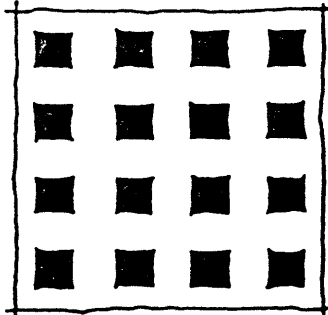
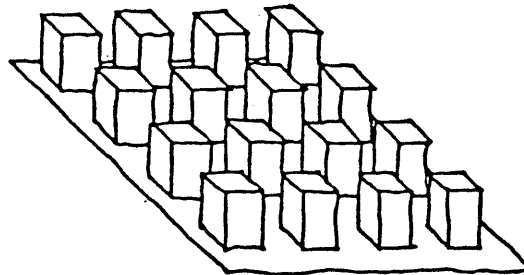

Figure 1-3



FAR 4



24 Stories

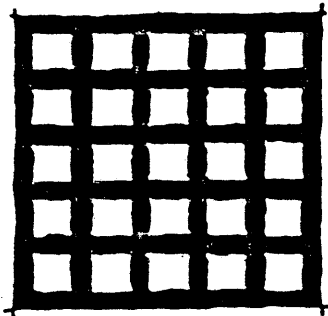

FAR 4

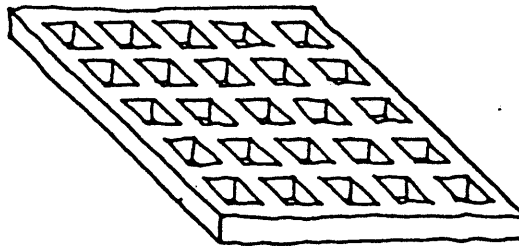

8 Stories

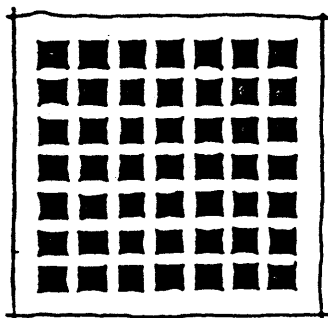

FAR 4

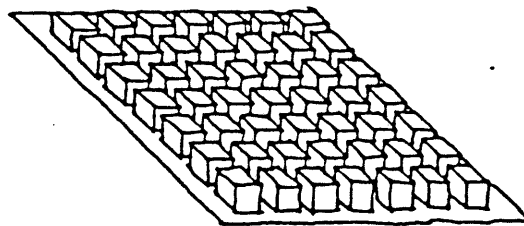

8 Stories

Figure 1-4

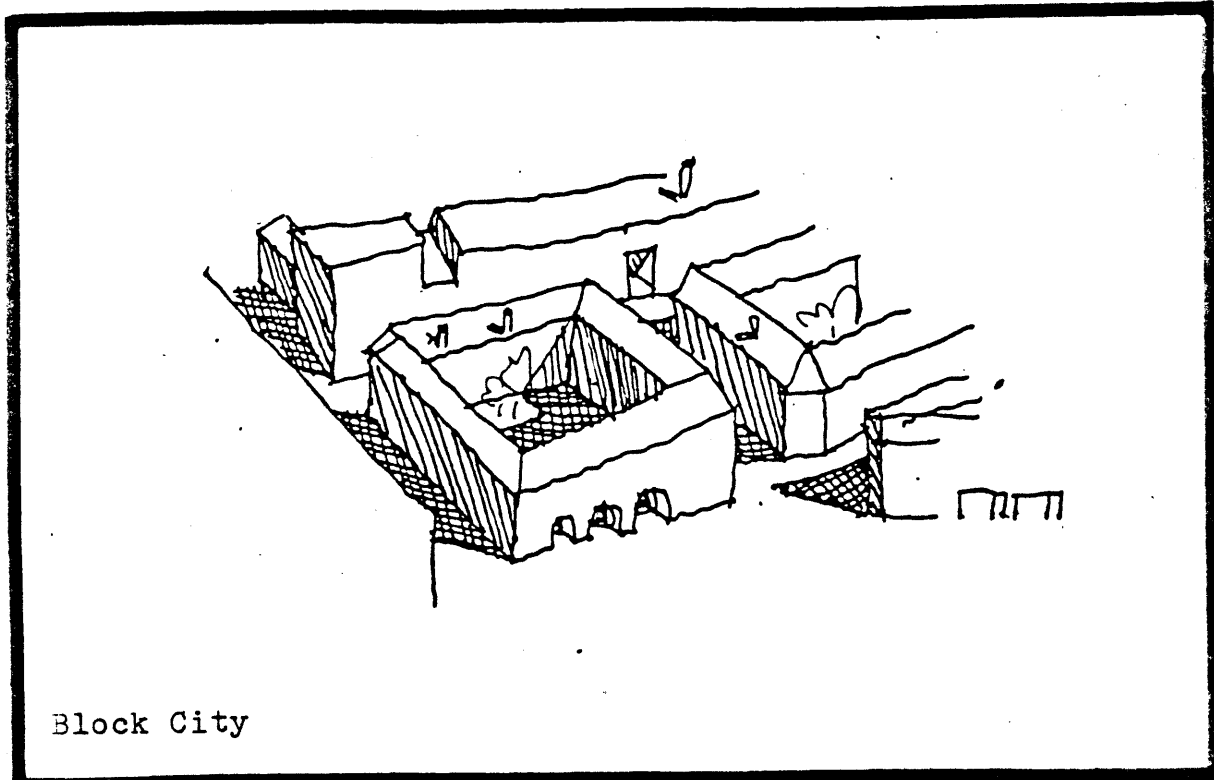

Figure 1-5

Block City

Block City began as a pre-industrial city. Compact and dense, it was a mosaic of mixed uses, including commercial, institutional, and residential activity. The city form could, in an abstract sense, be interpreted as a solid penetrated by voids (see Figure 1-5). Residential and commercial buildings were thematic, while government, religious, and public buildings were non-thematic. Within the residential areas there was often a variety of mixed uses.

This hierarchical, relatively dense, city form is found throughout the world in a variety of cultural and climatic conditions. Thus, a common pattern can be seen in the centers of Paris, Kathmandu, Kyoto, old Delhi, Peking, and Medina.

The great student of Block City was Camillio Sitte, a late 19th century Viennese architect of the Beaux Arts tradition who studied plans of European public open spaces to examine the relationships between built and unbuilt space in non-thematic urban areas. His particular concern was the siting of religious and municipal buildings in open public plazas.²

The most popular contemporary advocate of Block City and the street quality that it creates is Jane Jacobs. In her book, The Life and Death of Great American Cities, she speaks of the desirable aspects of pedestrian street life that come with Block City organization.³ Her city, New York, is the grandest example of Block City with its orthogonal grid still retaining the schematic organizational principles of the earlier medieval cities. In New York City, built space in mixed-use blocks are given form and organization by open-space streets.

Block City was always created in new colonies as an effort to organize the land for subdivision. The experience in the United States was no different. Block cities are common throughout the country, since they were laid out by land surveyors and maintained by pre-World War II subdivision and zoning regulations.

As planning and architectural professionals took an active role in physical development after World War II, Block City was systematically

destroyed in an effort to create the models sanctioned by professionals.

In the last decade, new academic interest in this built form model was awakened in the Contextualist school, with the theoretical work of the Krier brothers and the writings of Collin Rowe.⁴ This model's resurrection comes as an effort to reintroduce historical and cultural meaning into the city and still respect its need for pedestrian and vehicular movement with centralized economic activity. It is a model that does adapt well to the industrial organization.

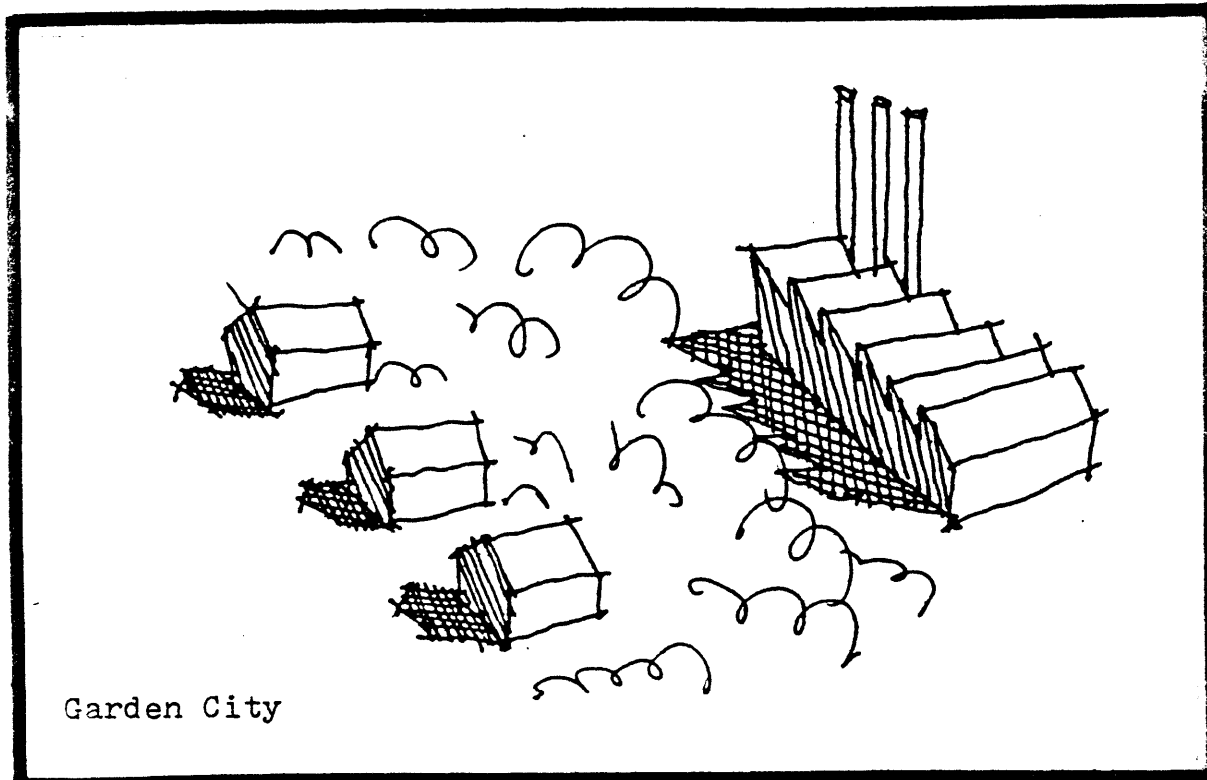

Figure 1-6.

Garden City

Garden City was an effort to ameliorate the impact of the Industrial Revolution on Block City, since the latter failed to adapt to the spatial requirements of industrialization. One of the early advocates was the English planner, Sir Ebenezer Howard, who started the utopian Garden City movement. In his physical concept of the city, new towns were to be created to alleviate the congestion of the urban centers. Industry and residential areas were to be separated in single use areas but within reasonable commuting distance (see Figure 1-6). The city was to maintain its hierarchical structure, but at

vastly decreased density. Land, according to Howard, was to be held in common.⁵ Early 20th century suburbs were based on this model through the Garden City planned by Clarence Stein and Henry Wright in Radburn, New Jersey. Use of the Garden City model led to the creation of large blocks, suited only for the automobile, with cul-de-sac streets and vast areas of semi-private open space located among the dwellings for semi-public pedestrian use. Central to the model is the creation of segregated movement systems and the destruction of the historic multi-use street.

In time, Garden City planning led to the restructuring of the dwelling's interior, since the living room no longer faced the street. Instead, it looked out on the semi-public open space at the rear of the building. Subdivision practices in suburban America in the 1950's followed the Garden City pattern religiously. Orthogonal block patterns of the 40's gave way to the undulating blocks and cul-de-sac streets, which created hierarchical patterns with cluster developments, causing the non-hierarchical patterns of the traditional Block City streets to be abandoned. Now patterns of Garden City are firmly entrenched in subdivision regulation manuals, and in the Planned Unit Developments (PUDS) that are developed throughout the country.

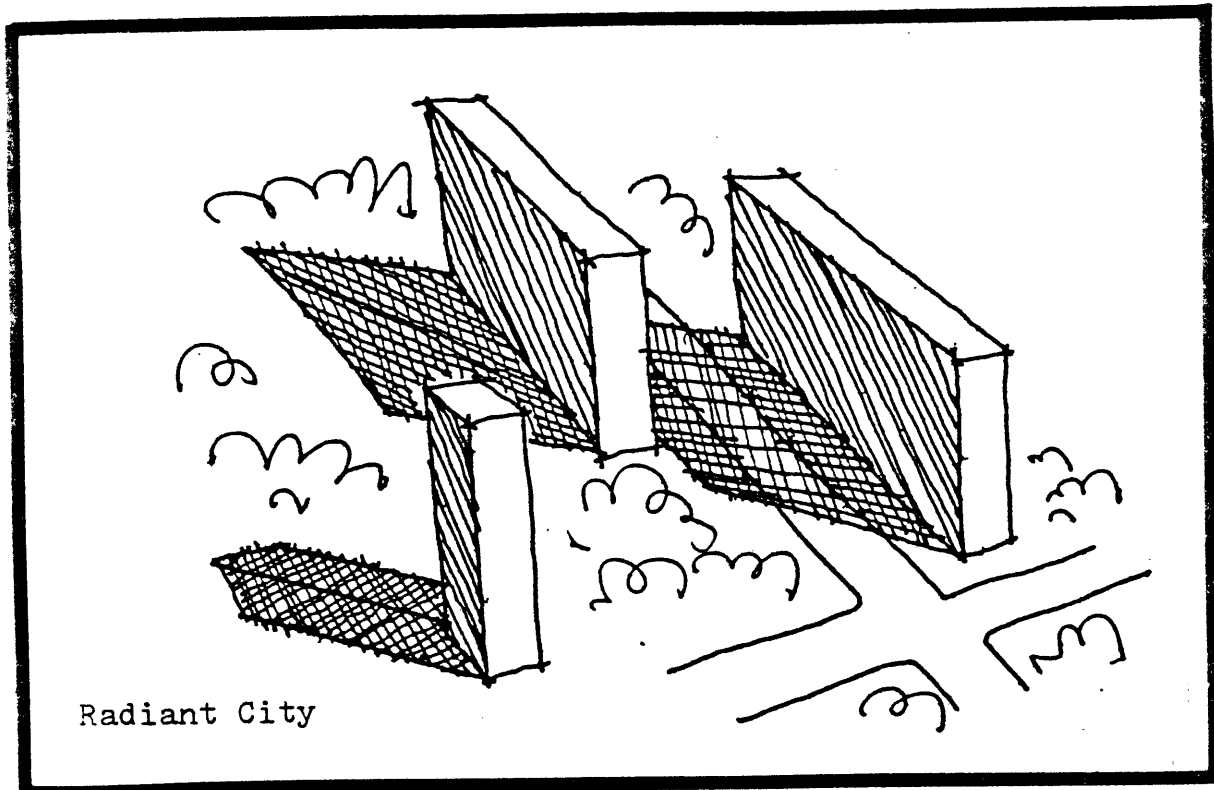

Figure 1-7

Radiant City

Radiant City is the premier utopian model of the 20th century. In some ways it is a magnified Garden City that provides for the automobile as the basic form of transportation (see Figure 1-7). The city is designed according to purely utilitarian standards as a reaction against the pre-industrial city's inability to adapt to the spatial demands of industrialization. The model calls for the massive destruction of the pre-industrial cities; it became the ideological basis for urban renewal in the American city during the 50's and early 60's.

Post-war American architectural training from 1945 through 1973 was largely based on this model. Le Corbusier, who in his drawings for La ville radieuse in 1922, gave the ideological framework to the new city form.⁶ His was a model which sought to consolidate housing in large apartment blocks which would permit the penetration of air, sun, and light into the apartment unit as well as provide vast acres of recreational open space to surround the apartment housing. Office work was to be incorporated in high-rise towers in central city areas. The car was accepted, and its movement patterns structured the city's form. All was planned for engineered efficiency.

The essence of the Radiant City viewpoint was expressed lucidly by Corbusier in his visit to New York in 1935: "The trouble with New York is that its sky-scrapers are too small and there are too many of them. The sky-scrapers are like little needles, all crowded together. They should be great obelisks far apart so that the city would have light, air, and order."⁷ Such was the spirit of Radiant City. Perhaps it has been realized in New York City's World Trade Center. To be sure, efforts to achieve Radiant City were made by practicing professionals throughout the world, most commonly by American architects in the urban renewal era and European architects in post World War II reconstruction. The most successful and comprehensive effort was in post-Revolutionary Russia which placed ideological emphasis on collective space at the expense of private space.

Radiant City still prevails in professional circles, even though

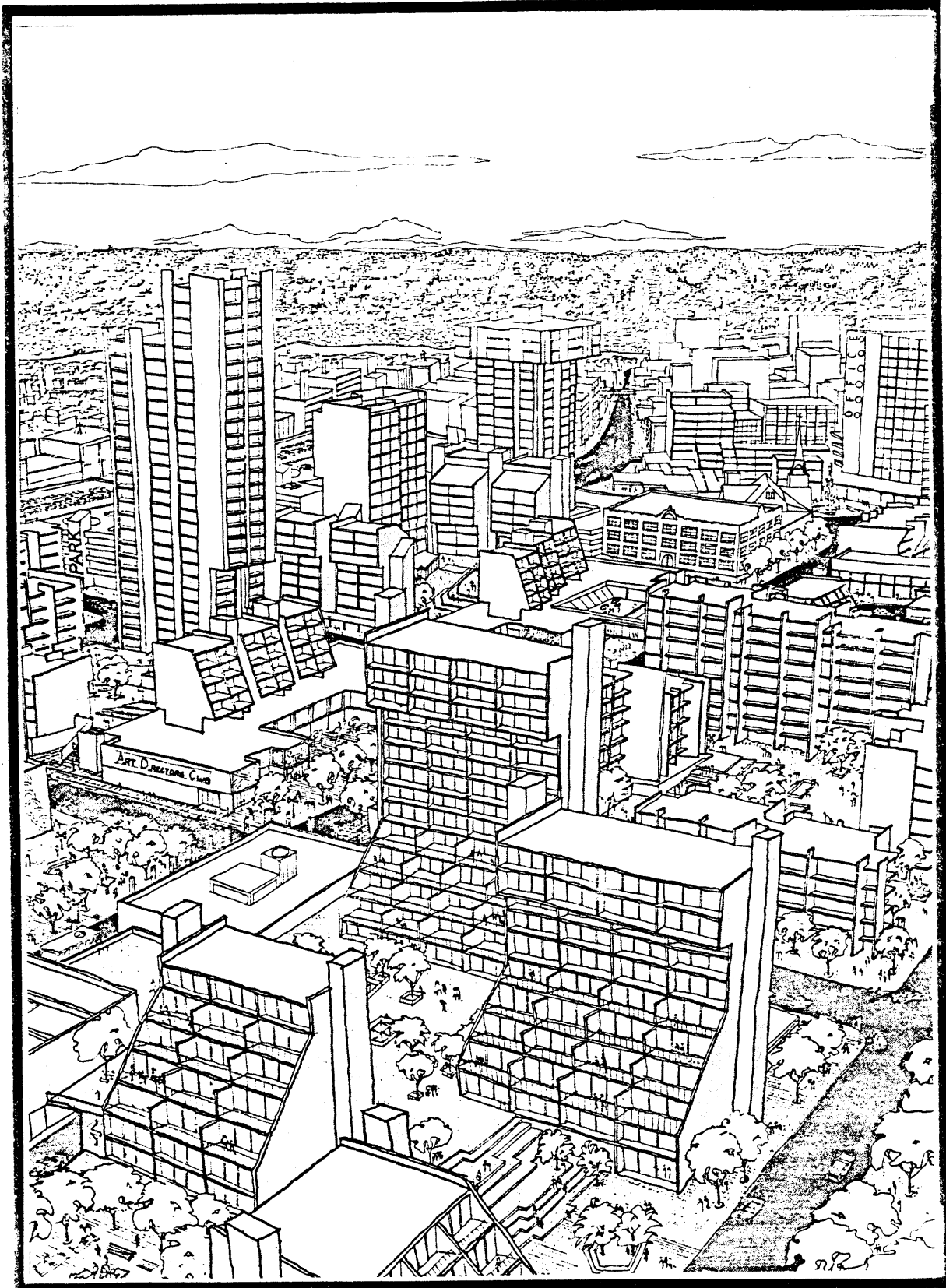

Figure 1-8.

the environmental conditions that generated the model have long since disappeared. Figure 1-8 shows a recent (1976) Radiant City civic image. It is a visual image that has been legitimized by zoning ordinances that give FAR bonuses to projects providing open space plazas at the buildings' base.

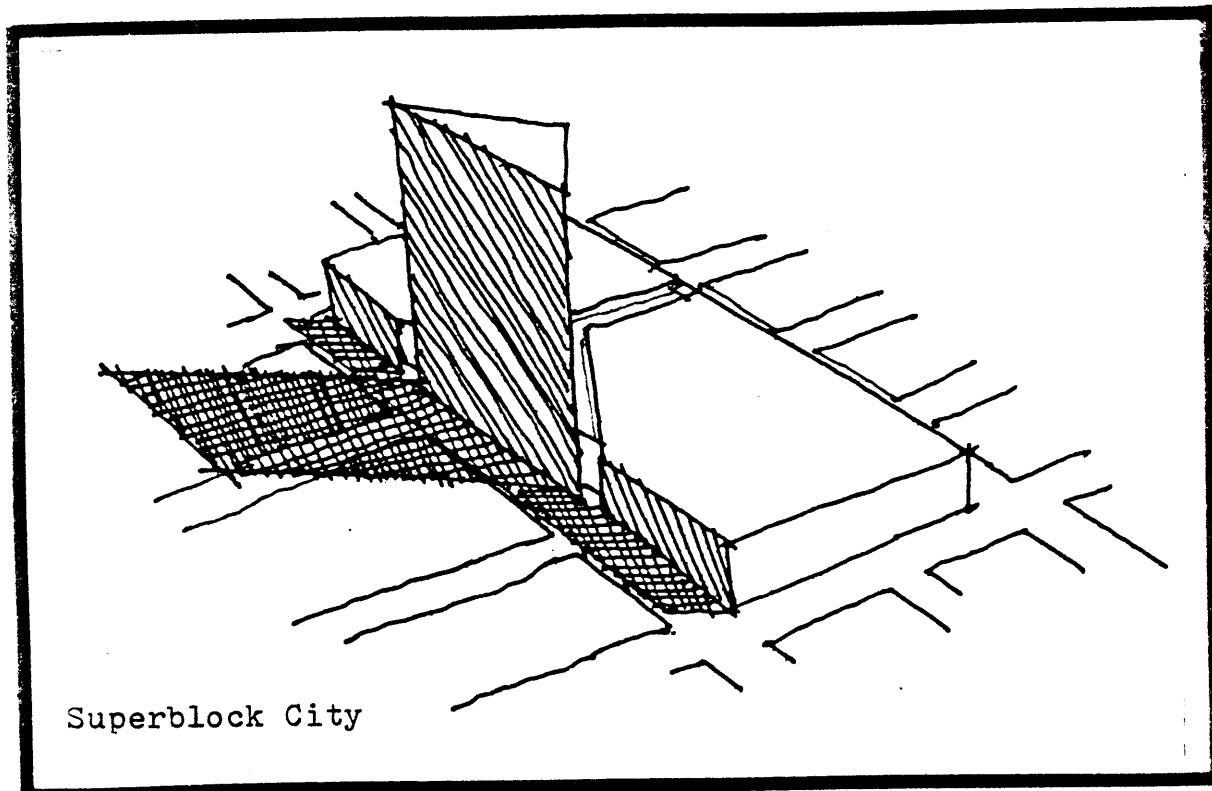

Figure 1-9.

Superblock City

Superblock City is a tentative model that is not advanced by any particular theoretician but was the natural outcome of commercial centralizations in corporate CBD's. Its principal characteristics include a concentration of mixed-use activity in clusters of multi-rise elevator buildings; the aggregation of several blocks via non-street related internal circulation patterns; the total separation of vehicular and pedestrian traffic in order to establish a pedestrian-only enclave; the development's indifference to its context; the use

of air and sub-surface rights for development; the convenient access to transportation; the need for great amounts of investment capital for development with necessarily long term risk; and the need for a large team of professionals to plan and execute the project (see Figure 1-9).

Examples of Superblock City exist in vestigial form in suburban shopping malls and in prototypical form in the Embarcadero Center in San Francisco, the Peach Tree Center in Atlanta, the Renaissance Center in Detroit, and the Crown Center in Kansas City. On occasion the Superblock City principles cover an entire CBD such as Houston Center in Houston or Oakland City in Oakland. In large cities such as New York, a Superblock City, such as Rockefeller Center, is simply contained by its larger Block City context.

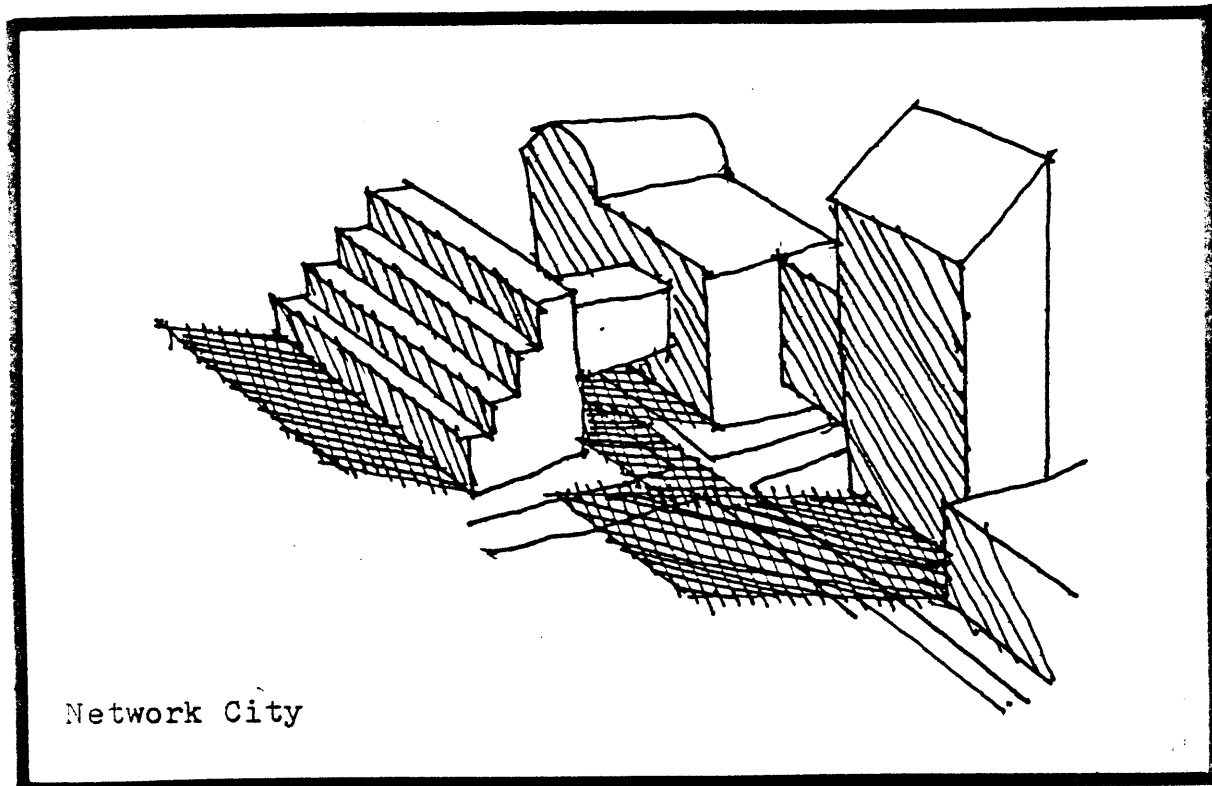

Figure 1-10

Network City

Network City is a speculative model with its emphasis on organized open space movement patterns at the expense of formal built space. Its origins come from the earliest efforts to separate transportation modes. Perhaps Venice is the most explicit example of Network City. Here islands as Block Cities were surrounded by water. Gondolas subsequently used the canals for commercial trade. Yet an entirely separate system of movement existed on land which bridged the water. Network Cities are now common in America, with the desire to protect

the pedestrian from the effects of the extreme climate and the pollution and other undesirable effects of car-dominated streets (see Figure 1-10).

Frequently Network Cities exist above grade. One example is the sky-way system in Minneapolis, which criss-crosses the CBD (see Figure 1-11). The establishment of the sky-way comes from the acquisition of air rights over the streets. Ultimately it works to remove pedestrian activity from the traditional streets of the older Block City.

Often the same principle works below grade. In Montreal, three square miles of underground pedestrian network exist. These emanate from the subway transit stops and permit the pedestrian to move about in an environment that is sheltered from the harsh winter climate, oblivious to the block pattern above.

In reality, all the city models exist piecemeal within most cities, varying in extent with the historical origin of given cities. East coast immigrant cities are largely Block Cities. New York is a giant Block City that embraces all the models. Boston is largely a Block City; Atlanta, Houston, and Minneapolis combine aspects of Radiant City, Superblock City, Network City, and Block City. Elliot Park, the inner-city neighborhood which is the focus of our study, has vestigial elements of all five models. In every case these city forms are the results of the ebb and flow of political, economic, social, and historical forces.

Only recently in our urban history have we seen the end of a period of national economic extravagance. For example, the federal government subsidized freeways that enabled the middle class to flee

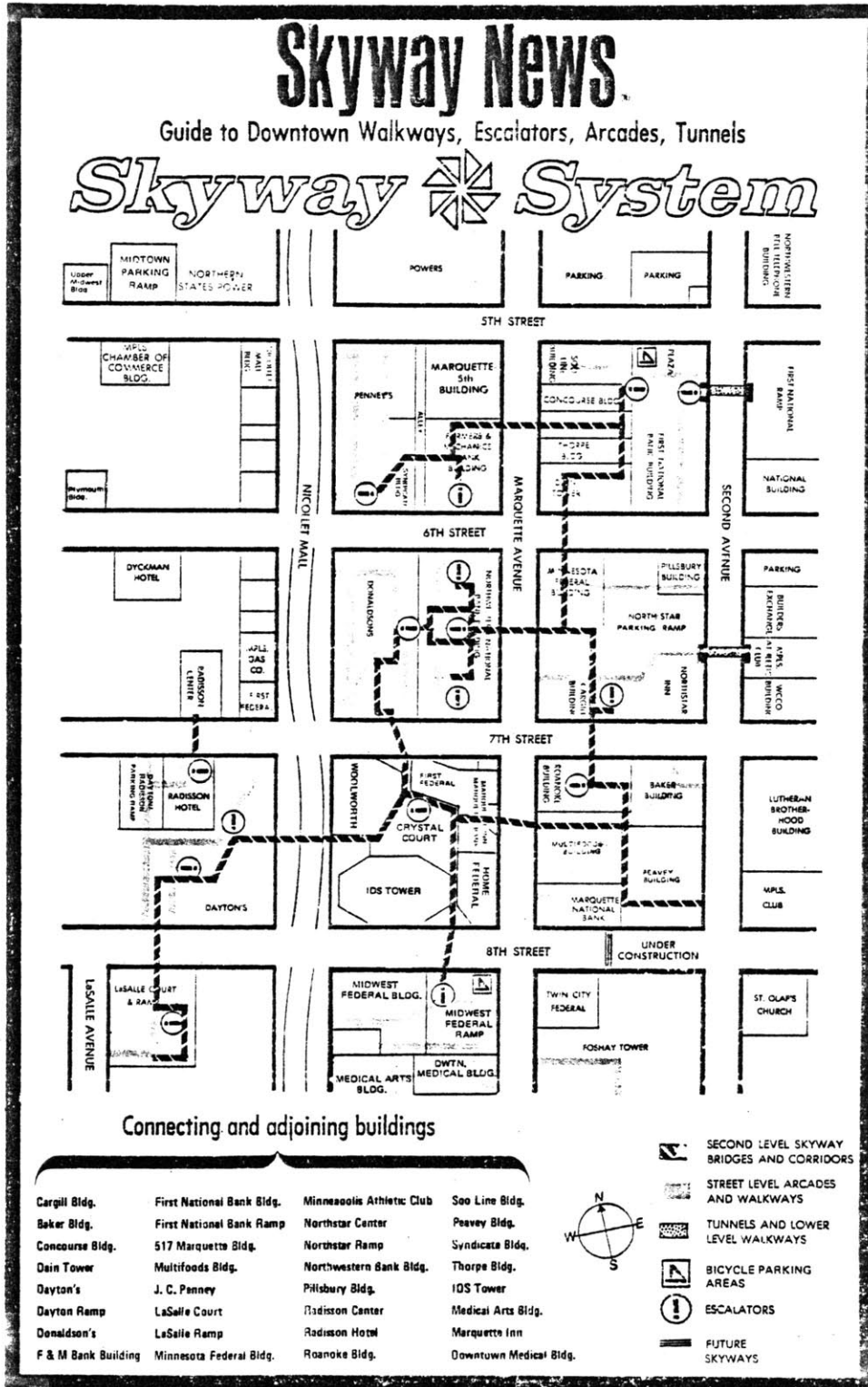

Figure 1-11

to Garden City suburbs; at the same time it subsidized urban renewal which encouraged the middle class to return to Radiant City high-rise towers in the inner city. The model for this urban renewal came from the Radiant City ideology and advocated replacing the older Block City with projects designed on the Radiant City example. A clear expression of this ideology is in the 1954 Sert plan for the extension of Barcelona (see Figures 1-12 and 1-13). Here the Radiant City is juxtaposed with the 19th century Cerda Block City plan.

With the current need for energy and capital conservation, we are looking at existing cities more respectfully and considering the necessity of recycling their uses. It would seem that one future role of the physical planner is to assist in putting the city back together again, to gradually build and incrementally change what is already there. It abandons the grand tabula rasa utopian models. It requires planning for incremental change, a process that has always made cities an unfinished mosaic of the past, the present, and the anticipated future. This is a process, recently rediscovered, that has been a part of urban settlements since the inception of cities, as shown in Figures 1-14 and 1-15.

But to engage in this recycling process, we need to be able to evaluate what is already there and make some judgment on its future potential. Issues need to be presented in a fashion so that those most affected by change can have a meaningful voice in its occurrence. We need methods to do so.

To develop such methods, we must understand what we have in the formal aspects of existing cities. One of the first efforts to

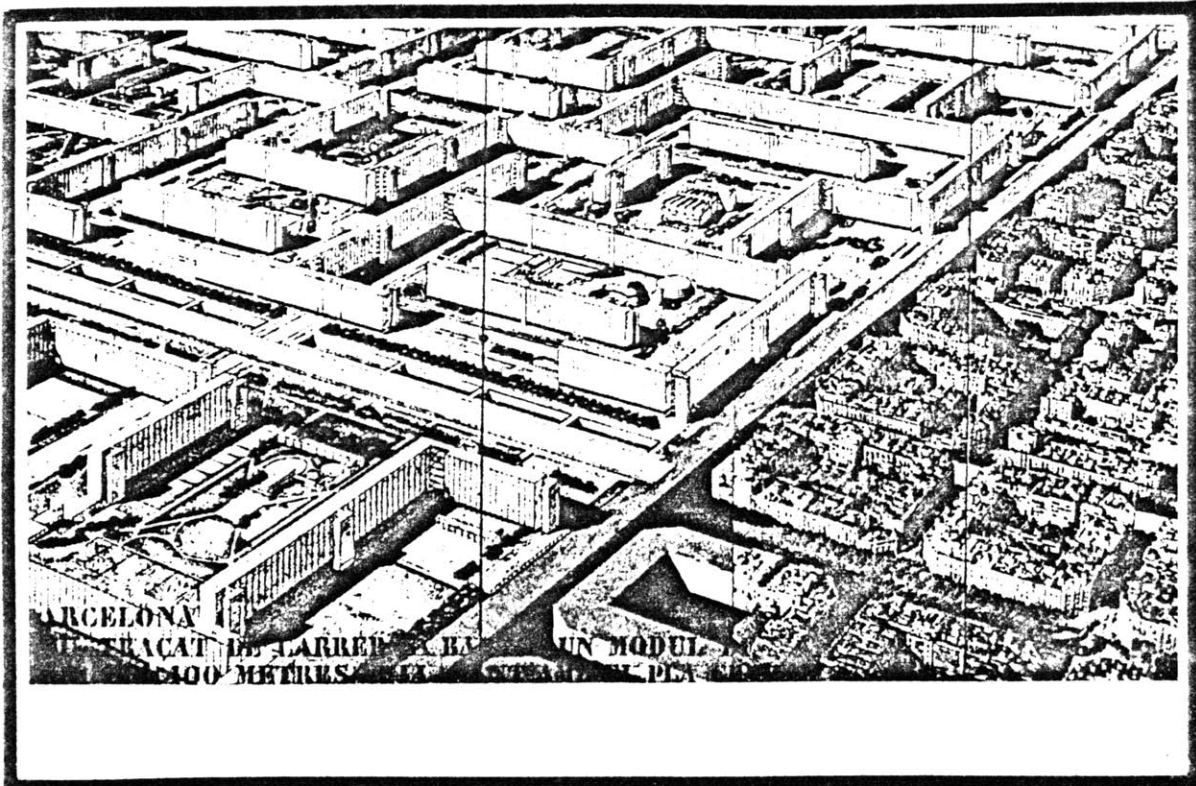

Figure 1-12

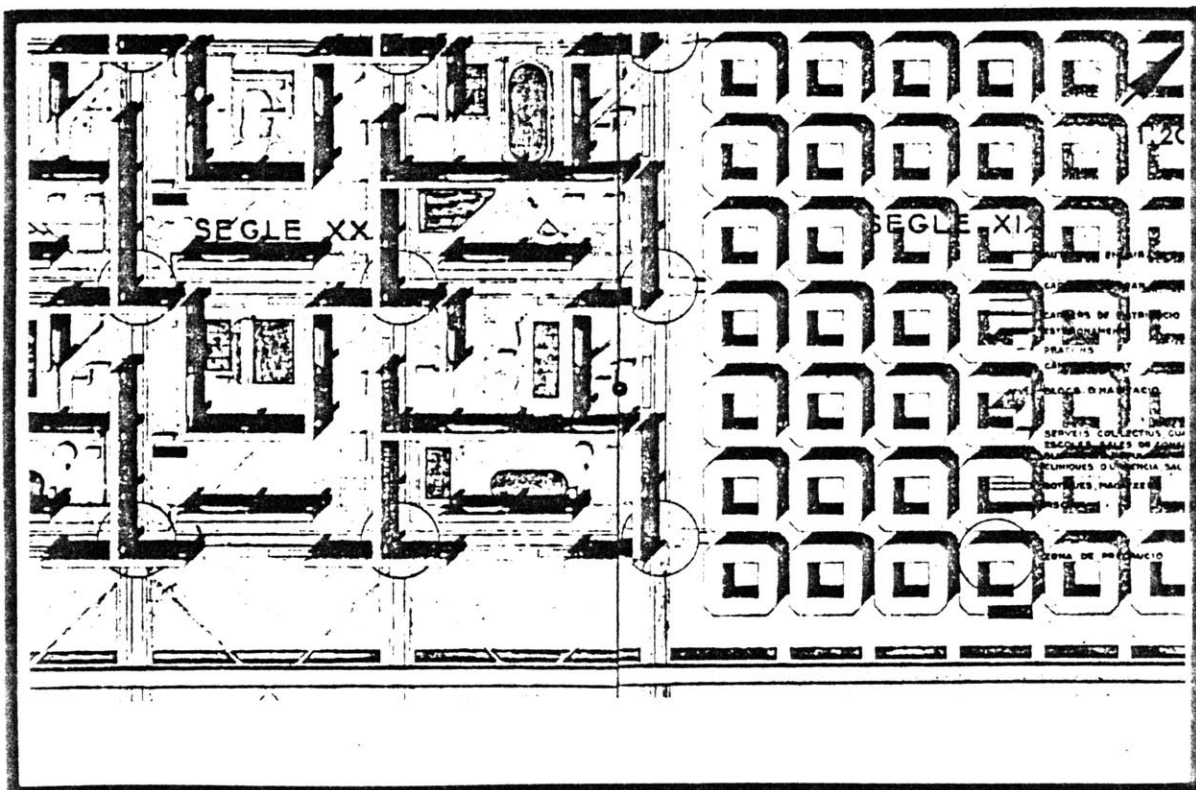

Figure 1-13

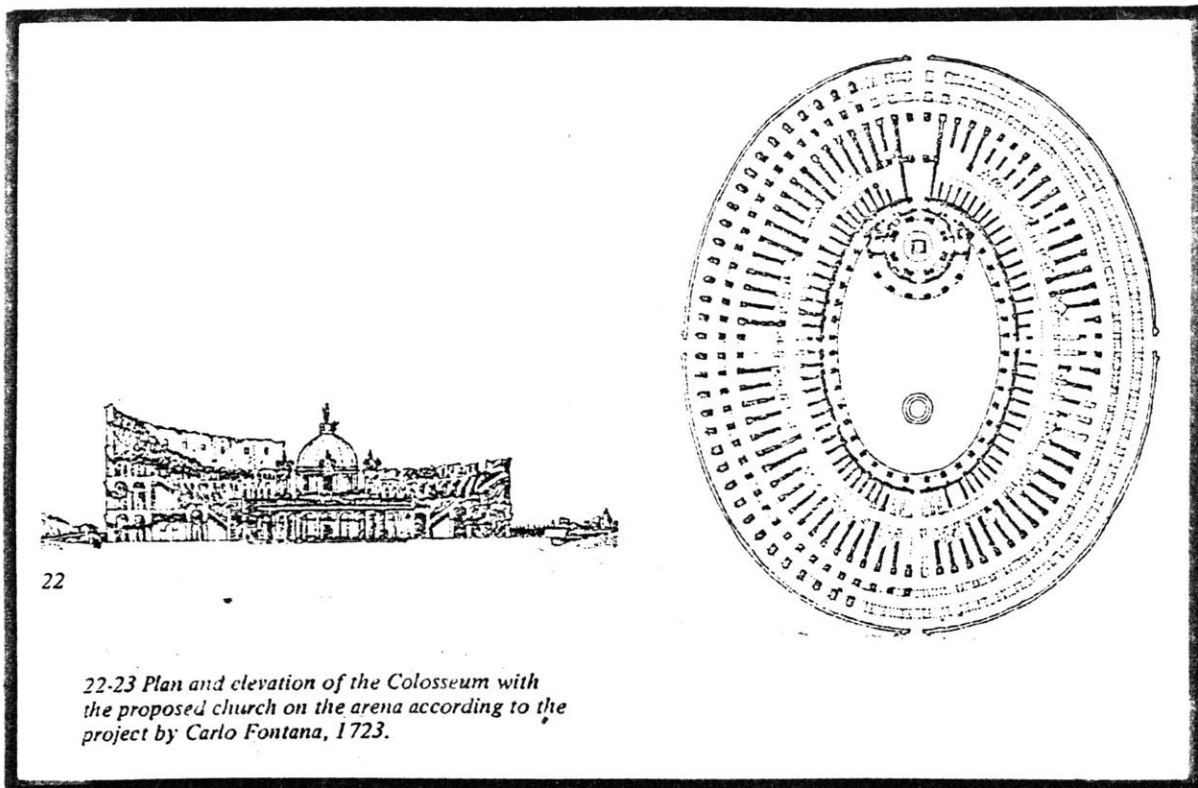

Figure 1-14.

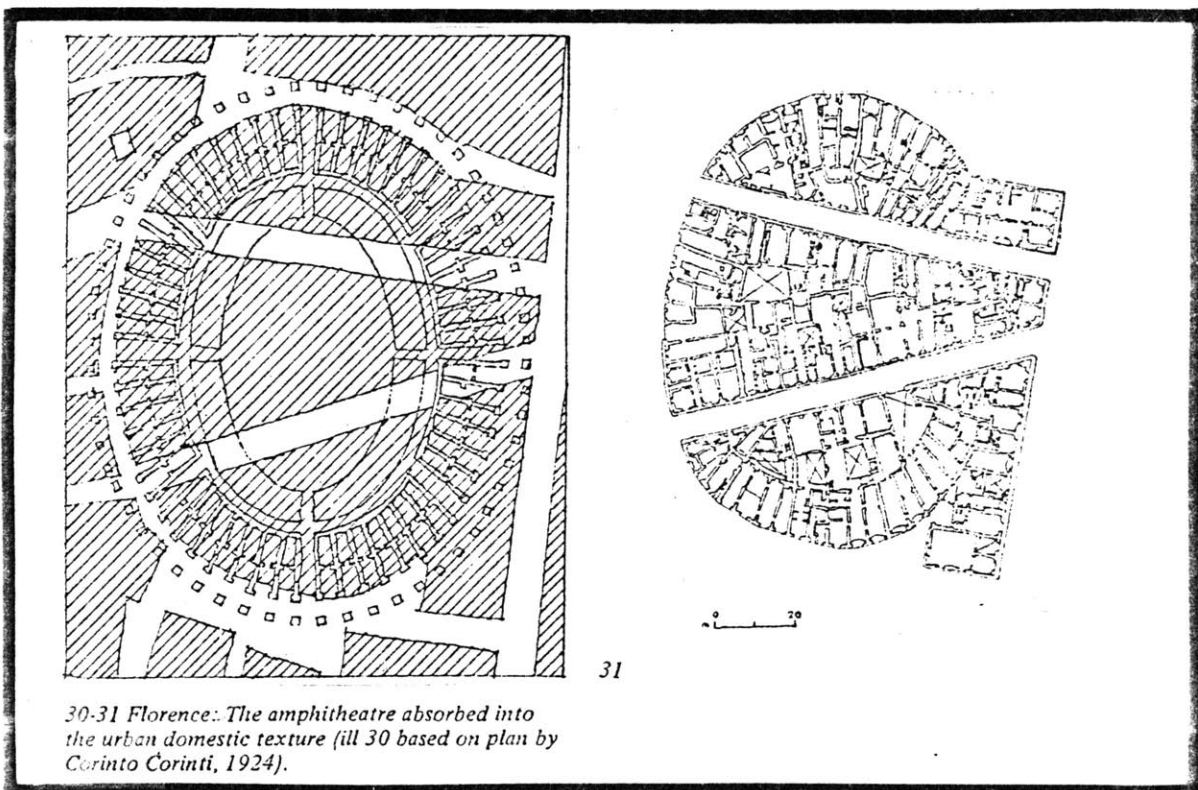

Figure 1-15.

develop a qualitative vocabulary for urban environments came from Kevin Lynch's book Image of the City. Here essential aspects of built and open space in three American cities were documented: Jersey City, Los Angeles, and Boston. A descriptive language was developed using conceptualizations such as "pathway," "node," "edge," "landmark," and "district," all based on an observer's sense of city form.⁸

In this thesis we will concentrate on the idea of district. When describing district, Lynch referred to a common physical quality, scale, material, sense of structure, and consistency of function. In a word, the environment was predictable and therefore comprehensible in orienting a person to the city.

While Lynch conceptualized the notion of district, John Habraken at the SAR in Holland developed analytical tools which would help to understand the physical and functional aspects of the idea "district." It was in the publication SAR '73 that these methodologies appeared after they were tested in analyzing the cohesive urban residential districts in Dutch cities.⁹ These test studies showed the usefulness of the methods to describe Block City organization. Assuming that the Block City model characterizes the majority of the world's cities, then one could say that the methods would have wide application in examining the physical characteristics of much of the global urban environment. Inferentially, one might assume that if the SAR '73 methods are useful in examining existing Block City contexts, they might be useful in examining the interventions within those contexts.

Our study methods will be based on these SAR '73 analytical tools. The following list summarizes the conventions that SAR '73 establishes:

1. Built environments are spatial systems of two elements: built space shown in black and unbuilt space shown in white (see Figure 1-16). Such environments are studied in plan view with buildings shown in black and open space in white (see Figure 1-17).
2. In examining built and open space elements in context, one classifies them by two characteristics, thematic and non-thematic, which describe the structure of any building district. Thematic built and open space are the repetitive elements in any district. For example, in a residential district of single family houses, the houses would be considered thematic built space, while the private lots would be considered thematic open space. Thematic built space is shown in black (see Figure 1-17).

Non-thematic buildings and open space are the non-repetitive, or the occasionally occurring, elements in any district. In a residential district of single family houses, a church, its yard, and parking lot would be considered non-thematic built and open space, or similarly, a school building with its playground would be considered non-thematic built and open space (see Figure 1-17). Non-thematic built space is shown in white.

3. In examining Block City model contexts, there are usually two forms of thematic buildings: the unattached Block City model which typifies residential neighborhoods in America with free-standing houses; the other is the attached Block City model which typifies residential neighborhoods with row housing, occasionally found in the United States, but most commonly found in Europe. SAR '73 was founded on this latter example, the attached Block City model (see Figure 1-18).
4. To see these relationships more clearly, it is helpful to see property lines super-imposed on built space/open space drawings. Then it is possible to see thematic units of built and open space in both unattached blocks and attached blocks (see Figure 1-19).
5. To describe the transitional area between built and open space, SAR '73 uses the convention of zone and margin (see Figure 1-20). On the left side of the figure we see two zones, the B and O zones as the described areas of built and open space. By defining these areas in zones it is possible to identify areas which have both open space and built space. These areas are referred to as margins by SAR '73. The O/B margin is shown in the left side of Figure 1-20. Zones and margins can be generalized in the following notation in the right side of Figure 1-20.

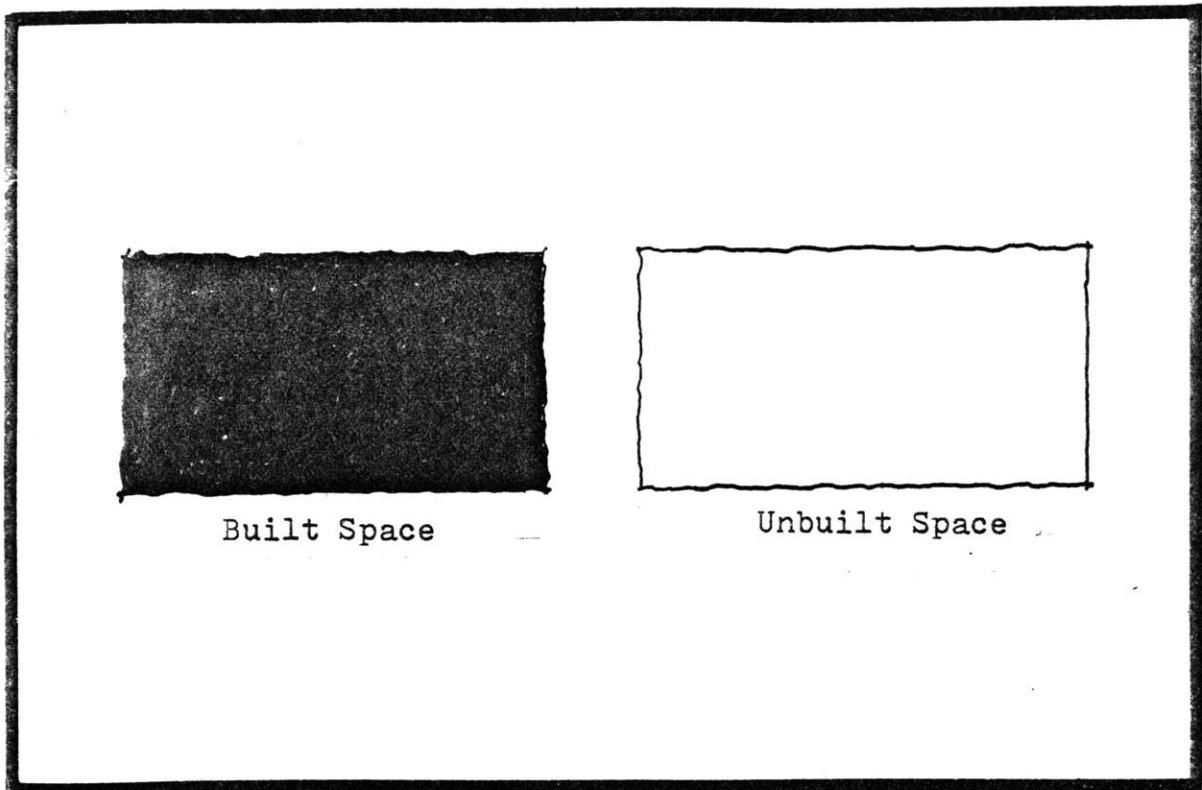

Figure 1-16

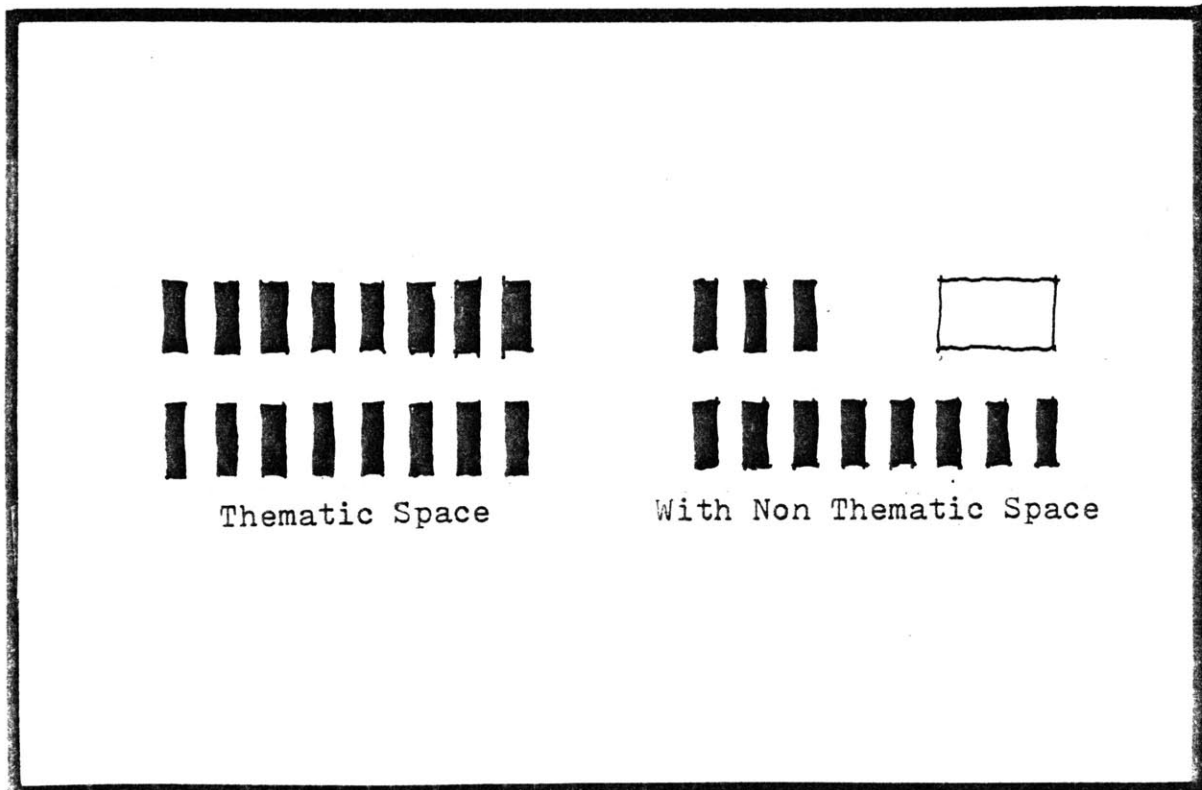

Figure 1-17

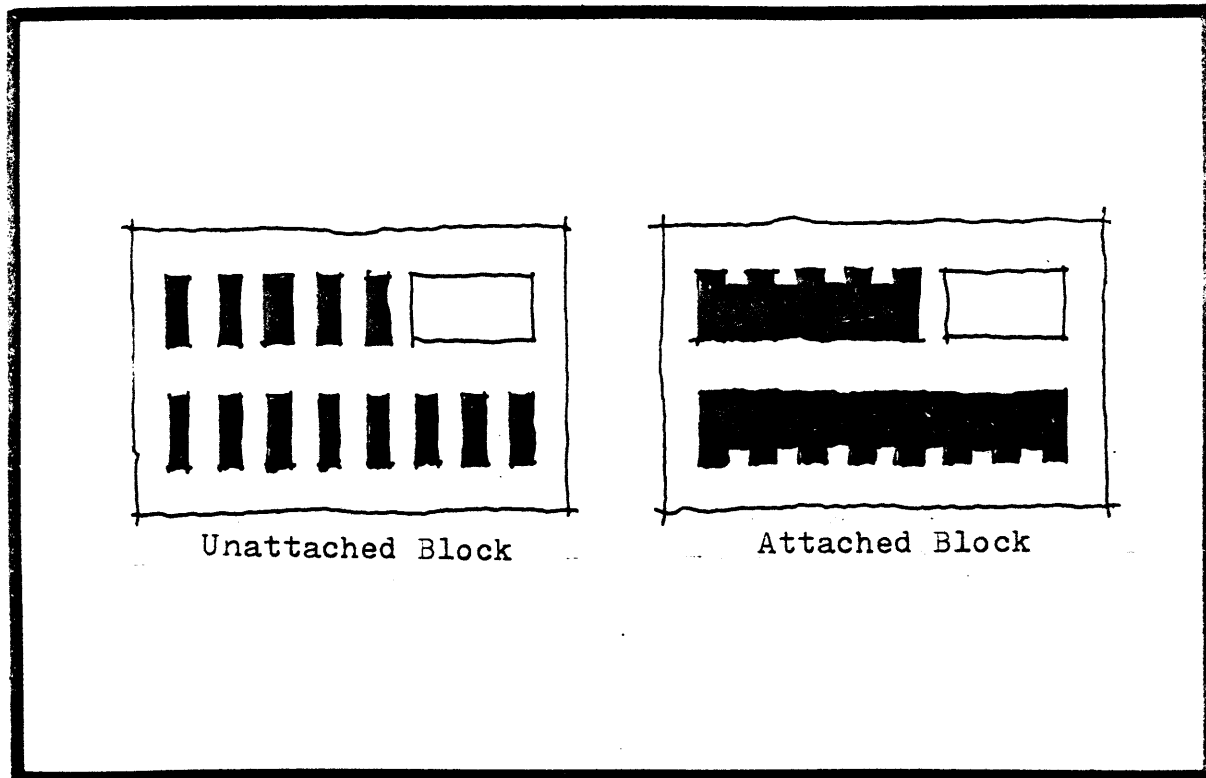

Figure 1-18.

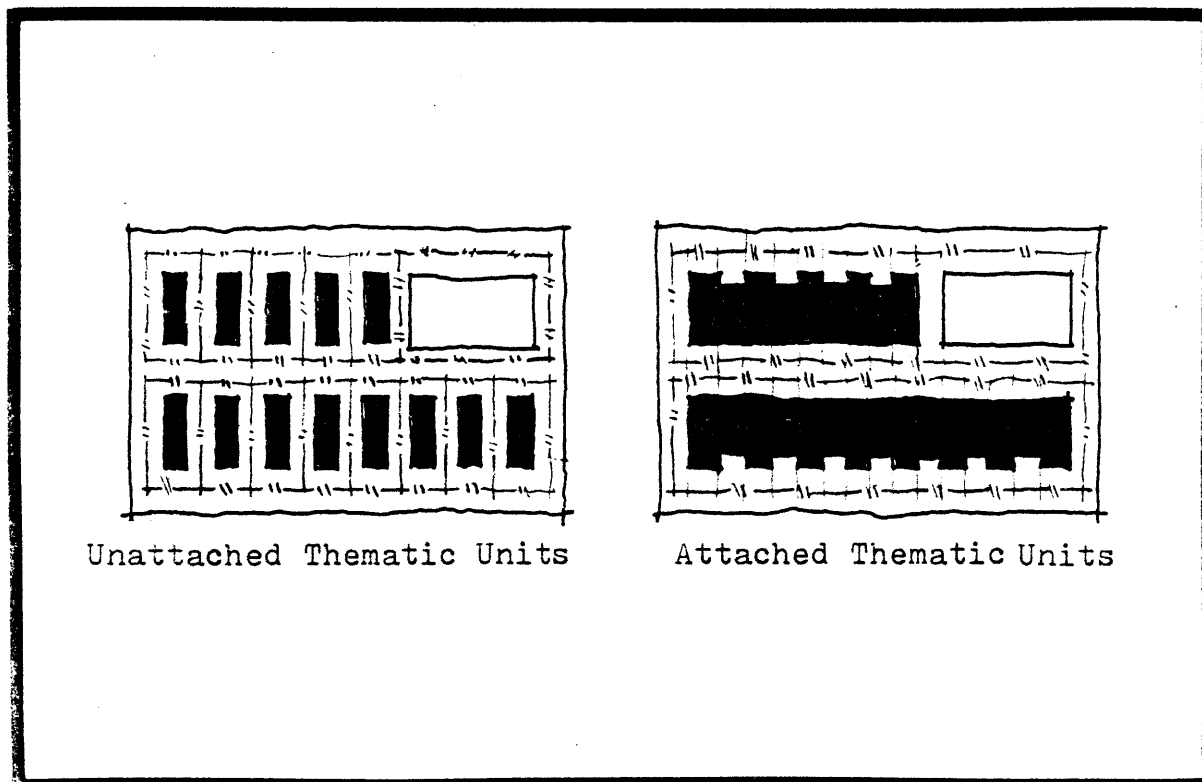

Figure 1-19.

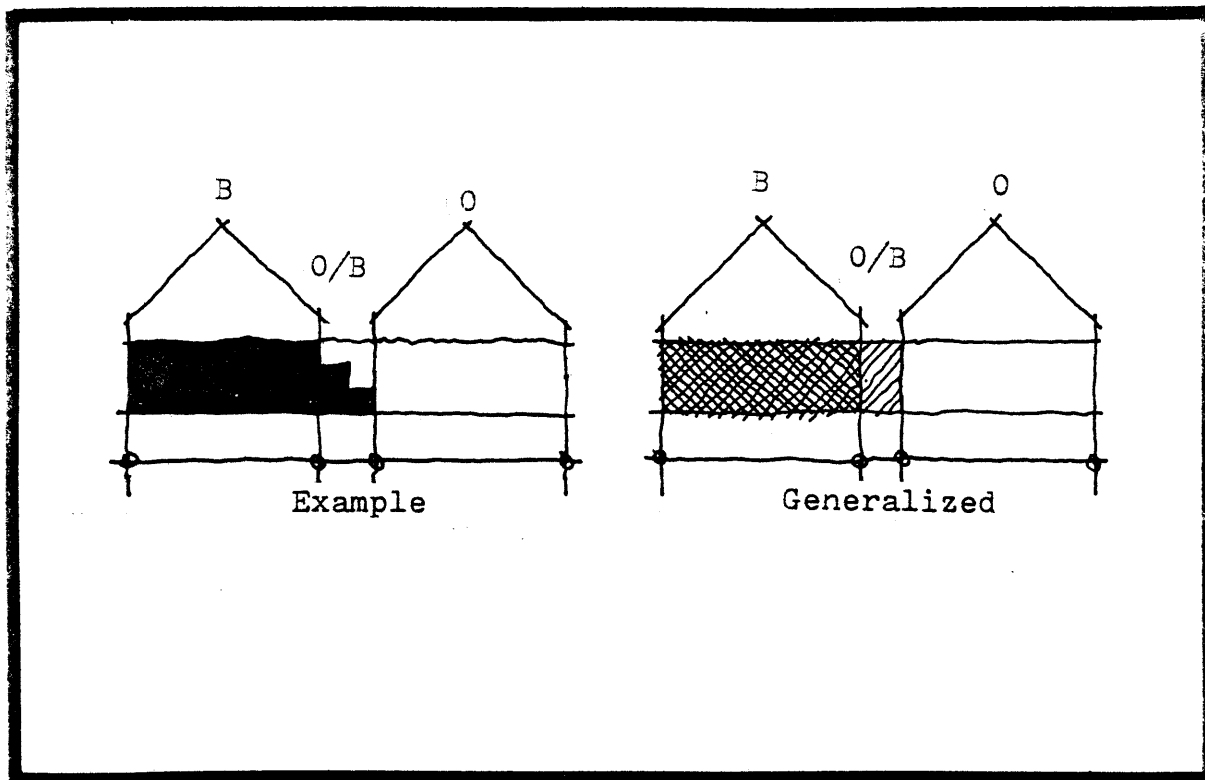

Figure 1-20.

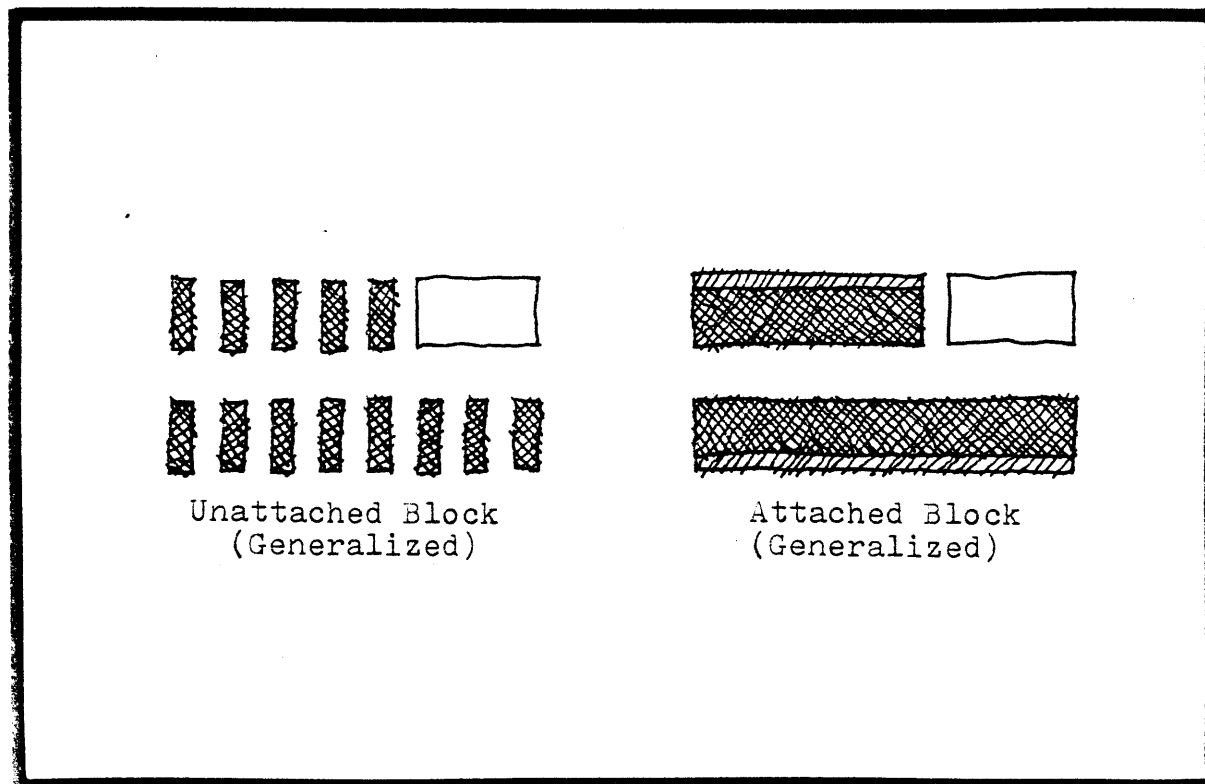

Figure 1-21.

6. The notational method used in Figure 1-20 can be used to study figure/ground descriptions of the Block City districts. For example, the blocks drawn in Figure 1-19 can be generalized into zones and margins as shown in Figure 1-20. The result of this process is shown in Figure 1-21.
7. Given this description of the built environment as a system of built and open space, SAR 73 looks at how (in a European context) power groups at different levels organize and control built and open space. These power relationships occur as a dialectic between context and site. Context always circumscribes and controls site; similarly site influences context. From this relationship comes an equilibrium between the higher powers and the lower powers that is achieved at a middle level, which often describes an environmental setting. This is best seen in the following example (see Figure 1-22).

At Level 5 a multi-unit apartment owner controls his land improvements (building) and all rental units within the apartment. This territory is the land parcel and the improvements made and changed under his ownership. At Level 6 another power exists--that of the renter. A renter who lives in the apartment can only control his furniture within the rented enclosure. Unlike the apartment owner, he can not move walls, move utilities, or make any physical improvements. These two powers find equilibrium with the apartment floor plan. Here the Level 5 power controls the plan, enclosure, and the utilities, while the Level 6 tenant only organizes his furniture. With changing needs, however, he may be able to influence the dwelling plan by asking the owner to alter it to respond to his changing spatial needs. Equilibrium then exists between these two powers with the arrangement of the furniture in the apartment unit plan.

The same situation exists for the Level 5 property owner who finds his power position subordinated to a higher Level 2 power (see Figure 1023). Here at Level 2 the city council via its power to determine the position and dimension of built and open space through district and performance zoning, restricts the property owner's use of his land. He can not make improvements (built) where higher powers will not permit building by creating zoning law which structures the open space that surrounds his potential building. Like the previous example, equilibrium is found between the power of the city council and the power of the property owner, which is described in the document called the site plan. The city provides the context for the site plan and controls the zoning law. The property owner can influence the site by seeking changes to the permitted improvements that he can make as a property owner. As in the previous example, the site plan provides a site for the building under the property owner's control.

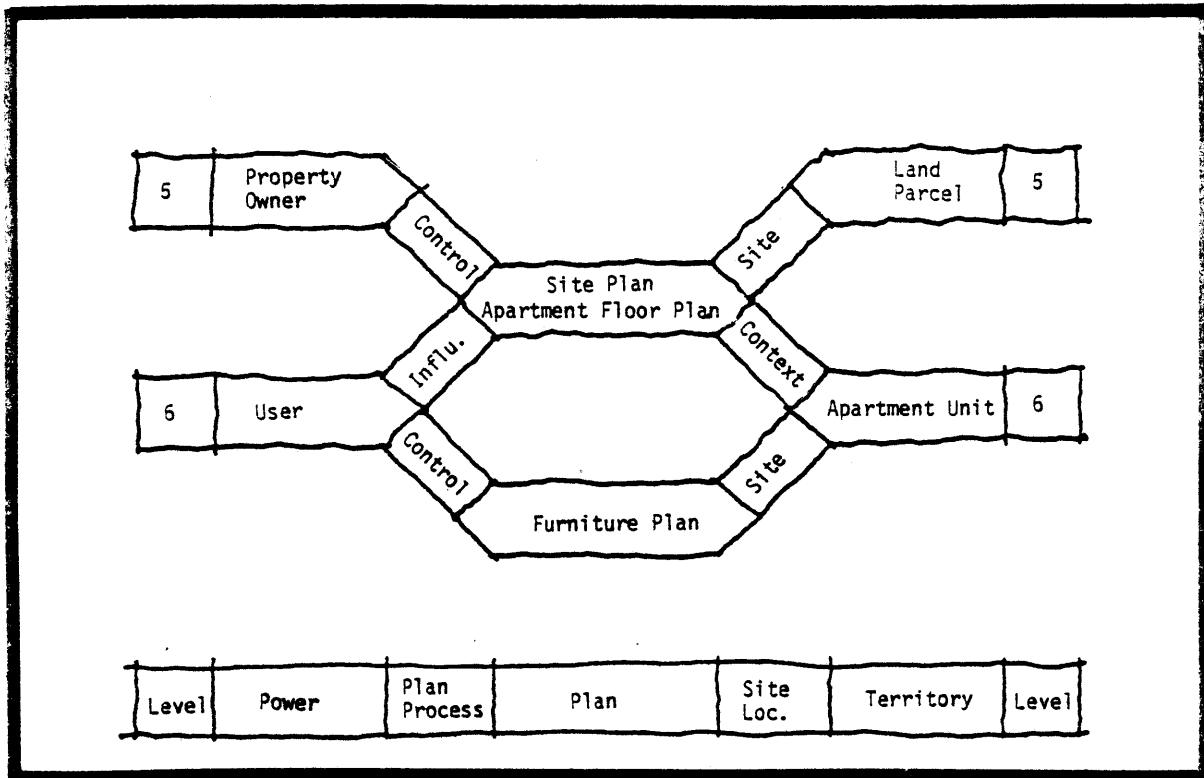

Figure 1-22.

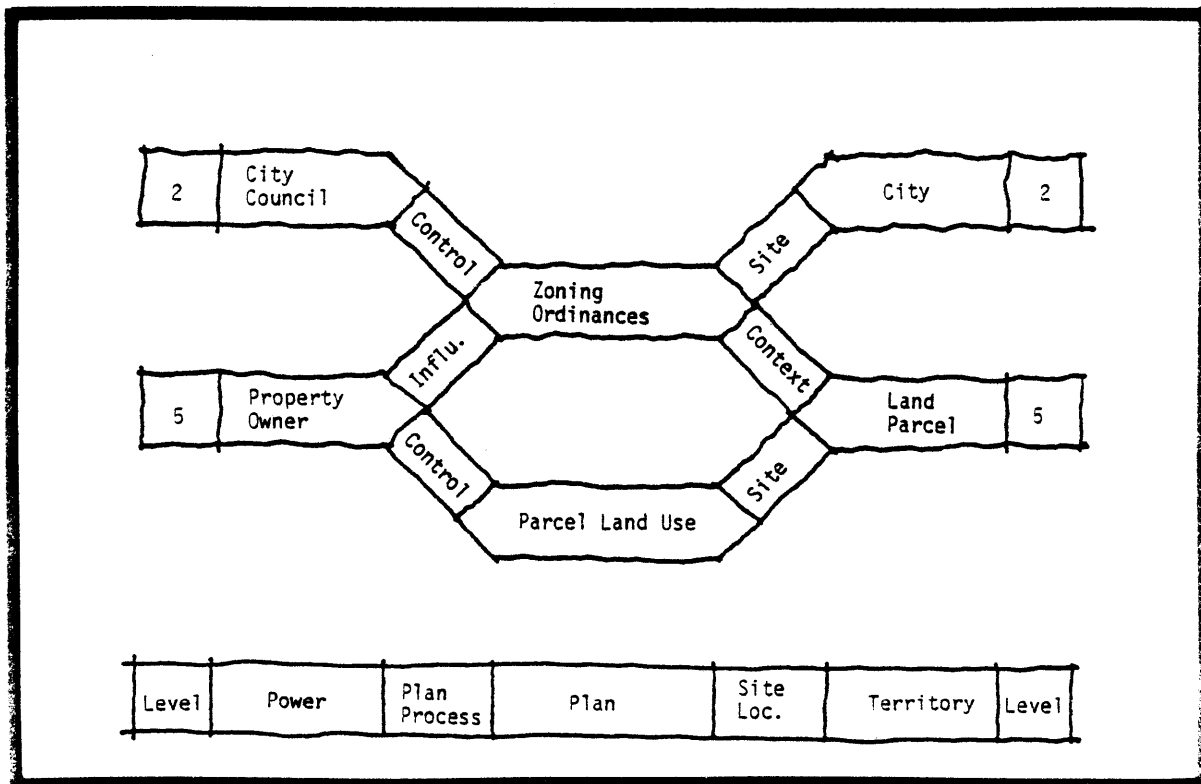

Figure 1-23

In the United States, the direct Level 5 to 2 power relationship exists universally (see Figure 1-24). However, in special circumstances, there are powers at the district level and the neighborhood level which act as refinements of the Level 2 requirements as they act on Level 5 activity. This Level 3 and Level 4 activity will be studied in the following chapters. It is a major argument of this thesis that these powers should organize and be heard more often in environmental planning. The most important thing to remember when examining a level diagram is to know what elements a power at a given level controls, e.g. furniture, land improvements, or municipal land use and zoning law.

The methods described are used by SAR '73 in this hierarchical land-use framework shown in Figure 1-24. The framework is best understood by reading along the bottom of the figure. It can be explained as follows. Levels describes the hierarchy of powers and territories. This territorial power and grouping will vary in different political and cultural contexts. The planning process shows how higher levels influence decision making above their level, while controlling decision making below their level. Plan refers to the agreements or equilibrium achieved by the different groups as shown in a specific document, known as a plan. Site location describes the plan in terms of its territorial situation in context. Sites of higher levels define contexts for lower levels. Last of all is the identification of territory which corresponds with the power group at the same level. Higher levels are shown by convention at the top of the page; lower levels will be shown at the bottom. The graphic methods shown in Figure 1-16 through 1-21 will be used to study existing districts at Levels 3 and 4 and interventions by parties at Level 5.

The SAR '73 analytical tools will help us in studying the notion of district and ultimately techniques for its preservation. In pursuing this study, there are several propositions to be tested:

1. Most people, given the economic and social opportunity, would like to live in a neighborhood with a strong sense of district. Such a district has strong connotations as reflected in the following quotation from Nation's Cities:

Nearly all of us choose to live in a neighborhood. It could be a few square blocks or a large city...or an old residential area of a smaller city...It could be a piece of the suburbs that has somehow established an identity that separates it from surrounding subdivisions. A good neighborhood is one that has special character. It can derive from the buildings, the street life, the commerce, its parks, or natural features, or the people who live there. Whatever the source of this character, it is something the residents feel and have an almost instinctive desire to preserve.¹⁰

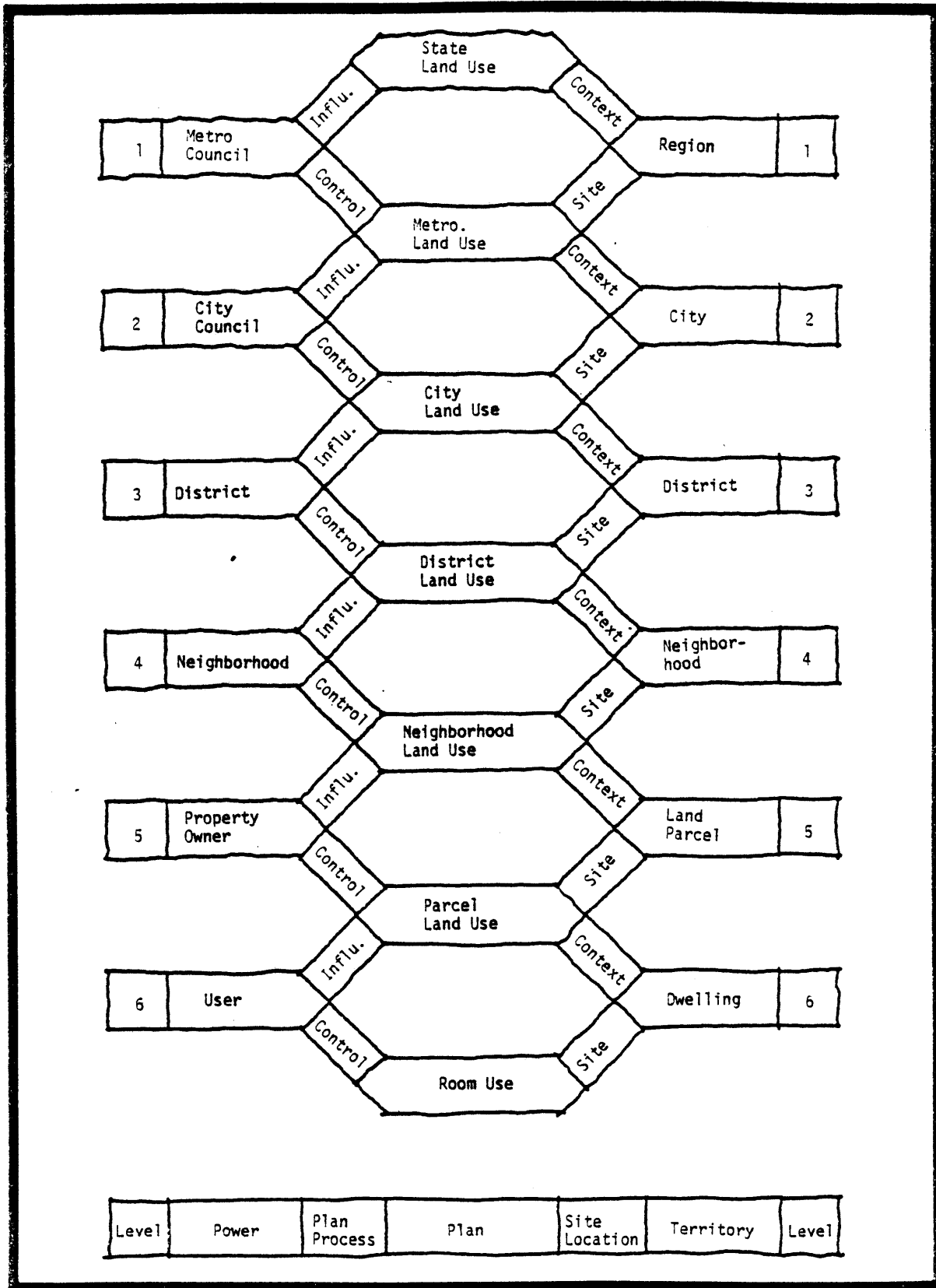

Figure 1-24.

2. If generalized district planning principles are broken down into understandable issues, people can be better equipped to propose or reject choices which impact on their physical environment.

3. Context design which develops a specific design solution around internal demands of the program and external demands of maintaining district is possible. This is contrasted with most architects and planners' interventions which are site-specific and based solely on concerns of internal programs.

4. A district cannot be maintained and protected from indiscriminate intervention without some form of specific contextual design control other than simple zoning laws. Such controls can be useful tools for both professional and laypersons.

To test these propositions, we will examine Block City districts in three cities: St. Paul, Boston, and Minneapolis. In St. Paul and Boston we will examine typical districts by looking at plan drawings, which will show the disposition of buildings and open space. This information will be analyzed using techniques derived from the SAR '73 methods. An analysis will show the disposition of thematic and non-thematic built and open space, the patterns of built and open space on a typical district block, and finally the levels and actors involved in maintaining district characteristics. The district in St. Paul will be compared to the district in Boston for areas of similarity.

In all three cities we will then examine five case studies to see under what circumstances interventions disturb or enhance district characteristics. This will be done again by examining plan drawings,

which will show the disposition of built and open space both for the district context and the proposed intervention. In addition, a level diagram will be examined in each case to see what actors and levels were involved in each intervention. From this study a comparative analysis of the cases will be made to determine under which circumstances district qualities were preserved.

For the focus of the study, Elliot Park, an inner-city neighborhood in Minneapolis, Minnesota, we will again use the same techniques as before to determine the existing district characteristics. Finally, from this data base we will look at three intervention situations and develop design guidelines which will encourage the interventions to become more compatible with district characteristics.

We will then summarize our study and explain how SAR '73 derived methodologies can be used as guidelines to assist neighborhoods in moderating new development to respect existing physical characteristics and to enhance the existing sense of district.

Chapter 2

Understanding District

To understand the morphology of a "district," we will examine two locations: one is a residential district that is organized around automobile travel; the other is a residential district with a higher density than the first and is organized around pedestrian travel. The two districts have much in common, which will be demonstrated in our study.

For our first look at a typical district, we will go to a Midwestern city, St. Paul, Minnesota, for an area that is at the junction of two of its first tier northern suburbs, Falcon Heights and Roseville (Figure 2-2). Our interest ultimately is with Falcon Heights, the older of the two suburbs and the first northern suburban extension from St. Paul. It is a stereotypic suburb characteristic of those built throughout the country shortly before and during World War II (see Figures 2-1 and 2-2). Housing here is American vernacular; it is the Midwestern equivalent of Mediterranean hill towns. Its pattern of open and built space is almost identical with that of the nineteenth century garden cities. Those who look at it from aerial photographs are inclined to consider its detached Block City layout homogeneous and monotonous; from street level, however, the environment is rich with a variety of details.

As we examine the area from the air at about 6,000 feet above sea level (scale 833 feet to the inch), we see an area of about 1.2 square miles (see Figure 2-3). It is a view familiar to all air travelers. Immediately we see large areas of thematic single

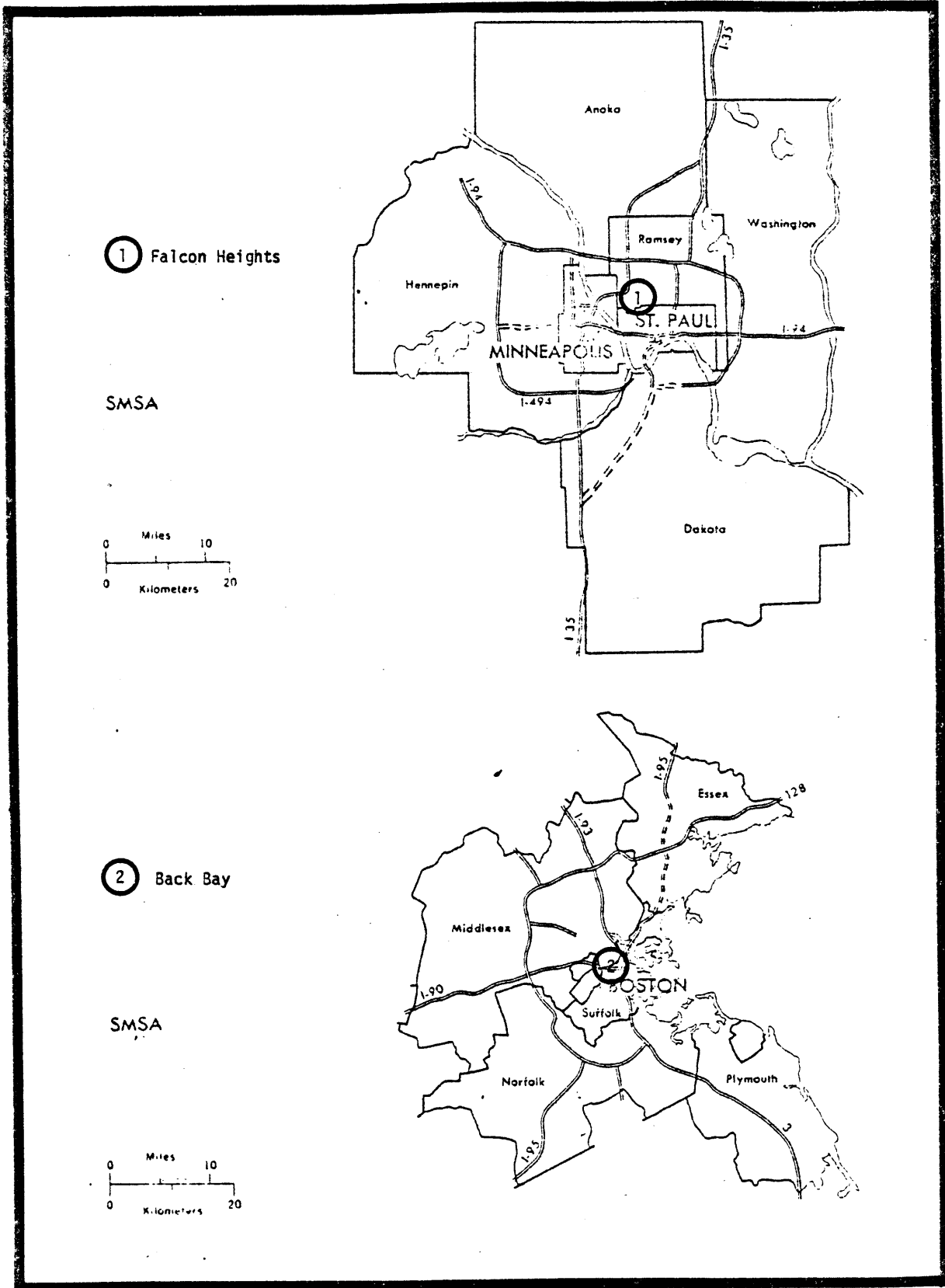

Figure 2-0

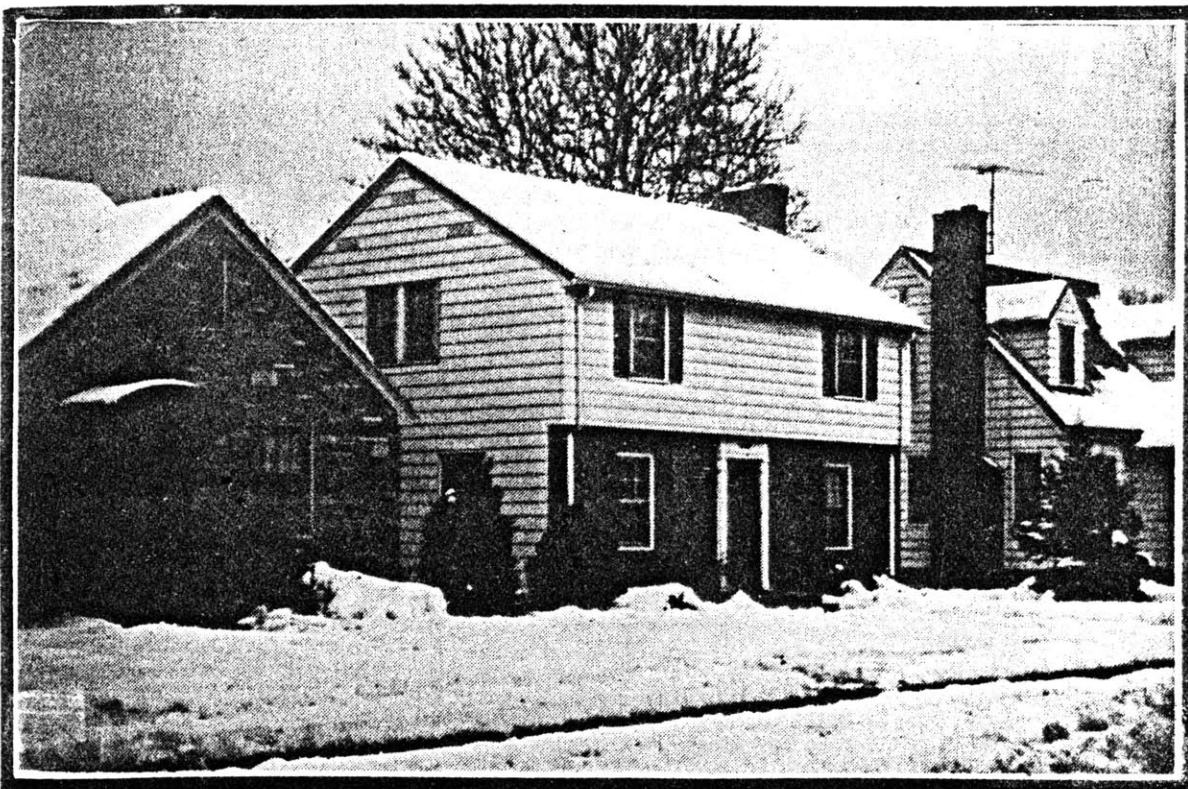

Figure 2-1.

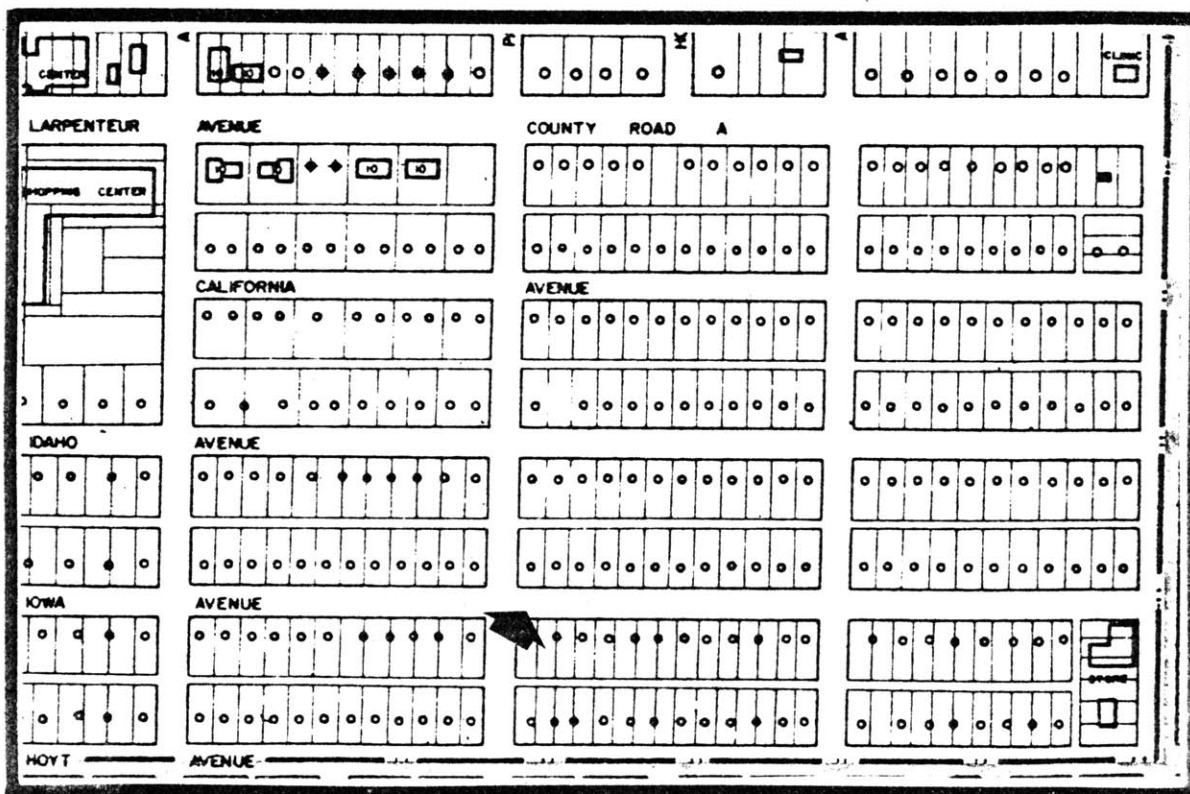

Figure 2-2



Figure 2-3.

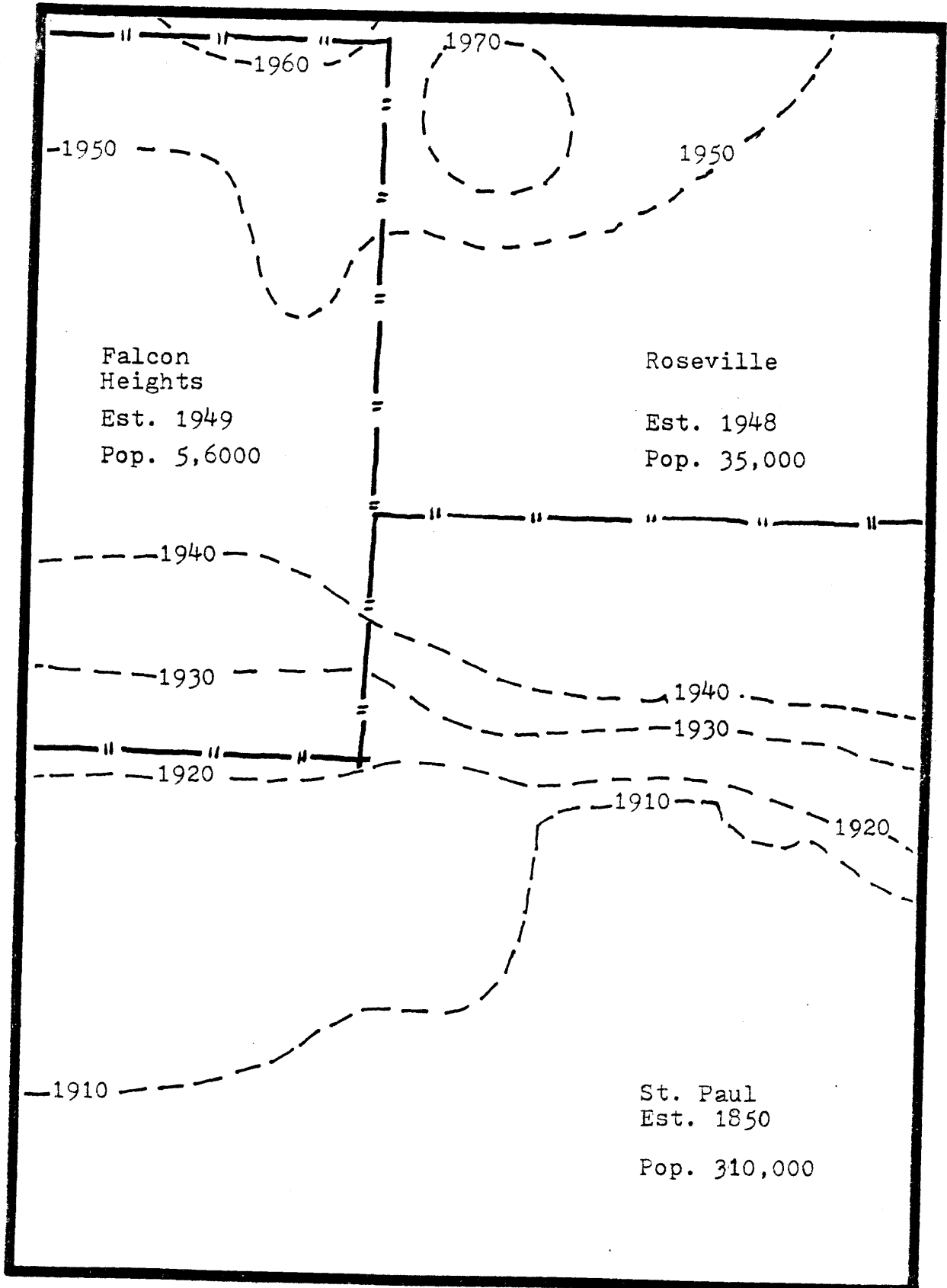

Figure 2-4

family houses (or "conforming" to use zoning administration parlance) with a seemingly endless gridiron pattern. Yet when one looks carefully, he sees non-thematic areas (non-conforming) interspersed within the block pattern. They are neighborhood schools and churches which are built as conditional uses in a residential zoning district. To the lower right is a large, non-thematic area which serves as a regional park to northern St. Paul neighborhoods. In the center of the photograph is the east-west arterial which serves as a northern boundary to our district.

In Figure 2-4, we see that the city growth rings were quite narrow at this location from the time the houses at the bottom of the page were built in 1910 to those at the top of the page built in 1950-- a distance of only 1.4 miles. Even vestigial pockets of vacant land were developed with housing as recently as the early 70's. Despite 50 years of housing development, the housing patterns are remarkably consistent.

Yet looking again carefully at the aerial photo, one can see several minor changes. In the years between 1910 and 1940, the sidewalks were abandoned with the growing use of the automobile. In the years after 1940, rear alleys were abandoned and replaced by kitchen-sided driveways leading to rear-yard garages. Around 1950, lots were platted wider and the garages were incorporated within the roof of the house, forming the single-story ranch house. In walking through the district in the car-oriented north, one fails to see the street activity that occurs in the sidewalked southern half of the district.

Figure 2-5 shows the built/open space morphology. Again the patterns are quite consistent; the black areas represent thematic built space and the white outlined areas represent non-thematic built space with greater size and different functional capacity than the single family house. At this scale it is difficult to organize the built space, so a look at the open space is necessary.

In Figure 2-6, the open space elements are shown, with the vehicular circulation patterns indicated to give organization. Again the patterns are clear; thematic open space circulation patterns surround the single family residential blocks and the non-thematic circulation patterns surround the non-thematic built spaces or, in the case of the regional park, non-thematic open spaces.

We can next demonstrate our morphological definitions (see Figure 2-7) by superimposing the built spaces upon the open space organized by streets. Immediately we can see the relationships that organize cityscape. Abstractly this shows a pattern shown in Figure 2-8. All the non-thematic built and open space is diagonally lined. The elements of the morphological system are built and open space, or, to be more accurate, built volumes and spatial voids.

We can not, however, ignore function. Figure 2-9 locates functional activity as a land use map with varying textures. Predictably, the non-thematic areas coincide with the areas zoned other than R-1 (see Figure 2-10). From this patterns of organization can be discerned, i.e, corner commercial shops, neighborhood school, and churches. These are located among the residential blocks, while

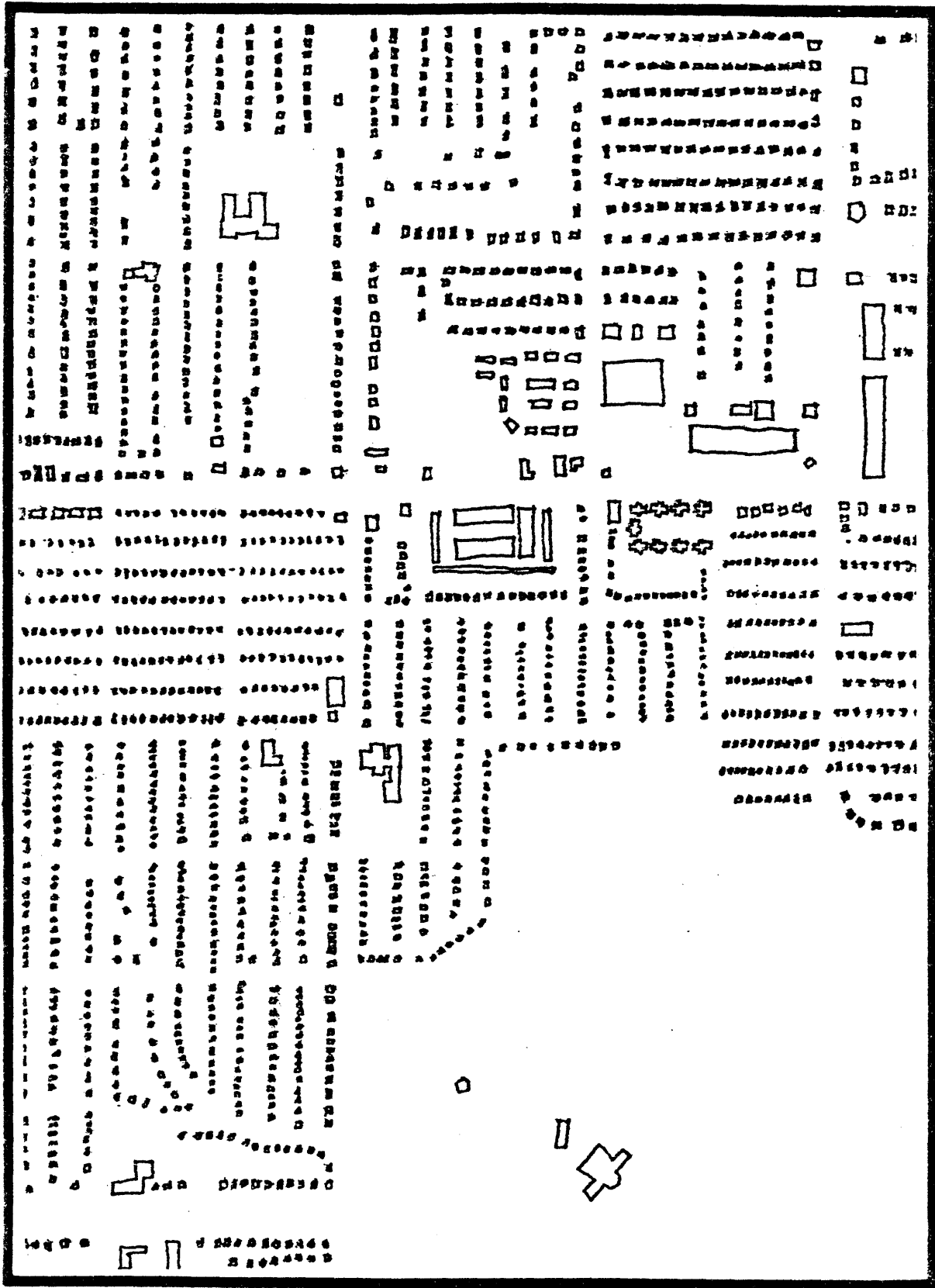

Figure 2-5

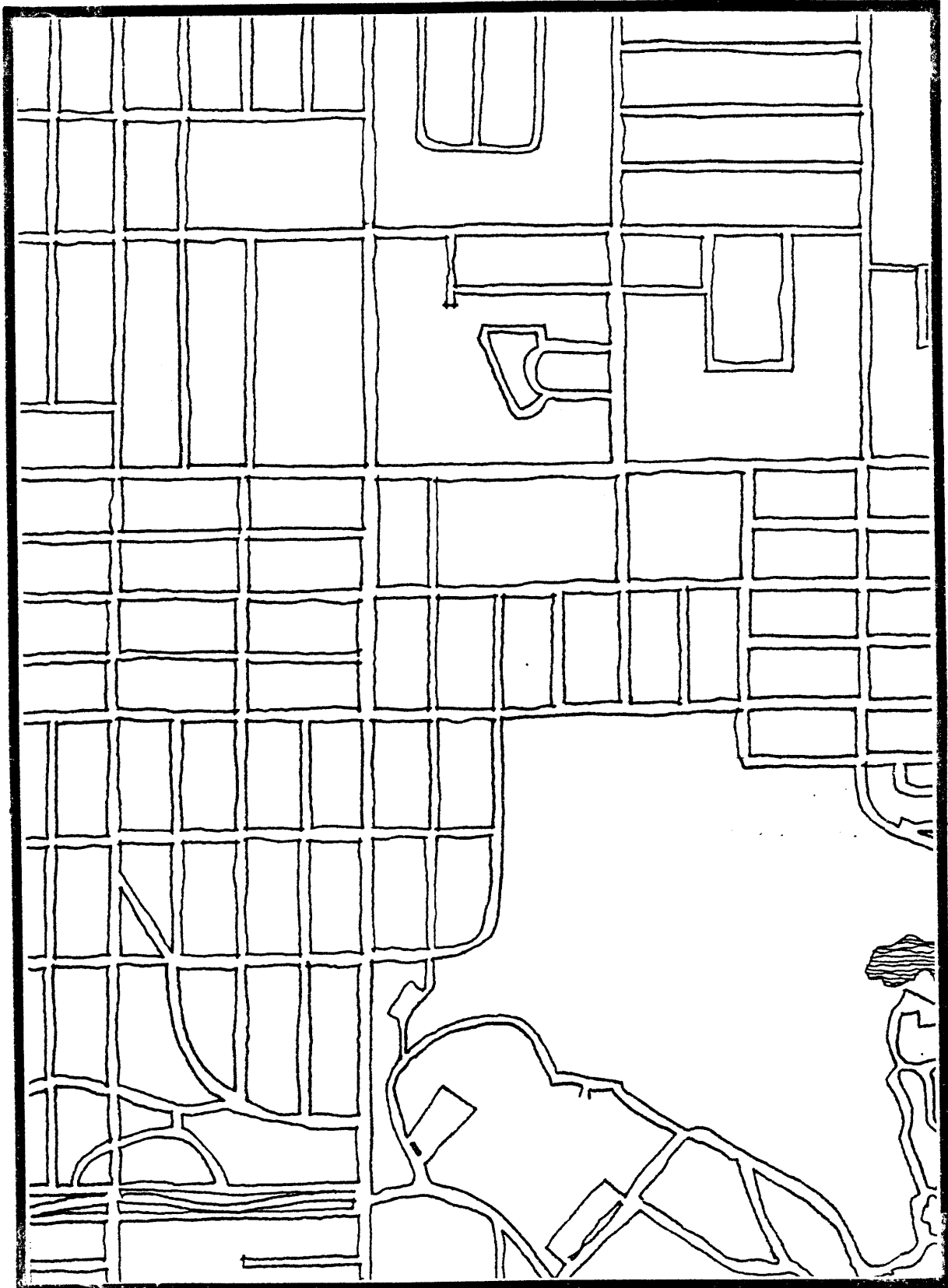

Figure 2-6

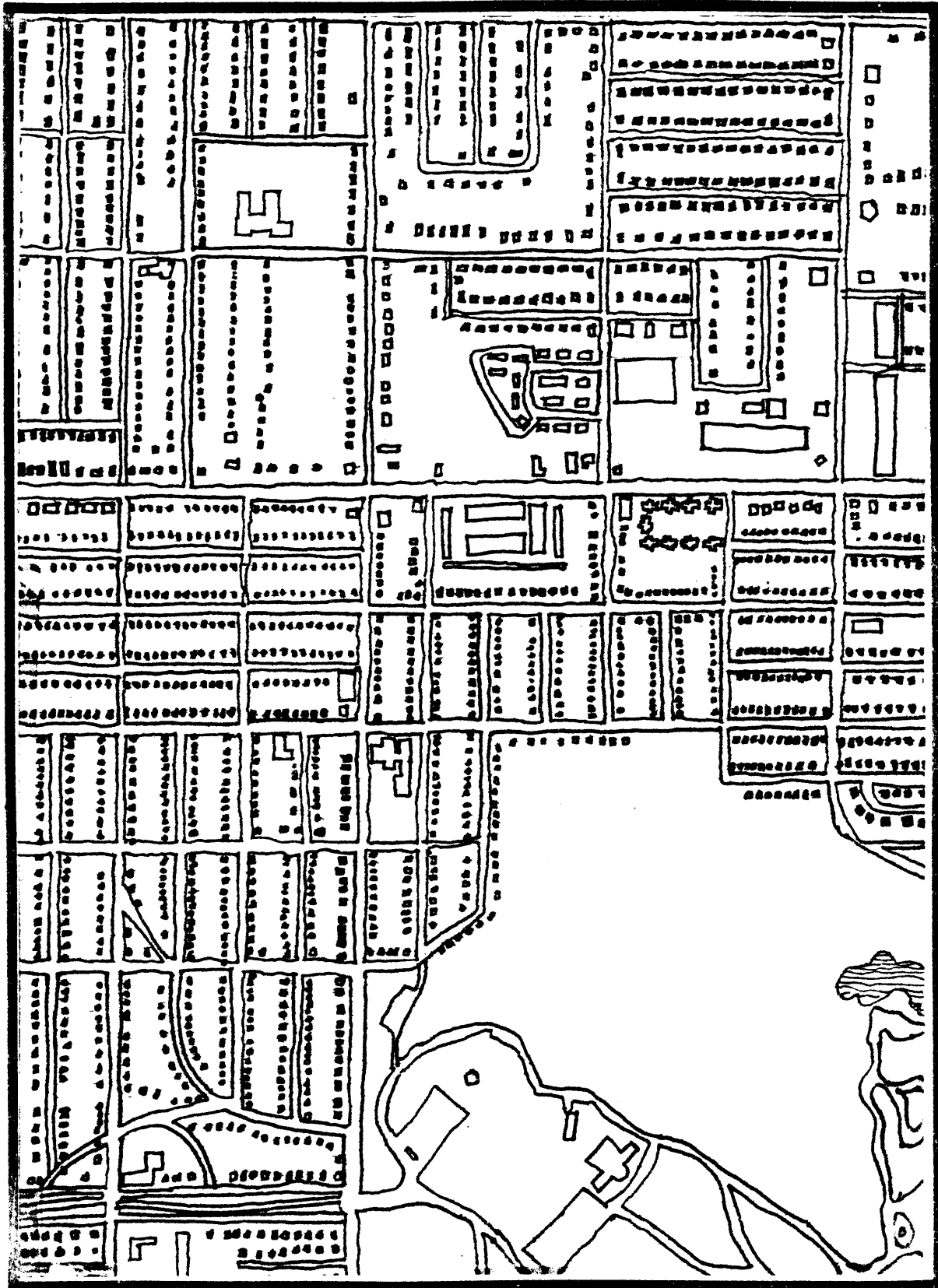

Figure 2-7

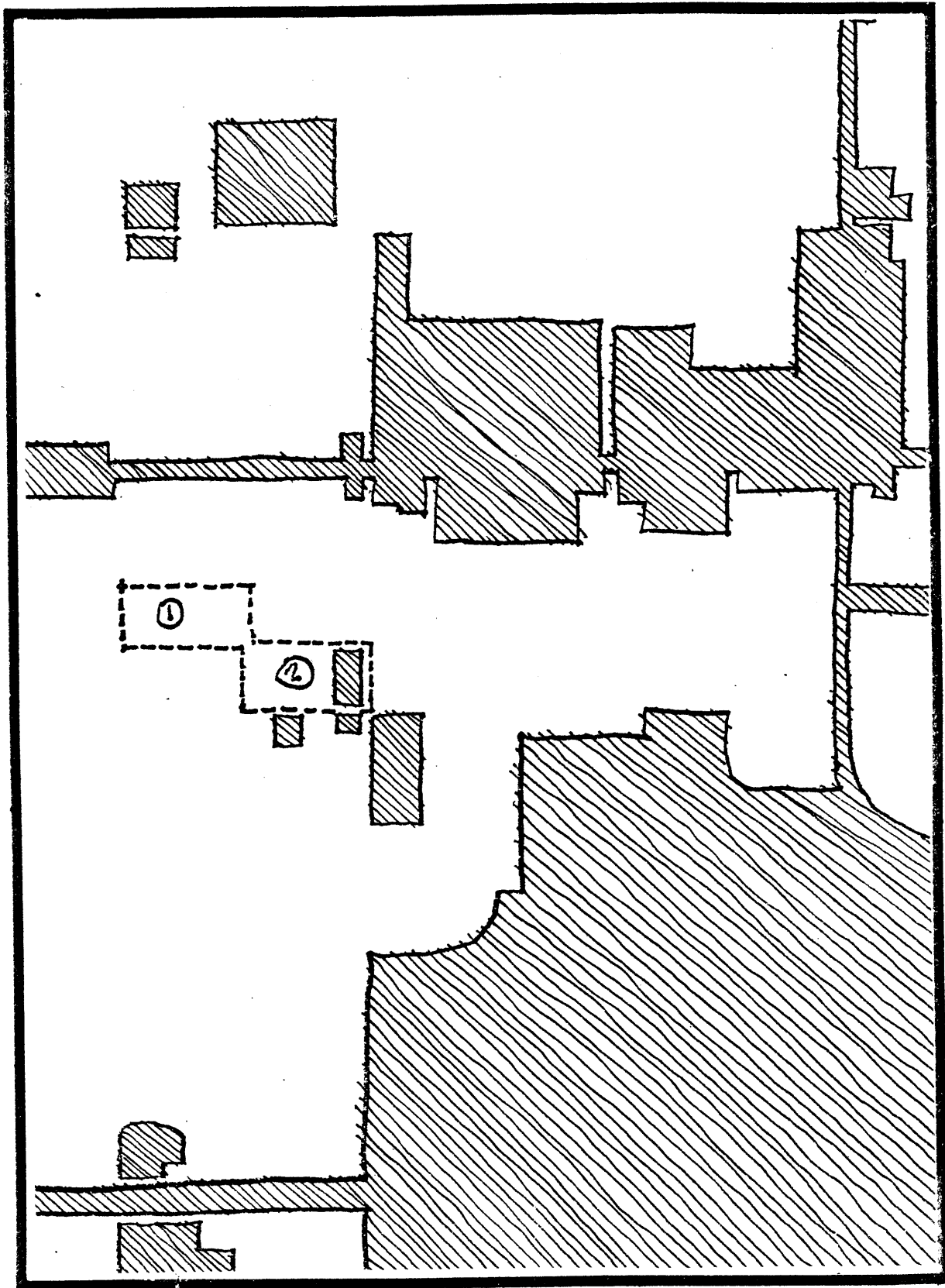

Figure 2-8

the higher density housing is located near the major thoroughfares. The patterns are universal, but unlike other cultures, they are not rigidly hierarchical. One might argue that such functional predictability is dull, but one must only be reminded that though morphologies remain constant, functions change, as schools become elderly housing apartments and churches become community centers. The greatest variety exists in the thematic single family houses, aligned neatly in a row, each with different, but systematically coherent, facades.

This similarity is based on the original subdivision regulations that existed before Falcon Heights was incorporated. It was further developed with the zoning regulations in Falcon Heights which govern R-1 built form. These regulations establish built/open space patterns with lot area, lot width, height, and yard requirements (see Figure 10A). We will look at this similarity further with a detailed examination of Block One in Figure 2-11.

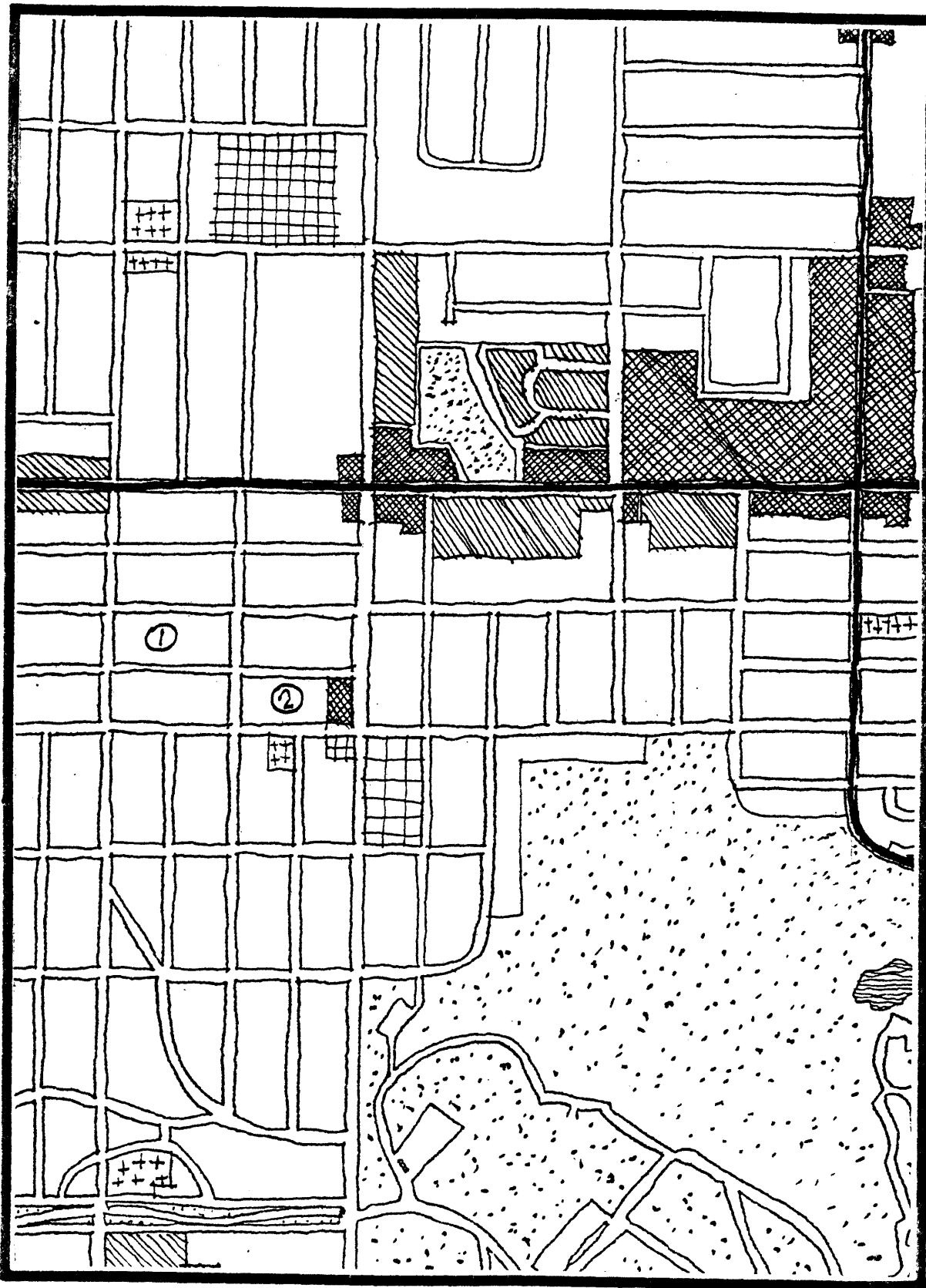

Figure 2-9

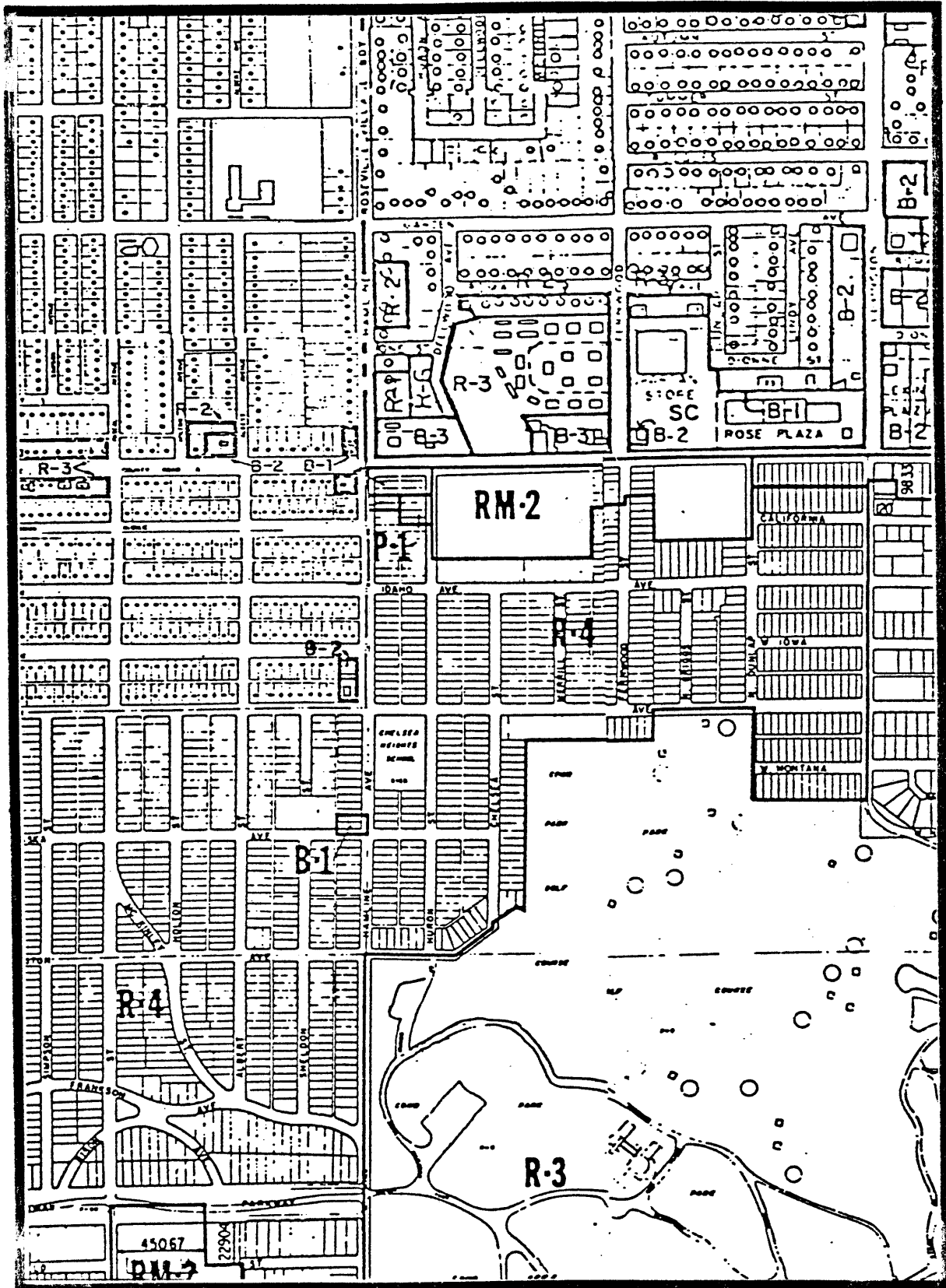
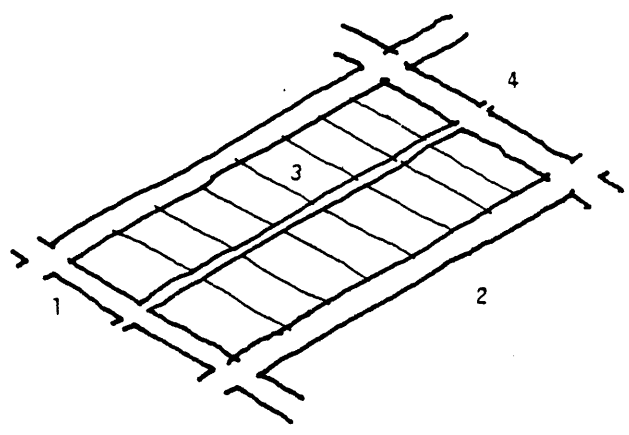

Figure 2-10

A. SUBDIVISION REGULATIONS

- 1. Street Easement
- 2. Block Size
- 3. Lot Subdivision
- 4. Alley Easement



B. DISTRICT ZONING CODE (RESIDENTIAL)

1. Lot Area $XY = 7,500$ SF

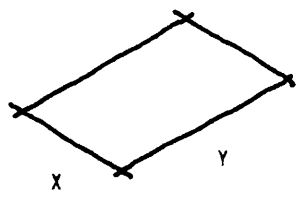

2. Lot Width $x = 50$ Feet

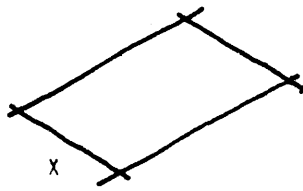

3. Yard Requirements

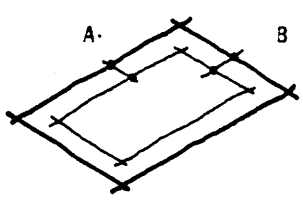

4. Bulk Requirements FAR 1.9

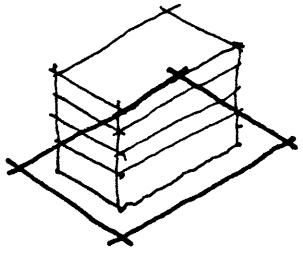

Figure 2-10A

Block One measures 600 feet by 268 feet and contains 12 lots, each zoned R1 and measuring approximately 50 x 125 feet (see Figures 2-11 and 2-12). The R1 zoning is for single family houses and governs the building heights, bulk, and set-back from the perimeter property lines (see Figures 2-13 and 2-14). These relationships are summarized in the abstract models in Figures 2-15 and 2-16 showing the built and open space patterns.

In this abstract model drawing (Figures 2-15 and 2-16), the thematic B and O zones are cross-hatched, while the OB margins are diagonally hatched and represent the margins between the built and unbuilt zones. The O3/O4 margin is the location of auxiliary buildings or garages adjacent to the alley in zone O4. The horizontal cross section drawings show the maximum permitted height of the buildings with the diagonally hatched OB margin. The heights of all the houses on the block fall within this margin. The vertical section at the left of the page which cuts across shows the typical house or variant. It is the section that we want to examine further in an enlarged form.

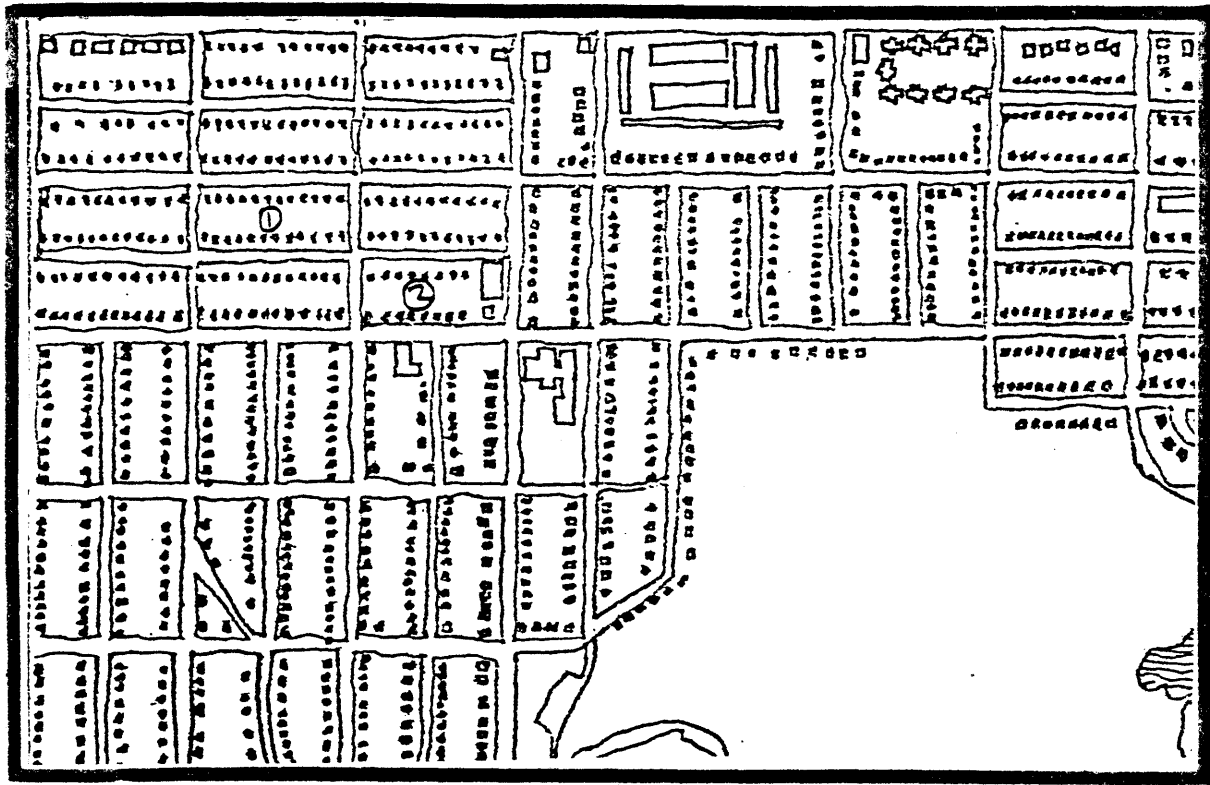

Figure 2-11

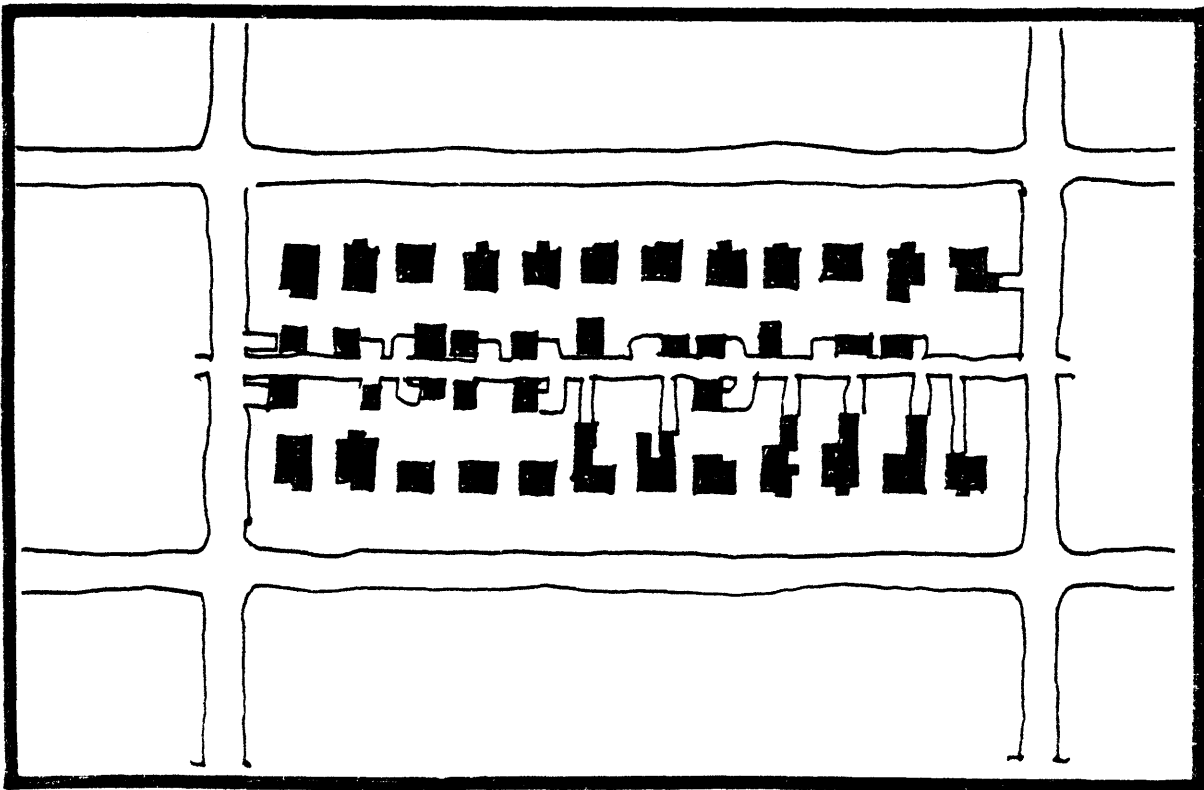

Figure 2-12

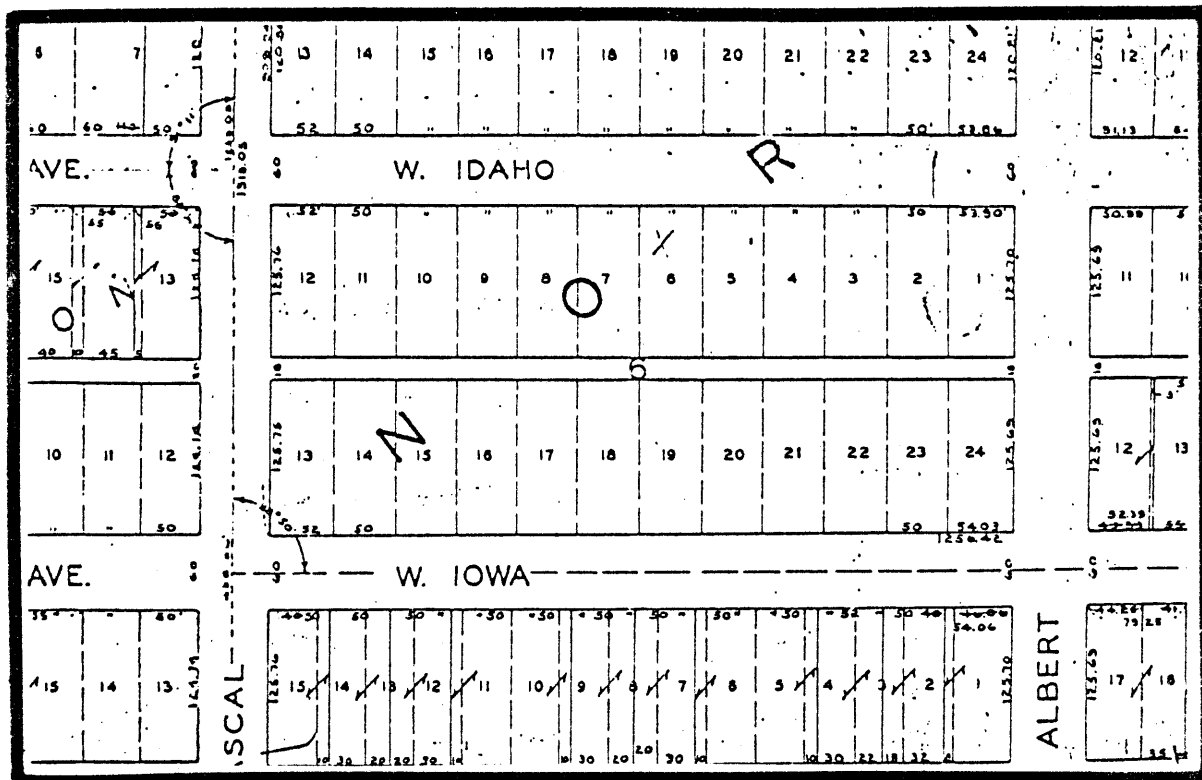

Figure 2-13

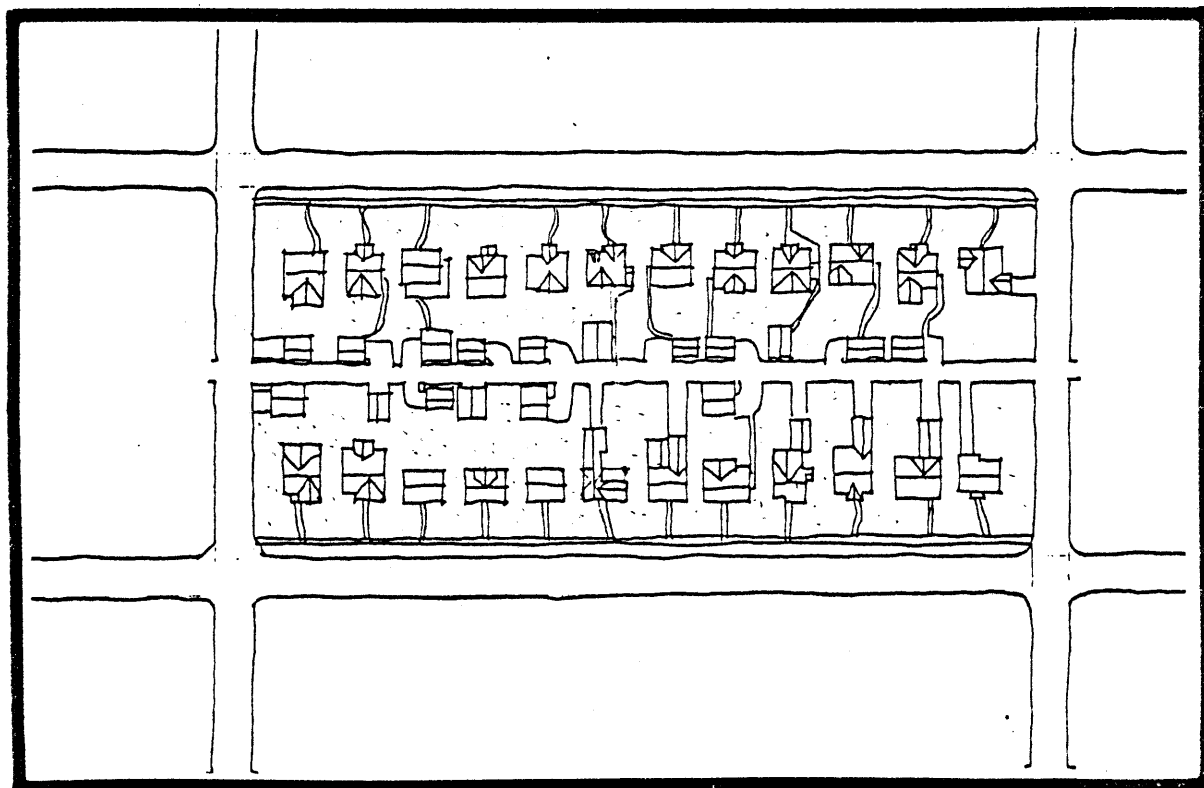

Figure 2-14

Figure 2-16

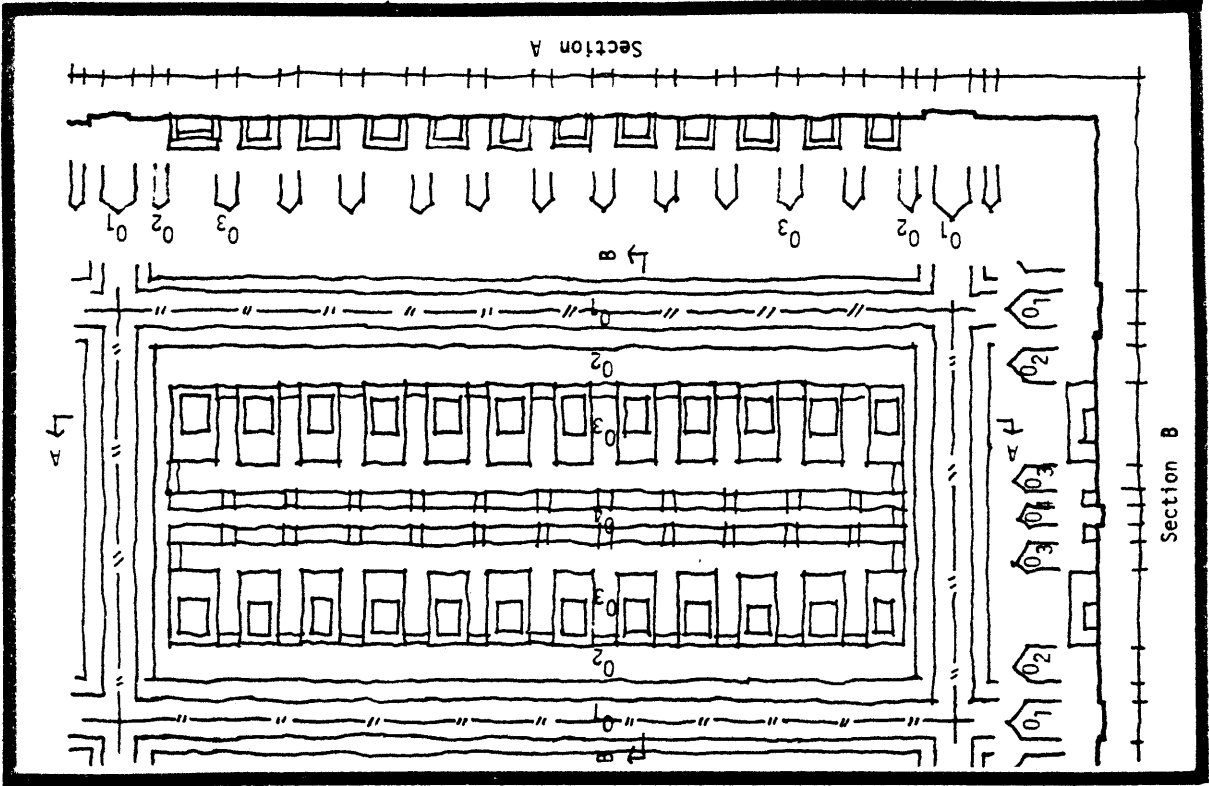
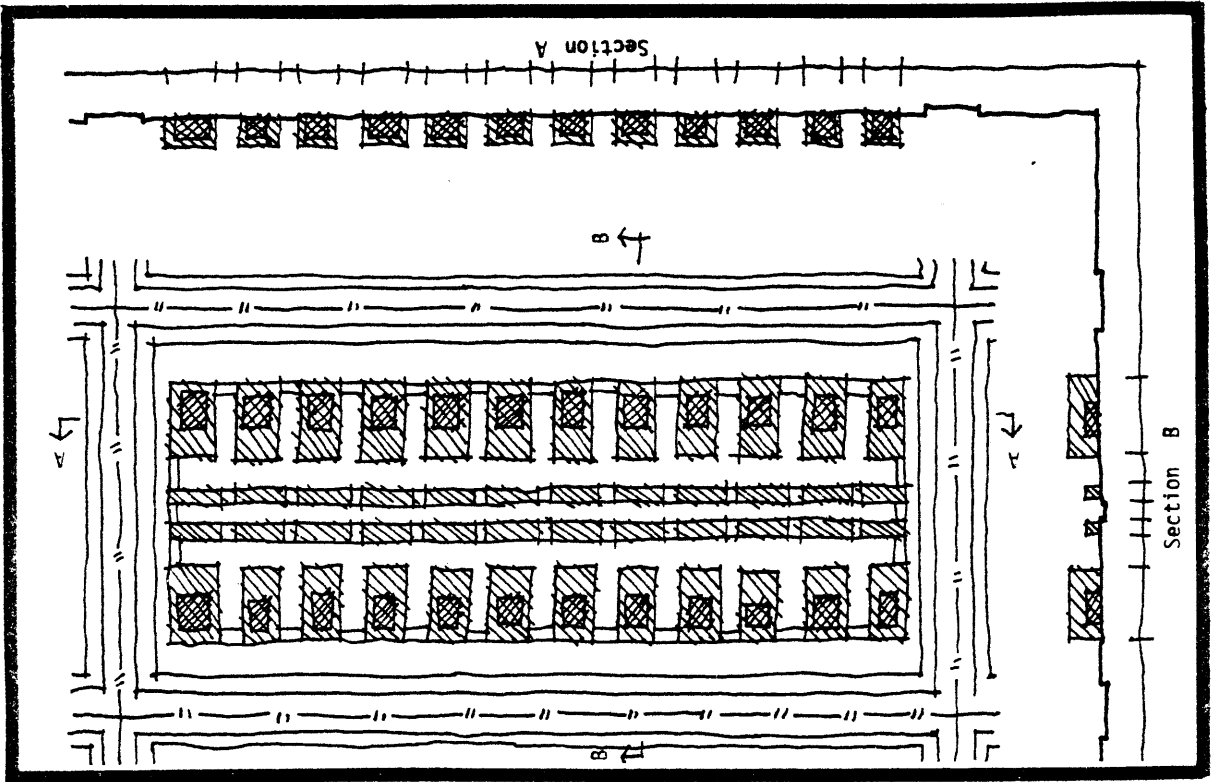

Figure 2-15



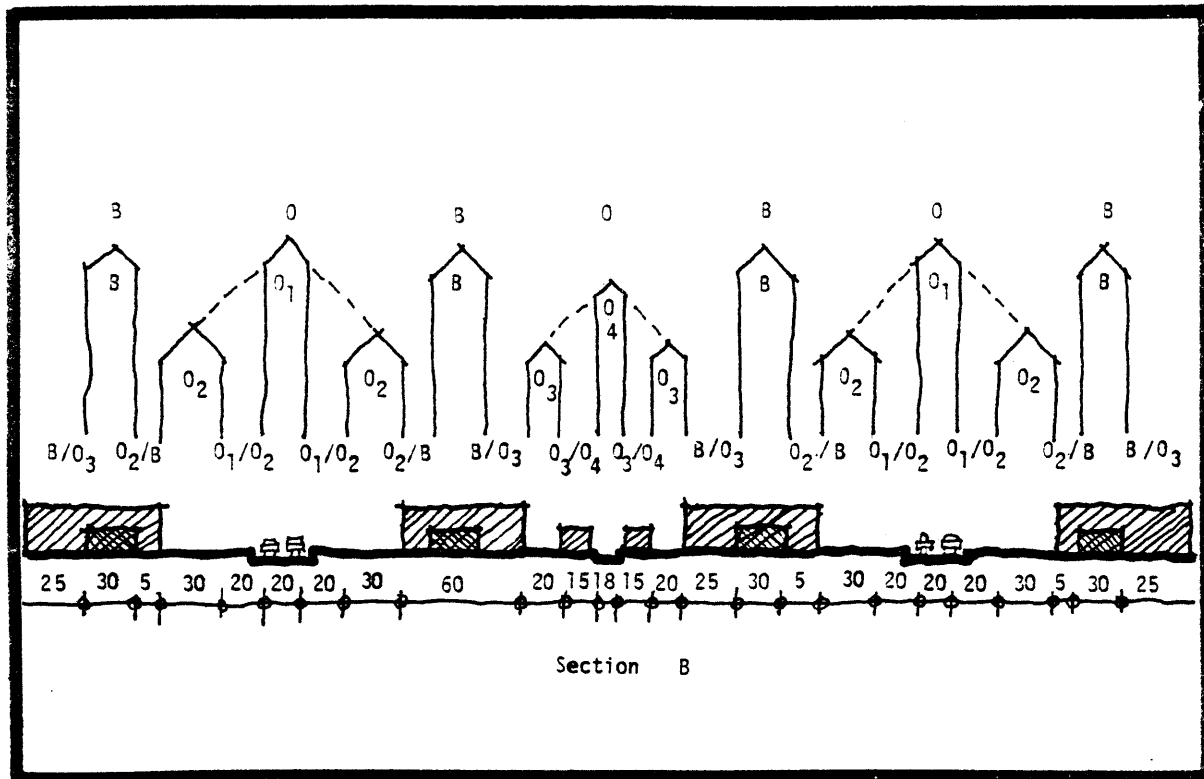

Figure 2-17

Here in this sectional sketch we see the enlarged zones (see Figure 2-17). The notations are defined by function as follows: The O1 zone is for public movement. The O1/O2 margin is the interface between public and private land. The O2 zone is privately owned front space. The O2/B margin is the most forward position of the built area as defined by setback requirements. The O3 zone is the rear and side open space. The O3/O4 margin is the transition zone between private and public property ending at the property line. Finally is the O4 zone, which is for semi-public movement. It is a convention that the zoning always parallels the major front street.

With these zoning patterns, the morphological description of the block is complete. The zoning/margin relationship describes built environment in an abstract, notational system which can be applied to a variety of cultural contexts. Casual observation shows that there is a progression from public to private from the O1 zone to the O3 zone. This pattern typifies residential settings in most cultures.

The dimensions of the zones are the result of the platting of the land for anticipated functional uses by the municipality and the land developers based on formal requirements outlined in the municipal subdivision and zoning ordinance regulations. Falcon Heights zoning ordinances for R-1 residential areas are shown in Figure 2-18. The zoning ordinances do not reflect the conditions we have studied, but instead reflect those for homes built after 1948, ten years after construction in our study area was completed.

The levels of planning activity are shown in Figure 2-18A. Here the municipality at Level 2 controls the zoning ordinances via the City Council and the Planning Commission. Typical developers are located at Level 5. However, there is a review by actors at Levels 3 and 4 at Planning Commission and Village Council meetings which allows informal approval of building activity at the district and neighborhood levels.

The morphology implicit in the subdivision dimensional standards based on prescriptive, performance, or pattern criteria can, via the SAR "zoning" method, be broken out and examined. It is important to note, too, that the functional uses of the zones are based on legal Level 2 agreements and informal agreements among the owner occupants of the neighborhood themselves. The following chart is an effort to

SECTION 6 "R-1" ONE FAMILY RESIDENTIAL DISTRICT

Section 6.1 Permitted Uses

Within any "R-1" One Family Use District, no structure or land shall be used except for one (1) or more of the following uses:

- 6.1 (1) One Family detached dwellings.
- 6.1 (2) Public parks and playgrounds.
- 6.1 (3) Public and parochial schools provided no buildings shall be located within fifty (50) feet of any lot line of an abutting lot in an "R" Use District. Any fence erected around a play area shall be not less than fifteen (15) feet from a street line when said fence would be across the street from an "R" District.
- 6.1 (4) Churches including those related structures located on the same site which are an integral part of the church proper, convents or homes for persons related to a religious function on the same site provided no more than ten (10) persons shall reside on the site and no building shall be located within thirty (30) feet of any lot line of an abutting lot in an "R" District.
- 6.1 (5) Municipal buildings and structures, excluding storage of maintenance equipment and trucks over 1½ tons, stockpiling of aggregate and open storage of material, but including fire fighting apparatus, provided these shall not be located within thirty (30) feet of any lot line of an abutting lot in an "R" District.
- 6.1 (6) Existing farming operations, provided that any new building in which farm animals are kept shall be a distance of one hundred (100) feet or more from any other lot in an "R" District.
- 6.1 (7) New farming operations not involving the construction of new buildings.

Section 6.2 Conditional Uses

Within any "R-1" One Family Use District, no structure or land shall be used for the following uses except by conditional use permit.

- 6.2 (1) Golf courses, country clubs, tennis clubs, public swimming pools serving more than one (1) family.
- 6.2 (2) Land Reclamation and mining as regulated in Section 4.10 and 4.11.
- 6.2 (3) Essential service structures, provided no building shall be located within fifty (50) feet from any lot line of an abutting lot in an "R" District. The architectural design of service structures should be compatible to the neighborhood in which they are to be located.
- 6.2 (4) Off-street parking. When the proposed site of the off-street parking abuts on a lot which is in a "B" District and is in the same ownership as the land in the "B" District and subject to those conditions set forth in Section 14.2, and such other conditions as found necessary by the council to carry out the intent of this ordinance. However, such off-street parking shall be permitted as a conditional use in any "R-1" One Family Use District for church parking purposes.
- 6.2 (5) Accessory structures other than private garages.
- 6.2 (6) New farming operations involving the construction of new buildings.
- 6.2 (7) Greenhouses and vegetable stands selling products grown on the premises.

Section 6.3 Permitted Accessory Uses

Within the "R-1" One Family District the following uses shall be permitted accessory uses:

- 6.3 (1) Private garages and parking space.
- 6.3 (2) Private swimming pool and tennis court.
- 6.3 (3) Home occupation.
- 6.3 (4) Signs as regulated in Section 14 of this Ordinance.
- 6.3 (5) Buildings temporarily located for purposes of constructing on the premises for a period not to exceed time normally necessary for such constructing.
- 6.3 (6) Gardening and other horticultural uses where no sale of products is conducted on the premises.
- 6.3 (7) Decorative landscape features.

Section 6.4 Lot Area, Height, Lot Width and Yard Requirements

- 6.4 (1) No structure or building shall exceed two (2) stories or twenty-five (25) feet in height, whichever is lesser in height, except as provided in Section 15 of this Ordinance.
- 6.4 (2) A side yard abutting a street shall not be less than thirty (30) feet in width.
- 6.4 (3) The following minimum requirements shall be observed subject to the additional requirements, exceptions and modifications as set forth in this Section and Section 15.

Height	Lot Area	Lot Width	Front Side Rear		
			Yard	Yard	Yard
1 story	10,000 sq. ft.	75' interior lot 90' corner lot	30'	5'	30'
2 stories	10,000 sq. ft.	75' interior lot 90' corner lot	30'	7½'	30'

Figure 2-18.

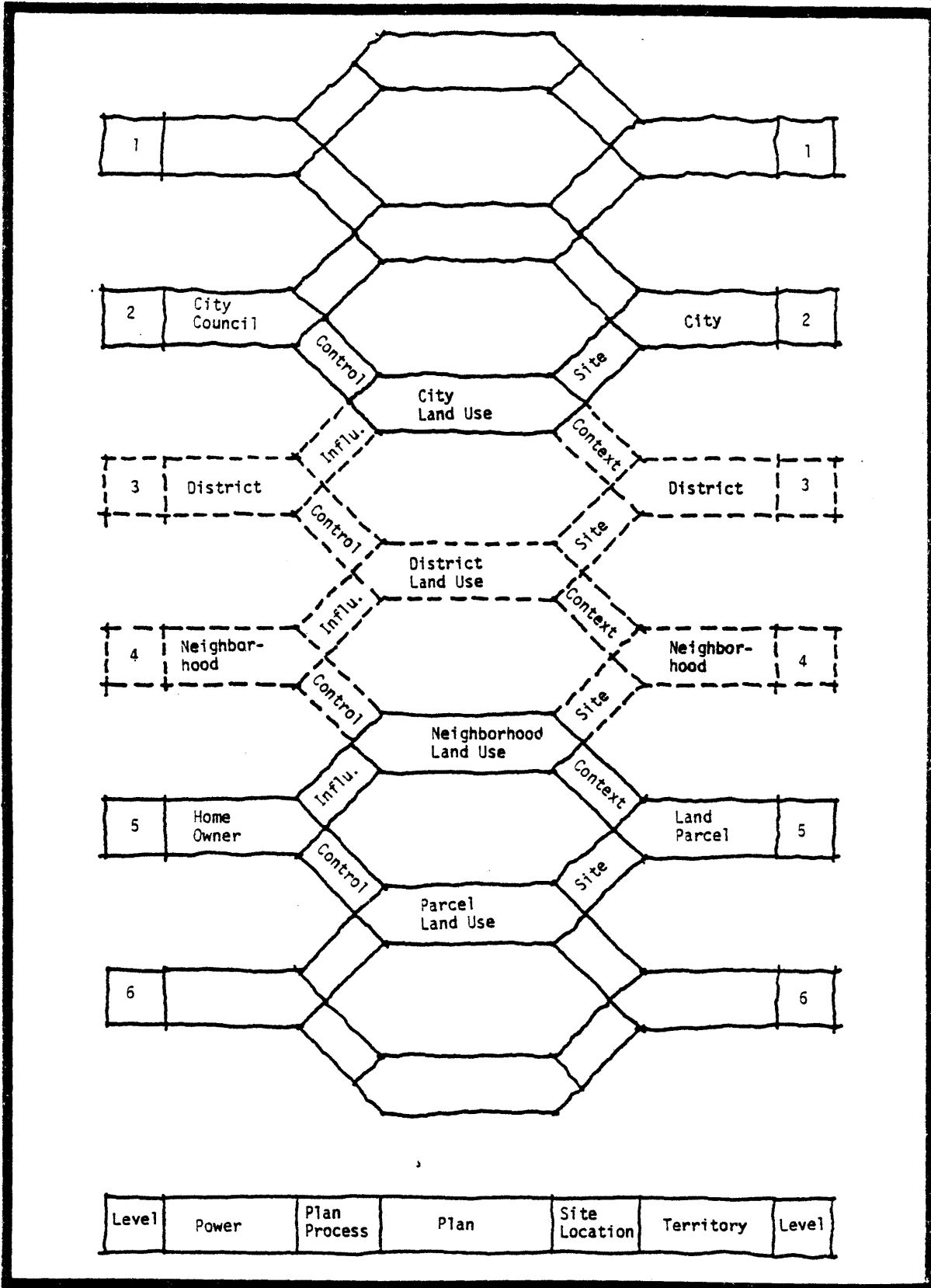

Figure 2-18A

break out and identify these standards.

<u>Zone/Margin</u>	<u>Dimensional Standard</u>	<u>Function</u>	<u>Requirement/Level</u>
01	20 feet	vehicle movement	formal (Level 2)
01/02	20 feet	car storage, pedestrian movement	formal (Level 2)
02	30 feet	symbolic	formal (Level 2)
02/B-02/03	4 feet	symbolic	informal (Level 5)
B	26 feet	shelter	formal (Level 5)
03/B	4-15 feet	private activity	informal (Level 5)
03	35 feet	private activity	informal (Level 5)
03/04	15 feet	storage for car and waste	formal (Level 2)
04	18 feet	semi-private movement	formal (Level 2)

So we see that functional activities within the morphology are the combination of formal, legal, municipal requirements at Level 2 and informal agreements among land parcel owners at Level 5 and the neighborhood, which are reflected in subdivision and zoning regulations and subsequently in the organization and use of built and open space. When one moves into such a district, he conforms to the collective symbolic and cultural associations that one ascribes to such a community by using the built and open space in the accepted way.

Let us shift to the vertical plane. If we look at the vertical section of the buildings parallel to the street, at the bottom of Figure 2-16, we see that among the B zone there is an O3 segment (combining side-yards) centered on the property line that determines, together with the B segment the rhythm of the street elevation. The ratio of the B/O3 segment and its continuity is a matter of the visual quality that one perceives while moving along the O1 zone (or street and the O1/O2 margin (sidewalk).

Looking at the O2/B margin in the front elevation of the typical house, one can see all the characteristics that define the vernacular quality of this neighborhood. Several typical examples are shown in Figure 2-19. We can focus on the details of the O2/B margin by applying an imaginary zoning pattern. Assume that the zones are centered on the windows which locate the horizontal center of the living space inside the house. The margin then is the transition between these living spaces in the floor below or the ceiling above depending on your perspective. Such zones and margins can be labeled as follows: L for lower living; 1 for first level living; 2 for second level living; and R for attic space/living (centered on the center 2/3 of the roof. The subsequent margins are as follows: L/1 at the first floor line; 1/2 at the second floor line; 2/R at the attic floor line and so on depending on the number of floor involved: and finally the R/S margin is the silhouette of the roof against the sky (S).

An endless number of design guidelines can be developed by laypeople from this zoning matrix to develop prescriptive standards on what is built. In the hands of strict preservationists, the guidelines generated could be extensive and probably disastrous. Minimal guidelines can be developed which describe the contour of the O2/B zone, its surfaces, and its colors, as shown in the following table. The measurements are taken from a house similar to house 3 in Figure 2-17, which is taken from the photo on Figure 2-1.

Zone/Margin	Form	Pattern	Material	Color
L	extension	steps	concrete	gray
L/1	extension	bay window	wood	white
1	extension	entry	wood	white
1	extension	bay window	wood	white
1/2	extension	entry	wood	white
1/2	extension	roof	asphalt	black
2	flat	wood	white
2/R	sloped 2/3	wood/asphalt	white,black

In examining other qualities, one can also measure proportions, texture, window types, construction details, and roof angles (usually quite consistent because of the common use of the carpenter's square and the roof angles it creates).

Now we can combine our analytical drawings. By rotating Figure 2-15 to the vertical axis and by attaching Figure 2-19 in a laid-back elevation adjacent to the O2/B margin, we can construct an open space or "pathway diagram" which gives a qualitative sense of the street's

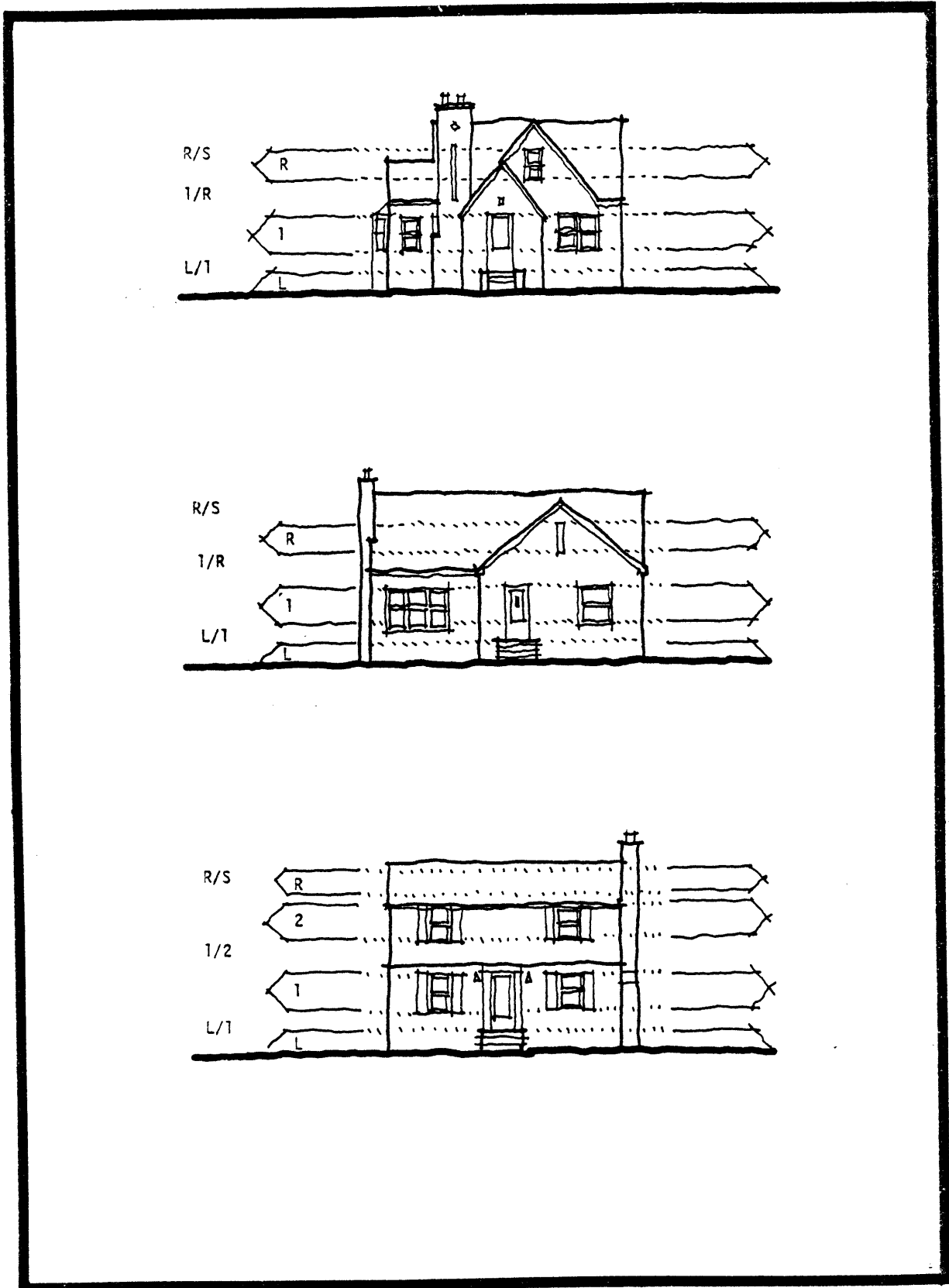

Figure 2-19

visual environment as seen by the public, which in turn can be quantified.

Typical pathway diagrams are shown in Figures 2-2, 2-21 and 2-22. Figure 2-20 is a pathway drawing that demonstrates regulatory requirements. It shows the dimensions of the building based on existing municipal zoning regulations governing building heights, setbacks, and side yards, which are defined for different functional uses. The drawing allows these characteristics to be seen in a collective context. Figure 2-21 concentrates on the "Materials" of the pathway. With a similar diagram many other characteristics could be described, such as form, color, details, symbols, transparency, rate of change, vegetation, and so on. Last of all is Figure 2-22, which shows the patterns that are common to the pathway. The repetition of these patterns creates the visual continuity of the street and are often ignored by architecturally designed interventions.

Among these three diagrams the perceptual, regulatory, and structural issues can be analyzed for similarity and diversity. The purpose is, of course, to identify those qualities that should be retained and encouraged in the guidelines for the district restoration and redevelopment. Also the diagrams can be compared among different neighborhood pathways. The key point is that the documents are observer oriented and easy to understand by laypeople. In fact, they are derived from drawings made by young children in describing their house and neighborhood (see Figure 22A and 22B).

One notes in reviewing this information that the strongest districts often create predictability by having symmetrical pathways.

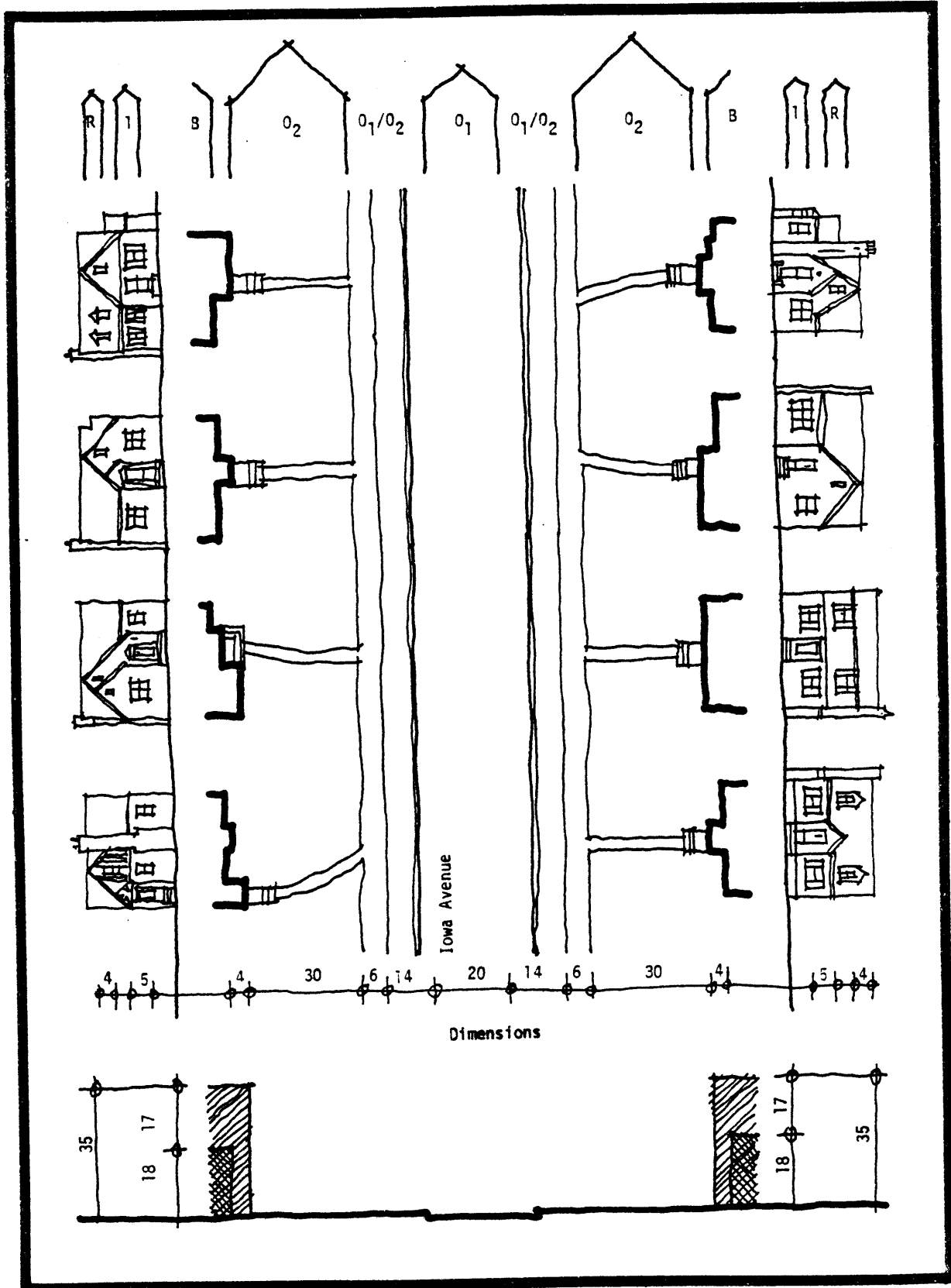

Figure 2-20

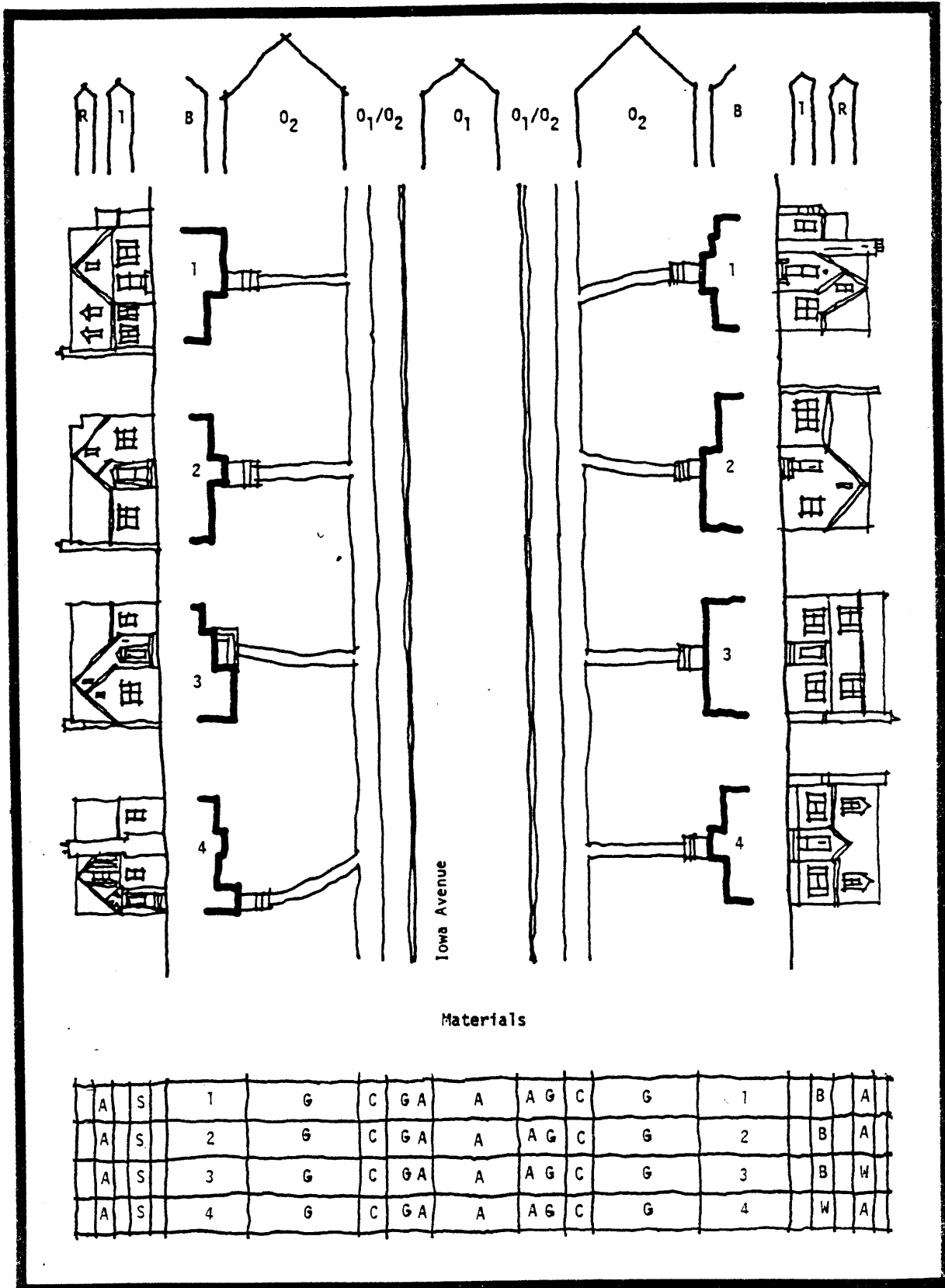

Figure 2-21

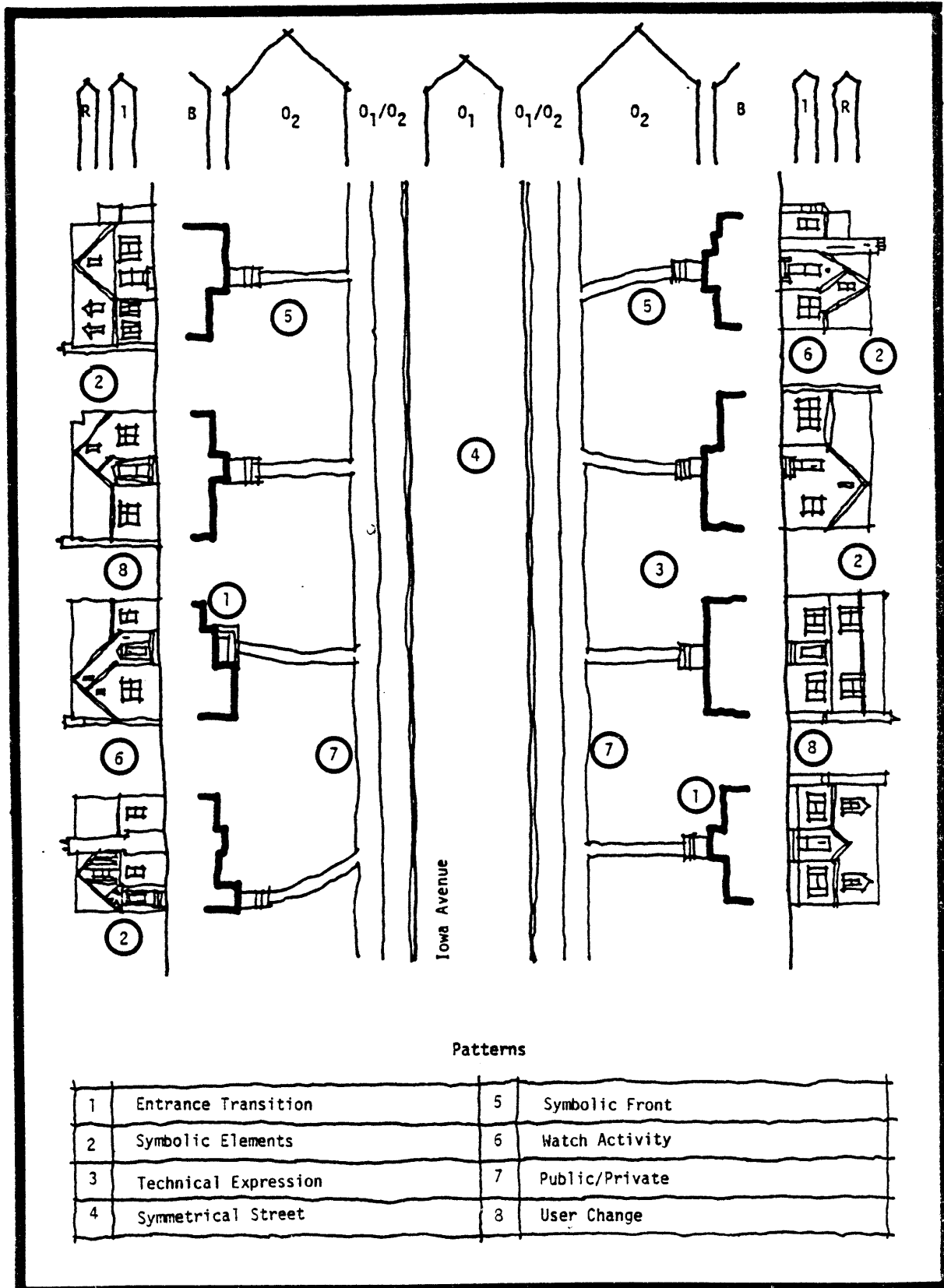

Figure 2-22



Figure 2-22A

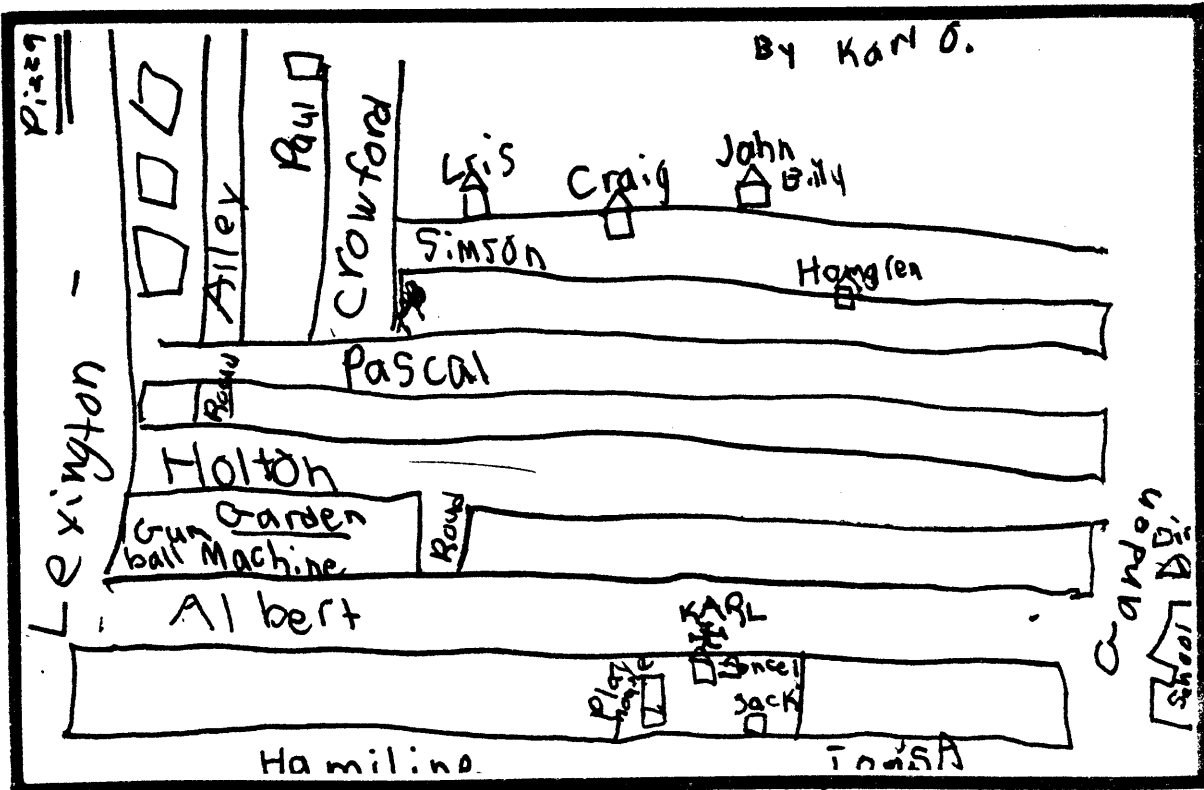

Figure 2-22B

Notice that structure and continuity are given by the similarity of the 01 and 02 zones as well as the 01/02 margin. Diversity is created by the different houses or variants which differ in a very systematic way, but yet also create a subtle continuity. Qualities of this pathway are universal and timeless and could be recognized by people of all cultures. They are qualities that can be seen on the boulevards of Paris or the residential streets of Kyoto.

One might ask why these characteristics are maintained despite the obvious change that has gone on during some 40 years of the district's existence. Why has consistency occurred with change? There are a number of reasons. The most obvious is the influence of municipal zoning regulations which govern the morphological and functional continuity of the district. Others are more subtle. First, each home is privately owned; consequently physical change (remodeling, additions, painting) occurs at different times with different rhythms, depending on the needs of the owner.

In fact, the district is never finished since this form of change is constantly going on. Yet the changes follow consistent rules which are based on the informal agreements (values) of each individual owner-occupant. Second, the houses were all built within ten years of each other with similar construction techniques. Third, the materials of repair are similar to the original, so that the additions and minor alterations carry the same character. Even when technological improvements in materials occur, they model the older forms, i.e. the wooden siding is replaced by aluminum or vinyl siding of the same texture and dimension and in acceptable color ranges.

Form is retained, and the material is improved. The reason for this consistency is that the homes are privately owned. The maintenance of neighborhood consistency is closely tied to maintaining property values and hence the investment of each individual home owner.

Here it is important to make a distinction between a vernacular system of building and an architectural system. In a vernacular system, the rules of what is appropriate are determined among those who control each home. In the architectural system, on the other hand, the architects determine what is appropriate for each building situation. In the latter case the owner or controller of the building cedes his power of choice to the expert, the architect, who determines what is formally appropriate or not. Once the architect is given this freedom, he usually tries to express uniqueness in his interventions by the use of a particular architectural formula for a given building, usually in contrast with its context. In other cases when the owner retains control over the architect, more traditional forms occur. This is why the new A.T. and T. building in New York City is designed as a grandfather clock, and many neighborhood branch banks resemble colonial Williamsburg, the epitome of American colonial tradition.

So we see that vernacular environments, where change is controlled by the owner, exterior consistency is maintained through self-imposed rules, again in an effort to maintain property values. In Falcon Heights, therefore, people don't plant vegetables in their O2 zone, nor do they paint their 1,2 zones and 1/2, 2/R margins with zebra stripes, although exceptions to this rule might be found.

In a simple way, then, we have described the thematic 01 and 02 zones and the 01/02 margin in this unattached Block City district in terms of the built and open spaces that we saw in Figure 2-1. It is the symmetry of the open space patterns and the differentiation of each built variant within vernacular rules that determine the physical quality of the district. It is a setting of theme and variation.

Yet without difference, large thematic areas would become dull and monotonous. Hence, non-thematic areas are desirable for contrast, and we now turn to a non-thematic area. Commonly, non-thematic areas in a residential setting are commercial, institutional land uses, which by their functional requirements have a different morphology. We will look at a non-thematic commercial area within the residential district.

If we examine the east or right side of Block Two, we see non-thematic built and spatial elements (see Figure 2-11). One can see that the west or left side of this block resembles the built space we have examined in Block One, so it is unnecessary to describe it. We map Block Two on the east end in the same fashion that we map Block One, even though we are describing non-thematic elements (see Figures 2-25 and 2-26). Note that even though the same patterns apply, the dimensions of the 02 zone have changed and the 03 zone has disappeared entirely with only the B/04 margin remaining (see Figures 2-27 and 2-28). This morphological difference as expressed in the different zoning requirements explains the non-thematic characteristics (see Figure 2-29).

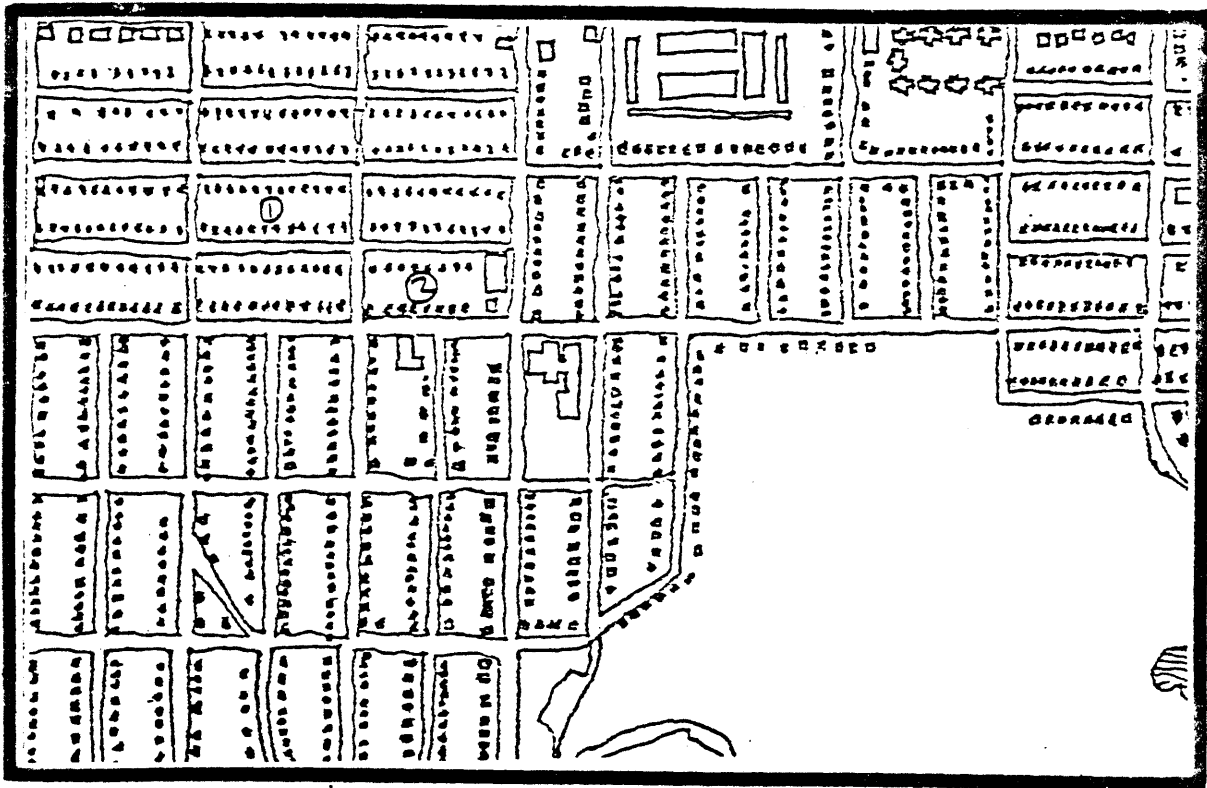

Figure 2-23

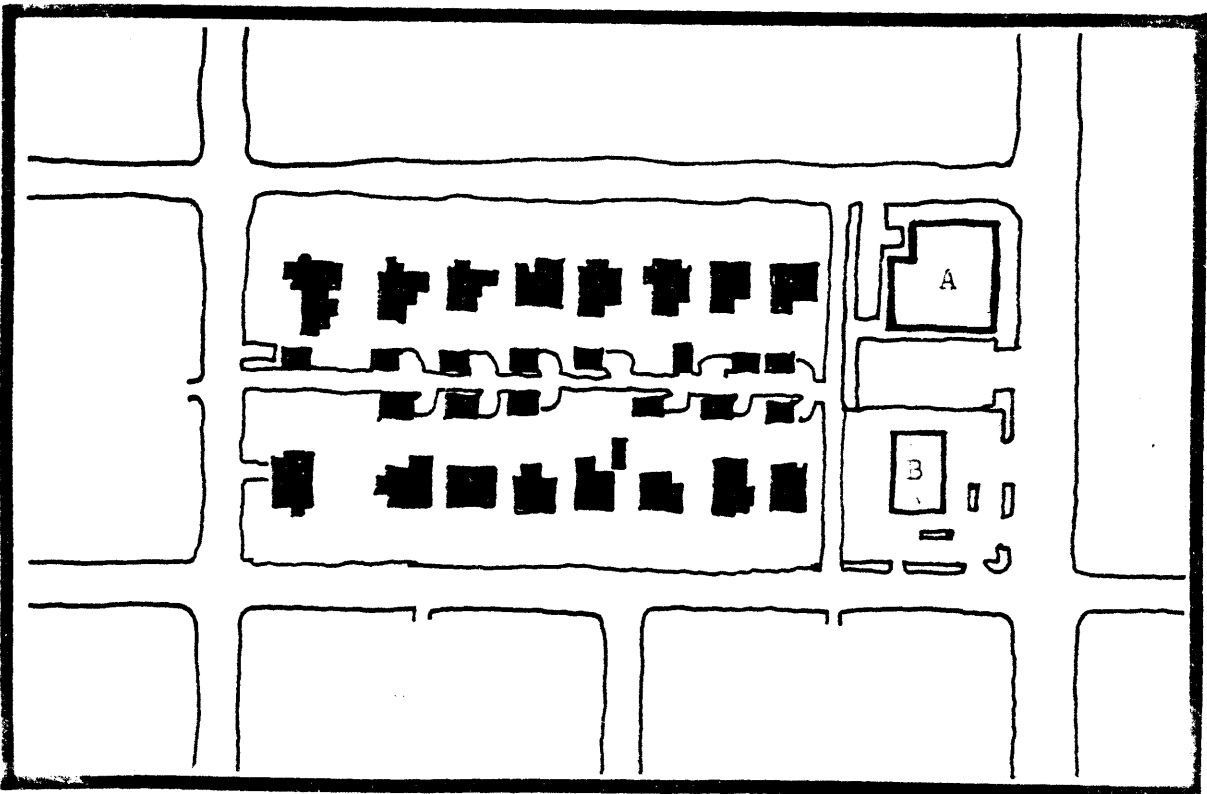

Figure 2-24

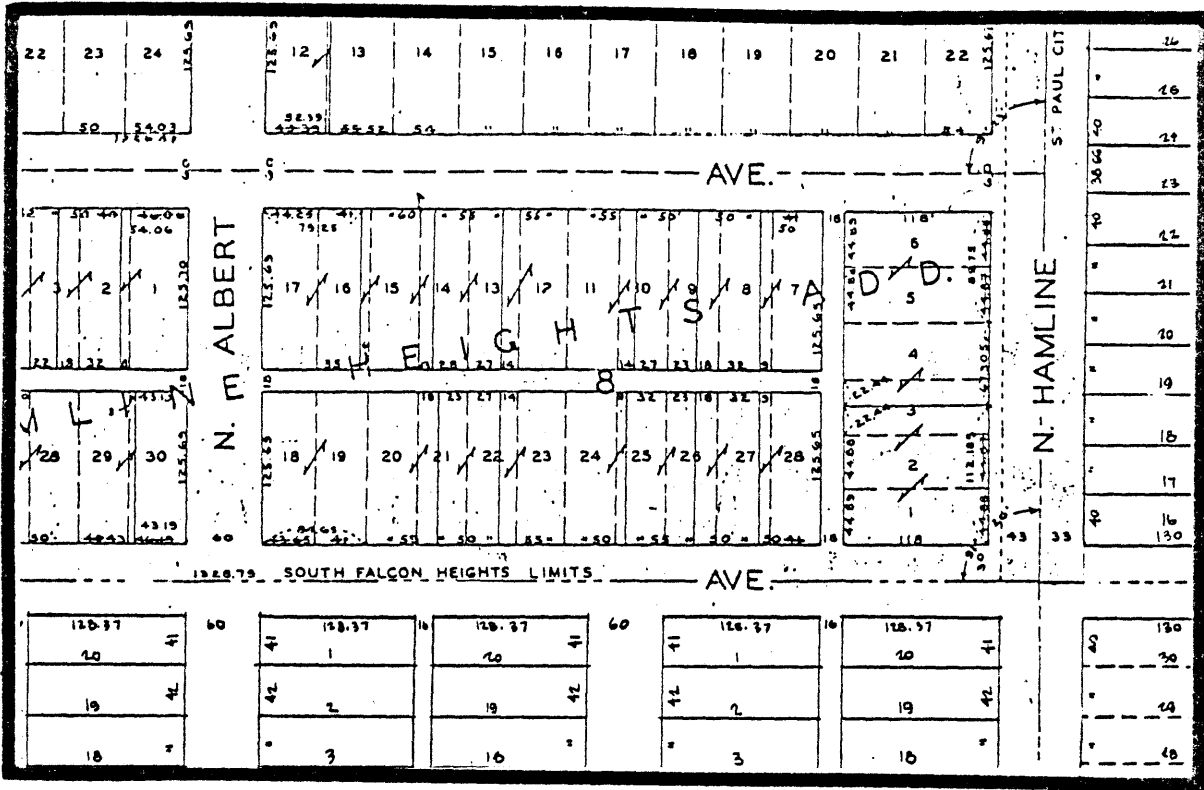

Figure 2-25

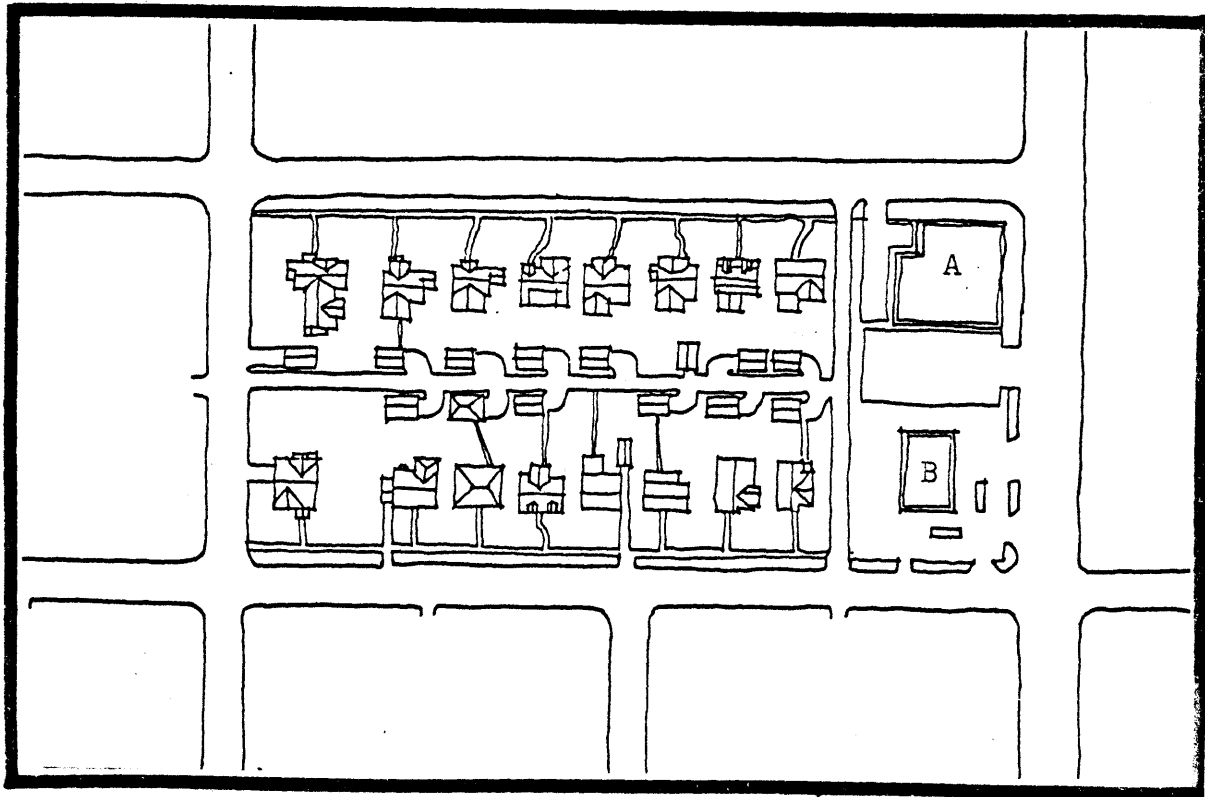

Figure 2-26

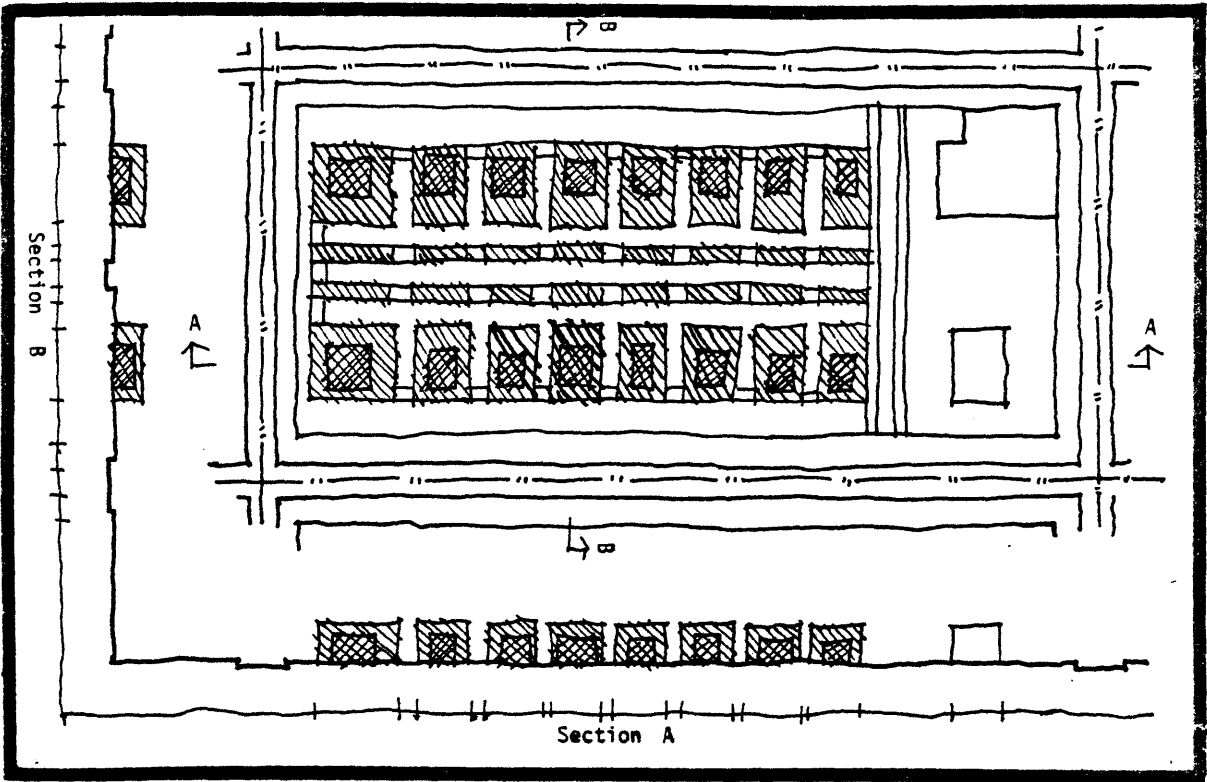

Figure 2-27

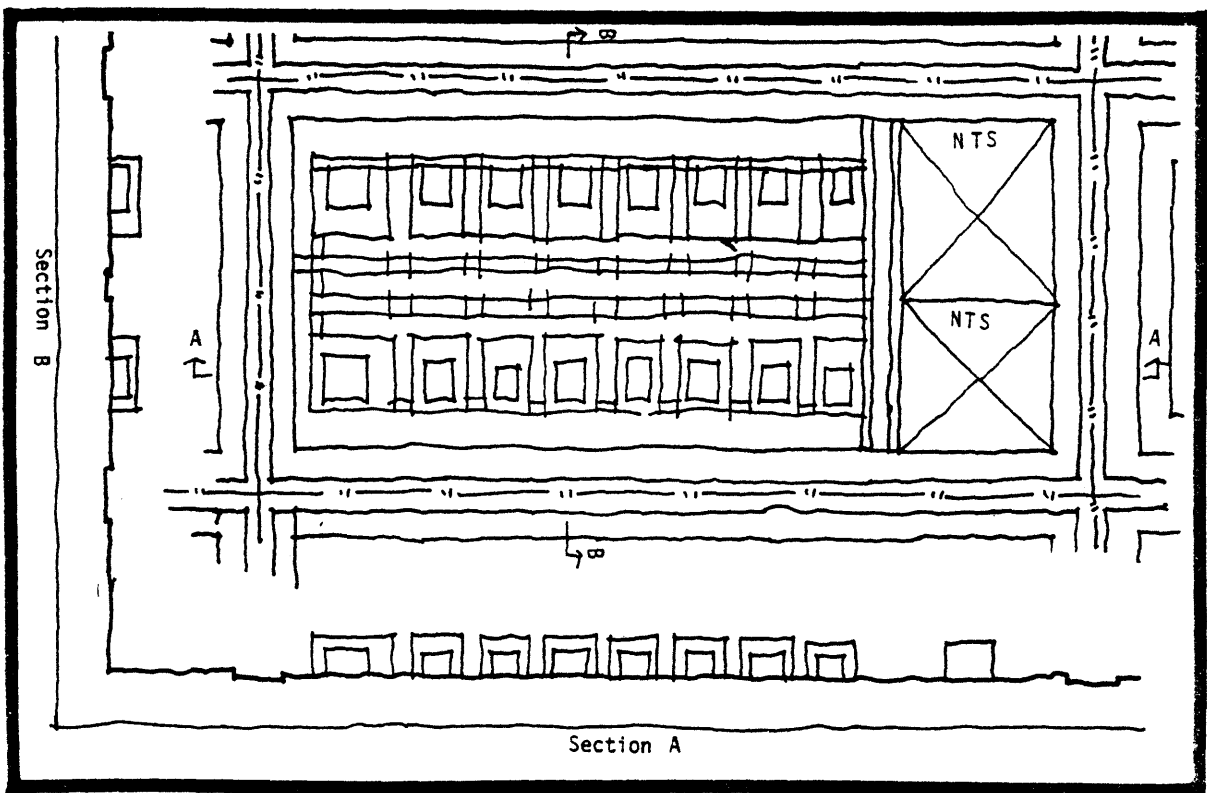

Figure 2-28

SECTION 11 "B-2" RETAIL BUSINESS DISTRICT

Section 11.1 Permitted Uses

Within any "B-2" Retail Business District, no structure or land shall be used except for one (1) or more of the following uses.

- 11.1 (1) Antique or gift shop.
- 11.1 (2) Appliance store.
- 11.1 (3) Art and school supply store.
- 11.1 (4) Auto accessory store.
- 11.1 (5) Bakery goods sales, and baking of goods for retail sales on premises.
- 11.1 (6) Barber Shop.
- 11.1 (7) Beauty Shop.
- 11.1 (8) Bicycle sales and repair.
- 11.1 (9) Book, office supply and stationery store.
- 11.1 (10) Candy, ice cream and popcorn, nuts, frozen dessert and soft drink shop, but not of the drive-in type.
- 11.1 (11) Camera and photographic supply store.
- 11.1 (12) Delicatessen
- 11.1 (13) Drug store.
- 11.1 (14) Dry cleaning and laundry pick-up stations including incidental pressing and repair.
- 11.1 (15) Dry goods store.
- 11.1 (16) Furniture store, rugs and floor covering sales.
- 11.1 (17) Gift or novelty store.
- 11.1 (18) Grocery, fruit or vegetable store.
- 11.1 (19) Hardware store.
- 11.1 (20) Hobby store including handicraft classes not to exceed ten (10) persons.
- 11.1 (21) Jewelry sales and repair store.
- 11.1 (22) Laundromat of the self-service type.
- 11.1 (23) Library.
- 11.1 (24) Meat market, but not including processing for a locker.
- 11.1 (25) News stand.
- 11.1 (26) Offices.
- 11.1 (27) Paint, wallpaper sales.
- 11.1 (28) Photographic studio.
- 11.1 (29) Pipe and tobacco shop.
- 11.1 (30) Record shop.
- 11.1 (31) Restaurant, cafe, tea room, tavern.
- 11.1 (32) Shoe sales and repair.
- 11.1 (33) Small appliances repair shop.
- 11.1 (34) Sporting goods stores.
- 11.1 (35) Variety store.
- 11.1 (36) Wearing apparel shop.

Other retail uses of a similar nature may be added to the above list of permitted uses upon request to the Council.

Section 11.2 Conditional Uses

Within an "B-2" Retail Business District, no structure or land shall be used for the following uses except by conditional use permit.

- 11.2 (1) Motor fuel stations subject to the performance standards as specified in Section 14.3 of this Ordinance.
- 11.2 (2) Drive-in establishments subject to the performance standards as specified in Section 14.4 of this Ordinance.
- 11.2 (3) Those uses permitted in Section 10.1.
- 11.2 (4) Accessory structures other than private garage.
- 11.2 (5) Advertising signs.
- 11.2 (6) Auto repair and used car sales.
- 11.2 (7) Boat and marine sales when conducted entirely within a building.
- 11.2 (8) Building material yards, provided it is conducted entirely within an enclosed structure.
- 11.2 (9) Business or trade school when conducted entirely within a building.
- 11.2 (10) Car wash establishments.
- 11.2 (11) Commercial greenhouse provided all outside storage is fenced in such a manner so as to screen the stored material from view when observed from the public street.
- 11.2 (12) Diaper or hand laundry service, dry cleaning plant, provided not more than ten (10) persons are employed.
- 11.2 (13) Electrical service, heating, plumbing, appliance or air conditioning service shop, provided they do not employ more than six (6) persons in repair or processing.

11.2 (14) Garden supply store provided it is conducted entirely within an enclosed structure.

11.2 (15) Motels, motor hotels and hotels, provided the site shall contain not less than six hundred (600) square feet of lot area per unit.

11.2 (16) Newspaper and publishing office.

11.2 (17) Optical and jewelry manufacturing.

11.2 (18) Pet shop provided the operation shall not include the boarding of pets on the site, the maintaining of pens or cages outside of the building or the operating so as to cause an offensive odor or noise.

11.2 (19) Photographic supplies and processing of film and prints.

11.2 (20) Printing shop.

11.2 (21) Picture framing.

11.2 (22) Radio and Television repair.

11.2 (23) Seat cover upholstery or drapery shop.

11.2 (24) Television and radio stations and transmitting towers.

11.2 (25) Wholesale distribution, wholesale office and show rooms.

11.2 (26) Armories, convention halls, sports arenas and stadiums, bowling gymnasiums, Y.M.C.A., Y.W.C.A., night clubs.

Section 11.3 Permitted Accessory Uses

Within any "B-2" District the following shall be permitted accessory uses.

- 11.3 (1) Any use permitted in Section 9.3 and as regulated therein.

Section 11.4 Height, and Yard Requirements

11.4 (1) No structure or building shall exceed three (3) stories or thirty-five (35) feet in height whichever is the greater except as provided for in Section 15.

11.4 (2) A side yard abutting on a street shall not be less than thirty (30) feet and when abutting a lot in an "R" District shall not be less than forty (40) feet. However, no side yard shall be required when adjacent to a party wall, subject to the regulations of Section 15.3.

11.4 (3) Rear yard requirements may be reduced to ten (10) feet at alley lines.

11.4 (4) The following minimum requirements shall be observed subject to additional requirements, exceptions and modifications as set forth in this Section and Section 15.

Front Yard	Side Yard	Rear Yard
30'	10'	20'

Section 14.3 Motor Fuel Stations

Motor fuel stations in all districts shall be subject to the following performance standards:

14.3(1) A fence or wall of acceptable design not over six (6) feet in height or less than three (3) feet shall be constructed along the property line when said use abuts property residentially used or in an "R" District, and said fence shall be adequately maintained. Application of this provision shall not require a fence within the required front yard.

14.3(2) The entire site other than that taken up by a structure or planting shall be surfaced with a material to control dust and drainage.

14.3(3) A drainage system subject to approval of the Village Engineer shall be installed.

14.3(4) A box curb not less than six (6) inches above grade shall separate the public right-of-way from the motor vehicle service areas, except at approved entrances and exits.

14.3(5) The lighting shall be accomplished in such a way as to have no direct source of light visible from the public right-of-way or adjacent land in residential use.

14.3(6) Pump islands shall be installed and conform to yard requirements.

14.3(7) No driveway at a property line shall be less than twenty (20) feet from the intersection of two street right-of-way lines.

14.3(8) Each motor fuel station may have one (1) pedestal-type sign not in excess of sixty-four (64) square feet nor more than twenty-five (25) feet in height, erected within the front yard and no part of the sign shall be less than six (6) feet from a property line measured as a horizontal distance.

The pedestal shall not be greater than eighteen (18) inches in diameter and no part of the sign surface shall be less than twelve (12) feet vertical distance from the grade of the nearest driveway or parking area. The pedestal shall not be less than five (5) feet from a driveway.

Figure 2-29

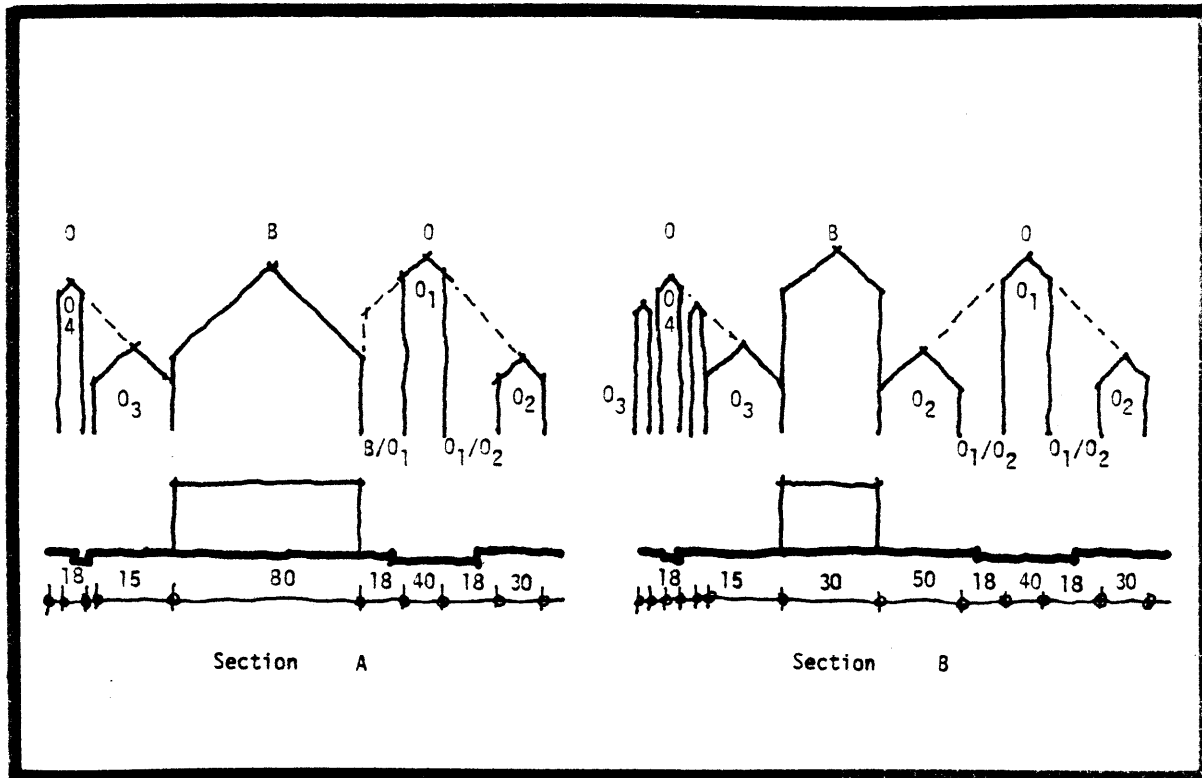

Figure 2-30

By comparing the two non-thematic examples in sectional form, we see the vast differences in the O₂ zones (setback) which account for the disruption of the neighborhood's sense of open space corridor, a prominent quality in this district. However, from a functional sense, the non-thematic, wider O₂ zone in the variant "B" is totally appropriate for its function, providing space for pumping gas into waiting cars (see Figure 2-30).

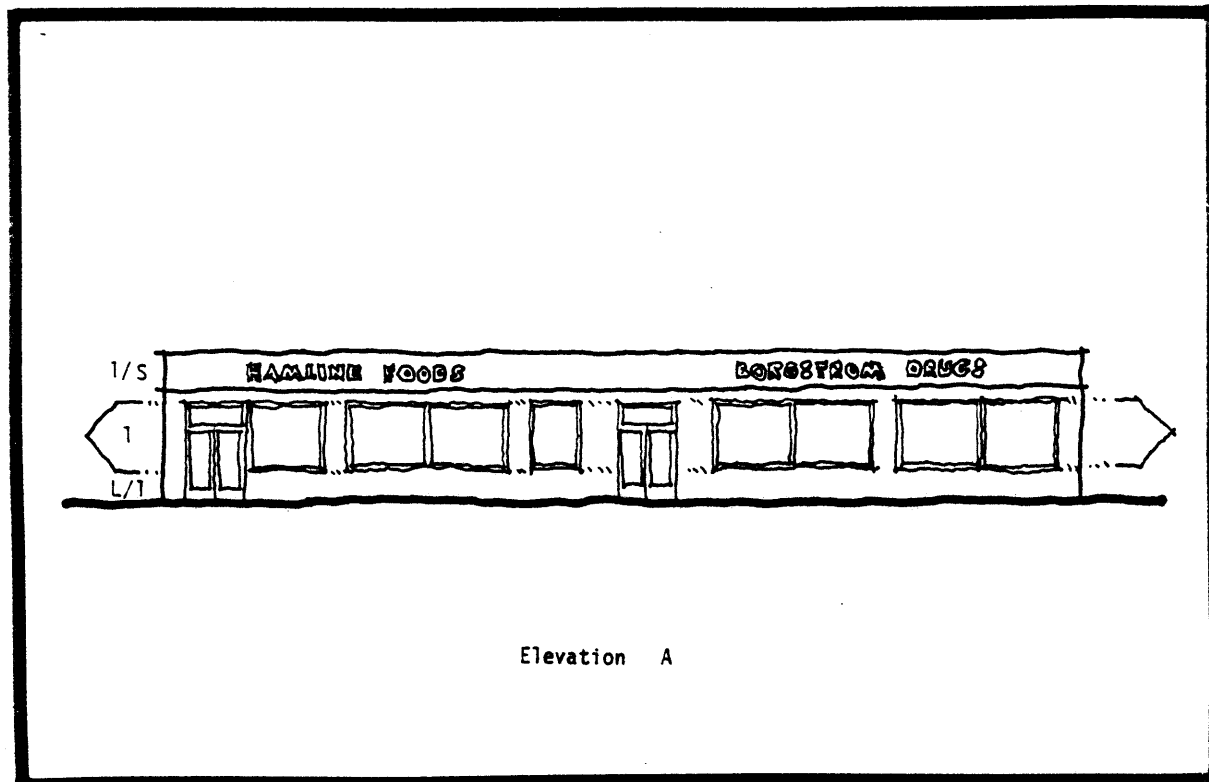

Figure 2-31

The same procedure can be used in examining the elevations of the non-thematic structures. If we look at the elevation of the northeast non-thematic built space, we see that the vertical zoning principle still applies in analyzing the front facade. In this case the L zone and the L/1 margin and the 1 zone are the same as the thematic facade elevation on the residential houses. A slight difference exists in the 1/S margin, which is equivalent to the R/S margin. It is the silhouetted area against the sky and the area used for signage.

Similarly the same open space pathway drawings can be made to

examine non-thematic built and open space in the built environment. Examination immediately shows the loss of symmetry in the open space corridor.

This is due to district patterns created by zoning law which place commercial functions on residential street corners and along large, non-thematic arterial roads (see Figure 2-9 and 2-10).

Figure 2-31 shows the different use of materials. As we said before, the other qualities could also be measured by the pathway diagram. Drawing 2-33 shows the difference in non-thematic built and open space and thematic built space due to the municipal zoning regulations which are different for commercial and residential functions. Patterns are examined in Figure 2-34. Here we see the obvious result in single use zoning regulation. Segregated uses result in radically different built and open space configurations. Here, the loss of open space continuity is quite strong.

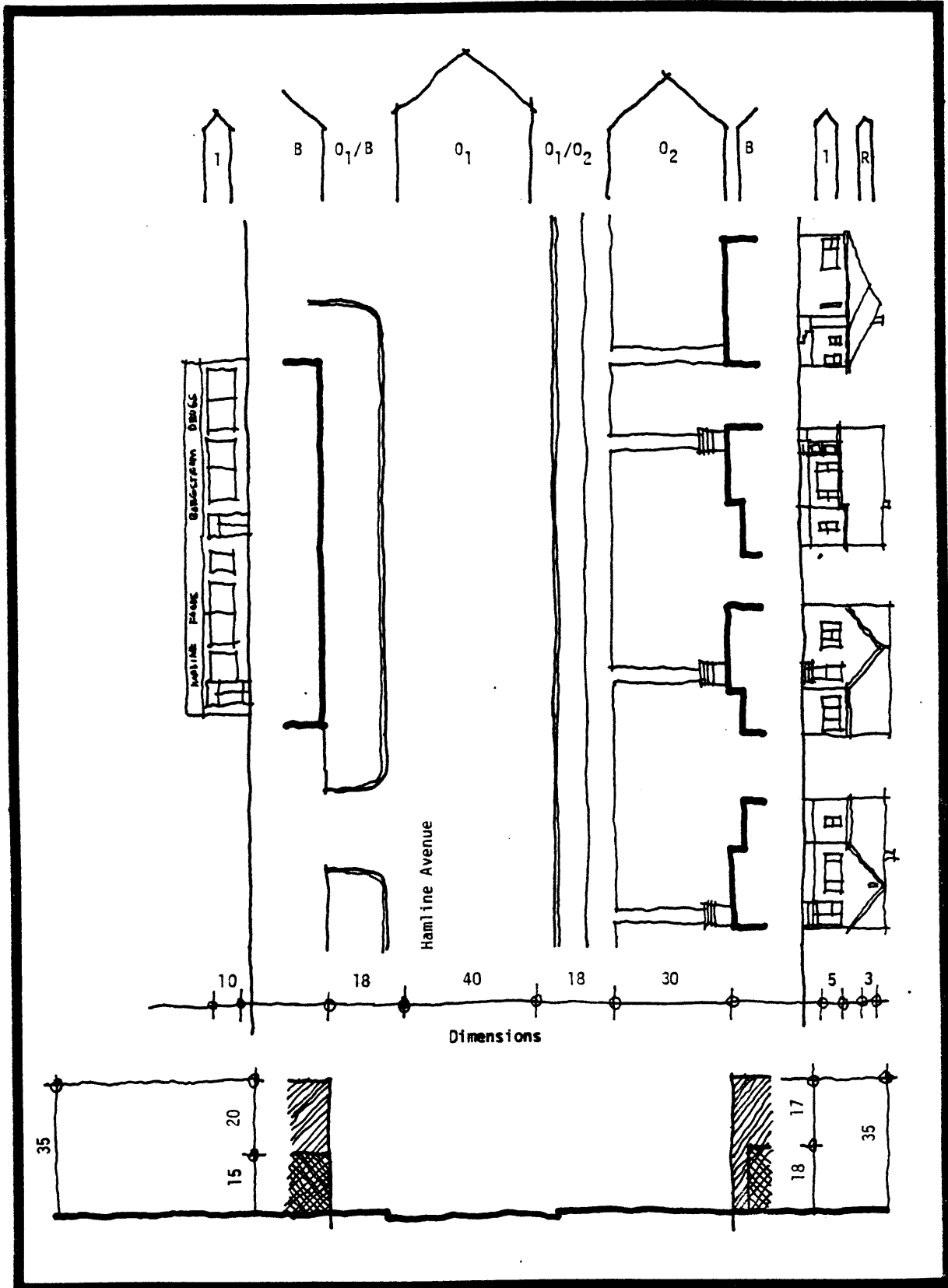

Figure 2-32

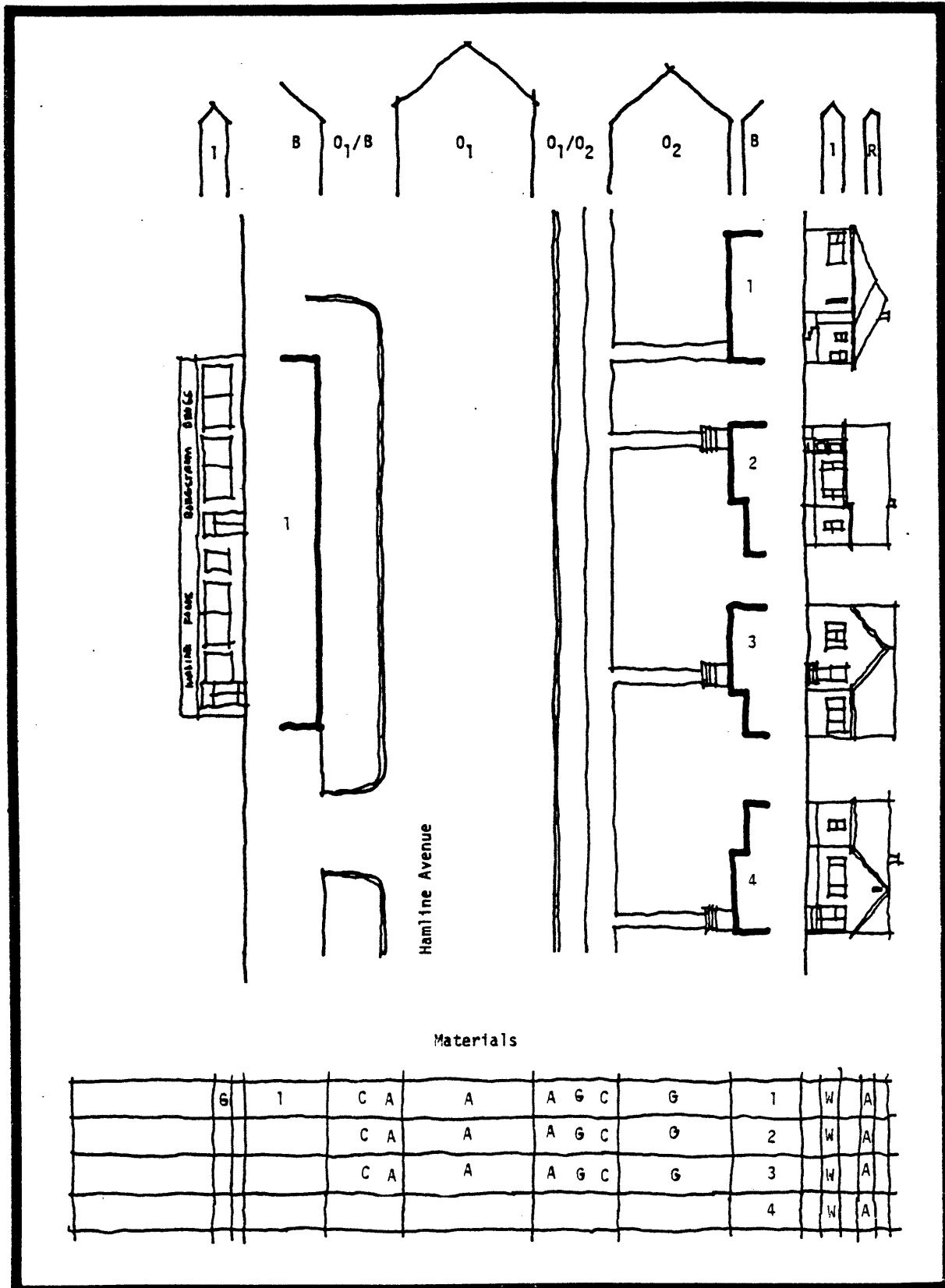

Figure 2-33

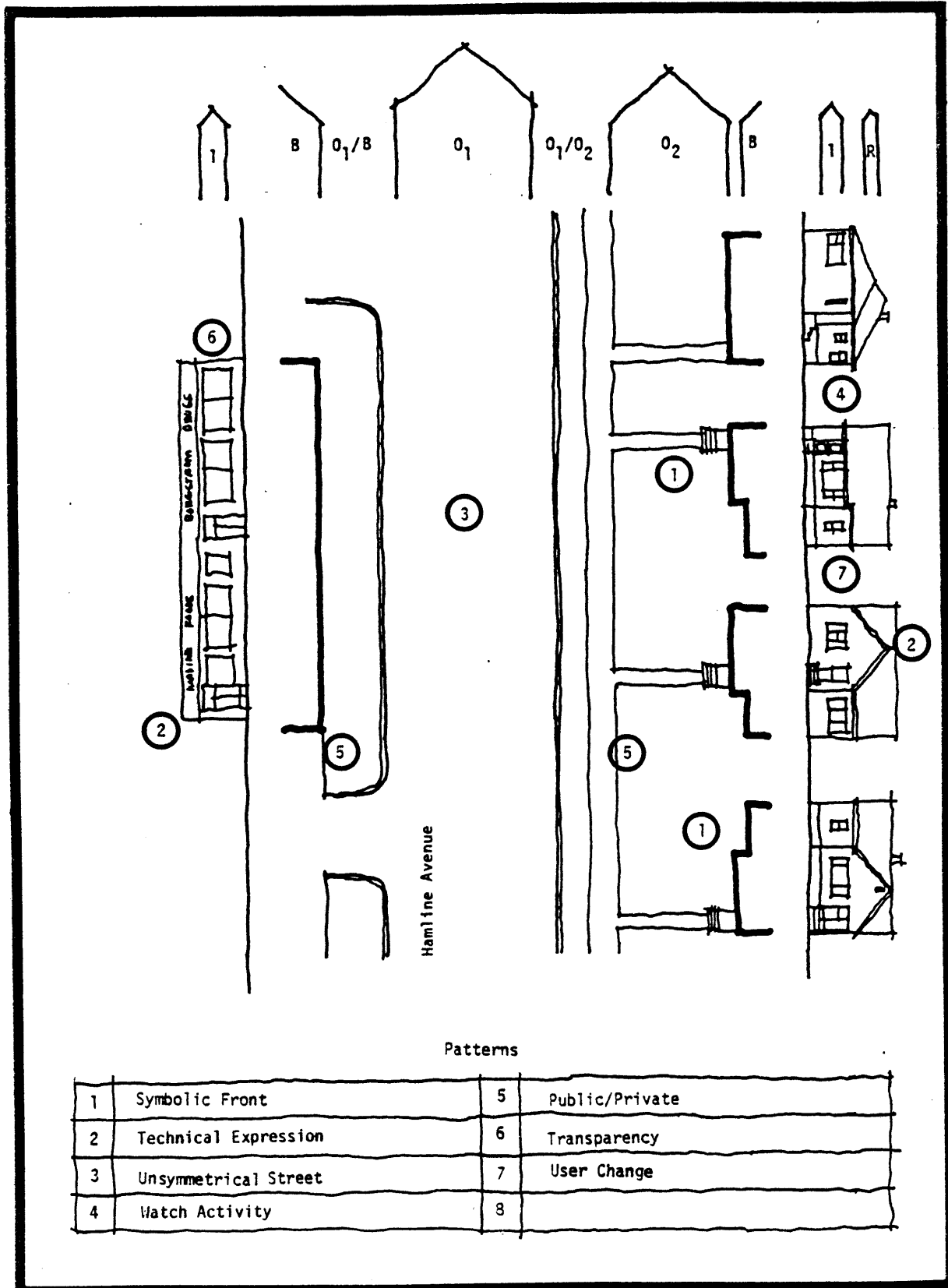

Figure 2-34

In order to establish a broader understanding of district, it is necessary to examine another district context. In this case it is a pedestrian mixed use district in Back Bay Boston (see Figure 2-35 and 2-36). The analytical format will be identical to that used to analyze Falcon Heights, Minnesota. This attached Block City district was subdivided in the latter half of the 19th century as the Back Bay was gradually filled in. The blocks were surveyed for row house communities and public streets for walking and horse-drawn carriages (see Figure 2-37). Over time the single family townhouses were subdivided into rental apartments, increasing the density of the area by a factor of four. As a functioning community, the district area was interspersed with churches, schools, and commercial buildings of compatible material and similar height and bulk. Non-thematic green open space was included too, with Commonwealth Avenue, then a large pedestrian boulevard terminating in the Fenway and the Public Garden.

The well-known character of the Back Bay is seen in Figure 2-35. Figure 2-37 shows a site plan of the Back Bay reduced to a scale of 1 inch equals 833 feet, similar to that of Falcon Heights. The equivalent scale is that of an airplane view at 6000 feet. The drawing looks from east to west, showing the boundaries that helped Back Bay Boston to develop the characteristics of this model district. The boundaries are the Charles River and Storrow Drive to the right, the Fenway to the top, Boylston Street to the left, and the Public Garden at the bottom of the page.

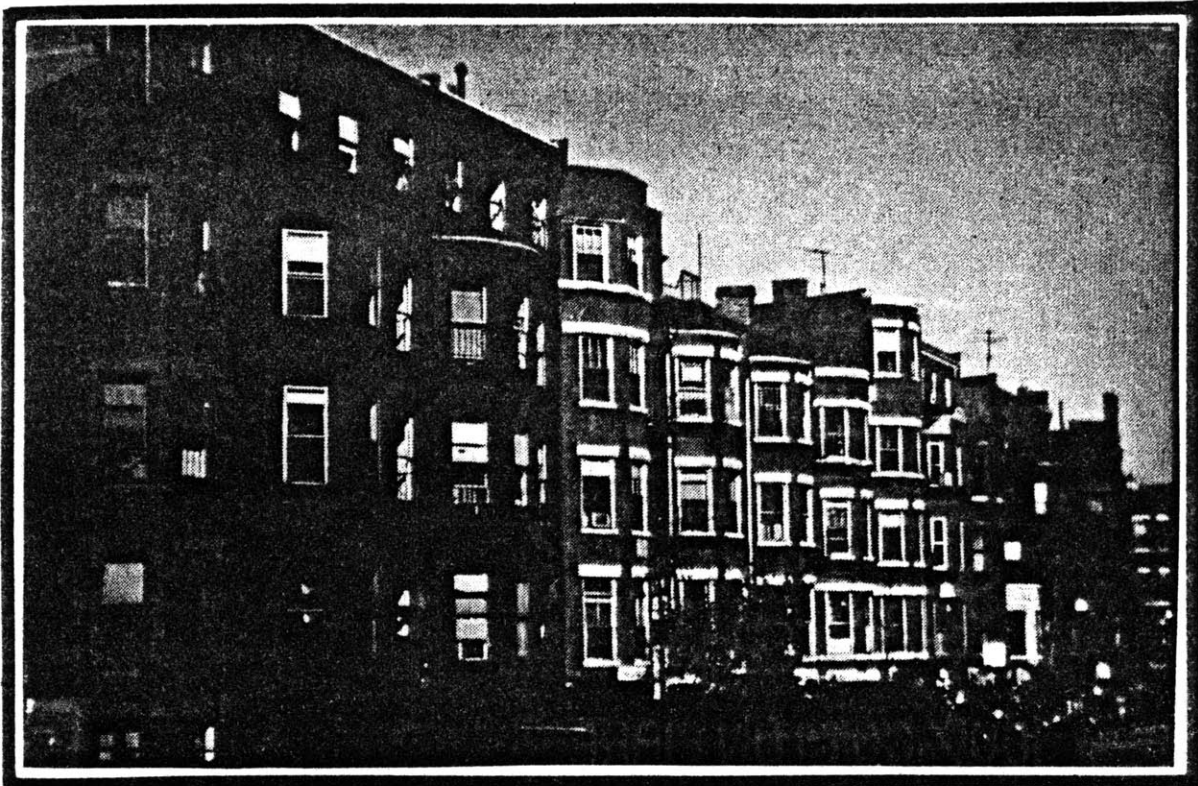

Figure 2-35

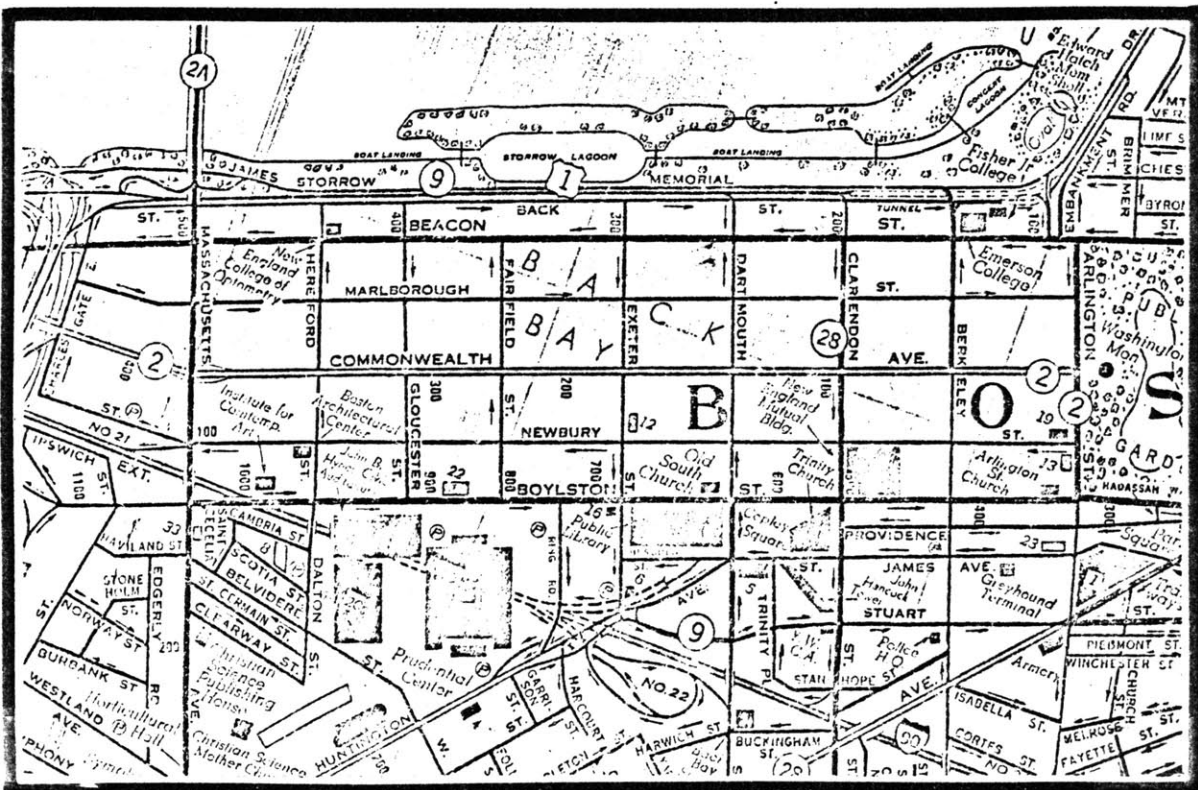

Figure 2-36

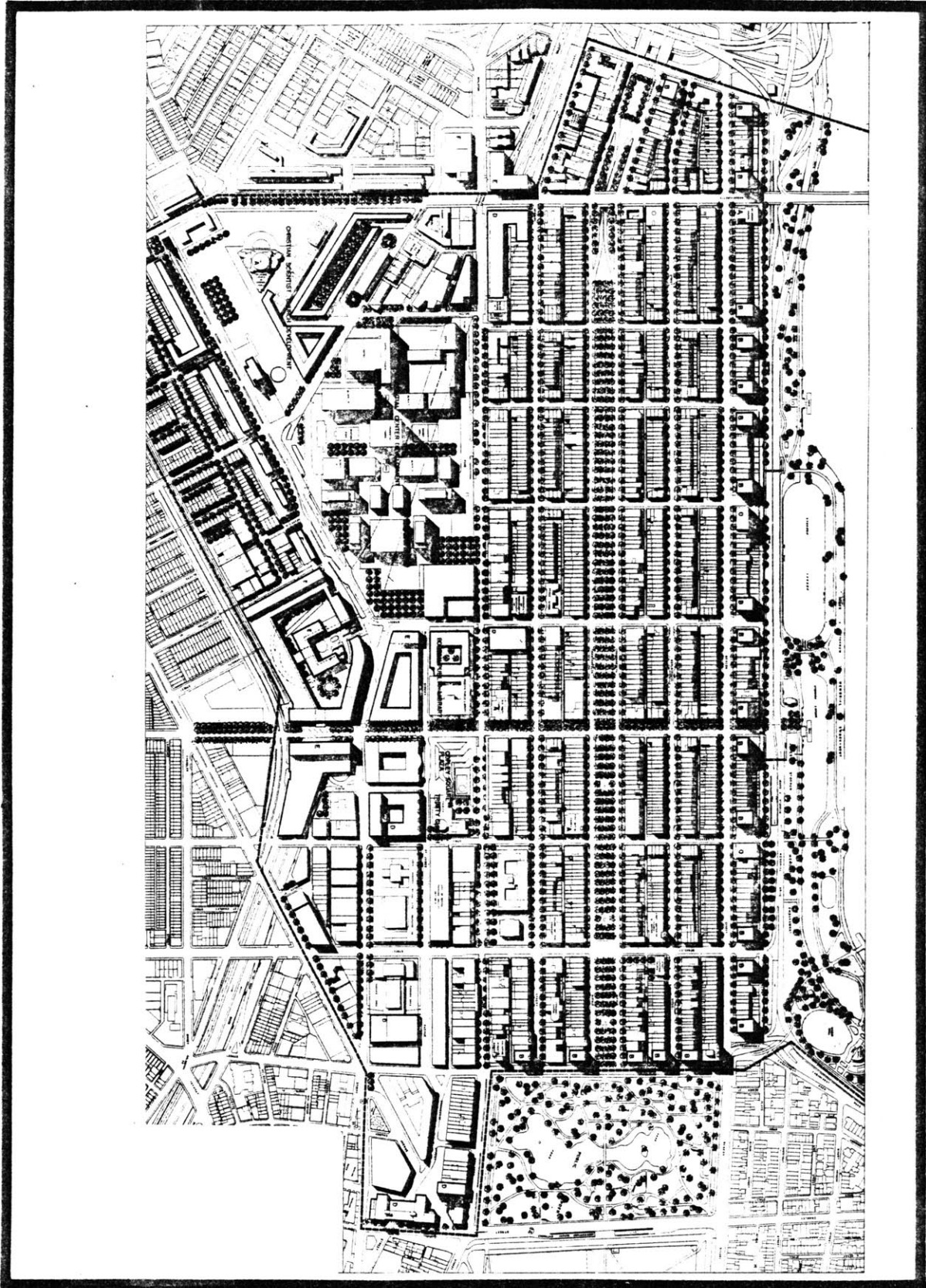

Figure 2-37

The remaining documents are similar to those we have developed in Falcon Heights. Figure 2-38 shows the historical growth of Back Bay including the Prudential Center intervention which was built in 1964. Figure 2-39 shows the built space, Figure 2-40 shows the open space elements, and Figure 2-41 shows the combined built and open space. Figure 2-42 shows in white the thematic district area which is based on the individual row house as a thematic unit (notice Study Block 3). Figure 2-44 shows the land use patterns, and Figure 2-44 shows the present zoning patterns. Figure 2-45 shows the planning levels at work in the Back Bay. Level 1 shows the action of the State of Massachusetts. Level 2 shows the action of the Boston Mayor, the City Council, and the Boston Redevelopment Authority. Level 3 shows the action of the Back Bay Historical District. Level 4 shows the action of local special interest groups at the neighborhood level, and the typical developer activity at Level 5. The cohesive nature of the Back Bay is maintained by the involvement of all the planning levels in new development review. This will be seen in greater detail in Chapter Three.

Figure 2-46 identifies the context of Block 3, and Figure 2-47 shows Block 3 in thematic and non-thematic elements. Figure 2-48 shows the land parcel subdivision of the late 19th century. Each parcel is 25 feet wide and 125 feet deep, one half the width and a similar depth to the study blocks in Falcon Heights. Consequently, this typical block is identical in size to Block One in Falcon Heights, 1,500 miles away and platted 80 years later.

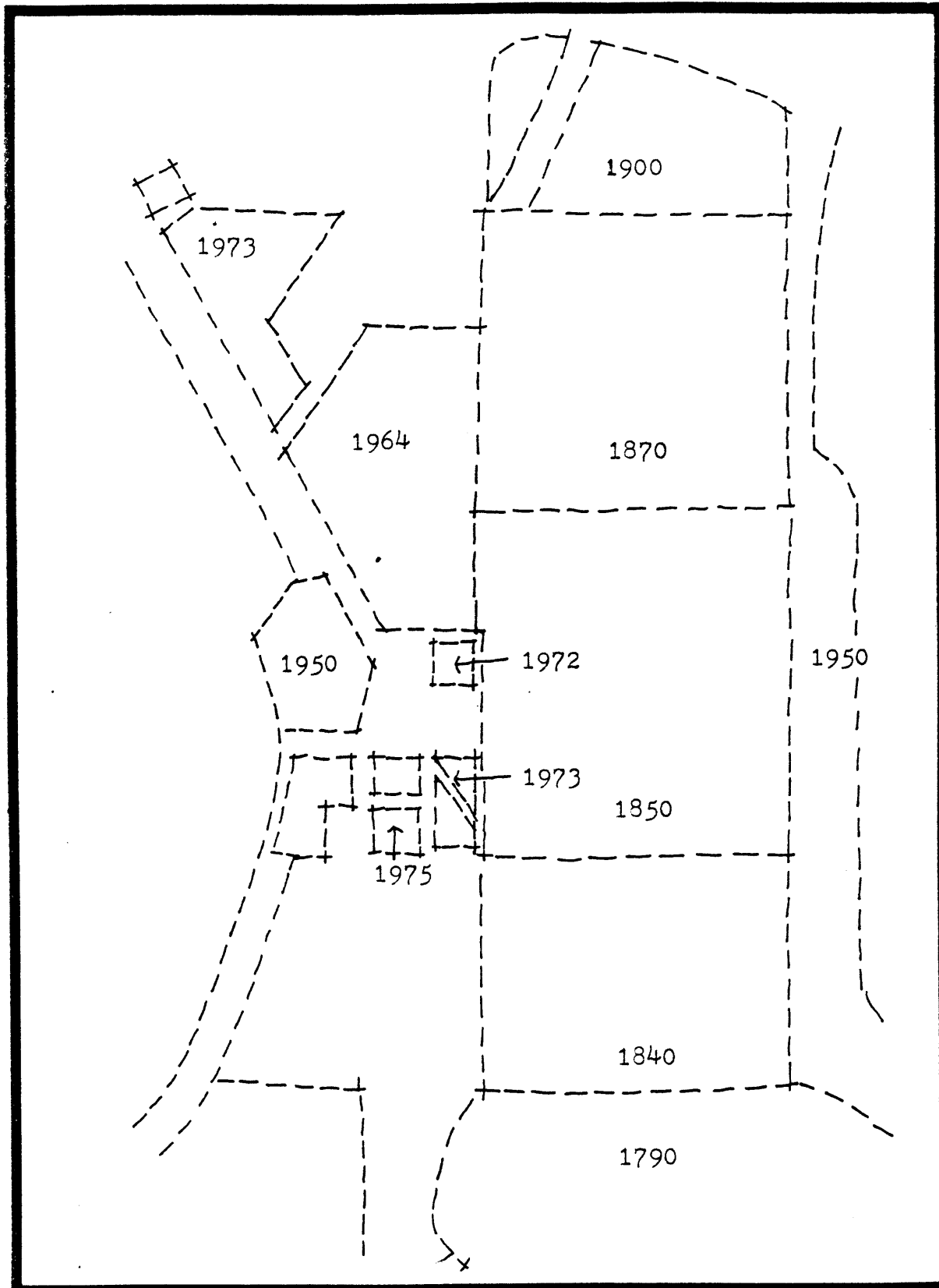

Figure 2-38

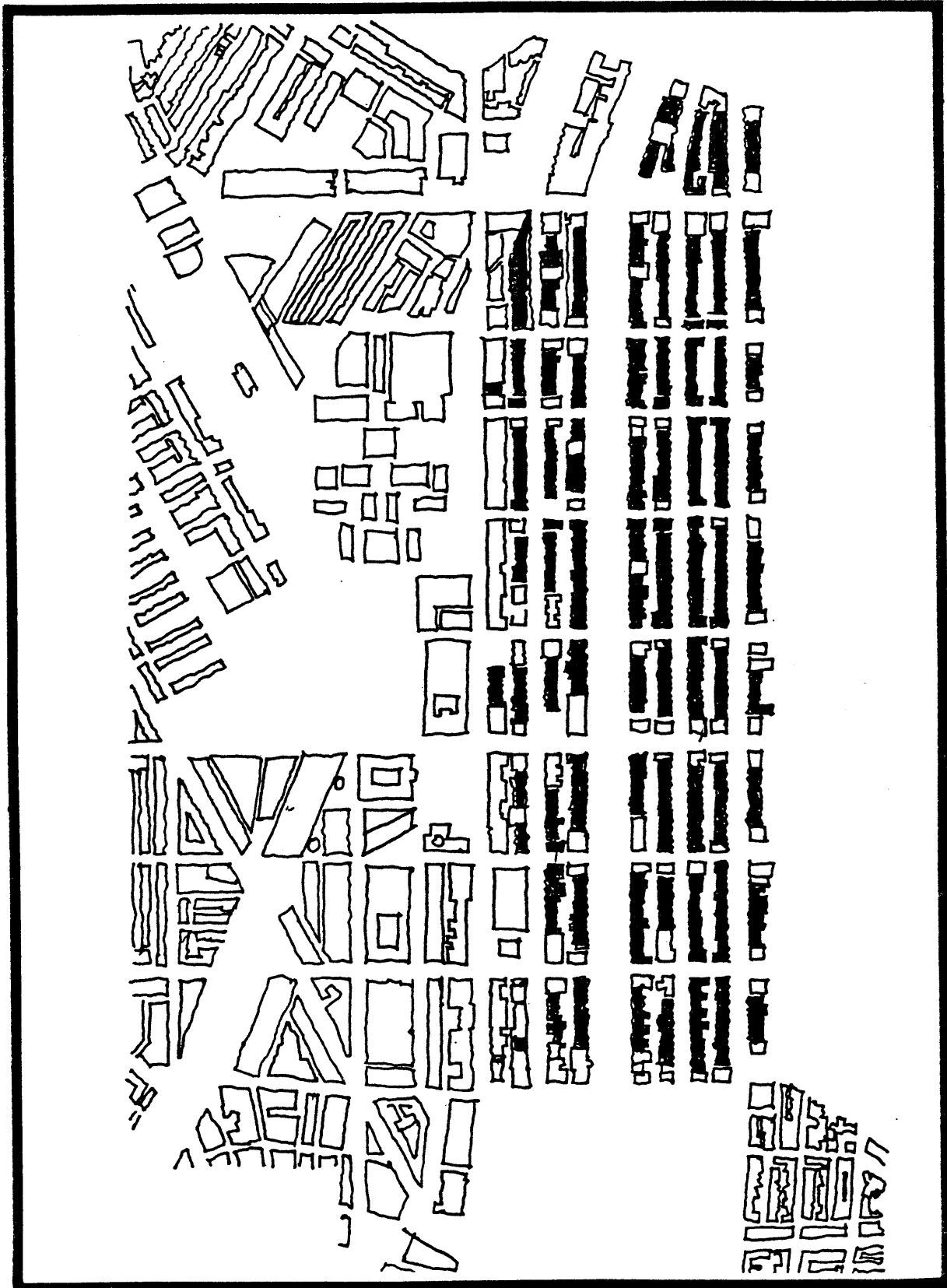

Figure 2-39

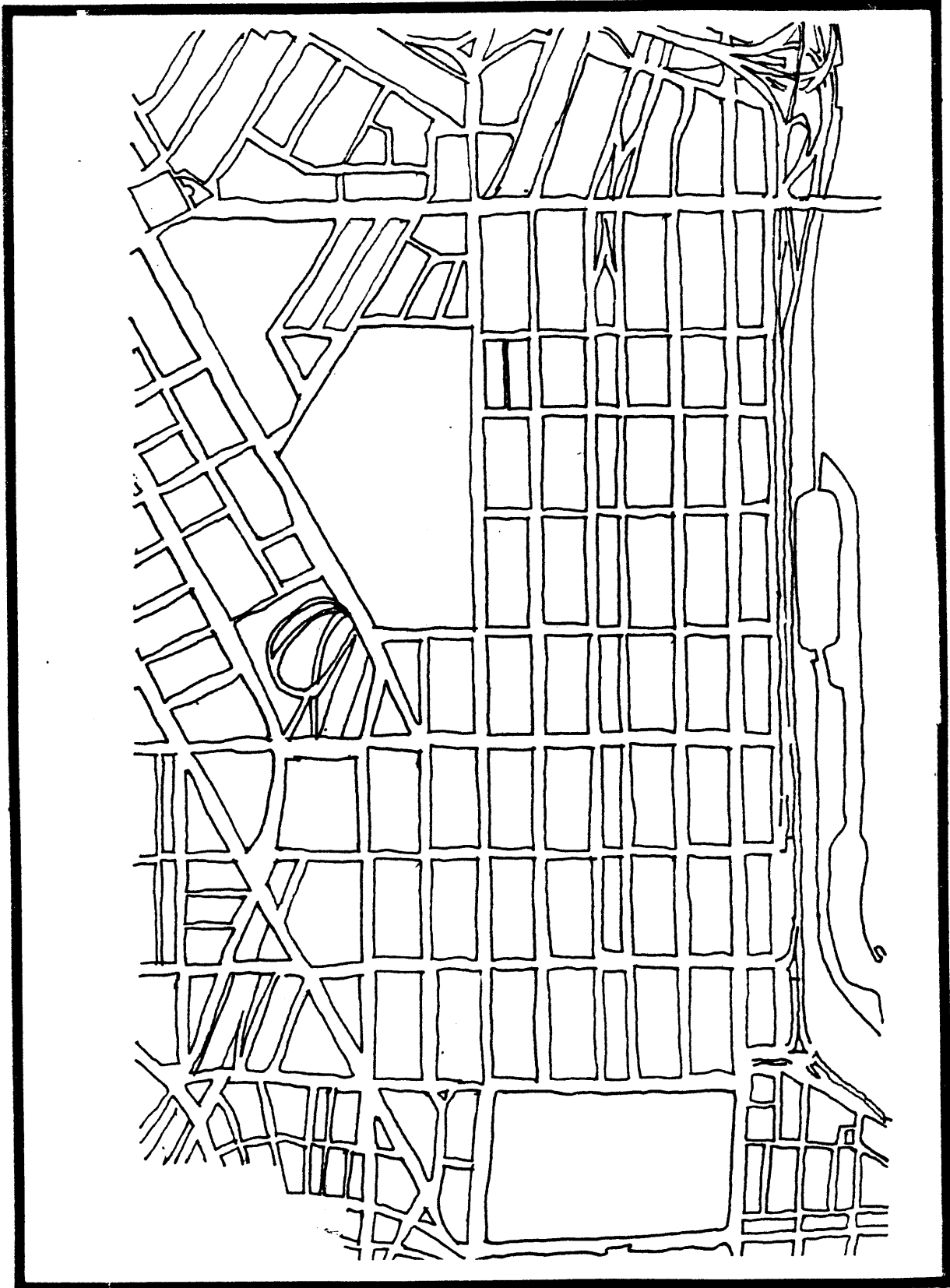

Figure 2-40

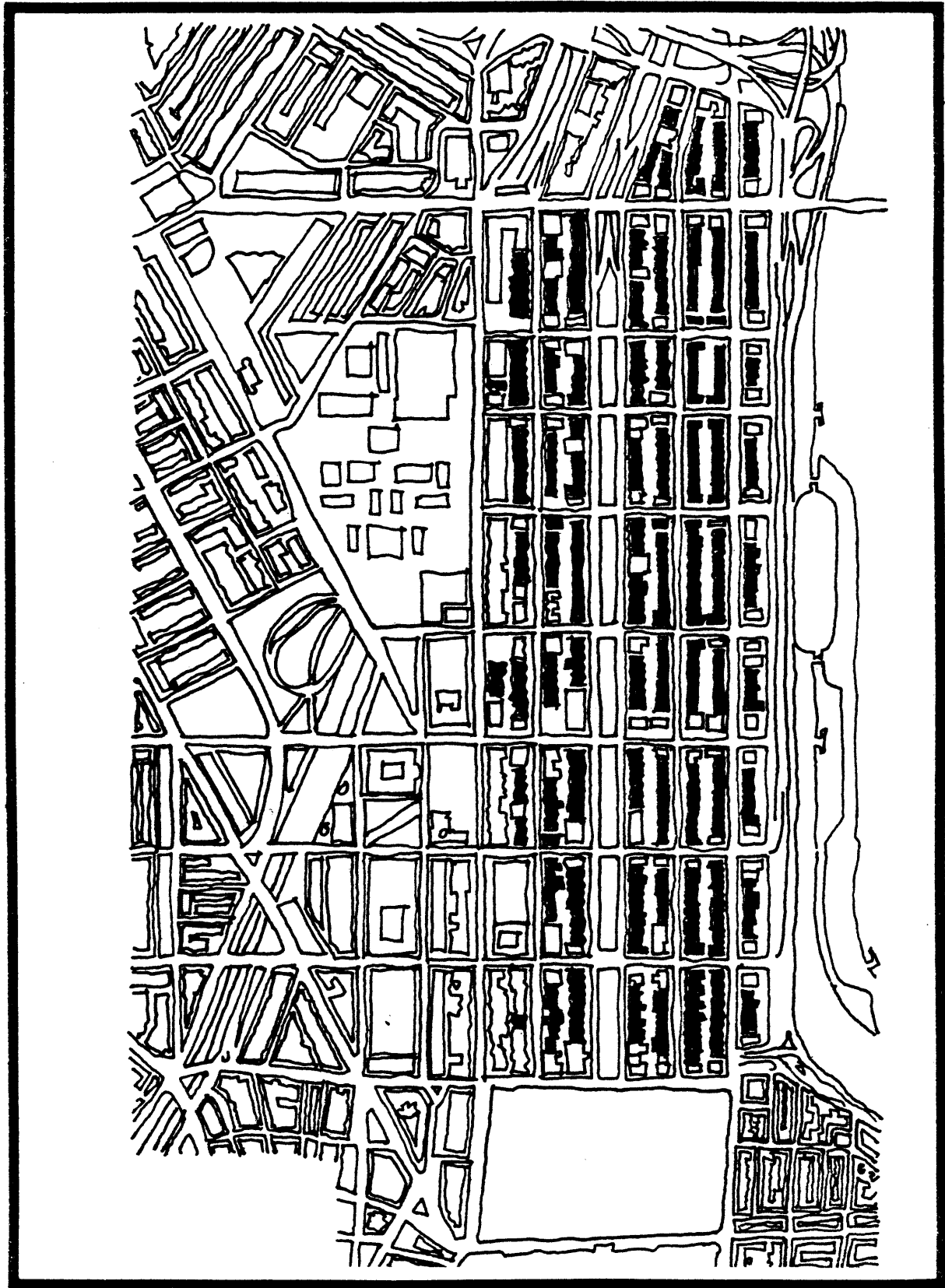

Figure 2-41

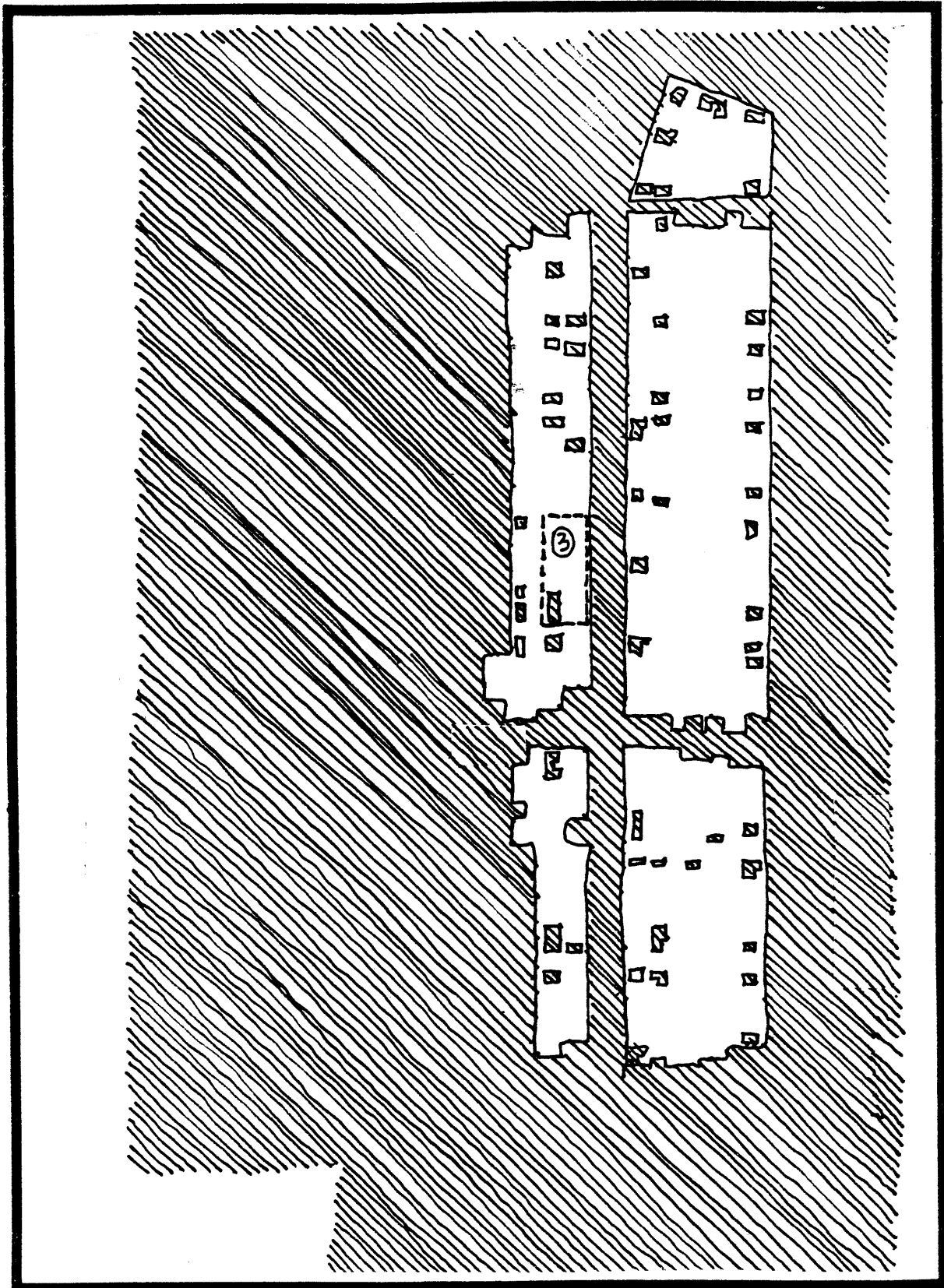

Figure 2-42

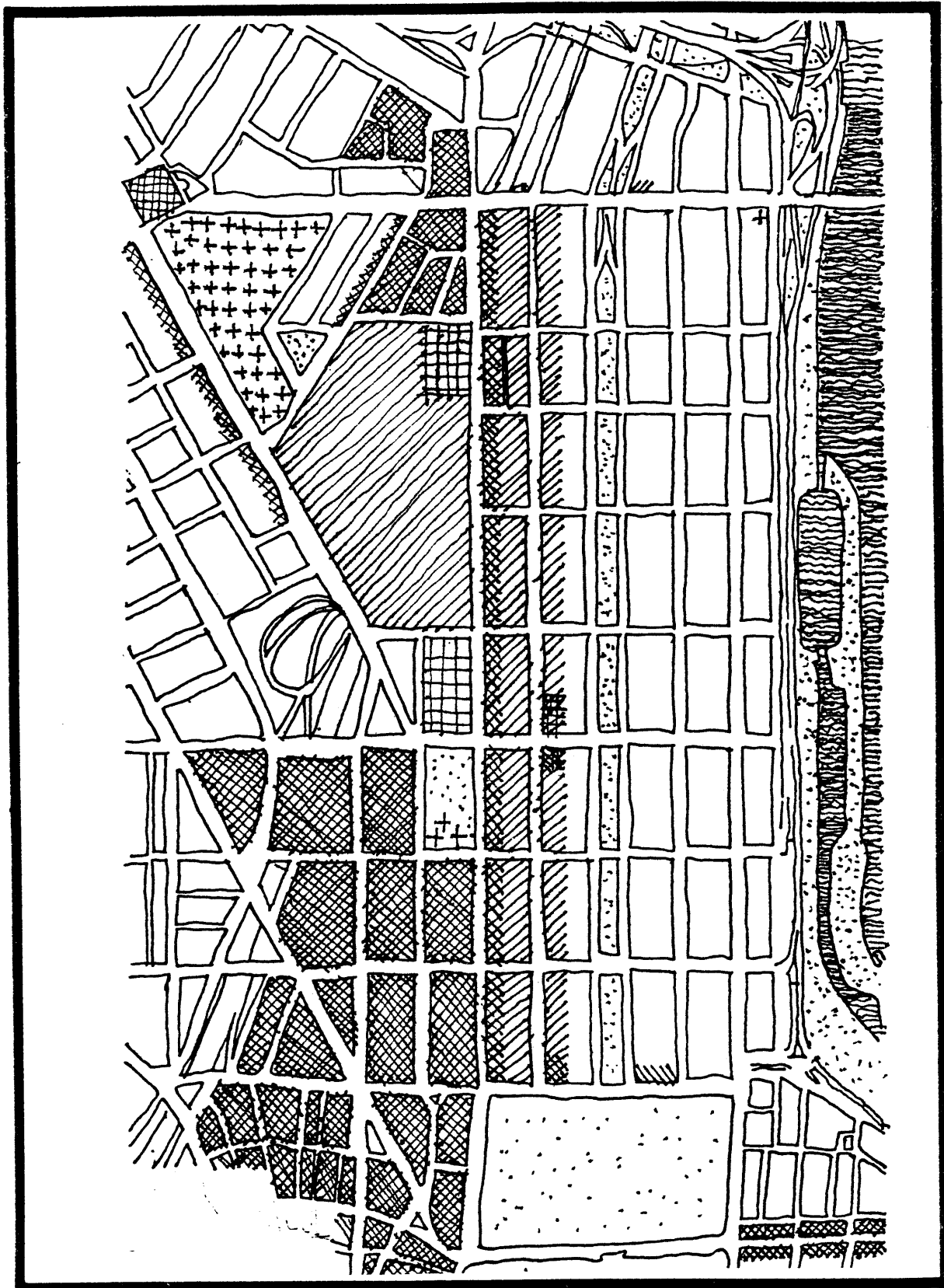

Figure 2-43

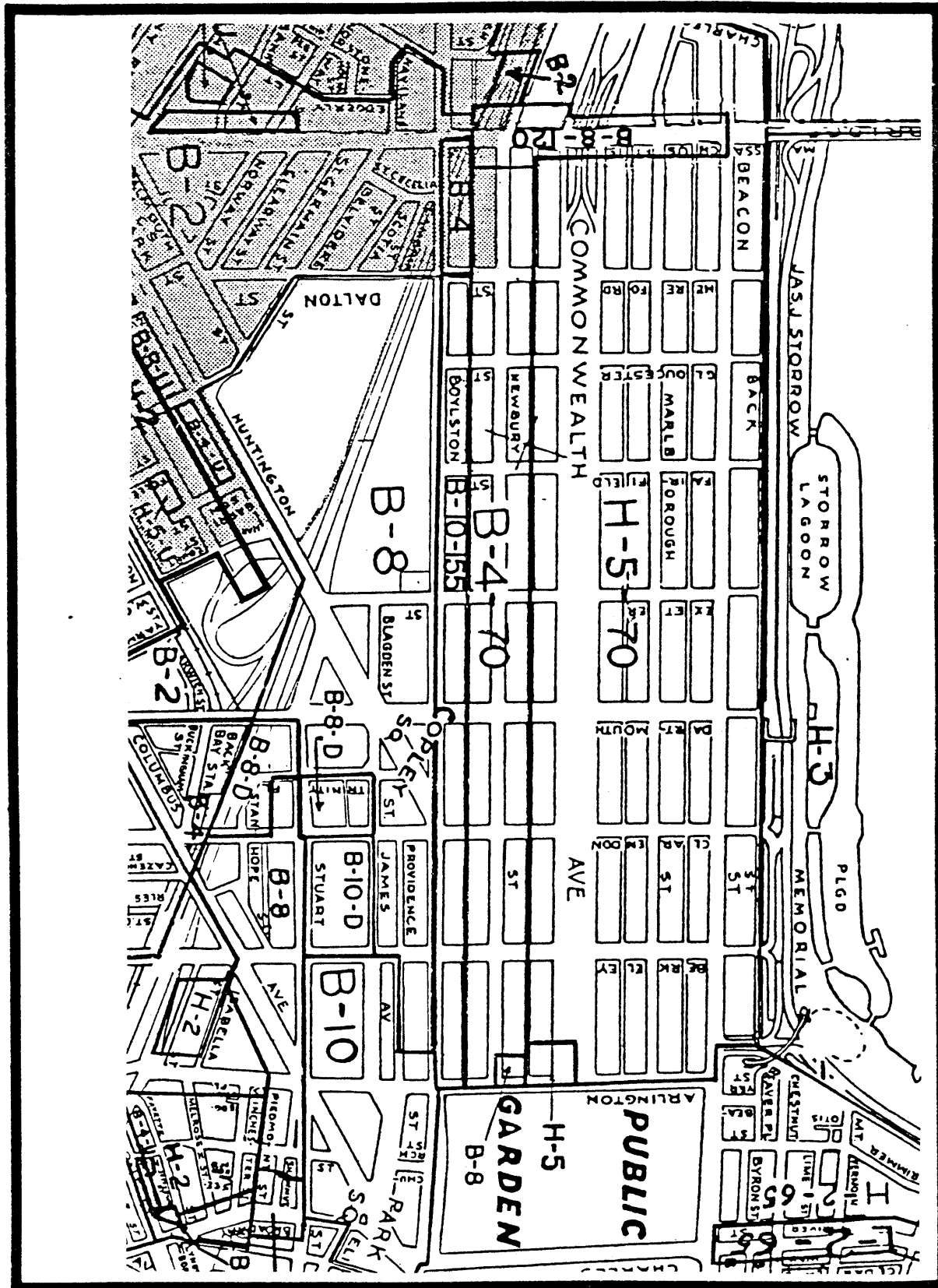

Figure 2-44

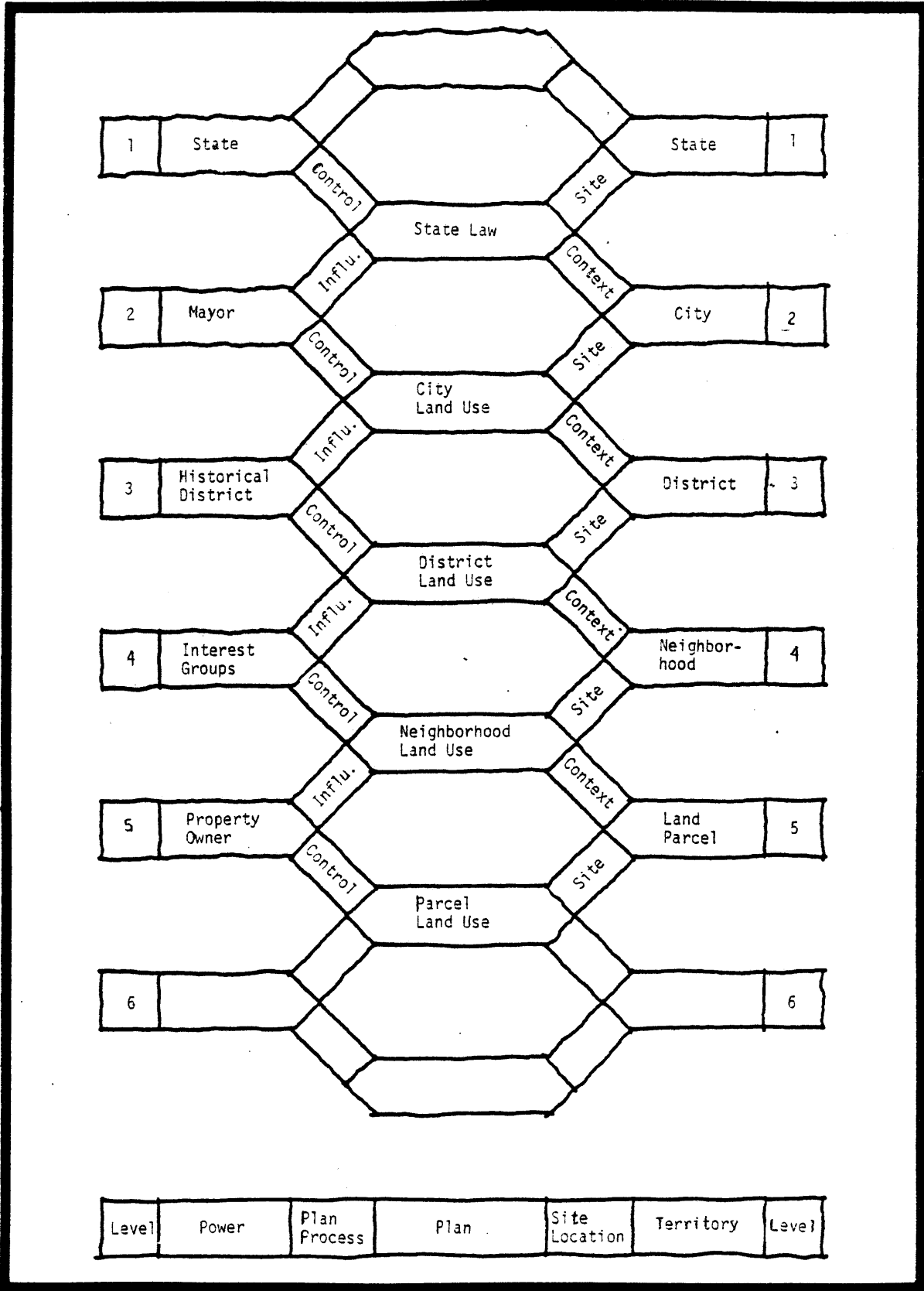

Figure 2-45

Figure 2-49 shows the roof plan of existing buildings. Figure 2-50 and 2-51 show the development of the built open space models. Figure 2-52 shows pathway diagram with regulatory requirements, and Figure 2-53 shows the patterns that exist on this symmetrical street. The patterns show one of the most attractive qualities of the area gained by mixed uses in a similar morphology. This occurs principally along Newberry Street as indicated in the zoning plan in Figure 2-44.

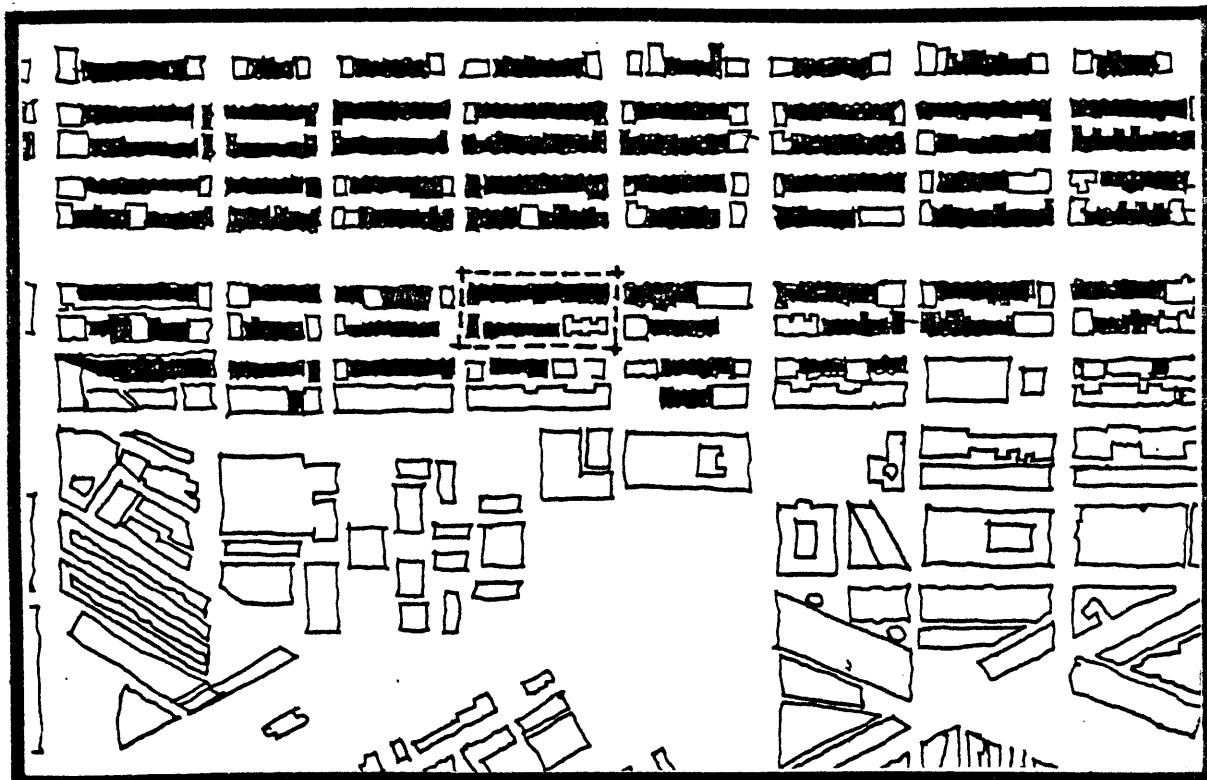

Figure 2-46

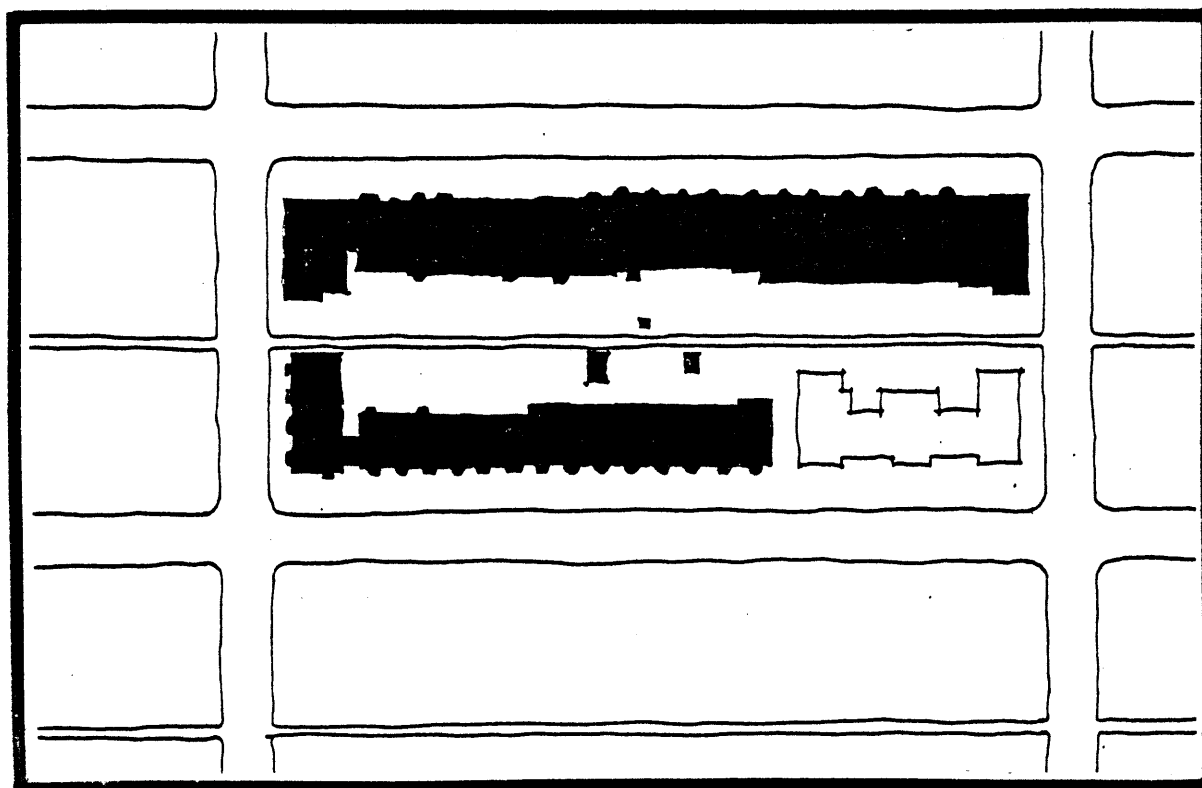

Figure 2-47

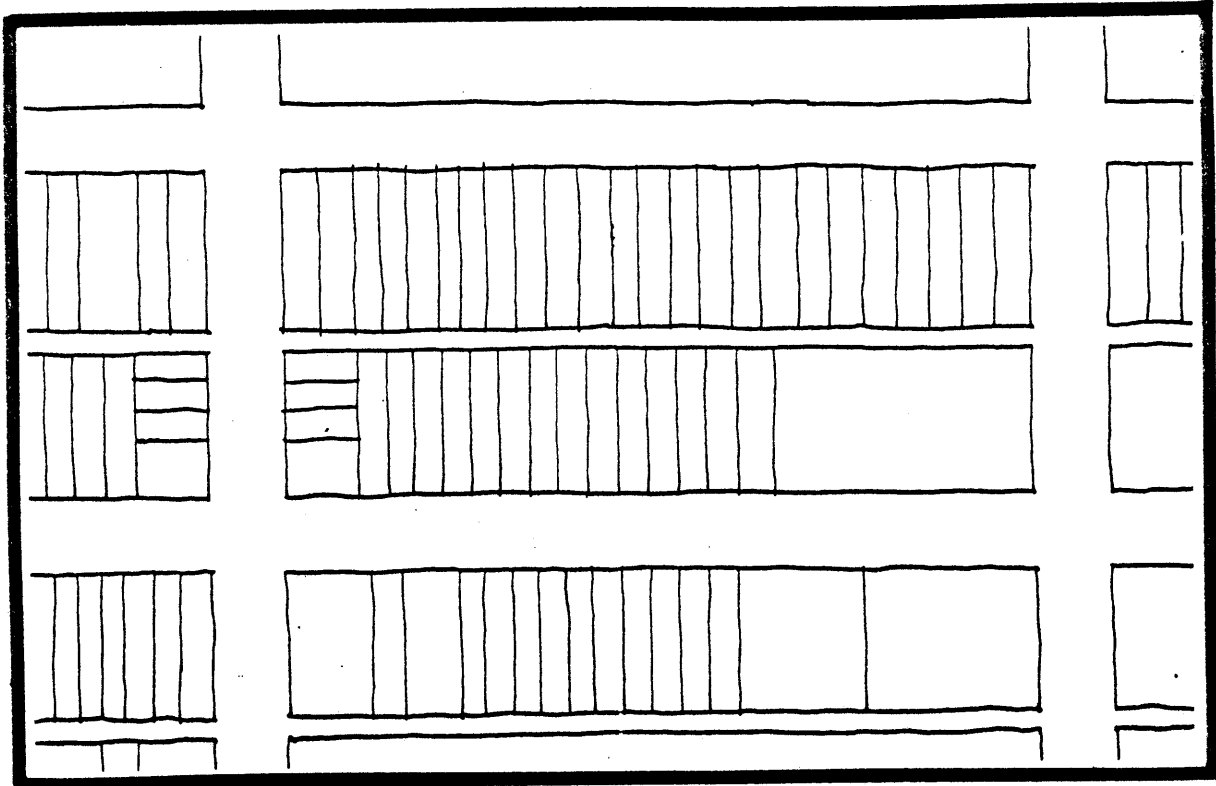

Figure 2-48

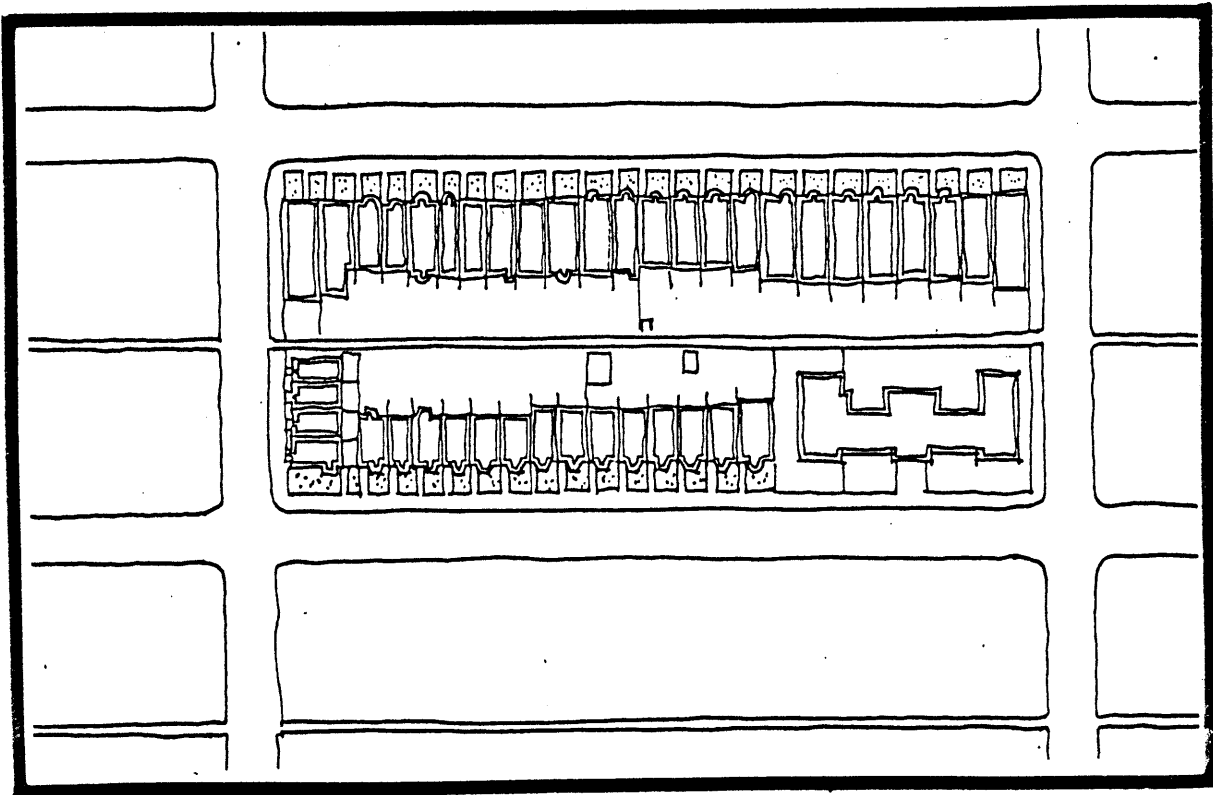

Figure 2-49

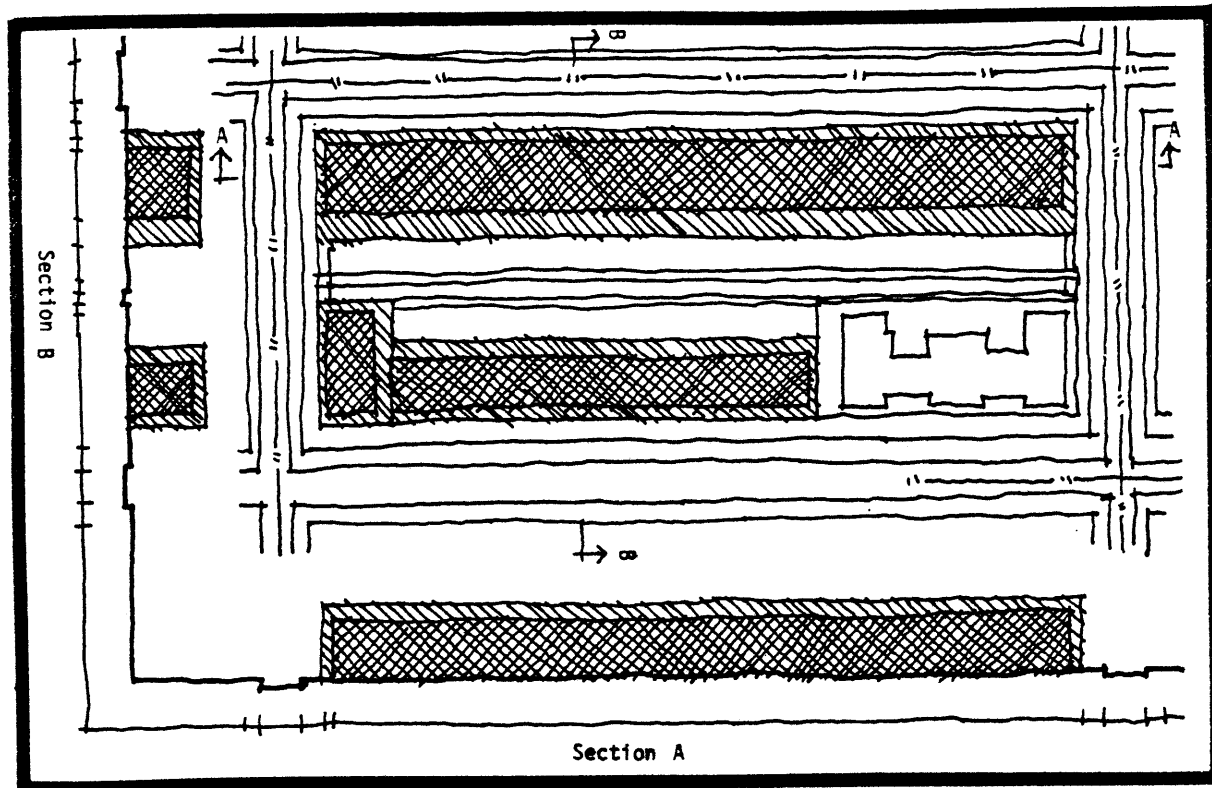

Figure 2-50

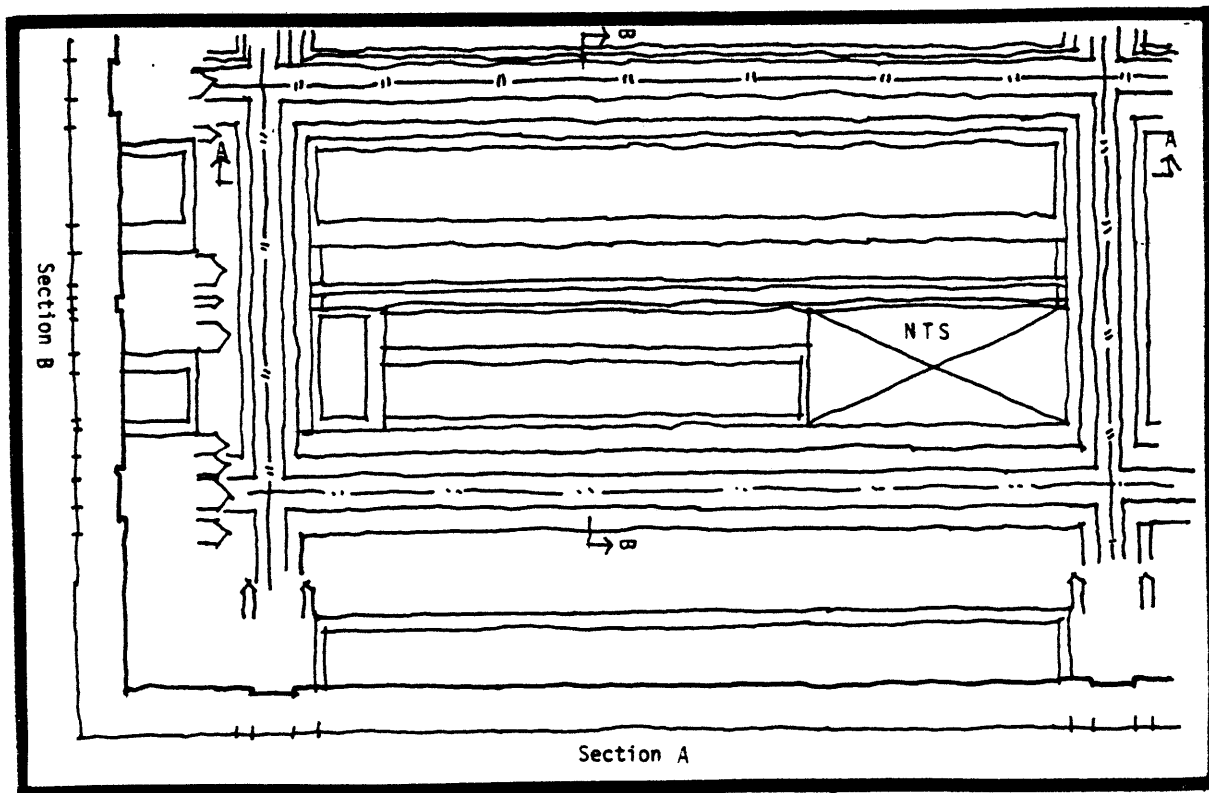

Figure 2-51

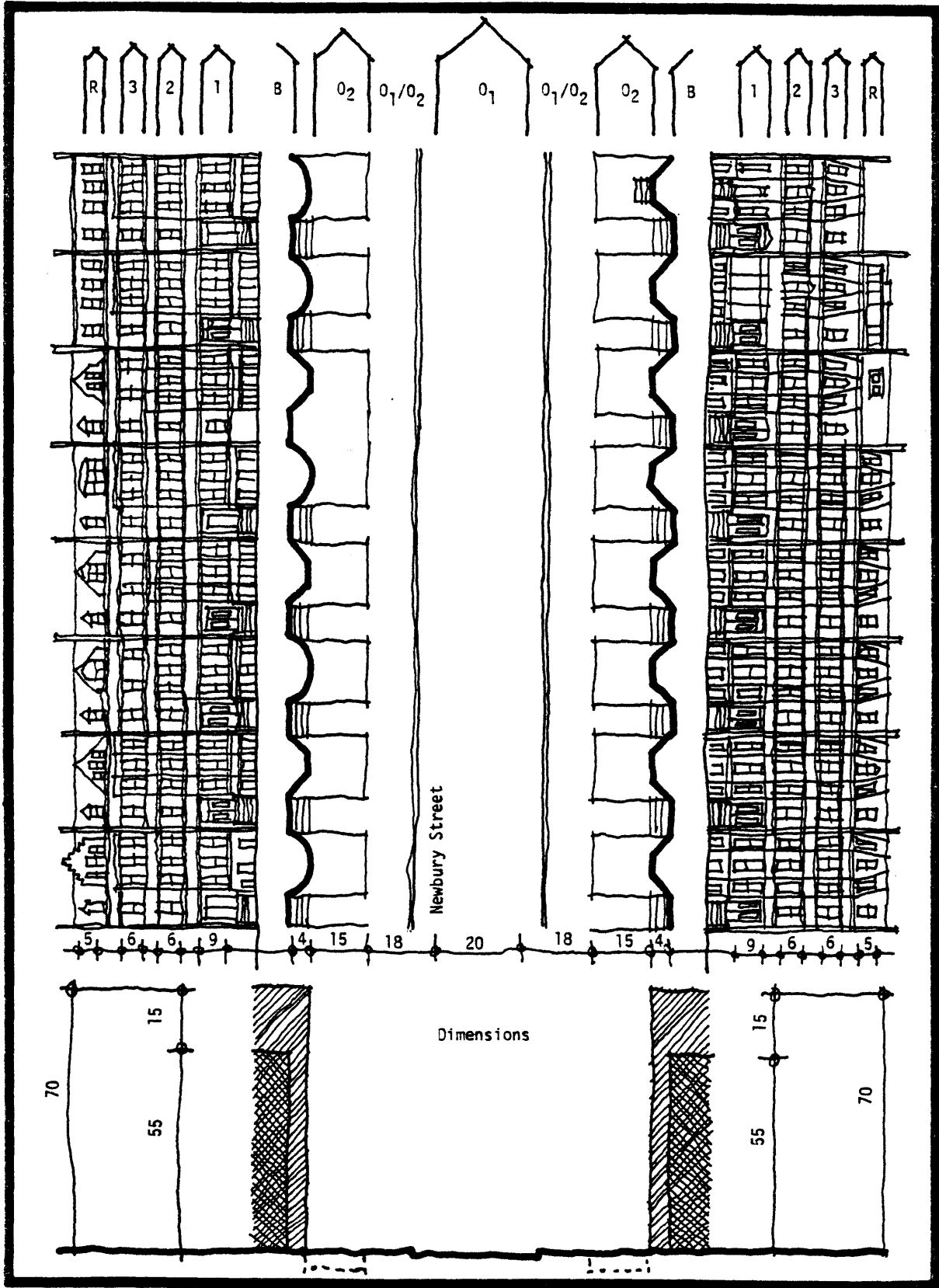

Figure 2-52

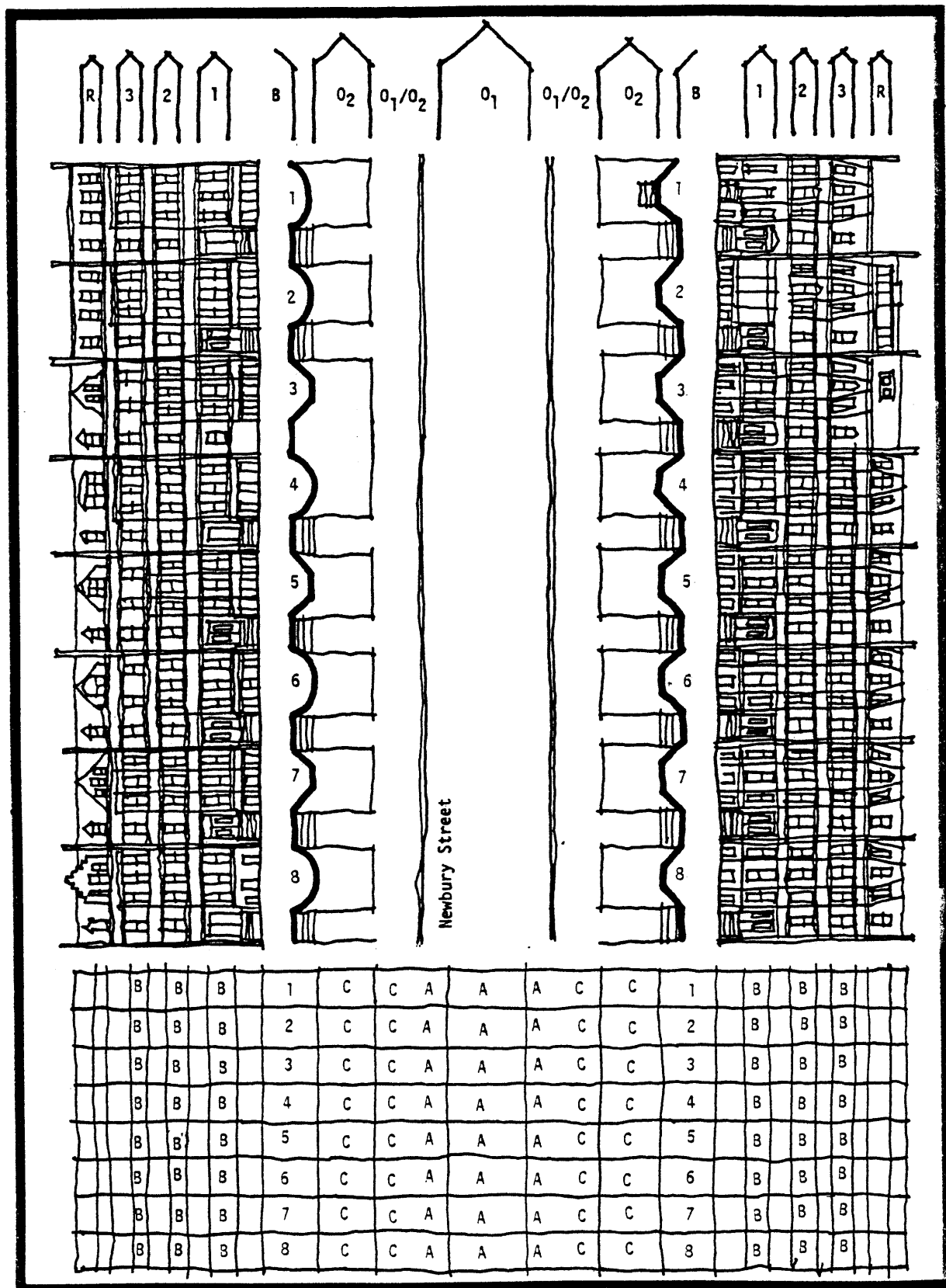

Figure 2-53

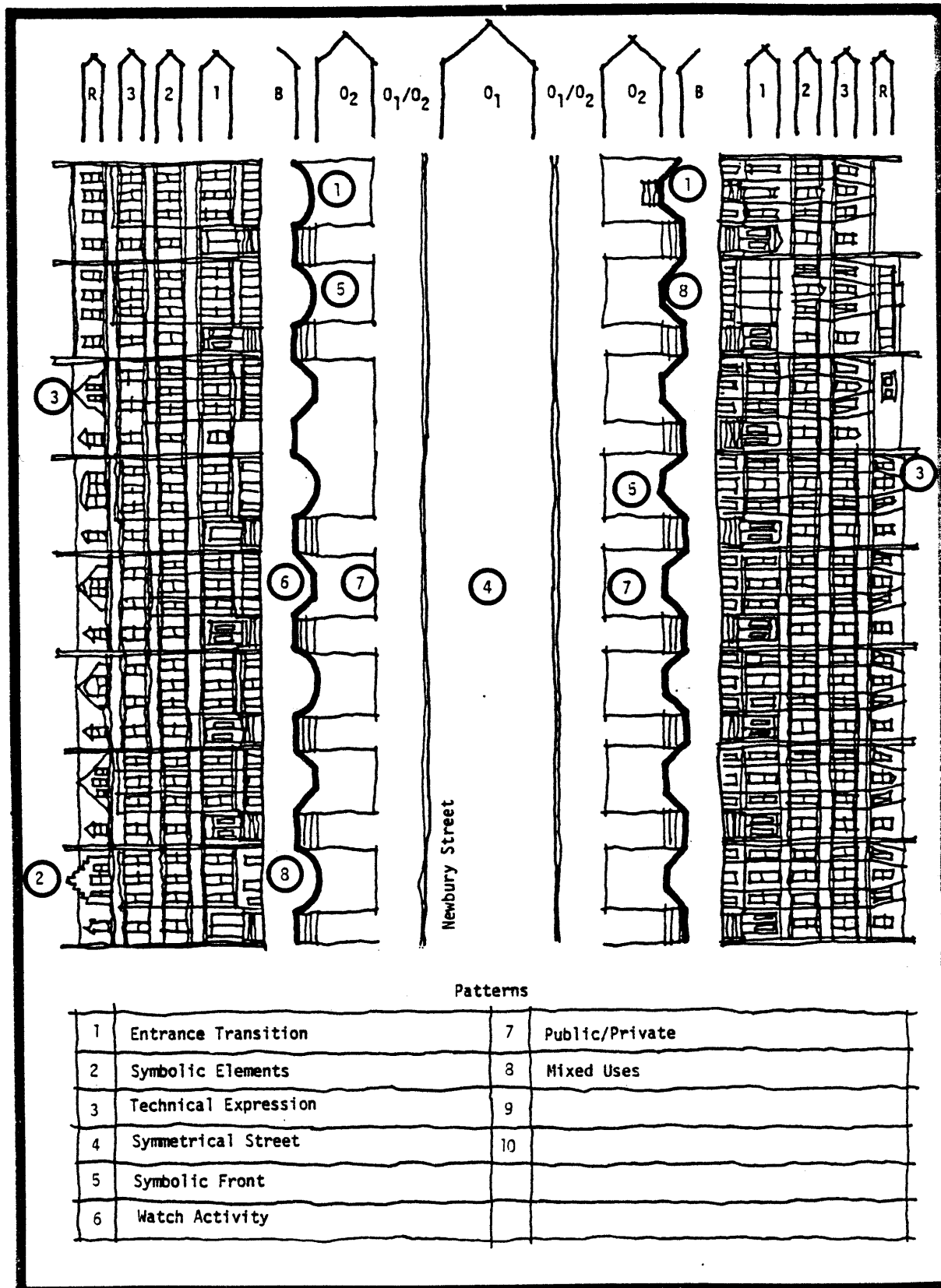

Figure 2-54

Given the pathway diagrams of the two districts, it is possible to compare their characteristics, knowing that they are separated by 1500 miles and 80 years in time.

Figure 2-56 shows the consistency of built space materials. Falcon Heights is constructed with three; Back Bay with two (excepting glass windows). In both cases they are used in consistent fashion and are painted, which gives a determined range of colors. Figure 2-55 shows the common regulatory characteristics. Knowing both pathways come from an identical block size, the O1 zones are similar, yet there is a vast difference in the O1 and O2 zones since Falcon Heights is single family housing while the Back Bay has row houses with higher original density, perhaps twice as high as Falcon Heights. Presently the Back Bay, with row house subdivisions, would be about 6 times denser than Falcon Heights, i.e. 54 du/acre vs. 9du/acre.

The pattern pathway shown in Figure 2-57 is more revealing as many patterns repeat, although the Back Bay has patterns for basement commercial development and mixed use within a similar morphology. The patterns here are in fact universal and are commonly found around the world as expressions of medium density living and a relatively well developed pedestrian network.

Now we have developed a method by which we can describe districts in terms of their built and open space organization, as well as how control of these built and open space patterns occur in different settings by examining their level diagrams.

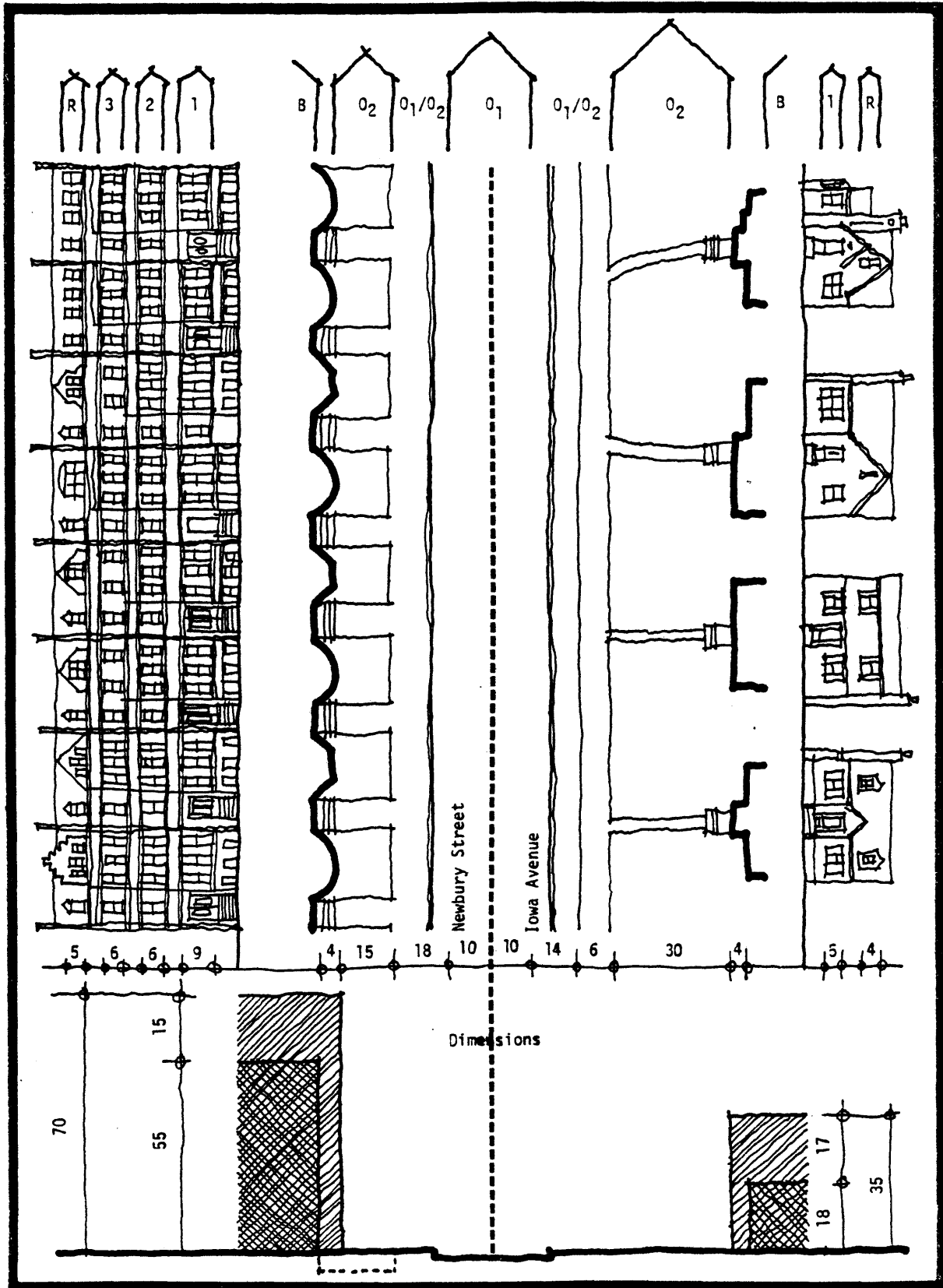

Figure 2-55

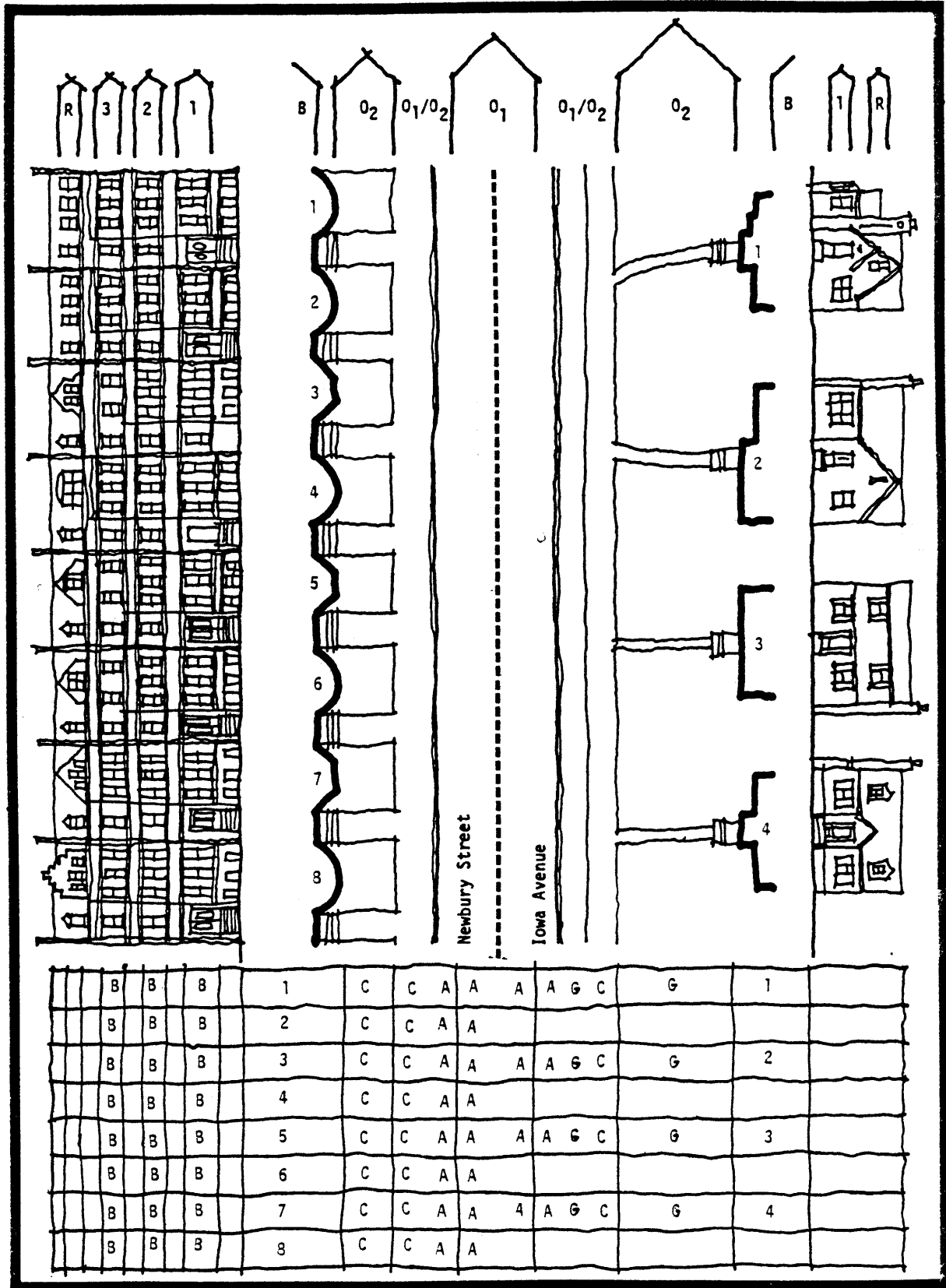

Figure 2-56

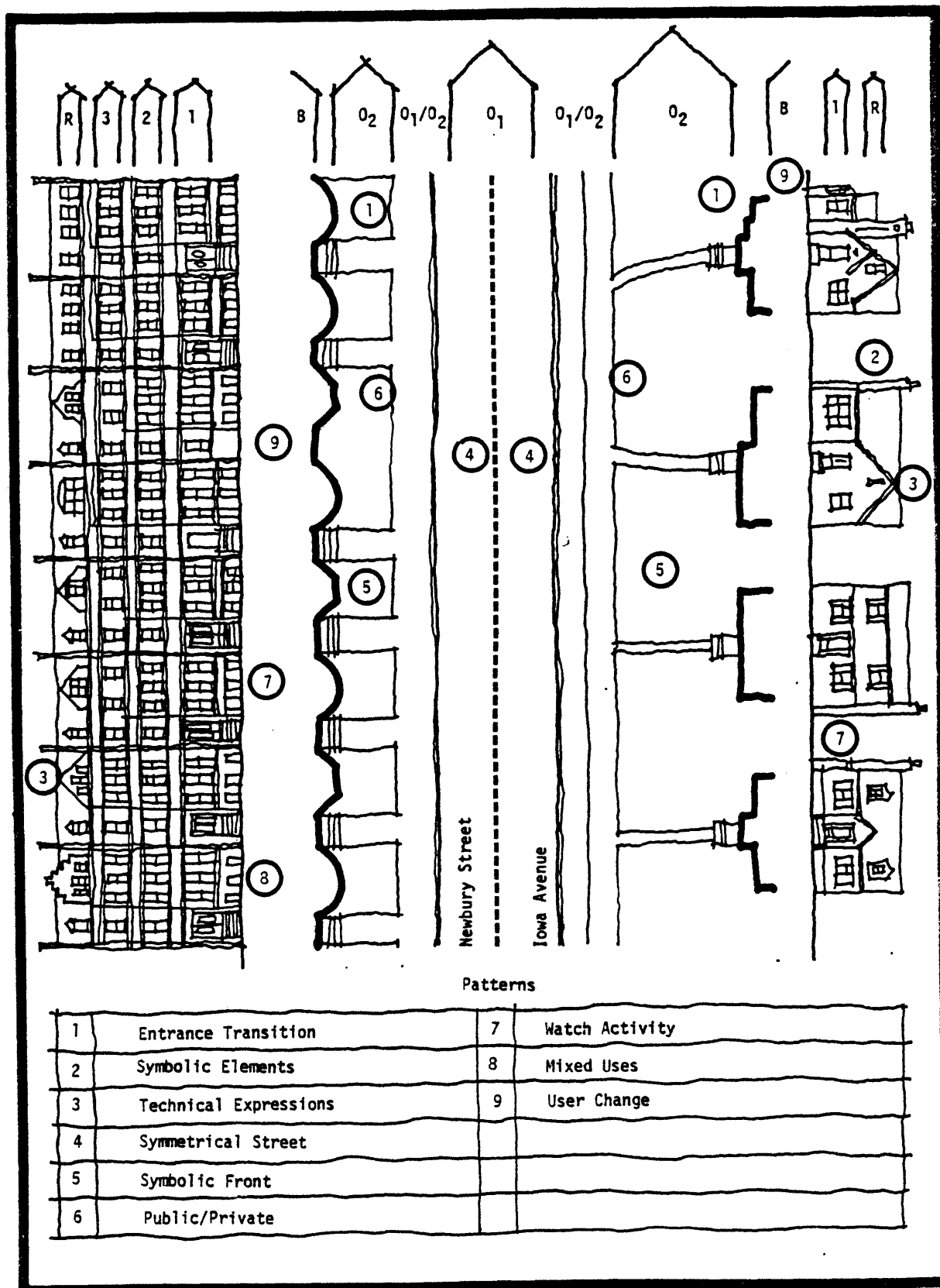

Figure 2-57

From these analytical techniques we can establish the characteristics of a district as a regular occurrence of built and open space, patterns which can be seen as thematic and non-thematic conceptualization. In addition, in examining the district from an observer's viewpoint, we see that other issues contribute to this district quality such as the similarity of materials, dimensions, and patterns.

Through comparison we saw that each district shared these qualities. Now given this analytical approach, we can see how different interventions can strengthen or destroy existing district qualities. Such a study will help us in forming a design guideline structure for Elliot Park.

Chapter Three

District Interventions

In this chapter we will consider those circumstances under which development interventions have worked to preserve contextual qualities or have ignored them in the fulfillment of a development program. To examine a range of typical development activity, we will look at five case studies in St. Paul, Boston, and Minneapolis because they provide evidence on representative issues and levels of design activity.

The case study subjects are as follows: a residential infill development in Ramsey Hill, St. Paul; mixed use infill development in the Back Bay Historical District in Boston; a for-profit housing development in the Powderhorn neighborhood in Minneapolis; a non-profit community development housing project in South End in Boston; and a public sector/private sector housing development in the Loring Park Tax Increment Development District in Minneapolis.

The analysis in each case will graphically describe the existing Block City districts and the new intervention. The interventions are shown as follows:

1. new construction--diagonal lines
2. rehabilitated existing structures--cross-hatched lines
3. relocated structures--vertical lines
4. buildings removed to improve contextual quality--horizontal lines

The existing context is described as follows:

1. non-thematic buildings--white
2. thematic buildings--black

It is hoped that through casual inspection that the reader can discern the differences and similarities between the intervention and the context.

The specific comparison of the intervention will be done via the pathway diagram which will measure materials, color, and patterns, the variants used on the pathway diagram are marked "C" for context and "I" for intervention on the drawings of the study area.

The case study locations are shown on the following maps (see Figure 3-1).

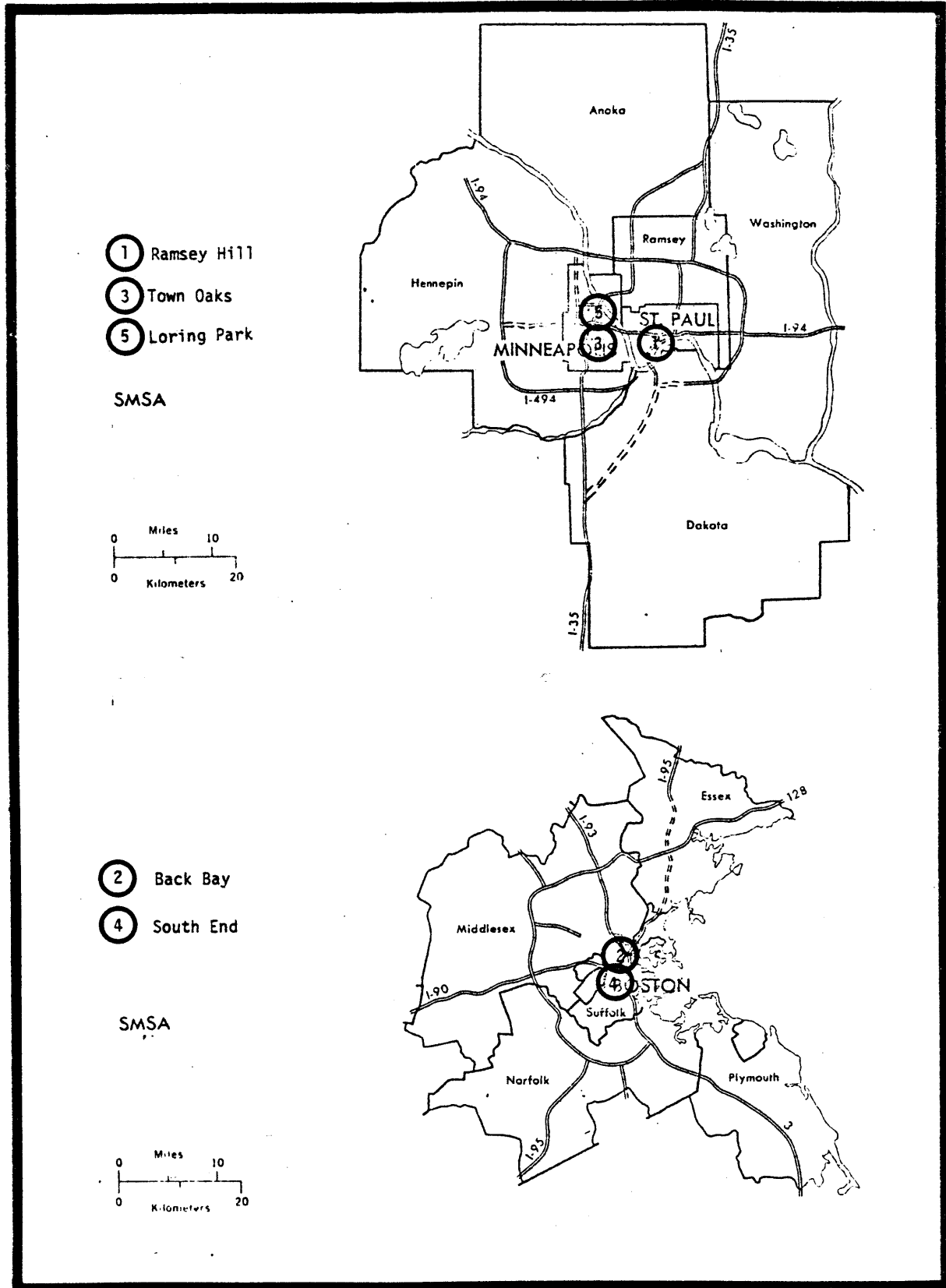

Figure 3-1

Summit Place, St. Paul, Minnesota

In the spring of 1974, Bob Engstrom, an experienced condominium developer, decided to buy a parcel of land in the Model Cities neighborhood of Selby-Dale near the Ramsey Hill district in St. Paul. The Ramsey Hill district developed with mansions belonging to the city's aristocracy--the lumber, milling, railroad, and mining barons who developed the economy of the northwestern United States. The area built up gradually from 1880 through 1920, when it was fully developed. Its most prominent period was in the pre-Depression 20's when one of the neighborhood's international successes, F. Scott Fitzgerald, lived in one of its stately row houses. The combination of large, ornate mansions, broad, elm-covered streets, and gas-lit sidewalks created a neighborhood of aristocratic elegance.

With the Depression and the war, the area declined. In typical pattern the mansions were subdivided and the area absorbed the lower classes as the children of the aristocracy left their childhood neighborhoods for the expanding post-war suburbs. With the construction of the inter-city freeway I-94 between Minneapolis and St. Paul in 1970, the area absorbed the displaced black community whose homes had been demolished for freeway construction. The blacks settled in the Selby-Dale neighborhood, an urban renewal area adjacent to Ramsey Hill which had many of its "blighted" homes removed. Later the area was to be a Model Cities neighborhood.

In the early 70's the Ramsey Hill area, with its stately, irreplaceable mansions, became attractive to the young professional classes who enjoyed the proximity to the St. Paul CBD, only 30 minutes

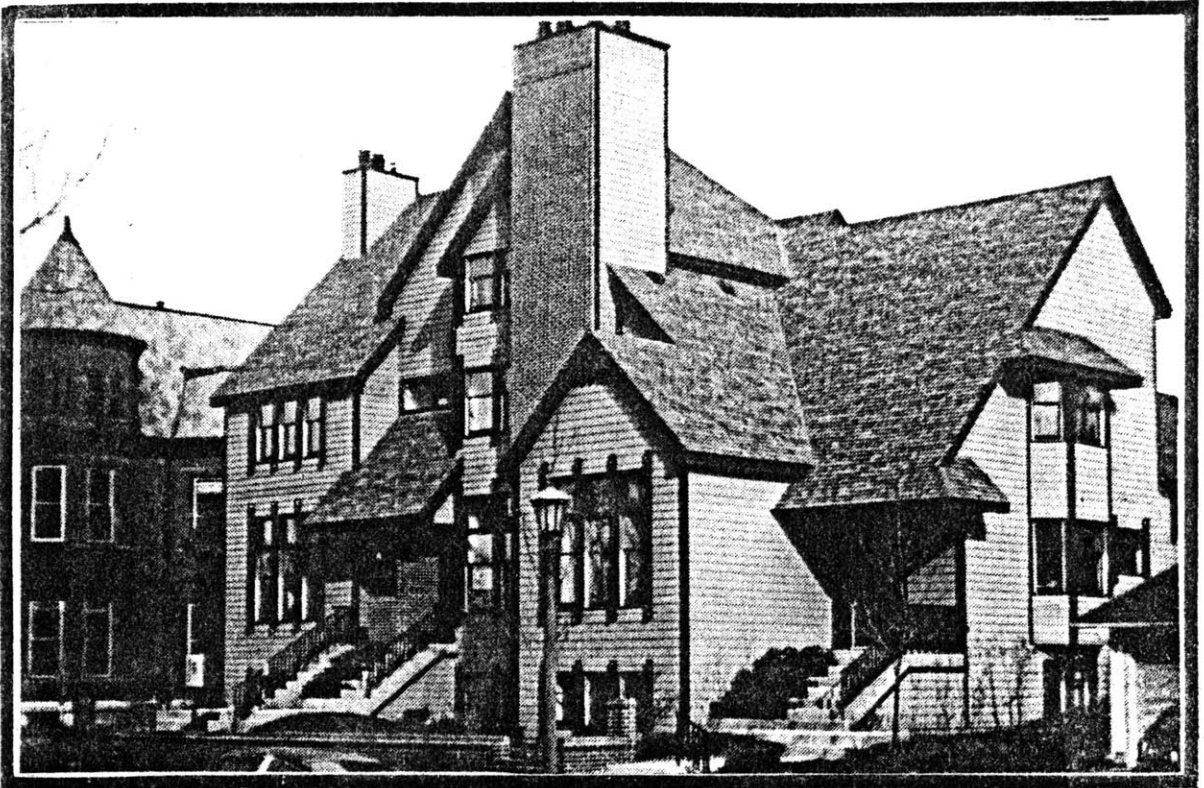

Figure 3-2

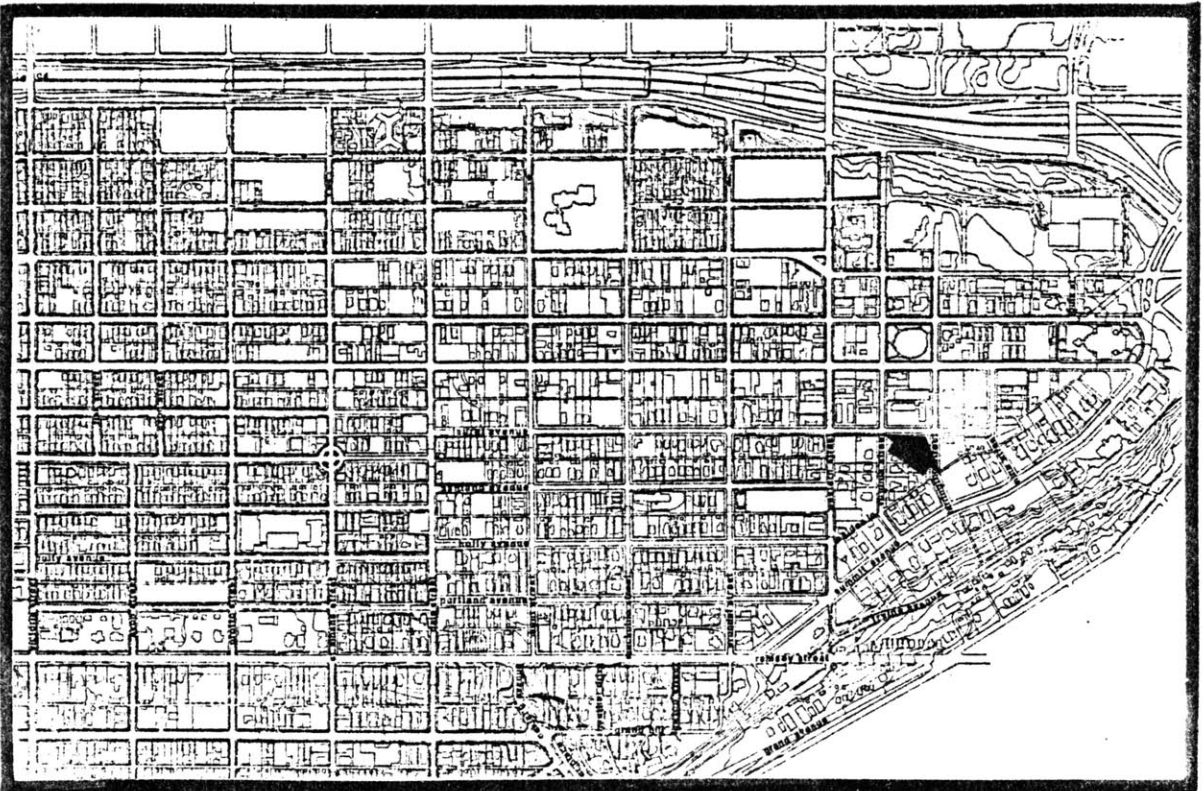

Figure 3-3

walk away, as well as the commanding view of the city and the Mississippi River valley from the southern bluffs of the neighborhood. With gentrification came reinvestment and appreciating land values, and the displacement of the poorer classes to the northern side of the freeway and to the ethnic working class communities of West St. Paul. At this time the land in the Model Cities area adjacent to the Ramsey Hill district looked attractive to Bob Engstrom, a developer who had spent the previous ten years building suburban townhouses and condominiums.

Engstrom saw development potential in the empty block on the corner of Farrington Street and Nina Avenue, on which were several smaller homes and boarded-up mansions (see Figure 3-2). He obtained development rights to the land from the St. Paul Housing Authority and prepared his development strategy. He noted that several blocks away a developer had built condominiums on the land of a sub-divided estate overlooking the Mississippi River Valley. The developer's failure to build a pitched roof on the condominiums to resemble other area homes led to a lawsuit by local residents who were seeking state historical district status for the community.

Engstrom, a sensitive designer and realistic developer, decided to copy the qualities of the neighborhood mansions in his development rather than build the townhouse models he had used in suburbia. Consequently, he planned his townhouses to reflect the single-family mansion character of the existing neighborhood. In addition, he planned a row house condominium project that maintained the quality of the linear brick row houses that occurred occasionally throughout

the neighborhood. In part of his development he recycled existing smaller houses and relocated "blighted" larger homes from other neighborhoods to match the existing housing characteristics of the area.

In the house on 506 Farrington Street (see Figure 3-2), he built three rowhouses within the envelope of a single-family detached mansion. He carefully matched the nearby materials, colors, setbacks, and roof angles of the houses on the adjacent blocks. In addition, he repeated the vehicle traffic pattern on his site plan so that it resembled the alleys of the neighborhood.

Recently the three condominiums were sold and Engstrom moved to adjacent building sites to continue his development. As he progresses, his new condominium, infill, rehab approach blends well with the newly formulated design guidelines adapted by the Ramsey Hill Historical District.

Throughout the project, Engstrom worked carefully with the community leaders so that there was little misunderstanding about his intentions. By building the condominiums as row houses within a single structure, he copied the character of the single family mansions on the adjacent properties. Only the chimney with the brick facade reveals the age of his building.

A discerning eye would also see that the New England salt box roof is not an authentic addition to the neighborhood. The Block City model was preserved with this intervention. The compatibility of context and intervention came from the influence of Level 4 desires on Level 5 development. These qualities are seen in the summary

pathway diagram which shows the similarity of context and intervention. A development based on the Block City model was used in a Block City context.

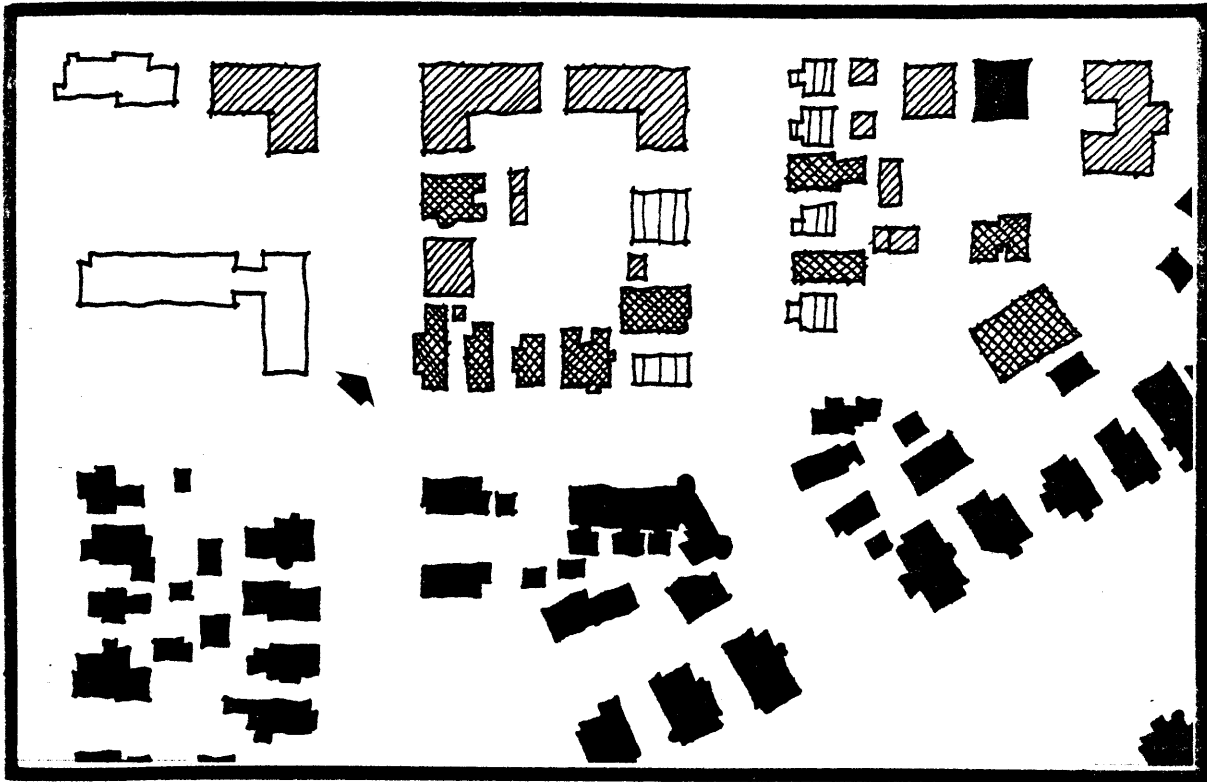

Figure 3-4

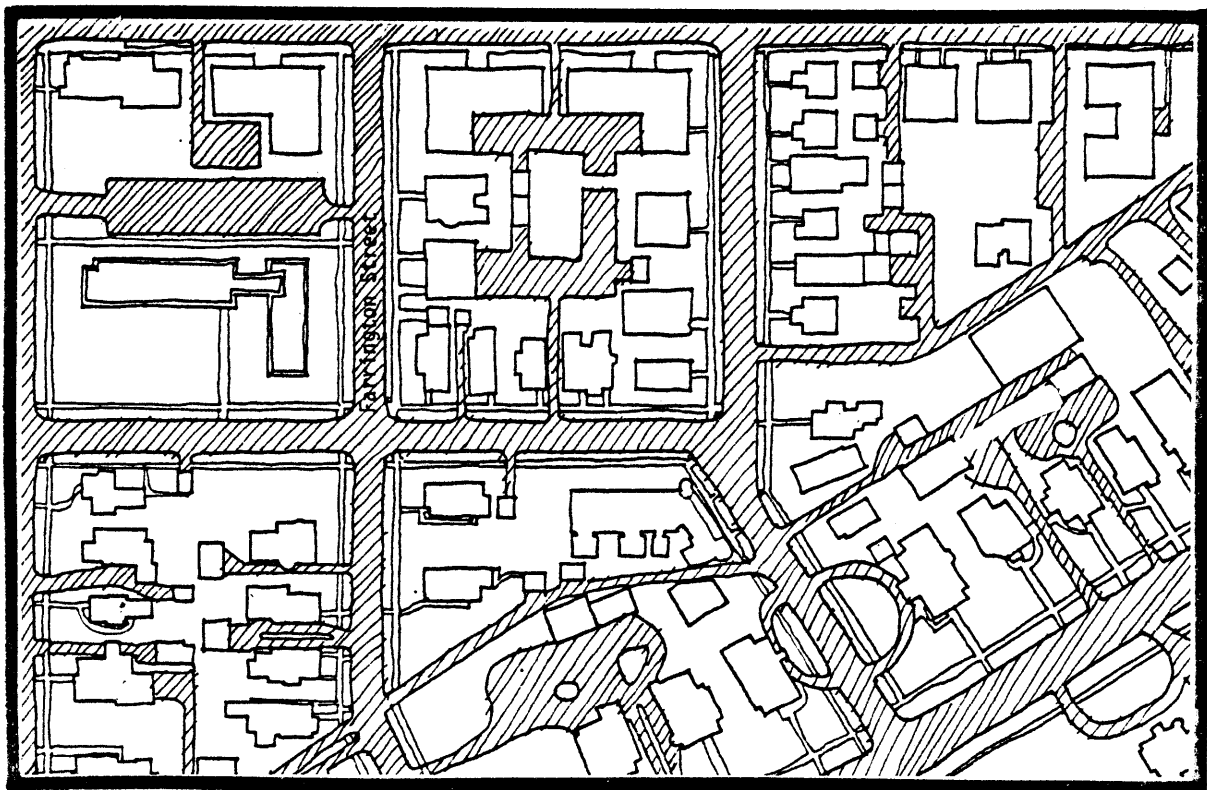

Figure 3-5

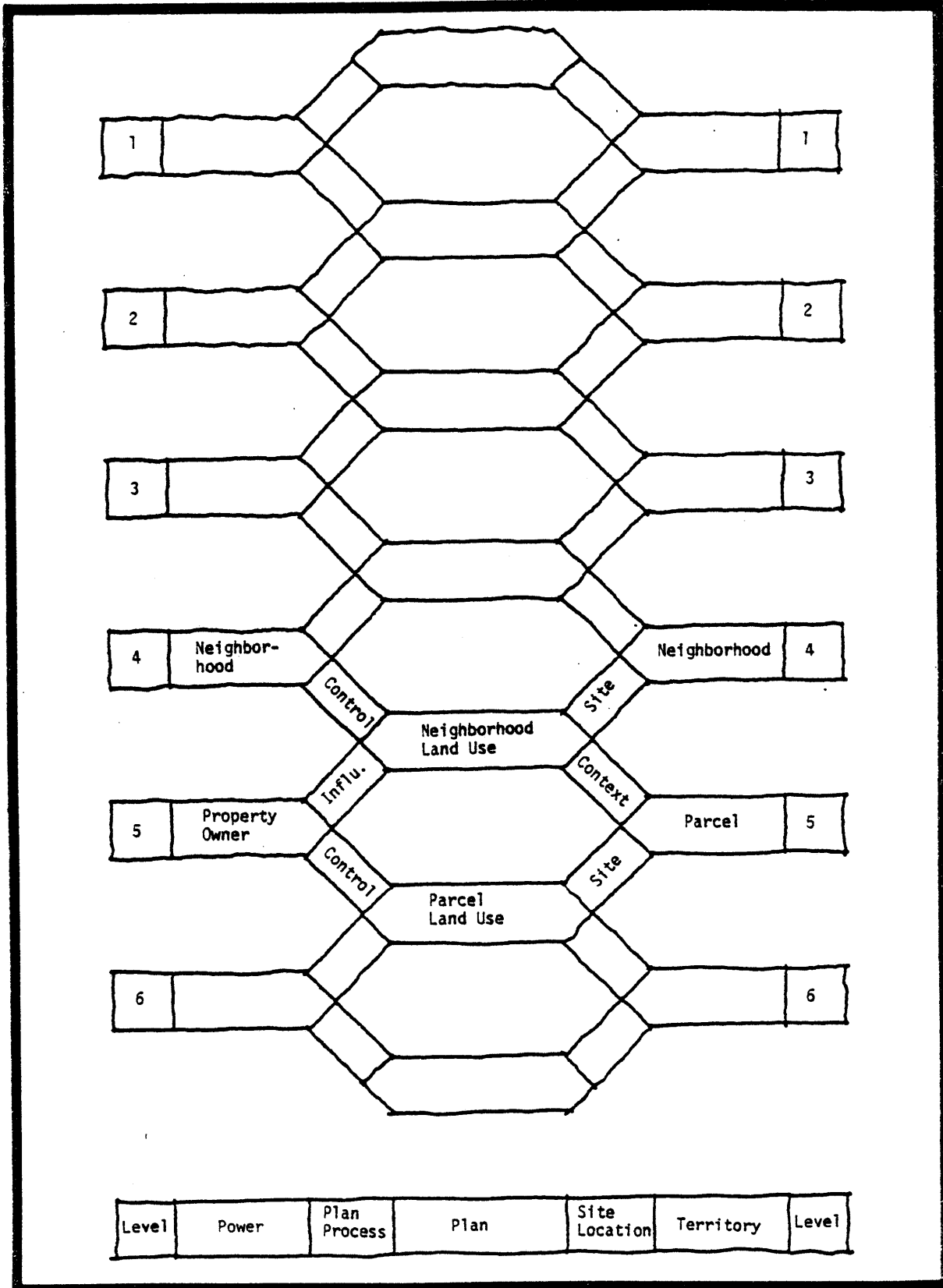

Figure 3-6

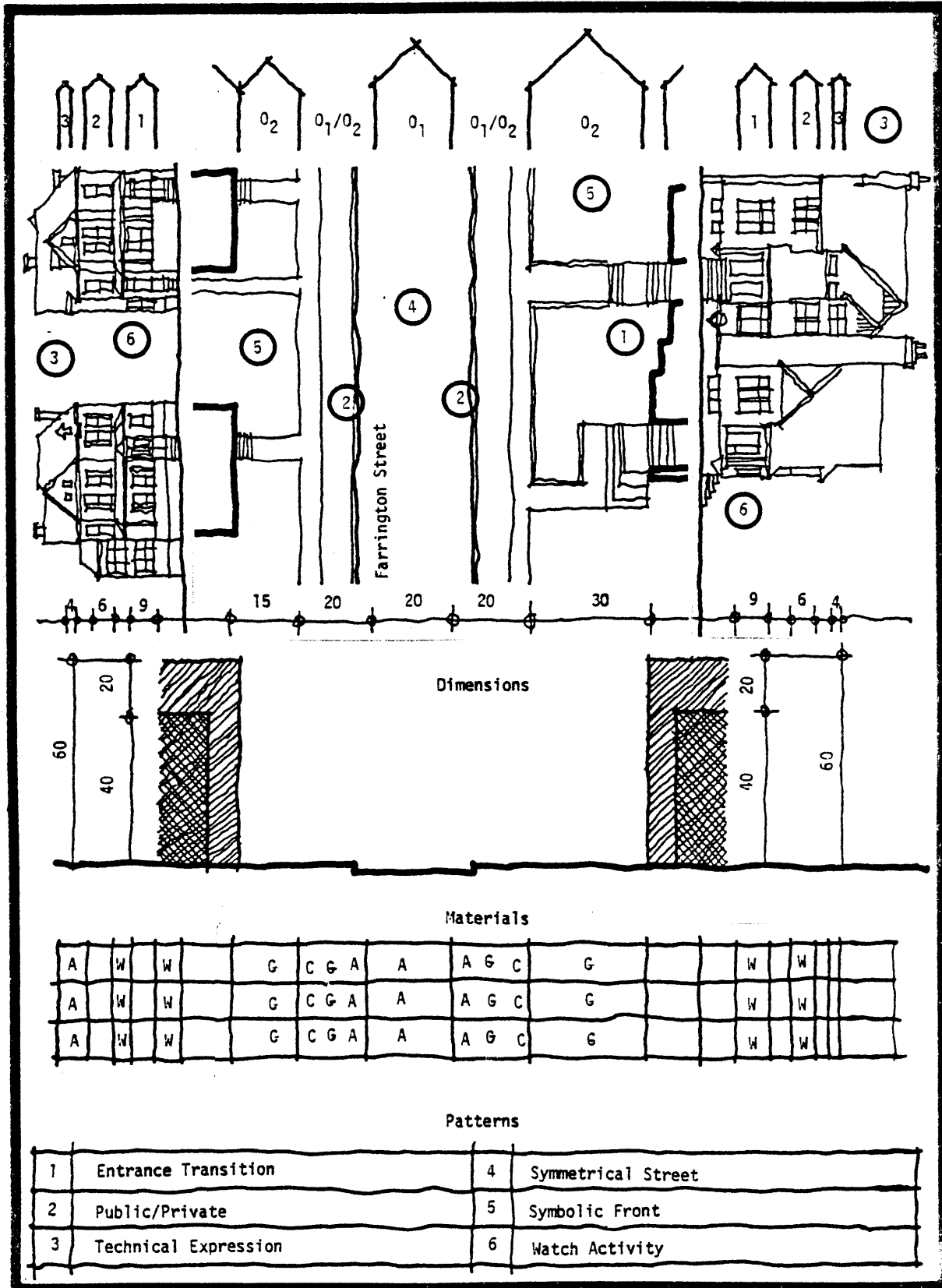

Figure 3-7

Exeter Towers, Back Bay, Boston, Massachusetts

Back Bay, Boston, is the prototypical district described by Kevin Lynch in his book Image of the City. Here a great many row houses were rapidly built between 1860 and 1880 from landfill on the Charles River salt marshes. The Back Bay was the extension of the townhouses of Beacon Hill that served the city's aristocracy and bourgeoisie before the advent of the street car encouraged their exodus in the early 1900's. In the years of its development, the Back Bay had a remarkable consistency based on structural similarity, material consistency, detail similarity, and orthogonal street organization.

In addition, a strong sense of rhythm came from the numerous developers who built one or two row houses at a time, each with a similar floor plan but with slightly different details. The fragmented ownership patterns have left the area with a wonderful variety among row house facades. As a district it had strong boundaries: Fenway Park to the west, Storrow Drive to the north, Boylston Street to the south, and the Boston Common to the east. The area's small size and its isolation by strong surrounding boundaries enhanced its sense of district (see Figure 3-8).

The row house structure with its relatively narrow structural bay has allowed the district to absorb a variety of user groups and dwelling types. In the early twentieth century the row houses were divided into smaller apartments. This change recently reversed: the row houses have been reconverted to townhouses and condominiums in the same fashion of the original design. The beauty of the row house module is its ability to accept a variety of change internally

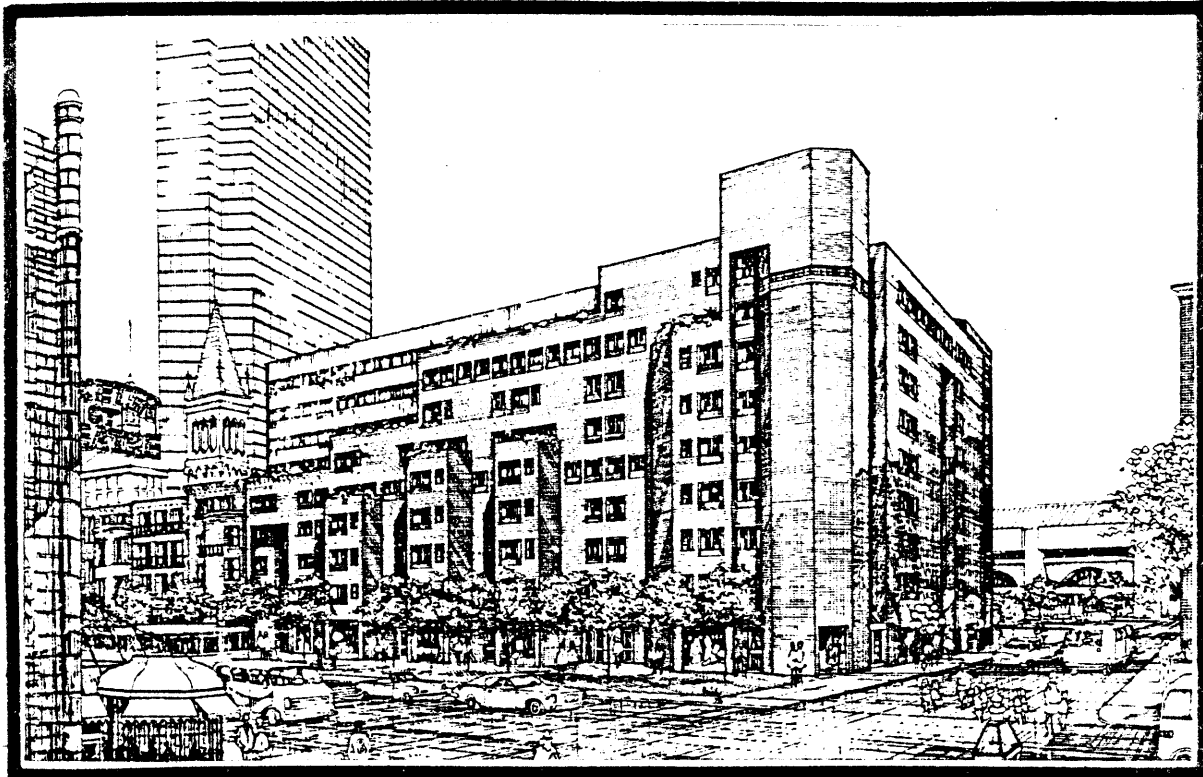

Figure 3-8

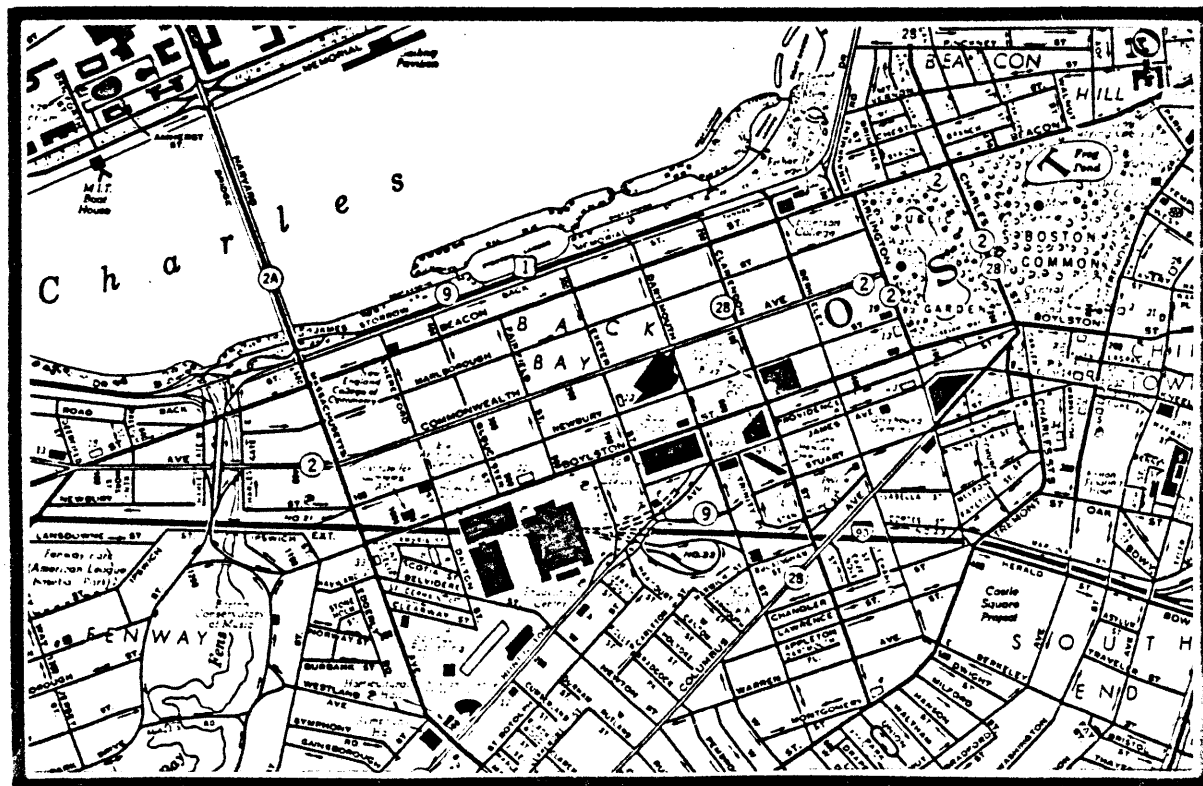

Figure 3-9

without exterior differentiation. Typically a townhouse stands beside the five unit apartment building, each with its own entrance and identical exterior appearance.

The ample gridiron street pattern with generous 01/02 margins and transitional 02 zones, many of which have been excavated for lower level shops, has created a rich pedestrian character, producing one of the country's best urban walking districts. Charles Moore, the noted American architect, comments first of all obliquely about thematic and non-thematic aspects of environment, and then about the qualities of urban pedestrian spaces in Body, Memory, and Architecture:

Curiously, the wholesale inhuman, "social" manipulation of urban form by twentieth-century architectural and planning offices has put a disproportionate emphasis on originality, on the unique. Rather, we believe, the design of the environment is a choreography of the familiar and surprising, in which the familiar has the central role, and a major function of the surprising is to render the familiar afresh. The most satisfying places we know are not the architectural zoos, but places like Boston's Back Bay, or the canals of Amsterdam, or Georgian cities across the Western world, where a broad area of human agreement allows the merest nuance of difference to show up as an individual act of caring and establishes an urban scale against which civic acts of vigor and congenial daring might leap into the public memory.

The great quality, then, in the Back Bay is the dialog of the observer with the clues, the acts, and the signs of activity of people who have lived there in the past, the present, and the future. In a sense it is a place of many human signatures, richly evident as one walks along the 01/02 margin. It is a richness that comes from the acts of many dwellers which, in some cases, led to formal change, in other cases simply to the respectful maintenance of the existing. An architect cannot create this; he can only set a stage for it to happen. Back Bay is a universal, timeless pattern.

Because of the area's unique qualities, it was declared an Historical District by the Massachusetts State Legislature in 1968 during the height of the urban renewal era. At one time the Back Bay was to become a renewal area in Ed Logue's original plans, but the neighborhood, after reviewing a planning study reflecting possible changes, said no. It was the only neighborhood that had the power to refuse federally subsidized change.

The 1968 Historical District classification requires any new construction or major building modifications to be reviewed by a number of legally sanctioned committees, including the Back Bay Historical Commission, the Massachusetts Historical Commission, the Boston Redevelopment Authority, and ultimately the Mayor. The Mayor also allows the BRA to negotiate for a 121A tax agreement, which allows a developer a limited profit on earnings in exchange for an excise tax in lieu of property tax. Without a 121A agreement, the high costs of land and the height and bulk restrictions placed on development by the requirements of the historic district, make new development impossible.

Our study site comes with the demolition of the Copley Methodist/Episcopal Church at the corner of Exeter and Newbury Street. Temporarily, the vacant land provided needed parking space for the residents of Back Bay and the commercial shoppers on Newbury Street. But the parcel was too valuable for parking use.

When the MB group, a Boston development firm, proposed Exeter towers, they had put together a very reasonable mixed use package. It proposed the replication of the existing uses on Newbury Street

with first floor commercial and offices, nine stories of luxury apartments above, and subsurface garage parking below. The high land values caused the project to more than double the density from the existing 55 du/acre to 122 du/acre.

The architects did this by providing largely one bedroom apartments, as well as by massing the building along Newbury Street to match the adjacent cornice line and brick cladding. Above this four-story height they set back the remaining five stories, and used a metal wall rather than brick. As the building approached Exeter Street, it rose to nine stories as the staggered setback disappeared. This nine story brick-clad facade matched the other buildings along Exeter Street. Fortunately the developers were able to reduce the parking ratio to .5 and provide only 48 garaged parking stalls instead of the normal 96 required for the 96 units (12 units per floor), (see Figure 3-7).

Not all the residents in the Back Bay community were happy with the project. Although approved by the Back Bay Businessmen's Association, it was not approved by the Back Bay Neighborhood Association, which wanted to attract more families to the Back Bay. They were justifiably suspicious of a largely "singles" apartment building with 90% one bedroom units being across the street from the Exeter Theater and Firday's, a singles bar and restaurant. The group fought unsuccessfully to block the award of the 121A tax agreement. The project is presently under construction.

The site plan (see Figure 3-10) and the figure-ground plan (see Figure 3-9) show the efforts by the developer to pattern the

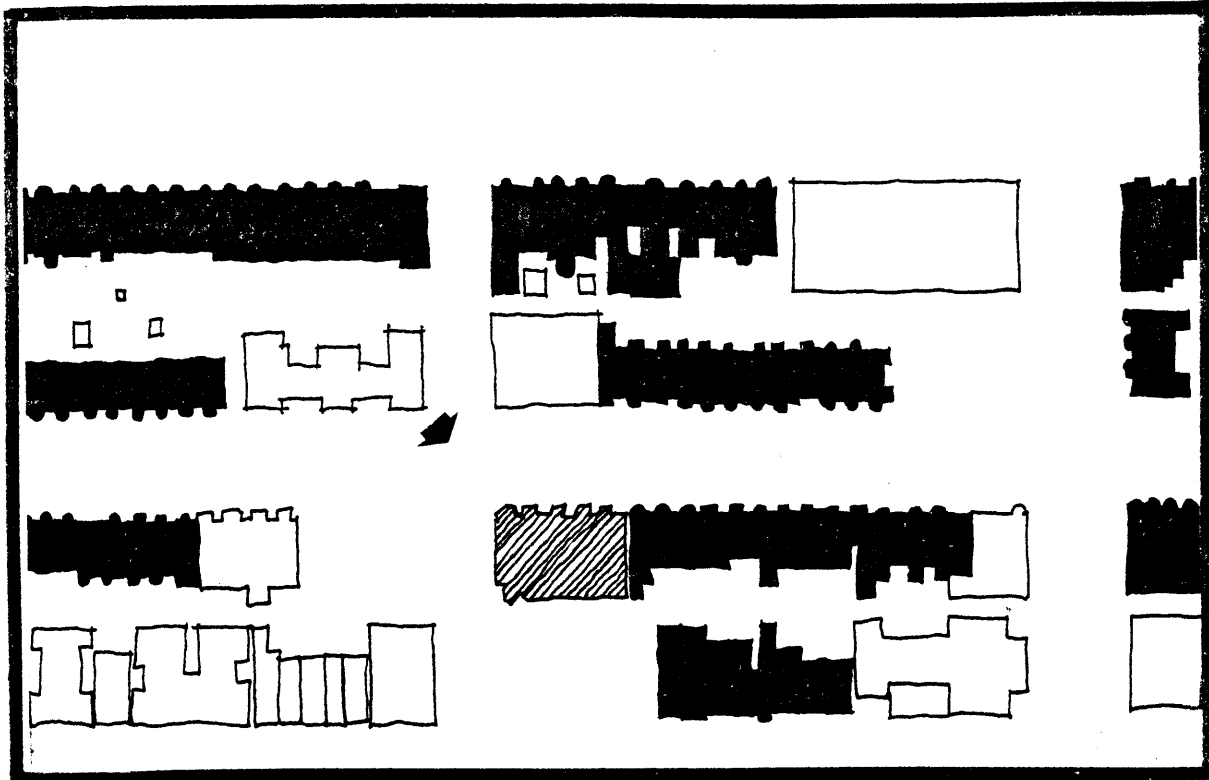

Figure 3-10

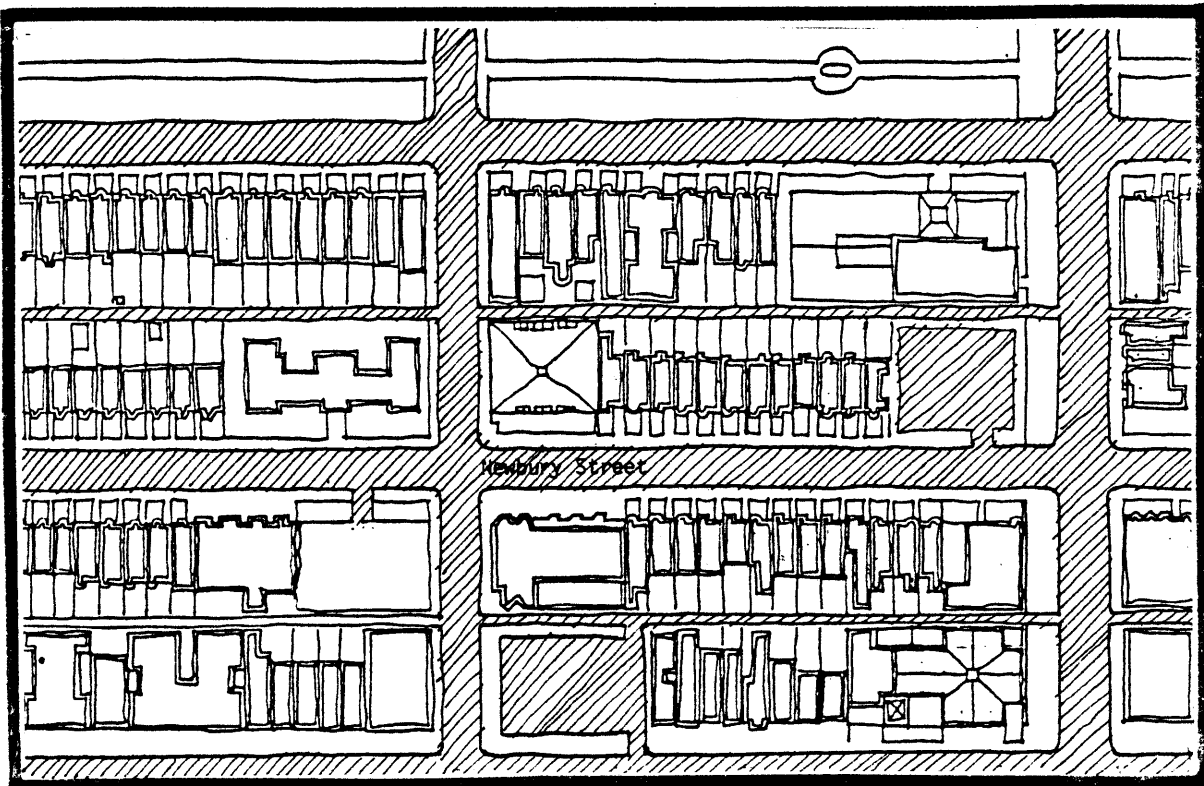

Figure 3-11

development after existing context. Examining the level diagram one can see that this contextual compatibility came from a Level 5 response to the formal design review procedures of Levels 4,3, and 2 (see Figure 3-11). The summary pathway diagrams (see Figures 3-12 and 3-13) show the intervention's success with the existing context, a success that dispels the myth that high density housing cannot respect the existing Block City context and must necessarily follow the Radiant City model.

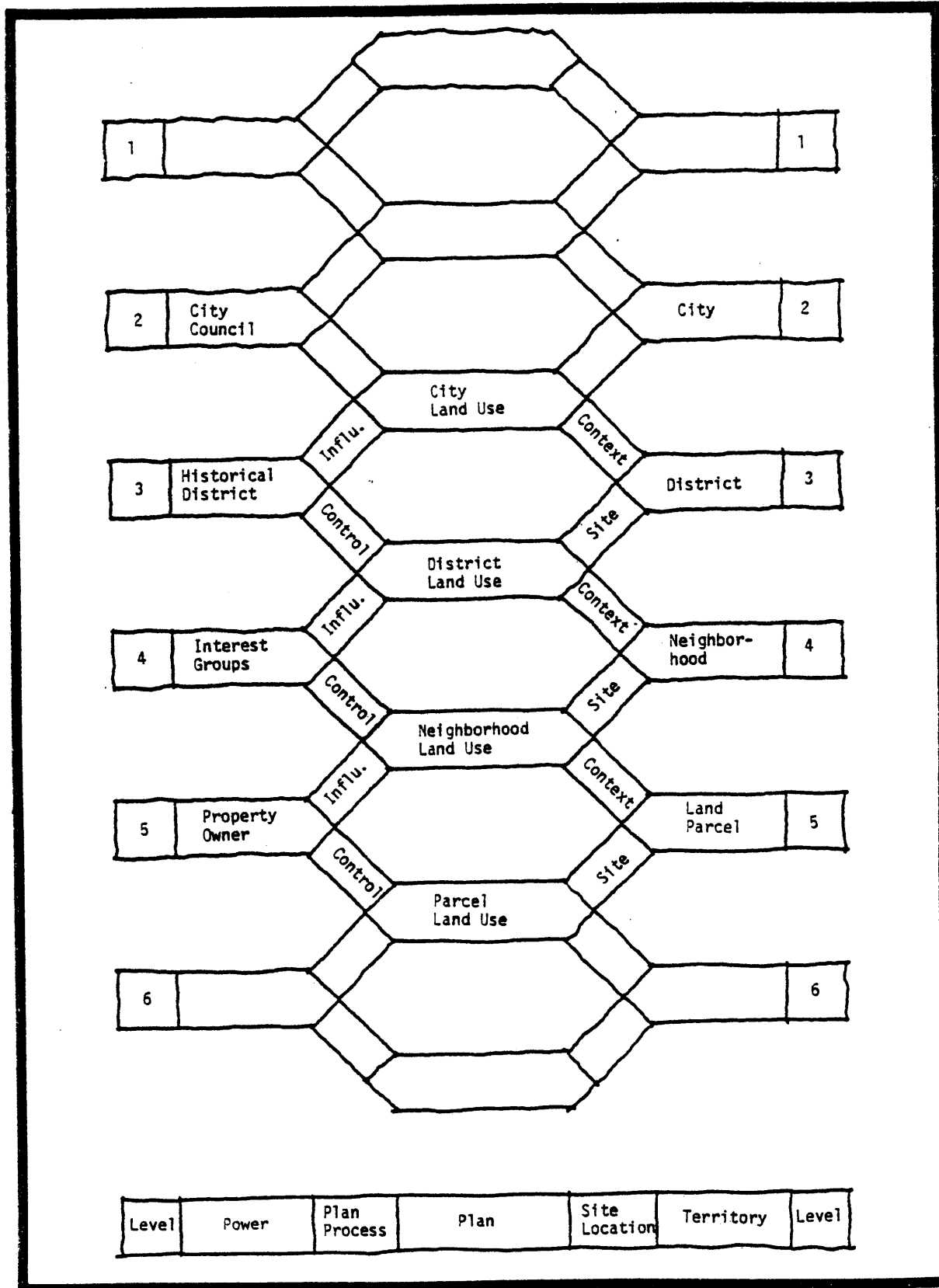

Figure 3-12

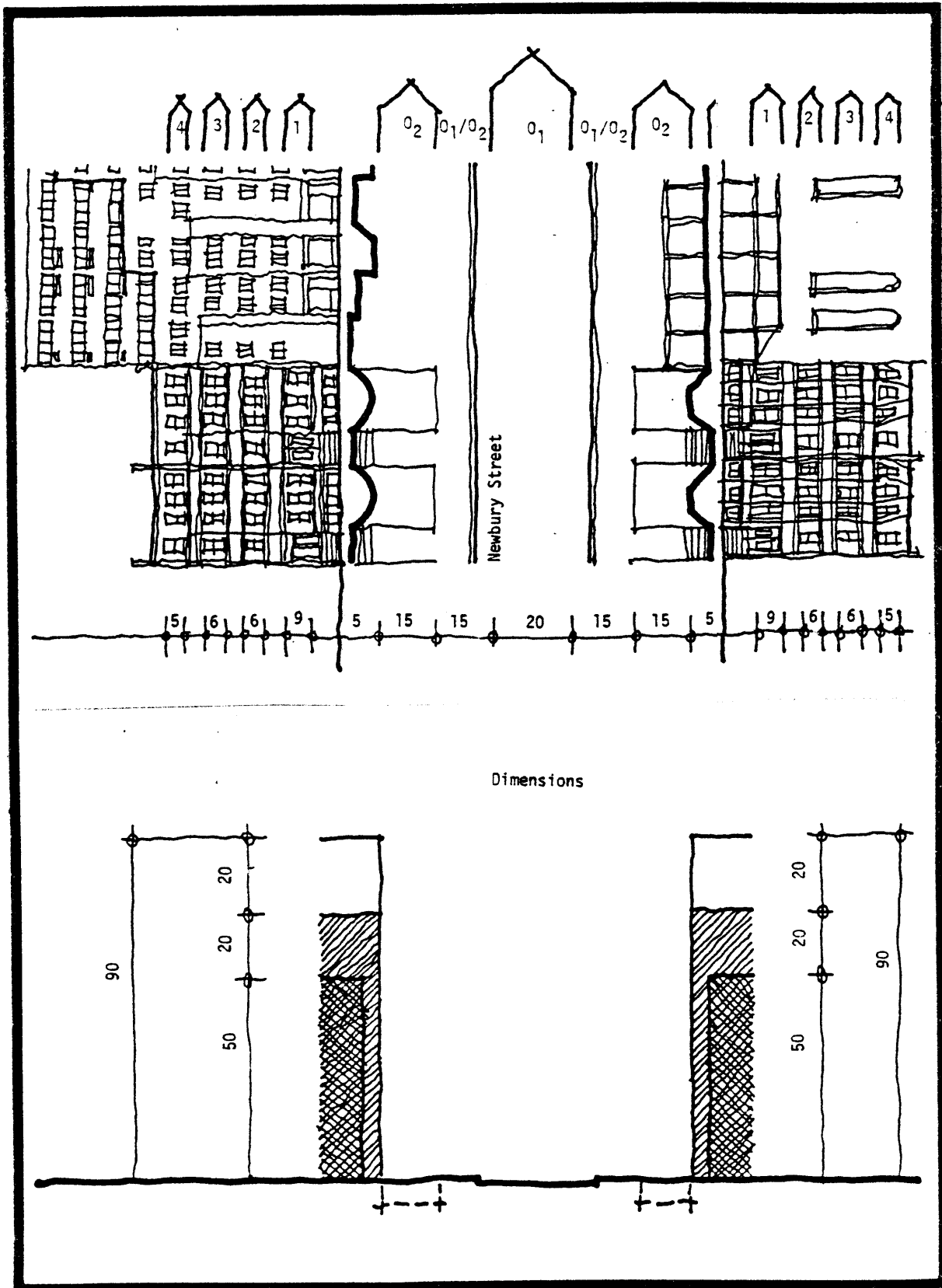

Figure 3-13

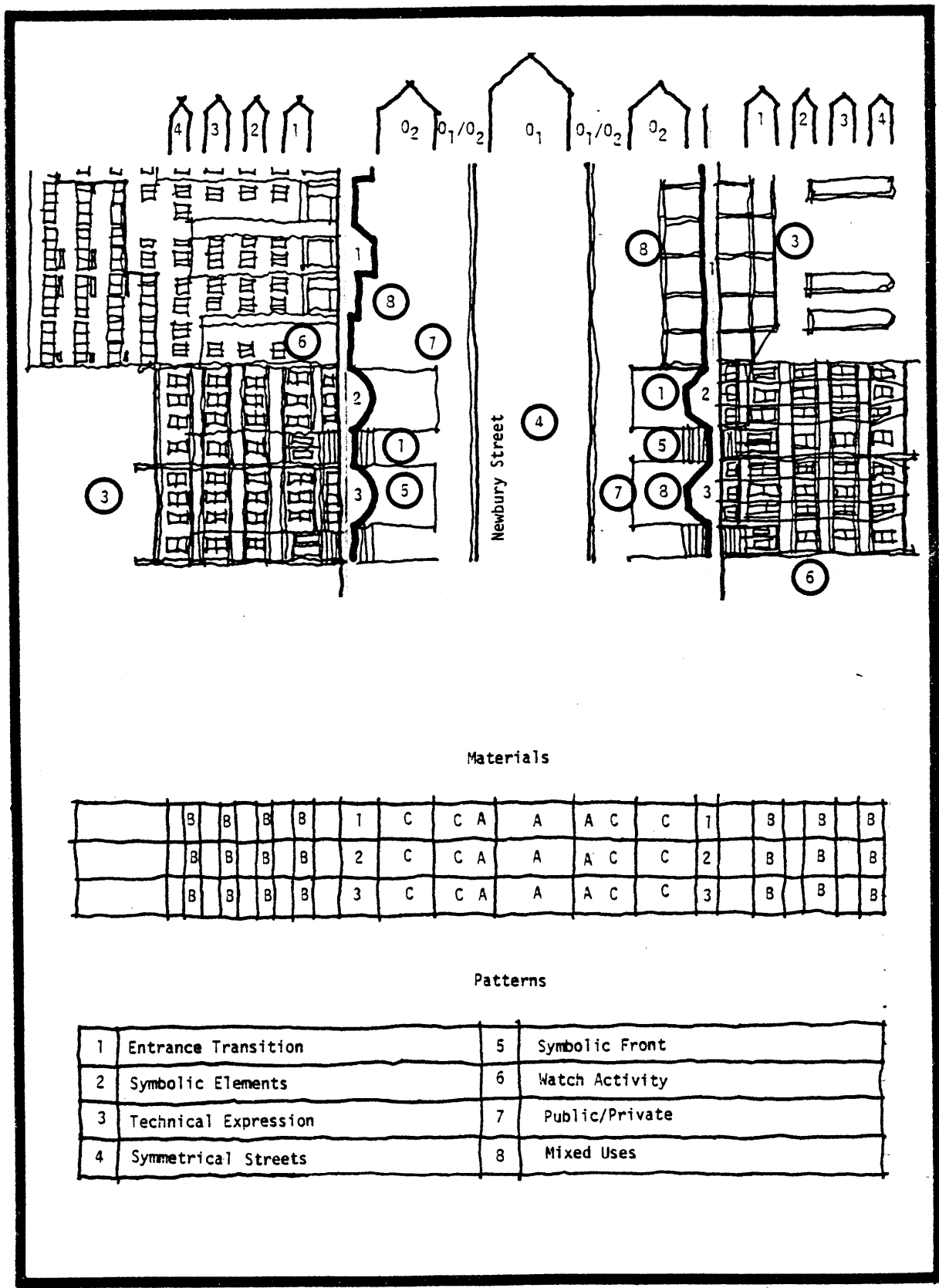

Figure 3-14

Town Oaks, Powderhorn Neighborhood, Minneapolis, Minnesota

Town Oaks was a new townhouse project built on vacant church land in a south Minneapolis neighborhood in radical transition. It is located east of the major north-south freeway that divides the largely mixed neighborhood to the east from the white neighborhood to the west (see Figure 3-15). The townhouses were turned inward from their context because the developer, Metram, Inc., desired to attract suburban whites to the short commuting distances of inner city living, to combat the above average crime rate in a largely black neighborhood, and to build at a higher density (14 du/acre) than the 6 du/acre of the adjacent areas because of high land costs.

To execute the project, the developer obtained a PUD zoning approval. This ordinance allowed him to consolidate two city blocks and to build at a density and configuration different from that required by the surrounding single family zoning. In the process of block consolidation, he broke the rhythm of the street modulation and created a superblock.

The site planning in Town Oaks was an effort by the developer to create something unique to the area in order to appeal to a specific market. The internally oriented development makes it more exclusive, particularly with its private common space playground. This playground and the surrounding green spaces are, like the uniformly earth-toned buildings, maintained by the Home Owners' Association. The monochromatic buildings contrast greatly with the varied stucco, wood, and brick buildings across the streets (see Figure 3-14). The project turns away from the pattern of the existing streets by having front entrances open on parking cul-de-sacs, which are the vehicular



Figure 3-15



Figure 3-16

entrances from the street, and leaving many of the units with their back sides facing the street. This is a reversal of the community pattern (see Figures 3-15 and 3-16).

Upon examination, one could see that even with the PUD zoning and the higher densities, the existing street relationships could be retained. Consequently, as one walks along the sidewalk, he notices an ambiguous edge along the O2 zone where nobody is in control. One is not sure from the given clues how to behave. It is a critical problem of territorial ambiguity described in Oscar Newman's book Defensible Space. Newman suggests that any common territory without explicit overlook or distinctive demarcation between public and private space is a potential crime source.²

Apart from the superblock site planning principles, however, the townhouses are well designed and spacious. For their time they were reasonably priced and sold quickly. The racial composition of the new owners was 90% white and 10% black, in contrast with the 30% white and 70% black surrounding neighborhood. In addition, professional and management occupations constituted 70% of the development's occupants as opposed to 25% of those in the neighborhood. Metram, Inc., was successful in its gentrification effort. In 1976 the project won an urban design and planning award in the Lived-In Environment category from Design and Environment magazine.³

The site plan and the built open space plan show the impact of the Superblock intervention (see Figures 3-16 and 3-17). The level diagram shows the project was the result of two levels of involvement, those of Level 5 by the developer and his architect and by Level 2, the City Council, which reviews PUD zoning applications. There was no involvement of actors at Levels 3 and 4 (see Figure 3-18). The summary pathway diagrams show the contrasts created by this Garden City/Superblock model on the existing Block City model context (see Figure 3-19).

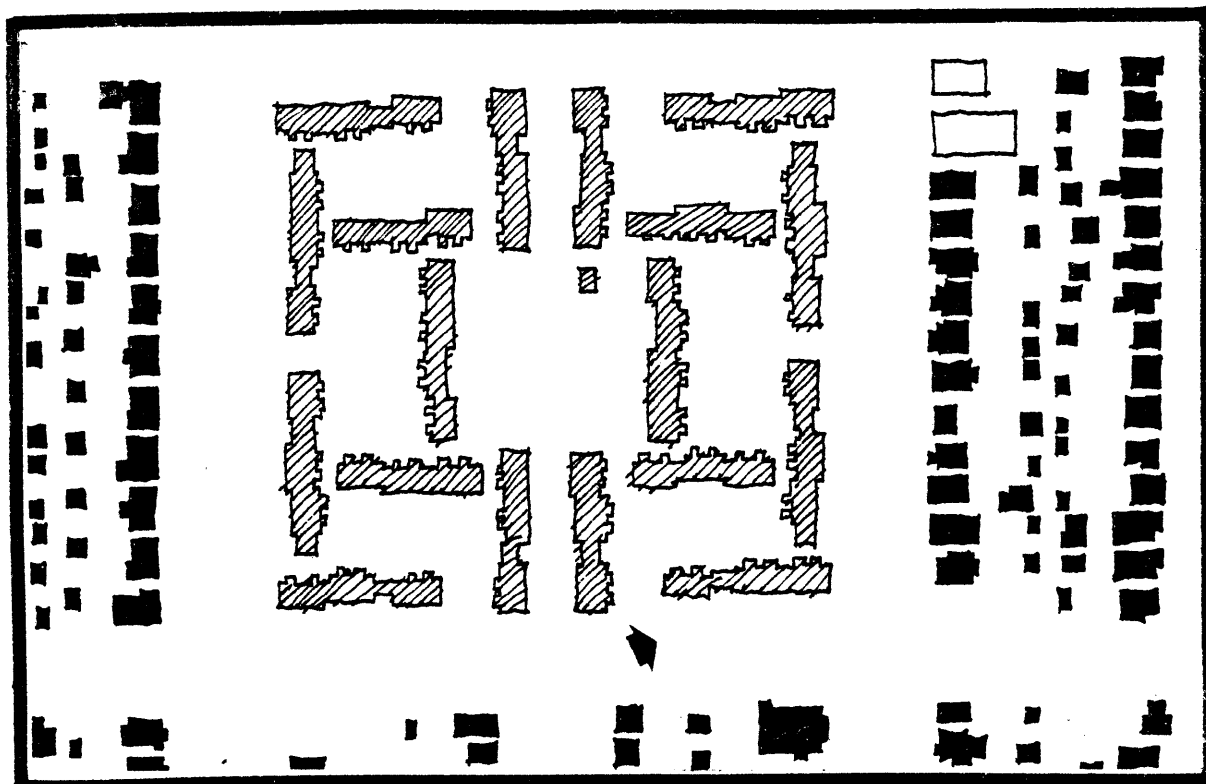

Figure 3-17

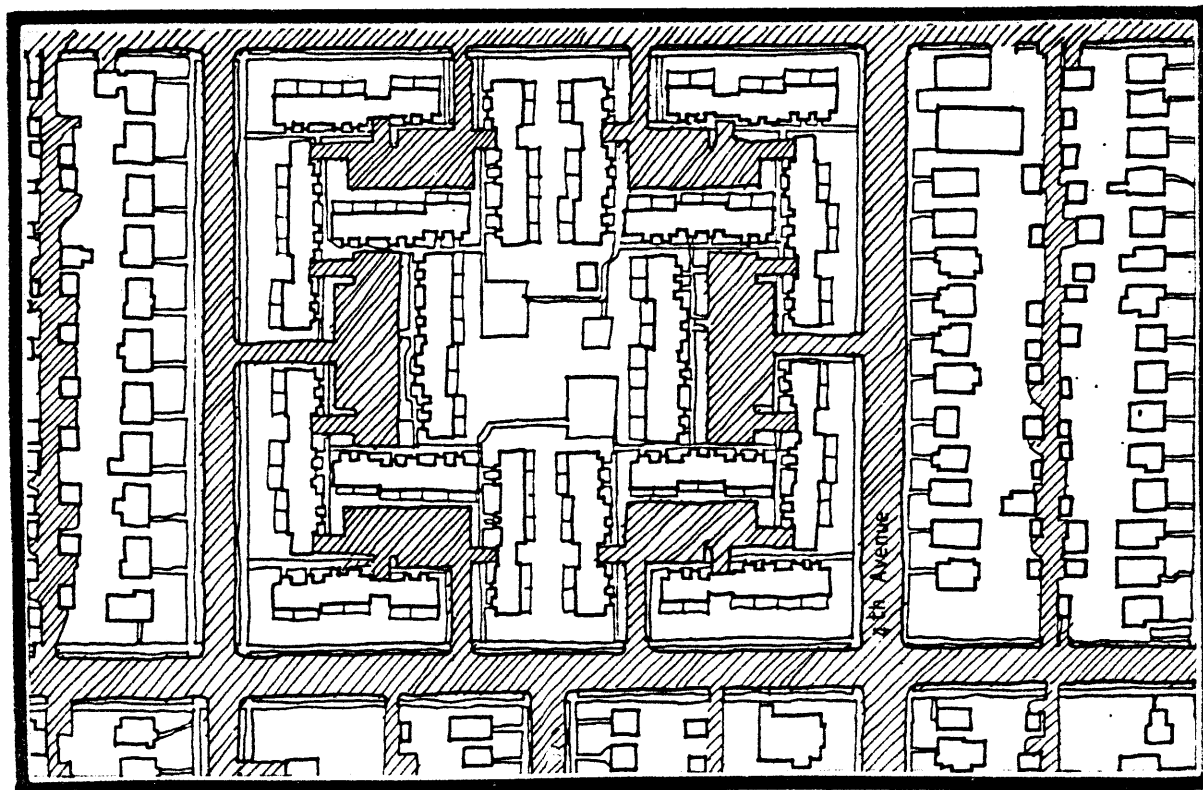

Figure 3-18

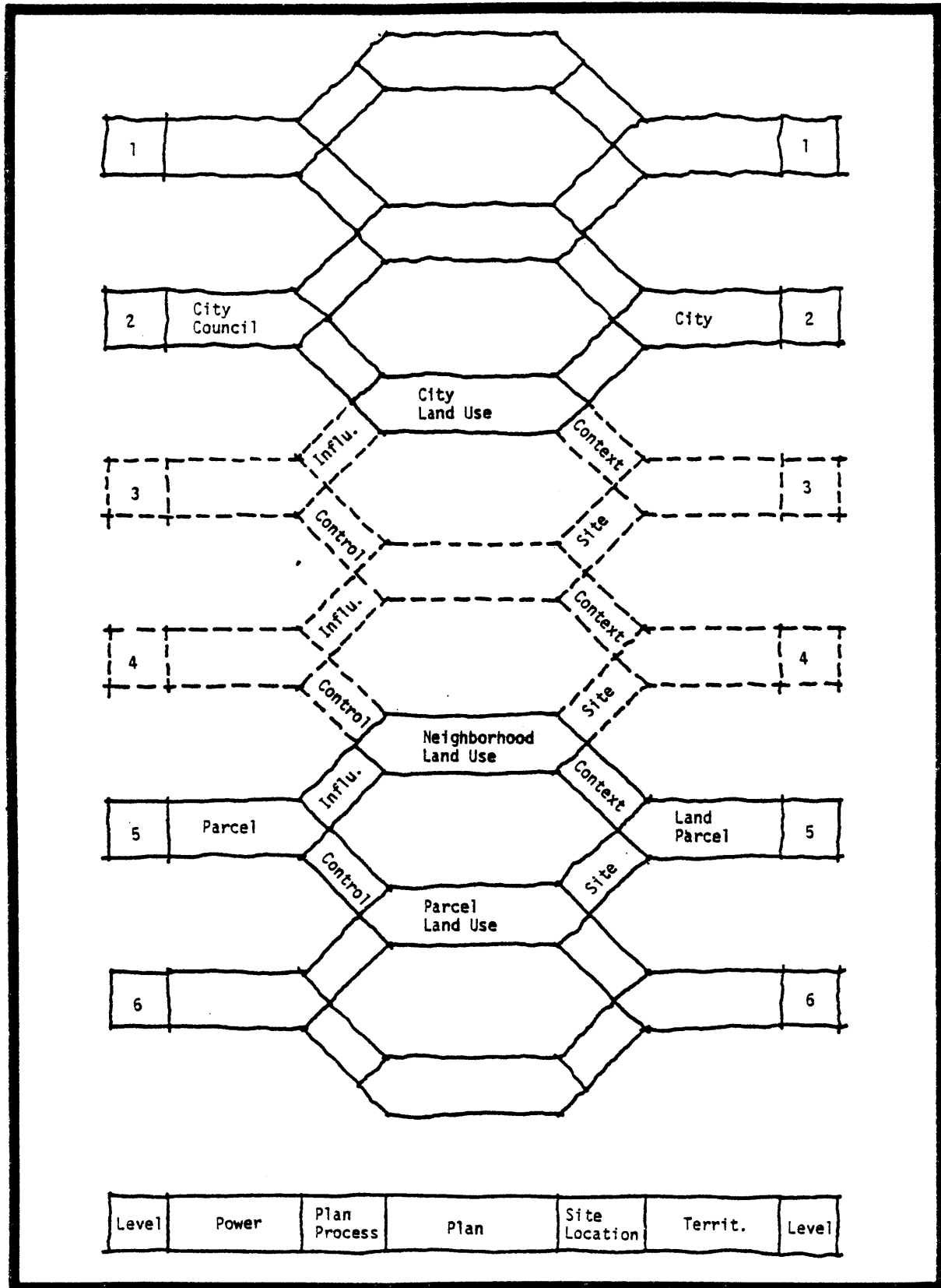

Figure 3-19

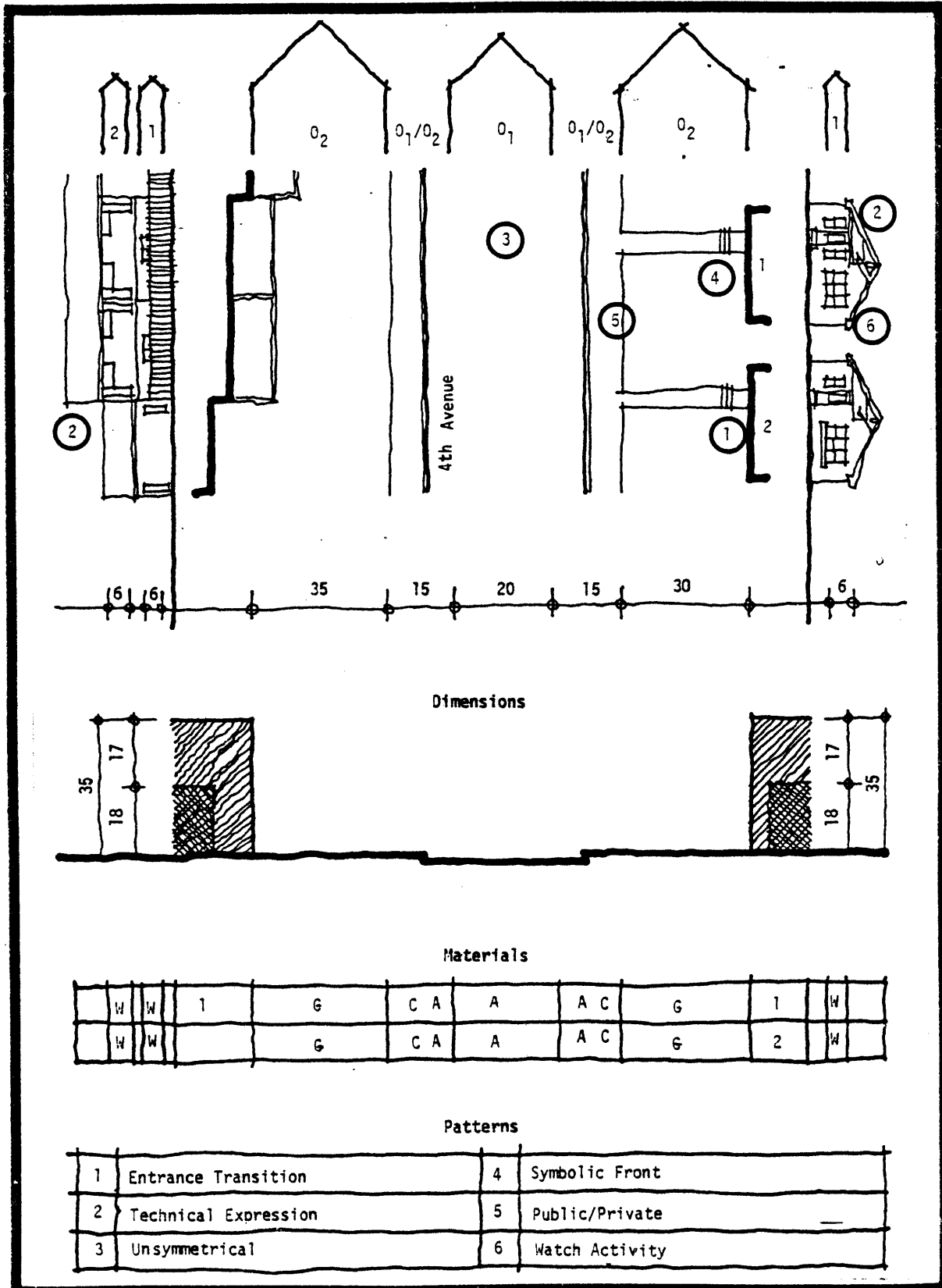

Figure 3-20

Villa Victoria, South End, Boston

Villa Victoria is one of the most publicized examples of community development in the country (see Figure 3-20). Located in Boston's South End, it is the result of the Puerto Rican community's long struggle to find a permanent home in Boston. Its success is the result of years of effort to obtain community-developed housing in the face of threatened eviction by the BRA's urban renewal plan. The result of this conflict allowed the Puerto Rican Community to develop Parcel 19 as a managing general partner in a development syndicate whose equity share would enable it to develop larger land holdings (see Figure 3-21). Presently Villa Victoria consists of 490 dwellings in rehabilitated row houses, newly constructed row houses, and a new mid-rise building for the elderly.

Because of the struggle against the BRA and the community's internal building requirements, the community was not interested in maintaining the image of the surrounding brick row houses. In addition, from a "defensible space" position, the semi-private interior stairs of the existing row houses were potential crime sources.

In organizing their program, the community developers felt it would be better to provide the elderly with a high-rise tower, called Torre Union, which would incorporate shops at its base. This commercial activity, then, would overlook a community centered Plaza Del Sol. It was this plaza that would grow to become a community mall with a subsequent addition to the west. Because of the heavy through traffic, the existing row house streets were considered unsafe for children to play in. To solve this problem, Brookline



Figure 3-21

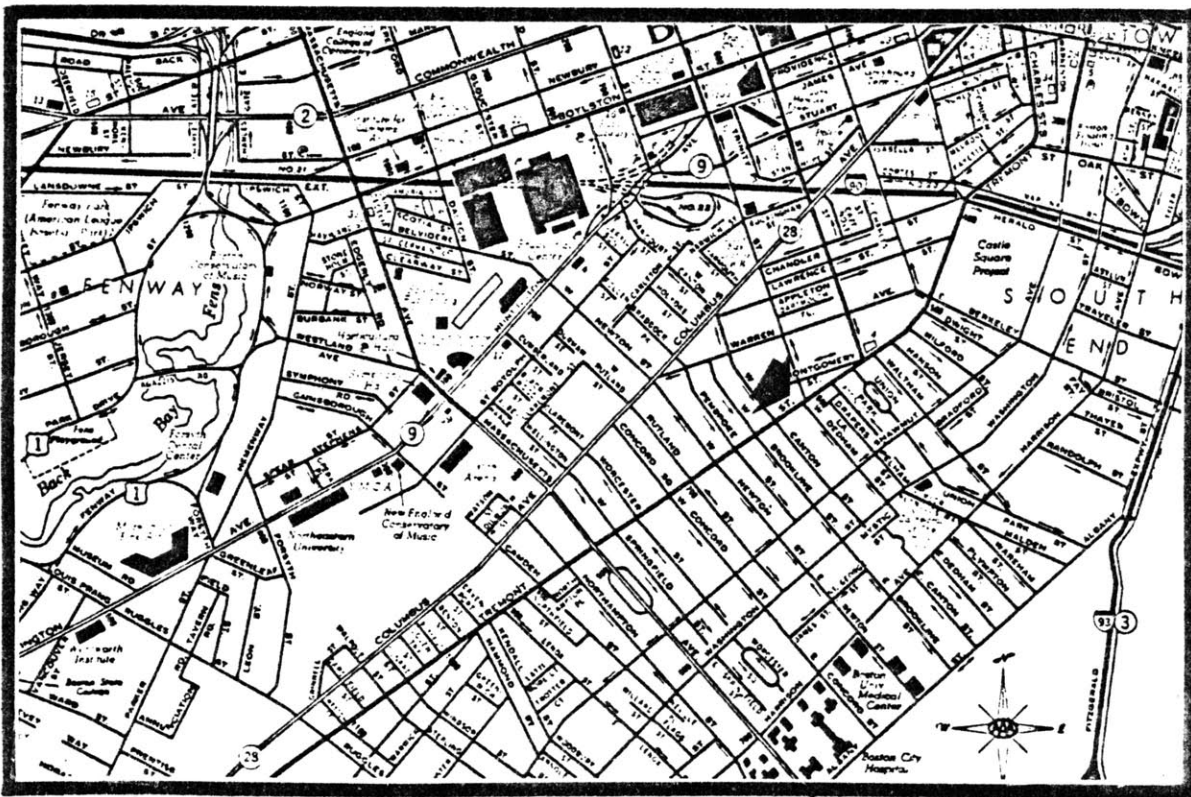

Figure 3-22

and Pembroke Streets were looped together as extensions of Fremont and Shawmut Avenues. The new streets were symbolically renamed Paseo San Juan and Paseo Aquadela. The new streets provide excellent child observation. The two-story row houses were to become duplexes, each with private exterior entrances. The building's colors and roof shapes are reminiscent of the roofs of Puerto Rico.

Consequently, the project takes on its own identity within the brick row house pattern of the South End (see Figure 3-21). The contrast of the project with its context seems to symbolize the achievements of the Puerto Rican community over the renewal efforts of the BRA. It is a fitting and proper contrast. Yet if one looks closely, he sees that the architect was careful in his treatment of the context. The streets retain the same rhythm and pattern of the brick row houses with their front steps; the streets are continuous with the existing streets, and on West Dedham Street and West Newton Street the row houses integrate with the existing street patterns, giving a uniform street frontage. The architect maintained Block City quality even though several blocks were consolidated (see Figure 3-23).

Examining the level diagram one sees that the development activity occurred between Levels 4 and 5 and that a cohesive neighborhood environment resulted that was in character with the South End district in Boston. This continuity is expressed in the summary pathway diagrams (see Figure 3-25). The intervention, based on an attached Block City model, was set in an attached Block City context. Aspects of the intervention such as the long central block with central common space draw on the Garden City model.

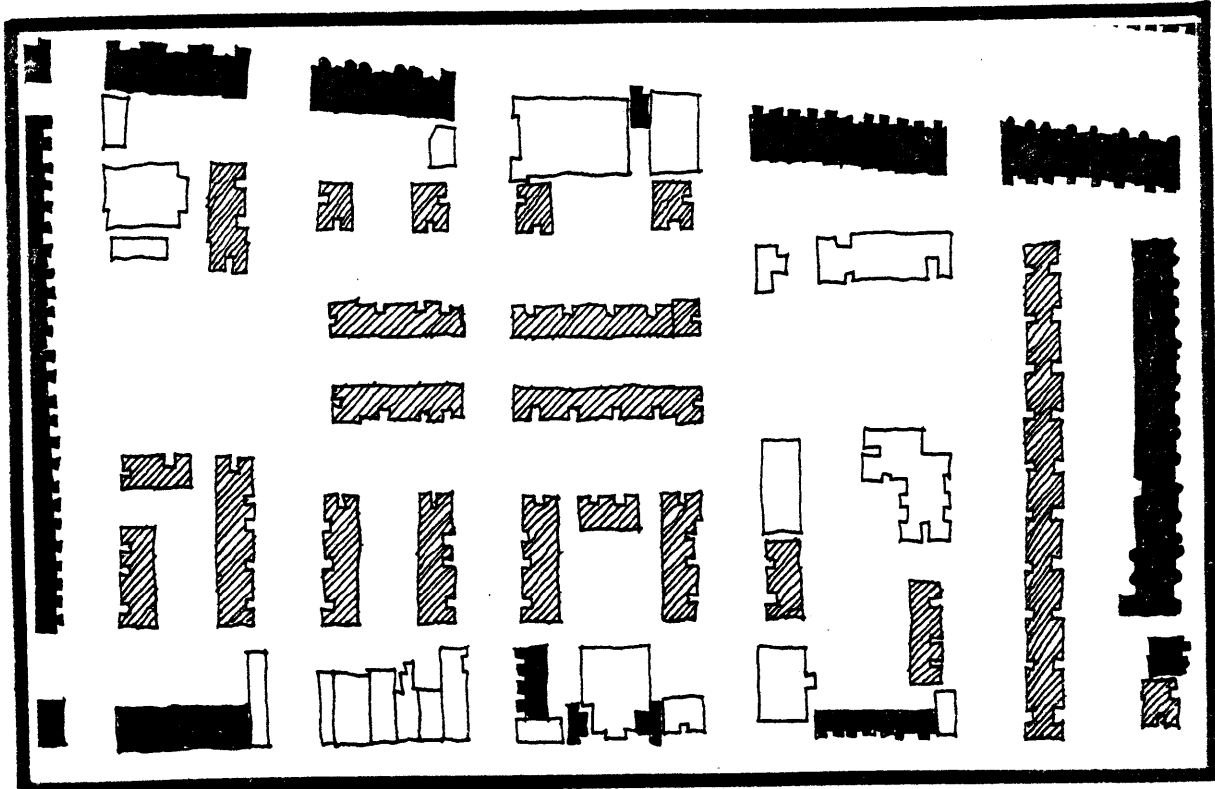

Figure 3-23

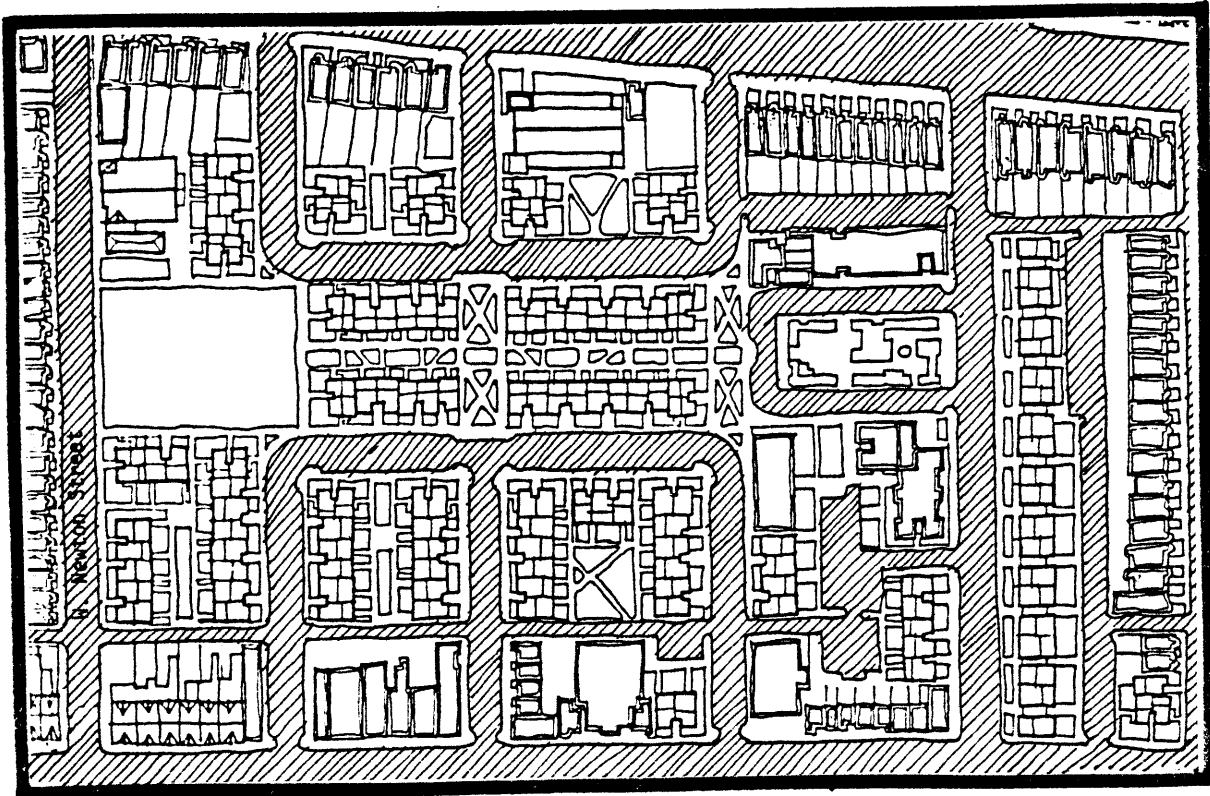

Figure 3-24

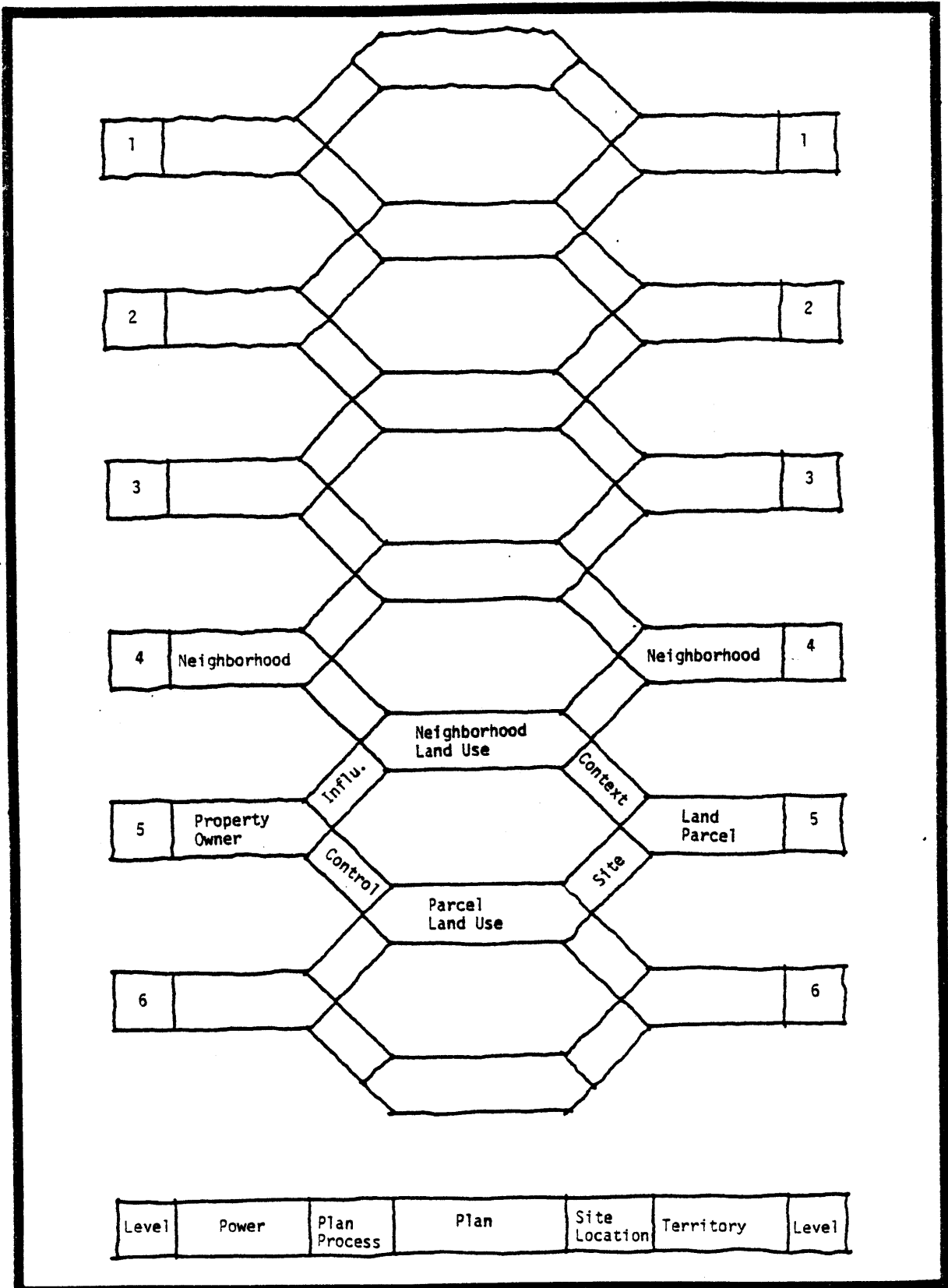

Figure 3-25

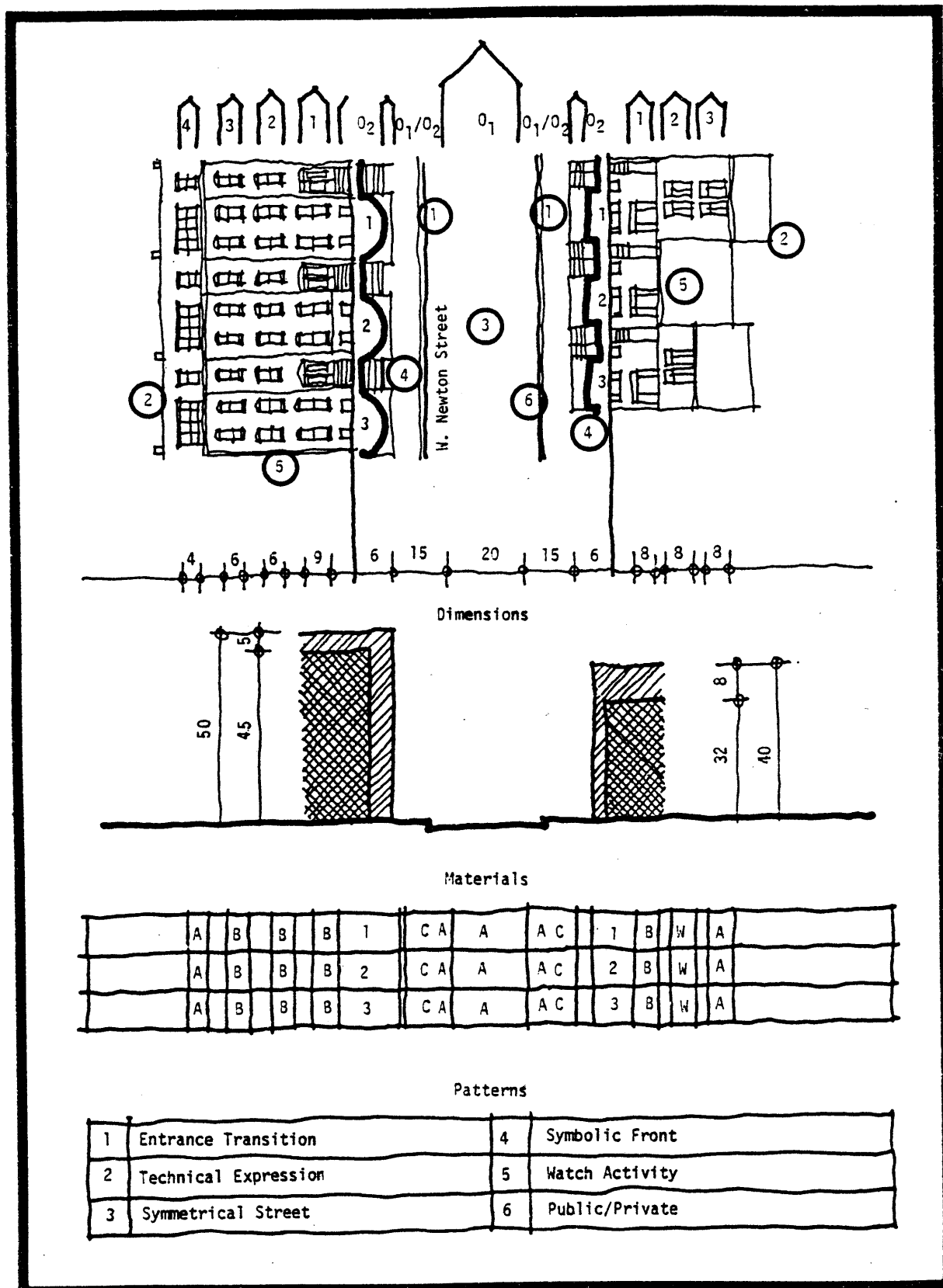

Figure 3-26

Loring Park Development District, Loring Park Neighborhood,
Minneapolis, Minnesota

The Loring Park Tax increment district is a result of a municipal initiative to foster mixed density inner-city development when urban renewal funding began to dwindle in the early 70's (see Figure 3-26). To provide additional funds for urban redevelopment, the city of Minneapolis sponsored a bill in the legislature to foster municipal tax increment financing. The bill, based on a California model, would permit municipalities to issue general obligation bonds with legal limit to finance urban redevelopment. The bill became law in 1971.

The Loring Park Development District was created from this bill and became another effort by the city to attract middle class adults to the inner-city neighborhoods. The motivation was purely commercial since the city wanted twenty-four-hour activity to keep its commercial areas active. It was a critical requirement in a city where 95% of the work force commuted. The need was articulated by one of the city's commercial powers, Kenneth Dayton, president of one of the nation's largest department store chains. Envisioning the downtown as a "super shopping center," he felt that the middle class was necessary for commercial success in the downtown. He told the Downtown Council, "If shopping centers are successful because they are where people live, then downtown must once again become a place where people live. The Loring Park project comes to mind and can be a powerful stimulant to the growth of downtown Minneapolis."⁴

A key attraction of the commercial downtown was the Nicollet

Mall, one of the first urban pedestrian shopping malls in the country. The Loring Park project would be at the termination of this mall, adjacent to a nine acre urban park and near such urban amenities as the Walker Art Center, the Guthrie Theater, and the new Orchestra Hall, the latter recently completed on the other side of Nicollet Avenue from the project area (see Figures 3-27, 3-28, 3-29). For middle class and upper income sensibilities, the project seemed to have an ideal location.

The eventual execution of the project employed many of the planning policies of the urban renewal programs of the 60's. Unlike the 121A tax agreement of Massachusetts, which leaves site preparation and relocation to the private developer, the tax increment financing plan resembled an urban renewal effort. After issuing general obligation bonds, the city would fix a base rate tax assessment, based on the full faith and credit of the city, on the property to be acquired. With the money gained from the bonds, the city purchased the land, relocated the residents, and made site preparations in accordance with the development plan created by the city's planning staff without public involvement. When the land was prepared, the developers were selected to build projects that would generate sufficient property taxes over the base rate, called tax increment, in order to retire the bonds. The period of the bonds was twenty years, after which time the city would realize the increased taxes for other municipal purposes.

In order to develop this project, to generate the necessary taxes, and to attract the middle class working adults, the project



Figure 3-27

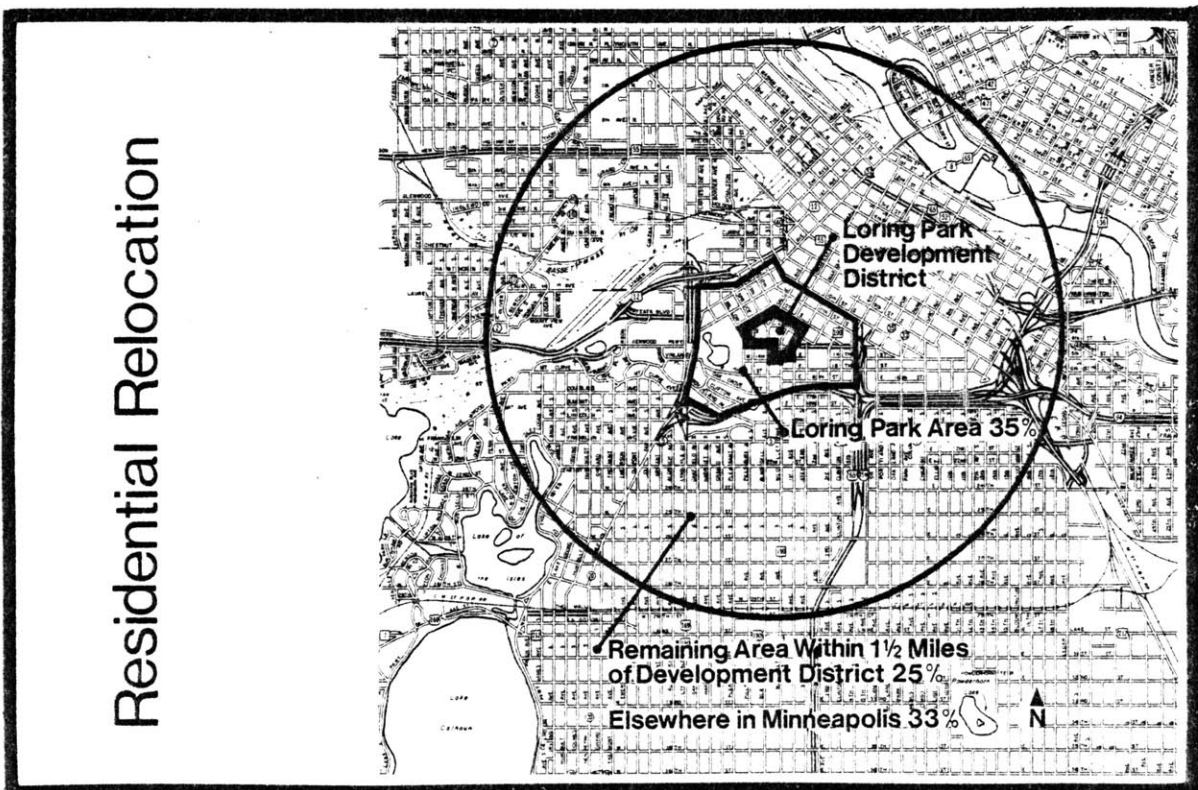

Figure 3-28

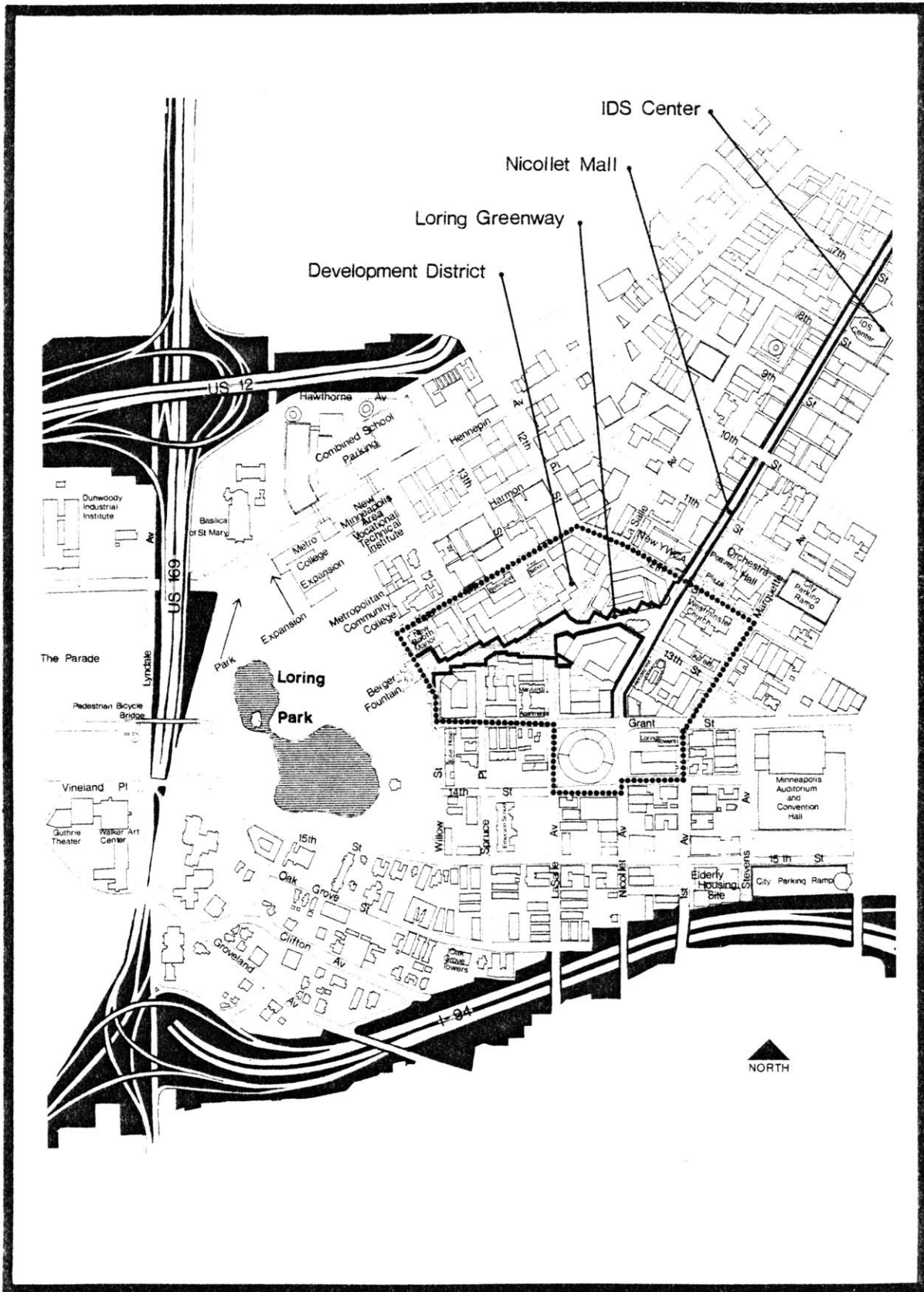

Figure 3-29

was planned as high-rise housing reminiscent of Eastside Manhattan. The result was a Superblock City image foreign to the city and resisted by the residents who had no voice in the planning process and who saw their neighborhood destroyed. Their complaints were typified by the following comments in the Loring Park Community Crier of January, 1977:

"We request that Willow Street be left open permanently to help ease air pollution on other streets and to provide a minimal north-south route through the neighborhood."

"As has been pointed out in the Draft EIS, three different grids converge in the Loring area, thus making it rather confusing. The city has exacerbated the confusion by closing several streets and adding a fourth diagonal--the Greenway. We would like to point out that confused and frustrated motorists are seldom an advantage to pedestrian or cycle traffic."

"We question whether any level of government funded policy should ever undertake to destroy a major portion of a city's sound, adequate, low-rent housing stock in order to replace it with subsidized housing for upper-middle income people for whom many options are available. In the displacement of persons from Loring, the city not only disrupted an excellent community of low income, self-sufficient, mostly elderly persons, but also forced many of these proud people into subsidized housing or welfare in other forms."⁵

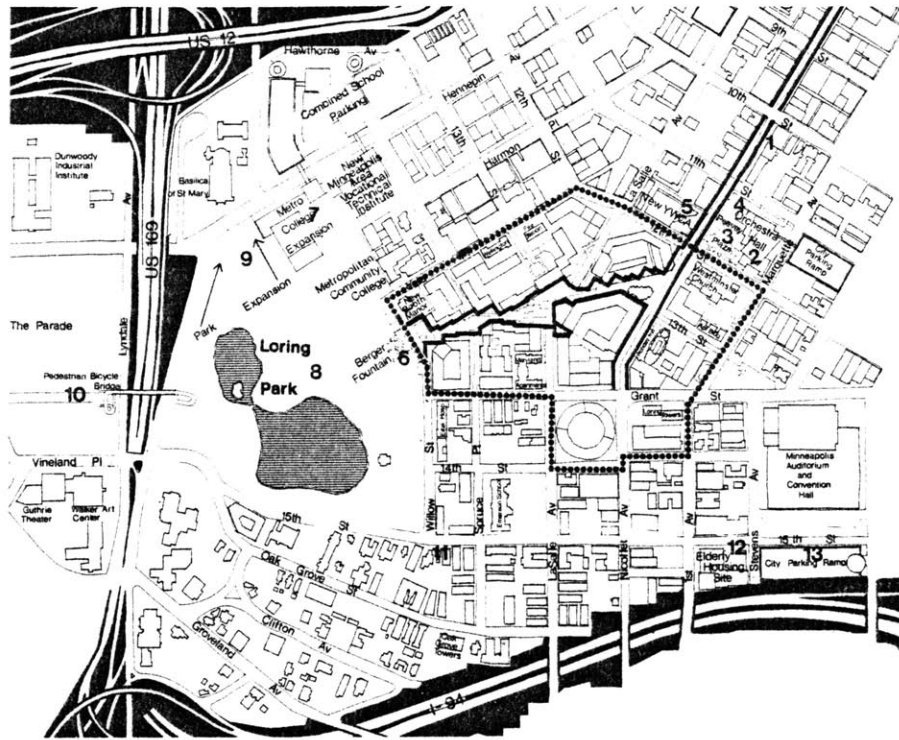

Area Activities

The Loring Park Development staff has been involved with activities surrounding the Development District to insure that

the combined public and private effort will produce the maximum beneficial impact on the Loring Park Area.

1 Nicollet Mall
 Completed in 1968, Nicollet Mall has received international acclaim. From its present terminus at 10th Street the Mall will be extended four blocks to Grant Street as an exclusive pedestrian and public transit route which will tie the Loring Park Development and other area activities to the Central Business District.

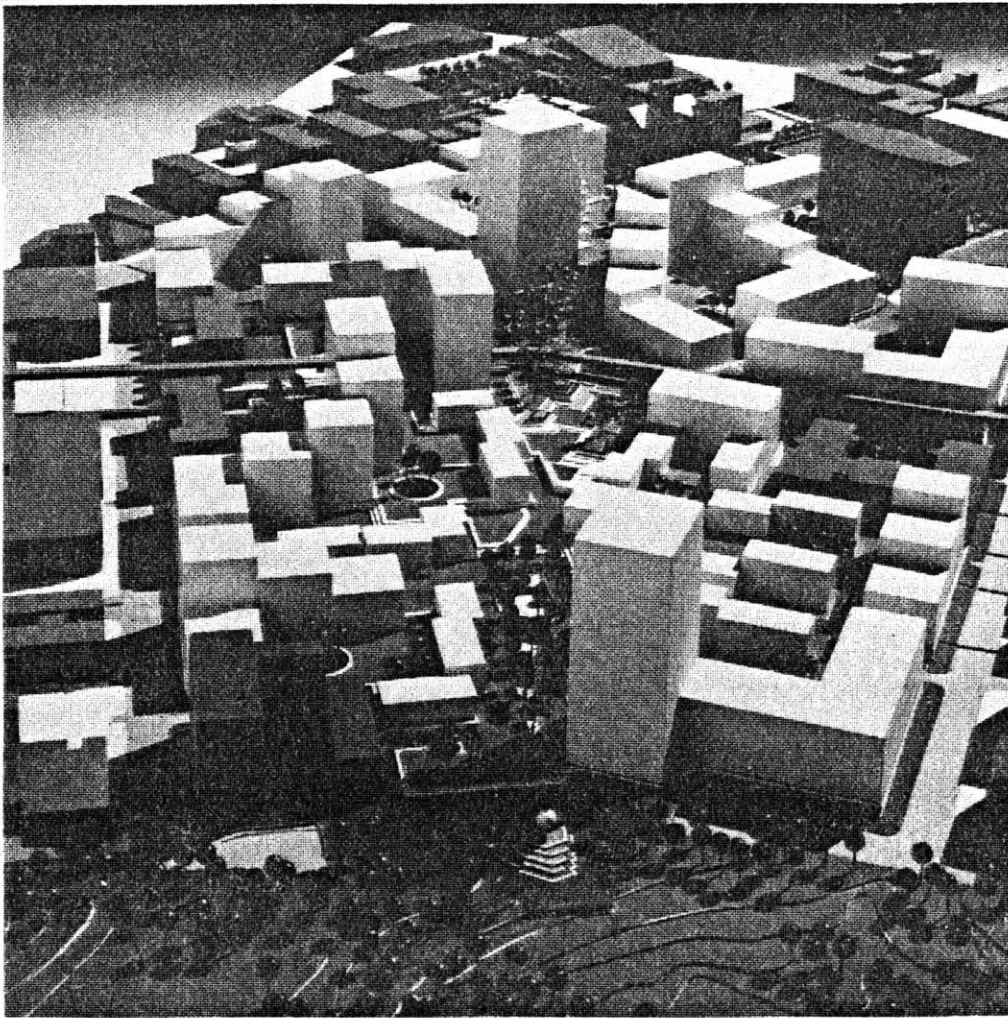

Figure 3-30

The Loring Park Development project coordinator at a later point had this to say about the issue of displacement: "We're making no bones about it. We're turning around the district for middle- and higher income people as we promised." When residents asked for existing buildings to be recycled after the development plan languished with inactivity due to the financial impacts of the oil crisis in 1973 and the New York fiscal crisis in 1976, the project coordinator said the following: "It's not only a question of rehabilitating buildings. It's a question of finding parking room and some other developer to develop the rest of the parcel to pay off the bonds for the District."⁶ At that time 25 million dollars in bonds had been issued for the District, and construction under the tax increment financing plan was behind schedule. The desperation of the moment led the coordinator to say, "When you have a developer before you, its a question of meeting his plans."

Eventually the project was refinanced, and now construction seems to be moving on several sites. One sees a great heterogeniety emerging where mid-rise and low-rise condominiums stand side by side. Streets adjacent to the park have been made into cul de sacs so the public can no longer gain total access to the park which is now combined with luxury housing with the closure of Willow Street (see Figure 3-31). One's first reaction on seeing the various developments reach completion is to borrow Charles Moore's phrase, "it's an architectural zoo" (see Figures 3-33 and 3-34).

The physical criteria for developing the Loring Park master plan were purely utilitarian (see Figures 3-35 and 3-36). The Radiant, Superblock City aspect of the master plan is evident in the first



VIEW FROM LORING PARK

INTRODUCTION

The task reports submitted here - IV - Urban Design Plan and VI-Public Open Space Schematics - Loring Greenway, along with Market Report by Economic Research Corporation form the planning basis for the development district. The background for planning determinations leading to these plans is documented in the Task I and II Report - Urban Design Concepts, submitted in June, 1973. This introductory section includes a general description of the

project, illustrated by site plan, site sections and photographs of the model, and descriptions of following technical sections of the report.

The Loring Park District is planned as a medium-density residential community of some 2,700 dwelling units clustered around the Loring Greenway, a public open space connecting Nicollet Mall Extension with Loring Park.

The planning and development of this large scale residential community is a significant step in integrating the environs into a cohesive downtown, contributing to the ongoing goal of economic health and viability for the City of

Figure 3-31

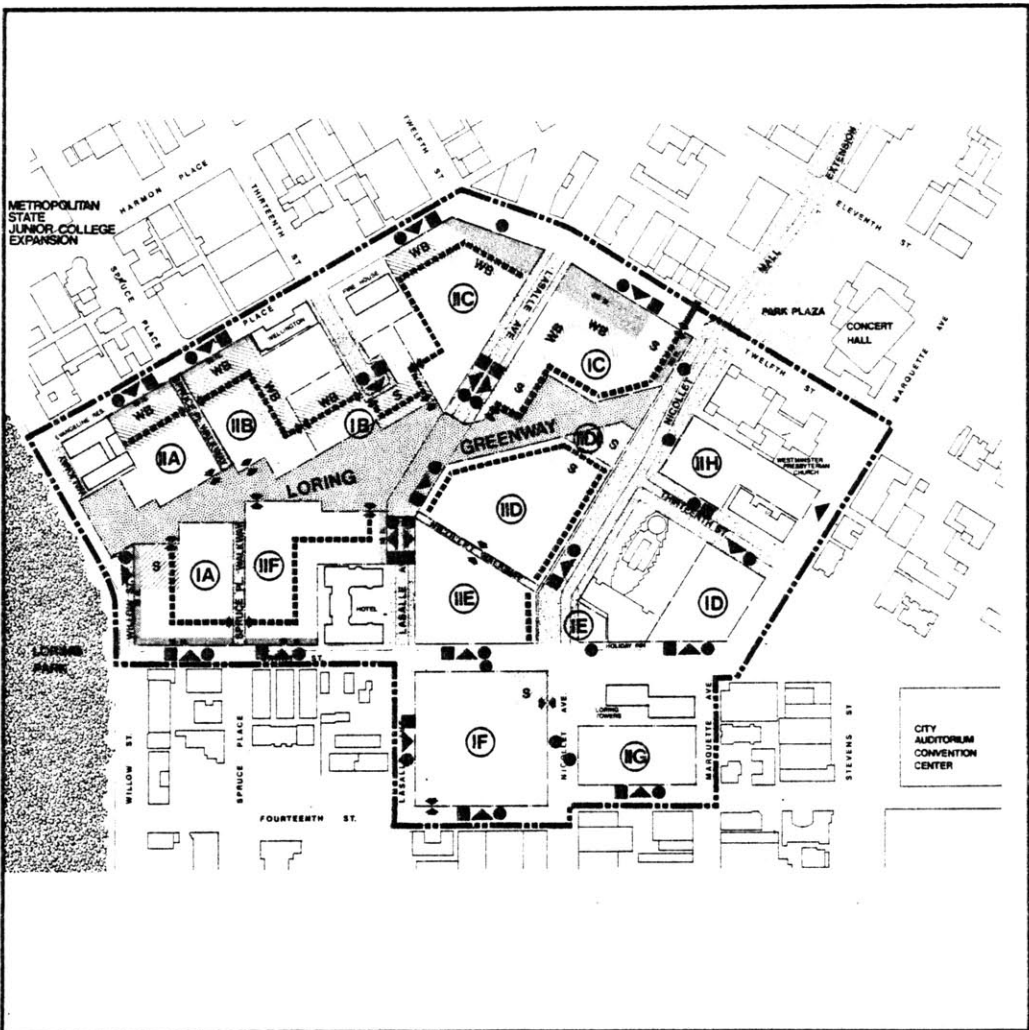

URBAN DESIGN PLAN
LORING PARK DEVELOPMENT
DISTRICT MINNEAPOLIS, MINN.
 CITY OF MINNEAPOLIS

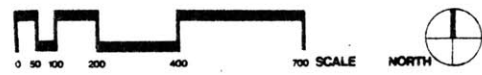

PRIVATE DEVELOPMENT PLAN

- LEGEND**
- ▶ PARKING ACCESS
 - VEHICULAR DROP-OFF
 - SERVICE COURT
 - ⊛ SPECIAL URBAN DESIGN OBJECTIVE
 - WB WEATHER BARRIER
 - ◆ PEDESTRIAN ENTRY
 - ▬ ARCADE
 - ▬ SKYWAY
 - ▬ SETBACK
 - PARCEL

Figure 3-32

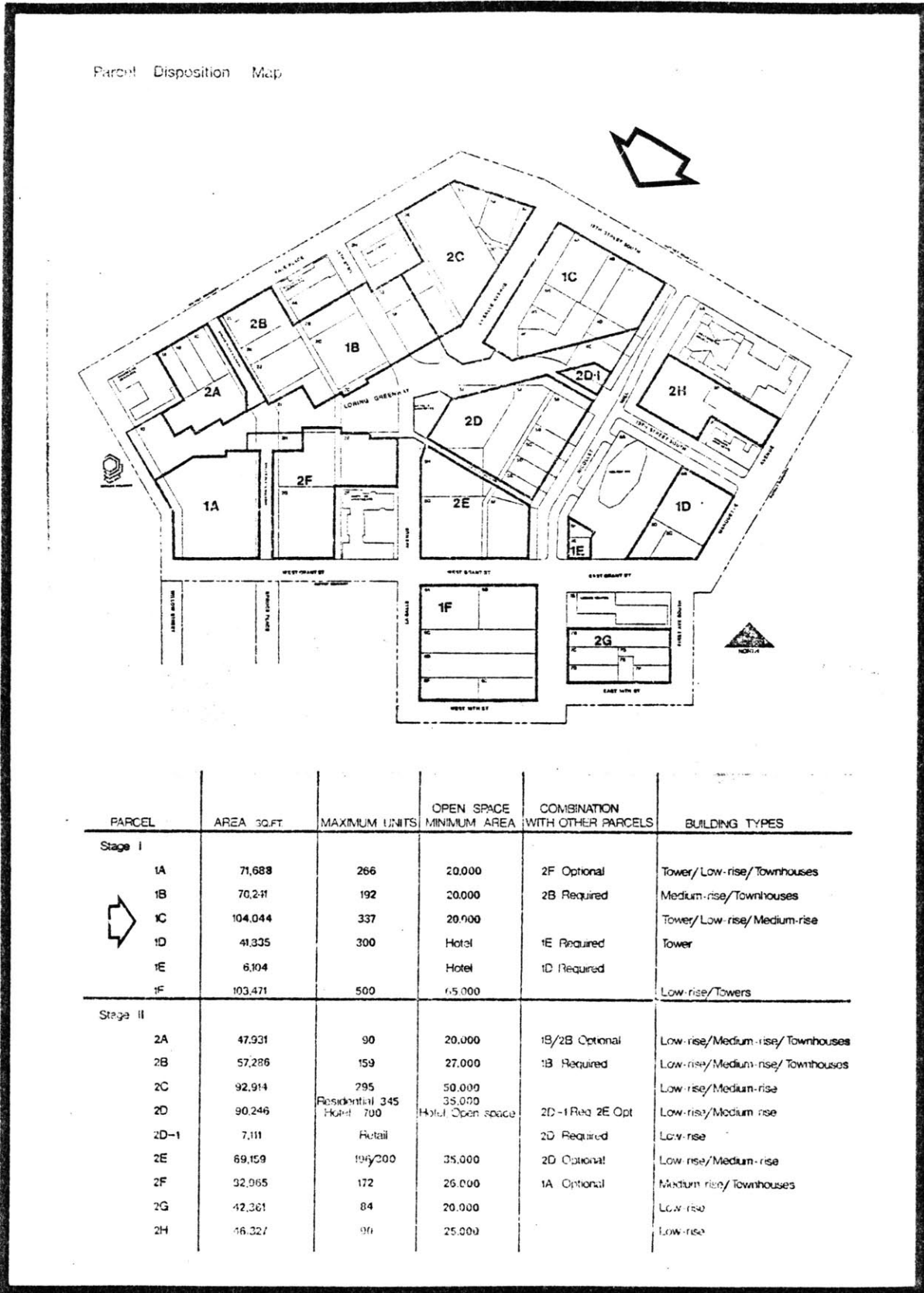
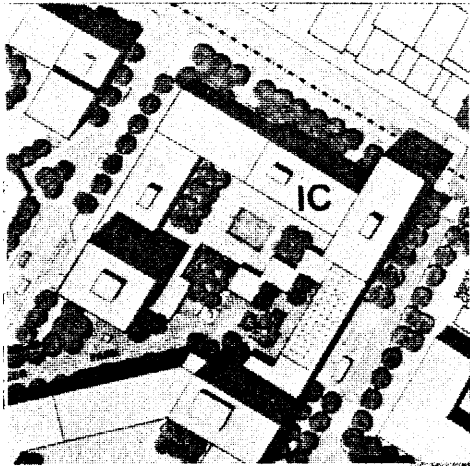

Figure 3-33

PARCEL IC**DEVELOPMENT PROGRAM**

Parcel IC to be developed as one parcel. The developer may construct floor area under the Greenway for required parking use.

USES**Principal Use**

Residential

Accessory Uses

Parking
 Open Space
 Retail
 Food Stores
 Dry Goods and Variety Stores
 Apparel Stores
 Household Goods Stores
 Branch Banks
 Restaurant

CONTROLS AND REQUIREMENTS**Residential**

Floor Area Ratio - maximum 3.5
 Dwelling Units - maximum 337

Retail

maximum floor area 20,000 square feet

Open Space

minimum 20,000 square feet

Parking

minimum 1/1 ratio to dwelling units

Parking Access

from 12th Street or La Salle Avenue

Vehicular Drop-Off

from 12th Street or La Salle Avenue

Vehicular Service Court

from La Salle Avenue

Figure 3-34

URBAN DESIGN OBJECTIVES

The objectives of marking an accent point along the Greenway and of terminating the 13th Streetway vista from the Auditorium should be attained by a tower apartment building at the west corner of the parcel of a minimum of 20 floors of a maximum typical floor area of 10,000 square feet.

The objectives of marking the entry to the project and the Greenway along Nicollet Mall Extension should be attained by a slab apartment building at the east corner of the parcel of a maximum of 10 floors of a maximum typical floor area of 10,000 square feet. The building should be sited so that its facade relates in scale to the facade of the Westminster Presbyterian Church across Nicollet Mall Extension.

The objective of enclosing and providing surveillance of the parcel's open space court and the public open space of the surrounding streets and of providing a weather barrier should be attained by continuous or semi-continuous buildings along 12th Street and La Salle Avenue.

The objective of providing open space activity on the Greenway should be attained by locating one floor retail uses along the Greenway, the building facade to be set back from the parcel line in a serrated fashion, as shown on the Illustrative Site Plan.

The objective of providing sunlit open space in the parcel's court should be attained by limiting the building heights to one floor (except for the tower) along the Greenway.

The objective of providing the maximum of useable parcel open space should be attained by locating retail uses and all required parking spaces under a covering deck, which may be raised above the surrounding grade a maximum of one floor, allowing natural light and ventilation for the parking level below. The open edge of the deck should be treated with landscaping or a grille enclosure.

The objective of providing attractive and useable parcel open space should be attained by landscaping of the open space surface with trees and shrubbery and the provision of sitting and recreation areas.

The objective of providing a continuous pedestrian access and circulation system from the public open space through the parcel open space should be attained by the provision of a pedestrian entry from the Greenway along the southern edge of the parcel.

The objective of providing a continuous interparcel weather-protected pedestrian walkway should be attained by providing a covered arcade as part of the building and at the edge of the Greenway and Nicollet Mall Extension. Provision should be made to allow full enclosure and temperature control of the arcade if desirable at a later date. Entry to the arcade should be coordinated with that of the public Greenway Arcade over La Salle Avenue.

The objective of connecting the arcade system to the Minneapolis Skyway System when and if it is extended down Nicollet Mall Extension should be attained by the provision of a two story vertical circulation space at the termination of the arcade at the corner of the parcel at Nicollet Mall Extension and 12th Street.

Figure 3-35

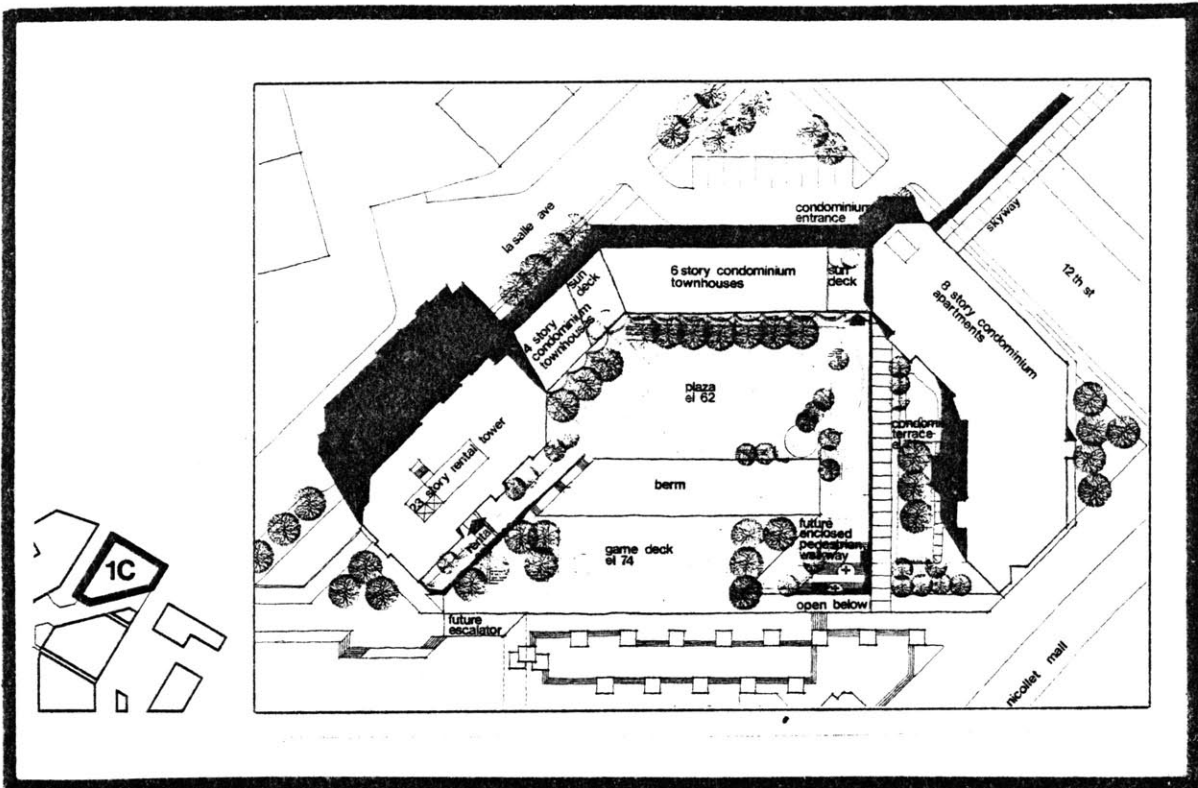

Figure 3-36

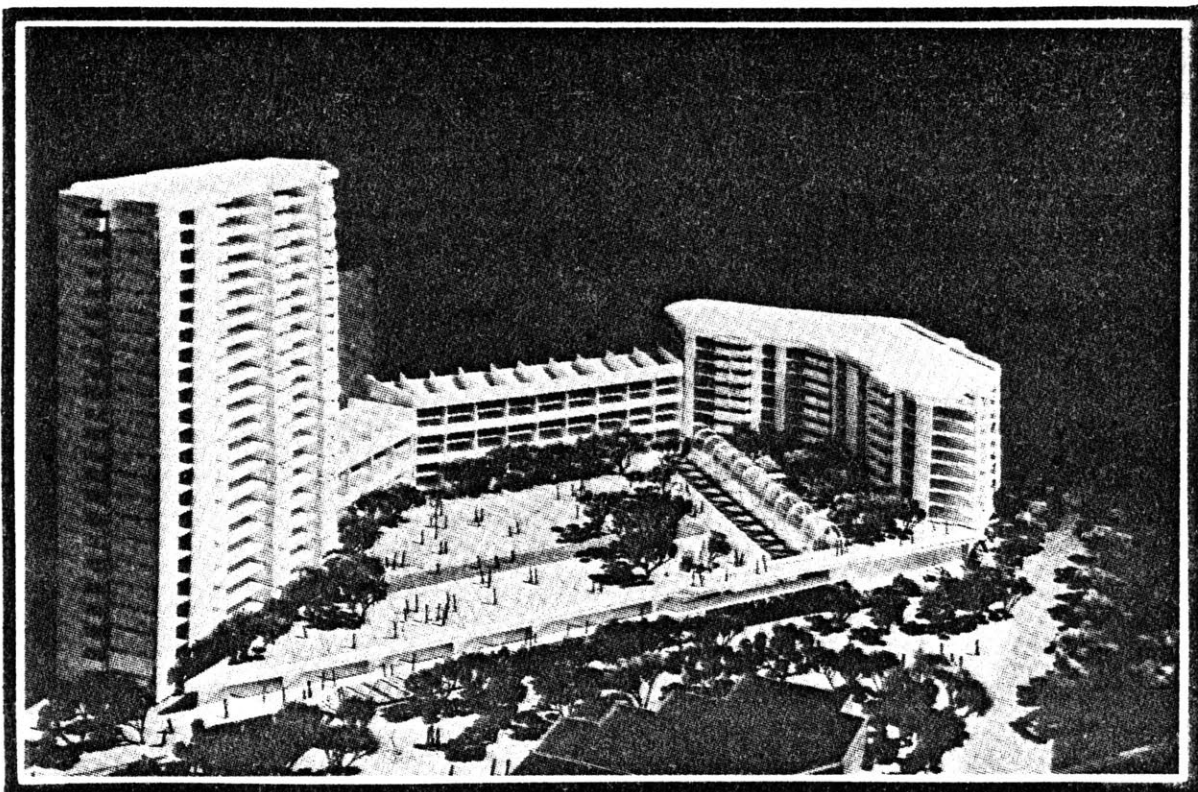

Figure 3-37

master plan. These qualities were increasingly emphasized and the project finally emerged. The site plan for the completed development, less Parcel IIB is, with one exception, total Radiant City, completely indifferent to its context (see Figures 3-37, 3-38, and 3-39).

The level diagram shows the development activity occurred at Level 2 without influence from Levels 3 and 4. Because of the interventions indifference to its context, it is impossible to construct a pathway diagram from an observer's perspective.

PRE-COMPLETION
PRICES

Move up to downtown...
...to the
cultural heart
of the mall.

Sales now being made for March '79
occupancy in the new 23-story tower.

At the apex of the city's magnificent new Loring Park development rests 1200-On-The-Mall—elegant new condominium residences in the new 23-story tower (now under construction). You'll live your most fulfilling lifestyle amid the vibrant activities which make the city distinctive, yet you're free of the constraints of ordinary home maintenance and rush-hour commuting. Just a stroll away from fine shopping, evening dining and entertainment at its best. Orchestra Hall is a short block away and just 2 blocks and "through-the-park" brings you to the Walker Art Center and The Guthrie. You'll find spaciousness, luxury and elegance with builder Ted Glasrud's particular attention to detail. Choose from many resourceful floor plans—2 and 3-bedroom suites from 1118 to 1771 sq. ft. (\$70,700-\$142,800) plus custom combination suites for as much room as you desire. Fine carpeting, dishwasher, range, disposal, full security system, underground parking, sauna, exercise room and community room. Preview the tower plans now. Open weekdays 9:30 a.m. to 7:30 p.m., weekends 10 a.m.-6 p.m. 332-3497.

The Tower of
1200
on the Mall

Your prestige address at the
cultural heart of the mall.

Where 12th meets Nicollet.



PRE-COMPLETION
PRICES

Move up to
downtown...

...to the natural
peace of the park.

Loring Way now under construction
on the edge of Loring Park.

We're beginning a new life in downtown Minneapolis. Loring Way... elegant new condominiums... bounded by a greenway and a park and surrounded by trees. Loring Way is more than a home... it's a new kind of freedom. Freedom from daily commuting. Freedom from ordinary home maintenance. Freedom to enjoy life to the fullest! The Guthrie, Walker Art Center and Orchestra Hall within easy walking distance. Theaters, restaurants and night clubs just a spur-of-the-moment away. And the peace and solitude of beautiful Loring Park just beyond your windows. All this plus the quality on which Ted Glasrud has built his reputation. 19 versatile floor plans—1, 2 and 3-bedroom styles, 779 to 1799 sq. ft., many with 2 baths, some with large dressing rooms. Prices start at \$49,700. Come preview the plans for our luxurious eight-story building featuring underground parking, balconies, exercise room, sauna, whirlpool and more now at our sales office at 1200 on the Mall, 12th and Nicollet. 332-3497. Suite reservations now being accepted.

Loring Way

On Loring Park where Willow St. and Loring Greenway meet.



Figure 3-38

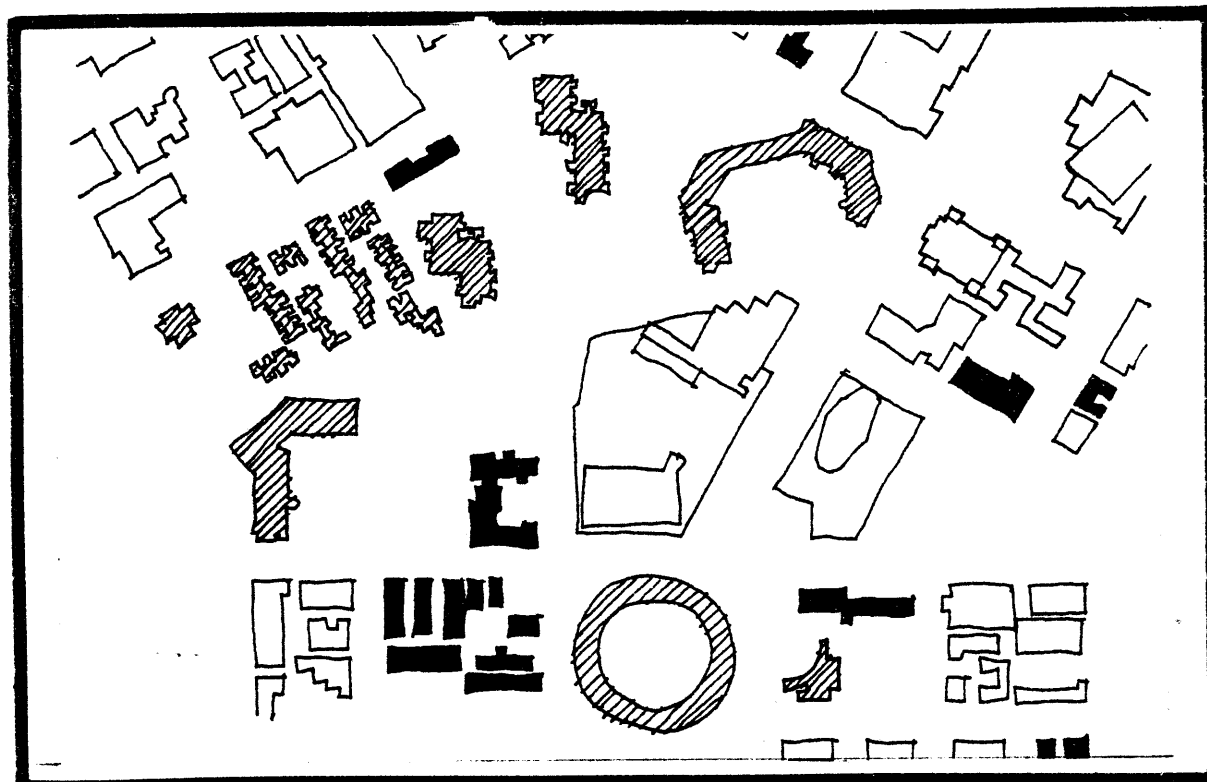

Figure 3-39

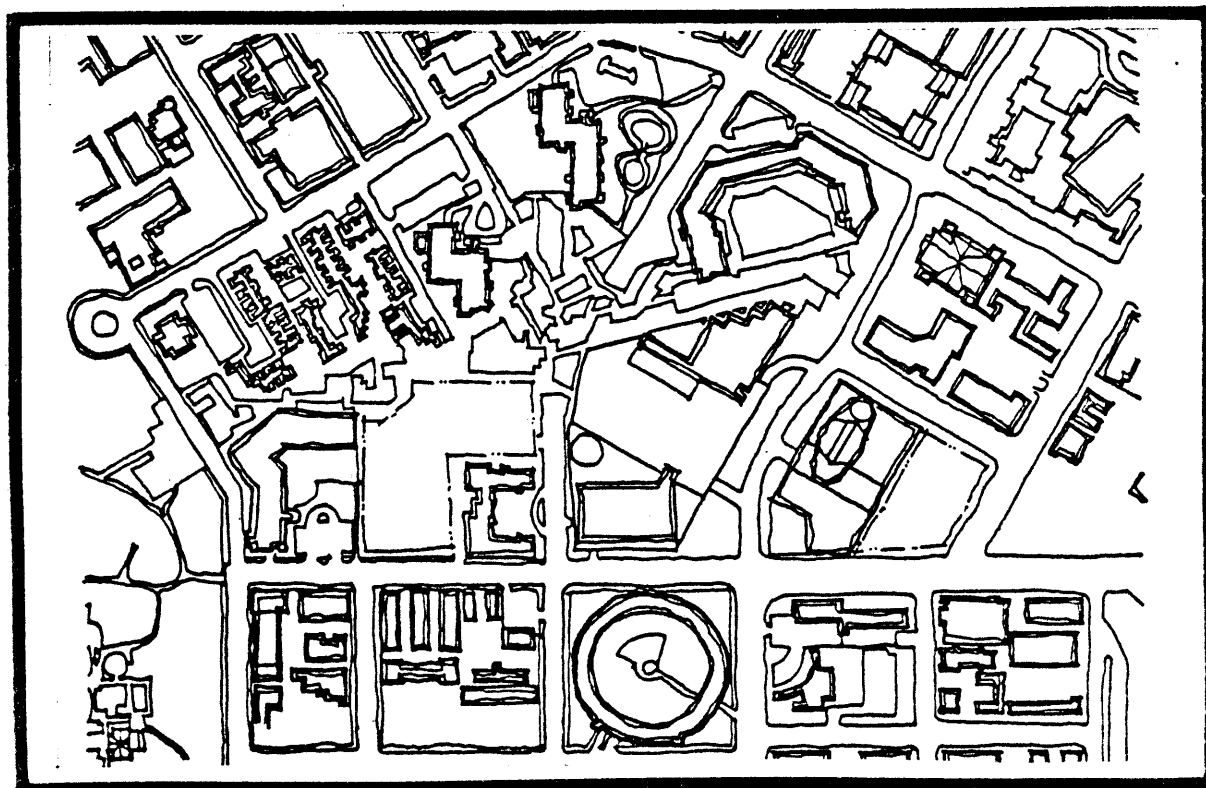

Figure 3-40

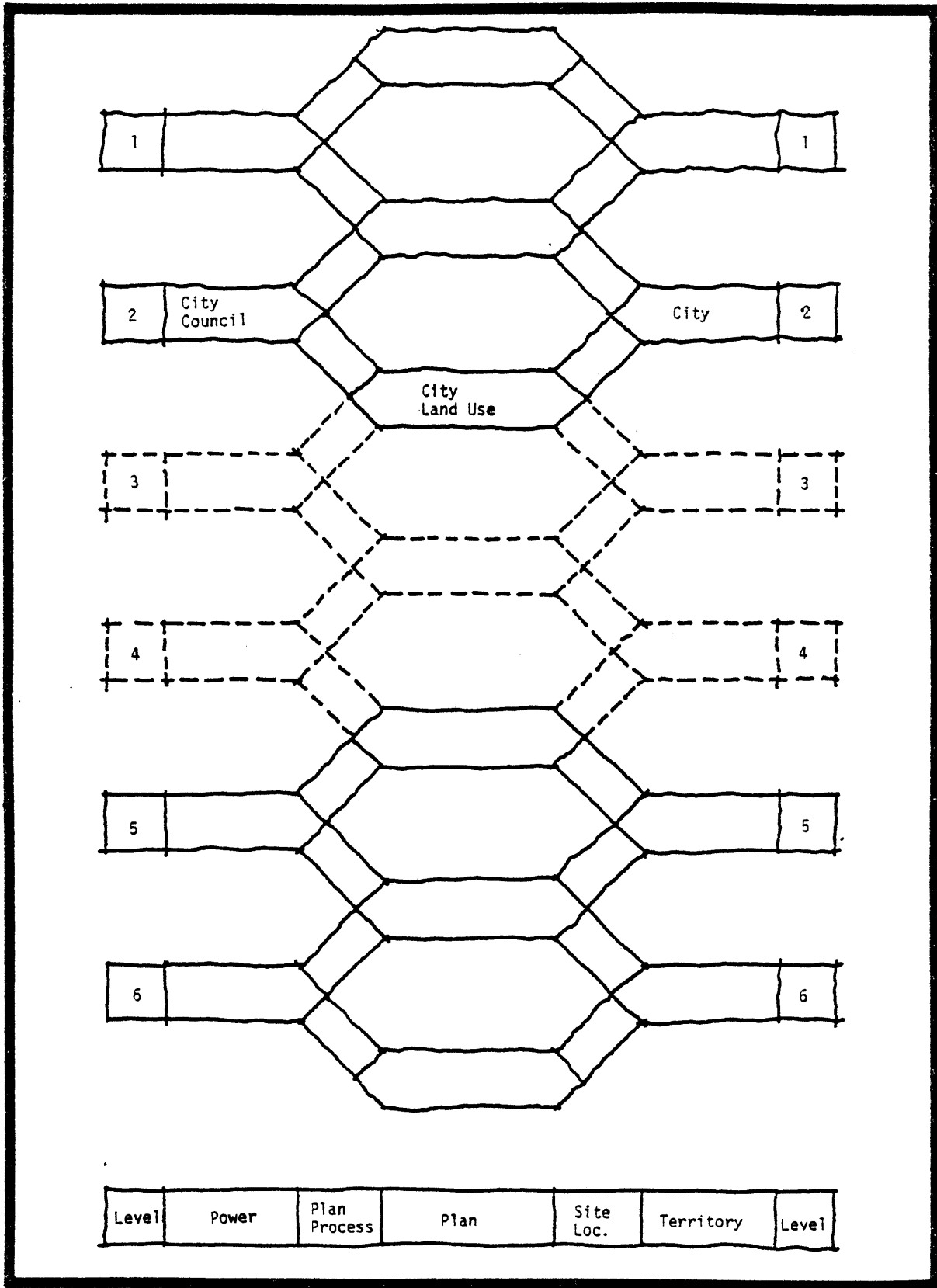

Figure 3-41

We have seen in our review a variety of physical interventions in districts; some occurred with greater contextual sensitivity than others.

<u>Example</u>	<u>Levels</u>	<u>Context</u>	<u>Intervention</u>
Summit Hill	5 to 4	Block City	Block City
Exeter Towers	5 to 4,3,2	Block City	Block City
Twin Oaks	5 to 2	Block City	Superblock City
Villa Victoria	5 to 4,3	Block City	Garden City
Loring Park	2	Block City	Superblock-Radiant City

The above summary shows us that where Level 3 and 4 involvement occurred, the intervention was sensitive to existing context. In Summit Place, the small-scale developer complied easily with the informal overtures from the community. Historic guidelines and professional review in Exeter Towers kept a higher density housing solution compatible with its context. In Villa Victoria, a sensitive architect working with the present residents maintained the quality of the existing context with slight modifications. Town Oaks, on the other hand, with its special (PUD) zoning ordinance, was planned by the architects and the developer without Level 3 and 4 involvement. Loring Park showed the same indifference to context and created a similar project image on a much greater and more destructive scale. The development project was conceived and developed solely by the city's planning staff as a Level 2 activity under total professional control without involvement from the surrounding community as lower level participants. It was a replay of the urban renewal policies

of a previous decade.

Consequently we have seen in our case studies a variety of interventions, each using different development models in Block City contexts. Our analytical methods have been particularly useful in this exercise for a number of reasons:

1. The use of the level diagram tends to organize the actors in any land-use planning and design situation. It demonstrates that the most cohesive districts show the active involvement of all levels of community participation in land-use decision making.
2. The use of the thematic/non-thematic conceptualization is useful in determining a point of reference in deciding what built form or open space qualities should be retained and which are unessential.
3. The structure of Block City districts (which typify most urban neighborhoods) is easily seen in the analysis using the built space and open space diagram as a model for the existing context, as seen in Chapter Two.
4. The use of pathway diagrams is a useful derivative from the built space/open space diagram which analyzes critical issues that impact on district continuity. Less abstract for lay interpretation, the pathway diagram can analyze a variety of issues. In our study we will concentrate on materials, dimension, and patterns, realizing that other issues are possible for study as well.

Parts Two and Three will show how the above analytical methods will be useful in developing a design guideline structure to be applied in our study neighborhood, Elliot Park.

Part II

In Part II we will examine planning techniques used at different levels of planning. From this examination our guideline format will be developed.

Chapter 4

Developing Design Guidelines

We saw in the last chapter that situations involving Level 3 and 4 actors developed built interventions that were more sensitive to the existing context. This suggests that if physical interventions were planned for the urban neighborhood shown in Figures 4-1 and 4-2, it would be desirable to have Level 3 and 4 involvement to achieve contextual compatibility.

But why is this necessary? In residential settings, why can't satisfactory contextual interventions occur simply with traditional Level 2 and 5 involvement such as that we examined in Chapter Three? To begin to answer these questions, we must examine three issues: Control, Regulation, and Documentation. In so doing, we should refer to our level diagram as shown in Figure 4-3.

Control of land-use decisions usually exists in the legislative body of municipal government. Generally, depending on the municipal governmental structure, the decisions are first made by the planning commission and then voted on by the city council or the mayor.

Typically, to develop property, the private owner makes planning decisions regarding his or her building development, which are guided by zoning ordinances and the approval of the planning commission, city council, and mayor, depending upon the nature of the building project. It is a direct Level 5 to Level 2 relationship. Here we see that review always has been an internal affair between the property owner at Level 5 and the city council at Level 2. Prior to council approval, zoning issues, i.e. conditional use permits and variances,



Figure 4-1

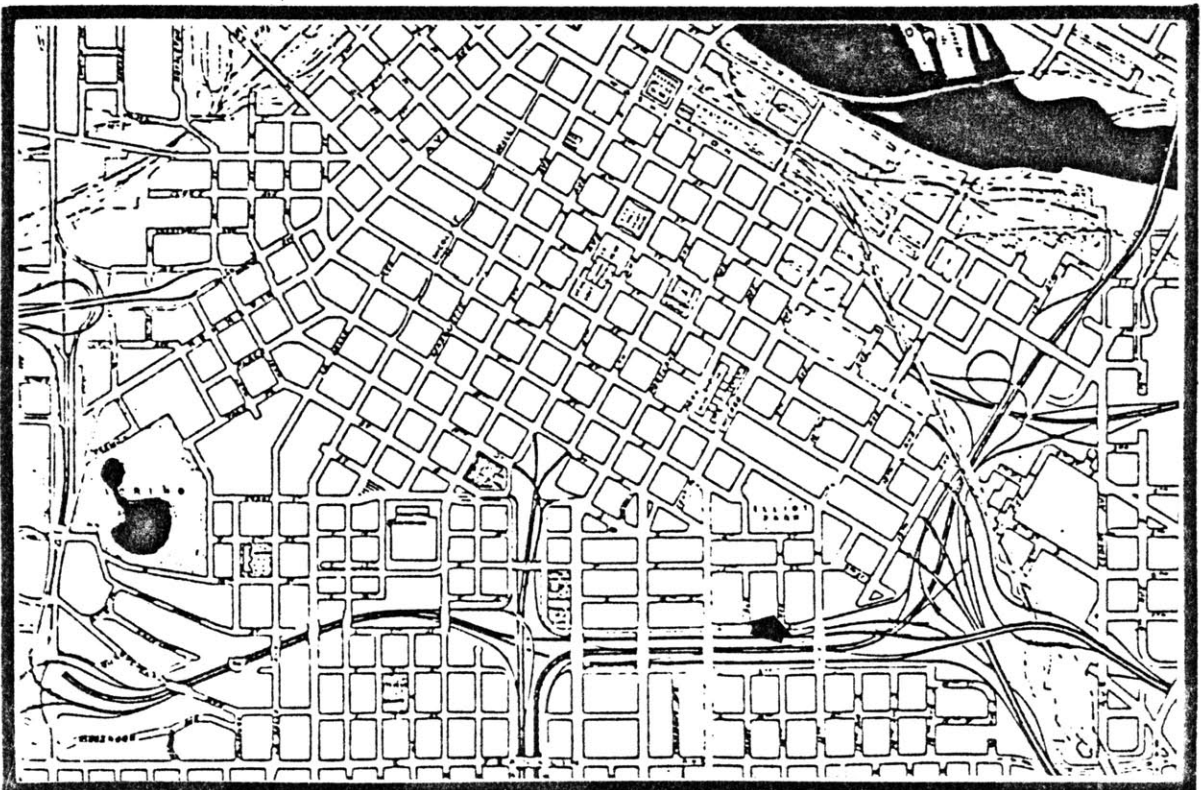

Figure 4-2

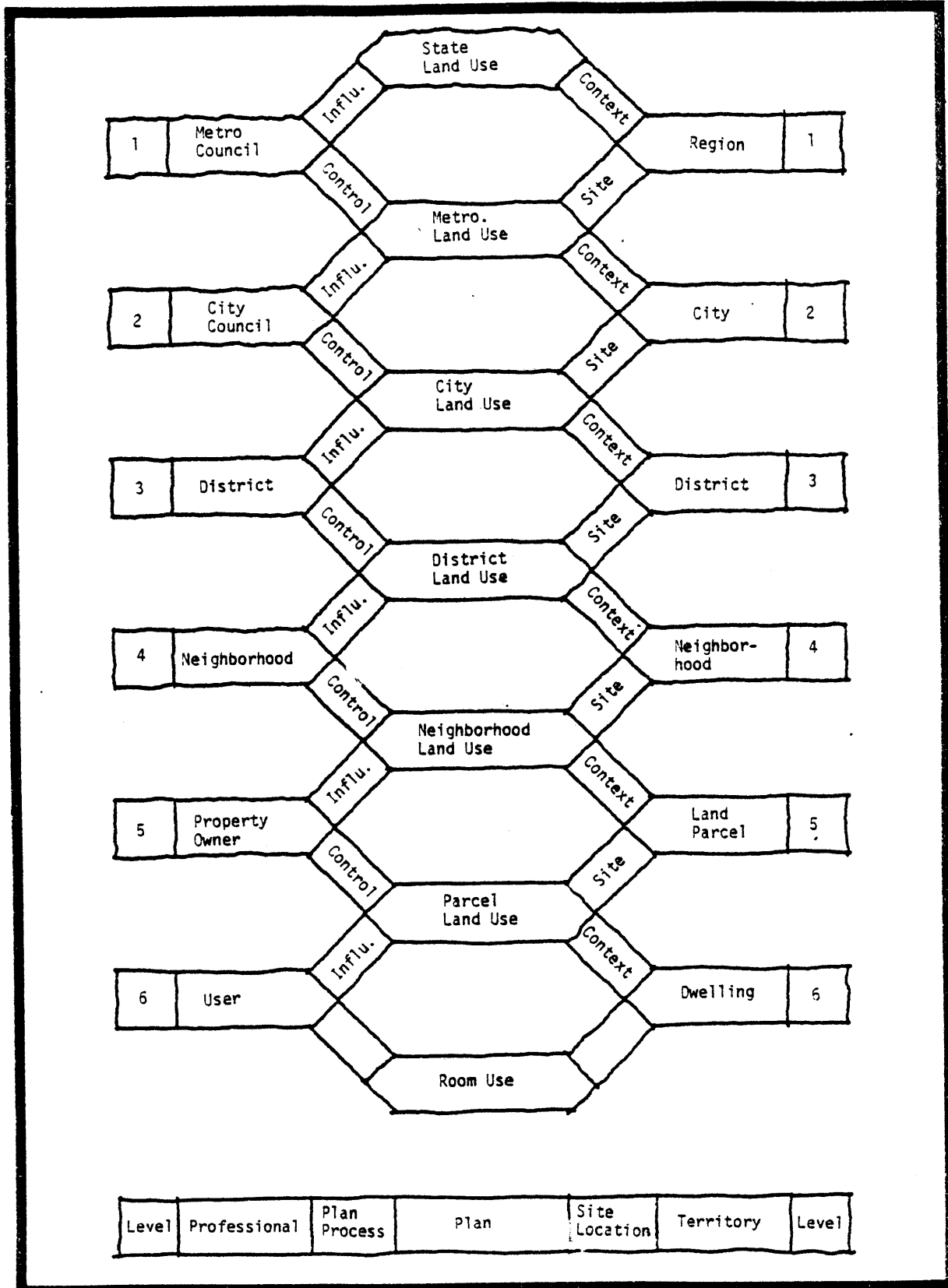

Figure 4-3

are reviewed by the zoning board of appeals, and then by the planning commission, prior to council action. The only impact that Levels 3 and 4 have in the process is in electing the representatives at Level 2. This relationship stems directly from the American political tradition of representative government and from the rights of private land owners to use their property as they wish within the prescriptions of the zoning code.

Outside of routine public scrutiny are the street and road standards of the public works department, as well as the standards of the park department, which govern public open space.

Consequently, the collective control of land has been traditionally very weak; hence, Level 3 and Level 4 activities have been almost non-existent. Exceptions have, however existed in the past with special design districts within the city, the home-owners associations in suburban developments, or with planned new communities. In such cases, the single developer and land owner creates the mechanisms for land-use control by the neighborhood prior to developing the land and selling off the property. We saw such collective control in a design district with the infill example in Boston's Back Bay.

These collective actions are the result of special legislative mandates and establish specific regulations for a given context. By their nature zoning regulations that are in common use between Level 2 and Level 5 actors do not provide sufficient regulation for contextual sensitivity.

In examining the issue of zoning regulations, two questions need to be asked. What is commonly regulated and how is it to be regulated?

To determine what is regulated, we need to look briefly at the history of zoning as a land control mechanism. As a largely post-World War I phenomenon, the original intent of the zoning laws was to prevent nuisances, incompatible functions, and unhygienic conditions based on the absence of sun and air; in short, it was an exercise of public police power in support of public health and welfare.

To prevent such negative situations, district zoning by function was created with morphological requirements based on perceived functional issues in order to create segregated patterns of use.

In Minneapolis, the zoning code outlines morphological criteria based on functional activity. These criteria were often created in early zoning codes after land subdivision had already occurred; for example, central Minneapolis had created a Block City model with 80 foot easements for public streets and 300 foot blocks for private land subdivision before zoning laws were formally enacted. At present, the zoning criteria include the following:

- *lot area
- *lot width
- *side yards (determined by building height)
- *bulk (a measure of land area to total building floor area, shown in Figure 4-4.

These restrictions don't give consideration to contextual compatibility as the only base physical restrictions on functional designation, e.g. residential versus industrial land uses. This system of land use, organization, and subsequent morphological restriction was well suited for the post World War I era of single use zoning. It led to the proliferation of single use functional development (i.e. industrial parks, CBD's, etc.) that worked only so

A. SUBDIVISION REGULATIONS

- 1. Street Easement
- 2. Block Size
- 3. Lot Subdivision
- 4. Alley Easement

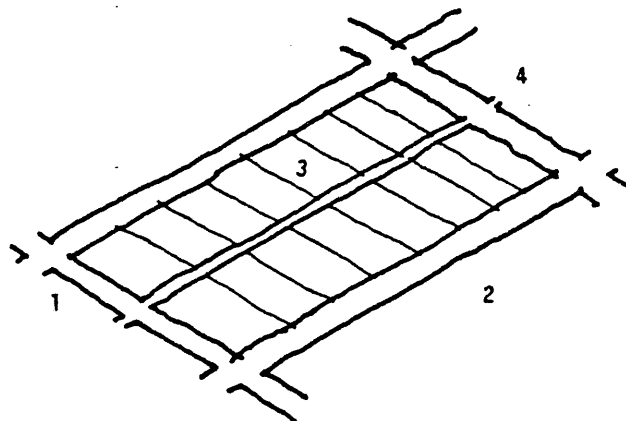

B. DISTRICT ZONING CODE (RESIDENTIAL)

- 1. Lot Area $XY = 7,500$ SF

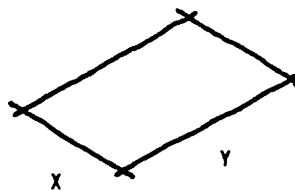

- 2. Lot Width $x = 50$ Feet

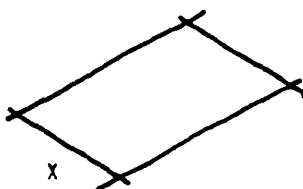

- 3. Yard Requirements

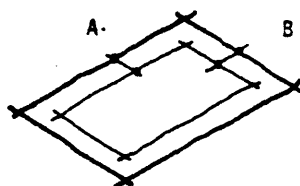

- 4. Bulk Requirements FAR 1.9

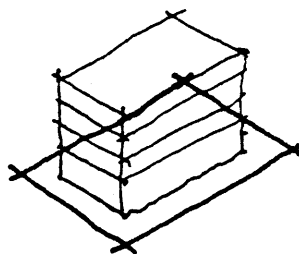

Figure 4-4

long as there were inexpensive commercial modes of transportation to get from one place to another, e.g. from downtown CBD's to suburban residential areas.

Thus the historical patterns of mixed use, where work-place and housing were in close proximity, disappeared. All functions became segregated. Now with the rising costs of energy, we see the folly of these policies and are trying to recover mixed use functional patterns. Present zoning requirements are inadequate to deal with mixed use activity. Further guidelines and documentation must be developed to identify and resolve the conflict of mixed functional uses.

Documentation with land-use issues has always been closely related to professional activity. It goes without saying that documentation serves as a medium to identify concerns and issues. Over time, however, our thinking often becomes limited to the issues that our documentation portrays.

Typically it is only land-use and zoning issues that are under the public scrutiny. The street standards of the public works department and the open space standards of the park department often are not. It was not until the recent publication of the work of John Habraken in SAR '73 that a formulation was developed which combined zoning, street, and open space standards in a systematic documented form. For the purpose of developing design guidelines, however, we will confine our study to the forms of land-use documentation that are in common practice at the different levels of land-use planning and design.

Documentation is an issue closely related to professional activity. If we look at our level diagram again, we see how the design professional works at each level. Level 2 shows the typical role of the urban designer, and Levels 5 and 6 show the conventional roles of the architect. Levels 3 and 4 show the emerging role of the urban designer, which is developing simultaneously with these levels of urban planning activity (see Figure 4-5).

At Level 2 we see the urban planner who helps to plan urban land-use patterns via proposals to the Planning Commission for new development. Often this is in the form of land-use maps that we saw in Figures 2-3 and 2-4. More frequently, however, is the need for large project planning analysis using visual city form analysis as a basis for land use decision making. This activity is shown in the proposal for urban edges, where urban planners explored development potentials around the Loring Park Development District. A common visual analysis of the study area was done together with an area interview. The analysis employed quasi-Lynch techniques (see Figure 4-6).

Design proposals came from unilateral decisions by the planning staff without any meaningful resident involvement. Two "nodes" were created by the study: Butler Plaza and Harmon Min-Mall (see Figure 4-7). The design proposal is the imposition of a Radiant City model upon an existing Block City model. The image was not a logical result of the superficial analysis; it was simply an imposed preconception. The planner at this level works directly for city government, often isolated from lower level contact. Typically it is from studies such as this that development districts are created and zoning changes are enacted.

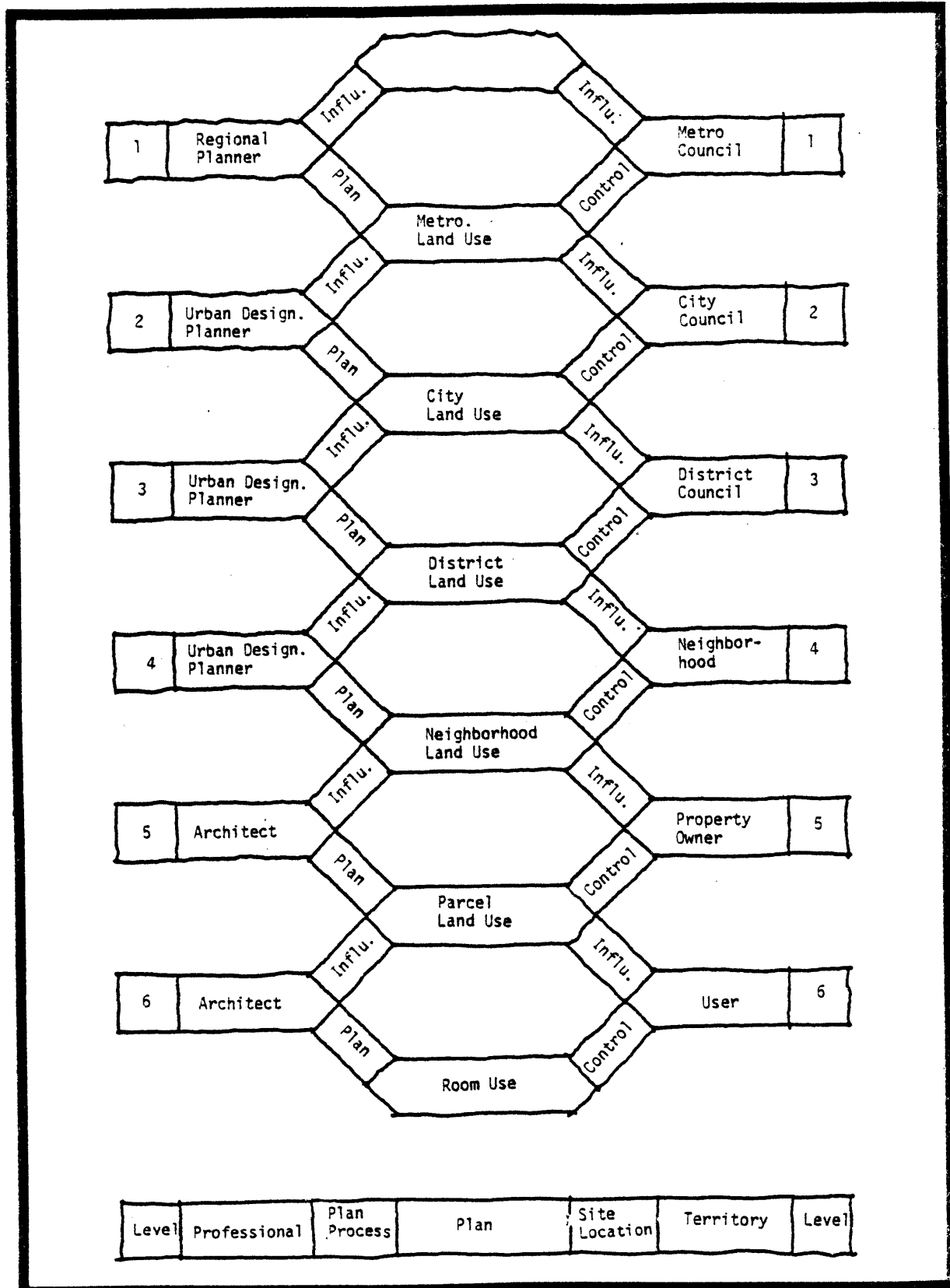
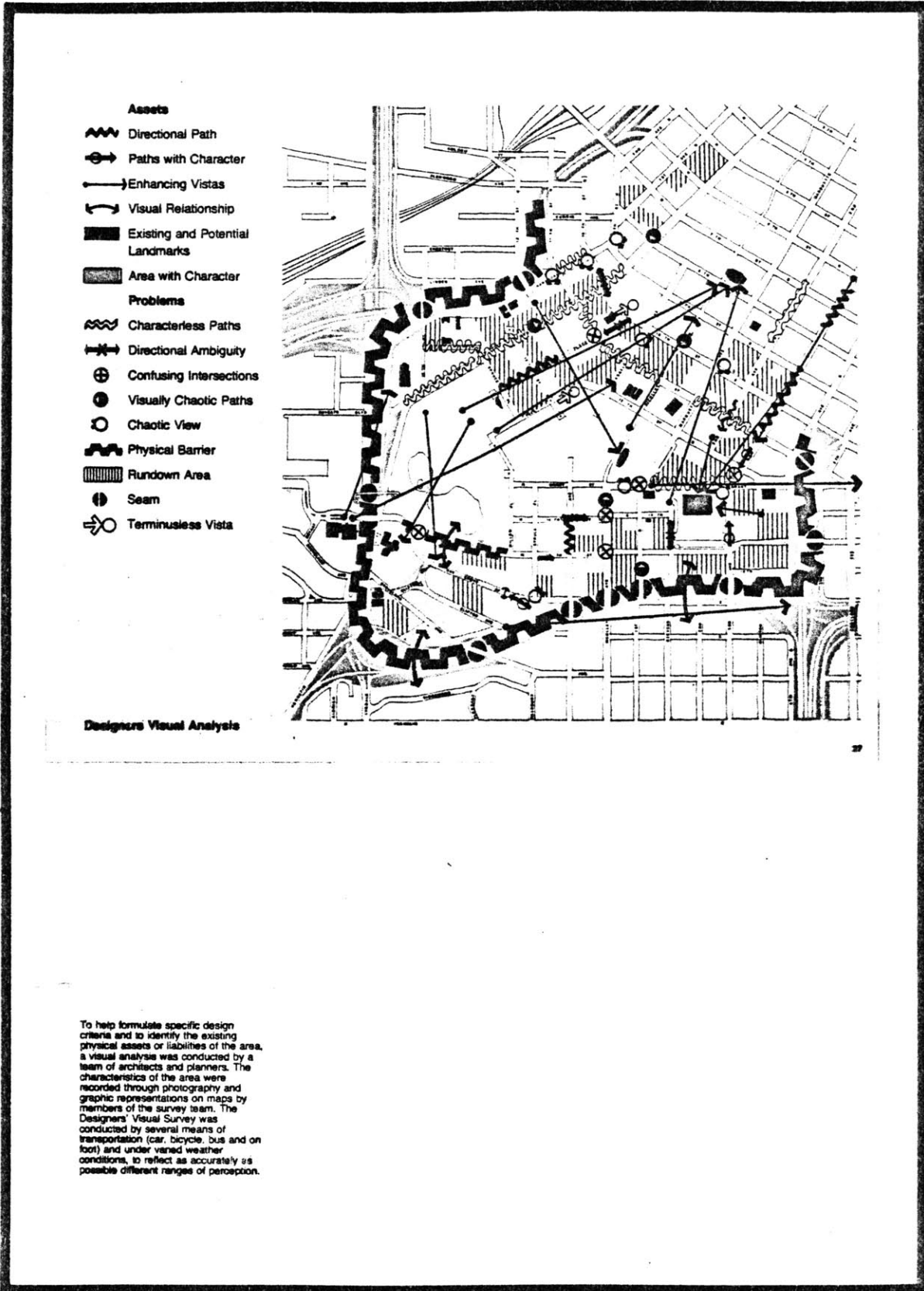

Figure 4-5



To help formulate specific design criteria and to identify the existing physical assets or liabilities of the area, a visual analysis was conducted by a team of architects and planners. The characteristics of the area were recorded through photography and graphic representations on maps by members of the survey team. The Designers' Visual Survey was conducted by several means of transportation (car, bicycle, bus and on foot) and under varied weather conditions, to reflect as accurately as possible different ranges of perception.

Figure 4-6

Figure 4-7

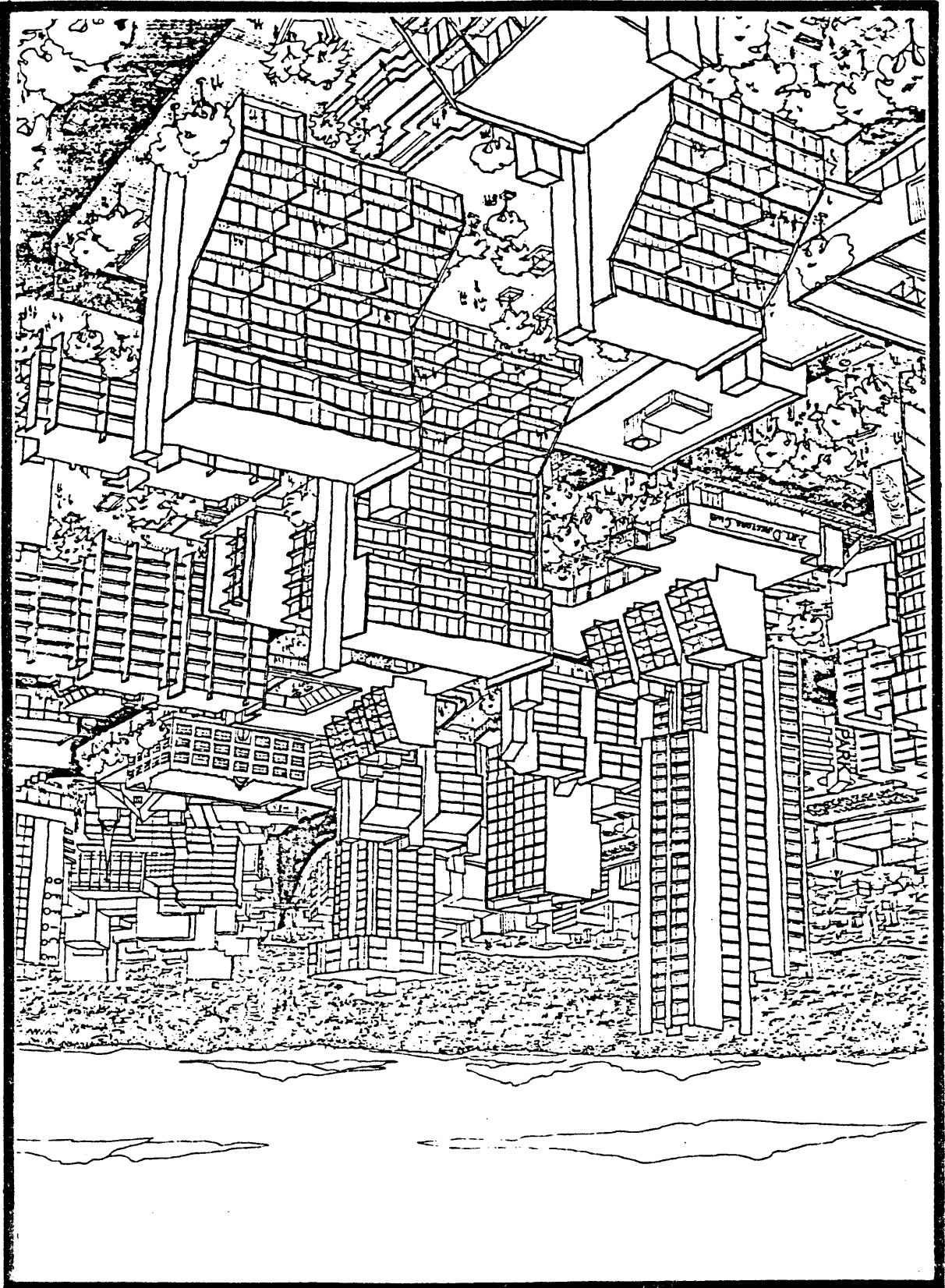

A common Level 3 urban design involvement is shown in Figure 4-8. Here the urban designer attempts to demonstrate housing infill possibilities on several given sites. The existing buildings are colored in black and the proposed infill buildings are shaded with diagonal lines.

Again we see several design alternatives placed in an existing context without examining in detail the necessary requirements of contextual conditions, i.e. facade height, setbacks, scale, building rhythm, and so on. This situation is very common when professionals bring preconceived building models to an existing context, i.e. Radiant City models superimposed upon a Block City model. It is done instinctively and erodes the quality of the street and sidewalk, not to mention the morphological quality of the district itself.

The next study was conducted at Level 4 by architectural students working with community members through the Community design Center in Minneapolis. It shows a great deal of specificity via "design ideas" which reflect the more concrete and detailed information required at the neighborhood level. Actually, the "design ideas" are derived from Christopher Alexander's Pattern Language, which investigates all levels of building activity from the cityscape to the doorstep detail in descriptive principles or patterns. Here "design ideas" are present as principles about buildings and neighborhoods which include both morphological and functional considerations. Taken as design principles, they show the detailed, specific ideas that are generated by laypersons who see details at the expense of the overall considerations. In the development of the neighborhood

plan, the Elliot Park community generated a list of these ideas (see Figure 4-9). Several detailed examples are seen in Figure 4-10 and 4-11. They are noted as follows: intersections at rightangles, redistribution of traffic on housing streets, streets as rooms, and streets with trees.

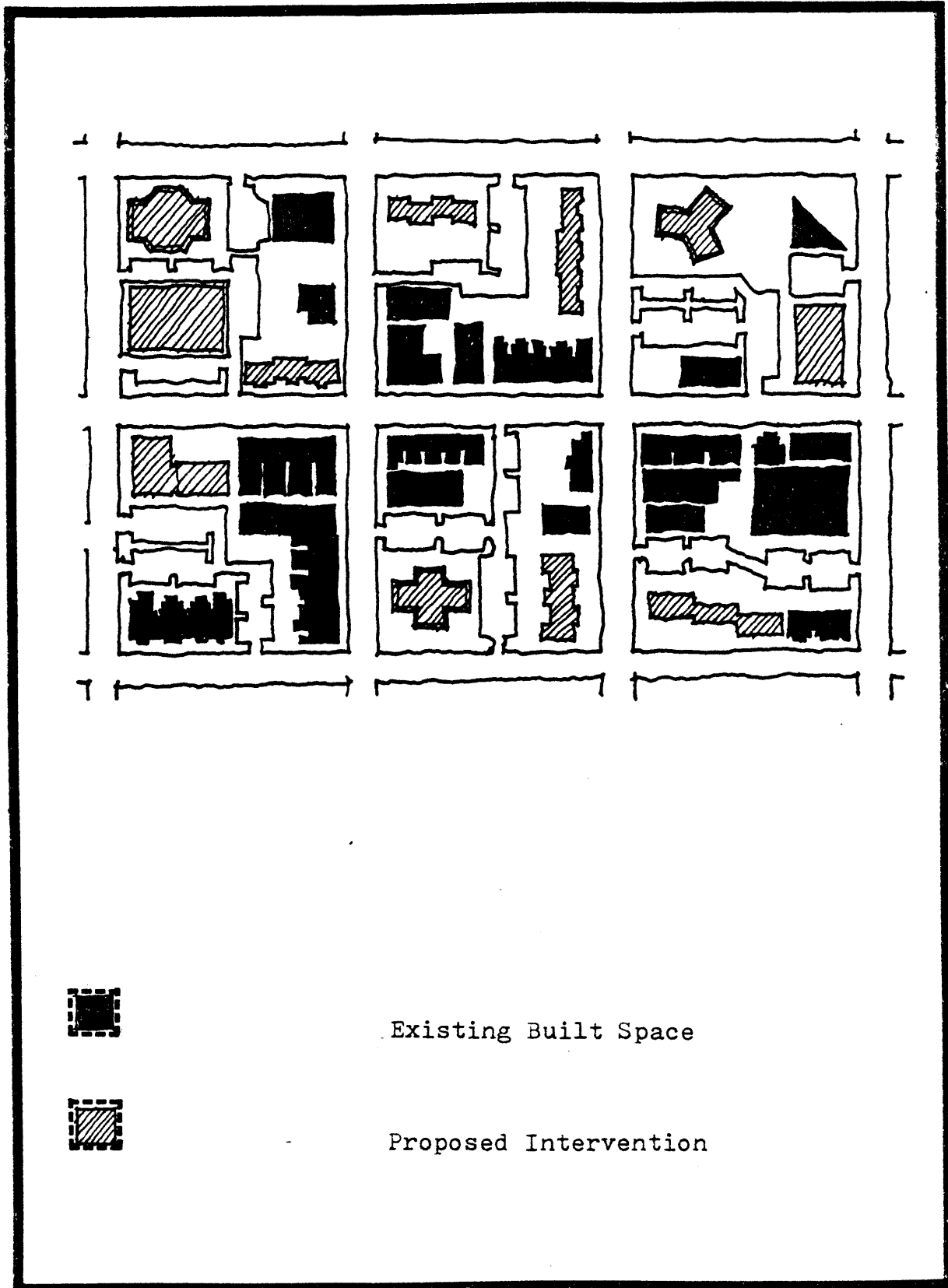

Figure 4-8

PART III

IDEAS BEHIND THE SOLUTIONS

Each of the plans is different, yet there is a set of common ideas which underlies all of them. These are ideas about what makes a building, a neighborhood, and a city a good place to live. A summary of these ideas gives the neighborhood residents a thorough explanation of the thoughts behind our plans. Whereas the plans deal specifically with buildings and places along Chicago Avenue, these ideas deal with principles (that apply to any inner-city neighborhood). In this way, they can be used as guidelines by which the neighborhood can evaluate proposed development.

This set of ideas evolved from working with the residents and from our own observation and professional education. They explain conditions that are needed in order to create a healthy environment. Each idea is explained in terms of the particular problem it solves and why it is important. Each idea is presented as an individual recommendation, but in reality, the ideas are not separable from one another. At the end of each recommendation, the other ideas are referred to that are closely related. Examples from the plans that illustrate the application of a recommendation are also included.

Planning Ideas:

1. Intersections at right angles
2. Restricted traffic on housing streets
3. The street as a room
4. Streets with trees
5. Entrances facing the street
6. Homes which overlook the street
7. Low-rise buildings
8. Shared yards, patios, and courtyards
9. Private outdoor space for each unit
10. Southern sun and natural ventilation
11. Sidewalks and alleys
12. Life for the interior of the block
13. Scattered parking
14. Commercial/residential mix
15. Neighborhood shopping area
16. Shared commercial parking
17. Small specialized stores
18. Window shopping
19. Central gathering place
20. Community programs
21. Evening activity
22. Neighborhood recreation center
23. Community garden
24. Freeway edges.

Figure 4-9

INTERSECTIONS AT RIGHT ANGLES #1

Streets that come together at angles other than 90 degrees are often confusing and unsafe. It is difficult to remedy the matter by signs or signals that control traffic. Such intersections are usually very wide and thus difficult for the pedestrian to cross.

It is recommended that streets should come together as close to 90 degrees as possible. Pedestrian walks should be clearly marked. The pedestrian should not have to walk more than the actual width of the traffic lanes to cross the street. In no case should that distance be more than 50 feet.

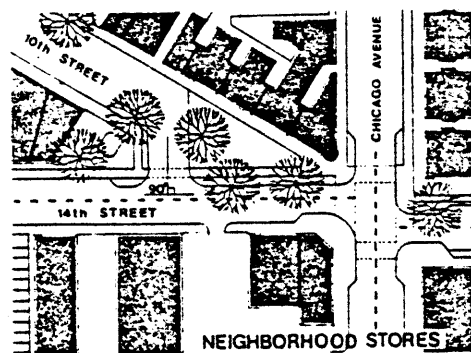

#1

Plan 1

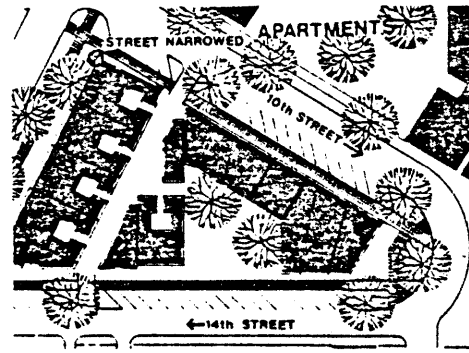

#2

Composite Plan

RESTRICTED TRAFFIC ON HOUSING STREETS #2

Traffic on housing streets is often too heavy and fast. This is dangerous for children and pets and unpleasant for others. As a result, people do not consider the street an asset to their neighborhood. The street becomes the domain of the speeding motorist and the people who live there feel that they have no control over the activities on the street. Housing streets should be quiet and pleasant places.

It is recommended that through traffic should be discouraged on residential sidestreets. This can be done by narrowing the streets in order to restrict traffic. Sidewalks could be extended at the intersections to make it easier and safer for people to cross. The street pavement could be raised to sidewalk level at crosswalks, and the crosswalks could be paved with a different material to emphasize that this area belongs to the pedestrian.

See: STREETS WITH TREES #4, THE STREET AS A ROOM #3, SCATTERED PARKING #13.

THE STREET AS A ROOM #3

A residential street should be a common space that is used and enjoyed by the people who live there. However, many residential streets are dominated by the automobile, making them an unpleasant place that the residents have little to do with.

It is recommended that residential streets be thought of as community rooms, where people can meet their neighbors, read the paper, or walk the dog. Improvements could include trees that make a ceiling, interesting pavement for the floor, places for flowers, grass, street furniture and low scale lighting fixtures. Designing residential streets in this way, for people rather than cars, encourages the residents to feel that their street really belongs to them.

See: STREETS WITH TREES #4, ENTRANCES FACING THE STREET #5, HOMES WHICH OVERLOOK THE STREET #6, LOW-RISE BUILDINGS #7.

STREETS WITH TREES #4

Streets without trees are barren and are not pleasant places to live. There is nothing between the front of one house and the house across the street except for parked cars and passing traffic.

It is recommended that trees be planted on both sides of residential streets. Besides separating the street space from the front yards, the trees would one day form a canopy over the street and provide shade and privacy for the homes.

See: THE STREET AS A ROOM #3

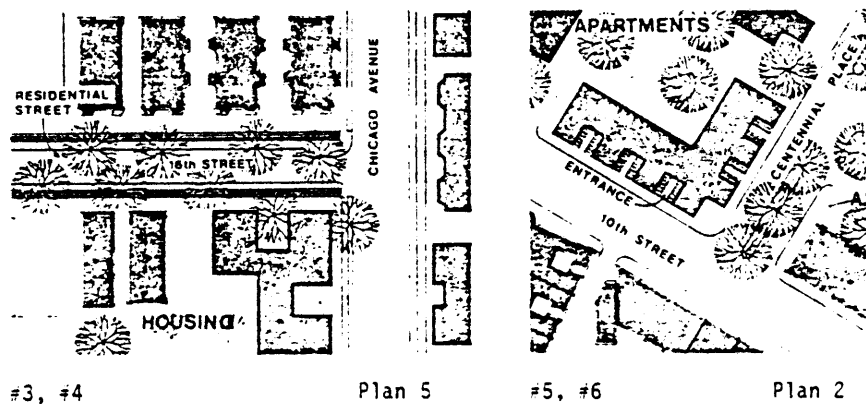

ENTRANCES FACING THE STREET #5

The street on which one lives can be thought of as an extension of the home.

Figure 4-11

An effort to present these ideas within a context occurred in the Elliot Park Neighborhood's Chicago Avenue study. This study proposes a diversity of housing types with notable Radiant City interventions as indiscriminant violations of the Block City model. The organization is arbitrary, as reflected in the traffic circle and undulating facades. The design ideas require a greater district organizational structure to give them consistency and coherence (see Figures 4-12 and 4-13).

Level 5 activity, unlike the previous levels, engages the architect rather than the urban designer. Here the architect works in his conventional role of organizing a client's program on a site. It is here that preconceived, site-specific professional models are most commonly imposed on existing contexts. It is an easy thing to do as there are no guidelines addressing neighborhood and district concerns, much less a review process which permits their expression in public form.

Hence, the architect works directly with the professionals at Level 2, and the context is ignored. In this example, the Radiant City, Harvard Married Student Dorm is imposed upon the existing fabric of South Cambridge (see Figure 4-14).

Level 6 also shows a conventional role of architectural activity in designing interior space organization, i.e. rooms, for imagined users and their activities. Generally this is an internal dialogue between the architect and his client and has only indirect bearing on the neighborhood quality (see Figure 4-15).

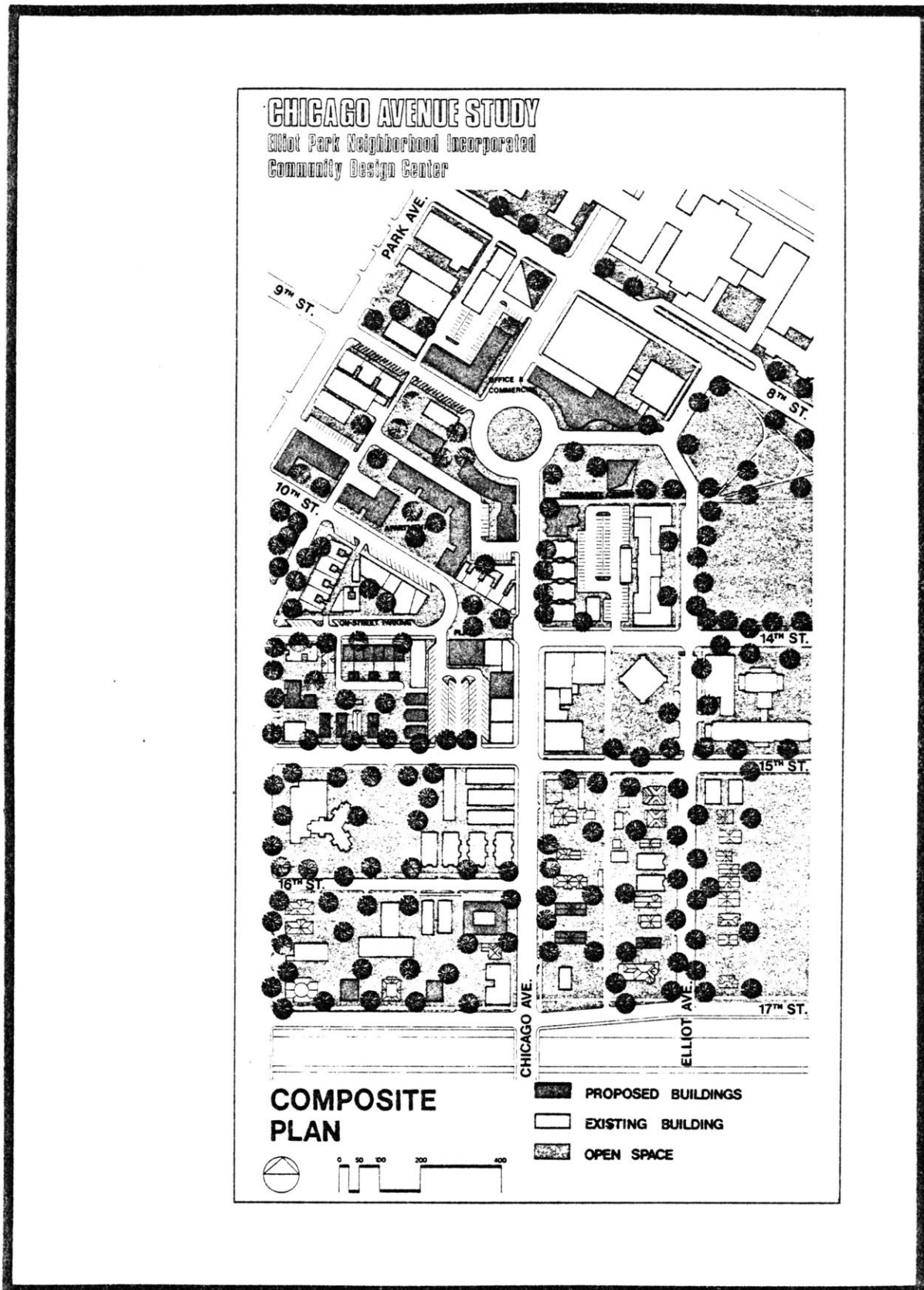

Figure 4-12

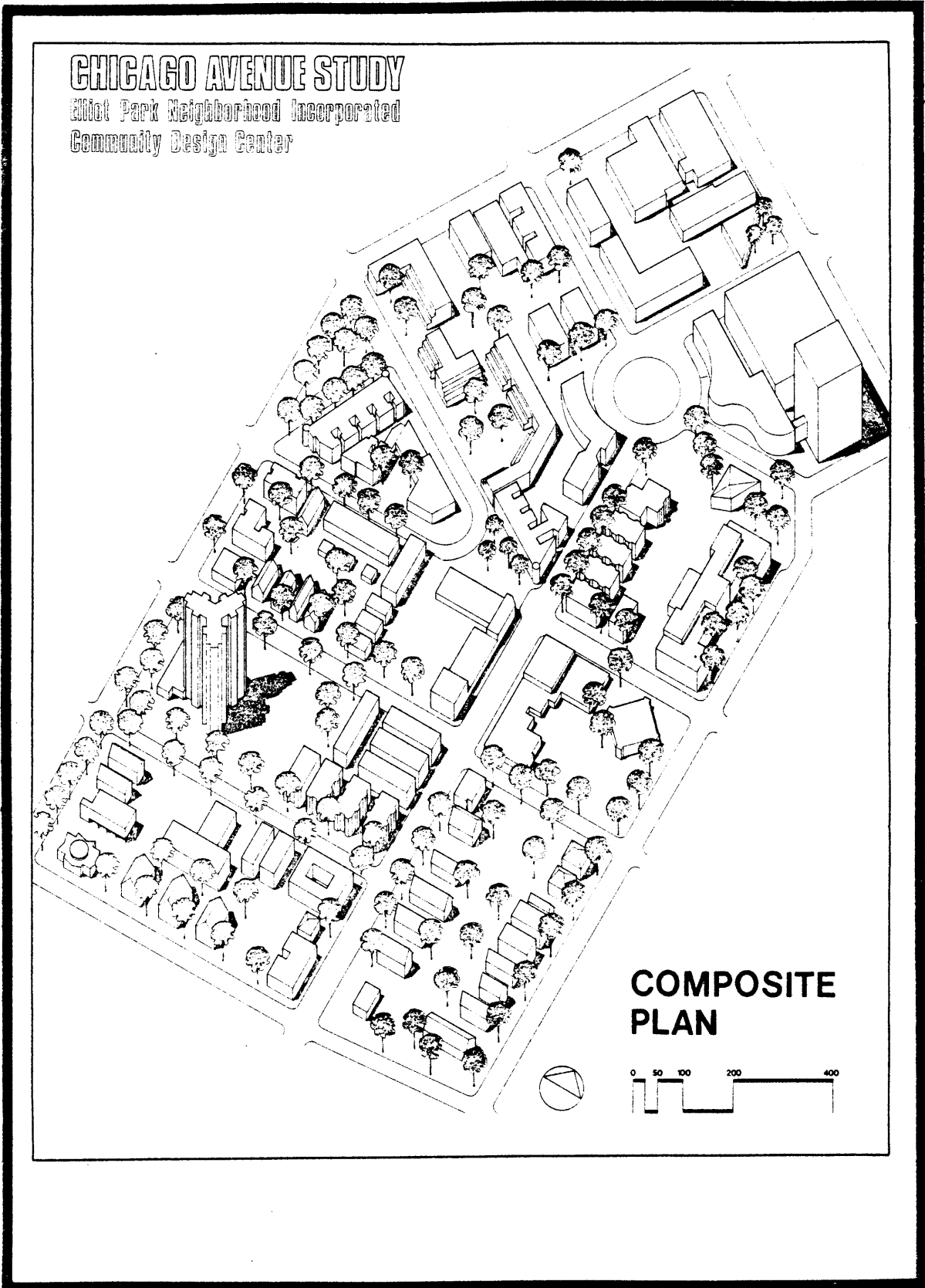

Figure 4-13

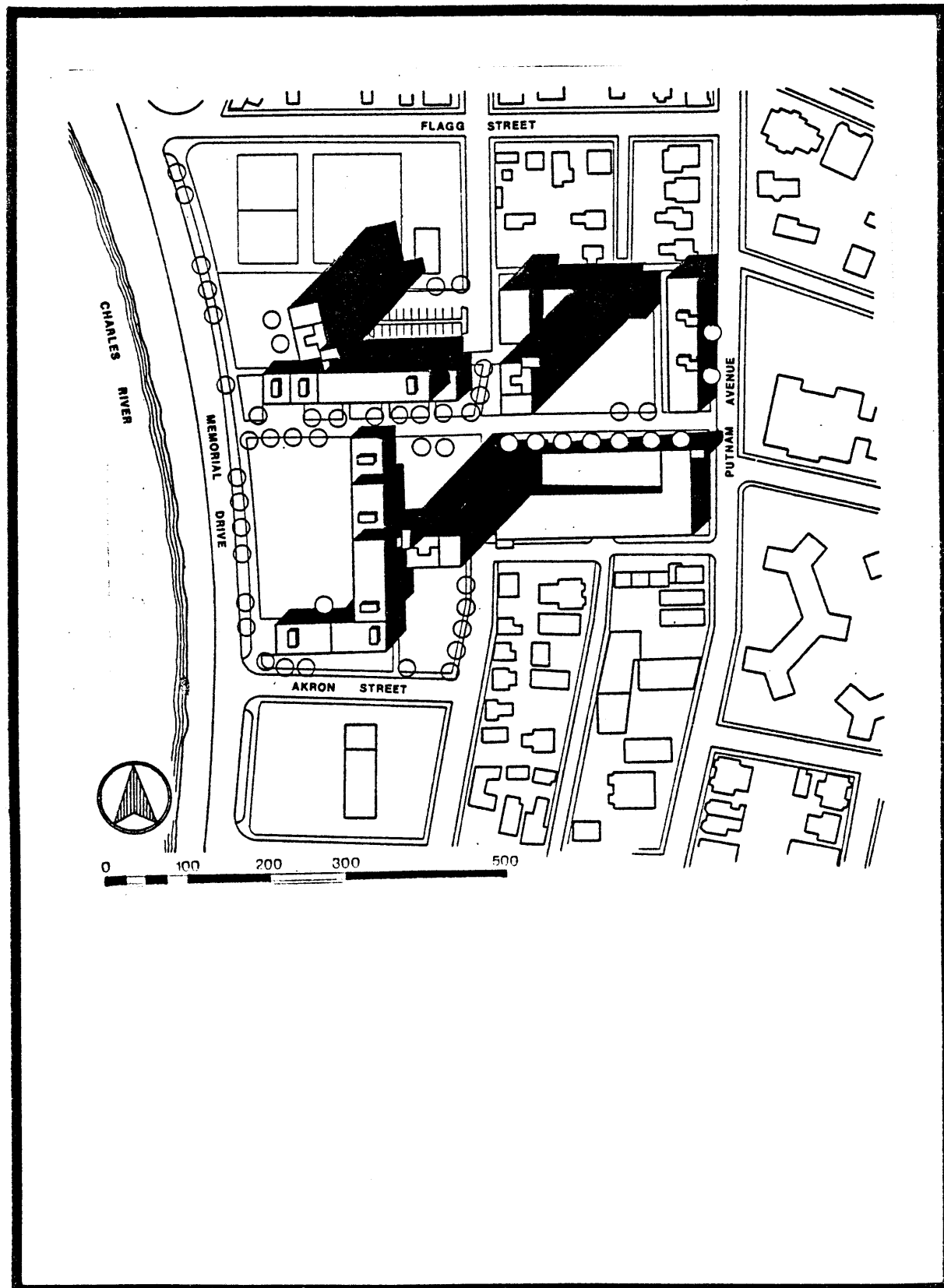

Figure 4-14

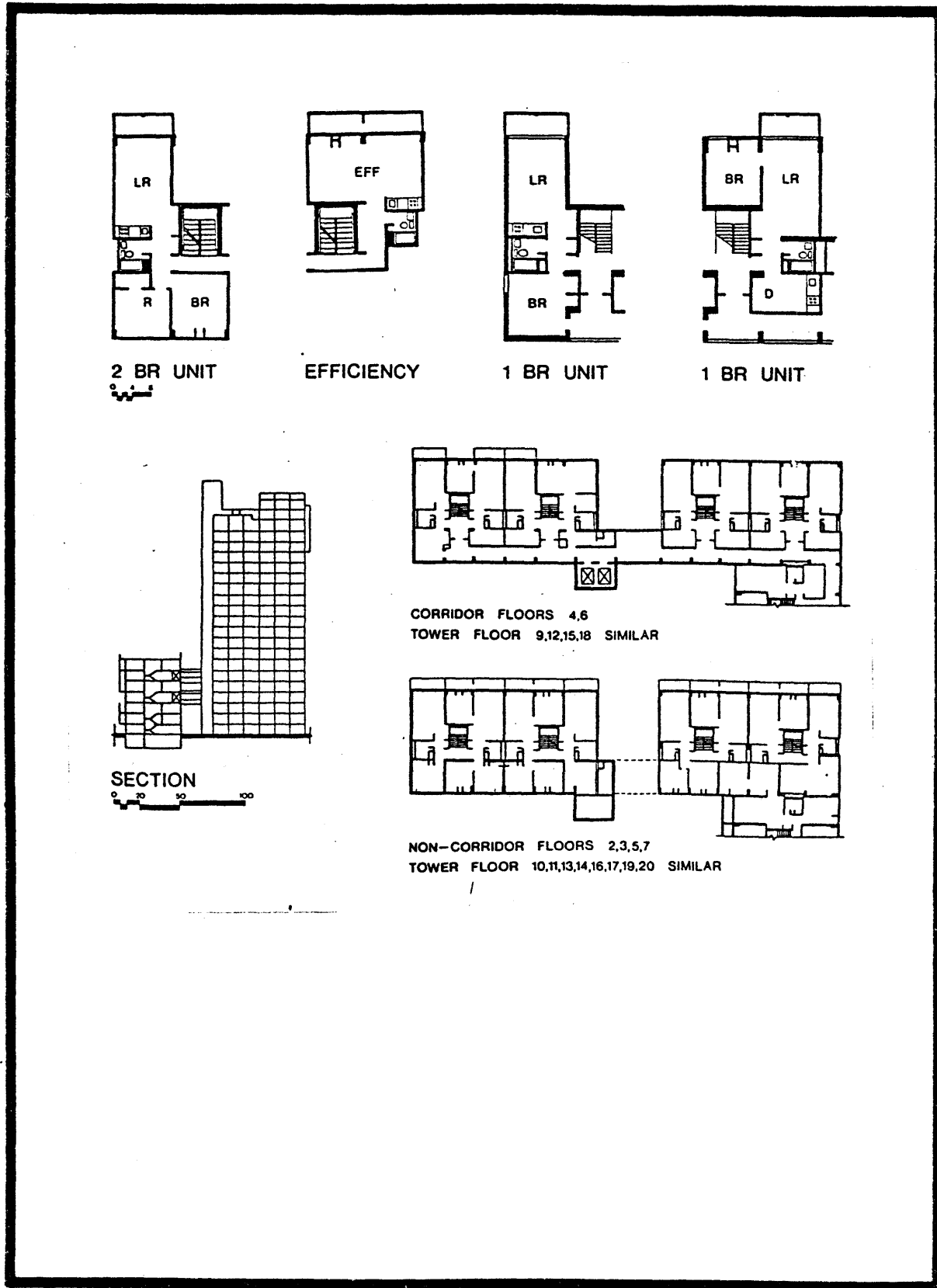

Figure 4-15

Given this brief survey of the documentation found at the six levels of physical planning, how can one develop a method that combines the broader goals of city form and legibility while reflecting contextual sensitivity without compromising the individual requirements of the land parcel owner?

Such a method must emphasize the planning activity at Levels 3 and 4 in preparation for working with professionals and specialists on Level 5. It must involve citizens in the process of design and planning with a method that is comprehensible to laity and professionals alike. It must be a method that allows citizens to voice choices freely.

First, let us review again the reasons why the Level 2 and 5 relationships fail to provide sensitive intervention into existing contexts. The reasons were the following: the control of land-use decisions is too centralized at Level 2; the regulation required by land-use decision at Level 2 is too coarse to be sympathetic with existing context; and the documentation format necessary to identify appropriate Level 3 and Level 4 doesn't exist.

There are many possible methodologies to remedy this situation. One would have to first of all identify the appropriate issues of concern for each power level and then prepare documentations which would address three specific issues.

For our purposes, the appropriate area of control for each level might be as follows:

<u>Power</u>	<u>Controls</u>	<u>Documents</u>
Level 2	City Land Use Zoning Law District/Performance	Land Use Map Zoning Codes
Level 3	District Land Use Built and Open Space Regulations within the Zoning Code Requirements	B Analysis O Analysis B Guidelines O Guidelines
Level 4	Neighborhood Street- scape	Pathway Diagrams Relating to Appropriate Issues of Concern
Level 5	Parcel Development- Improvement (Building)	Site Plan Floor Plan

Our design guidelines would emphasize only Levels 3 and 4 and would present a vehicle to make existing zoning laws more responsive to community defined contextual considerations. The guidelines would provide a natural refinement of physical planning issues from Level 2 to Level 5 (see Figure 4-16). They would not, however, be legally mandated.

The procedure and documentation would be as follows:

Level 3: District Guidelines

1. Statement of visual goals for district based on city urban design plan.
2. Documentation which analyzes the structure of the existing morphology using the B,O, OB space paradigm of Chapter 2.

Level 4: Neighborhood Guidelines

1. Statement of visual goals for a specific neighborhood.

2. Documentation which analyzes existing context with the use of the pathway diagram which is centered on the observer as he walks through the environment. The pathway diagram would consolidate the issues that the community felt would be most important in preserving contextual continuity.

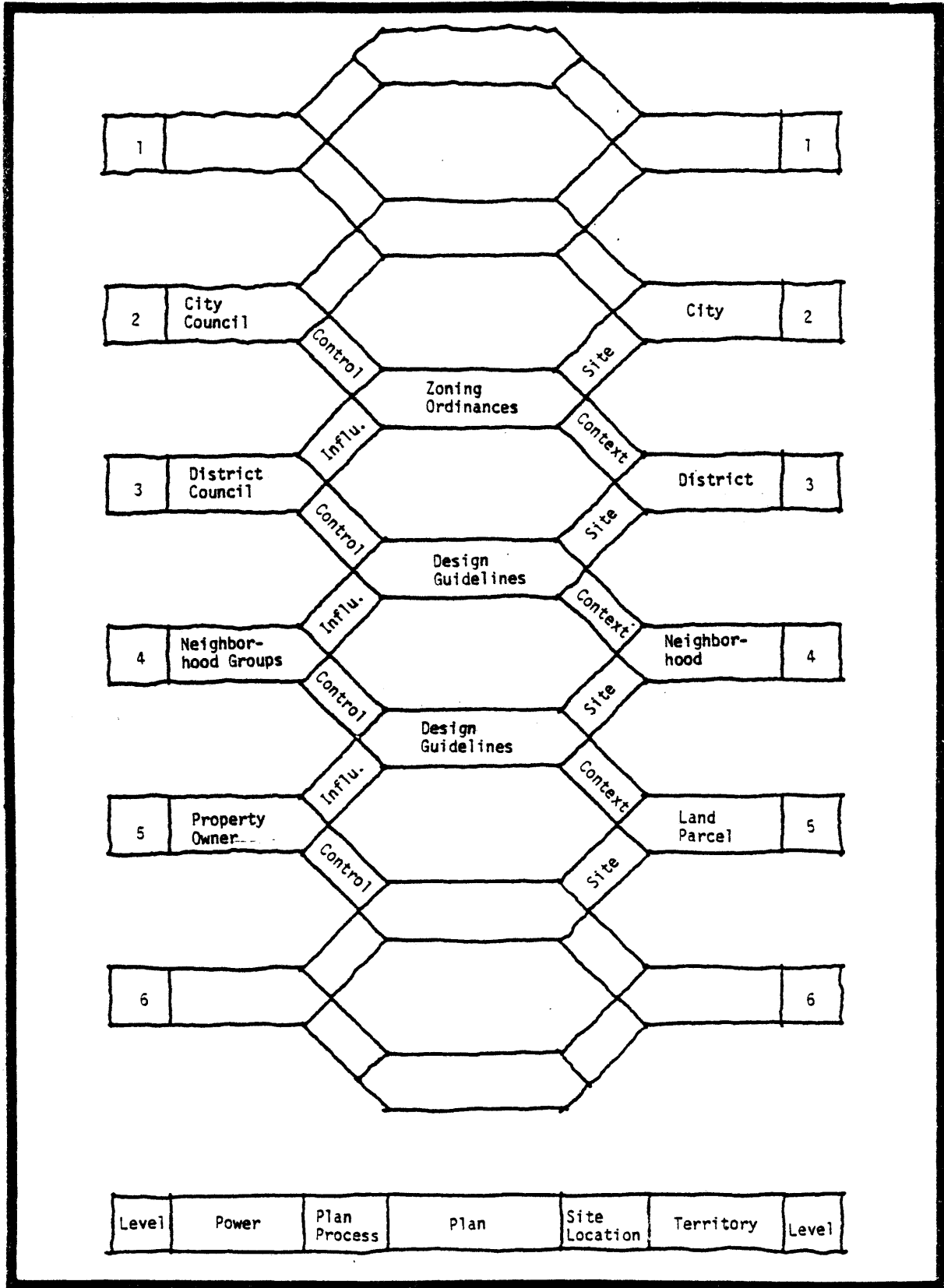

Figure 4-16

The guideline format is simple and direct. We have seen the method before in the analytical documentation in Chapter 2. But how would a process be constructed using the design guidelines as developed for Levels 3 and 4 to give guidance to a developer/architect seeking to build on a given parcel? It might happen as follows:

- Step 1: Review anticipated building project history, design intent, and so on.
- Step 2: Prepare district design guidelines, documenting existing morphological setting.
- Step 3: Prepare neighborhood guidelines defining neighborhood perceptual concerns via the use of the pathway diagram.
- Step 4: Analyze the proposed program for the planning effort. This analysis would include the review of the appropriate zoning requirements for the given site.
- Step 5: Prepare design guidelines for developer/architect. Level 3--District Level and Level 4--Neighborhood Level.

The material consolidated in Step 5 would constitute the guidelines for the given parcel, as an effort to influence Level 5 physical planning.

It is important to note that such a process can be used in a variety of ways. The techniques are simple and can be done without a great deal of professional assistance. To demonstrate how guidelines can function, we will look at a typical city, Minneapolis, Minnesota, and an urban neighborhood within that city called Elliot Park in Part Three.

Part III

In Part III, we will briefly study an urban neighborhood in Minneapolis, Minnesota, named Elliot Park, which is confronted with development pressure. Within this neighborhood we will demonstrate our guideline structure in three development scenarios to show how a neighborhood could work to strengthen what it perceives as desirable morphological qualities of its environment.

The scenario issues are as follows: Chapter 6, Augustana Nursing home, amelioration of medium density housing scale; Chapter 7, the Ninth Street Greenway, relocation of existing historically significant housing to promote a special design district; Chapter 8, Elliot Park East, initiation of new mixed uses adjacent to Elliot Park.

Chapter 5

Minneapolis and Elliot Park

The Prairie city of Minneapolis has a population of 400,000 within a metropolitan area of 2.3 million; it is typical of many Midwestern cities in central United States. Located along the Mississippi River, its early transportation source, Minneapolis was founded in 1850 and served as a lumber and milling center throughout the remainder of the 19th century. In the 20th century, it became a corporate center for these same industries, as well as a center for newer merchandising and electronic industries. The leaders of these corporations, acting through the Downtown Council, provide the nationally recognized private sector initiative for the city's physical development.

Like many prairie cities, Minneapolis is a commuter city. Its CBD lies in a concentrated, 12 block area surrounded by parking lots that store the cars for 50% of the commuters. The remaining commuters travel by surface mass transit--diesel driven buses. Beyond the sea of parking lots lie the older, single and multi-family inner-city neighborhoods whose dwellings are wood-framed with high, pitched roofs (see Figure 5-1 and 5-2). The more elite inner-city neighborhoods surround the large lakes to the southwest and west, forming the basis of the city's famous parkway system.

Historically, Minneapolis has always depended on wheeled traffic. Its streets are wide, and the layout is a uniform gridiron. Because of its relatively recent origin, the city has never developed medium density housing. Row housing common to the immigration centers in

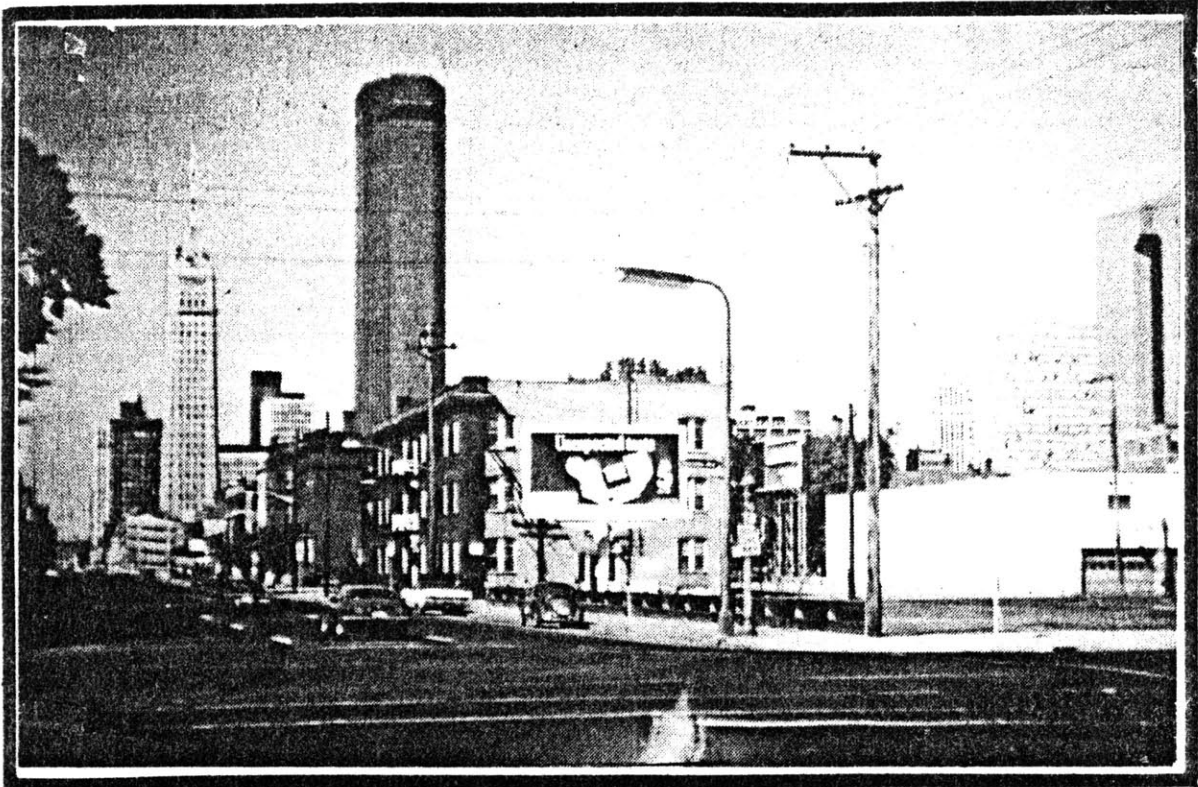

Figure 5-1

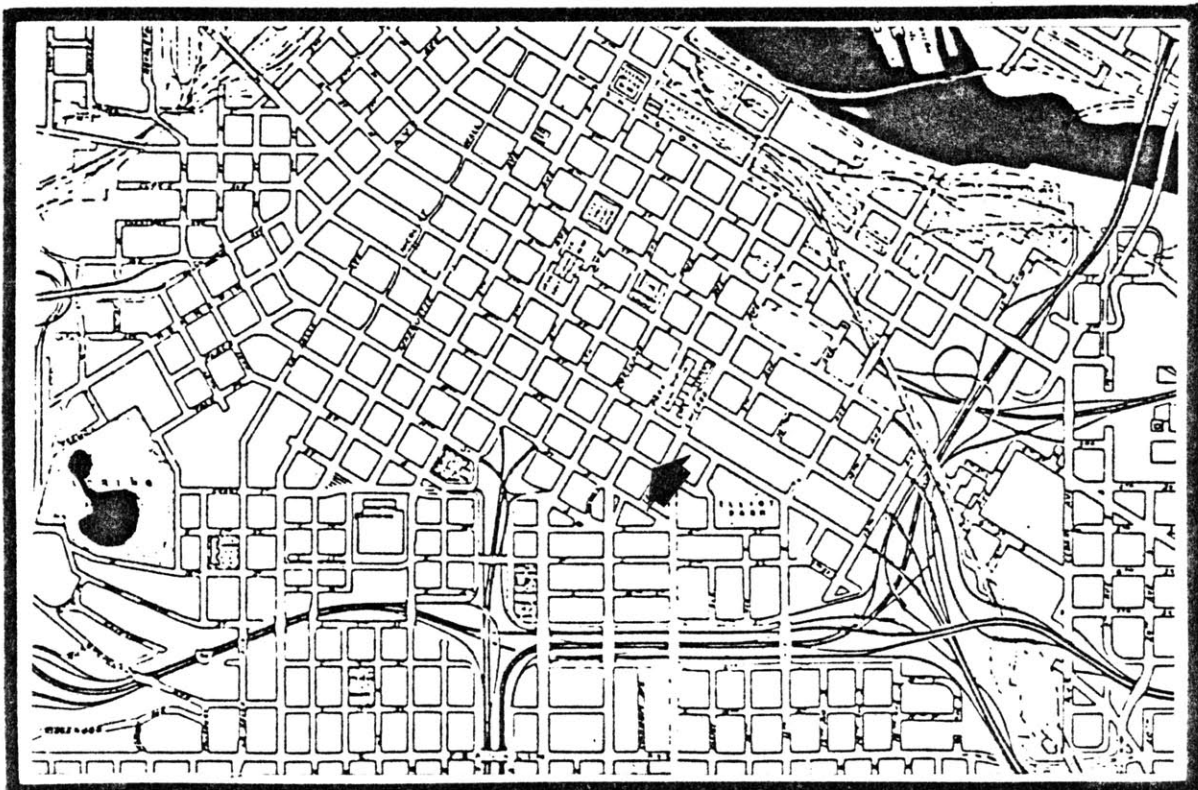

Figure 5-2

the Eastern seaports and industrial cities are found only on occasion, mixed among single family housing in the older neighborhoods.

Despite the city's totally Midwestern organization structure, many of its Eastern trained architectural professionals have looked to the architects from Eastern cities for professional leadership and urban development models, rather than base their development models on the unique characteristics of the area. Like other cities, Minneapolis followed national urban policy and engaged in enthusiastic demolition during the urban renewal era of the fifties and sixties. Looking at Minneapolis now, one sees the destruction from this period still present in undeveloped inner-city land.

The first urban renewal district, the Gateway Center, was planned in the city's original historic business district along the Mississippi River (see Figure 5-3). The development was an effort to attract inner-city corporations bound for the suburbs to inexpensive building sites, as well as to attract the middle class to high-rise apartment life styles similar to their Eastern city counterparts. In the process of renewal, many of the fine older masonry commercial buildings were demolished. Later the area received a new public library, several corporate offices and a high-rise apartment complex, all mixed among countless parking lots. The recent demolition of the large, Romanesque railroad station, built in 1906, leaves the historic center of the city with its oldest building the Depression-era post office built in 1938.

As the city's Gateway urban renewal district languished during the post-war years, shopping centers blossomed in the suburbs. To

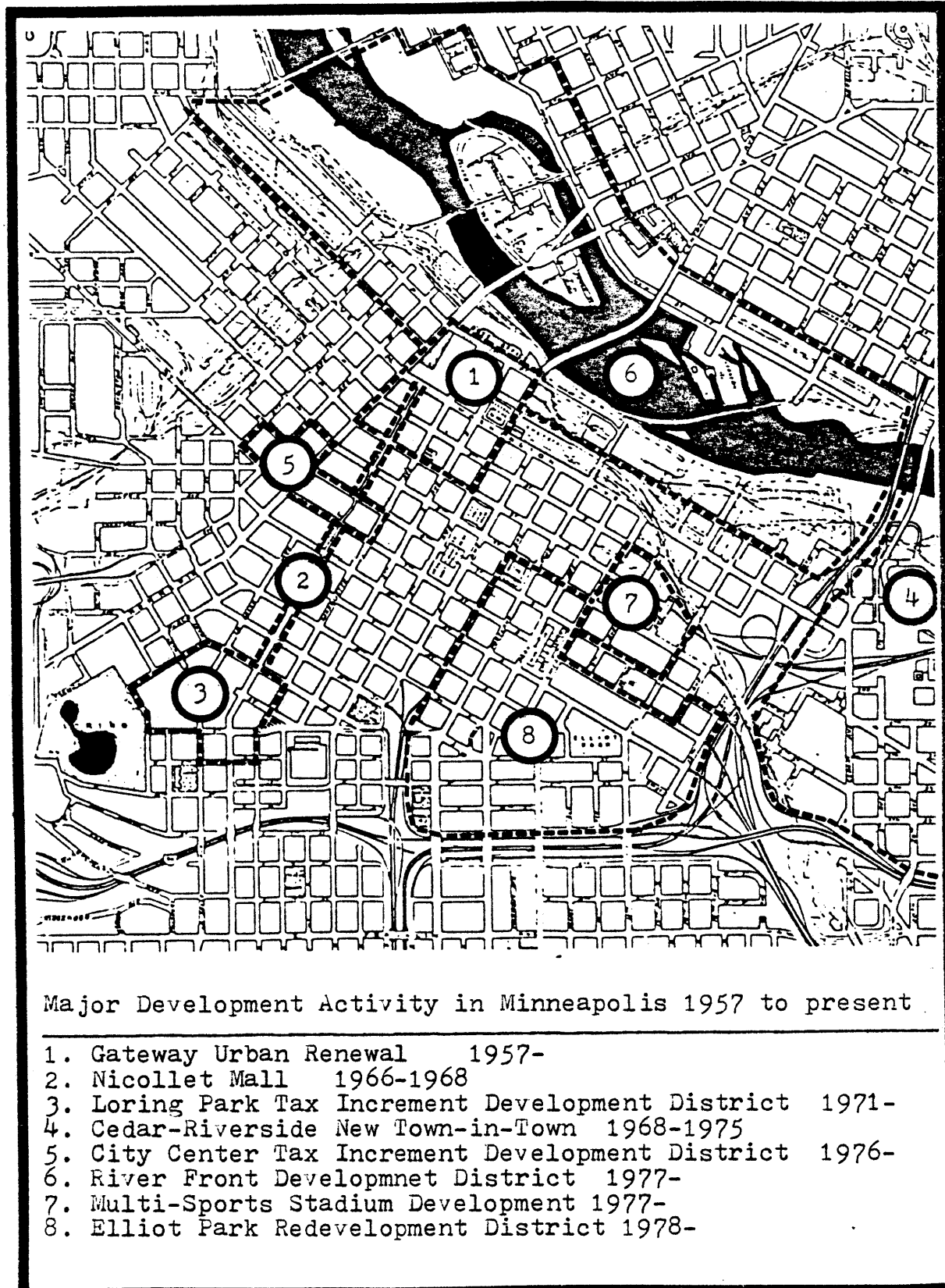

Figure 5-3

rekindle interest in the CBD in the middle sixties, the Downtown Council, the powerful downtown business-people's association, planned and executed a radical project for the time, a pedestrian shopping mall on Nicollet Avenue, which was patterned after the successful suburban shopping malls. Finished in 1968, it was an immediate success and has been subsequently used as a model for other cities throughout the country.

Completion of the mall failed to overcome the effects of single use zoning, since the commuting shoppers who were active on the mall by day returned to their homes in the suburbs by early evening. To remedy this situation, the Downtown Council sought to provide housing for the upper middle class in the Loring Park area. The project was to focus on a greenway extension of the Nicollet Mall; its visual image was to be a neighborhood of high and mid-rise apartment buildings. The area, located in the heart of the city's cultural institutions, suggested a lifestyle similar to mid-Manhattan. Demolition for this tax increment development district started in 1971. But it was slow being built because of the oil crisis in 1976. Now, with several projects completed and new ones under construction, the development takes on a Garden-Radiant City image independent of its context and without internal cohesion (see Loring Park Development District, Chapter 3).

In 1973 the Downtown Council promoted a larger tax increment district to be located in the CBD. The new "City Center" development required one hundred million dollars in commercial construction which would provide a new home office building for the state's largest

bank, space for two new department stores, one replacing an existing store adjacent to the district. Word of this development caused several corporate offices to build their own buildings, some presently under construction, in order to capture the market for office space, before the municipally supported tax increment district could proceed (see Figures 5-3 and 5-4).

Along the Mississippi River corridor, other planning efforts created the 100 acre Riverfront Development District, which, in accordance with the city's comprehensive plan, would provide for three new communities along the river. Two would be on old industrial sites on the west bank of the river, a third would be an old-town on the east bank that would recreate St. Anthony village, the river settlement preceded Minneapolis (see Figure 5-3).

These communities were planned while private and institutional investors, in an effort to attract new residents to the city, financed the Cedar-Riverside new-town-in-town just south of the CBD on the west bank of the University of Minnesota campus. The new town, created by the New Communities Act of 1970, was an effort to bring 20,000 people into the area in high density environments over a period of twenty years. After the first phase was built, the project developed financial difficulties resulting from an environmental lawsuit that held up the construction of the second phase. The project was effectively terminated with HUD's foreclosure on the developer in 1977 and the subsequent announcement by HUD of the abandonment of the new communities program.

Adjacent to the Cedar-Riverside new-town and the Riverfront Development Project is the proposed site for the 55 million dollar

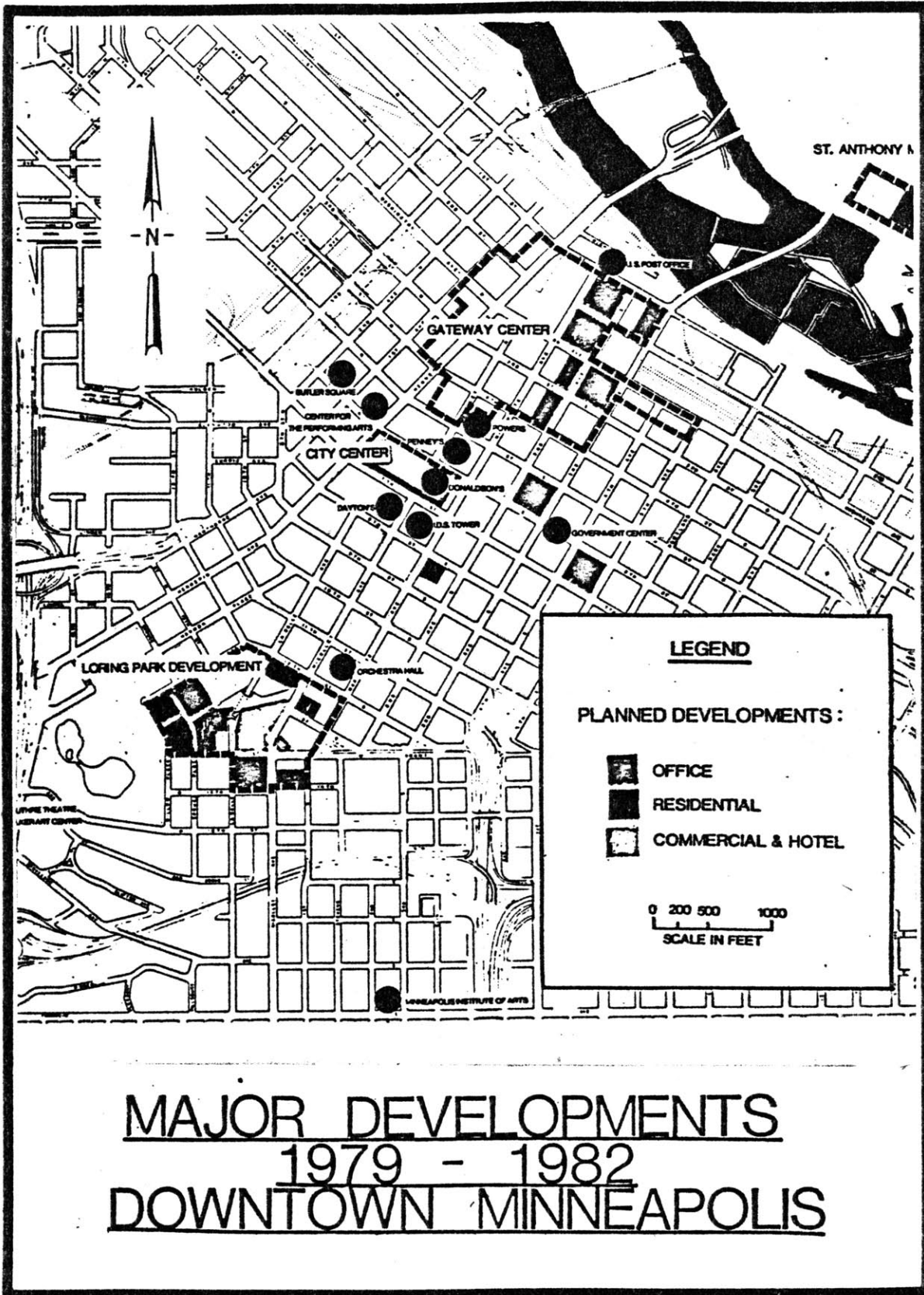

Figure 5-4

stadium to provide for the state's professional sports teams, as well as those of the University of Minnesota. The site is on the north side of the Elliot Park neighborhood and is presently being financed by Metropolitan Council revenue bonds backed by a 2% metropolitan liquor tax. This tax is presently being contested in the courts by the metropolitan liquor interest groups (see Figure 5-3).

Land use control in the city is divided. Minneapolis has a weak mayor/strong council system of government. The mayor oversees the Planning Department and is a member of the Planning Commission, the members of which he appoints. It is the Planning Commission that supervises all the changes in the city's zoning, which are then subject to Council approval. The City Council, on the other hand, oversees the activity of the HRA, whose board and executive officer are appointed by the mayor and confirmed by the Council. Daily administrative management of the city is performed by the city coordinator, who also administers the tax increment finance districts under City Council supervision. The park system is controlled by the independently elected Park Board, whose budget is allocated by the City Council. The Public Works Department, which administers street improvements, is also subject to the City Council.

The Metropolitan Land Planning Act of 1972, as passed by the state legislature, required the communities in the seven county metropolitan region of Minneapolis and St. Paul to prepare comprehensive master plans to enable land use planning at the metropolitan level to be done more efficiently (see Figure 5-5).

Within Minneapolis proper, this act lead to the organization of

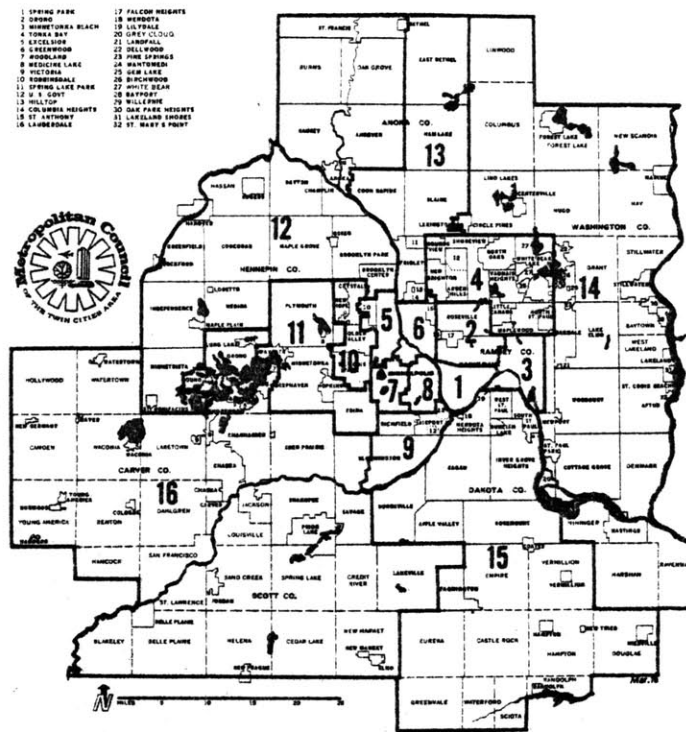

METROPOLITAN COUNCIL DISTRICTS

Figure 5-5

the city into eleven planning districts, of which the Central Planning District is one (see Figure 5-6). The planning districts align closely with the city's political wards (see Figure 5-7). The Central Community Planning District is divided into three neighborhoods: Towers, Loring Park, and Elliot Park (see Figure 5-8).

From this description it is possible to establish the levels of land use planning that occur in Minneapolis in the following diagram (see Figure 5-9). Level 1 shows the state mandate of the Metropolitan Council which governs metropolitan land use. The City Council, via state enabling legislation, has control over land use within the city at Level 2. With the Central Community Council, the Central Business District have their land use planning at Level 3, and Elliot Park within this context has its place at the neighborhood level at Level 4. The property owner at Level 5, then, is controlled by land use control, i.e. zoning, by Level 2. Our design guidelines will concentrate on Levels 3-5 as zoning regulation impacts on neighborhood environments with the action of private property owners.

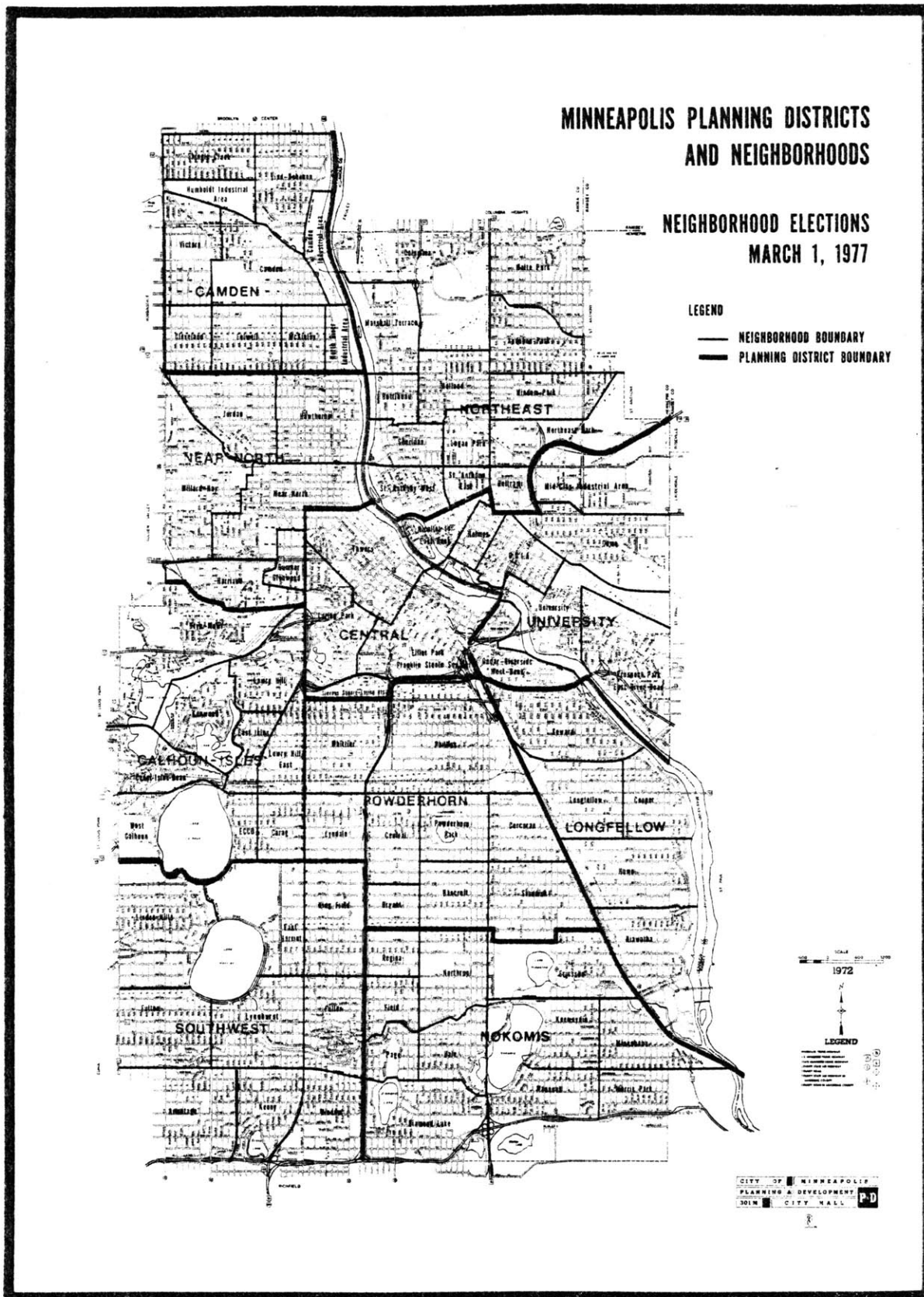

Figure 5-6

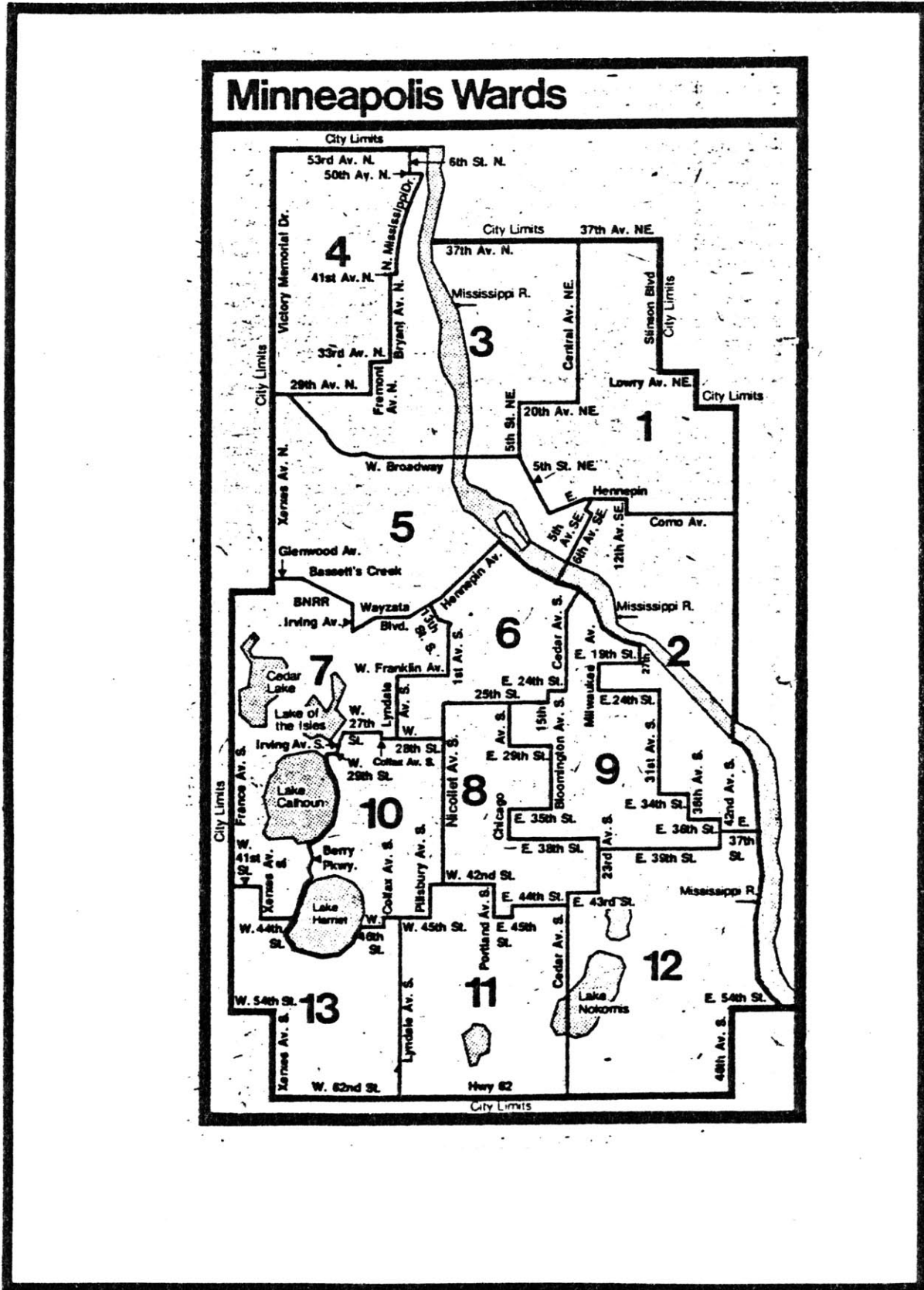

Figure 5-7

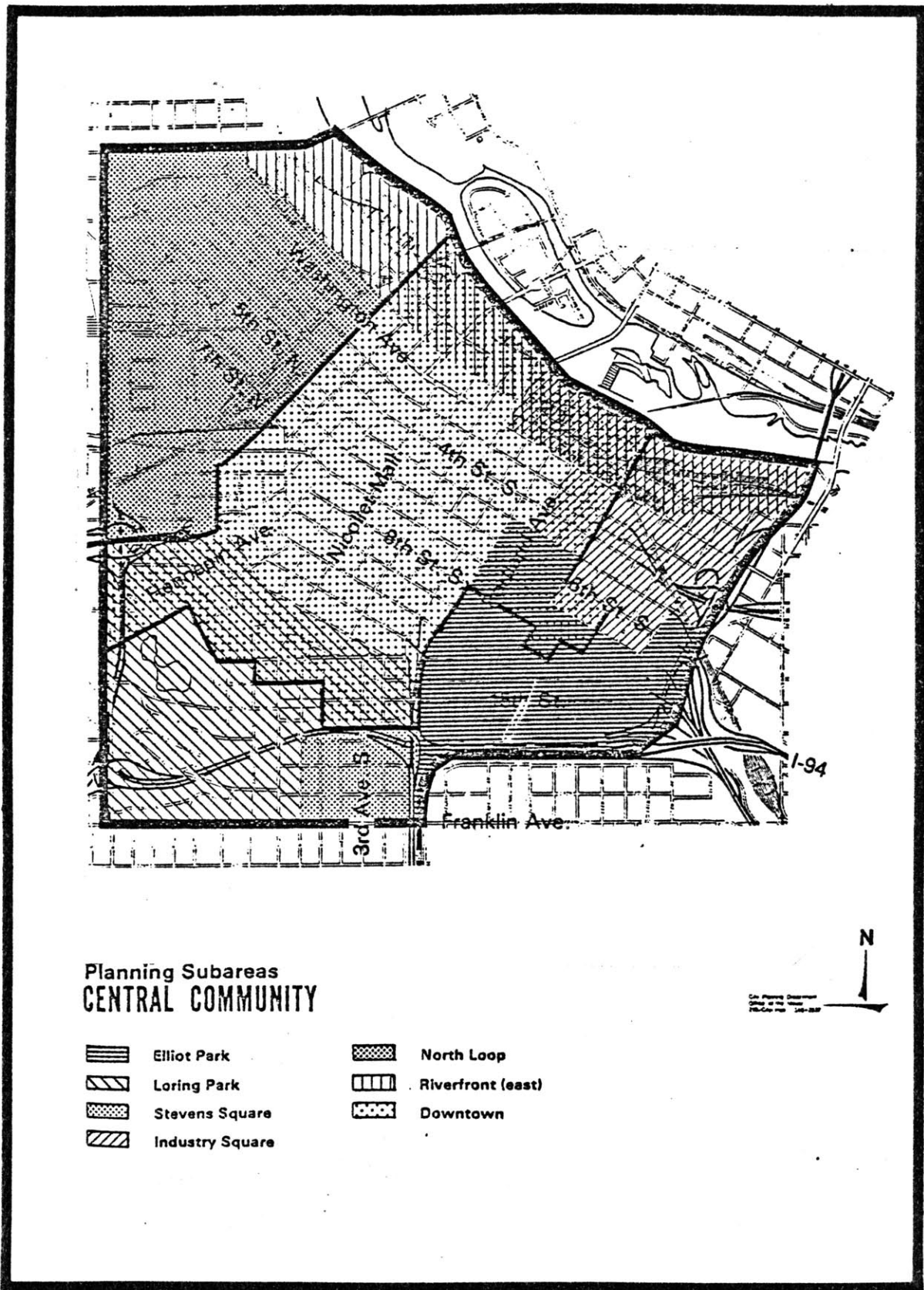

Figure 5-8

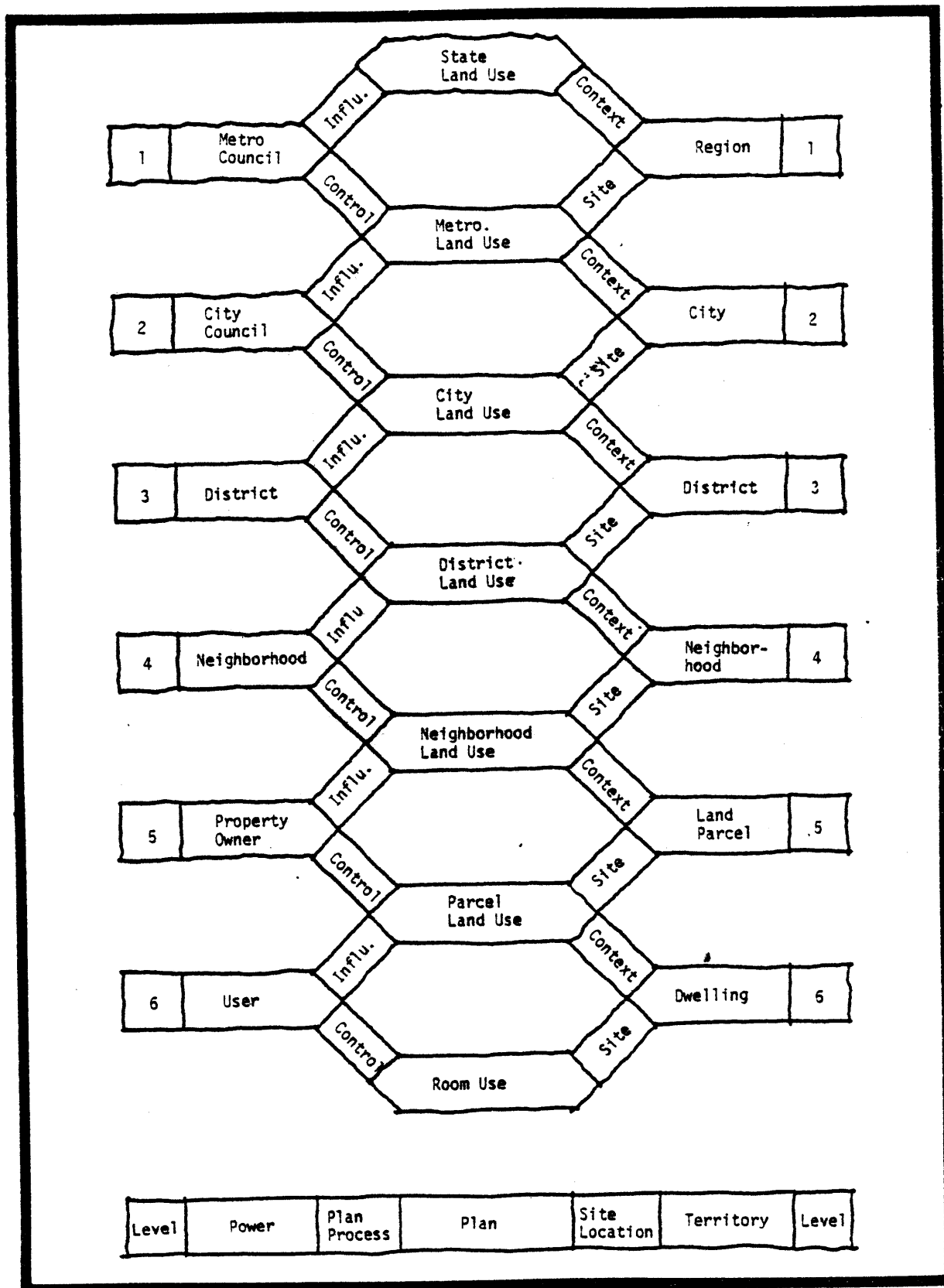

Figure 5-9

Minneapolis has a comprehensive plan, called "Metro '85." Published in 1972, Metro '85 like many comprehensive plans, was developed within the Planning staff and accepted by the Planning Commission without great public contribution or review. An examination of the plan reveals the following planning framework:

1. Land Use Framework--a functional organization of city activities supported by the city zoning code.
2. Circulation Framework--a functional organization of vehicular and pedestrian movement.
3. Visual Image Framework--a survey that organizes the city's morphology through Image of the City conceptualizations.
4. Visual Framework--a study that organizes specific districts visual sequence, street widths, street signage, landscaping, and street lighting.
5. Environmental Control Framework--a study that suggests policies for reducing air, water, and noise pollution while reducing the impact of the area's extreme climatic conditions, i.e. skyways.

Our major concern here will be parts one through four of the plan which we will describe briefly. The latter two parts are of special interest.

Part One, "Land Use Framework," is influenced by the decisions made in Parts Two, Three, and Four. The planning framework identifies major districts and the uses that should be encouraged. Projects are made illustrating these potential uses. This plan is the realization facilitated through the zoning ordinance (see Figure 5-10).

The "Circulation Framework" brings together pedestrian and vehicular (car, truck, and mass transit) movement systems. Improvements for these areas are provided by the capital improvement budgets for the Public Works Department under control of the City Council. The street and parking plan under this framework is shown in Figure 5-11. Notice that five of the eighteen major arterials leaving and entering the city pass through our study area, Elliot Park.

Part Three, "Visual Image Framework," uses the conceptual language of Image of the City. It suggests several goals for visual design:

1. There should be visual diversity among the functions of the city.
2. The visual design should reflect the functions and activities of the city.
3. The visual forms of the city should be related.
4. The visual quality should be preserved by discouraging pollution and monotony.

In presenting a visual image structure for 1985, the plan draws on the following concepts: paths, districts, open space, landmarks, nodes, edges, and gateways. The plans are presented in a diagrammatic form that is difficult to understand (see Figure 5-12 and Figure 5-13). From this plan, presumably, land use decisions are to be made. Since there are no land use zoning recommendations, capital improvements, or more prescriptive documents that stem directly from this study, one might assume that it is merely a cosmetic exercise.

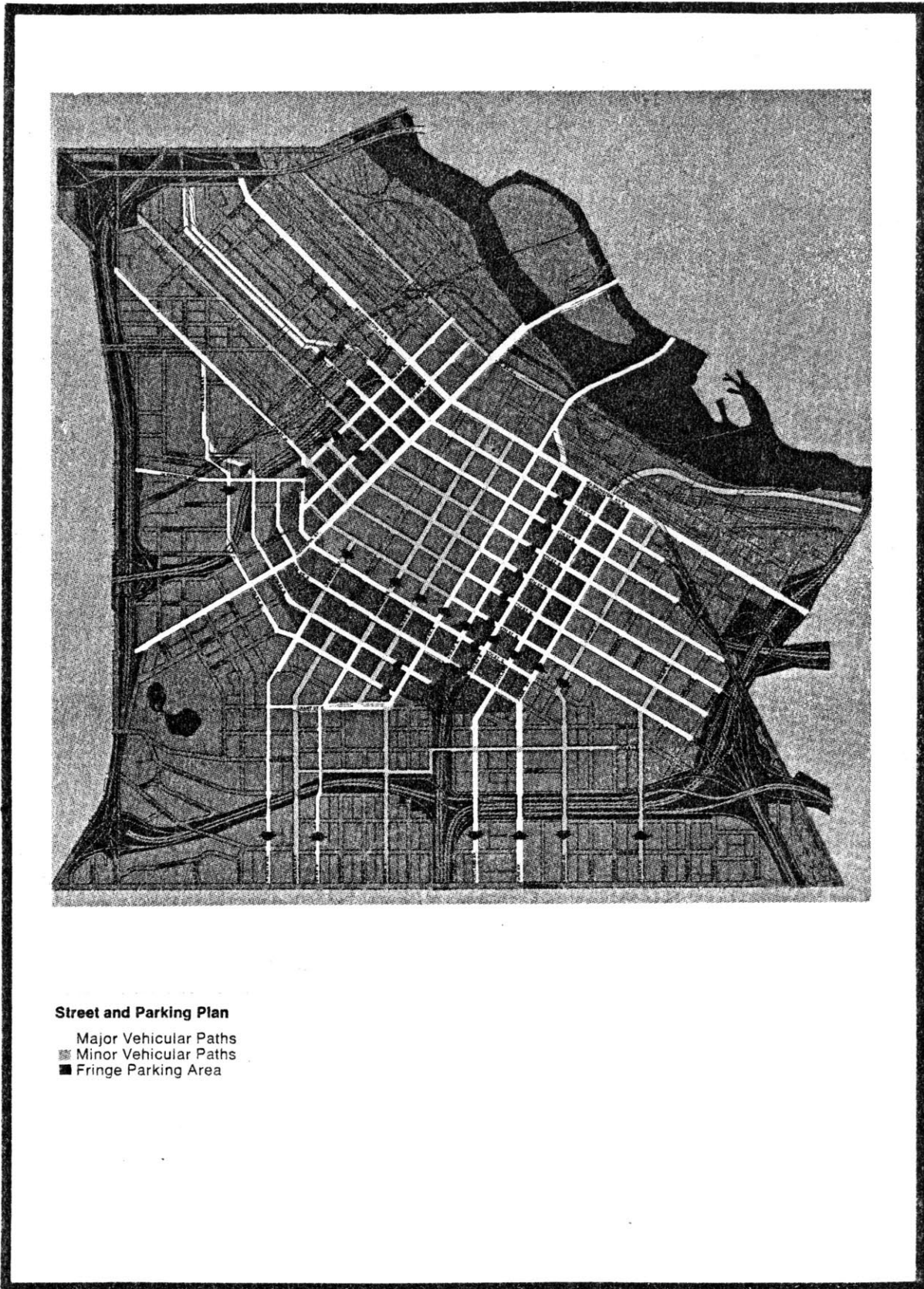

Figure 5-11

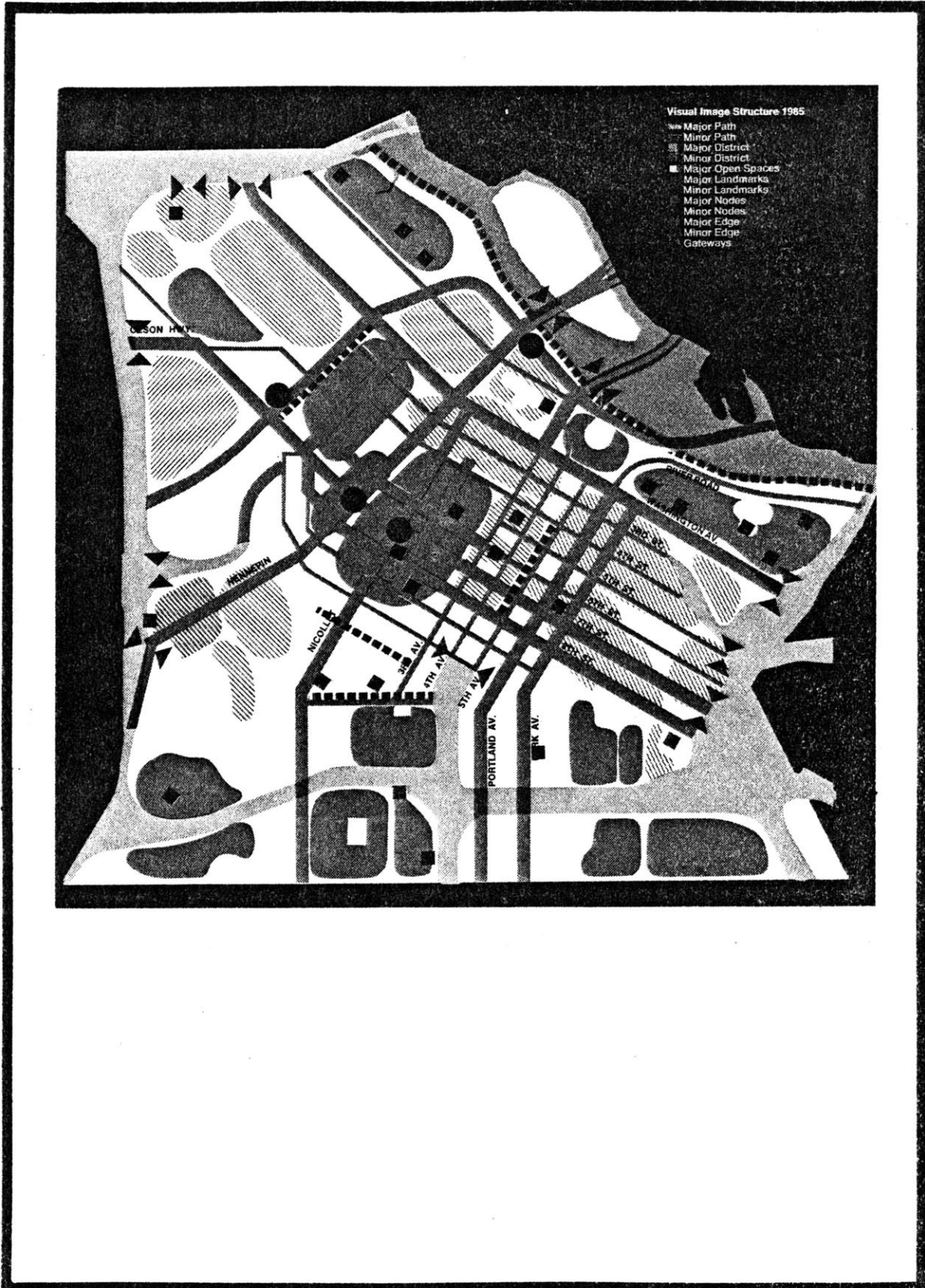

Figure 5-12

VISUAL IMAGE FRAMEWORK

The Visual Image Framework presents a number of guidelines for creating a more visually distinctive Central Minneapolis.

Paths

Major and minor paths have been designated as such either because of their relatively strategic location, traffic visibility, volume, or associated characteristics. Freeways should be considered as super-paths because of their visual dominance. Through sensitive design of lighting, landscaping, and the sense of space created by buildings and other man-made elements, it is possible to articulate a sequence of views as one travels on these paths, and to project a designed visual impression.

Paths will also occur in the pedestrian precinct, such as along Nicollet Mall and Sixth Street, above street level along the skyway routes, and below street level in tunnels and concourses. This multi-level structuring of paths may show up as a system and be visualized by some people in a three-dimensional spatial configuration.

Districts

Through zoning and design control, districts can become cohesive and harmonious in design, and certain districts can project as major parts of the public image. This should be true of the office and retail core, the cultural center, the residential neighborhoods, the entertainment area, and parts of the industrial loops.

Minor districts will become evident in areas where the land uses are somewhat mixed, but one land use predominates. This should be especially true in the hospital area, Industry Square, parts of the North Loop, and Gateway Center.

Open Spaces

Major open spaces will be dominant because they change in visual character and texture from the more densely developed areas which surround them, and because of their special uses. These spaces include the parks such as Loring, Elliot, and Riverfront, and the larger plazas such as the Civic Center and cultural center.

Landmarks

Both major and minor landmarks will emerge as the result of a number of factors — new developments, historical preservation, the imagina-

tive use of sites, improved nighttime lighting techniques, and the care given to the visibility of the skyline when viewed from the various approaches into Downtown.

As development takes place, landmarks will constantly change and new ones will be added, especially along the riverfront as part of the new housing construction. The final siting of apartment towers and any other new towers must be partly determined by considering their effect on the form of the skyline as seen from all major vantage points. Each new addition should enhance the total form and add to a balanced and exciting skyline that is sculptural in quality, and symbolizes the importance of Minneapolis.

Other Central Minneapolis landmarks will be the IDS Building, Basilica of St. Mary, City Hall, City-County Building, Foshay Tower, River Towers, Hennepin County General Hospital, and St. Joseph's Catholic Church.

Nodes

New nodes, or visual junctions, will develop at freeway interchanges, at transit stations, and possibly along the skyway network at the crossing point of the two primary systems.

Edges

The river will become a major edge through the opening up of the view to and from Downtown in a continuous sequence, rather than in fragments. Other major edges will occur along the transit lines, the freeways, the Third Avenue N. distributor, and along Grant Street where the street grid and the texture of land use changes.

Minor edges will occur along Fifth Avenue S., where the higher buildings of the Civic Center contrast with the lower buildings in the hospital and industrial areas, and along 11th Street, which is the southern boundary of the office and retail districts.

Gateways

Gateways are the major entry points into Central Minneapolis and they should be designed to reflect the change in scale from the outlying areas to Downtown. From these gateways, the skyline should be visible and the individual landmarks and the dominance of Downtown should be distinguishable.

Figure 5-13

The fourth part discusses the "Visual Form Framework," which defines its goal as the development of a cohesive city form. It defines three areas of concern:

1. The visual district prescription.
2. The skyline and building illumination plan.
3. The street design plan, including lighting, landscaping, signage, and street furniture.

The first area of concern, the "visual district prescription plan," establishes generalied goals for the districts and is identified in the visual image framework. The degree of generalization can be seen in the following prescriptions for Elliot Park:

The Elliot Park Neighborhood--This residential neighborhood can be developed generally with one or two story framehouses, three to four story low to medium rise apartment and town (row) houses. Planned development by blocks will permit the center of each block to be clear for open space and play areas. As in Loring Park, landscaping and street lighting should be in scale with neighborhood needs except for Park and Portland Avenues where trees and lights can be designed to reinforce their use as primary paths through central Minneapolis.

The "skyline and building illumination plan" hopes to give legibility to the city by nighttime illumantions (a value of the pre-energy conservation era) and by daytime through the careful placement of high-rise office towers at points were "imageability" can be improved.

The "street design plan" develops generalized goals of view sequencing, spatial framework definition, street lighting, street landscaping, signage, and street furniture.

The last part of the physical plan is the environmental quality control plan, which has two divisions: the partial climate control

systems, which plans the city's skyway system and provides design standards, and the pollution control division, which identifies policies to control air, noise, and water pollution.

To initiate the physical plan with its five components--the land use, the circulation, the visual image, the visual form, and the environmental quality frameworks--steps for implementation were taken which included zoning reform, formal designation of city design districts, the identification of historical resources, the development of design review procedures, and the development of perimeter parking facilities and second story skyways.

To date only some of the implementation actions have been taken. Some new zoning reform has occurred, as has the organization of the Riverfront Development District and the provision zoning for Planned Unit Developments (PUDS). Historical resources have been identified with a review agent for the Historical Preservation Committee. A Committee on Urban Environment has been established for design review purposes. To date, despite enabling legislation, only one special design district, Whittier East, has been legislated under the new design district legislation.

Despite the intentions of the Metro '85 plan and its partial implementation, there still exists difficulty in developing the language of visual imagery from abstract.

The discussion of "District" in Figure 5-13 shows that "through zoning and design control districts can become cohesive and harmonious in design." So far there has been little Level 2 activity other than zoning administration to develop the district controls suggested in

the visual image framework. This shortcoming is seen in the design review process in the city, with its weak mayor system of government; The City Council makes land-use decisions based on the recommendations of its technical staff, i.e. the Planning Department and the Urban Design Studio.

Design review between Levels 2,3,4, and 5 is commonly carried out by the Planning Commission. For example, in the case of a ten or more unit apartment building in a residential area, the following requirements exist in Section 434-450 in the Minneapolis zoning code (1976 edition).

1. Concept plan review by developer to neighborhood within two weeks of initial concept plan submission to the planning and development department. Neighborhood groups and property owners within 200 feet of the site are informed. (200 feet = 4 50' lots).
2. Information provided by developer and planning staff* for concept review.
 - a. site plan
 - b. 3-dimensional sketch
 - c. description of location,* topography,* utilities,* access, site changes, present neighborhood,* rental/sales price, time schedule, soil conditions.*
 - d. specification of building height, land coverage, lot size, number units, density, surrounding density,* parking provision, landscape and open space provision.
 - e. description of population served, the need for the project, and the environmental effects.
 (* items provided by the Level 2 planning staff.)
3. Procedures at concept review meeting.
 - a. developer presents Part 2 above.
 - b. planning staff presents analysis and evaluation.
4. Public hearing within 30 days after neighborhood concept review before the City Planning Commission.
5. Approval or disapproval by the Planning Commission.
6. After Planning Commission approval, final plans are reviewed by the zoning administrator for conformance to concept plan review prior to receiving building permit.

7. Action 6 can be appealed to the City Council within 15 days of the formal announcement of the decision.

This abbreviated description of the review process shows how much of the evaluative action is taken by Level 2 and its professional staff. It also shows how little emphasis is placed on contextual issues.

Thus as we discussed in the previous chapter, land use or zoning changes have always involved a dialogue between Level 5 actors (parcel owners) and Level 2 actors (the City Council). Recently, however, actions have occurred on Levels 3 and 4. The 1972 Metropolitan Comprehensive Planning Act calling for municipal comprehensive plans that were formulated by participatory process and the 1973 Community Block Grant Program has done much to encourage planning from the bottom up, i.e. actions desired in Levels 3 and 4 being realized at Level 2.

Minneapolis allocates CDBD funds through the neighborhood councils who then send elected representatives to a central planning council (see Figure 5-6) which prioritizes the CDBG proposals for City Council approval. While the CDBG process gave the communities political strength, another law, the Metropolitan Land Planning Act of 1972, gave the communities planning structure.

Consequently, there is now a basis for land-use planning at Levels 3 and 4. Elliot Park has a specific place as an urban neighborhood within the Central Community Planning District in the land-use planning hierarchy within the 6th Ward (see Figures 5-6 through 5-8). This structure has enabled us to create a reasonably accurate level diagram for the city of Minneapolis, which we have already seen in

Figure 5-9.

Given this brief discussion of the city's present development activity and land-use planning structure, let us turn our attention to our study neighborhood, Elliot Park. Located southwest of the CBD, Elliot Park is the community that surrounds the 6.9 acre park that was given to the city over 100 years ago by the Elliot family. The borders of the community are clear. To the south is I-94, which travels on to St. Paul; to the east is the I-94 freeway interchange with I-35, which takes traffic to Canada; to the north is Industry Square, an industrial park that has failed to develop and is now the site for the proposed 55,000 seat sports facility; to the west is the CBD and the border of Elliot Park at Fifth Avenue. It is the neighborhood second closest to the city center, being only nine blocks from Nicollet Mall, the center of the shopping district (see Figures 5-3 and 5-14).

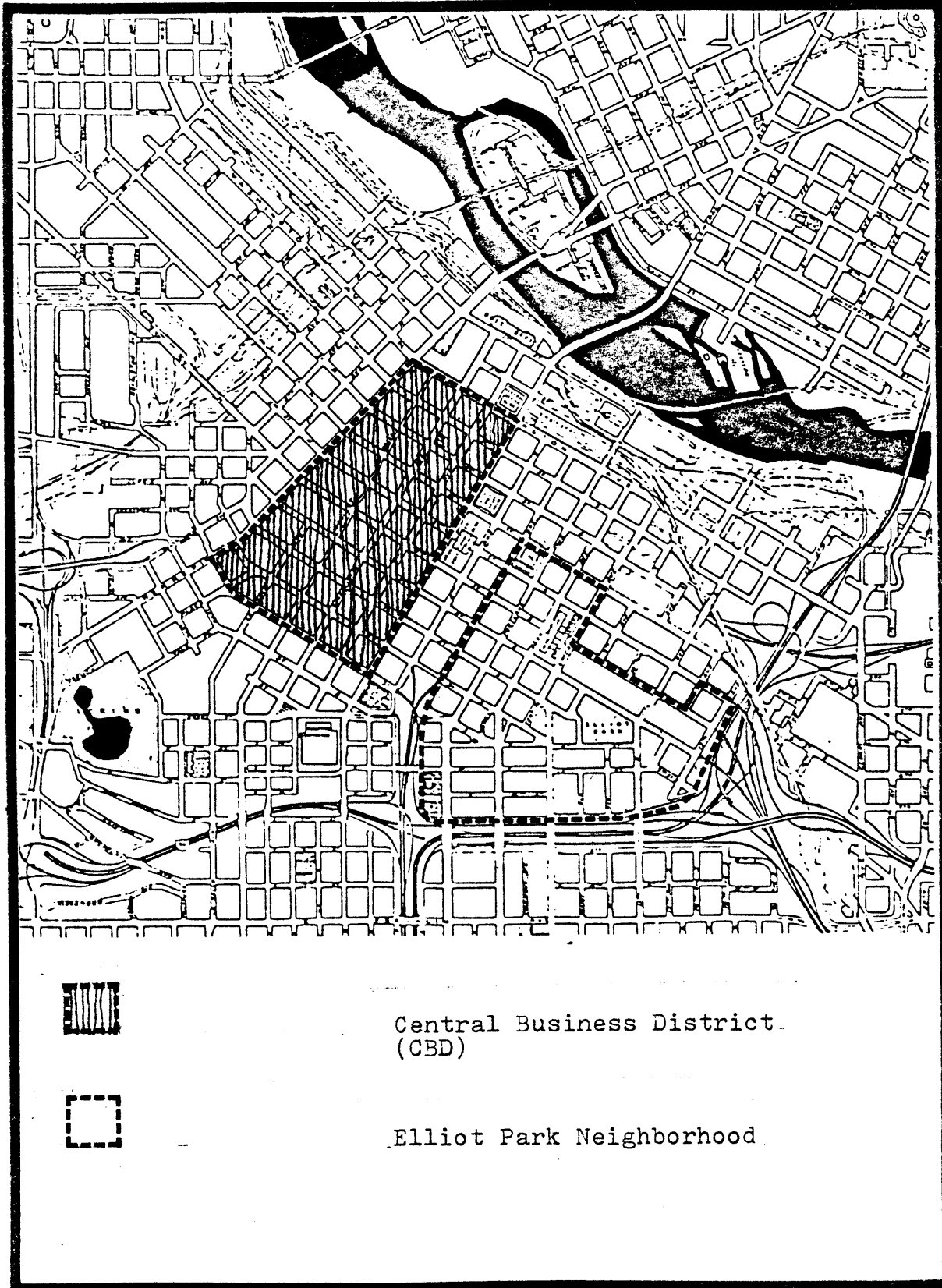

Figure 5-14

Elliot Park is the city's oldest neighborhood. Founded by Swedish immigrants who located at the southern edge of the present industrial park.. in the 1850's, its history has been largely that of a working class community. Evidences of the settler community still remain in the area's three churches and the Swedish hospital that was built on the north side of the park. It was around this park that two other hospitals were also built. One St. Barnabas, combined with the Swedish Hospital to form the Metropolitan Medical Center. The other is the former Asbury Hospital, located on the south side of the park, which is now the home of the North Central Bible College. Recently the Metropolitan Medical Center (600 beds) joined the Hennepin County Hospital (500 beds) in a shared services program. The combined medical facility is the largest in the state.

The heyday of the neighborhood was at the turn of the century when its best homes, located just south of the park, were owned by members of the city's middle class. The greatest growth in the community was in the years after World War I when the city of Minneapolis rapidly expanded. Here to the western edge of the community, speculative apartments were built to accommodate the influx of city workers. A decade later the Depression saw the greatest density in the neighborhood, as people flocked to the area to take advantage of its inexpensive rents and proximity to city jobs.

With the post World War II suburban expansion, the movement of the poor to other parts of the city, and the death of original residents, the area began to lose population. With this decline came the demolition of the housing stock as the institutions expanded

around the park and the commercial and industrial development encroached from the west. The freeway, built in the early 60's, effectively isolated the community from the neighborhoods to the south. Gradual street widening to provide fast, one-way commuter arterials destroyed the neighborhood's pedestrian sidewalk quality.

Statistics from the 1970 census tell the story of the neighborhood's decline:

	Elliot Park	Central Community	Minneapolis
Ages 65 or older	28%	24%	15%
Ages 45-60	22%	25%	21%
Ages 16-24	22%	22%	16%
Average Annual Income (1970)	\$5,800	\$6,300	\$13,000
% Holding Laboring or Service Jobs	37%	26%	25%
% Decrease in Population (1960-1970)	53%	56%	17%
% Moved between 1965-1970	68%	72%	51%

As shown in the chart, Elliot Park is a home for the elderly and for young adults. Because of lower education and employment levels, the average income is among the lowest of any area in the city. The population has declined three times faster than the rest of the city; there are only half as many people in the area as there were 25 years ago. Transiency in the neighborhood is high; 70% of the residents have lived in the community for five years or less, and 49% have lived there for two years or less.

The neighborhood has the largest unemployment rate in the city, as well as the highest welfare and public assistance enrollment.

With this high degree of instability, the community suffers from a high crime rate. Juvenile delinquency is three times the city average, while street crimes are twice the city average. Instability is also reflected in the housing patterns, where 90% of the housing stock is renter occupied.

The population, crime, and housing statistics reflect in the neighborhood's land use patterns, which show the diversity of extreme mixed use. Since 1923 the land has been zoned very intensively at B1-3, which permits a variety of less intense uses and a standing FAR of 3.4, with zoning premiums that raise the FAR to 12 (see Figure 5-15). The results of this zoning are reflected in the neighborhood's land-use map which depicts an intermingling of manufacturing, commercial, institutional, and a variety of residential densities. Consequently, the intensity of land use and the subsequent building patterns are varied and chaotic.

Because of the city's commuter traffic over the years, the streets have been gradually widened. This has led to a large number of major arterials piercing the neighborhood. Fourth and Fifth Avenues provide freeway access to the south; Fifth and Sixth Streets provide freeway access to the east; Seventh and Eighth Streets provide state highway access to the south; and Portland Avenue and Chicago Avenue provide major arterial access to southern neighborhoods. The division of the community by vehicular traffic is extensive; in addition to the daily rhythm of commuter traffic, there is the unpredictable 24-hour emergency ambulance interruption to either the public Hennepin County Hospital or the the private Metropolitan Medical Center (See Figure 5-11).

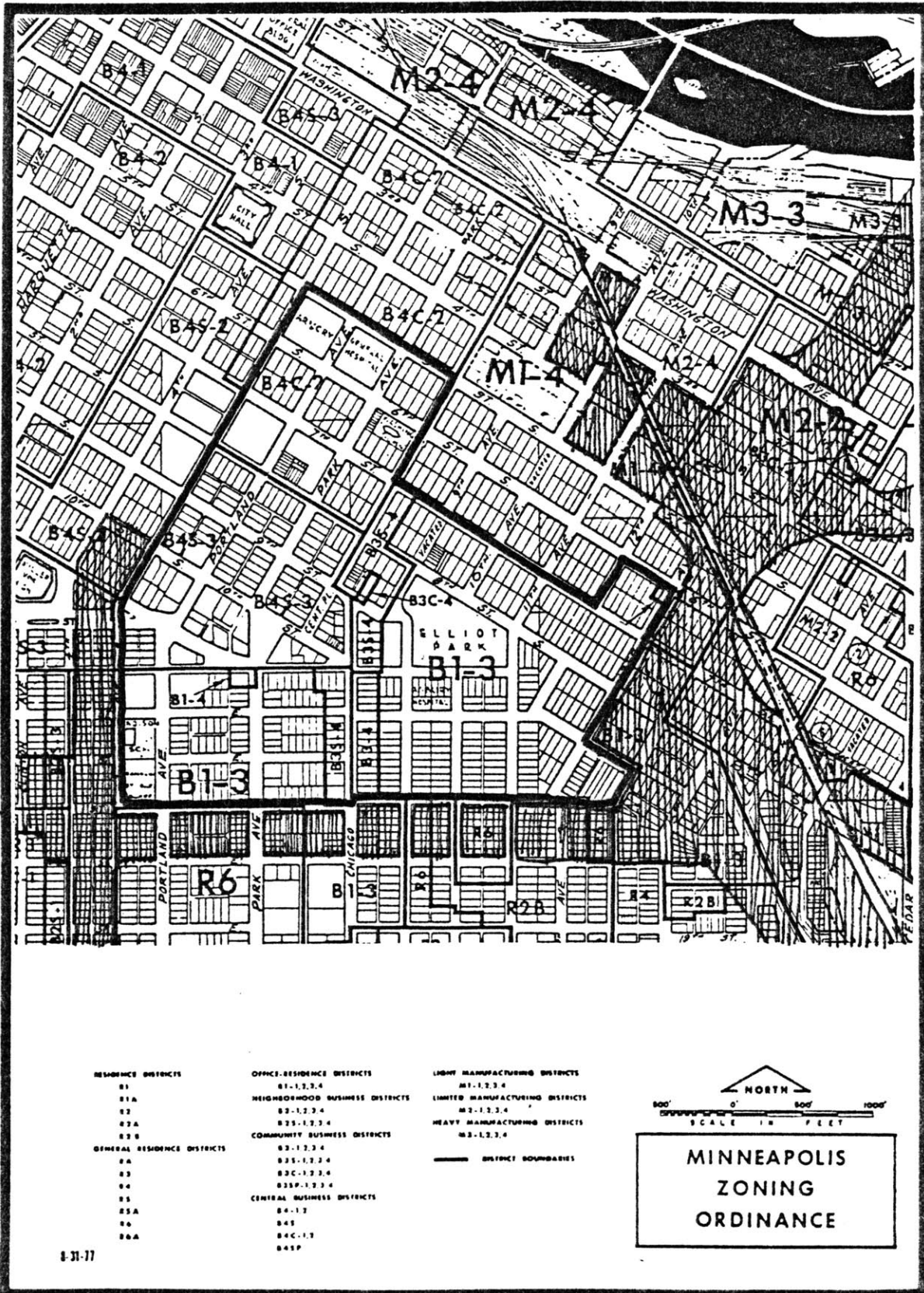

Figure 5-15

Other open space is devoted to the major green spaces in Elliot Park, the 6.9 acre park in the center of the city neighborhood, which is really a major city asset, and Franklin Steel Park, a 1.9 acre park in the southwestern corner of the neighborhood that is presently used as a playground. Both parks are vastly underutilized. The park, surrounded by institutions, is isolated from Park Board recreational use; Franklin Steel Park is inaccessible due to the freeway to the west and Portland Avenue, a major arterial, to the east. The neighborhood is divided into the following percentages of built and open space:

Built Space	Open Space
27.5% residential	1.6% vacant land
16.5% institutional	45.5% vehicular transportation and parking lots
7.5% commercial	
1.5% industrial	
<hr/>	<hr/>
53.0% Total	47.0% Total

Throughout the sixties and early seventies, Elliot Park languished. During that time, however, several urban pioneers moved into the neighborhood, having sensed the potential in its varied housing stock, its proximity to downtown, and its proximity to hospital jobs. Their early community organizing effort started the "Chicago Elliot Park Organization," which functioned as a voluntary, grass-roots consciousness raising group.

The establishment of the Community Development Block Grant Program in 1974 brought opportunities for planning assistance to the community. In 1975, the neighborhood group was encouraged by the Central Planning District Citizen's Advisory Committee to draw up a proposal to fund

preliminary planning efforts for the community. The award of the planning grant by the City Council was the beginning of the planning for the neighborhood's upgrading. The impetus for the application came when HRA designated it as a neighborhood emphasis area. Subsequently the City Council granted the CDBG funding to the HRA and the Planning Department for a neighborhood planning program in Elliot Park. In September, 1976, the Elliot Park Neighborhood, INC, (EPNI), a non-profit corporation, was formed to speak for the neighborhood. Its working core was a group of six activist urban pioneers. With the research and technical support from the Planning Department staff, EPNI, through a series of monthly town meetings and bi-weekly task force meetings, prepared the Elliot Park Improvement Plan. The planning effort took from September, 1976 to May, 1977. After a year of public lobbying by EPNI, the plan was formally accepted by the city in May, 1978.

The goals and objectives of the plan are briefly reviewed here to give the reader a sense of the community's concerns and priorities. Program implementation strategies will be mentioned as necessary to cover the development of the design guidelines.

I. Land Use

Housing Goals:

- + to promote and encourage the rehabilitation of existing housing.
- + to rehabilitate housing without significant displacement.
- + to develop the identity of an urban residential neighborhood.

Objectives:

- form EPNI housing committee.
- form EPNI Neighborhood Development Corporation.

- start rehabilitation program in single family and multi-family structures.
- start rent subsidy program.
- encourage building code enforcement.
- develop rehabilitation resource book.
- establish a rental clearing house for landlord/tenant rental information.

Transportation Goals:

- + to lessen the impact of through traffic in the community.
- + to limit downtown parking in the community.
- + To encourage pedestrian and bicycle use in the community.
- + to provide off-street parking for the neighborhood and community's businesses.
- + to increase transit ridership in the community.

Objectives:

- reexamine bus routes and service patterns.
- study potential for 9th Street greenway.
- study street redesign.
- petition public works department and MTC for bus shelters.
- lobby for bike-way designations.
- designate critical parking zones.

Environmental Quality Goals:

- + to identify buildings worthy of historical preservation.
- + to improve the acoustical environment.
- + to improve public street lighting.

Objectives:

- start clean-up programs.
- inventory neighborhood's historic buildings.
- lobby for freeway barriers and traffic reduction measures on neighborhood streets.

Regulatory Goals:

- + reevaluate existing land use regulations.
- + study present zoning patterns for down-zoning.
- + study traffic patterns for rerouting and street closures.

Commerical Goals:

- + to stabilize the business climate for neighborhood commercial activity.
- + to stop the encroachment of the downtown-related businesses into the neighborhood.

Objectives:

- develop mini-parks
- develop community gardens

II. Community Services

Public Safety Goals:

- + to enhance the public well-being by improving public safety.
- + to create community interdependence and interaction through human services programming.

Objectives:

- develop neighborhood surveillance program.
- develop safe house program.
- develop whistle stop program.
- request police foot patrols.
- start Operation ID.

Health Service Goals:

- + to increase public awareness of neighborhood health programs.
- + to improve delivery of health care programs.

Objectives:

- utilize chemical dependency programs.
- increase health services out-reach program.
- develop health maintenance home visitation for senior citizens.

Educational Service Goals:

- + to improve the basic educational and survival skill of neighborhood population.

Objectives:

- initiate community education on alcoholism.
- initiate community education on crime prevention.
- initiate continuing education program via public schools.

Employment Service Goals:

- + to improve access to employment opportunities.

Objectives:

- initiate employment out-reach program.

Community Facilities Goals:

+ to develop community facilities.

Objectives:

- locate temporary community center.
- plan new community center.
- develop programs via recreation committee.
- develop day-care program.
- develop neighborhood information center.

Shortly after the improvement plan was published, the community successfully sought contributions from seven downtown corporations for a housing policy study that would inventory existing conditions and prepare a strategy for improvement. The housing policy study was completed in May, 1978. Determinations of the community's housing requirements were based on dividing the neighborhood into four areas, with three phases of implementation (see Figure 5-16). Phase 1A would stabilize the single family housing with rehab activity in Area C; Phase 1B would develop in-fill housing and rehabilitate the older multi-family housing in Area A along 9th Avenue. Phase 2 would rehabilitate and build infill housing in the eastern portion of the neighborhood, where the future land use was in doubt with the uncertainty of the sports stadium completion. Phase 3 would concentrate on rehabilitation and the interior greenway in the southwestern quadrant of the community.

A further recommendation for the housing policy report came from a random sample questionnaire about desirable future inhabitants. The results suggested that the community should try to attract young families and children to fill a void in the present population spectrum. In addition, it suggested that the community do all it could to prevent

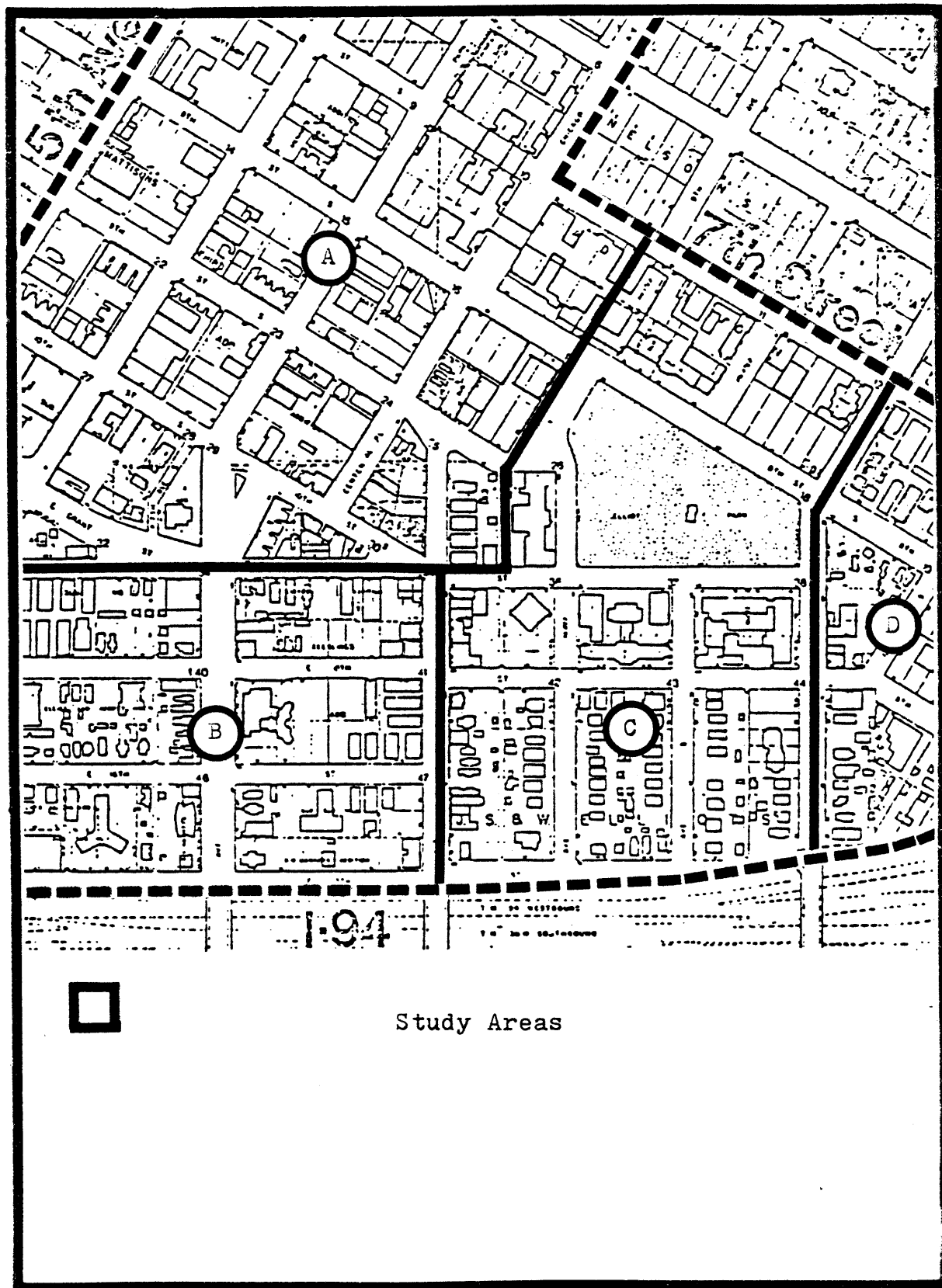

Figure 5-16.

displacement when land values, and hence rents, begin to climb with rehabilitation efforts.

Response to the housing policy proposal started immediately. With a \$311,500 a year in CDBG housing rehabilitation grant, the Neighborhood Improvement Corporation received a matching grant of \$300,000 from private corporate interests to purchase and rehabilitate existing apartments. Rehabilitation is beginning on this project now, presently known as "Old-Town-in-Town." When it is finished, the community will have 60 units of cooperative housing, all of which will receive Section B rent subsidy.

In January, 1978, the HRA started to prepare a redevelopment plan for the neighborhood. The plan was based largely upon minimal land acquisition and relocation. The HRA would apply for 7.5 million dollars in UDAG funding for the neighborhood in order to finance land acquisition improvements and relocation of the existing rental occupants. Once the land was acquired and improvements made, the properties would be sold to private developers who would rehabilitate the units, receive a Section 8 allocation for some units, and rent the remaining units at market rate. To date a NSA commitment of 400 Section 8 units has been awarded by HUD. The UDAG funding proposal is pending.

The neighborhood improvement plan set other forces at work as well. One of the key issues in the land use goals was the rezoning of the neighborhood. The proposed rezoning scheme approved in the plan (see Figure 5-17) was consistent with the proposed central community land use plan (see Figure 5-18). In October, 1978, the City Council approved the community sponsored proposal based on the neighborhood

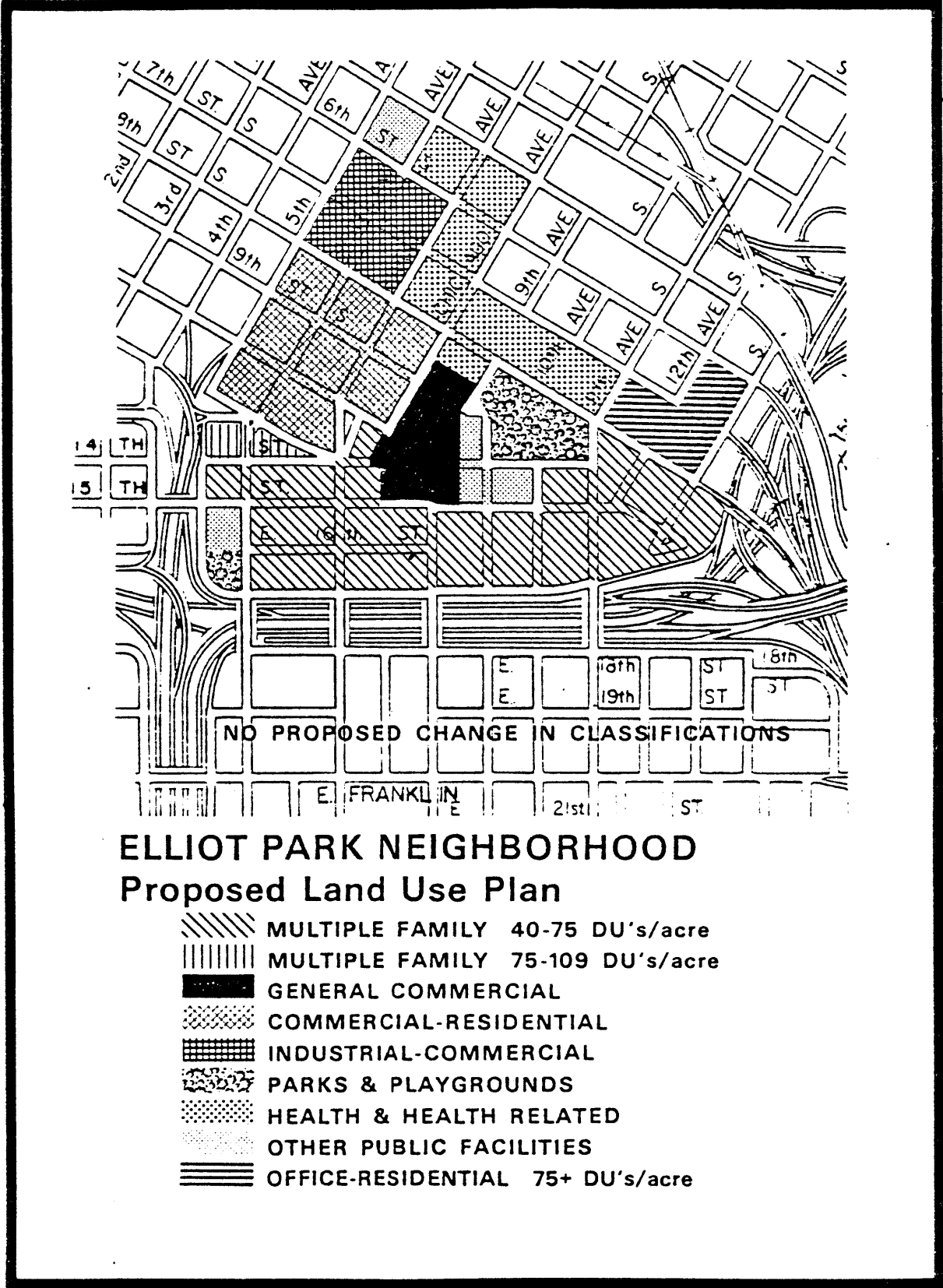

Figure 5-17

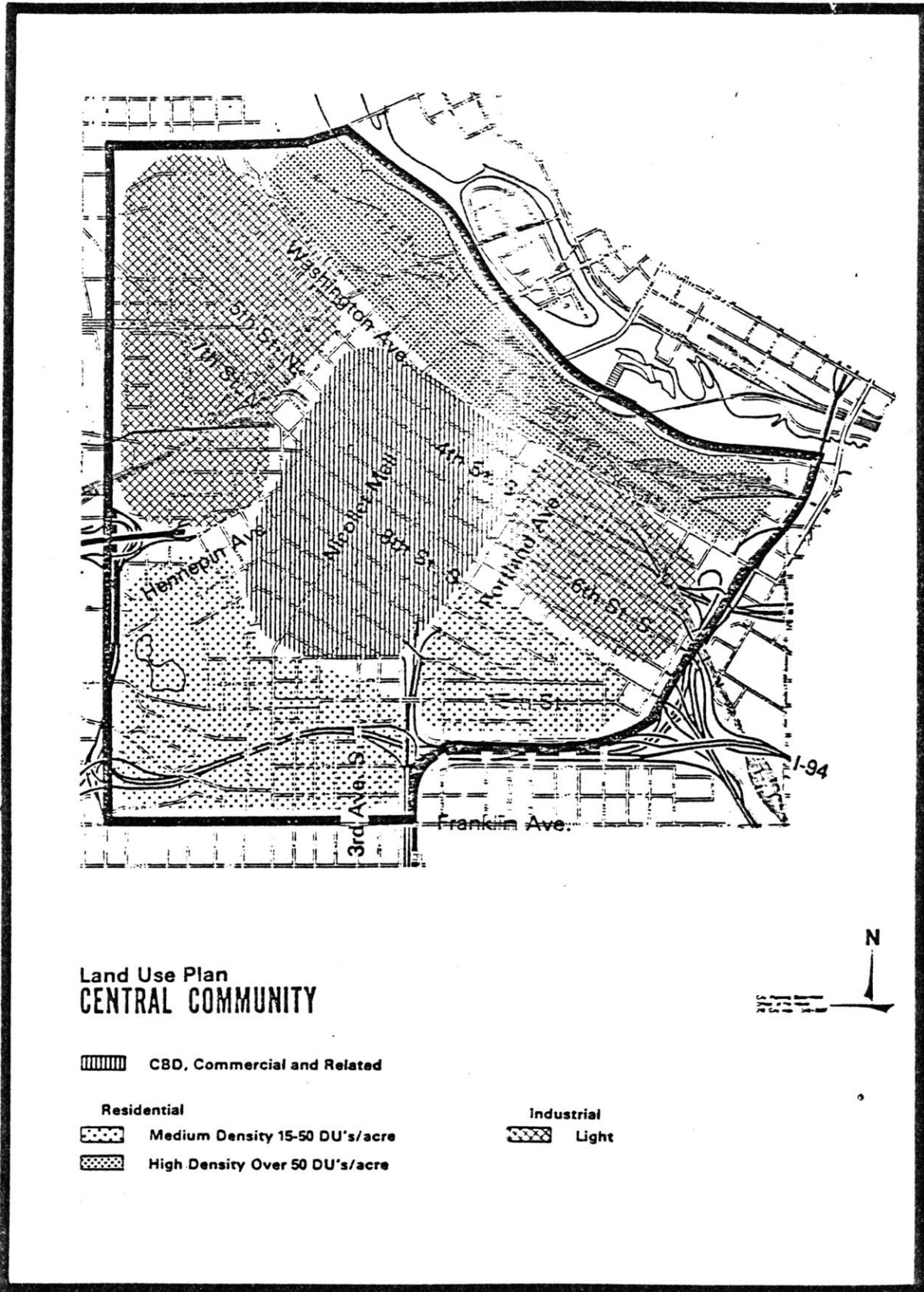
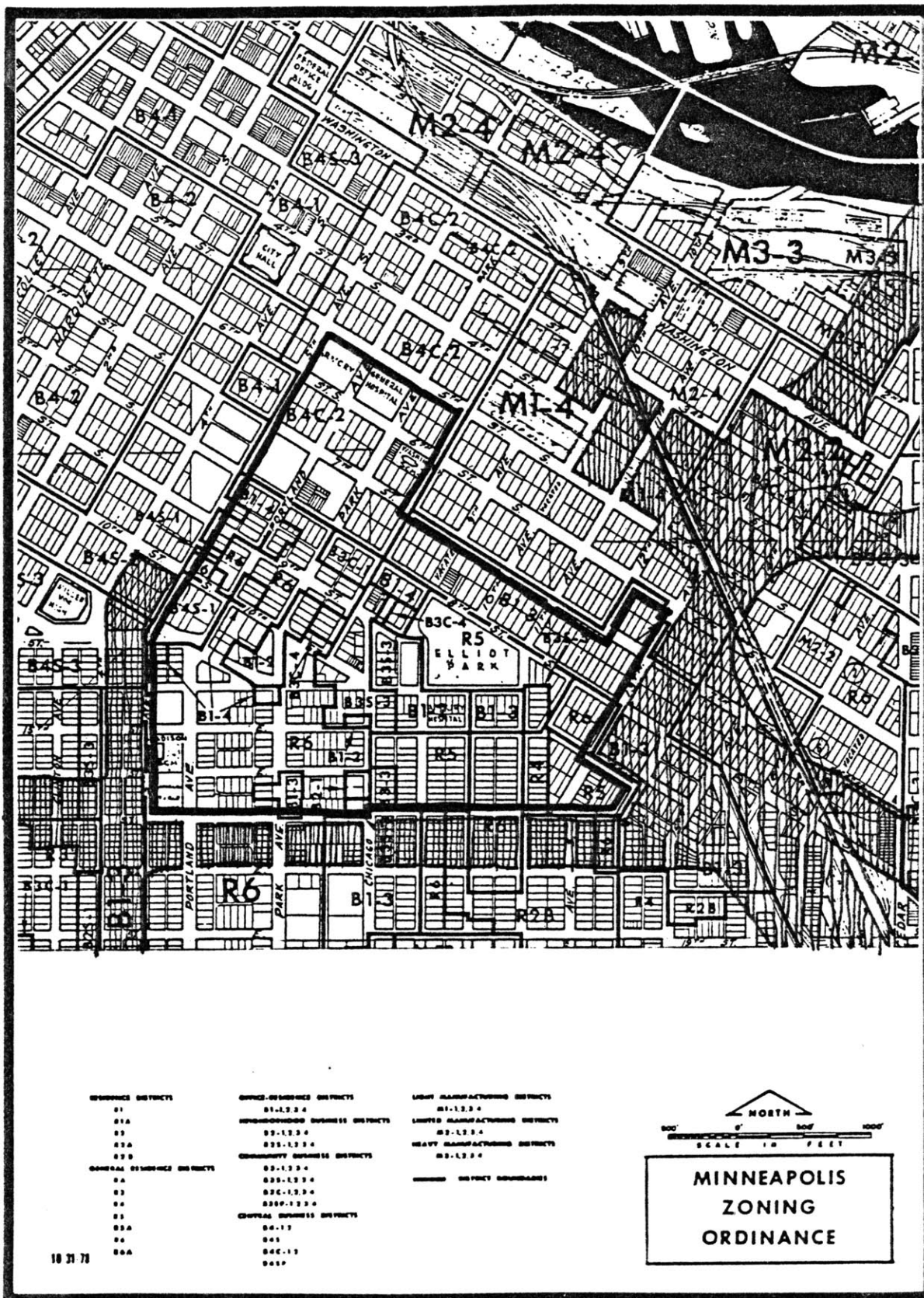

Figure 5-18.

plan, which changed much of the community from business zoning, B1-3, to residential zoning, R-5 and R-6 (see Figures 5-15 through 5-19).

After these planning efforts, private sector involvement is increasing in Elliot Park. In little more than two years, the neighborhood upgrading is beginning to take hold. One basic reason for this immediate commitment, apart from the quality leadership in the neighborhood, its obviously desirable location, and the energy crisis, is the proposed new sports facility, which is promoted by the downtown corporate interests.

The construction of the stadium would have a tremendous impact on the quality of life in the neighborhood. After examining several site and design alternatives over the course of a year's study, the Metropolitan Stadium Commission recently selected the Minneapolis site for the proposed stadium. The development of the Minneapolis stadium could happen only with the purchase of the stadium site from its owners at a cost of 23 million dollars by the downtown business community and its free donation to the city. The gift of land for the stadium to the city is contingent upon the corporate donors receiving the development rights to the riverfront development area adjacent to Elliot Park for the next 15 years. This agreement was recently made by the City Council and approved by the mayor. The corporate interests that are purchasing the land and receiving development rights over 35 acres of riverfront land are the same corporations that have funded the studies and planning activities in Elliot Park. Having witnessed the successful community resistance to the new-town-in-town several years before and hearing of initial



resistance by the Elliot Park community to a stadium neighbor, the corporate stadium backers looked after the community; hence they were faced with little resistance to the proposal.

Presently the stadium is being guaranteed by the public sector 2% liquor tax within the metropolitan area that will provide the support for the revenue bonds that are being issued to cover its construction and initial operation. Without non-property tax support for the revenue bonds, the stadium would not be built.

Despite the future of the stadium, Elliot Park is becoming an attractive neighborhood for private sector redevelopment. It is gradually experiencing reinvestment via institutional growth and expansion, as well as the infusion of new institutions. Figure 5-20 shows the location of many of these new facilities (listed below); their number suggests the large amount of reinvestment that is taking place in the neighborhood:

1. The new branch of Northwestern National Bank--1975.
2. The new Augustana Nursing Home extension--1976.
3. The new Hennepin County Hospital in partial merger with the renovated Metropolitan Medical Center, a private hospital--1972 to 1976. Total beds: 1100.
4. The proposed multi-sports stadium--1981
5. The proposed branch of Midwestern Savings and Loan.
6. The proposed new student center and gymnasium at Northwestern Bible College.
7. The proposed private corporate sector housing development.
8. The proposed phase-two construction of Augustana Nursing Home--100 beds.

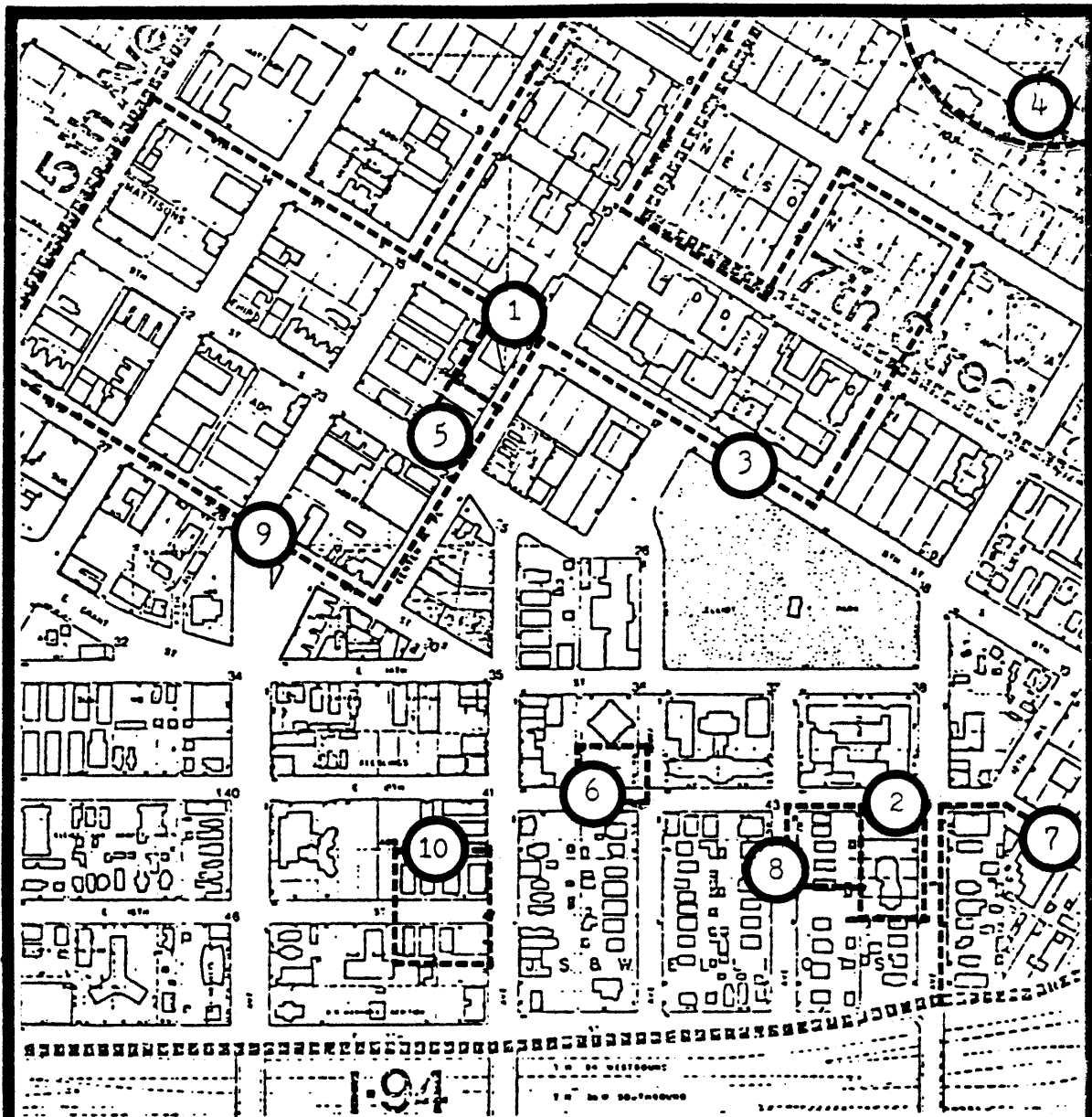

New and Proposed Development in Elliot Park

1. Northwestern National Bank (Branch)
2. Augustana Nursing Home - Phase 1
3. HGMC/MMC Hospital Complex
4. Minneapolis Multi-Sports Stadium
5. Midwest Savings and Loan Association (Branch)
6. NCBC Student Center and Gymnasium
7. Private Sector Housing
8. Augustana Nursing Home - Phase 2
9. Ninth Street Infill Housing
10. Old Town In Town (Section 8 Housing)

Figure 5-20

9. The proposed infill housing along Ninth Street.
10. The proposed UDAG rehabilitation area in combination with 400 NSA Section 8 housing units.

Other locations will be developed if the new multi-sports stadium construction proceeds on schedule (completion--1981). Many building sites will include store-front commercial uses to attract the pedestrian traffic.

A review of the building stock in Elliot Park shows that many of the structures are well built and capable of recycling rather than being demolished to make room for new development. A number of these buildings are candidates for designation as historical sites by the Historic Preservation Commission, a designation which would ensure their preservation.

In addition, the neighborhood morphology reveals the lack of thematic space seen in the limited white area in Figure 5-21. Figure 5-22 reveals examples of the development models previously discussed. The physical diversity created by the collision of these models is clearly seen in the figure-ground study (see Figure 5-23).

Given the desire of the Elliot Park neighborhood community group to control development, recycle existing buildings, and preserve the scale of the low-rise residential areas, there is a need to regulate new physical development.

This brings us to the need to develop design guidelines that can be developed and sponsored by the neighborhood. As the design review authority for the neighborhood, similar to the urban renewal area's project area committees, the EPNI needs criteria which will help it monitor new development to make it more sympathetic with the

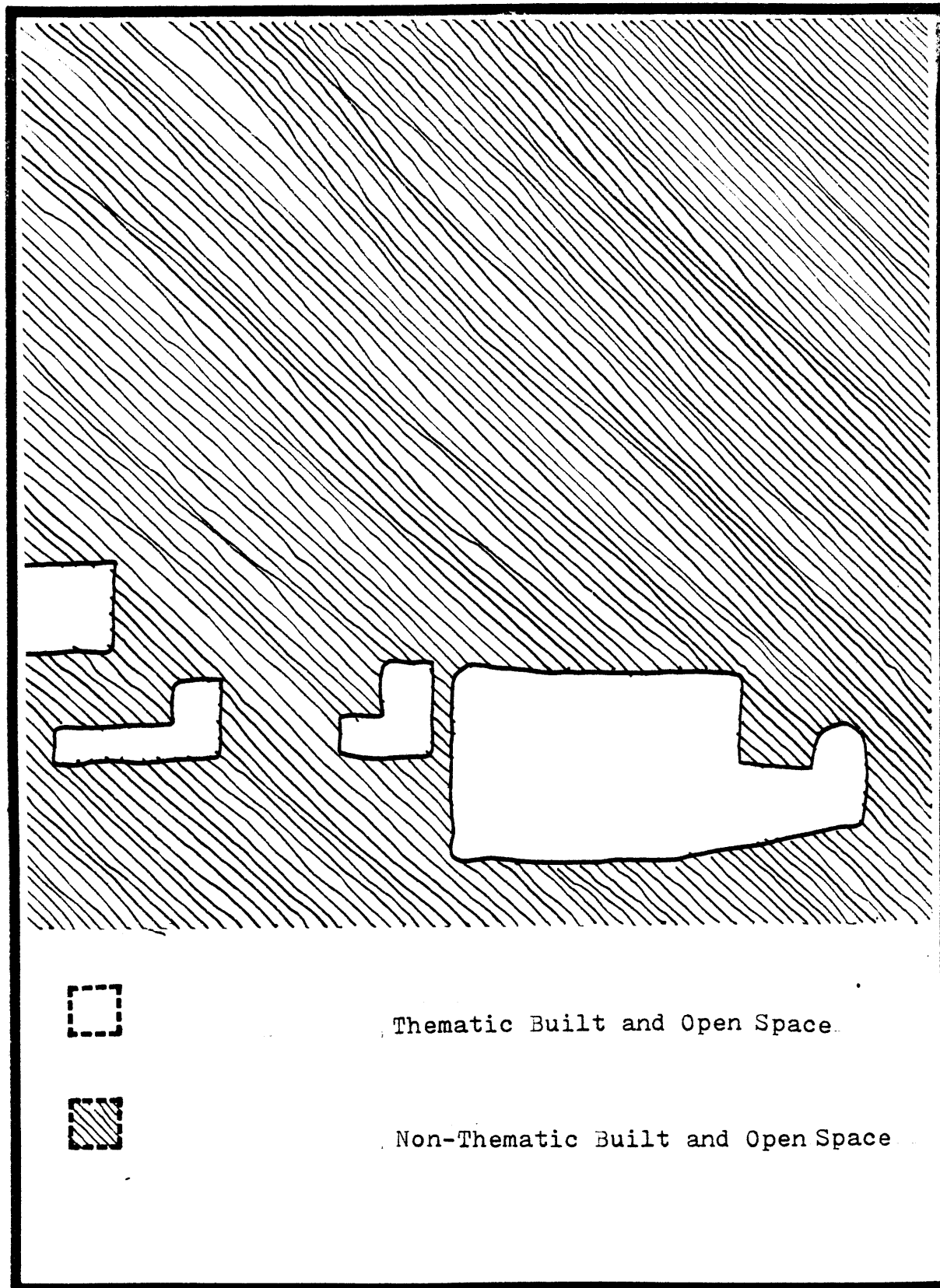

Figure 5-21

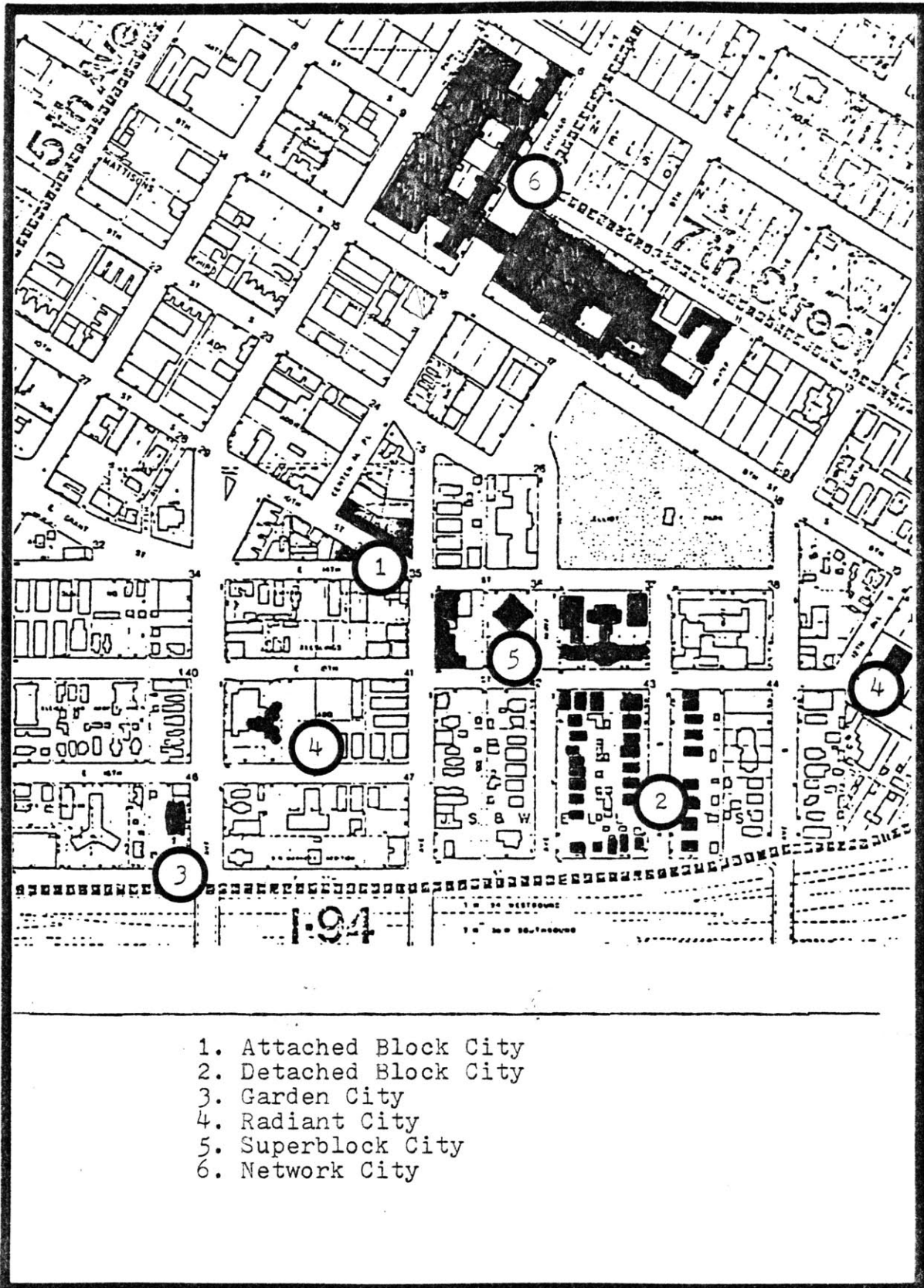

Figure 5-22

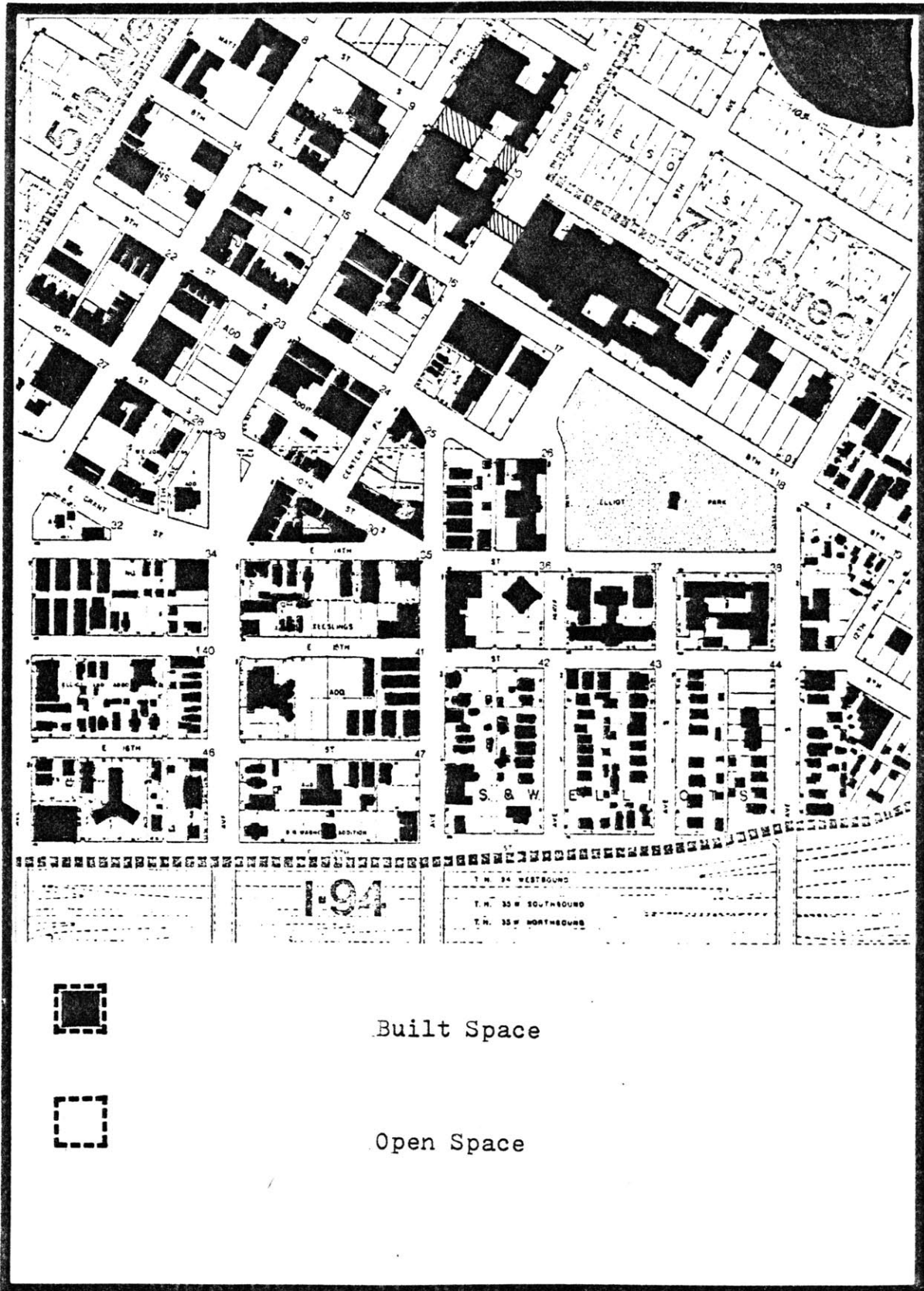

Figure 5-23

neighborhood context, prescriptive criteria which conventional zoning laws fail to provide.

To summarize, we have selected Elliot Park for a variety of reasons. First, the neighborhood contained a great diversity of building types and functional uses. Hence it was a fertile ground for testing a design method organized to create physical cohesion. Second, the neighborhood is within an inner-city area that is experiencing pressures for institutional and commercial expansion. Hence the use of design guidelines would help moderate the design of building programs that are insensitive to neighborhood patterns. Third, Elliot Park has an active neighborhood organization that is determined to create a neighborhood of environmental quality. Hence there is an opportunity to apply the guidelines in actual practice through neighborhood sponsorship.

The next chapters will discuss several development scenarios in Elliot Park and suggest how our guidelines can help to ameliorate the impact of new development, to replicate desired existing development, and to initiate desired new development.

Chapter 6

Augustana Nursing Home Expansion (Amelioration)

Step One

Augustana Nursing Home is an institutional facility located on the south side of Elliot Park. It has been a member of the community for thirty years as an extended care facility for the local Augustana Lutheran Church. As a nursing home it offers continued medical and religious care from the institutions in the area. Presently it is experiencing a tremendous growth rate due to the rising number of elderly people in the urban areas of the city, many of whom are the older members of the church's congregation.

In 1977 a new mid-rise "Radiant City" addition was added to the northwest corner of the study block, shown in a non-thematic designation. This project was developed with the B1-3 zoning category of the time which allows mid-rise construction as a less intensive land use. Consequently the thirteen story apartment building and its corner parking ramp have devastated the residential character (built and open space patterns) of the residential areas surrounding the buildings.

Augustana Homes owns many of the houses on the present study block and is planning a 150 unit addition of approximately 150,000 square feet to the west side of the present mid-rise tower. The site is located on four lots on the northwestern corner of the block. The site was down-zoned from B1-3 to R-6 with the rezoning action that followed the acceptance of the Elliot Park improvement plan recommenda-

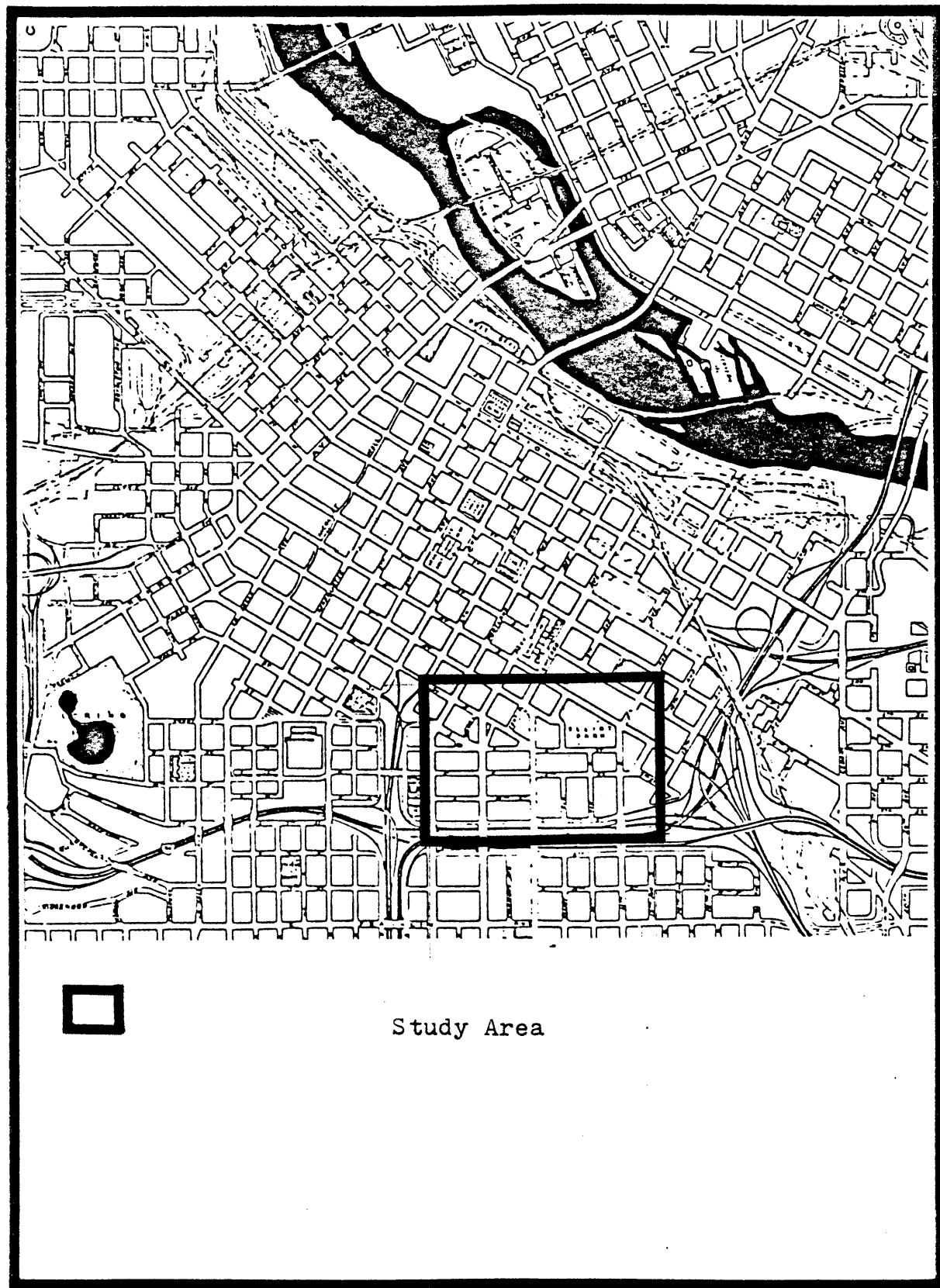

Figure 6-1.

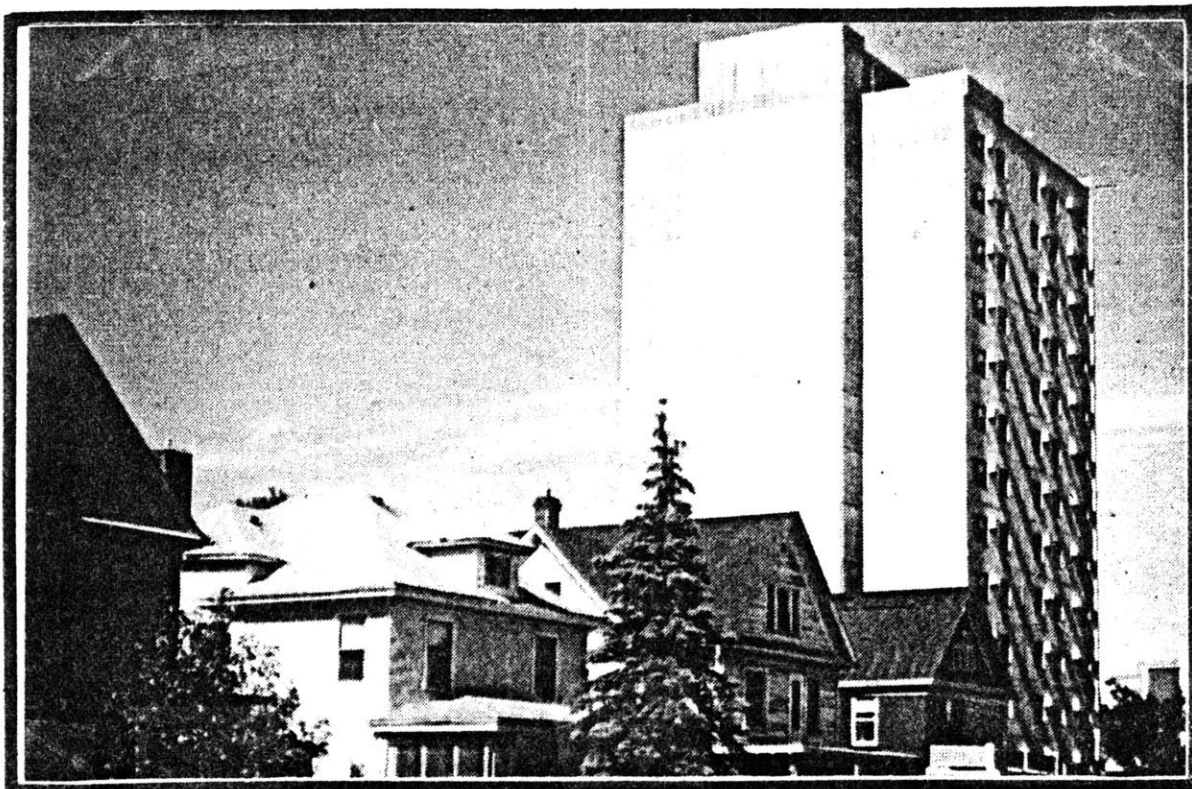

Figure 6-2

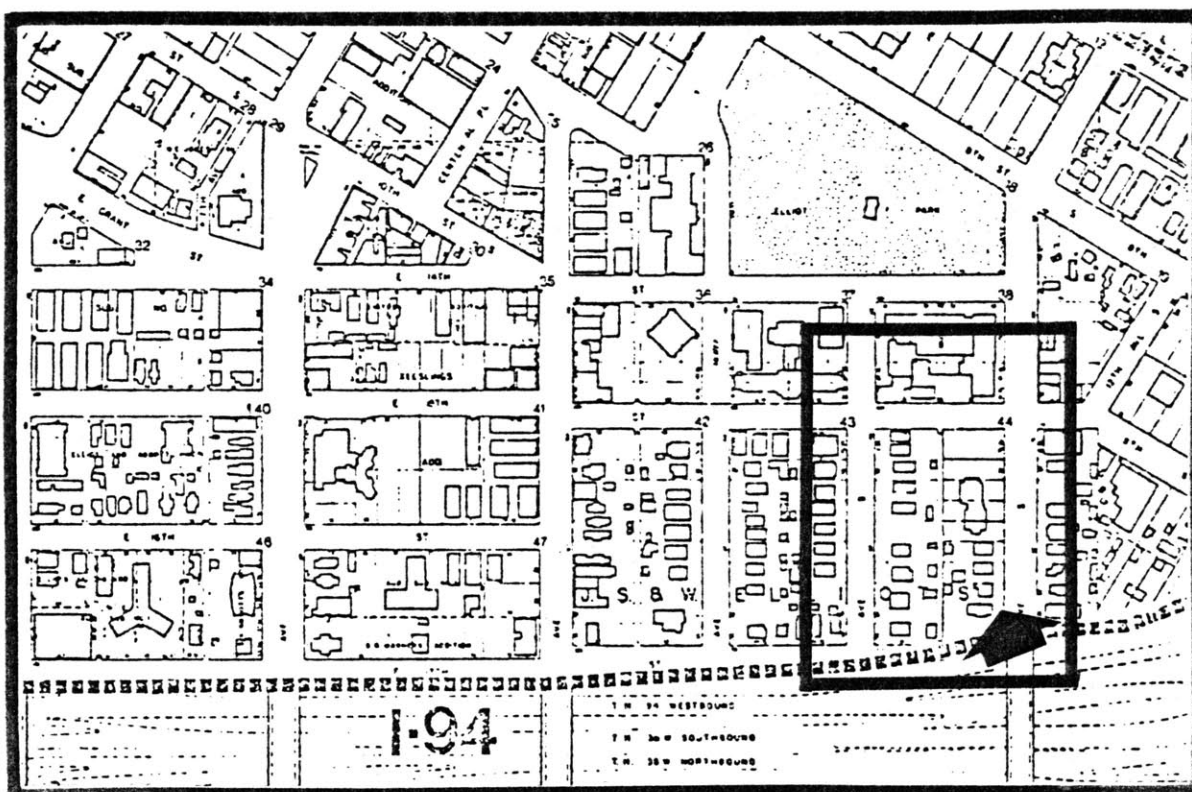

Figure 6-3

tions. The community distrusts Augustana's present development plans. It hopes that internally developed design criteria can articulate the position of the community in its negotiation with Augustana in planning the new facility. By developing this criteria, they hope that the project can proceed without destroying neighborhood scale and the economic viability of the project. In the process, the community will not be placed in a reactive posture of judging a predetermined Level 5 design without having pre-design influence at Levels 3 and 4.

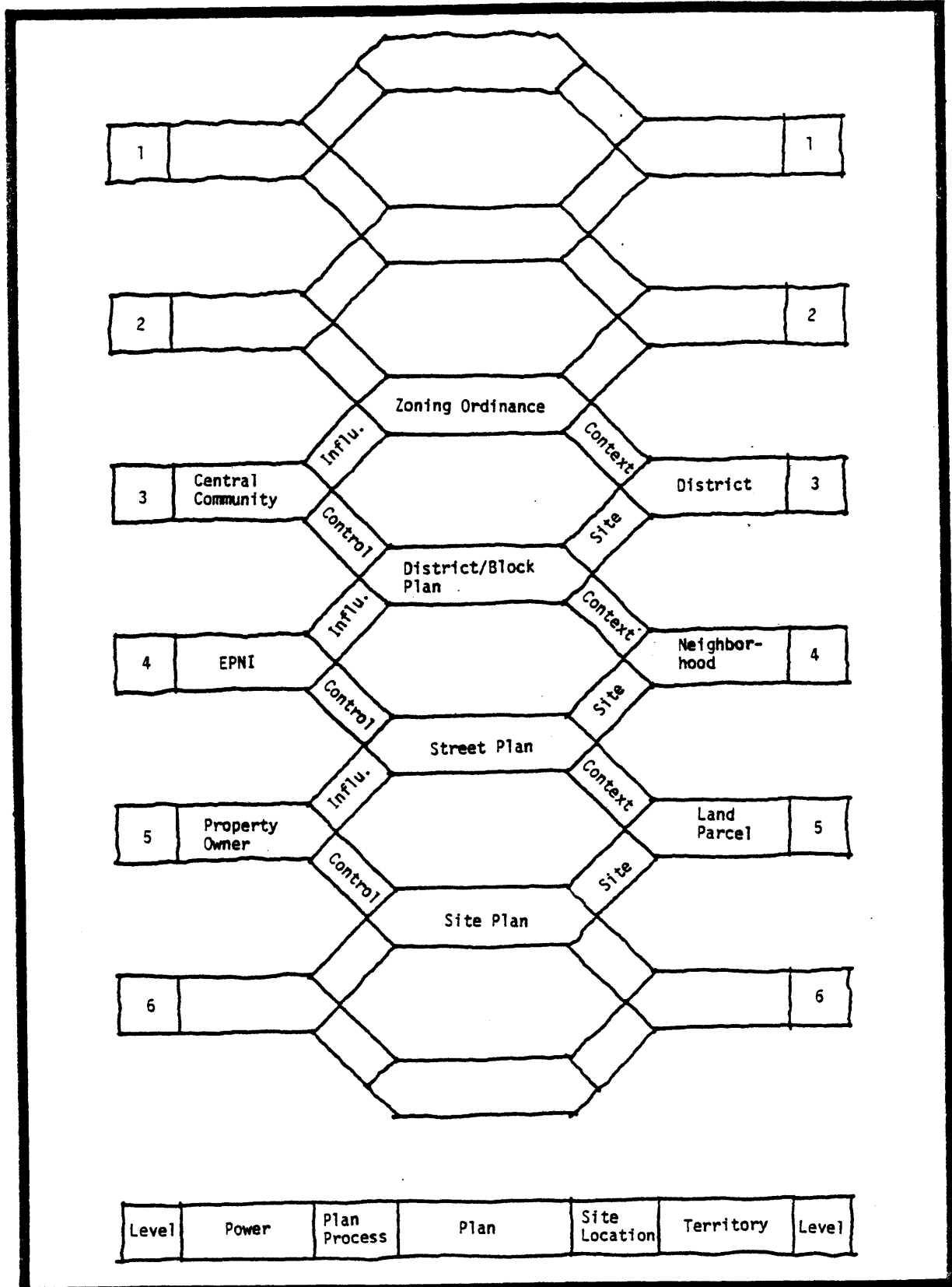

Figure 6-4

Step Two

Prepared by urban designers working with the Elliot Park Neighborhood Incorporated (EPNI). This step includes the following:

1. Identification of existing block. Figure 6-5
2. Identification of block parcels. Figure 6-6
3. Identification of block model (B). Figure 6-7
4. Identification of block model (O). Figure 6-8

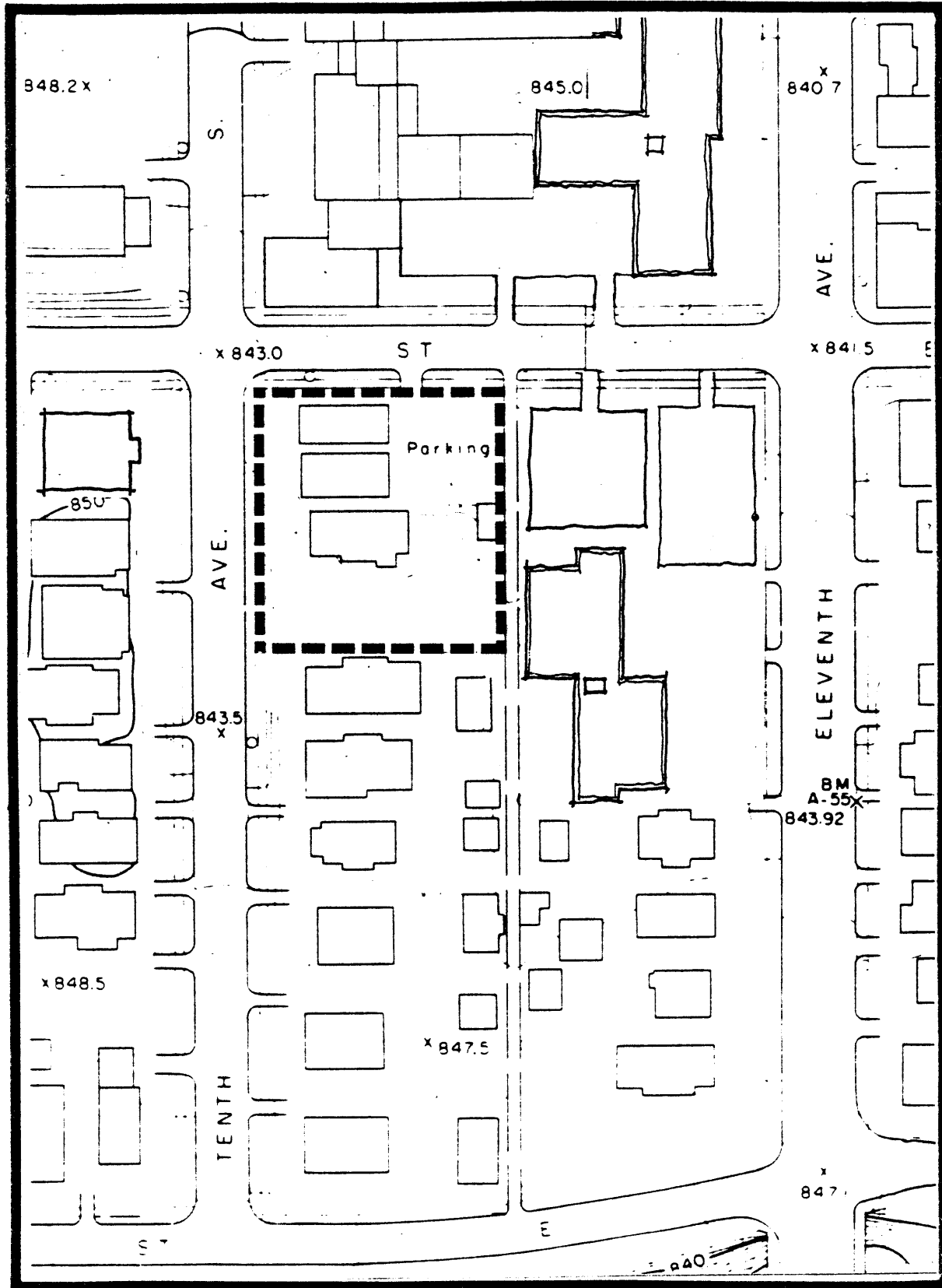

Figure 6-5

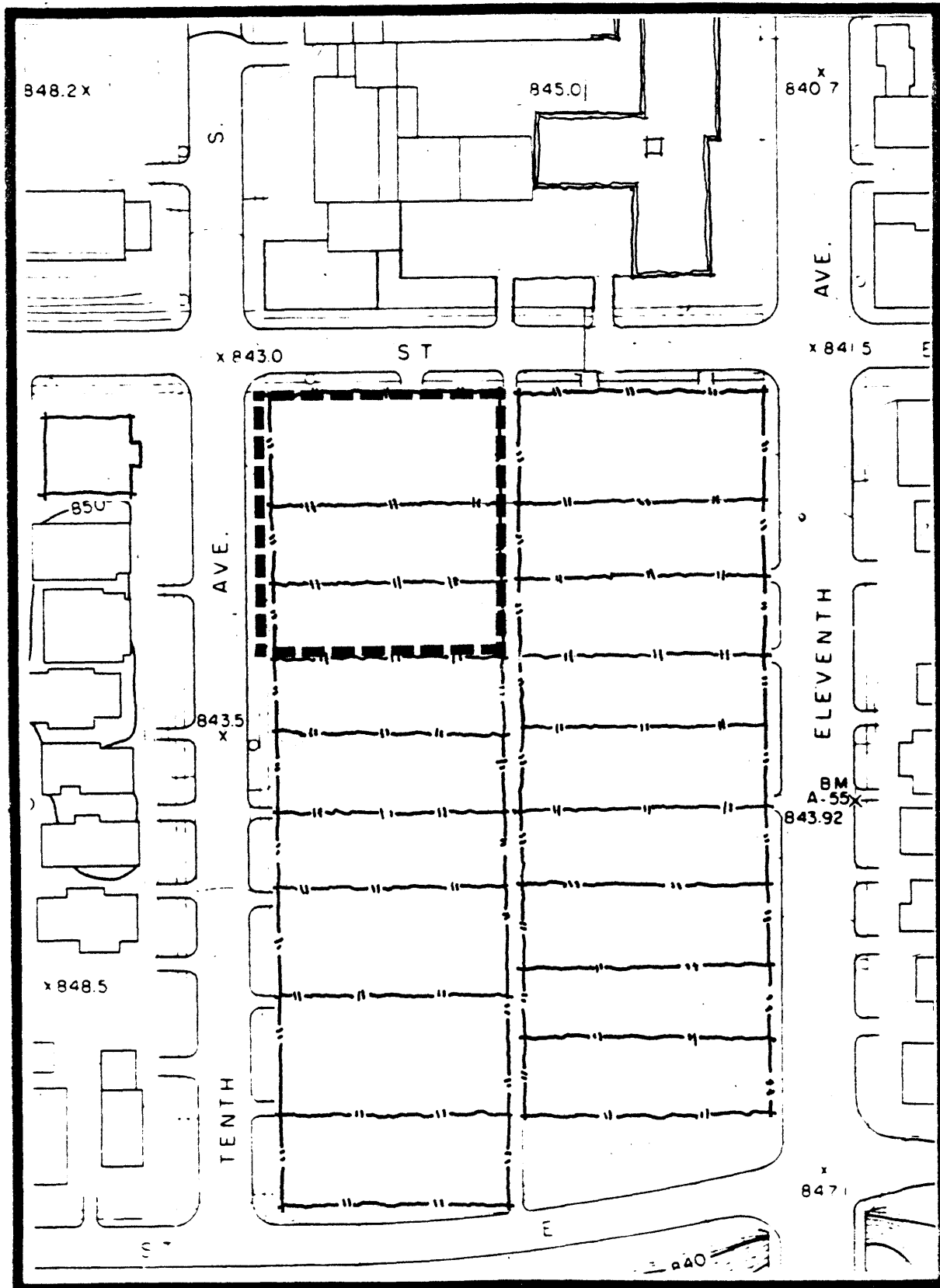

Figure 6-6

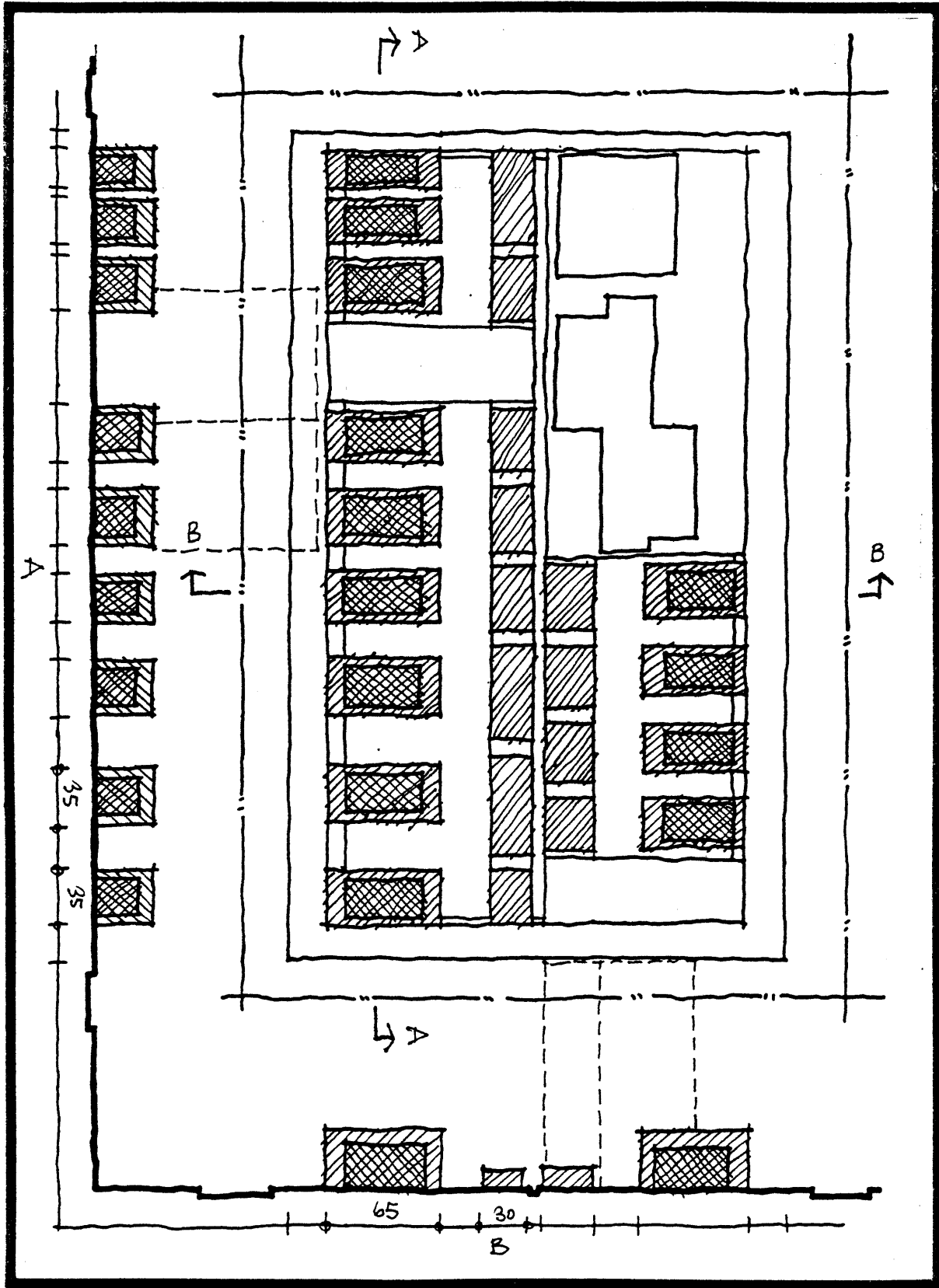

Figure 6-7

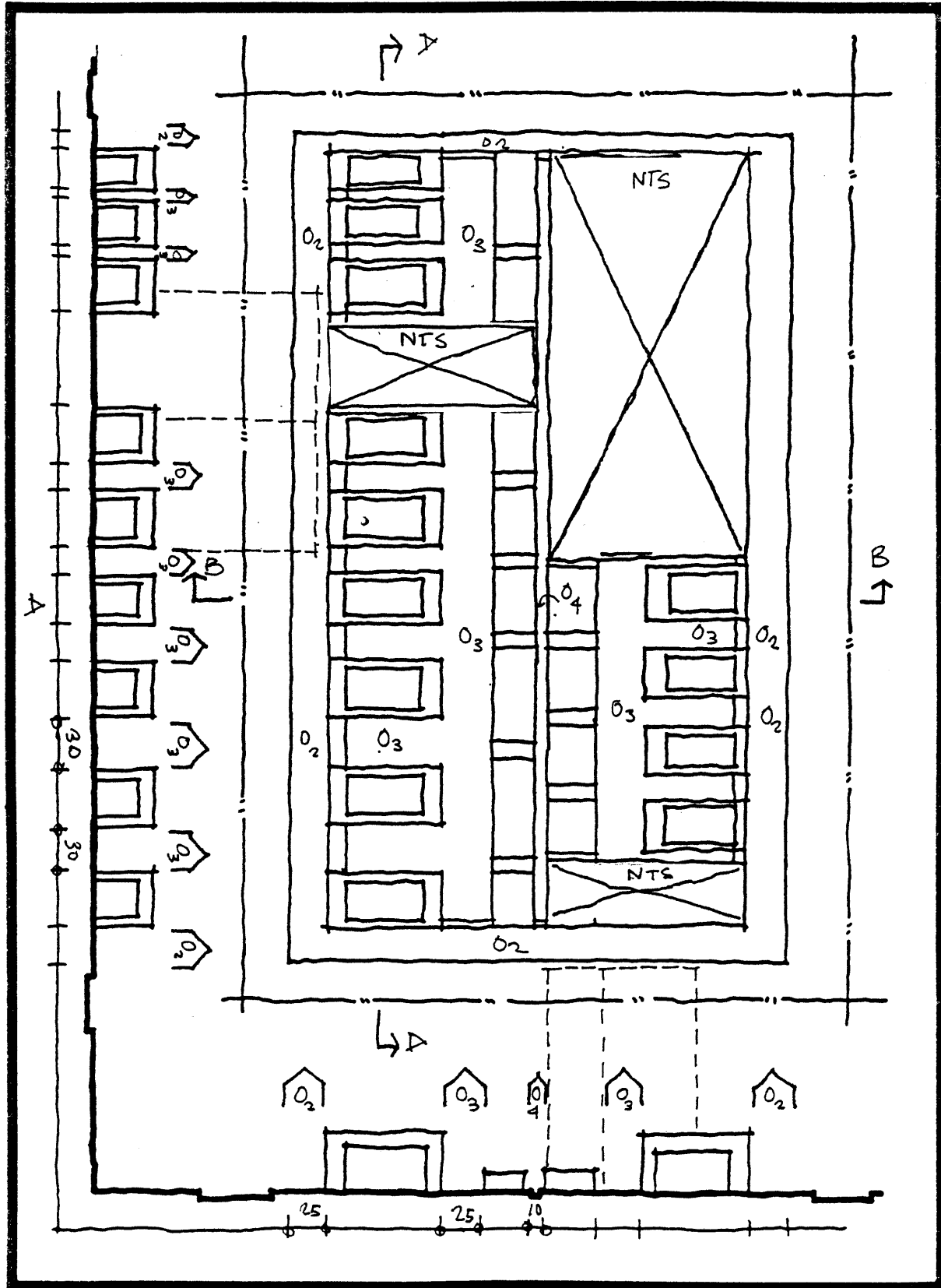

Figure 6-8

Step Three

Prepared by urban designers working with the Elliot Park Neighborhood Incorporated (EPNI) and block residents living in the environs of the site. It includes the development of the three pathway diagrams developed by the above groups through participatory processes:

1. Regulatory diagram Figure 6-9
2. Materials diagram Figure 6-10
3. Pattern diagram (existing) Figure 6-11

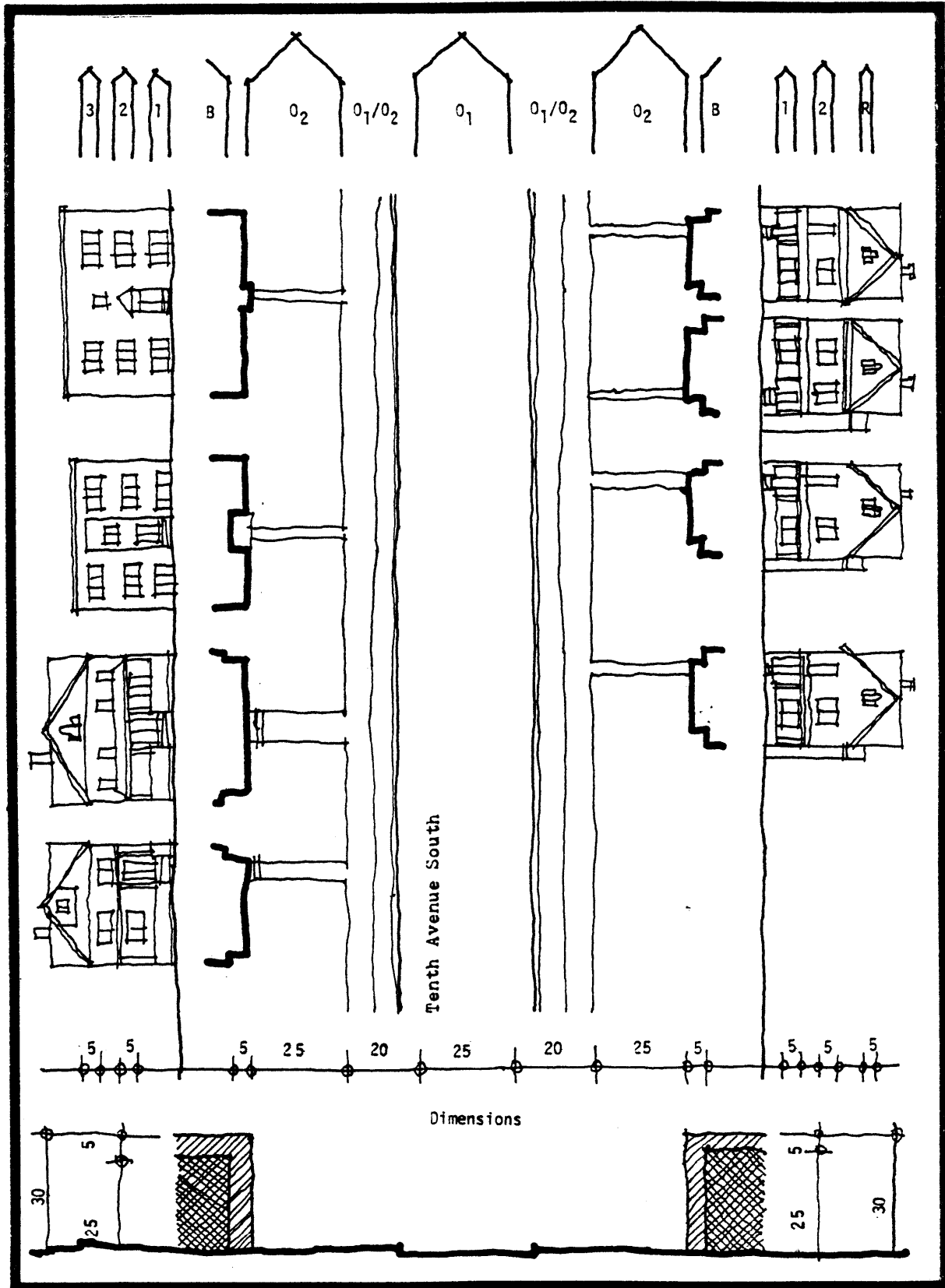

Figure 6-9

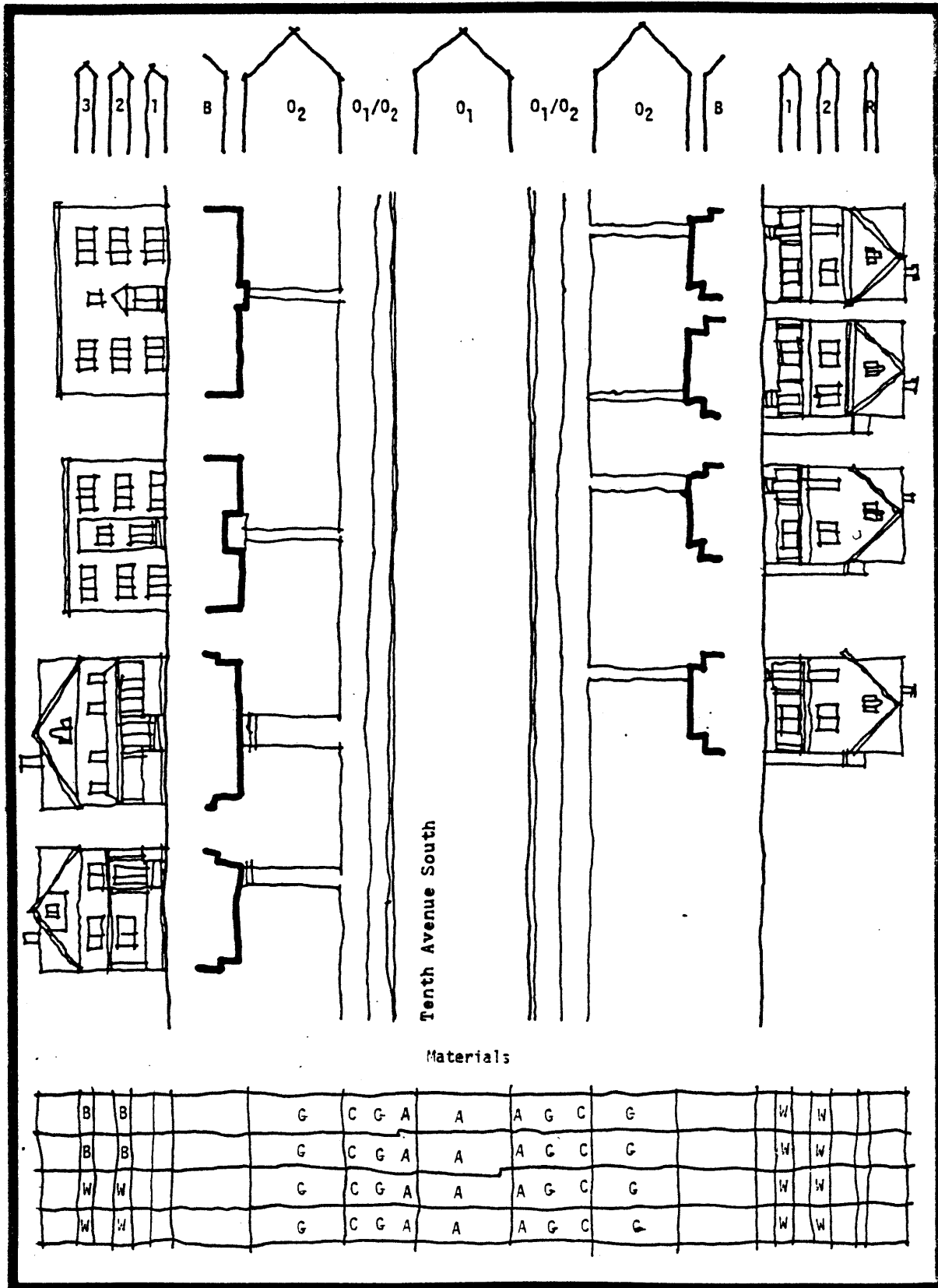

Figure 6-10

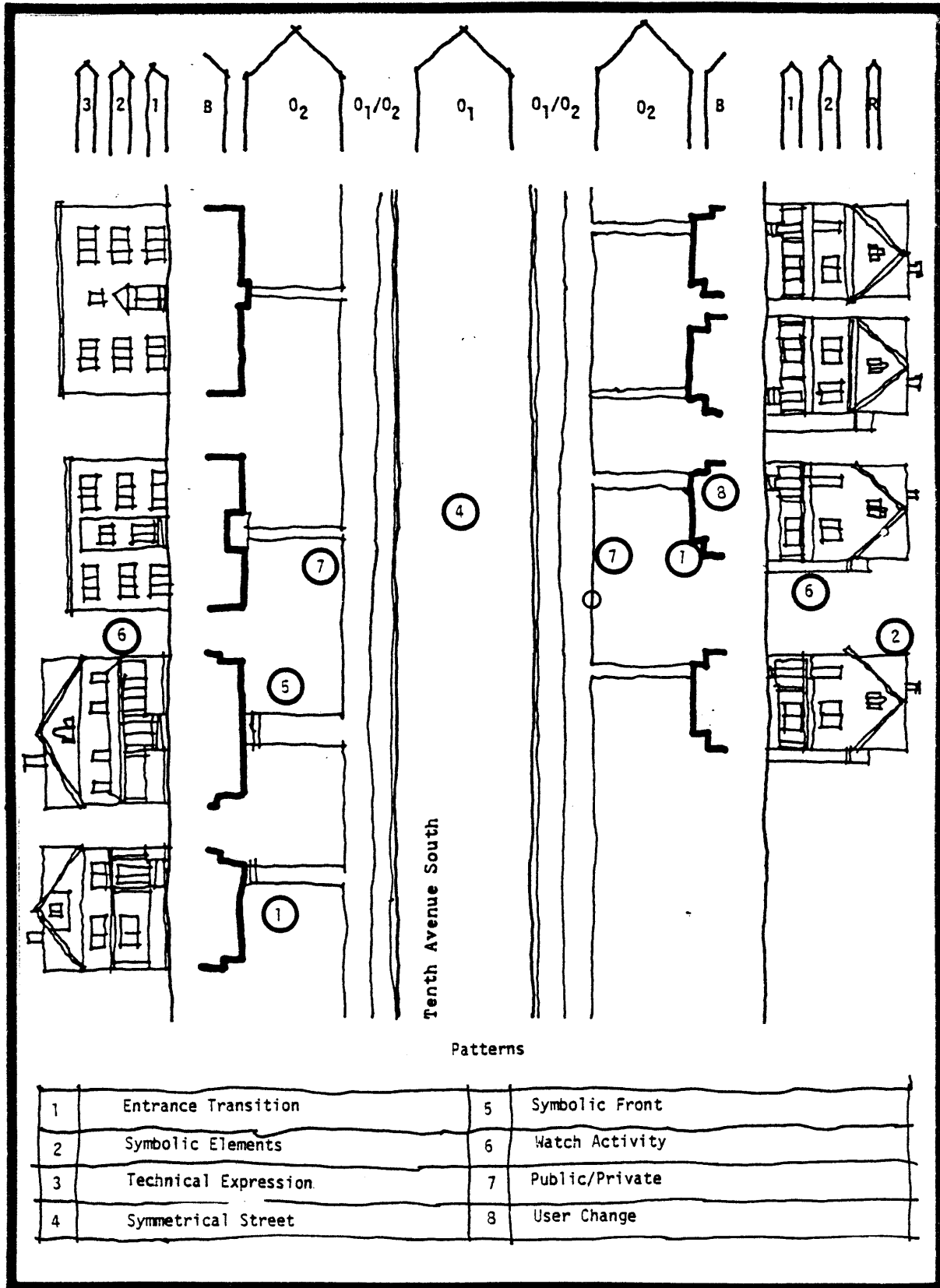

Figure 6-11

Step Four

The parcel/program analysis is prepared by the urban designers working with the Elliot Park Neighborhood Incorporated (EPNI).

The analysis includes the following steps:

1. Description of the building program. Figure 6-12
2. Description of the site area. Figure 6-12
3. Identification of zoning requirements. Figure 6-13, 6-14
 - a. lot size requirements
 - b. yard requirements
 - c. building bulk limitations (identification of FAR premiums if applicable)
 - d. off-street parking
 - e. off-street loading

Building Program: Long Term Care Facility

1. 100 one bedroom apartment units long term care. Each apartment unit 500 SF	50,000 SF
2. Circulation Space - 10% of area total	5,000 SF
3. Administrative and Social Space	<u>7,500 SF</u>
Total	62,500 SF

Site Area:

1. 150 FT x 225 FT	33,750 SF
--------------------	-----------

Expected FAR:

$$\frac{62,500 \text{ SF}}{33,750 \text{ SF}} = 1.85 \text{ FAR}$$

Fire Zone:

III

Figure 6-12

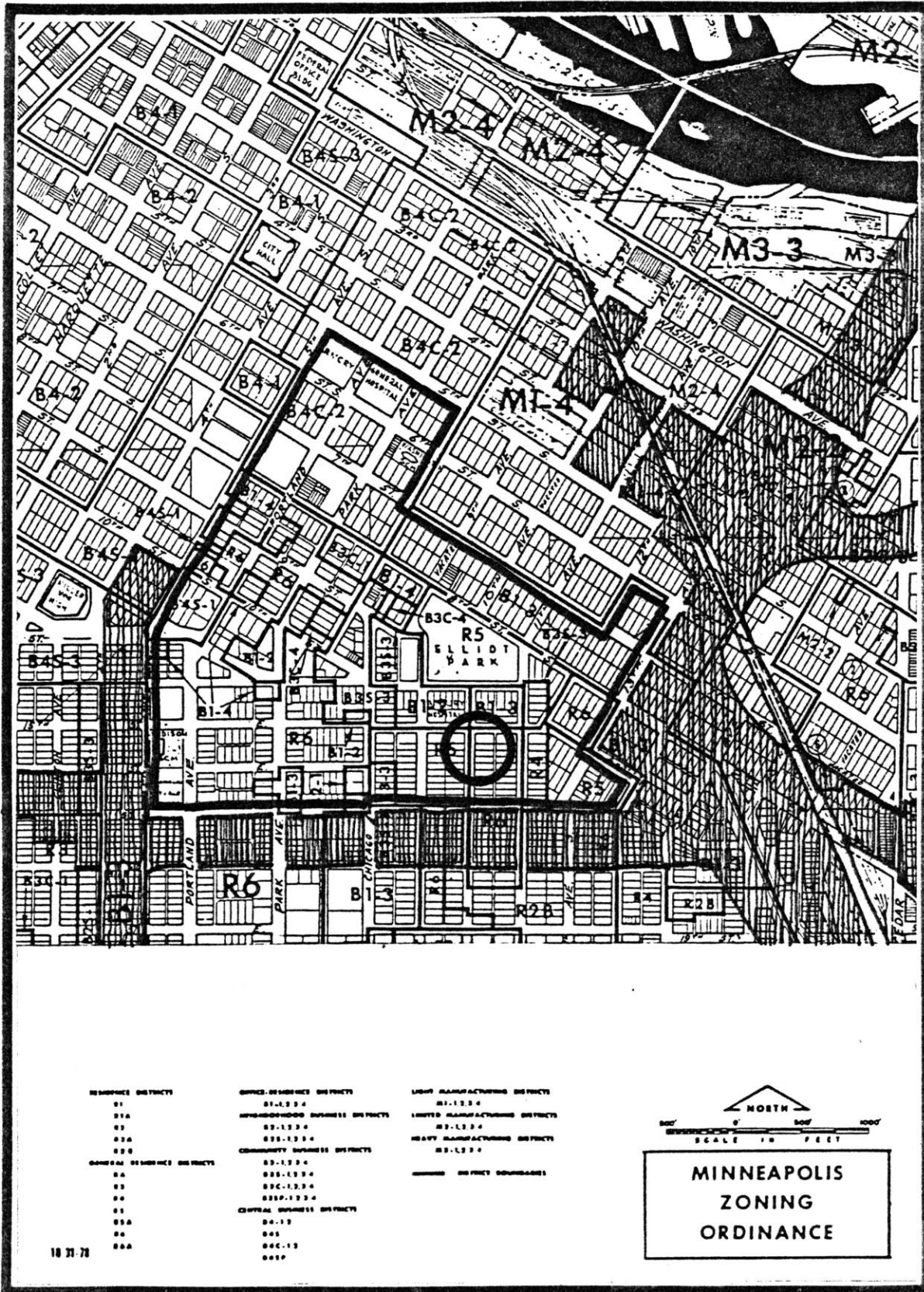

Figure 6-13

Zoning Requirements: R-6

Lot Size Requirements

- | | |
|---|-----------|
| 1. Minimum Lot Size | 100 FT |
| 2. Minimum Lot Area
300 SF per DU or 100 x 300 | 30,000 SF |

Yard Requirements: Assume Five Stories

- | | |
|--|----------|
| 1. Front: Not Less Than Adjacent Buildings | 20 FT |
| 2. Side: 5 FT + 2 FT x 4 FT | 13 FT |
| 3. Rear: 5 FT + 2 FT x 4 FT | 13 FT |
| 4. Corner: 8 FT + 2 FT x 4 FT | 18 FT |
| 5. Open Yard: 10% Lot Size | 3,375 SF |
| 25% Lot Size | 8,437 FT |

FAR for Nursing Homes as Conditional Use 2.1

Off Street Parking:

- | | |
|----------------------------------|----------|
| 1. One Car per 10 Beds | |
| 2. Assume One Car at 300 FT x 10 | 3,000 SF |

Figure 6-14

Step Five

This step is the review of the previous four steps and identifies the community's position for concept plan review with the City Planning Commission and the developer. These design guidelines are made up of the following information:

1. Parcel identification Figure 6-15
2. B analysis Figure 6-16
3. O analysis Figure 6-17
4. Pathway diagrams Figure 6-18,6-19, 6-20
5. Massing options consistent with the above Figure 6-21

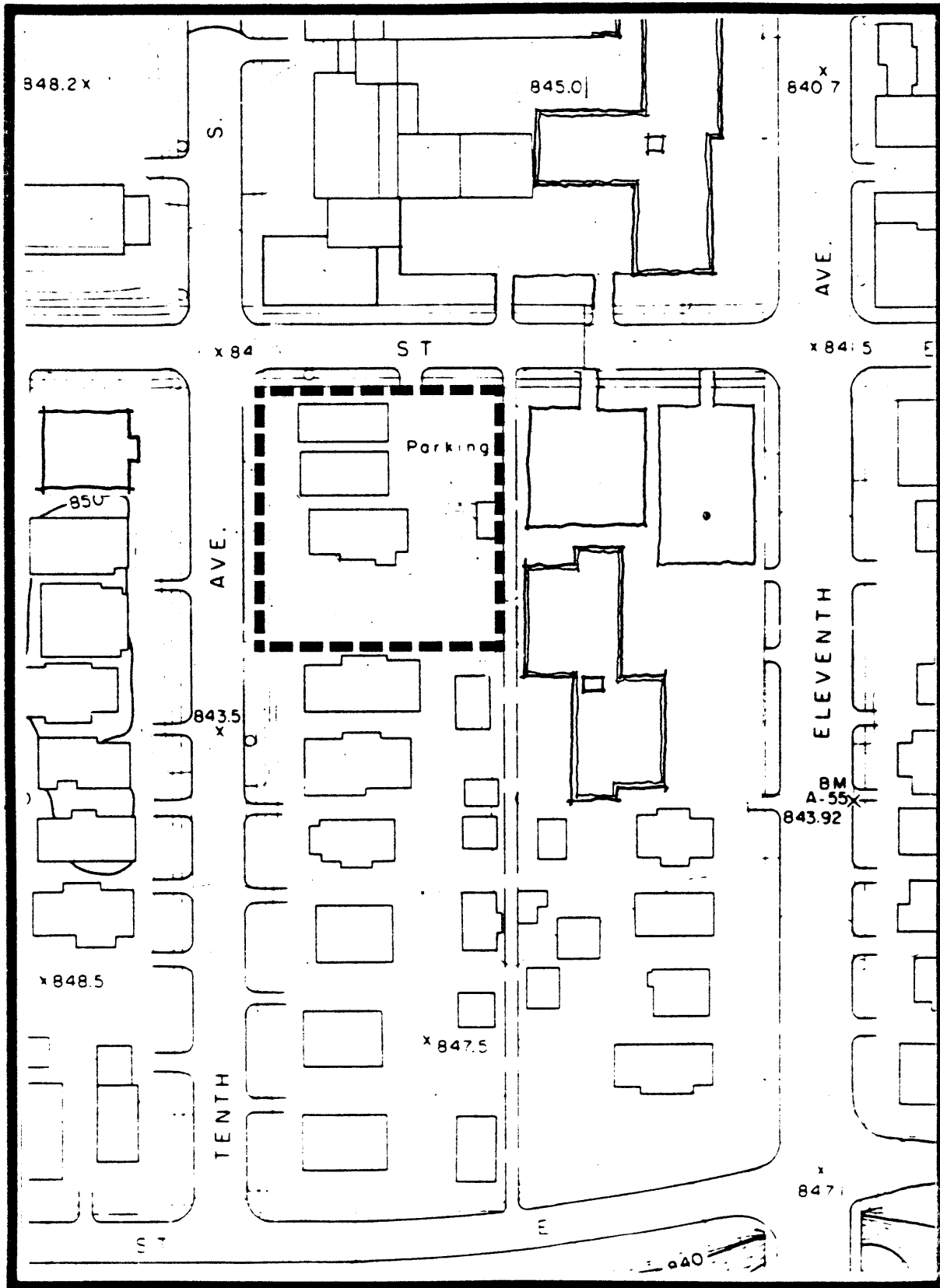

Figure 6-15

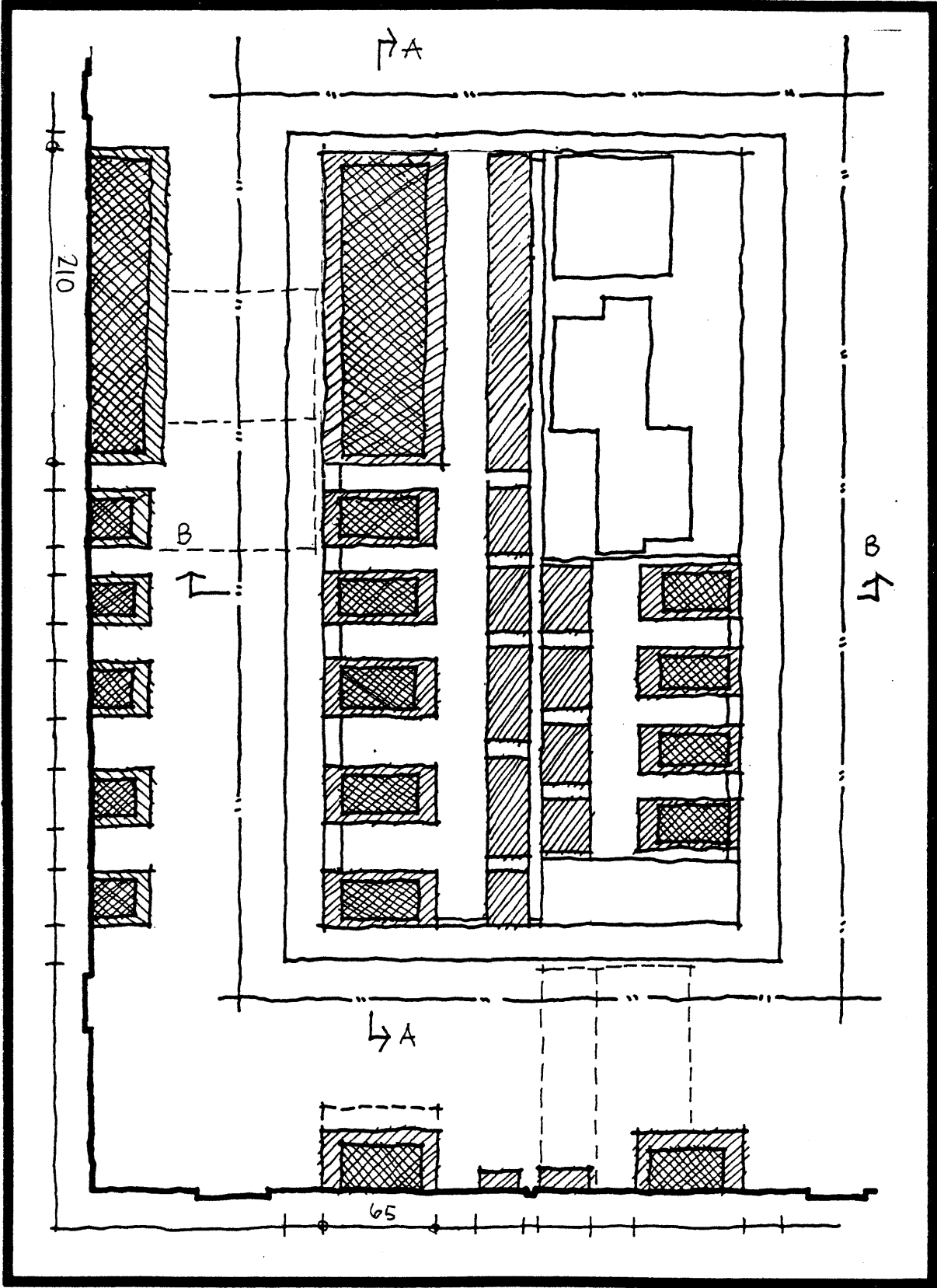

Figure 6-16

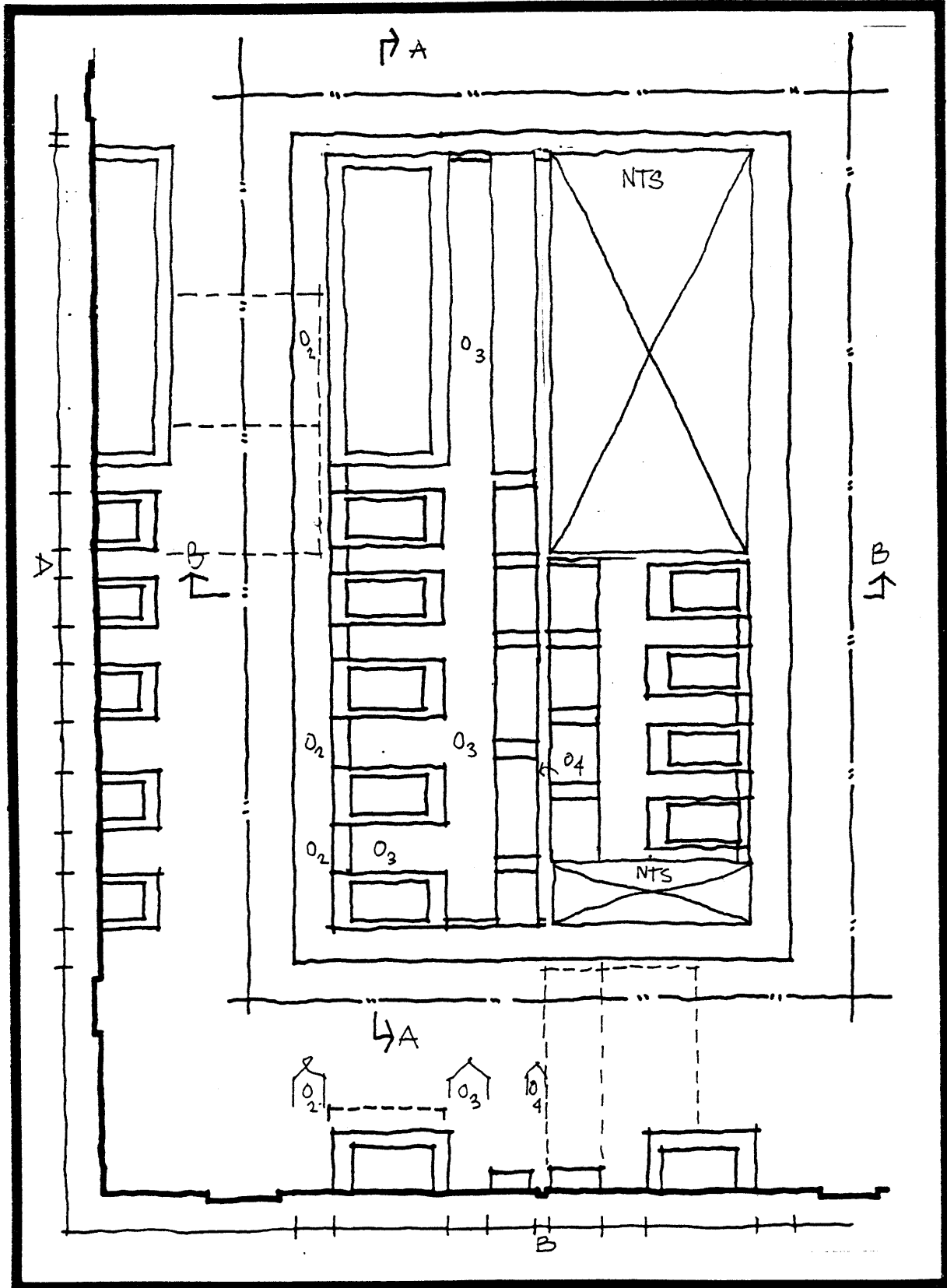

Figure 6-17

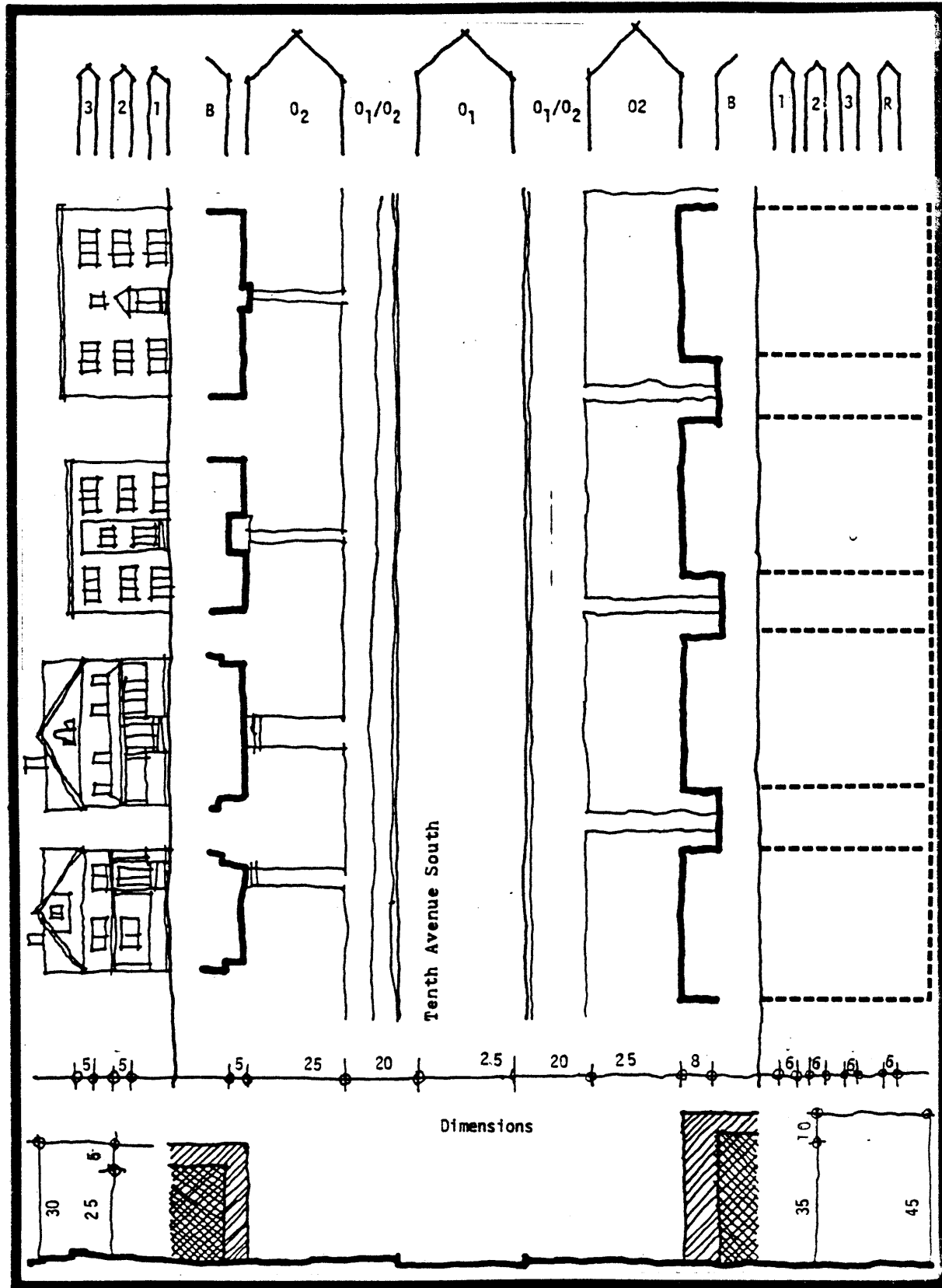

Figure 6-18

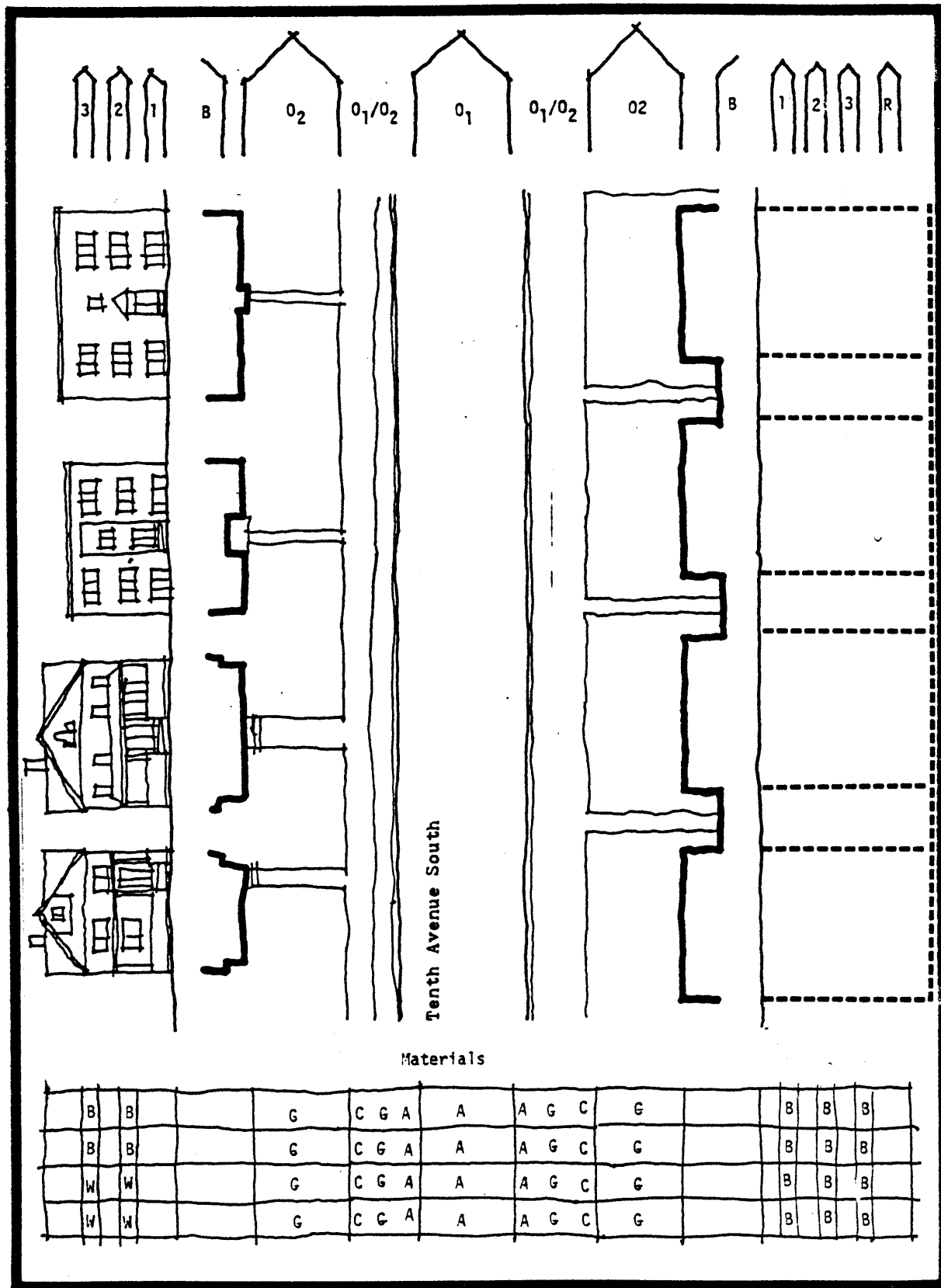

Figure 6-19

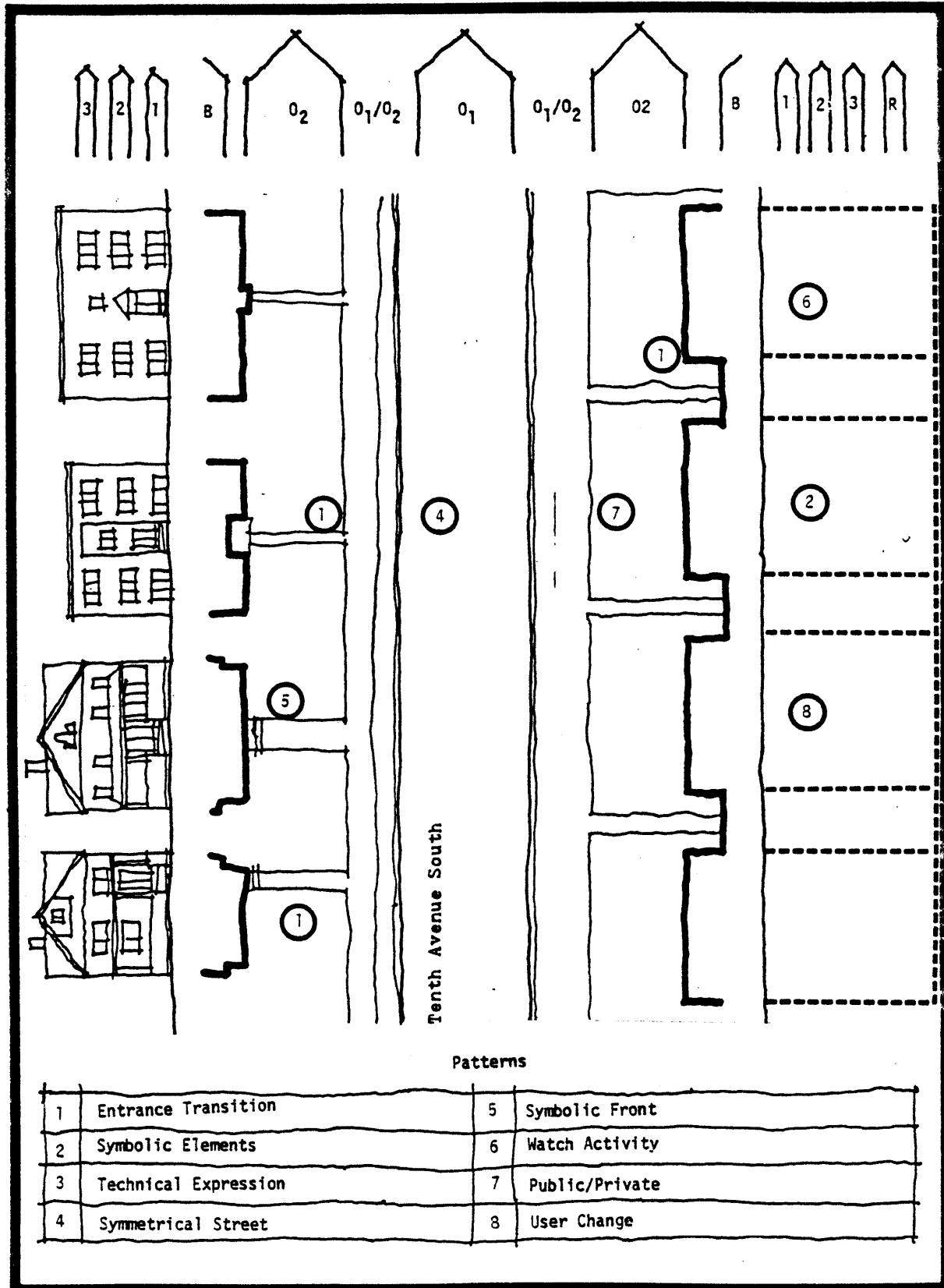

Figure 6-20

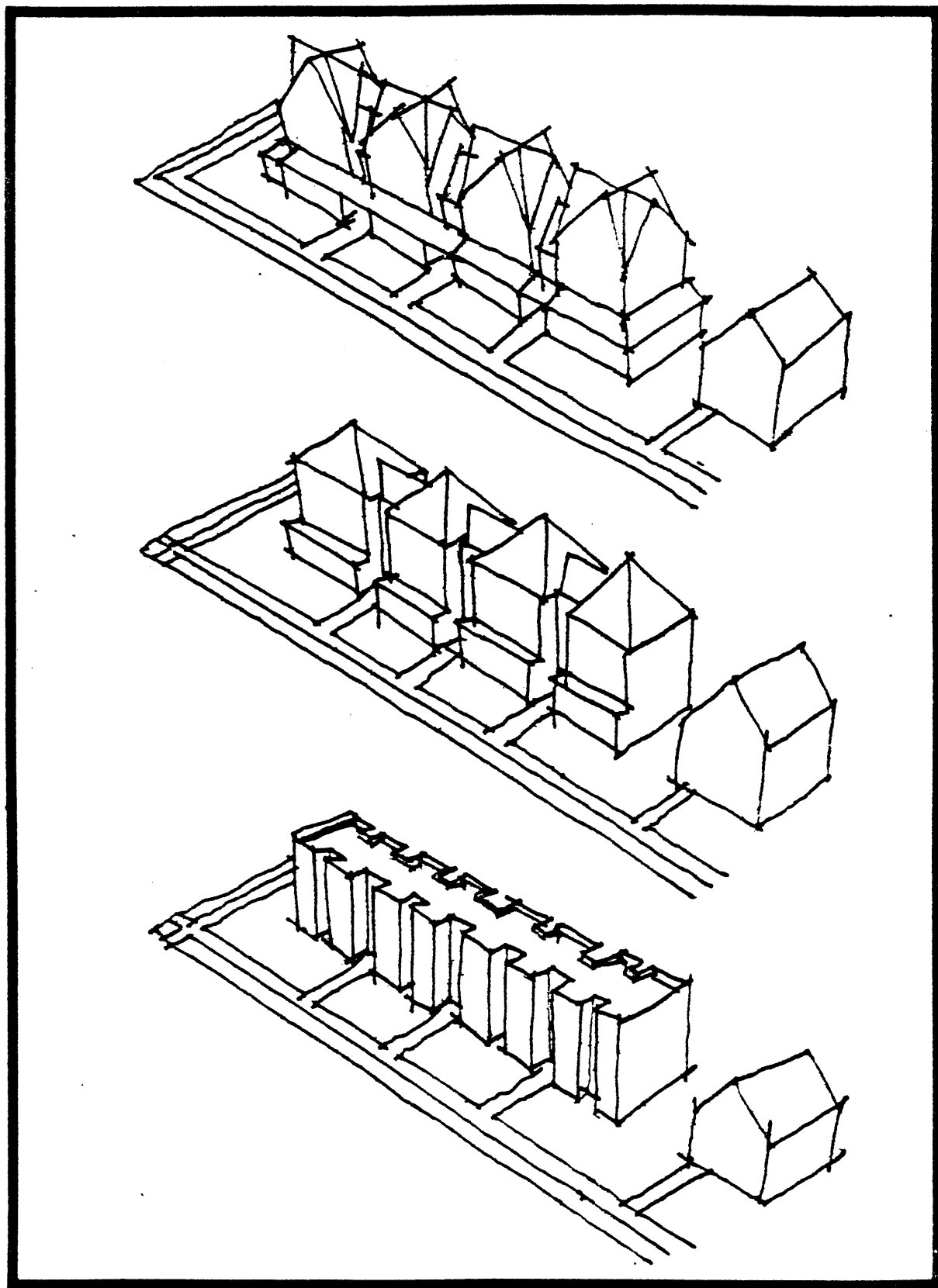

Figure 6-21

This study demonstrated the most conventional use of design guidelines which is to moderate the impact of development that contrasts too violently with the existing environment.

In this scenario, the building program at 1.85 FAR was less than the 2.1 FAR permitted by the zoning code. This enabled the building's square footage to be enclosed in a low-rise block similar to surrounding buildings. Without the height limits and the setback requirements of the block diagram, the same square footage could have been built into an elevator mid-rise and still satisfied the zoning requirements.

In a similar fashion, the pathway diagram encouraged characteristics unmentioned by the zoning code. Most notable are the roof forms and entry recesses that reflect the neighborhood housing patterns.

The application of guidelines in this instance would not require Level 2 actors. Urban designers assisting the community could organize the Level 3 block diagrams or the Level 4 pathway diagrams. With this documentation, the community representatives could work directly with the Level 5 Augustana nursing home representatives.

Chapter 7

The Ninth Street Greenway Special Design District (Replicate)

Step One:

The concept of the Ninth Street Greenway came out of earlier planning recommendations on the Elliot Park Neighborhood Plan. From an urban design standpoint, it was a logical concept which added to the present greenway structure started in the 1960's with the Nicollet Mall and the more recent greenway added with the new Loring Park Development District (see Figure 4-3). The proposed greenway would reunite Elliot Park, like Loring Park, with the city's pedestrian greenway system.

Coexistent with the proposed greenway is the last remnant of the city's brownstones which reflect the street-car inner-city housing construction. This housing form is unique in a city built with wood framed housing. These brownstones were systematically destroyed during the urban renewal era and during the gradual and indiscriminate expansion of the CBD over the last thirty years.

Now the brownstones are the object of interest by historical renovation groups. The community is planning to place them on the historical registrar, thus preventing their destruction. Because of the adjacent brownstone buildings just off Ninth Street, the opportunity exists for creating a special design district in the city to preserve the scale and the pedestrian quality of the brownstone housing. To maintain the brownstone scale, all dissimilar building forms should be altered or eliminated. The site for this study is one

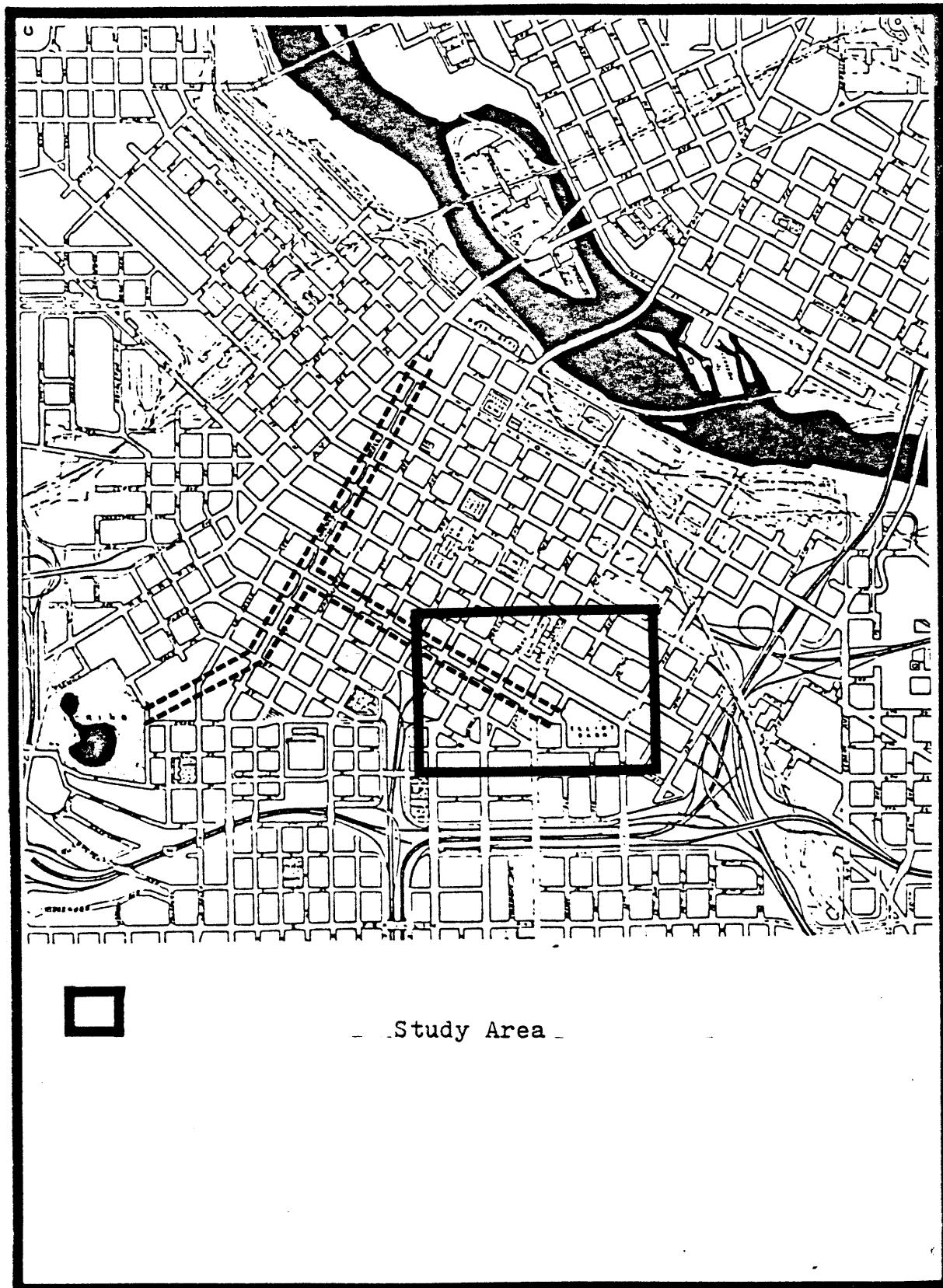

Figure 7-1

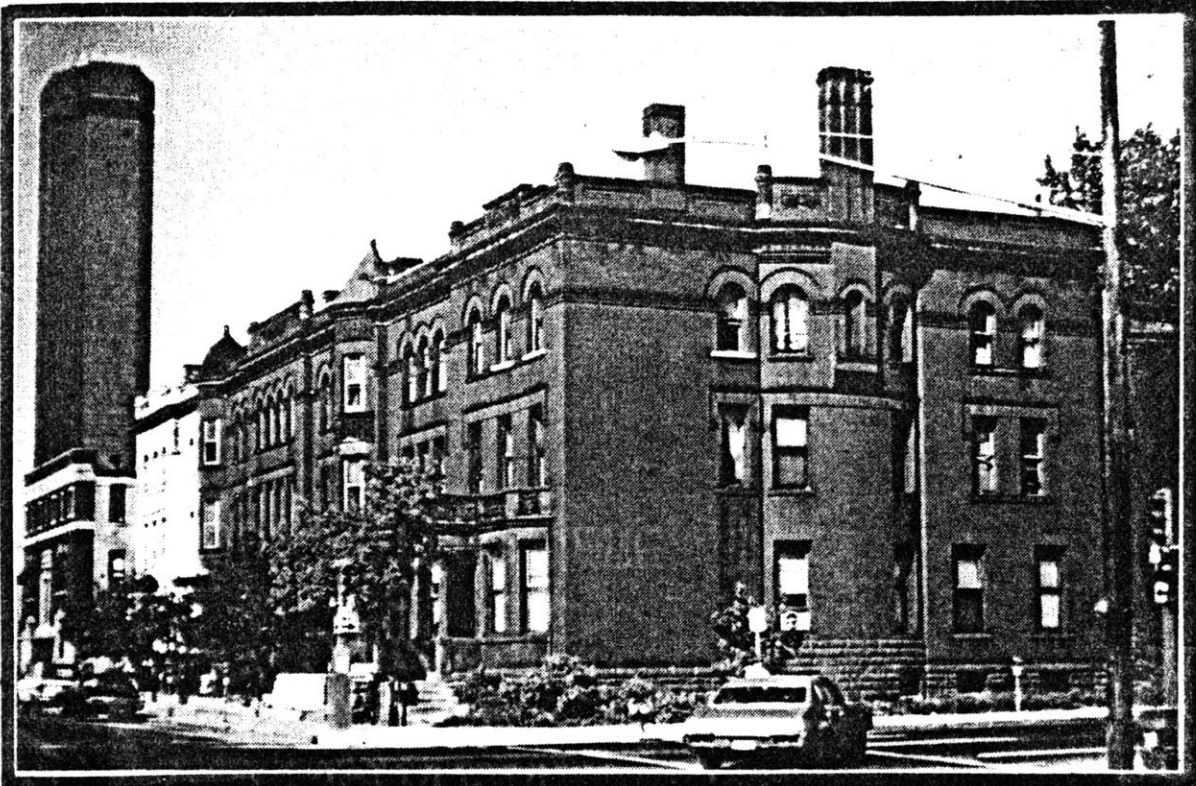

Figure 7-2

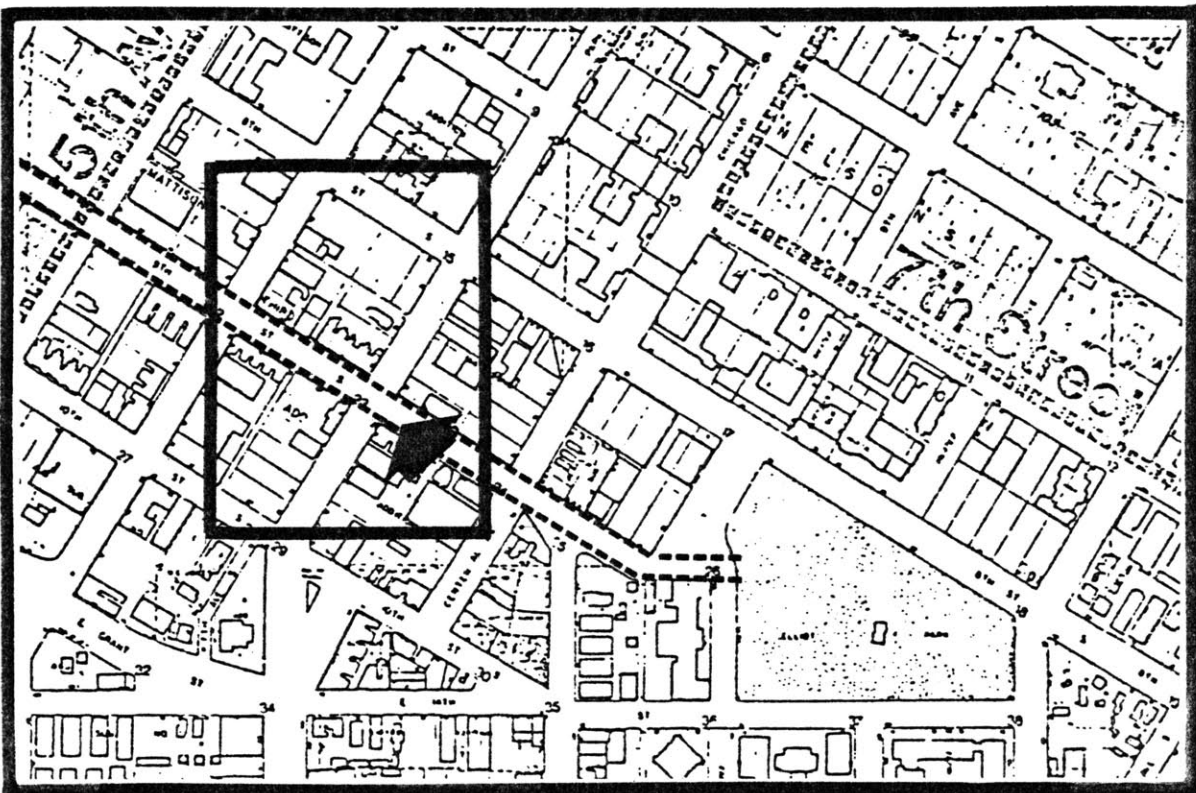

Figure 7-3

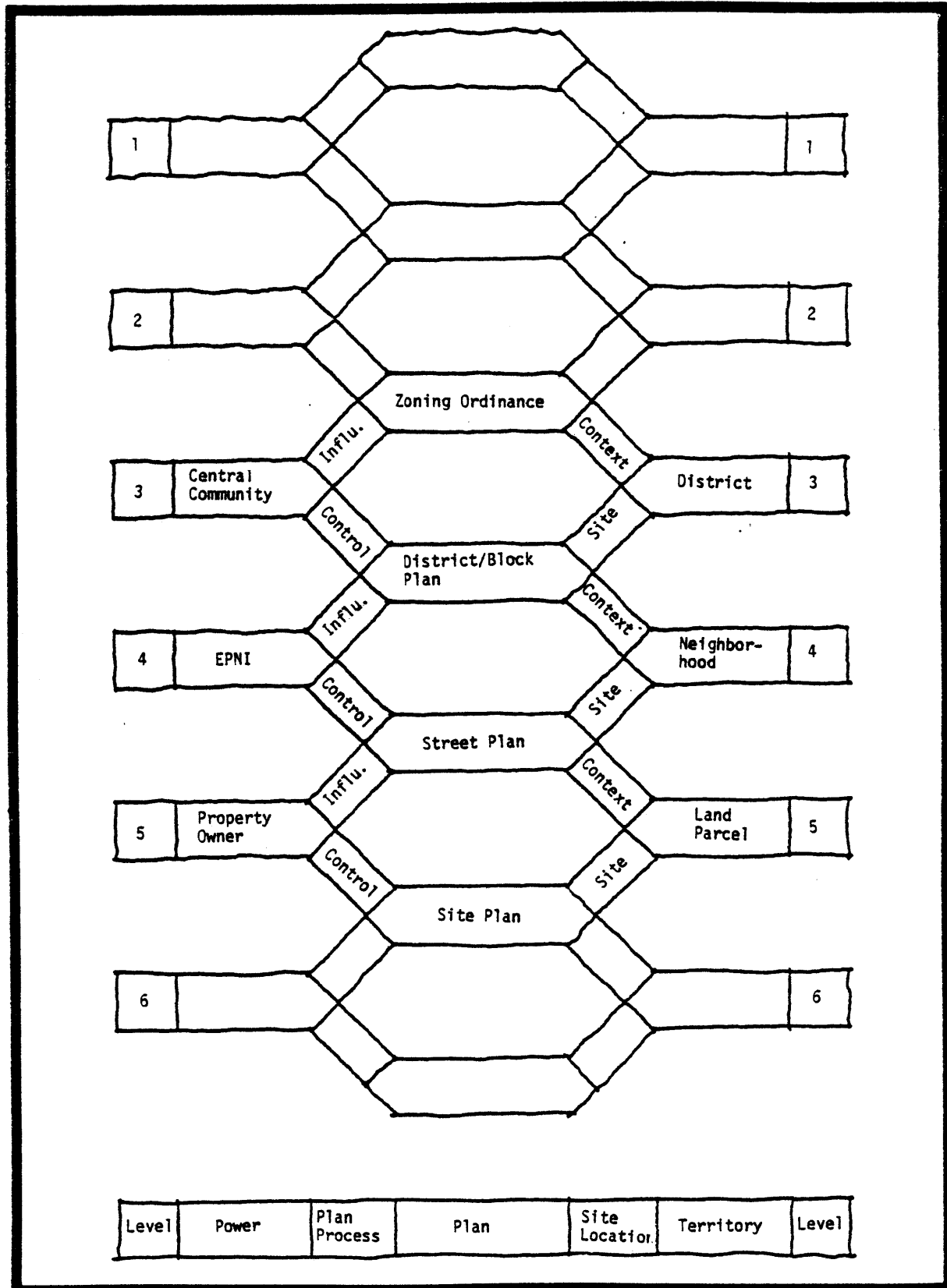

Figure 7-4

presently occupied by a manufacturing building and an older railroad corridor apartment building that is incompatible with the adjacent row housing.

Developing the Ninth Street Greenway holds opportunities for developing a design district in the surrounding area. The greenway draws attention to the opportunities for pedestrian corridors of the inner-city residents, free from the suburban commuter traffic which has destroyed inner city pedestrian streets. Creating a design district in the city will increase its property values, create another distinct inner city neighborhood, and will implement an increasingly common urban design mechanism for preserving older environments. In doing so the city could have a district in town that could resemble Boston's Back Bay in its successful 19th century urban pedestrian quality.

Step Two

Prepared by urban designers working with the Elliot Park Neighborhood Incorporated (EPNI). This step includes the following:

1. Identification of existing block. Figure 7-5
2. Identification of block parcels. Figure 7-6
3. Identification of block model (B). Figure 7-7
4. Identification of block model (O). Figure 7-8

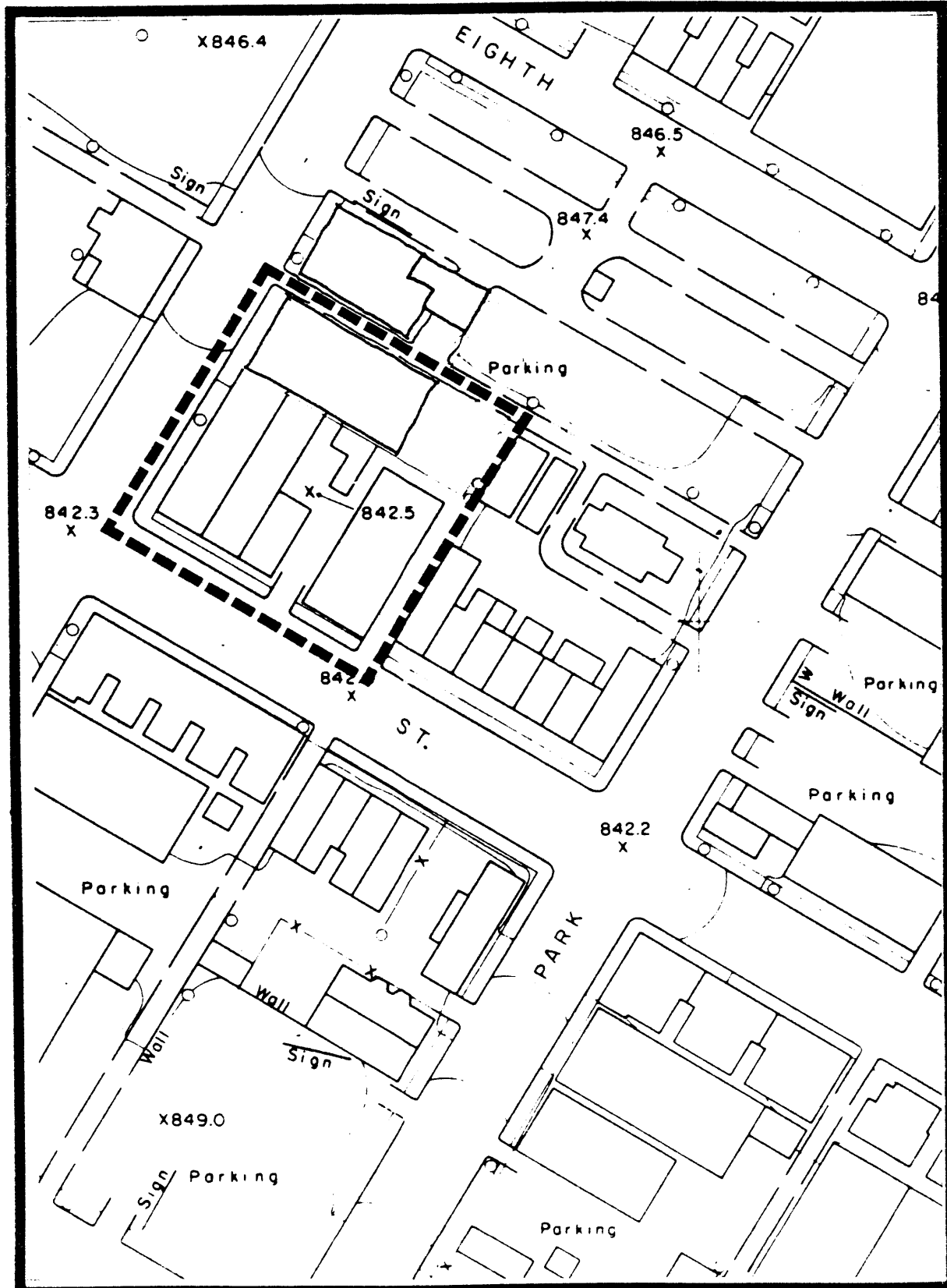

Figure 7-5

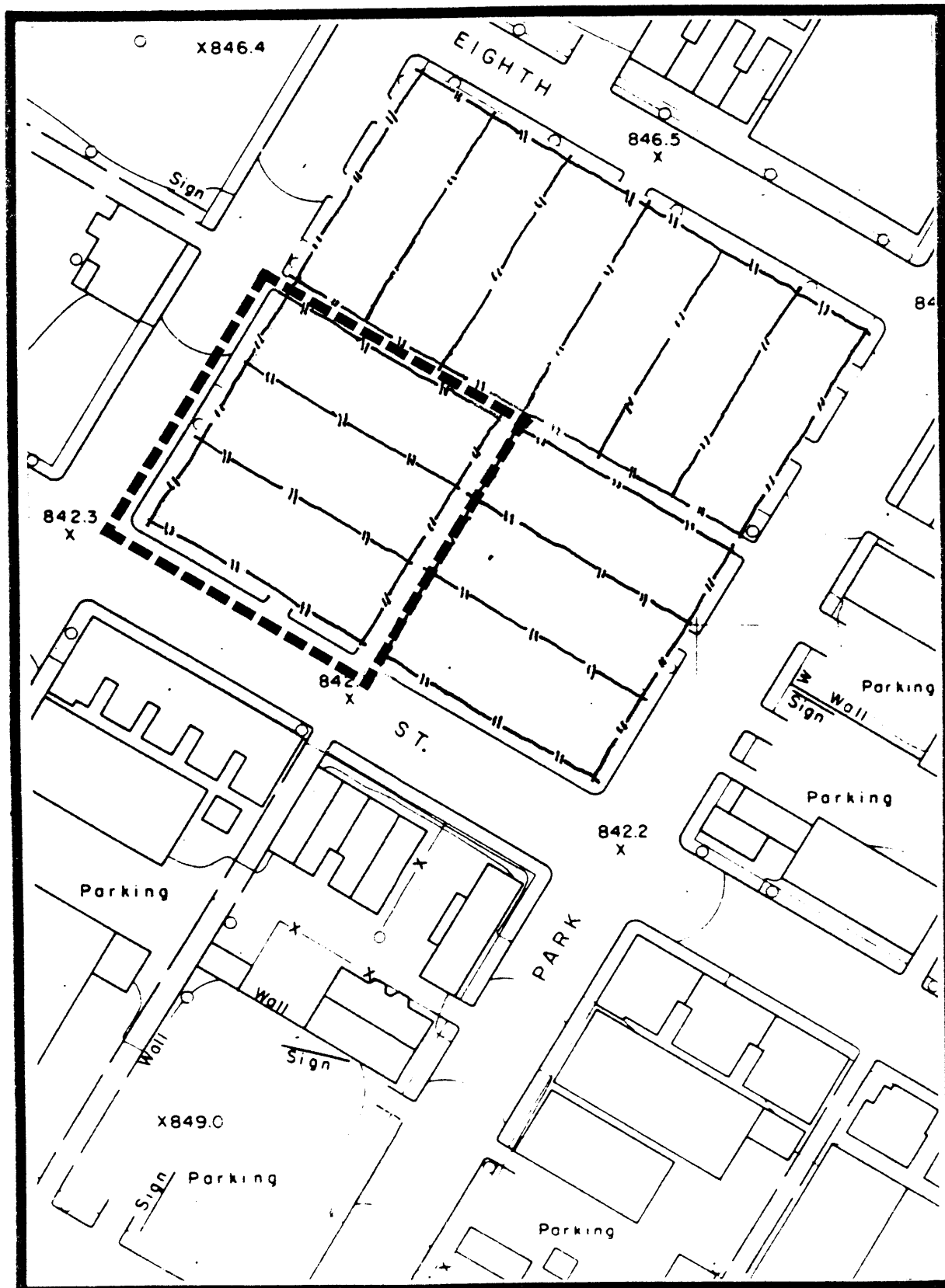

Figure 7-6

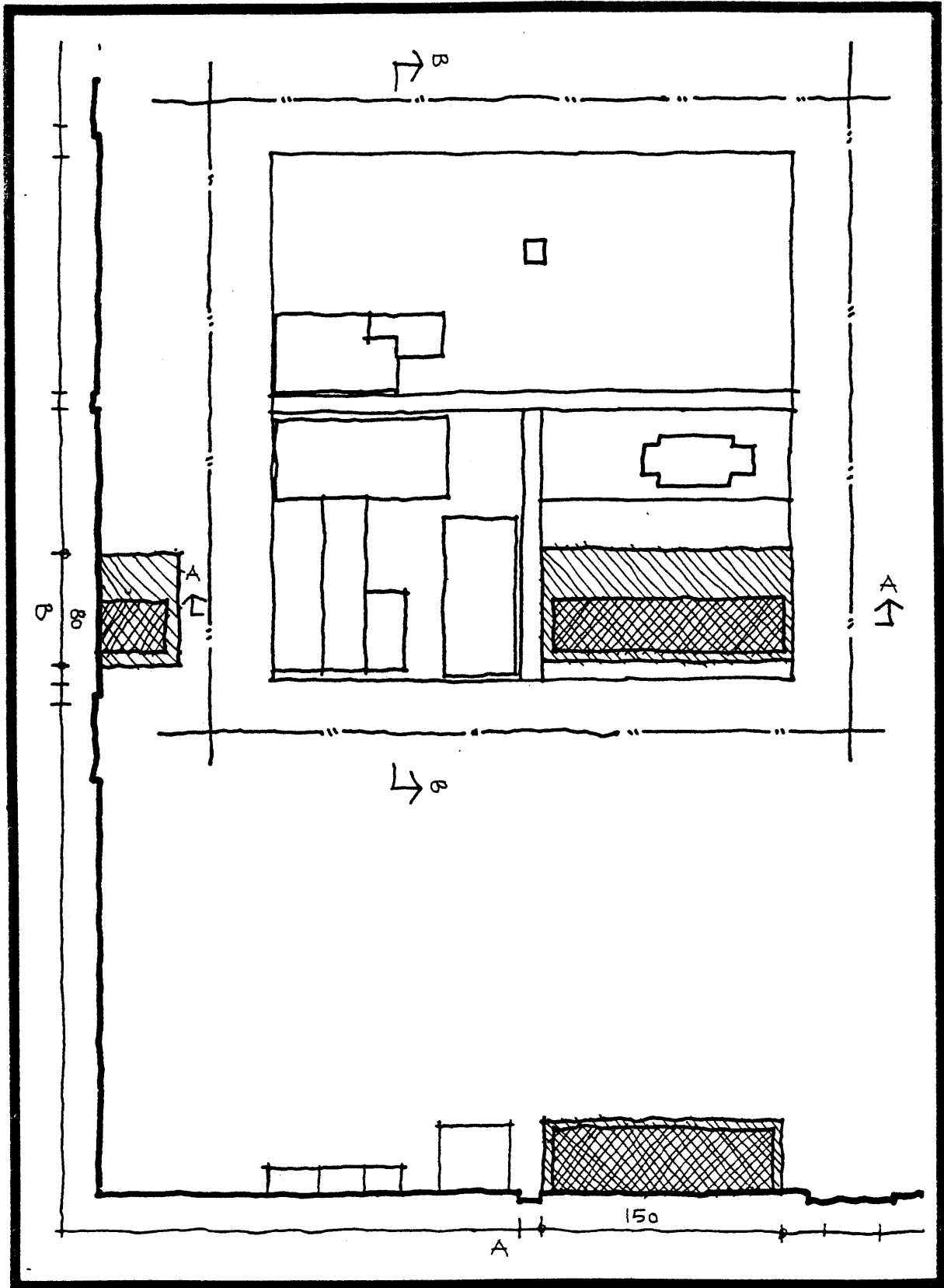

Figure 7-7

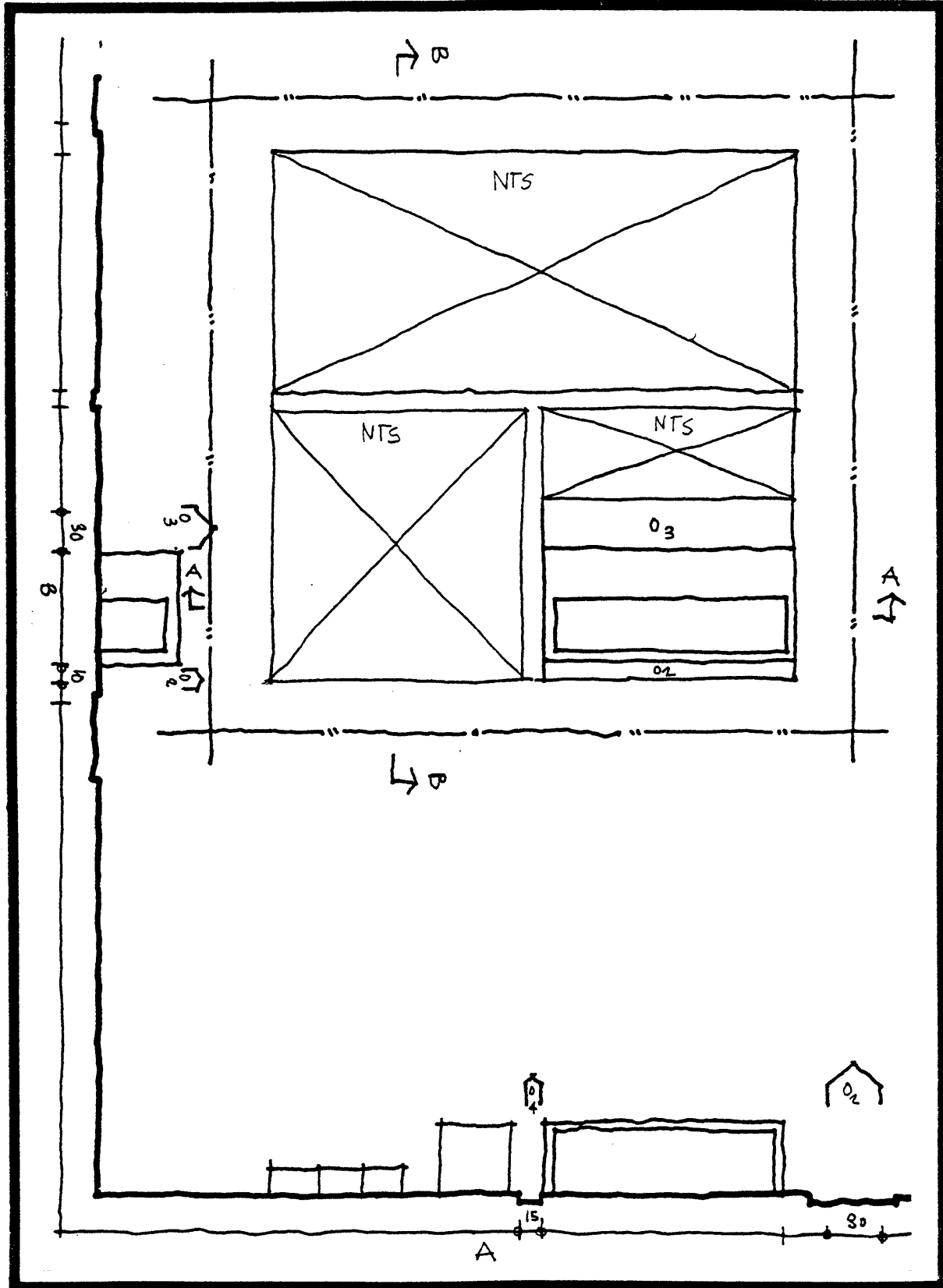

Figure 7-8

Step Three

Prepared by urban designers working with the Elliot Park Neighborhood Incorporated (EPNI) and block residents living in the environs of the site. It includes the development of the three pathway diagrams developed by the above groups through participatory processes:

1. Regulatory diagram Figure 7-9
2. Materials diagram Figure 7-10
3. Pattern diagram (existing) Figure 7-11

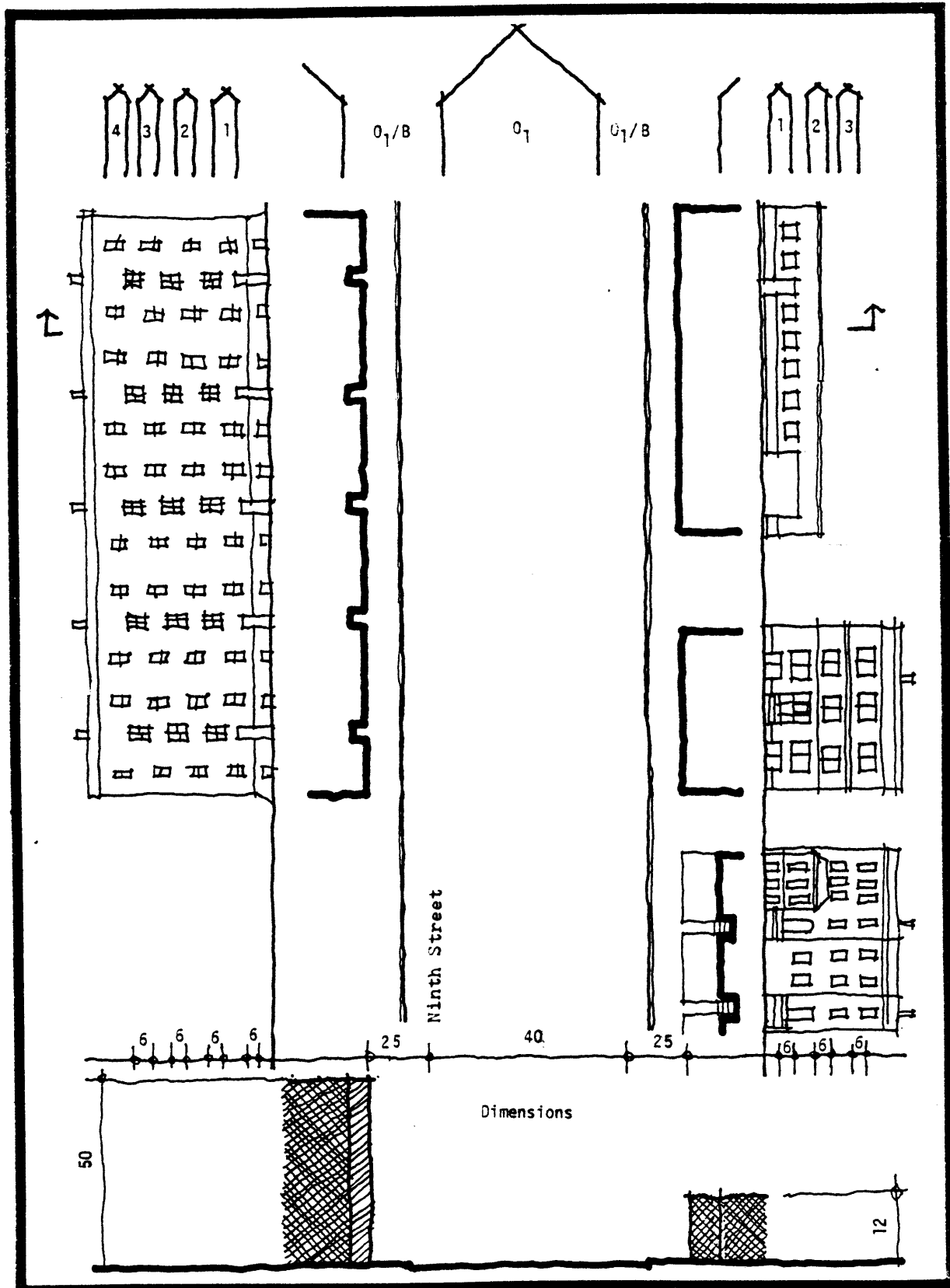

Figure 7-9

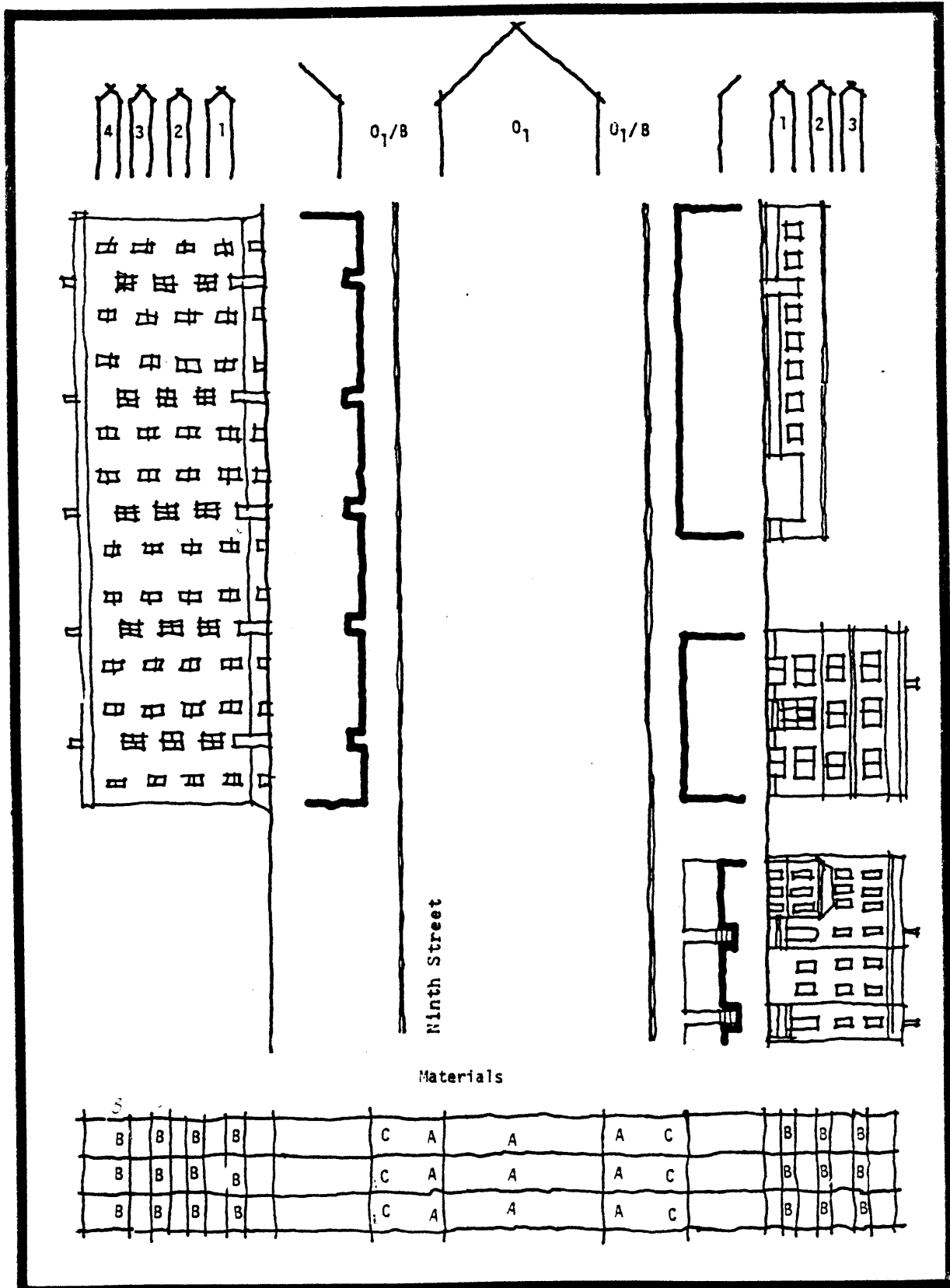
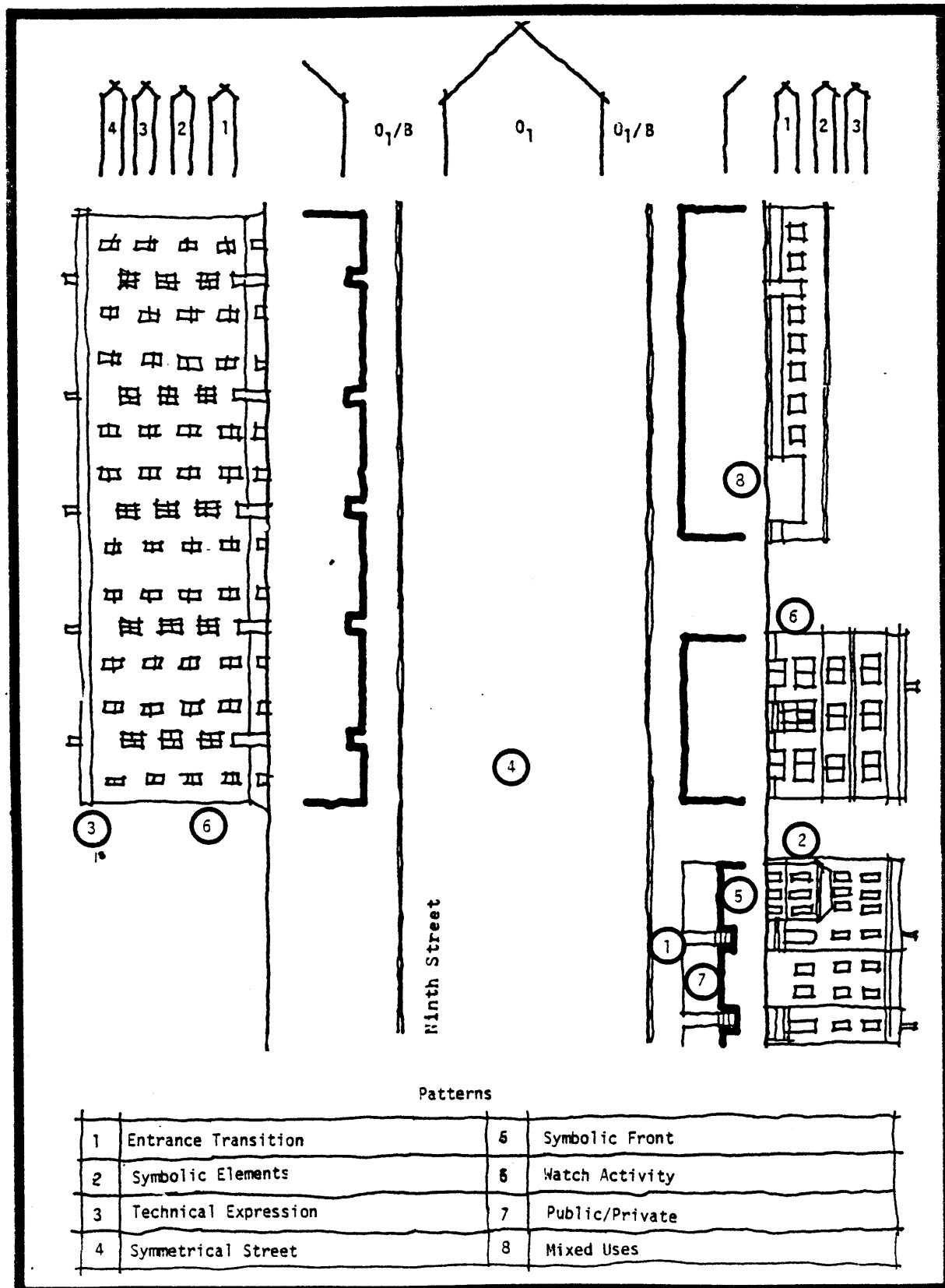

Figure 7-10



Patterns

1	Entrance Transition	5	Symbolic Front
2	Symbolic Elements	6	Watch Activity
3	Technical Expression	7	Public/Private
4	Symmetrical Street	8	Mixed Uses

Figure 7-11.

Step Four

The parcel/program analysis is prepared by the urban designers working with the Elliot Park Neighborhood Incorporated (EPNI).

The analysis includes the following steps:

1. Description of the building program. Figure 7-12
2. Description of the site area. Figure 7-12
3. Identification of zoning requirements. Figure 7-13, 7-14
 - a. lot size requirements
 - b. yard requirements
 - c. building bulk limitations (identification of FAR premium if applicable)
 - d. off-street parking
 - e. off-street loading

Building Program: 200 DU Apartment Building
with First Floor Rental Space and Attached
Parking Garage.

1. 150 1 BR Appartments at 750 SF	112,000 SF
2. 50 2 BR Appartments at 900 SF	45,000 SF
3. Rental Space	5,000 SF
4. Circulation at 10%	<u>16,200 SF</u>
Total	178,200 SF

Site Area:

1. 180 FT x 180 FT	32,000 SF
--------------------	-----------

Expected FAR:

$$\frac{178,200 \text{ SF}}{32,000 \text{ SF}} = 5.6 \text{ FAR}$$

Fire Zone:

II

Figure 7-12

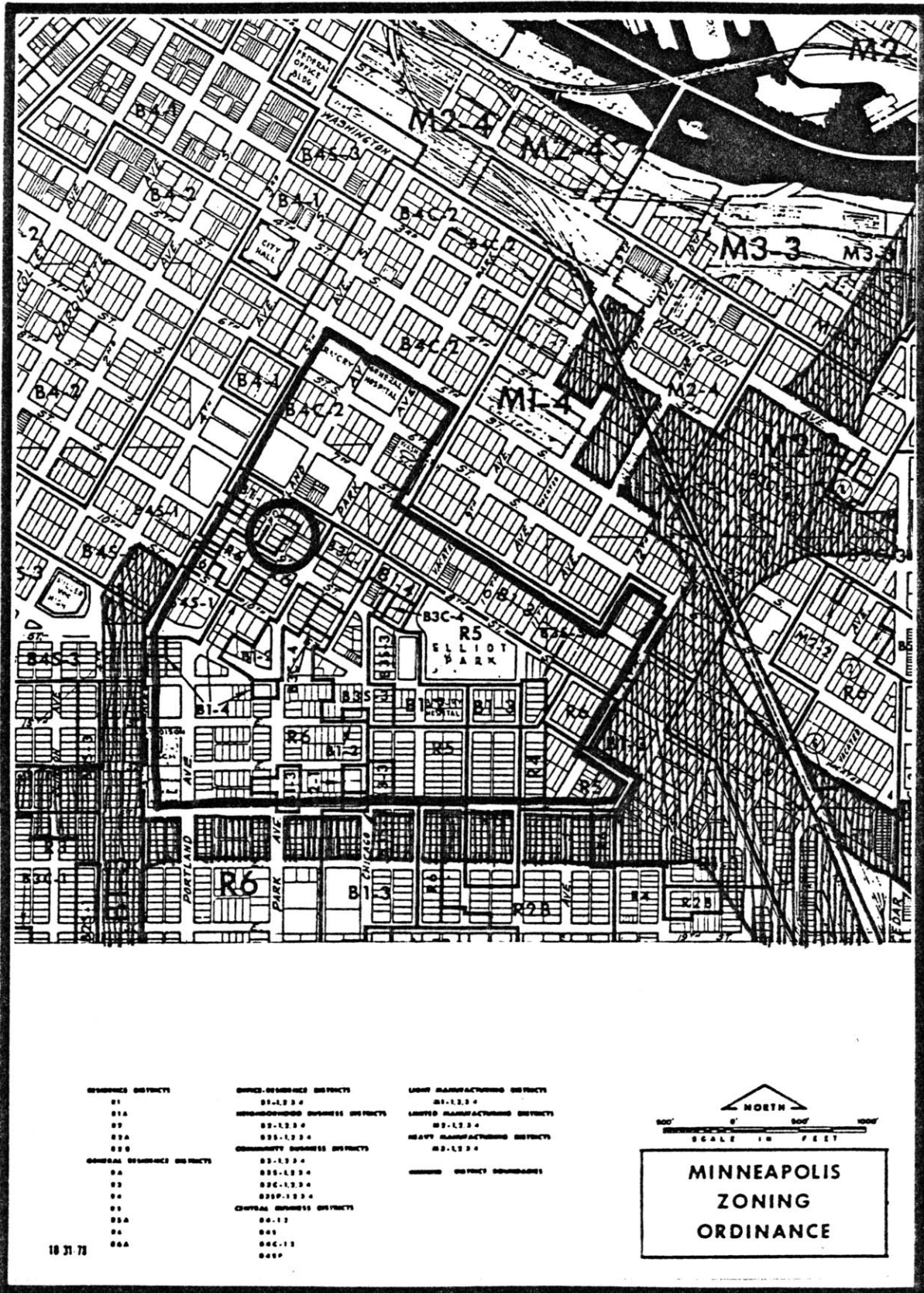

Figure 7-13

Zoning Requirements:	B4S -3	
Lot Size Requirements		None
Yard Requirements		
1. Front:		None
2. Side:		
5 FT + 2 x 20 Floors		45 FT
FAR:		10
FAR Premiums:		
1. Park Premium		1
2. Sidewalk Canopy		2
3. Parking Garage Connection		2
4. Off Street Service Loading		2
5. Off Street Pedestrian Loading		2
6. Off Street Paking		2
7. Plaza , Setback, and Sidewalk Arcade		2
8. Internal Arcade		4
		<hr/>
Total Possible FAR with Premiums		27
Off Street Parking:		
90% x 200 dwelling Units = 180 Spaces		
300 SF x 180 Spaces		54,000 SF
Off Street Loading		600 SF

Figure 7-14 _ .

Step Five

This step is the review of the previous four steps and identifies the community's position for concept plan review with the City Planning Commission and the developer. These design guidelines are made up of the following information:

1. Parcel identification Figure 7-15
2. B analysis Figure 7-16
3. O analysis Figure 7-17
4. Pathway diagrams Figure 7-18, 7-19, 7-20
5. Massing options consistent with the above Figure 7-21

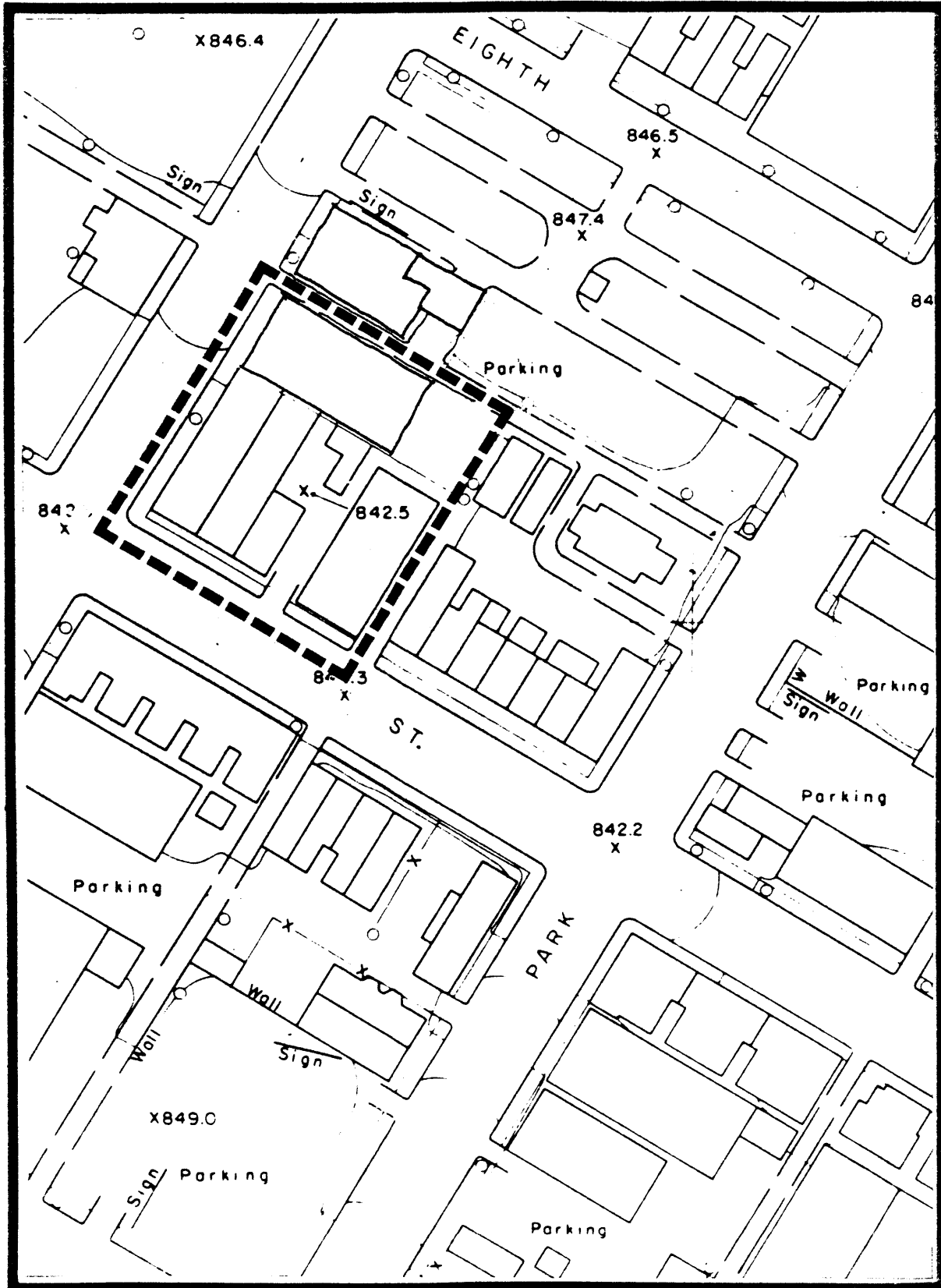

Figure 7-15

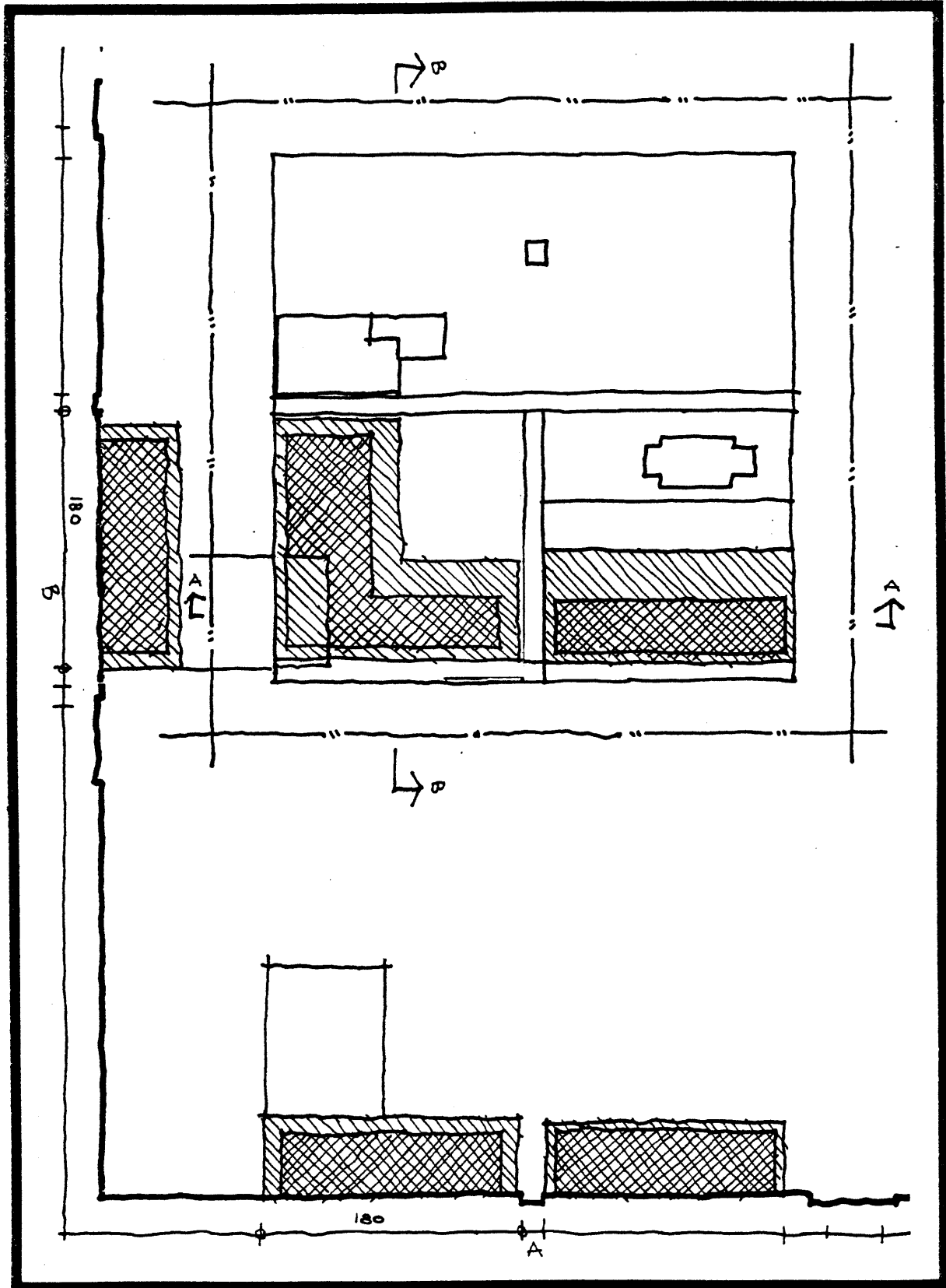

Figure 7-16

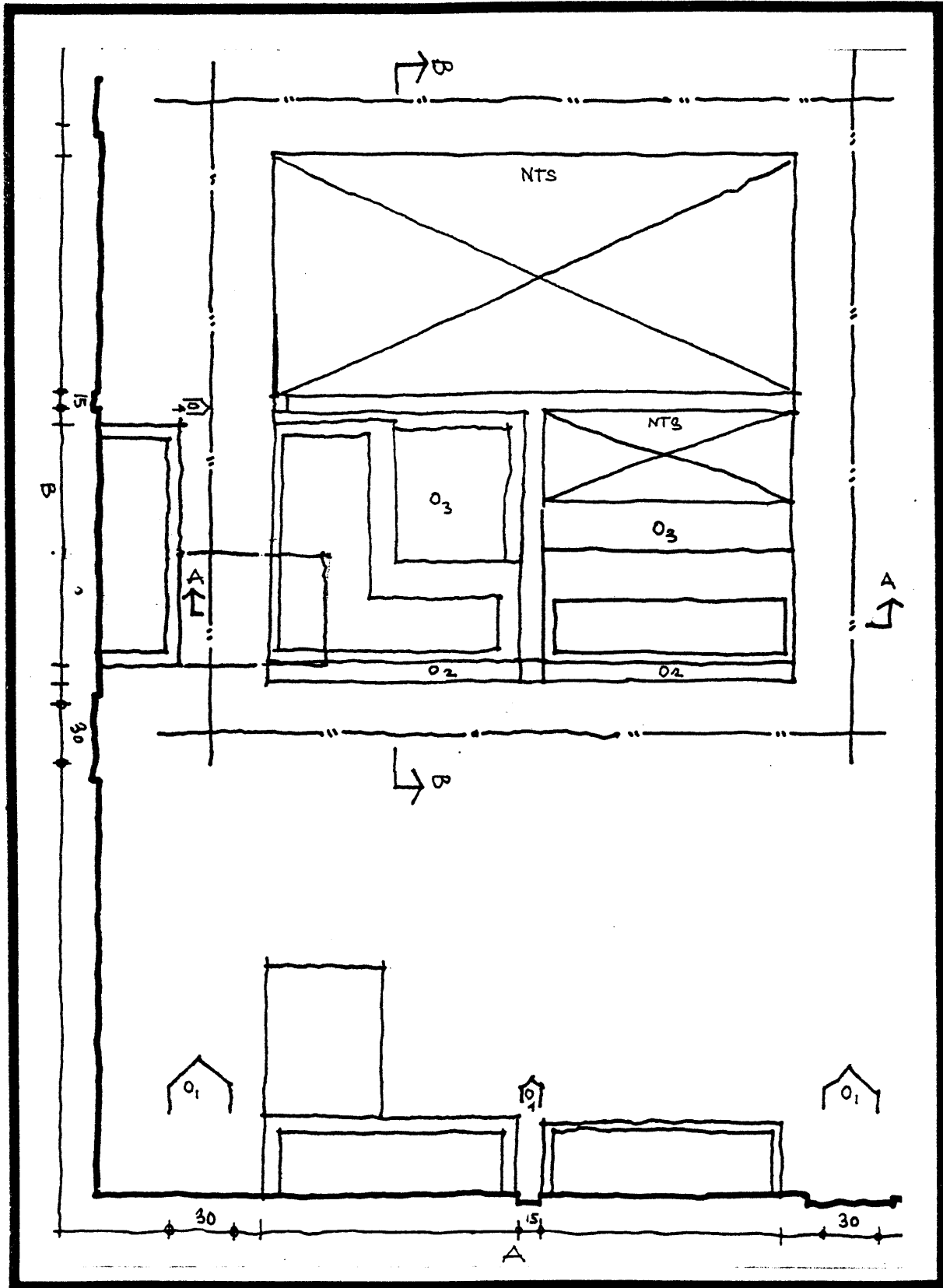

Figure 7-17

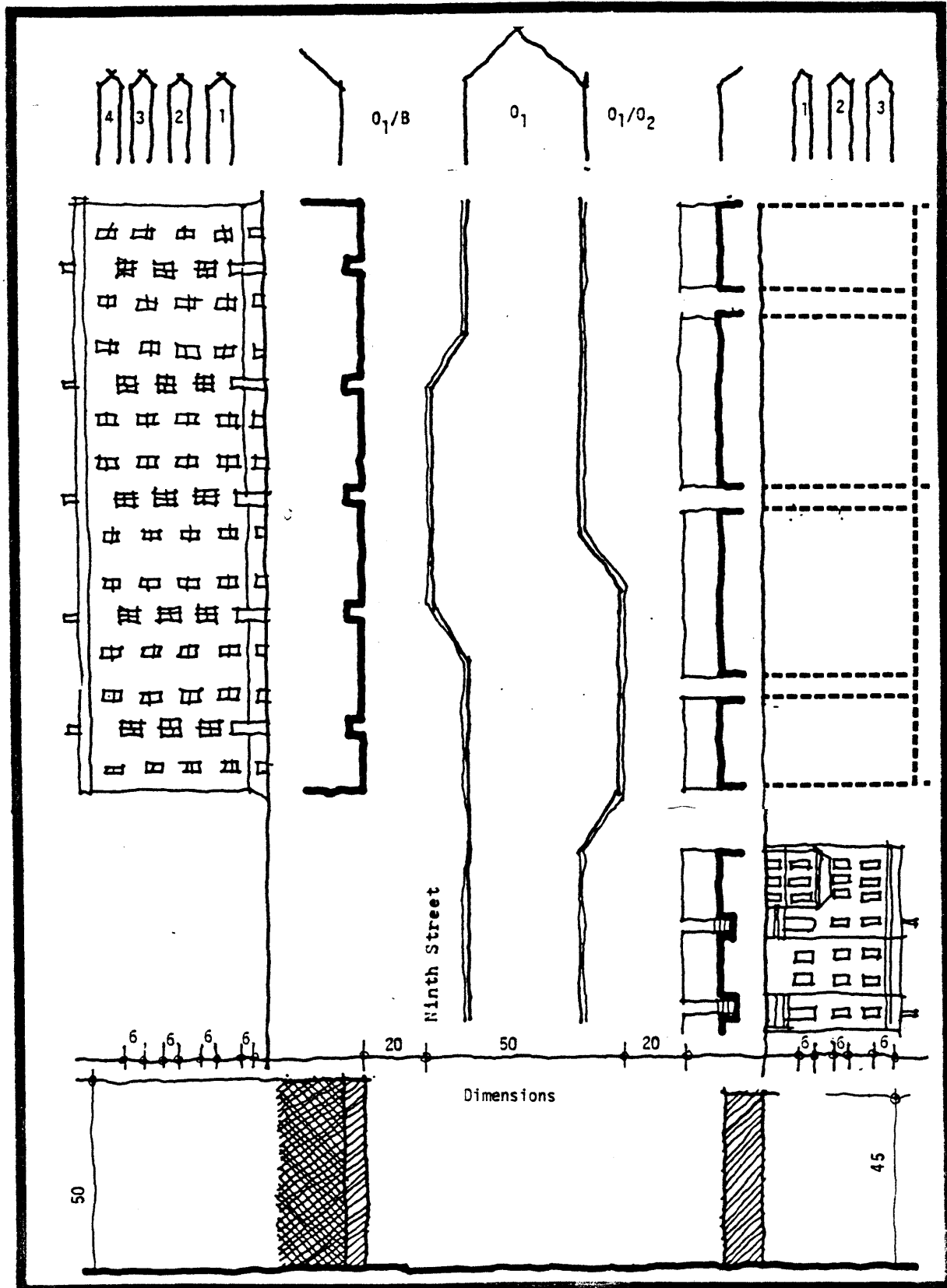

Figure 7-18

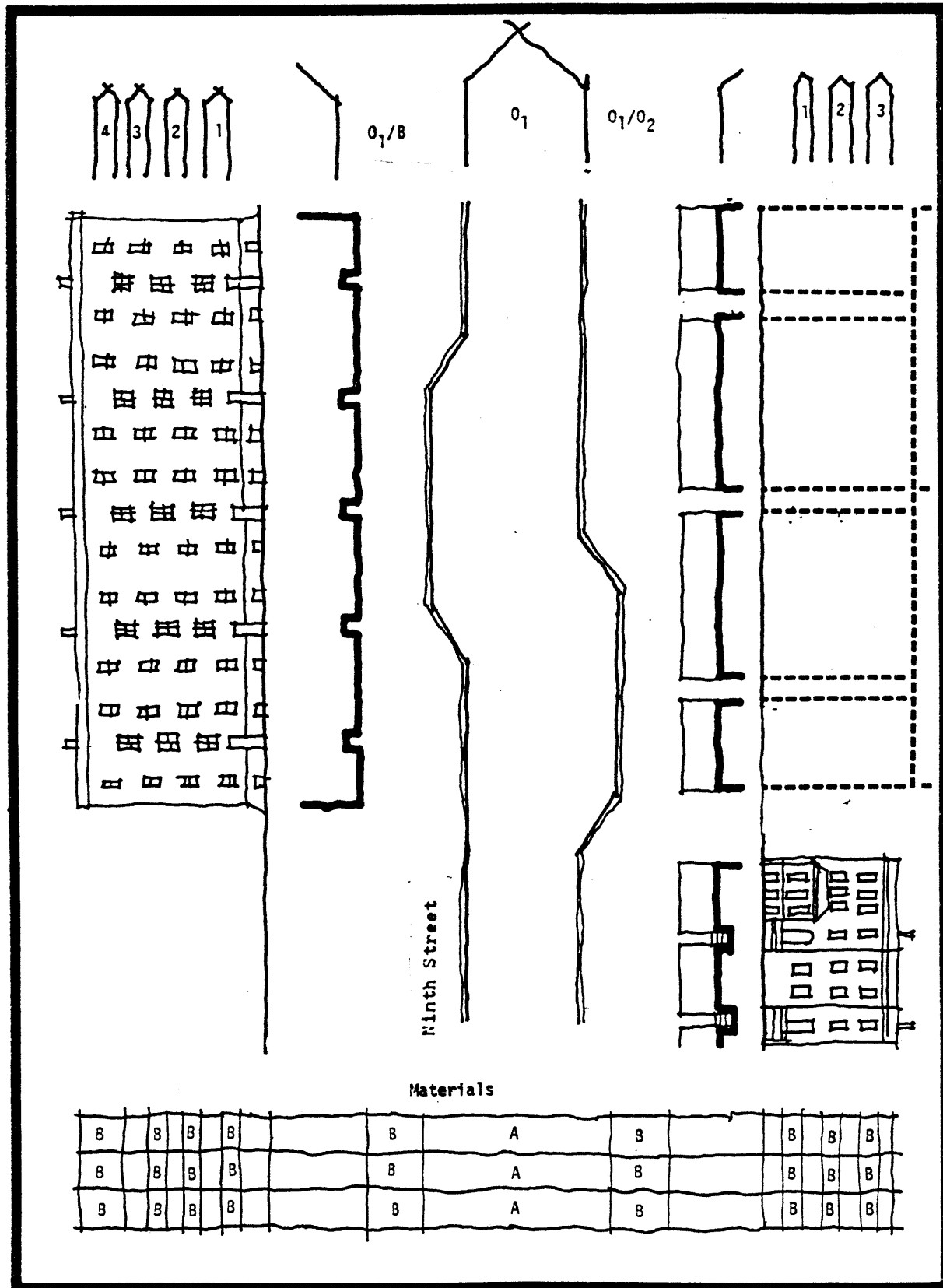

Figure 7-19

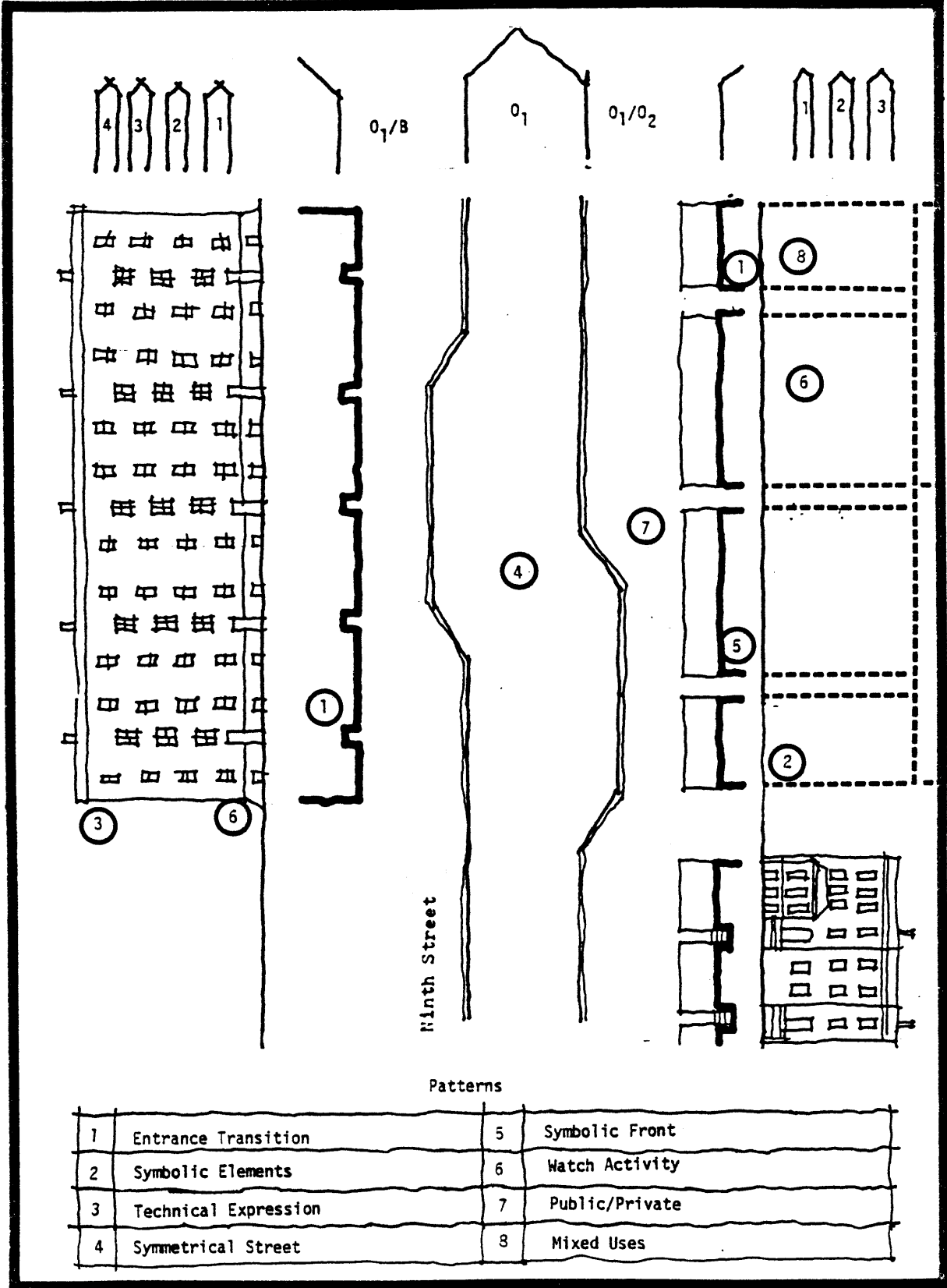

Figure 7-20

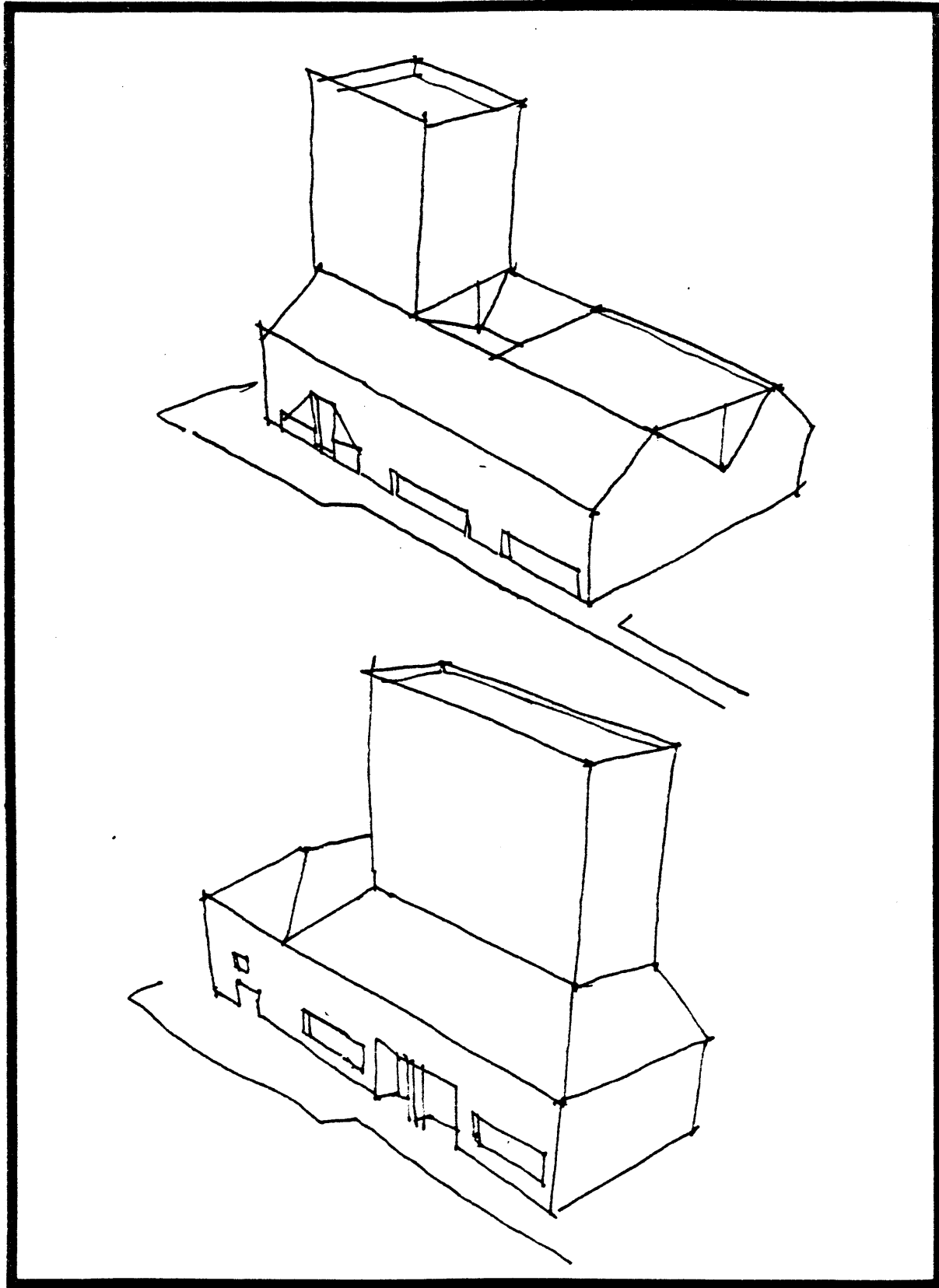

Figure 7-21

In this example, the design guidelines were used to promote a desirable design district for housing adjacent to the CBD. In the development, Elliot Park community would have a direct pedestrian linkage with the downtown via the Ninth Street mall.

This example used the zoning requirements in existence before the 1978 Elliot Park rezoning. This was done just to demonstrate the potential impact of the Radiant City FAR premiums. In this case the normal FAR 10 could be raised to FAR 27 if all the premiums were used (see Figure 7-14). The building program, however, utilized only one half the potential FAR with FAR 5.7.

Assuming that Level 2 decision makers were in favor of this design district proposal, the district level block diagram would be used to regulate building height (cornice line) and setback so that it would be compatible with the adjacent historical structure. The block diagram would locate but not regulate the residential apartment tower. This fact points a potential failing of the block diagram. It is best at organizing the orthogonal Block City model with building masses to eight stories. As a result it can only regulate the base of taller buildings, but not the elevator towers themselves.

The pathway diagrams in this instance insured that the dimensions, materials, and patterns of adjacent structures were used in the new construction. In addition, the pathway diagram helped to organize the 01/02 margin along the pedestrian mall to private vehicle parking and stop off points for loading and unloading.

This exercise demonstrates the most speculative use of the design guidelines: to help create images for future development.

Once the design district was organized, the guidelines would be useful in regulating projects proposed by developers.

Finally, the guidelines help Level 3 and 4 actors in the following ways: to promote a desired pedestrian way, to demonstrate graphically how new construction can be compatible with adjacent buildings, and to call attention to the importance of preserving historical buildings as part of the urban mosaic.

Chapter 8

Elliot Park East (Initiation)

Guidelines can also encourage neighborhood sponsored development in land that is presently under-utilized. Such a case is in Elliot Park East, the area on the east side of the park now surrounded by institutions to the south, west, and north.

In order to evolve greater development of the area, it is necessary to develop the enclosure of the park so as to reinforce its urban quality. The enclosure should reflect the characteristic heights of the adjacent institutions in a relatively uniform fashion. In addition to the enclosure, it would be necessary to experiment with mixed use development, so that housing, commercial and office uses can be combined in this near CBD location.

Using this timeless formula of first story commercial with housing/office above, the new construction would be along the major pedestrian corridor to the new stadium. The guidelines would help channel the commercial speculation that will come with the new stadium development.

The housing programs explore the air rights over a Dairy Queen, which is closed seasonally between October and April of each year. By developing housing over the Dairy Queen, the community would gain better use of the parking areas as well as provide customers to the commercial fast-food chain store, making year-round operation more viable.

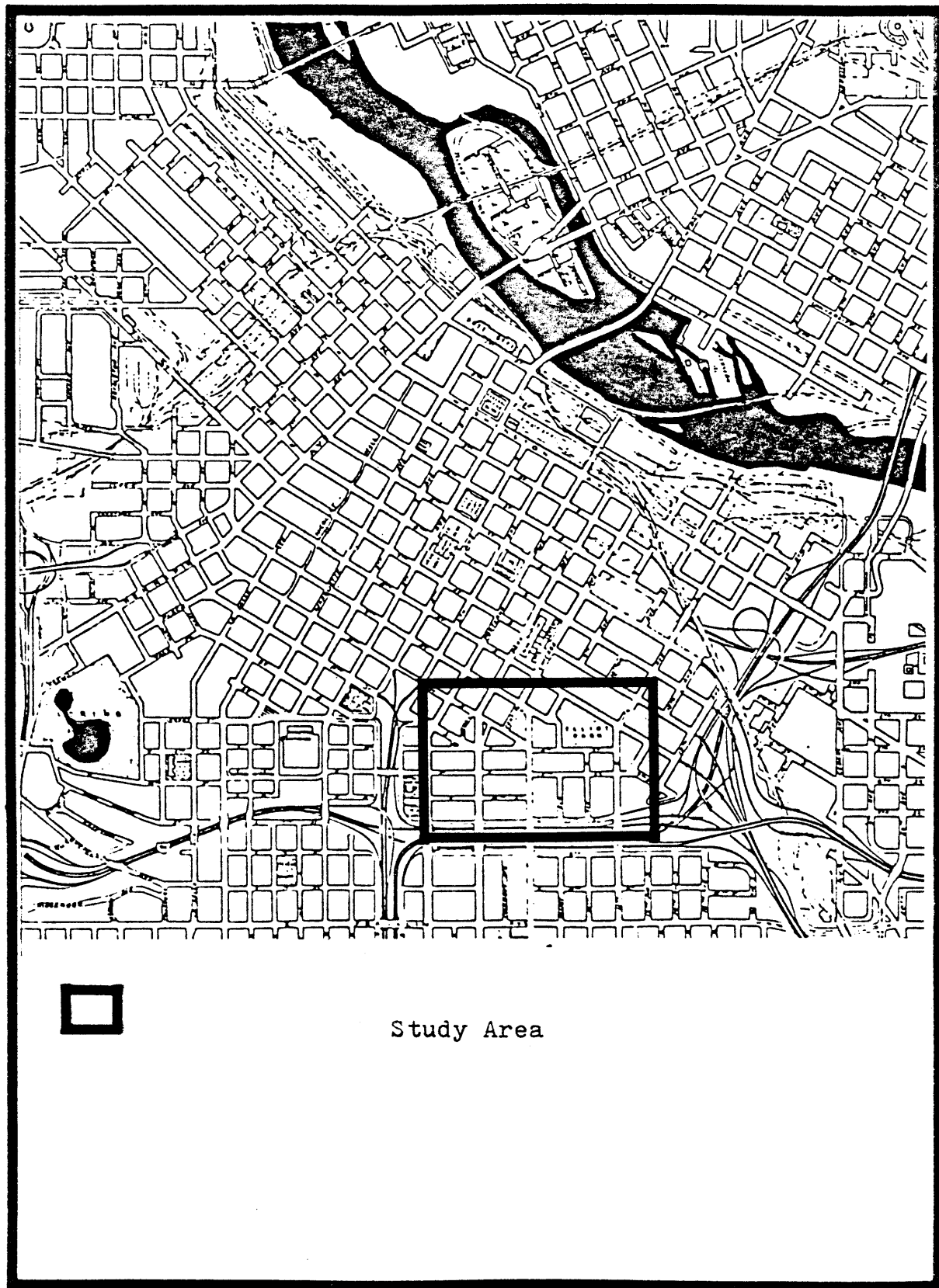

Figure 8-1

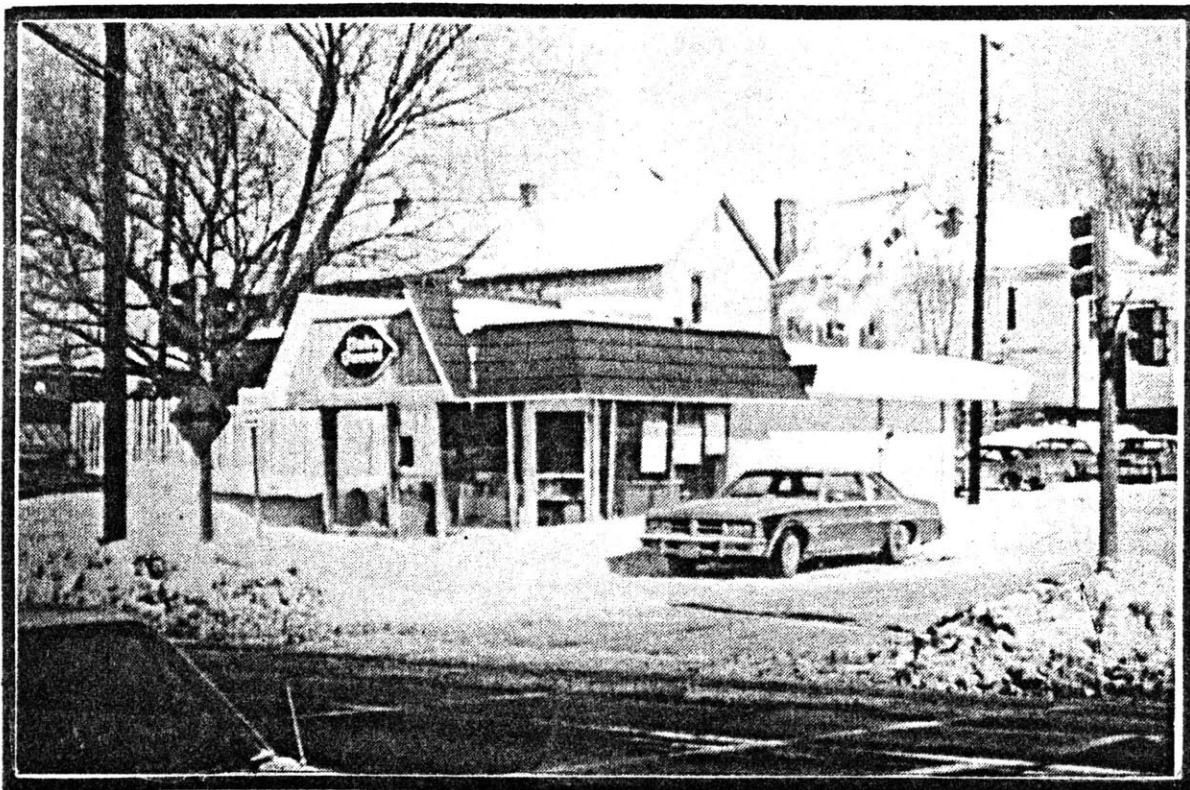

Figure 8-2

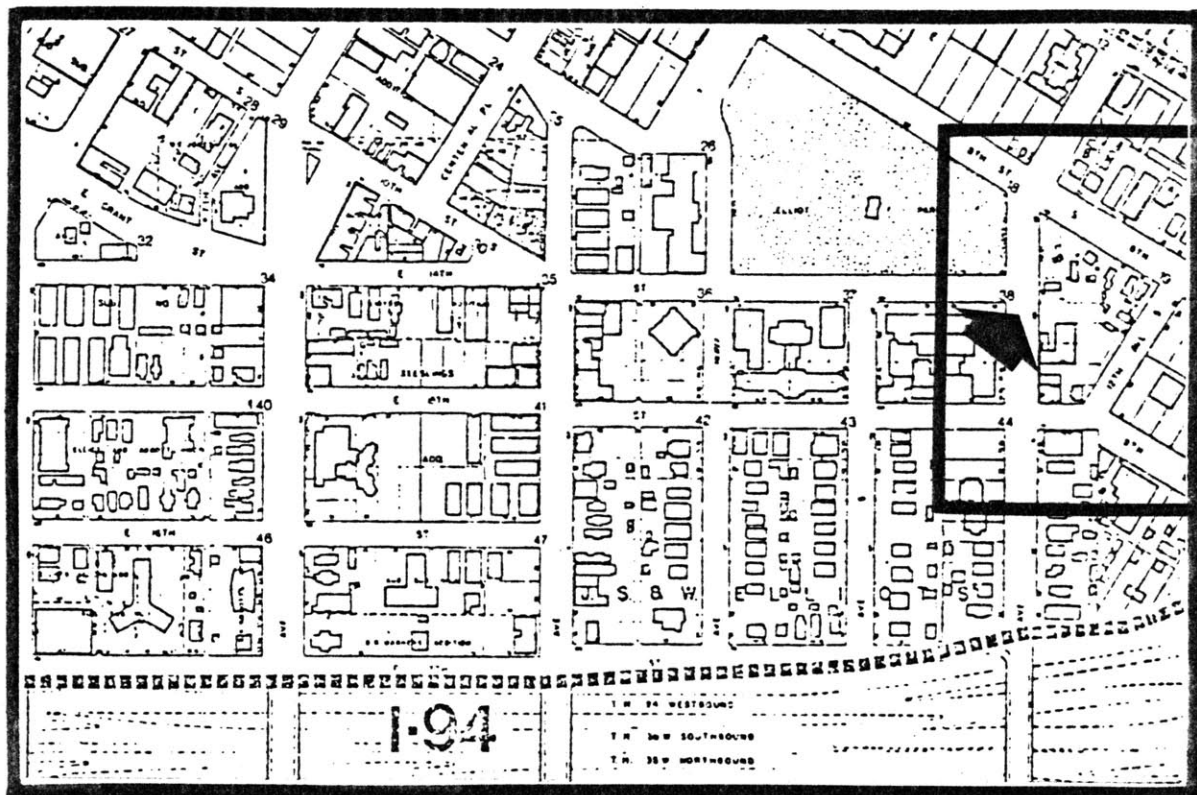

Figure 8-3

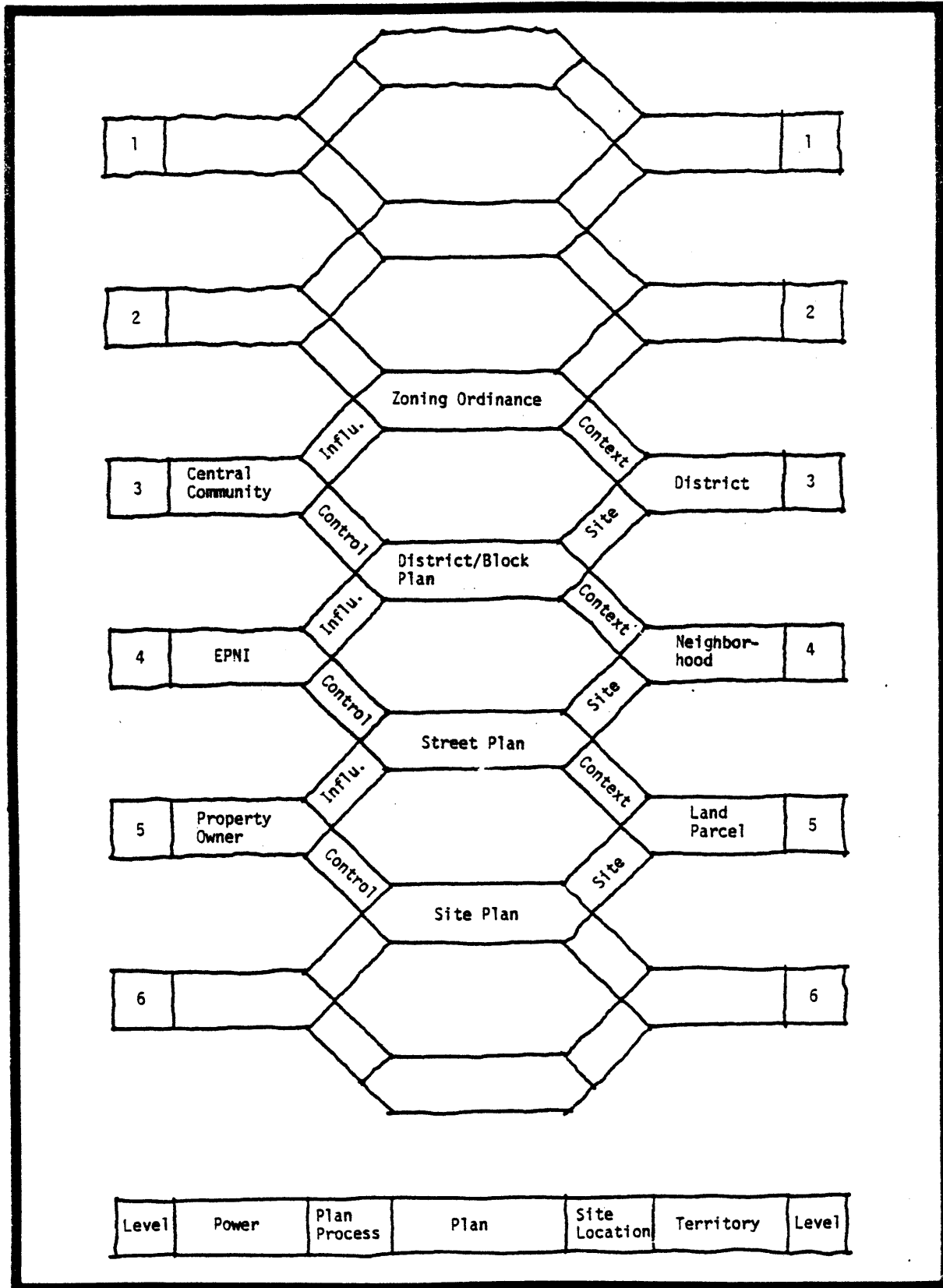

Figure 8-4

Step Two

Prepared by urban designers working with the Elliot Park Neighborhood Incorporated (EPNI). This step includes the following:

1. Identification of existing block. Figure 8-5
2. Identification of block parcels. Figure 8-6
3. Identification of block model (B). Figure 8-7
4. Identification of block model (O). Figure 8-8

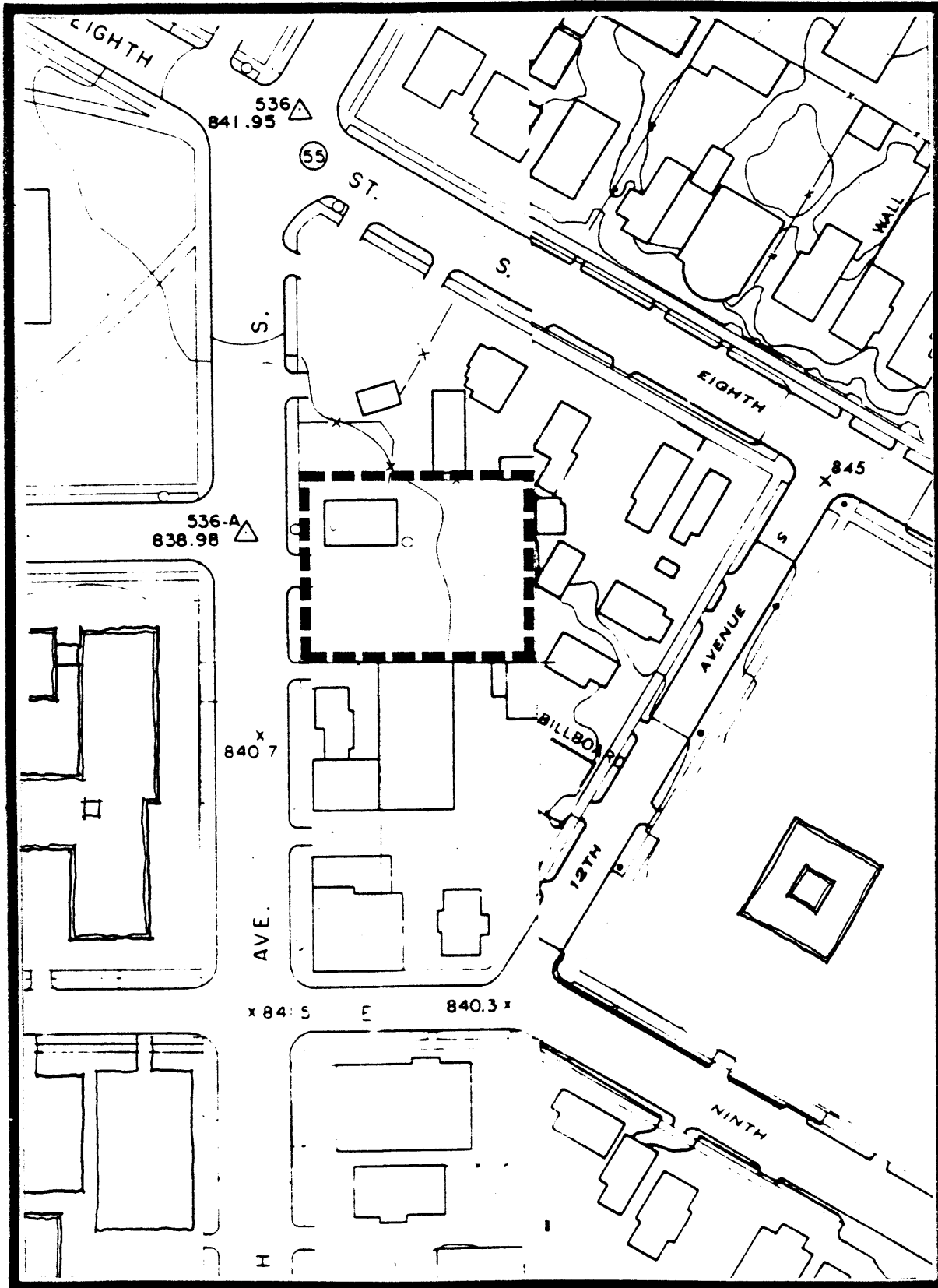

Figure 8-5

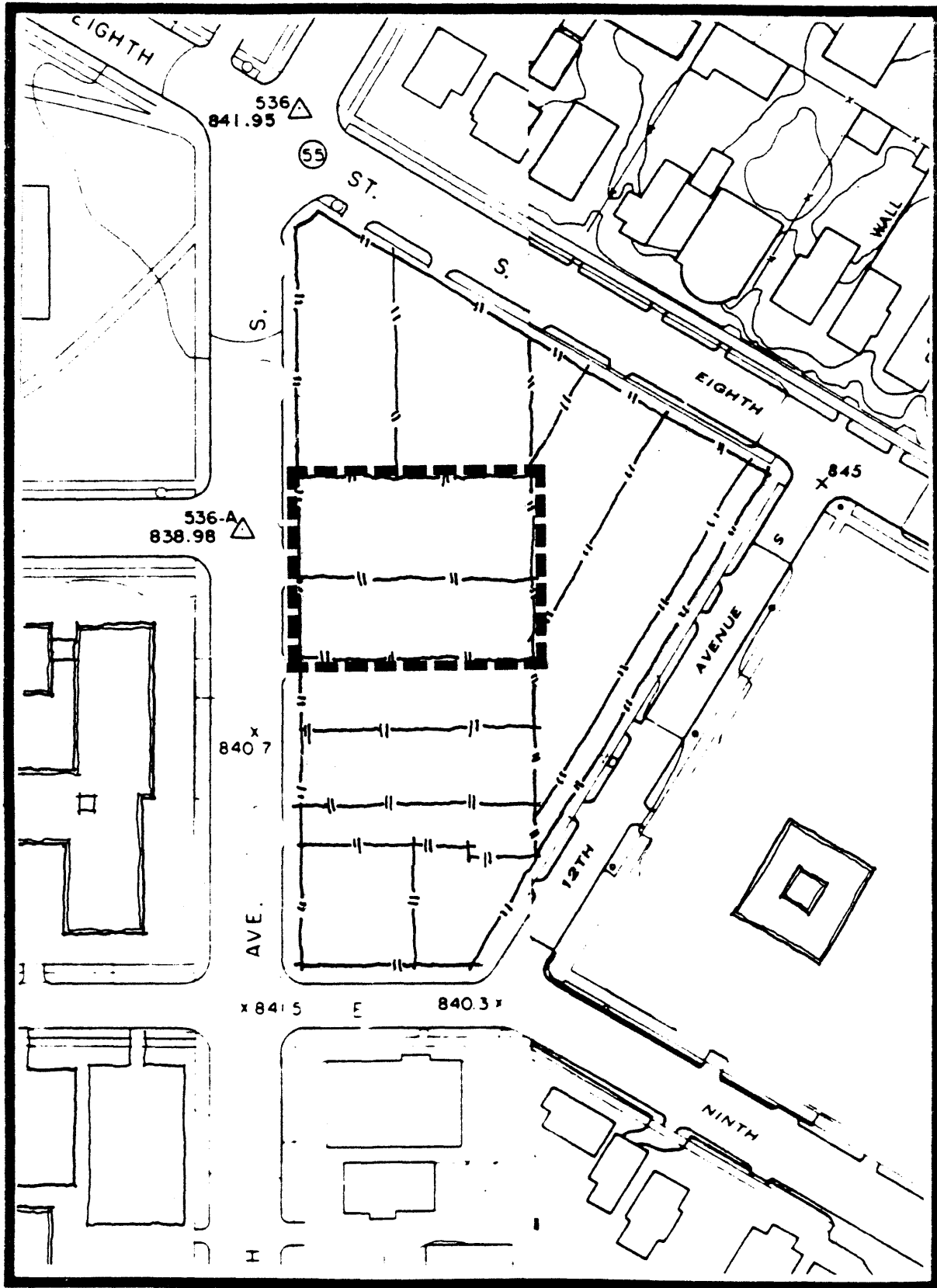

Figure 9-6

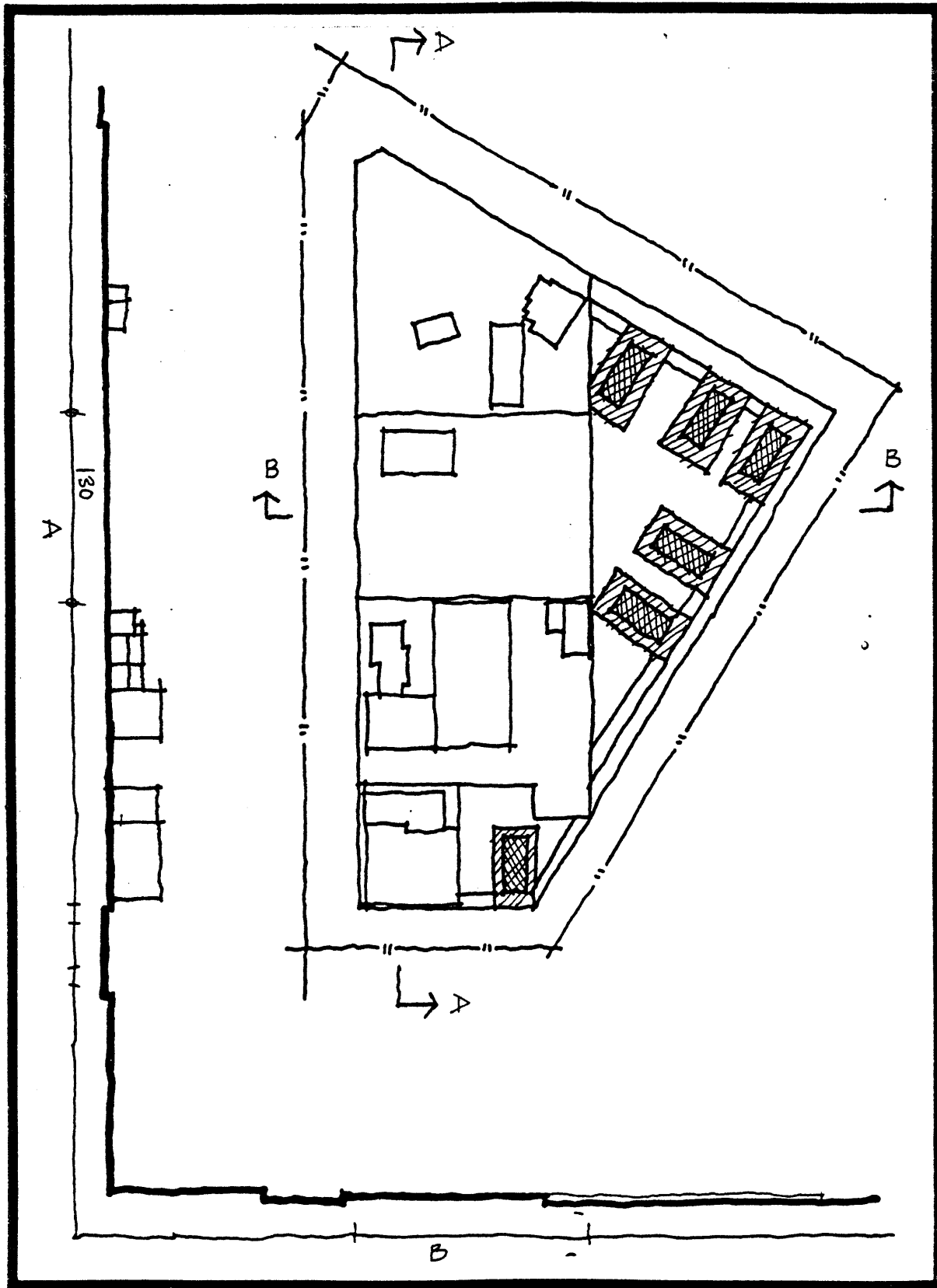

Figure 8-7

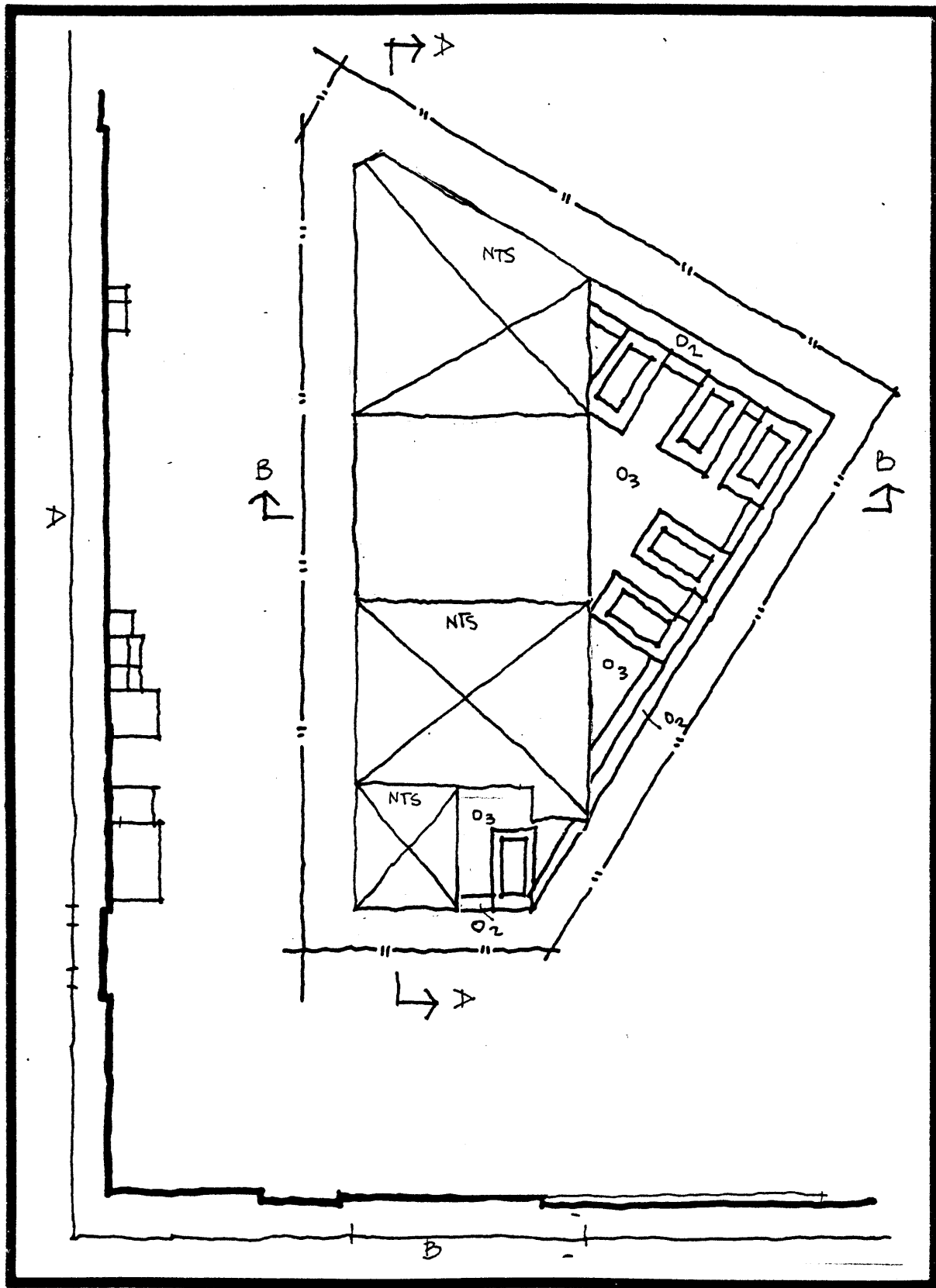

Figure 8-8

Step Three

Prepared by urban designers working with the Elliot Park Neighborhood Incorporated (EPNI) and block residents living in the environs of the site. It includes the development of the three pathway diagrams developed by the above groups through participatory processes:

1. Regulatory diagram Figure 8-9
2. Materials diagram Figure 8-10
3. Pattern diagram (existing) Figure 8-11

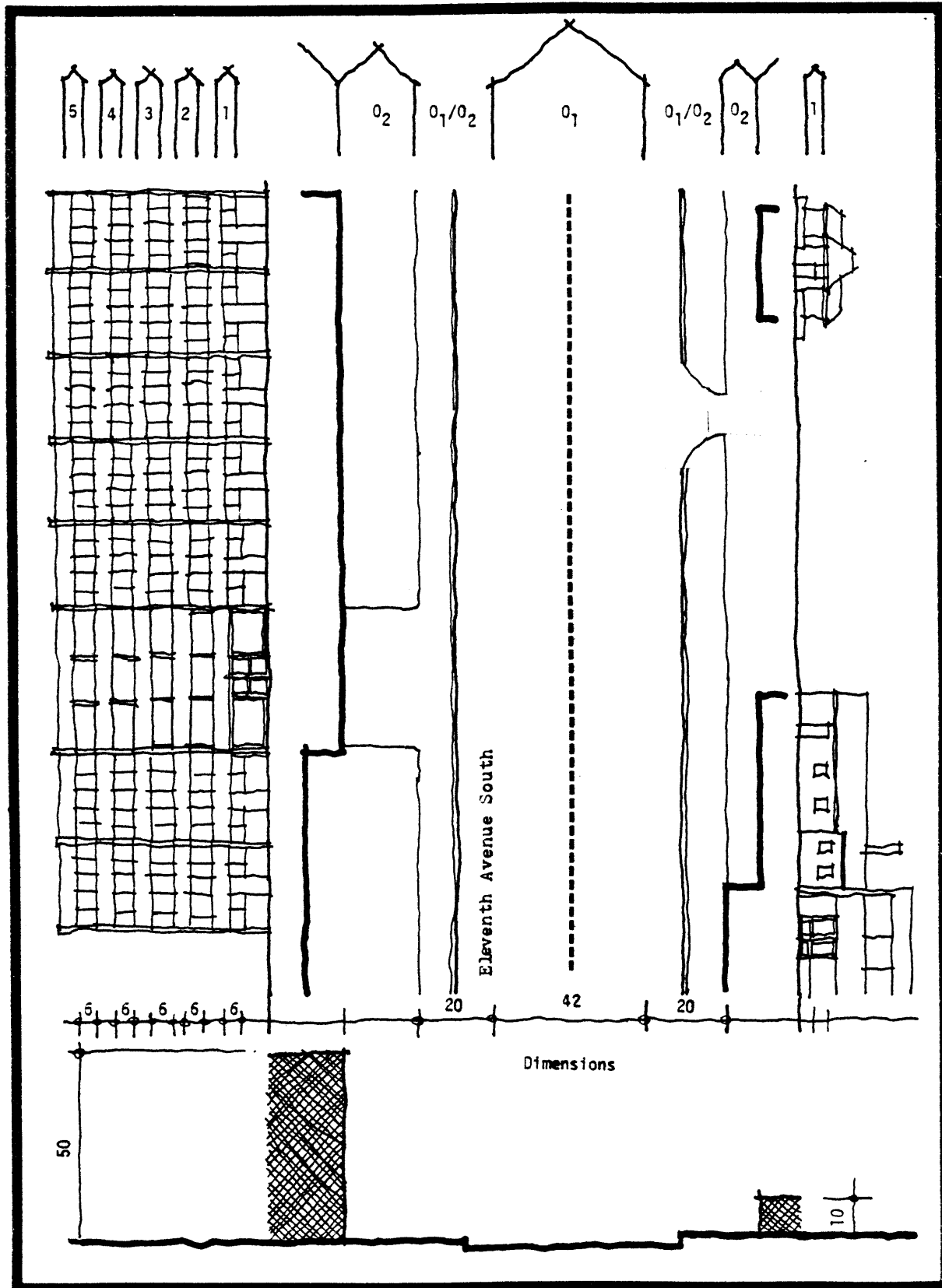

Figure 8-9

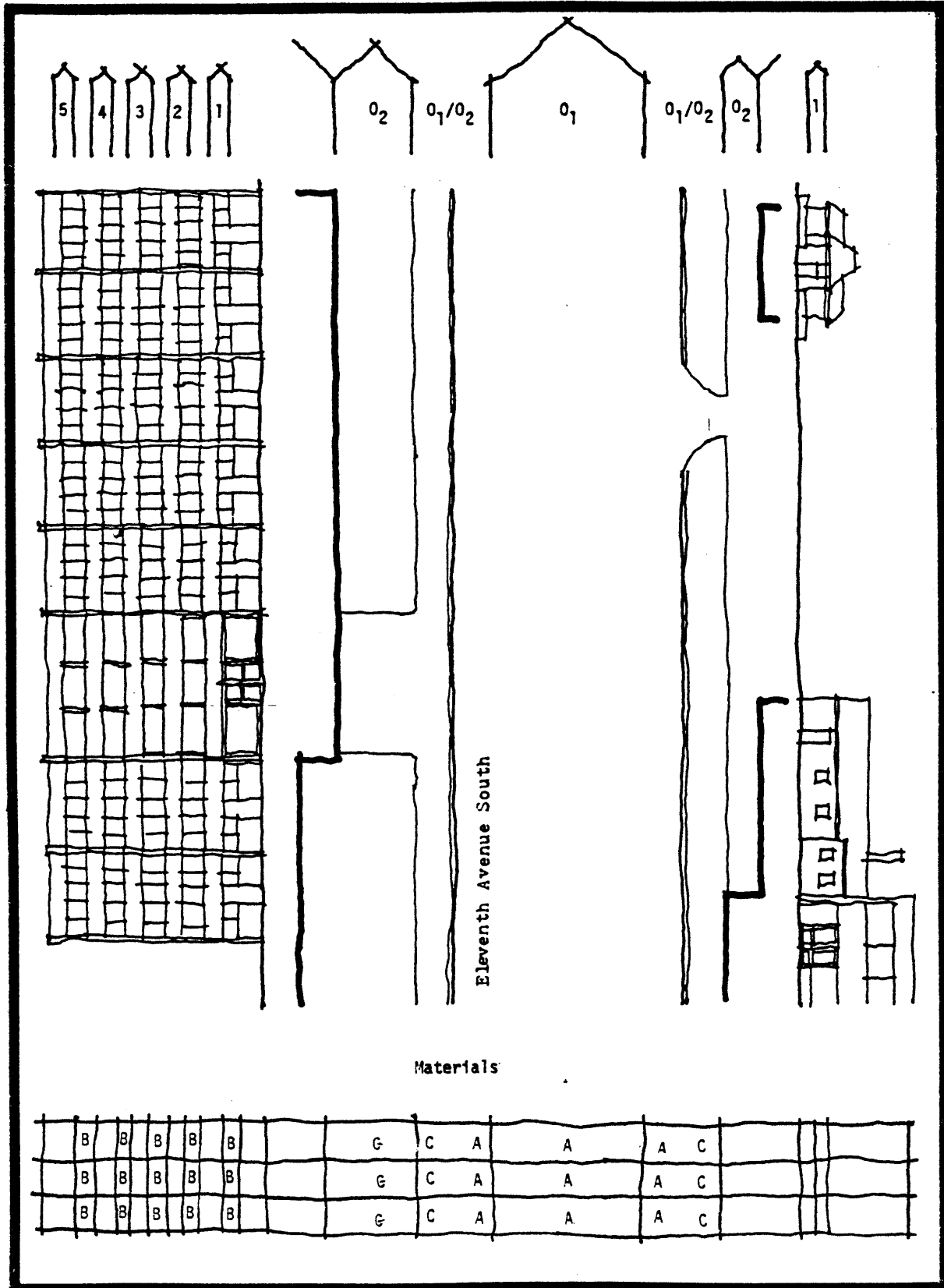

Figure 8-10

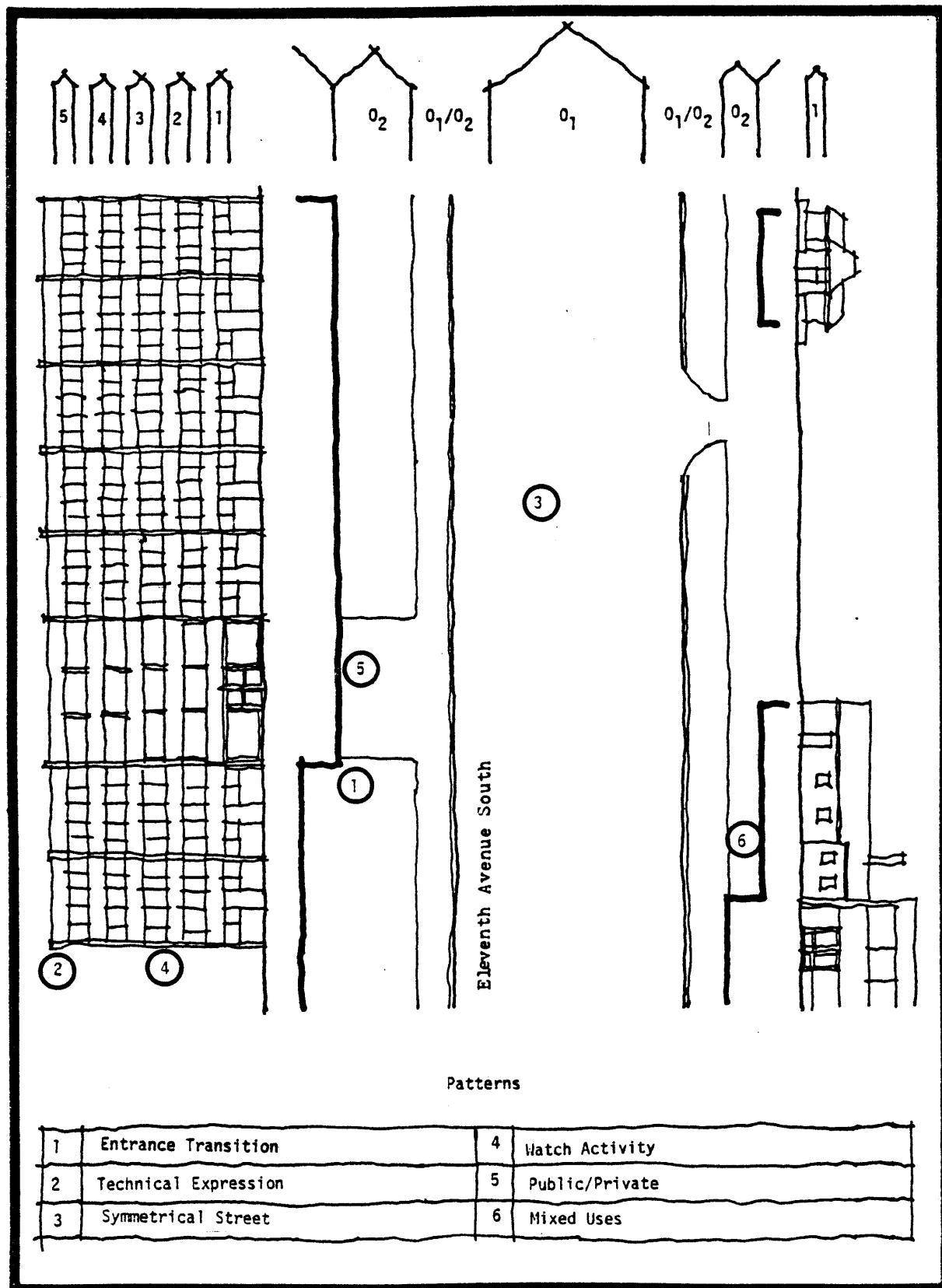

Figure 8-11

Step Four

The parcel/program analysis is prepared by the urban designers working with the Elliot Park Neighborhood Incorporated (EPNI). The analysis includes the following steps:

1. Description of the building program. Figure 8-12
2. Description of the site area. Figure 8-12
3. Identification of zoning requirements. Figure 8-13 8-14
 - a. lot size requirements
 - b. yard requirements
 - c. building bulk limitations (identification of FAR premiums if applicable)
 - d. off-street parking
 - e. off-street loading

Building Program: Appartment with Rental Space

1. 32 Efficiency Apartments Each Appartment Unit 650 SF	20,800 SF
2. Rental Space	2,500 SF
3. Restaurant	2,500 SF
4. Circulation Space 25,800 SF x 10%	2,580 SF

Site Area:

1. 130 FT x 150 SF	19,500 SF
--------------------	-----------

Expected FAR:

$$\frac{25,800 \text{ SF}}{19,500 \text{ SF}} = 1.3 \text{ FAR}$$

Fire Zone :

III

Figure 8-12

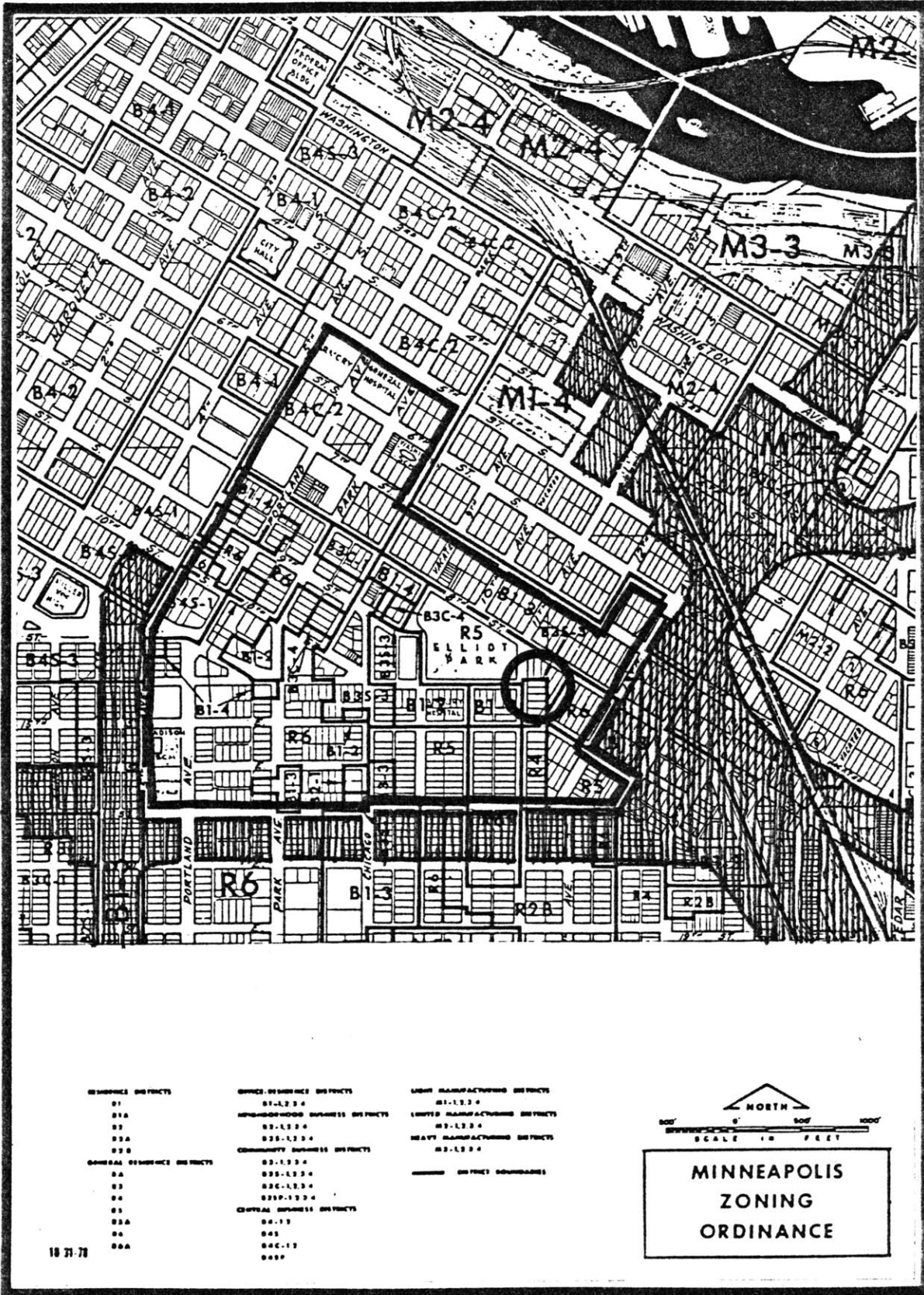

Figure 8-13

Zoning Requirments: B3S - 3

Lot Size Requirements:

1. Minimum Lot Area
600 SF per DU or 32 x 600 SF 19,200 SF

Yard Requirements:

1. Front: 10 FT

2. Side: 5 FT + 2 FT x 5 FT 15 FT

3. Rear: 3 FT + 2 FT x 5 FT 18 FT

4. Open Yard:
10% for Permitted Use.
150 FT x 130 FT x 10% 1,950 SF

FAR: For Permitted Restaurant/Apartment use. 1.7

Off Street Parking:

1. One Car per DU
300 SF x 32 9,600 SF

2. One Car per 100 SF of Public Space
10 Cars x 300 SF 3,000 SF

Off Street Loading: 600 SF

Figure 8-14

Step Five

This step is the review of the previous four steps and identifies the community's position for concept plan review with the City Planning Commission and the developer. These design guidelines are made up of the following information:

1. Parcel identification Figure 8-15
2. B analysis Figure 8-16
3. O analysis Figure 8-17
4. Pathway diagrams Figure 8-18, 8-19, 8-20
5. Massing options consistent with the above Figure 2-21

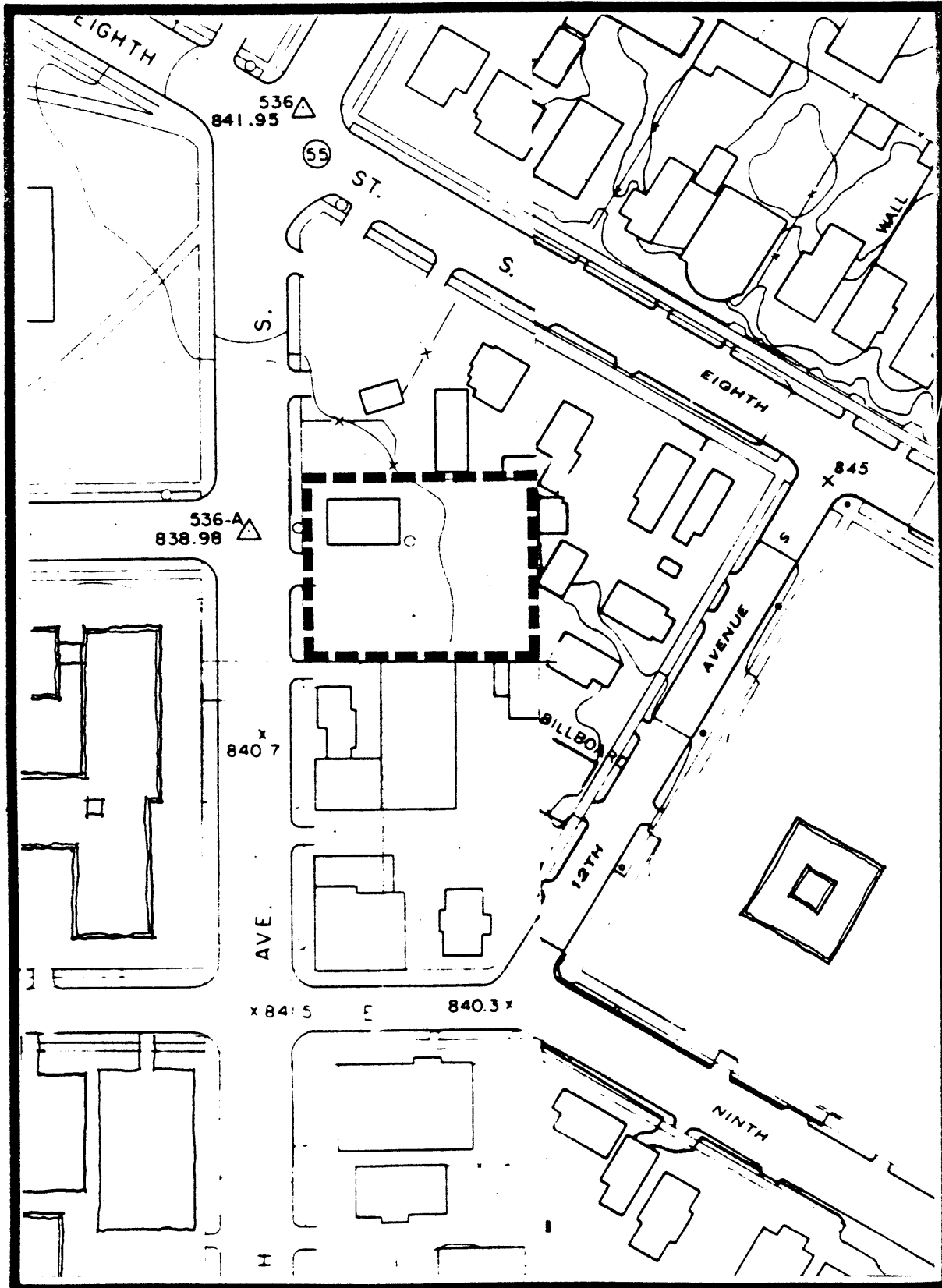

Figure 8-15

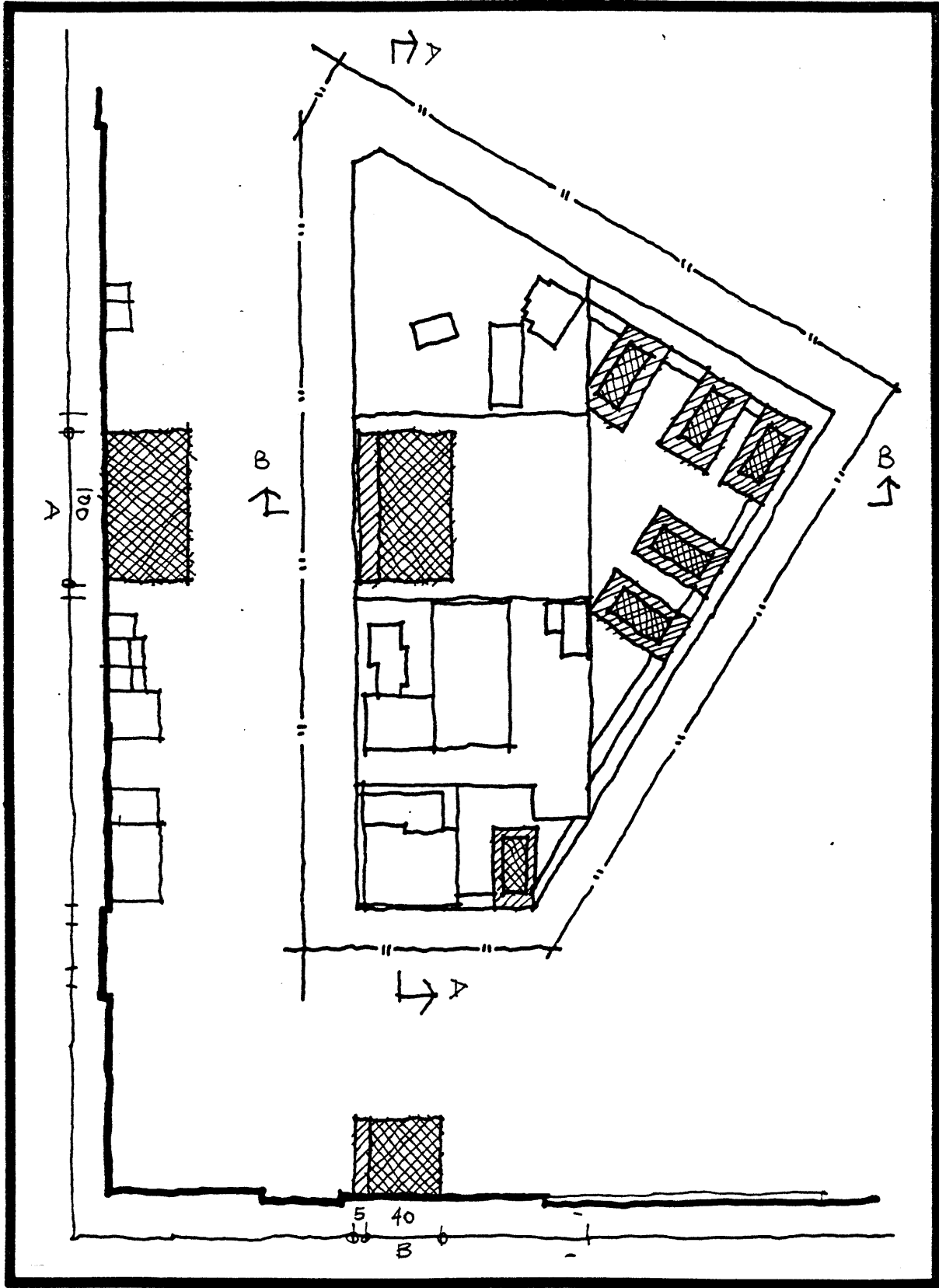

Figure 8-16

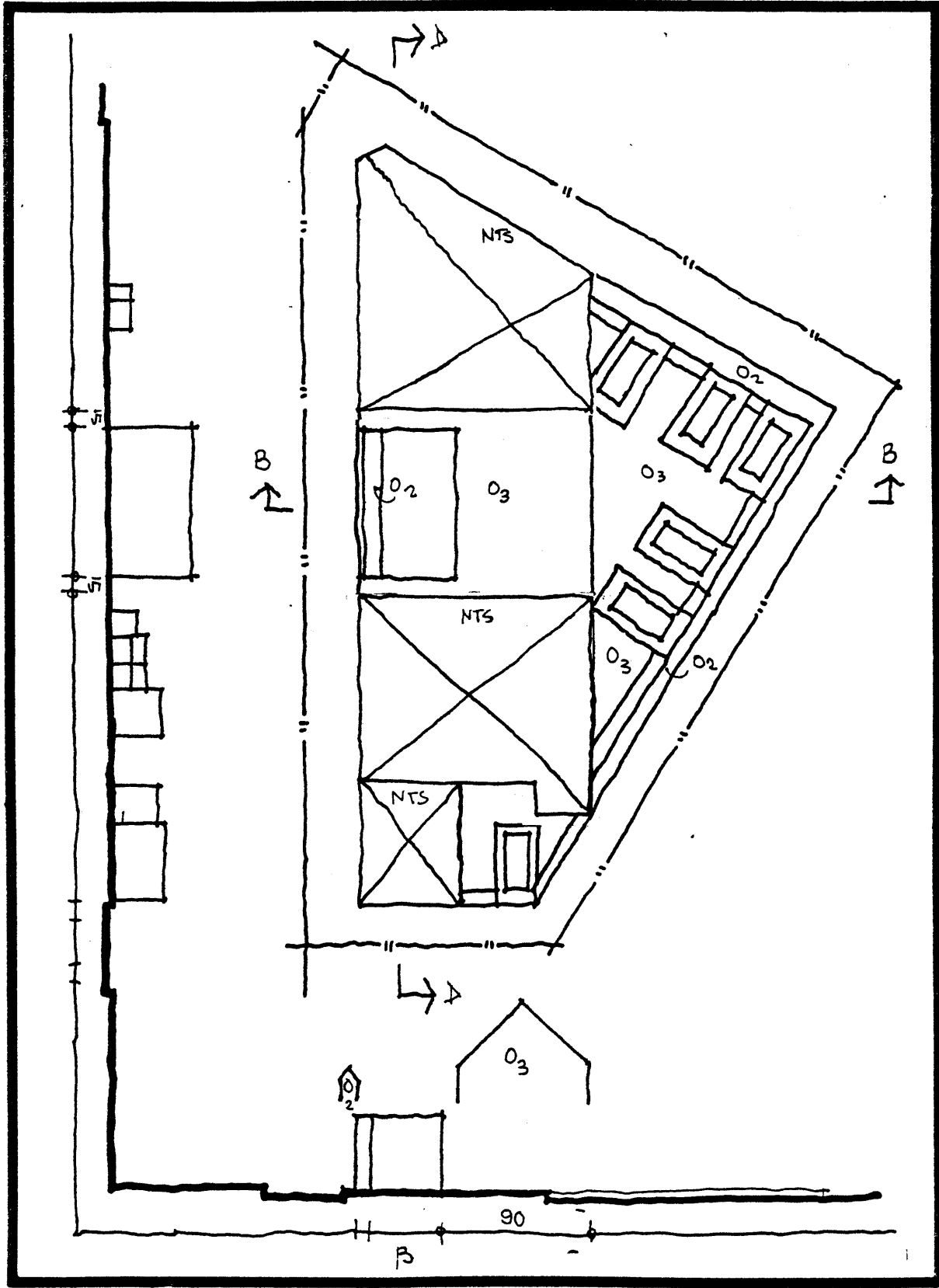

Figure 8-17

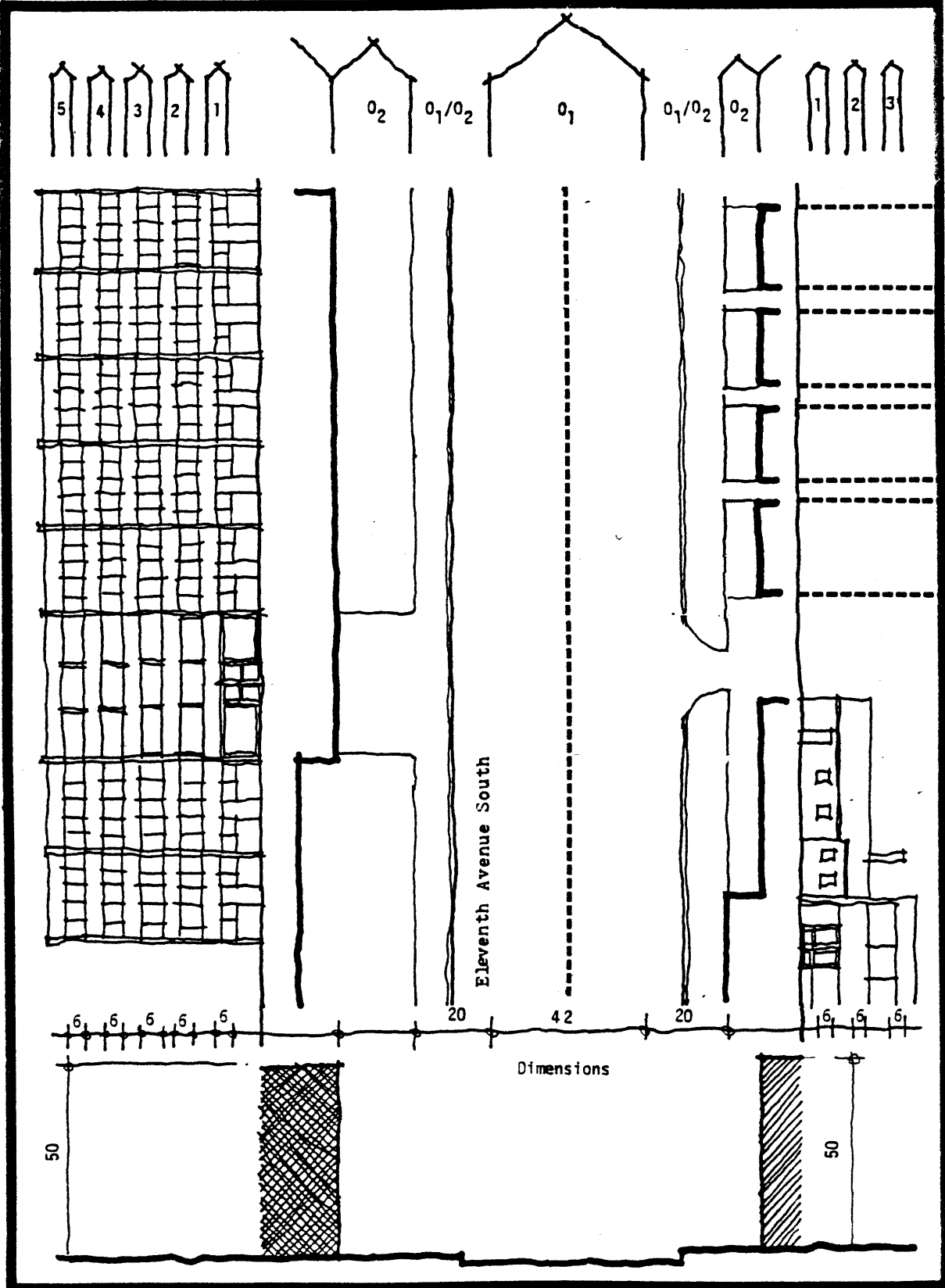

Figure 8-18

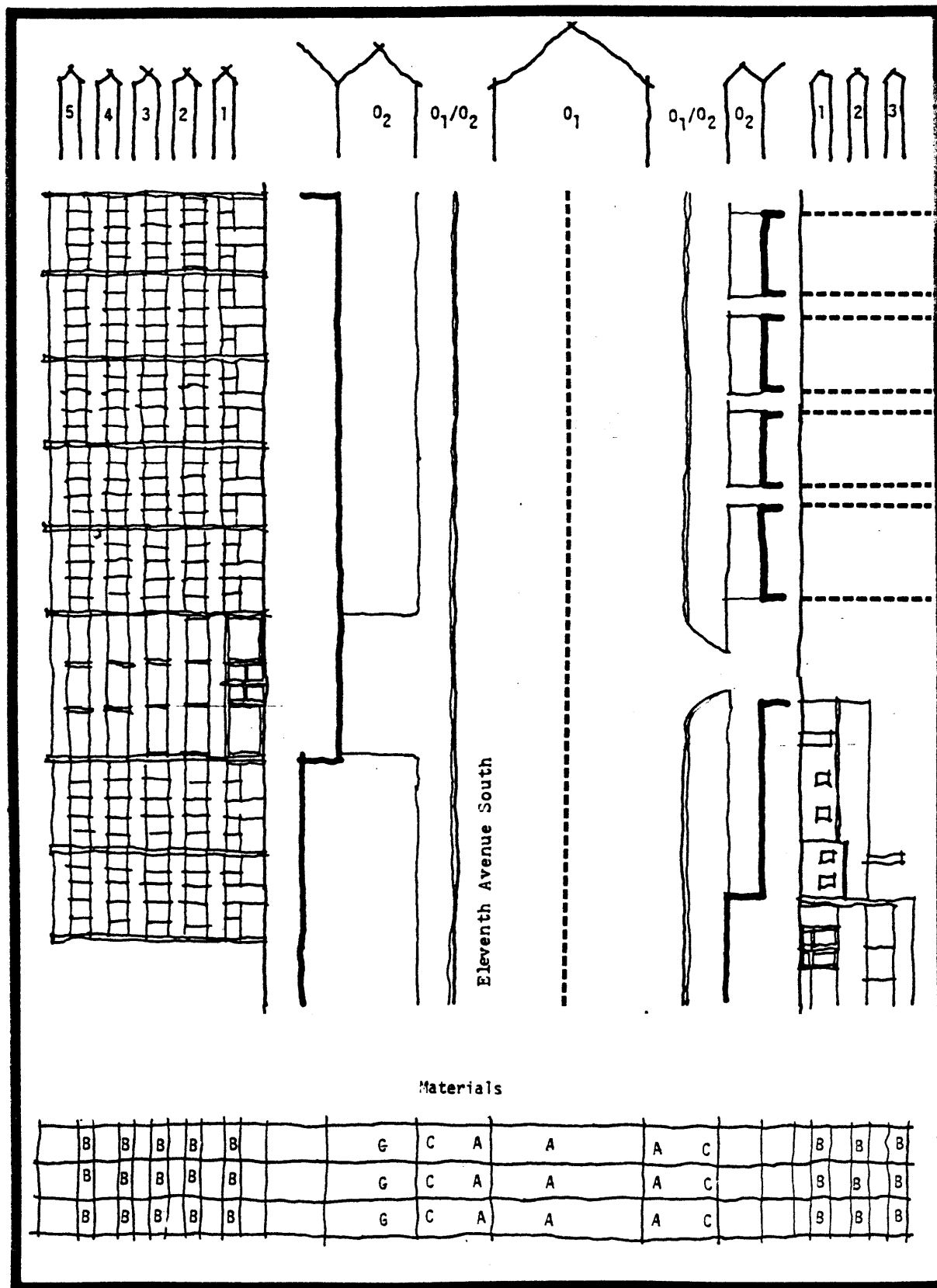

Figure 8-19

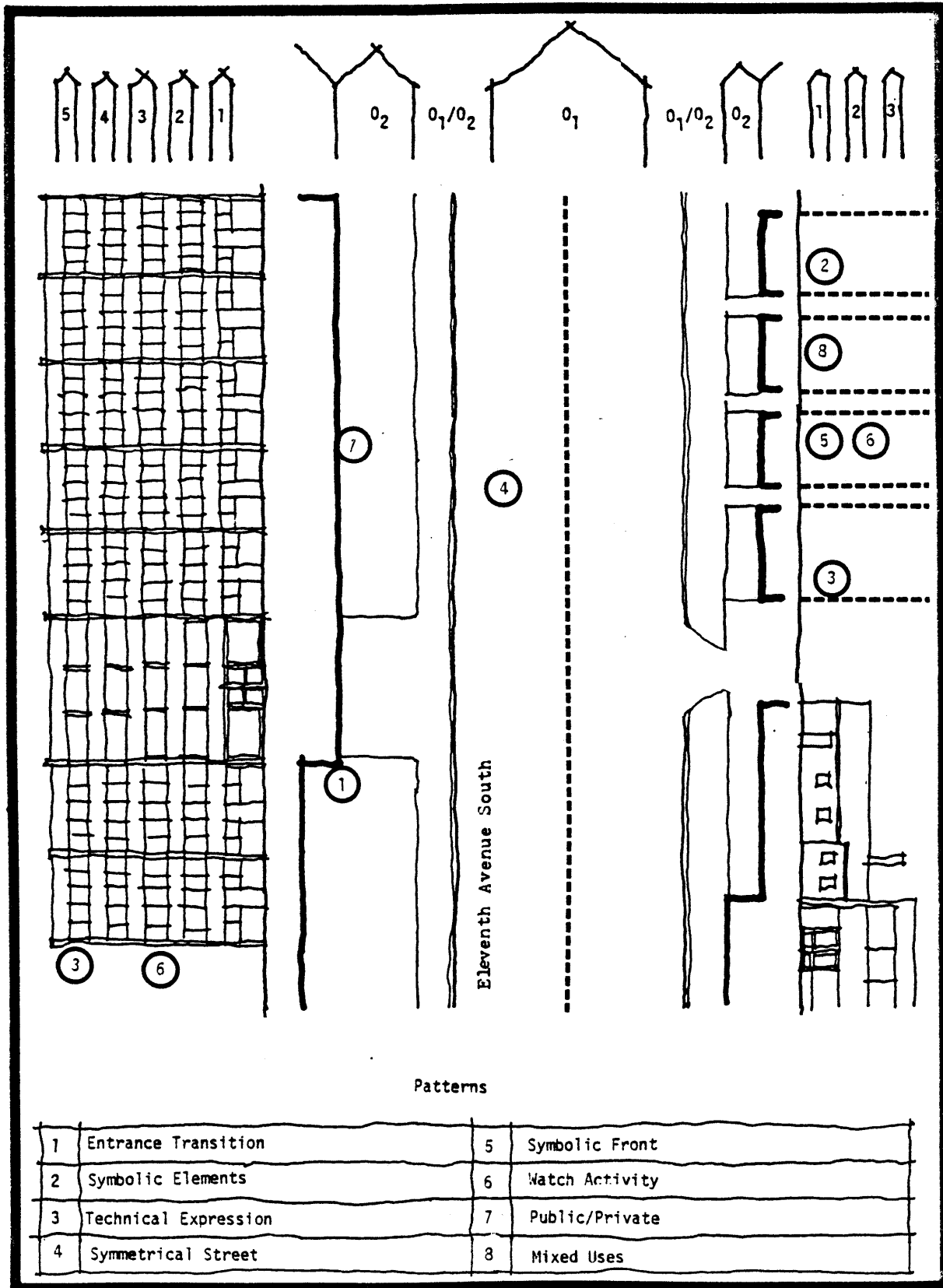

Figure 8-20

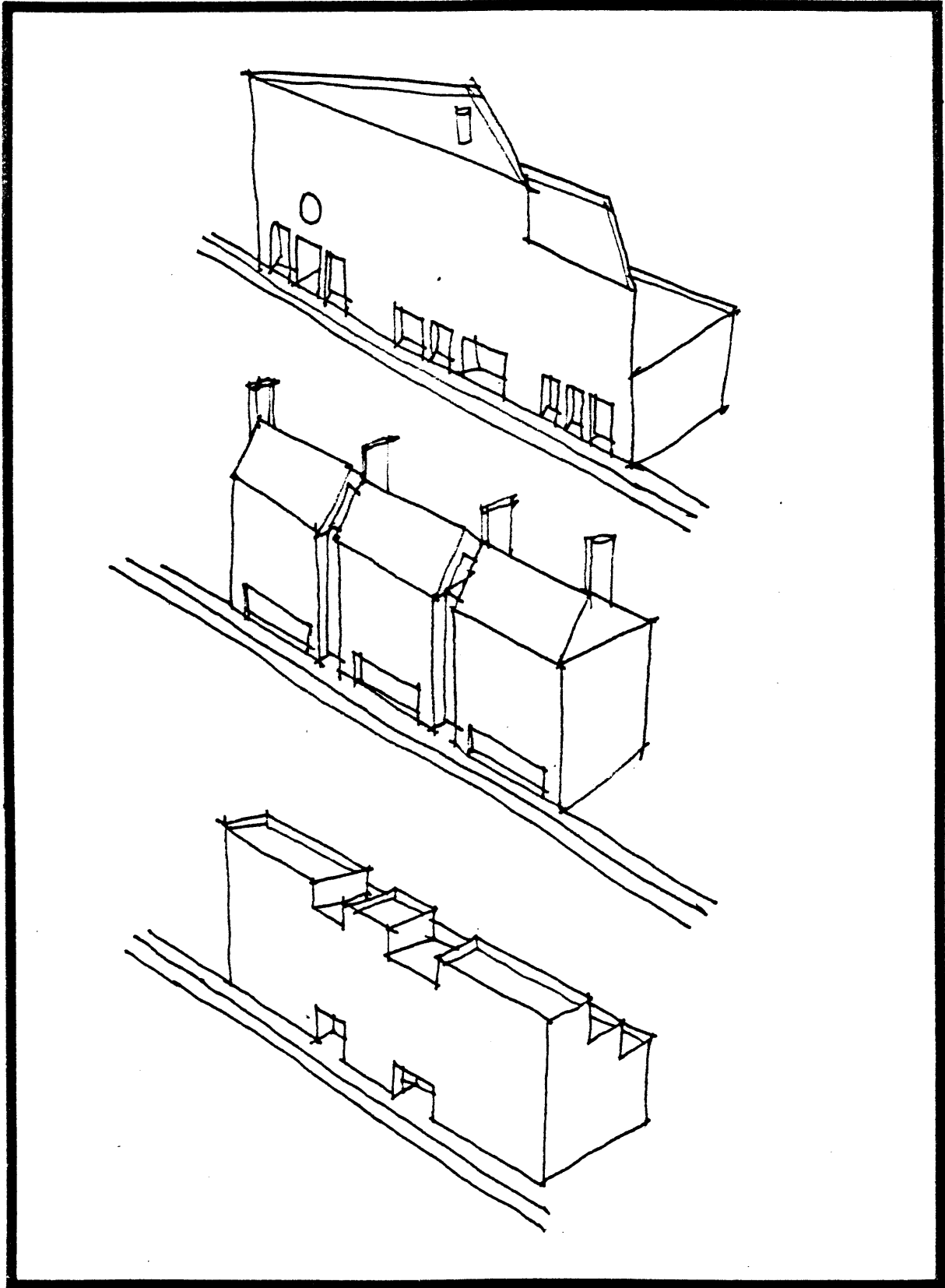

Figure 8-21

Design guidelines in this example were also used for promotion. They represent an effort to describe a building project which meets the ends of both the community and the private land owner.

The FAR requirements of the project are compatible with the existing 1978 zoning law. At the district level block diagram, the building height and setback were regulated. The block diagram showed that the procedure could be used for irregularly shaped parcels and that non-thematic buildings could be regulated just as well as thematic buildings.

The pathway diagrams performed the same function as in the previous examples; here, however, they were used for a non-thematic building.

Overlooking the promotional context of this example, the intervention described a conventional setting, i.e. a dialogue between Level 3, 4, and 5 actors.

Part IV

In Part IV the concluding chapter will summarize the thesis study and briefly evaluate guidelines as a tool for moderating physical development.

Chapter Nine

Summary

The goal of this thesis has been to develop a methodology for design guidelines that would make new development more sensitive to existing context.

By so doing, we would develop design guidelines which would respond to neighborhood needs as well as identify contextual issues important to local residents when confronted with a need to modify the impact of new development.

To do this, we first needed to find a way to identify context and intervention. We did this from two perspectives--the theoretical and the analytical. The theoretical perspective identified the current models in urban city form: the oldest generally described context and the more recent described forms of intervention. The work of two theoreticians helped formulate the analytical perspective. Lynch's Image of the City developed a morphological language, from which the notion of "district" served as a model for describing context. Similarly, the ideas from John Habraken and SAR '73 helped formulate an analytical methodology for describing the notion of district with prescriptive standards.

Since we identified the Block City model as the most common form of urban context, we used our methodology to analyze two residential neighborhoods, one an automobile-oriented district in St. Paul, the other a pedestrian-oriented district in Boston. With each district we examined the levels and actors involved in maintaining district quality.

We found that the analytical technique could be applied in either setting and that it could also be used for comparative analysis of one district environment with another. To understand how interventions impact on existing Block City environments, we examined five case studies which showed how, in different settings, contextual qualities were either maintained or ignored. In each case, actors at different levels were involved, generating different design responses at each level. We found that the interventions most sensitive to existing context came with the involvement of Level 3 and 4 actors. Without them, interventions were indifferent to context.

From this intervention study, we developed our method for constructing design guidelines, which was based on our analytical methods. We then examined a typical urban city setting and an urban neighborhood within that setting. The method was applied in three development scenarios, with different uses in mind. The studies showed that the method could be used by community advocates as well as by urban designers working for the city on behalf of the community.

Basic to the method are concepts derived from SAR '73. The most fundamental idea is the notion of levels in land-use decision making in an urban context. The highest is Level 2, the city legislative bodies, and the lowest is Level 5, the individual property owner acting alone or through an architect. Because the most common dialogue in land-use activity exists between Level 2 and Level 5, there are generally sufficient documentation techniques to assist with decisions made only at these levels. Consequently, the method was

based on the need to provide a method of documentation for issues found on Levels 3 and 4.

Basic to the method were several important concepts. First, it is possible to think of environment wholistically as a system of built and open spaces. Countrysides are environments of open space with little built space; on the other hand, cities are often environments of built space with little open space.

In city contexts, built spaces and open spaces that were often repetitive were considered thematic, which contrasts with those areas which were considered non-thematic. In residential areas, non-thematic built and open space often were used for commercial or institutional uses.

To help us identify the boundaries between "built space" zones and "open space" zones, we used the term "margin" to indicate the areas where these two zones overlapped. This structure allowed us to diagram and dimension existing Block City environments both in plan and elevation. From these diagrams we could look at district Level 3 issues with block diagrams and neighborhood Level 4 issues using pathway diagrams.

We can summarize our method by turning to the level diagram 4-3, which suggests that at every level there is an area of territorial responsibility with issues of concern unique to that territorial level. Higher levels tend to be more abstract, while lower levels are more concrete and specific. Similarly, decisions on higher levels control actions on lower levels, while decisions at lower levels influence only decisions at higher levels.

Since there is a hierarchy of territorial concern, there is a hierarchy of documentation, which identifies and describes issues at that particular level of concern; this hierarchy was outlined in Chapter 4.

The mission of the thesis was to provide design guidelines for Levels 3 and 4 which would help identify contextual issues surrounding the parcel activity of the architect at Level 5 (see Figure 4-7).

Level 3, district design guidelines, used block diagrams of built and open space to document the pre-intervention context and the recommended constraints to place on the anticipated intervention.

Level 4, neighborhood design guidelines, used the pathway guideline to document the pre-intervention context and the recommended constraints on the anticipated intervention.

Given this information, the architect could proceed with his customary site and building plan drawings as seen in Figure 4-14.

The structure for gathering this district and neighborhood issue information was not discussed, since clearly the setting required to obtain it could be provided by neighborhood community advocates or the city's urban design staff.

We applied the method in Elliot Park, an inner-city community with a weak sense of district, which was facing intense development pressure. The first study showed how the guidelines could be employed to ameliorate the impact of undesired high density institutional housing. This scenario showed the most conventional application of the guidelines: to prevent or alter the development of undesired building structure.

The second and third studies showed a promotional use of the design guidelines, which were employed to promote a pedestrian greenway from Elliot Park to the city's central pedestrian mall to encourage new construction in a form compatible with adjacent structures, and finally to draw attention to the need to preserve historical structures in the second scenario. The workability of the method in this case is problematic. There might be other ways to achieve the same ends. It would work only if Level 2 urban designers agreed with the goals to be achieved.

The promotional application in the third case study seemed more possible. Here the relationship was between Levels 3, 4, and 5. The solution would benefit all parties and would not require an extensive Level 2 administrative apparatus. Given this information, the architect could proceed with his customary site and building plan diagrams as seen in Figure 4-14.

In briefly assessing the approach offered by this method, we assume that the goals of contextual continuity, as seen in Figures 9-1 and 9-2 are valued by the city, district, and neighborhood actors.

Given that goal, the guidelines seem workable for the following reasons:

1. They provide a way to decentralize land-use decision making through the exercise of hierarchical decision making based on the level diagram.
2. They provide a wholistic, systematic basis for analyzing urban environments in terms of built and open space.



Figure 9-1

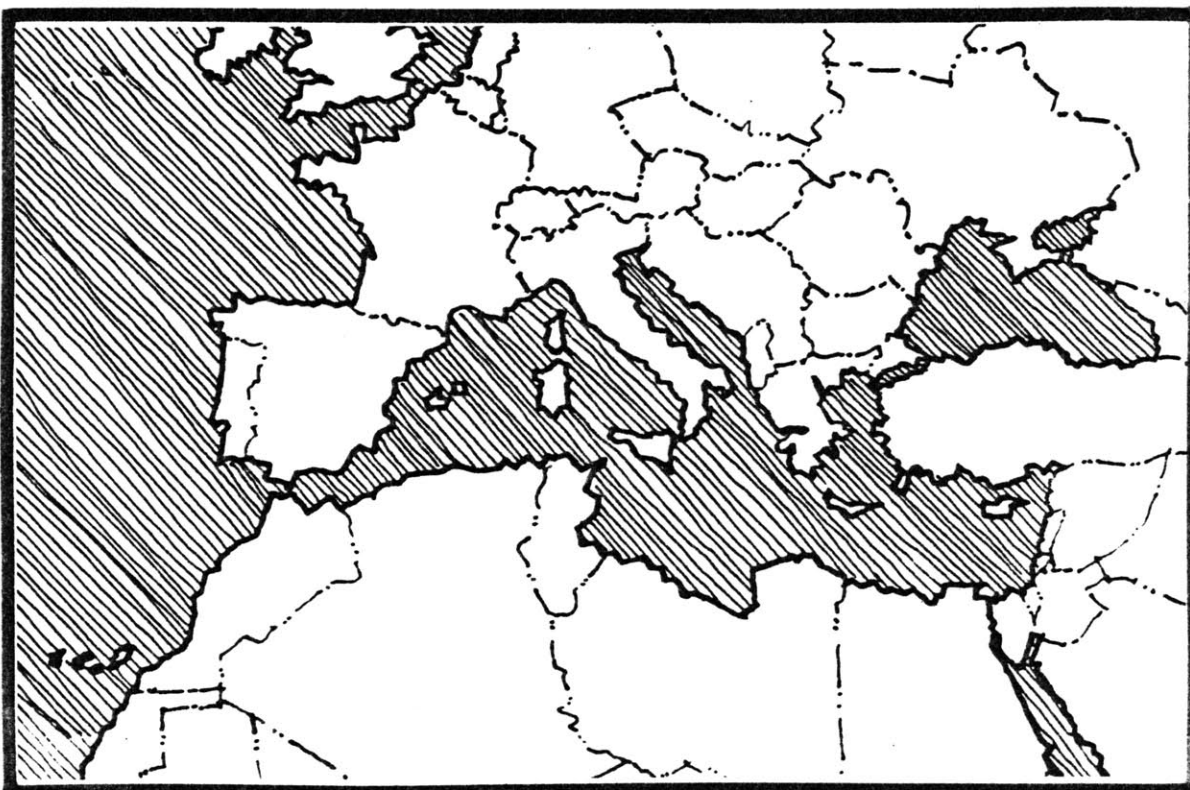

Figure 9-2

3. They provide a common language whereby laypeople and professionals can discuss environmental conflicts and issues.

On the other hand, there are aspects that make a guideline approach to environmental control unworkable:

1. They are based on a theory of urban form that is presently not accepted by most practicing architects presently given to Radiant City and Super Block City models for development.
2. They confront the existing patterns of Level 2 to Level 5 land-use planning activities. Challenging this centralized relationship for a more decentralized land-use administration would require surmounting numerous political obstacles. Probably Level 3 and 4 involvement would naturally only occur easily in politically powerful residential areas.
3. They need refinement, which requires that they be applied in a recognized setting with at least a marginal acceptance by Level 2 actors. Because of the resistance indicated in points 1 and 2, this opportunity may not be forthcoming.

Since the author feels that the potential environmental quality achieved by more decentralized land-use planning via design guidelines is important, the above disadvantages clearly should be confronted and overcome.

Footnotes

1. Sir Leslie Martin, "Land Use and Built Forms," Cambridge Research, April, 1966, pp. 8-14.
2. Camilla Sitte, City Planning According to Artistic Principles, Random House, 1965.
3. Jane Jacobs, The Death and Life of Great American Cities, Vintage Books, 1961.
4. Leon Krier, ed. "Urban Transformations," Architectural Design, April, 1978, pp. 219-266.
5. Robert Fishman, Urban Utopias in the Twentieth Century, Basic Books, p. 27.
6. Ibid, p. 178.
7. Ibid, p. 203.
8. Kevin Lynch, The Image of the City, MIT Press, 1960.
9. SAR '73, The Methodical Formulation of Agreements Concerning the Direct Dwelling Environment, Stichting Architectural Research, 1973.
10. "Conserving Europe's 2,000-year Heritage - Some Hints for an Infant American," Nation's Cities, April, 1978, p. 17.

Chapter Three

1. Kent C. Bloomer and Charles Moore, Body, Memory, and Architecture, Yale University Press, p. 132.
2. Oscar Newman, Design Guidelines for Creating Defensible Space, United States Department of Justice, 1976, p. 6.
3. N. J. Habraken, Course notes from "Design and the Everyday Environment," September, 1979.
4. Kenneth Dayton, Minneapolis Tribune, March 28, 1972.
5. Loring Park Community Crier, January, 1977.
6. Ibid.

Chapter Five

1. An Improvement Plan for Elliot Park Neighborhood. Minneapolis, 1977.

Bibliography

- Alcaly, Roger E. and David Mermelstein, eds. The Fiscal Crisis of American Cities. New York: Vintage Books, 1977.
- Allman, Ted. "The Urban Crisis Leaves Town." Harper's, December, 1978, pp. 41-52.
- Alexander, Christopher, et. al. A Pattern Language. New York: Oxford University Press, 1977.
- _____. The Oregon Experiment. New York: Oxford University Press, 1975.
- Application for Redevelopment Project and Supporting Documents. Elliot Park Redevelopment Area, May 19, 1978.
- Back Bay Architectural District Business Sector Guidelines. Prepared for Back Bay Architectural Commission, 1977.
- Back Bay Development Plan. Prepared for the Back Bay Development Council, 1967.
- Back Bay Residential District Guidelines for Exterior Rehabilitation and Restoration. Prepared by Back Bay Architectural Commission.
- Bacon, Edmund N. Design of Cities. Rev. ed. New York: Penguin Books, 1976.
- Barnett, Jonathan. Urban Design as Public Policy. New York: Architectural Record, 1974.
- Besser, James David. "Gentrifying the Ghetto." The Progressive. 30 January, 1979. pp. 30-33.
- Bloomer, Kent C. and Charles We. Moore. Body, Memory, and Architecture. New Haven: Yale University Press, 1977.
- Bluhm, Robert. Jackson Square: A Land Development Strategy. Prepared for the Jamaica Plain Neighborhood Development Corporation, 1978.
- Boston, Tent City Site. Prepared by the Total Studio, School of Architecture and Planning, MIT, 1978.
- Building the Future from our Past. A Report on the Saint Paul Historic Hill District Planning Program. Saint Paul: Old Town Restorations, Inc., 1975.
- Cavanaugh, Gerald. "The Shrinking Middle Class." The Progressive. 34 January 1979, pp. 33-35.

- Central Riverfront Development. Prepared for Minneapolis Riverfront Development Coordination Board, 1977.
- Change Without Loss: Residential Development and Preservation for San Francisco Neighborhoods. Prepared for San Francisco Department of City Planning, 1978.
- City Center '75: A Development District Proposal. Prepared for the City of Minneapolis, 1975.
- Clay, Phillip L. Neighborhood Revitalization: Issues, Trends and Strategies. Prepared for the National Endowment for the Arts, MIT, 1978.
- Conrads, Ulrich. Programs and Manifestoes on 20th Century Architecture. Cambridge, Mass: MIT Press, 1970.
- A Design for Residential Areas. Prepared for the City Council of Essex, England, 1973.
- Elliot Park Housing Policy Plan Report. Prepared by Team 70 Architects, Inc. for Elliot Park Neighborhood, Inc., Minneapolis, Minnesota, 1978.
- Ferebee, Ann, ed. 37 Design and Environment Projects. Washington, D.C.: R.C. Publications, 1976.
- Fishman, Robert. Urban Utopias in the Twentieth Century. New York: Basic Books, 1977.
- Gallion, Arthur B. and Simon Eisner. The Urban Pattern. New York: D. Van Nostrand Company, 1975.
- "Geestenberg--Investigation Study Using SAR '73." 3 Open House, (1978), 49-57.
- Gendler, Neal. "New Made to Look Old, and Old New, as Historic Neighborhood Revived." Minneapolis Tribune. 30 July 1978, Part 9F, p. 1.
- Goetze, Rolf, et al. Stabilizing Neighborhoods: A Fresh Approach to Housing Dynamics and Perceptions. Cambridge, Mass: Public Systems Evaluation, Inc., 1977.
- Goldfield, David R. "Historic Planning and Redevelopment in Minneapolis." AIP Journal. January, 1976, pp. 76-86.
- Griffin, C. W. Development Building: The Team Approach. New York: Halsted Press Division, John Wiley and Sons, Inc., 1972.

- Habraken, N. J. "The Built Environment and the Limits of Professional Practice," unpublished essay.
- Habraken, N. J. et al. Variations: The Systematic Design of Supports. Cambridge, Mass: MIT Laboratory of Architecture and Planning, 1976.
- Hack, Gary. Environmental Programming: Creating Responsive Settings. MIT Thesis. Department of Urban Studies and Planning, 1976.
- Halpern, Kenneth. Downtown USA: Urban Design. New York: Whitney Library of Design, 1978.
- Herr, Philip, et al. Evaluating Development Impacts. Environmental Impact Assessment Project, MIT, 1978.
- Housing Quality: A Program for Zoning Reform. Prepared for the Urban Design Council of the City of New York.
- An Improvement Plan for Elliot Park Neighborhood. Prepared for the Citizens of Elliot Park Neighborhood, Minneapolis, 1977.
- Improvement Plan for Residence. Proposal for Adoption by the City Planning Commission. Prepared by the San Francisco Department of City Planning, 1971.
- Isberg, Gunnar C. Local and Regional Planning in Minnesota. St. Paul: League of Minnesota Municipalities, 1975.
- Jacobs, Jane. The Death and Life of Great American Cities. New York: Vintage Books, 1961.
- Jencks, Charles. The Language of Post-Modern Architecture. New York: Rizzoli International Publications, 1977.
- Krier, Leon, ed. "Urban Transformations." Architectural Design. April, 1978, pp. 219-266.
- Krier, Rob. Stadtraum in Theorie and Praxis. Stuttgart: Karl Kramer Verlag, 1975.
- Kriken, John L. and Irene Perlis Torrey, "Developing Urban Design Mechanisms." ASPO Planning Advisory Service, November, 1975.
- Kostouros, John. "Downtown Developers Seek City Aid." Minneapolis Tribune. 21 October 1978, Part 1S, p. 1.
- _____. "The Middle Class Returns--But Is That Good?" Minneapolis Tribune. 24 June 1978, Part 1S, p. 1.

- Landman, Wendy Anne. Environmental Impact Assessment and the Quality of Local Design. MIT Thesis, Department of Urban Studies and Planning, 1978.
- Lanegran, David A. "Neighborhood Conservation in the Twin Cities," Architecture Minnesota. July-August, 1978, pp. 14-20.
- Le Corbusier. The Four Routes. London: Dennis Dobson Ltd., 1974.
- Lischewski, Hans-Christian. An Application of the SAR Tissue Method with a View to the Alamo Square Area. MIT Thesis, Department of Architecture, 1978.
- Loring Park Development. Prepared for the Office of the City Coordinator, Minneapolis.
- Loring Park Development Progress Report. Prepared for the Office of the City Coordinator, Minneapolis, 1975.
- Loring Park Housing Interim Report. Prepared for Minneapolis Planning and Development Commission, 1972.
- Lynch, Kevn. The Image of the City. Cambridge, Mass: MIT Press, 1960.
- _____. Managing the Sense of a Region. Cambridge, Mass: MIT Press, 1976.
- _____. "Quality in City Design." Who Designs America. Ed. Laurence B. Holland. Garden City, N.Y.: Anchor Books, 1975.
- _____. Visual Analysis: Community Renewal Program, Brookline, Massachusetts. Prepared for the Brookline Board of Selectmen, 1965.
- _____. What Time is This Place? Cambridge, Mass: MIT Press, 1972.
- MacFayden, Dugald. Sir Ebenezer Howard and the Town Planning Movement. Manchester, England: Manchester University Press, 1970.
- Martin, Sir Leslie. "Land Use and Built Forms." Cambridge Research, April, 1966, pp. 8-14.
- McCaffrey, Robin H. and Janet Needham-McCaffrey. Old as the Hills, MIT Thesis, Department of Urban Studies and Planning, 1978.
- McNulty, Robert and Gordon Binder. "Conserving Europe's 2,000-Year Heritage--Some Hints for an Infant America." Nation's Cities, April, 1976, pp. 17-24.

- McNulty, Robert and Stephen A. Kliment. Neighborhood Conservation. New York: Whitney Library of Design, 1976.
- Metro Center '85. Study for Development of Program and Priorities for Expanded Job and Investment Opportunities in Central Minneapolis. Prepared for the Minneapolis Planning and Development Commission, 1970.
- Mississippi/Minneapolis--A Plan and Program for Riverfront Development. Prepared for the City of Minneapolis Planning Commission, 1972.
- Morehouse, Ward. "New Gentry Drama on Urban Stage." Christian Science Monitor. 7 February 1979, p. 6.
- The Mund Plan. Prepared for the Department of Planning, Cornell University.
- Myers, Barton. "Vacant Lottery." Design Quarterly, 108 (Fall, 1978), 1-50.
- Nally, Thomas John. Design Review. MIT Thesis. Department of Urban Studies and Planning, 1977.
- Newman, Oscar. Design Guidelines for Creating Defensible Space. Prepared for Law Enforcement Assistance Administration, Washington, D.C. 1976.
- Osgood, Viola. "Cambridge Hopes for Renewal without Uprooting Residents." Boston Globe, December, 1978, p. 15.
- A Qualitative Checklist for Compact Housing. Ottawa: Canadian Housing Design.
- Pattison, Timothy James. The Process of Neighborhood Upgrading and Gentrification. MIT Thesis, Department of Urban Studies and Planning, 1977.
- Rapoport, Amos. House Form and Culture. Englewood Cliffs, N.J.: Prentice-Hall, 1969.
- _____. Human Aspects of Urban Form. New York: Pergamon Press, 1977.
- Roberts, Margaret. An Introduction to Town Planning Techniques. London: Hutchinson of London, 1974.
- Robinson, Sharon Desnise. An Urban Design and Development Plan. MIT Thesis, Department of Urban Studies and Planning, 1978.
- SAR '73, The Methodical Formulation of Agreements Concerning the Direct Dwelling Environment. Eindhoven, Holland: Stichting Architecten Research, 1973.

- Schurmann, Franz, and Sandy Close. "The Emergence of Global City USA." The Progressive. 28 January 1979, pp. 26-29.
- Seldin, Maury and Richard H. Swesnik. Real Estate Investment Strategy. New York: Wiley-Interscience, 1970.
- Shaw, Cathy. "Will Suburbia Get Too Old?" Boston Globe. 24 October 1978, p. 3.
- Sitte, Camillo. City Planning According to Artistic Principles. New York: Random House, 1965.
- Stichting Architecten Research. Deciding on Density. Eindhoven, Holland: Stichting Architecten Research, 1977.
- Tab, William K. and Larry Sawers, eds. Marxism and the Metropolis. New York: Oxford University Press, 1978.
- Tuan, Yi-Fu. Topophilia. Englewood Cliffs, N.J.: Prentice-Hall, Inc., 1974.
- Urban Design Mechanism for San Antonio. Prepared for the City of San Antonio City Planning Department, Community Renewal Program, 1972.
- The Urban Design Plan for the Comprehensive Plan of San Francisco. Prepared by the Department of City Planning, San Francisco, 1971.
- Visual Form of Dallas. Prepared for the City of Dallas Department of Urban Planning, 1977.
- Whittier East Design Study. Prepared for the City of Minneapolis Planning Commission, 1976.
- Worskett, Roy. The Character of Towns: An Approach to Conservation. London: The Architectural Press, 1969.
- Wright, Frank Lloyd. The Living City. New York: Plume Books, 1958.
- Zoning Code: City of Minneapolis. Tallahassee: Municipal Code Corporation, 1976.

Illustration Credits

Figure 1-8	Downtown Edges	Uncopyrighted Material
Figure 1-14	Architectural Design	Uncopyrighted Material
Figure 1-15	Architectural Design	Uncopyrighted Material
Figure 2-3	Hurd Aerial Photos	Uncopyrighted Material
Figure 2-10	St. Paul, Falcon Heights, Roseville Zoning Map	Uncopyrighted Material
Figure 2-18	Falcon Heights Zoning Code	Uncopyrighted Material
Figure 2-29	Falcon Heights Zoning Code	Uncopyrighted Material
Figure 2-37	Back Bay Development Plan	Uncopyrighted Material
Figure 2-44	Boston Zoning Map	Uncopyrighted Material
Figure 3-8	M.B. Group, Boston	Uncopyrighted Material
Figure 3-28	Loring Park Development Progress Report	Uncopyrighted Material
Figure 3-29	Loring Park Development Progress Report	Uncopyrighted Material
Figure 3-31	Loring Park Urban Design Plan	Uncopyrighted Material
Figure 3-32	Loring Park Urban Design Plan	Uncopyrighted Material
Figure 3-33	Loring Park Development Progress Report	Uncopyrighted Material
Figure 3-34	Loring Park Urban Design Plan	Uncopyrighted Material
Figure 3-35	Loring Park Urban Design Plan	Uncopyrighted Material
Figure 3-36	Loring Park Development Progress Report	Uncopyrighted Material
Figure 3-37	Loring Park Development Progress Report	Uncopyrighted Material
Figure 3-38	Minneapolis Tribune	Uncopyrighted Material
Figure 4-6	Downtown Edges	Uncopyrighted Material
Figure 4-7	Downtown Edges	Uncopyrighted Material

Figure 4-9	An Improvement Plan for Elliot Park	Uncopyrighted Material
Figure 4-10	An Improvement Plan for Elliot Park	Uncopyrighted Material
Figure 4-11	An Improvement Plan for Elliot Park	Uncopyrighted Material
Figure 4-12	An Improvement Plan for Elliot Park	Uncopyrighted Material
Figure 4-13	An Improvement Plan for Elliot Park	Uncopyrighted Material
Figure 4-14	Housing Generated by User Needs	Uncopyrighted Material
Figure 4-15	Housing Generated by User Needs	Uncopyrighted Material
Figure 5-4	Minneapolis Chamber of Commerce	Uncopyrighted Material
Figure 5-5	Metropolitan Planning Guide	Uncopyrighted Material
Figure 5-7	Minneapolis Tribune	Uncopyrighted Material
Figure 5-8	Central Community Plan	Uncopyrighted Material
Figure 5-10	Metro Center '85	Uncopyrighted Material
Figure 5-11	Metro Center '85	Uncopyrighted Material
Figure 5-12	Metro Center '85	Uncopyrighted Material
Figure 5-23	Metro Center '85	Uncopyrighted Material
Figure 5-15	Minneapolis Zoning Code	Uncopyrighted Material
Figure 5-17	Improvement Plan for Elliot Park	Uncopyrighted Material
Figure 5-18	Central Community Plan	Uncopyrighted Material
Figure 5-19	Minneapolis Zoning Code	Uncopyrighted Material