

MIT Open Access Articles

Climate Interactive: The C-Roads Climate Policy Model

The MIT Faculty has made this article openly available. **Please share** how this access benefits you. Your story matters.

Citation: Sterman, John et al. "Climate Interactive: The C-ROADS Climate Policy Model." *System Dynamics Review* 28.3 (2012): 295–305.

As Published: <http://dx.doi.org/10.1002/sdr.1474>

Publisher: Wiley Blackwell

Persistent URL: <http://hdl.handle.net/1721.1/77626>

Version: Author's final manuscript: final author's manuscript post peer review, without publisher's formatting or copy editing

Terms of use: Creative Commons Attribution-Noncommercial-Share Alike 3.0



Climate Interactive: The C-ROADS Climate Policy Model

John Sterman^{a,d}, Thomas Fiddaman^{b,d}, Travis Franck^{c,d}, Andrew Jones^d,
Stephanie McCauley^d, Philip Rice^d, Elizabeth Sawin^d, Lori Siegel^d

The Climate Policy Challenge

In 1992 the nations of the world created the United Nations Framework Convention on Climate Change (UNFCCC) to negotiate binding agreements to address the risks of climate change. Nearly every nation on Earth committed to limiting global greenhouse gas (GHG) emissions to prevent “dangerous anthropogenic interference in the climate system,”¹ which is generally accepted to mean limiting the increase in mean global surface temperature to 2°C above preindustrial levels.² High hopes were dashed at the 2009 Copenhagen climate conference when face-to-face negotiations among heads of state collapsed. Instead, nations were encouraged to make voluntary pledges to reduce their emissions. Those pledges currently fall significantly short of what is needed (UNEP 2010) while GHG emissions have risen to record levels despite the great recession that began in 2008.

Negotiations have failed even though scientific understanding of climate change and the risks it poses have never been stronger. In 2007 the Intergovernmental Panel on Climate Change (IPCC) concluded in its Fourth Assessment Report (AR4) that “Warming of the climate system is unequivocal” and “Most of the observed increase in global average temperatures since the mid-20th century is *very likely* due to the observed increase in anthropogenic GHG concentrations” (IPCC 2007, AR4 *Summary for Policymakers*, 2, 5; emphasis in the original).

¹ unfccc.int/essential_background/convention/background/items/1349.php

² The Bali Declaration first articulated the 2°C target (www.climate.unsw.edu.au/news/2007/Bali.html). More recent statements by the UNFCCC Secretariat call for no more than 1.5°C (unfccc.int/files/press/press_releases_advisories/application/pdf/pr20110606sbs.pdf).

^a Corresponding author: MIT Sloan School of Management, 100 Main Street, Room E62-436, Cambridge MA 02139 USA. jsterman@mit.edu

^b Ventana Systems, Bozeman, MT, USA

^c MIT Sloan School of Management, Cambridge, MA, USA

^d Climate Interactive, Washington DC, USA

The failure of global negotiations can be traced to the gap between the strong scientific consensus on the risks of climate change and widespread confusion, complacency and denial among policymakers, the media and the public (Sterman 2011). Even if policymakers understood the risks and dynamics of climate change—and many do not—in democracies, at least, the ratification of international agreements and passage of legislation to limit GHG emissions requires grass-roots political support.

Historically, information about climate dynamics and risks comes to policymakers, negotiators and the public in the form of reports based on the results of advanced general circulation models such as those used by the IPCC. Such models are essential in developing reliable scientific knowledge of climate change and its impacts. However, these models are opaque and expensive, and neither available to nor understandable by nonspecialists. The cycle time for creating and running scenarios is too long to allow real-time interaction with the models. Consequently, policymakers, educators, business and civic leaders, reporters and the general public often rely on their intuition to assess the likely impacts of emissions reduction proposals. However, intuition, even among experts, is highly unreliable when applied to understanding how proposals affect likely future GHG concentrations, temperatures, sea level, and other impacts.

Research shows common mental models lead to systematic and consequential errors in people's assessments of likely climate dynamics (Sterman 2011, 2008; Sterman and Booth Sweeney 2007, 2002; Moxnes and Saysel 2009). These errors are caused neither by poor training in science nor by the complexity of the climate: even highly educated people with significant training in Science, Technology, Engineering or Mathematics (STEM) consistently err in understanding much simpler, familiar systems such as bathtubs, bank accounts and compound interest (Booth Sweeney and Sterman 2000, 2007, Cronin, Gonzalez and Sterman 2009, Brunstein *et al.* 2010), including difficulty understanding processes of accumulation, feedback, time delays and nonlinearities (Sterman 1994). Because these errors are not the consequence of unfamiliarity with climate science they cannot be corrected by presenting people with more information on climate change. Interactive learning, through which people can use

simulation models as management flight simulators to discover, *for themselves*, how complex systems behave is required to improve people's mental models (Corell *et al.* 2009, Sterman 2011, 2000; Morecroft and Sterman 1994).

Poor understanding of complex systems not only afflicts the public, but the negotiators themselves. In 2008, Christiana Figueres, then lead negotiator for Costa Rica, and named executive secretary of the UNFCCC in 2010, commented

“Currently, in the UNFCCC negotiation process, the concrete environmental consequences of the various positions are not clear to all of us...There is a dangerous void of understanding of the short and long term impacts of the espoused... unwillingness to act on behalf of the Parties” (personal communication, Sept. 2008).

The C-ROADS (Climate Rapid Overview And Decision Support) model is designed to address these issues and build shared understanding of climate dynamics in a way that is solidly grounded in the best available science and rigorously nonpartisan, yet understandable by and useful to nonspecialists, from policymakers to the public. C-ROADS:

- is based on the best available peer-reviewed science and calibrated to state-of-the-art climate models;
- tracks GHGs including CO₂, CH₄, N₂O, SF₆, halocarbons, aerosols and black carbon;
- distinguishes emissions from fossil fuels and from land use and forestry policies;
- allows users to select different business as usual (BAU) scenarios, or to define their own;
- enables users to capture any emissions reduction scenario for each nation portrayed;
- reports the resulting GHG concentrations, global mean temperature change, sea level rise, ocean pH, per capita emissions, and cumulative emissions;
- allows users to assess the impact of uncertainty in key climate processes;
- is easy to use, running on a laptop computer in seconds so users immediately see the impact of the scenarios they test;
- provides an independent, neutral process to ensure that different assumptions and scenarios can be made available to all parties;
- is freely available at climateinteractive.org.

Model structure and user interface

Here we provide a brief overview. Sterman *et al.* 2012 describe the model structure and behavior in detail; complete documentation is available at climateinteractive.org. C-ROADS is a

continuous time compartment model with an explicit carbon cycle, atmospheric stocks of other GHGs, radiative forcing, global mean surface temperature, sea level rise and surface ocean pH (Fig. 1). The carbon cycle and climate sectors (Fig. 2) evolved from the FREE (Feedback Rich Energy-Economy) model (Fiddaman 1997, 2002, 2007). C-ROADS explicitly models CO₂ and other GHGs, including methane (CH₄), nitrous oxide (N₂O), SF₆ and other fluorinated gases (PFCs and HFCs), each with its own emissions fluxes, atmospheric stock and lifetime.

C-ROADS includes a variety of climate-carbon cycle feedbacks, including feedbacks from global mean temperature to net primary production and ocean CO₂ uptake. We also include positive feedbacks involving methanogenesis, e.g., CH₄ from melting permafrost, but set the base-case gains of these feedbacks to zero because they are, at present, poorly constrained by data. Similarly, we assume no acceleration in ice discharge from Greenland or Antarctica beyond what has been observed to date. Consequently, C-ROADS is likely to underestimate future warming and sea level rise. Users can test any values they wish for these feedbacks. We revise the model as knowledge of climate-carbon cycle feedbacks and ice sheet dynamics improves.

C-ROADS simulations begin in 1850. The model is driven by historic CO₂ and GHG emissions and includes the impact of volcanoes and other forcings. Fig. 3 and Table 1 compare C-ROADS to data through 2010. The model tracks the data well. Fig. 4 compares C-ROADS to the temperature projections reported in AR4 across a range of emissions scenarios. The average error for 2100 is less than 0.1°C. The full documentation compares C-ROADS to history for other GHGs and radiative forcing, and to other projections and models.

The user interface enables rapid experimentation with different policies and parameters. On the main screen users can access instructions, a video tutorial, interactive model structure diagrams and documentation, then select the level of regional aggregation for emissions, including global totals, or 3, 6, or 15 different nations and regional blocs (Table 2). Users interested in examining the impact of emissions from nations not explicitly represented can do so by developing a spreadsheet specifying the emissions projections for these nations; C-ROADS

can read such files directly. Users then select a BAU scenario, choosing those of the IPCC or Energy Modeling Forum, or specifying their own. Users can also load prior simulations, carry out Monte-Carlo sensitivity analysis to assess uncertainty and analyze the contribution of any nation's proposals to global outcomes.

Next users define scenarios for anthropogenic CO₂ emissions from fossil fuels and land use and emissions of other GHGs through 2100 for individual countries and regional blocs (Fig. 5). Users enter projected emissions for each nation or bloc in one of three modes: numerically, graphically, or from an Excel spreadsheet. Users specify how emissions are set, including:

1. relative to a user-selected base year (e.g., emissions in 2020 will be 17% below the 2005 value);
2. relative to BAU (e.g., emissions in 2020 will be 30% below the BAU value for that year);
3. relative to the carbon intensity of the economy of that nation or bloc (e.g., emissions in 2020 will reflect a 45% reduction in carbon intensity relative to 2005);
4. relative to per capita emissions for that nation or bloc (e.g., emissions in 2050 will reflect 10% growth in emissions per capita over the 2005 level for that nation or bloc).
5. other options detailed in the documentation.

Input modes, target years and emissions in each target year can differ for each nation and bloc.

Model output updates immediately. Users can select graphs and tables to display, by nation/bloc or globally, population and GDP, emissions of CO₂ and other gases, emissions per capita, the emissions intensity of the economy, CO₂ and CO_{2e} concentrations, CO₂ removal from the atmosphere, global mean surface temperature, sea level rise, ocean pH, and other indicators.

C-ROADS also offers interactive sensitivity analysis. Users can alter the values of key parameters, individually or in combination, and get immediate results.

Applications

Negotiators, policymakers, scientists, business leaders, and educators are among the many who use C-ROADS. Senior members of the US government including legislators and members of the executive branch have used C-ROADS. The US Department of State Office of the Special Envoy for Climate Change has developed an in-house capability to use C-ROADS and deploy it

in the UNFCCC and other bilateral and multilateral negotiations. Dr. Jonathan Pershing, the Deputy Special Envoy, commented

“The results [of C-ROADS] have been very helpful to our team here at the U.S. State Department...The simulator’s quick and accurate calculation of atmospheric carbon dioxide levels and temperatures has been a great asset to us. ...I have made use of the results in both internal discussions, and in the international negotiations....” (personal communication).

Former staff member Dr. Benjamin Zaitchik elaborates

“...[P]olicy makers and negotiators need to have a reasonable sense of what a particular action will mean for global climate, when considered in the context of other actions and policies around the world. Previously, we would make these calculations offline. We’d download emissions projections from a reliable modeling source, input them to an excel spreadsheet to adjust for various policy options, and then enter each proposed global emissions path into a model like MAGICC to estimate the climate response. This method...was time consuming and opaque: in the end we had a set of static graphs that we could bring into a meeting, but we couldn’t make quick adjustments on the fly. With C-ROADS, we can adjust policy assumptions in real-time, through an intuitive interface. This makes it much easier to assess the environmental integrity of various proposed emissions targets and to discuss how complementary emissions targets might achieve a climate goal....” (personal communication).

C-ROADS is also used in China, through Tsinghua University, where it has been disaggregated to include drivers of CO₂ emissions at the provincial level using assumptions about total energy use and fuel mix.

C-ROADS analysis was included in a United Nations Environment Program assessment of “the emissions gap” (UNEP 2010, 2011). The study found

“A ‘gap’ is expected in 2020 between emission levels consistent with a 2° C limit and those resulting from the Copenhagen Accord pledges...If the aim is to have a “likely” chance (greater than 66 per cent) of staying below the 2° C temperature limit, the gap would range from 5-9 GtCO₂e, depending on how the pledges are implemented.”

Where UNEP assesses the gap only through 2020, emissions beyond 2020 largely determine the climate impacts: to limit expected warming to the 2°C target emissions must fall approximately 70% below 2005 levels by 2050. The C-ROADS “Climate Scoreboard” analysis (Fig. 6) finds a large and growing gap through 2100 between the emissions needed limit expected warming to 2°C and emissions under current confirmed proposals. Even the optimistic

“potential proposals” scenarios fail to reach the target. The full analysis is available via the interactive “Climate Scoreboard” widget (climatescoreboard.org). The scoreboard is updated when pledges are made or modified, or the model is updated.

C-ROADS is also useful in education. A free online version, C-Learn is widely used in classrooms. C-ROADS and C-Learn are also used in an interactive role-play simulation of the global climate negotiations entitled *World Climate* (Sterman *et al.* 2011). Participants playing the roles of major nations negotiate proposals to reduce emissions, using C-ROADS to provide immediate feedback on the impacts of their proposals. Participants learn about the dynamics of the climate and impacts of proposed policies in a way that is consistent with the best available peer-reviewed science but that does not prescribe what should be done. *World Climate* has been used successfully with groups including students, business executives and political leaders. Instructions and all materials needed to run *World Climate* are freely available at climateinteractive.org.

C-ROADS is also the core model in the Climate CoLab (Malone *et al.* 2011), which “seeks to harness the collective intelligence of contributors from all over the world to address global climate change” (climatecolab.org). Anyone with Internet access can create proposals to address the risks of climate change, simulate their impacts using C-ROADS and other models, and debate the merits of each proposal.

Limitations and Extensions

C-ROADS enables decision-makers, educators, the media, and the public to quickly assess important climate impacts of particular national, regional or global emissions scenarios and to learn about the dynamics of the climate.

As with any model, C-ROADS is not appropriate for all purposes. To be able to run in about a second on standard laptops, the carbon cycle and climate sectors are globally aggregated. Thus C-ROADS cannot be used to assess climate impacts at regional or smaller scales.

C-ROADS takes future population, economic growth, and GHG emissions as scenario inputs

specified by the user and currently omits the costs of policy options and climate change damage. Many users, particularly those involved in negotiations, value the ability to specify pledges and proposals exogenously. But GHG emissions result from complex interactions of energy demand, production, prices, technology, learning and scale economies, regulations and government policies. To address these issues, we have developed a new model, En-ROADS, that endogenously generates energy use, fuel mix, and GHG emissions. Stocks of energy producing and consuming capital determine energy production and consumption by fuel type. The model includes construction and planning delays for the development of new energy sources and the possibility of retrofits and early retirement for existing capital stocks. The costs of each energy source are endogenous, including resource depletion and supply constraints that raise costs, and R&D, learning curves, and other feedbacks that can lower costs. Users can test a wide range of policies including carbon prices, regulatory constraints and subsidies for specific technologies. Users can also vary key parameters governing resource availability, technical breakthroughs, cost reductions, construction times and lifetimes for new plant, the potential for efficiency and retrofits, etc. Like C-ROADS, En-ROADS simulates in seconds on an ordinary laptop.

Through such interactive, transparent and fully documented simulators policymakers and the public can explore the risks and dynamics of climate change, helping to build shared understanding, grounded in the best available science, of the choices we face. We invite members of these communities, and particularly researchers and educators, to explore, use and improve these tools.

References

- Booth Sweeney, L., Sterman, J. (2000) Bathtub Dynamics: Initial Results of a Systems Thinking Inventory. *System Dynamics Review*, 16(4):249-294.
- Booth Sweeney, L., Sterman, J. (2007) Thinking About Systems: Students' and Their Teachers' Conceptions of Natural and Social Systems. *System Dynamics Review*, 23(2-3):285-312.
- Brunstein, A., Gonzalez, C., Kanter, S. (2010) Effects of Domain Experience in the Stock-Flow Failure. *System Dynamics Review*, 26(4):347-354.

- Corell, R., Lee, K., Stern, P. (2009) *Informing Decisions in a Changing Climate*. National Research Council, Washington, DC: National Academies Press. nap.edu.
- Cronin, M., Gonzalez, C., Sterman, J. (2009) Why Don't Well-Educated Adults Understand Accumulation? A Challenge to Researchers, Educators, and Citizens. *Organizational Behavior and Human Decision Processes*, 108(1):116-130.
- Fiddaman, T. (1997) Feedback Complexity in Integrated Climate-Economy Models. Ph.D. dissertation, Massachusetts Institute of Technology.
- Fiddaman, T. (2002) Exploring Policy Options with a Behavioral Climate-Economy Model. *System Dynamics Review*, 18(2):243-267.
- Fiddaman, T. (2007) Dynamics of Climate Policy. *System Dynamics Review*, 23(1):21-34.
- IPCC (2007) *Climate Change 2007: The Physical Science Basis*. Cambridge, UK: Cambridge University Press; ipcc.ch.
- Malone, T., Abelson, H., Karger, D., Klein, M., Sterman, J. (2011) *The Climate CoLab*. climatecolab.org.
- Morecroft, J., Sterman, J. (1994) *Modeling for Learning Organizations*. Portland, OR: Productivity Press.
- Moxnes, E., Saysel, A. (2009) Misperceptions of global climate change: information policies. *Climatic Change* 93(1-2):15-37.
- Sterman, J. (1994) Learning In and About Complex Systems. *System Dynamics Review*, 10(2-3): 291-330.
- Sterman, J. (2000) *Business Dynamics*. Irwin McGraw Hill: Boston, MA.
- Sterman, J. (2008) Risk Communication on Climate: Mental Models and Mass Balance. *Science*, 322: 532-533.
- Sterman, J. (2011) Communicating Climate Change Risks in a Skeptical World. *Climatic Change*, 108: 811-826.
- Sterman, J., Booth Sweeney, L. (2002) Cloudy Skies: Assessing Public Understanding of Climate Change. *System Dynamics Review*, 18(2):207-240.
- Sterman, J., Booth Sweeney, L. (2007) Understanding Public Complacency About Climate Change: Adults' Mental Models of Climate Change Violate Conservation of Matter. *Climatic Change*, 80:213-238.
- Sterman, J., Fiddaman, T., Franck, T., Jones, A., McCauley, S., Rice, P., Rooney-Varga, J., Sawin, E., Siegel, L. (2011) World Climate: A Role-Play Simulation of Global Climate Negotiations. Working Paper, MIT Sloan School of Management, [jsterman.scripts.mit.edu/docs/World Climate.pdf](http://jsterman.scripts.mit.edu/docs/World%20Climate.pdf).
- Sterman, J., Fiddaman, T., Franck, T., Jones, A., McCauley, S., Rice, P., Sawin, E., Siegel, L. (2012). Management Flight Simulators to Support Climate Negotiations. *Environmental Modelling and Software*.
- UNEP (2010) The Emissions Gap Report. United Nations Environment Programme (UNEP). Available at www.unep.org/publications/ebooks/emissionsgapreport/.
- UNEP (2011) Bridging the Emissions Gap. United Nations Environment Programme (UNEP). Available at www.unep.org/publications/ebooks/bridgingemissionsgap.

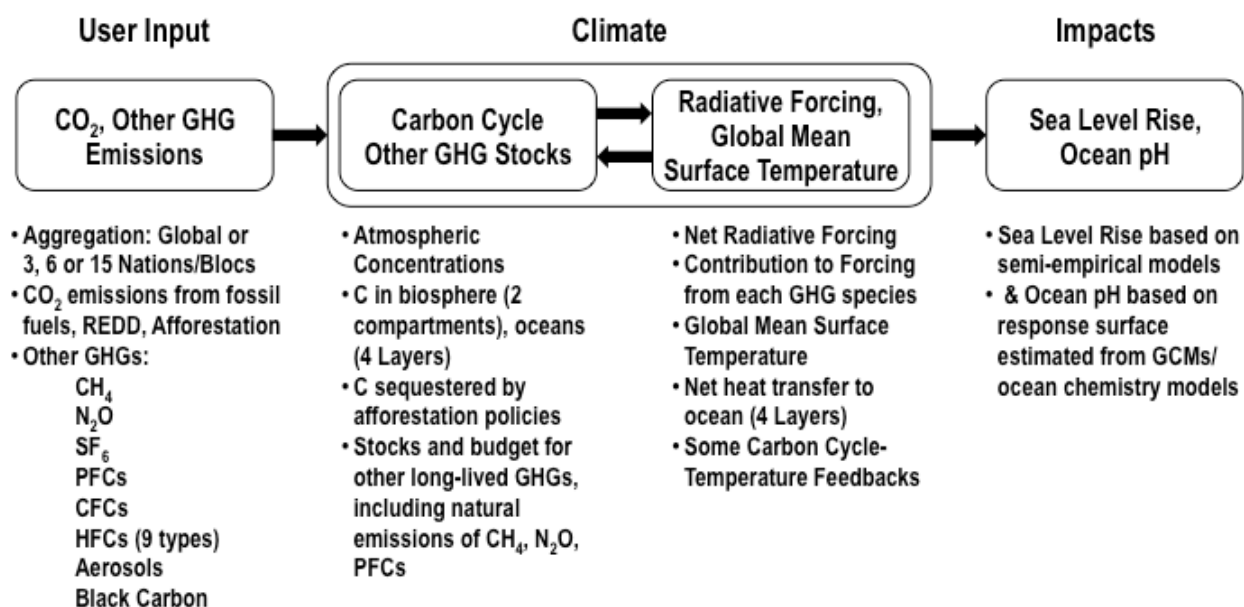

Figure 1. C-ROADS Overview. User-specified scenarios for GHG emissions affect atmospheric concentrations and the climate, which in turn drive impacts including sea level and ocean pH. The model includes climate-carbon cycle feedbacks.

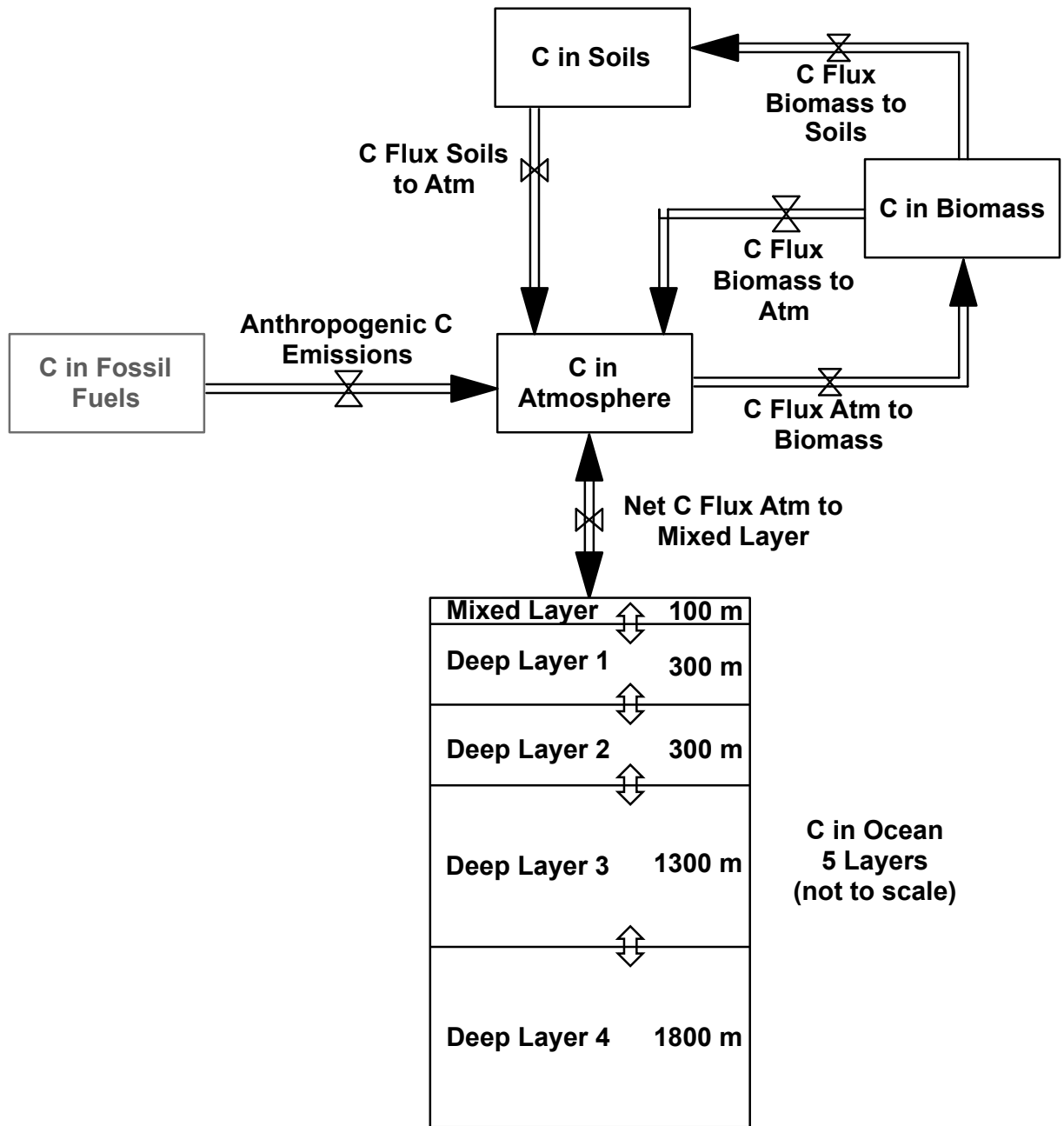

Figure 2. C-ROADS carbon cycle. Stocks of C in fossil fuels not treated explicitly. CH_4 fluxes and atmospheric stock and C fluxes and stocks due to deforestation/afforestation are represented explicitly but are aggregated in this simplified view.

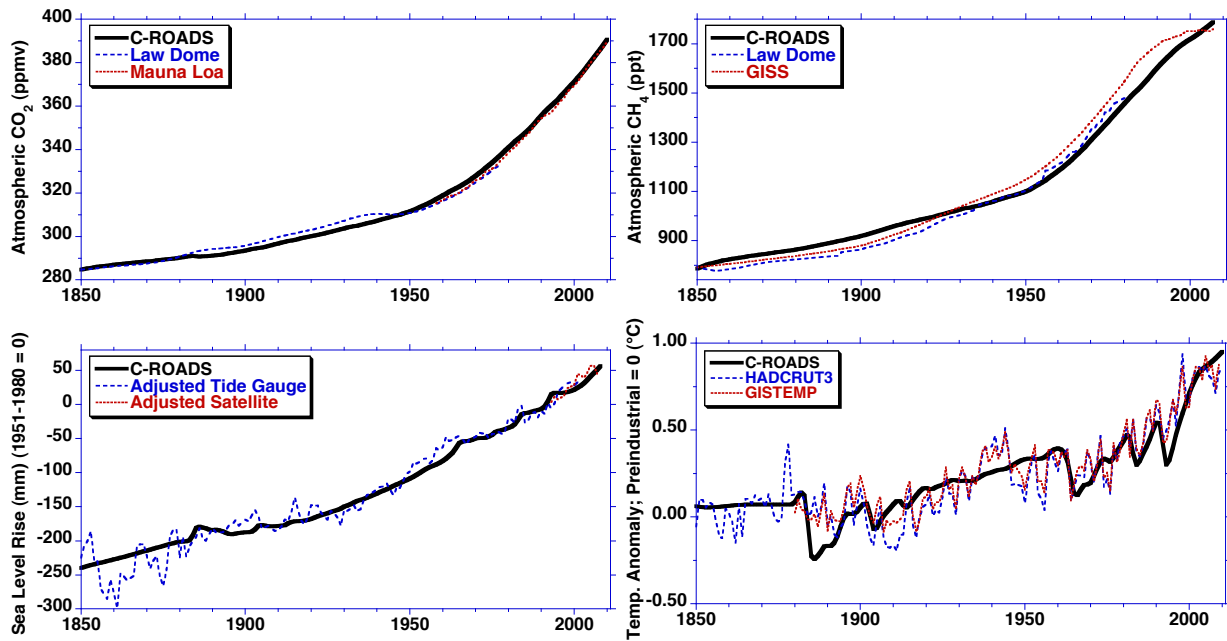

Figure 3. C-ROADS fit to historical data. Clockwise from top left: Atmospheric CO₂, CH₄, temperature anomaly, sea level.

	CO ₂ (ppm)	CH ₄ (ppt)	Temperature Anomaly (°C)	Sea Level Rise (mm)
Years	1850-2007	1850-2000	1850-2010	1850-2008
R ²	0.995	0.989	0.747	0.960
MAPE	0.63%	3.39%	NA ^a	NA ^a
RMSE	2.25	48.5	0.133	18.3
Theil Inequalities: ^b				
U ^M : Bias	0.02	0.10	0.00	0.00
U ^S : Unequal Variation	0.24	0.48	0.03	0.11
U ^C : Undequal Covariation	0.75	0.42	0.97	0.89

^a MAPE (Mean Absolute Percent Error) not defined for DT and SLR because the year defining zero is arbitrary.

^b Theil inequality statistics may not sum to one due to rounding. Sterman *et al.* 2012 provide details.

Table 1. Goodness of fit.

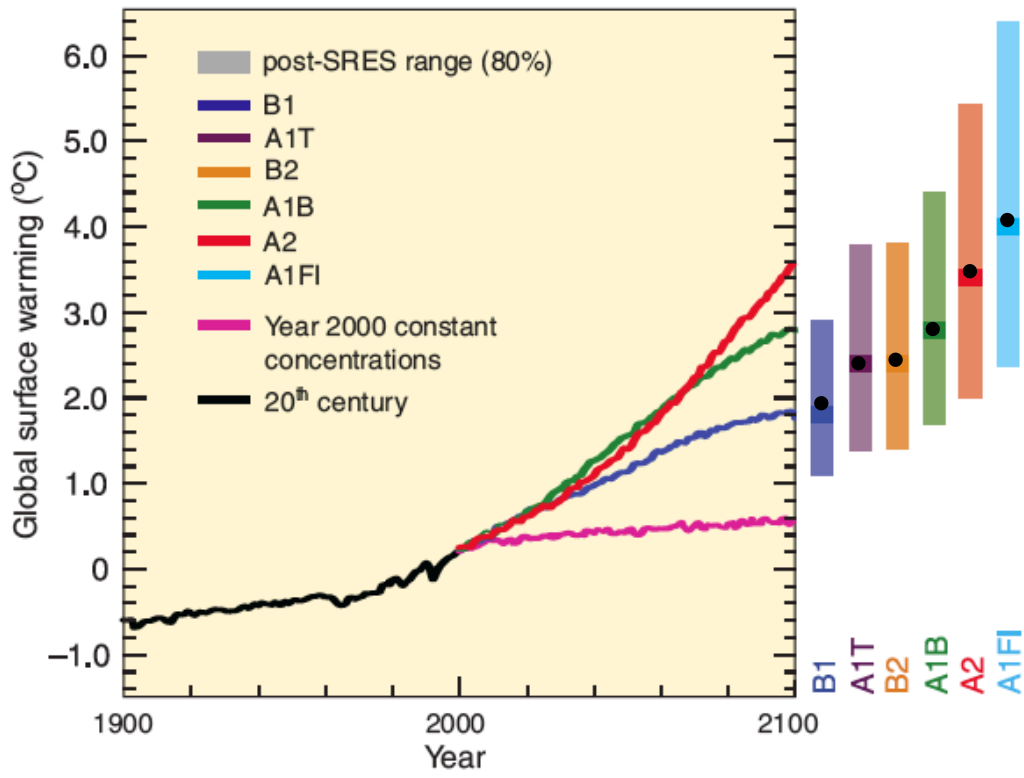

Figure 4. Temperature projections for 2100 and *likely* range from IPCC AR4 (SPM Fig. 5) vs. C-ROADS (black circles).

3 Regions ^a	6 Regions	15 Regions
<p>Developed All developed nations</p> <p>Developing A Rapidly developing nations (Brazil, China, India, Indonesia, Mexico, South Africa and other large developing Asian nations)</p> <p>Developing B Rest of world: least developed nations in Africa, Asia, Latin America, Middle East, Oceania</p>	<p>China</p> <p>European Union</p> <p>India</p> <p>United States</p> <p>Other Developed Nations Australia, Canada, Japan, New Zealand, Russia/FSU/ Eastern Europe, South Korea</p> <p>Other Developing Nations Brazil, Indonesia, Mexico, South Africa; Other Africa, Asia, Latin America, Middle East, Oceania</p>	<p>Australia</p> <p>Brazil</p> <p>Canada</p> <p>China</p> <p>European Union</p> <p>India</p> <p>Indonesia</p> <p>Japan</p> <p>Mexico</p> <p>Russia</p> <p>South Africa</p> <p>South Korea</p> <p>United States</p> <p>Developed non MEF^b nations Other Eastern Europe & FSU, New Zealand</p> <p>Developing non MEF nations Other Africa, Asia, Latin America, Middle East, Oceania</p>

^a The three region level of aggregation is available in C-Learn, the online version of C-ROADS.

^b Major Economies Forum on Energy and Climate; www.majoreconomiesforum.org.

Table 2. In addition to the global level, users may choose 3, 6 or 15 nation/region levels of aggregation.

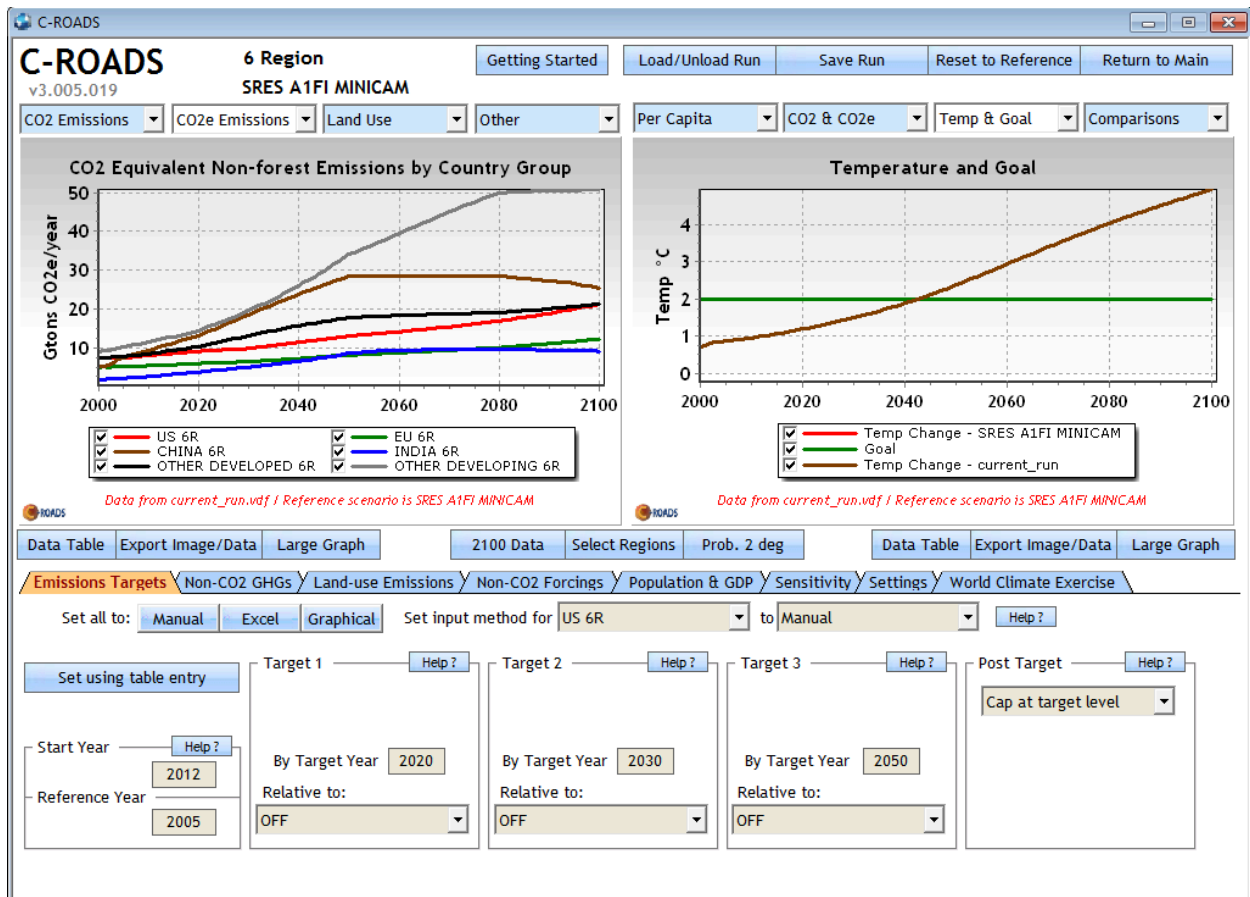

Figure 5. C-ROADS interface.

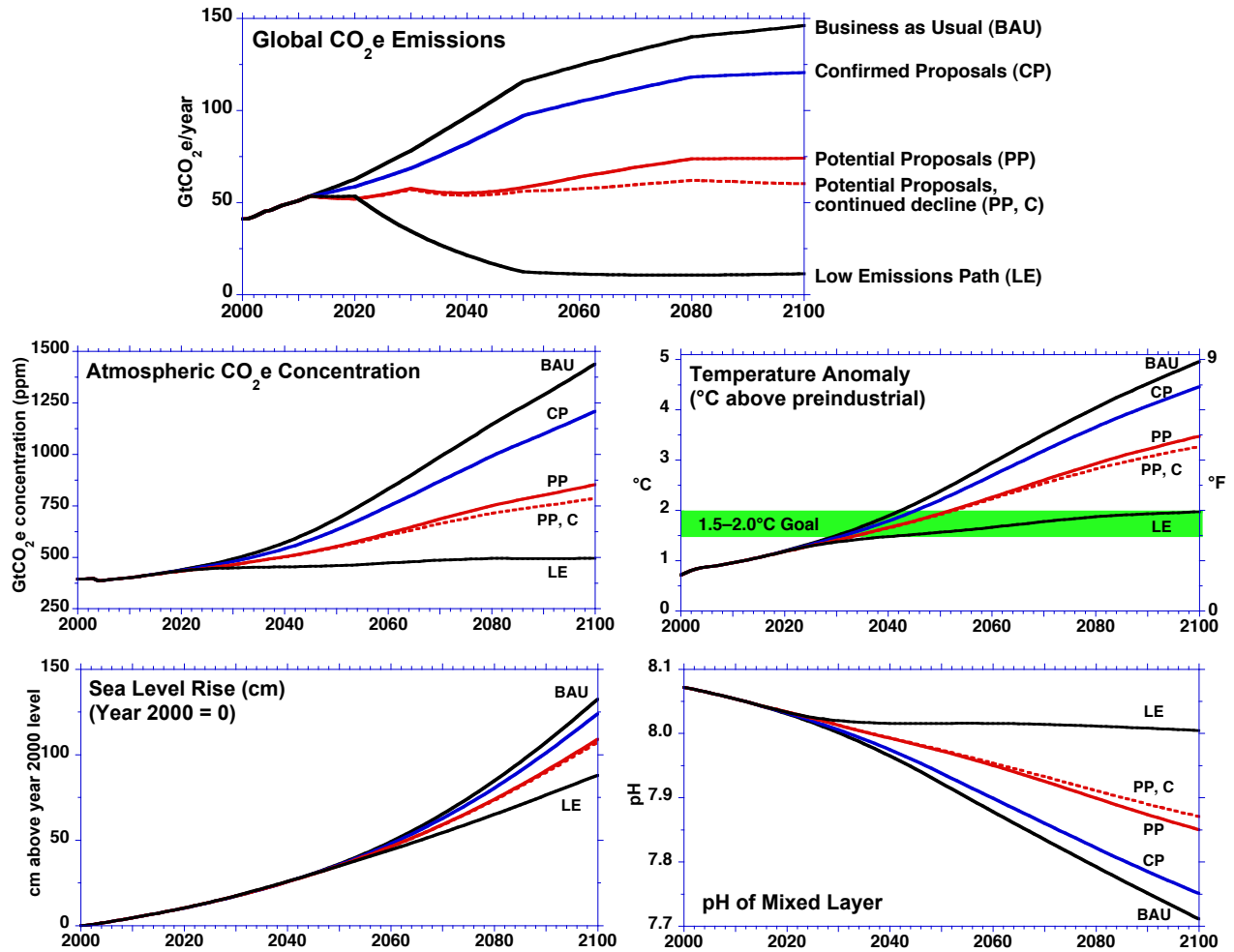

Figure 6. C-ROADS assessment of pledges under the Copenhagen Accord, as of December 2011. Results shown for BAU (A1FI), total confirmed proposals, potential proposals, and potential proposals assuming continued emissions decline after the pledge horizon. The “Low Emissions Path” yields expected warming of 2°C by 2100. climatescoreboard.org provides updates and documentation.