

AN INTEGRATED BUILDING SYSTEM

by

William C. H. Pan

Bachelor of Architecture
Massachusetts Institute of Technology
(1967)

SUBMITTED IN PARTIAL FULFILLMENT
OF THE REQUIREMENTS FOR THE
DEGREE OF MASTER OF
ARCHITECTURE

at the

MASSACHUSETTS INSTITUTE OF TECHNOLOGY
September, 1968

SIGNATURE OF AUTHOR.

Department of Architecture
June 17, 1968

CERTIFIED BY

Thesis Supervisor

ACCEPTED BY.

Chairman, Departmental Committee on Graduate Students

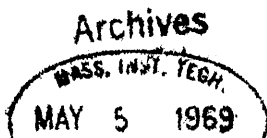

June 15, 1968

Dean Lawrence B. Anderson
School of Architecture and Planning
Massachusetts Institute of Technology
77 Massachusetts Avenue
Cambridge 39, Massachusetts

Dear Dean Anderson:

In partial fulfillment of the requirements for the degree of
Master of Architecture, I hereby submit the project entitled
"An Integrated Building System."

William C. H. Pan

Acknowledgements

The author gratefully acknowledges invaluable advice and assistance from the following people in the development of this thesis.

Professor Eduardo Catalano

Professor Waclaw Zalewski

Visiting Professor Yu-sing Jung

Mr. Charles Crowley, Mechanical Engineer

Abstract

The purpose of this thesis was to study an integrated building system for a multi-purpose building in an urban commercial center. The building system was conceived as a total system of environmental control, structure and building service cores.

The integrated building system consists of a four-way structural system supported on four columns 54 feet on centers.

The precast concrete truss unit is 6 feet by 6 feet planning module. The total structural floor depth is 4 feet and it allows ample space for all environmental control systems.

The primary vertical mechanical system is incorporated with columns. Various core elements and core arrangements are depending on the functions and occupancies.

TABLE OF CONTENTS

	PAGE
Title Page.....	1
Acknowledgements.....	3
Abstract.....	4
Table of Contents.....	5
Introduction.....	6
Design Criteria and Conditions.....	6
Design Proposal.....	8
The Structural Elements System.....	8
Construction Sequence.....	9
Service Elements System.....	10-12
Mechanical System	
Lighting	
Acoustics	
Electrical Systems	
Plumbing	
Service Cores.....	12
Photographs of Design.....	14-28
Summary.....	29
Conclusion.....	31
Appendix.....	32-37
Bibliography.....	38

Introduction

In the advanced technology of the twentieth century, mechanical and structural engineering have proceeded swiftly in the technological areas. The architects of the new generation should re-evaluate the present building conditions and develop a totally new approach toward an "Integrated Building System." Architect Koyonori Kikutake, a member of the Metabolist Group, describes a building as being composed of two basic elements: first, there is the structural elements system which determines the space itself; and secondly, the service elements system, which corresponds to living patterns, and is also subject to temporal changes in function.

The purpose of this thesis is to integrate these two basic elements by means of developing a type of integrated building system utilizing standardization to provide flexibility of function. For a multi-function building the author turns his attention to space grid structures for longer span.

Design Criteria and Conditions

The architect has the role of coordinating the design of various elements into a workable whole. A design solution may be described in terms of twelve basic elements, as follows: human needs, and activities, space, surfaces, vehicles,

goods, structure, mechanical systems, electrical systems, gas, lighting, acoustics and plumbing. This thesis emphasizes the structural elements and building service elements, such as mechanical, electrical, lighting, acoustics and plumbing as the major design criteria.

1. It was necessary to develop a structural floor system which would make it possible to create floor openings of varying sizes to integrate the service system elements within the floor depth.
2. The structure bay width should be ranging at less than 50 feet between column supports. Non-load bearing partitions should be installed on a planning module basis, allowing a variety of spaces in the structural bay. Cantilevers up to 1/3 of the space should be permissible in any direction.
3. The structural system material would be the reinforced concrete resulting in a completely fire-proof structure.
4. Core design and vertical circulation requirements would be designed according to the National Building Code. Building service elements systems may sometimes be incorporated in columns.

Design Proposal
The Structural
Elements System

The proposed structural system consists of module precast space units linked together by post stressing higher strength steel cables and supported by precast columns. It is desirable to use factory precast techniques which achieve a better dimensional control quality as well as reduced labor costs.

The components of the floor system consist of two elements, i.e. the space grid structural unit and the precast floor cover between four units. The structural unit module grid is 6'-0" square in plan and 3'-9½" depth allowing 2½" concrete floor topping to achieve a total depth 4'-0" for structural requirements. The unit itself weighs approximately one ton, and the weight (lbs/ft²) of the building is approximately 110. The configuration of the proposed structural units could transmit forces in more than two directions from a given point. Therefore, it is a fourway structural system. In practice the height of a double layer grid, the distance between the top and the bottom layers is $h = \frac{L}{20} - \frac{L}{25}$ of the span L. The structural units are cast in two weights by means of varying the size of the opening. The major opening of the unit is to provide for air duct

and the minor opening is for electrical installments and plumbing. A basic building unit consists of a structural bay from which cantilevers go in two directions. The possibility of varying the cantilever dimensions from 0 to 12 feet can achieve a fundamental flexibility in planning.

The structural planning network consists of three different spaces: the space for primary use is defined by a structural bay; the other two are the spaces between four structural bays or two structural bays. The latter two spaces are created by cantilever projection. It is structurally the most logical place for the service core to be located. This so-called "internal plug-in service" makes the planning network more flexible.

Construction Sequence

The sequence of construction of a typical floor system of units would be as follows:

1. Placement of structural units, one in the direction and grouting of joints between units.
2. Post-stressing bottom only pressure grouting.
3. Placement of precast column.
4. Erection of scaffolding at both ends.
5. Placement of a row of post-stressed units and grouting of joint between

units.

6. Post-stressing bottom and top when required and then pressure grouting.
7. Placement of precast floor system.
8. Placement of reinforced steel at the top of the system where required.
9. Pouring of floor slab topping.
10. Repeat step 1.

Service Elements
System

Mechanical System:

The mechanical system distributes itself integrally within the structural system. The calculation for the whole system is based upon the figures of the calculation for one quarter of a building unit. The primary air proposed for this type of building system is a single-duct high velocity system. Ceiling fan coil units are the secondary axillary cooling or heating system. It performs an ample air conditioning, corresponding to various loading conditions. Vertical supply air is incorporated within the columns and is to be used for five floors maximum. The mechanical equipment room should be located at a position which would be to the benefit of five floors up and down in both directions. Ceiling plenum serves as return air secondary ducts, which reduce cost and simplify its distribution.

Mechanical system data:

High velocity supply air: 4,000-4,500 FPM
per sq.ft.

Low velocity return air: 800 FPM and 85% of supply air.

Low velocity supply air: 800-1,000 FPM at the secondary branches duct.

Lighting:

Module lighting panel 5'x55' is installed at the base of a structural unit. Air diffusion light unit with four-foot fluorescent fixture is designed to handle 400-5,000 CFM. The module panel slopes up toward the center of the light fixture service as an indirect reflector to illuminate the space below. The integrated air distribution system with lighting could save 15% heat operation cost in the winter.

Acoustics:

The module light panel is covered by synthetic fiber material which is designed to have either sound absorbent or sound reflective treatments, depending upon the acoustics where required at a particular space. Sound barriers should be installed between the structural units of adjacent spaces.

Electrical Systems:

Electric cables and telephone service conduits are contained at the bottom of the floor surface. Small diameter knockout holes are located in the floor cover slab for service access.

Plumbing:

Hot and cold water supply, waste and ventilation are located in core shaft to serve toilets and janitor closets. Secondary pipe service, such as chilled-water supply and return and drainpipe, is contained in the columns. These pipes follow the same basic horizontal distribution pattern as the air system. All of the pipes are accessible and may be easily serviced and replaced.

Service Cores

In large scale buildings with uninterrupted square footage demands, the service core installed in the spaces where the "internal are plug-in service" network is already provided.

The area of influence of the service core is determined by code requirements from public buildings. The gross area served by a typical core is set at six bays equally 33,000 square feet. The service core contains two elements, i.e. toilet facilities and vertical circulation such as fire staircases and elevators. The other service element also included in the service core are transformer room telephone equipment room, maintenance room and switch gear room. The service core area can be varied, depending upon the service load.

The requirements for various service

elements are given below. They are approximate and will vary with occupancies.

Passenger elevators, one 5'x 7'-6"
elevator per 50,000 sq.ft. net floor area

Toilet fixtures (women), 1 W.C./45; 1
Lav/75

Toilet fixtures (men), 1 W.C./75;
1 Lav/75/ 1 urinal /30

Firestairs, occupancy, 1 person 100ft.,
unit exit width, 36" - 48",
no. of exits/floor - 2,
occupancy/unit exit - 150/floor,
travel distance - 150 ft.

Electric closet - 36 ft.²/30,000 ft.²

Janitor closet - 36 ft.²

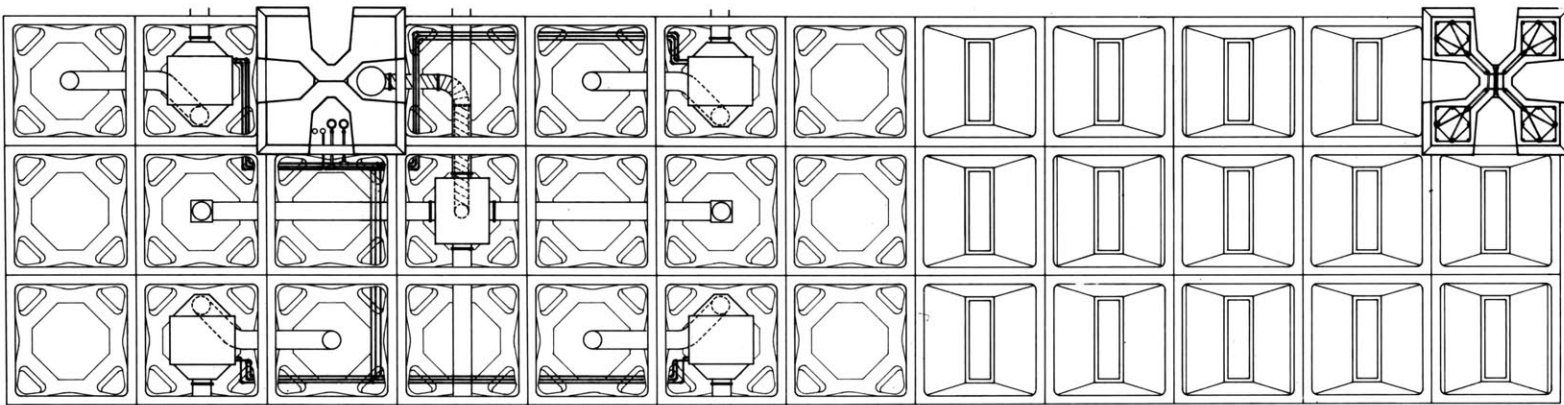
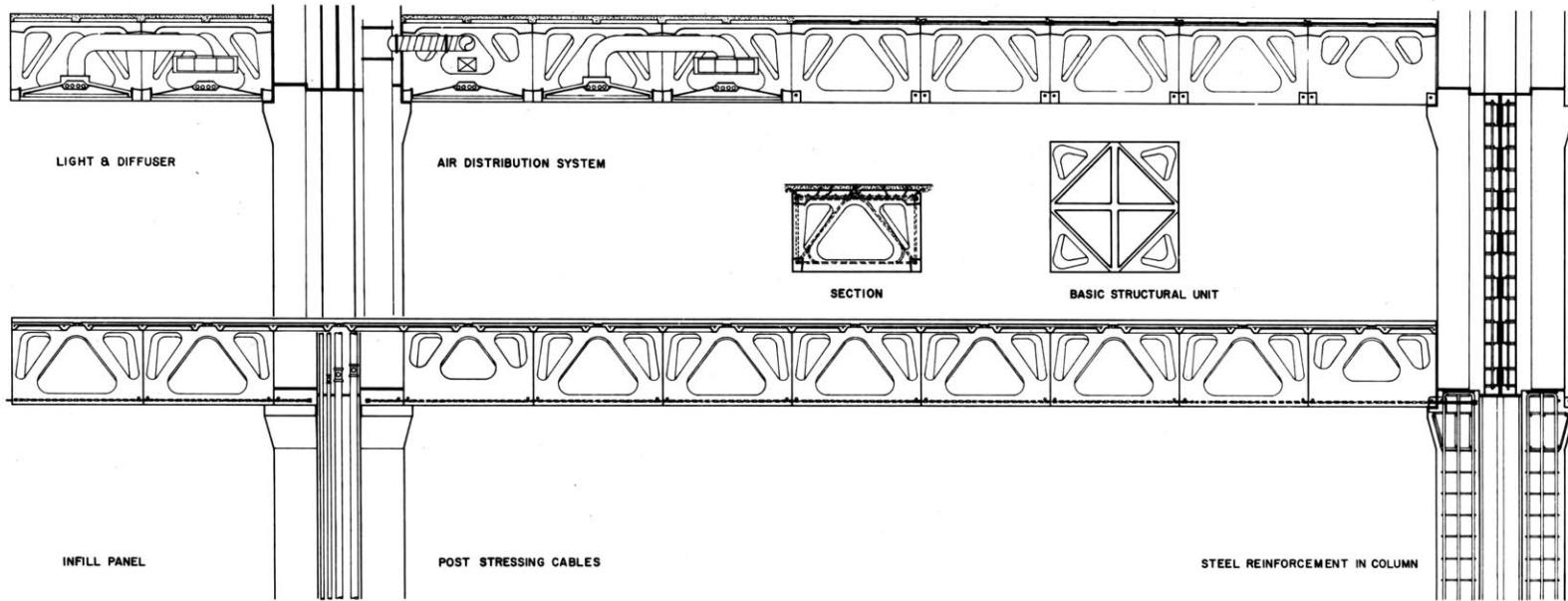

STRUCTURAL AND MECHANICAL COMPONENTS



REFLECTED CEILING PLAN

AN INTEGRATED BUILDING SYSTEM
MASTER OF ARCHITECTURE THESIS
 MASSACHUSETTS INSTITUTE OF TECHNOLOGY
 WILLIAM C. H. PAN FALL 1967

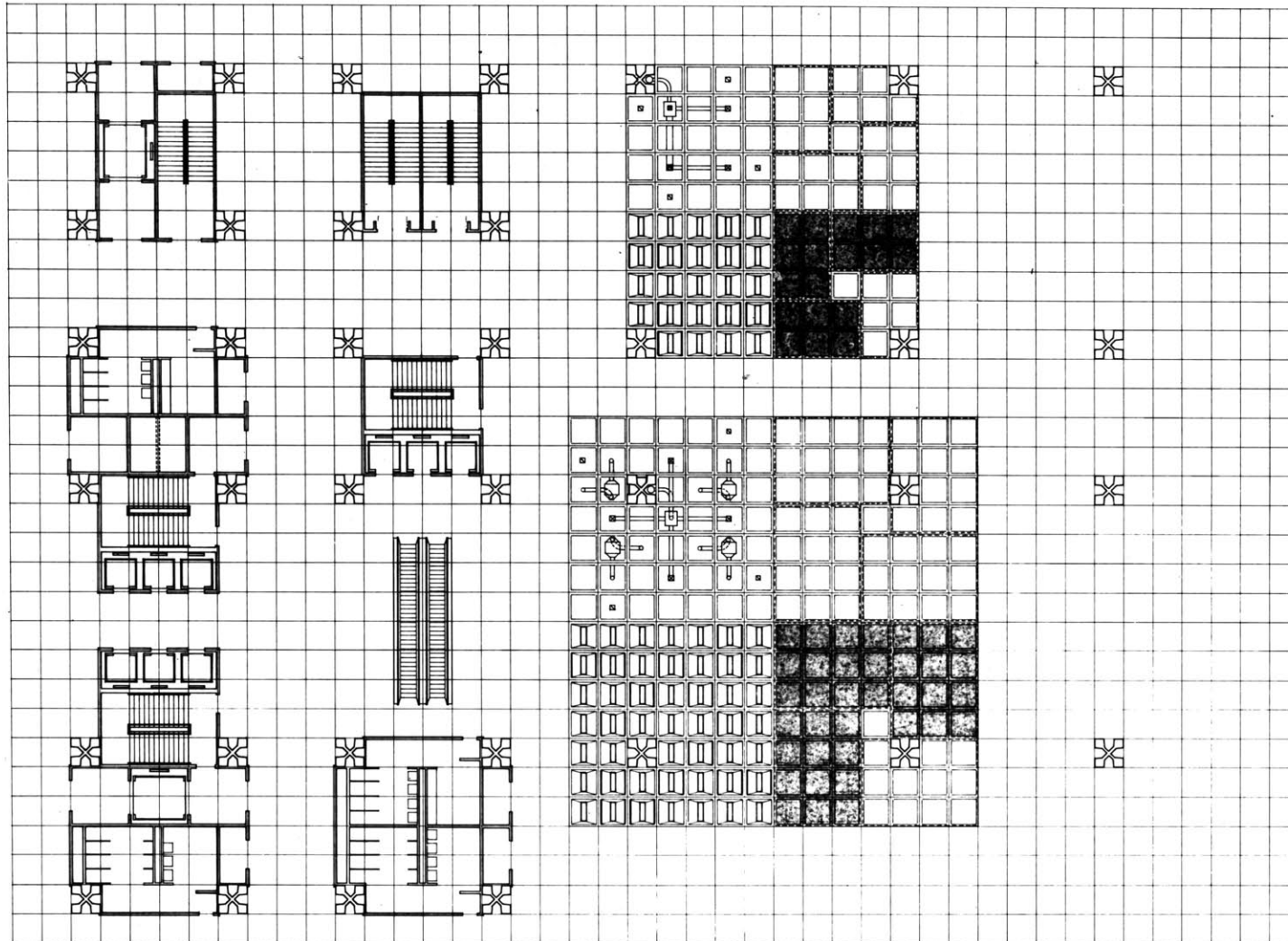

COMPONENT SYSTEMS

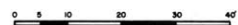

AN INTEGRATED BUILDING SYSTEM
MASTER OF ARCHITECTURE THESIS
 MASSACHUSETTS INSTITUTE OF TECHNOLOGY
 WILLIAM C. H. PAN FALL 1967

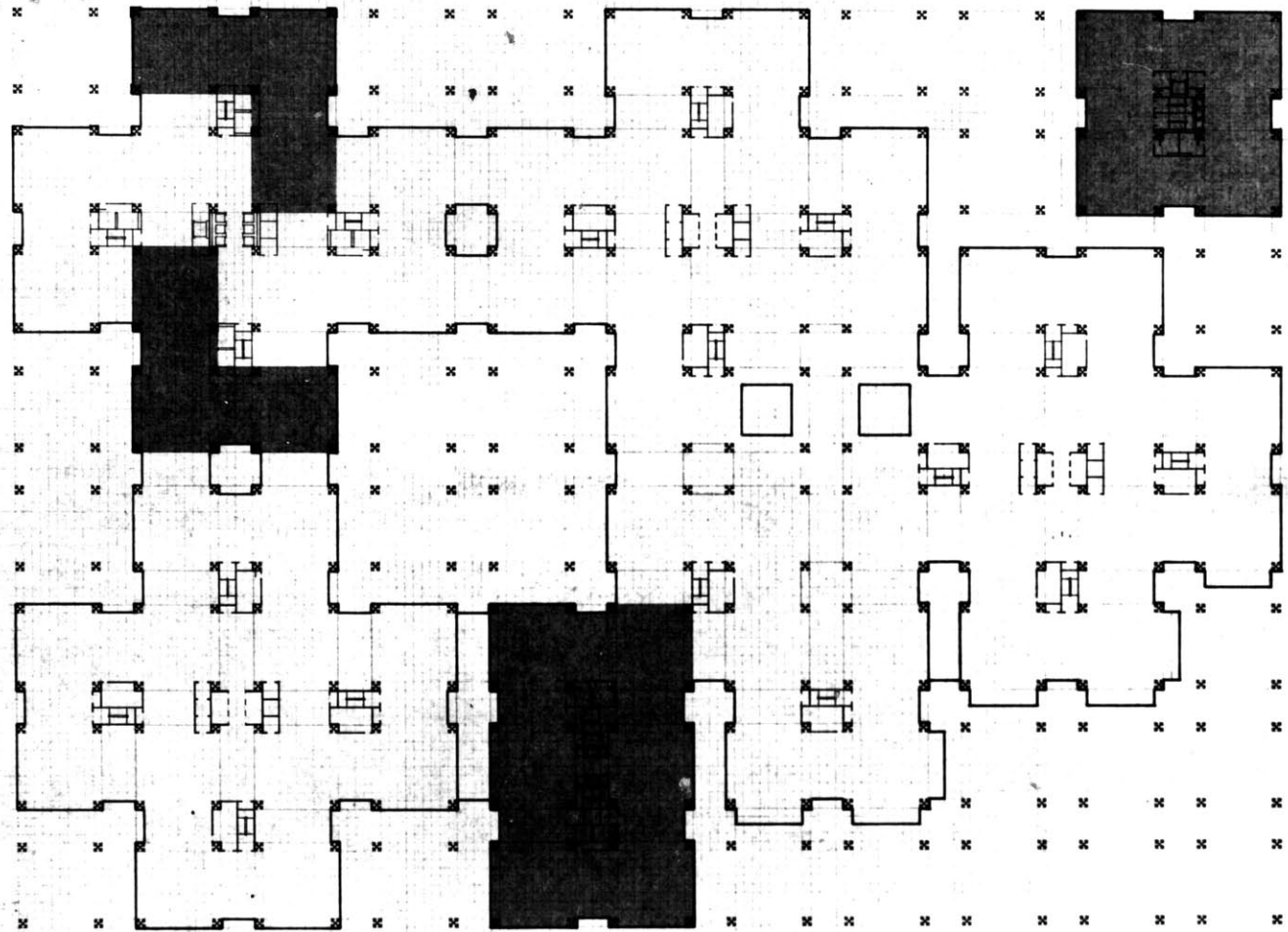

PLAN VARIATIONS



AN INTEGRATED BUILDING SYSTEM
MASTER OF ARCHITECTURE THESIS
MASSACHUSETTS INSTITUTE OF TECHNOLOGY
WILLIAM C. H. PAN FALL 1967

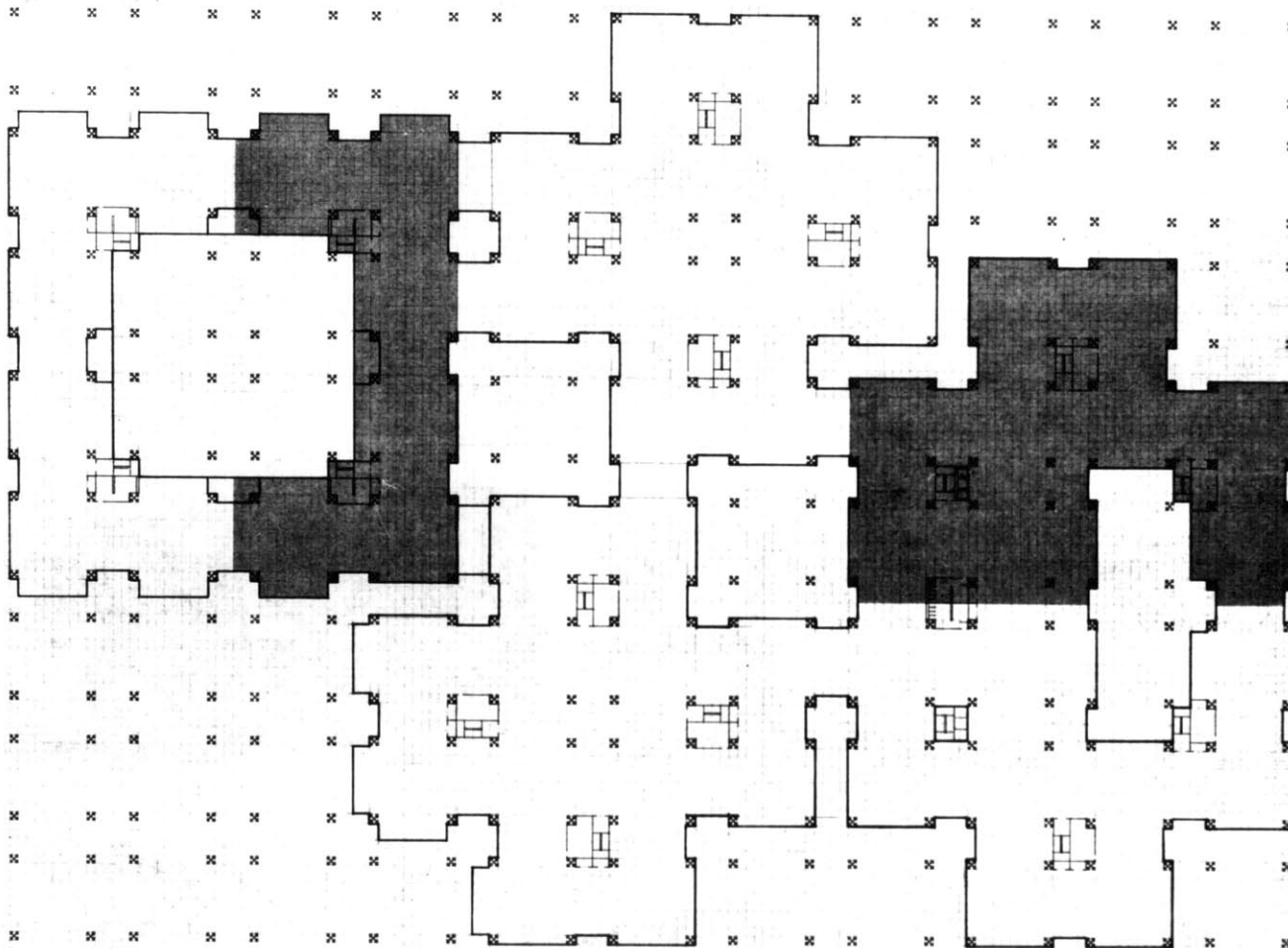

PLAN VARIATIONS



AN INTEGRATED BUILDING SYSTEM
MASTER OF ARCHITECTURE THESIS
MASSACHUSETTS INSTITUTE OF TECHNOLOGY
WILLIAM C. H. PAN FALL 1967

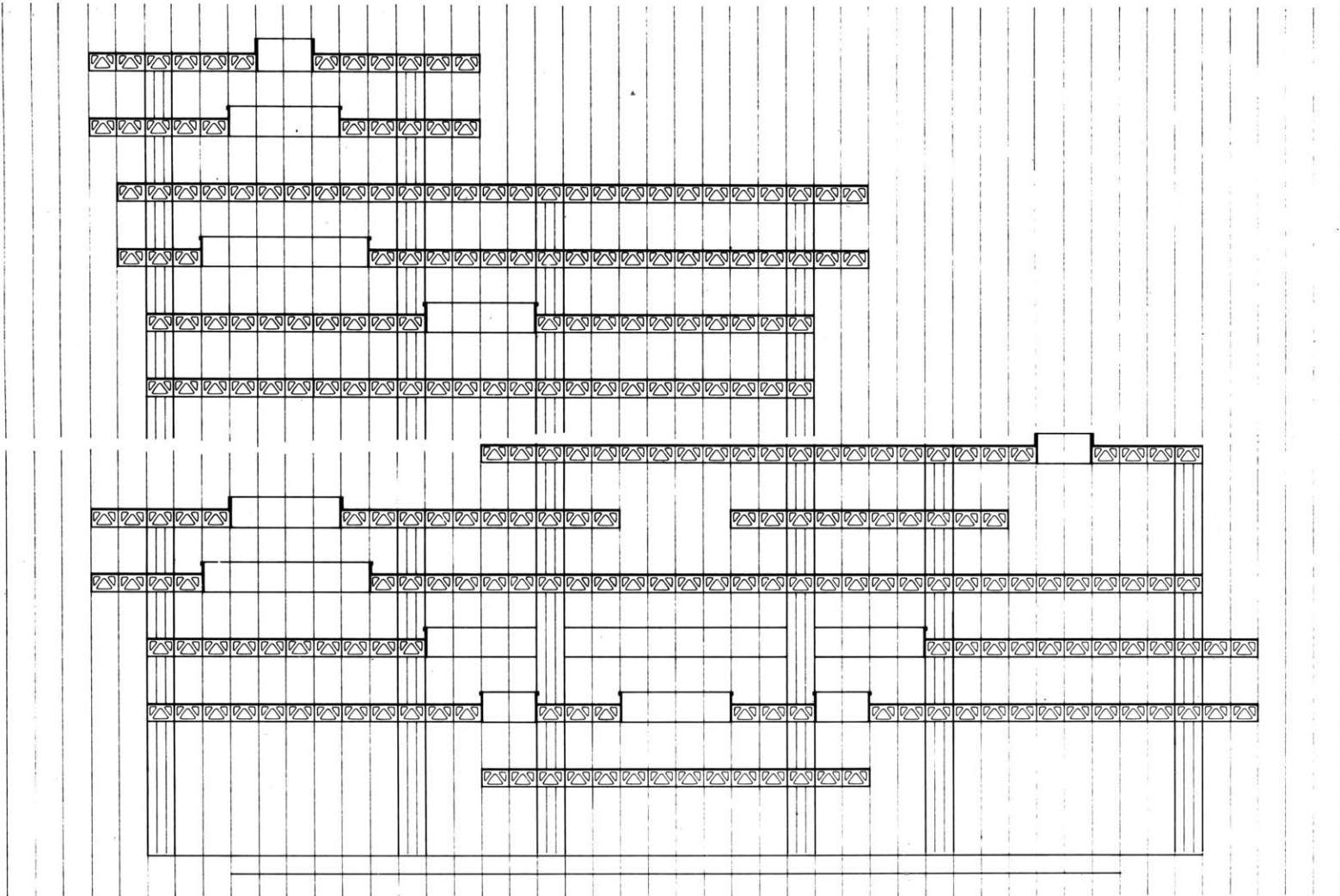

SECTION VARIATIONS

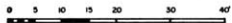

**AN INTEGRATED BUILDING SYSTEM
 MASTER OF ARCHITECTURE THESIS
 MASSACHUSETTS INSTITUTE OF TECHNOLOGY
 WILLIAM C. H. PAN FALL 1967**

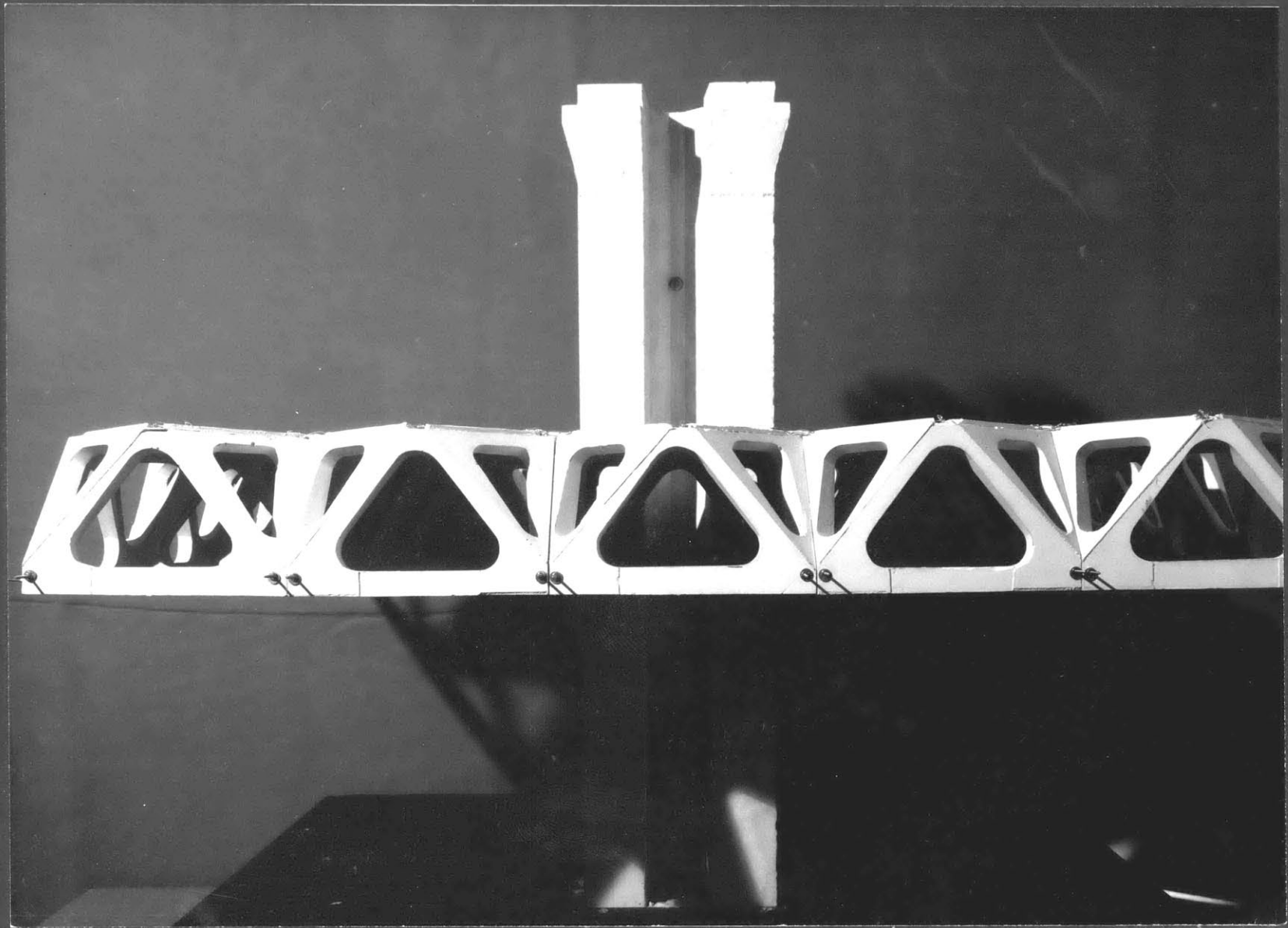

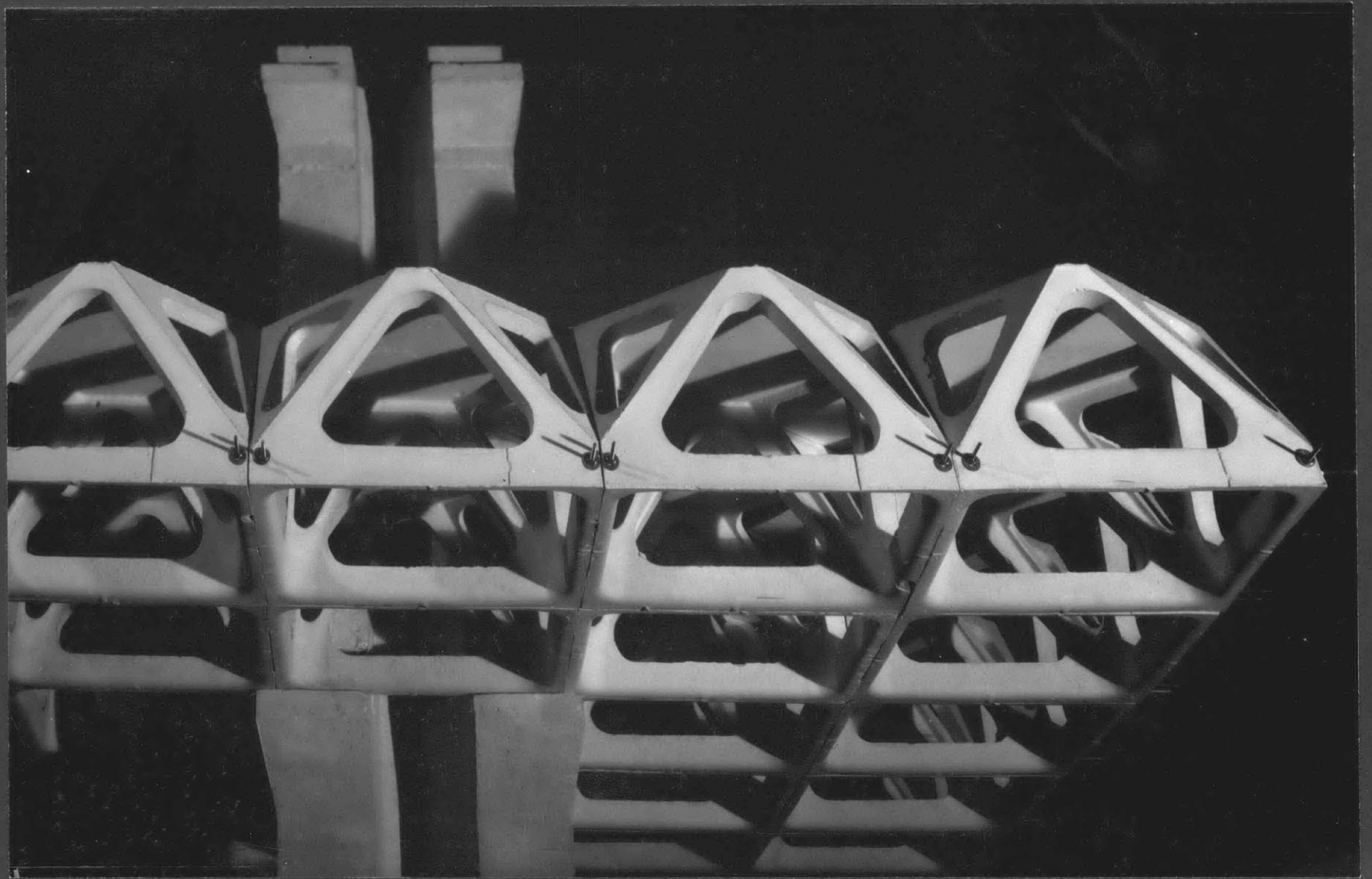

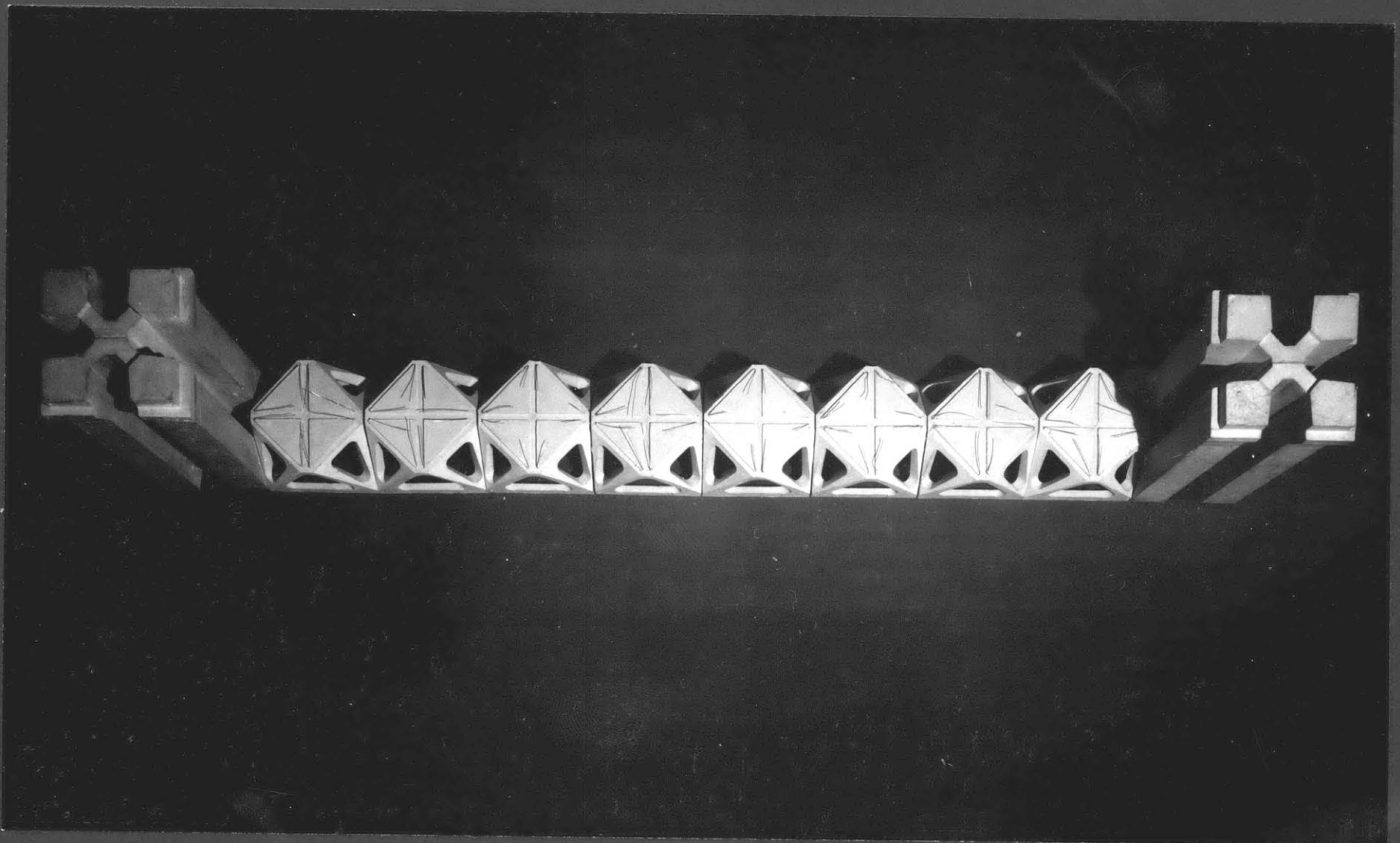

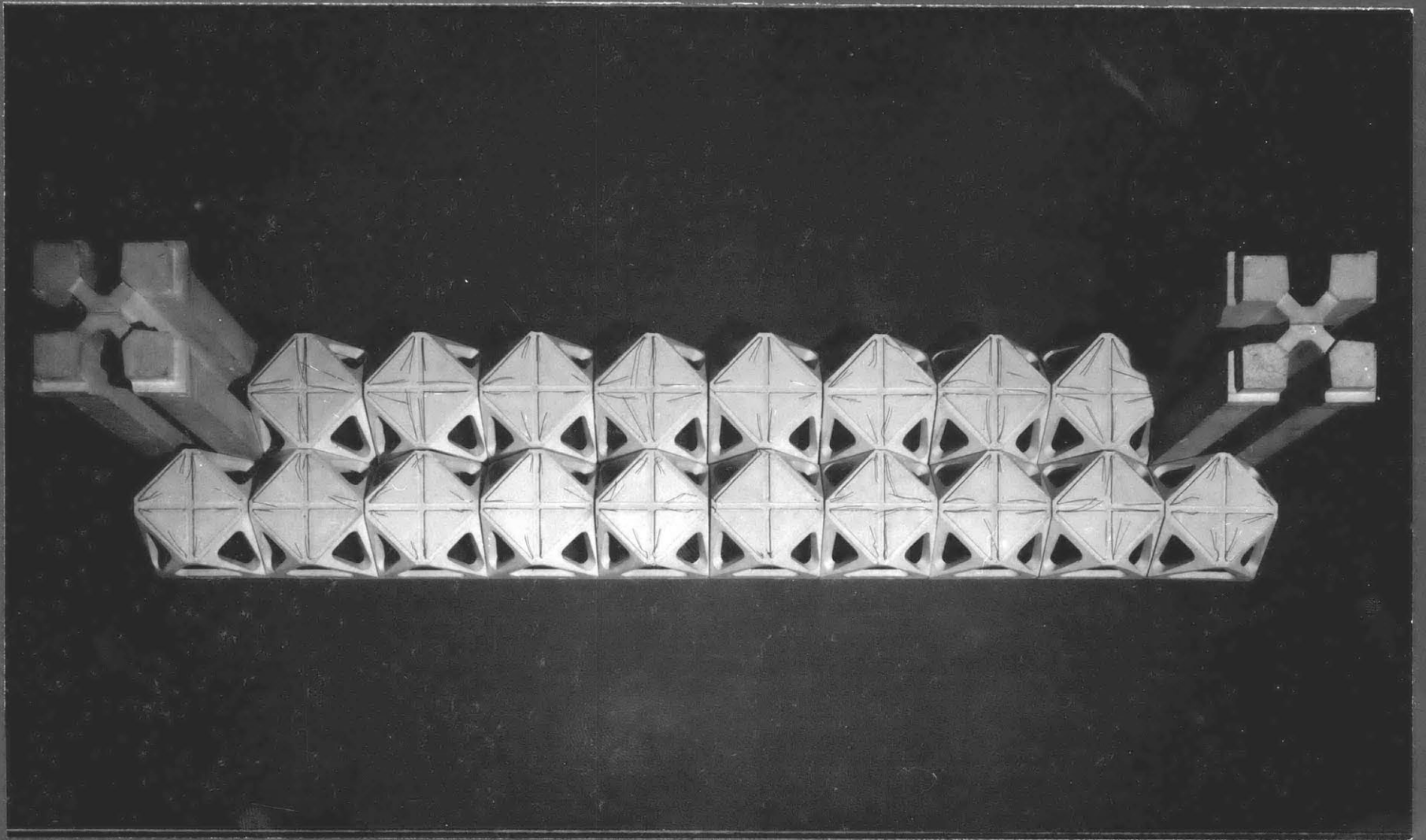

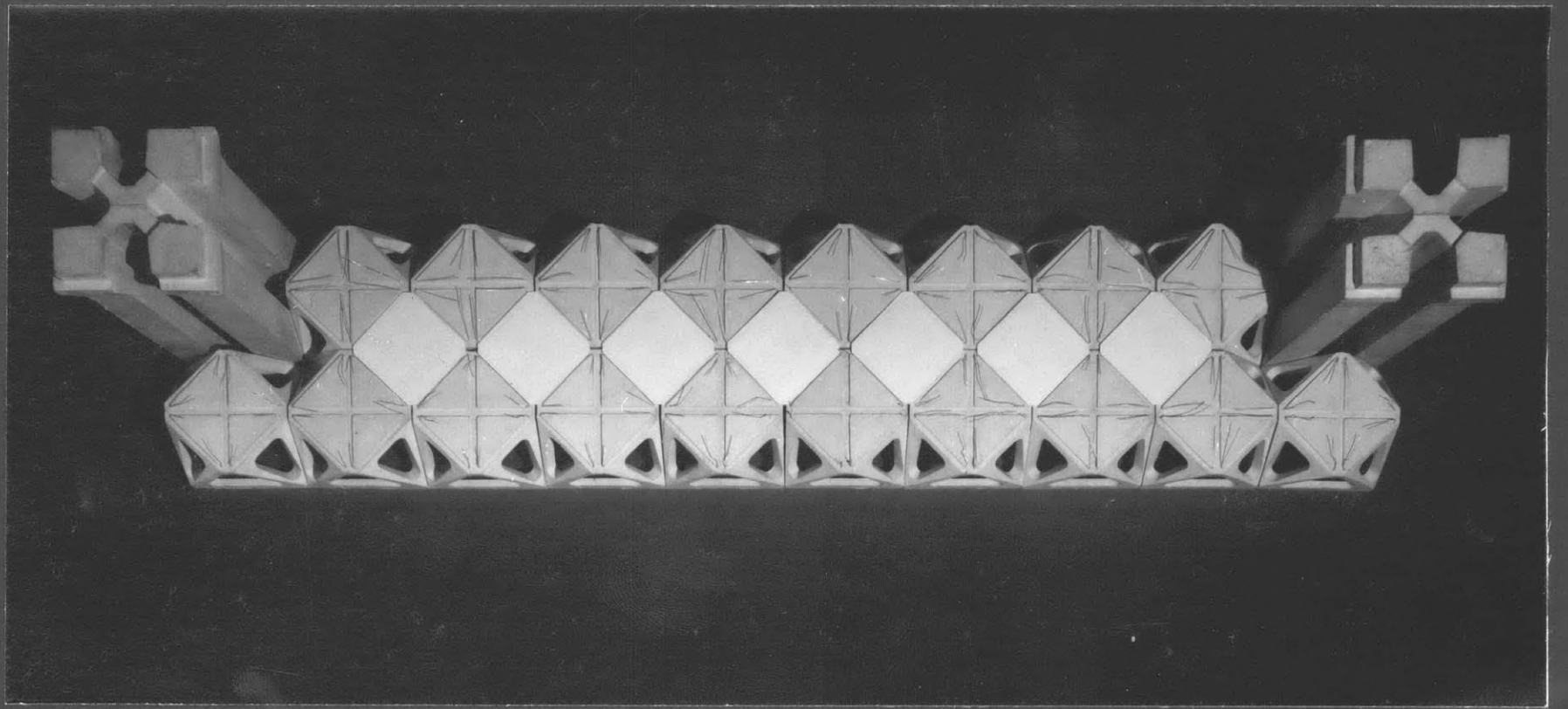

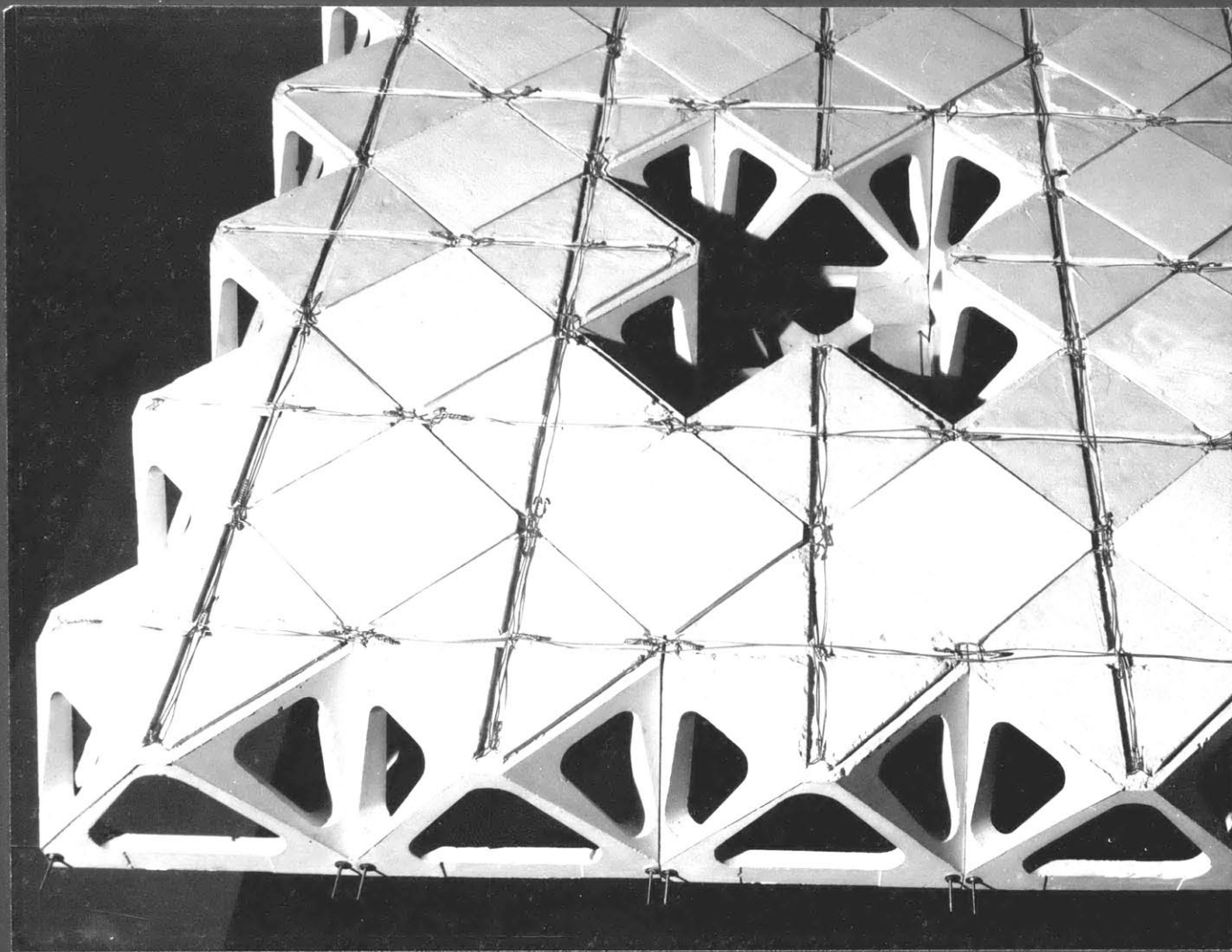

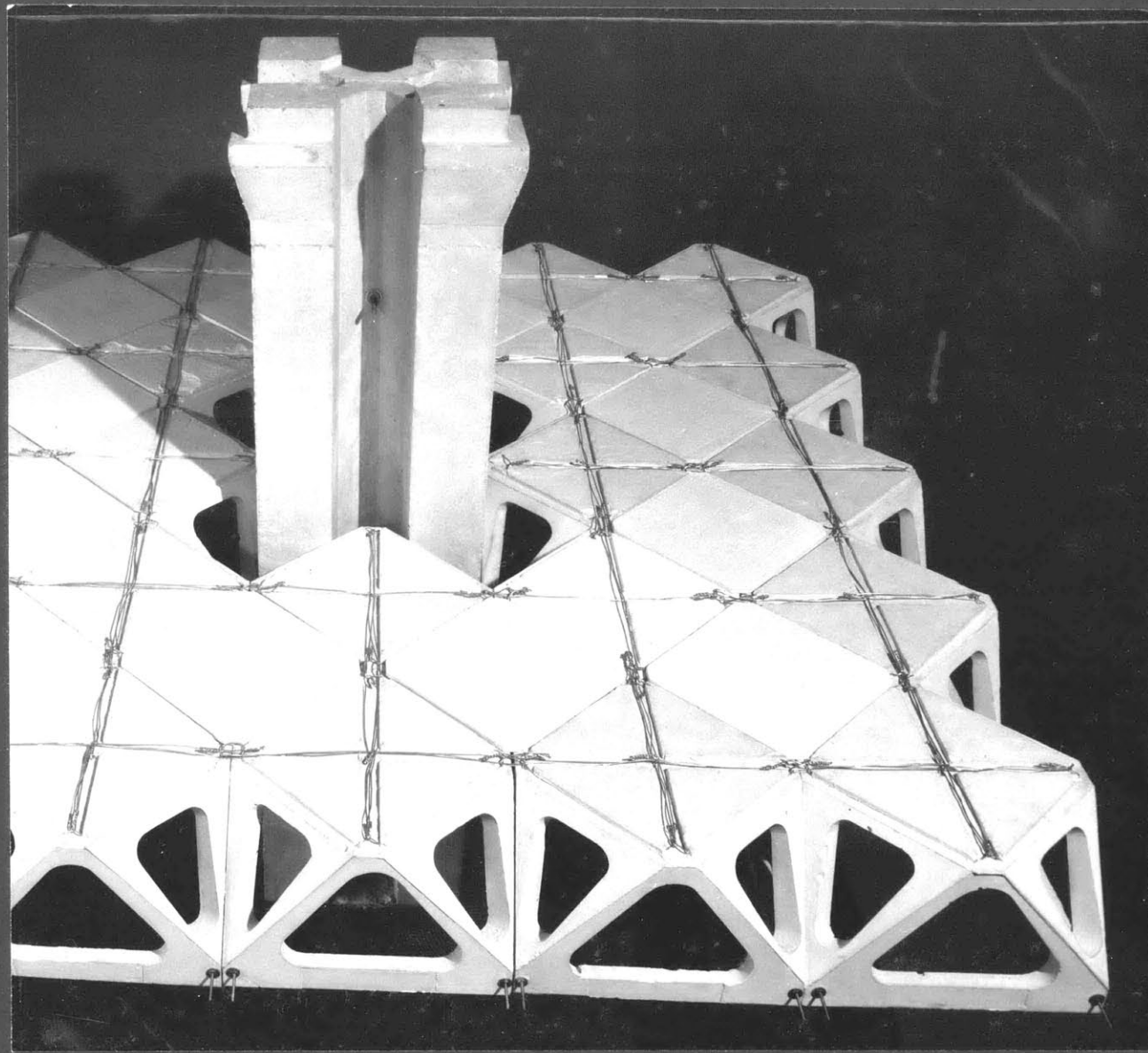

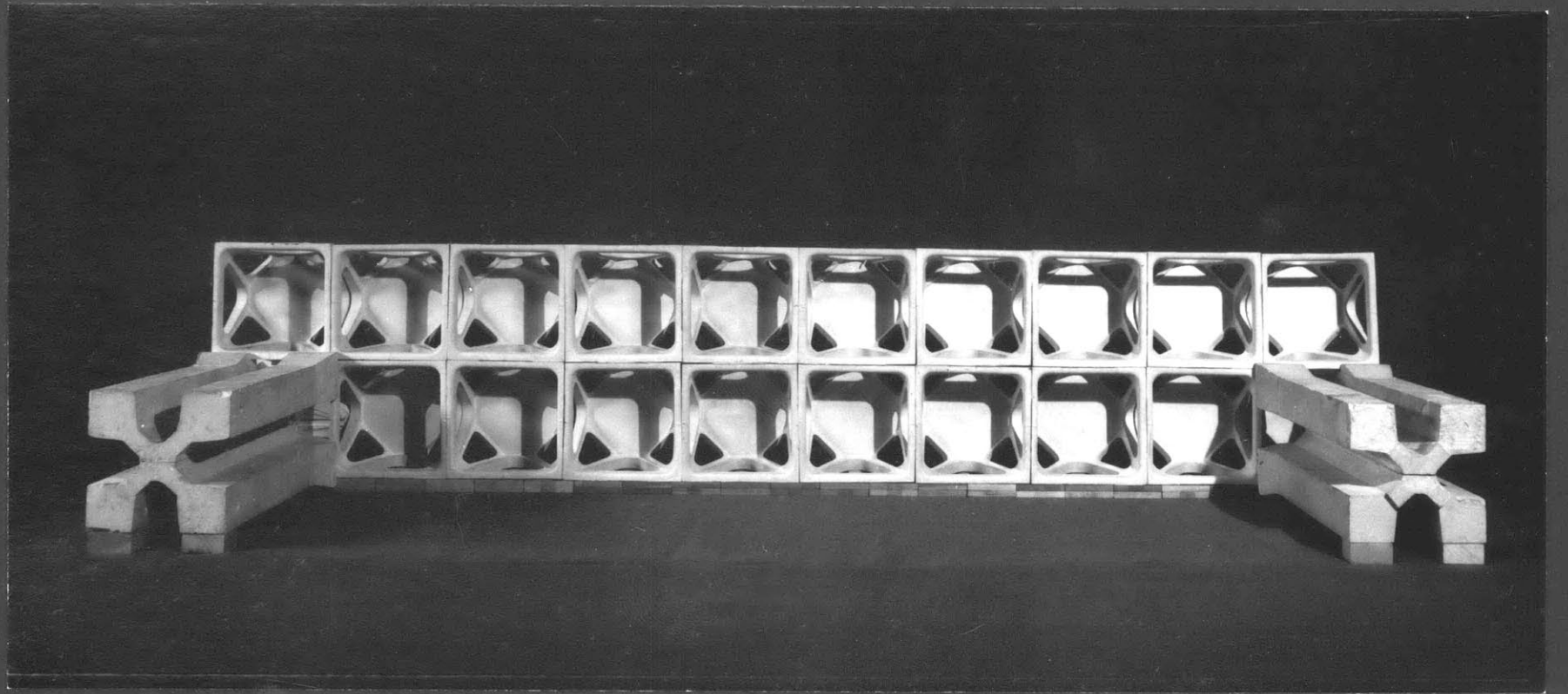

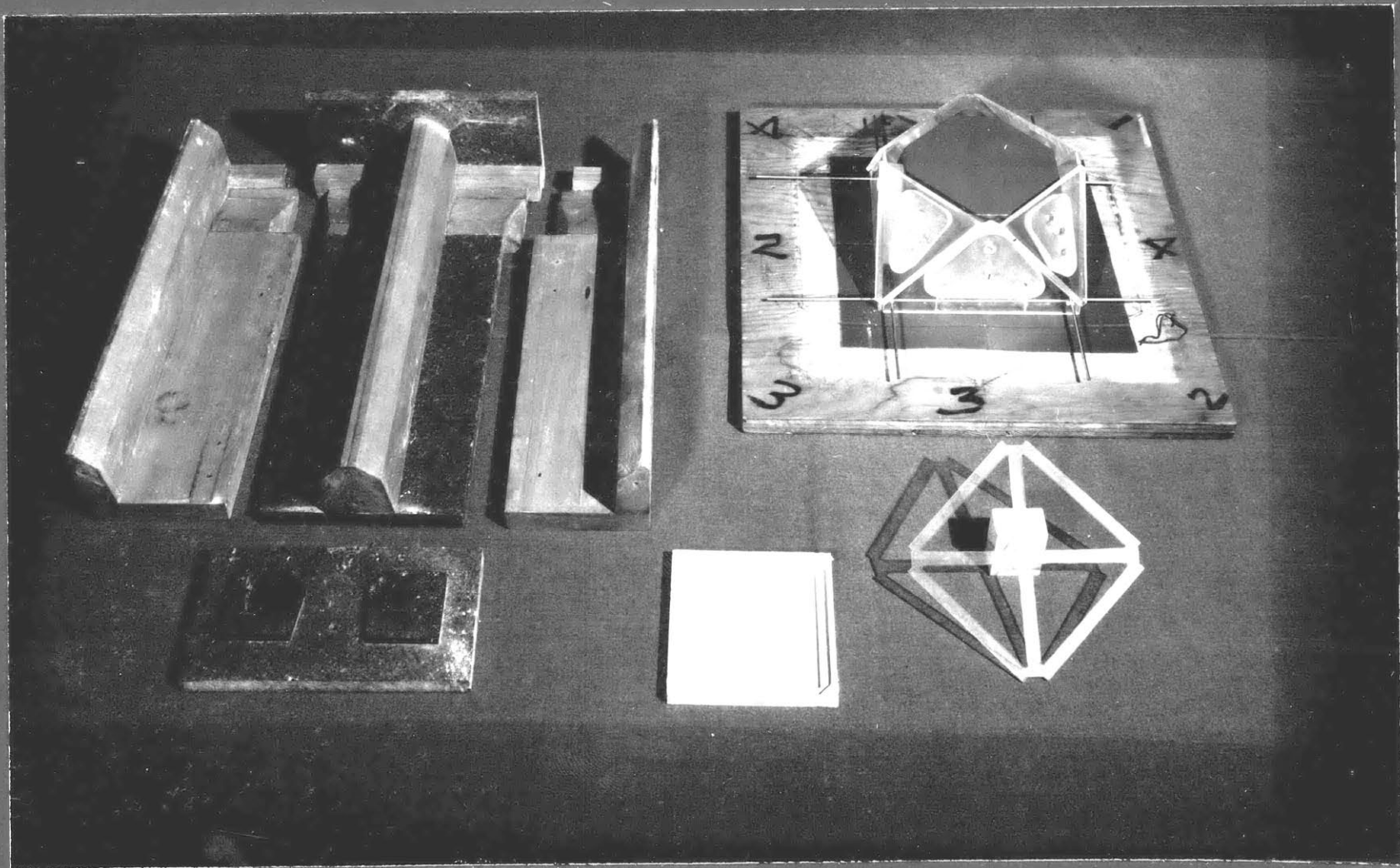

Summary

The following are the important advantages of the building system described in this report as compared with other building systems designed in the past with similar programs.

1. Assembly is accomplished with minimum use of scaffolding,
2. The floor structure is minimized to one basic unit,
3. The space truss unit, because of its geometric form (semi-cuboctahedron) is shaped in such a way that every square is surrounded by triangles only, as a result of which members are mainly under the action of axial forces which, owing to the elimination of bending moments, produces even stress distribution over the cross-sectional area of any member,
4. Space truss units can be stacked on one another to minimize shipping space,
5. Maximum efficiency of structural system is accomplished by means of four-way space frame system,
6. With one basic structural bay and its cantilever, three structural planning spaces are created, where the "internal plug-in service" can be easily incorporated,
7. A flexible mechanical distribution load is accomplished by means of two alternative supply systems,
8. The mechanical distribution and acoustics are totally integrated with an air diffusion light unit,

9. The return air system may be either in a column or in a core,
10. To achieve simplicity and economy closed plenum space is used for return air,
11. The system may grow from five stories to twenty stories high,
12. Easy access to install and repair mechanical system is provided.

There are two areas of future improvement of the building system described in this report.

First, the fire resistance technology and materials should be improved, in order to minimize material use and to permit a full utilization of strength leading to a high efficiency in the use of material. The space truss unit now weighs approximately one ton. A lower weight could obviously be an improvement, and this could be achieved if better ways are available.

Second, the present post-stressing construction methods such as pressure grouting and threading cables through units are limited to the maximum 180 feet. In planning large scale buildings with large uninterrupted floor square footage there could arise difficulty in construction.

Conclusion

The program is strictly an academic study only. This architectural study is primarily concentrated around the technological aspect of buildings. It does not include the economics, and the social aspects of urban core patterns and systems.

The result of the design proposal in this study enables us to understand the potential of a methodological organization of building systems and constructions.

Recent developments in a number of departments at M.I.T. have demonstrated the usefulness in design of interactive man-machine systems which time-shared computers, remote consoles, and graphical input-output capabilities. The building designer should use the computer as a design tool to guide his research and to supplement his ability to design.

Appendix

DESIGN CRITERIA

Lighting	70 F.C.	3 watts/sq.ft.
	100 F.C.	4.5 watts/sq.ft.
	150 F.C.	6.5 watts/sq.ft.
	200 F.C.	8.6 watts/sq.ft.

Misc. Power

Office	.5 watts/sq.ft.
Lab	1 watt/sq.ft.

People

Office or Lab,	1 person/100 sq.ft.
Assembly,	1 person/30 sq.ft.

Fume Hoods

Face Opening 4'x 2'-6" = 10 sq.ft.
10 sq.ft. x 80' face velocity = 800 CFM

Example

Lighting

$$4.5 \text{ watts/sq.ft.} \times 3.415 \text{ BTU/watt} = 15.4$$

Misc. Power

$$1 \text{ watt/sw.ft.} \times 3.415 \text{ BTU/watt} = 3.4$$

People

$$300 \text{ BTU sensible heat} \div 100 \text{ sq.ft./person} \quad \underline{3.0}$$

21.8

$$\frac{21.8 \text{ BTU/hr/sq.ft.}}{1.08 \times 20^\circ\Delta T} = 1 \text{ CFM/sq.ft.}$$

RULES-OF-THUMB FOR DIMENSIONING STRUCT. MEMBERS

TRIBUTARY AREAS (A_T) FOR VARIOUS GEOMETRIES - A_T IN FT²

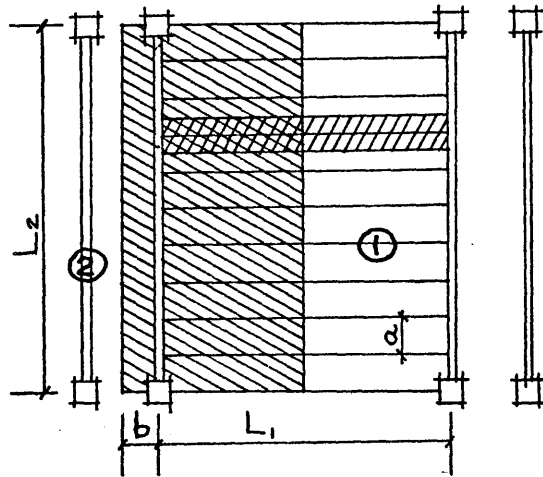

ONE WAY

$$A_{T①} = L_1 \cdot a$$

$$A_{T②} = L_2 \cdot \frac{L_1 + b}{2}$$

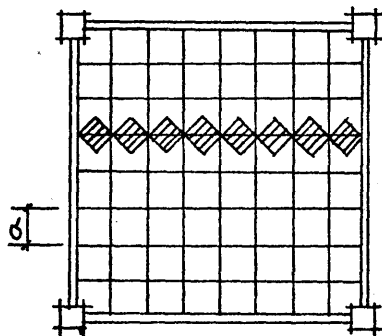

TWO WAY

INTERIOR BEAM

$$A_T = \frac{L \cdot a}{2}$$

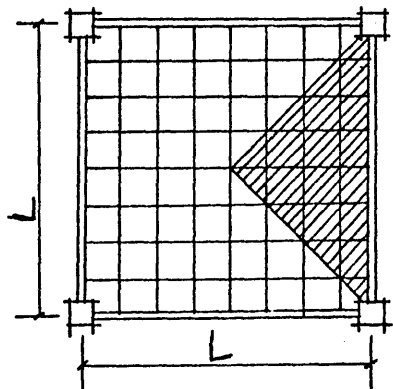

GIRDER

$$A_T = \frac{L^2}{2}$$

DIMENSIONS OF STRUCTURAL CROSS SECTIONS IN SQ. IN.
 (ASSUMING LL. & DL. = 200 LBS/SQ. FT.)

I SECTION AREAS OF THE TENSION CHORD FOR SIMPLY SUPPORTED BEAMS

① CROSS SECTIONAL AREA OF REINFORCEMENT
 (USING 30,000 LBS/IN² ALLOWABLE STRESS) --- $A_{ST30} = \frac{A_T \cdot L/h}{1000}$
 h = DEPTH OF BEAM
 L = SPAN OF BEAM

AREA OF CONCRETE COVERING REINF. STEEL --- $A_{CT} = A_{ST30} \cdot 6 = \frac{A_T \cdot L/h}{1000} \cdot 6$

② CROSS SECTIONAL AREA OF HIGH-STRENGTH CABLES FOR PRE AND POST STRESSING --- $A_{CABLE} = \frac{A_T \cdot L/h}{5000}$
 AREA OF CONCRETE COVERING CABLES --- $A_{C.CABLE} = \frac{A_T \cdot L/h}{100}$
 SECTION AREA OF COMPRESSION CHORD --- $A_{CC} = \frac{A_T \cdot L/h}{50}$

II DIAGONAL MEMBERS

INCLINATION 1:1

AREA OF STEEL IN TENSION --- $A_{ST30} = \frac{A_T}{200}$

AREA OF CONC. COVERING STEEL --- $A_{CT} = \frac{A_T}{200} \cdot 6$

AREA OF CONC. IN COMPRESSION --- $A_{CC} = \frac{A_T}{10}$

INCLINATION 1:2

 AREA OF STEEL IN TENSION --- $A_{ST30} = \frac{A_T}{200} \cdot 1.5$

AREA OF CONC. COVERING STEEL --- $A_{CT} = \frac{A_T}{200} \cdot 9$

AREA OF CONC. IN COMPRESSION --- $A_{CC} = \frac{A_T}{10} \cdot 1.5$

III AREA OF COLUMN FOR 5 STORY BLDG.

$A_{COL} (SQ. IN.) = A_T (SQ. FT.)$

STRUCTURAL CALCULATIONS: (FOR TYPICAL BAY)

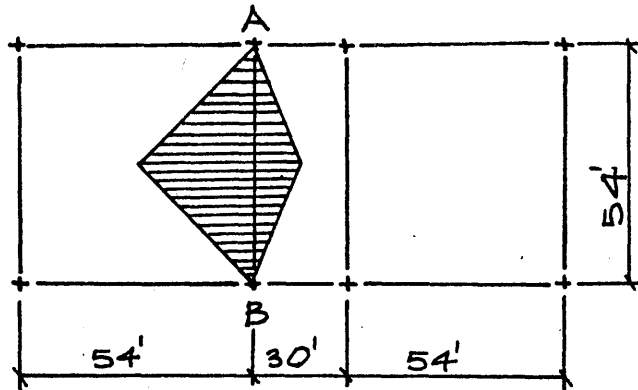

1.0 TYPICAL TRIBUTARY AREA

$$\begin{aligned}
 &= \left(\frac{1}{4}\right)(54' \cdot 54') + \left(\frac{1}{4}\right)(54' \cdot 30') \\
 &= 730 + 405 \\
 &= 1135 \text{ SQ. FT.}
 \end{aligned}$$

FOR FOUR-WAY SYSTEM

FACTOR: 0.75

$$\text{AREA} = 0.75 \cdot 1135 = 850 \text{ SQ. FT.}$$

1.1 TRIBUTARY AREA SUPPORTED BY FOUR CABLES AB

TRIBUTARY AREA PER ONE CABLE

$$\text{AREA} = \left(\frac{1}{4}\right) \cdot 850 = 212 \text{ SQ. FT.}$$

1.2 CABLE AREA

$$A_{\text{CABLE}} = \frac{A_T \cdot L/h}{5000} = \frac{212 \cdot 54/4}{5000} = \frac{.570 \text{ IN}^2}{7/8'' \text{ IN DIAMETER OF CABLE}}$$

1.3 AREA OF CONCRETE COVERING CABLES

$$A_{\text{CONC.}} = \frac{A_T \cdot L/h}{100} = \frac{212 \cdot 54/4}{100} = \frac{28.6 \text{ IN}^2}{5'' \text{ (WIDTH)} \cdot 6'' \text{ (DEPTH) MAY BE USED}}$$

1.4 SECTION AREA OF COMPRESSION CHORD

$$A_{cc} = \frac{A_T \frac{1}{4} h}{50} = \frac{212 \cdot 54 \frac{1}{4}}{50} = 57.2 \text{ IN}^2$$

1.5 DIAGONAL MEMBERS

$$A_{st30} = \frac{A_T}{200} = \frac{212}{200} = 1.06 \text{ IN}^2$$

1/4" DIAMETER STEEL BAR FOR TENSION MEMBERS

$$A_{conc} = \frac{A_T}{200} \cdot 6 = 1.06 \cdot 6 = 6.35 \text{ IN}^2$$

$$A_{cc} = \frac{A_T}{10} = \frac{212}{10} = 21.2 \text{ IN}^2$$

1.6 AREA OF COLUMN FOR 5 STORY BUILDING

$$A_T = \left(\frac{1}{4}\right)(54 \cdot 54) + 2 \left(\frac{1}{4}\right)(54 \cdot 30) + \left(\frac{1}{4}\right)(30 \cdot 30)$$

$$= 1765 \text{ IN}^2$$

$$A_{col \text{ IN}^2} = A_T \text{ (ft}^2\text{)}$$

$$A_{col} = 1765 \text{ IN}^2$$

$$= 12.2 \text{ FT}^2$$

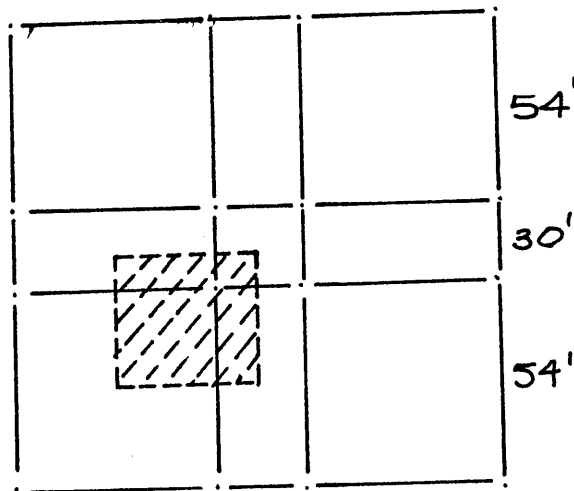

1.7 AREA OF COLUMN

FOR 20 STORIES: σ REINF. AT 2000 PSI

$$A_{col} = \frac{1}{2} [(A_T) \cdot 4] = 24.4 \text{ SQ FT.}$$

Bibliography

Borrego, John. Space Grid Structures. Master of Architecture Thesis, M.I.T., 1966.

Carrier Corporation. Handbook of Air-Conditioning System Design. New York, 1965.

Siegel, Kurt. Structure and Form in Modern Architecture. Reinhold Co., New York, 1962.

Servers, William H. Air Conditioning and Refrigeration. New York, John Wiley & Sons, 1962.

American Insurance Association. The National Building Code. New York, Chicago, and San Francisco, Engineering and Safety Department, 1967.

Westinghouse. Lighting Handbook. Bloomfield, New Jersey, Westinghouse Electric Corporation, Revised August, 1964.

Preston, H. Kent, P.E. Plumbing Practical Prestressed Concrete. New York, McGraw-Hill Book Co., Inc., 1960.

Knudsen, V. O., and C. M. Harris. Acoustical Designing in Architecture. New York, John Wiley & Sons, 1963.

Manas, Vincent T., P.E. National Plumbing Code Handbook. New York, McGraw-Hill Book Co., Inc., 1957.

Ekuan, Kenji. The Fundamental Essence of Space. The Canadian Architect, December, 1966.

Winter, George, and Wilson, A. H. Design of Concrete Structures. New York, McGraw-Hill Book Co., Inc., 1964.