

Design and Development of an Automated Pinning Machine for the Surface Mount Electronics Industry

By

Daniel J. Cook

B.Sc. Mechanical Engineering
Rensselaer Polytechnic Institute, 2009

Submitted to the department of mechanical engineering in partial fulfillment of the requirements for the degree of

MASTER OF ENGINEERING IN MANUFACTURING
AT THE
MASSACHUSETTS INSTITUTE OF TECHNOLOGY

September 2012

©Daniel J. Cook. All rights reserved.

The author hereby grants to MIT permission to reproduce and to distribute publicly paper and electronic copies of this thesis document in whole or in part in any medium now known or hereafter created.

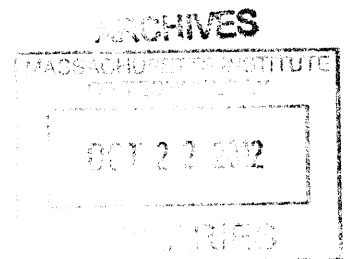

Signature of Author: _____

A handwritten signature in black ink, appearing to read "Daniel J. Cook".

Daniel J. Cook
Department of Mechanical Engineering
August 23, 2012

Certified by: _____

A handwritten signature in black ink, appearing to read "David E. Hardt".

David E. Hardt
Professor of Mechanical Engineering
Thesis Supervisor

Accepted by: _____

A handwritten signature in black ink, appearing to read "David E. Hardt".

David E. Hardt
Professor of Mechanical Engineering
Chairman, Committee for Graduate Students

Design and Development of an Automated Pinning Machine for the Surface Mount Electronics Industry

By

Daniel J. Cook

Submitted to the Department of Mechanical Engineering on 23 August, 2012,
In partial fulfillment of the requirements for the
Degree of Masters of Engineering in Manufacturing

Abstract

This thesis describes the development of a concept for a pinning process and the associated machinery to handle odd-form pins specific to a company in the surface mount electronics industry. The developed pinning machine will reduce manual labor requirements, increase flexibility over current automated systems, and allow for greater part traceability. A brief history of industrial automation is presented to establish a background of the industry, followed by a more detailed look at robotic tooling. The design of the automated pinning machine is described in detail, as well as the design methodology behind the sub-systems and components themselves. Finally, the performance of the machine is documented in a testing chapter, comparing machine performance to the original design specifications. The final pinning machine is capable of processing pins with cycle times of 850ms, and has a mean time to failure of 0.24 hours.

Thesis Supervisor: David E. Hardt

Title: Professor of Mechanical Engineering

*For my grandparents,
Nancy and Charles Entenmann*

Acknowledgements

There are a number of people I need to thank for their contributions to this thesis, both at MIT and SynQor.

Firstly, many thanks go to my teammates, Michelle Chang and Rejin Isaac. The three of us brought very different skill sets to the project, and it really fostered a creative work environment.

Professor David Hardt, our thesis advisor, was always available to give us direction when we reached a challenge that we didn't know how to overcome. Thank you for your valued input.

Our writing advisor, Jennifer Craig, was a huge help when it came to structuring this thesis, and organizing my thoughts. I'm much happier with this thesis as a result of her input.

At SynQor, I have to thank our supervisor, Len Pitzele, for sharing with us his vast knowledge and experience in manufacturing automation and system design. He went above and beyond to make sure we were not only producing something of value for SynQor, but that we were also learning (from our successes and failures) along the way.

Mike LeDuc, the machinist at SynQor, was a great source of insight when it came time to finally build our prototypes. He was always ready to tell me when I was about to do something wrong – *usually* before the fact.

Thanks go to all others at SynQor for being welcoming and helpful to the three of us.

And, of course, I wouldn't be submitting this thesis today if I didn't have the help and encouragement of my family to always push my boundaries.

Contents

1	Introduction.....	8
1.1	Motivation.....	9
1.2	Objectives.....	10
1.3	Scope.....	10
1.4	Work Distribution.....	10
2	Pinning System.....	12
2.1	Pins.....	12
2.1.1	Functionality.....	12
2.2	Existing Pinning Methods.....	14
2.2.1	Manual Pinning.....	15
2.2.2	Automated Pinning – Flexible Automation.....	17
2.2.3	Automated Pinning – Specialized Automation.....	19
2.3	Developed Solution.....	20
2.3.1	Overall Pinning Process/Final Design.....	21
2.3.1.1	Sorting.....	22
2.3.1.2	Insertion.....	23
2.3.2	System Components.....	23
3	Automation.....	25
3.1	Defining Automation.....	25
3.2	Brief History of Automation.....	26
3.3	Dynamics/Configurations.....	27
3.4	Economics of Automation.....	30
3.5	State of the Art.....	31
3.5.1	State of the Art of Machine Vision.....	31
3.5.2	Robotic Improvements.....	33
4	Robotic End Effectors.....	35
4.1	Types of End Effectors.....	35
4.1.1	Tooling.....	35
4.1.2	Part grippers.....	37
4.2	Design Considerations for Part Grippers.....	38
4.3	Applications to the Pin Insertion Process.....	40
5	Machine Design.....	42
5.1	Project Scope.....	42

5.2	Machine Specifications.....	43
5.2.1	Pin Magazine.....	44
5.2.2	Insertion Head	45
5.3	Final Design.....	47
5.3.1	Pin Magazine.....	50
5.3.2	Insertion Head	54
5.3.2.1	Chassis	55
5.3.2.2	Pin Escapement.....	56
5.3.2.3	Insertion Arm	58
6	Design Methodology.....	63
6.1	Pin Magazine	63
6.1.1	Pin Storage.....	63
6.1.1.1	Feeder Slide Dwell Time.....	64
6.1.2	Pin Feeding to Insertion Head	66
6.2	Insertion Head.....	68
6.2.1	Pin Escapement.....	68
6.2.2	Pneumatic System.....	70
6.2.3	Insertion Arm Bearing Arrangement.....	75
7	Testing.....	83
7.1	Testing Methodology	83
7.1.1	Mean Time To Failure	83
7.1.2	Cycle Time	83
7.2	Testing Results.....	84
7.2.1	Mean Time To Failure	84
7.2.2	Cycle Time	84
7.3	Failure Characterizations.....	85
7.3.1	Critical Failures	85
7.3.1.1	Failure of a Pin to Exit the Magazine.....	86
7.3.1.2	Galling Between Moving Parts	87
7.3.1.3	Double-Feeding pins.....	87
7.3.1.4	Drifting Hard Stops.....	88
7.3.2	Non-Critical Failures.....	88
8	Future Work.....	90
8.1	Magazine.....	90

8.2	Insertion Head.....	90
8.3	Overall System Future Work	91
9	Conclusions.....	93
10	Appendix	94
11	Bibliography.....	97
12	Bill of Materials	100
13	Engineering Drawings.....	102

Chapter 1. Introduction

Surface Mount Technology (SMT) is a commonly used method in the electronics industry to assemble components on a printed circuit board (PCB). SMT allows both sides of the PCB to be populated with components, as opposed to traditional through-hole technology, where the leads of electronic components are inserted and soldered into holes in the PCB, which prevents the opposite side of the PCB from being used to mount components. With SMT, the PCB can then be physically smaller than PCBs produced through traditional through-hole methods. This has led to SMT being adopted as the standard assembly method in the electronics industry.

A typical SMT assembly line is mostly automated with manual interaction limited to loading and unloading of PCBs, and setting up machines for production runs. The assembly begins with the application of solder paste using a stainless steel stencil on the regions of the board where components are to be placed. Next, a pick and place machine places components on these regions. Modern day pick and place machines are capable of placing as many as 30,000 parts per hour. The boards then pass through a reflow oven, which melts the solder paste and fuses the components to the PCB. The opposite side is populated with parts using a similar procedure.

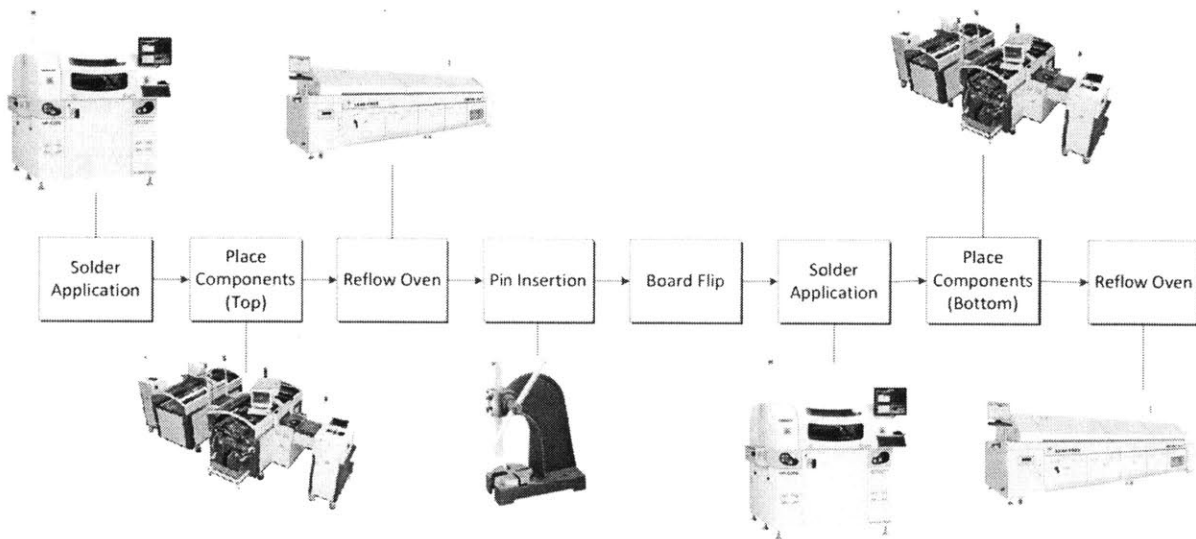

Figure 1 - SMT line process schematic

Current enters and leaves the circuit through conductive input output (I/O) pins that are pressed into holes in the PCB. The pin insertion process takes place between the top and bottom side SMT

assembly lines. These pins come in various lengths and diameters and can be inserted into the PCBs either manually or using an automated pinning machine. Figure 2 shows a commonly used pin.

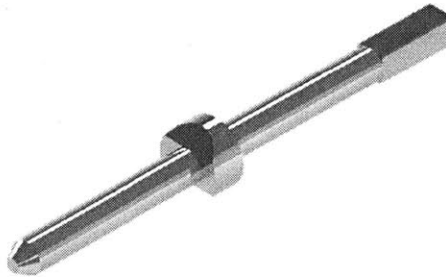
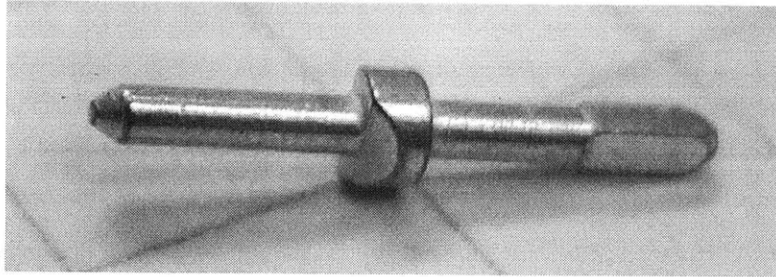

Figure 2 – Photo of typical pin in use (top); CAD rendering of pin (bottom).

1.1 Motivation

The advantages of an automated pin insertion machine are higher throughput, decreased labor requirements and higher parts traceability. Although there are numerous automated pinning machines available in the market, customizing a pinning system to a company's specific requirements can prove to be a challenging task. Machines designed for pinning may not meet the reliability and throughput requirements that the company must achieve. Some of the common problems faced are:

- Reliably sorting pins from their loose state;
- Jamming of pins
- Incorrect pin type being passed to the insertion head; and

- Correct pin types being rejected by the system.

This thesis describes efforts in re-engineering the existing pinning machine at SynQor Inc., a designer and manufacturer of power supplies located in Boxborough, MA.

1.2 Objectives

The project proposed to re-engineer a pre-existing pinning system by creating proof of concept prototypes that demonstrate a valid mechanism for PCB pinning. The prototypes must be robust, cost effective, and flexible for unknown future pin types. The key objectives were as follows:

- Develop a system which reliably sorts, orients, and inserts pins from a loose bulk state into the PCBs;
- Improve upon the current machine pinning rate of inserting 8 pins in 16 seconds, with a target cycle time of approximately 8 pins in 10 seconds;
- Produce a system that is robust while remaining easy to repair and maintain;
- Design flexibility into the machine for use with future product lines; and

1.3 Scope

The project scope encompasses building a proof of concept automated pinning machine that could efficiently insert pins of one of most widely used pin types at the company. The focus was to design a working prototype of the pinning machine, so that the company could later convert it into a production-ready machine using the same principles and mechanisms present in the prototype.

1.4 Work Distribution

Early in the design process, the conceptualized pinning system lent itself to three main sub-processes:

- Sorting the pins from a loose bulk state to an oriented state;
- Inserting the oriented pins into the PCB; and
- Developing the vision and control systems necessary for the two previous tasks.

The initial development of each process was done as a group, but further work was split among the group members. Michelle Chang worked on sorting the pins from a loose bulk state to an oriented

state [1]. Rejin Isaac developed the vision and control system deployed in the project [2]. The author of this thesis developed the pin storage and pin insertion mechanisms.

Chapter 2. Pinning System

2.1 Pins

The main focus of this project is a specialized pin which is inserted into printed circuit boards (PCB). At its most basic, a pin is a cylindrical metal part with a collar. Figure 3 illustrates the maximum dimensions and features of a pin typical to our application. In total, there are 24 different pin types of varying diameters and lengths. The three diameters pins are available in are 0.080", 0.062" and, the most commonly used, 0.040." Each of the three diameters has a selection of 8 different pin lengths depending on the application.

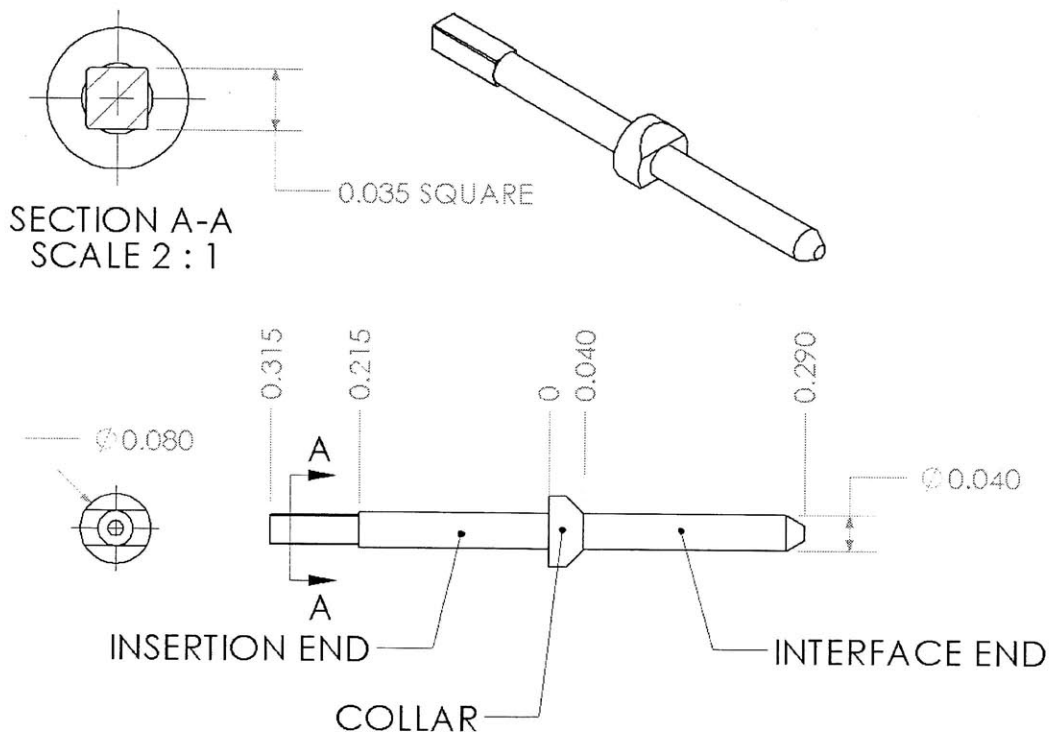

Figure 3 – Typical maximum 0.040" pin dimensions (inches)

2.1.1 Functionality

Pins are terminal components that are used to interface between the PCB and another product. They are attached to the boards with through-hole technology, that is, the pins are inserted

(pressed) into holes in the board and soldered in place (see Figure 4). By connecting via a through-hole rather than a surface-mount pad, the pins can transfer electric current through the thickness of the circuit board, useful for making interconnects on a multilayer board. [3]

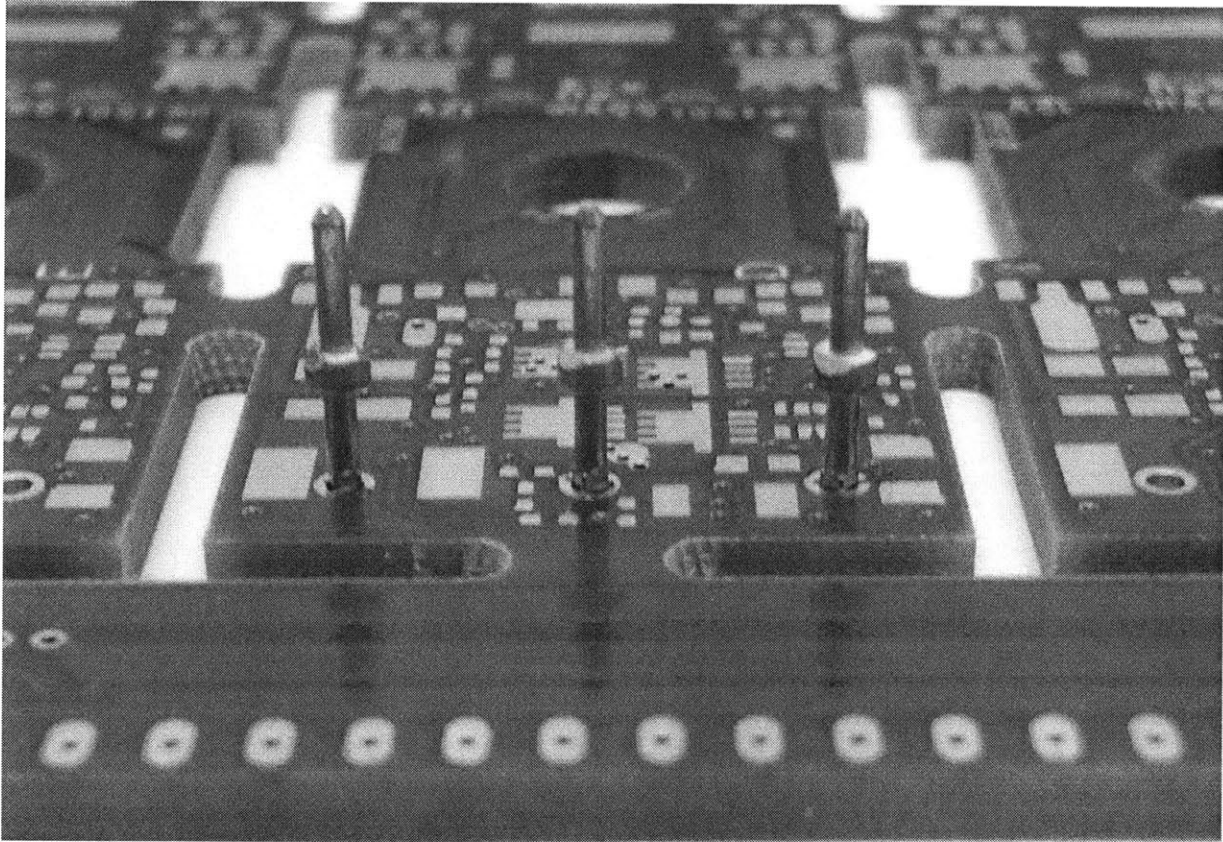

Figure 4 - Pins pressed into a PCB

These pins are used as interconnects between PCBs and other electronics external to the board they are mounted on. While one end of the pin is attached to the PCB, the other end may interface directly with the through holes of another circuit board, with receptacle terminals on another PCB, or with flexible leads. [4]

The pin is attached to the board in a two-step process. First, the pin is inserted into a PCB with an interference fit from the square or hexagonal insertion head (0.040" pins have a square insertion end, and 0.062" & 0.080" pins have a hexagonal insertion head). Second, the pin is soldered to the board. This project focused on the first part of pin attachment – the pin to board insertion process.

In addition to the features noted, the pins also have two chamfers on one side of on the pin collars, which prevent solder cavities from forming during the soldering process. The pins are lead free and plated with tin. They are manufactured on screw machines and delivered in bulk in a loose state (see Figure 5).



Figure 5 – Pins are delivered to SynQor in a loose state in boxes from the manufacturing company.

2.2 Existing Pinning Methods

There are currently three methods for pinning a PCB at SynQor. One of the methods, manual pinning, relies on an operator to manipulate the pin and insert it into the board. The other two methods are two different approaches to automating the pinning process. The three processes and the inefficiencies inherent to them are detailed in this section.

2.2.1 Manual Pinning

Pinning a board manually utilizes an arbor press with a special collet with negative pressure to retain the pin. To set up the process, the operator adjusts the depth stop on the arbor press by test inserting pins until the correct depth is achieved. Once this height is achieved and confirmed by measuring the depth, the operator locks the depth stop in place. At this point, the set up for the manual pinning process is complete.

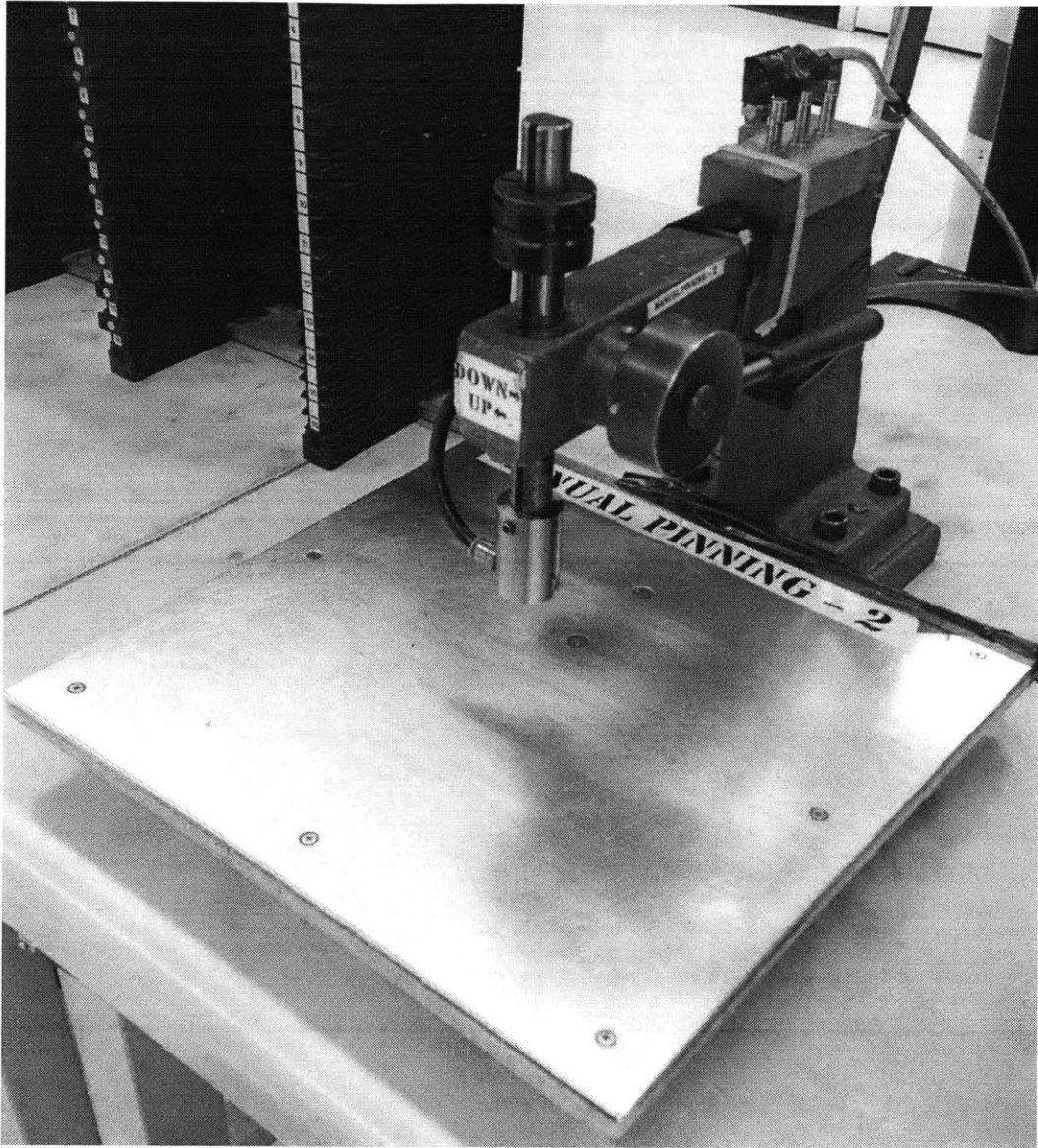

Figure 6 - Arbor Press used for manual pinning. The head of the arbor press has a collet attached to it to hold the pin with vacuum pressure.

The operator takes a pin from the box of pins, inserts the head of the pin into the collet, and then locates the circuit board under the press according to a drawing that details where each pin, and what type of pin, should be located. The board is populated with pins, and moved into a queue for the next process.

The operators scan each board into the SynQor production tracking system as they are pinning it, as well as the box that they are pulling pins from. Tracking pins in this manner provides some level of part traceability, but is prone to errors since often times there are multiple boxes of pins available for the operators to pick from.

Currently, the manual pinning process is run with two to three full time operators for two shifts per day, depending on the workload. Manual pinning is labor intensive and costly. The goal is to reduce labor requirements with the process developed herein.

2.2.2 Automated Pinning – Flexible Automation

SynQor developed a pinning machine working in conjunction with an outside company in the early 2000s. The idea was to develop a process that allowed an operator to load up to 8 different pin types in vibratory bowls and have the machine feed pins, orient them, and then send them to an insertion machine to be inserted into the board without operator intervention.

The system works by feeding the pins with vibratory bowl feeders to a conveyor. The conveyor transports the pins past a line-scan camera where an image is developed from the “slices” that the camera takes. From the image that the system builds, it analyzes the pin and determines if it is the correct pin, and if it is in the correct orientation. Downstream from the camera, an arm picks up the pin and reorients it (if necessary), then sends it through a tube by means of compressed air to the insertion robot. The robot picks up the pin and positions it at the correct point over the PCB and presses the pin to the correct depth.

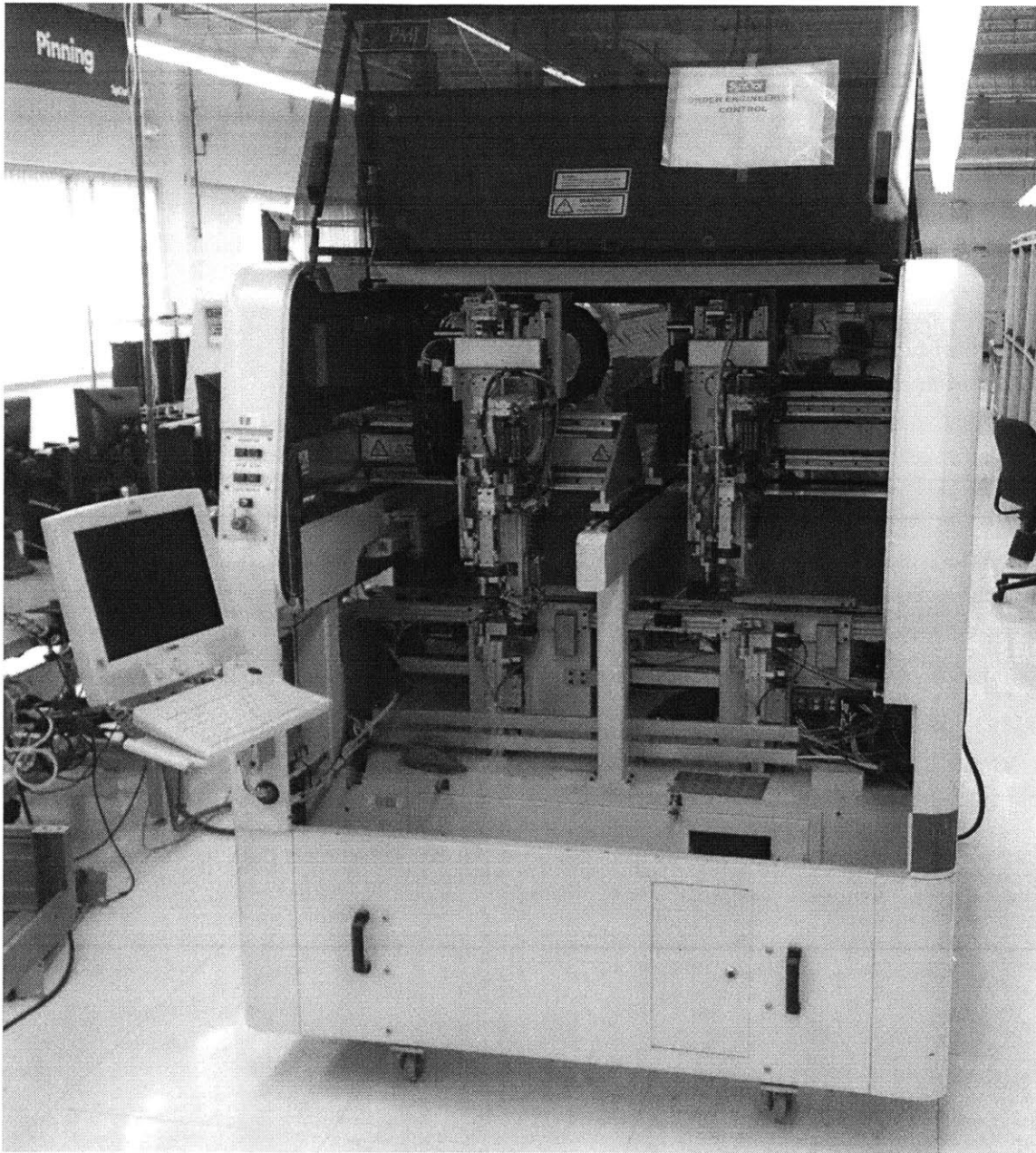

Figure 7 – Dual-gantry pinning system

This machine was used in production for approximately one year when they first purchased it, but it was prone to failures. The machine struggled to deliver pins reliably to the insertion robot. There were issues with pins jamming at certain points in the system - frequently in the tube that delivered pins from the sorting mechanism to the insertion robot. The sorting mechanism was often not able

to identify and re-orient pins fast enough to keep up with the pace set by the insertion robot. This often led to the insertion robot sitting idle while it waited for a pin.

The positioning system (a dual-gantry Cartesian robot – see section 3.3) from this machine, as well as the production system interface (barcode scanning, board programming) will be re-used in our project in its pre-existing form, with little modification.

2.2.3 Automated Pinning – Specialized Automation

Another pinning process was developed by SynQor with an outside company. This system, decidedly less “flexible” in terms of the variety of pins it can handle, as well as how it handles faults, employs vibratory bowl feeders to feed and orient the pins. The bowl feeders are customized to accept and sort different pin types. The pins are sorted mechanically by taking advantage of the non-symmetric design of the pins which allows the bowl feeders to reject pins that are not in the desired orientation.

Once the pins go through the sorting and orientation process, they line up in a queue upstream from an escapement. The escapement picks off one pin from the queue of pins and drops it down a tube to send it to the insertion head. The board is positioned under the insertion head and a pin is driven to the desired depth.

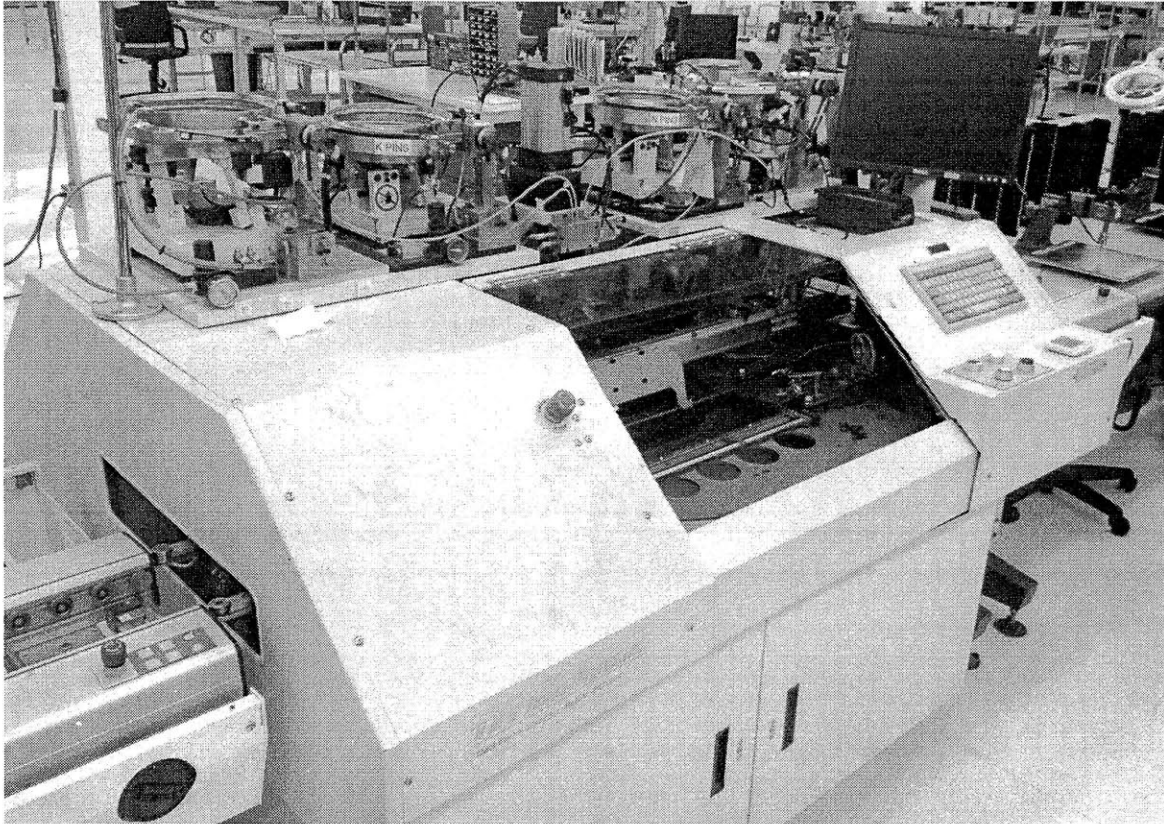

Figure 8 – The vibratory bowls of this pinning system can be seen atop the machine enclosure. These bowl feeders send pins to the insertion head inside of the machine.

This system suffers from frequent jamming in the bowl feeding/escapement area of the process. Since the bowl feeder is vibrating, some pins can ride up on each other and cause the queue to jam which requires an operator's attention to clear the jam. The positioning system in this machine has very little in terms of feedback to know if it has pressed a pin correctly.

2.3 Developed Solution

The team has developed a pinning process that accepts pins in bulk (loose) then sorts and transports them to an insertion head that orients the pins for insertion into a PCB. The processes of sorting and insertion have been decoupled by means of a "pin magazine" that stores pins between the sorting and insertion process. A systems level overview of the process is given in this section.

2.3.1 Overall Pinning Process/Final Design

The pinning process consists of two major sub-processes: sorting and insertion. The two processes were run in series in past attempts to automate pinning, which resulted in the sorting process holding up the insertion process quite often due to jams or other faults. The decision was made to “decouple” these two processes in our approach in order to be able to run the processes in parallel without running into any issues where one processes causes the other to slow or stop.

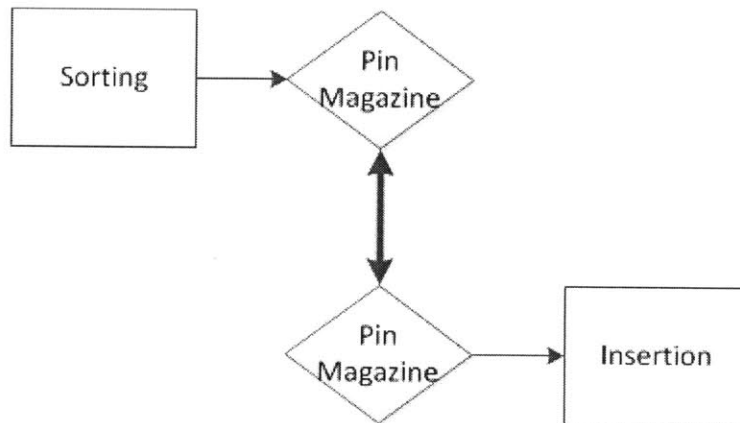

Figure 9 - Pinning Process Diagram

The system was decoupled in between the sorting and insertion sub-processes (see Figure 9) by designing a magazine to hold a determined quantity of pins that would act as the interface between the sorting process and the insertion process.

A high-level overview of the developed pinning processes is shown in Figure 10. Figure 11 shows the actual magazine used to interface between the two sub-processes. Sections 2.3.1.1 and 2.3.1.2 describe, in more detail, the sub-processes of sorting and insertion.

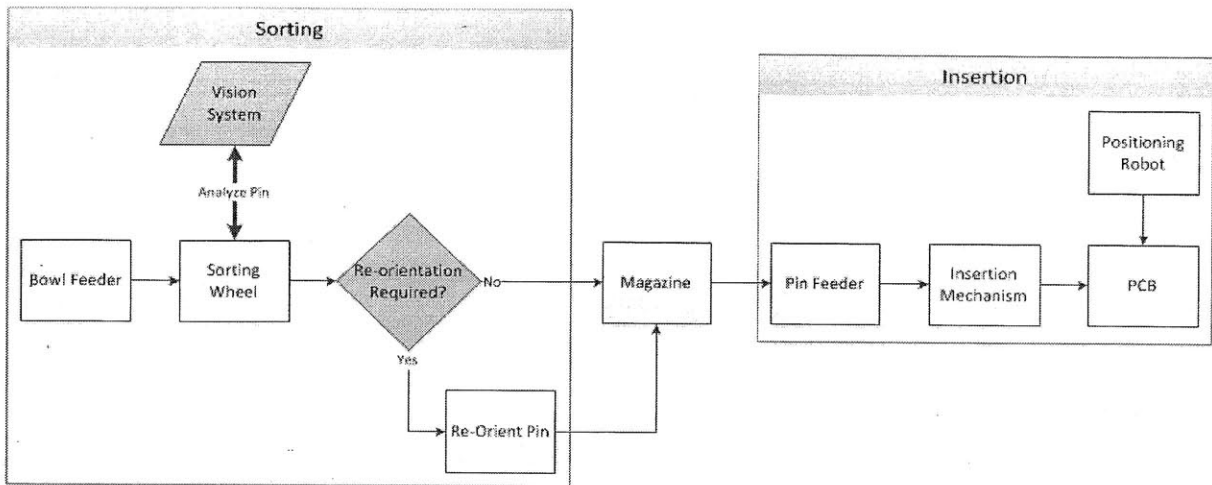

Figure 10 – Developed pinning process showing the breakdown into the sorting and insertion sub-processes.

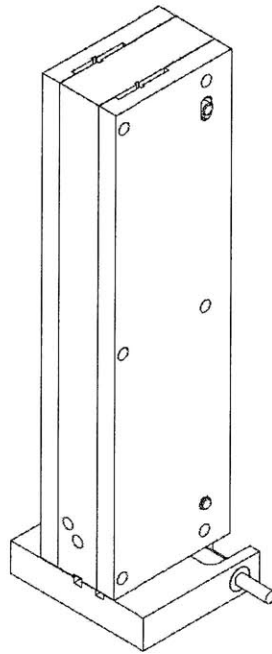

Figure 11 - Magazine used to interface between sorting and insertion process

2.3.1.1 Sorting

The process of sorting pins brings the pins from the loose state that in which they are delivered to SynQor and aligns them in the pin magazine. The sorting process utilizes vibratory bowl feeders to “singulate” the pins, and then transports them to a rotating wheel that grips the pins and brings

them in front of a camera. [1] The camera and the accompanying vision system analyze the pin and determine if it is in the correct orientation and if it is the correct pin. After the camera stage, the pin either is sent directly to the magazine if it is in the correct orientation, or it gets sent to a reorientation stage before being sent to the magazine. [2] Incorrect or damaged pins can be ejected into a waste bin at the last station on the wheel.

The sorting process is something that will be done away from of the production floor, likely in the stockroom. When pins arrive at SynQor, operators will run them through the sorting machine to populate the magazine so the magazines are ready for the production floor.

2.3.1.2 Insertion

Once the pins are sorted into a magazine, the insertion process can begin. The insertion machine will consist of two gantry-style Cartesian (see section 3.3) positioning robots. Both robots will carry insertion mechanisms. In all, one gantry will have an insertion mechanism for 0.040" diameter pins and 0.062" diameter pins, and the other will have a mechanism for 0.080" diameter pins and an additional mechanism for 0.040" diameter pins. The 0.040" pins are the highest volume pins run at SynQor, so there are two insertion heads (one on each gantry) to handle them so the workload can be balanced between the two gantries.

The insertion mechanism utilizes the part feeder integrated into the magazine to pull pins off of the bottom of the stacks and shuttle them to the eject port of the magazine. Once a pin has been shuttled to the eject port, it is sent to an insertion tube that rotates to orient the pin vertically. From here, the positioning gantry will locate the pin over the correct hole on the board and proceed to drive the pin down to the correct insertion depth.

The process will repeat until a magazine is depleted, or a new pin type is required for the board. In either case, the positioning robot can automatically unload an empty or un-needed magazine, and load a new one from a magazine storage rack located within the positioning robot's work envelope.

2.3.2 System Components

There are a number of features already implemented in the positioning system that have been developed prior to the start of this project at SynQor. We have re-used a number of these features as part of the pinning process.

The positioning system has the ability to scan the barcode located on each PCB to determine the correct part program to run for that particular board. This allows the machine to change product assemblies without operator intervention since multiple pin types can be loaded into the magazine rack.

A product-programming interface has also been developed to allow engineers to easily program new PCBs. This makes the pinning machine very flexible when introducing new products to the assembly line.

Chapter 3. Automation

The transition to automated assembly processes from manual processes has been the focus of a number of companies that perform repetitive, semi-skilled assembly tasks to build a product. This is especially true in high-wage regions. The pinning system discussed in this thesis is a good example of the justification for automation, as well as the development process to design an automation process and the accompanying equipment.

As such, it is important to have an understanding of how industrial automation came to be what it is today, and where the current focus is on advancing the field. This section aims to give the reader an overview of automation to set up the context for the process and equipment design discussed later on.

3.1 Defining Automation

At its most basic, automation can be defined as the use of machines that make a manufacturing process more efficient. The machines combine operations or have skills that are not easily acquired by a human workforce. But automation is not simply making a single process automatic; automation is the automatic handling and continuous processing of a machine, made possible with computer control. Automation processes can be considered part of the more general category of computer integrated manufacturing (CIM). [5]

It is important to differentiate automation from mechanization. Mechanization is doing work with machines. That is, operators use machinery to assist them in completing the bulk of their work. Automation reduces the human physical labor component by making much of the work automatic, controlled by computer technology. Automation operators serve a supervisory role over the automation machinery, as opposed to direct interaction with the machine as it performs its assigned task. [6]

Automation is characterized by the use of electromechanical devices such as motors, servos, hydraulic and pneumatic systems; an increase in the productivity of a given process; improved precision and reproducibility; and a decreased labor force in purely physical work.

3.2 Brief History of Automation

The advent of automation as we have defined it came hand in hand with the development of the more complex control systems, chiefly through advances in digital computing. The term automation itself was first used at the Ford Motor Company in 1945 to describe the combination of *automatic handling* and *continuous processing* in machines. [5]

The roots of automation can be traced to the electrification of factories. As it became possible to provide machines with electric motors, many already mechanized processes were combined in machines, and factories were able to implement “continuous-flow” mass production. These machines were all tooled specifically for their tasks through use of cams. The need for more flexible and sophisticated machine control became evident. Numerical control (NC) grew from this need. [7]

Numerical control is what drives much of modern precision machining. This positioning control is the technology behind the CNC (computer numerical control) machines that are viewed as a trademark of automation.

Early forms of machine control included cams and tracing machines, but these methods were not abstractly programmable. The development of the servomechanism and the subsequent selsyn (basically two servos together) meant it was possible to have highly accurate measurement information. The idea of combining this positioning system with a numerical calculator was first brought together by John T. Parsons in the 1949, with punch card readings as the calculator. [7]

The first working NC machine was developed at MIT in 1952 – a complex design involving a punch tape input, relay-based hardware registers, and many encoders and moving parts. The following decade showed many improvements to CNC systems, but it was not until the proliferation of minicomputers in the 1960s that the use of CNC machines became widespread. [7]

This positioning control technology has had usage beyond the field of machine tools. The precision positioning systems developed for machining have been extended to control of autonomous robots, many in the service of factory automation. The first such robot was the Unimate, used in a General Motors plant in 1961. The robot moved die castings and did welding, jobs considered extremely dangerous for human laborers. The trend in automation has continued today, with many robots doing the duties that humans cannot or would not want to perform. [7]

3.3 Dynamics/Configurations

There are a number of different configurations of industrial robots, each suited for different tasks. Each robot is a combination of different types of linear or rotational joints that can be manipulated in order to reach the desired position. Common configurations include the SCARA robot (Figure 12), typically used for simple pick-and-place type operations, Articulated robot (Figure 13), which has the dexterity and similar joint structure to a human arm, and the Cartesian coordinate robot (Figure 14), which is often seen in a gantry configuration [8]. Each robot has a characteristic work envelope that represents the volume that the robot can reach with its end effector.

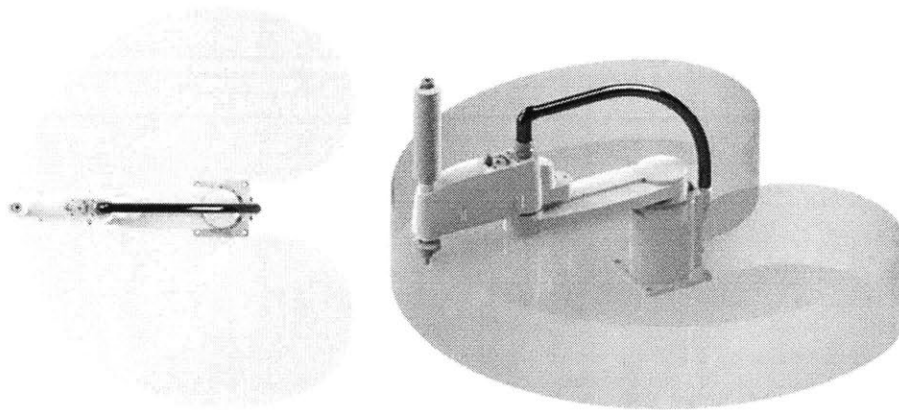

Figure 12 - Typical SCARA robot with work envelope shaded in grey [9]

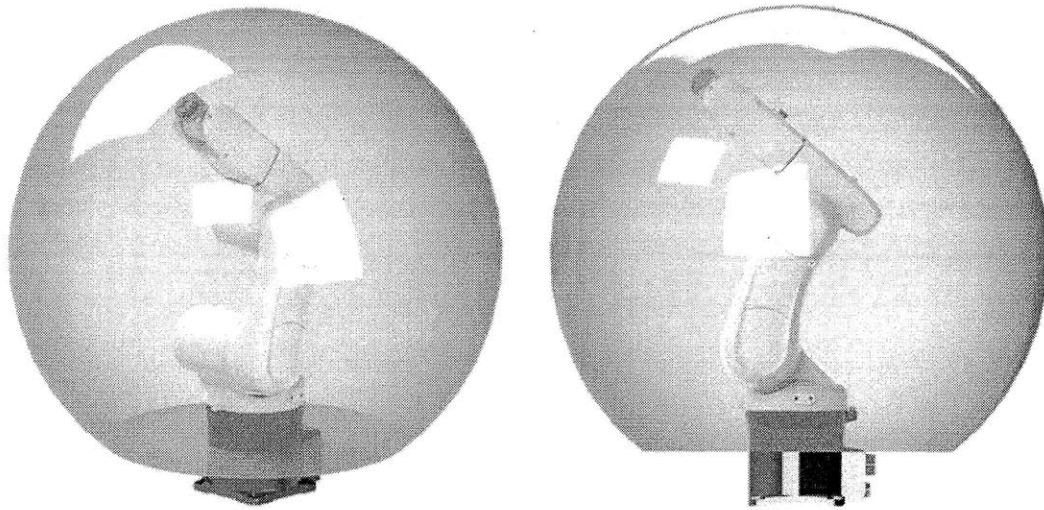

Figure 13 - Typical articulated arm robot with work envelope shaded in grey [10]

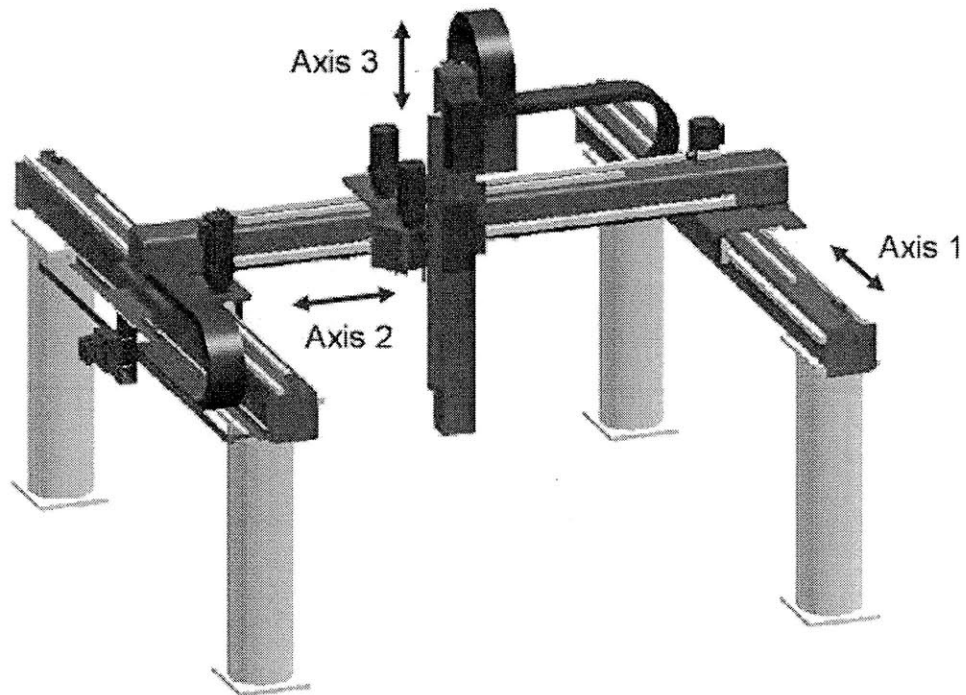

Figure 14 - Typical gantry robot [11]

The gantry (Cartesian) robot configuration used at SynQor provides a robust structure to position objects in 3D space. Unlike the other two configurations shown (SCARA and articulated arm), the

gantry configuration's axes are well supported on both ends, and do not have any cantilevered joints or frame members. Well supported joints and frame members deflect less under load, which increases the positioning accuracy of the robot.

A robot has three main coordinate systems which represent its work envelope. These coordinate systems are [12]:

- Joint Coordinates: coordinates that store the exact position of each joint in the robot to reach the desired end effector position. These coordinates are stored as positions of each joint relative to a local reference frame.
- World Coordinates: describe the position of the end effector relative to a fixed coordinate frame attached to the ground. In some cases, multiple joint orientations might satisfy the desired world coordinate position.
- Tool Coordinates: a coordinate frame is fixed to the center point of the tool on the robot. Using the tool coordinates, the robot can be programmed incrementally, without dealing with the kinematics of the robot itself since all motions are relative to the tool.

Robots can be programmed in a variety of manners. On-line programming involves programming the robot directly, which often requires taking the robot out of the production process. Off-line programming, however, utilizes computer simulation or a physical model of the robot to program the desired motions. Once the program has been generated off-line, it can be uploaded to the robot on the production line, which minimizes downtime compared to on-line methods.

Programming the motion of the robot can be accomplished in a number of ways. Text based programming methods with proprietary languages such as AIM, or V+, as well as general motion control languages that are based on Visual Basic or C can program precise motions of the robot, as well as take advantage of conditionals and loops within the program. Physical programming methods include teaching the robot points by physically moving the end effector to the desired position, then recording the sequence of points; as well as playback programming which involves teaching the robot the path it should follow between points to have more control than point to point motions.

The tool on a robot is often used to hold a part, or to hold a tool being used in a production process. Robots that hold a part often have some type of gripping mechanism as an end effector. The

gripping mechanism can physically grip the part with pneumatic or electric actuation, or it can hold the part via vacuum, or magnetics. Robots that hold a tool used in a production process will often have specialized end effectors to accommodate that tool and the accessories that go along with it. [12] [8]

3.4 Economics of Automation

With the increasing cost of labor in developed countries, automation has gotten a lot more attention from manufacturing companies that wish to continue manufacturing in high-wage environments. Additionally, with the increasing cost of labor, the price of industrial automation (i.e. robotics) has been decreasing steadily.

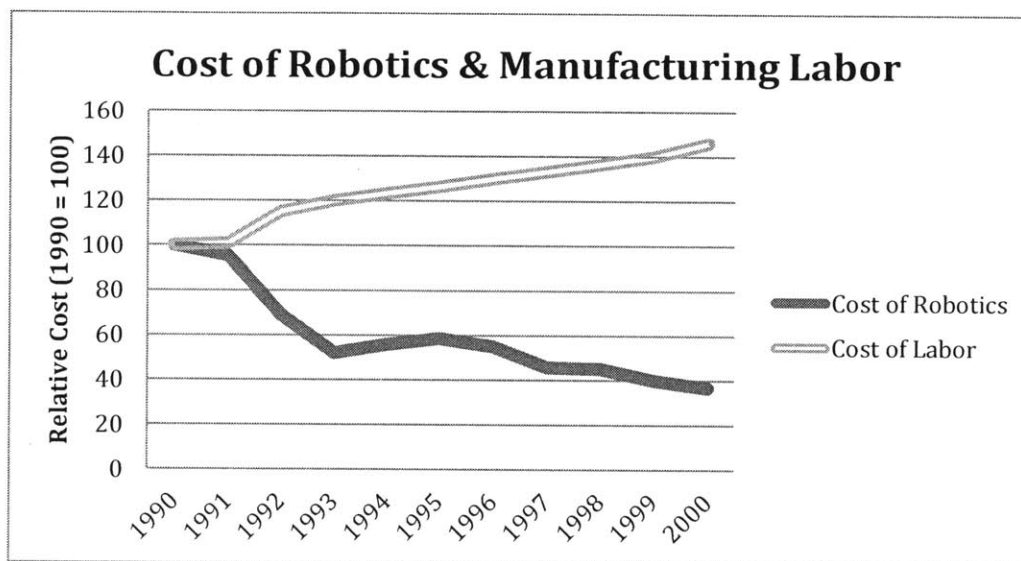

Figure 15 - Cost of robotics versus manufacturing labor [13]

In addition to the financial reasons to use automation, automation can also relieve humans from performing dangerous, hazardous, or menial tasks that are not well suited for humans to perform. Tasks that involve hazardous chemicals or materials, are performed in clean-room environments, or operate in hard-to-reach places are particularly well suited for robotics.

3.5 State of the Art

Current automation research focuses on two main areas:

- Increasing the “intelligence” of robotics through machine learning and vision systems, and
- Increasing the speed and accuracy of existing robotic systems.

3.5.1 State of the Art of Machine Vision

Machine vision has revolutionized the field of manufacturing automation by decreasing the time required for processes like inspection, counting, gauging, defect detection, thereby reducing labor requirements significantly. The advantages lie in the fact that these processes are carried out with more precision, have become faster and more reliable. Industrial machine vision systems are deployed in almost all industries like semiconductors, electronics, automotive, pharmaceutical and food packaging.

Cameras used in present day vision systems are based on Gigabit Ethernet (GigE) vision interface standard that allows data transfer rates up to 1000 Mbit/s [14]. Acquisition speed is an important parameter that defines how fast the system can capture and process images. Today, the fastest systems in the world can process up to 500 frames per second [15]. On the other hand, the size of the camera and the on board processor has decreased. The smallest camera available in the market is 30mm X 30mm X 60mm [16]. It must be noted that the processor is also embedded inside this tiny camera, making it an efficient inspection system where space is a constraint.

Along with the hardware, a lot of development has taken place in vision software to enhance image-processing capabilities, capture more intricate details of the image and provide better results.

Multi-core processors significantly reduce the processing speed and also enable controlling of up to 8 cameras simultaneously [17]. Some of these processors have additional features that can handle I/O from various systems, thereby eliminating the need for a separate PLC [18].

Features like pattern matching and edge detection have been the most commonly used features in machine vision systems. But in recent years, developments in computer algorithms and processing speeds have facilitated the introduction of newer features for image editing and processing.

Present day vision systems are not just cameras connected to a powerful processor, but also possess various sensors needed in manufacturing automation. One of the most commonly used sensors in industrial automation is the photoelectric sensor. All-in-one industrial inspection systems with embedded photoelectric sensors, camera, lighting and optics capable of inspecting up to 6,000 parts per minute are revolutionizing the world of manufacturing [19]. These low form factor inspection systems eliminate the need for expensive fixturing and simplify the overall system design. Most vision systems have a fan less design making them conducive to be used in clean room environments [17].

Systems with network protocols like RS-232, RS-485, and Ethernet built on them enable multiple systems to be controlled all at once via a LAN or VPN connection. Additionally, some software also provides web based monitoring of the production process, thereby reducing manual interference to the bare minimum [20]. All this makes the remote management of systems and generation of production reports very easy to achieve.

Machine vision is being integrated with robots to help them make judgments on the basis of what they 'see'. Machine vision based robots are being used in solar cell manufacturing to enhance the throughput and quality [20]. Most components used in solar cells are delicate and small, and require complex assembly. Physical tracking through conveyor encoders require additional tooling and fixtures, which can be eliminated by vision based inspection, thereby bringing considerable savings.

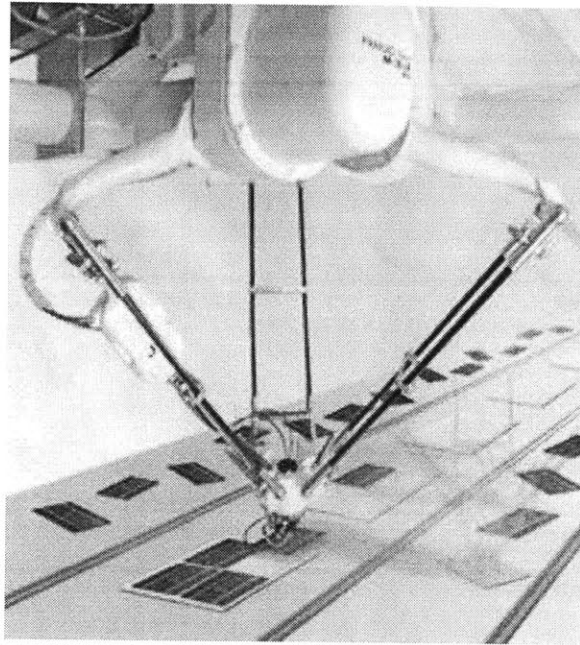

Figure 16 - Parallel configuration robot used in solar cell manufacturing [21]

The industry is slowly moving towards 3D machine vision. 3D vision helps in capturing details about the depth of the object [22]. This is especially used in semiconductor and food industries, where thickness of the object plays an important role and also in inspection of molded parts to look for defects.

In this age of economic sluggishness, as manufacturers try to keep manufacturing competitive despite increasing labor prices and competition from cheaper markets, machine vision based manufacturing automation helps bring in cost effectiveness by reducing both labor and footprint.

3.5.2 Robotic Improvements

The speed and accuracy of a robot is a factor of the structural design of the links between the different joints, the power that the joint actuators can provide, and the resolution to which the joints can be controlled.

Currently, the fastest robot on the market is the Adept Quattro robot, which has a parallel configuration of four arms (see Figure 17). The Quattro has a payload capacity of 6kg, a maximum speed of 10m/s, and a repeatability of +/- 0.1mm.

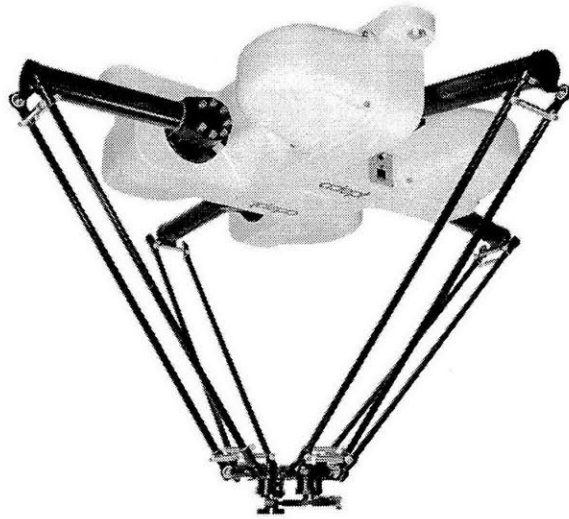

Figure 17 - Adept Quattro parallel configuration robot [23]

Chapter 4. Robotic End Effectors

In order for robots to perform the task they're programmed to do, they need special end effectors affixed to them. These end effectors, often referred to as "part grippers," or "tooling," can take a variety of form factors depending on the task at hand. End effectors are typically attached to the robot's "wrist" – the end of the kinematic chain formed by all of the robot's links and joints. [8] Robots designed to perform an operation such as welding or adhering will have an end effector that includes the tool to perform that operation as well as a method for feeding the consumed material (i.e. glue, welding material) to that tool. Other robots designed for mechanical assembly of parts will have end effectors designed to grip the parts so the robot can pick it up and manipulate it to the correct location.

The insertion head designed for the pinning machine is a form of an end effector in that it manipulates a part to the proper orientation, and is then translated by the robot to the desired position. Common end effectors are discussed in this chapter, with a focus on design types particularly applicable to the pin insertion process.

4.1 Types of End Effectors

The two categories of end effectors are tooling and part grippers. These parts are often highly customized in order to accomplish the task the robot is assigned to perform.

4.1.1 Tooling

Robots require customized tools in order to perform an operation on a work piece. These tools can include powered screwdrivers, welding guns, and de-burring tools (see Figure 18).

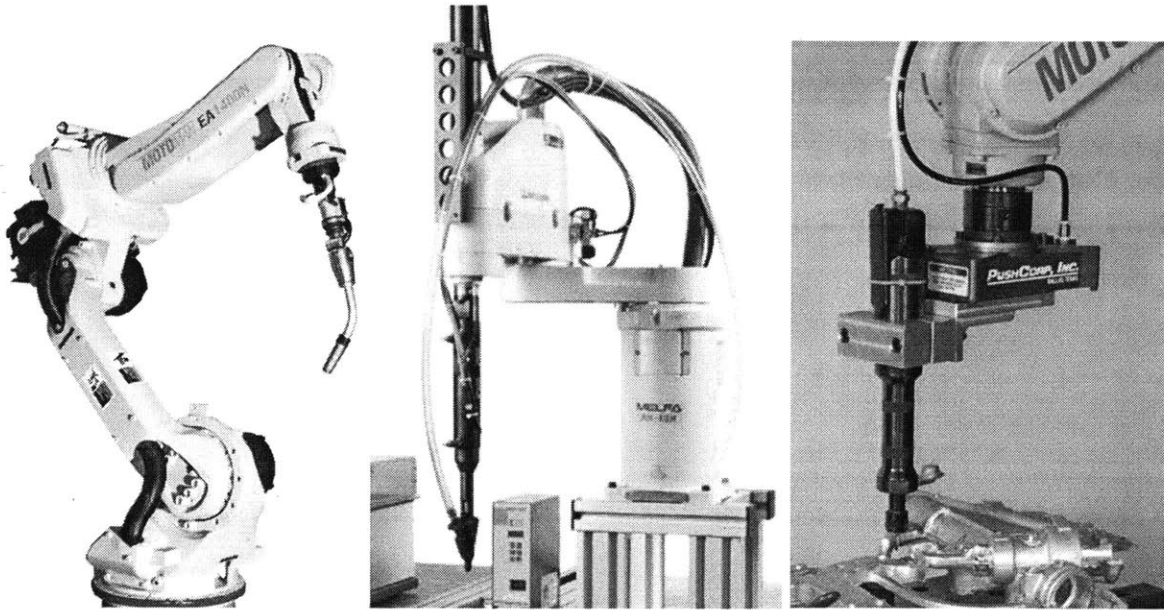

Figure 18 - Articulated arm robot with welding tool (left) [24]; SCARA robot with automatic screwdriver (middle) [25]; Articulated arm robot with de-burring tool (right) [26]

A robot is responsible for moving the tool relative to the work piece in a predetermined path. Often, the robot will also control the operation of the tool by sending signals to control the action of the tool. Parameters such as turning the tool on or off, dispensing material, or controlling the rotation speed and direction are common features for the robot to control.

Tooling can be designed so a robot can change tools during its programmed cycle. Situations where a robot needs a different size tool bit or a different tool altogether can be accompanied by designing a quick-change coupling between the robot and the tool. A “tool change” can be programmed into the robot’s work cycle to allow it to automatically set the current tool in the corresponding tool holder (usually fixed in space) and to move to another tool holder to pick up a new tool – all without operator intervention. Switching tools rather than trying to design one tool to perform all the operations that the robot is required to do reduces the total mass that the robot must carry around when it’s making its movements on its programmed path. Reducing the mass that the robot must carry around increases the speed at which the robot can travel between points.

4.1.2 Part grippers

Part grippers, unlike tooling, are designed to hold the work piece in order to transport it to a new location, or to hold it while an operation is being performed to it. Grippers can take many forms including the following:

- Mechanical grippers,
- Pneumatic grippers,
- Magnetic grippers, and
- Others, such as cryogenic grippers, simple hooks, and adhesive grippers.

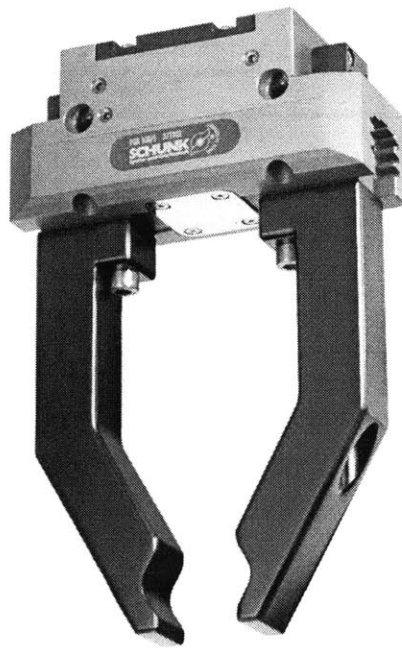

Figure 19 - Mechanical grippers [27]

Part grippers often perform assembly tasks where they must pick up the work piece from a station (sometimes on a moving conveyor, or a pallet) and attach it to the assembly at another location. The shape, weight, and material of the object being handled, as well as the required re-orientation movements in order to assemble the part all have an effect on how the gripper must be designed.

Simple mechanical grippers (Figure 19) can generally be found as standard components sold by companies that design and manufacture robotics. But, more complex grippers to handle uniquely shaped or fragile parts are usually custom designed for the application.

Grippers can be designed to include various sensors to protect the robot and the work piece it is handling. Often, the robot is programmed to sense if a part is present in the grippers, and also to monitor the amount of force being applied to the part.

4.2 Design Considerations for Part Grippers

Objects that are of a common shape (cube, sphere, or other simple polygonal shapes) can often be handled with off-the-shelf mechanical grippers and generally require little customization in order to effectively transport the part.

When unique parts must be handled, customized grippers must be designed for that specific part. Part characteristics that make a part unique include:

- fragility,
- mass,
- coefficient of friction,
- size, and
- Part presentation.

The accuracy and speed at which parts must be transported dictates most of the design process when designing part grippers. The design engineer must make a tradeoff between gripper stiffness and gripper weight to satisfy the requirements; grippers that deflect a considerable amount when carrying a payload, or during acceleration, will reduce the accuracy of the part placement because the robot usually does not account for this deflection. However, designing a gripper too robust will increase the mass of the gripper itself, and will reduce the payload capacity of the robot as well as the maximum speed at which it can travel. The robot must be able to carry the mass of the part gripper and the part together, since these two objects travel together on the robot's wrist.

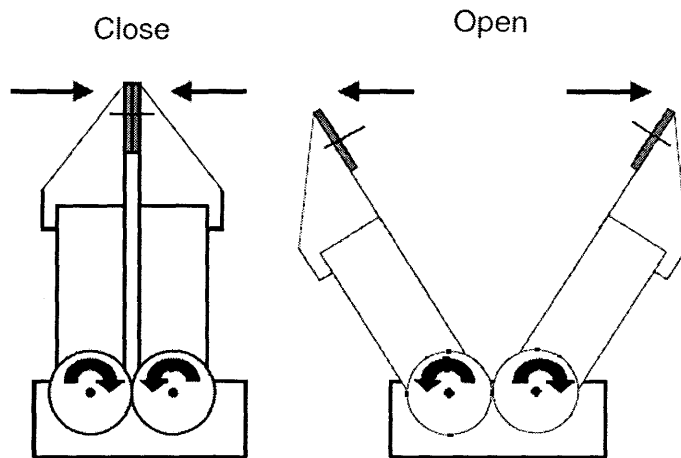

Figure 20 - Mechanical grippers showing the open and closed state [28]

Mechanical part grippers (such as the jaws shown in Figure 19 and Figure 20) must provide sufficient clamping force to hold the part via friction between the jaws and the surface of the part. In pneumatically actuated grippers, this friction is controlled by the amount of pressure used to clamp the jaws shut. The friction force generated must be greater (by a certain safety factor) than the force due to gravity, and the force due to accelerations generated by the robot combined. Part fragility must be considered when designing the gripping pressure to be used. In certain cases with particularly fragile work pieces that are to be gripped by mechanical grippers, different materials may be used to increase the coefficient of friction between the part and the gripper jaw. Lifting glass objects with aluminum grippers might not provide enough friction to securely hold the part since the coefficient of friction between glass and most metals is 0.20. In order to increase friction without increasing the clamping pressure, the design engineer can add rubber pads to the part grippers which have a coefficient of friction of 0.90 – thus providing more friction force from the same clamping pressure. [28]

In addition to considerations about the part itself, attention must be paid to the manner in which parts are presented to the gripper. There are a number of different ways parts are commonly presented for manipulation by a robot. Some common presentation methods include:

- Parts fed to a robot's work envelope by means of a conveyor.
- Parts presented on a pallet which is manually or automatically loaded to the work envelope.

- Parts are “fed” to the gripper without requiring the robot to move to a location to pick up the part. This is a common method used for lightweight parts that can be fed down a tube with air pressure.

In the first two cases where the robot must move to a location to pick up a part (usually from an array of parts), the amount of space between parts and the orientation of the parts must be considered. Parts that are spaced closely together need grippers that can fit between the gap between the two parts in order to successfully pick up and manipulate the part without interfering with neighboring parts.

The orientation of parts is also of importance in the design of the gripper. If the parts are presented in the same orientation each time to the gripper, or if the parts are symmetrical about all axes, the gripper can be designed to handle the part in just one orientation. However, if the parts are presented in a random fashion to the gripper, consideration must be taken to ensure that the gripper can successfully handle the part in all possible orientations. Grippers with multiple geometry features on them can be designed to handle all orientations of certain parts.

Lightweight parts, such as nuts, bolts, or particularly for this thesis, small pins can be fed directly to the part gripper on the robot. Since the weight of these parts is usually negligible relative to the payload capacity of the robot, many parts can be stored at the part gripper directly (in some kind of local part feeder); or, parts can be sent to the gripper by sending them through a tube with compressed air, for example. This kind of part presentation reduces the required motions of the robot to complete the programed task and allows the robot to place components faster.

4.3 Applications to the Pin Insertion Process

The pins in this application are small, lightweight components that lend themselves to being stored locally at the point of use on the part gripper itself. As such, the part gripper, referred to as the insertion head, is designed to store and feed the pins in a specially designed magazine. The magazine presents the pins to the insertion head in a consistent orientation. Delivering the pins in a consistent orientation means the insertion head can be optimized to work for that orientation, and does not have to handle different part orientations.

Having a large amount of pins available to the insertion head minimizes downtime spent waiting for a pin to feed, and allows the robot to focus its time on actually inserting pins into the PCB.

As discussed with tooling, the magazines as well as the insertion head were designed to be able to be changed by the robot without operator intervention. Each insertion head gantry has the ability to change insertion head tools to switch to a different diameter pin as well as the ability to change magazines to switch to a different pin type within that diameter, or to load a new magazine once the current one has been depleted.

Designing these parts to be interchangeable reduces the mass that the robot must carry while making moves since it does not need to carry an insertion head for pin types not currently required. Additionally, the ability to switch parts automatically by changing to a new magazine minimizes the amount of time required by an operator to set up the machine between production runs.

Chapter 5. Machine Design of Magazine and Insertion Head

The manual pinning process and the specialized automation process are still in use at SynQor as the primary methods for pinning a PCB. The pin insertion process discussed herein will become part of a pinning system to be used in production at SynQor. The systems designed in this group of theses will be further developed at SynQor to bring them to a production-ready state. The pinning system will incorporate a pin sorting machine [1], a pin insertion machine, a magazine to interface between sorting and insertion, and a control system to act as the director of all the subsystems [2].

The focus of this thesis is on the design and development of the pin magazine and the pin insertion mechanism. This chapter will describe the design specifications, the concept development process, and the final mechanical system design of the magazine and the insertion head mechanisms.

5.1 Project Scope

The pin insertion project described herein was developed to provide a new concept for a reliable and robust method to pin PCBs. The end-goal was to have a proof of concept prototype that was able to successfully orient a pin and grasp it for the pin insertion process. This proof of concept would later be attached to the existing positioning robot, and accordingly, must physically fit into the work envelope of the robot.

The basic design requirements of the pin insertion machine are:

- Ability to insert pins into a PCB at a rate of 1 pin/second;
- Run without operator intervention for approximately 4 hours;
- Ability to support the pin during pin insertion, and withstand the associated forces of 23lbf;
- Modularity, to allow for future integration into other types of pinning systems;
- Minimal complexity, for ease of manufacture and repair; and
- Reliability, to limit downtime caused by mechanism faults such as pins or components jamming.

The cycle time of 1 pin/second corresponds to the total throughput of the pinning machine when the insertion mechanism is attached to the positioning robot. As such, the cycle time of the insertion mechanism must budget time for the positioning robot to make the required moves between holes to be pinned on a PCB.

Similarly, the design requirements of the pin magazine are:

- Ability to feed pins to the insertion machine at a minimum rate of 1 pin/second to keep up with the insertion machine;
- Repeatably attach to the insertion machine by means of a locating mechanism; and
- Inexpensive to manufacture to reduce the cost of manufacturing a large number for the production version of the process.

Once a working prototype was established, the machine was to be tested to determine if it met the performance requirements. Additionally, the failures of the machine were to be quantified in terms of how often they occurred, and what the typical cause for a failure was.

5.2 Machine Specifications

Early in the design process, a number of key decisions were made that would ultimately control how the pin insertion mechanism functioned. A pin magazine was required as a result of the decision to “de-couple” the sorting and insertion process. The pin magazine would serve as an intermediate storage mechanism that would hold the pins in the orientation that the sorting process delivers them in. This pin magazine, would act as the interface between the upstream and downstream processes of sorting and insertion, respectively. As such, the sorting machine filled the magazine with pins, and the insertion mechanism was required to remove these pins from the pin magazine and transport them to, and press them in a PCB.

The developed pinning machine consists of three main components:

- Pin magazine;
- Insertion head; and
- Positioning robot.

In designing the specifications for this machine, we took into account aspects of the machine that will be developed in the future and implemented with the insertion head mechanism. The goal for the pinning process (outside the scope of this project) is to have the dual gantry positioning robot equipped with:

- Two insertion heads per gantry, for a total of four insertion heads (one each for the two least common pin types, and two for the most common pin type); and
- Storage for additional magazines within the robot's work envelope.

Each insertion head mechanism will be designed to be automatically changed by the robot without operator intervention. This means each gantry can utilize both insertion head mechanisms (for the different pin diameters) without requiring an operator to physically switch the insertion heads. Each gantry will also have within its work envelope a "magazine storage rack" that will enable the robot to automatically switch magazines when required.

5.2.1 Pin Magazine

The pin magazine is the interface between the sorting and insertion sub-processes. It must store pins that have been sorted and oriented and deliver them to the insertion mechanism in a reliable manner. Once the magazine is populated with pins from the sorting sub-process, it must hold the pins securely and contain a mechanism to singulate the pins to deliver them to the insertion head.

The magazine must be capable of storing enough pins to allow the insertion mechanism to run without operator intervention for approximately 4 hours in order to minimize the labor requirements to run the insertion machine. The target of pressing a pin at a rate of 1 pin/second yields:

$$1 \frac{\text{pin}}{\text{second}} = 14,400 \frac{\text{pins}}{4 \text{ hours}} \quad [5-1]$$

With a pin magazine that can store 250 pins, two simultaneous gantries operating, and two internal magazine storage racks per gantry that are capable of holding and automatically changing magazines with a storage quantity of 30, that yields a total unattended pinning time of:

$$250 \frac{\text{pins}}{\text{magazine}} * 30 \frac{\text{magazines}}{\text{gantry}} * 2 \frac{\text{gantries}}{\text{robot}} = 15,000 \frac{\text{pins}}{\text{robot}} \quad [5-2]$$

$$\frac{15,000 \frac{\text{pins}}{\text{robot}}}{1 \frac{\text{pin}}{\text{second}}} = 15,000 \text{ seconds unattended} \quad [5-3]$$

15,000 pins = 4.17 hours unattended

[5-4]

There are two shifts per day at SynQor, with a total working time of both shifts combined of roughly 16 hours. An interval of 4 hours between when operators must re-stock the machine with magazines means that the pinning machine will require operator attention four times each day.

In addition to the storage requirements, the magazine must be capable of delivering pins individually to the insertion mechanism. The mechanism to deliver pins must operate within the time window of 1 pin per second, while still leaving enough time for the insertion mechanism to successfully pin a board in the remaining time.

These magazines are being used in a production environment, and will be frequently moved by operators from an inventory area to the production floor. As such, the magazines need to be designed to be robust enough to handle the normal wear that occurs in a production environment. This means that fragile components need to be designed out, or if they are absolutely necessary for the mechanism to work, they should be properly protected from damage.

The weight of the payload on the robot, which is the weight of the magazine and the insertion head combined in this case, should be minimized to allow the robot to accelerate between points as quick as possible.

5.2.2 Insertion Head

The insertion head is a robotic end effector that is customized to handle the pins in this application. The insertion head is responsible for the task of accepting a pin from the pin magazine and orienting it vertically in a manner that allows the positioning robot to press a pin into a PCB (see Figure 21).

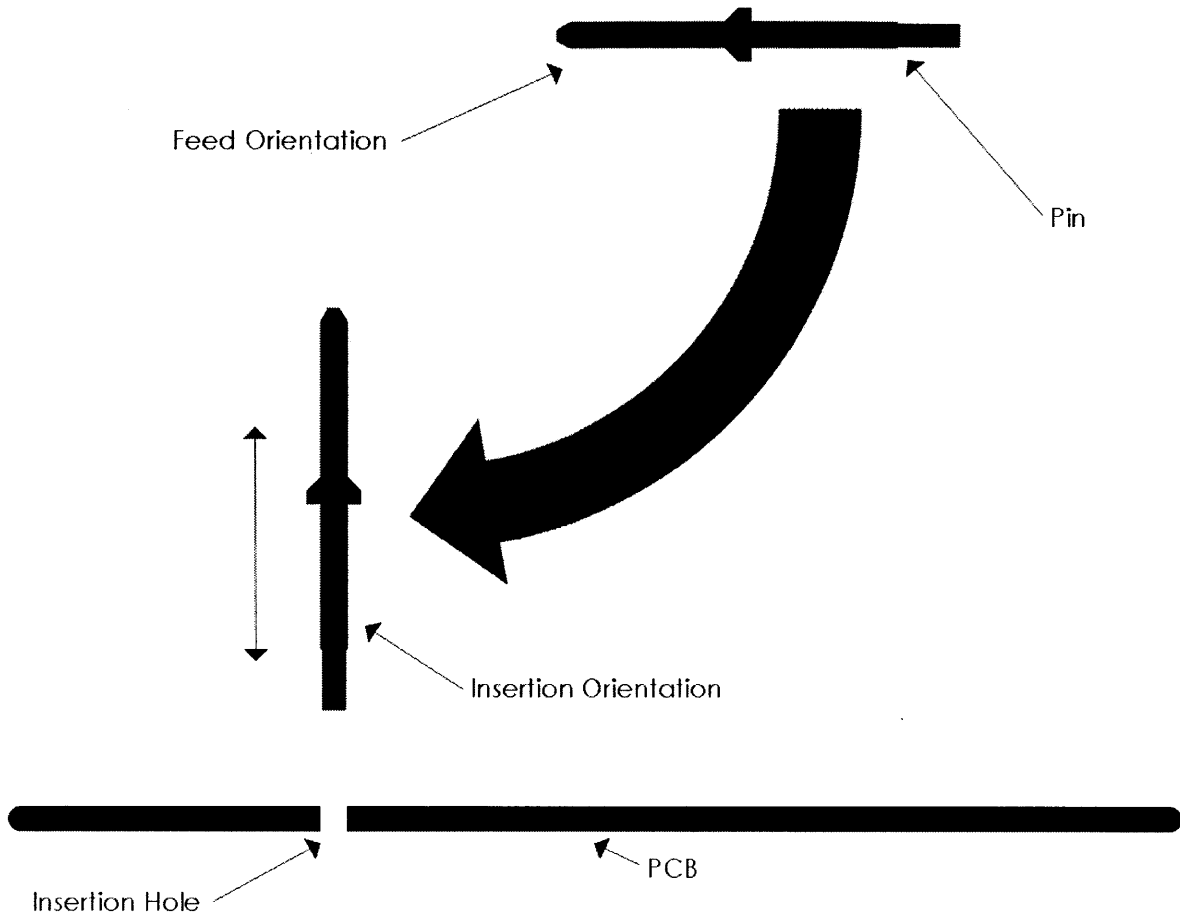

Figure 21 - Insertion head pin reorientation

The insertion head is the main structural component of the whole insertion mechanism. As such, it needs to be designed to be able to perform the following tasks:

- Support a load of 23lbf when pressing a pin into a PCB;
- Mechanically advancing the pin feeder in the pin magazine in order to feed a pin;
- Grasping a pin securely after it has been delivered from the pin magazine;
- Re-orienting the pin from the horizontal position as it is delivered to the vertical position for pressing into a PCB; and
- Firmly and repeatably holding a pin in the vertical position during the pressing process.

Also to be taken into consideration is:

- The weight of the insertion head. In order to improve performance of the positioning robot, the insertion head should weigh as little as possible to reduce the payload on the robot.
- The number of actuators, sensors, and controlled axes of motion. Each actuator or sensor requires an additional input or output from the machine control unit. [2]

5.3 Final Design

The pin magazine is a sub-assembly that is capable of holding roughly 250 pins. These pin magazines will be controlled in inventory by SynQor's production control software. The software will keep track of how many pins are left in each magazine, and what pin type is stored in the magazine. The magazine is responsible for pin storage, as well as pin feeding and transportation to the insertion head. Detailed design of the magazine can be found in Section 5.3.1.

The insertion head is the mechanism that accepts pins from the magazine and orients them for insertion in the PCB. Once the pin is fed from the magazine, the insertion head takes the pin from its horizontal orientation and re-oriens it vertically. In the vertical position, the pin can be pressed into the PCB. Detailed design of the insertion head can be found in Section 5.3.2.

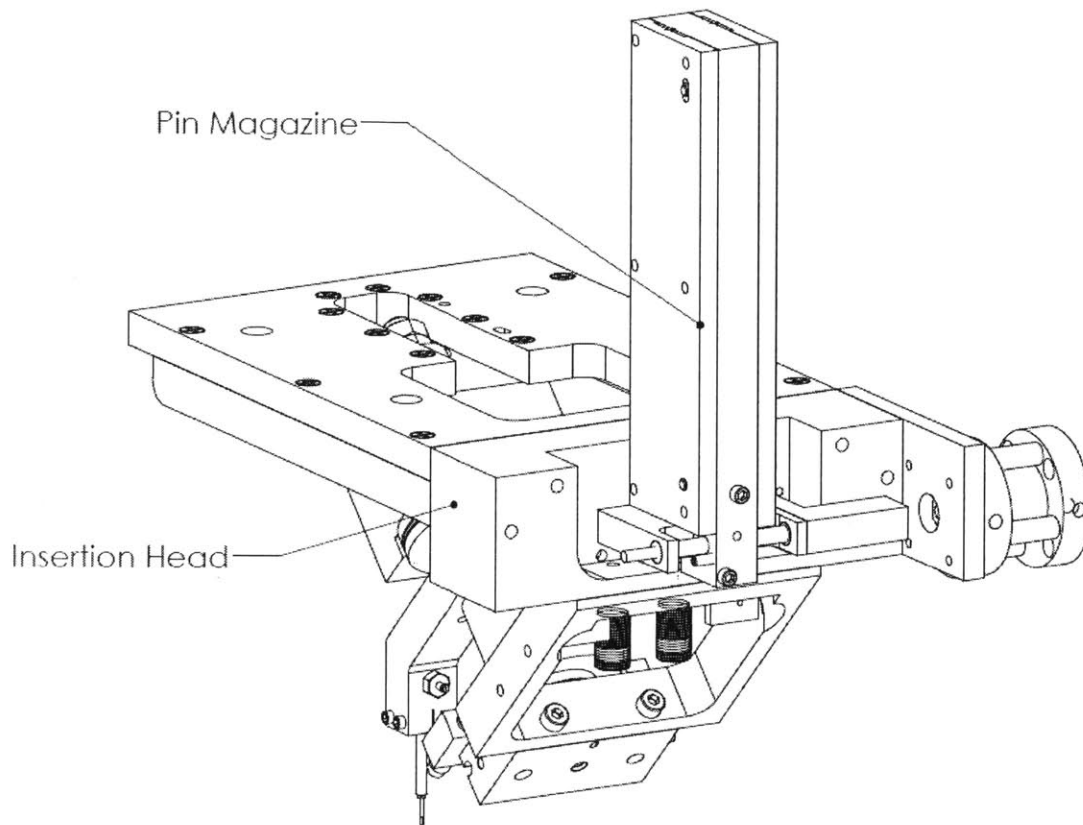

Figure 22 - The insertion head and magazine

The positioning robot will serve as the control of the pinning machine. The insertion head and magazine will both be fixed to the carriage on the positioning robot's axes. The positioning robot is responsible for moving the insertion head to the correct position in the XY plane relative to the PCB, and then descending in the negative Z direction to press the pin into the circuit board. The coordinate frame about the PCB is shown in Figure 23.

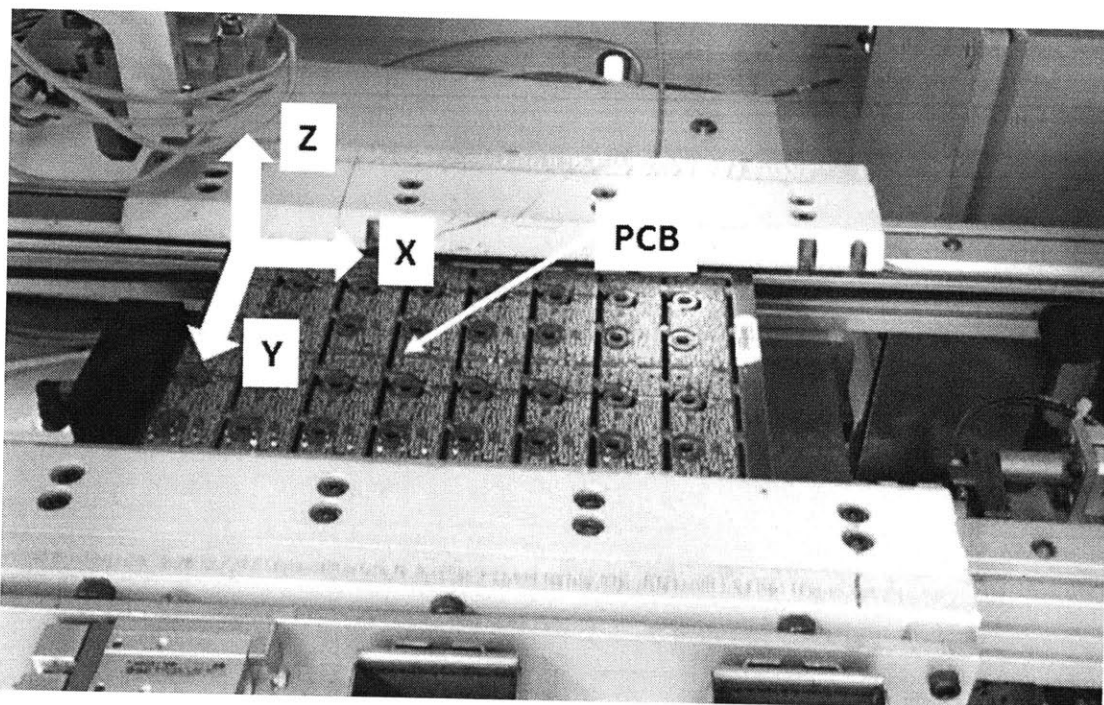

Figure 23 - Board coordinate frame in the positioning robot. The origin lies on the top plane of the PCB.

The positioning robot was not designed as a part of this project. It was designed and built previously for another pinning process, and is being re-purposed for this pinning project. As such, the design and specifications of the positioning robot are not discussed in detail in this chapter.

The positioning robot also has auxiliary functionality that includes:

- Scanning incoming PCB barcodes to determine the correct pin type, and pin locations used for that PCB;
- Calibrating new tools when repair or maintenance is performed to the insertion head; and
- Various diagnostic features.

Figure 24 shows a flowchart of the sub-processes within the insertion process.

The pins begin the insertion process in the magazine. A feeder mechanism within the magazine delivers pins to the insertion head, and subsequently the insertion arm. The insertion arm orients the pins vertically so they can, finally, be pressed into a PCB.

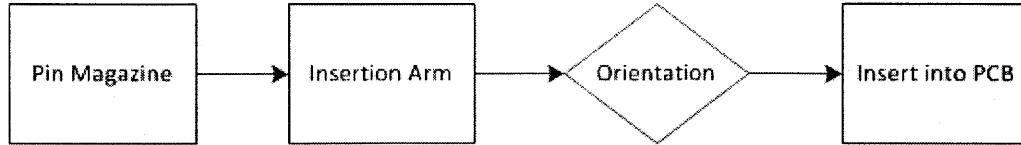

Figure 24 - Insertion head process schematic.

5.3.1 Pin Magazine

The pin magazine consists of two pin tracks side by side to each other. The pin tracks are each capable of holding 70 0.040" pins. The pins are stored parallel to each other in the pin tracks. At the bottom of the pin tracks, there is a feed mechanism that has a slide with a recess in it designed to accept a pin from one of the tracks and shuttle it to the centerline of the pin magazine. At the centerline of the pin magazine, the pin is in line with the insertion tube in the insertion head. The magazine then pushes the pin with compressed air out of the magazine towards the insertion tube. The process repeats until the magazine is depleted or a new magazine is called for by the machine control.

Figure 25 shows a basic layout of the pin magazine. The pin eject port is the point at which the pin is ejected from the magazine and sent to the insertion head. The feeder slide is actuated back and forth to feed pins off the bottom of the stacks of pins in the pin tracks and bring them to the pin eject port. Figure 26 shows the motion of the feeder slide when feeding a pin. And, finally, Figure 27 shows the path of the pin out of the magazine after the feeder slide has brought the pin to the eject port.

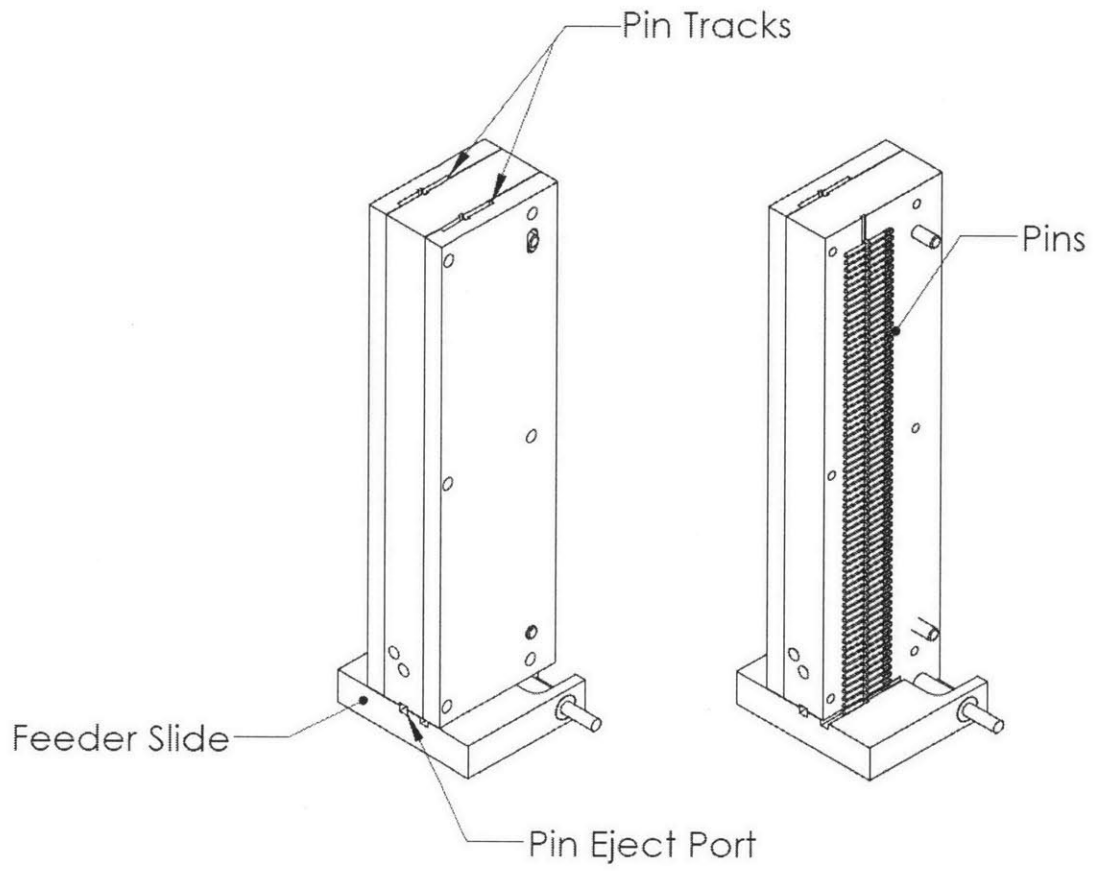

Figure 25 – Magazine assembly (left); open magazine assembly showing pins stacked within the pin tracks (right).

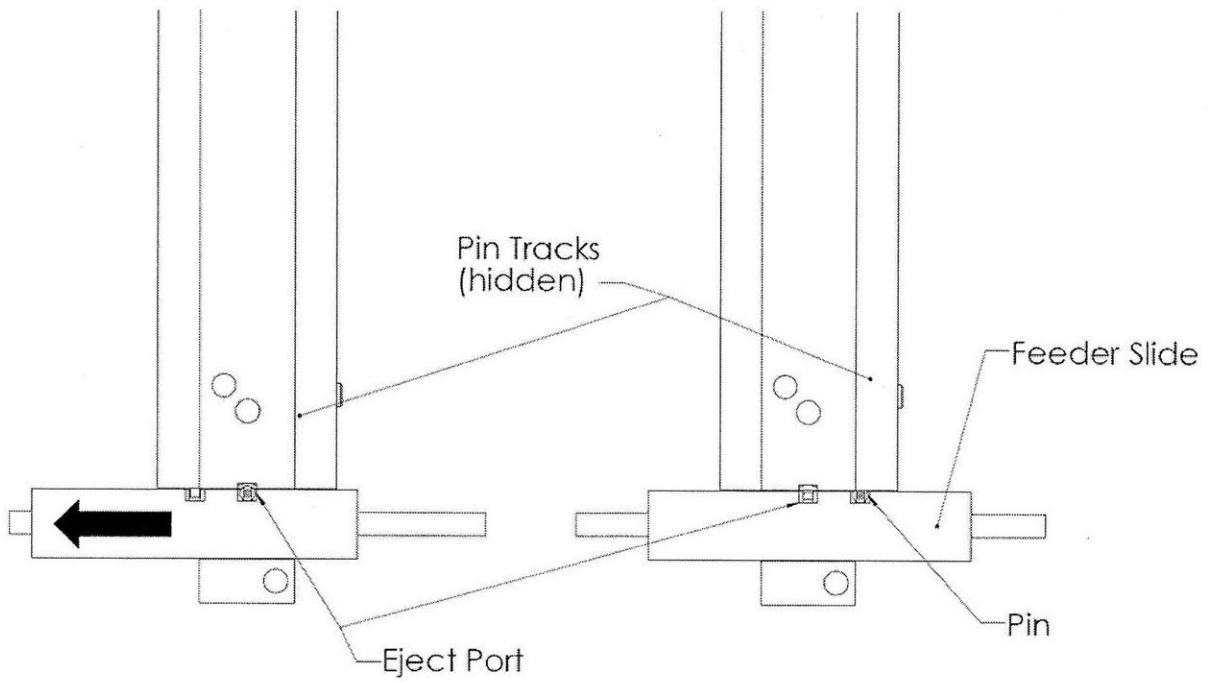

Figure 26 - Motion of the feeder slide when feeding a pin. The slide is forced to the left which brings a pin from the pin track in-line with the eject port.

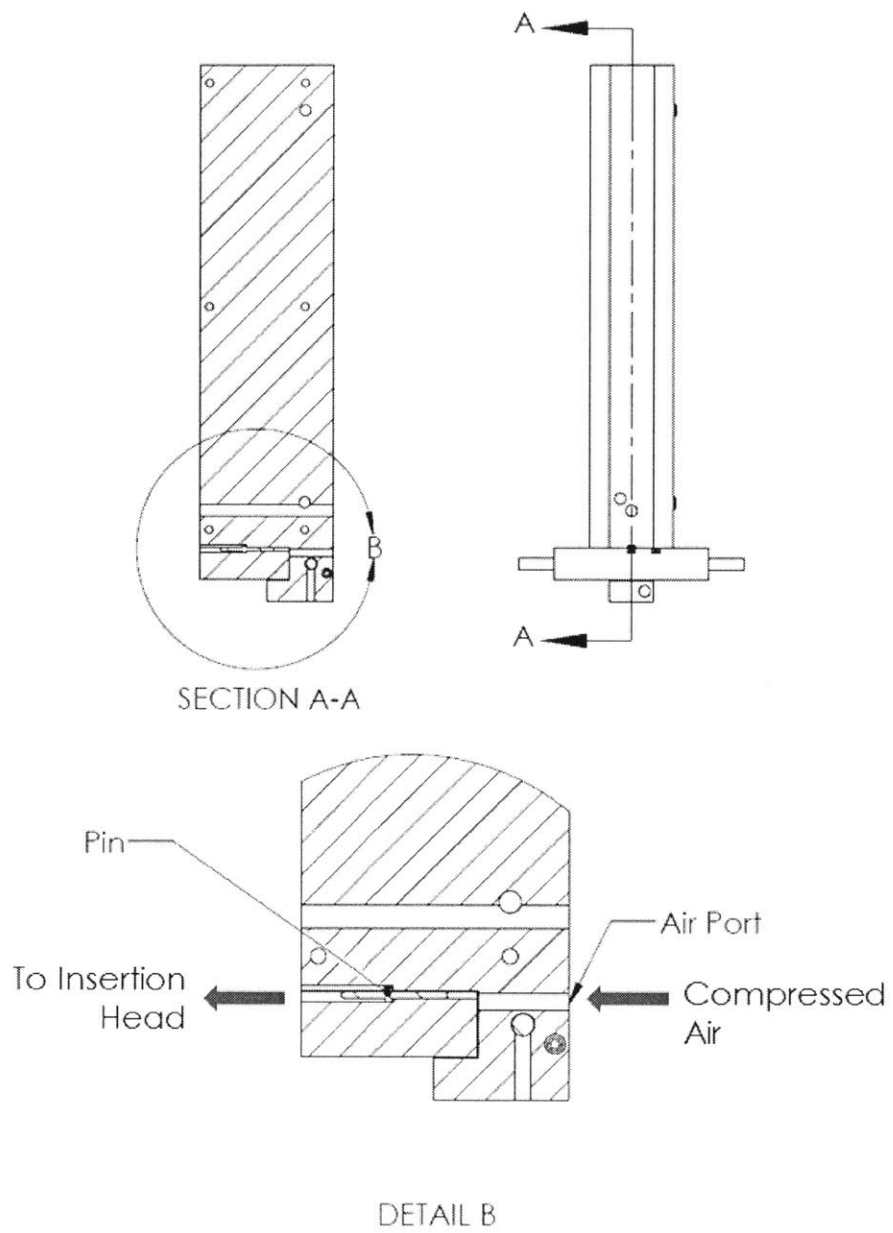

Figure 27 - Section view showing path of pin being ejected from the magazine towards the insertion head.

5.3.2 Insertion Head

The insertion head is the end effector that will be attached to the positioning robot that holds a pin for insertion into a PCB. There are three sub-systems of the insertion head:

- Chassis;
- Pin Escapement; and
- Insertion arm.

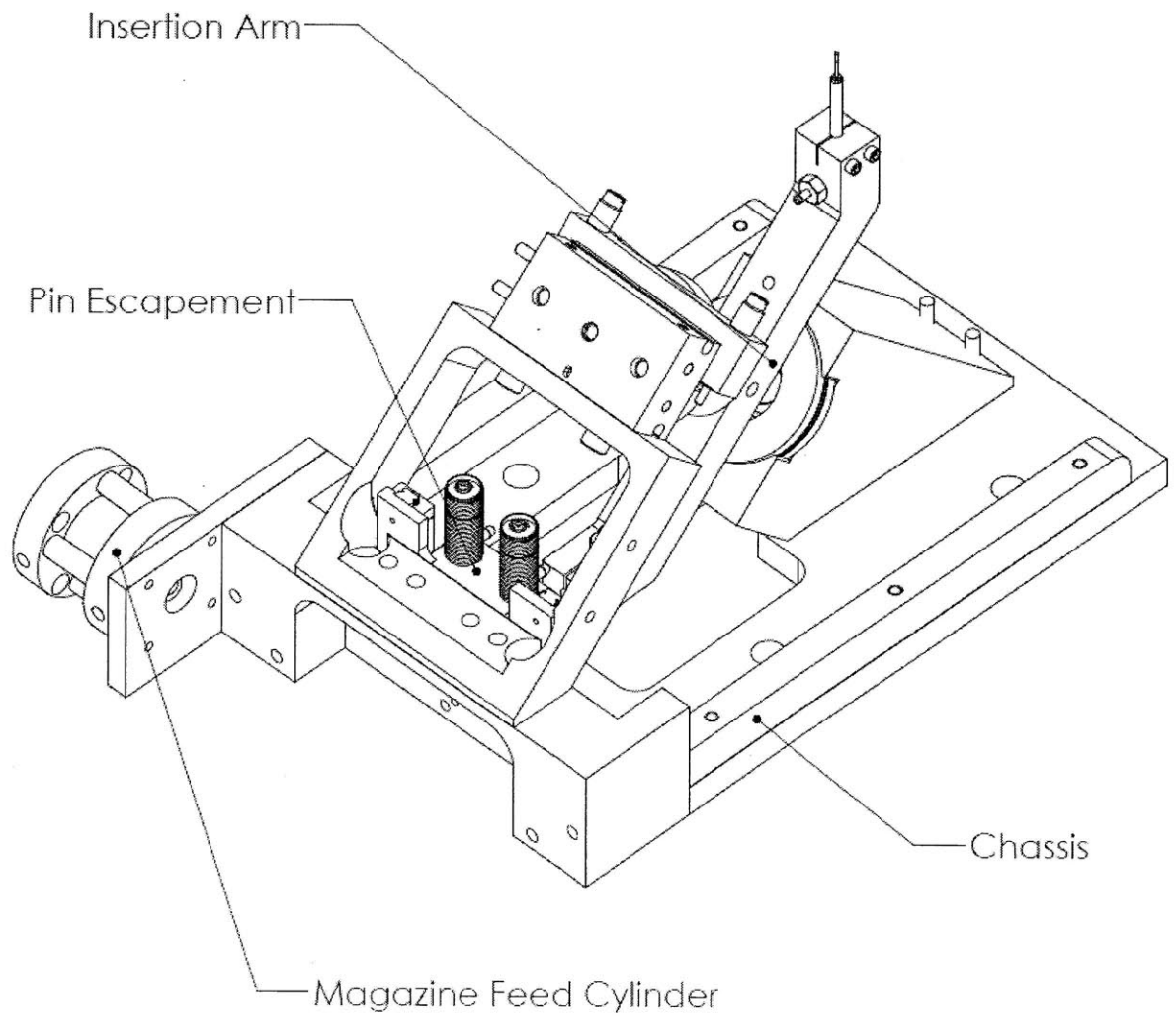

Figure 28 - Insertion head assembly (shown upside down for clarity).

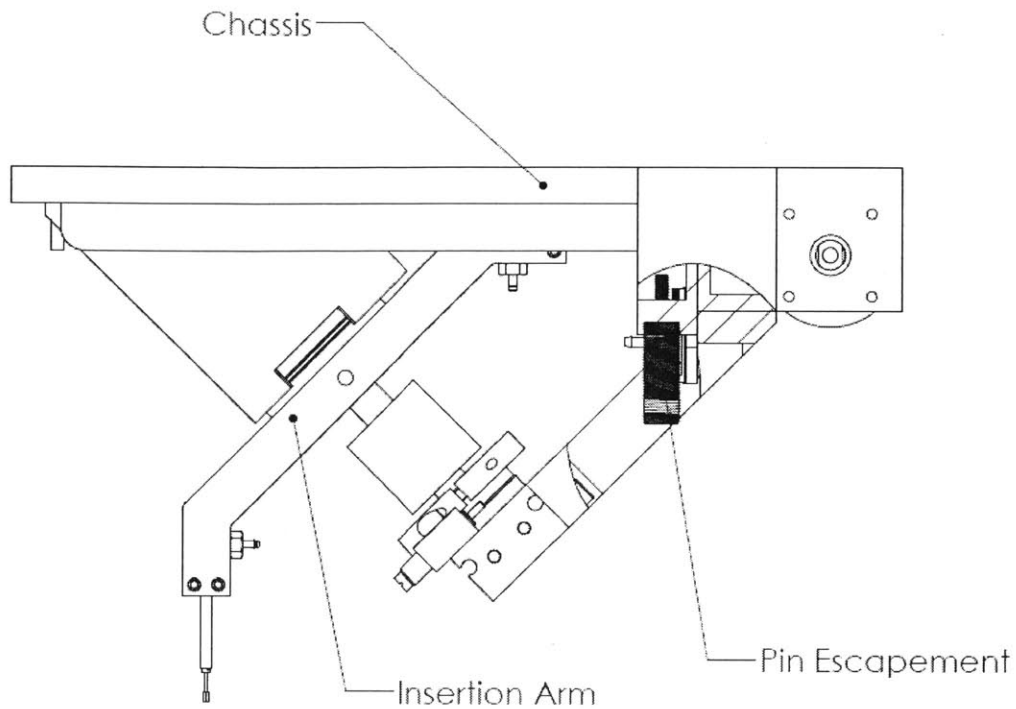

Figure 29 - Insertion head assembly side view (broken-out view to show pin escapement).

5.3.2.1 Chassis

The chassis for the insertion head serves a number of functions. In addition to being the “backbone” for all the auxiliary components included in the insertion head, it:

- Mounts and locates the pin magazine
- Provides a physical guide for pins to move from the magazine to the pin escapement; and
- Locates the insertion arm relative to the magazine.

Figure 30 shows an isometric view of the insertion head chassis, and labels the important functional areas of the assembly.

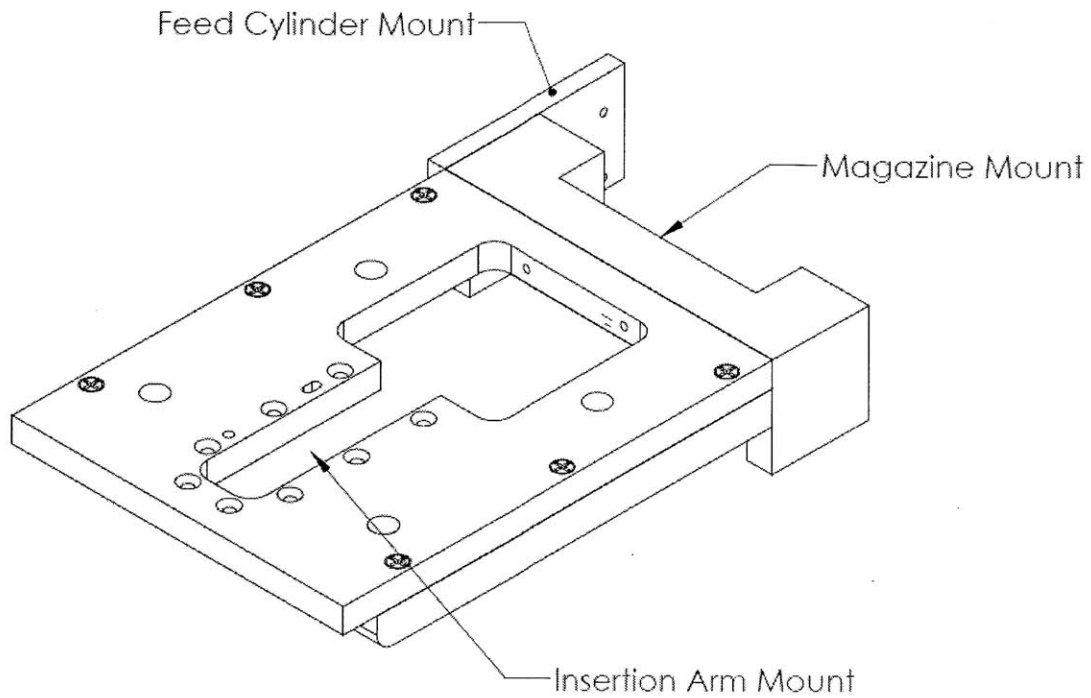

Figure 30 - Functional areas of insertion head chassis.

The pins are guided from the magazine to the insertion arm via a hole in the chassis and then through the pin escapement.

5.3.2.2 Pin Escapement

The pin escapement is a mechanism that extends the pin eject port on the magazine to the insertion arm. The two gates present in the pin escapement translate vertically, in opposite directions, once the pin has been grasped by the insertion arm. The movement of the gates creates clearance to either side of the pin which allows the insertion arm to swing the pin out horizontally in either direction.

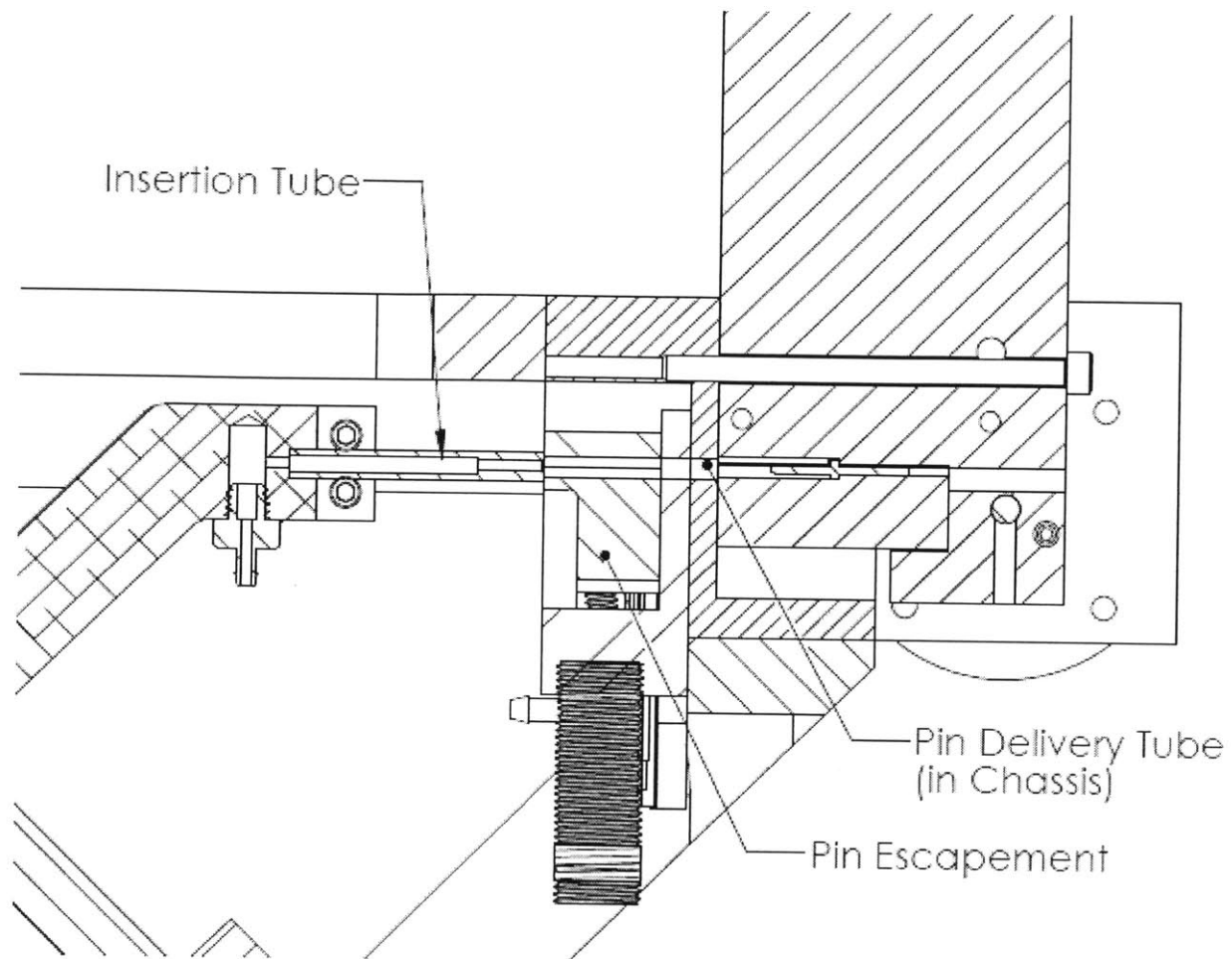
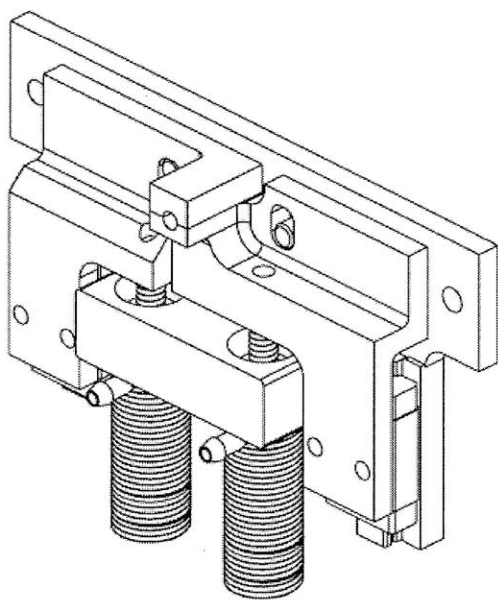
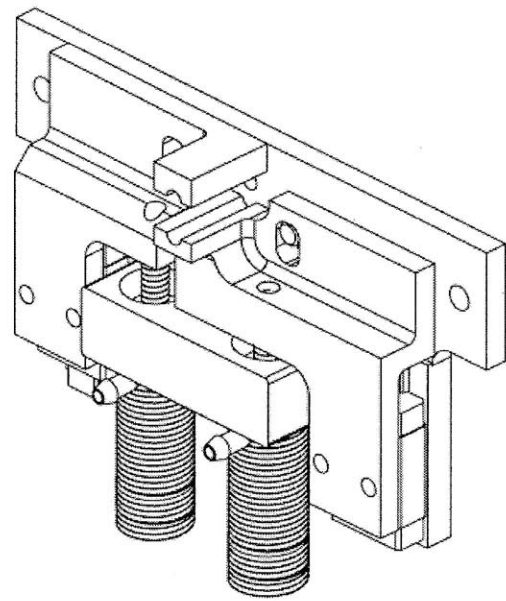

Figure 31 - Section view showing how the pin escapement extends from the pin eject port to the insertion tube.

The gates are actuated by two small pneumatic double acting cylinders that provide the necessary force to push and pull the gates. The cylinders in use are Bimba Mead MA-250x0.25DA-RB (see Appendix Figure 58). Figure 32 shows the pin escapement in both states, opened and closed.



Pin Escapement "Closed"



Pin Escapement "Open"

Figure 32 - Pin Escapement in the closed position (left); pin escapement in the open position (right)

Each gate is guided by a miniature linear ball bearing slide. These linear slides ensure the motion of the gates is smooth and consistent. Figure 59 (Appendix) shows an exploded view of the pin escapement with all the parts of the assembly labeled. The ball bearing slides in use are Nippon Thompson Model 101025 (rail) and ML5C1PS2 (carriage).

Located vertically above the centerline of each of the pneumatic cylinders is a pin which is pressed into the base plate of the pin escapement. This pin serves as a hard stop in either direction to limit the vertical push and pull displacement of each cylinder. The total stroke of each gate is 0.1" – therefore, the total opening created when the gates are retracted is 0.2".

5.3.2.3 Insertion Arm

The insertion arm is a rotating arm with two insertion tubes at each end of the arm. Each insertion tube is of the dimensions 1/8" outside diameter x 0.043" inside diameter and about 1-1/8" long. The insertion arm rotates to two positions:

1. Pin loading
2. Pin insertion

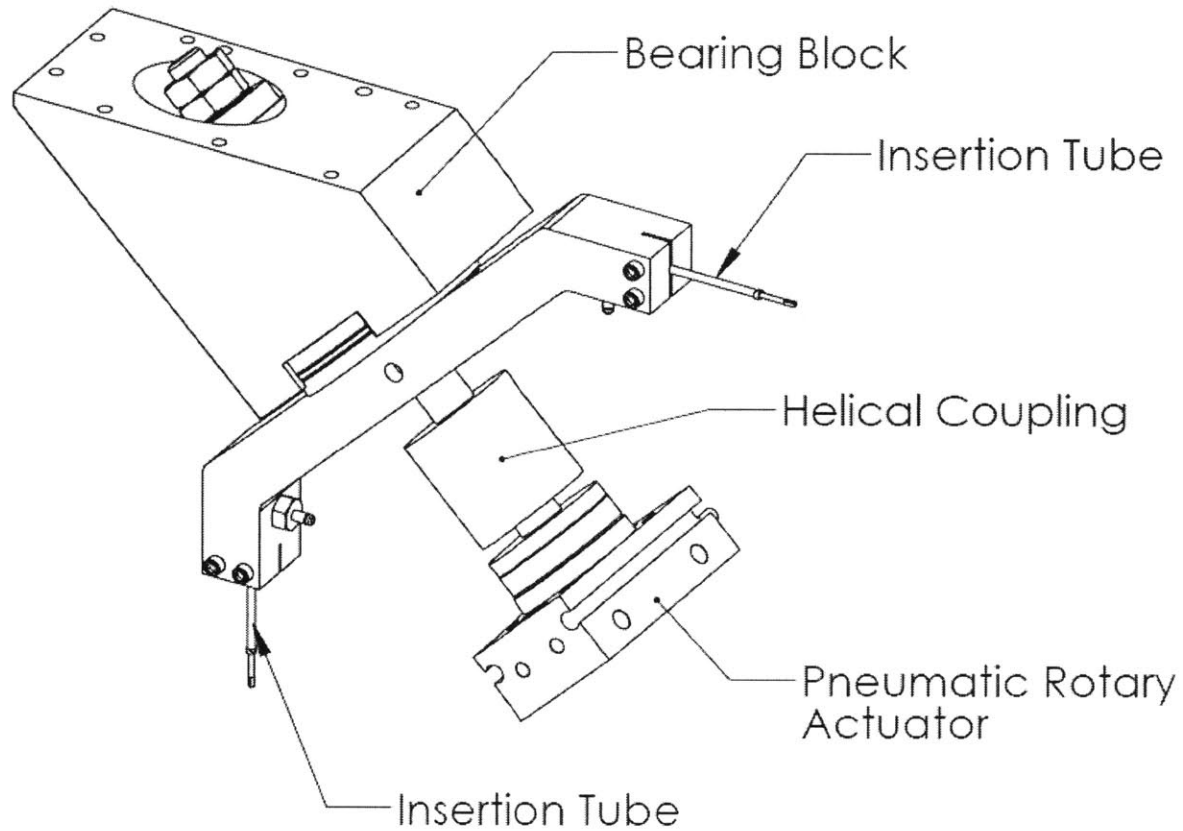

Figure 33 - Insertion arm assembly.

In the pin loading position, the insertion tube is in line with the pin eject port and the pin escapement. Vacuum pressure in the insertion tube draws the pin into the tube and secures it against the collar (see Figure 36). Once the pin is secured, the insertion arm is ready to be rotated to the next position, pin insertion.

In the pin insertion position, the pin is oriented vertically and can be pressed into the PCB. Since the insertion arm is double ended, a pin can be pressed into the PCB while another pin is being loaded into the opposing insertion tube.

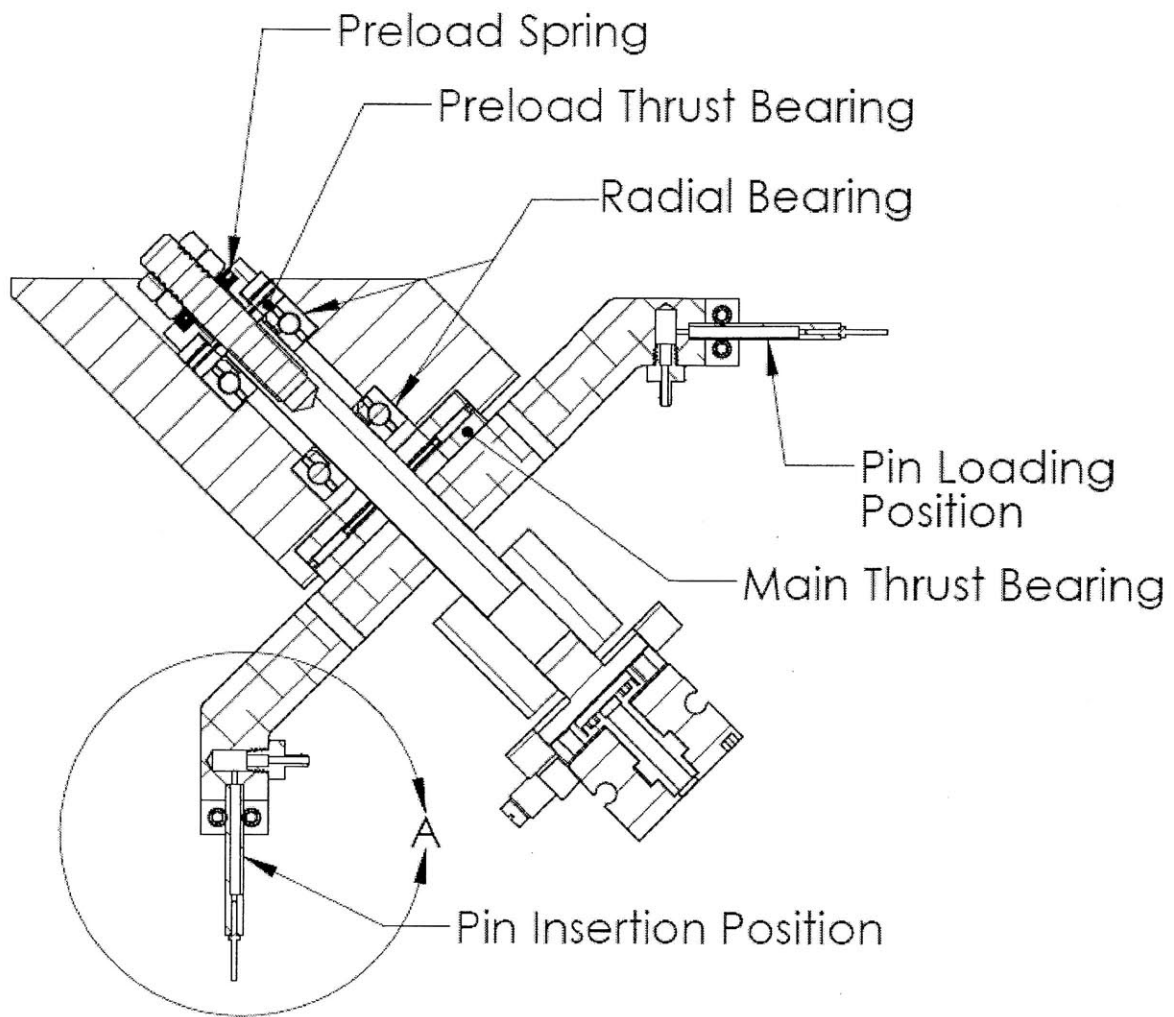

Figure 34 - Section view of insertion arm showing bearing arrangement and insertion arm positions. The insertion arm rotates about the two radial bearings shown.

The insertion arm is actuated by a double-acting rotary pneumatic cylinder (SMC Model MSQB2A). The rotational motion of this cylinder is controlled by two hard stops that allow the rotation to be precisely adjusted to align the insertion tube to the pin escapement (See Figure 35).

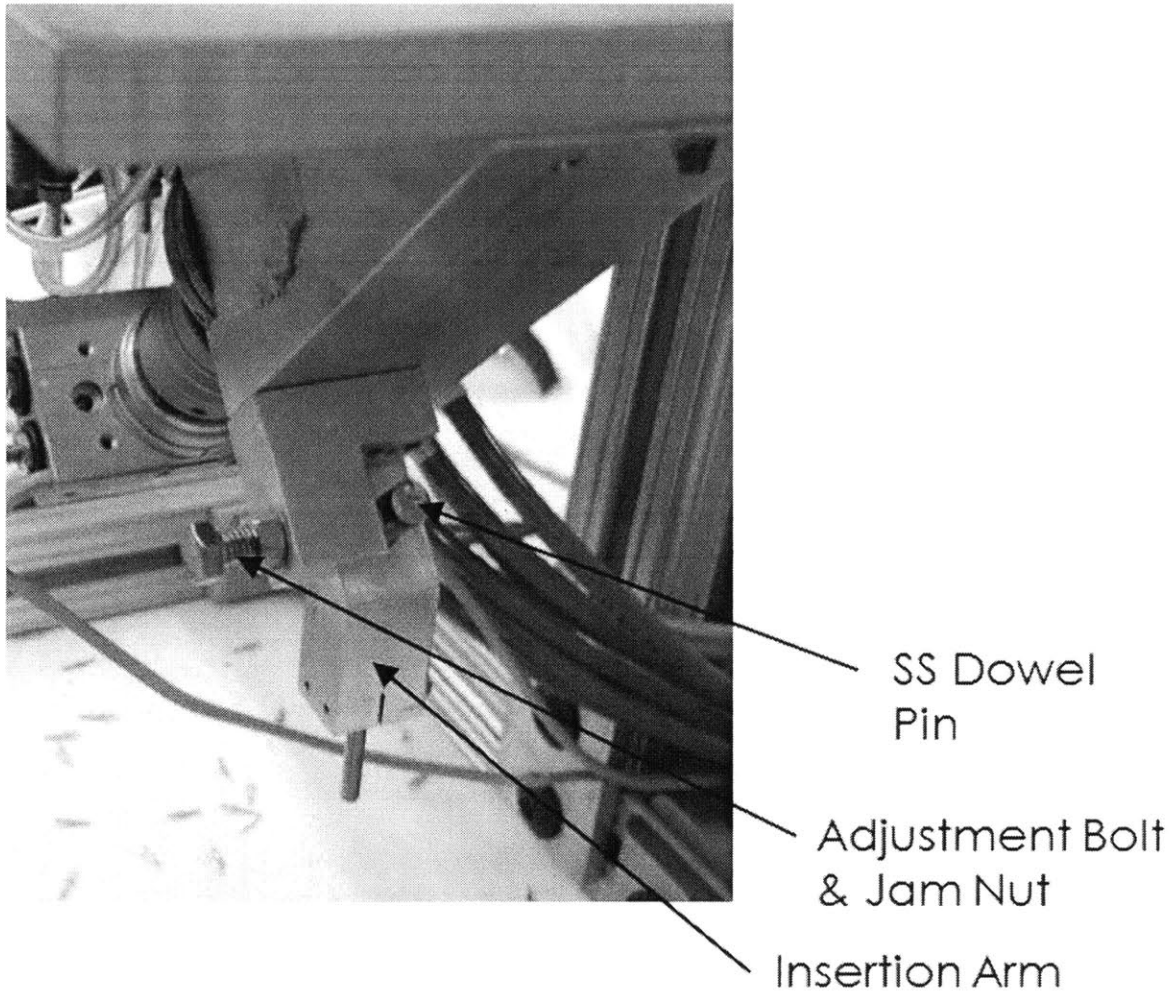
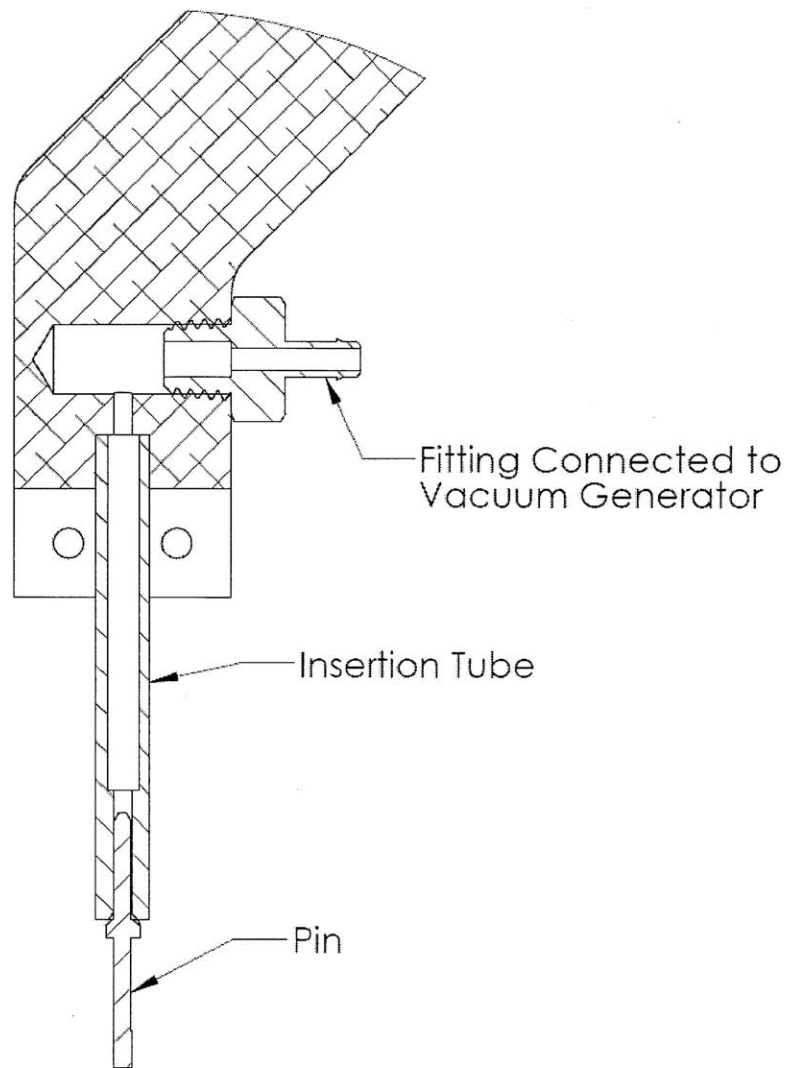

Figure 35 - Hard stops that constrain the motion of the rotary actuator.

In the bearing block for the insertion arm, there are two radial bearings, one main thrust bearing, a preload thrust bearing, a preload spring, and the rotational shaft. Figure 34 shows the bearing arrangement in the insertion arm assembly.



DETAIL A

Figure 36 - Diagram of the insertion tube with a pin seated against the collar.

The insertion tube is a 1/8" diameter stainless steel dowel pin with special geometry to assist the pin in seating itself in the insertion tube. A chamfer at the leading edge of the insertion tube guides the head of the pin into the tube, and vacuum pressure completes the process of seating the pin against the collar.

Chapter 6. Design Methodology for the Magazine and Insertion Head

There were a number of key decisions made when designing the pin magazine and insertion head. These decisions ultimately shaped the final design of each respective mechanism. This chapter describes the reasoning behind these decisions.

6.1 Pin Magazine

The pin magazine is responsible for two main tasks:

- Pin storage; and
- Pin feeding to the insertion head.

These functional areas were developed based on the design requirements outlined in Section 5.2.

6.1.1 Pin Storage

The pins are stored in profiled tracks cut in the magazine (see Figure 25). These tracks hold the pin by the collar which allows one magazine to be used for all 8 different lengths of pins since the collar dimensions do not change as the length varies. The pins are fed by gravity down the pin tracks as they are loaded by the sorting machine. [1]

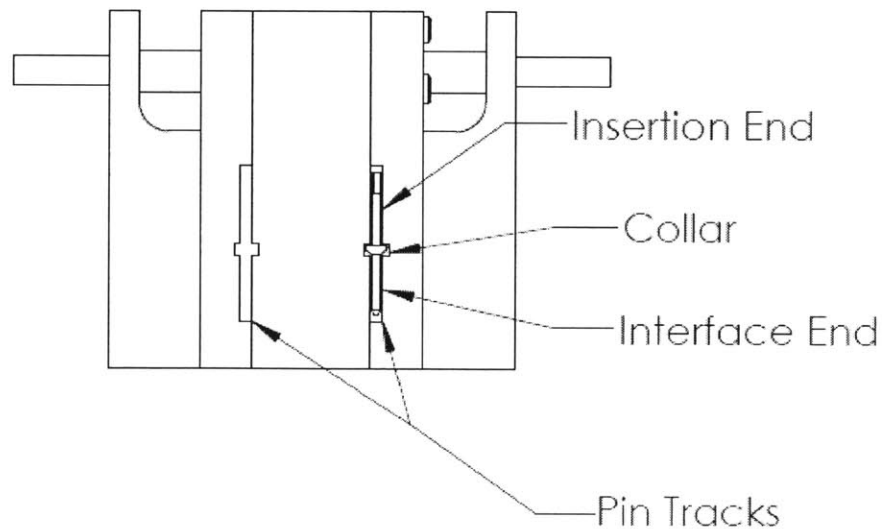

Figure 37 - Detail view of pin tracks. The collar is used to locate the pin and guide it down the pin tracks, which allows the magazine to store pins of any length of a given diameter.

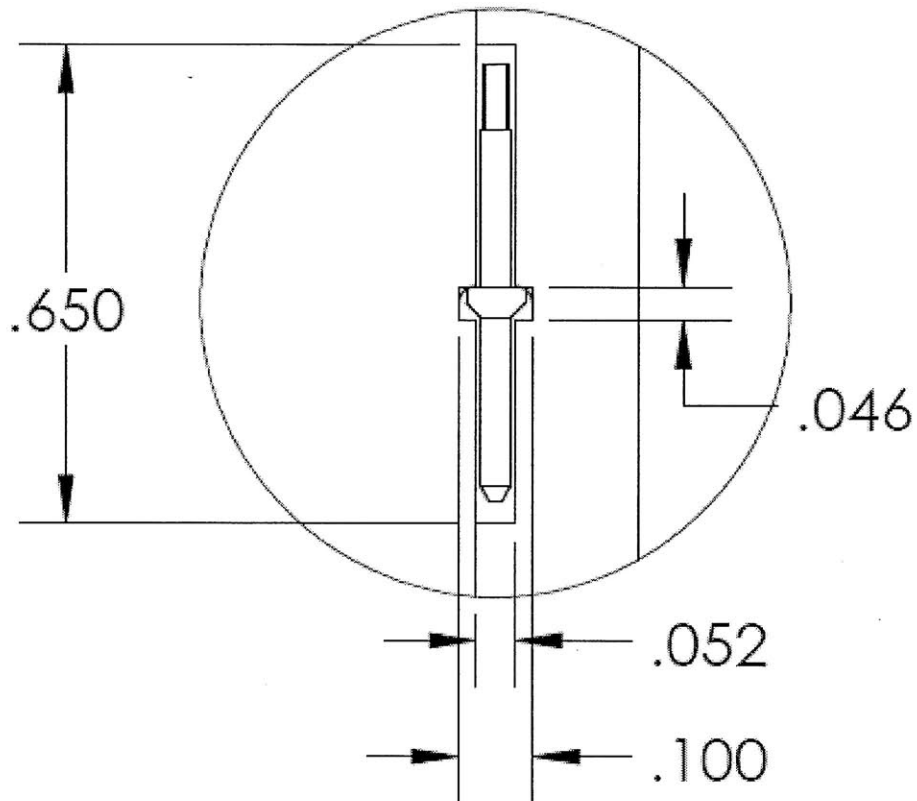

Figure 38 – General dimensions of the pin track (inches).

6.1.1.1 Feeder Slide Dwell Time

The pin feeder slide must dwell under each pin track for approximately 18ms in order for the pins to fall into the recesses on the feeder slide by gravity. This time value is equivalent to the time it takes an object to fall approximately 0.06" vertically. The distance to fall is equivalent to the depth of the recess in the feeder slide, which is approximately 0.06".

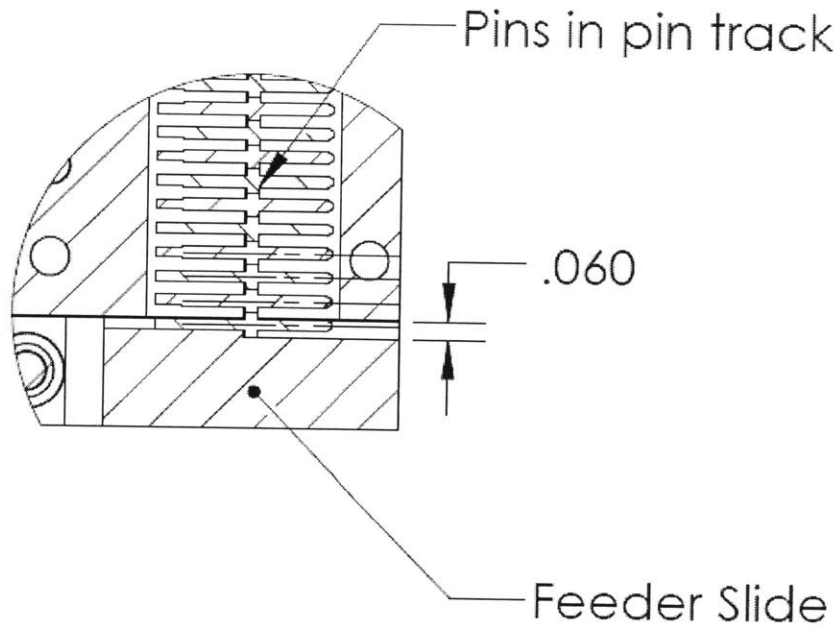

Figure 39 – Distance pin must fall from the pin track to the feeder slide in the magazine once the recess in the feeder slide is underneath a pin track.

Using the kinematic equation:

$$d = \frac{1}{2}at^2 \quad [6-1]$$

Re-arranging to:

$$t = \sqrt{\frac{2d}{a}} \quad [6-2]$$

Where, a , acceleration is equal to the acceleration due to gravity, or:

$$g = 386.0 \frac{in}{s^2} \quad [6-3]$$

Plugging back in to equation [6-2] we have:

$$t = \sqrt{\frac{2 * 0.06in}{386.0 \frac{in}{s^2}}} = 18ms \quad [6-4]$$

Thus, the feeder slide must dwell under each pin track for a minimum of 18ms in order for a pin to have enough time to enter the recess in the slide.

Once a pin is fed from the tracks into the recess on the feeder slide, the feeder slide is moved laterally which brings the pin that is in the recess in line with pin eject port on the magazine.

6.1.2 Pin Feeding to Insertion Head

The feeder slide is actuated by means of a small pancake-style air cylinder. This cylinder extends and retracts to move the recesses in the feeder slide under the pin tracks, and in line with the eject port on the magazine. The eject port of the magazine is in line with the centerline of the pin magazine.

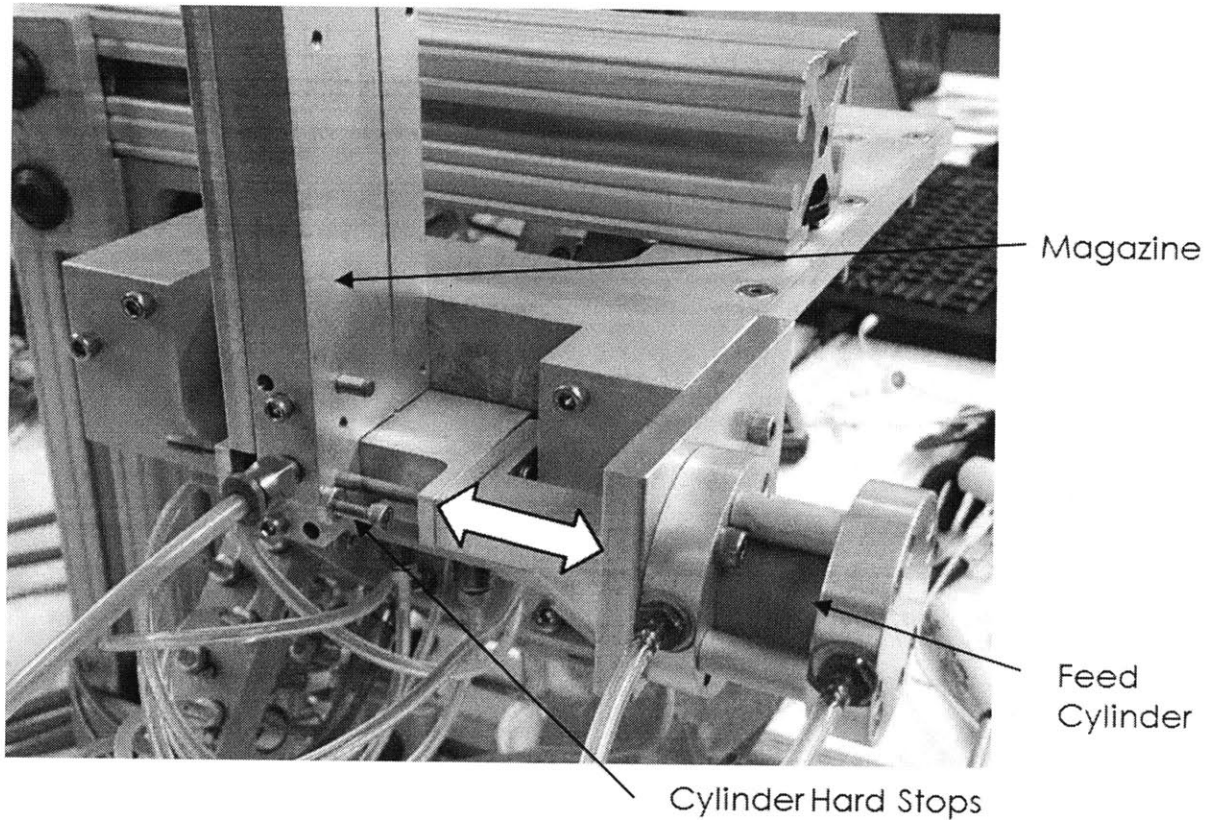

Figure 40 – The “pancake” style air cylinder acts as a feed cylinder to actuate the feeder slide back and forth as indicated by the arrow. The motion of the cylinder is adjusted through the use of two adjustable hard stops that hold the feed plate in the load position and the eject position.

Once a pin is in line with the pin eject port, an air port behind the pin blows compressed air that shuttles the pin out of the magazine and towards the insertion tube (see Figure 27). At this point, the pin has left the magazine and is now under the control of the insertion mechanism. The process repeats by cycling the feeder slide back and forth as dictated by the control program.

6.2 Insertion Head

There are a number of key components and systems in the insertion head that warrant further discussion and explanation. These components include:

- The pin escapement;
- The pneumatic system that actuates the insertion head; and
- The bearing arrangement that supports the insertion arm.

6.2.1 Pin Escapement

The pin escapement is a mechanism to guide the pin to the insertion tube, and to allow the pin to translate horizontally out of the pin delivery slot once it is seated in the insertion tube. The pin escapement is located behind the pin delivery slot in the insertion head chassis. Figure 29 and Figure 31 show the location of the pin escapement. Figure 41 shows a picture of the actual pin escapement as it was built.

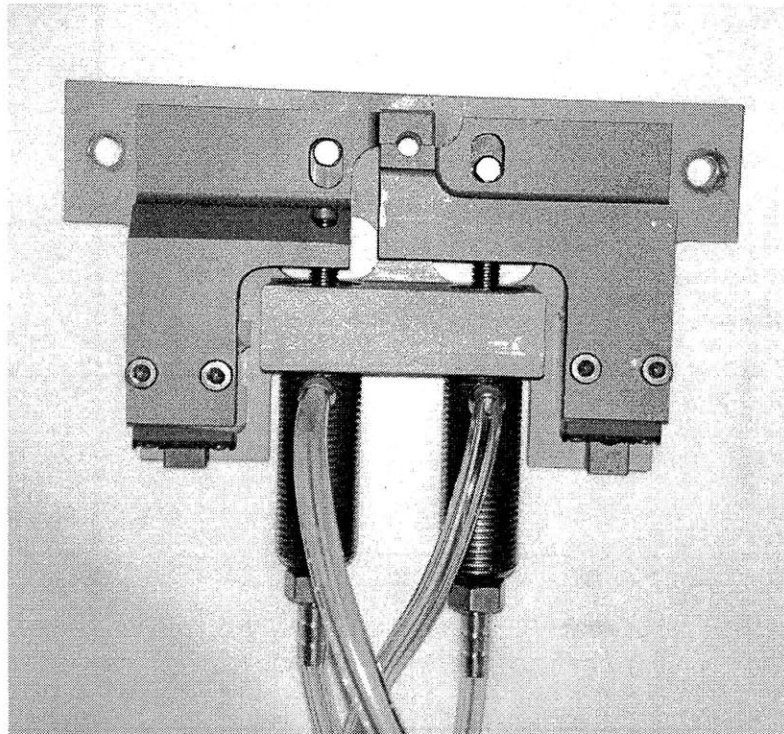

Figure 41 - Picture of the pin escapement as built.

The pin escapement consists of two “gates” that are actuated by pneumatic cylinders and guided by linear ball bearing slides.

The small pneumatic cylinders (see Appendix Figure 58) were chosen for their compactness and their easy mounting method. The whole body of the cylinder is threaded, which makes mounting the cylinders as easy as drilling and tapping one hole per cylinder. The double acting action of the cylinders means that pressure is applied via air in both the pull and push direction. This is opposed to single acting cylinders that only have pressure applied in *either* the push or pull direction – usually the non-pressurized side of the single acting cylinder is acted upon by a spring. This type of cylinder is referred to as “single acting spring return”. The double acting cylinder allows the gates in the pin escapement to be “forced” against a hard stop which accurately and repeatedly locates the pin gate at a precise position each time the cylinder is actuated. The hard stops are 1/8” OD x 1/4” long stainless steel dowel pins pressed into the pin escapement base.

The pin gates need to be guided in the vertical direction to keep them running straight and locating properly. This is done by the use of miniature linear ball bearing slides. The rails of these slides are fixed to the pin escapement base, and the carriages are fixed to the pin gates. These carriages guide the pin gates when the cylinders are retracted and extended.

Actuating the two air cylinders opens and closes the pin escapement. Figure 42 shows the pin escapement in these two states.

Appendix Figure 59 shows an exploded view of the pin escapement with all the components labeled.

Figure 59 - Exploded view of the pin escapement with labeled parts.

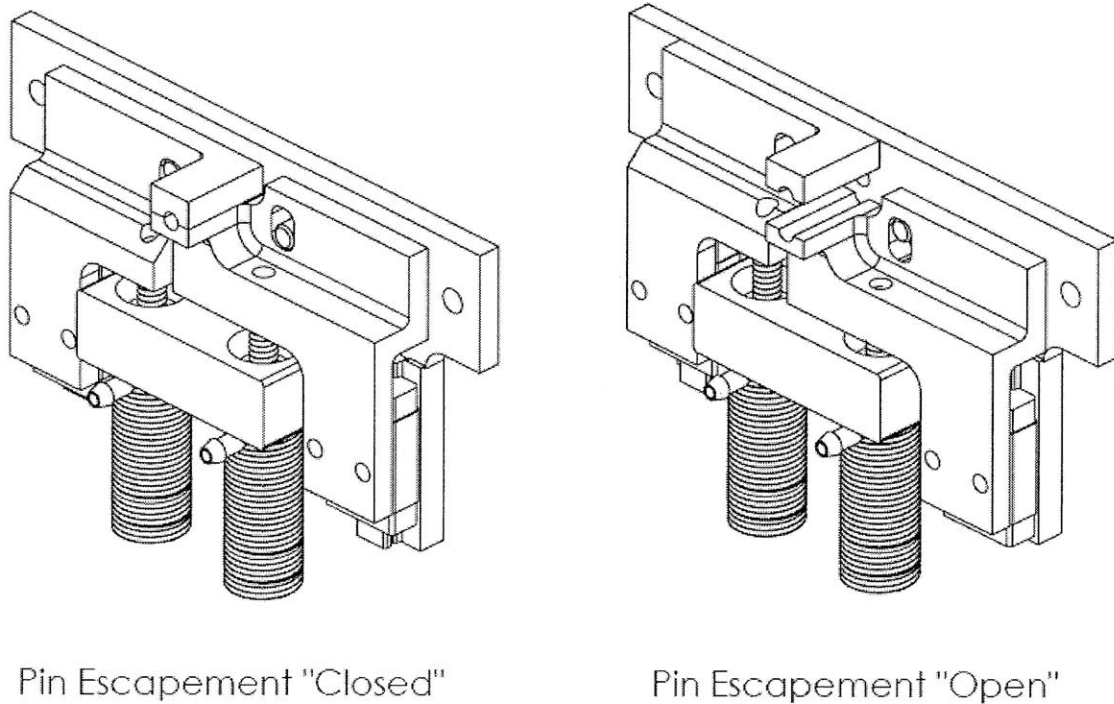

Figure 42 – Pin Escapement in the “closed” position (left), and the “open” position (right).

6.2.2 Pneumatic System

The insertion head is controlled by a number of pneumatic actuators and components. These components include:

- Two double acting linear pneumatic cylinders for the pin escapement;
- One rotary pneumatic actuator to rotate the insertion arm;
- Two vacuum generators to seat pins in the insertion tubes
- One “pancake” style air cylinder to actuate the feed slide in the pin magazine; and
- One air port in the pin magazine to shuttle the pin out of the magazine towards the insertion head.

Each of the components is controlled by electronically actuated solenoid valves which are, in turn, controlled by a programmable logic controller, described in [2]. Figure 44 shows how all of the pneumatic components are connected to one another and their general physical layout.

The solenoid valves in use are FESTO 5/2-way valves; model MYH-5/2-2.3-L-LED (Figure 43). They are designed to operate double-acting cylinders. There are two output ports on the valve. When power is not applied to the solenoid, one of the outputs (A) is exhausted, and the other (B) is pressurized. When power is applied to the solenoid, the outputs are switched so that port A is pressurized, and port B is exhausted. To control the components that require only that the air flow be turned on or off at one port (i.e. vacuum generators), one of the output lines are simply plugged, and the other output line can then be used as a switched source of air pressure.

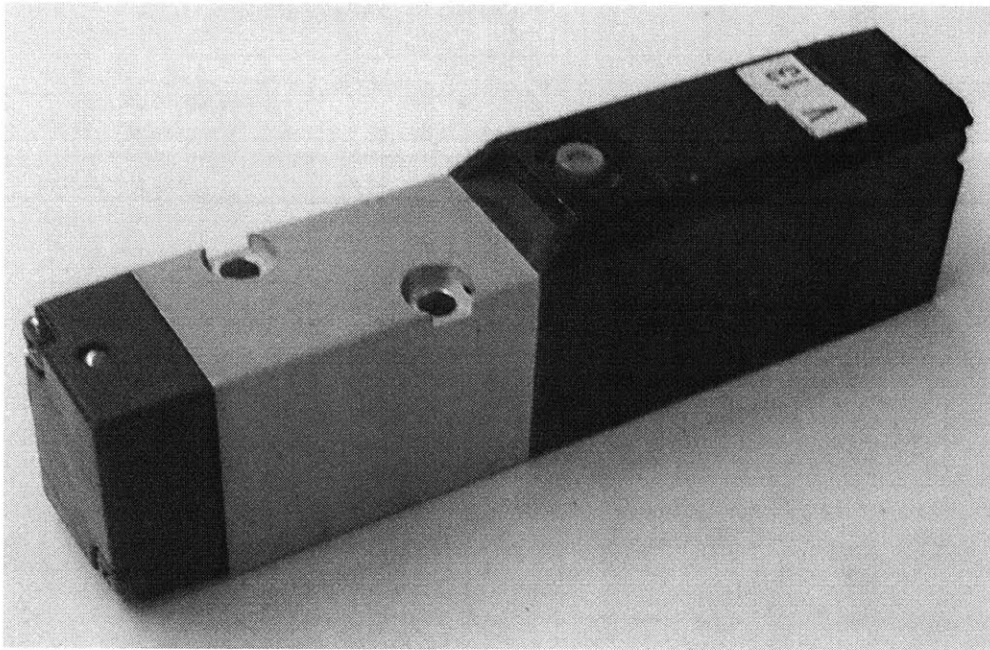

Figure 43 – Festo MYH-5/2-2.3-L-LED Solenoid Valve Front view. Appendix Figure 57 shows a rear view of the solenoid valves.

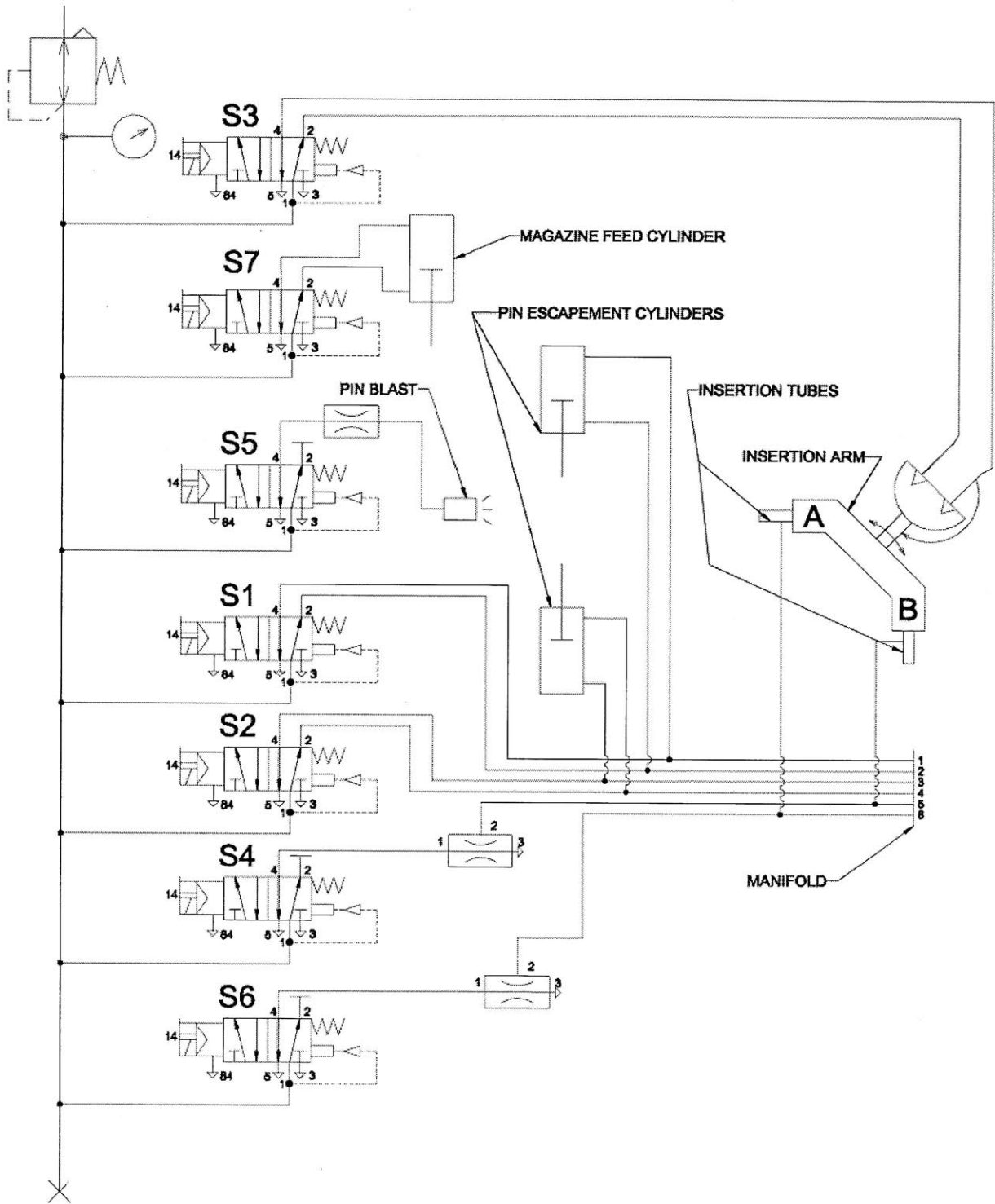

Figure 44 - Pneumatic schematic of the insertion head. See Appendix Figure 60 for a symbol legend.

The insertion arm is actuated by a SMC MSQB2A rotary actuator (see Figure 45). This actuator operates by means of two pistons attached to rack gears that spin the central pinion – thus producing the desired rotational motion (Figure 46).

The two adjusting screws on the side of the actuator adjust the rotational stroke of the actuator. In this case, the stroke is 180 degrees exactly, but the actuator is capable of rotations anywhere from 0 to 190 degrees. [29]

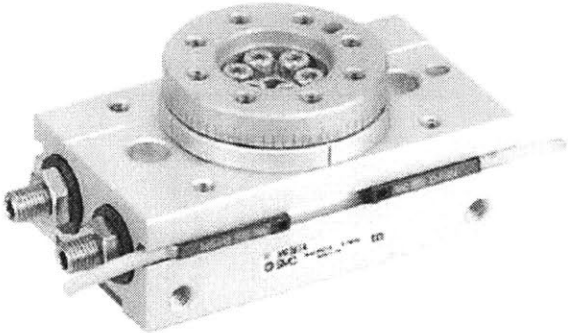

Figure 45 - SMC MSQB2A pneumatic rotary actuator [29]

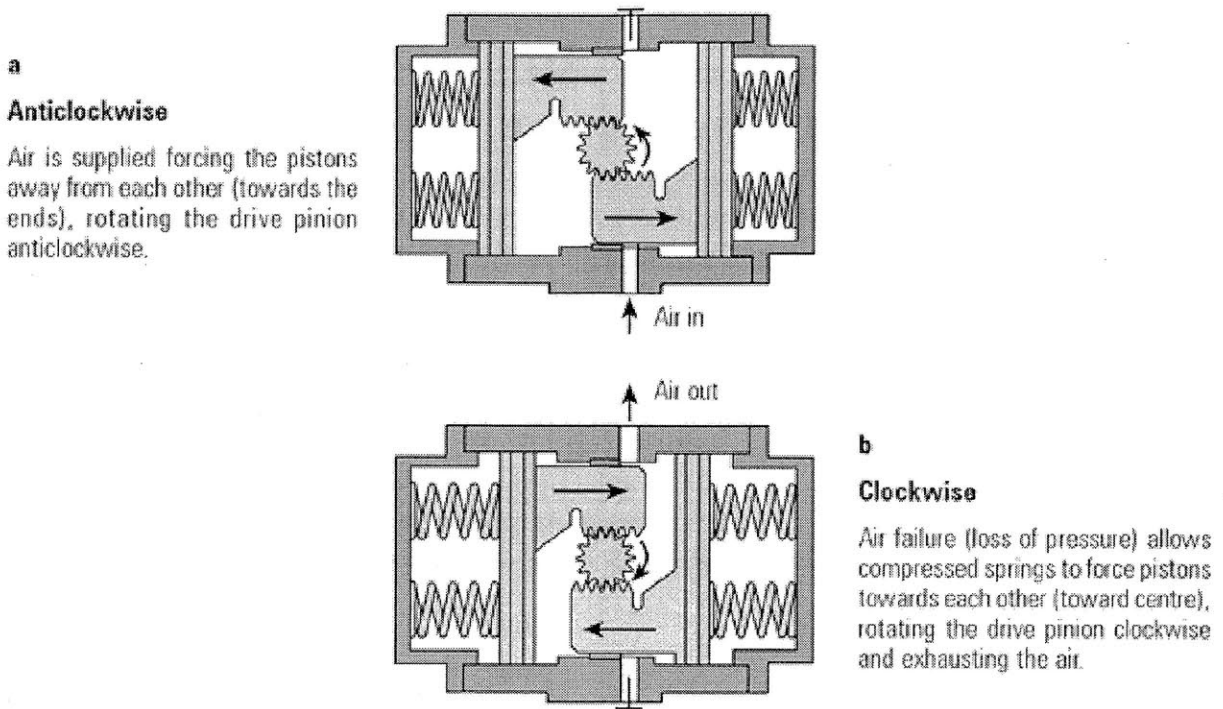

Figure 46 - Internal mechanism of pneumatic rotary actuator [30]

Vacuum is generated in the insertion tubes through the use of two FESTO VAD-1/8 Vacuum Generators (Figure 47). These devices generate negative (vacuum) pressure from positive pressure by means of a Venturi Tube. [31]

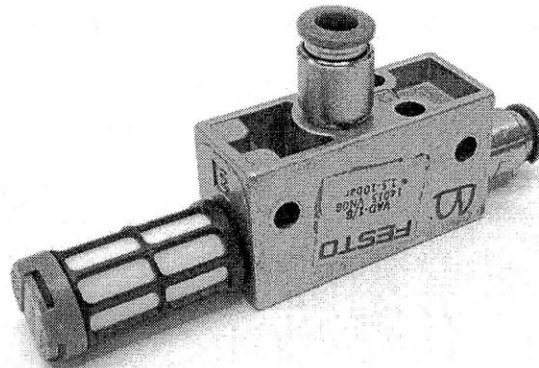

Figure 47 – Festo VAD-1/8 vacuum generator. The two inline ports are the pressure input and exhaust. The port on the tee is the vacuum generated. The vacuum generator is shown with a muffler to suppress exhaust noise.

6.2.3 Insertion Arm Bearing Arrangement

The insertion arm holds the insertion tubes in both the horizontal position to pick up a new pin, and the vertical position to press a pin into a PCB. During pin pressing, the insertion arm must support forces acting in the vertical direction. These forces resolve to axial and normal forces on the rotational shaft that the insertion arm revolves around. As such, a proper bearing arrangement that supported this load must be designed (Figure 48).

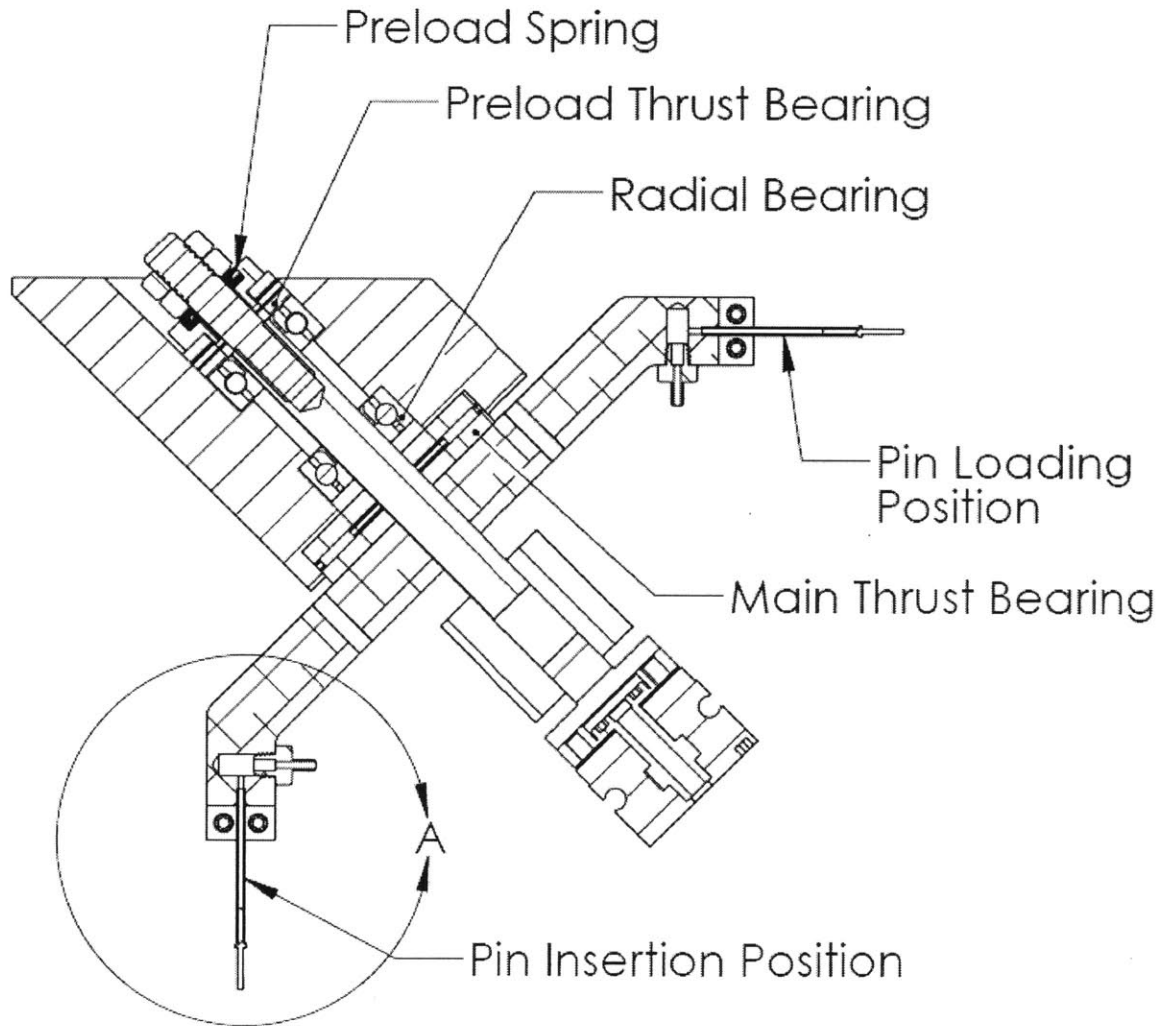

Figure 48 - General layout of bearings in the insertion head

The chosen bearing arrangement consists of two radial ball bearings, one main needle roller thrust bearing, and a smaller ball thrust bearing and a preload spring. The dimensions of the layout are shown in Figure 51.

The insertion forces are supported by the two radial ball bearings and the thrust needle bearing. The smaller ball thrust bearing serves as a preload bearing to allow the preload spring to spin with the insertion arm. As such, the ball thrust bearing must only support the preload force from the spring (see Figure 50), and not any forces from pin insertion.

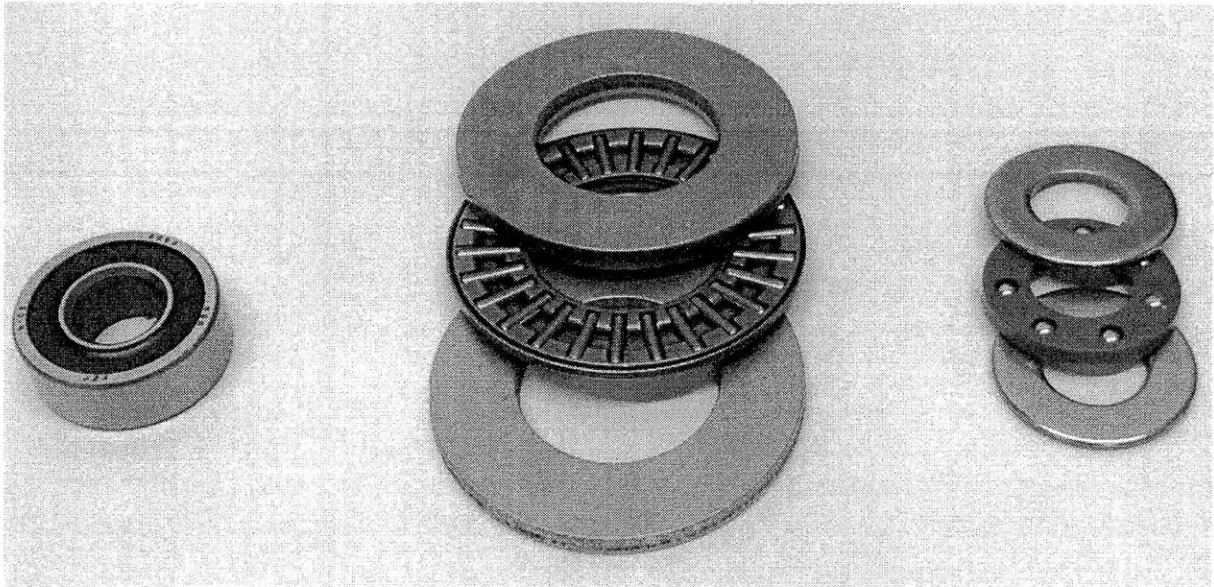

Figure 49 – The bearings used in the insertion head. Radial ball bearing (left); main needle roller thrust bearing (middle); and preload ball roller thrust bearing (right).

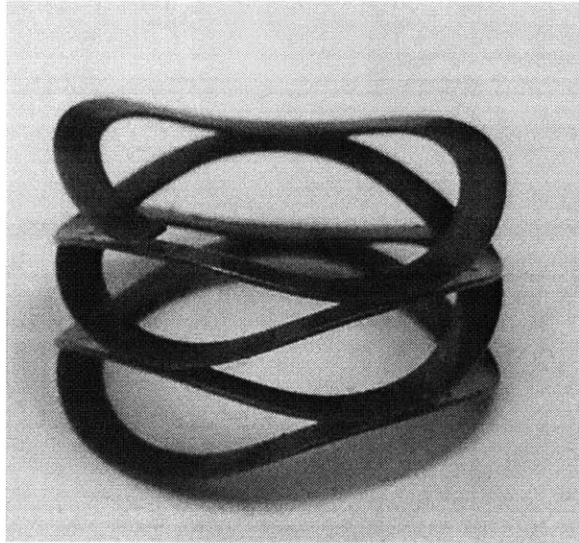

Figure 50 - Wave spring used to preload thrust bearing. Smalley Steel Ring Co. Model C056-L2.

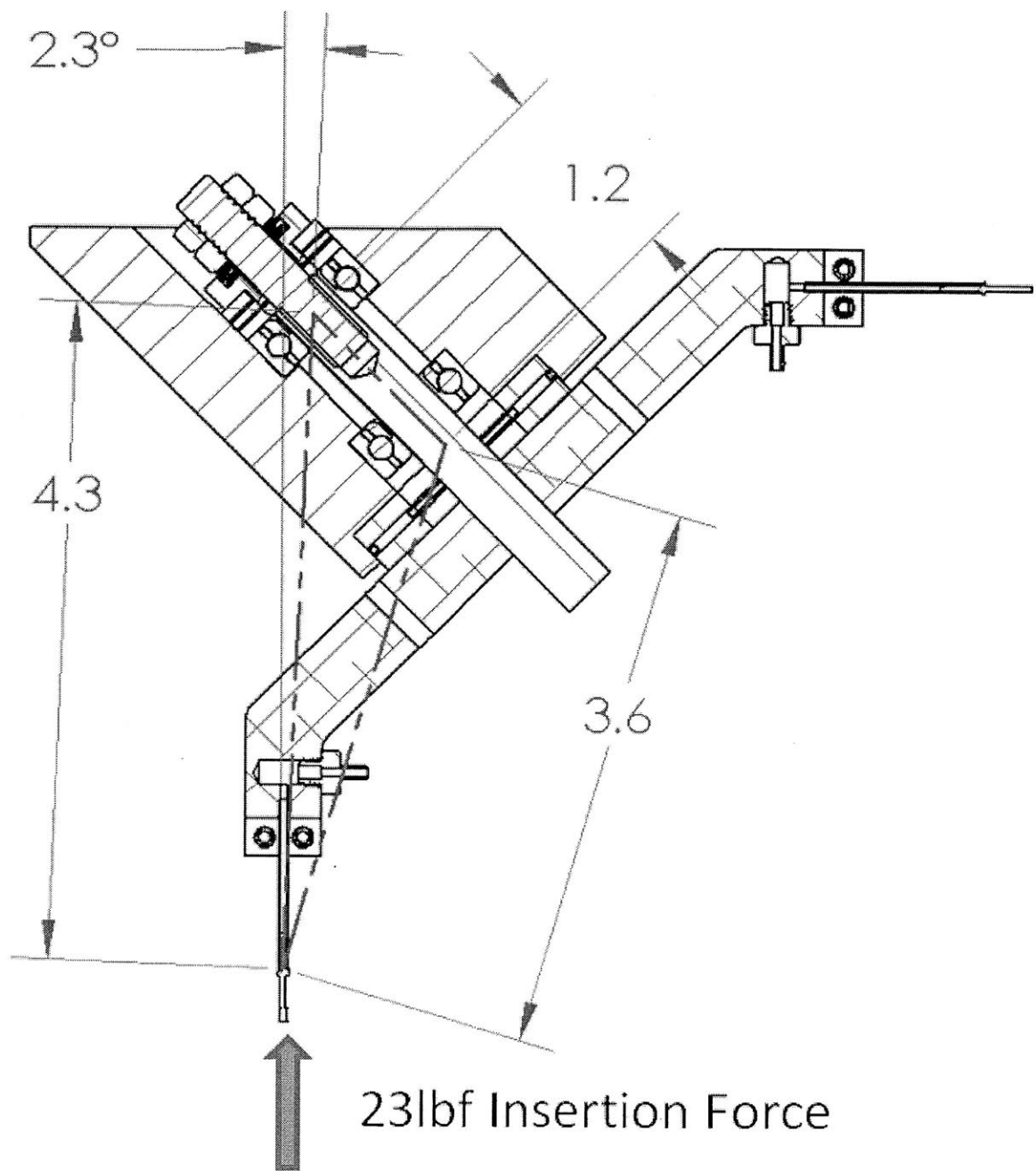

Figure 51 – Dimensioned layout of bearing arrangement in the insertion head
 The bearings chosen for the design are listed in Table 1 along with their load capacities.

Table 1 - Insertion head bearing specifications

Bearing	Model	Dimensions	Dynamic Load Capacity, C_D , <i>lbf</i>	Minimum L_{10} Life expectancy ¹ , hours
Thrust Needle Bearing	INA TC1427	1-5/8" OD x 7/8" ID x 5/16" THK	4400	7.12x10 ⁹
Radial Ball Bearings	NICE 3004DCTNTG18	7/8" OD x 3/8" ID x 1/4" THK	325	2.7x10 ⁵
Thrust Ball Bearing	TIMKEN 20206 TBS-043	7/8" OD x 7/16" ID x 1/4" THK	50	1.08x10 ⁵

The forces on each bearing can be found through a simple force and moment balance. Referring to Figure 51, we can create a diagram of the forces acting on each bearing:

¹ L_{10} life is equivalent to the number of hours that 90% of a group of the same bearings can be expected to run at a certain load and speed before symptoms of mechanical fatigue set in. [33]

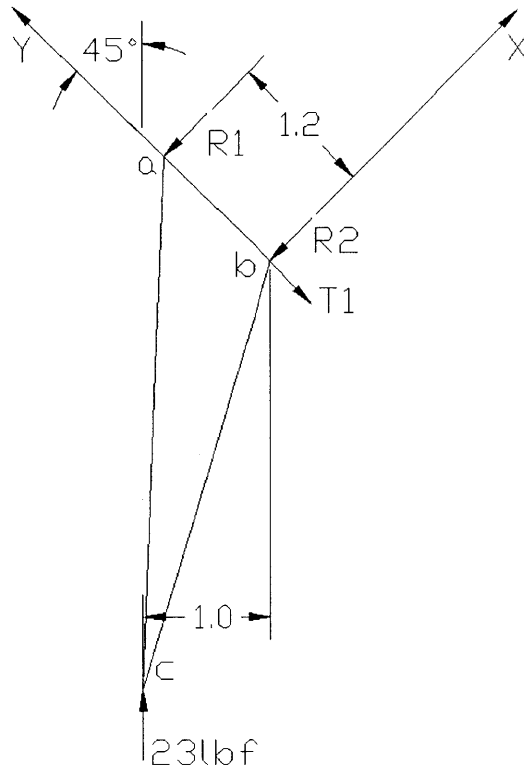

Figure 52 - Free body diagram of the insertion forces acting on the insertion arm bearings
 A moment balance about point b yields (CCW is positive):

$$\sum M_b = -1(23lbf) + 1.2R_1 = 0 \quad [6-5]$$

$$R_1 = 19.16lbf \quad [6-6]$$

Summing the forces in the X direction:

$$\sum F_x = -R_1 - R_2 + 23lbf * \cos(45) = 0 \quad [6-7]$$

$$R_2 = -2.90lbf \quad [6-8]$$

And, finally, summing the forces in the Y direction:

$$\sum F_y = -T_1 + 23\text{ lbf} * \sin(45) = 0 \quad [6-9]$$

$$T_1 = 16.26\text{ lbf} \quad [6-10]$$

Next, the rotational speed of the insertion arm (and, subsequently the bearings) must be found. The insertion arm is allotted 100ms to rotate 180 degrees between the pin pickup position and the pin insertion position. Thus,

$$\frac{\frac{1}{2} \text{ Revolution}}{0.1 \text{ Seconds}} = 5 \frac{\text{ revolutions}}{\text{ Second}} = 300 \text{ RPM} \quad [6-11]$$

The general formula for L_{10} bearing life for ball bearings is [32]:

$$L_{10} = \left(\frac{C_D}{P}\right)^3 * 10^6 \quad [6-12]$$

Where,

$$C_D = \text{Dynamic Load Capacity, lbf}$$

$$P = \text{Radial Bearing Load}$$

The two radial ball bearings, R_1 and R_2 , have loads with magnitudes of 2.90 lbf and 19.16 lbf, respectively. The dynamic load capacity, C_D , can be found in Table 1. This yields L_{10} life expectancies of:

For R_1 :

$$L_{10} = 1.4 \times 10^{12} \text{ revolutions} \quad [6-13]$$

At 300 RPM, this is equivalent to:

$$L_{10} = 1.4 \times 10^{12} \text{ revolutions} * \frac{1 \text{ minutes}}{300 \text{ revolution}} * \frac{1 \text{ hours}}{60 \text{ minute}} \quad [6-14]$$

$$L_{10} = 7.78 \times 10^7 \text{ hours} \quad [6-15]$$

And, similarly, for R₂:

$$L_{10} = 4.88 \times 10^9 \text{ revolutions} \quad [6-16]$$

Or, in hours:

$$L_{10} = 2.7 \times 10^5 \text{ hours} \quad [6-17]$$

For roller bearings (needle roller bearings, in this case), the general formula for L₁₀ life is modified to:

$$L_{10} = \left(\frac{C_D}{P} \right)^{\frac{10}{3}} * 10^6 \quad [6-18]$$

For the main thrust bearing, this yields a L₁₀ life of:

$$L_{10} = 7.12 \times 10^9 \text{ hours} \quad [6-19]$$

The preload spring applies a force in the Y direction to keep the main thrust bearing loaded even when the insertion force is not acting on the insertion arm. The force in the spring must counteract the force due to gravity that is pulling the insertion arm in the negative Y direction. In this case, 4 pounds of preload force is sufficient, and is generated by means of the wave-spring preload spring at the end of the rotating shaft on the insertion arm. The weight of the insertion arm and rotational shaft is approximately 1lb. The preload force of 4lb is enough to overcome this weight, and provide sufficient force to keep the main thrust bearing in contact with the bearing races.

With 4lbf of thrust load, the L₁₀ life of the preload thrust bearing is:

$$L_{10} = 1.08 \times 10^5 \text{ hours} \quad [6-20]$$

Chapter 7. Testing

The insertion head prototype developed in this thesis was tested in order to determine its performance respective to the original design specifications. Target values for the insertion head were a cycle time of one second, and a mean time to failure (MTTF) of approximately 4 hours.

7.1 Testing Methodology

7.1.1 Mean Time to Failure

To test the performance of the insertion head and magazine, the control program [2] was run continuously with a full magazine of pins. The magazine was replenished as required while the program was paused in order to continue the test.

The number of failures was tallied and the type of failure was also recorded. In total, 1700 pins were run through the system.

The types of failures are characterized by two major categories:

- Misfeed (non-critical), and
- Pin jam (critical).

Critical failures cause the mechanism to jam, and halt the machine from proceeding to process pins. Non-critical failures simply misfeed, or lose grip of a pin but do not prevent the insertion head from processing additional pins. These failure characterizations are described in more detail in Section 7.3.

In total, to achieve a MTTF of 4 hours, the probability of failure needs to be less than 0.0069%.

This value is determined by looking at the number of failure opportunities there are in 4 hours. In 4 hours 14,400 pins are pressed into PCBs given a cycle time of 2 seconds and two gantries operating simultaneously. In order to only require operator attention once every four hours, the insertion head can only fail once per every 14,400 pins pressed, or 0.0069% of the time.

7.1.2 Cycle Time

The control program that controls the timing of all of the actuators and valves in the insertion head operates with certain specified delays between each step of the process. These delays can be decreased on the fly during testing in order to minimize cycle time.

The procedure for minimizing cycle time was to reduce the delay values in each step of the process incrementally until the machine started performing undesirably. Undesirable behavior during cycle time reduction included:

- Failing to feed pin from magazine pin stack;
- Failure to eject pin from magazine to insertion head;
- Pin jamming as a result of a collision with the pin escapement; and
- Pin being ejected from the insertion tube during the insertion arm rotation.

7.2 Testing Results

7.2.1 Mean Time to Failure

The machine failed critically 2 times during the 1700 pins that were run during testing. This works out to a failure probability of 0.12%. Additionally, during the same testing, 20 non-critical failures were observed, representing a failure probability of 1.12%.

With a throughput of one pin per second, the MTTF for critical failures works out to:

$$\frac{2 \text{ critical failures}}{1700 \text{ pin}} * 1 \frac{\text{pin}}{\text{second}} = \frac{1 \text{ critical failures}}{850 \text{ second}} \quad [7-1]$$

$$MTTF = \frac{850 \text{ seconds}}{1 \text{ critical failure}} = 0.24 \text{ hours} \quad [7-2]$$

The critical failures observed occurred when galling (see Section 7.3.1.2) caused the feeder slide to seize, and when the hard stops (see Section 7.3.1.4) drifted and caused misalignment. After these problems were addressed (within the first 8 runs out of 24 total), they were not observed again.

7.2.2 Cycle Time

The final cycle time after optimizing the delay values in the control program was 1.1 seconds pin to pin including a 250ms delay to allow the pin to drop out of the insertion tube after being brought to the insertion orientation. Thus, the realistic cycle time, represented by the amount of time after the insertion head is instructed to feed another pin and when the pin is ready to be pressed into a PCB is actually 850ms.

This is 85% of the target cycle time which allows time for the robot to perform the task of positioning and pressing the pin while still maintaining the one pin per second throughput rate. With two gantries operating on the positioning robot and a throughput rate per gantry of one pin every two seconds, an 850ms cycle time leaves 1.15 seconds for the robot to move to the next hole to be pinned.

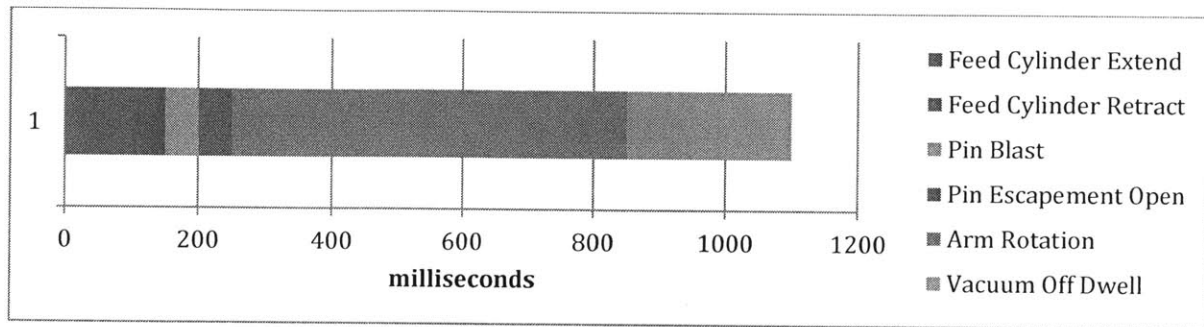

Figure 53 – Cycle time shown broken down into each event that occurs while orienting a pin for insertion.

Figure 53 shows the events that are occurring during the pinning process on a timeline scale. By far the largest portion of the cycle is consumed by rotating the insertion arm (approximately 600ms). This presents opportunity to reduce cycle time by reducing the weight or the inertia of the insertion arm and shaft to allow for a faster rotation. Decreasing the radius that the insertion arm rotates on will also decrease the effective inertia, which will result in a faster swing speed.

7.3 Failure Characterizations

This section characterizes the machine failures that were observed during building and testing the insertion head and magazine. Not all of the failures were observed during the official testing phase outlined in the Testing Methodology section (7.1), but they were encountered during the prototype assembly stage.

7.3.1 Critical Failures

The critical failures observed during the build and test stage of the project included:

- Failure of a pin to exit the magazine;
- Galling between moving parts;
- Double-feeding pins to the insertion tube; and
- Drifting hard stops.

7.3.1.1 Failure of a Pin to Exit the Magazine

Pins can fail to exit the magazine due to a built up edge on the magazine feeder slide as a result of continuously trying to cycle the pin feeder with a pin jammed in the mechanism. Cycling the feeder slide with a pin stuck in the mechanism “breaks” the edge of the contour on the feeder slide and creates a burr which can cause the mechanism to seize.

This built up edge and burr can be prevented by machining the feeder slide out of a tougher metal, such as steel, to resist creating a broken corner from being cycled repeatedly.

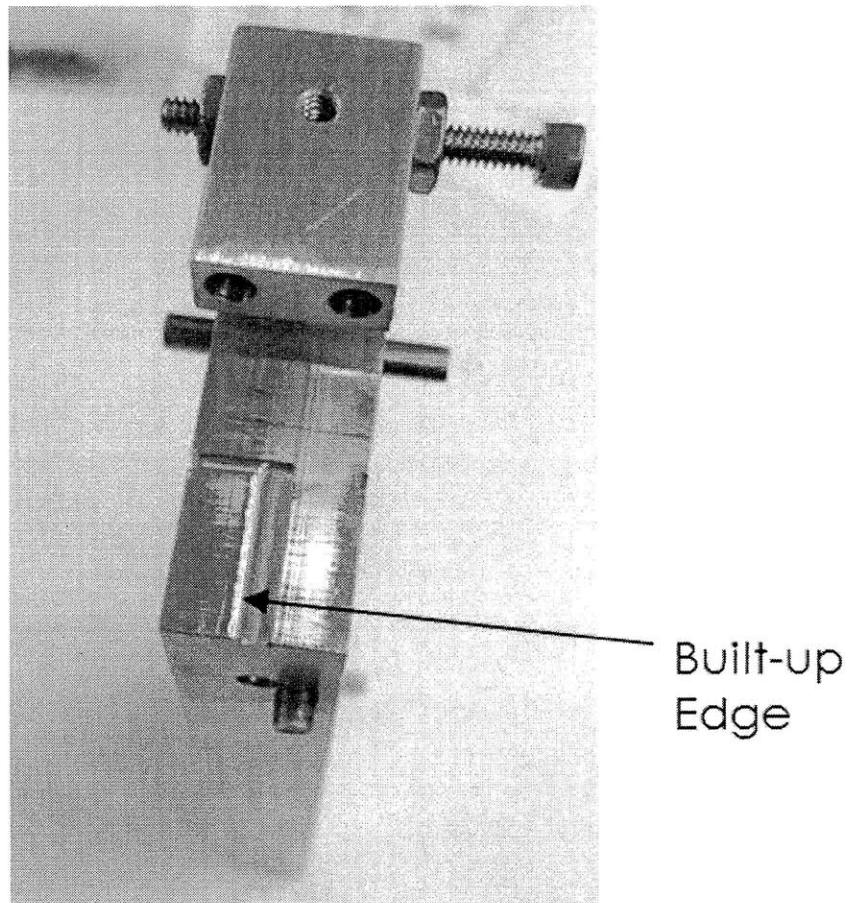

Figure 54 - Built up edge on the bottom of the magazine (feeder plate removed to show built up edge).

7.3.1.2 *Galling Between Moving Parts*

Galling between the feeder slide and other components of the magazine and insertion head is due to similar metals (Aluminum) rubbing against one another causing the slide to seize. Aluminum was used for the prototype because it is easy to machine, and was readily available at SynQor. For high-cycle testing, this problem needs to be addressed.

Galling can be prevented by designing moving components out of dissimilar metals that are designed to act as bearing surfaces. Metals such as cast iron and bronze are typically used for bearing surfaces and will help prevent galling with aluminum or steel.

For the prototype, galling was minimized by reducing surface contact area of any moving parts made out of similar metals. Most notably, the magazine feeder slide was machined to have a running clearance between the feeder slide and the insertion head – preventing metal to metal contact.

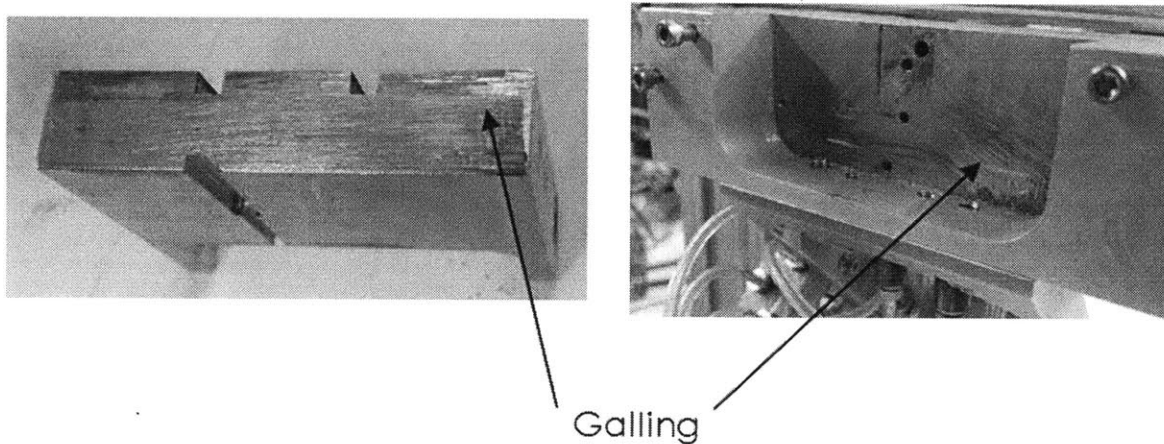

Figure 55 - Galling on the feeder slide plate (left) and the magazine mounting block (right).

7.3.1.3 *Double-Feeding pins*

The control program did not have an initialization sequence that cleared pins from the insertion head before beginning the pinning cycle. As a result, during testing if a pin was left in the insertion head and the control program was started, the machine could potentially jam.

This can be prevented by designing an initialization sequence into the control program that opens the pin gates, and turns on the air port behind the pin to clear any pins that may already be present in the insertion head.

7.3.1.4 Drifting Hard Stops

The hard stops that constrain the rotational motion of the insertion arm consist of two screws locked in place by a jam nut. Originally, these hard stops were M4 set screws with another set screw behind it to “lock” the hard stop in place. However, after repeatedly being loaded by the insertion arm impact, these M4 set screws would work loose and start to drift – causing the insertion arm to be misaligned to the pin escapement and causing the insertion head to jam

This problem was addressed by using larger M5 screws with a jam nut to provide more resistance to loosening during operation.

7.3.2 Non-Critical Failures

The only non-critical failure that was observed during testing was pins failing to seat themselves in the insertion tubes.

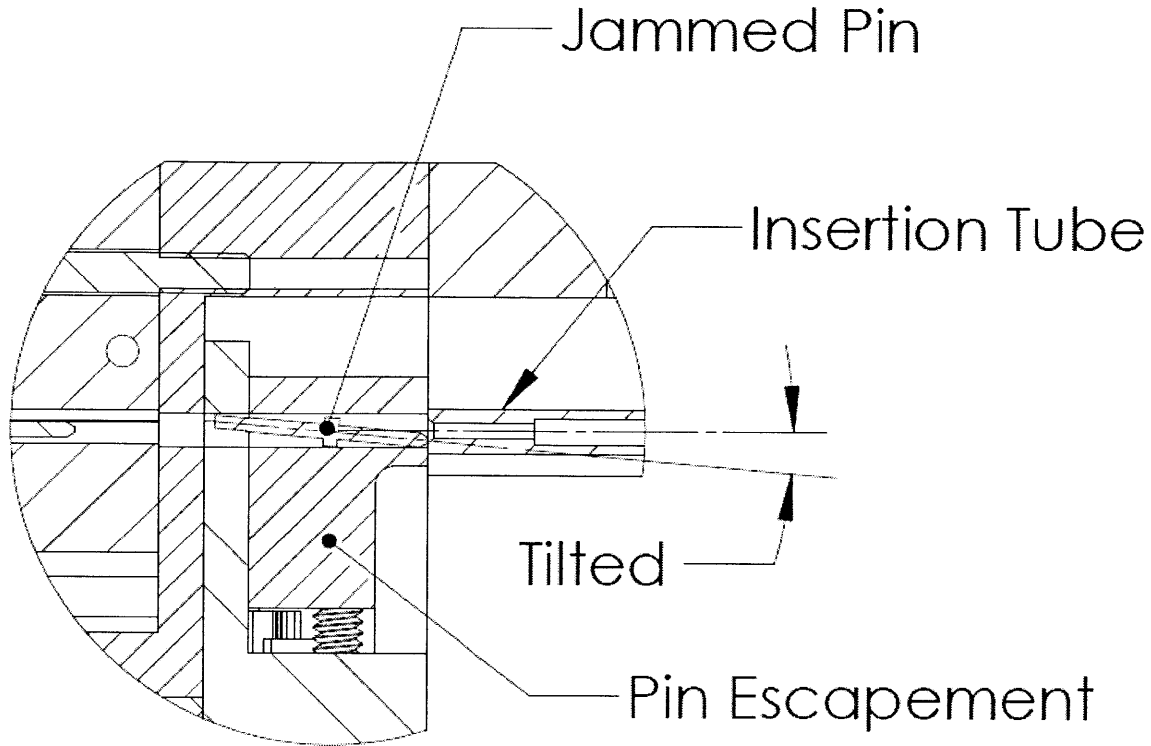

Figure 56 - Pin jammed at tip of insertion tube.

This fault was only observed to happen on one of the insertion tubes. Upon further investigation it was discovered that this insertion tube was slightly misaligned from the pin escapement – likely a result of manufacturing error.

This “shift” in the tube occasionally causes a pin to be “caught” on the face of the tube, unable to find its way into the insertion tube. The insertion head will attempt to feed another pin when this failure occurs. When another pin is fed towards the insertion tube, the first pin is “knocked” into place in the insertion tube and the second pin is ejected from the machine. Thus, one pin is wasted when this failure occurs. However, the machine does not jam and will continue to process pins. The tube was bent slightly to bring it in line with the pin escapement which reduced the frequency of this failure.

Chapter 8. Future Work

The pinning machine developed in this thesis is a prototype designed to demonstrate how pins can be stored and handled for insertion into a PCB. As such, this project lends itself to a second iteration that takes into account everything that has been learned as a result of designing this first round prototype. The design features that would be interesting to explore in future prototypes for the magazine and insertion head are outlined in this chapter. And, finally, overall system plans are proposed and a general outline of the work needed to be done to bring the system to production-ready status is discussed.

8.1 Magazine

The magazine, in its current state, is not able to be easily or automatically removed from the insertion head. A “quick coupling” method between the magazine and insertion head needs to be designed to allow the insertion head to change magazines automatically in the future.

In addition to the “quick coupling” between the magazine and insertion head, a method of actuating the magazine external to the magazine itself needs to be designed. The mechanism can consist of a simple air cylinder to slide the feeder plate side to side to feed pins in the magazine, but must be able to de-couple itself from the magazine when the insertion head calls for a new magazine.

The slide mechanism for the magazine consists of a dowel pin sliding in two SAE-841 bronze bushings. A more compact method for achieving this motion can be developed that will reduce the number of parts integral to the magazine (and thus, reducing the cost). Additionally, material selection should be taken into consideration to avoid the galling problems observed during testing. Moving parts should be made from some type of bearing material to prevent galling.

Experimentation with magazines with multiple pin tracks able to hold more pins could yield good results that would require less frequent magazine changes during the pinning cycle. Multiple position air cylinders can possibly be used for this application.

8.2 Insertion Head

The insertion head developed in this thesis has its current form as a result of testing a number of different magazines, actuation methods, and mechanisms integral to the insertion head. As such, there are a number of physical features on the insertion head that are not of use. Once a final

mechanism is decided upon, the design of the insertion head can be optimized to reduce weight, mechanism footprint, and part complexity.

The weight of the insertion arm plays a large role in how long the rotation of the insertion arm takes, as well as how long it takes for the insertion arm to settle after it has completed the rotation and hits the hard stops. Reducing the weight of the insertion arm may yield improved cycle time of the insertion head.

The insertion tubes on the insertion arm currently have a chamfer at the end of them to help in seating a pin in the tube. However, this reduces the area that the insertion tube comes into contact with the collar of the pin. For pin pressing, it is desirable to have the maximum contact area between the pin collar and insertion tube to distribute pressing forces across the largest area on the collar of the pin. In order to eliminate the chamfer on the end of the insertion tubes, a chamfer can be added to the end of the pin escapement gates that would “funnel” the pin to the insertion tube. Once the gates opened, the vacuum pressure would then completely seat the pin in the insertion tube.

The rotary actuator is coupled to the insertion arm via a helical coupling which clamps on to the actuator and the insertion arm shaft via a “Fair-loc” style hub. This type of hub relies on the clamping force of the screw in each end of the coupling to create enough friction between the shaft and coupling to prevent spinning the shaft within the coupling. When no flow control is used on the arm rotation, the coupling can start to slip and cause misalignment in the system. A better solution would be to use a coupling with set screws that sit on wrench flats on the shafts to prevent spinning out in the coupling.

8.3 Overall System Future Work

After the prototyping stage is completed, and the magazine and insertion head are performing as required, the insertion head must be designed to mount on the positioning robot. The mounting method should allow the insertion head to be changed automatically by the robot without operator intervention. This fits in with the long-term scope of bringing this prototype to a production-ready state.

Work that still needs to be completed in order for the insertion head to be ready for production use includes:

- Magazine storage rack. This will hold a certain number of magazines within the positioning robot's work envelope; enabling the robot to automatically load another magazine.
- Weight minimization of the insertion head and magazine. The weight of both assemblies (the insertion head and the magazine) needs to be minimized to allow the positioning robot to move as quickly as possible.
- Designing a quick-change coupling between the insertion head and the positioning robot to allow the robot to pick up different diameter tools as required by the product being processed at that moment
- Integration of the insertion head sensors and pneumatic circuit into the positioning robot also must be completed to allow the positioning robot to control the functioning of the insertion head and magazine.

Additionally, since the insertion head designed herein is a modular assembly, SynQor can also pursue adapting the insertion head to fit onto other positioning systems already in use in their production system.

Chapter 9. Conclusions

The pinning system developed in this thesis is the first step of a much larger development process to design a machine to pin PCBs in a production environment. The design described and analyzed herein represents progress towards this overall goal, and with some future development work can be used on SynQor's production line.

As it stands, the pinning cycle time of 850ms seconds between pinning events meets the original design specification (given that there will be two gantries operating simultaneously). However, the mean time to failure (MTTF) of 0.24 hours still requires development work in order to bring this value closer to the design specification MTTF of 4 hours.

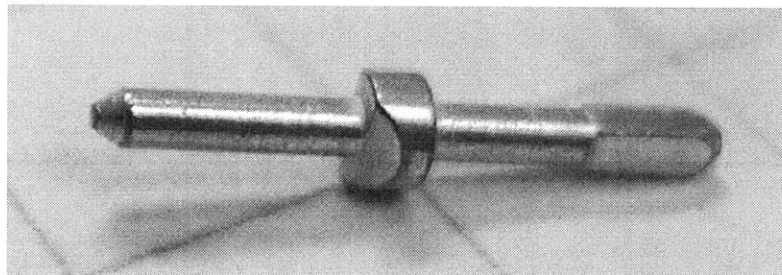

Chapter 10. Appendix

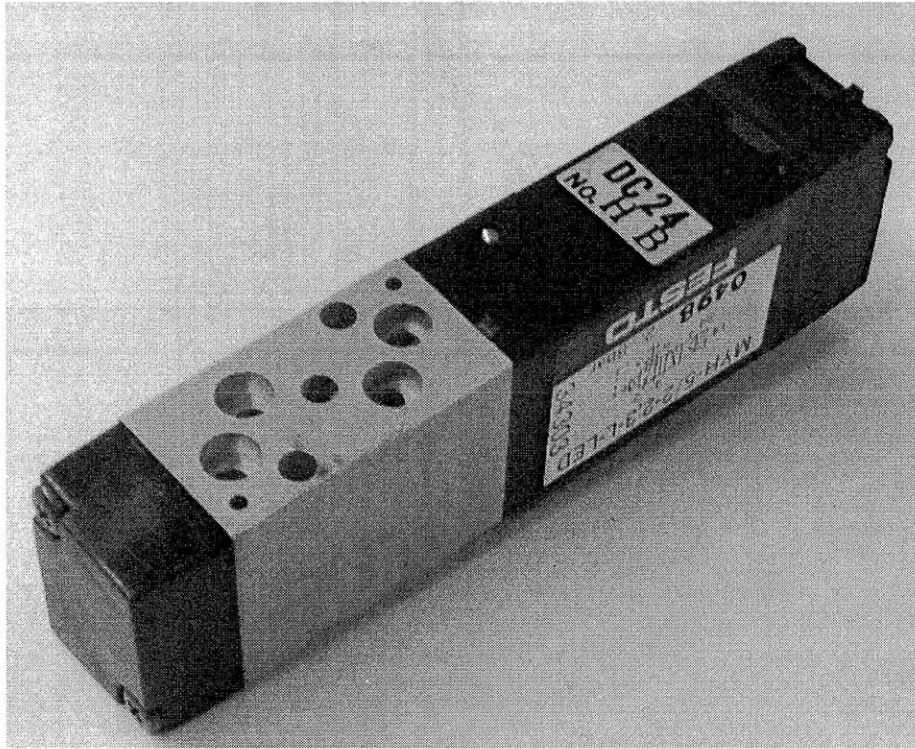

Figure 57 - Rear view of the solenoid valves used to control the actuators on the insertion head.



Figure 58 - Bimba Mead MA-250x0.25DA-RB double acting miniature air cylinders with two jam-nuts used for mounting.

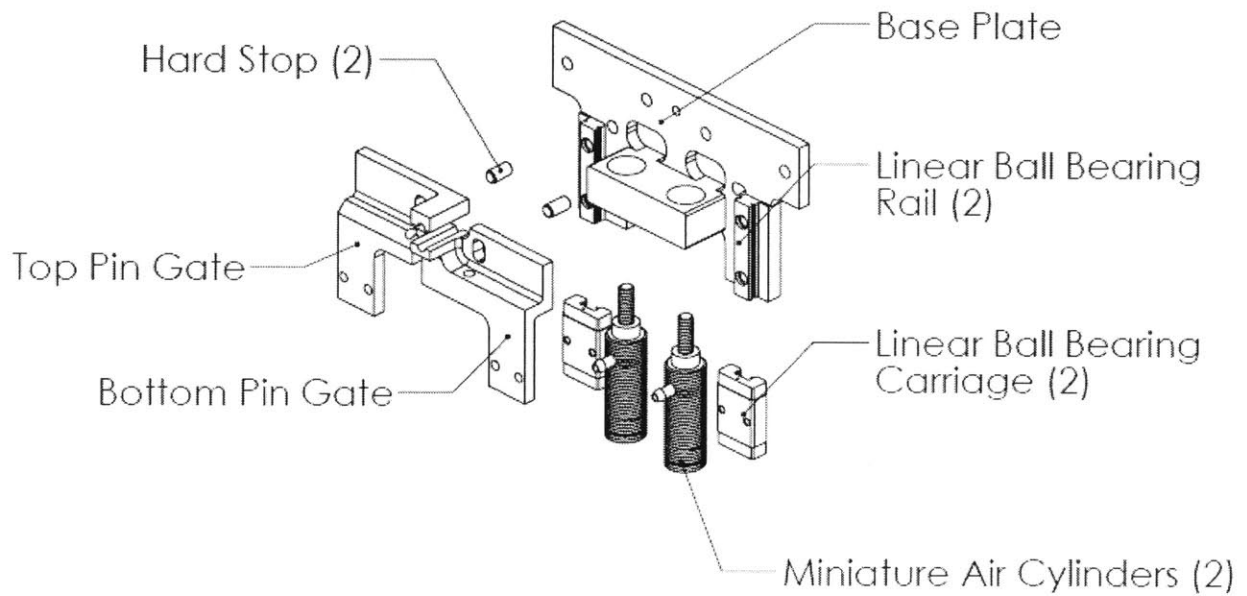
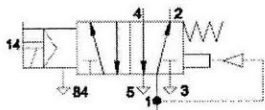

Figure 59 - Exploded view of the pin escapement with labeled parts.



Solenoid Valve, 5/2 Way



Venturi Vacuum Generator



Double-Acting Cylinder



Air Port (Open Fitting)

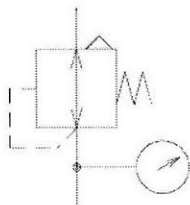

Pressure Regulator

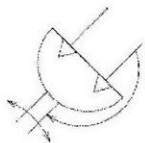

Rotary Actuator

Figure 60 - Symbol legend for pneumatic schematic, Figure 44.

Chapter 11. Bibliography

- [1] M. S. Chang, "Design of an Automated Sorting and Orienting Machine for Electronic Pins".
- [2] R. Isaac, "Development of Control System to Automate the PCB Pin Insertion Process".
- [3] "PCB Pins and Receptacles Information," GlobalSpec. [Online]. [Accessed 18 June 2012].
- [4] "PCB Pins and Receptacles Information," GlobalSpec, [Online]. Available: http://www.globalspec.com/learnmore/wire_connectors_interconnects/ic_interconnect_components/pcb_pins_receptacles. [Accessed 18 June 2012].
- [5] P. F. Ostwald and M. Jairo, *Manufacturing Processes and Systems* (9th Edition), John Wiley & Sons, 1997.
- [6] "Automation," Wikipedia, [Online]. Available: <http://en.wikipedia.org/wiki/Automation>. [Accessed 19 June 2012].
- [7] "Numerical Control," Wikipedia, [Online]. Available: http://en.wikipedia.org/wiki/Numerical_Control. [Accessed 19 June 2012].
- [8] M. P. Groover, *Automation, Production Systems, and Computer-Integrated Manufacturing*, Upper Saddle River: Pearson Education Inc., 2008.
- [9] Epson Robotics, "LS-Series SCARA Robots," [Online]. Available: <http://www.robots.epson.com/products/ls-series.htm>. [Accessed 23 June 2012].
- [10] Adept Robotics, "Adept Viper 6-Axis Robots," [Online]. Available: <http://www.adept.com/products/robots/6-axis/viper-s650/general>. [Accessed 22 June 2012].
- [11] "Olympus Technologies," [Online]. Available: <http://www.olympustechnologies.co.uk/>. [Accessed 21 June 2012].
- [12] C. Brecher, *Robot Control and Programming*, Aachen, Nordrhein Westfalen: Machine Tools Laboratory (WZL), 2010.
- [13] "United Nations Economic Commission for Europe," 30 October 2001. [Online]. Available: <http://www.unece.org/press/pr2001/01stat10e.html>. [Accessed 23 June 2012].
- [14] Hardware Secrets, "How Gigabit Ethernet Works," [Online]. Available: <http://www.hardwaresecrets.com/article/How-Gigabit-Ethernet-Works/231/3>.
- [15] Cognex, Inc., "In-Sight 500 Vision System," [Online]. Available: <http://www.cognex.com/IS500/>.

- [16] Cognex, Inc., "In-Sight Micro Vision Systems," [Online]. Available: <http://www.cognex.com/in-sight-micro-vision-systems.aspx>.
- [17] Keyence, Inc., "Ultra High-Speed, Flexible Image Processing System," Keyence, Inc..
- [18] ControlDesign.com, "Machine-Vision Market Stays Strong," [Online]. Available: <http://www.controldesign.com/articles/2006/078.html>.
- [19] Cognex, Inc., "Industrial Sensors: Checker," [Online]. Available: <http://www.cognex.com/industrial-sensor-checker.aspx>.
- [20] National Instruments, Inc., "Building a Real-Time System with NI Hardware and Software," [Online]. Available: <http://www.ni.com/white-paper/4040/en>.
- [21] W. Hardin, "Vision-Guided Robotics Responds to Changes in Photovoltaic Manufacturing," 8 September 2010. [Online]. Available: http://www.visiononline.org/vision-resources-details.cfm?content_id=2247.
- [22] Cognex, Inc., "New 3D Vision - Not Just any 3D, It's Cognex 3D!," 3 May 2011. [Online]. Available: <http://www.cognex.com/CognexInfo/PressReleases/PressRelease.aspx?id=8577>.
- [23] Adept Inc., "Adept Quattro Parallel Robots," [Online]. Available: <http://www.adept.com/products/robots/parallel/quattro-s650h/general>.
- [24] International Federation of Robotics, "History," [Online]. Available: <http://www.ifr.org/history/>. [Accessed 22 June 2012].
- [25] Rixan Associates, Inc., "Automatic Screwdriver Robot," [Online]. Available: <http://www.rixan.com/Products2/tabid/64/CategoryID/11/List/1/Level/1/ProductID/85/Default.aspx?SortField=DateCreated%2CDateCreated+DESC>. [Accessed 22 June 2012].
- [26] PushCorp, Inc., "Success Stories," [Online]. Available: <http://www.pushcorp.com/success.htm>. [Accessed 23 June 2012].
- [27] Schunk GmbH & Co., "Automation," [Online]. Available: http://www.schunk.com/schunk/schunk_websites/products/products_level_1_overview_typ4.html?product_level_1=244&product_level_2=0&product_level_3=0&country=INT&lngCode=EN&lngCode2=EN.
- [28] T. R. Kurfess, "Robotics and Automation Handbook," New York, CRC Press, 2005, pp. 215 - 233.
- [29] SMC Corporation of America, "Pneumatic Rotary Actuator Series MSQ," [Online]. Available: <http://www.smcusa.com/productsearchresults.aspx?xmlnum=20183&partnumber=msqb1a>.

- [30] Spirax Sarco, "Control Valve Actuators and Positioners," [Online]. Available: <http://www.spiraxsarco.com/resources/steam-engineering-tutorials/control-hardware-el-pn-actuation/control-valve-actuators-and-positioners.asp>.
- [31] Wikipedia, "Venturi Effect," [Online]. Available: http://en.wikipedia.org/wiki/Venturi_effect.
- [32] J. A. Collins, Mechanical Design of Machine Elements and Machines, John Wiley & Sons, Inc., 2003.
- [33] Pacamor Kubar Bearings, "Bearing Life Estimation Formulas," [Online]. Available: <http://www.pacamor.com/technical/lifeandload.php>.

Chapter 12. Bill of Materials

Item No.	Part Number	QTY	Description	Vendor	MFG Part No
1	H100	1	Insertion Head Assembly		
1.1	H101	1	Chassis		
1.1.1	H102	1	Support plate		
1.1.2	H103	2	Support Bracket		
1.1.3	H104	1	Magazine Mounting Block		
1.1.4		6	SHCS, #6-32 x 1-5/8" LG		
1.1.5		6	FHS, #6-32 x 1/2" LG		
1.2	H105	1	Insertion Arm Assembly		
1.2.1	H106	1	Bearing Block		
1.2.2	H107	1	Insertion Arm Shaft		
1.2.3		2	Radial ball bearing, 7/8" OD x 3/8" ID x 1/4" THK	NICE	3004DCTNTG18
1.2.4		1	Needle Thrust Bearing, 1-5/8" OD x 7/8" ID x 5/16" THK	INA	TC1427
1.2.5		1	Ball Thrust Bearing, 7/8" OD x 7/16" ID x 1/4" THK	TIMKEN	20206 TBS-043
1.2.6	H108	1	Bearing Preload Cap		
1.2.7		1	Set Screw, 5/16-18 x 1-1/2" LG, Cup Point		
1.2.8		1	Wave Spring, Smalley, 5lb load, 1/8" work height, 9/16" OD	SMALLEY STEEL RING CO.	C056-L2
1.2.9		2	Jam Nut, 5/16-18		
1.2.10		2	Dowel Pin, 1/8" DIA x 3/8" LG		
1.2.11	H109	1	Insertion Arm Part		
1.2.12		2	Set Screw, #10-32 x 1/4" LG, Cup Point		
1.2.13		4	SHCS, #2-56 x 1/2" LG		
1.2.14	H110	2	Insertion Tube		
1.3	H111	1	Pin Escapement		
1.3.1	H112	1	Top Gate		
1.3.2	H113	1	Bottom Gate		

1.3.3		2	Linear Ball Bearing Slide, 5mm rail & carriage	NIPPON THOMPSON CO.	101025 (RAIL) ML5C1PS2 (CARRIAGE)
1.3.4		4	SHCS, M2 x 5mm LG		
1.3.5		4	Pan Head Screw, M2 x 5mm LG		
1.3.6		2	Double-Acting miniature air cylinders, full body threaded	BIMBA-MEAD	MA-250X0.25-DA-RB
1.3.7		2	Dowel Pin, 1/8" DIA x 1/4" LG		
1.4		1	Rotary Actuator	SMC	MSQB2A
1.5	H114	1	Actuator Swivel Attachment		
1.6		1	Helical Coupling, 3/8" Bore x 1" LG	McMaster	6208K471
1.7		2	SHCS, M3 x 10mm		
1.15		8	FHS, #6-32 x 1/2" LG		
1.16		2	1/8 x 1/2" dowel pin		
1.17		2	Dowel Pin, 1/8" DIA x 1/4" LG		
1.18		2	BHCS, #4-40 x 1/4" LG		
1.19		4	BHCS, M3 x 6mm LG		
1.20	H115	1	Cylinder Mount Plate		
1.21		6	SHCS, #6-32 x 1/2" LG		
1.22	H116	1	Actuator Mount Bracket		
1.23	H117	1	Magazine Cylinder Coupling		
1.2.4	H118	2	Hard Stop		
2	M100	1	Magazine Assembly		
2.1	M101	1	Magazine Spine Plate		
2.2	M102	2	Magazine Side Plate		
2.3	M103		Magazine Feeder Slide		
2.3		4	Dowel Pin, 1/8" DIA x 3/8" LG		
2.4		2	Bushing, 1/8" Shaft DIA, 1/4" OD, 1/8" LG		
2.5		12	SHCS, #4-40 x 3/8" LG		
2.6		1	Dowel Pin, 1/8" DIA x 2" LG		
2.7		6	Set Screw, #4-40 x 1/4" LG, Cup Point		
2.8		2	Dowel Pin, 1/8" DIA x 3/8" LG		

Chapter 13. Engineering Drawings

This section serves to document the parts and assemblies that were created in the process of prototyping the insertion head.

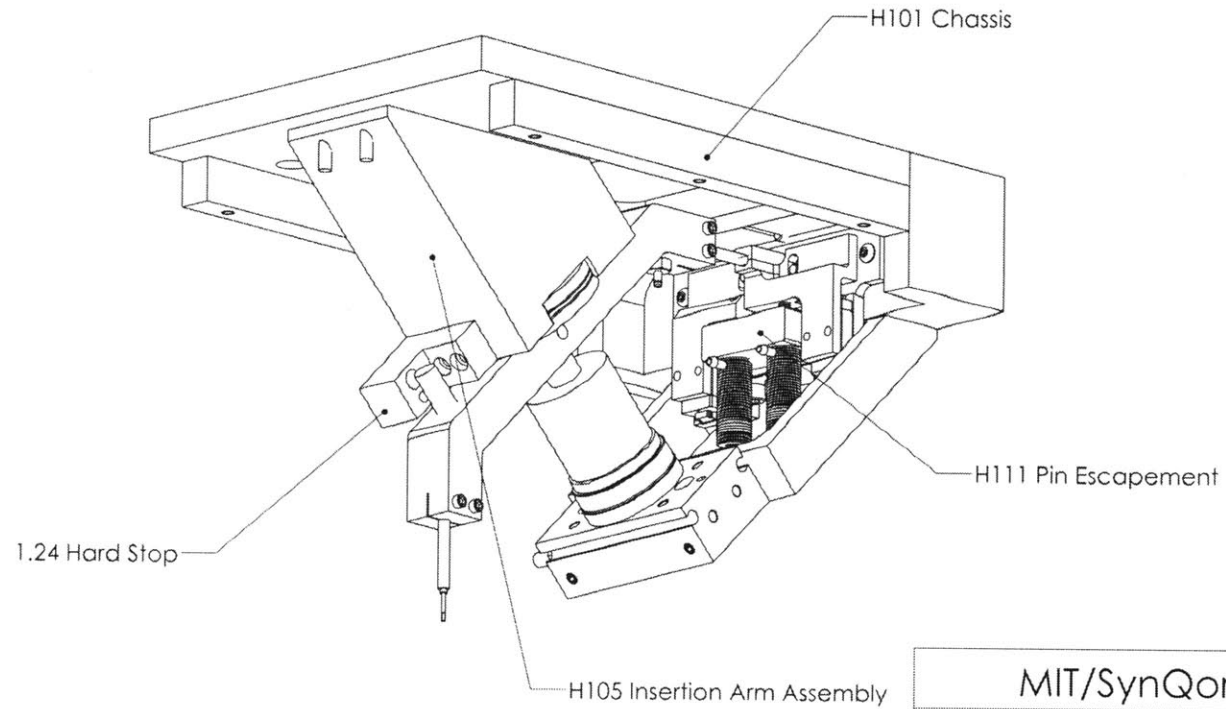

MIT/SynQor		
TITLE: Insertion Head Assembly		
SIZE	DWG. NO.	REV
A	H100	
SCALE: 1:2	WEIGHT:	SHEET 1 OF 1

SolidWorks Student License
Academic Use Only

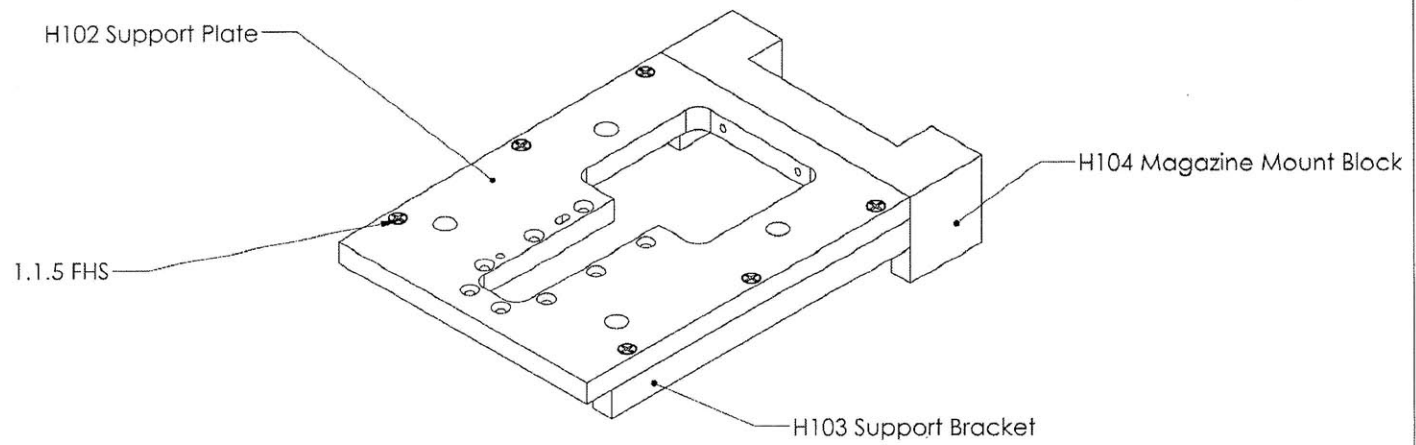

MIT/SynQor		
TITLE: Chassis Assembly		
SIZE	DWG. NO.	REV
A	H101	
SCALE: 1:2	WEIGHT:	SHEET 1 OF 1

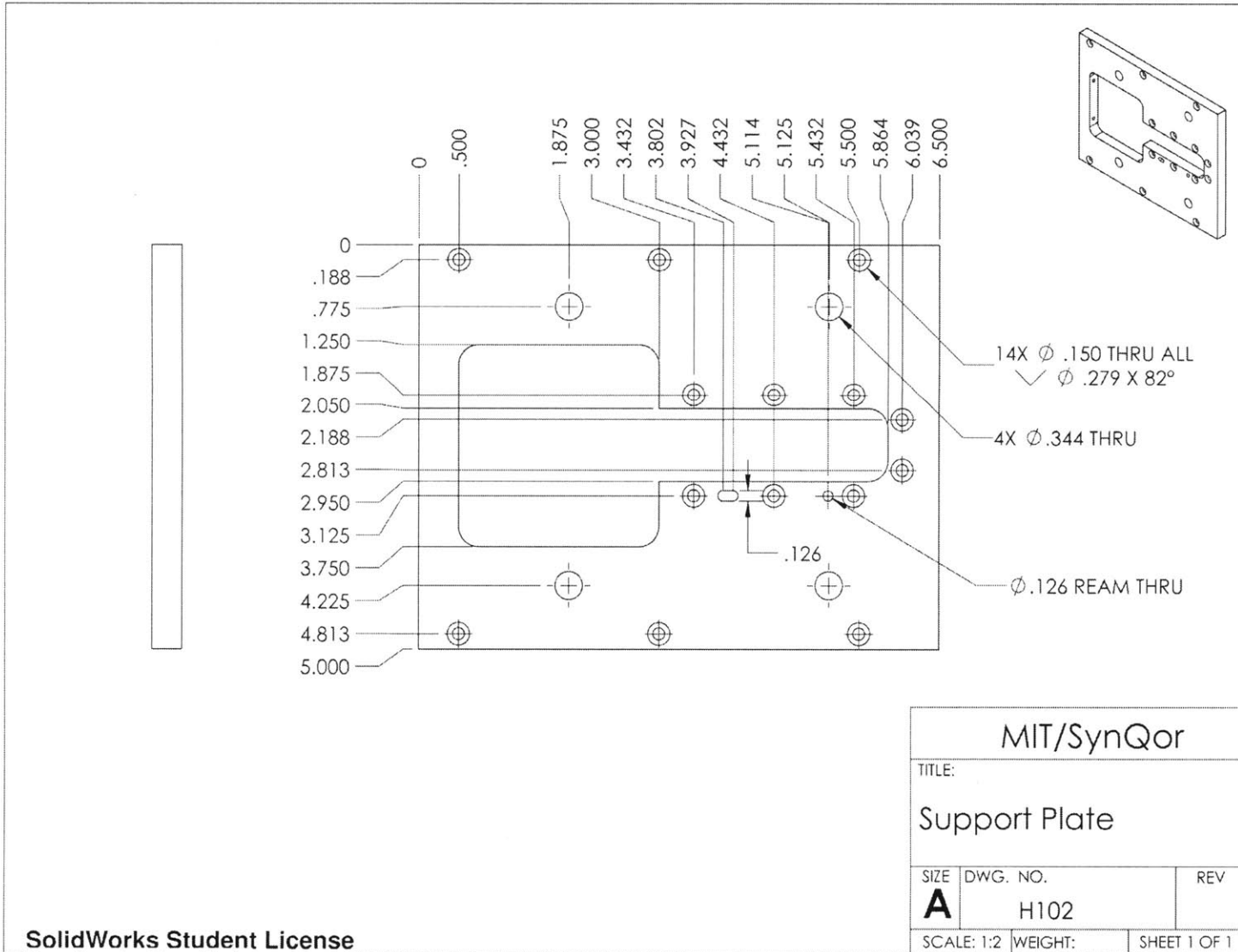

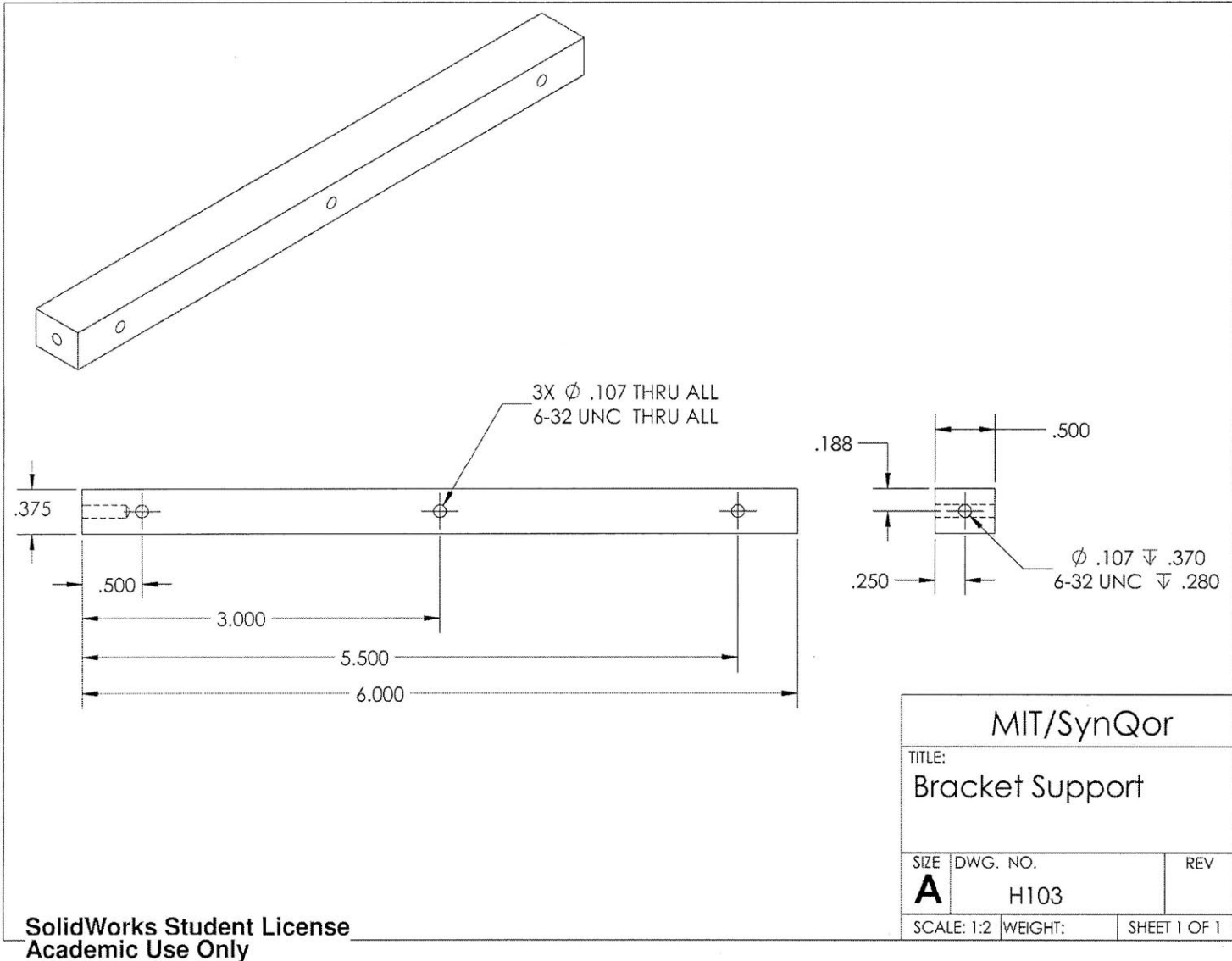

SolidWorks Student License
Academic Use Only

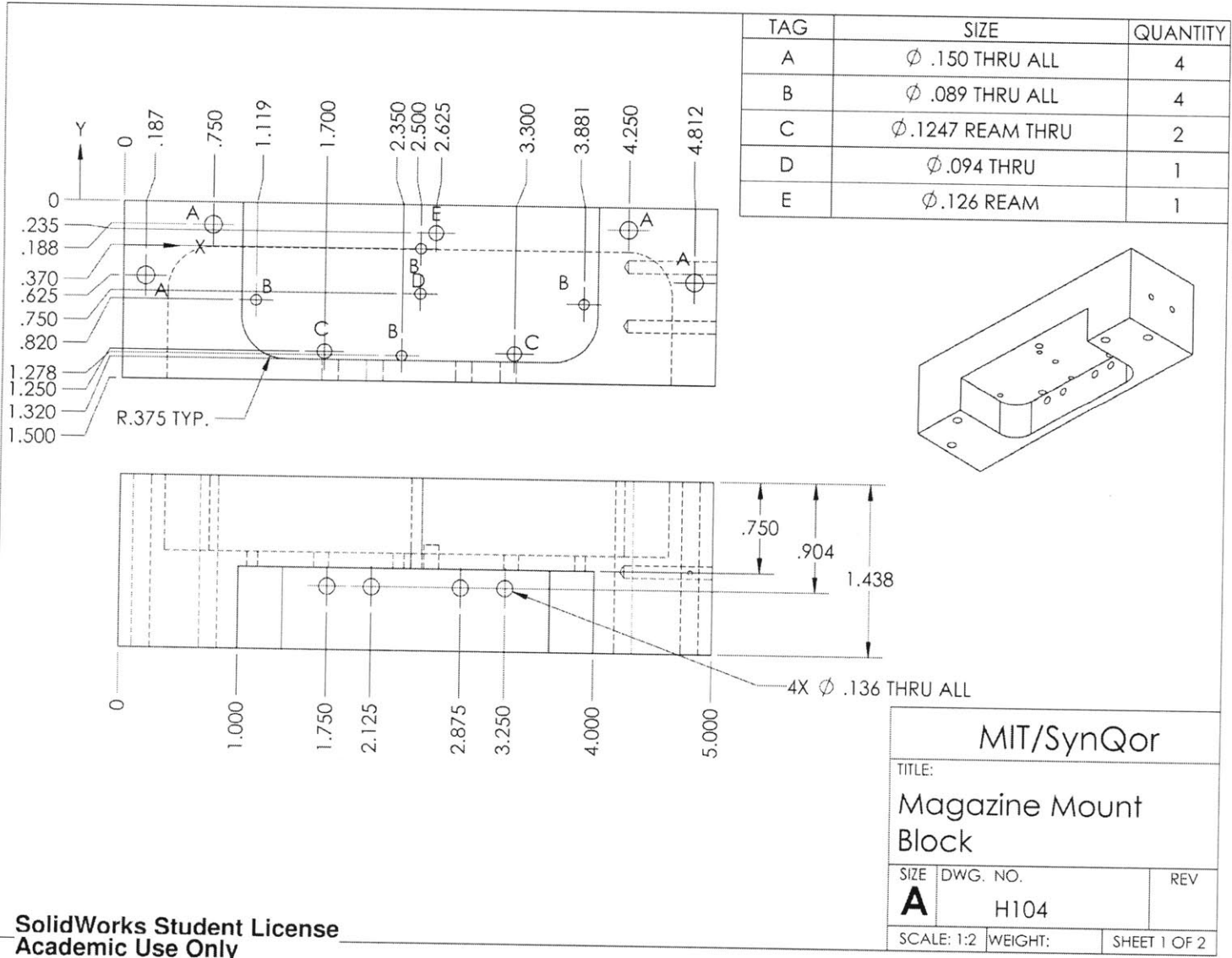

SolidWorks Student License
Academic Use Only

MIT/SynQor		
TITLE: Magazine Mount Block		
SIZE A	DWG. NO. H104	REV
SCALE: 1:2	WEIGHT:	SHEET 1 OF 2

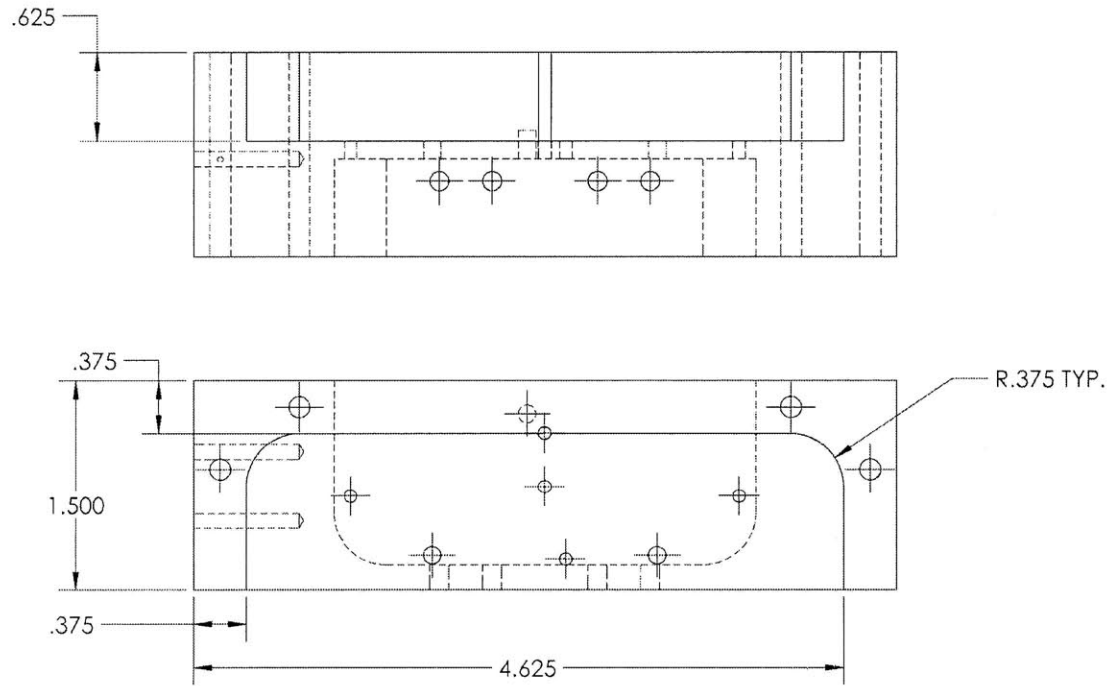

MIT/SynQor		
TITLE: Magazine Mount Block		
SIZE A	DWG. NO. H104	REV
SCALE: 1:2	WEIGHT:	SHEET 2 OF 2

SolidWorks Student License
Academic Use Only

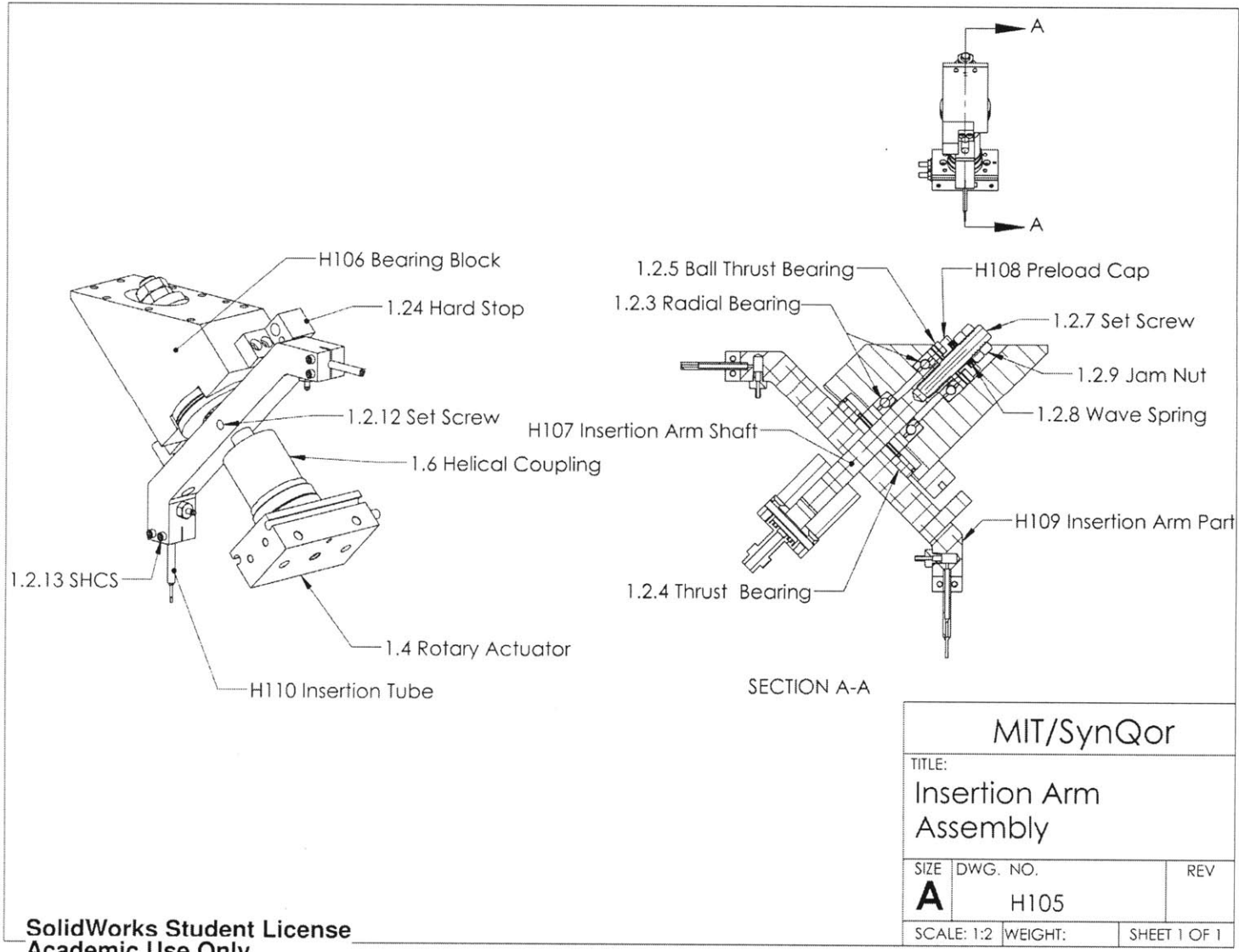

SolidWorks Student License
Academic Use Only

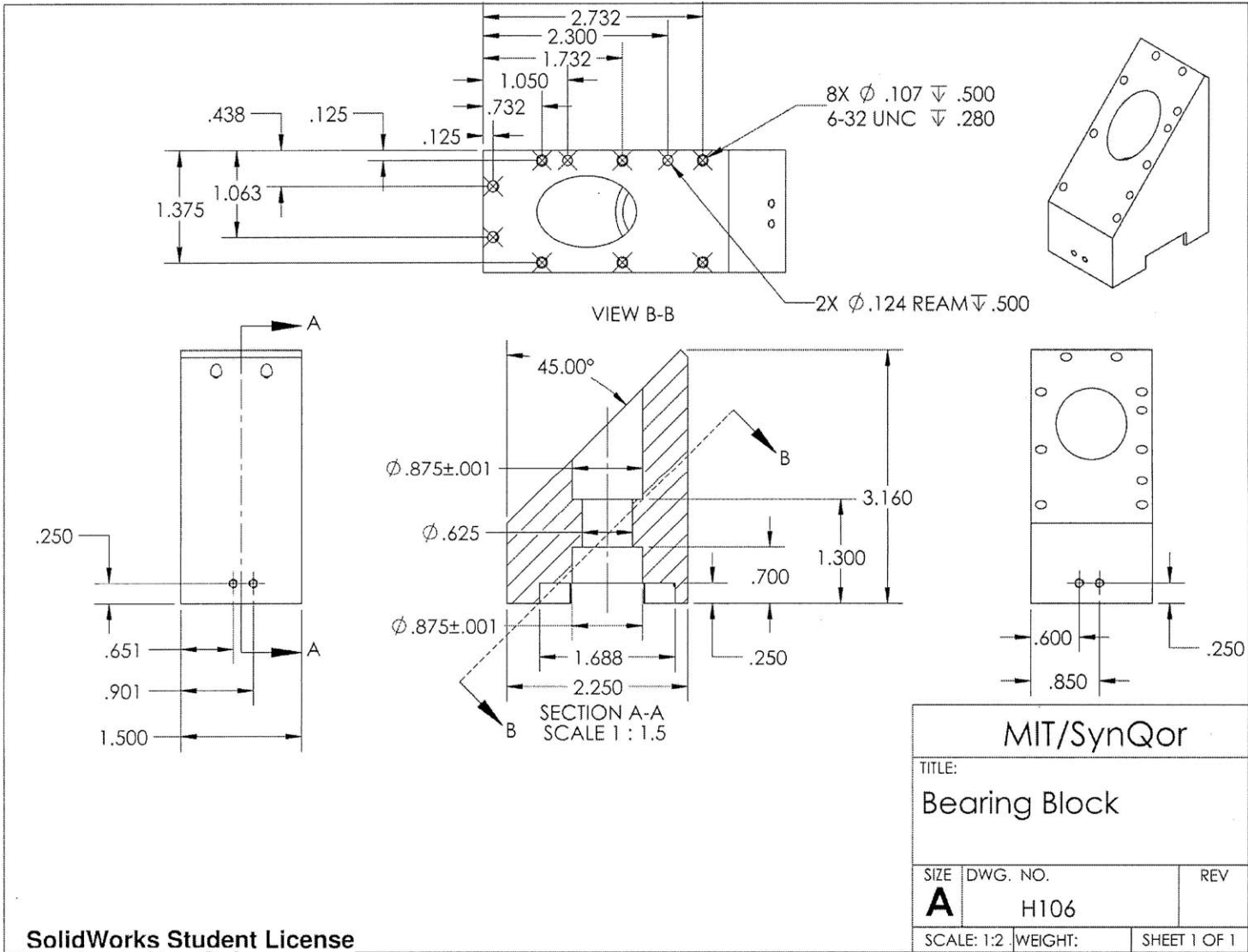

SolidWorks Student License
Academic Use Only

5/16-18 Tapped Hole
▽0.625

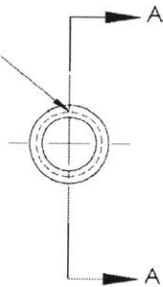

Ø.375

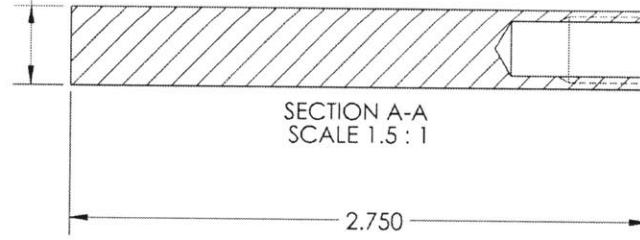

SECTION A-A
SCALE 1.5 : 1

Notes:

- 1) Make from 3/8" x 3"LG SS Dowel pin
- 2) Face both ends

MIT/SynQor

TITLE:

Insertion Arm
Shaft

SIZE DWG. NO.

A

H107

REV

SCALE: 1:1 WEIGHT:

SHEET 1 OF 1

SolidWorks Student License
Academic Use Only

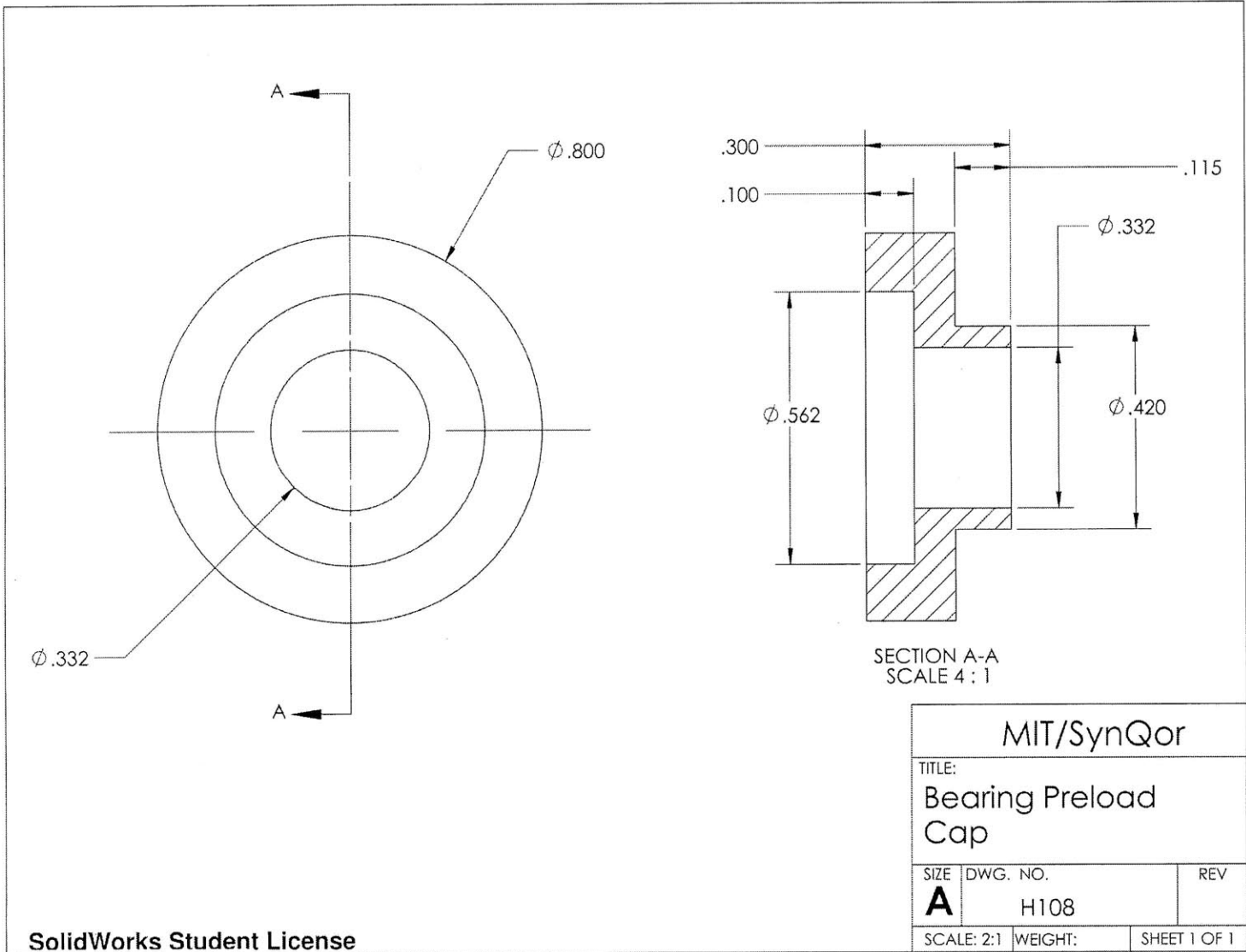

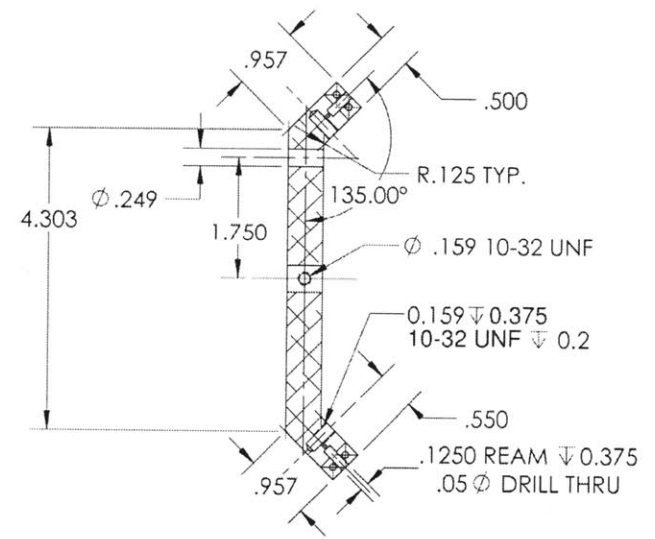
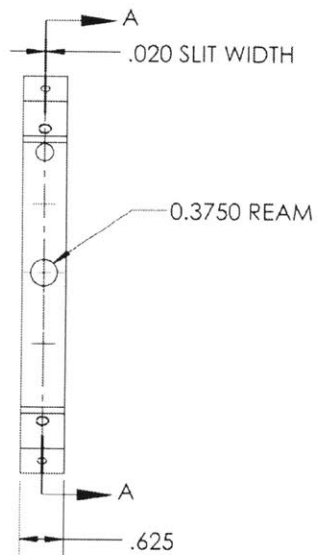

SECTION A-A

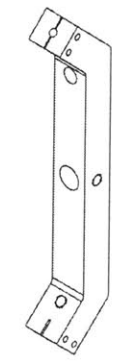

MIT/SynQor		
TITLE: Insertion Arm		
SIZE	DWG. NO.	REV
A	H109	
SCALE: 1:2	WEIGHT:	SHEET 1 OF 1

SolidWorks Student License
Academic Use Only

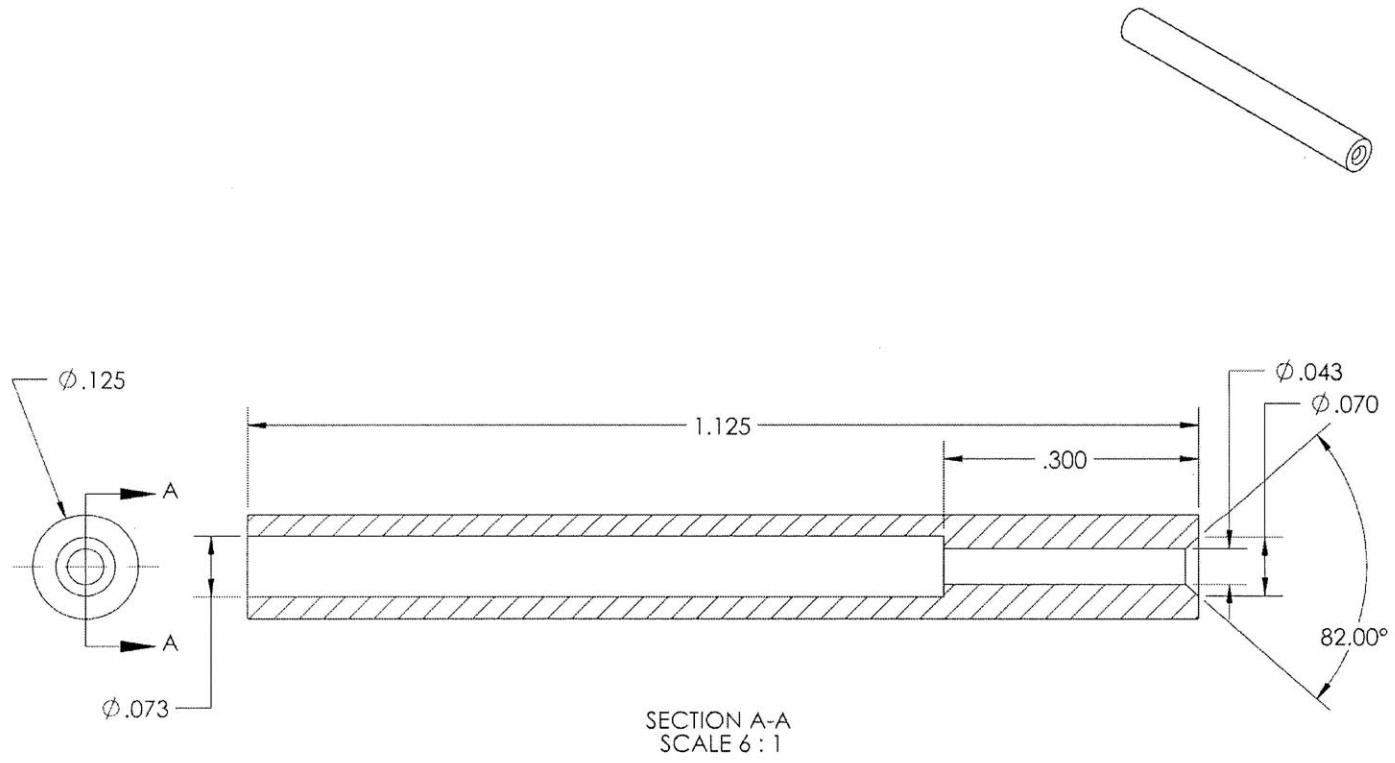

SECTION A-A
SCALE 6 : 1

MIT/SynQor		
TITLE: Insertion Tube		
SIZE	DWG. NO.	REV
A	H110	
SCALE: 2:1	WEIGHT:	SHEET 1 OF 1

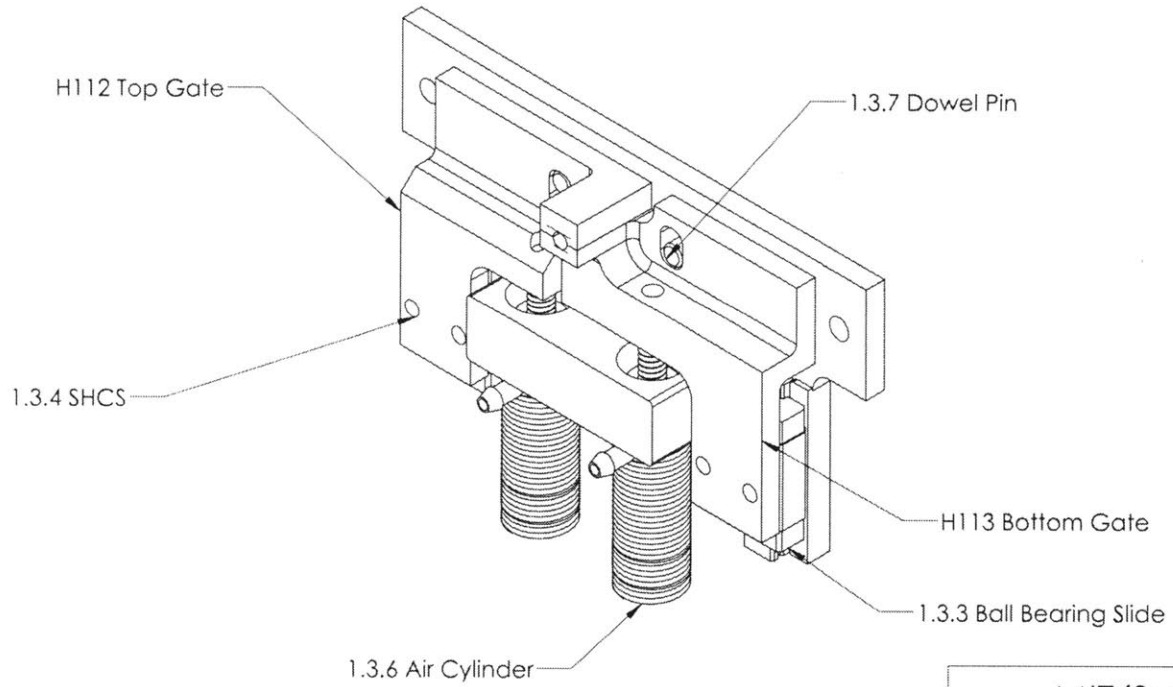

MIT/SynQor		
TITLE: Pin Escapement Assembly		
SIZE	DWG. NO.	REV
A	H111	
SCALE: 1:1	WEIGHT:	SHEET 2 OF 2

SolidWorks Student License
Academic Use Only

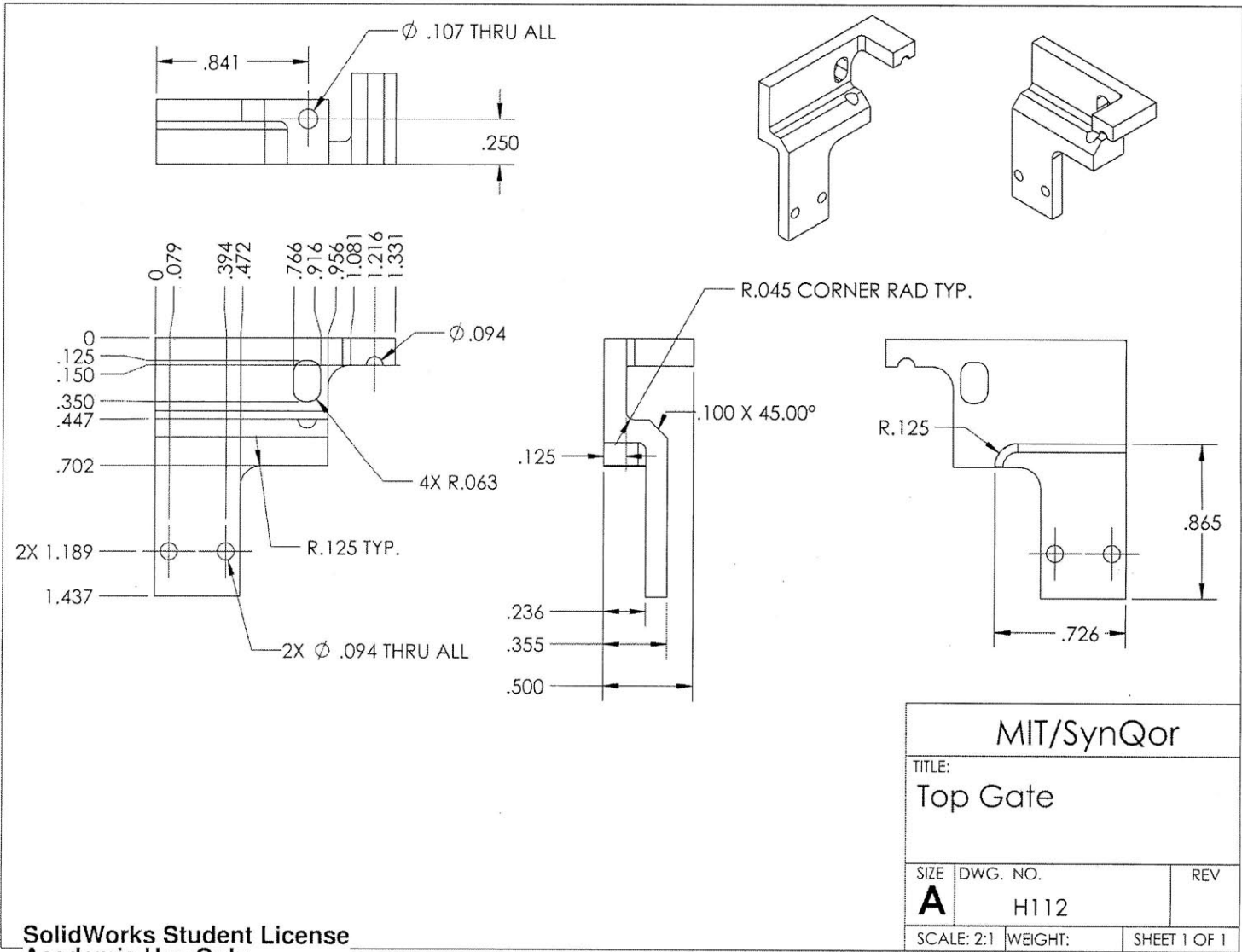

SolidWorks Student License
Academic Use Only

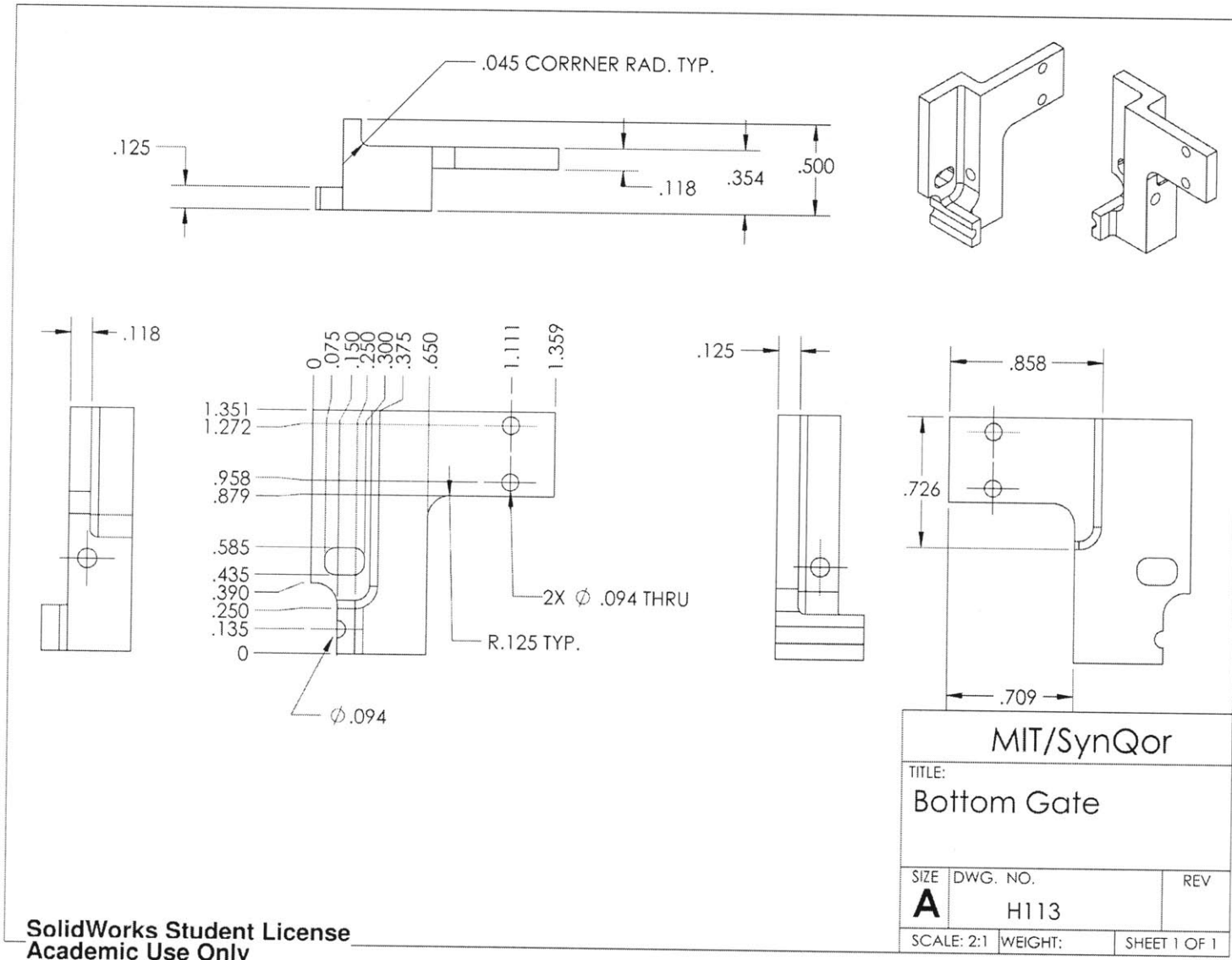

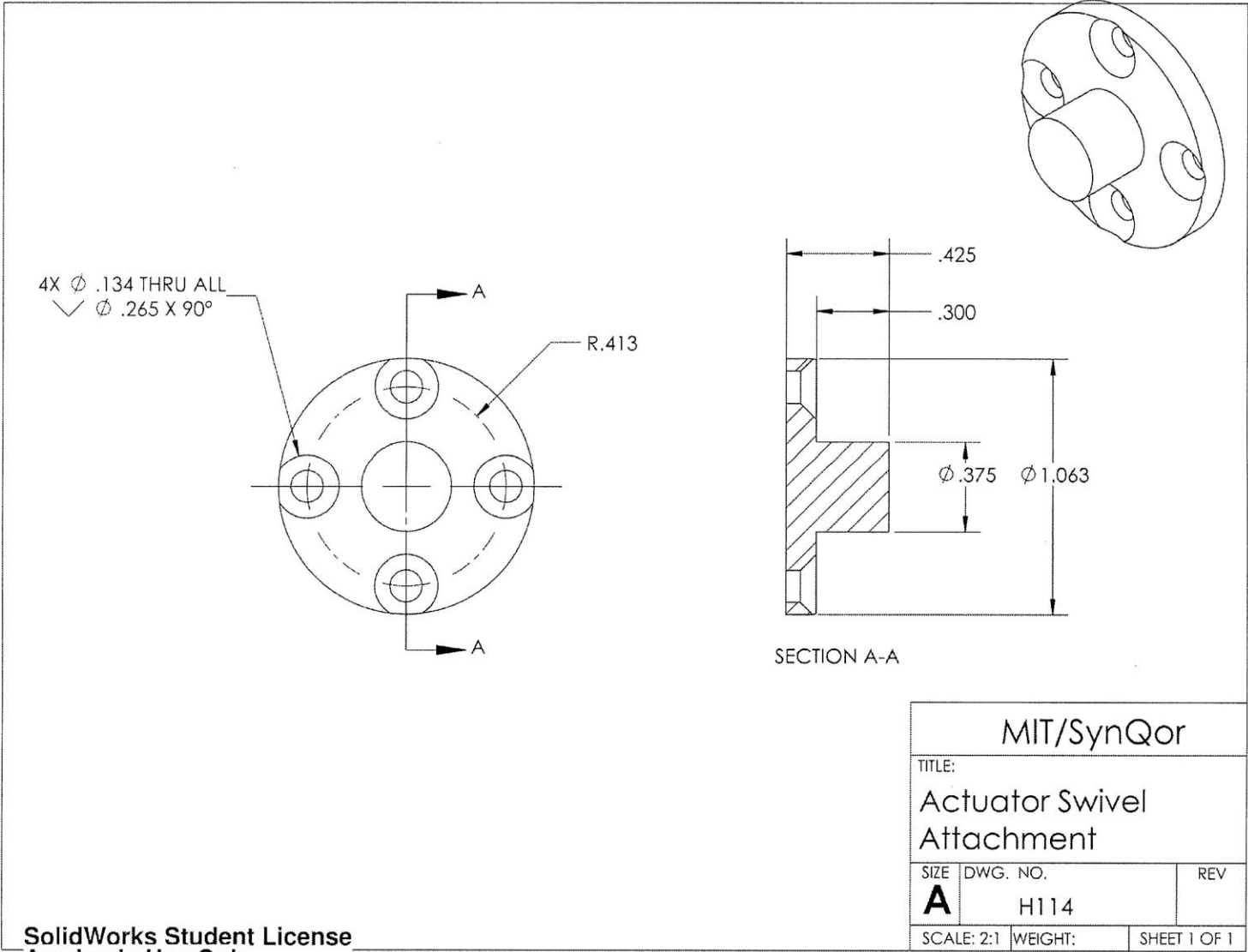

SolidWorks Student License
Academic Use Only

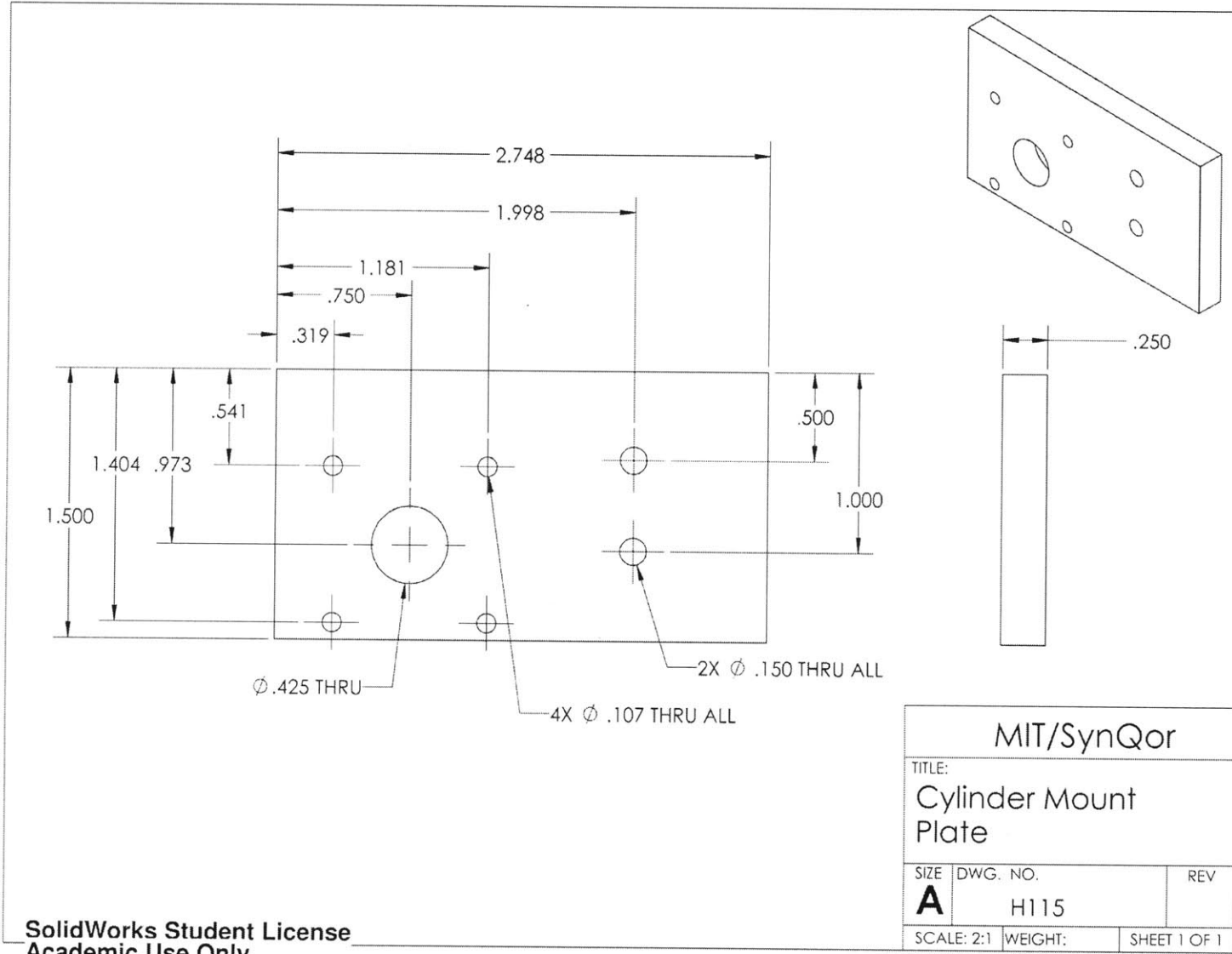

SolidWorks Student License
Academic Use Only

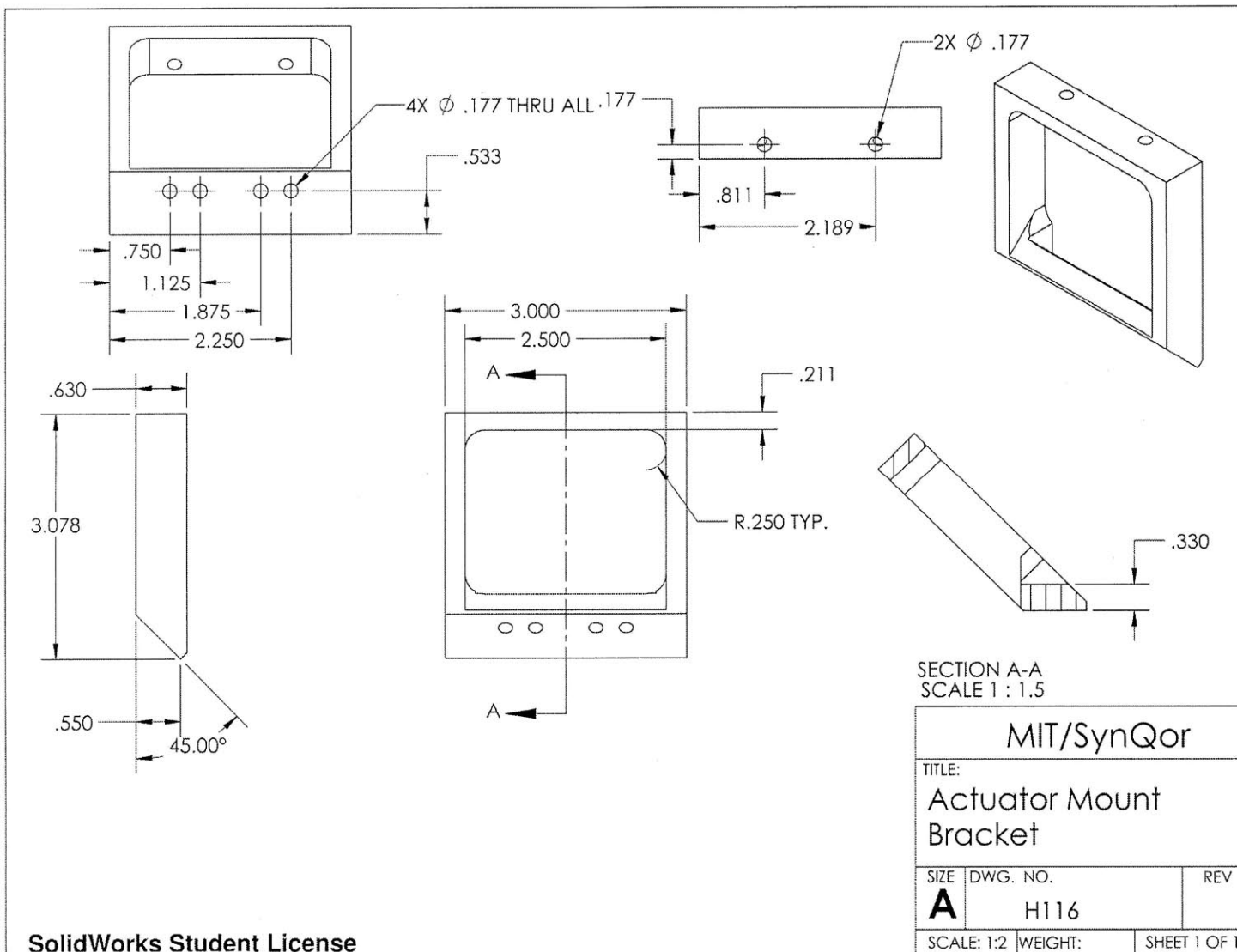

SolidWorks Student License
Academic Use Only

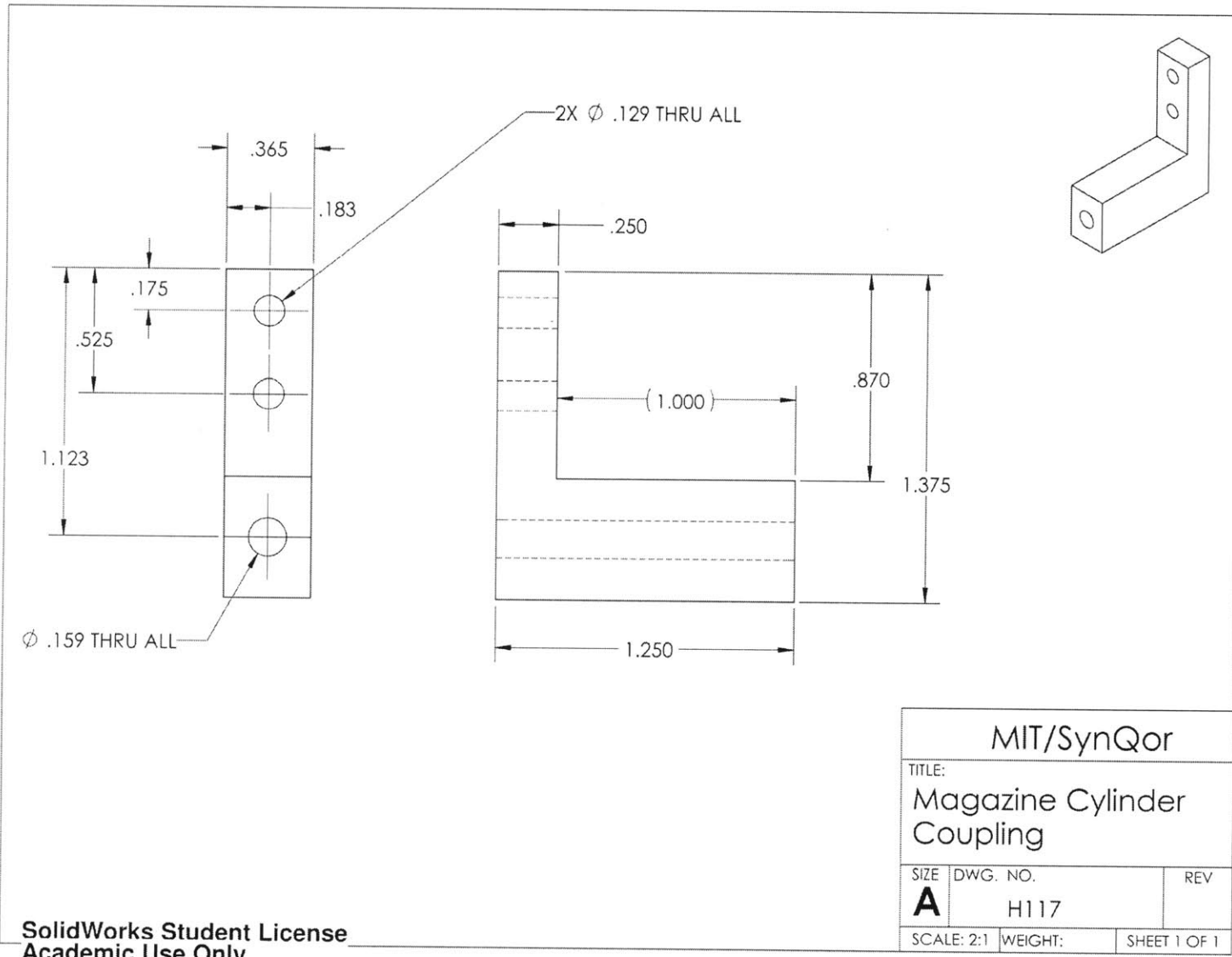

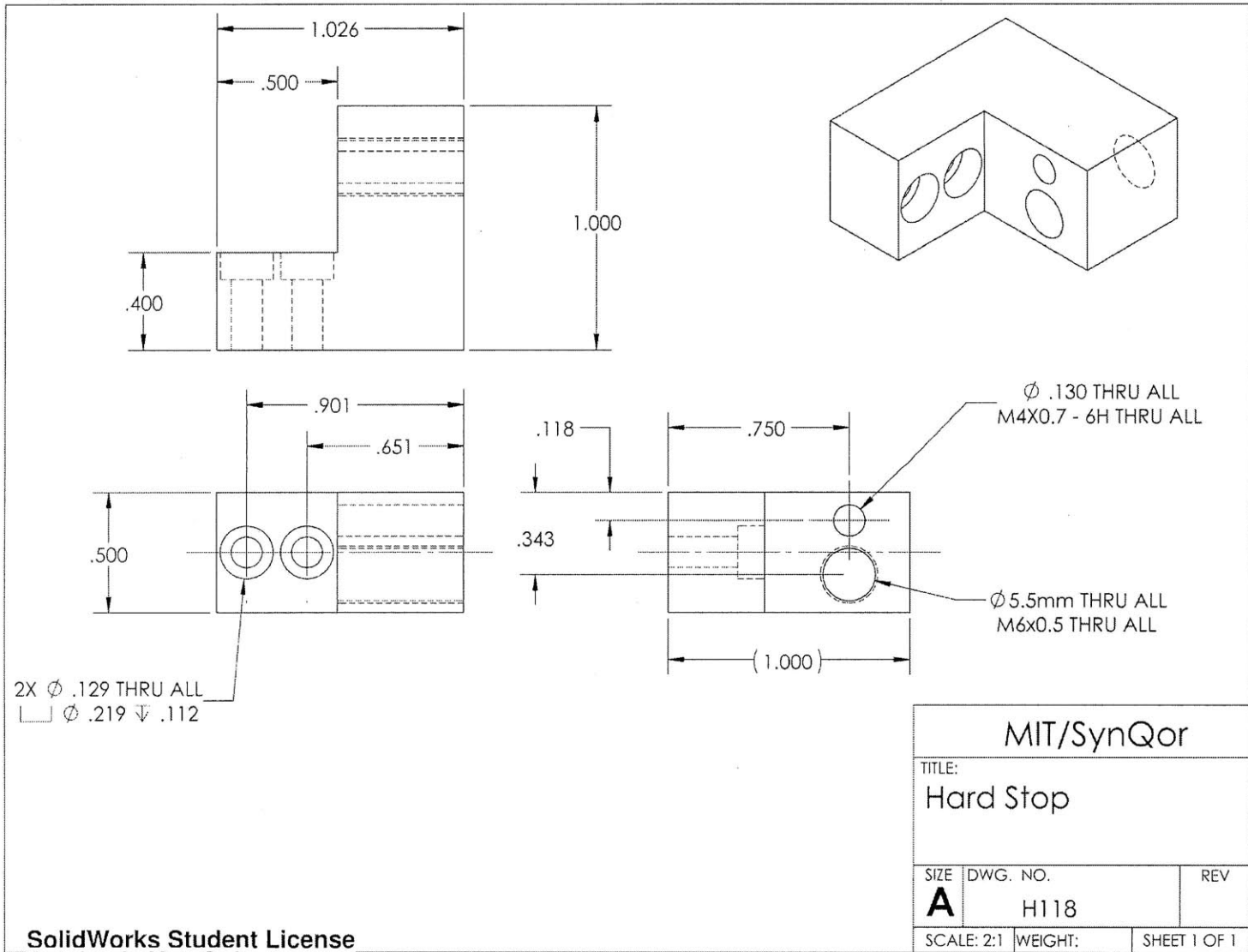

SolidWorks Student License
Academic Use Only

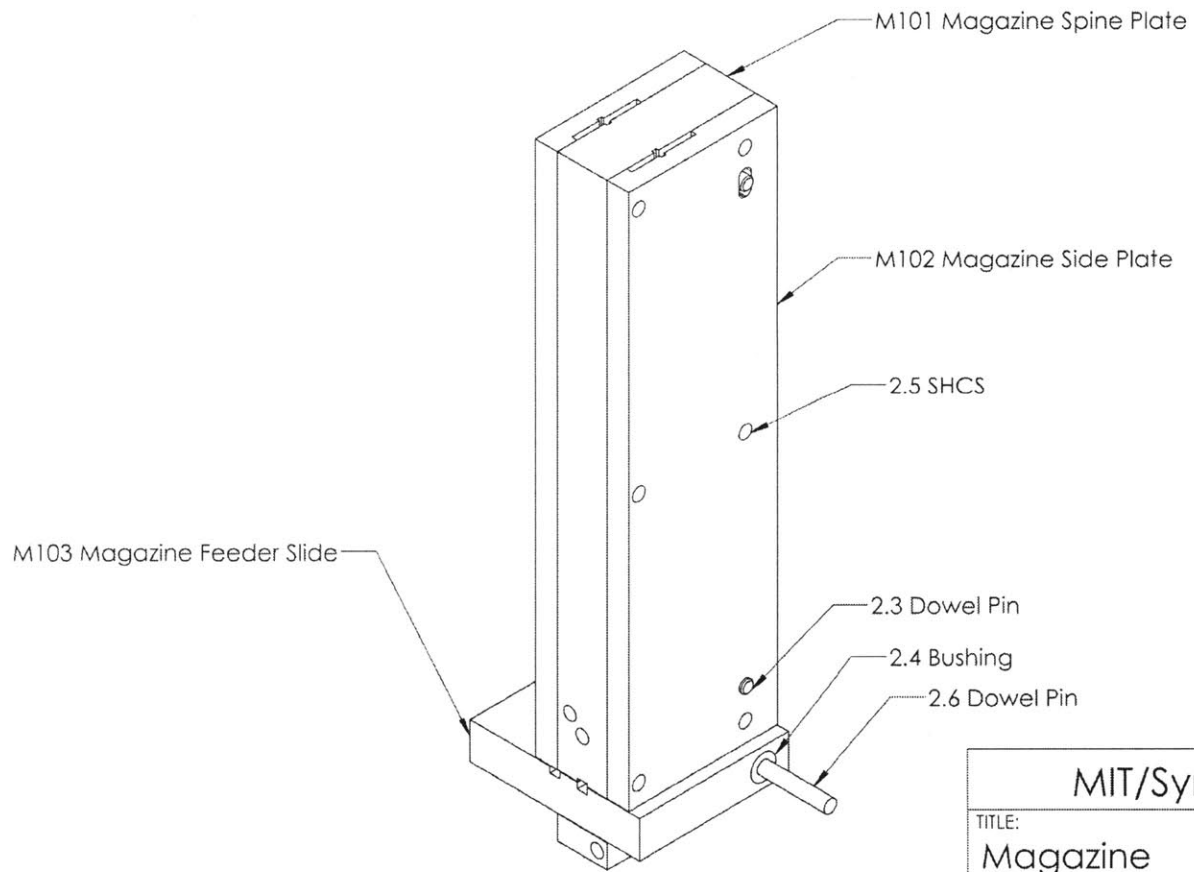

MIT/SynQor		
TITLE: Magazine Assembly		
SIZE	DWG. NO.	REV
A	M100	
SCALE: 1:2	WEIGHT:	SHEET 1 OF 1

SolidWorks Student License
Academic Use Only

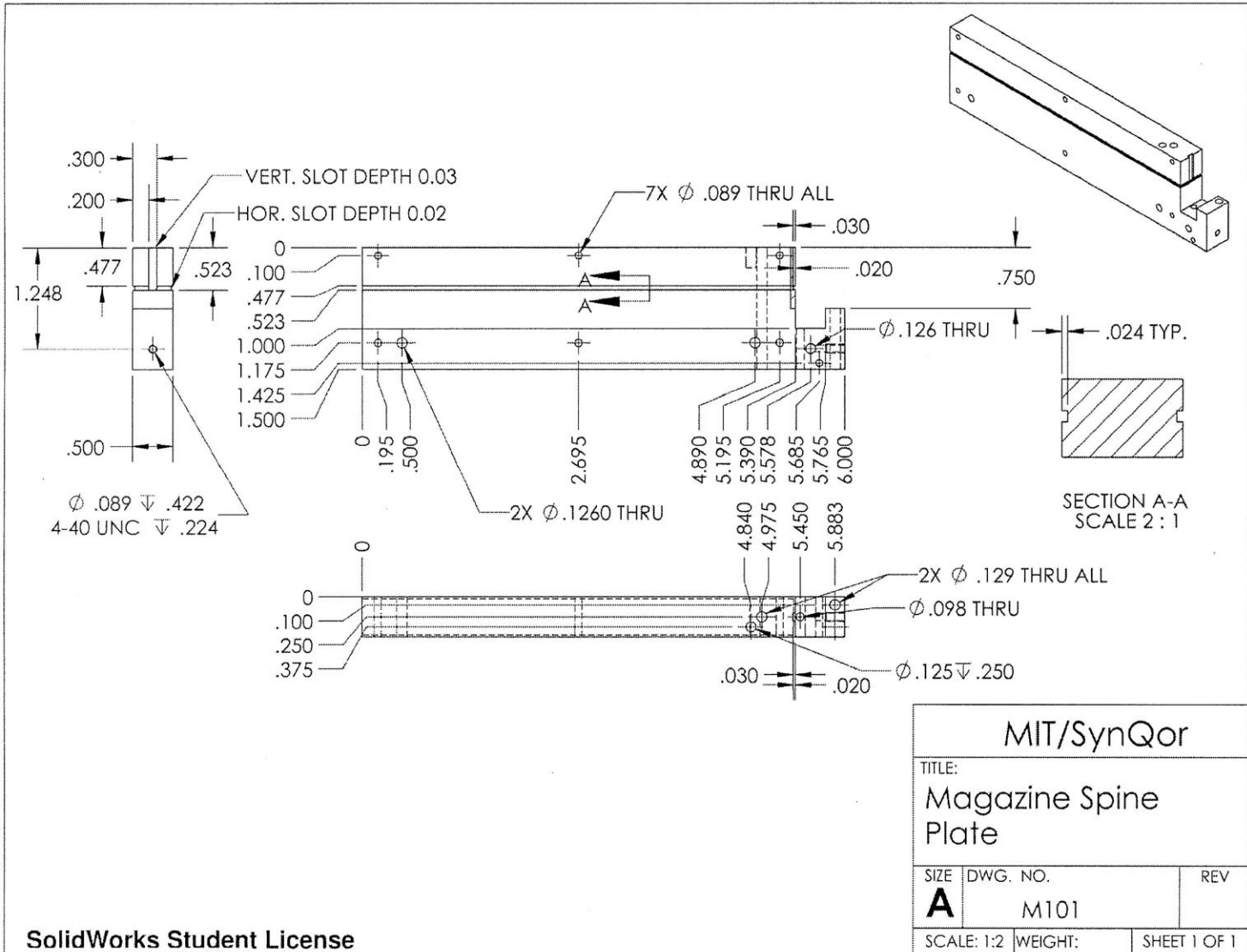

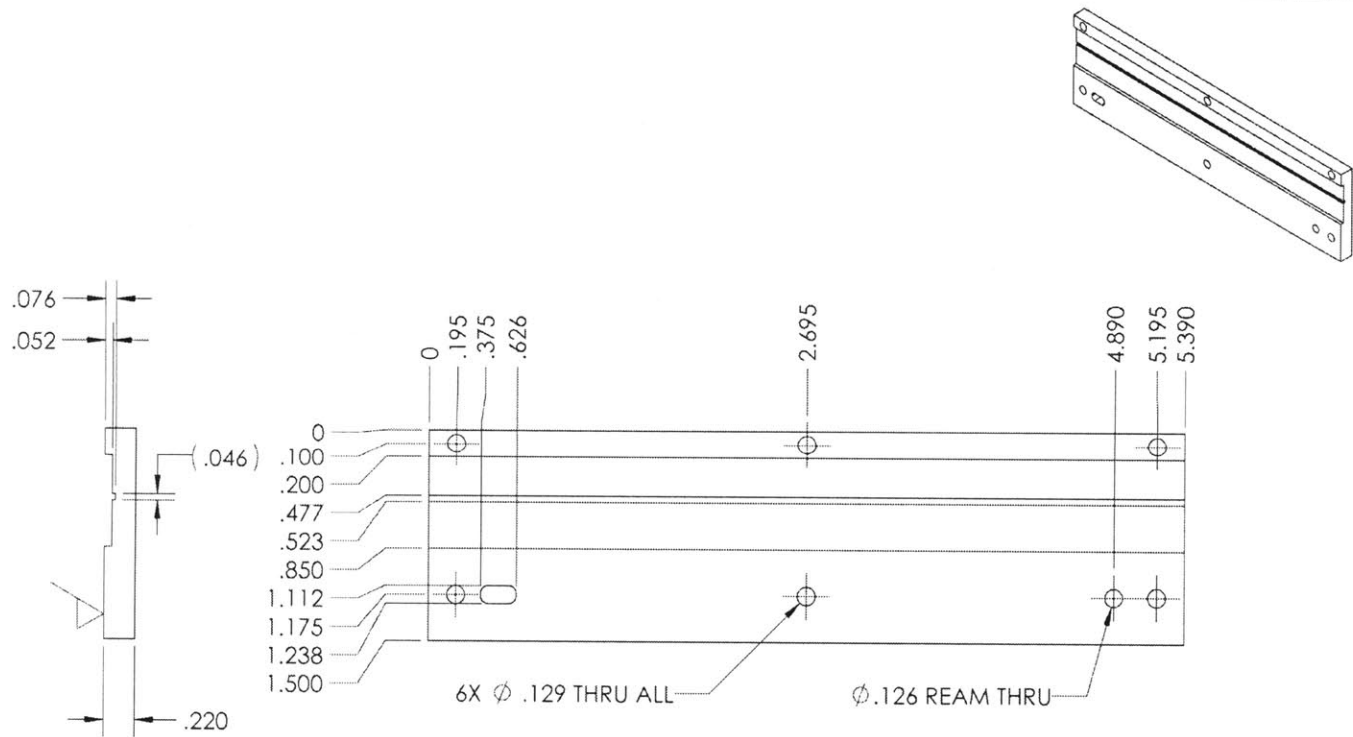

QTY: 2

MIT/SynQor		
TITLE: Magazine Side Plate		
SIZE A	DWG. NO. M102	REV
SCALE: 1:2	WEIGHT:	SHEET 1 OF 1

SolidWorks Student License
Academic Use Only

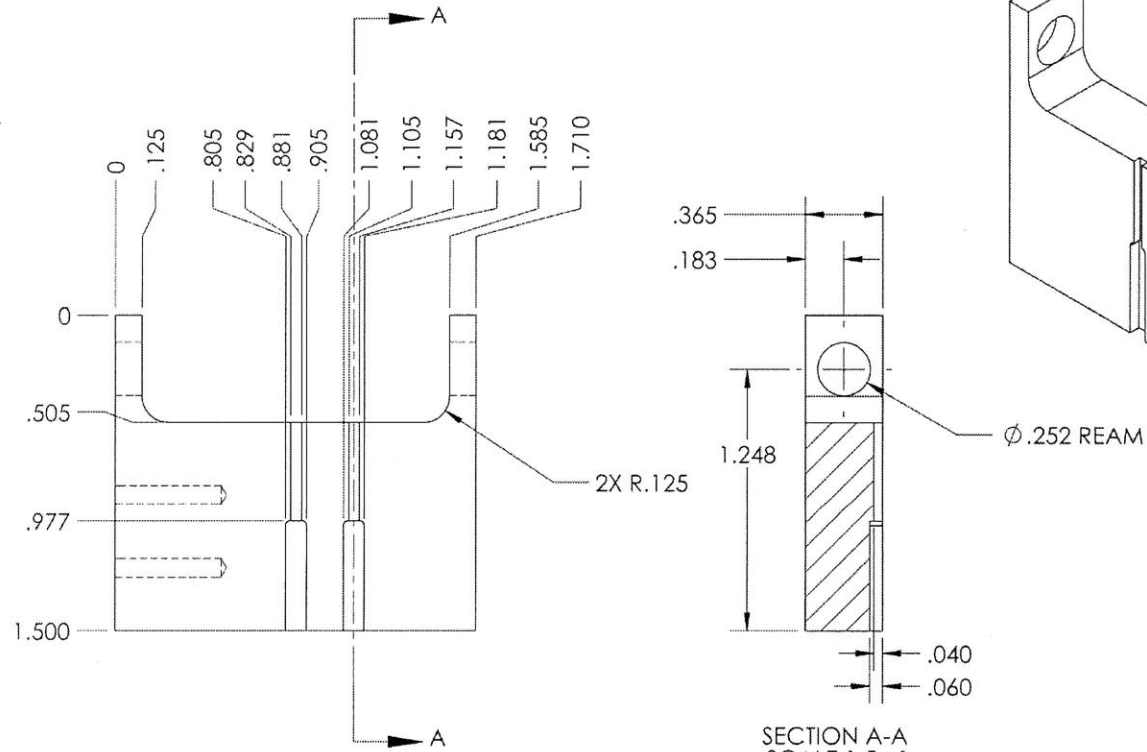

SolidWorks Student License
Academic Use Only

MIT/SynQor		
TITLE: Magazine Feeder Slide		
SIZE	DWG. NO.	REV
A	M103	
SCALE: 1:1	WEIGHT:	SHEET 1 OF 1