

A Design Project for an Urban Frontier

by

ROBERT LOUIS HAHN

B.A. Humanities

University of Southern California

1984

Submitted to the
Department of Architecture
in partial fulfillment of the
requirements for the degree of

MASTER OF ARCHITECTURE

at the
Massachusetts
Institute of Technology
June 1992

©Robert Hahn 1992
All rights reserved.

The author hereby grants to MIT
permission to reproduce and
distribute publicly copies of this
thesis document in whole or
in part.

Signature of Author

Robert Hahn, Department of Architecture
May 8th, 1992

Certified by

Bill Hubbard, Jr., Associate Professor
Thesis Supervisor

Accepted by

Rotch
MASSACHUSETTS INSTITUTE
OF TECHNOLOGY

John R. Myer, Professor of Architecture
Chairman, Departmental Committee on Graduate Students

JUN 05 1992

LIBRARIES

A Design Project for an Urban Frontier

by

Robert Louis Hahn
Submitted to the Department of
Architecture on May 8th, 1992
in partial fulfillment of the
requirements for the Degree of
Master of Architecture

Abstract

The interplay between the form and infrastructure of modern cities produces spatial and temporal dimensions which allow for erratic growth and fragmentary perception. Though their origins can be clearly seen in urban development since the Renaissance, density, movement, and pace in contemporary cities increase as meaningful boundaries are erased by rising consumption of services and a spate of traffic (automobile, communication, utility). While property values limit accessibility to inner urban space, the city expands outwardly, generally following the path of least resistance. In so doing, the increased demands on infrastructure cleave existing urban textures, creating

anomalies in the landscape.

As a result, large open spaces for public use are either dislocated (to suburbia), restricted (institutionalized where most public), or simply "left over" as remnants of previous programs (abandoned buildings) or the fall-out of large scale construction (highways, public transport, utilities, etc.).

The potential of these latter spaces for public use is often unrecognized. This thesis will argue that due to their very nature, cities produce such spaces by default and that they can be employed for public use as a frontier in the urban psyche. The design for such a frontier would support a variety of programs based on public events. As soon as one event takes place, another would follow according to the rhythm of the city. In this

way, it could act as a stabilizer by activating places which are really just dormant and providing a permanent fixture for civic activity.

Thesis Supervisor: Bill Hubbard
Title: Associate Professor

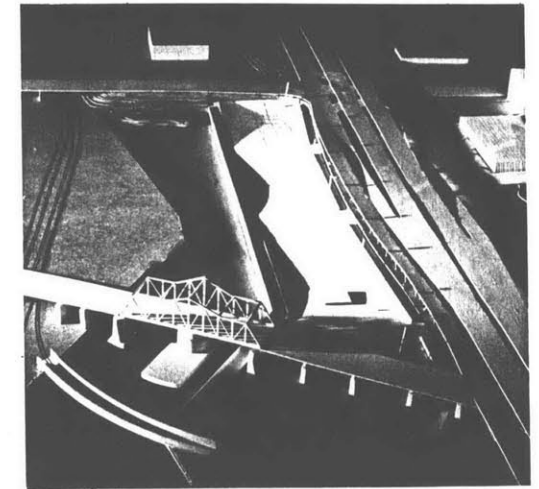

CONTENTS

Preface	7
Site	13
Thesis	19
Design	31
Program	43
Sources	51

PREFACE

It is inconceivable to imagine the planning of cities without surveying. Providing fixed points for future reference and marking new boundaries, it documents and enables us to shape the landscape from the scale of a lightpole to that of the metropolis. In placing his transit, the surveyor takes a bearing on the transience of the physical world, he fixes a reference point by which one can measure transformation in both the natural and built environments.

By ordering these points, one can construct the totality of the city or the smallest block. No matter what the scale, an overview is presented such that one can take stock of the whole as when looking at a map or an aerial photograph. The relationship of each part to

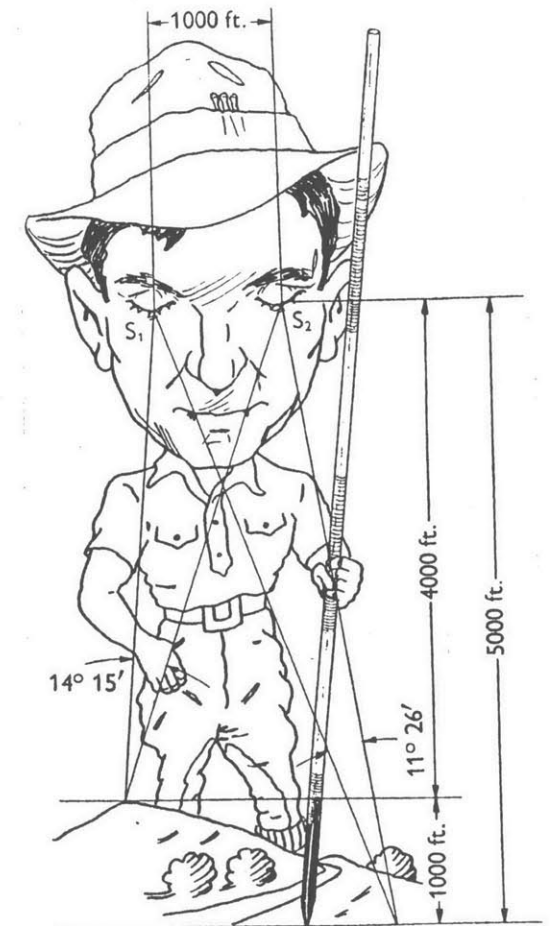
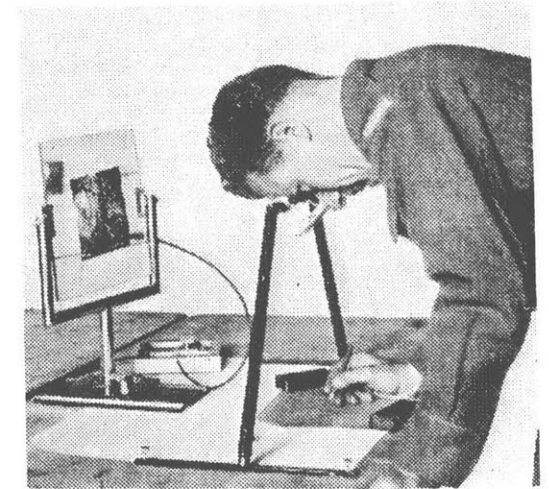

Aerial view of downtown Boston.

Surveying techniques.

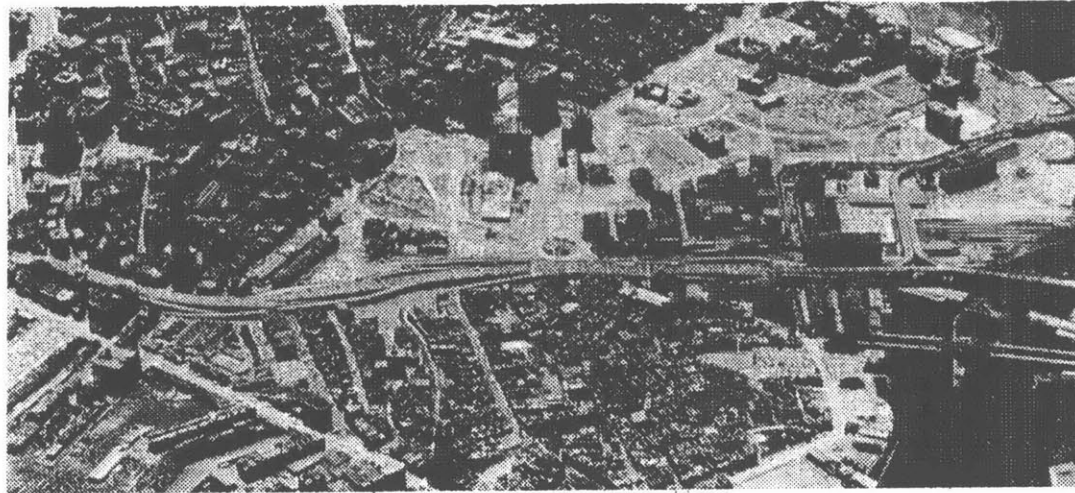

another is spatially clear like so many points on a grid. The experience of those parts, however, remains detached.

Modern cities can be characterized by the pace and scale at which they are transformed through building. Over a period of a few years, entire districts can be completely re-built and the separation of distant areas reduced to minutes. Essential to the planning of urban infrastructure and renewal projects is the ability to view a given area as a discrete part. On this level, districts are legible as entities connected or cut-off by roads, highways, railway lines or waterways. But as the spatial and temporal dimensions of the city are altered on such a large scale, the perception of it becomes more disjointed: the view the

Boston's West End in the sixties and in the eighties.



skyline compared to being at the foot of a skyscraper, or the difference between following a map and driving on the highway.

This disparity of perceiving the "city" and actually inhabiting it is a fundamental urban experience of today. The subject of this thesis is to develop a design project for a site which elicits this quality.

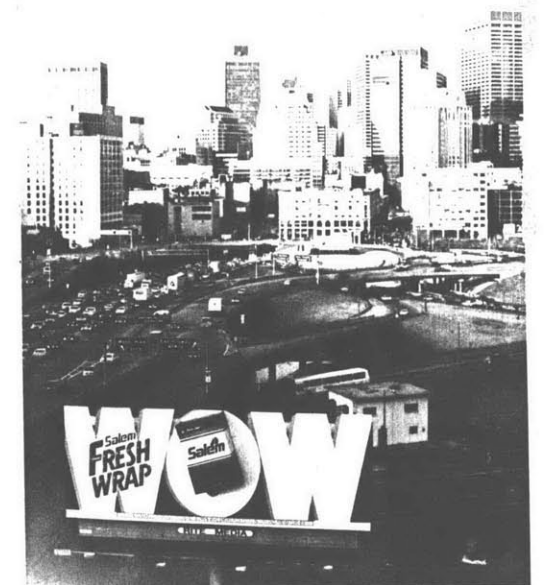





SITE

Bounded by elevated roadways on three sides and Fort Point Channel on the other, the site is highly visible though difficult to access. West Fourth Street to the south is elevated on earth and then by bridge; on the north side lies Broadway which is supported thirty feet above ground level by massive masonry piers; and Highway 93 (Central Artery) with its on and off ramps and service road, forms a wall to the west. It is quite easy to loop around this area by taking various combinations of these roads. But together with the Channel and the many railway tracks which lie beyond it, they cordon off the site from adjacent areas. Due to their dissimilarity, they attest the true nature of the site itself: it was created by default, simply left over from successive waves of

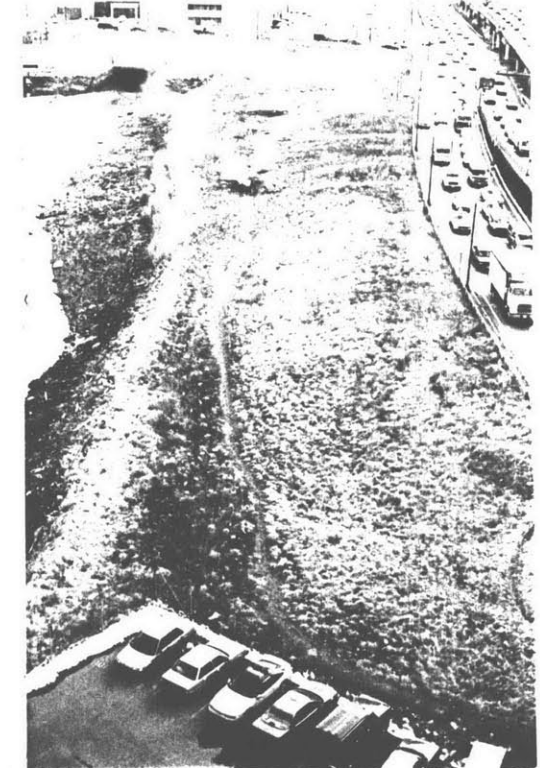
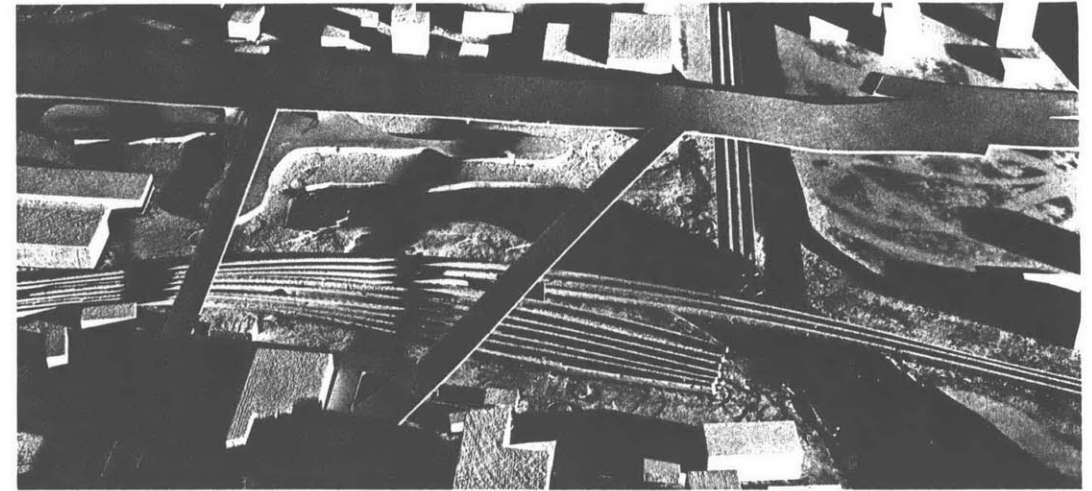

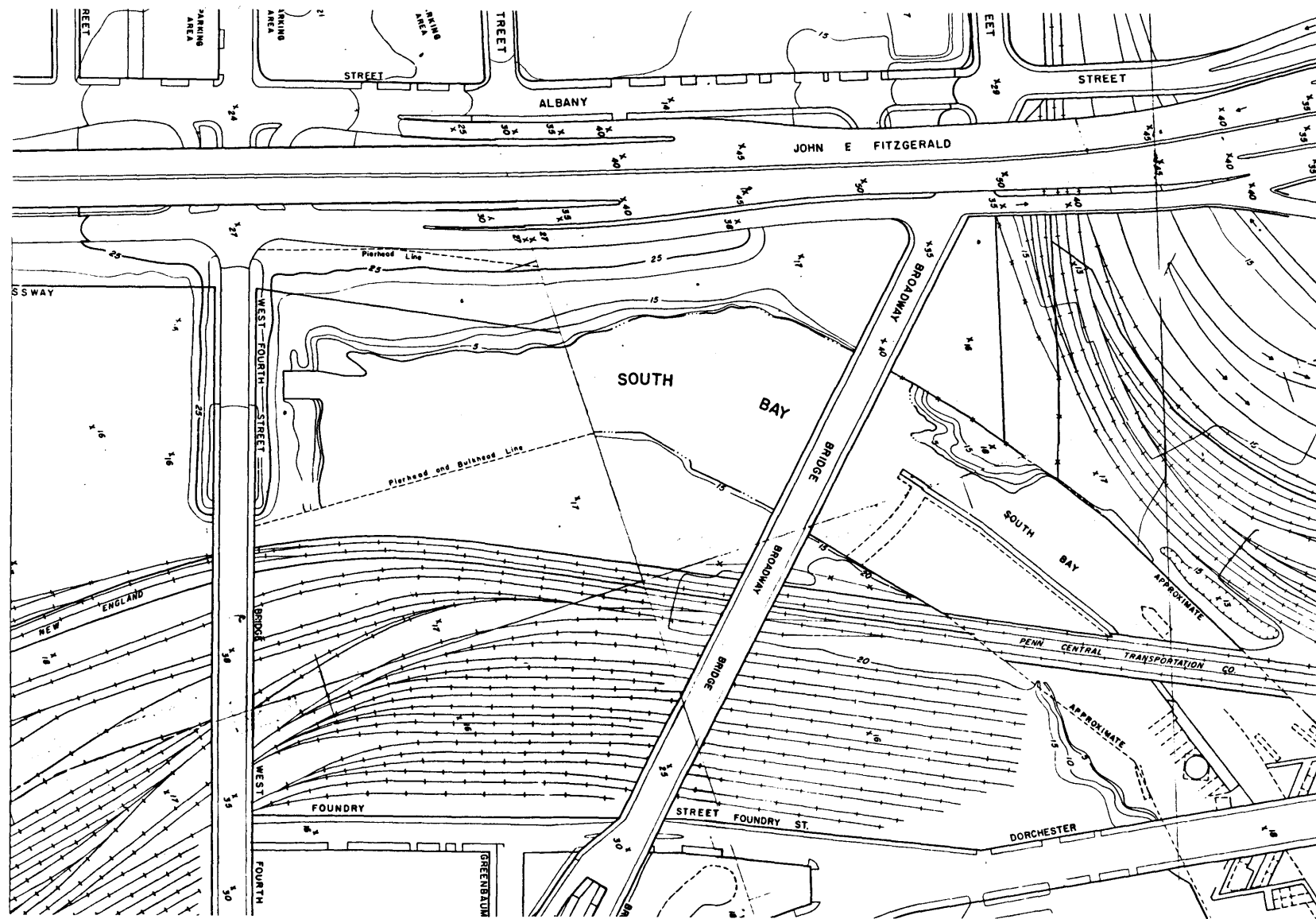

large scale intervention : bridges, highways, landfill, rail and subway tracks.

Despite its proximity to the city, it is cut-off from it by the very infrastructural elements which make it visually accessible. The only way to get to the site is by turning off Albany Street and crossing under 93 where both ramps and the service road are sufficiently elevated.

Once on the site, the city (downtown Boston) takes on a different image; it is no longer the place to which all roads lead, but separated and objectified by them. They frame the city by creating visual discontinuity in the foreground and an artificial horizon above ground level. The elevated roadbed is treated then as an element in the urban landscape just as grade changes



or the skyline of the city. The Central Artery is thus a semi-permeable wall and the Channel is a sharply defined edge.

From both inside and outside large scale shifts are visible. Looking down from above, the terrain of the site appears continuous but contained. One views the site from a dynamic vantage point, the automobile, panning across it along with the rest of the city. But from within, a foreshortening of urban space is effected as the middle ground, blocked by roads draws the city closer to a fixed standpoint on the site.







THESIS

Through to the Middle Ages, the continuity of urban settlement was altered mainly by disaster, both natural and man-made. The medieval city grew according to an established pattern, generally delimited by its protective walls or geographic setting.¹ Surveying was not needed to chart expansion. As an urban entity, it was highly legible; the spatial relationships between the public and private spheres were clear, their boundaries well demarcated, and the hierarchy of power firmly rooted. Certain places played well defined roles according to custom and ritual. The central square or market, for instance, sustained a number of simultaneous public functions from trading to celebration. Perceptual and existential dimensions coincided as integral experiences in urban

Piazza del Campo, Siena.

Monteriggioni, Italy.

Medieval cities in Czechoslovakia.

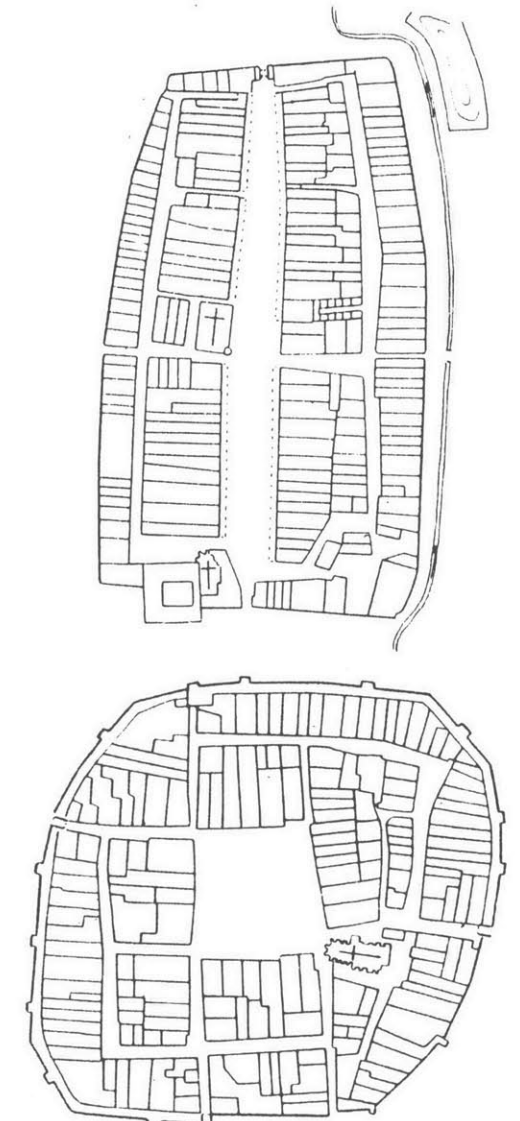
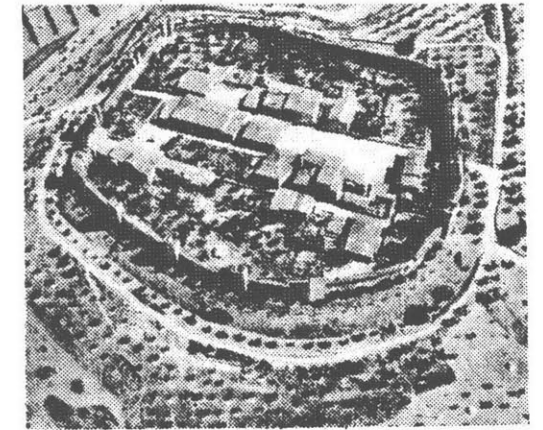
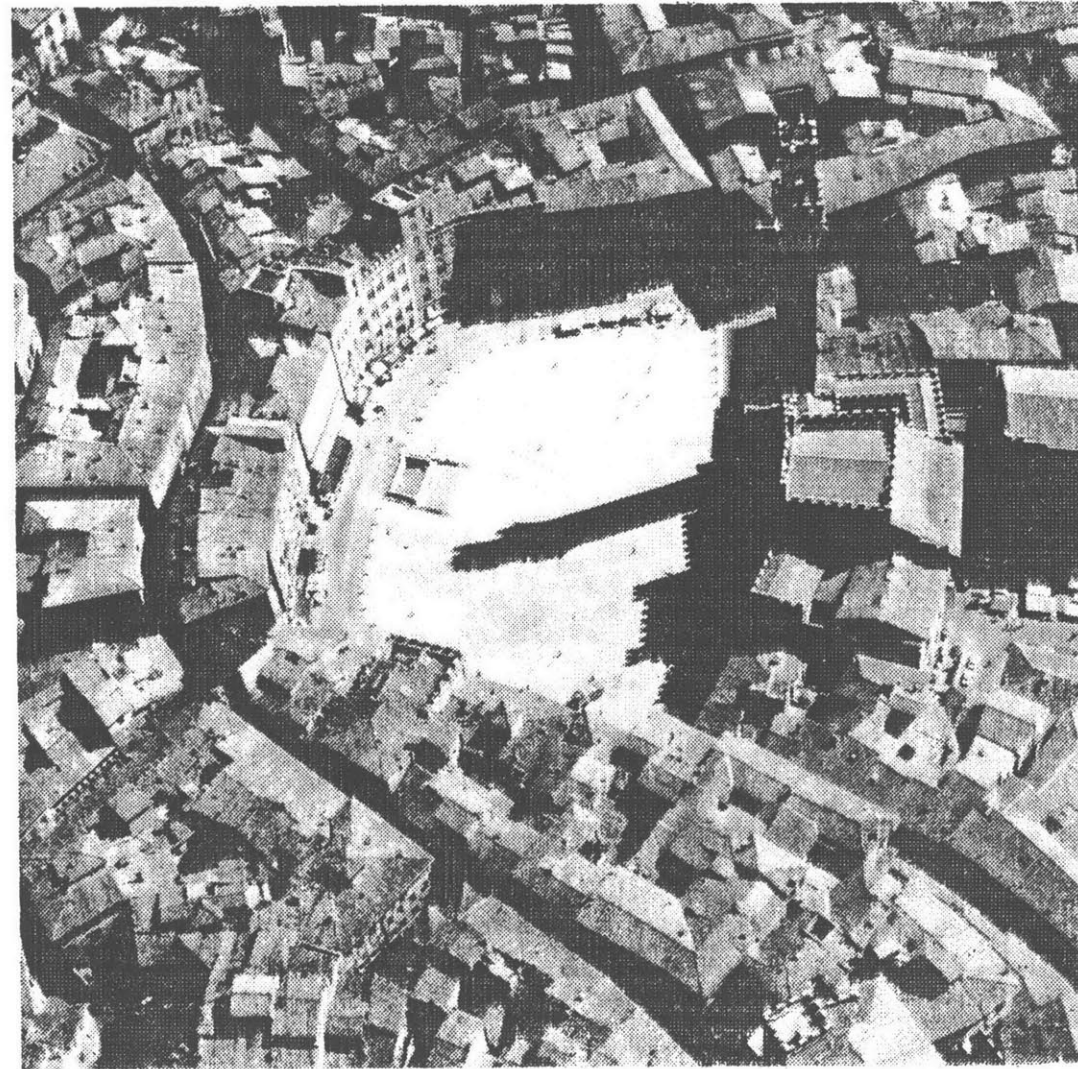

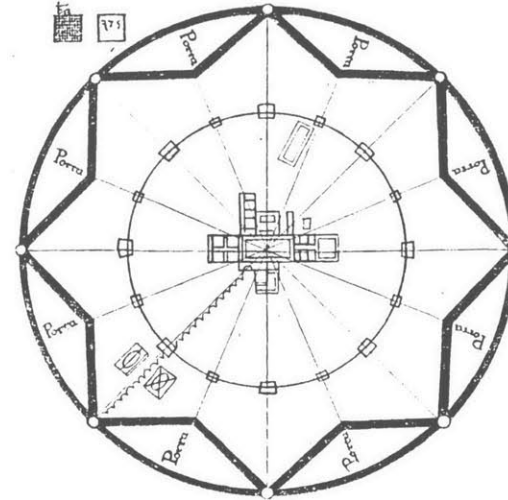
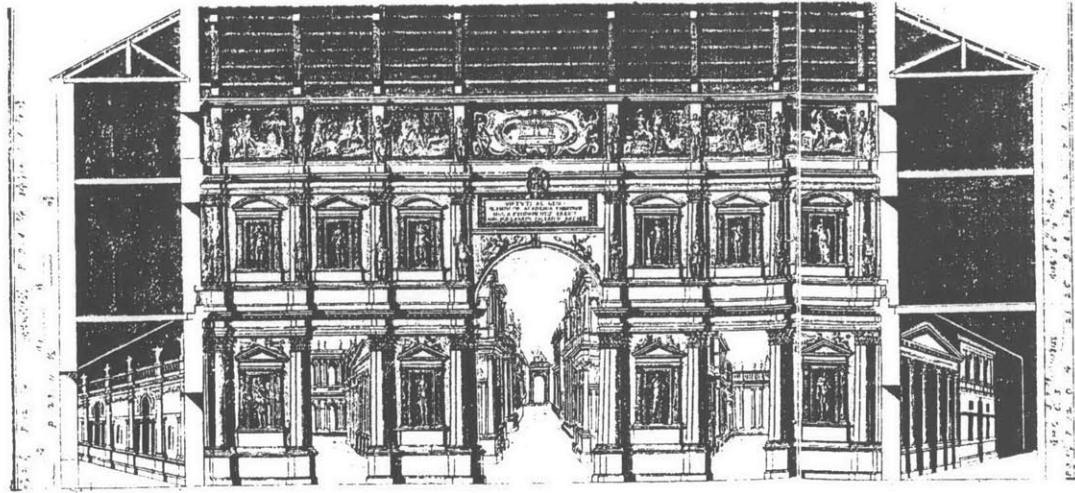

life.

The Renaissance broke with medieval tradition by employing a conceptual basis for design which held "universal validity."² Careful preparation of all aspects of a project before building gave the architect (and planner) more independence and greater control. An ideal city with ideal proportions could be designed and verified through rigorous methods. Further, there was a common code used and read by all that allowed not only for a shared idiom in both design and construction, but also for architectural and urban design to use the same language.³

As new techniques in the natural and social sciences were developed, planning began to take on a greater role in the shaping of the urban environment. Whole

Plan of ideal city of Sforzinda from Filarete.

Nuremberg market place, 19th C.

Woodcut by Scamozzi of Palladio's Teatro Olimpico.

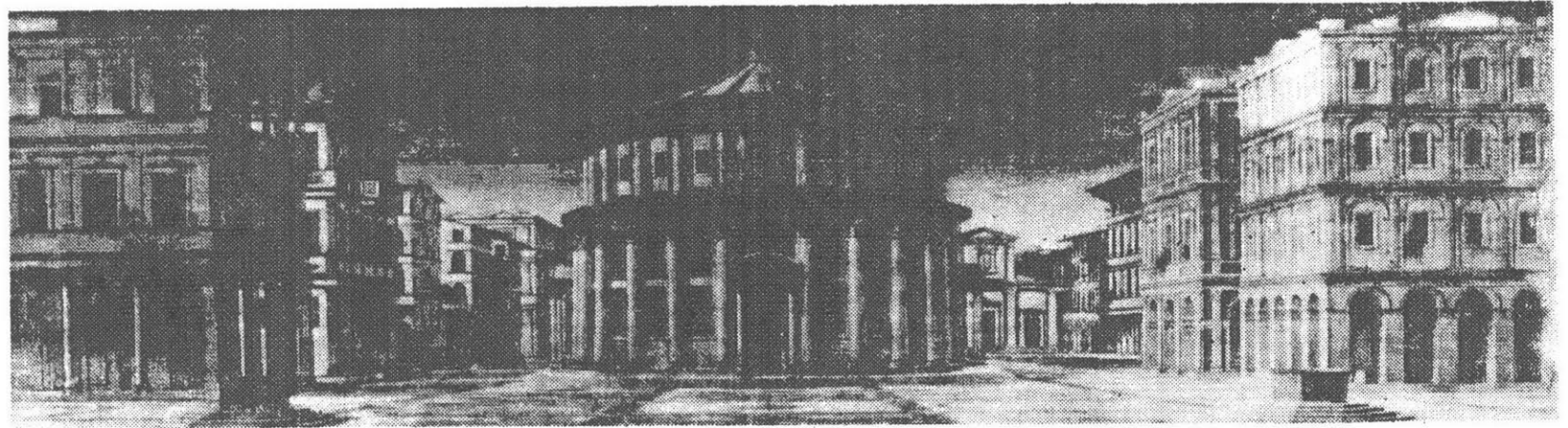

new cities were built and existing ones radically changed to accommodate a growing demand for urban inhabitation. Utopian attempts to create a new order and socially motivated endeavors to cure the ills of the existing one⁴ created an atmosphere which allowed for urban planning to come into its own right, no longer as an ideal, but a social science. A new field was developed to administer the inhabitation of the city through the maintenance and development of its infrastructure, both physical and political.

In the contemporary city, the rate of physical change operates independently of any regular pattern of growth and decay because the scale and tempo at which infrastructure is developed or destroyed has long since

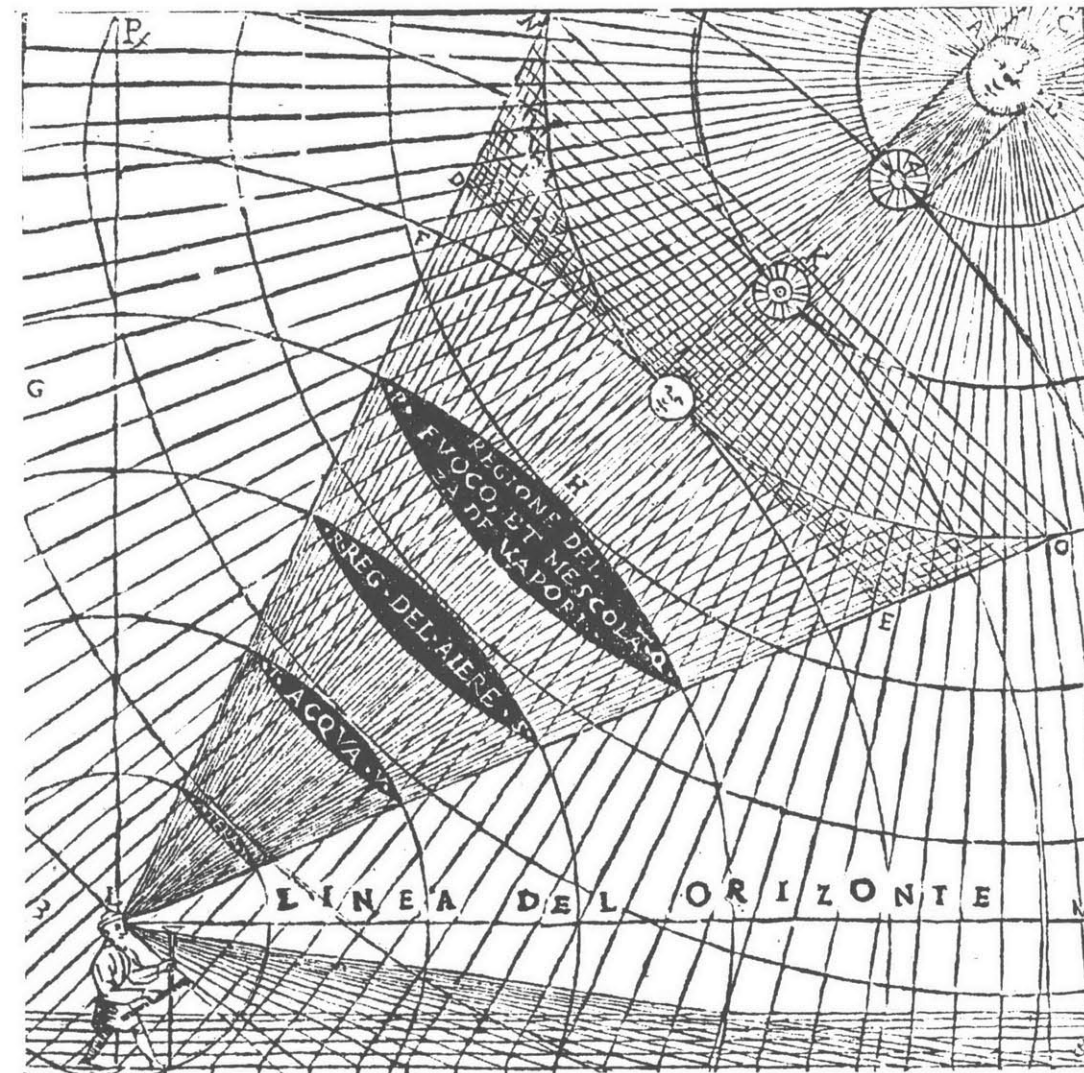

Painting depicting an ideal city, Ducal Palace, Urbino.

Perspectival view penetrating the universe, drawing by Giambattista Caporali.

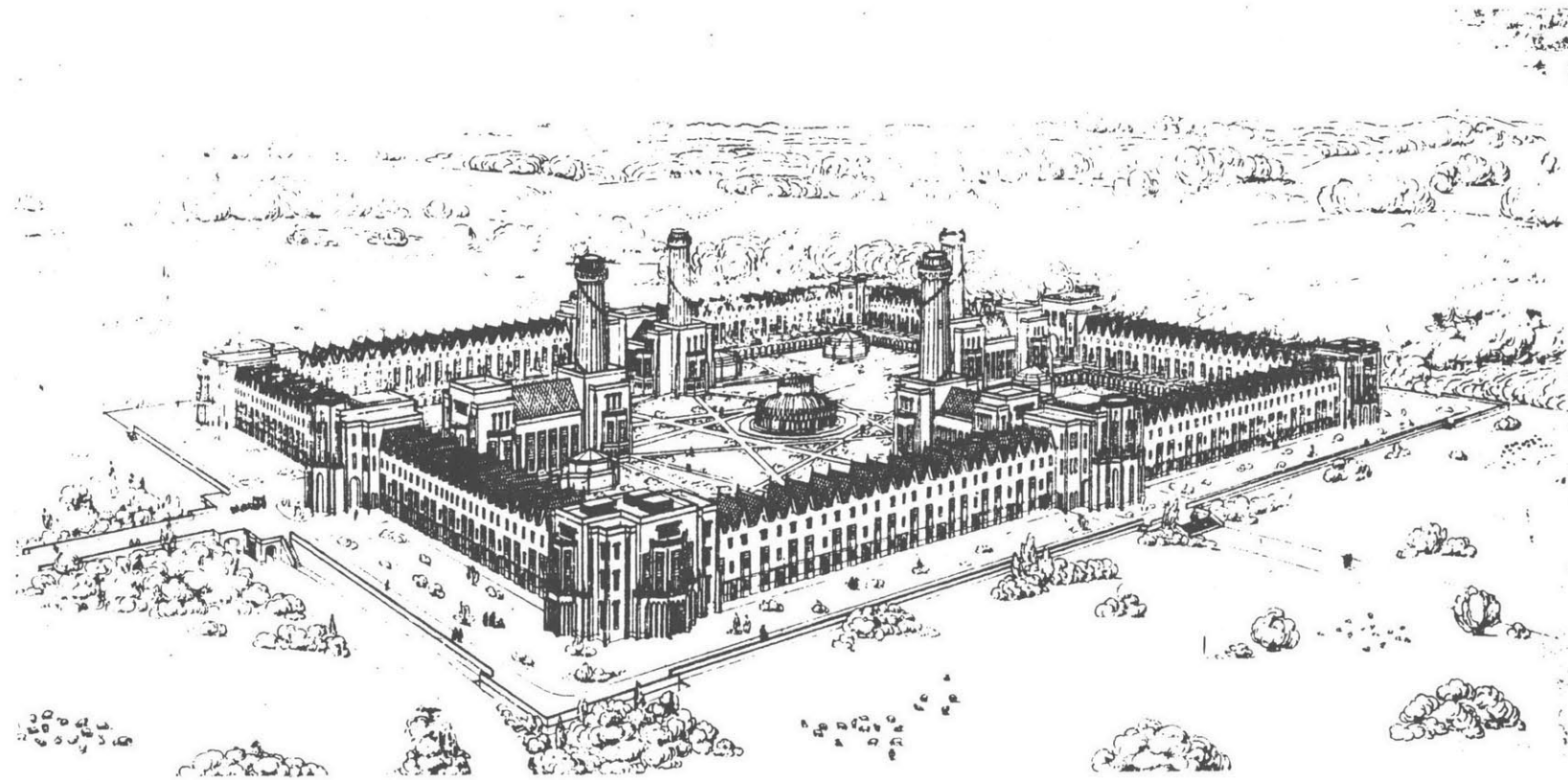
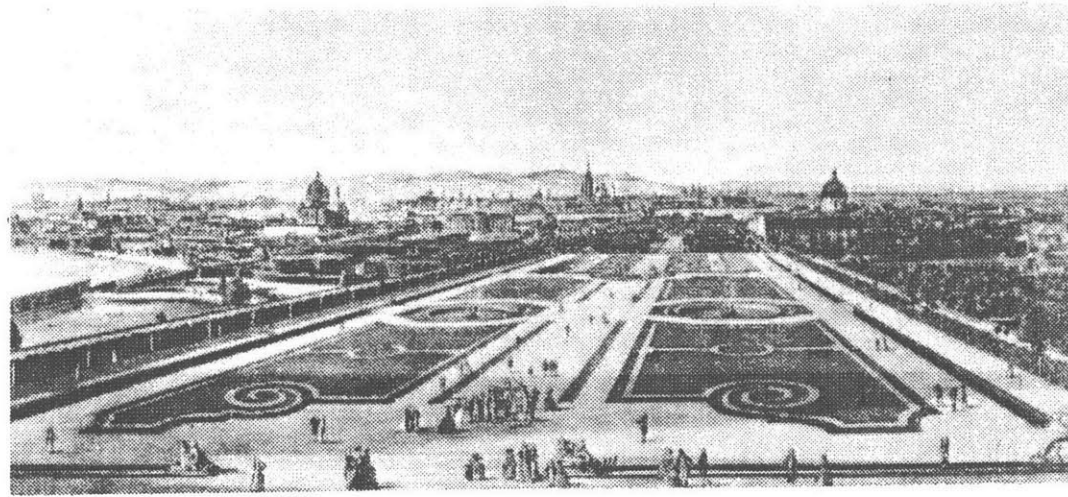

superseded any notion of continuity. Here, the true power of the surveyor is evident: not only can entire tracts of land be opened up to homesteaders, but radical interventions in an existing urban fabric can be undertaken. Though these attempts to control urban expansion both in terms of coordination and surveillance⁵ are intended to rectify an imbalance, they also propel the dynamic of building into an increasingly erratic and compulsive state. Our ability to transform the urban environment through building is met only by our ability to do so through demolition and abandon.

Despite the magnitude of infrastructural construction (if not because of it), large open areas in the city are not publicly accessible. Ownership patterns

Belvedere Gardens, Vienna, 18th C.

1825 engraving of Owen's progressive town to be built in New Harmony, Indiana.

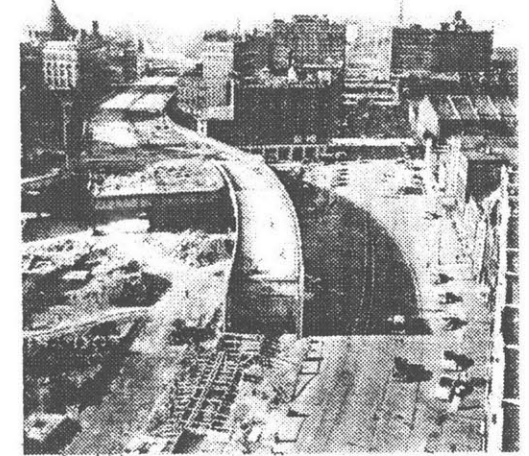
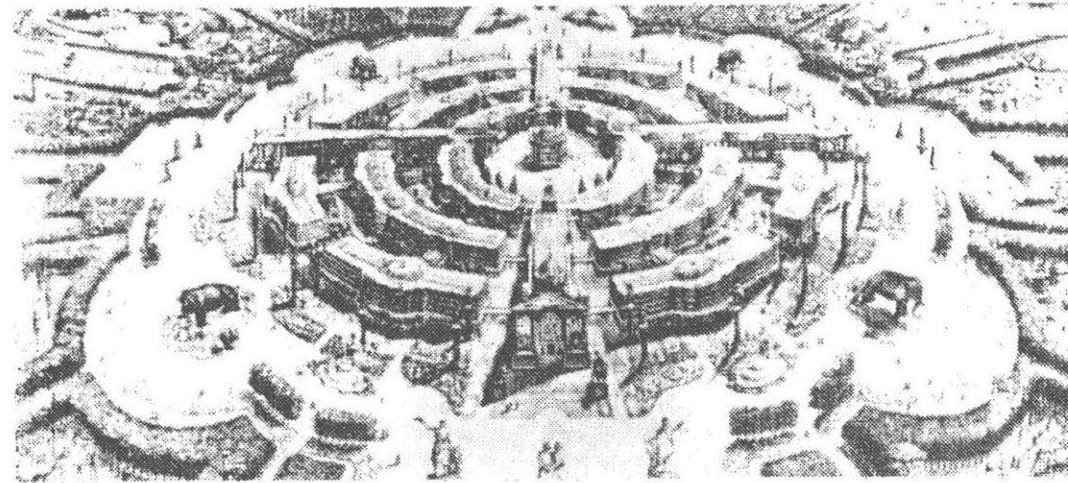

and zoning laws tend to discourage communal use of wide urban spaces as property values in the city are high and the specificity of use prohibitive.

Every urban dweller can certainly enjoy the freedom of moving through the city on the highway or public transportation. Yet as increasing demands are placed on the capacity of a city to allow for more traffic at higher levels of fluidity, the city becomes at once connected by its roads and de-compartmentalized by them. Decentralization of the whole and concentration of parts have lead more to discontinuity in the urban fabric than to an integration of it. The modern counterpart to the medieval square is only to be found temporarily at large-scale events which instead of transforming

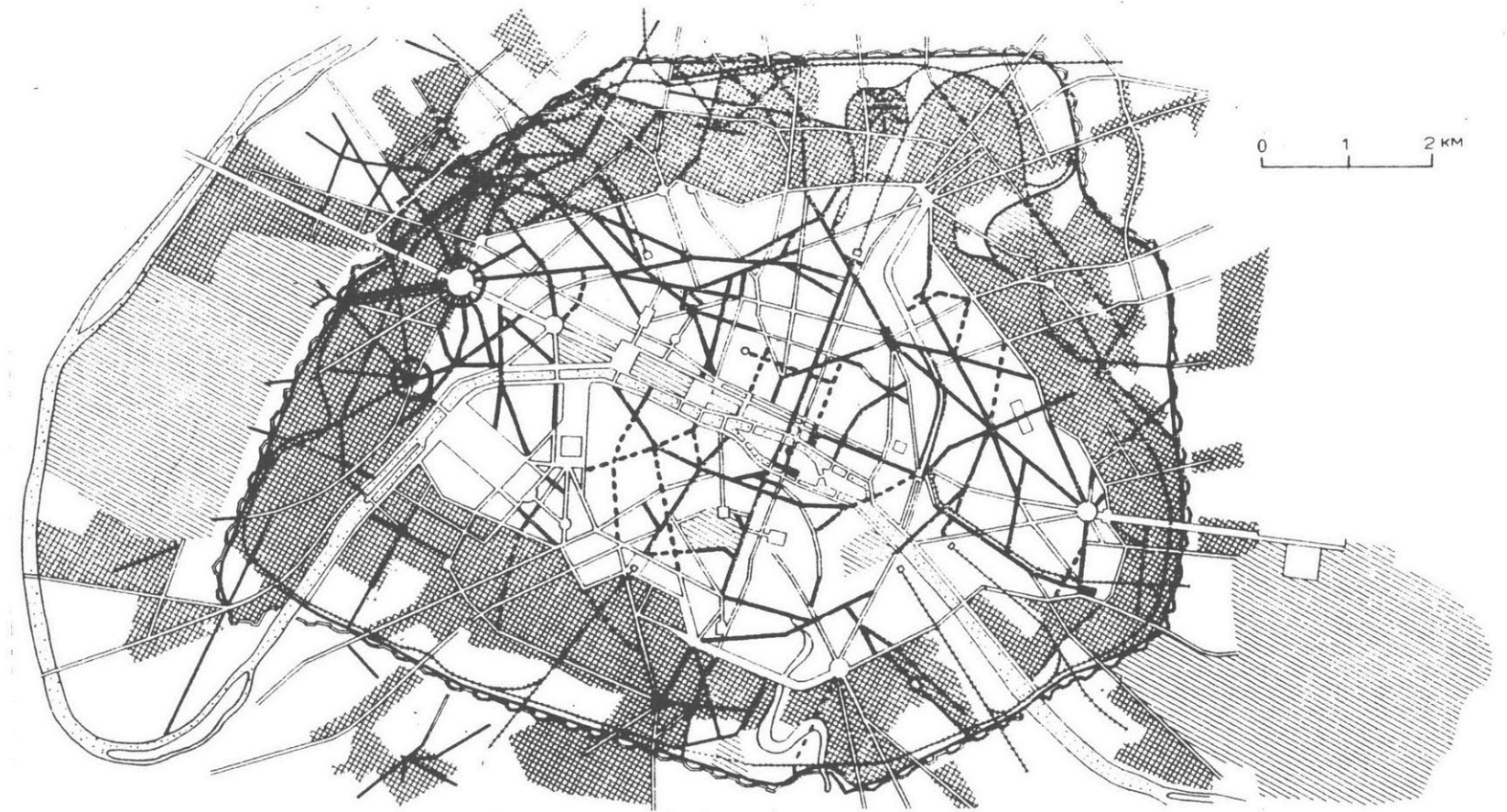

Project for an ideal community by Andre, mid 19th C.

Hausmann's project in Paris.

Building of the Central Artery in Boston, 1950's.



common space in the city, preempt normal functions on a short term basis. Thus, while urban infrastructure breaks down spatial and temporal boundaries in the expanding city, large open areas which can support a variety of public events and embody a sense of communal place are rapidly disappearing.⁶

Simultaneously, places in cities which can be characterized easily by their lack of intention are produced by default. Marginal areas where large infrastructural elements predominate (highway intersections, bridges, railway lines, canals) tend to create open spaces within the city. Regardless of their history, they elicit a suspension or erasure of a predetermined programmatic image. They maintain a void of specified intention and embody a

Chicago suburb.

Downtown Chicago.



potential to occupied without precondition. It is the abandoned building to be occupied by squatters or demolished, the vacant lot in any suburban neighborhood where children can engage in activities not normally condoned at home; it is the duty-free zone of a city which takes on the function of an inner-city frontier in the urban psyche.

These places tend to collect the fallout of architectural production, that which reflects the incompleteness of urban design by receiving that which has not been accounted for: all those activities which fall outside the master plan. Such zones can play an important role in the city apart from providing a refuge for the unwanted or a playground for the illicit.

One can design for these sites

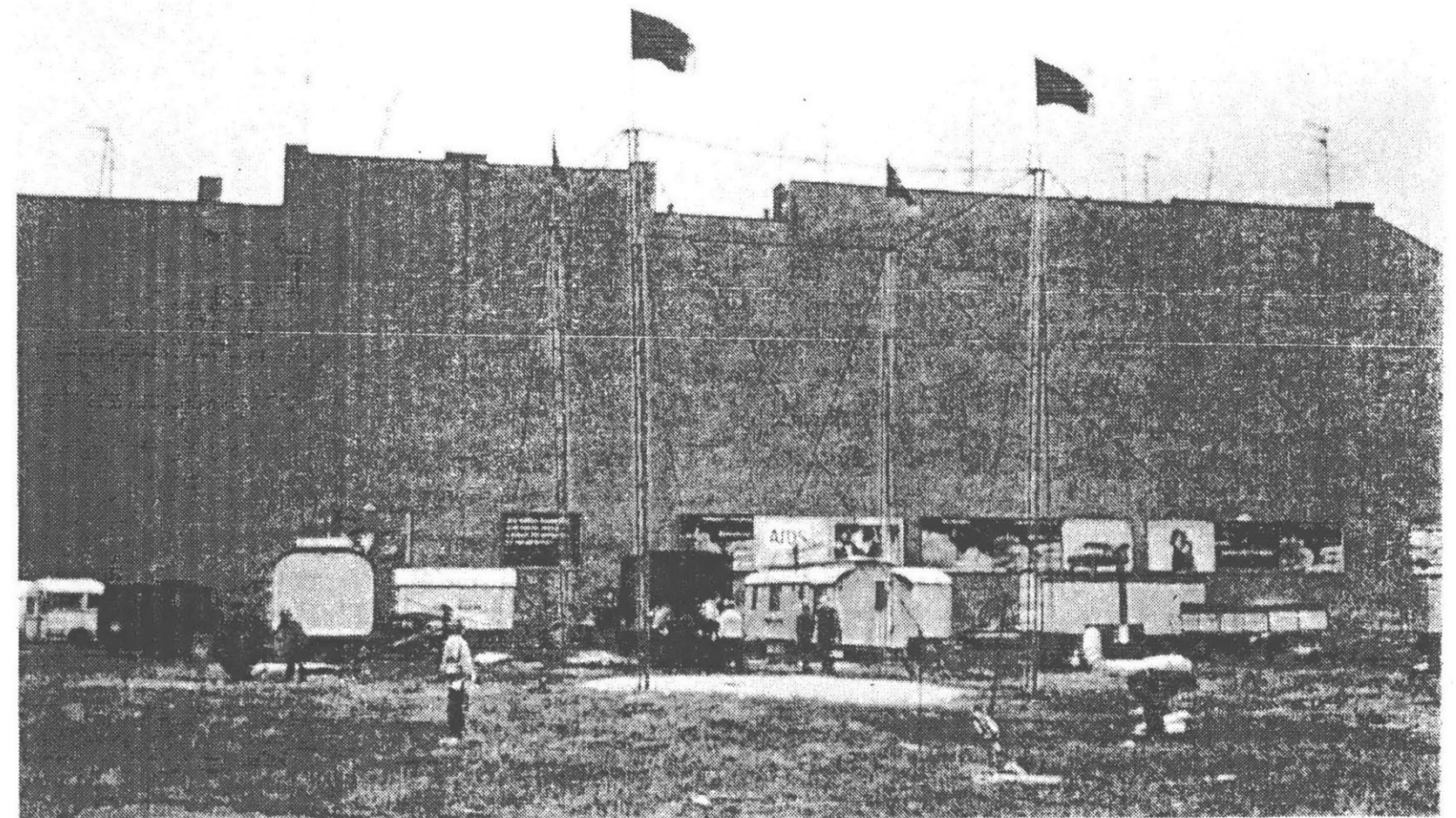

Berlin Wall.

Berlin as seen by Wim Wenders in "Wings of Desire".



so that the potential of the urban frontier is developed without being destroyed through permanent occupation. As an abstract cultural boundary, the frontier marks adjacency or being located beyond. It cannot truly be reached.. For as soon as it is inhabited, it loses its character as a frontier. The urban frontier is more a multi-functional space for a variety of events to take place only to be succeeded by another. It has a transient architectural agenda, a potential for a multiplicity of activity and a resiliency for returning to its original state. The program can be regarded as a set of possible events more than a set of functional requirements.

Nonetheless, an infrastructure for the frontier is required, one which is capable of supporting a

I don't believe anyone will ever be able to make any city council understand that from an urbanistic point of view, the most attractive parts of the city are precisely those areas where nobody has ever done anything. I believe a city, by definition, wants to have something done in those areas. That is a tragedy."

-Wim Wenders in a conversation with Hans Kohlhoff, Quaderns #177, Barcelona, 1988.

From "Wings of Desire".

multitude of public events without allowing any single one to predominate. Each participant would survey the site as new territory to be charted and settled. The physical nature of inhabitation would be a function of the occupant's "reading" of the site. Each event would have its own particular configuration but would not leave any traces.



¹ Benevolo, L. *History of the City*.

Cambridge: MIT Press, 1988, chs. 4,6,7.

² *ibid.*, p. 501

³ Lefebvre, H. *The Production of Space*.

Cambridge: Basil Blackwell, 1991, p. 7.

⁴ Benevolo, L. *The Origins of Modern Town Planning*. Cambridge: MIT Press, 1968, p. 10

⁵ Nijenhuis, W. "City Frontiers and Their Disappearance", *Assemblage 16*, Cambridge: MIT Press, 1992, p. 43.

⁶ Nicolini, P. "Urban Identity and technical Infrastructures," *Lotus International #59*, Milan: Electa, 1988.

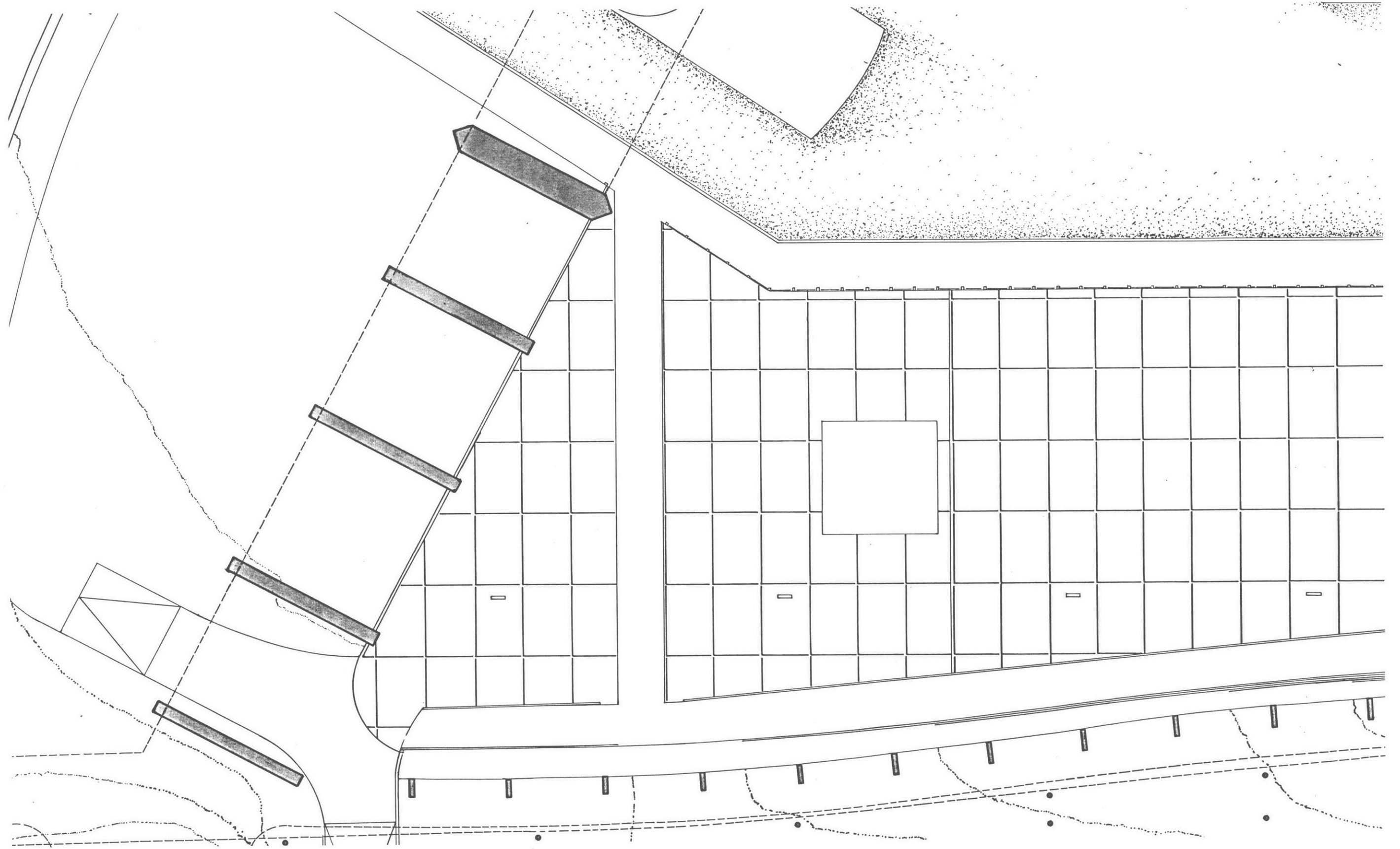

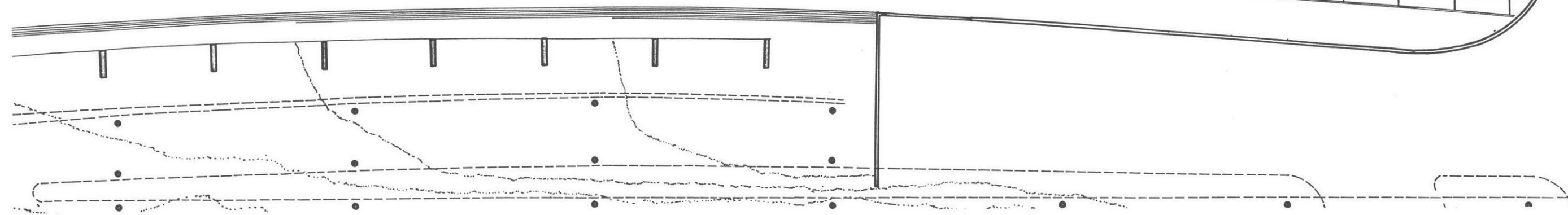
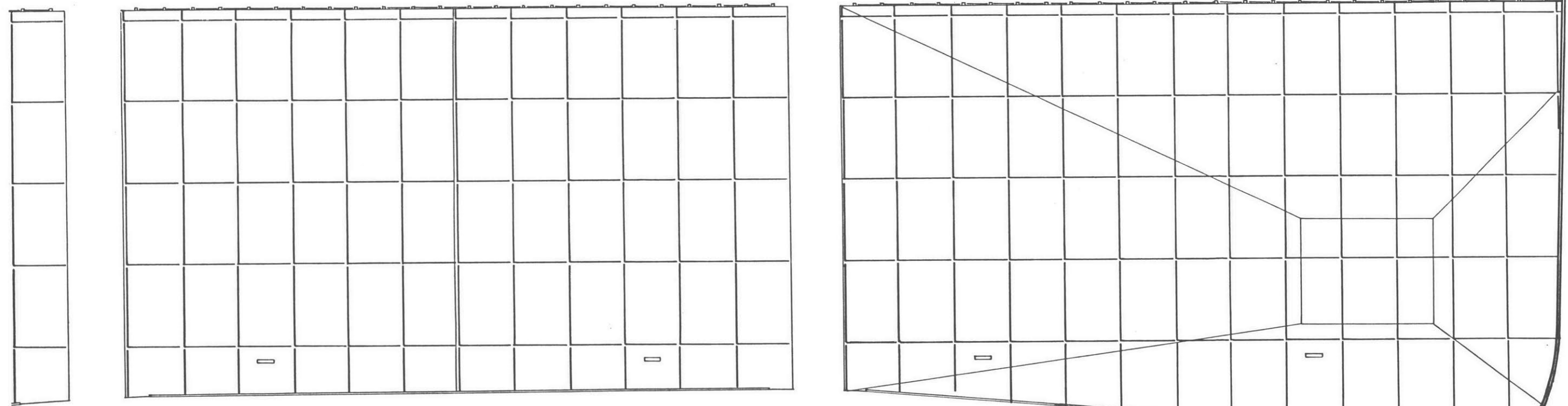
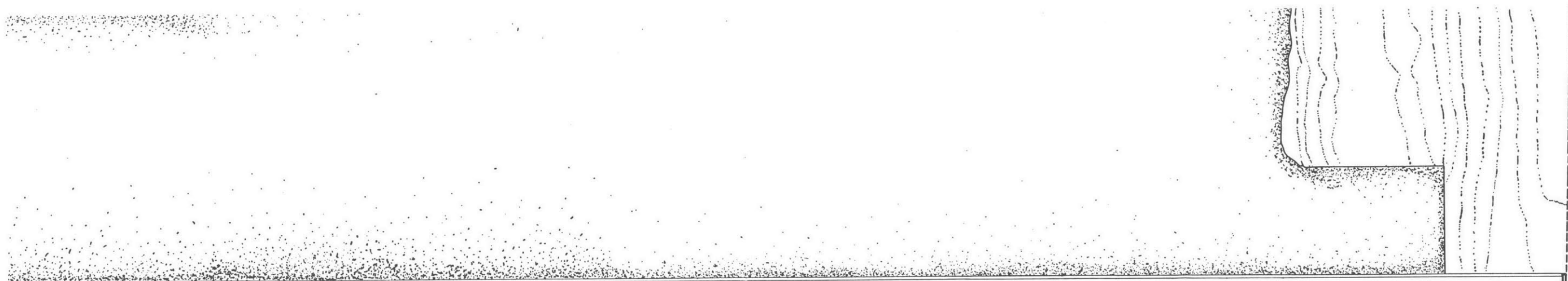

DESIGN

The design of the project can be divided into three phases: intervention with and transformation of existing site features, establishing the general layout of the frontier, and finally, the design and implementation of site specific infrastructure. Throughout the whole process, the architectural agenda of supporting multiple programs based on large public events was latent. It served to establish plausible dimensions in designing both the transition from the city to the site and the terrain of the frontier itself. Generally, the strategy was to employ existing elements of urban infrastructure as an armature for new interventions. Together, the pre-existing and the "designed" would work to give the site an overall coherence on a global level. Yet

Sketch models, 1'=1/100", 1' = 1/40"

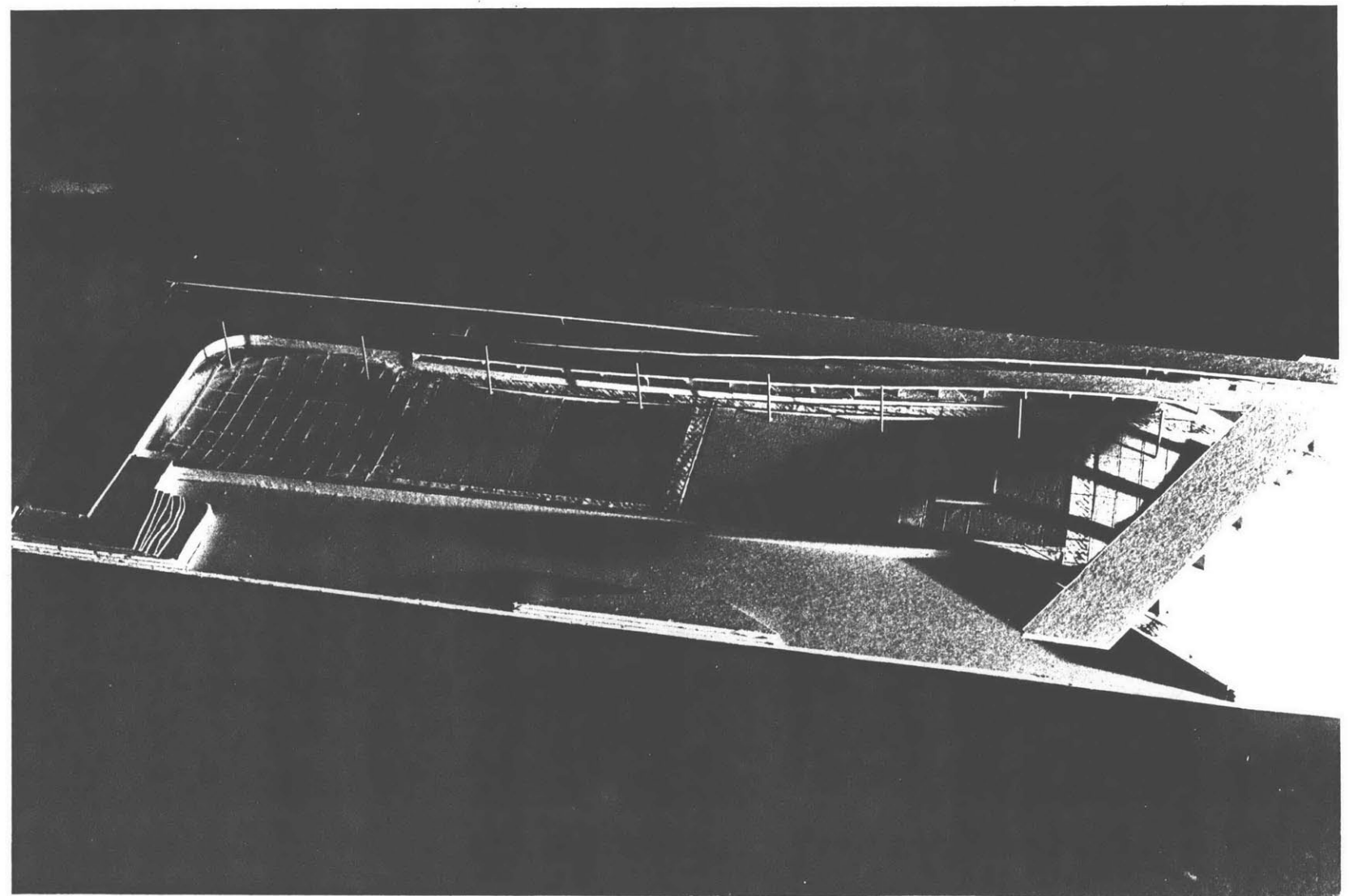
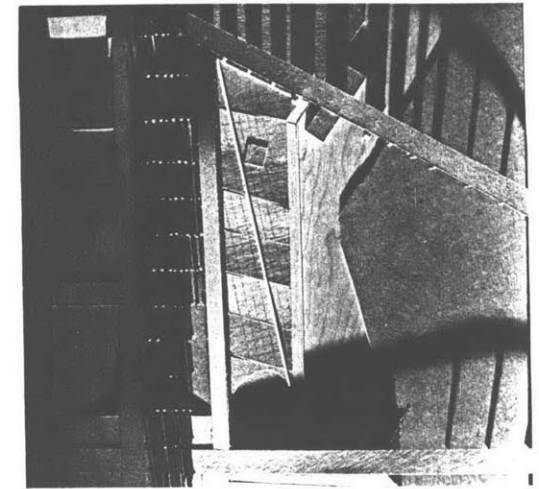

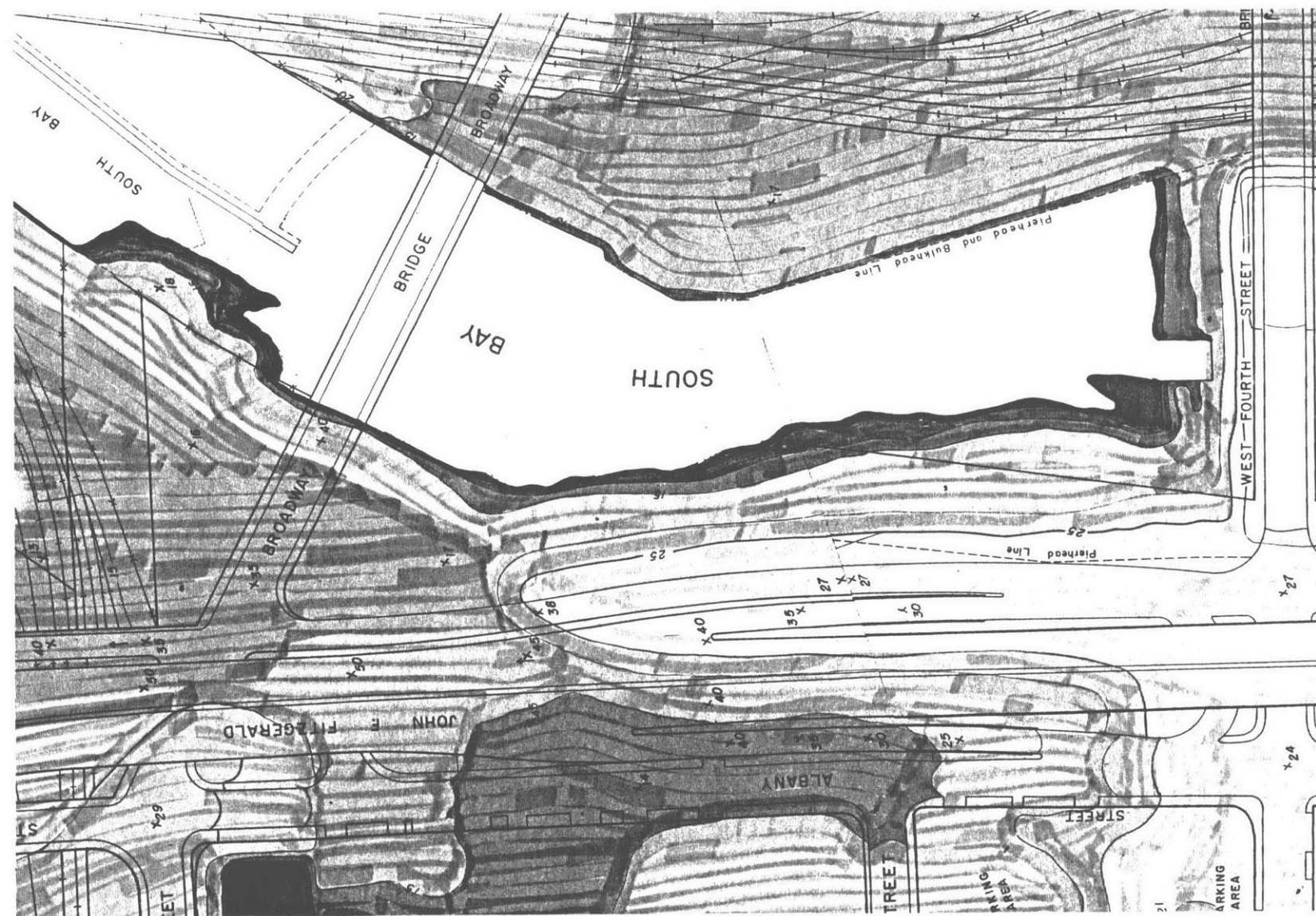
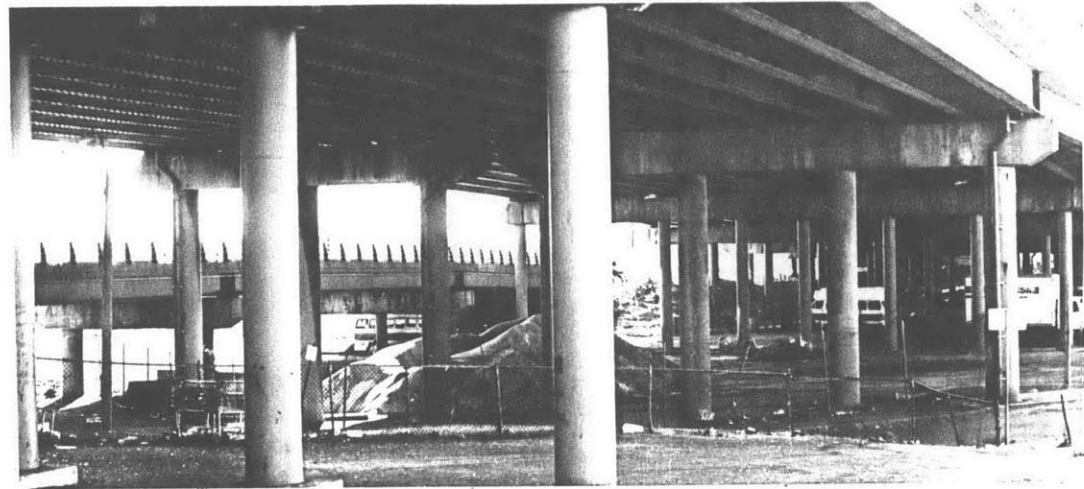

in investing the infrastructure needed to fulfill the frontier's programmatic requirements with a specific, built nature, the site could be readily inhabited and transformed on a local level. As soon as a truck farmer parks his truck and displays his goods and a vendor plugs in his kitchen, that location becomes a market until they leave.

As a frontier, the site is conceptually unapproachable. It is adjacent to or beyond civilization. One can near its edge and view it, but never occupy it. In order to maintain and emphasize this aspect, the initial phase of design dealt with overall legibility and access.

Firstly, a high seawall with an embankment along the Channel roughly following the flow of water from the culvert at its end

Existing site topography.

was designed. This provided a clear counterpart to the wall formed by the Central Artery and extended the site through landfill.

In a similar fashion, the northbound service road immediately adjacent to the site was redesigned to emphasize the character of the highway as a permeable wall and threshold between the city and the frontier. To this end, the road was elevated and supported by a series of pylons. The space underneath it was enlarged through excavation such that it could be used for access. A retaining wall following the curve of the service road formed a clear boundary between the sheltered space below 93 and the open space of the frontier. Between this wall and the pylons, a paved promenade along the site was added where one could

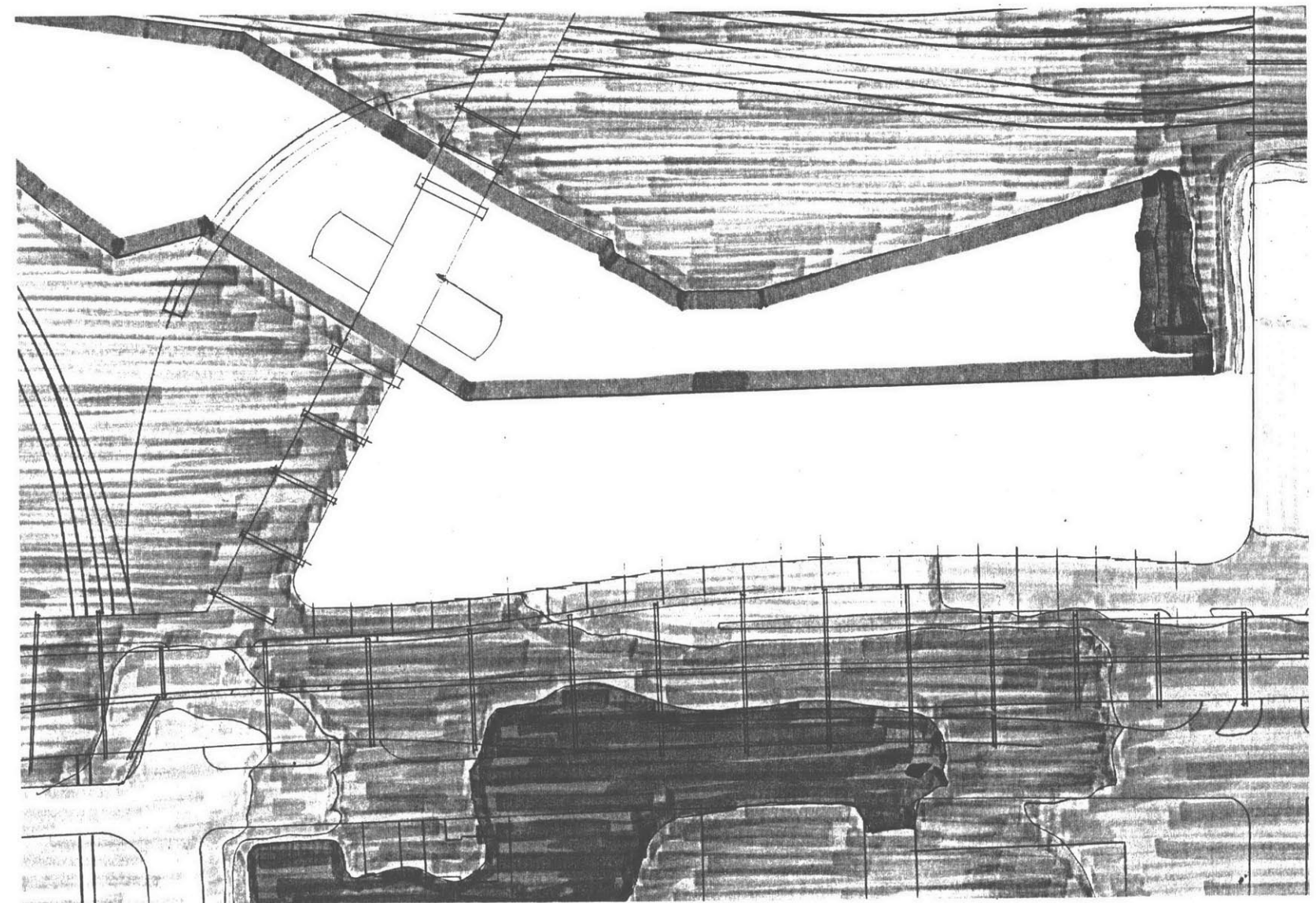

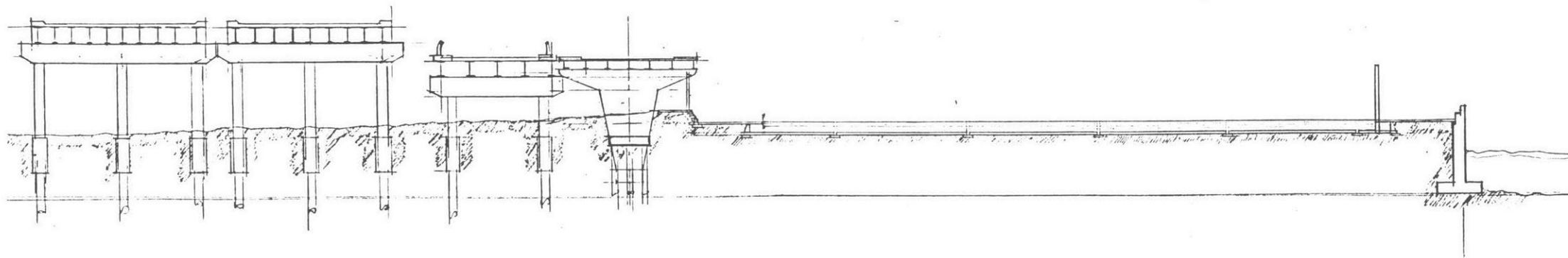
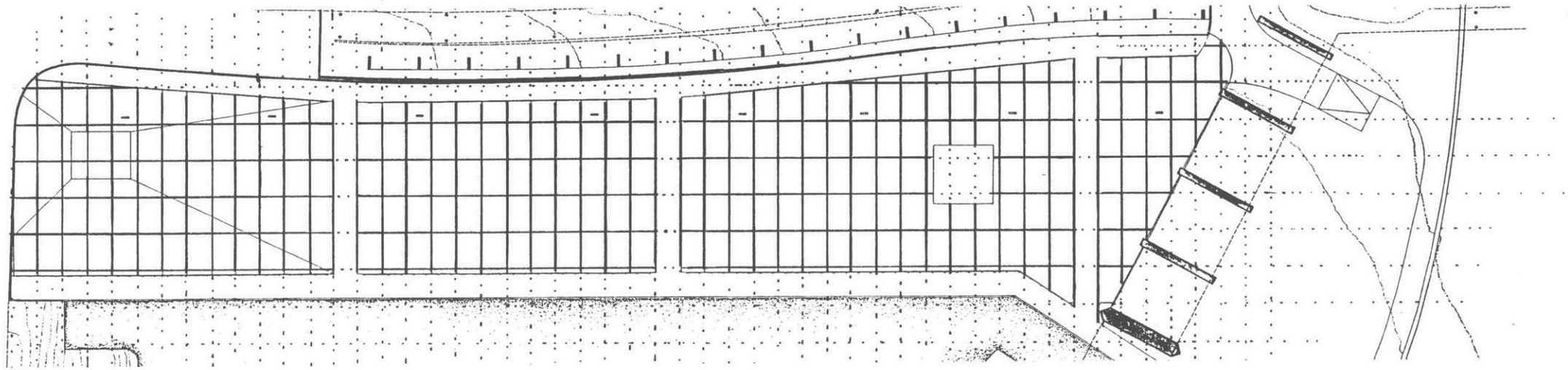
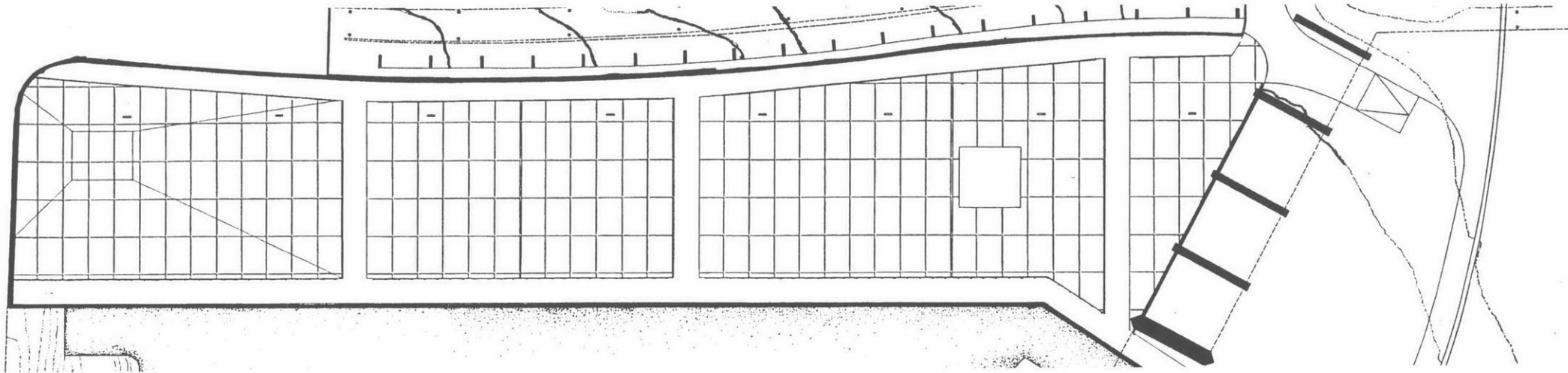

Boundaries.
Concrete slab grid.
Section.

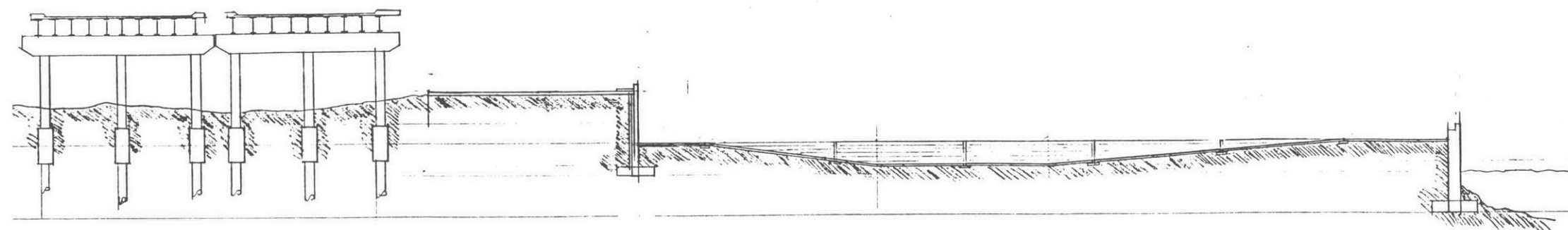
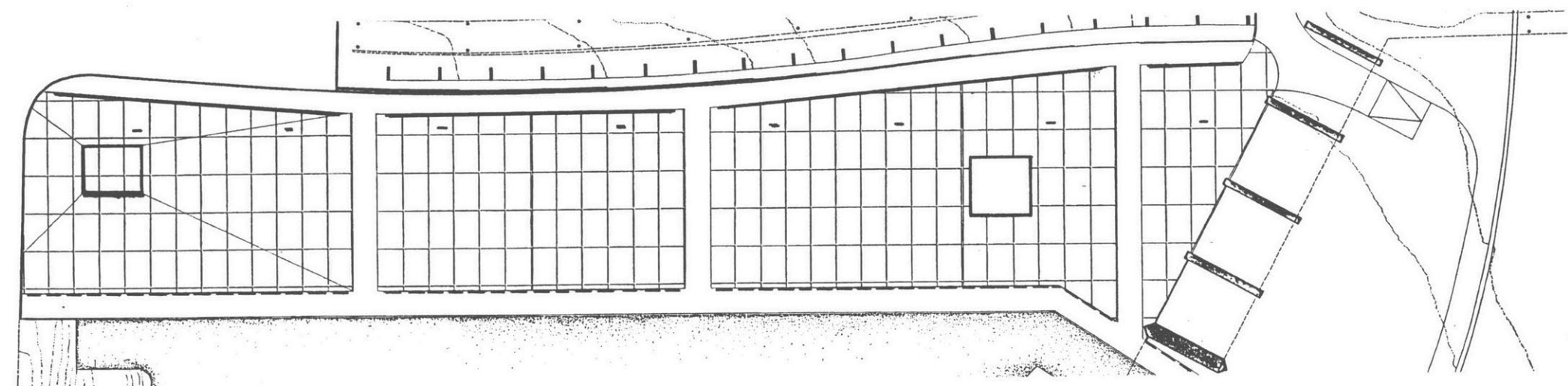
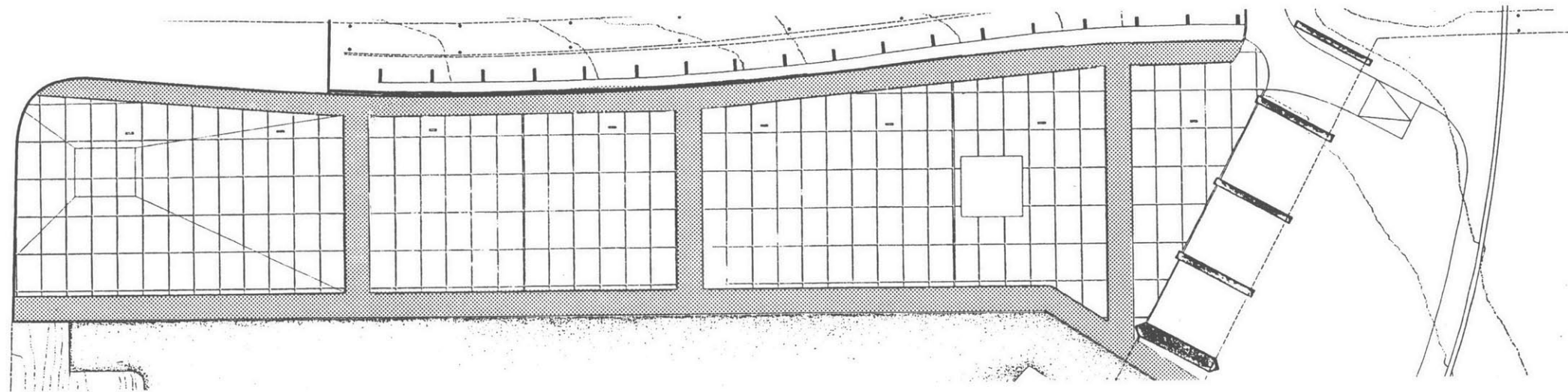

Circulation.

Infrastructure.

Section.

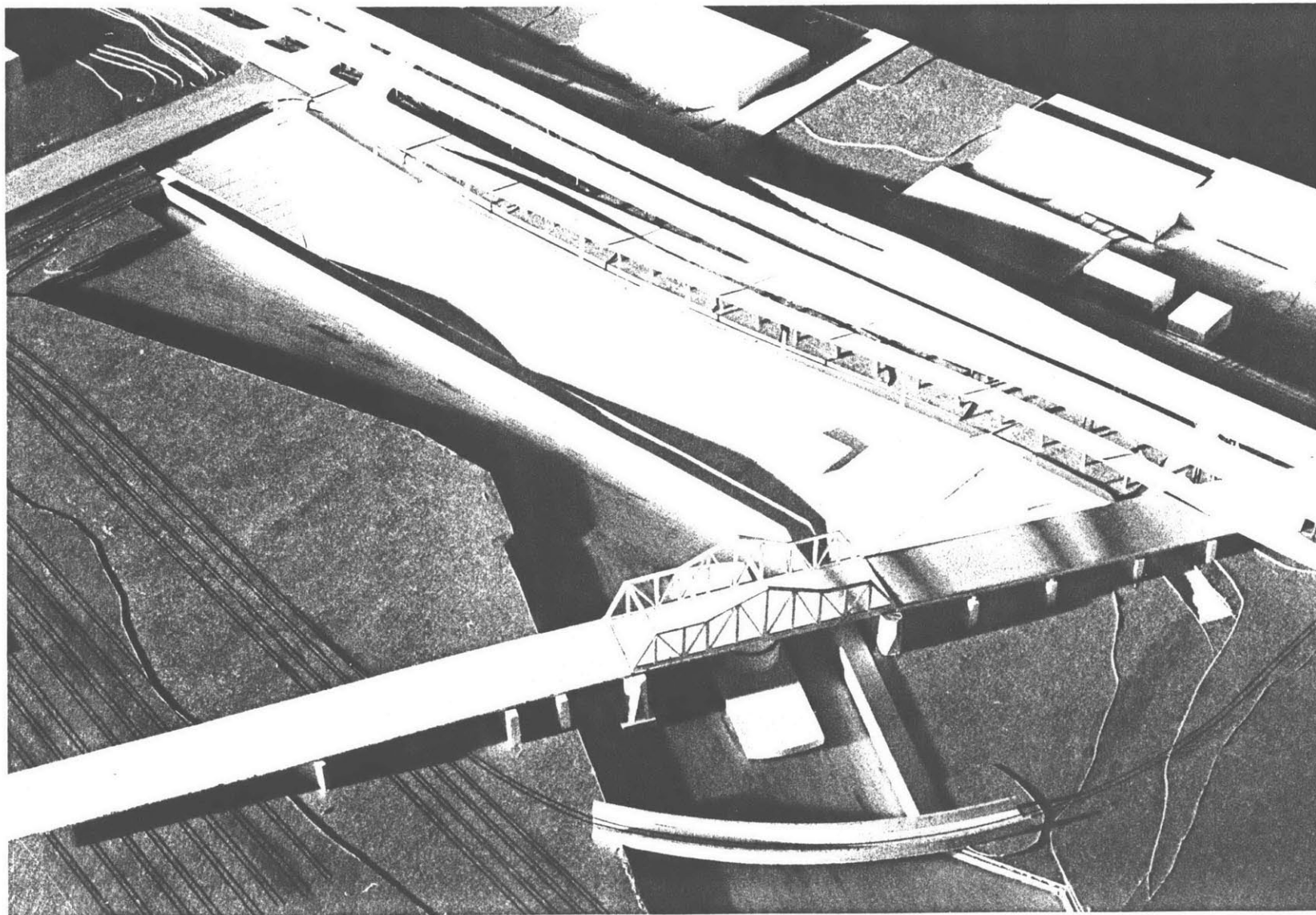
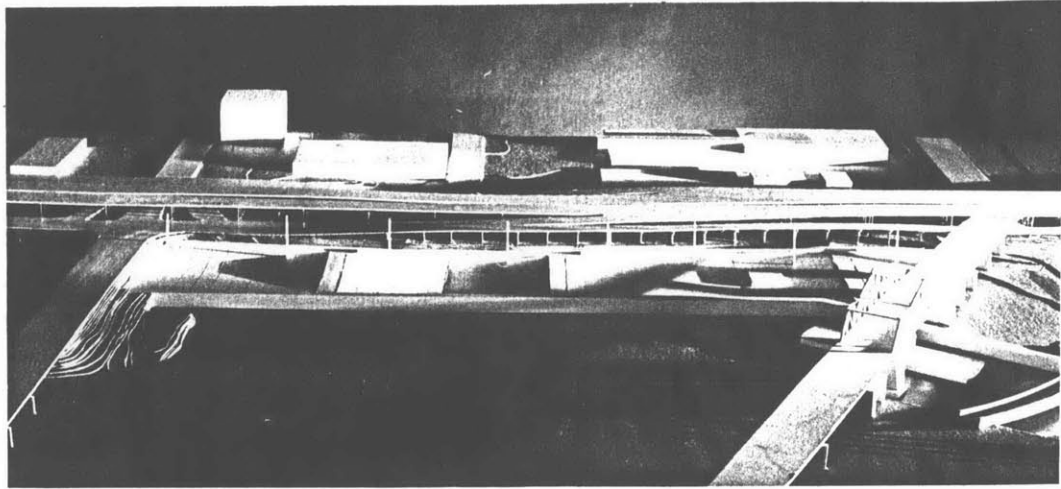

survey it without entering onto it. Access could then be gained at any point along this wall by means of a temporary stair or ramp. By employing the existing material nature of the highway and the space it creates to allow for inhabitation and access, the perception of the highway as a mere surface projection cut out of the ground plane is altered, investing urban infrastructure with new meaning.

The frontier, as both myth and geographic location, precedes civilization. It is the apriori condition to settlement. It has no spatial hierarchy, only geographic features. Ideally, anything can happen anywhere. The nature of inhabitation determines specificity of place. Conceptually, the frontier lies beneath civilization; successive layers of urbanization

Model 1' = 1/40"

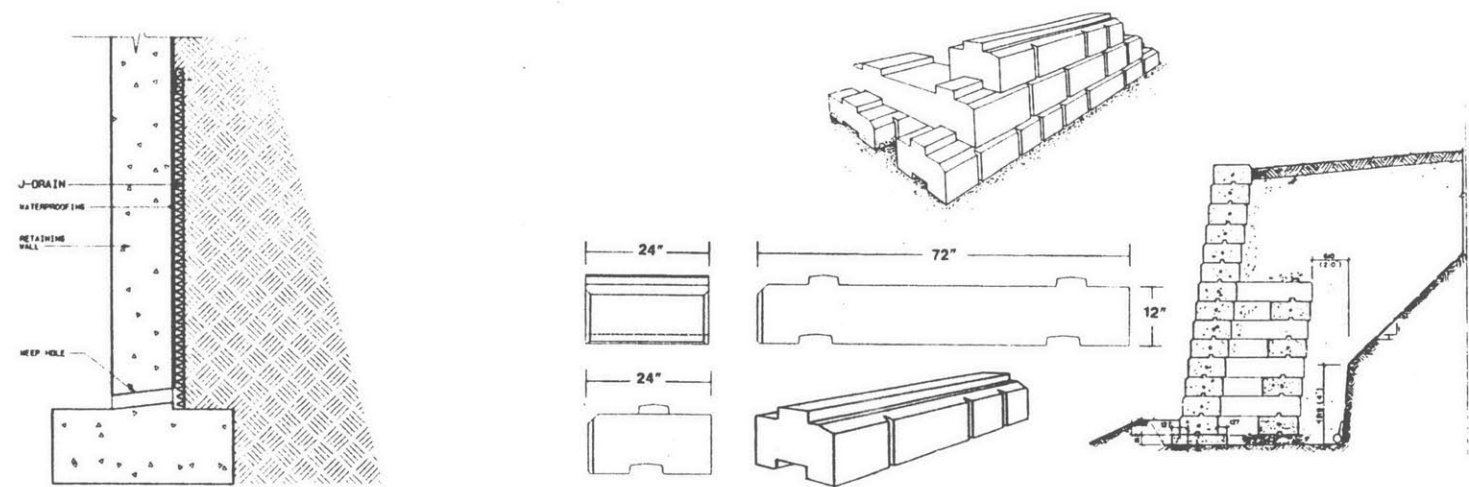

cover it. Between the natural landscape and the architectural program which is mapped onto it, lies the city. Only a fictional, projected order, foreign to adjacent ones, can be placed on the frontier.

An undulating grid built of 20' x 30' concrete slabs provides the continuous surface across the length of the site. It is flanked on the east and west by access roads which conform to the retaining and sea walls respectively. When the grid rises to the level of the access roads, connecting roads are established such that movement from outside onto the terrain of the actual frontier is controlled by syncopation. But once on the grid, pedestrian and vehicular movement is unimpeded. As one moves up and down, across the site, one

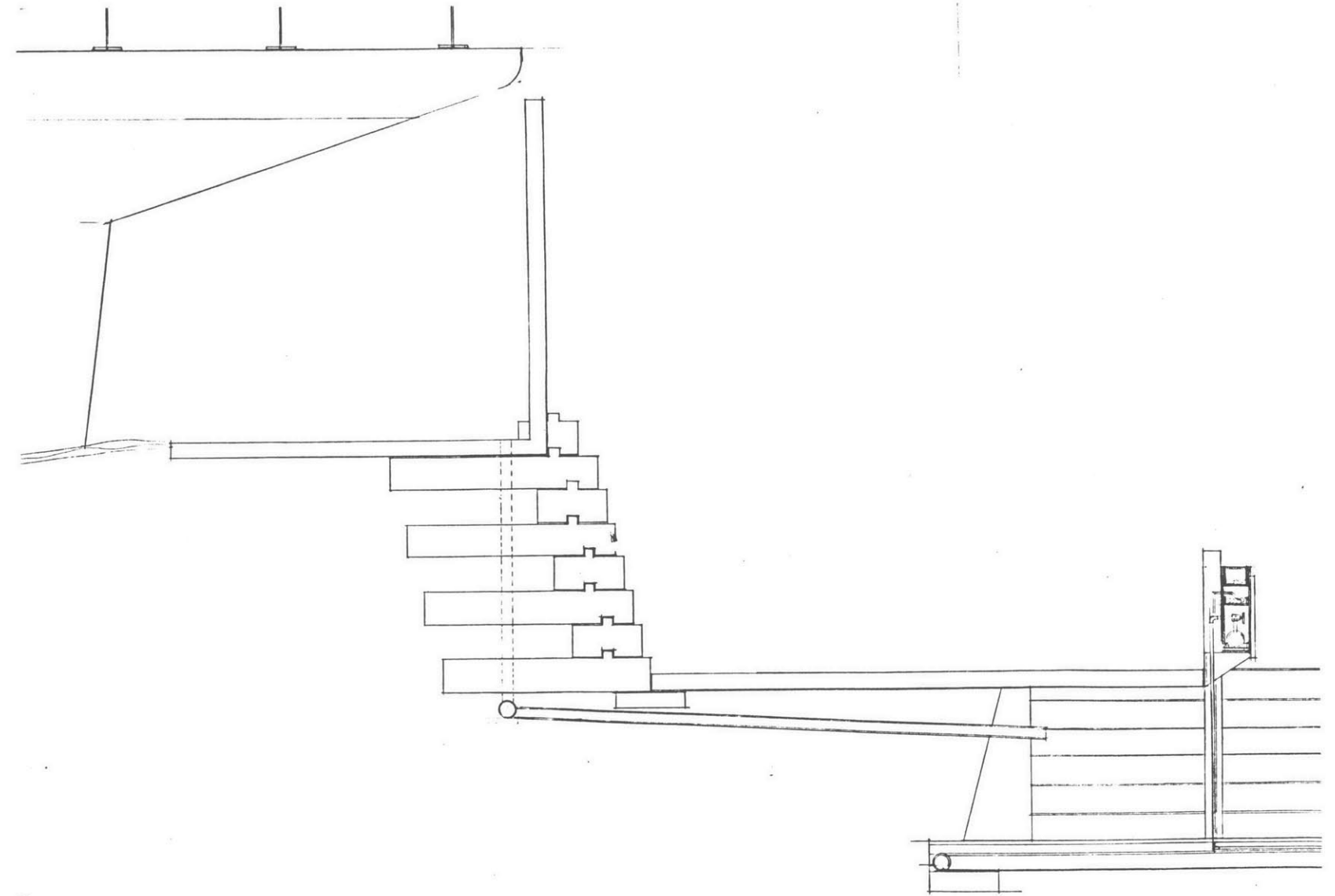

Retaining wall system.

Section of site along Highway 93.

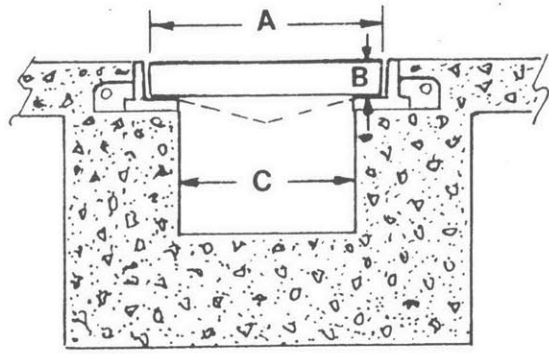

A = Grate/Cover Width
 B = Edge Thickness
 C = Trench Width

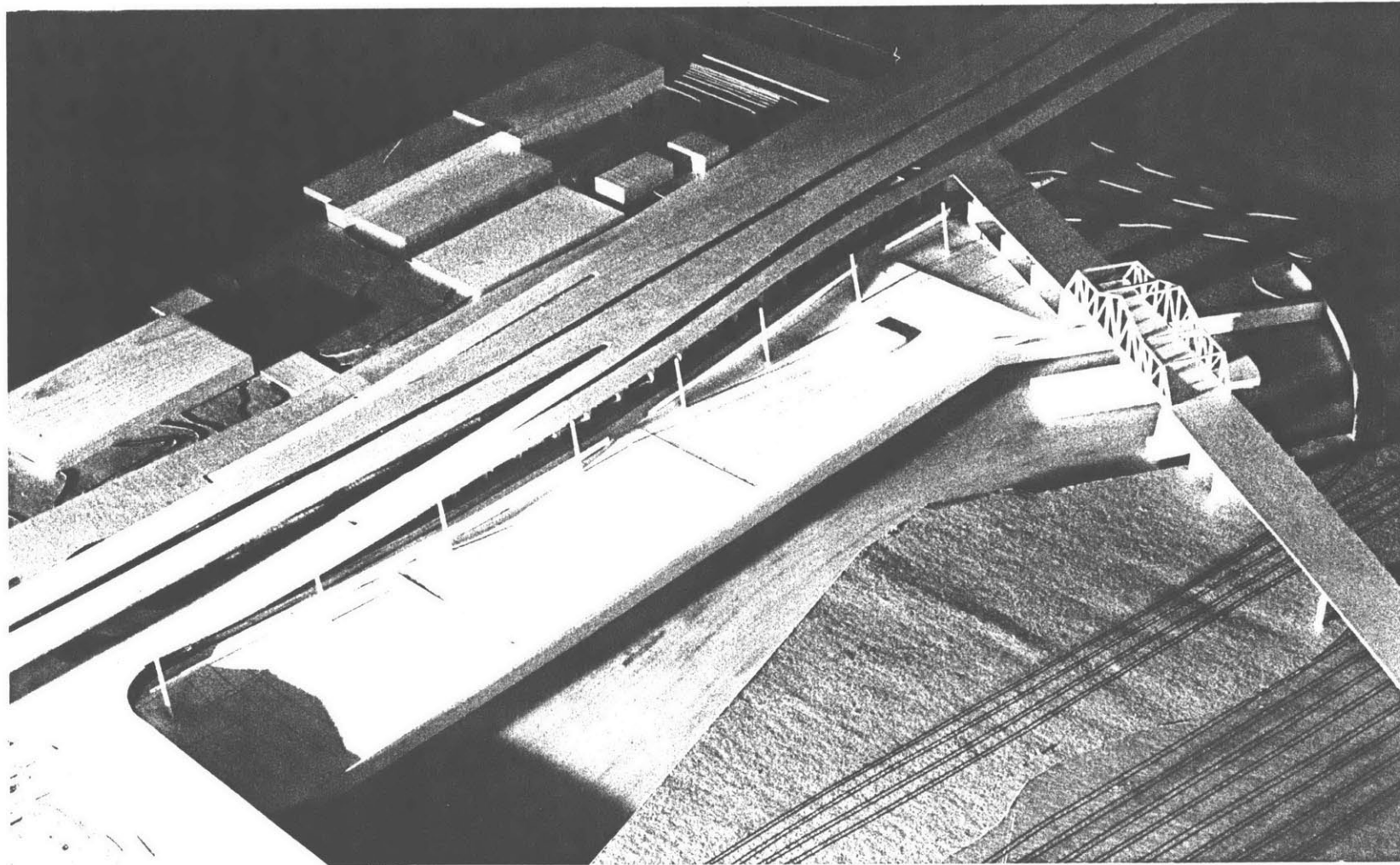
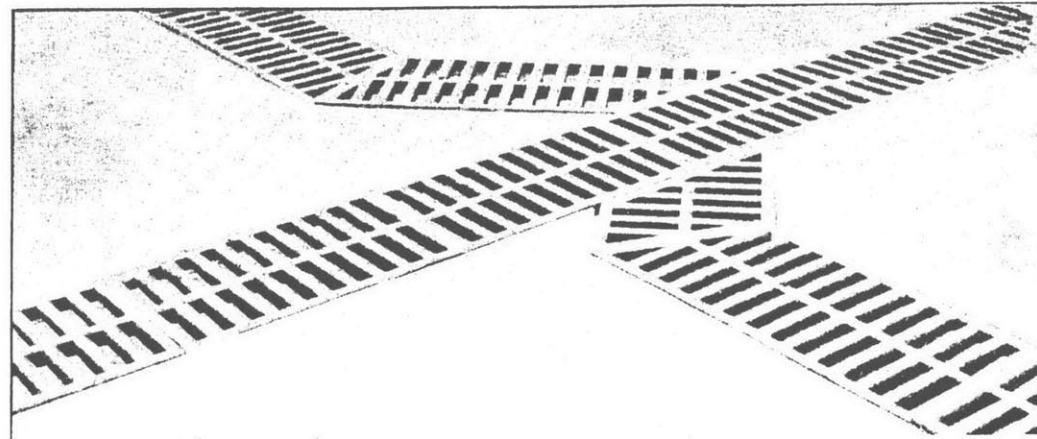

inhabits a particular part and then gains the overview at a connecting road only to descend again.

The main infrastructural features of the project are: an elevated platform (stage) to the north, a utility viaduct running along the eastern access road, a row of tall light poles extending the length of the site, and a depression to the south which acts as a counterpart to the platform. The viaduct carries power and water to all parts of the site by means of secondary channels which run between the slabs.

When viewed overall, the site appears to be comprised of patterns generated by the various elements of the project. These in turn are off-set by the specific nature of the large elements: the

Drainage system.

Model, 1' = 1/40"

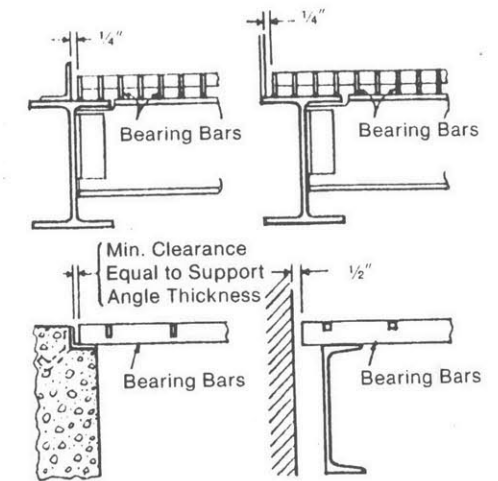

platform, the viaduct, the light poles, etc. But when viewed locally, the specificity of each element as pattern or object is called into question. The concrete slabs are both discrete material entities and fields of the grid. The viaduct functions as a linear element across the whole site, but also has the scale of a water faucet. At the same time, it is both a handrail and a wall. The retaining wall is made of pre-cast concrete units which provide armatures for temporary stairs or ramps, but through repetition form a tight pattern.

By utilizing mass produced materials on this scale and simultaneously investing them with a specific character that fulfills several functions, the project comments on the material nature of architectural

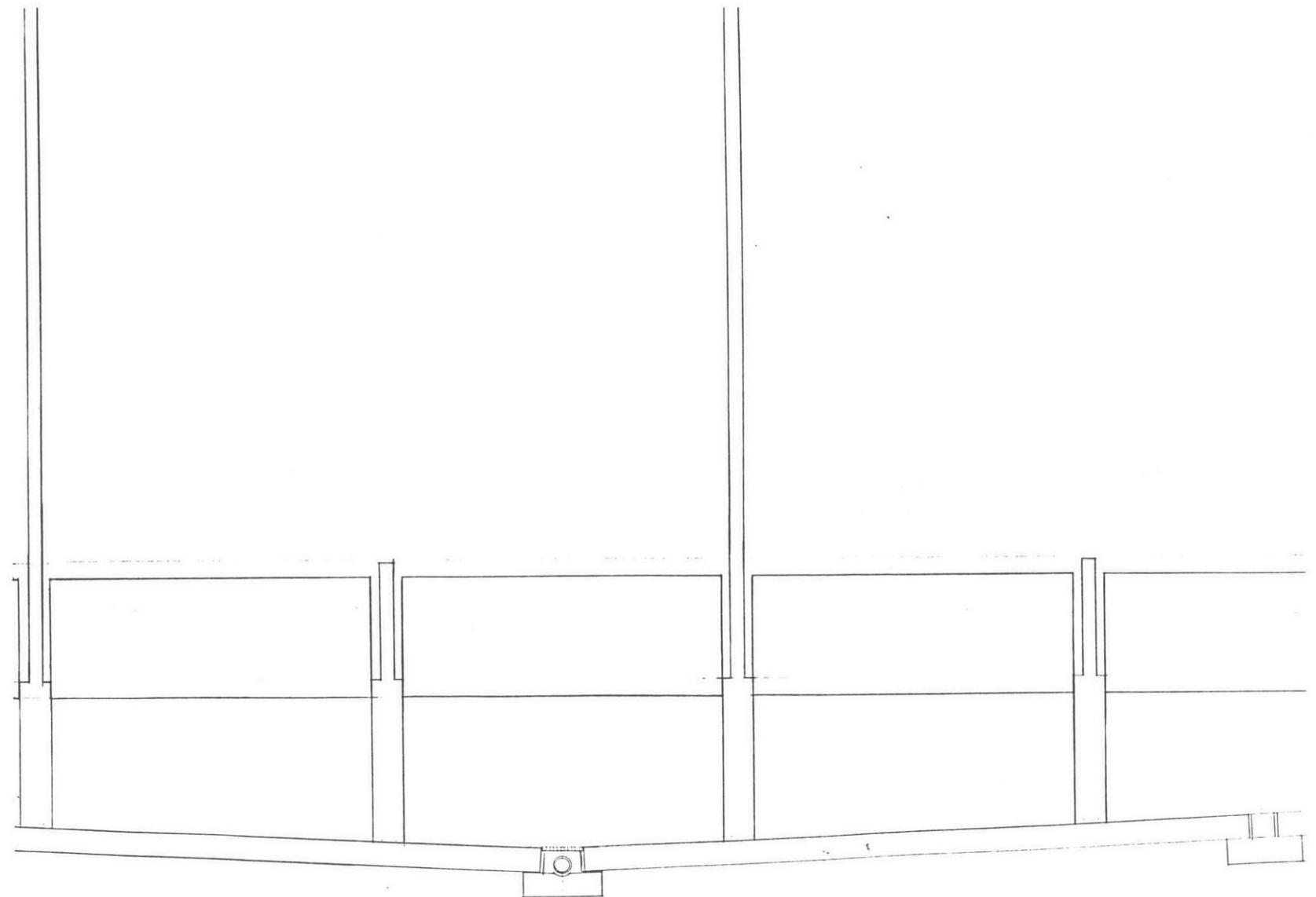

Detail of grate system.

Embankment wall elevation.

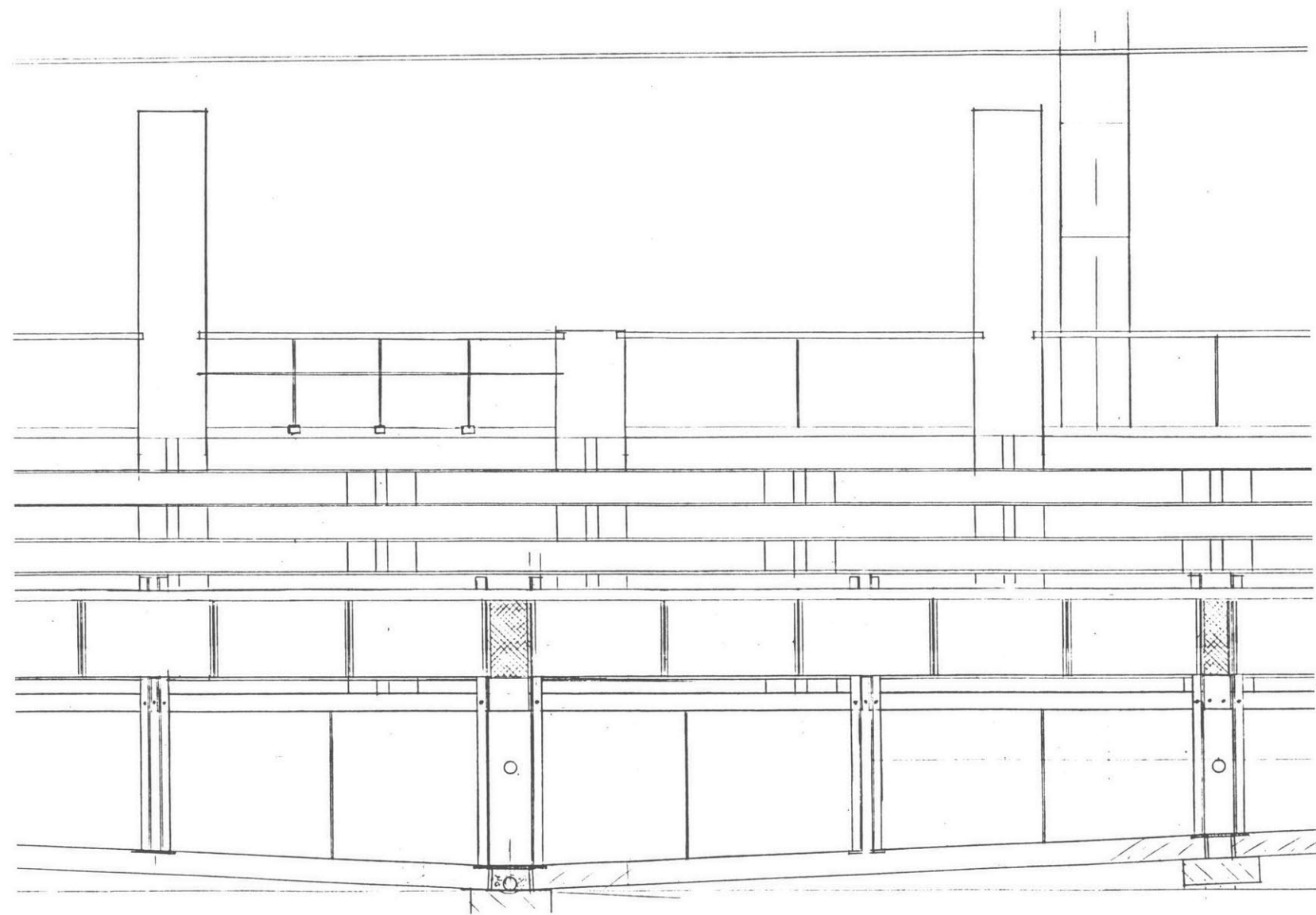

form.

Retaining wall elevation.

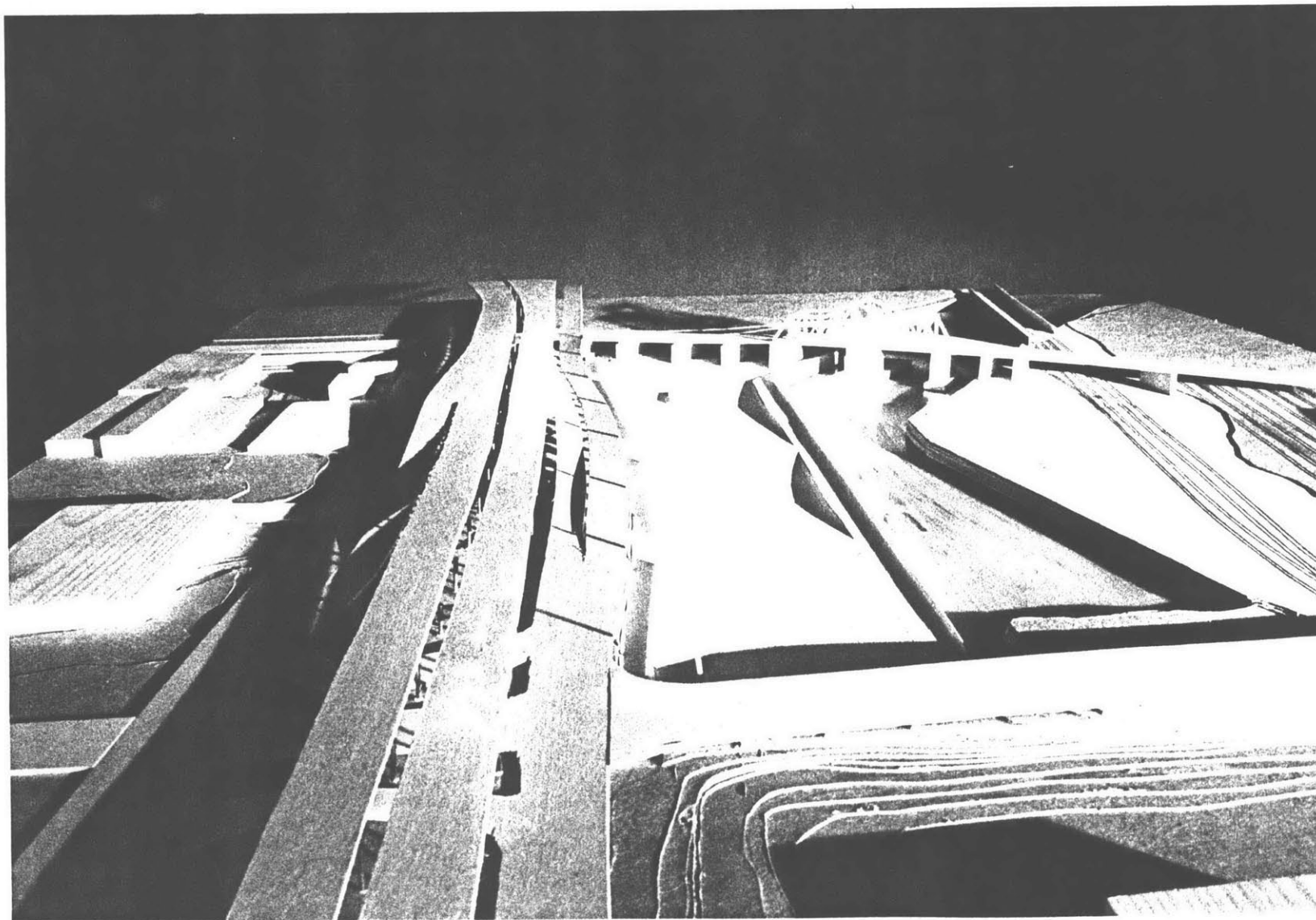

PROGRAM

Ranging from the space between two chess players to that of a fairground, the spatial and temporal requirements of multiple programs constitute great shifts in the scale of inhabitation. With only a chess board as an interface, the space of a chess match is concentrated and intense, introspective and self-contained. Yet that of the fair is constantly changing as groups of people move, congregate, and disperse depending on the focus of attention.

A pattern of inhabitation is created by the way the programs overlap. As long as the infrastructure of the project meshes with this pattern, no programmatic hierarchy is created and the site can be completely vacated following an event, returning to a frontier.



Swap Meet

Spatially organized by small, equal lots spread across the site, the size of the swap meet or flea market grows incrementally as people arrive with their goods. Whether they simply spread a blanket on the ground or open up the back of their truck, each vendor has equal exposure along an alley and access to utilities in the channels.

The public would arrive from as many gates as are needed along the retaining wall. There, one could view the site before entering and choose where to begin. Once amongst the vendors, one moves back and forth between the retaining wall and the embankment which points to the edges of the site while offering changing views of the city as one turns up or down the project.

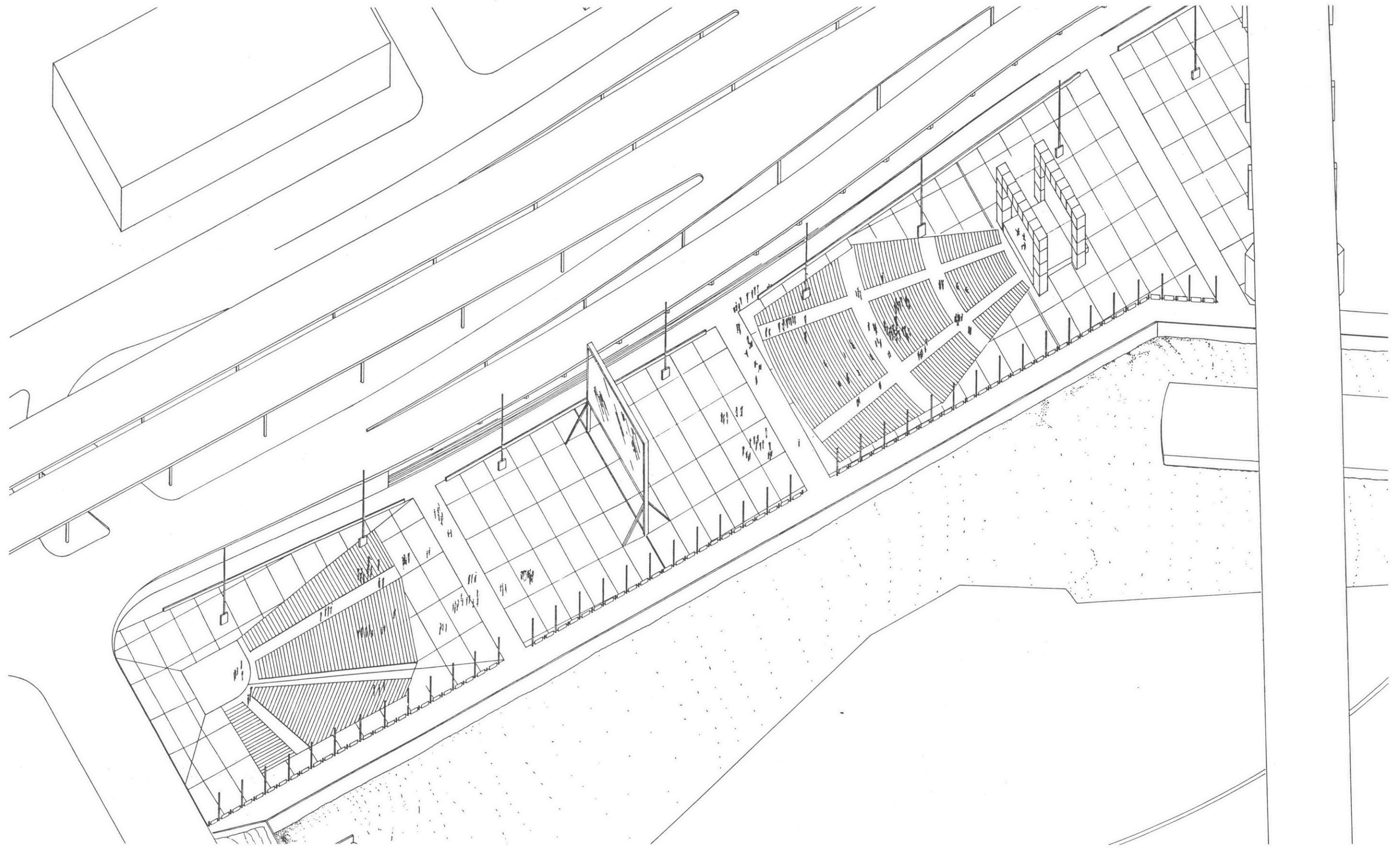

Concert

The gentle grade change of the project would allow for concerts or theater to take place at the low points of any of the three sections. The raised platform on the northern most part could become the stage space for an audience of up to about 100 rows of normal seating. The audience would watch a performance where the site is surrounded by highways and the view of the city obstructed.

At the other end, the faceted ground plane sets up a space resembling an amphitheater where the performer has the most commanding view of the city with the skyline as a backdrop.

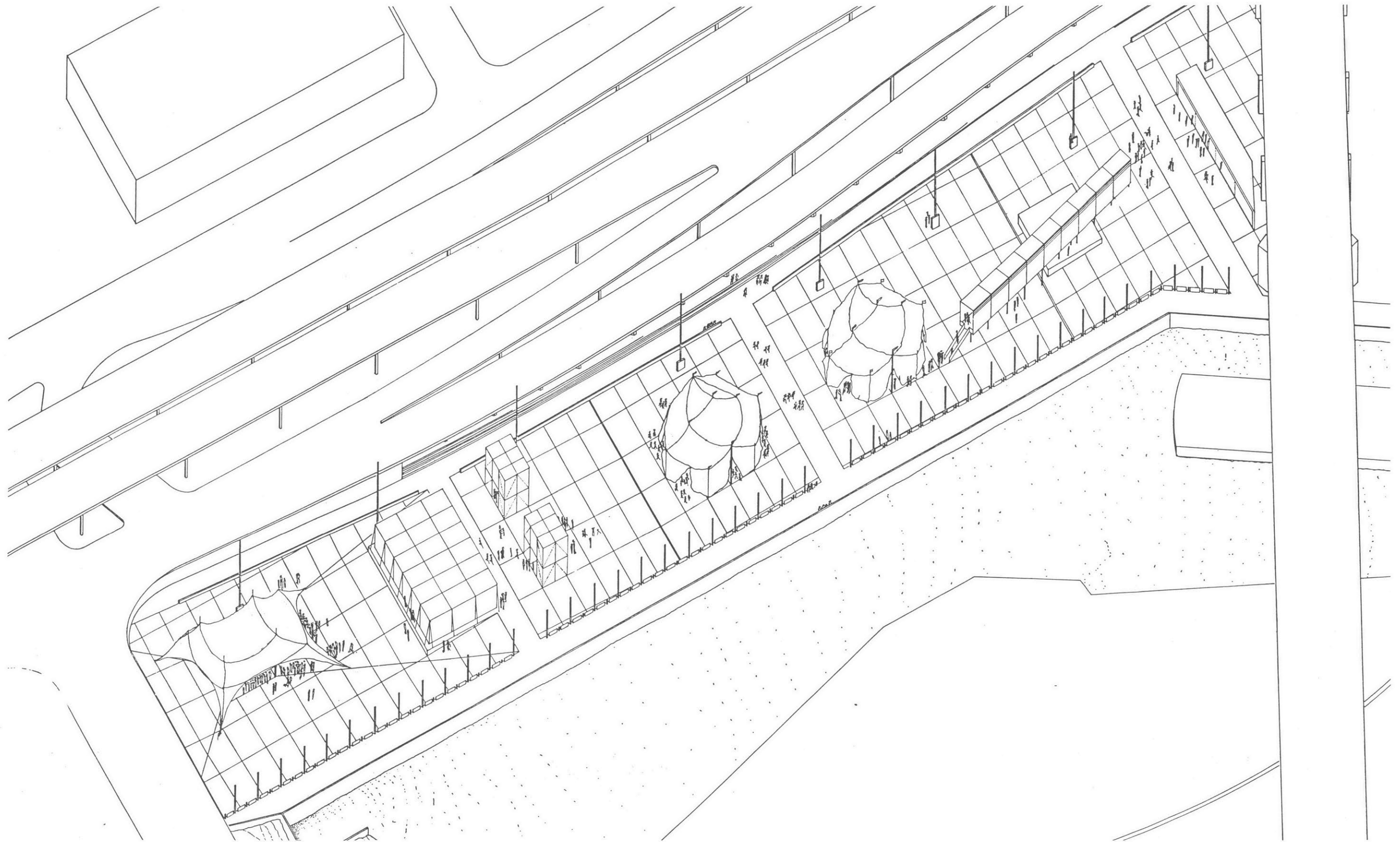

Fair

At the fair, the variety of events requires more spatial orchestration as far as the deployment of each element. Because they range from a palm reader's booth to a large, main tent, the scale of inhabitation occurs at both the level of the swap meet and the concert. But the amount of equipment necessary for each venue (rides, fast food, games, displays, etc.) is greater so that the fair cannot be completely organized by the grid in terms of individual lots or a stage and seating.

Access to utilities can be gained almost anywhere, but the inherent spatial hierarchy of the fair gives the project a more textured form of inhabitation.

Sources

Benevolo, L. History of the City
Cambridge, MIT Press, 1988.
pages 19-24.

All others by author.

Beyer, Andreas. Andrea Palladio. Teatro
Olympico. Frankfurt, Fischer Verlag,
1987.
pages 50-51.

Klein's Maps. Boston City Map. Hyde
Park, MA. 1980.
page 9.

Process Architecture. "Boston by Design",
Tokyo, Process Architecture Publishing,
1991.
pages 7,8.

Quaderns #177. "New Narration",
Barcelona, Liberia Internacional, 1988.
pages 25, 26.

Rowe, Colin and Koetter, Fred. Collage
City. Cambridge, MIT Press, 1990.
page 23.

Trorey, Lyle G. Handbook of Aerial
Mapping and Photogrammetry. Cambridge
, University Press, 1950.
page 7.

Waldenburg, Hermann. The Berlin Wall
Book. London, Thames and Hudson,
1991.
page 25.