

**HYPERSensarium:**  
An Archive of Atmospheric Conditions

by Kelly E Shaw

Bachelor of Science in Product Design  
Stanford University, 2006

Submitted to the Department of Architecture in partial fulfillment of the requirements for the degree of Master of Architecture at the Massachusetts Institute of Technology.

February 2013

© 2013 Kelly Shaw. All rights reserved.

The author hereby grants to MIT permission to reproduce and to distribute publicly paper and electronic copies of this thesis document in whole or in part in any medium now known or hereafter created.

Signature of Author \_\_\_\_\_

Kelly Shaw  
Department of Architecture  
January 17, 2013

Certified by \_\_\_\_\_

J. Meejin Yoon  
Associate Professor of Architecture  
Thesis Supervisor

Accepted by \_\_\_\_\_

Takehiko Nagakura  
Associate Professor of Design and Computation  
Chair of the Department Committee on Graduate Students



## **THESIS COMMITTEE**

### **Advisor**

J. Meejin Yoon  
Associate Professor of Architecture  
Massachusetts Institute of Technology

### **Readers**

Caroline Jones  
Professor of the History of Art  
Massachusetts Institute of Technology

Joel Lamere  
Assistant Professor of Architecture  
Massachusetts Institute of Technology

Christoph Reinhart  
Associate Professor of Building Technology  
Massachusetts Institute of Technology



# **HYPERsensarium:**

An Archive of Atmospheric Conditions

by **Kelly Shaw**

Submitted to the Department of Architecture  
on January 17, 2013 in partial fulfillment of the  
requirements for the degree of Master of Architecture.

Thesis Supervisor: J. Meejin Yoon  
Title: Associate Professor of Architecture

## **ABSTRACT**

HYPERsensarium proposes a tangible interface of atmospheres for public experience through an archive of historical and projected weathers. While architecture's purpose has long been to act as the technical boundary between the body and nature's elements this thesis seeks to re-expose the body to conditions society has disengaged itself with both physically and socially.

Despite scientific data showing rising surface temperatures, increasing carbon dioxide levels, rising sea levels and extreme weather occurrences, environmental issues occur on scales of time and space too broad for human understanding. Air is invisible and thus uncontested.

HYPERsensarium is an experiential museum of weather chambers, de-neutralizing the weather for public immersion. Architecture becomes the medium through which the senses are isolated and then re-conditioned for the archived weathers. With the majority of the project submerged within the grounds of Washington, D.C., visual, acoustic and thermal conditions reach stasis before visitors emerge into one of the archive's chambers. The environments within the chambers are mechanically driven, juxtaposing the visitor's "natural" views with an artificial atmosphere absorbed through other sensoria.

The thesis seeks to rethink the archive as a physical and digital system collecting and accumulating data. Accumulated data no longer sits dormant within traditional archival typologies but can be used to recreate physical conditions with which to finally ground our relationship with our surrounding atmosphere.



## ACKNOWLEDGEMENTS

Architecture is impossible to do alone.

I would like to thank the faculty and my fellow classmates for giving me both the encouragement and challenges I needed to make the most of the last 3.5 years.

To Meejin for being a great mentor and advisor. You gave me the support I needed to see what my thesis could be and the occasional shove when I couldn't.

To Joel, your insights and suggestions always gave me clarity when I was most annoyed and confused. Working with you helped me approach my own thesis with a more critical eye.

To Caroline, your wealth of knowledge helped me to develop my premise and historical understanding of atmosphere, sensoria and the body.

To Christoph, thanks for supporting my ideas of projecting future weathers and for helping me to realize them through existing software and building systems.

To Jusin Gallagher, Nick Polansky, Moe Amaya, Yihun Lim, and Patrick Little. Thank you for all your help with rendering, models, diagrams and being good friends. You guys are rockstars for being so generous with your time on so little rest.

And most of all I want to thank my family. To Gi, Jane, Christine, Mom, Dad and Cathy, thank you for making it all possible.



## CONTENTS

### Proposal

Introduction	12-14
Discourse: Augmenting Atmosphere	15-20
Registering Atmospheric Change	21-26
Archiving Atmosphere	27-32
Site: Washington, D.C. Mall	33-38

### Strategy

Redesigning the Airlock	40-49
Weather Chambers	50-54
Attenuated Exhibition	55-66
Experiencing HYPERsensarium	67-70
Models	71-78

### Appendix

Precedents	81-91
Pecha Kucha	92-100
Thesis Defense	101-107

Bibliography	109-110
--------------	---------



## PROPOSAL

LEFT: Approaching HYPERsensarium  
from Madison Drive NW.

Earth's Atmospheric Composition

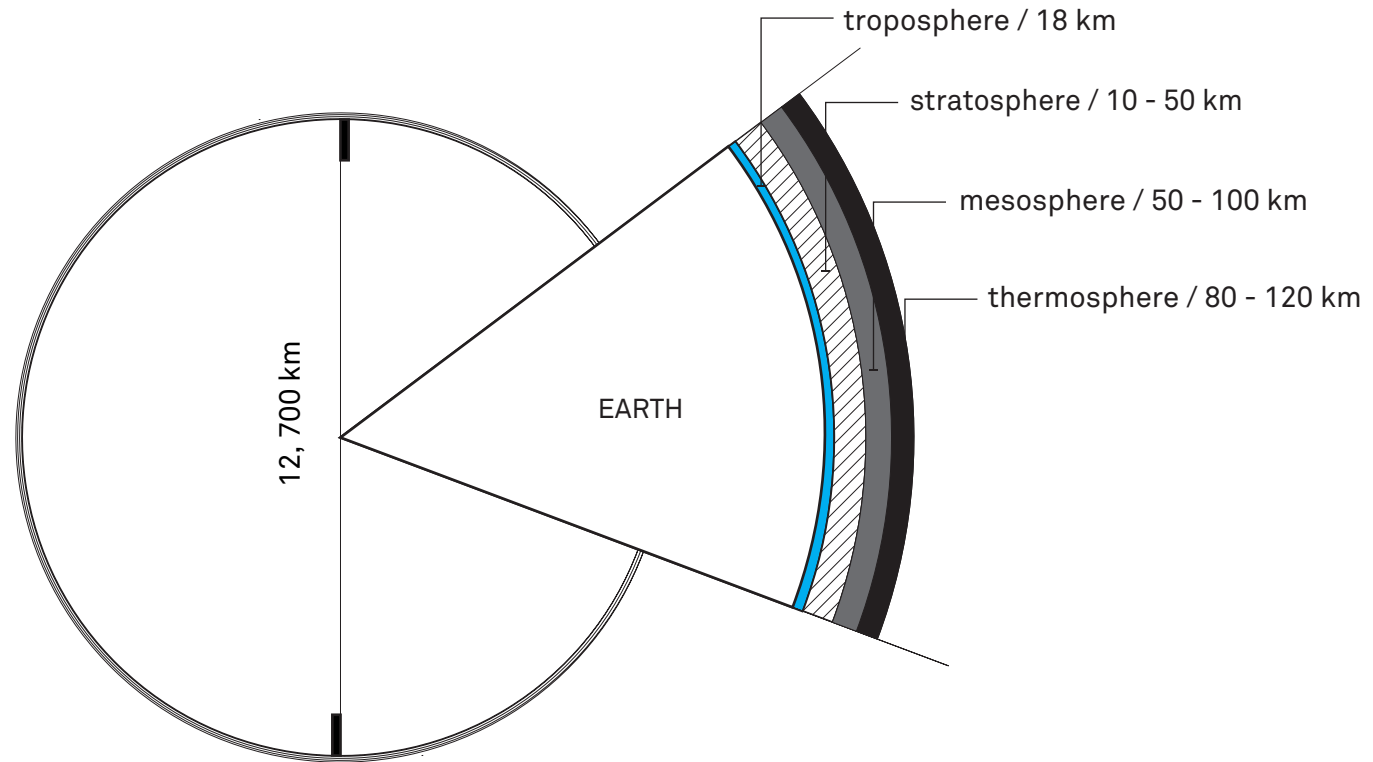

## TROPOSPHERE

**78%**  
nitrogen

**21%**  
oxygen

**0.9%**  
argon

**0.039%**  
carbon dioxide

**0.0002%**  
methane

“Hmmm...What #Frankenstorm-inspired beverage can I create with Three Olives Cherry vodka and Diet Mtn. Dew?”

-tweeted by renaerenae7134  
7:55 PM, December 15, 2012

## INTRODUCTION

Like many other #Frankenstorm-handled tweets, renaerenae7134's illustrates how quickly weather and extreme climatic events can manifest themselves into cultural psyche, evolving from the catastrophic event itself to Urban Dictionary status. The term "Frankenstorm" evokes an exquisite corpse of weather phenomena, suggesting that this "freak" weather event was somehow "created" by man. Just as Frankenstein was the fabled monster created by man's obsession with control over mortality, Hurricane Sandy's moniker alludes to society's own role in bringing about the storm. In the aftermath of the October hurricane, The Wall Street Journal reported that Sandy cost upwards of \$20 billion.<sup>1</sup> Concurrently there was an intense rush to use Hurricane Sandy for didactic purposes: to refocus public engagement on the buildup of greenhouse gases and their direct relationship to global warming.

Following extreme summers, intense droughts and events such as Hurricane Sandy, there are many who would believe that these events would push public opinion to act on climate change agendas. However, these events trigger more social and community-driven actions than any long-term momentum towards climate change. There is a disconnect in the way humans struggle to understand atmosphere and our place in it. When extreme weather events or particularly haze-filled days arise, we may acknowledge the suggested impact of our industrial activities and carbon footprint. Yet on the next clear day,

---

<sup>1</sup> Erik Holm and Leslie Scism, "Sandy's Insured-Loss Tab: Up to \$20 Billion," The Wall Street Journal, 16 December 2012, <<http://www.online.wsj.com>>.

the thought vaporizes into the atmosphere along with any sensorial impact we may have previously experienced. Humans have existed in this proverbial “bubble” of Earth’s atmosphere for so long that it is still controversial how much human activity can be blamed for such Frankenstorms, thereby creating no urgency for us to change centuries of behavior.

We live within a space of air which we can never quite hold onto or control and in that sense, it can be considered one of the few untamed natural resources left in our world. Paradoxically we have attempted for centuries to utilize and control the atmosphere and its conditions for both personal and collective gain. This thesis questions the ways in which we have historically struggled to understand, capture and condition ourselves from atmosphere through architectural means. It proposes an architecture that acts not as a protective barrier from nature, but as a platform where we can confront our relationship with atmosphere.

If the goal of architecture was once to meet humankind’s fundamental need for shelter, HYPERsensarium seeks to re-engage the public body with space, by removing barrier from architecture’s role and re-imagining it instead as mediator.

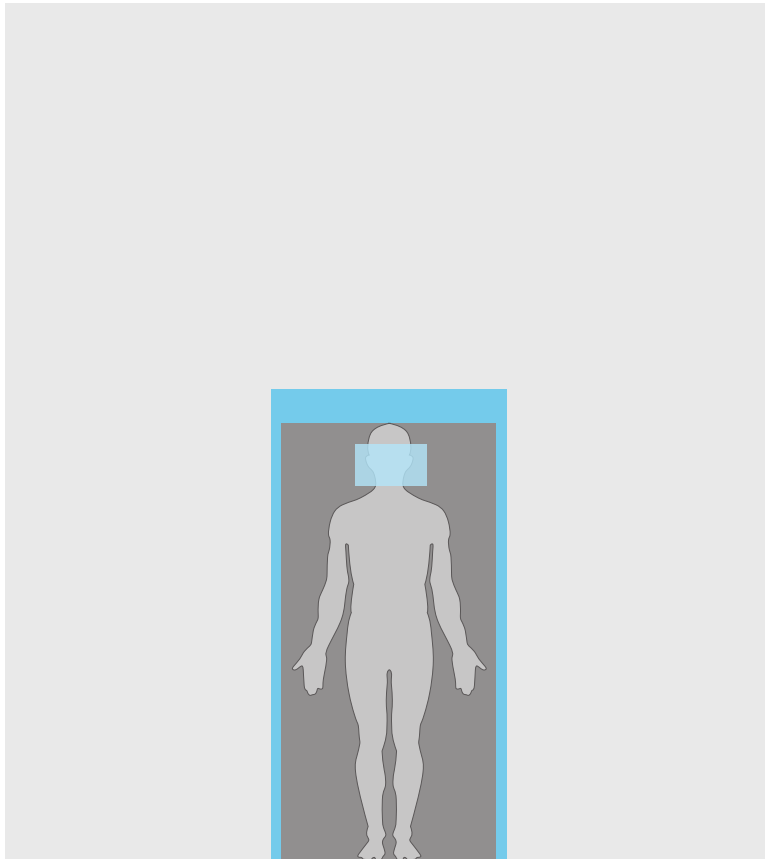

## DISCOURSE: AUGMENTING ATMOSPHERE

Our understanding of climate was shaped by science and technology while our relationship with it was shaped by the interface of architecture. While no one could see air, humans knew it was there and spent centuries trying to regulate its dimensions. Initially air's position as an "other" could only be understood through observations and their correlation with time of occurrence. Farmers first used cloud movement and sky color to forecast ideal times to sow and reap. Mariners relied on wind shift and wave motions as signs of change.<sup>2</sup> What occurred within the space of our atmosphere was poorly understood but it was clear that it had persistent impact on the way society conducted its day-to-day activities. With advancement in technology, the invisible air has been restricted with our own social and political delineations ranging from the control of rain and restricting industrial emissions, to regulating no-fly zones and the uploading of digital data to a virtual cloud.

Weather and air have long been perceived the nemesis of architecture, as its purpose was to place the physical boundary between the human body and the unpredictable natural elements. The moment that the building became the container for the body, and the body became a passive object in need of protection from nature, was the moment when society began to disengage itself from its atmosphere. Reyner Banham reminded us that archaeological evidence existed that mankind could exist almost anywhere but the coldest and driest places on earth, writing, "a naked man armed only with hands, teeth, legs and native cunning

<sup>2</sup> Tomas Bartzak, "Weather + Science," *arium: Weather + Architecture* (Ostfildern: Hatje Cantz Verlag: 2010), 47.

Augmenting the air around the human body.

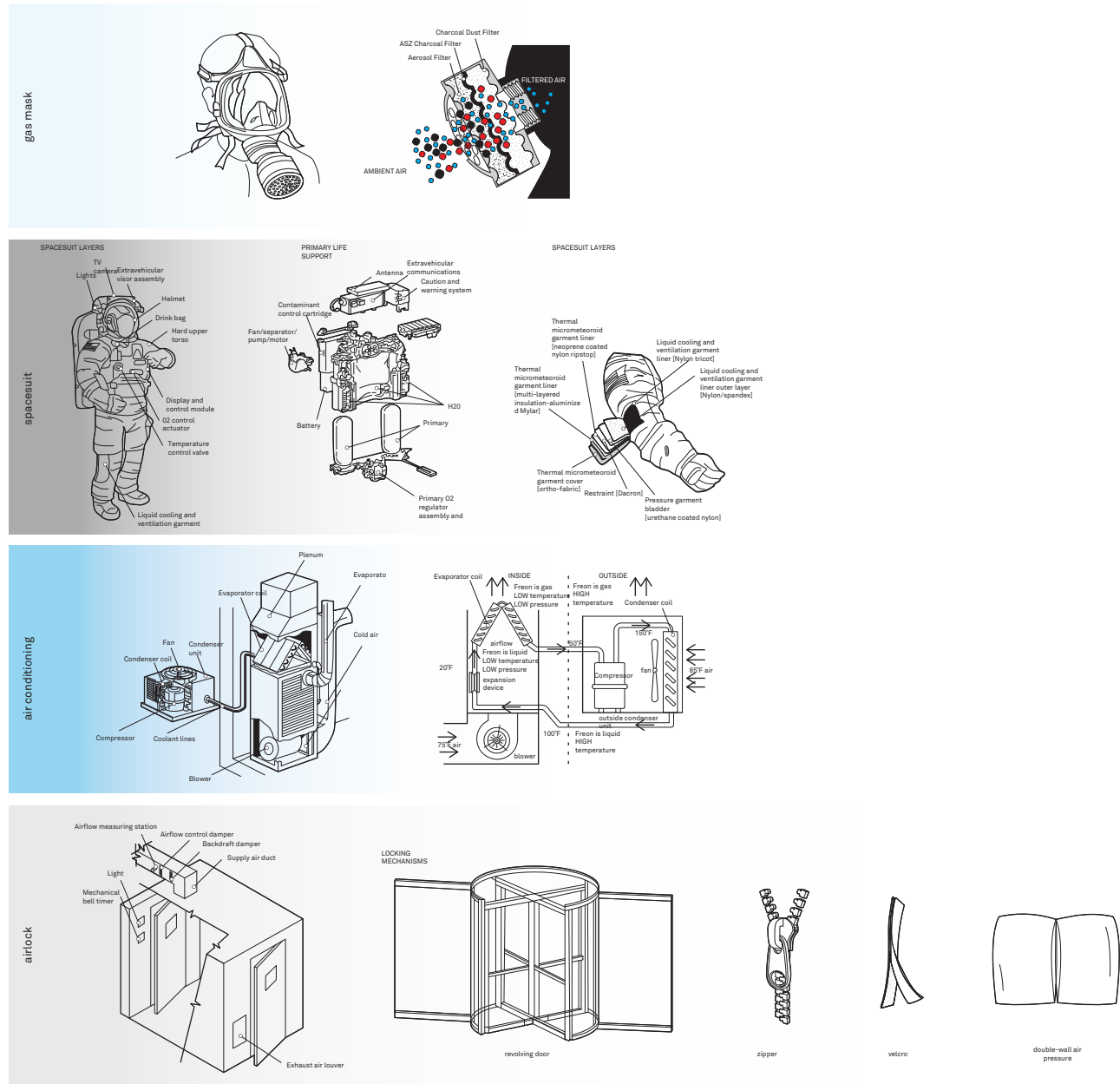

appears to be a viable organism everywhere on land, except in snowfields and deserts. But only just; in order to flourish...mankind needs more” and that more could be achieved through architectural considerations.<sup>3</sup>

Man could certainly survive almost anywhere but to progress our culture, we had to create a more pleasant atmosphere conducive to our bodies achieving optimal performance. Air had to be conditioned if we wanted conserve the energy used for staying warm or keeping cool by our own physiological reactions, i.e. the energy expended by our bodies through shivering and sweating. Architects would develop the permanent structures which could protect the body from nature, thus inscribing architecture as society’s defense against the elements. Vitruvius’ Book VI on Architecture stated climate as determining the style of the dwelling in its very first chapter.<sup>4</sup> The assertion that climate should be a design consideration and that architecture should shelter humans from extreme cold or heat, while letting in light, became one of the founding principles of “good” architecture.

During the Renaissance, it was the invention of tools such as the hydrometer, thermometer and barometer which would finally allow us to take measurements of our atmospheric conditions accurately. By the 19th century, the further invention of the balloon and telegraph enabled society to begin accurately predicting and forecasting weather conditions. It was discovered that the properties of the atmosphere -- temperature, moisture and air

3        Reyner Banham, The Architecture of the Well-tempered Environment (Chicago: University of Chicago Press, 1984), 18.

4        Marcus Vitruvius Pollio, trans. by Morris Hicky Morgan, “Book VI,” Ten Books on Architecture, Digireads.com, (1 Jan. 2005).

pressure -- could be utilized to both categorize and forecast weather conditions. While we were seemingly still unable to influence the weather, we could use technology to help prepare for unwelcome conditions.

Ironically, just as we had established that the architectural barrier could protect us from the air outside, we became troubled by interior air. Air was in fact everywhere. You could subdivide it a million times and there would still be air around you. It was both necessary for life to exist, yet the Industrial Revolution introduced the human capacity to create harmful air. At the beginning of the 19th century, fear of the exterior shifted into concerns about toxic interiors as urbanization and industrialization took hold. “Increased overcrowding in urban areas, coupled with the knowledge gleaned from developing the science of air chemistry, led to a widely accepted theory regarding the human contamination of air. Body odour was presumed to result from ‘putrefaction’, or rotting skin, and the carbon dioxide exhaled in each breath was considered to be highly poisonous.”<sup>5</sup> Openings were added both to rooftops and facades to facilitate cross-ventilation and light. Unfortunately epidemics in the early 20th century would re-seal the buildings just as quickly as they had been opened amidst public health concerns. Fortuitously, the newly born heating, ventilation and air conditioning (HVAC) industry was quick to capitalize, offering manufactured environments that were ‘cleaner and purer than what nature could provide’.<sup>6</sup>

5        Michelle Addington, “Contingent Behaviours,” Architectural Design: Energies New Boundaries 79.3 (May/June 2009), 14.

6        Carrier Engineering Corporation, “The Story of Manufactured Weather,” Carrier Engineering Corporation (New York, 1919), 5.

It was at this moment when environmental technologies were developed during the late 19th and early 20th centuries that human comfort became perceived as something to be constructed and architecture went from being the “container” for the body to the “barrier”. However, with the development of HVAC systems, technology could now augment the body’s needs, thereby further liberating architecture’s role as the mediator between climate and body.

In essence all of Vitruvius’ tenants on climate’s role in shaping architecture could now be addressed with technology, keeping the space around us at a comfortable 18 degrees Celsius, freeing the architect to design with Modernism’s new steel and glass technologies. Such changes to envelope and construction were only possible once site and climate could be completely decoupled from architectural consideration. While architects such as Le Corbusier and Mies Van Der Rohe would capitalize on these changes to explore new materials and form, glass for all its pure and modernist intentions was still implemented to visually dissolve the barriers between interior and exterior. Thus, the visual and a view out towards nature were still central to the successful perception of space.

Society needed to have its views onto nature without necessarily having to deal with its uncomfortable effects. In 1914, engineer Paul Scheerbart declared that glass could dissolve the barriers of experience between inside and outside. “We mostly inhabit closed spaces. These form the milieu from which our culture develops...If we wish to raise our culture to a higher plane, so must we willy-nilly change our architecture. And this will be possible only when we remove the sense of enclosure from

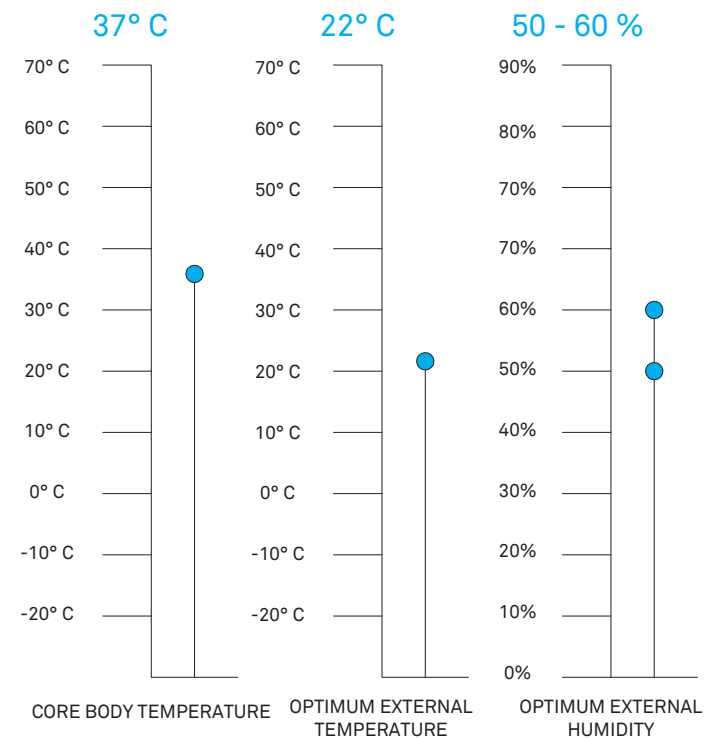

Human Energy Balance Optimums

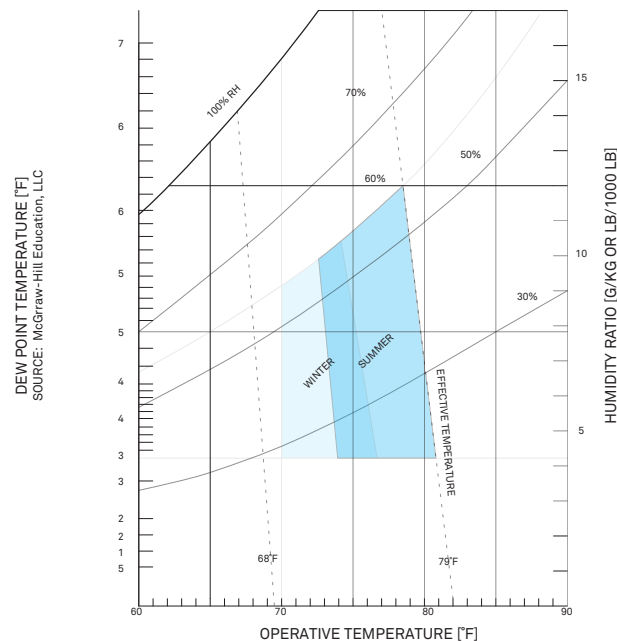
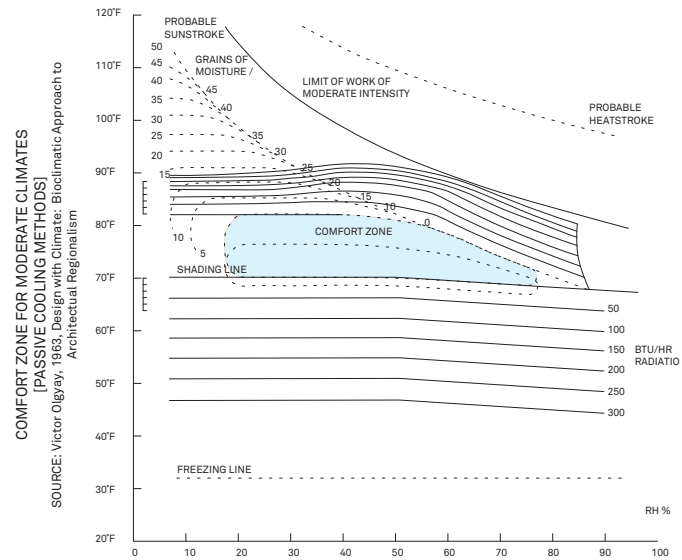

the space where we live.”<sup>7</sup> With the implementation of new building materials such as glass, the body was now fully separated from the environment both physically and conceptually. The envelope of the building could become the site for formal and visual expression, showing inhabitants the exterior views of nature and letting in light. Meanwhile, environmental technologies created the perfect temperature for the body regardless of what nature was brewing outside.

The body’s physical disengagement from the air outside was further sealed when organizations such as the American Society of Heating, Refrigerating and Air-Conditioning Engineers (ASHRAE) developed the prevailing definition of thermal comfort as ‘those conditions in which 80% of the occupants do not express discomfort’.<sup>8</sup> The goal of the interior environment would now become uniformly distributed and one could share identical interior conditions worldwide, whether in a New York office building or one in Dubai. Furthermore, the techne behind the homogeneous, ideal environments could be delivered through hidden vents, pipes, ducts and storage units, rendering their expression and delivery invisible to the human eye and in turn, our consciousness. The conditioned natures within the interior were now as seamless as those of the exterior. Architecture as a system of envelope, structure and HVAC has succeeded in shaping our construction of space to that of a hermetic, conditioned environment. It is no surprise that we are unable to imagine air as anything tangible beyond the built environment. It was also Banham who would say that those

<sup>7</sup> Banham, op.cit., 126.

<sup>8</sup> ASHRAE, “Thermal Environmental Conditions for Human Occupancy,” American Society of Heating, Refrigerating, and Air Conditioning Engineers (ASHRAE) Standard 55-2010.

“cultures whose members organize their environment by means of massive structures tend to visualize space as they have lived in it, that is bounded and contained, limited by walls, floors and ceilings.”<sup>9</sup>

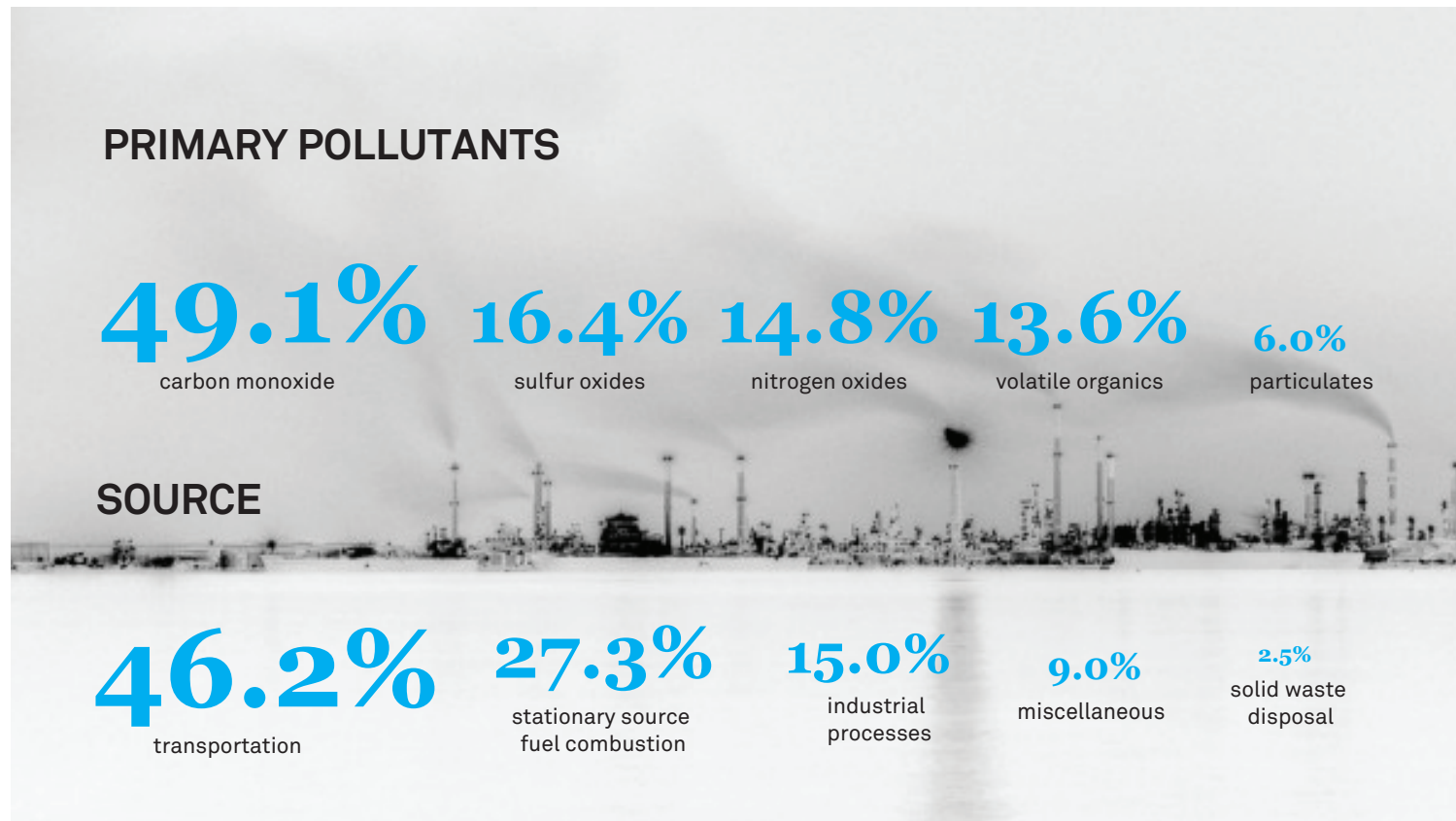

SOURCE: U.S. EPA Statistics.

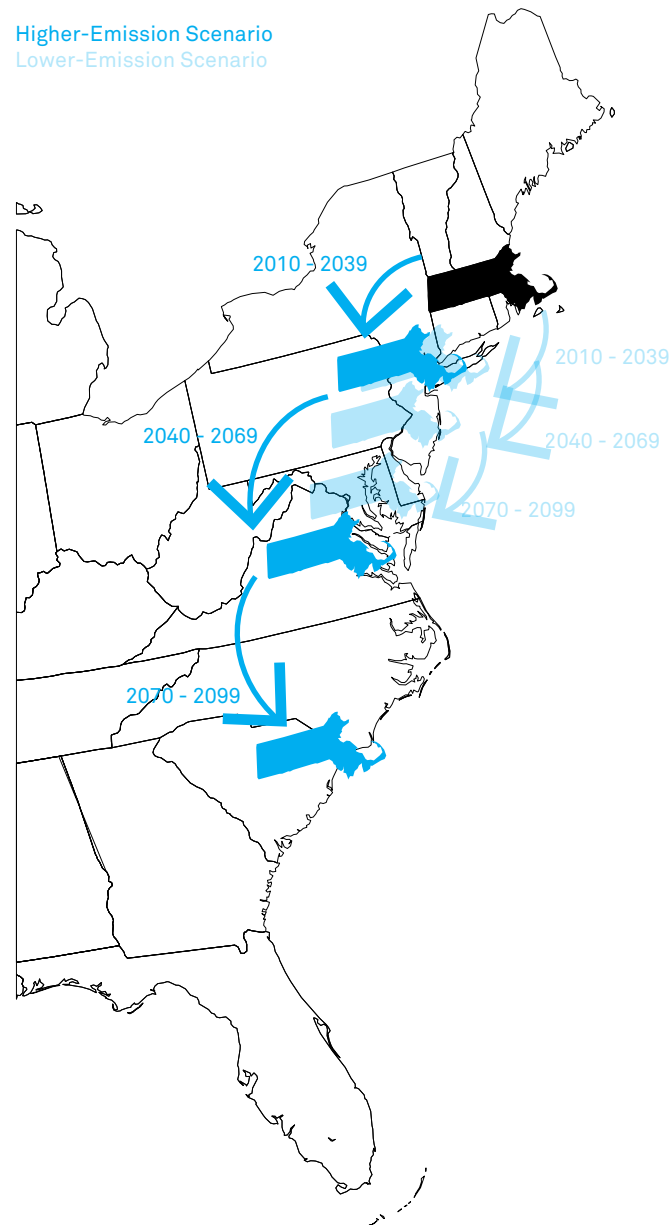

## REGISTERING ATMOSPHERIC CHANGE

Despite the technology in place with which to predict weather, our social and political systems for coping with change, and our ability to create conditioned environments seamlessly integrated into our daily lives, we remain unable to control how the air and its conditions move through our atmosphere. While we are able to directly affect it through industrial emissions, the consequences occur on scales of time too large for society to digest. The now common appearance of smoke, haze, acid rain and acid fog warnings in daily forecasts reflect the human effect on the make-up of our atmospheric conditions. Rather than acting as a static, invisible environmental envelope, air circulates and is responsive to our actions.

The five primary pollutants in the air today are carbon monoxide, sulfur oxides, nitrogen oxides, and volatile organics and particulates. The majority of these pollutants are gases created from industrial activities such as fossil fuel combustions, oil refining or metal smelting. Almost 50% of primary pollutants come in the form of carbon monoxide, the largest source coming from motor exhaust.<sup>10</sup> Data from NASA recording global land-ocean temperatures show that global surface temperatures in the last 10 years have been the highest on record in over the last 120 years.<sup>11</sup> Recent climate assessment reports predict that in less than 100 years, a typical summer in Massachusetts may feel more like a present-day summer in South Carolina.<sup>12</sup> Furthermore, in the last 650,000 years, atmospheric

<sup>10</sup> U.S. EPA Statistics.

<sup>11</sup> NASA GISS Surface Temperature Analysis.

<sup>12</sup> Union of Concerned Scientists, a report of the Northeast Climate Impacts Assessment (NECIA, 2007).

carbon dioxide levels have never been above 310 ppm, yet as of March 2012, Mauna Loa's NOAA Observatory recorded atmospheric carbon dioxide levels to be at almost 395 ppm.<sup>13</sup> Scientific data continues to suggest that our atmospheres are changing due to human activities as carbon dioxide levels can be linked to rising surface temperatures, rising ocean levels and changes in global weather patterns. Yet despite the accumulation of data and evidence pointing to human impact, society remains collectively ambivalent towards the air around us. In his introduction to *Greening through IT*, Bill Tomlinson writes, "The key problem in the way humans understand and act on environmental issues is one of scale. Environmental issues tend to occur on broad scales of time, space and complexity compared to the typical scope of human concerns."<sup>14</sup>

The impact of our choices on issues such as climate change are rarely immediately apparent, but instead unfold over long periods of time in typically distant or indirect ways. With so many immediate and more local concerns to attend to we continue to observe our atmosphere through our comfortably conditioned glass windows or television sets.

Global Land-Ocean Temperature Index (°C)

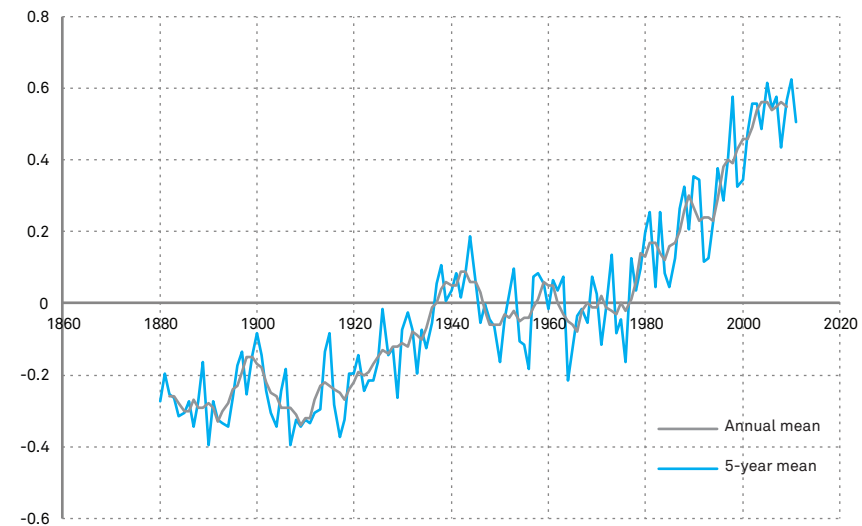

SOURCE: NASA GISS Surface Temperature Analysis

13 NOAA Mauna Loa, Hawaii Observatory.

14 Bill Tomlinson, "Introduction to Green IT," *Greening through IT* (Cambridge: MIT Press, 2010), 5.

Global Mean Sea Level Change (mm per year)

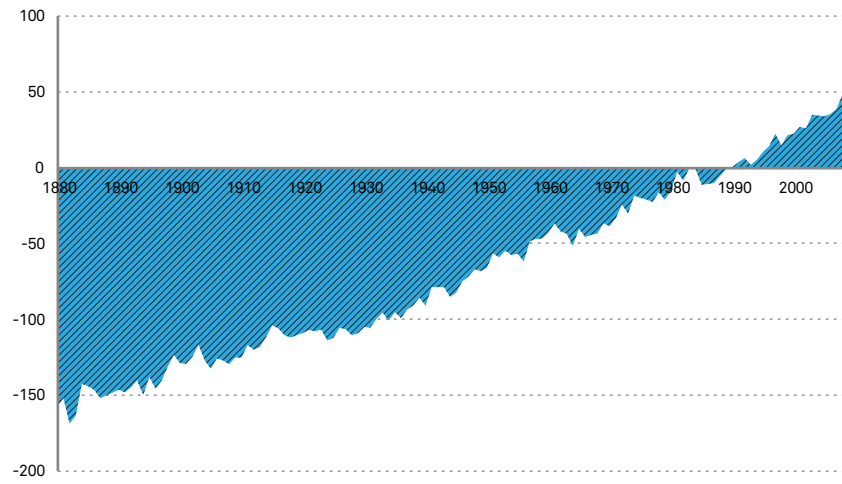

SOURCE: CSIRO Sea Level Data

Historical CO2 Levels (ppm)

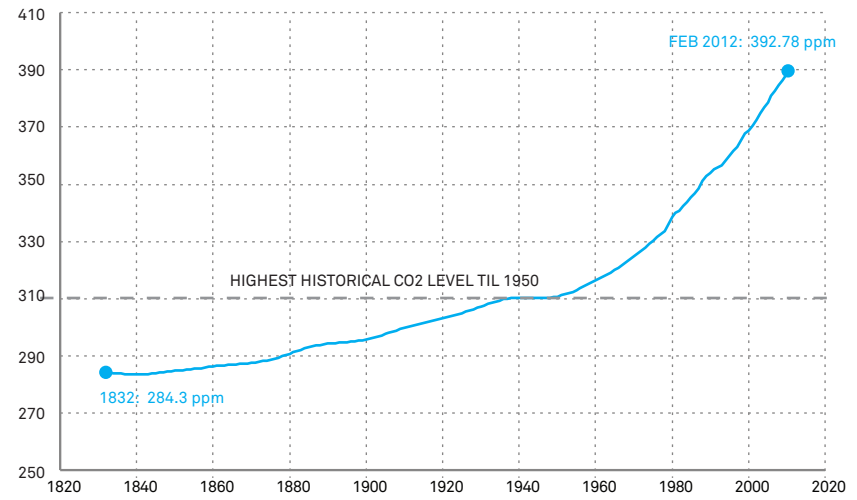

SOURCE: CDIAC Ice Cores Database + NOAA ESRL Data

Our relationship with air, despite its intangibility from our physical and mental world can be made visible quickly. Humans need air for survival, just as our bodies need to maintain temperatures around 98.6 degrees Fahrenheit. In Terror from the Air, German philosopher Peter Sloterdijk reflected on the gassing of French soldiers on April 22, 1915 by German troops as the moment when air and its ability to both give and remove life was made explicit. “Air has entered the list of what could be withdrawn from us.”<sup>15</sup> The medium through which we experienced light, taste, and sound was most precious when it was taken away.

15 Bruno Latour, “Air,” Sensorium (Cambridge: MIT Press, 2006), 105.

In a less immediately violent way there have been numerous other moments historically and even within the last ten years in which human activities have greatly altered the immediate experience of our exterior environment. Since the Industrial Revolution, mineral extraction firms, factories, energy companies and transportation modes have completely altered the composition of the air we breathe by aerosolizing elements once left within the Earth.

The city of Pittsburgh, Pennsylvania illustrates how the city, however successful steel manufacturing made it, still reels from a legacy of environmental pollution across the landscape by achieving the title of the number one city



Donora Zinc Works of American Steel & Wire Co., October 1948  
SOURCE: Archived photo, Pittsburgh Post-Gazette

most polluted by short-term particle pollution in the United States.<sup>16</sup> Short term exposures to particles can aggravate lung disease, causing asthma attacks and acute bronchitis. Across the U.S., Grand Canyon National Park has hired its own air quality expert as air pollutants traveling from as far away as Los Angeles and Las Vegas have obscured views and on some days, tinted the normally red walls of the canyon a bluish gray tint. In other parts of the world, industrial activities have caused some agencies to have to issue blue fog warnings as was the case in China on December 4, 2011 when the National Meteorological Center

of CMA issued smog warnings. From the night of the 4th to the morning of the 5th, visibility in Beijing, Tianjin and other cities were in extreme cases under ten meters, with air particulate matter concentration levels reaching 0.437 mg/sqm, temporarily reaching severe pollution levels. In such moments, air, once thought to invisible is made visible through its microscopic, human-produced agents.

16 American Lung Association's State of the Air Report (2008).



The best and worst visibility during a 24-hour period at the Grand Canyon  
SOURCE: NPS Image



Tonghu Road in Tongzhou district  
SOURCE: NetEase image

Atmosphere can thus be categorized in the sense that humans have constructed the conception of a “good” and “bad” air. In the bad, we have intense heat, extreme cold, poor visibility, extreme wetness, extreme dryness and even difficulty breathing. In our idealized version we have the conditioned environments of the interiors, which have become culturally metaphorized as a clear, Paris Spring day. All of these conditions are a historical and social reflection of our activities. Current climatic changes necessitate the ability to preserve, study and experience these atmospheres through an architectural space that can engage the public sensorially, giving memory and immediacy to their experiences. If the issue with public engagement and understanding of our atmosphere has been cut off through technology and architectural constructs, then both have the potential to re-engage. Our understanding of reality is a question of interfaces and re-imaging architecture as that interface. In his lecture “Over and Beyond and Limits of Reality,” artist and theorist Peter Weibel said, “The world changes in relation to our interfaces with it. The limits of the world are the limits of our interface. We do not interact with the reality of the world, we do so with its interface.”<sup>17</sup>

If architecture is in fact the boundary between our bodies and our understanding of the environment than we can also consider it as the moment of interface where information can be transformed into experience.

---

<sup>17</sup> Peter Weibel, “Over and Beyond the Limits of Reality,” Lecture held at the Arts Electronica 92 Symposium, Linz, Austria.

## ARCHIVING ATMOSPHERE

It was architecture which first negotiated our relationship with the weather, thus defining our current physical and mental separation from air. As the most fundamental and tangible creation of our physically constructed space, it also has the ability to become the platform with which we engage with the exterior. This platform for engagement is through HYPERsensarium, an archive for creating a program and tangible exhibition for experiencing historical and future projected atmospheres.

Nowhere is the presentation and curation of information more formally absorbed by the public than through the interface of the museum or archive. The archive in itself symbolizes and preempts what is important for a society's cultural posterity. If human activities have begun to register themselves on our environment, then their traces can be recorded and confronted through the museum. The archive is a program which prepares space for the eventual disappearance of its contents. In The Big Archive, Sven Spieker writes, "Archives do not record experiences so much as its absence; they mark the point where an experience is missing from its proper place, and what is returned to us in an archive may well be something we never possessed in the first place."<sup>18</sup> The archive can act as the link between the public and perceptions of cultural preservation, physical vulnerability and the human sensorium.

Utilizing both existing historical data collections and real-time inputs, HYPERsensarium acts as a vessel (Weather Chambers) for both historical and future climate conditions.

---

18 Sven Spieker, The Big Archive (Cambridge: MIT Press, 2008), 5.

Climate data fluctuates and changes rapidly as new inputs are taken in from observatories worldwide nearly every second of each day. While the presentation of these streams of data may mean nothing in the form of graphs and charts, the climate data stored in the archives contain temperature, relative humidity, air content, visibility; in essence, all of the bits and bytes of data making up the invisible atmosphere at a particular moment and place in time. Through the HVAC and lighting technologies invented to create the ideal hermetically-sealed conditions we experience today, such machines can be used to re-create the atmospheres we once believed to be fleeting.

Alternatively, historical climate data can be manipulated to project and predict future climate change, as is already utilized by the scientists who compile data for policy makers. Programs such as CCWeatherGen, allow users to generate climate change weather files ready for use in building performance simulation programs. The United Nations Intergovernmental Panel on Climate Change (IPCC) has published its Fourth Assessment Report (AR4) intended to assess scientific, technical and socio-economic information concerning climate change. Since it is difficult to project future emissions and the influence human factors will have on the climate, scientists have created a range of scenarios using various assumptions about future economic, social, technological and environmental conditions. Each scenario describes a different future based on factors such as population growth, economic growth and energy usage, resulting in varying rises in global surface temperatures and carbon dioxide levels.

Imagine a public who is suddenly able to understand how their energy use can impact their atmosphere by allowing

them to feel the sensation of entering a chamber ten degrees warmer than their current summer day. If the human ability to comprehend climate change is limited by the expanse of time and space, then information technology and the machines of climatization can be used to compress both time and space for public experience.

In experiencing such archived weathers or even forecasted weathers of the future in a decontextualized way, an archive of atmospheric conditions is not dissimilar to any other disassociation with seeing a work of art within a gallery. But most archives and museums of natural history choose to represent nature's single story and conserve only the most perfect specimens of nature; they confront the politics of representation.<sup>19</sup>

[HYPERsensarium proposes the creation of simulated, and in some cases, slightly uncomfortable atmospheres within the museum's own environmental conditions.](#)

In most museums, the temperature is set consistently at a chilly 65 degrees Fahrenheit, and a relative humidity at about 45 percent. As a critique of the sealed system of the museum, Hans Haacke created his own "real-time" system through the Condensation Cube (1963-65). The cube is a tightly sealed 30 by 30 centimeters holding about one centimeter of water. There is nothing in the cube but condensation dripping down its facades due to the basic properties of air, humidity and their reaction to the museum's own environmental system. In an essay on Hans Haacke's Condensation Cube, Mark

---

<sup>19</sup> Donna J. Haraway, "Teddy Bear Patriarchy: Taxidermy in the Garden of Eden," *Social Text* 11 (1984/85), 30.

HYPERsensarium's approach to archiving.

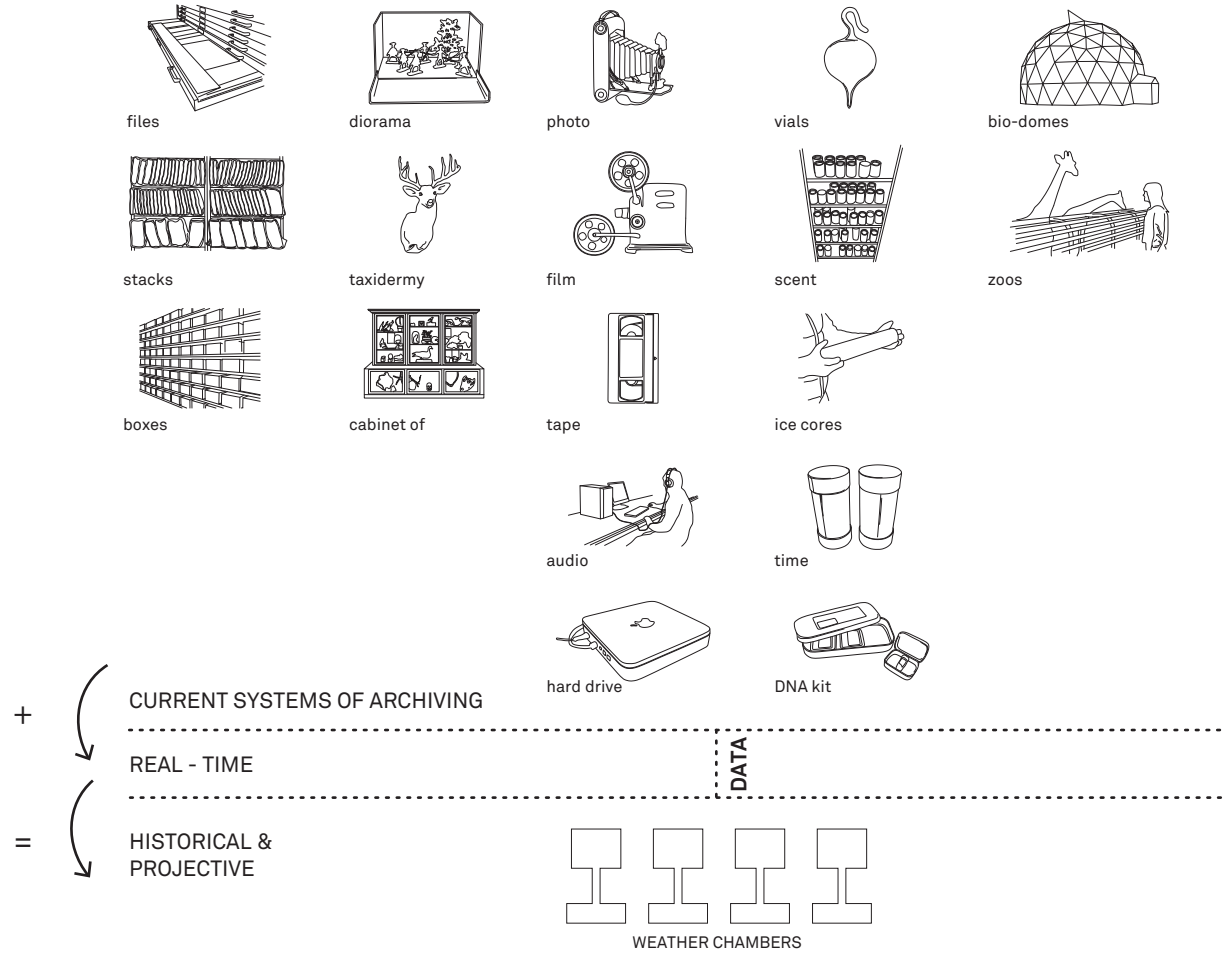

	● PROJECTED [A1, A2, B1,	● HISTORICAL ATMOSPHERIC CONDITIONS
	ECONOMIC FOCUS	PITTSBURG 1940S LONDON FOG 1948 DONORA SMOG PERFECT PARIS SPRING ETC.
GLOBALIZATION	A1 rapid	B1 global
REGIONALIZATION	A2 regionally	B2 local environ-

Jarzombek writes that Haacke's Cube "sets in play a rather complex game of illusions between the museum and the architecture that defines its space. This revolves not only around the word 'cube,' but also around the status of condensation as a cultural construct."<sup>20</sup> The Cube was in effect displaying the condensation happening within the insulation and waterproofing membranes hidden within the museum's walls. Haacke wrote about the aim of the system, which was '...to create something which gives in to the environment, which reacts, changes, is unstable...to create something that responds to light and to changes of temperature, is sensitive to air currents, with a functioning that depends on the forces of gravity...to create something that the 'spectator' can manipulate, can bring to life through his actions...to articulate something Natural...'<sup>21</sup>

The literal inversion taking place within HYPERsensarium is the inversion of exterior to interior. The museum's mechanical systems are now used for the production of these artificial weathers and the contents of its archive. Whereas once HVAC was used to preserve the idealized museological environment, the preservation of these forecasted and historical exteriors have been interiorized for public recognition of our reliance on architecture as the environmental mediator.

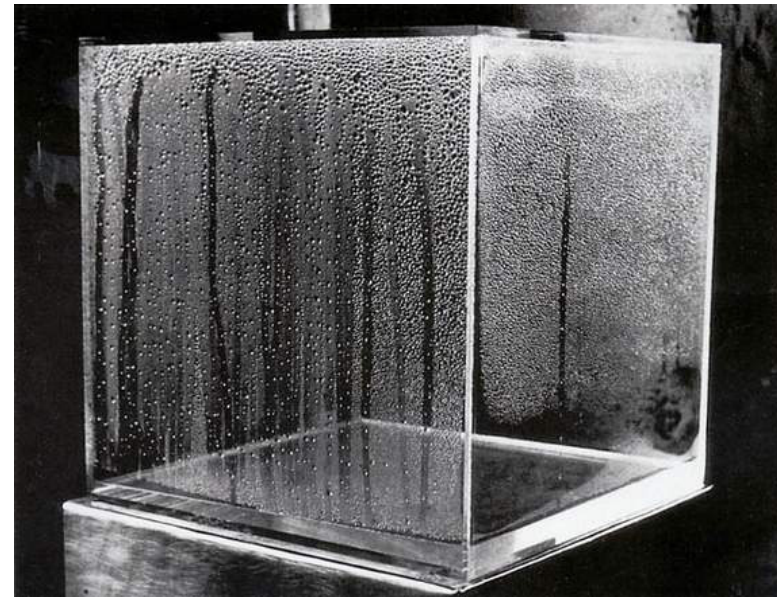

Hans Haacke, Condensation Cube, 1963-65  
SOURCE: C4Gallery.com

<sup>20</sup> Mark Jarzombek, "Haacke's Condensation Cube: The Machine in the Box and the Travails of Architecture," *Thresholds* 30 (MIT Department of Architecture, 2005), 99.

<sup>21</sup> Jaime Salazar, "MVRDV, VPRO," *Olafur Eliasson: Surrounded* (Graz, Austria: Neue Galerie, 2000), 529.



Olafur Eliasson, *The Weather Project*, Tate Modern, October 16, 2003-March 21, 2004  
SOURCE: [tate.org.uk](http://tate.org.uk)

Understanding our atmosphere, the air and its conditions cannot be done through a conventional museum exhibition where facts and figures are simply presented as printouts or video simulations. The understanding of the ethereality of “airs” we have experienced and potentially impacted must be done through precisely that medium. Like Haacke, artist Olafur Eliasson employs elements of environmental systems such as water, light, temperature and pressure to create immersive and temporal experiences for the viewer. Works such as *The Weather Project* (October 16, 2003-March 21, 2004) showcased at the Turbine Hall of the Tate Modern reveal human fascination with nature, even if it is an artificial one. Our fascination with the fog-filled, mist-spraying, sun-beaming sublime beauty of machines simulating nature is somehow unhindered by our awareness of the machines themselves. As part of the introduction to the project Susan May wrote, “The implication of transcendent experience at the core of the tradition is disrupted in his (Eliasson’s) work by the deliberate exposure of the apparatus delivering this phenomenal matter...By making us conscious of the construction so that we perceive the staging behind the representation, he also makes us conscious of the act of perception.”<sup>22</sup>

That we are aware of the constructed environment of HYPERSensarium makes it no less a reality that we are experiencing temperature, humidity or dampness on our skin. To really experience a winter that is ten degrees hotter in 100 years, as one of HYPERSensariums’ chambers might produce, the public must be able to engage with that ten degree increase within the conditions of their

<sup>22</sup> Susan May, “Meteorologica,” *Olafur Eliasson: The Weather Project*, (London: Tate Modern, 2003), 18.

current winter. In a sense, HYPERsensarium creates the instrument with which the visitor can isolate and refocus their senses. The existing atmospheric condition from which the public escapes from becomes the datum for all of the systems of HYPERsensarium about to be experienced. As that datum will itself be ephemeral, the experience of HYPERsensarium will be dynamic and different based on time, day and season. The contrast of HYPERsensariums' chambers with the present "real" exterior weather makes our relationship with climate and dependency on technology and architecture to act as the mediator explicit.

In HYPERsensarium, the museum acts to transcend our neutral attitude towards changing atmospheric conditions by bringing them back to Earth for our personal and collective sensorium.

Climate and environmental research and policy groups in Washington.

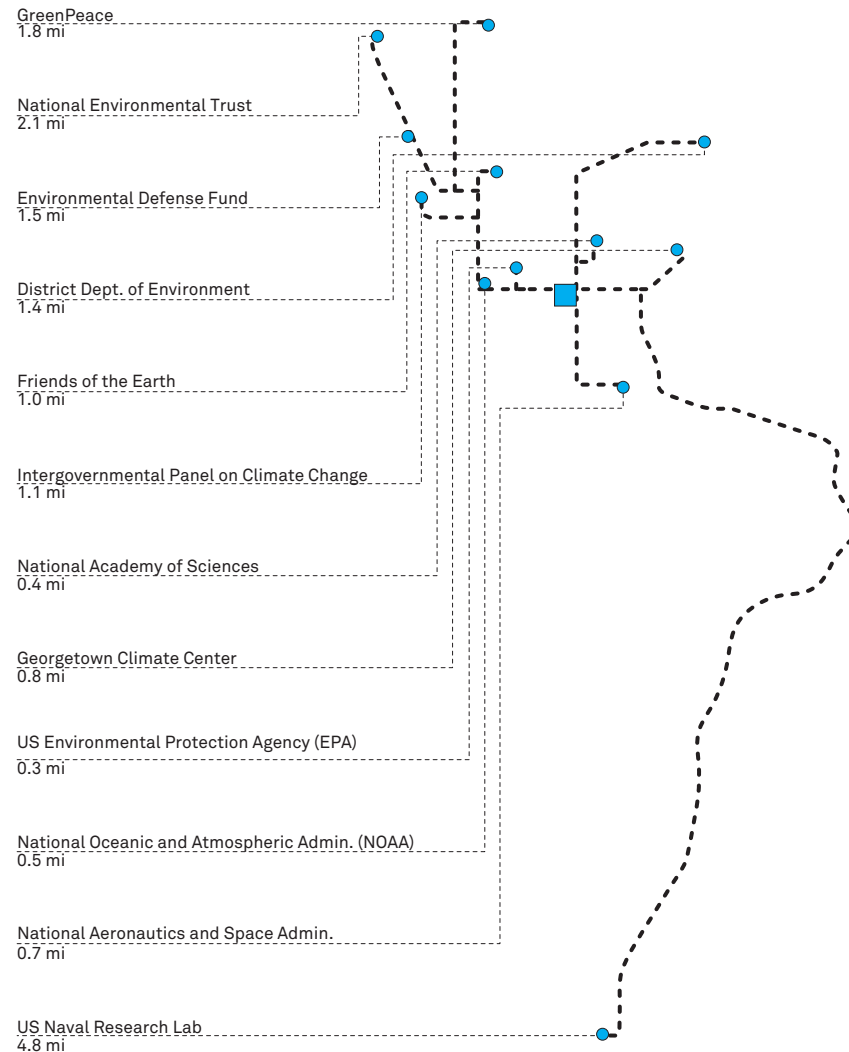

## SITE: WASHINGTON, D.C.

HYPERsensarium is sited on the western half of what is now the Hirshhorn Sculpture Garden in Washington, D.C. The Hirshhorn Sculpture Garden is one of a series of plots located along the National Mall, which is a monumental green space symbolic of the American national and cultural collective. Stretching nearly two miles from the U.S. Capitol building on the East to the Lincoln Memorial on the West, the Mall is a literal collection of museums, most of which belong to the Smithsonian Institute, the world's largest museum and research complex.

HYPERsensarium's landing between the Smithsonian's Air and Space Museum, National Museum of Natural History, National Archives and the Hirshhorn Museum shown in blue on the following site plan serves to strengthen the connections with the Mall's existing orthogonal plans. The Smithsonian Institute was established in 1846 with the mission statement to "The increase and diffusion of knowledge". In the last 100 years, the Smithsonian has amalgamated a large collection of free, publicly accessed museums on the Mall. These and other public institutions and monuments are shown in black.

The objects and artifacts found in these museums have been curated and presented by the museum as an institution, thus representing a consensus on not only what is deserving of cultural, historical or scientific preservation, but also how the public engages with what is being displayed.

In contrast to the site's existing collection of museums is HYPERsensarium's position as a new typology of interactive,

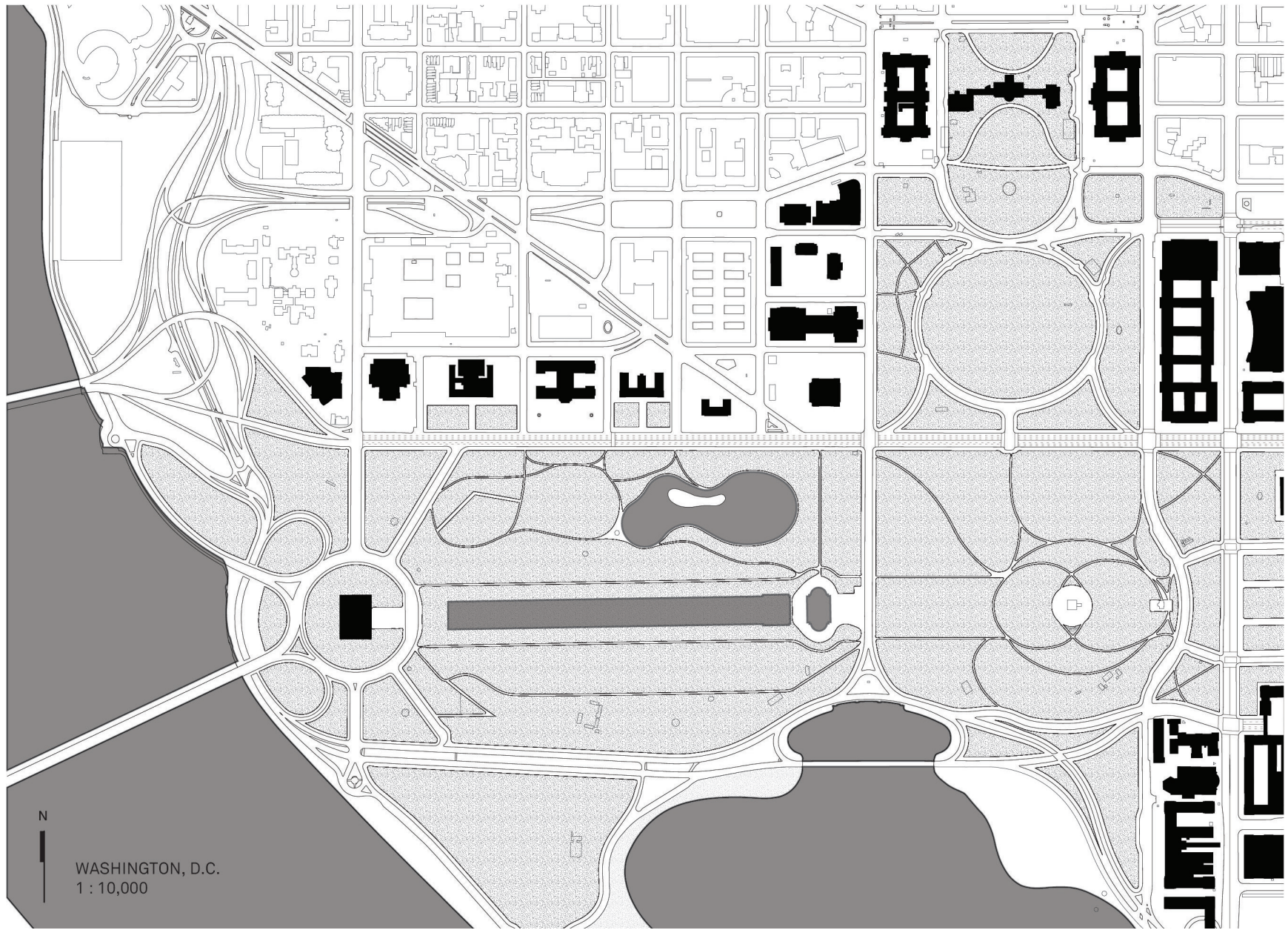

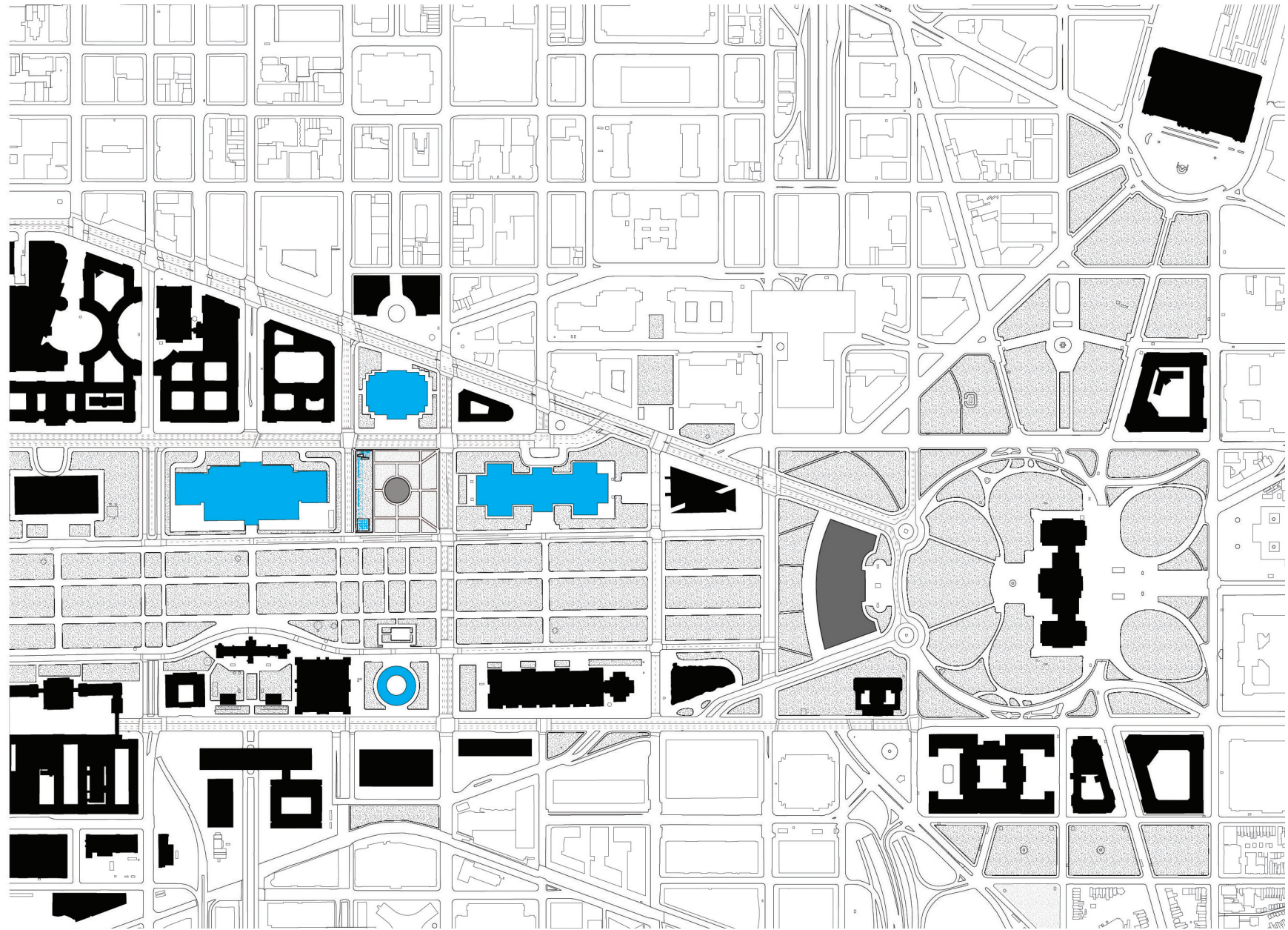

experiential space. The National Mall is a site pre-loaded with the production of the American national psyche by its proximity to other institutions charged with creating our nation's environmental policies. The Hirshhorn Sculpture Garden is within a five mile radius of at least a dozen other environmental policy and research organizations.

[HYPERsensarium's archived weathers and changing exhibitions are the result of the realization that our atmosphere is a dynamic condition warranting study and preservation.](#)

The Hirshhorn Sculpture Garden is a one-and-a-half acre recessed garden, currently displaying over 60 works of sculpture throughout the year. The center of the garden features a central reflecting pool which is converted into a public ice rink during winter months. HYPERsensarium's proposed strategy reveals only its four atmospheric chambers from the viewable garden level on Madison Drive. Entry into the museum is from an excavated entrance across the sculpture garden along Constitution Avenue.

[HYPERsensarium's visible chambers are minimized formally to act as distilled atmospheric moments within the garden, belying the more complex subterranean exhibition program beneath.](#)

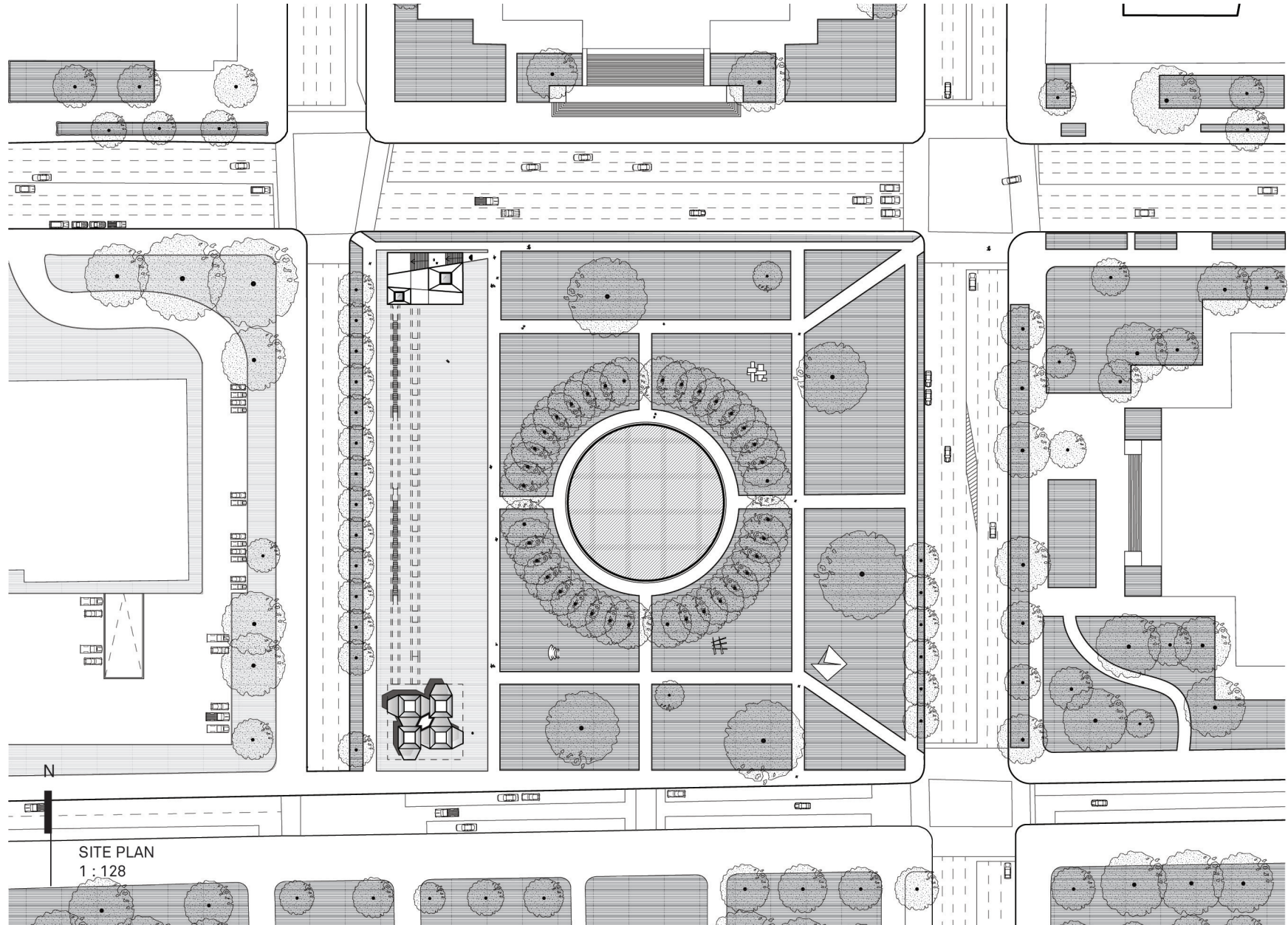



## STRATEGY

LEFT: Experiencing the sculpture park  
and HYPERsensarium at dusk.

Airlock Studies

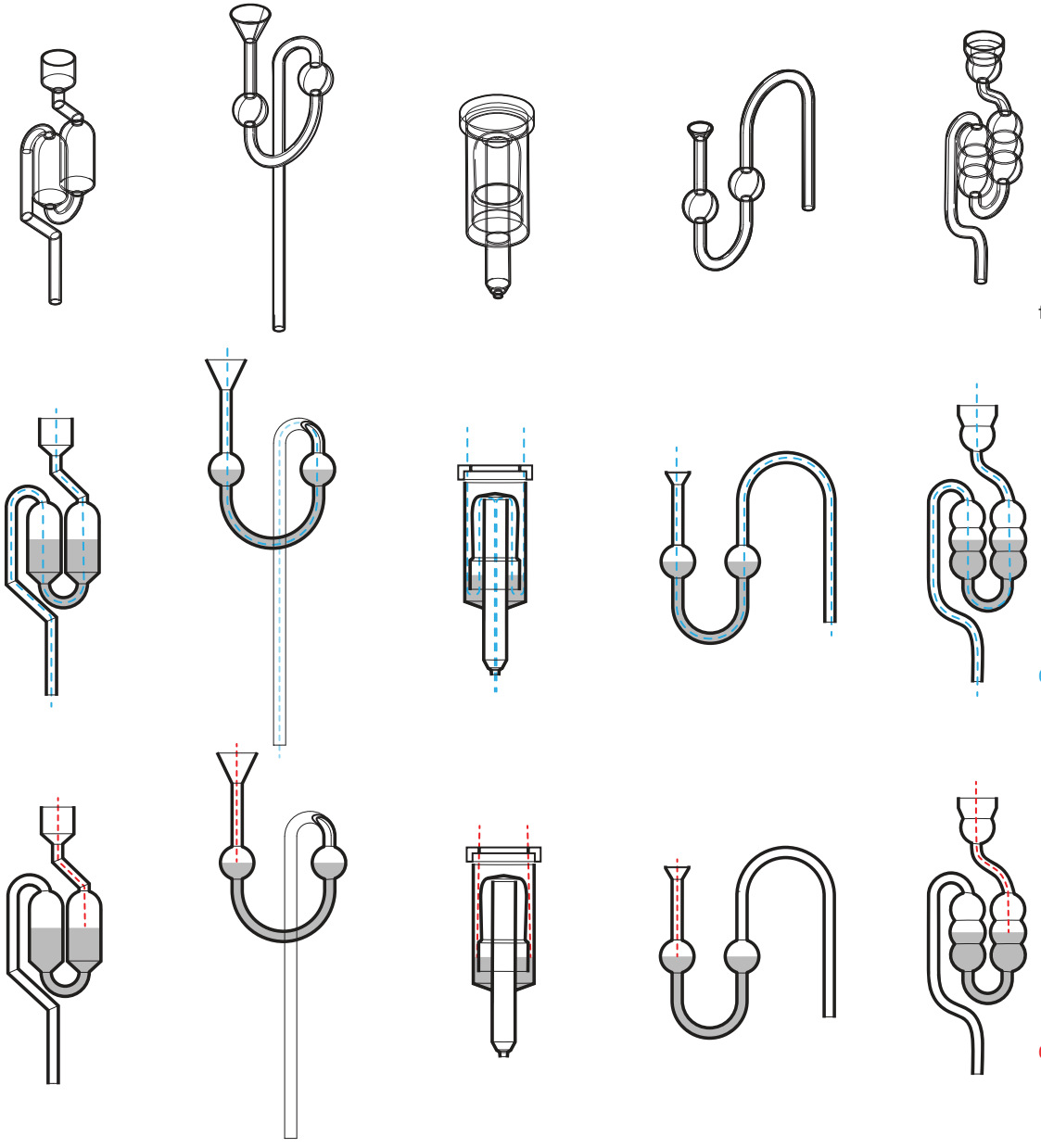

fermentation lock

CO2

O2

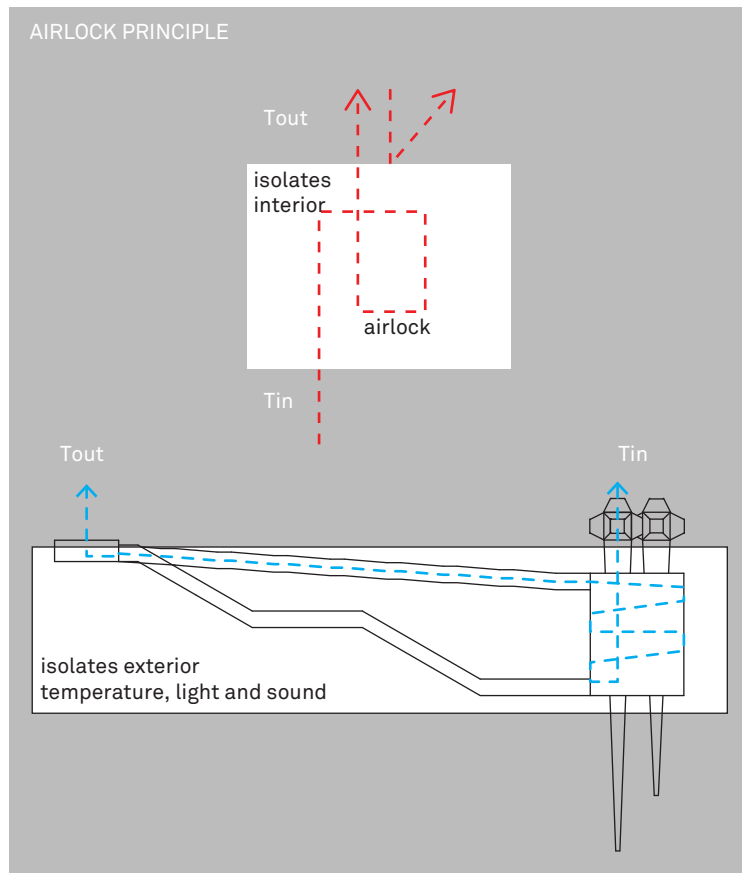

## REDESIGNING THE AIRLOCK

HYPERsensarium negotiates the movement of the public through a constantly changing outside environment, a constantly controlled museum interior and finally the exhibited atmospheres within each of the four weather chambers. Such a parameter necessitated the design of an architecture which could conceptually and physically support such an organization and sequence.

In examining various devices used for environmental control ranging from the gas mask to the ubiquitous revolving door, the fermentation lock became the parti for the thesis as it spatially produces a circulation route which can provide the attenuated exhibition experience to isolate, neutralize and then re-expose the senses to changes in air temperature and humidity.

The general principle behind the fermentation lock seen on the far left page is that it allows for carbon dioxide to be released through a “lock” made of water. The medium of the lock allows for carbon dioxide to escape due to the buildup of air pressure on one end of the lock without allowing oxygen to pass through from the other side. Restricting the movement of air to the release of carbon dioxide ensures that the environment on one end of the lock is free of exterior environmental contaminants.

In HYPERsensarium the museum itself acts as the lock. The public’s sense of light, temperature and sound are controlled by passage from the exterior D.C. climate into that of the underground museum. HYPERsensarium’s subterranean concrete architecture acts to acclimate the visitor to the museum’s hermetically sealed interior

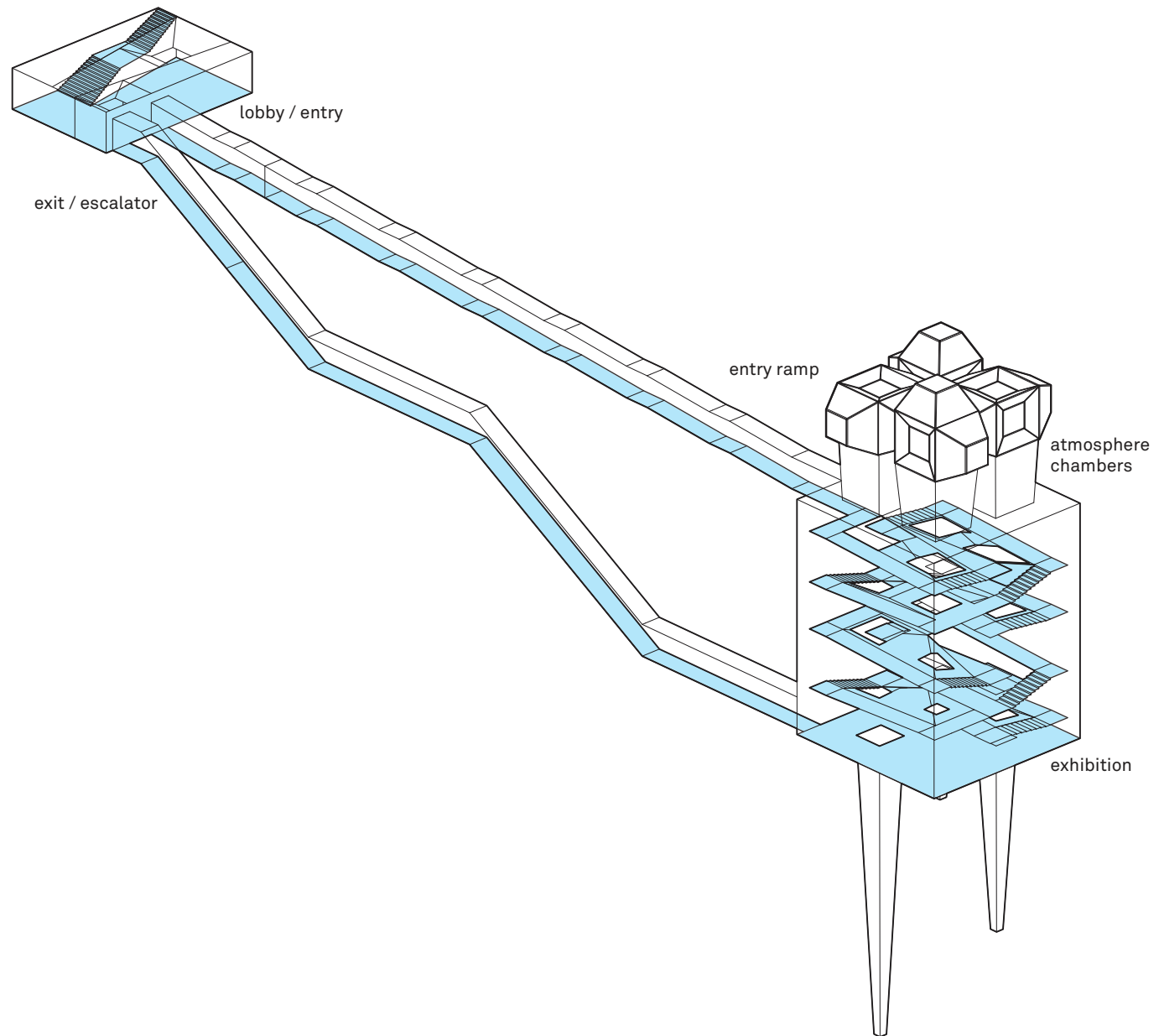

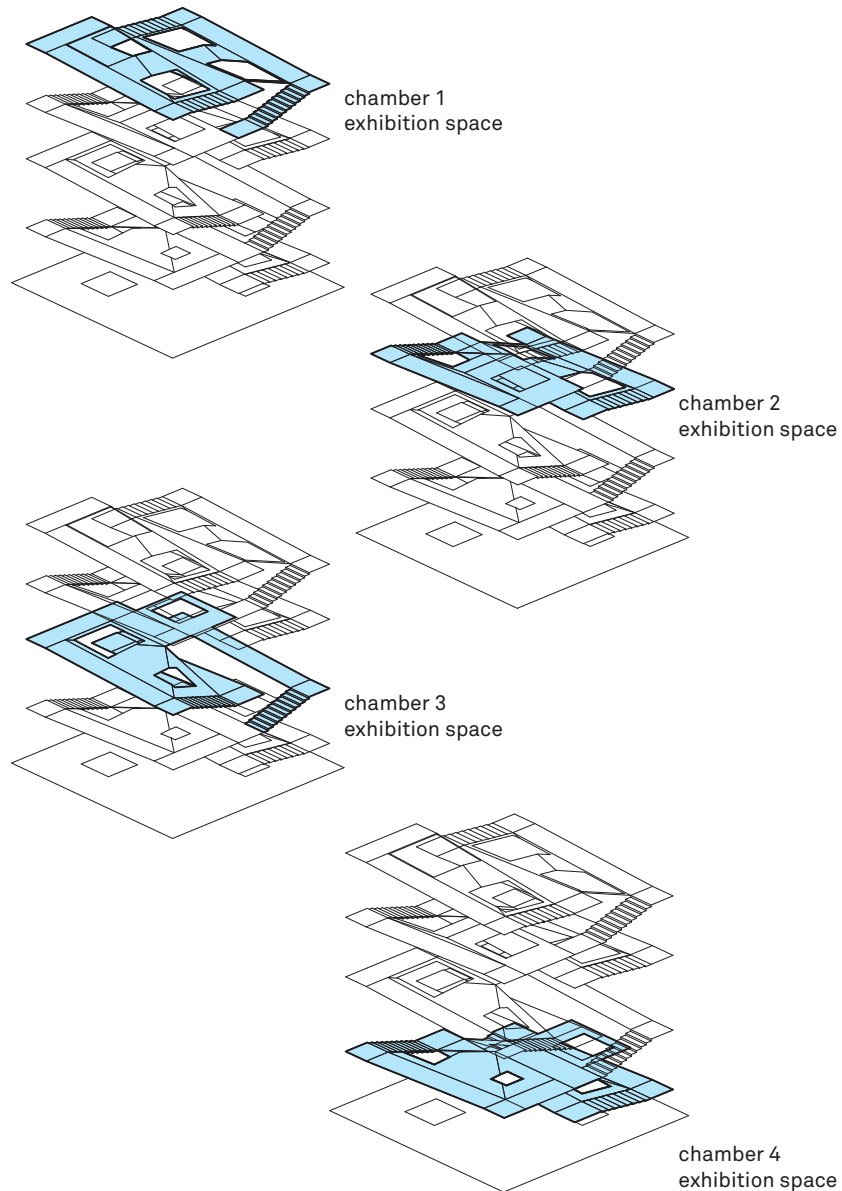

temperature, lighting conditions and sounds.

Each of the four atmospheric chambers is accessed individually through a hydraulic elevator lift. Details of the mechanism can be seen on page 44 and in Section AA'. Sections BB' and CC' show how when the public descends down the entry ramp from the entrance, they circulate pass each of the four elevator shafts. The attenuated ramp acts as the program space housing the exhibition explaining the environmental conditions for each chamber. Each coil of ramp terminates at a platform from which visitors can then take the hydraulic lift into the weather chambers above ground level.

The hydraulic lifts necessitate an excavation of ground deeper into the earth in order to compensate for the mechanical space needed to house the piston's full range of motion. Visitors walk onto the lift platform which is flush with the rest of the exhibition hall's floor plates. Glass railings rise to act as guardrails for passengers as they are lifted into each of the locked chambers above. As shown in section, the glass shafts act not only as conveyance for the lifts, but also as light wells which illuminate the underground museum by acting as the cores orchestrating the weaving of the pre-cast concrete floor plates.

Once visitors enter a chamber, the platform on which they stand acts as the locking mechanism sealing off the weather chamber. As visitors are taken back down, they experience each chamber and exhibition space in sequence, becoming acutely aware of how many chambers are left with each descent. The exhibition terminates when the public reascends up a more expedient escalator back to the archive entrance.

### Hydraulic Lift Components

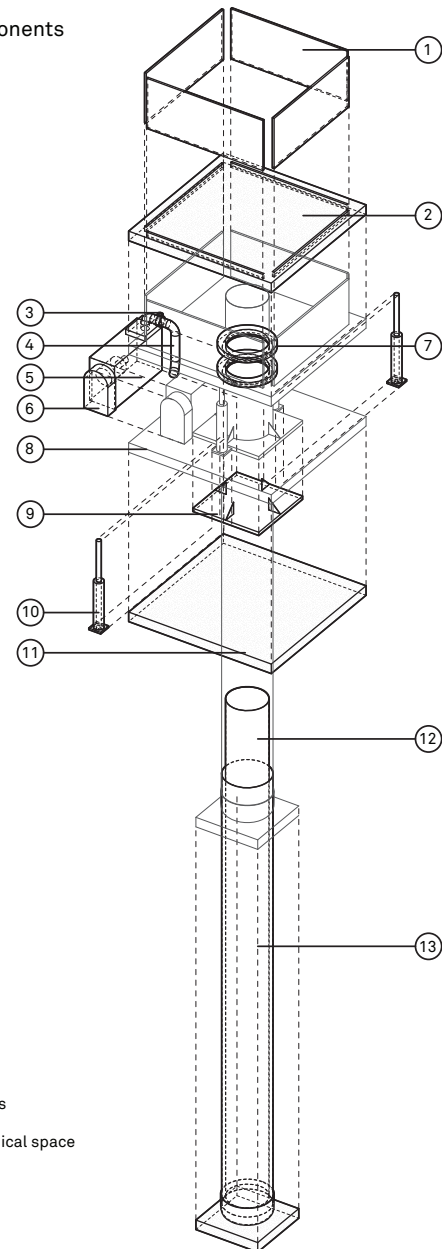

- 1. glass railing
- 2. hydraulic platform
- 3. fluid valve block
- 4. oil pipe
- 5. tank
- 6. electric motor pump
- 7. pipe collar
- 8. railing lift
- 9. cylinder support plate
- 10. hydraulic railing locks
- 11. hydraulic lift mechanical space
- 12. piston
- 13. pvc cylinder

### Hydraulic Lift Conditions

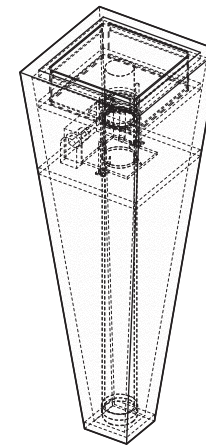

hydraulic elevator volume

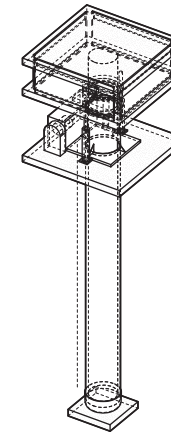

railings lowered

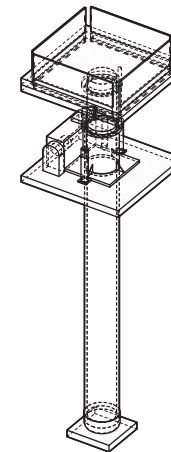

railings extended

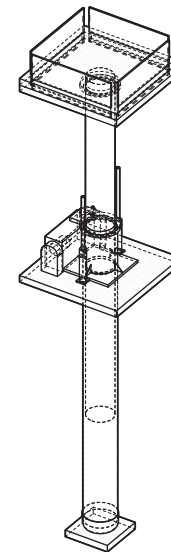

platform extended

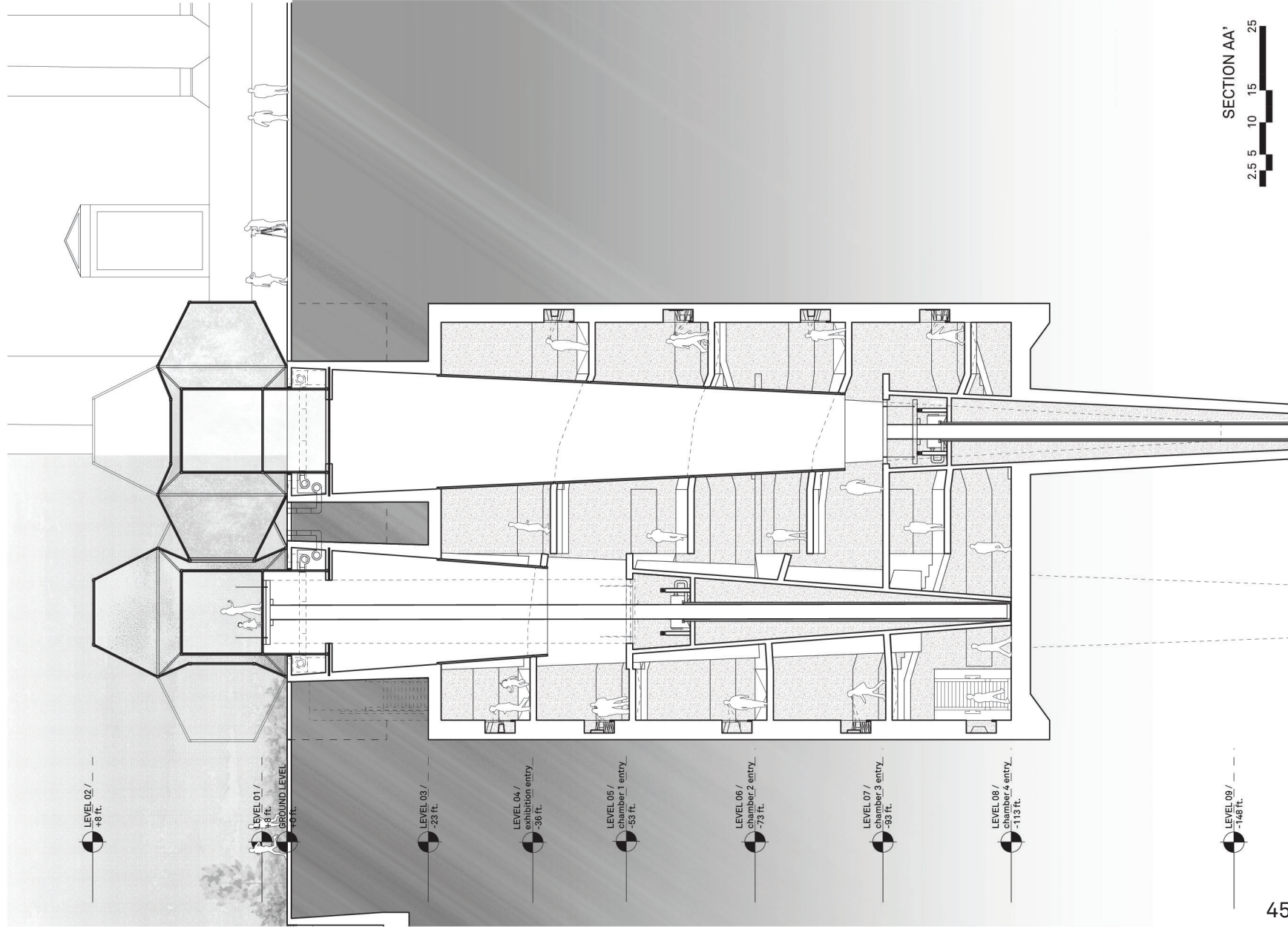

SECTION BB'

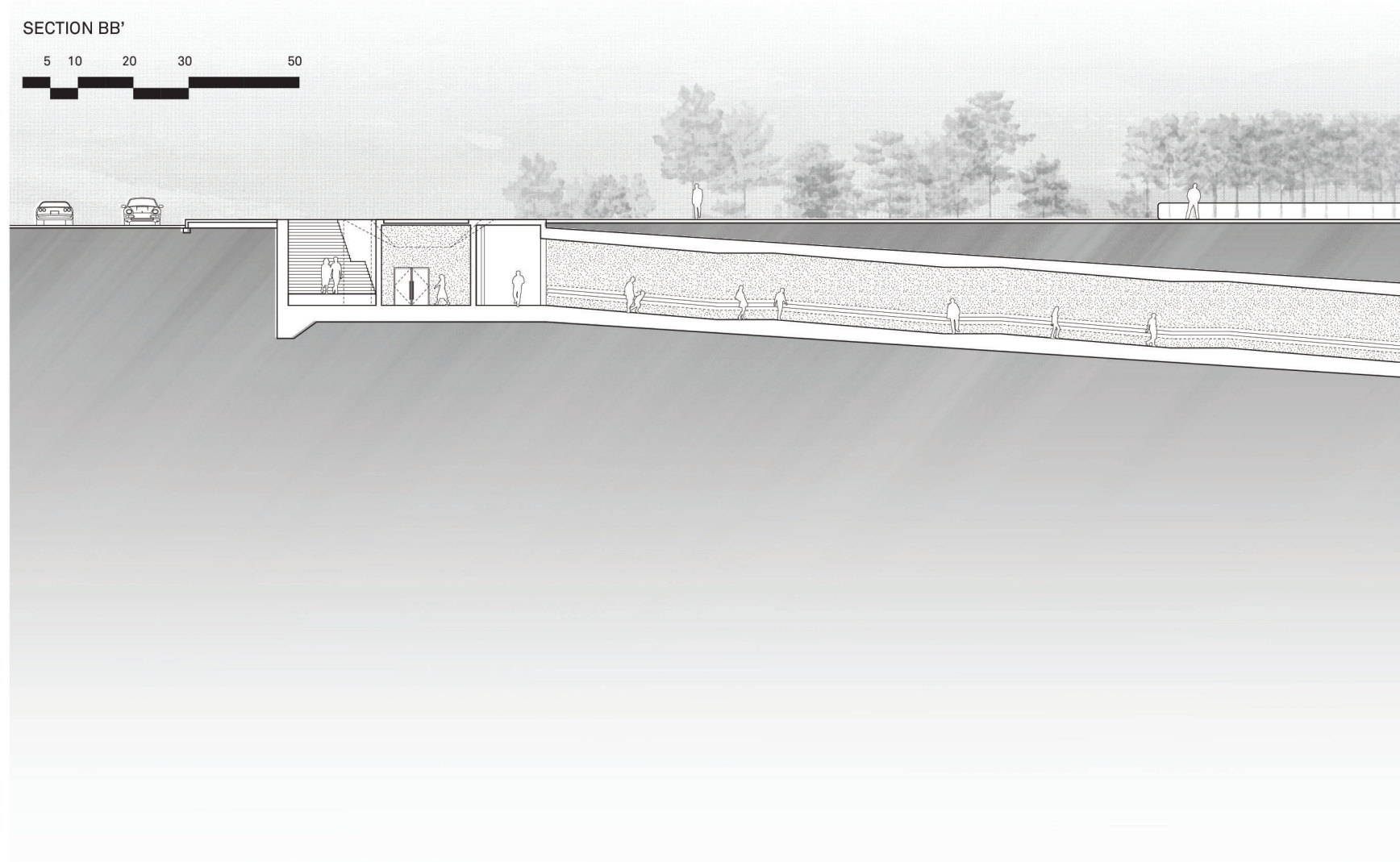
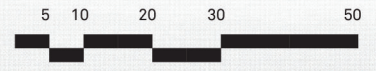

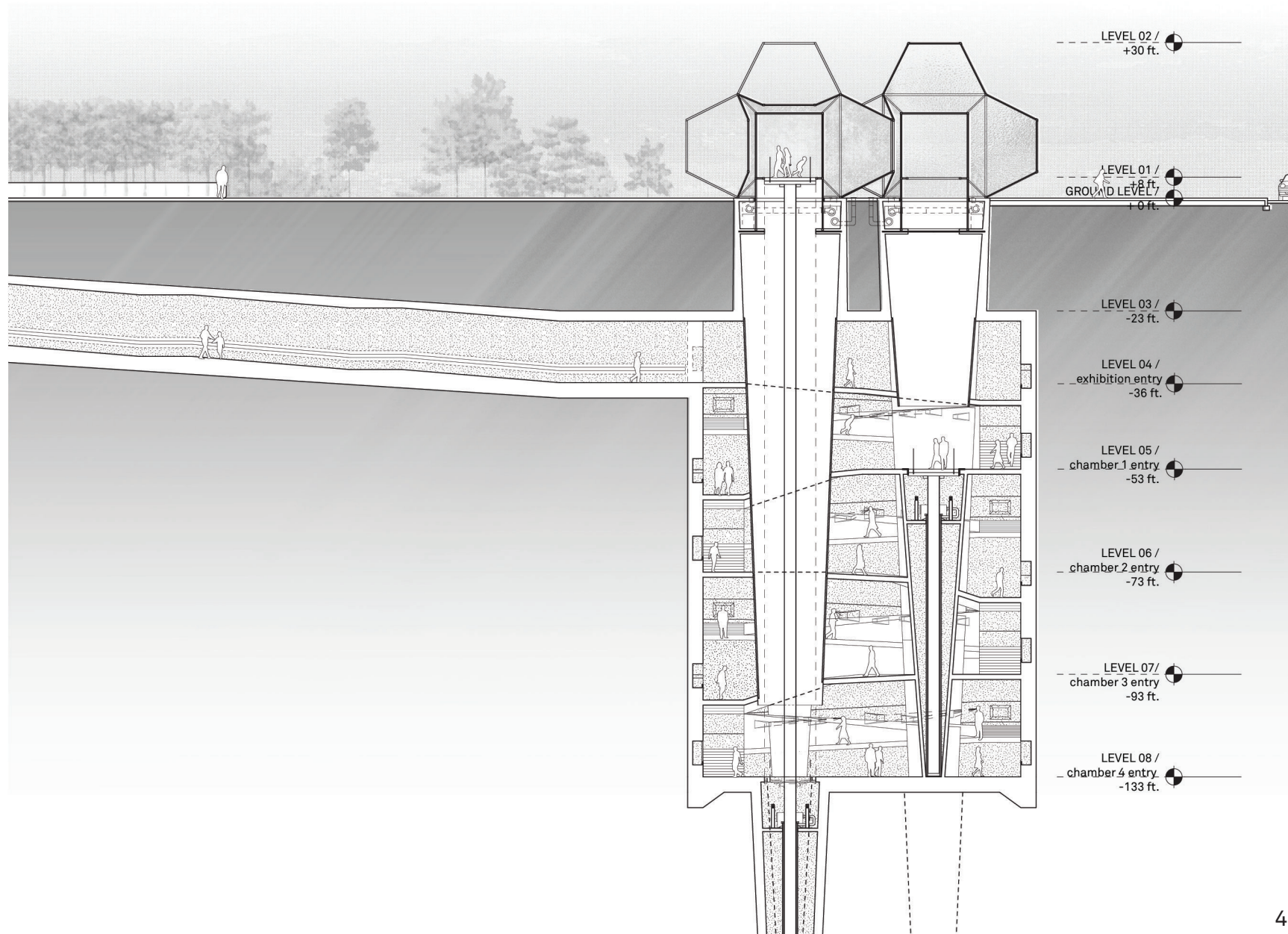

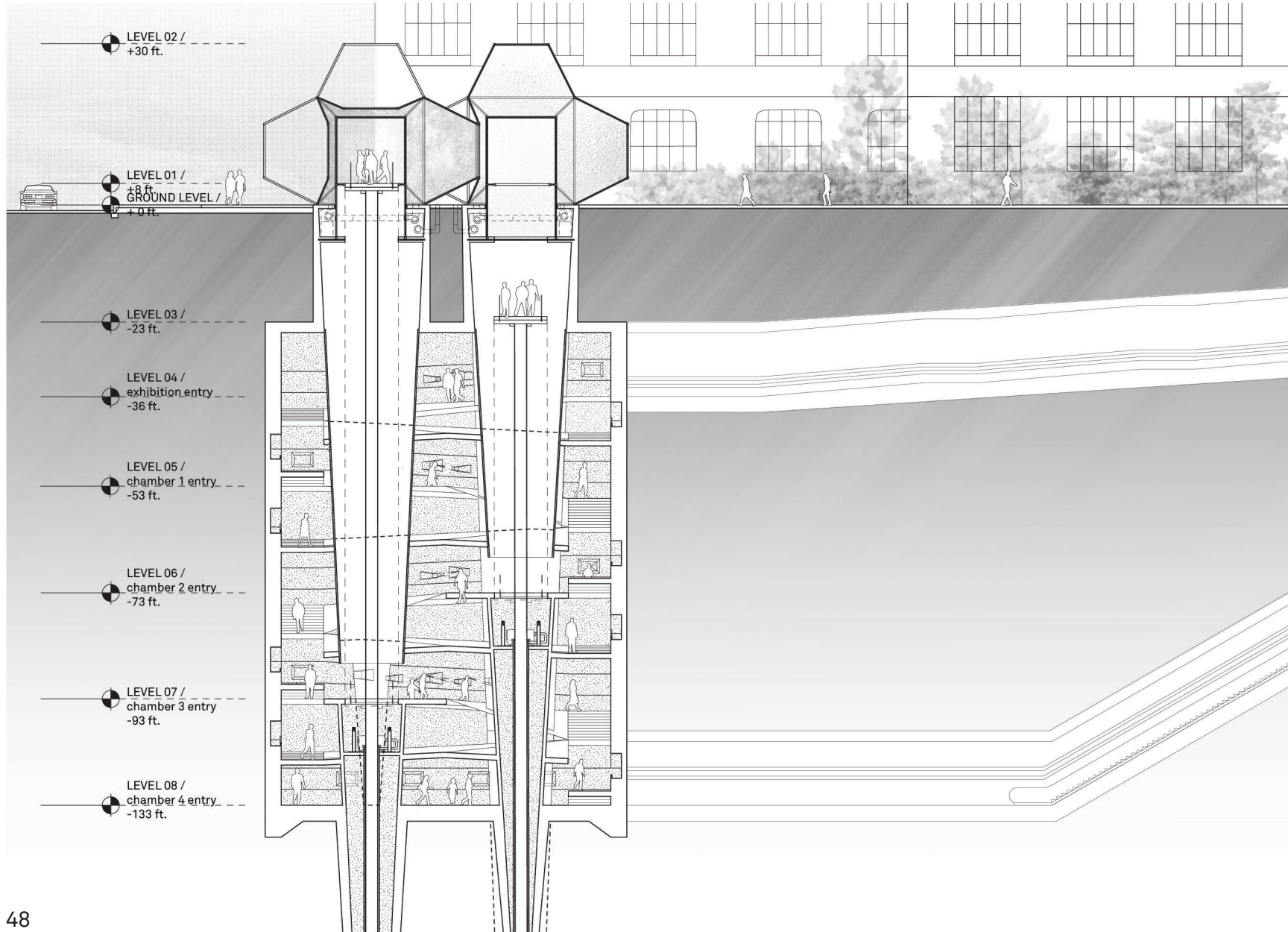

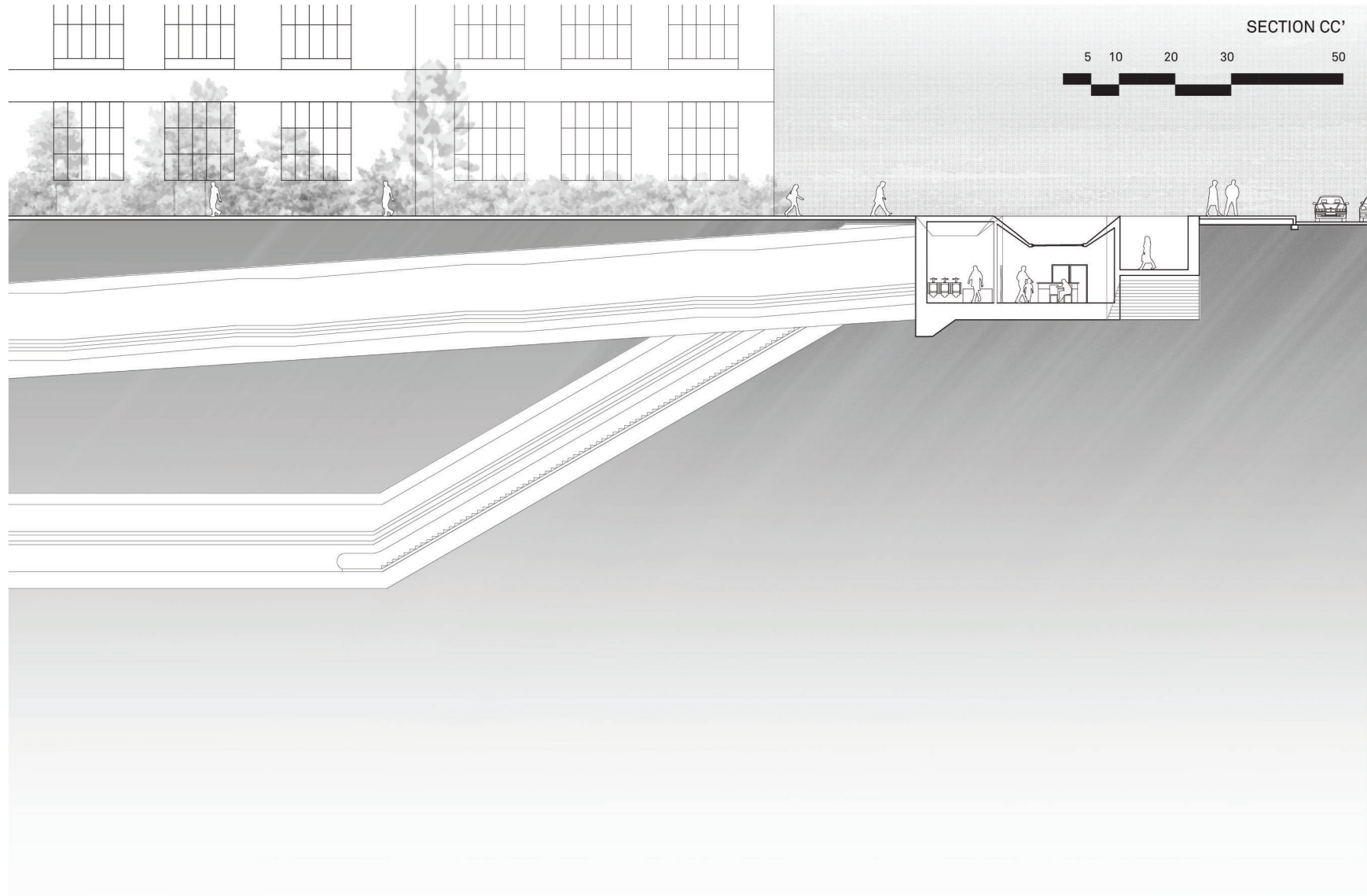

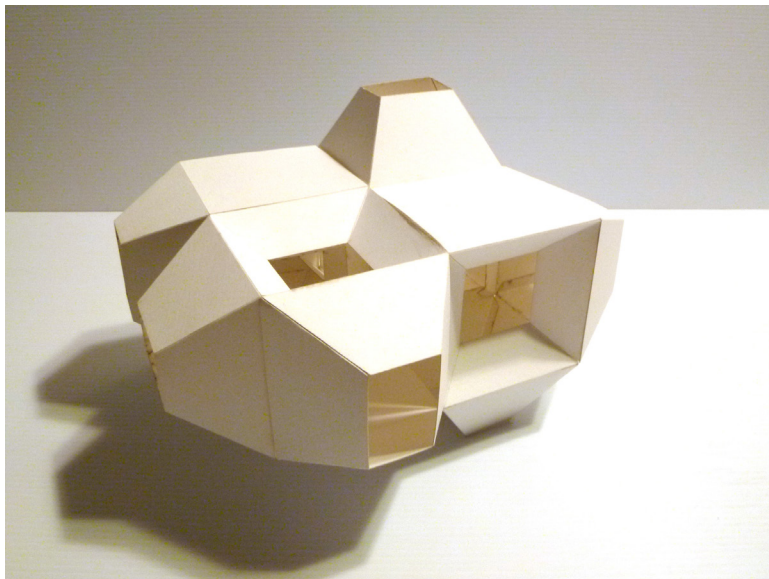
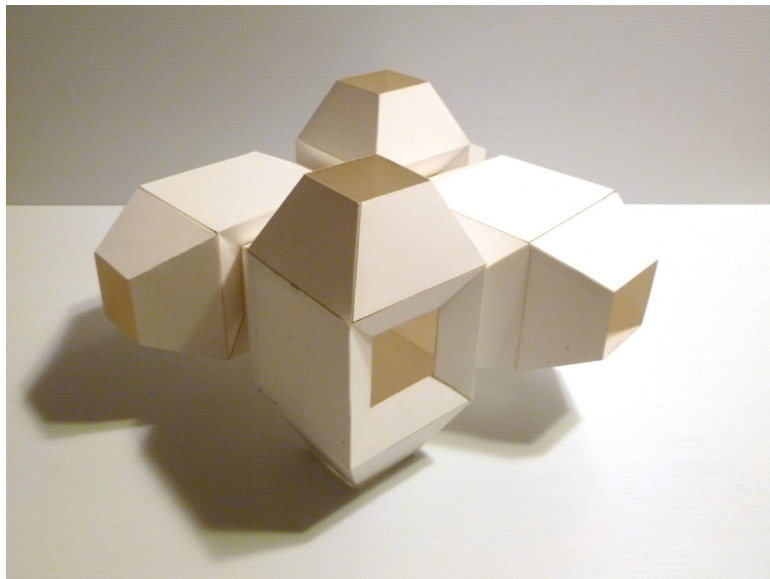
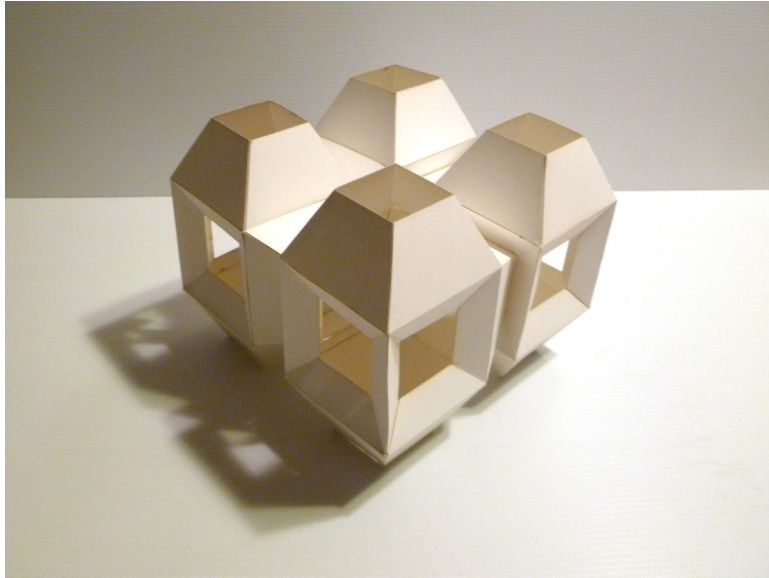
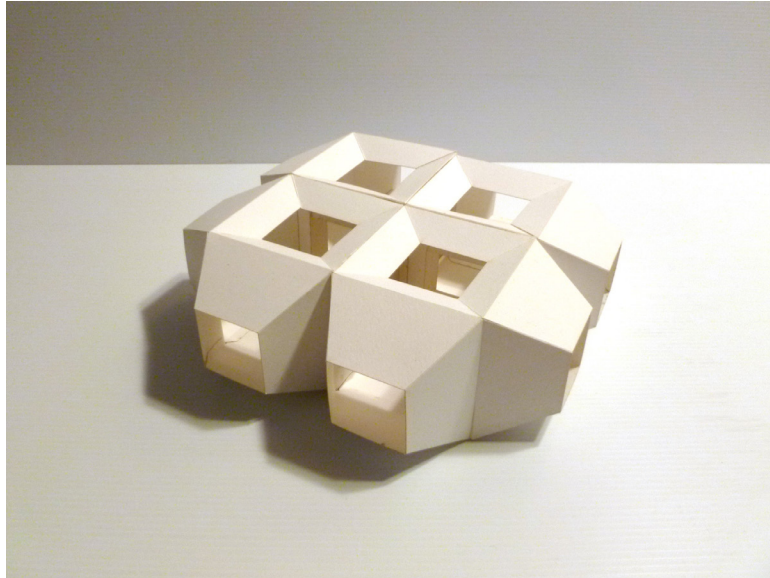

ABOVE: Weather chamber configuration studies.

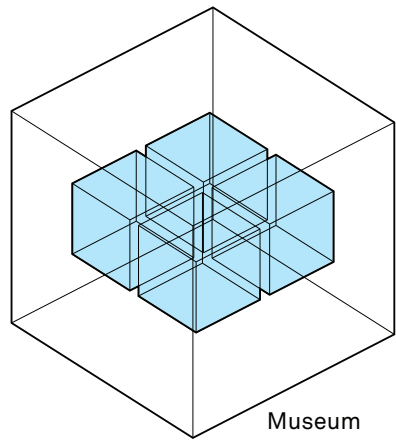
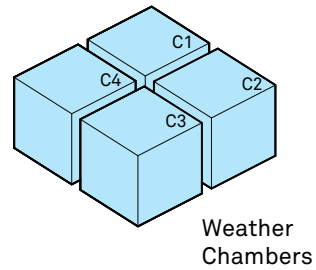

## WEATHER CHAMBERS

The design of the weather chambers privileges the view. As the archive's dark underworld isolates the public's understanding of the exterior environment, their re-emergence into each of the glass chambers presents a moment to create a new view or understanding of their environment.

Each chamber organization tested the limits of providing entry and exit, views onto the other chambers and views of the outside D.C. grounds (see adjacent pages). These views create the condition where visitors can thermally experience one environment while looking into another. This activates the visitor's curiosity with regards to the other chambers while juxtaposing the senses. The following pages describe the results of different configurative exercises through drawings and models. The resulting organization contrasts what visitors may feel through temperature and humidity changes with a view of the future or historical "exterior" generated through the chamber's HVAC systems.

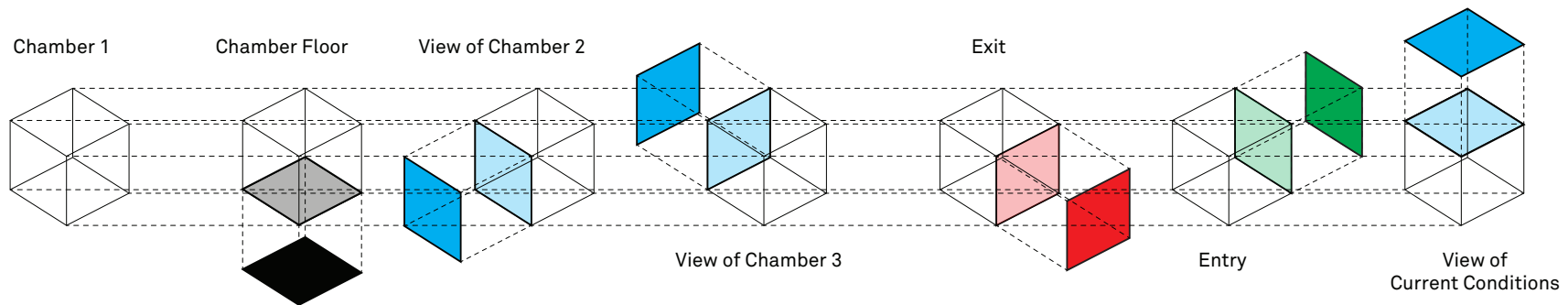

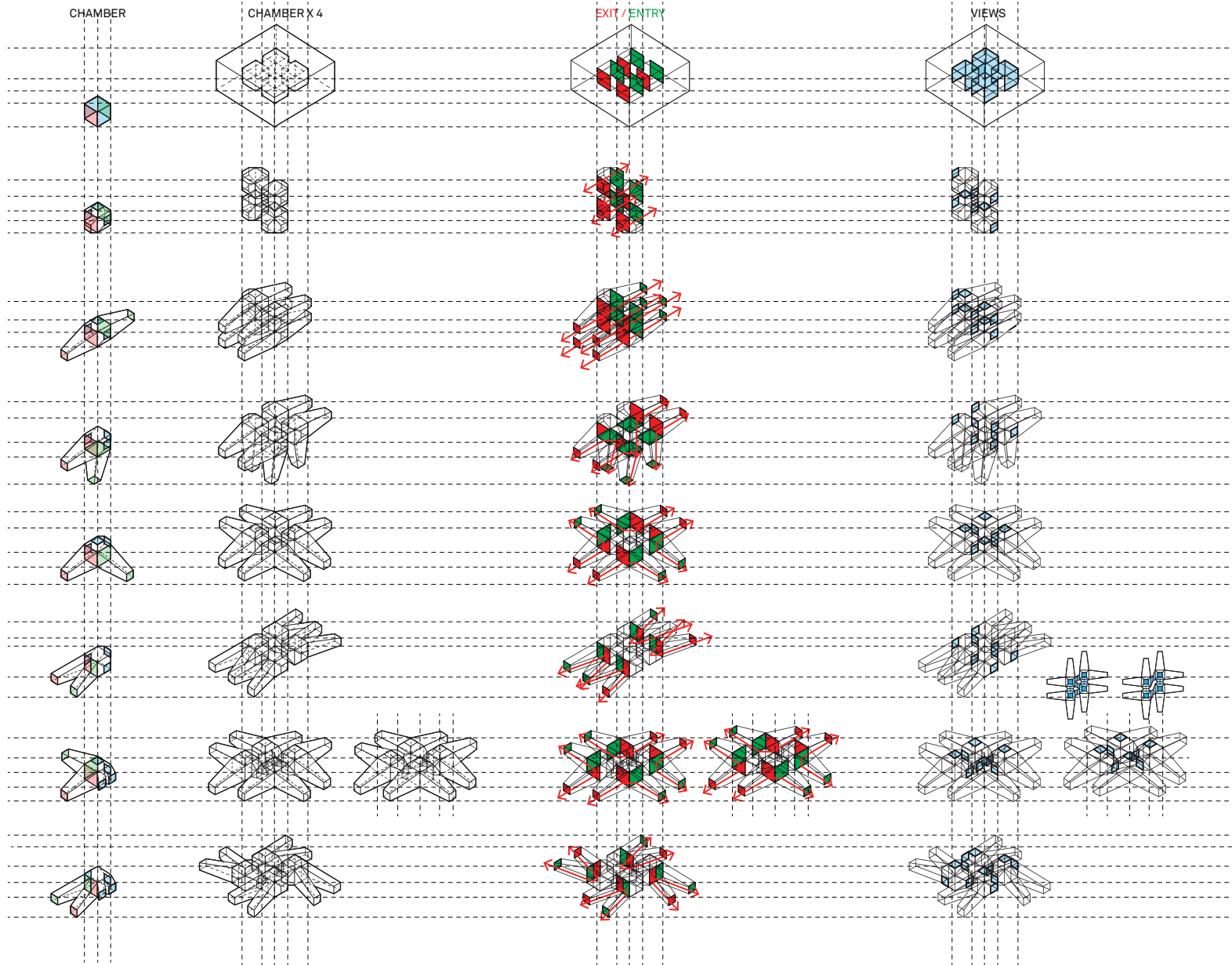

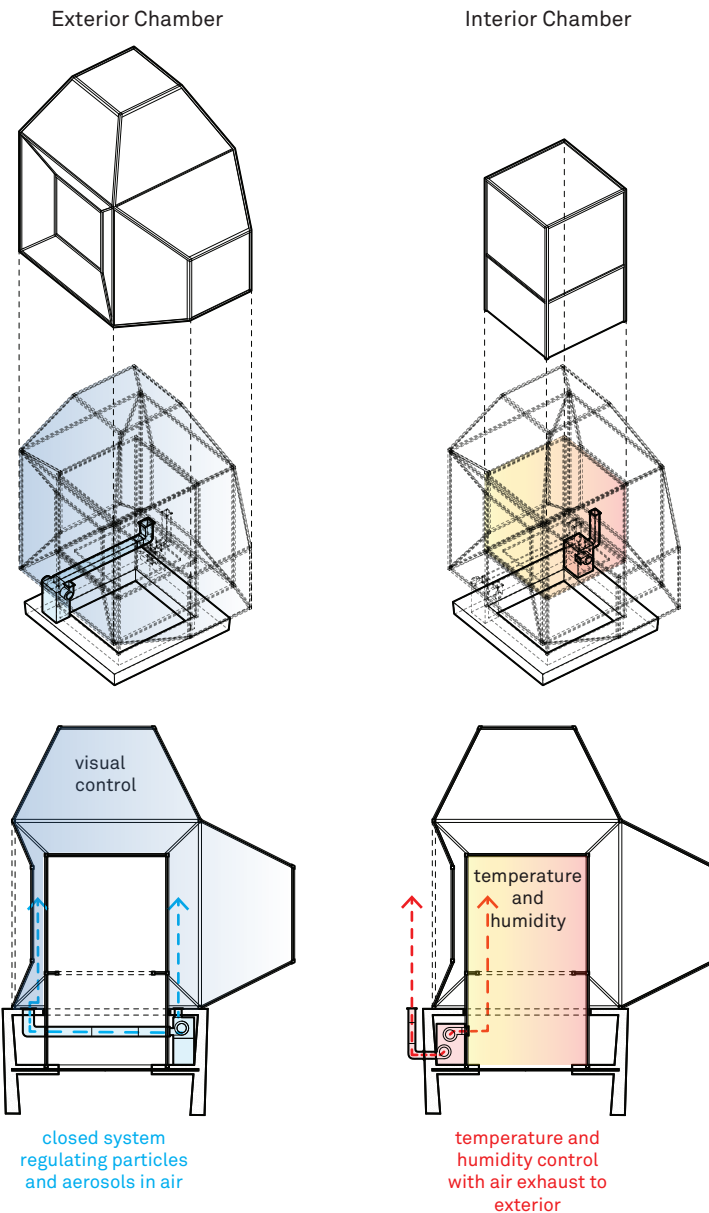

The use of glass as the chamber envelope serves two purposes. One, in conjunction with the system of thin, steel members, is to create an invisible, contained environment from which visitors can view the exterior and through which they, themselves can be viewed. The second is to create the poche space for regulating the particles and aerosols which may be pumped into the first layer of the chamber to create the visual control of the chamber. The exterior chamber's HVAC system is closed, circulating the dust, smog or moisture impacting the chamber's depth of vision. This poche also acts as the insulation layer for the tightly controlled temperature and humidity occurring within the interior chamber layer.

As with all modern building systems, the temperature and humidity is controlled through HVAC. However, in *HYPERsensarium*, it is the forgotten and future exterior conditions which are inverted for public experience. What once were considered "outside" conditions have become interiorized phenomena.

System Components

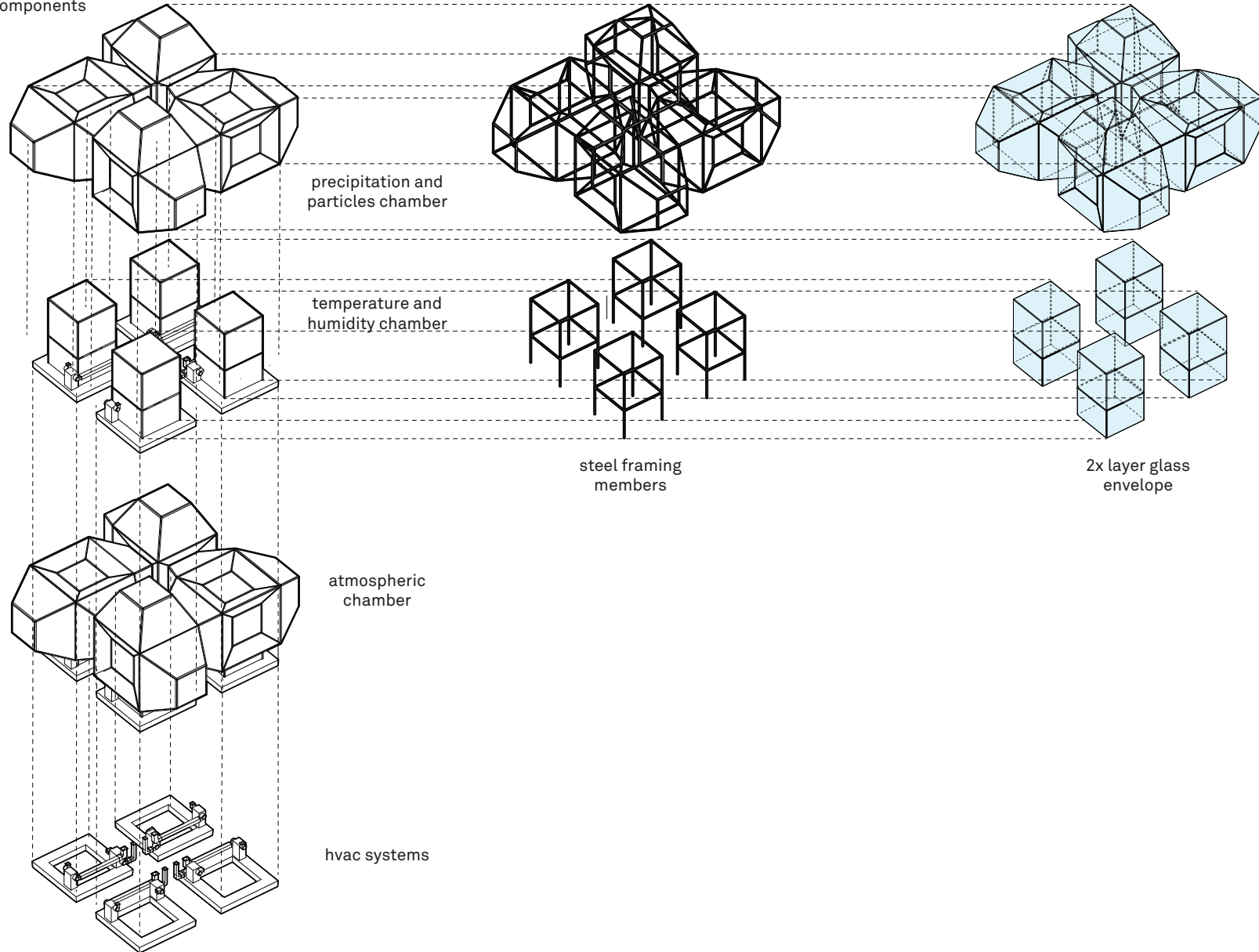

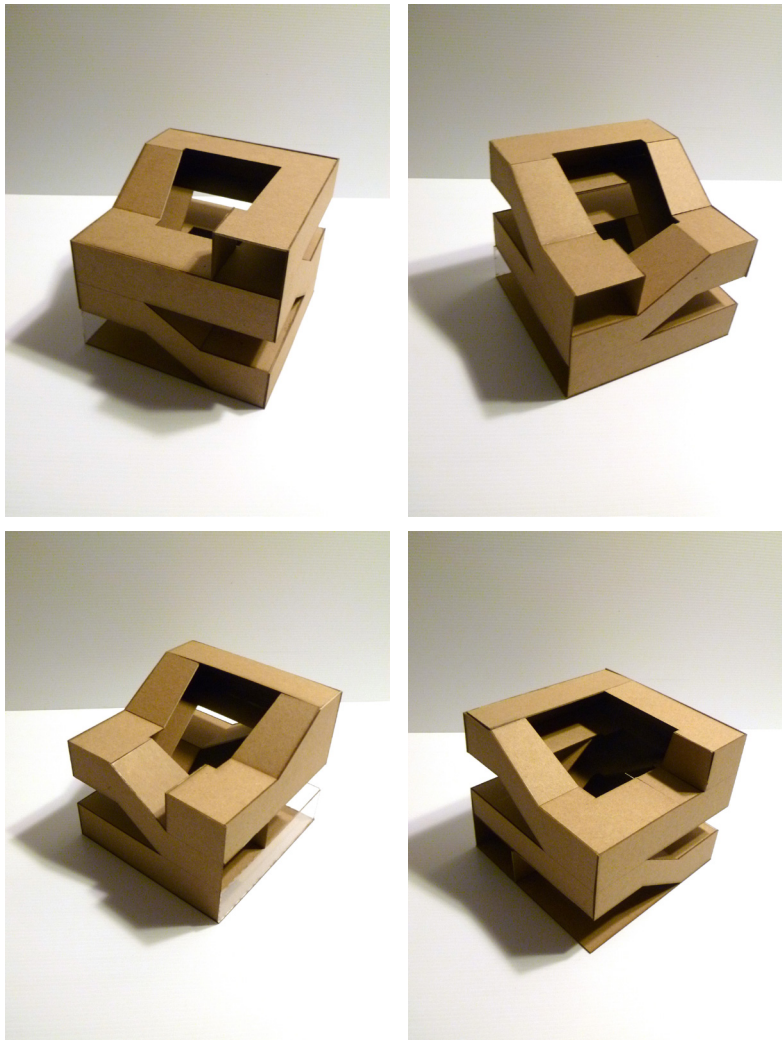

ABOVE: 1/4" exhibition ramp studies.

## ATTENUATED EXHIBITION

**HYPERSensarium challenges the traditional static nature of museum exhibitions while striving to avoid the kitsch of modern interactive museum displays.**

Unlike a traditional museum which is spatially divided into galleries for exhibiting information, the setup for each chamber is explicated by a widened eight-foot ramp. The ramp condition can be best described in the sequence of plans following this section. It tests the concept of HYPERSensarium being an archive through which visitors are constantly circulating through. Rather than physical displays and flat floor plates, HYPERSensarium's exhibition spaces are a coil of ramps with angled LCD screens protruding from the thickened concrete museum walls as seen in plan and section. The ramp width allows visitors to pass quickly through the exhibition while providing the space for simultaneous lingering in front of the display screens. In plan these ramps terminate at each lift level.

Each of the LCD screens features a piece of information regarding the chamber into which visitors are about to enter. For example, smaller screens may flash chamber temperature, humidity and visibility conditions. Larger screens may play a 30-second clip regarding the history of a site or the energy use scenario leading up to a resulting future environment. Collectively these screens form the narrative which visitors can experience in passing while they are in transit between one chamber and the other.

The following pages show an interior elevation of the exhibition space unfolded and two sample exhibition narratives.

Exhibition

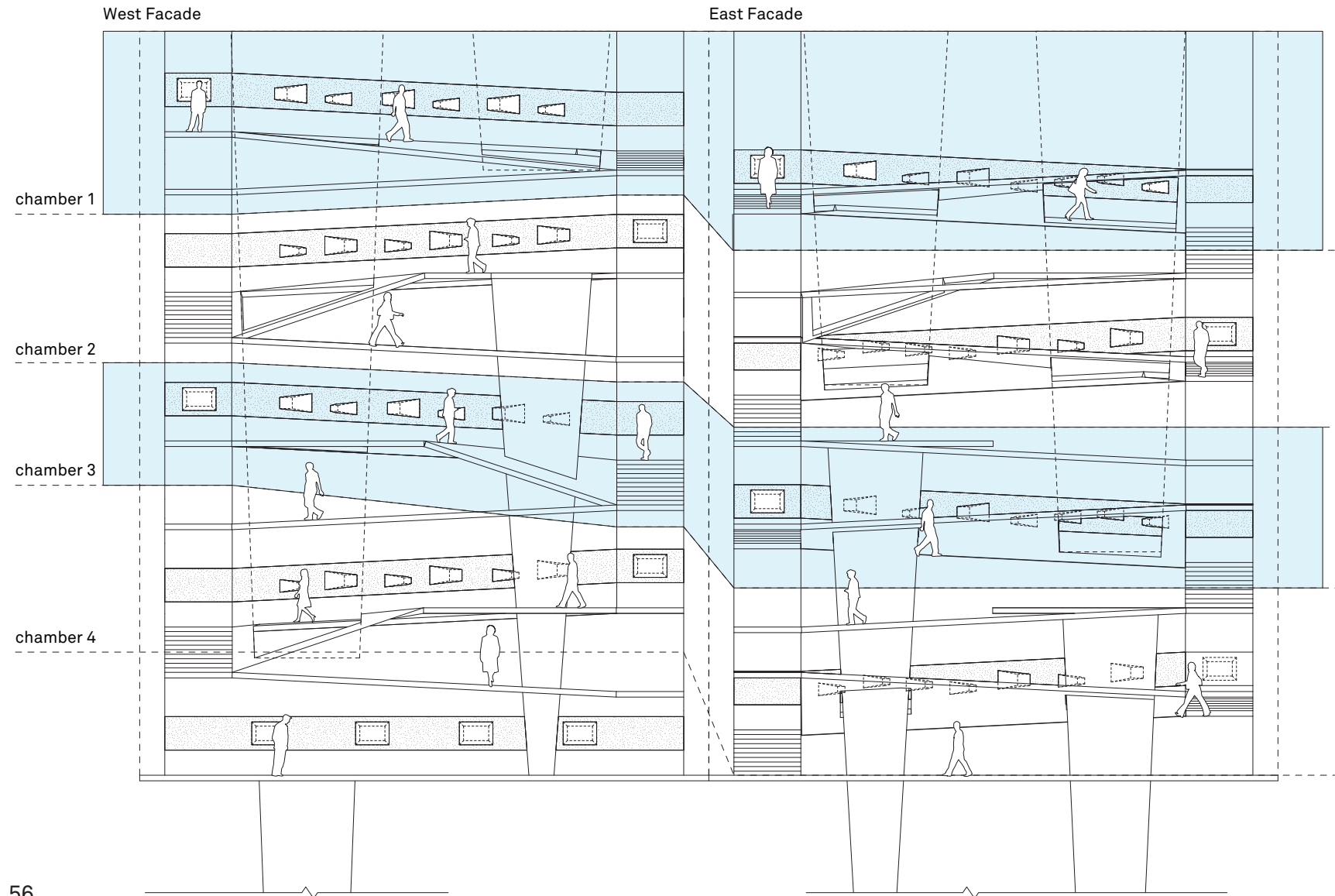

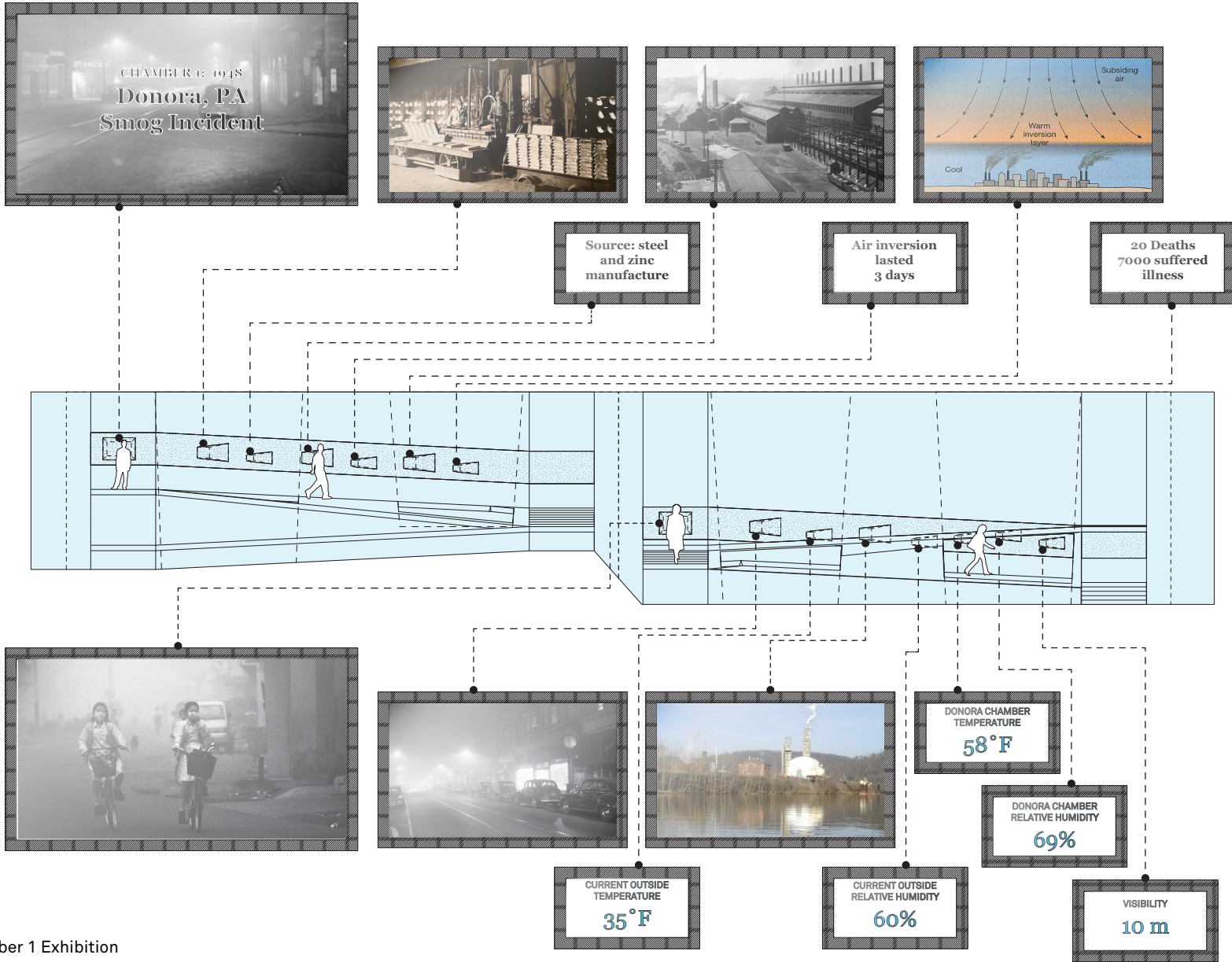

Chamber 1 Exhibition

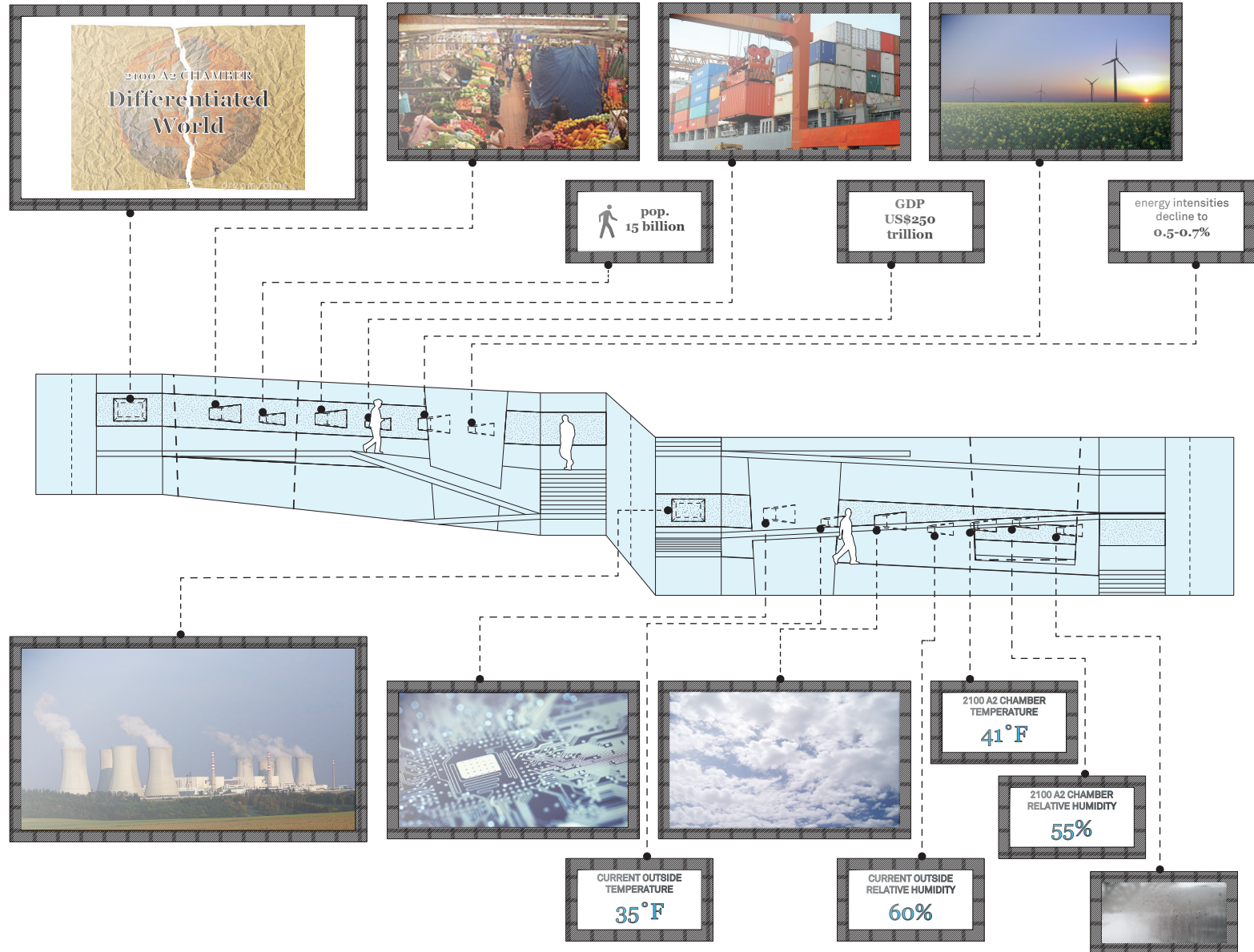

LEVEL 01 /  
chambers

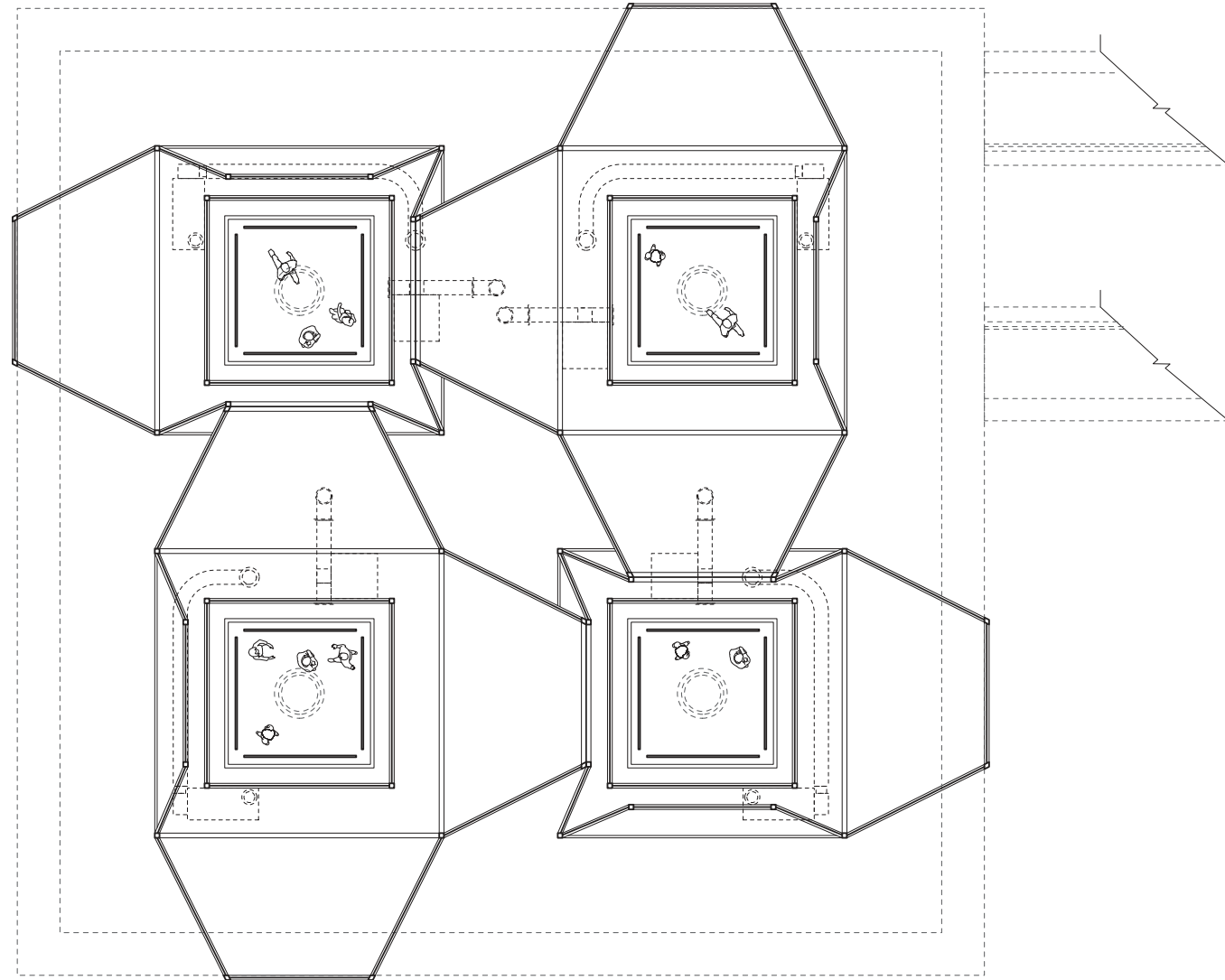

LEVEL 03 /  
entrance



B

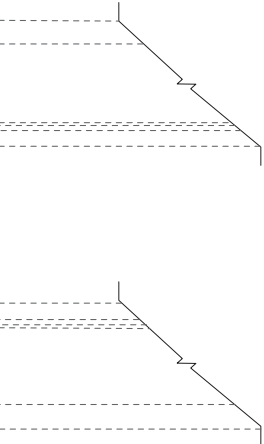
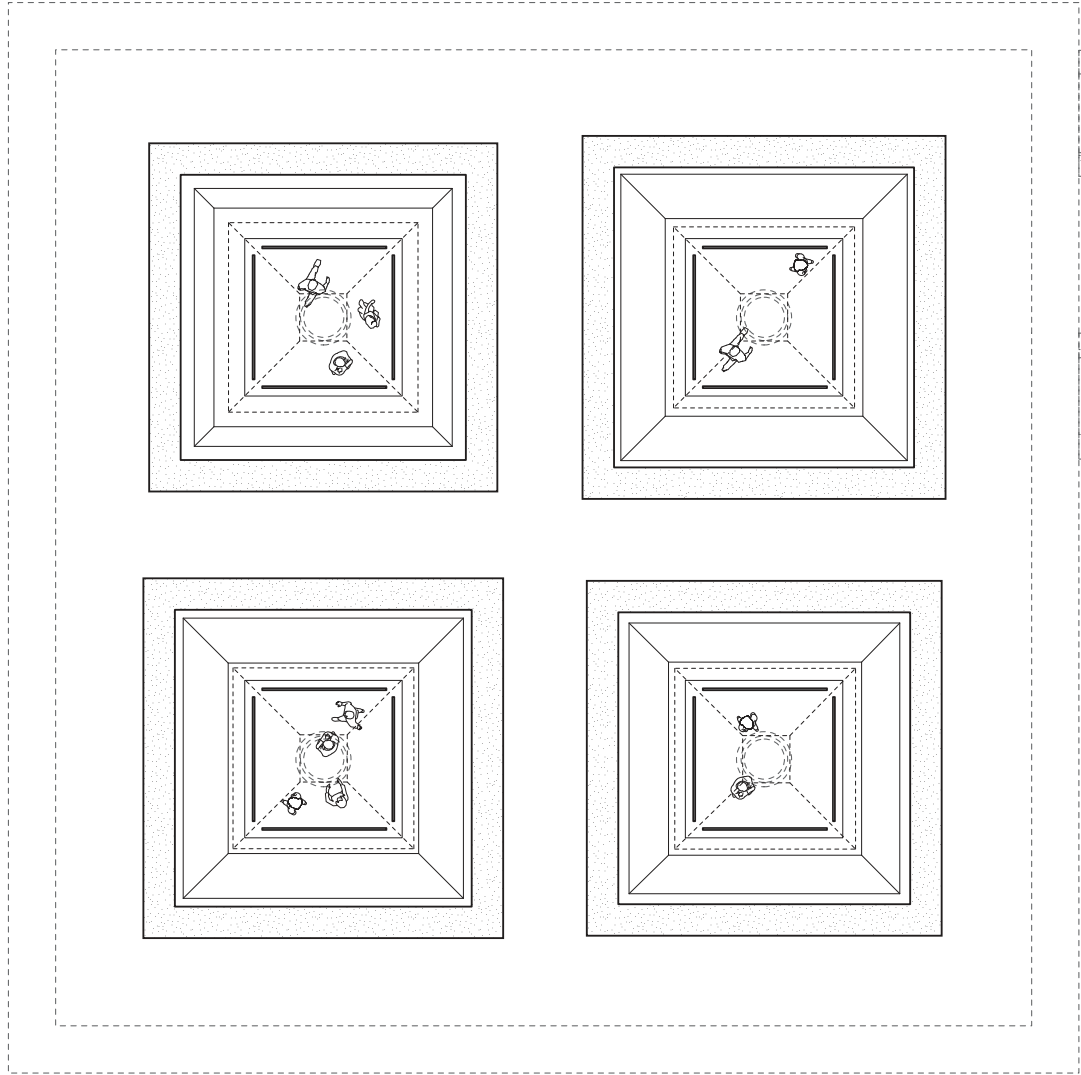

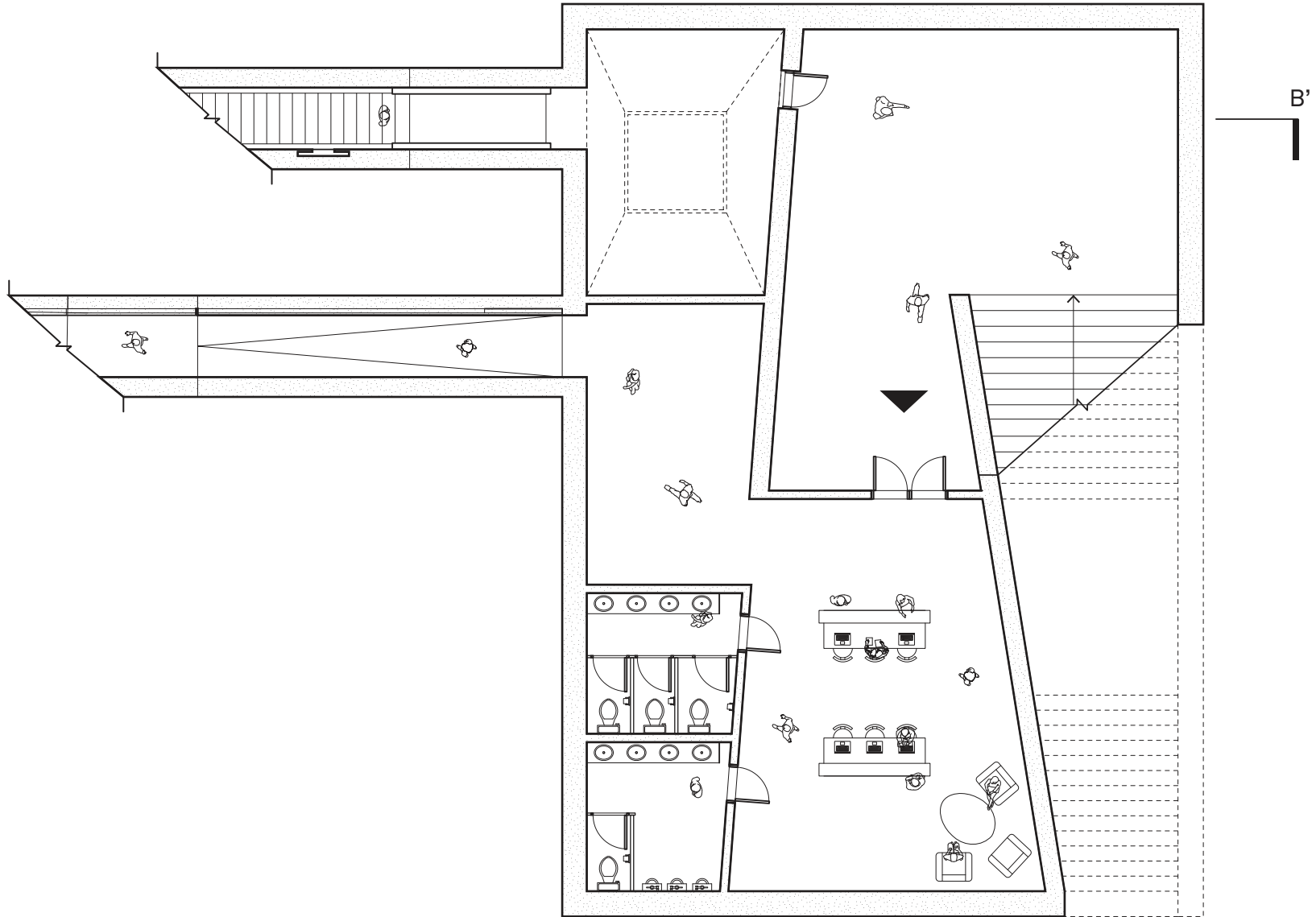

LEVEL 04 /  
exhibition entry

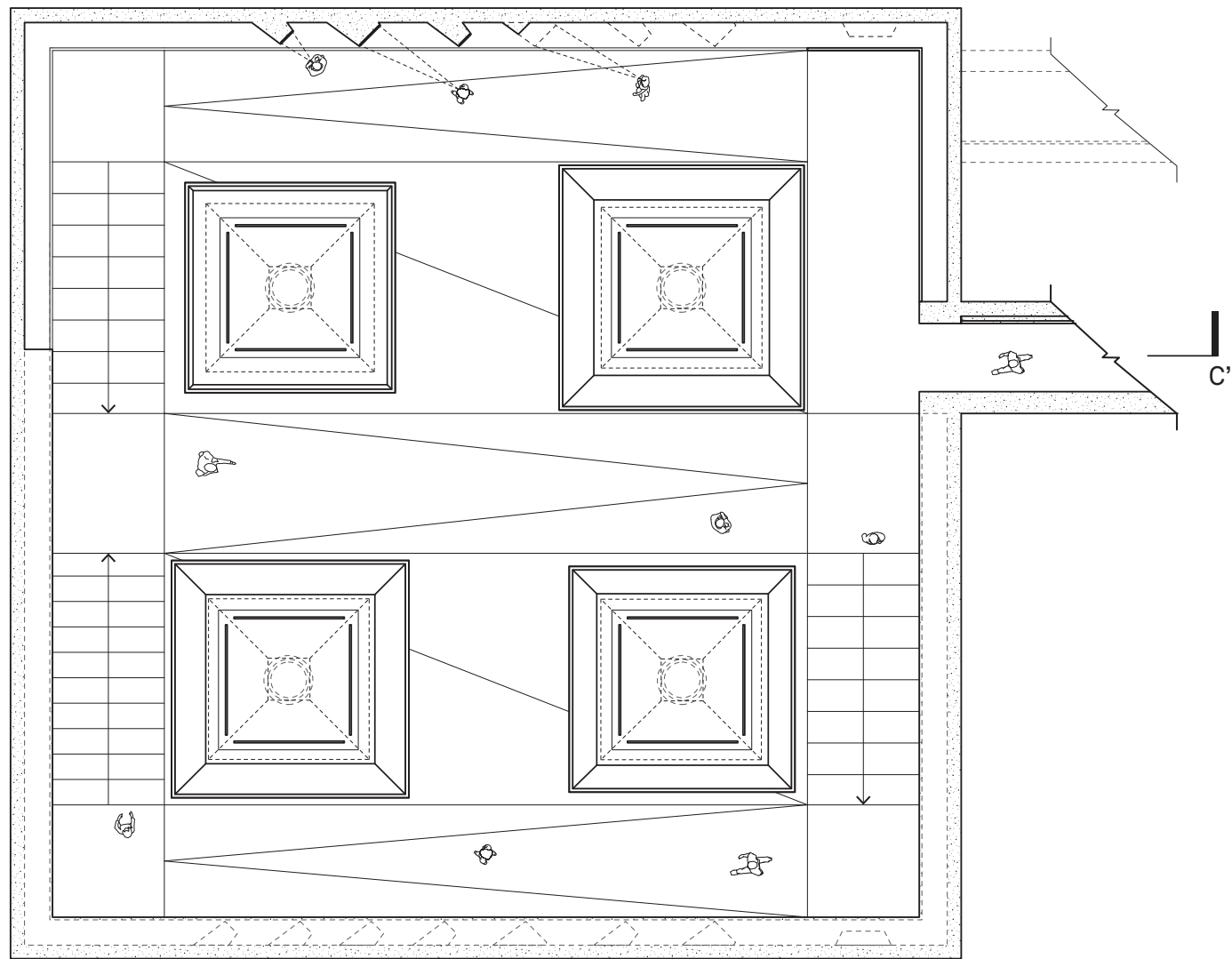
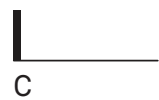

LEVEL 05 /  
chamber 1 entry

— z

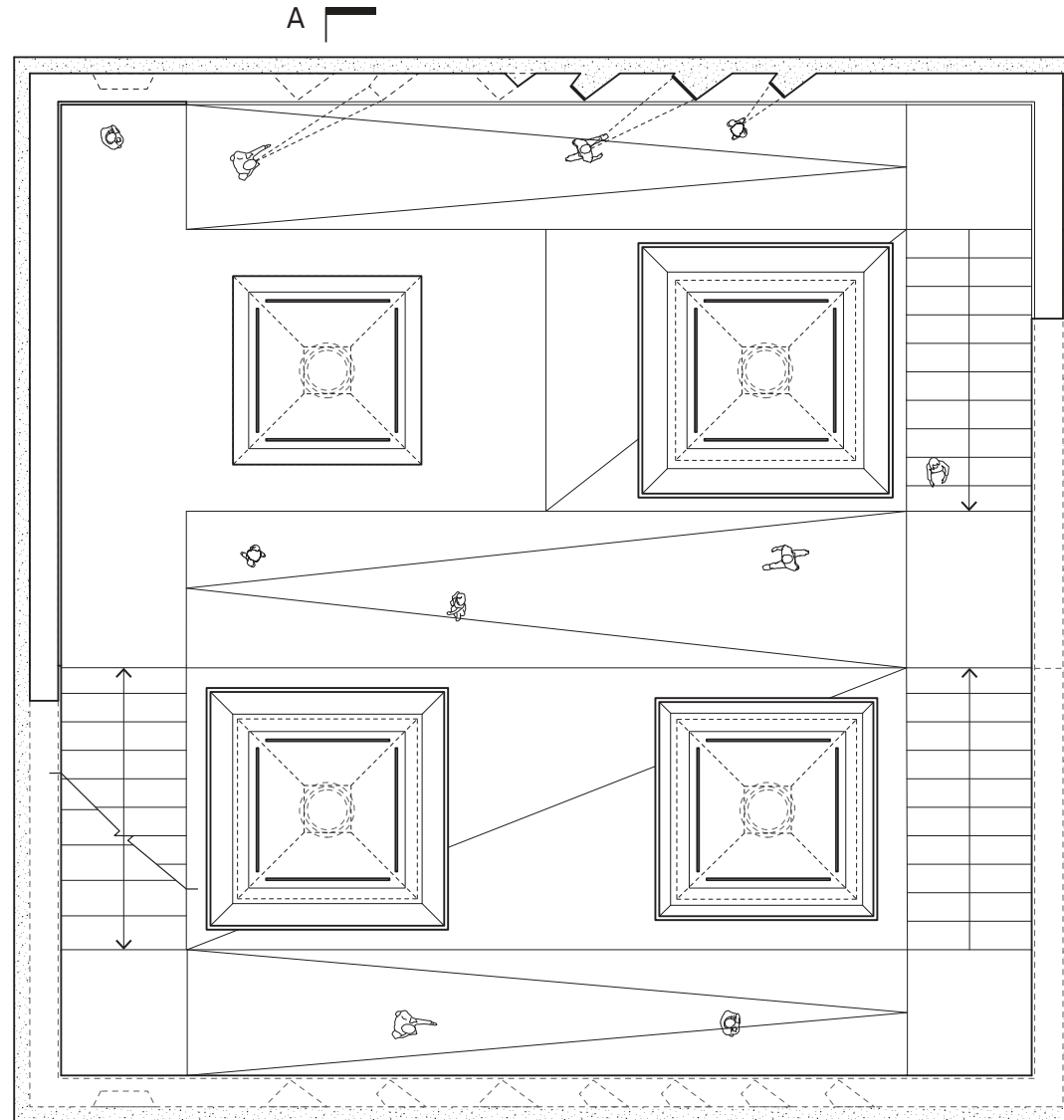

0 5 10 15 25

A'

LEVEL 06 /  
chamber 2 entry

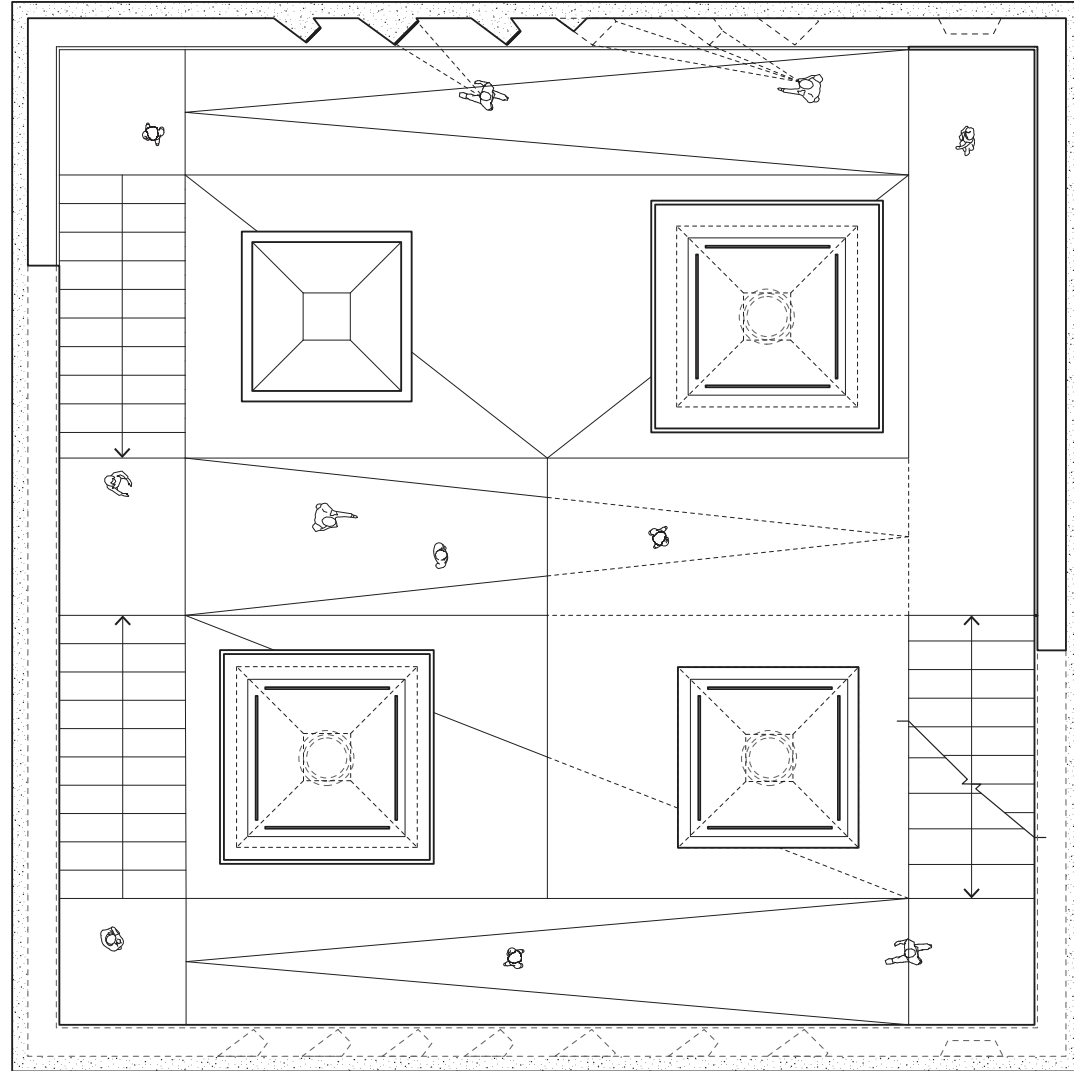

LEVEL 07 /  
chamber 3 entry

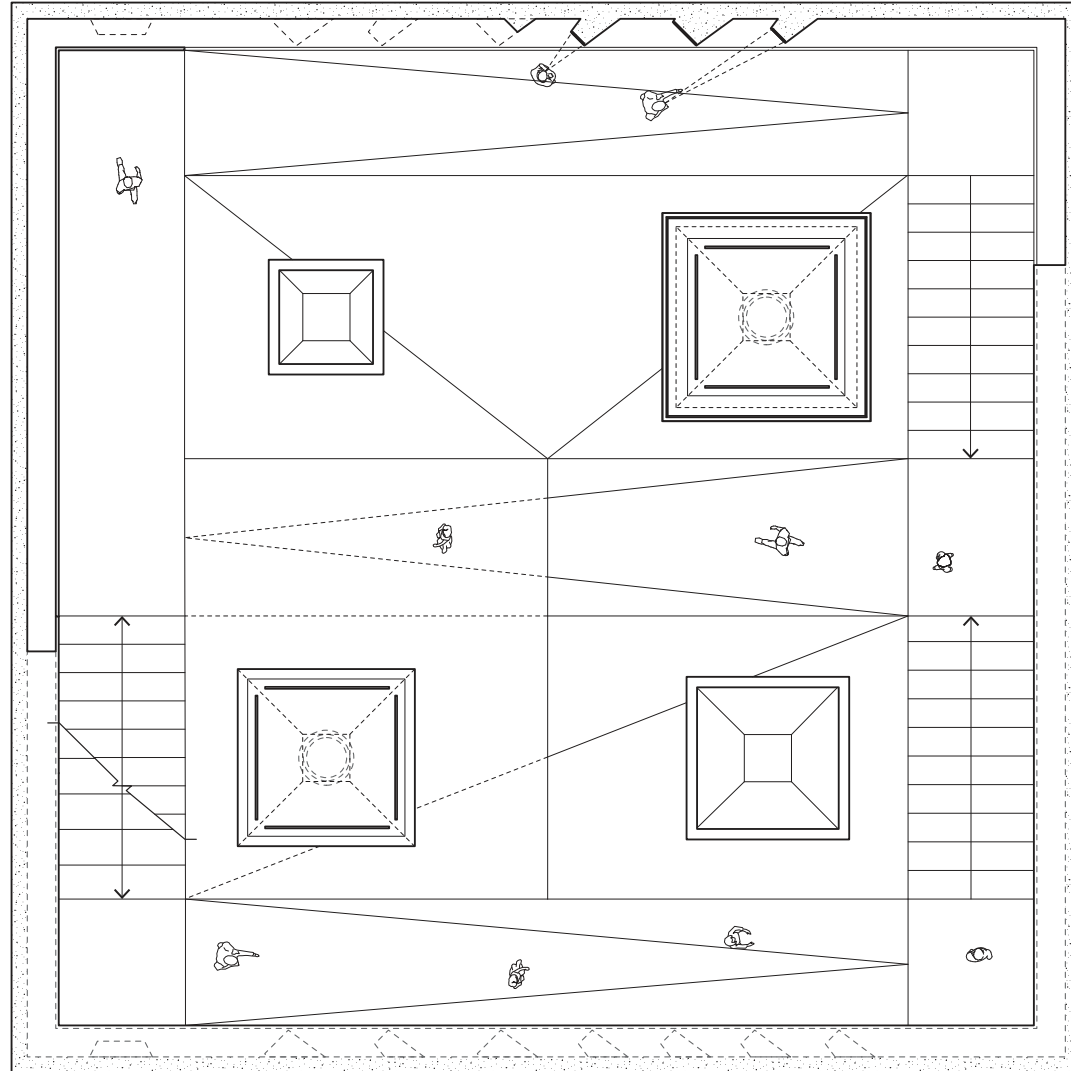

LEVEL 08 /  
chamber 4 entry + exit

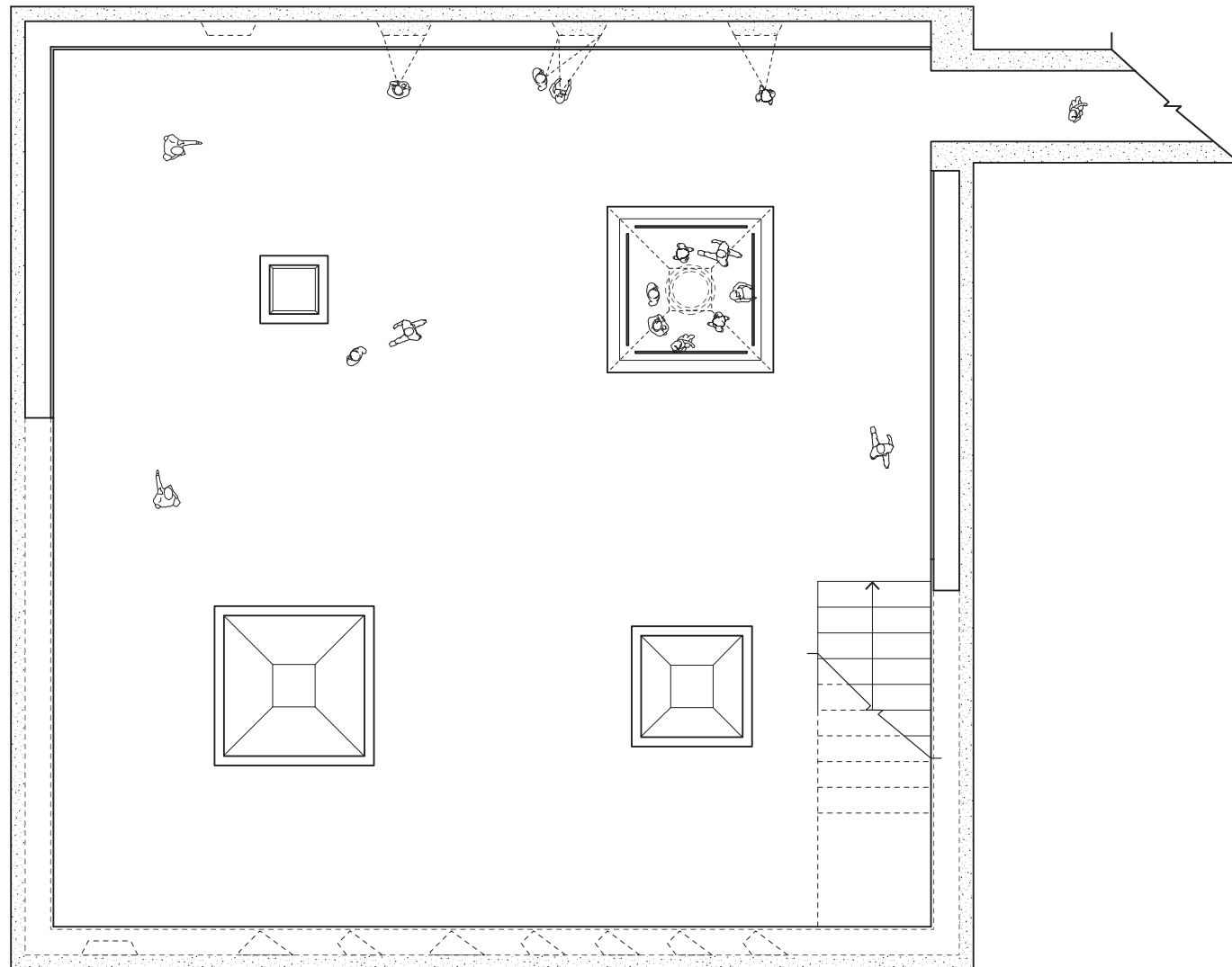

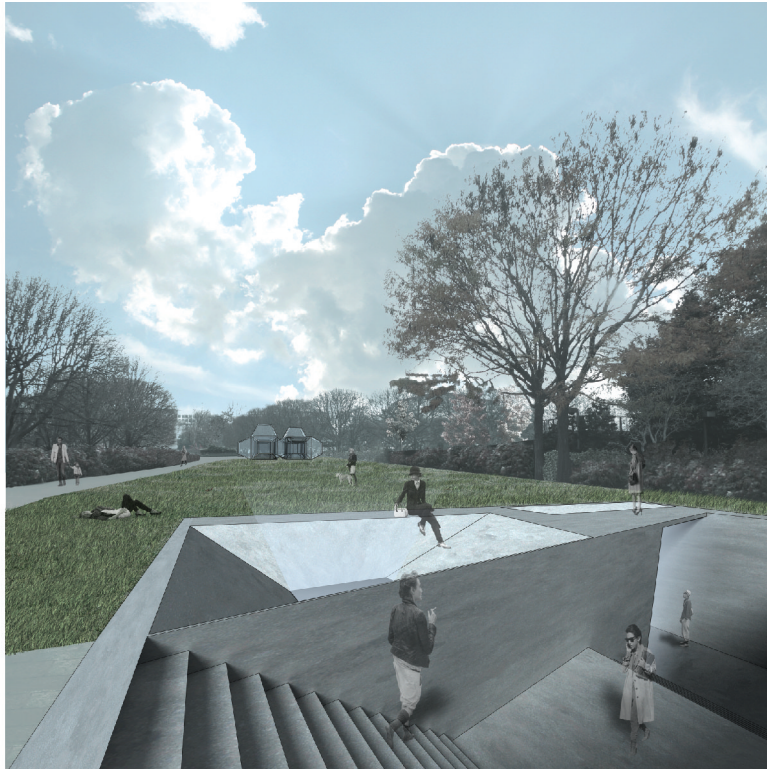

① Entrance

## EXPERIENCING HYPERsensarium

The use of renders was integral to understanding how the visitor's experience of light and temperature changed as they moved from the exterior grounds, into the depths of the archive and into the weather chambers.

1. The public begins at the entrance of the museum where most of the thesis is entirely hidden from view. Only the appearance of the glass chambers on the far end of the park indicate that there must be an entry nearby.
2. As they descend into the narrow, underground tunnel, the public slowly loses sense of orientation, form, scale and dimensions normally associated with above-ground architecture. The tunnel is illuminated by slivers of lighting embedded into the concrete railings of the tunnel and terminates in an illuminated doorway.
3. The tunnel opens into an expansive concrete exhibition space. As the public descends down the ramps, they stop to view snippets of information being presented from angled LCD displays.
4. The exhibition space is lit by light wells formed by glass elevator shafts. As visitors move between the elevator shafts, they can see movement within them as passengers ascend and descend from the weather chambers.
5. Each ramp sequence terminates with the opportunity to ascend into the accompanying weather chamber via a hydraulic elevator lift.

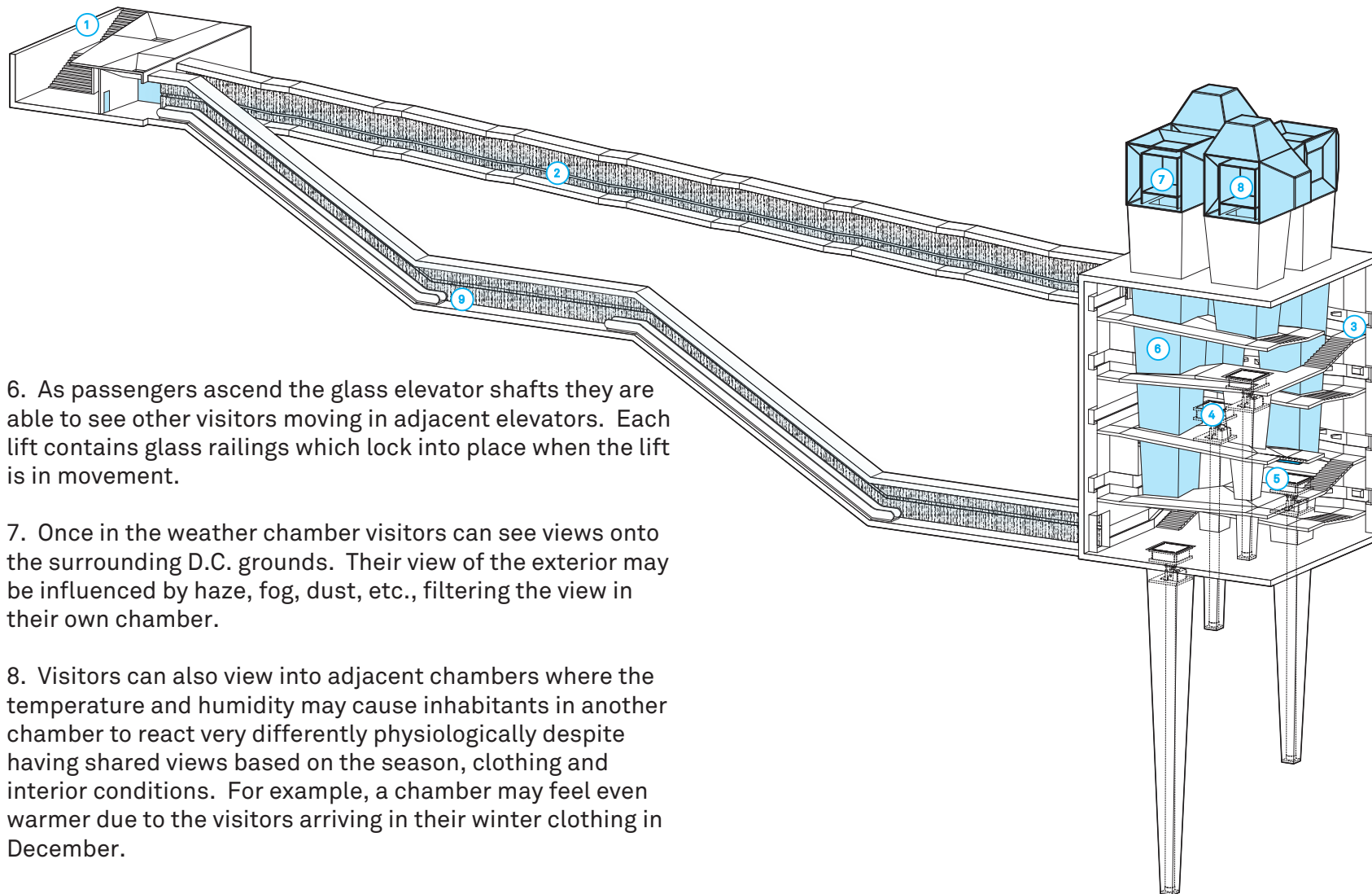

6. As passengers ascend the glass elevator shafts they are able to see other visitors moving in adjacent elevators. Each lift contains glass railings which lock into place when the lift is in movement.

7. Once in the weather chamber visitors can see views onto the surrounding D.C. grounds. Their view of the exterior may be influenced by haze, fog, dust, etc., filtering the view in their own chamber.

8. Visitors can also view into adjacent chambers where the temperature and humidity may cause inhabitants in another chamber to react very differently physiologically despite having shared views based on the season, clothing and interior conditions. For example, a chamber may feel even warmer due to the visitors arriving in their winter clothing in December.

9. Upon descent from the lift, the public circulates through the rest of the exhibitions before reascending into the entry building via escalator.



② Ramp descent

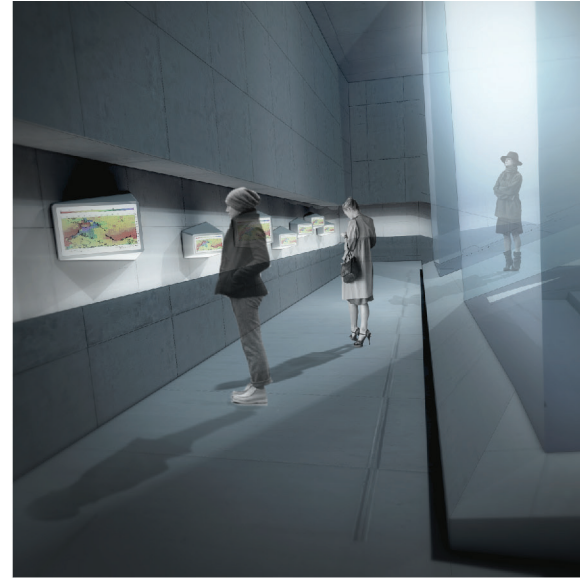

③ Continuous exhibition

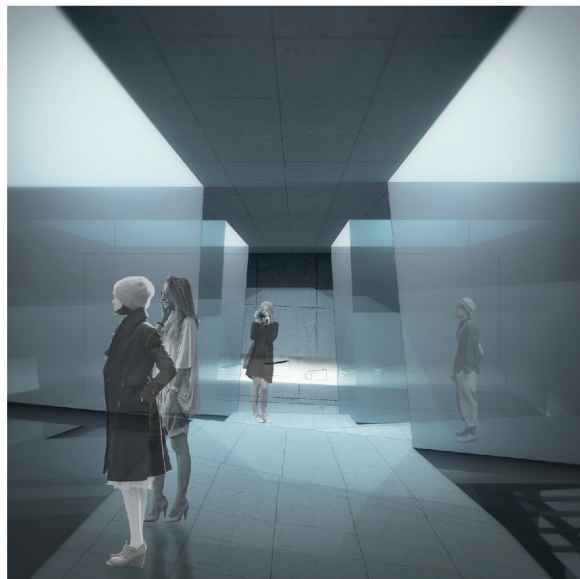

④ Procession between hydraulic lifts



⑤ Hydraulic lift platform



6 Ascent in lift shafts

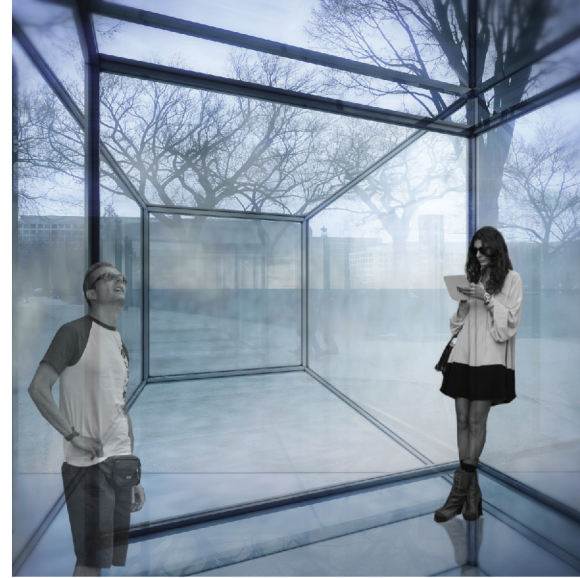

7 Views onto the Washington, D.C. Mall

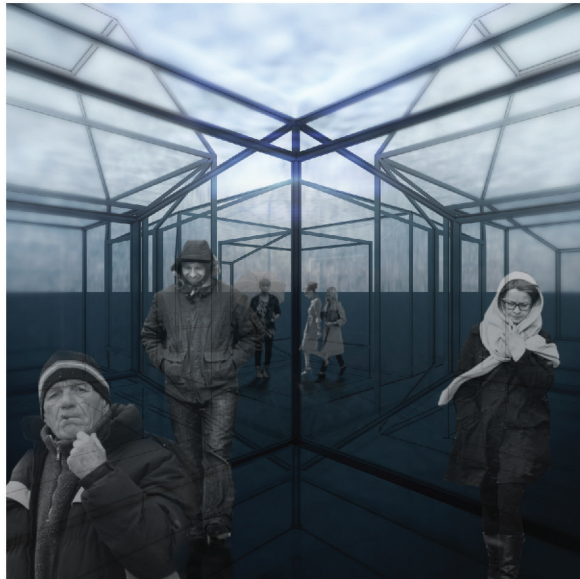

8 Views into adjacent chambers



9 Ascent into entry building across the garden

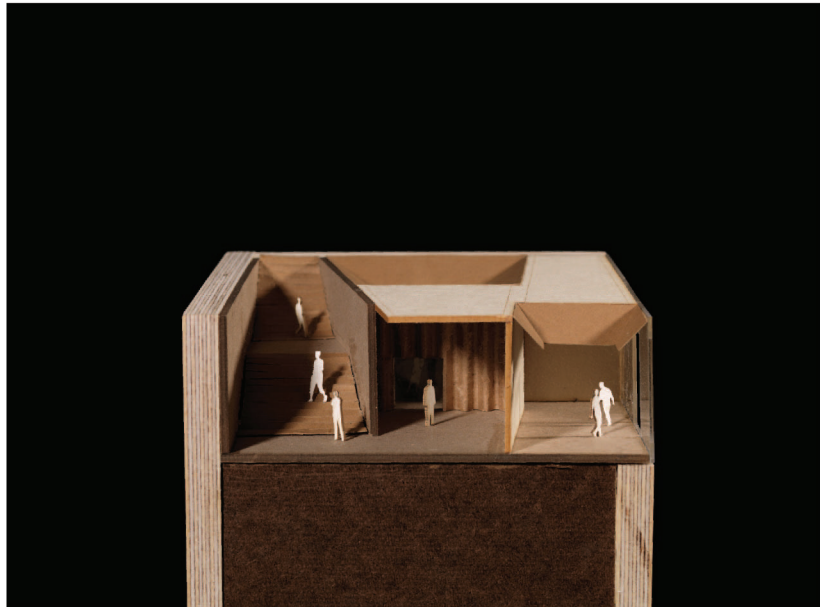

1/8" sectional museum entry model.

## MODELS

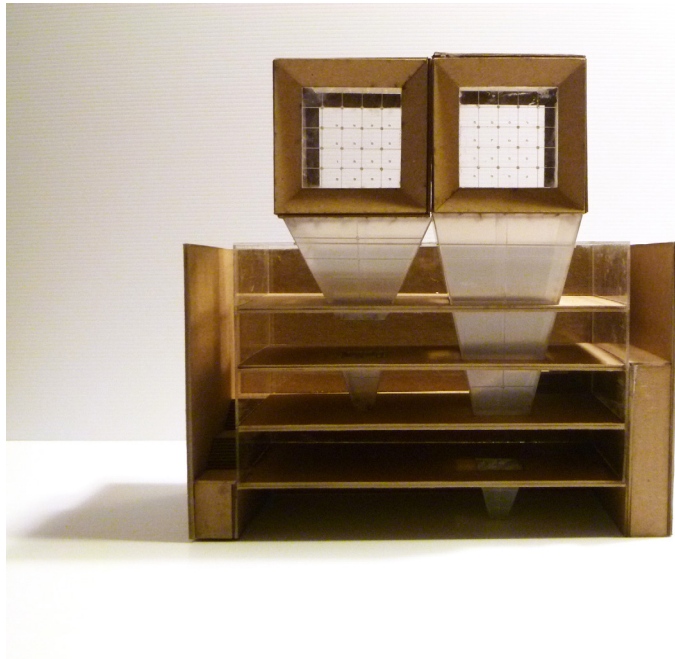

ABOVE: 1/16" initial study model.

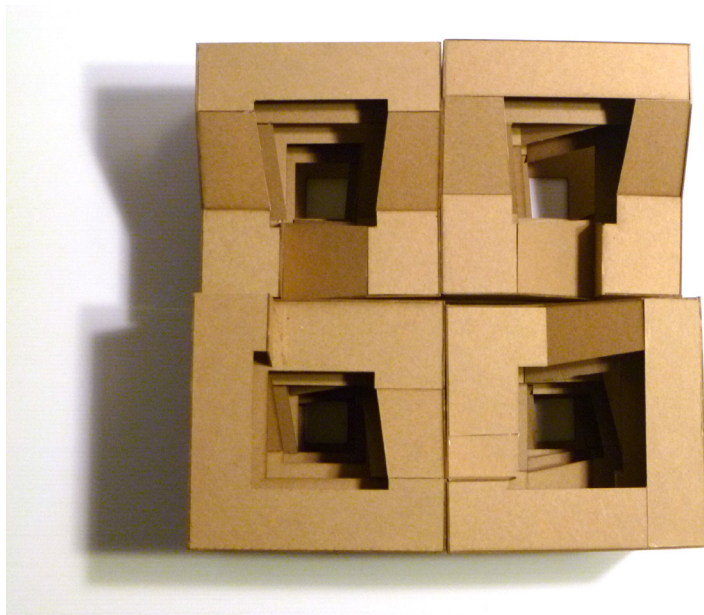

1/4" exhibition ramp study models.

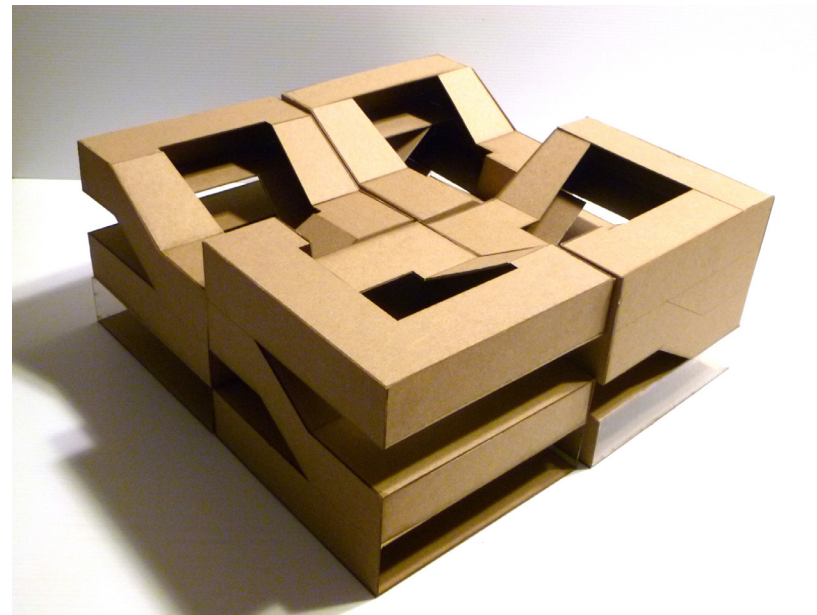



LEFT: 1/8" sectional museum entry model, RIGHT: 1/8" sectional exhibition and weather chambers model.



1/8" sectional exhibition and weather chambers model.



Elevator shafts and floor plates.



1/4" sectional model of one exhibition sequence.

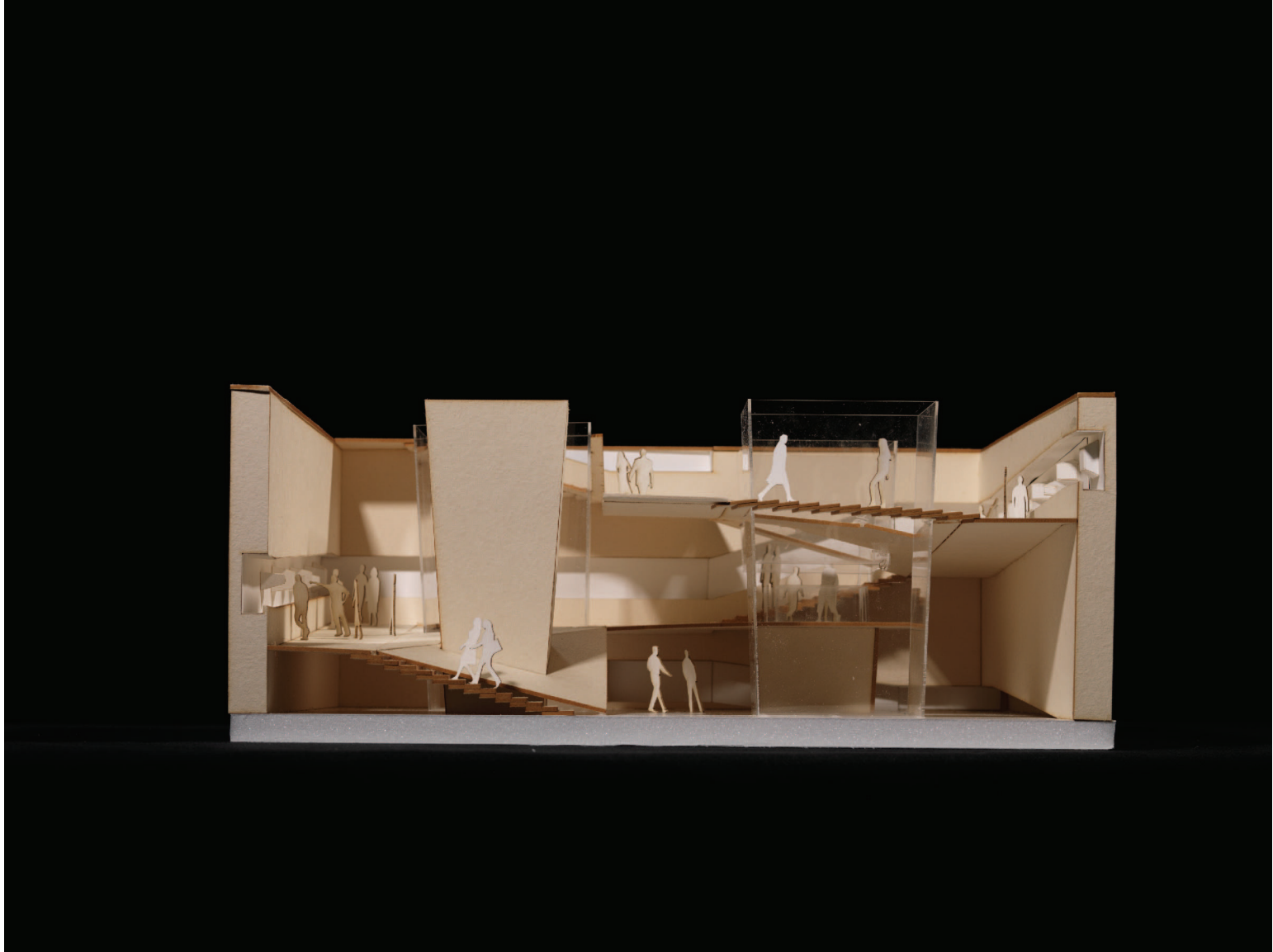

1/4" model sectional view.



ABOVE: Hydraulic lift platform.



TOP RIGHT: Enlarged ramped exhibition condition.  
BOTTOM RIGHT: Angled LCD screens embedded within the wall thickness.

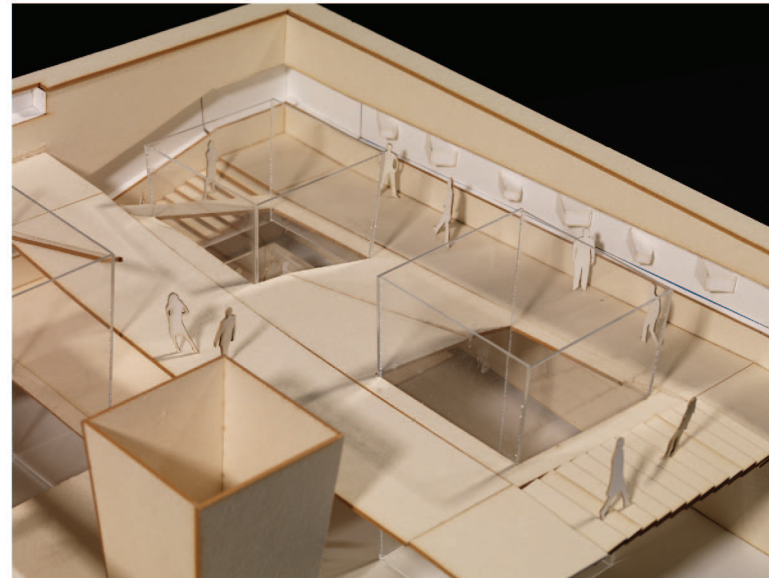

## **APPENDIX**



## PRECEDENTS

Architects and artists alike have pushed the limits of the influence of atmosphere and the interior versus the exterior in their work. More recently in architectural discourse, architects have sought to move beyond the fascination with technology and atmosphere as formal experimentation. In a conversation between Doug Aitken and Francois Perrin, Perrin says that “Air Architecture” needs to move beyond the period of formal experimentation into what is social and political. “The materials would be sounds, lights, gas, odors, etc. Things you can barely see, not ones you can grab. Through these elements you create new spaces, which is not an architecture as we know it, but more of an environment, an atmosphere.”<sup>23</sup>

The precedents in this section explore atmosphere in ways that free it from its monolithic scale and often singular treatment as a static object.

LEFT: Humid and dusty chambers in the middle of a D.C. winter.

---

23 Peter Noever and Francois Perrin, Yves Klein: Air Architecture (Los Angeles, CA: MAK Center for Art and Architecture: 2004), 135.

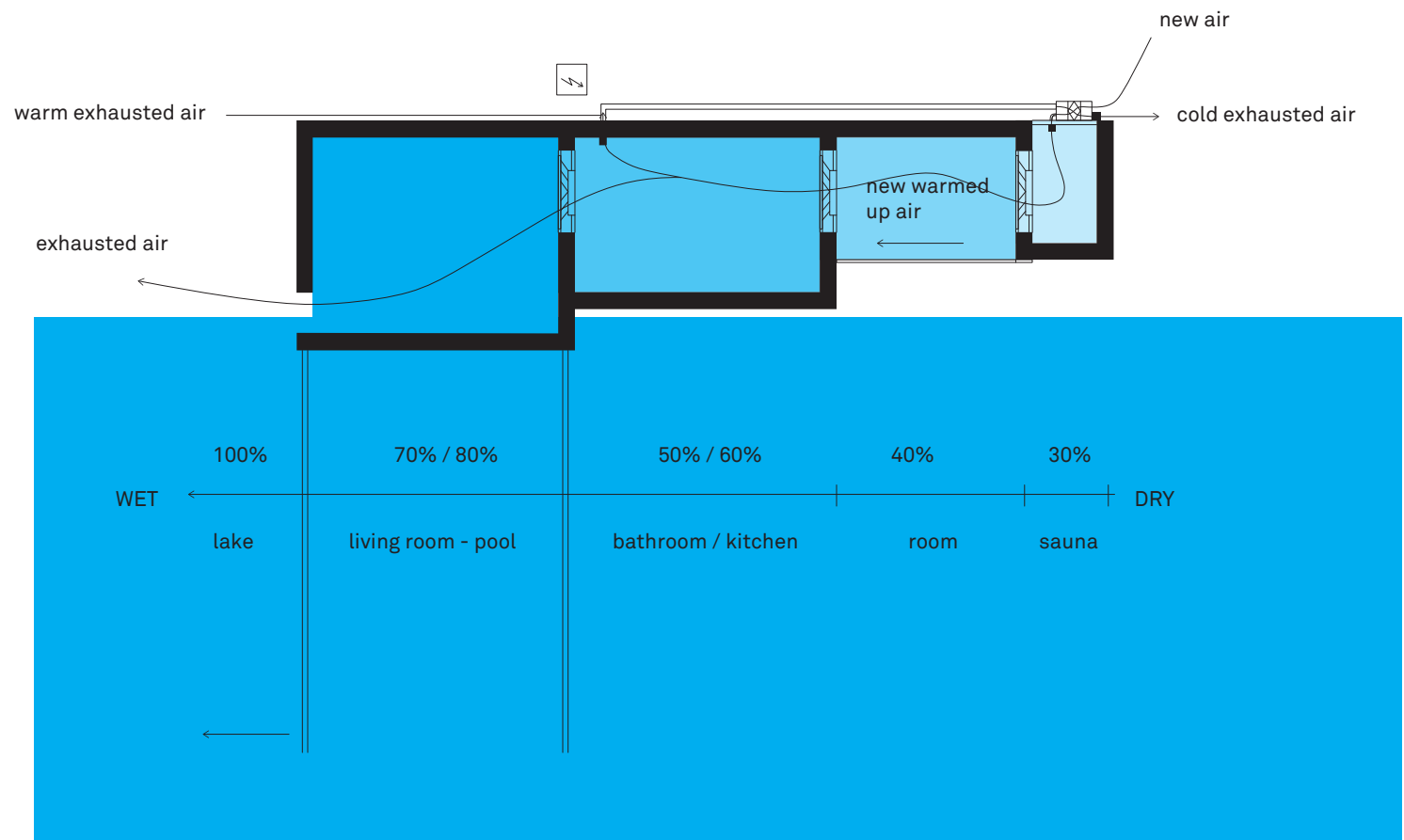

Mollier House  
 Vassiviere en Limousin, France (2005)  
 Philippe Rahm architects

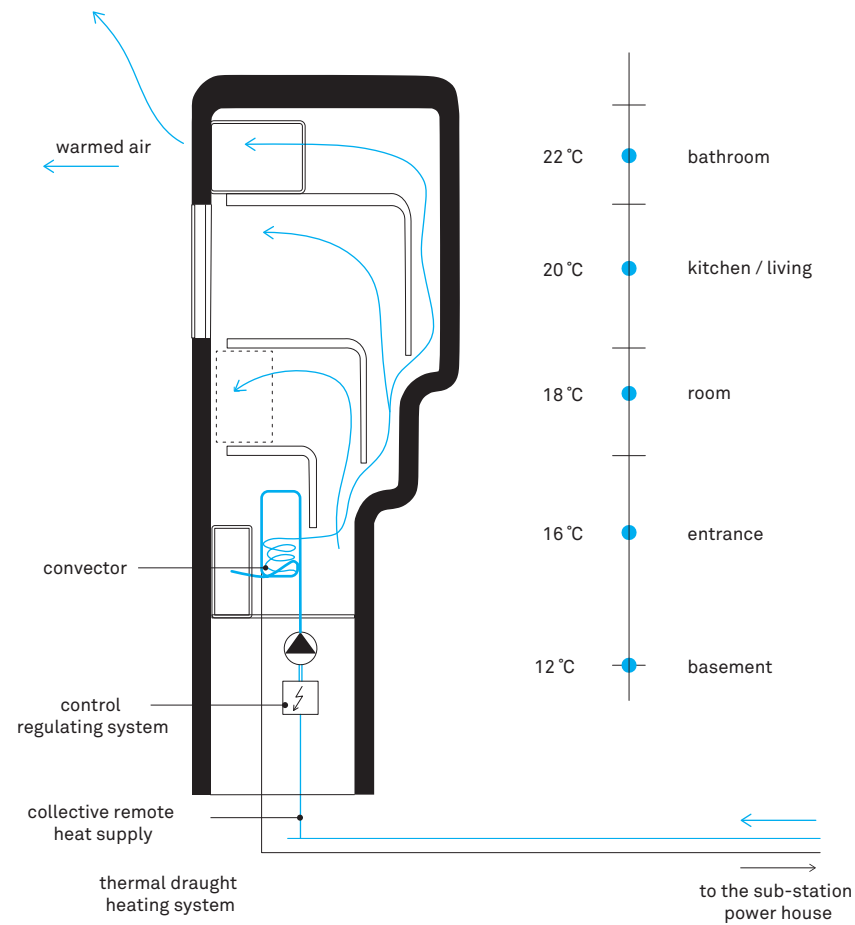

Archimedes House  
 Vassiviere en Limousin, France (2005)  
 Philippe Rahm architects

### Atmosphere as organization

The work of Philippe Rahm examines how climates and our body's physiological processes can move beyond the one-temperature-fits-all nature of our air-conditioned environments to restructure our daily lives.

In the Mollier House, Rahm proposes shaping space in relation to the water vapor humans emit during their daily activities within the domestic sphere. "Space becomes electromagnetic, chemical, sensorial and atmospheric with thermal, olfactory and coetaneous dimensions within which we are immersed."<sup>24</sup> The house stratifies the levels of humidity within the house to create spaces that are more or less dry or humid, giving its occupants the flexibility to choose their own comfort level.

In the Archimedes House, Rahm takes the chimney effect, or the simple fact that heat rises, to re-code the domestic sphere both formally and from an energy consumption standpoint. Understanding that the human body can experience a range of comfort and energy optimizations can allow the body to play a greater role in mediating its own atmospheres.

<sup>24</sup> Sean Lally, "Meteorological Architecture," *Architectural Design: Energies New Boundaries*, 79.3 (May/June 2009): 32.

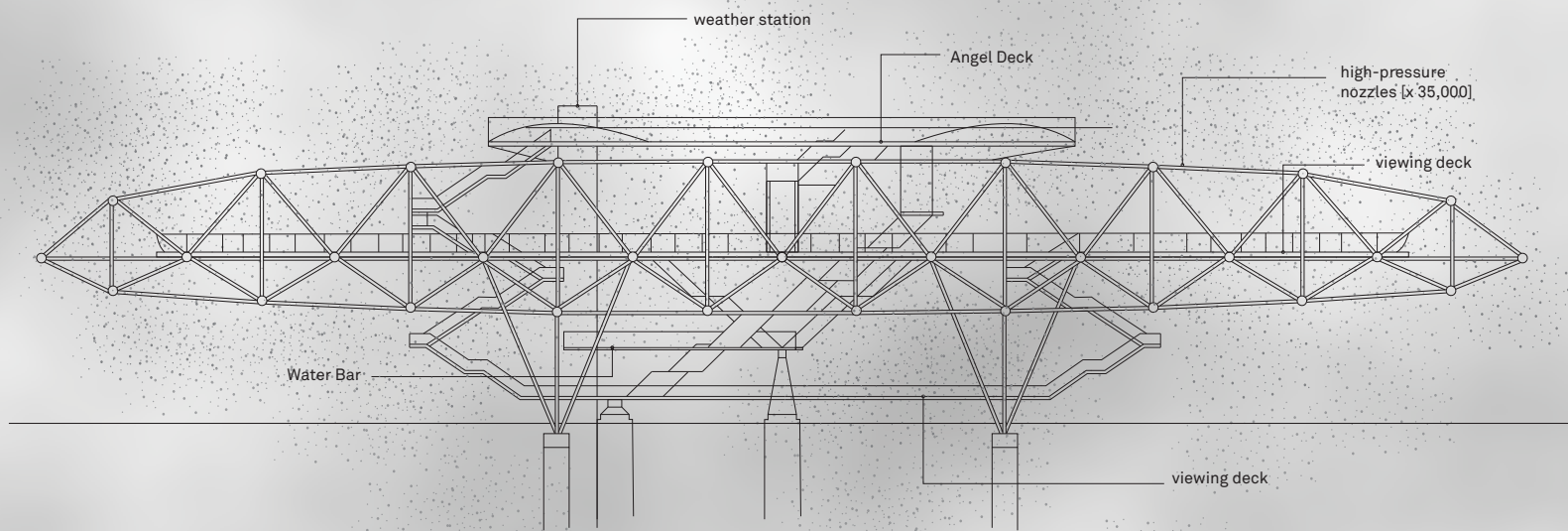

Blur Building  
Yverdon-les-Bains, Switzerland (2002)  
Diller Scofidio + Renfro



See the generated fog from several viewing decks and from the bridgeway to the pavillion. Visualize other visitors through the provided smart rain coats and have your vision blurred.



Hear the sound of filtered lake water being shot out as mist from 13,000 nozzles.



Smell the wetness of the mist and surrounding Lake Neuchatel.



Taste the variety of municipal, commercial, and glacial waters at the Angel Bar.



Feel the moisture from the mist.

## Atmosphere as material

Diller Scofidio & Renfro's Blur Building in Switzerland utilizes atmosphere as the project's building material (or immaterial). A weather station controls high-pressure nozzles which control a fog in response to shifting climatic conditions. The project suggests how the dynamic nature of atmospheric conditions can be employed to create unique sensorial experiences. As the visitor enters the "building", there is a visual white-out from walking into the fog. Visitors hear the pulsating nozzles and feel the spray of architectural material as they move through the viewing decks. The building material can even be imbibed at the project's Water Bar. The project blurs the lines between architecture and atmosphere, letting the user walk through the building envelope and literally inhabit the air.

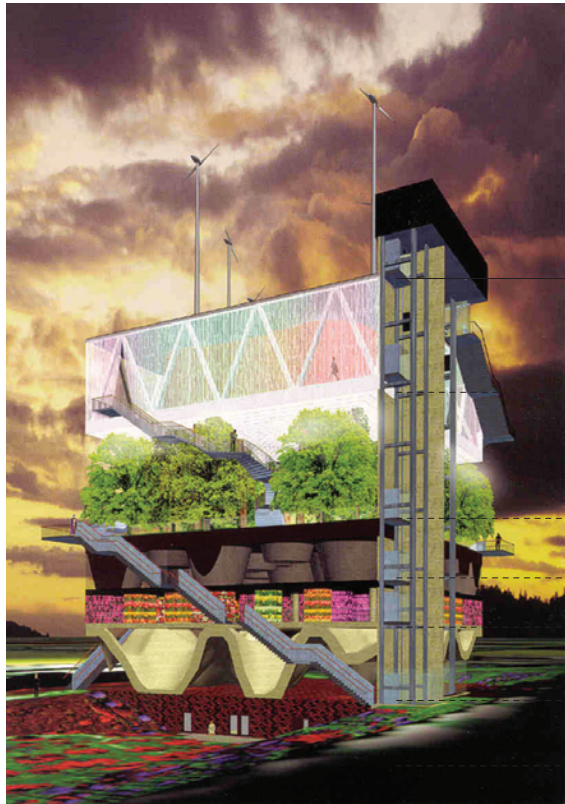

Dutch Pavilion  
 Hannover, Germany (2000)  
 MVRDV

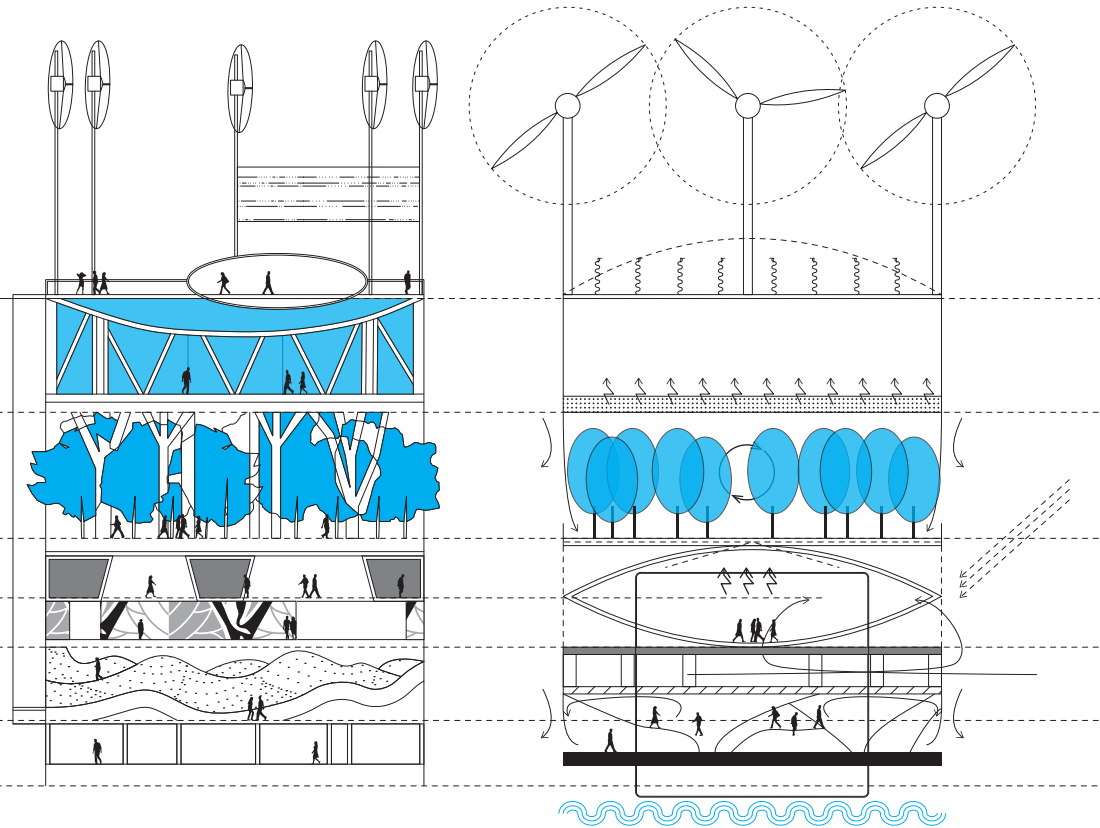

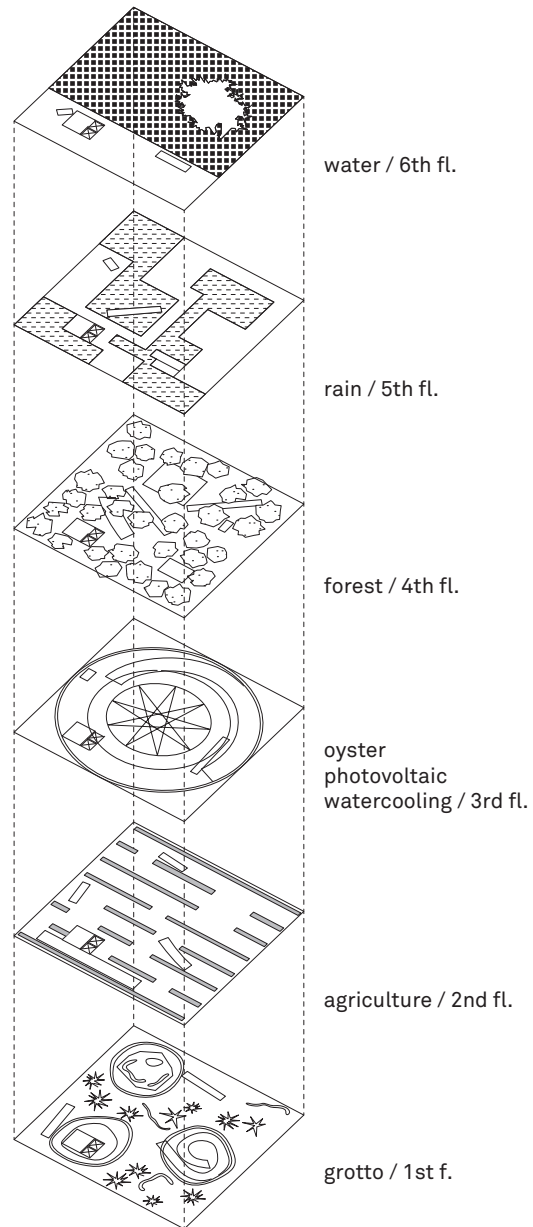

## Atmosphere as spectacle

MVRDV's Dutch Pavilion acts as a kind of ecological sensorium, showcasing how one atmospheric condition can be catalogued with another. It is an assemblage of natural and artificial platforms from a formal perspective produced for the World Exposition Expo in 2000. There are six overlapping concepts of landscape, creating a stacked ecological system meant to be self-sufficient with its own power and water systems.

The project used only a tenth of its allocated plot, commenting on pollution and congestion within European cities. The Dutch Pavilion functioned more successfully as a cash generator than as a self-sufficient ecosystem MVRDV had originally diagrammed in early conceptual drawings. Costing about 35 million euros to build, the project generated close to 350 million euros for the Dutch economy, capitalizing on the spectacle of the artificial.

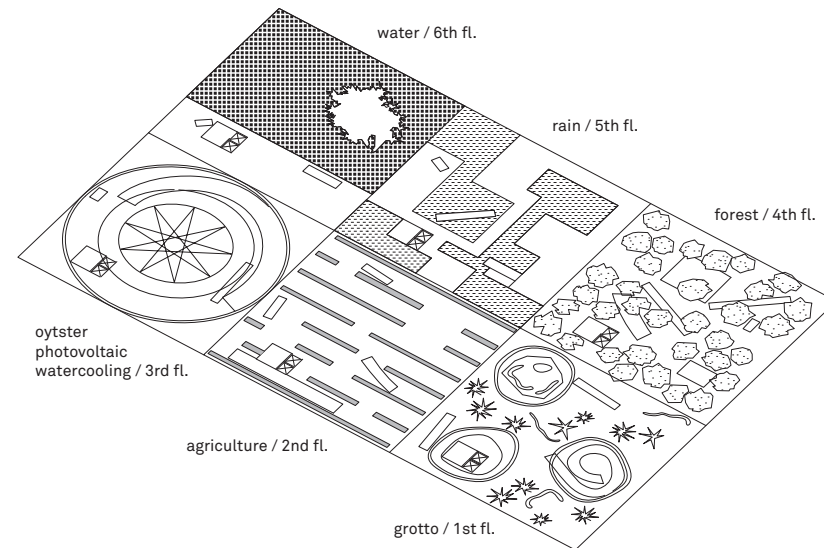

Biosphere 2  
Oracle, Arizona (1987-2007)  
Space Biosphere Ventures

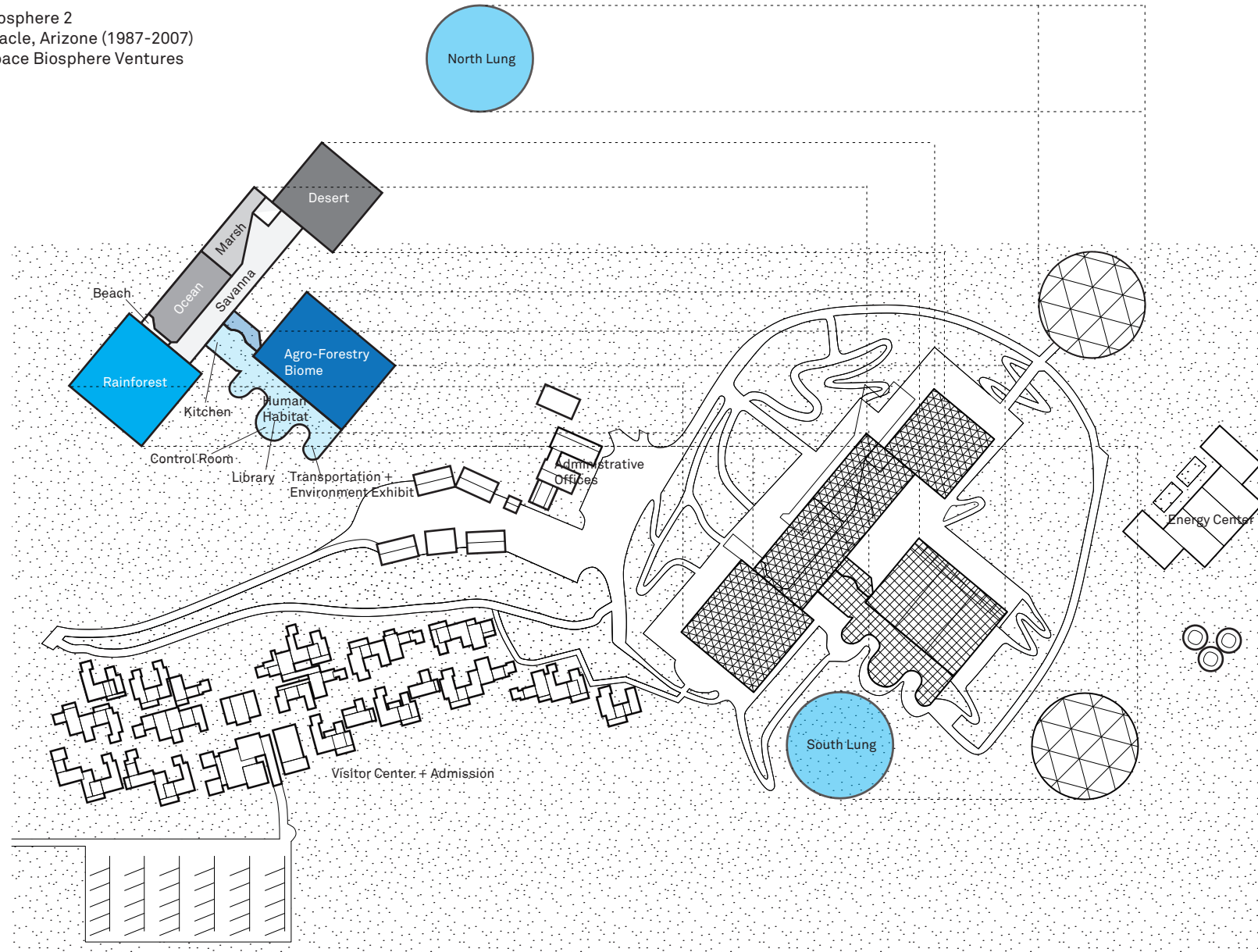

### Atmospheric containment

Biosphere 2, created by Space Biosphere Ventures, sought to create a balance between biosphere and technosphere with eight humans, 3800 other species and seven biomes for two years. In its effort to create a harmonious, self-sufficient ecosystem, Biosphere 2 was a failure. Designed to be the world's most airtight building with less than 10% leakage per year (less than the rate of a space shuttle about 1000 times the commercial building industry standard), Biosphere 2's stability was premised on keeping the exterior atmosphere out while still remaining in Earth's atmosphere. As a closed system, the facility's outer structure formed a series of defining boundaries which had to be constantly monitored and repaired to maintain total separation from the external environment. Covering 1.27 hectares of the Sonoran Desert in Oracle, Arizona, the project cost over \$200 million during its construction and maintenance from 1985-2007.

The project implemented and tested a series of boundary conditions with the goal of maintaining its materially closed environment. The facade featured a multi-hinge node-less space frame, triangulated to minimize thermal deformation with vacuum tested, double-caulked glass panes. The panes of glass were caulked in two different colors (grey and white) to ensure that each pane had been caulked twice. The interior atmosphere was circulated continuously throughout the facility; however, the wilderness biomes had to be separated from the agriculture and habitat biomes. This was achieved through the use of variable volume chambers, or "lungs" which allowed for thermal contraction and expansion of air within the sealed structure and compensated for barometric pressure changes, thus

preventing leakages within the facility.<sup>25</sup>

Below ground, the facility was sealed with three millimeter stainless steel panel-lined concrete slabs between two meters of earth. In addition, sniffer tunnels were embedded under each welding seam to compare the outside air with that of Biosphere 2. All flat floor areas were flooded with water, and compressed air was forced into the sniffer lines beneath to identify leaks through the appearance of bubbles.

Despite the project's efforts to maintain its delicate air quality, ants eventually penetrated the silicon seals, uniting interior and exterior conditions. A stowaway cockroach and morning glories led to other natural infestations. "Due to the unforeseen oxygen absorption by the raw concrete, oxygen plummeted from 20.9% of the atmosphere to 14% (equivalent to respiration above 10,000 feet in six months). A measured amount of air had to be added for survival."<sup>26</sup> The inhabitants eventually went hungry, lost weight and reported headaches and exhaustion from caffeine withdrawals, depression and constant work.

While Biosphere 3 may have failed as a self-sustaining commune, it demonstrated nature's presence as a battlefield where biomes and species had to compete for a finite amount of resources.

25 Bernd Zabel et al., "Construction and engineering of a created environment: Overview of the Biosphere 2 closed system," *Ecological Engineering* 13 (1999): 43.

26 Janette Kim and Erik Carver, "Crisis in Crisis: Biosphere 2's Contested Ecologies," *Volume 20* (2009): 30.

Biosphere 2 boundary conditions

Caulking detail for glass panes

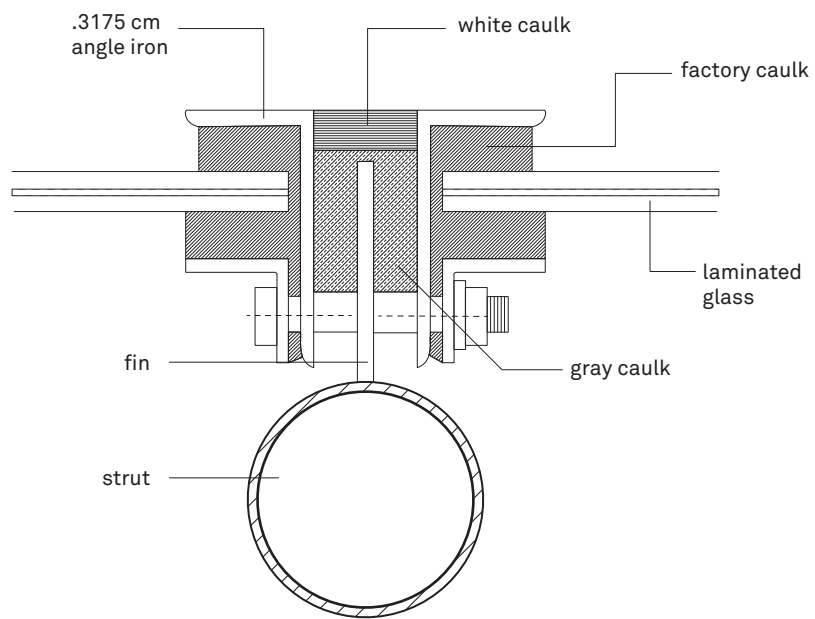

External sniffer tunnel

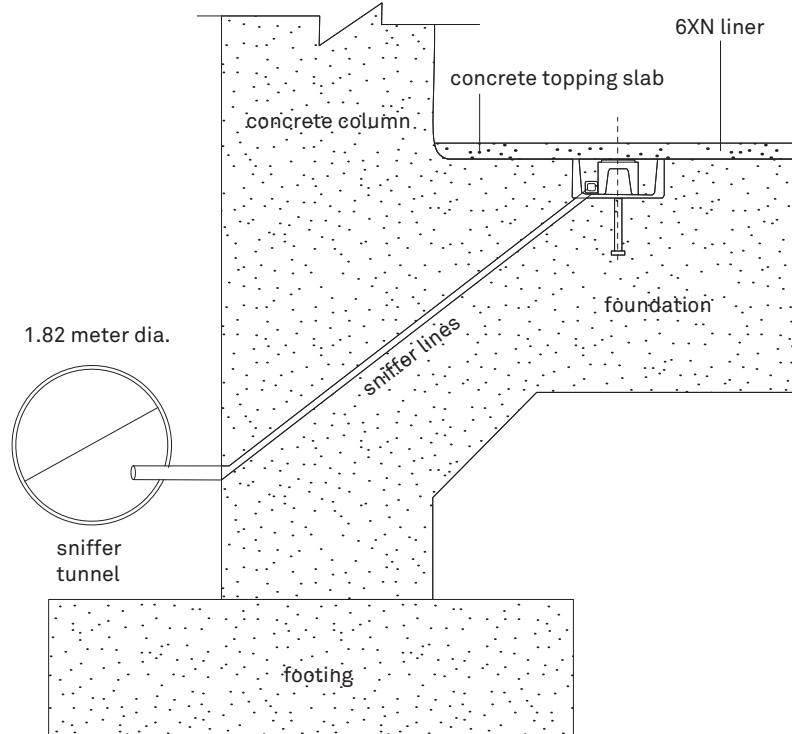

Test module for lung expansion tank

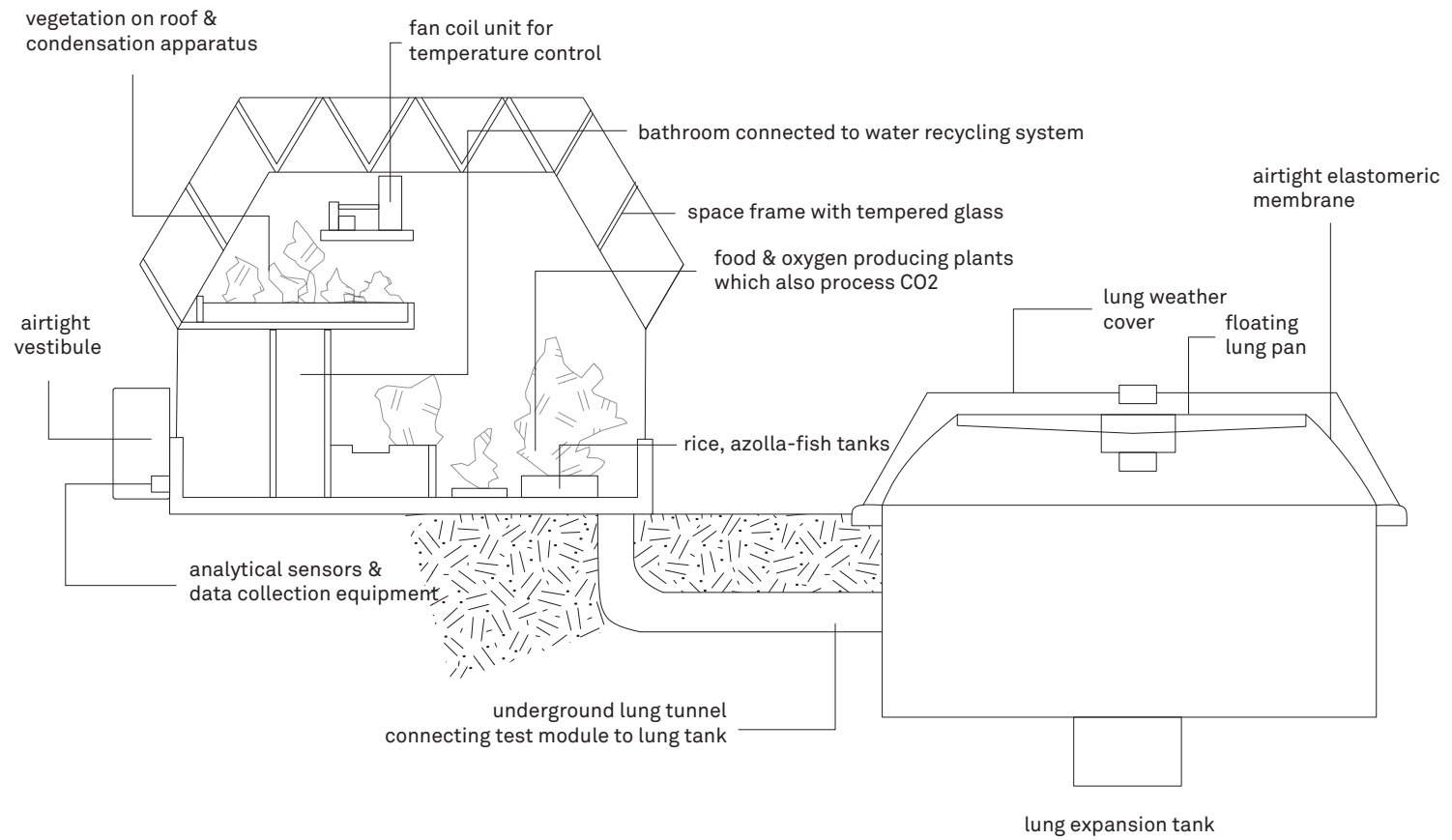

1.



2.

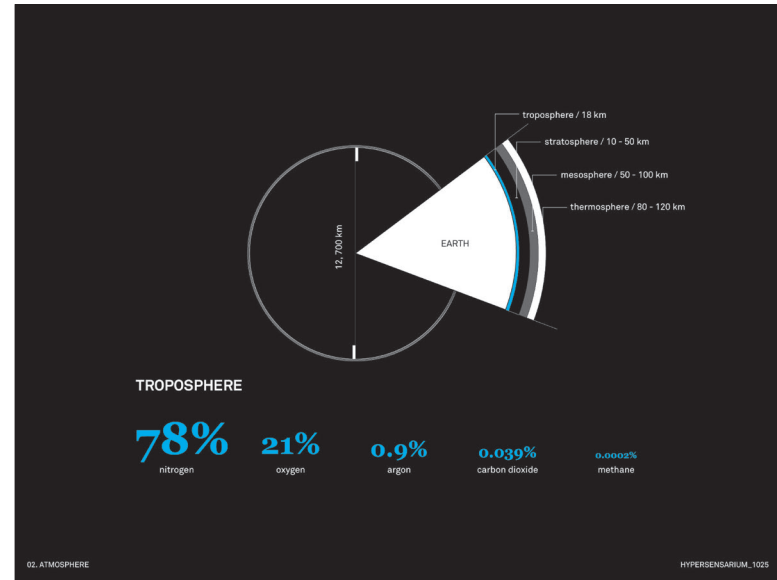

3.

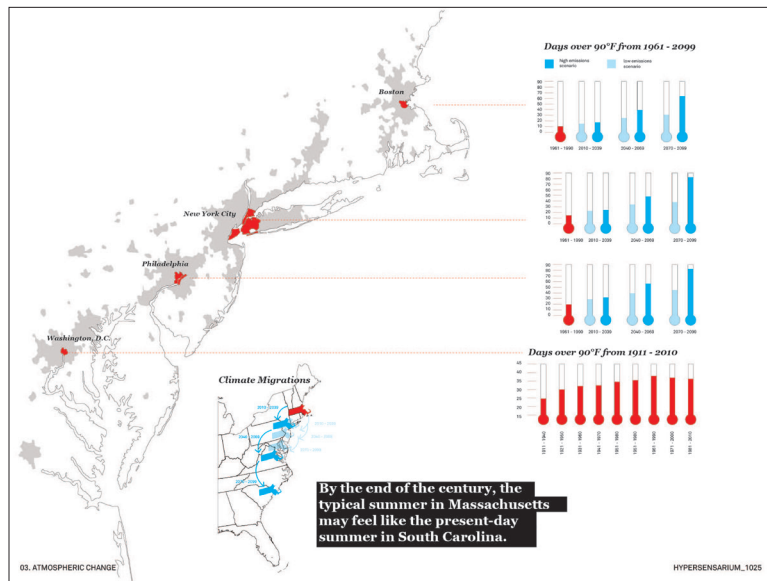

4.

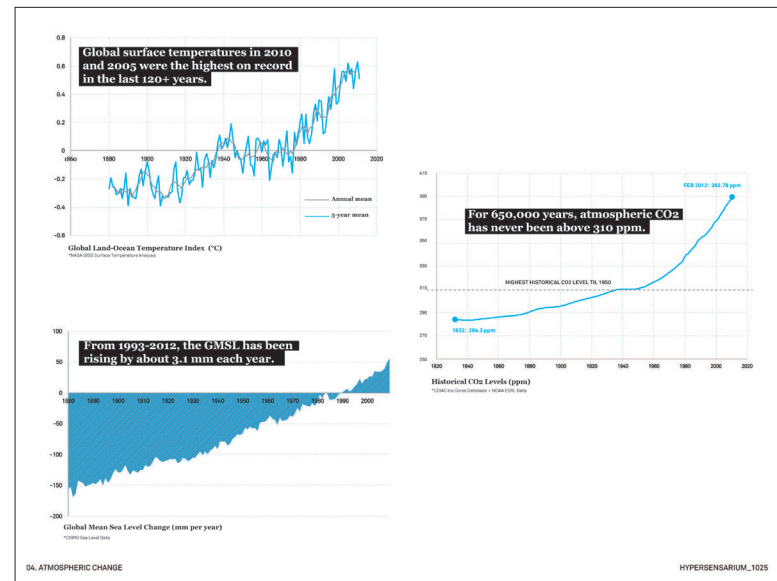

## PECHA KUCHA

1. Architects have long negotiated the relationship between our exterior climates and interior environments. HYPERsensarium proposes a tangible interface of atmosphere for the public through an archive of projected atmospheres.
2. Architecture acts as the physical boundary between the human body and natural elements. However, the thin layer of gas only 18 kilometers thick over our atmosphere is the conduit for everything the human sensorium perceives.
3. Our industrial activities overlook one of the largest shared common resources in the world when we think of air as a void. Historical data and climate modeling technologies show increasingly hot summers and by the end of the century, a typical summer in Massachusetts may feel like the present-day summer in South Carolina.
4. Despite the copious amounts of scientific data showing rising surface temperatures, increasing carbon dioxide and rising sea levels, these strings of data from the EPA, IPCC, NOAA, etc., are static presentations.

5.

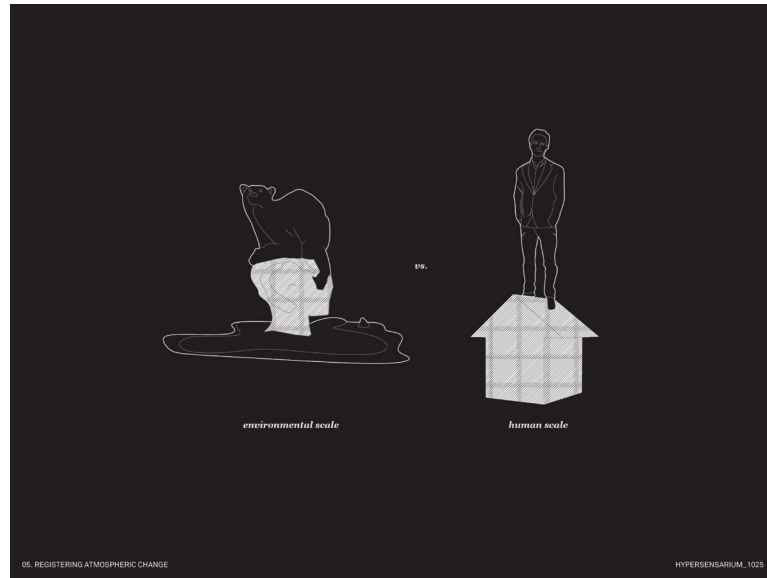

6.

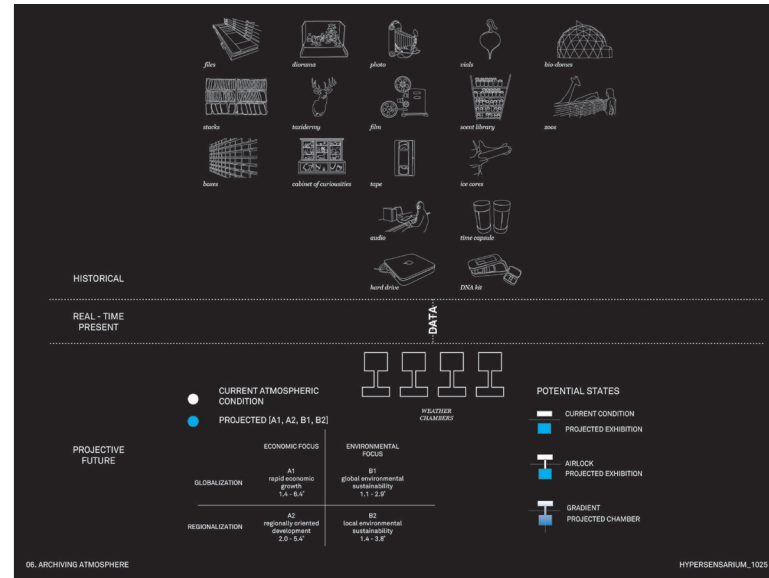

7.

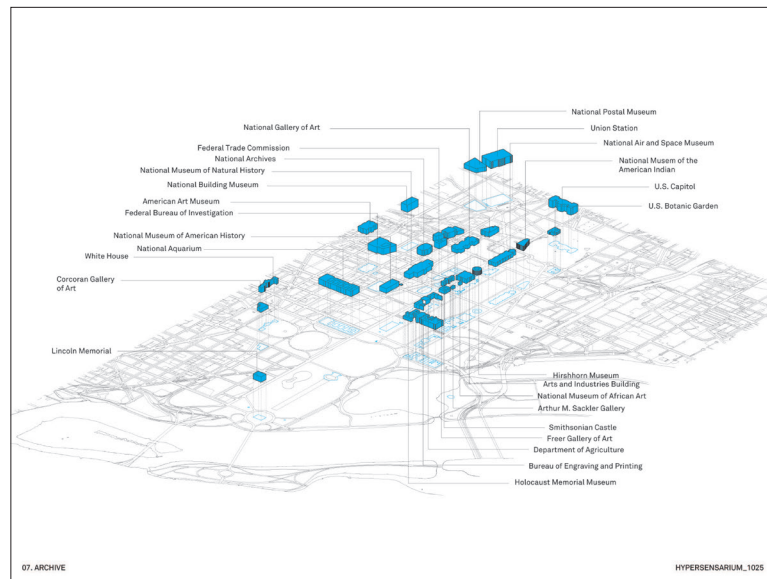

8.

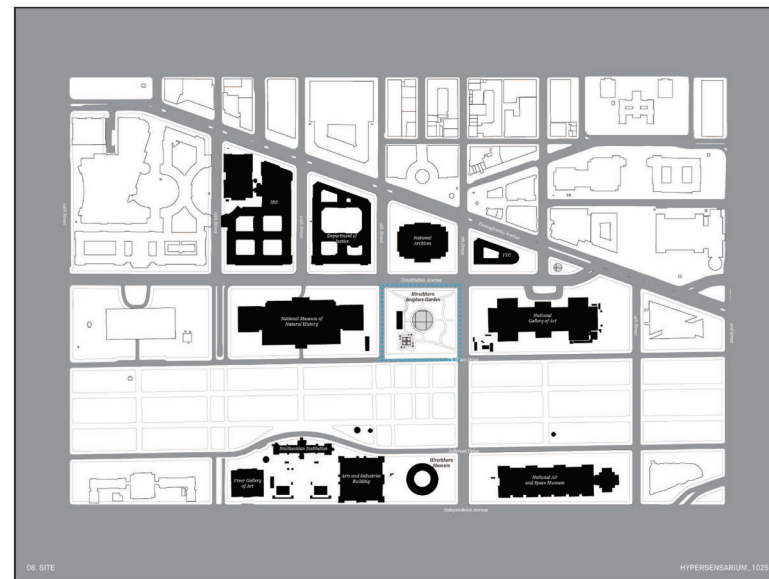

5. Issues with public understanding and action is one of scale. Environmental issues occur on broad scales of time, space and complexity considered too expansive and distant for our attention.

6. HYPERsensarium proposes a museum which distills the complexity of this dormant data by using weather projection technologies to create weather chambers which make the future immediately tangible to the public. While most archives are about collecting and accumulating, HYPERsensarium asks that we use the archive to look forward, using future economic and energy scenarios, rather than just back. In order to achieve a heightened differential between environments, the museum contains just four projected future scenarios.

7. The Washington, D.C. Mall is currently an assemblage of institutes embodying what is important to our cultural psyche. While the archive is about preservation and decay, HYPERsensarium seeks to show the didactic potentials of its archived weathers.

8. Sited between the National Gallery of Art, Natural History Museum, and National Archives, in HYPERsensarium's chambers, the forecasted weathers become the objects on display.

9.

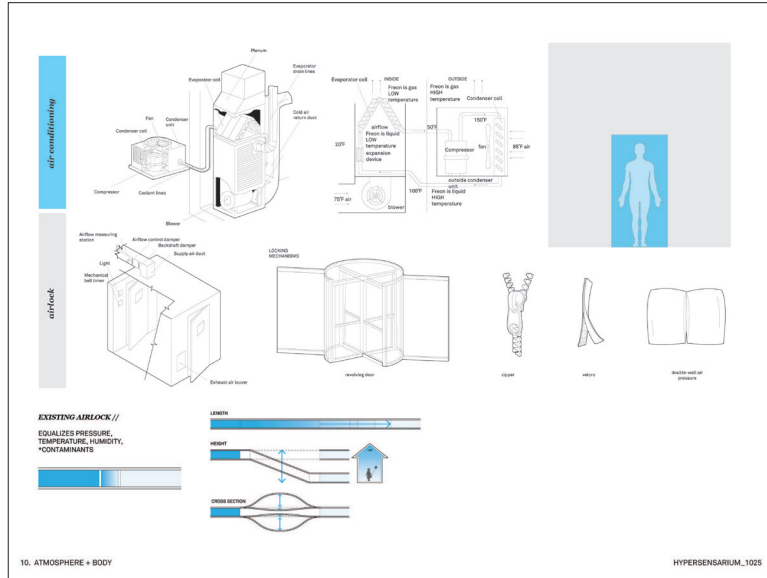

10.

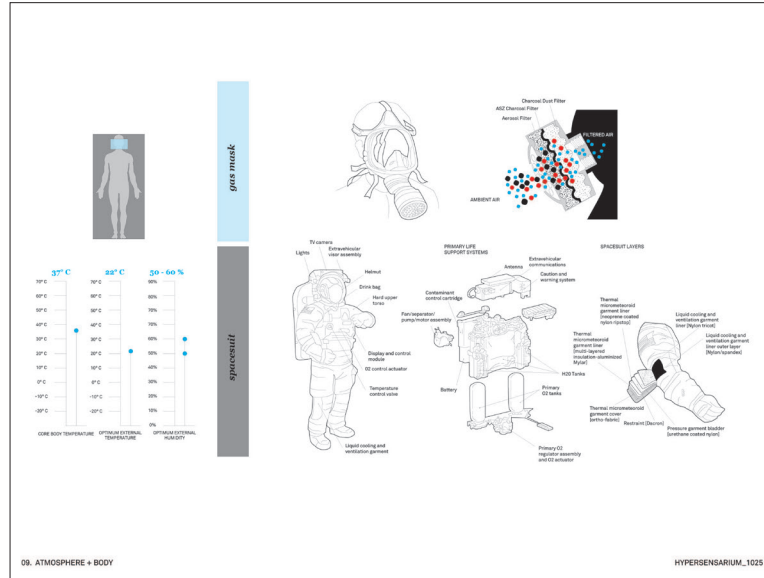

11.



12.

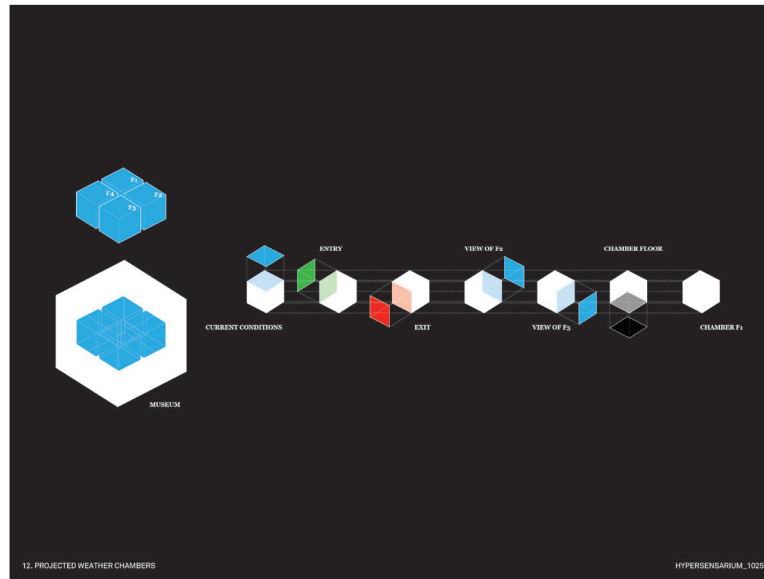

96

9. In designing a system for creating these projective chambers, existing methods for atmospheric augmentation were analyzed. The gas mask and spacesuit demonstrated the limits of atmospheric content necessarily for our survival.

10. At a larger scale, HVAC systems and the airlock have provided the tectonic tools we use to augment our climates. The project's strategy is to reinvent the existing airlock as it acts as the negotiator between exterior, museum interior and HYPERsensarium's weather chambers.

11. The fermentation lock suggest the potential for dividing and delimiting air through its chambers. They allow for carbon dioxide to escape while preventing oxygen from entering.

12. The chambers' design have been broken down into providing a means for entry and exit, a way to see and feel current conditions and providing a view of other contained atmospheres.

13.

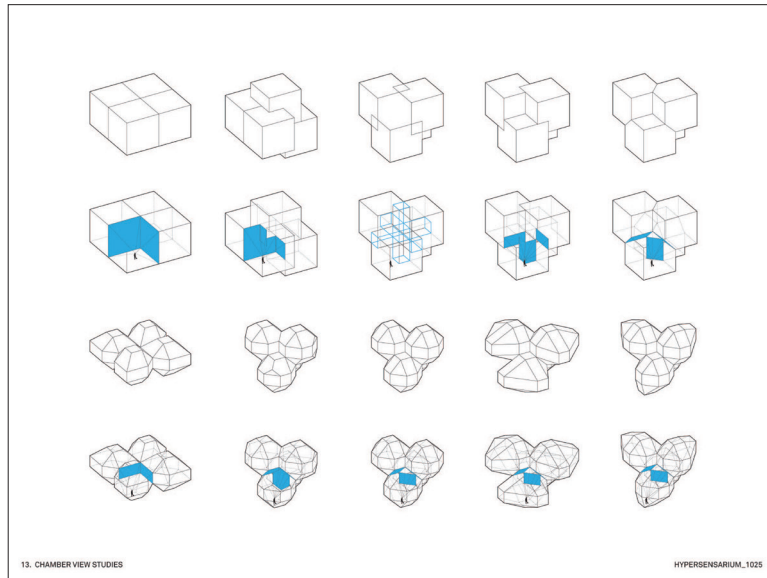

14.

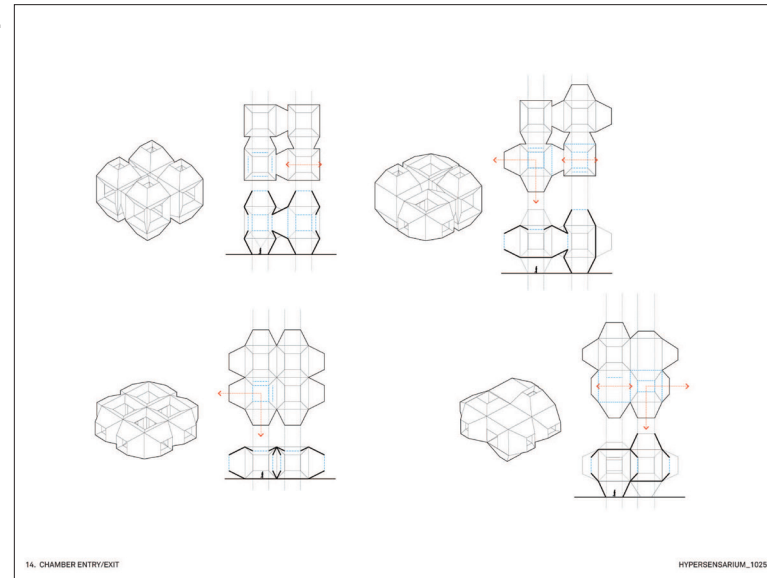

15.

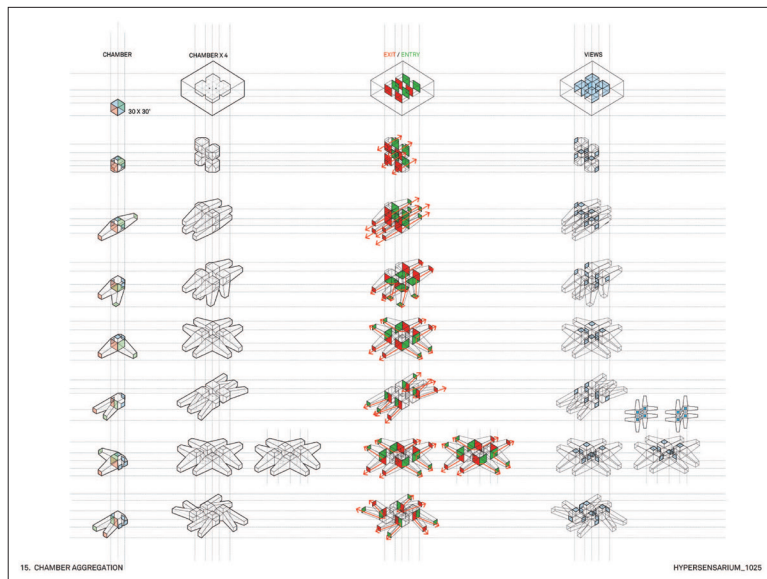

16.

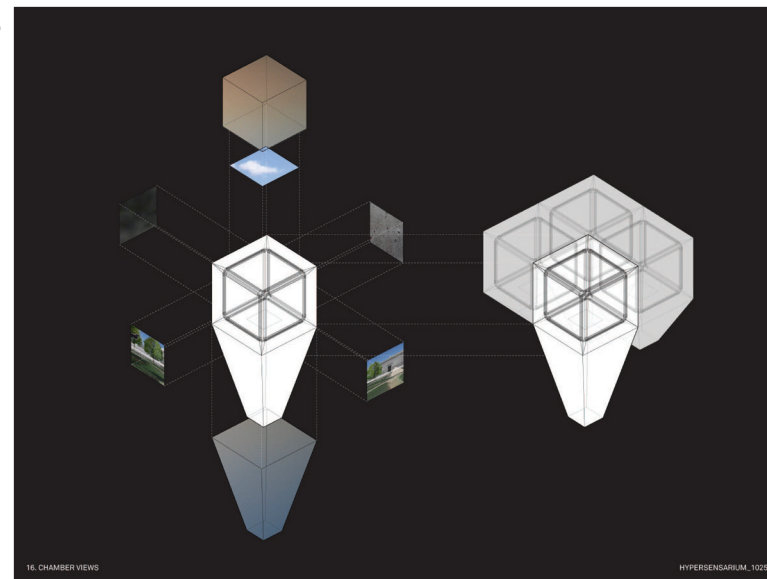

13. With the forecasted weather on display, initial geometric studies investigated how one chamber could be visualized but not physically experienced, thereby encouraging visitors to investigate alternative entries into the chambers.

14. Other configurations examined how the four projected weathers could be accessed both from the ground and in a potential sequence from one chamber to the next.

15. A composite of chamber aggregation studies suggests how different configuration logics can in turn influence both access and vantage points.

16. HYPERsensarium's chambers take real-time weather data and morph its atmosphere to provide visitors with a simulated experience of how the day's weather could change in the future, thereby compressing time and showcasing impact.

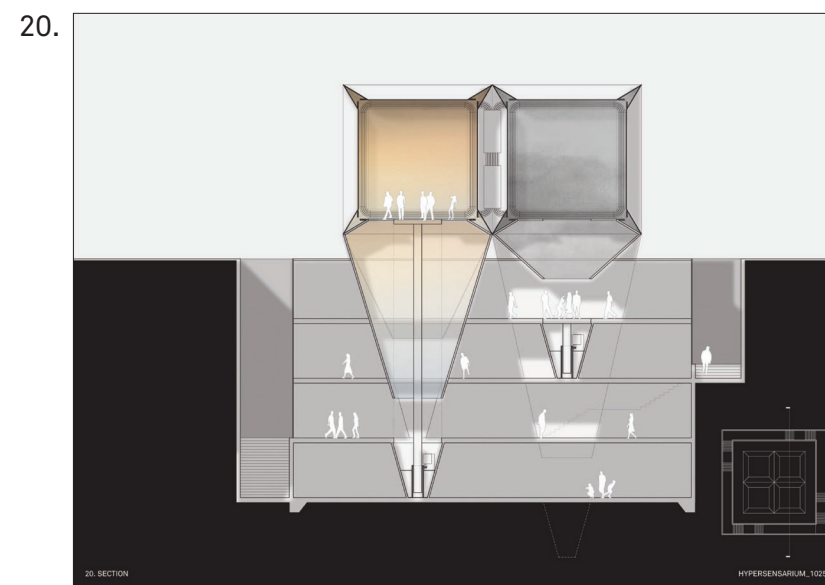
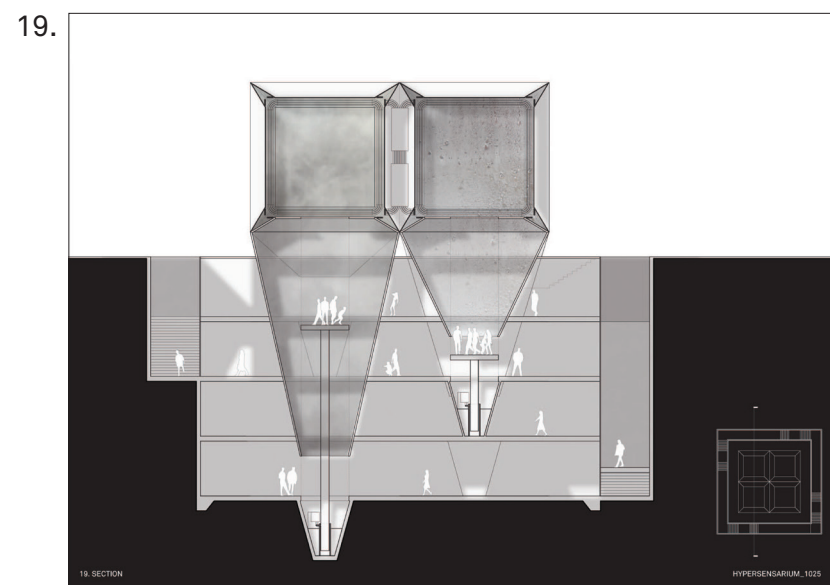
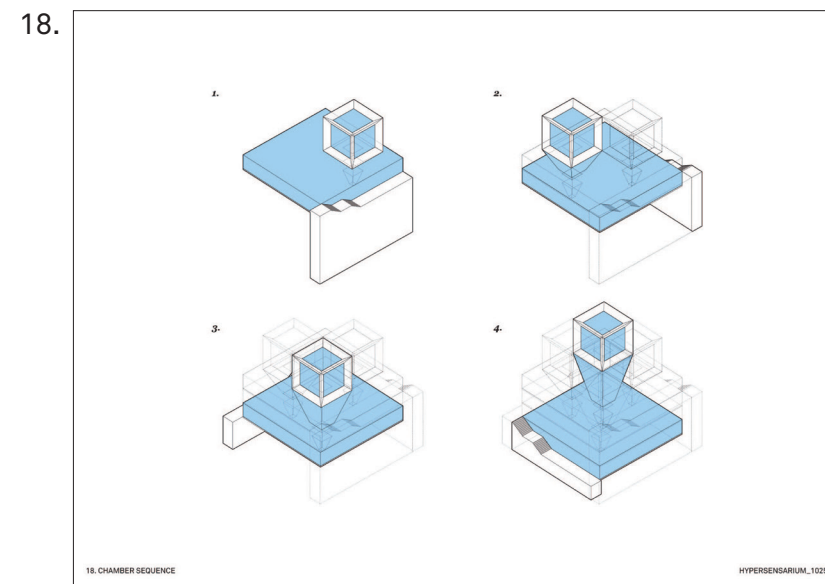

17. The environments created in the chambers are shaped entirely by the conditions on the exterior, thus becoming an architecture driven by exterior conditions. Excavating into the site, HYPERsensarium's chambers float above ground masking the museum's subterranean existence.

18. Each future chamber is locked with its own exhibition floor, thus forcing visitors to return outside to experience the current atmosphere before passing into the next future.

19. The mechanisms for the extruded airlock into the chambers are hydraulic lifts which pass through extruded glass shafts. Technically I am still trying to determine whether this scheme can have the effect I want to achieve.

20. While the airlock exists at the top of each chamber, the glass shaft acts as a semi-open chamber allowing visitors on all floors to view the changing gradients of temperature and humidity. The museum acts as an architecture dependent on conditions of its site, registering atmospheric change before providing a new atmosphere for public consumption.



Final Review



Final Review

**THESIS DEFENSE**

Thursday, December 20, 2012  
MIT Media Lab  
Building E14, 6th Floor

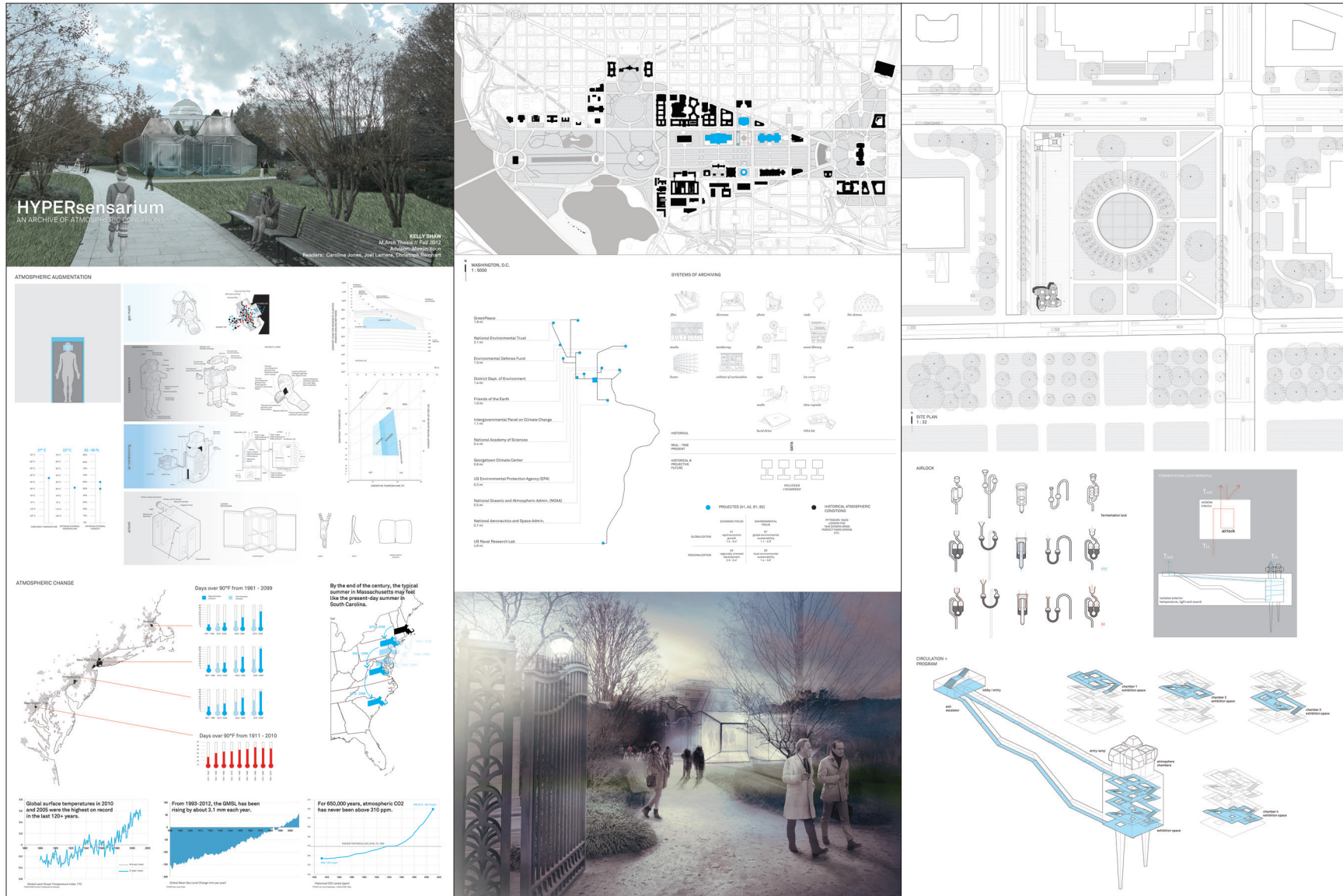

Final Boards 1-3

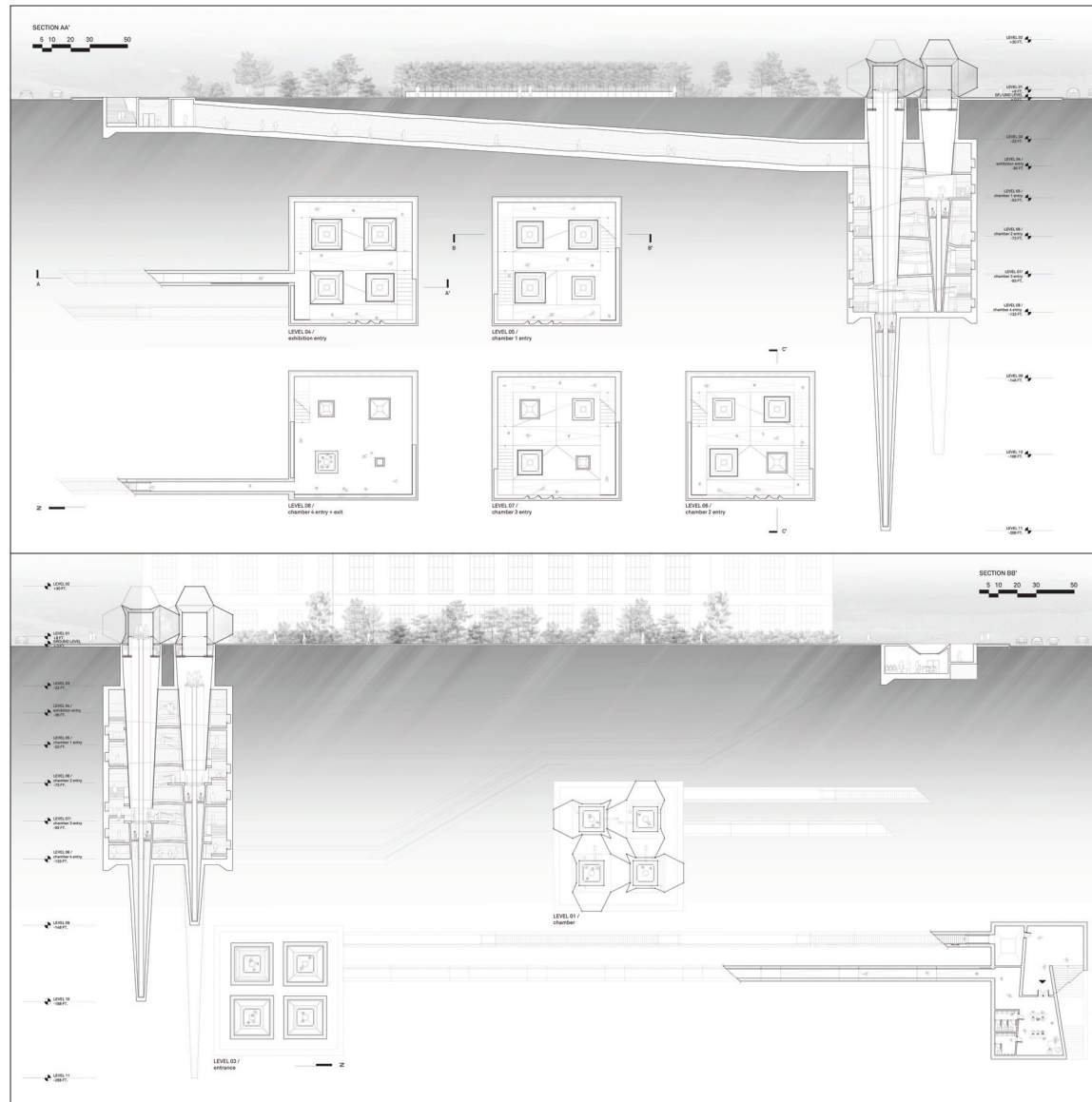

Final Boards 4-5



VISITING HYPERSENSARIUM

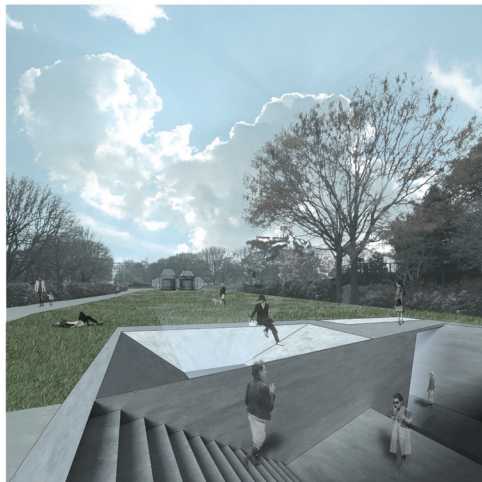

1 ENTRANCE

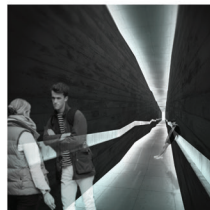

2 RAMP DESCENT

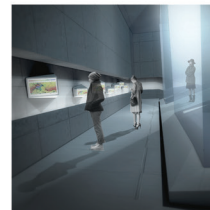

3 CONTINUOUS EXHIBITION

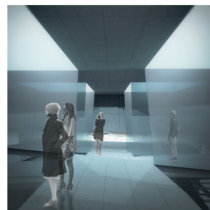

4 PROCESSION BETWEEN HYDRAULIC LIFT SHAFTS



5 HYDRAULIC LIFT PLATFORM



6 ASCENT IN LIFT SHAFTS

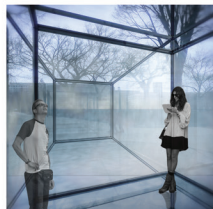

7 VIEWS ONTO WASHINGTON, D.C. MALL



8 VIEWS INTO ADJACENT CHAMBERS



9 ASCENT INTO ENTRY BUILDING

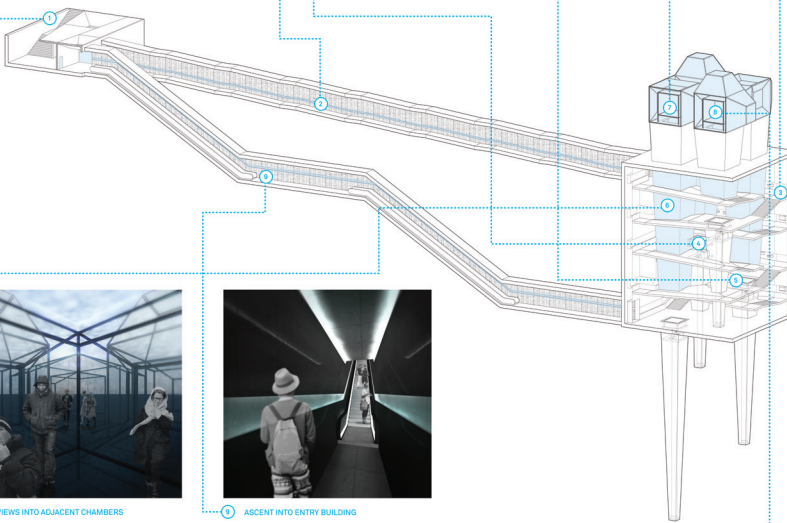



## BIBLIOGRAPHY

- Addington, Michelle. "Contingent Behaviours." Architectural Design: Energies. 79.3 (May/June 2009): 12-17.
- Adorno, Theodor W. "Valery Proust Museum." Prisms. Cambridge, MA: MIT Press, 1981.
- Banham, Reyner. Architecture of the Well-tempered Environment. Chicago: University of Chicago, 1984.
- Bartzak, Tomas. "Weather + Science." -arium: Weather + Architecture. Ostfildern, Germany: Hatje Cantz Verlag, 2010.
- Benjamin, Walter. "Unpacking My Library." Illuminations. New York: Schocken, 1969.
- Decosterd and Rahm. Distorsions. Orleans, France: HYX, 2005.
- Diller + Scofidio. Blur: the making of nothing. New York: Harry N. Abrams, 2002.
- Durandin, Benoit. Spoiled Climate. Basel: Birkhaus Architecture, 2000.
- Haraway, Donna J. "Teddy Bear Patriarchy: Taxidermy in the Garden of Eden." Social Text. 11(1984/85): 19-64.
- Holm, Erik and Leslie Scism. "Sandy's Insured-Loss Tab: Up to \$20 Billion." The Wall Street Journal. 2, Nov. 2012. <<http://online.wsj.com/article/SB1000142405297020>

4712904578092663774022062.html>.

Gissen, David. Subnature: Architecture's Other Environments. New York: Princeton Architectural Press, 2009.

Jarzombek, Mark. "Haacke's Condensation Cube: The Machine in the Box and the Travails of Architecture." Threshold 30: microcosms. (MIT Department of Architecture Summer 2005): 98-105.

Kim, Janette and Erik Carver. "Crisis in Crisis: Biosphere 2's Contested Ecologies." Volume. 20 (2009): 29-33.

Lally, Sean. "Meteorological Architecture." Architectural Design: Energies New Boundaries. 79.3 (May/June 2009): 32-41.

Latour, Bruno. "Air." Sensorium: Embodied Experience, Technology and Contemporary Art. Cambridge, MA: MIT Press, 2006.

Lutgens, Frederick. K. The Atmosphere: an introduction to meteorology. Upper Saddle River, NJ: Prentice Hall, 2004.

Manacorda, Francesco. Radical Nature: Art and Architecture for a Changing Planet, 1969-2009. Koln: Walther Konig, 2010.

May, Susan. "Meteorologica." Olafur Eliasson: The Weather Project. London: Tate Modern, 2003.

Merleau-Ponty, Maurice. The Phenomenology of Perception.

London: Routledge, 2002.

Noever, Peter and Francois Perrin. Yves Klein: Air Architecture. Los Angeles: MAK Center for Art and Architecture, 2004.

Otero-Pailos, Jorge. "The Ambivalence of Smoke: Pollution and Modern Architectural Historiography." Grey Room. 44 (2011): 90-113.

Pollio, Marcus Vitruvius. Trans., Morris Hicky Morgan. "Book VI." Ten Books on Architecture. Digireads.com, 1 Jan. 2005.

Salazar, Jaime. "MVRDV, VPRO." Olafur Eliasson: Surroundings Surrounded. Graz, Austria: Neue Galerie, 2000.

Speiker, Sven. The Big Archive. Cambridge, Massachusetts: MIT Press, 2008.

Stalder, Lurnet. "Air, Light, and Air Conditioning." Grey Room. 40 (2010): 84-90

Weibel, Peter. "Over and Beyond the Limits of Reality." Lecture held at the Ars Electronica 92 Symposium, Linz, Austria.

Zabel, Bernd et al. "Construction and engineering of a created environment: Overview of the Biosphere 2 closed system." Ecological Engineering. 13 (1999): 43-63.

# **HYPERSensarium:**

An Archive of Atmospheric Conditions

by Kelly E Shaw

Bachelor of Science in Product Design  
Stanford University, 2006

Submitted to the Department of Architecture on February 17, 2013 in partial fulfillment of the requirements for the degree of Master of Architecture at the Massachusetts Institute of Technology.

© 2013 Kelly Shaw. All rights reserved.