

ATMOSPHERIC APPARATUS

The Production of Another Comfort Paradigm

by **Hung Fai Tang**

B.S.Sc (Architectural Studies), 2006
The Chinese University of Hong Kong

Submitted to the Department of Architecture
in Partial Fulfillment of the Requirements for the Degree of

Master of Architecture

at the

Massachusetts Institute of Technology

February 2013

ARCHIVES

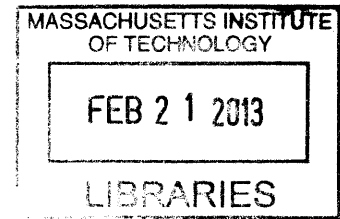

© 2013 Hung Fai Tang. All rights reserved

The author hereby grants to MIT permission to reproduce and to distribute publicly paper and electronic copies of this thesis document in whole or in part in any medium now known or hereafter created.

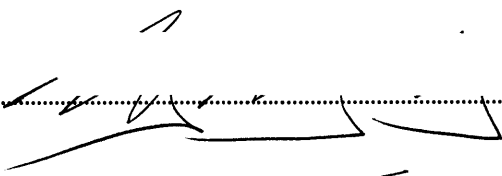
Signature of Author

Department of Architecture
Jan 17, 2013

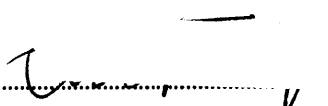
Certified by

Nader Tehrani
Professor of Architecture
Thesis Supervisor

Accepted by

Takehiko Nagakura
Associate Professor of Design and Computation
Chair of the Department Committee on Graduate Students

THESIS COMMITTEE

Thesis Supervisor:

Nader Tehrani

Professor of Architecture

Department Head

Thesis Readers:

Christoph Reinhart

Associate Professor of Building Technology

Joel Lamere

Assistant Professor of Architecture

ATMOSPHERIC APPARATUS

The Production of Another Comfort Paradigm

by **Hung Fai Tang**

Submitted to the Department of Architecture on January 17, 2013
in Partial Fulfillment of the Requirements for the Degree of Master of Architecture

ABSTRACT

Nowadays, being thermal comfort is no longer a challenging problem for modern living. With the aids of the modern environmental control technologies, a fast, convenient and effective thermal comfort experience can be easily obtained with less effort than ever before. And due to the technologies' capabilities, this comfort experience can be universally adopted anywhere regardless of the physical location and climate condition.

However, this widely adopted comfort experience has been proved to be problematic due to its nature of producing comfort. The highly technological dependent and the energy reliance approach are not suitable for a sustainable development.

Therefore, the goal of the thesis is to challenge this modern comfort experience and argue there exists "another comfort paradigm" in which a new kind of atmospheric experience is obtained by architectural intervention. And, the thesis proposes Atmospheric Apparatus as a new architectural typology to generate alternative thermal experiences for new comfort paradigm. In order to define the "another comfort paradigm," the thesis examines the current modern comfort phenomenon on its production, impacts and experience. Then, the thesis studies the scientific knowledges of thermal comfort and the thermodynamic relationship between human body and the atmosphere. Lastly, there are architectural proposal of the Atmospheric Apparatus for "another comfort paradigm."

Thesis Supervisor: **Nader Tehrani**

Title: Professor of Architecture, Department Head of Architecture

ACKNOWLEDGMENT

Here I would like to express my greatest gratitude to all of following people to make my life and thesis possible at MIT.

To Nader Tehrani, my rigorous advisor, for offering me an unforgettable thesis experience in MIT. Thank for your critical comments, humorous jokes and motivative encouragements.

To Christoph Reinhart and Joel Lamere, my thesis readers, for your design comments.

To Gediminas Urbonas, my inspiring ACT class instructor, for providing me with many insightful comments and encouragement.

To Jessica Chia Chie Lee and Li Huang, my best friends since the beginning of MIT, for offering your greatest supports during the critical moment of my thesis.

To Cecilia Sze Wai Ho, Jasmine Kwak, Shiyu Appian Wei, Shaoyi Liang, Aditya Barve, Joshua Choi, Menglin Jiang and Kui Xue, my professional helpers, for rescuing me to make my thesis happened.

To the class 2013 for sharing many joys and being supportive during the entire time at MIT.

To my parents, sister and aunts, for supporting me with your generous understanding to pursue my dream.

Last but not least, to Kerry Ka Lam Wong, my special one, for sharing me your joy and smile when I have tough time. :)

CONTENTS

01 | INTRODUCTION: TWO COMFORT PARADIGMS

Modern Comfort
Another Comfort Experience

02 | PHENOMENON: MODERN COMFORT

Modern Comfort Development
Pursuit of Techno-Comfort
Hermetically Sealed Typology
International Style
Energy Paradigm

03 | INQUIRIES: THERMAL COMFORT

Human Comfort and Thermal Comfort
Thermal Equilibrium
Mechanism & Factors
Optimal Atmospheric Condition
Psychometric charts
Domestic Apparatus

04 | PROPOSAL: ATMOSPHERIC APPARATUS

HEAT | °C, °F
HUMIDITY | %
WIND | m/s

APPENDIX

Thesis Defence

BIBLIOGRAPHY

01 | **INTRODUCTION** -- TWO COMFORT PARADIGMS



Fig.1. 1956 Ad General Electric Air Condition Ads.

Image source: <http://www.amazon.com>

MODERN COMFORT

In 1902, when Willis Haviland Carrier invented the world's first modern electrical air conditioning unit¹, it symbolized the environmental condition technology has entered the modern era. The modern paradigm guaranteed convenient, effective and fast comfort experience. Actually, the modern comfort experience is highly constituted of the premises of technologies applications and energy consumption. While these two premises have gradually transformed the modern lifestyle and eventually reflected on architecture design, building industry and energy practice.

In the modern comfort, technology plays an important role to maintain a stable and comfortable living environment. For example, the modern air conditioning regulates the atmospheric condition to control air temperature, humidity levels and air ventilation. The air conditioning simply resolve the complex thermal comfort challenge for people. As a result, he modern skyscrapers and shopping malls are specific architecture typology benefited from the use of air conditioning. And gradually, the modern comfort became highly reliance on technologies.

In addition to technologies basis, the modern comfort experience is constructed on energy oriented approach. As a consequence of the employment of the active condition system, high energy input is required to support the system operation and performance. According to Reyner Banham in his *The Architecture of the well tempered environment*, he regards this approach as "power-operated solution"².



Fig. 2 Digestable gulf stream by Philippe Rahm

Image source: <http://www.designboom.com>

ANOTHER COMFORT PARADIGM

The modern comfort promises us with a favorable living environment for comfort's desire. However, the technological and energy oriented paradigm of modern comfort have become frictional resistance to pursue a sustainable future. The persistent technological failure, the irreversible energy crisis technological as well as the severe climate change have revealed the fact that the promises of modern comfort may fail some days.

Therefore, the goal of the thesis is suggesting there exists another comfort paradigm, in which the thermal comfort experience is obtained differently from the existing modern approach. The focus of this another paradigm is shifting from the technological and energy basis towards the inter-relation between the human body and the situated atmosphere. Thus, the human body, the atmospheric condition and the accommodating architecture are the critical re-considering subjects of the thesis.

Within the new paradigm, three architectural experimental type are proposed as Atmospheric Apparatus in responding to the production of another comfort experience. The three experimental types are designed according to three primary atmospheric factors: temperature, humidity and wind in order to induce respective atmospheric experiences.

1. Willis Carrier, Wikipedia, http://en.wikipedia.org/wiki/Willis_Carrier Retrieved 01.23.2013

2. Reyner Banham, *The Architecture of the Well Tempered Environment* (London: The Architectural Press, 1969), 19.

02 | **PHENOMENON** -- MODERN COMFORT

MODERN COMFORT DEVELOPMENT

TECHNOLOGY

ARCHITECTURE

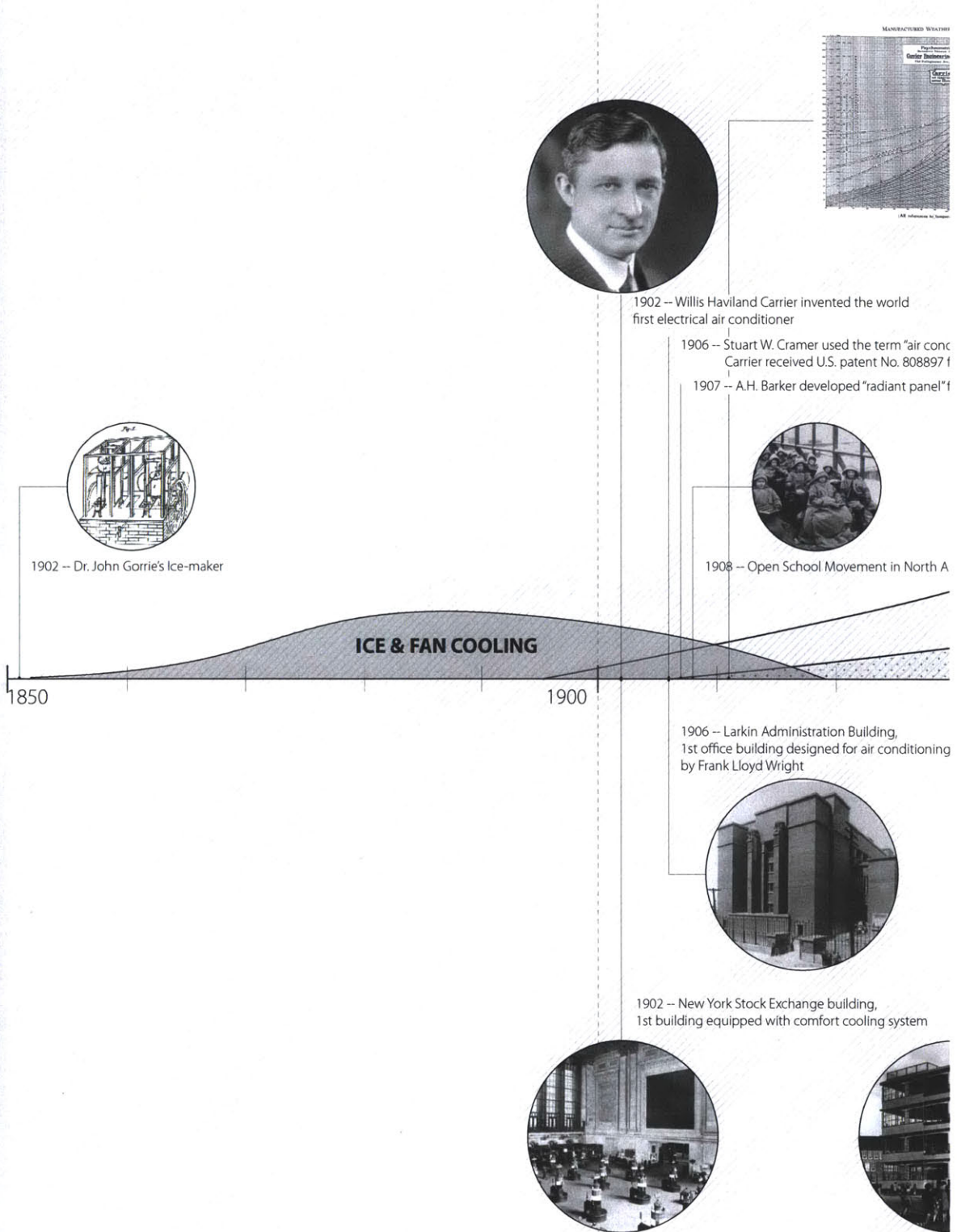
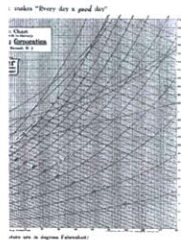
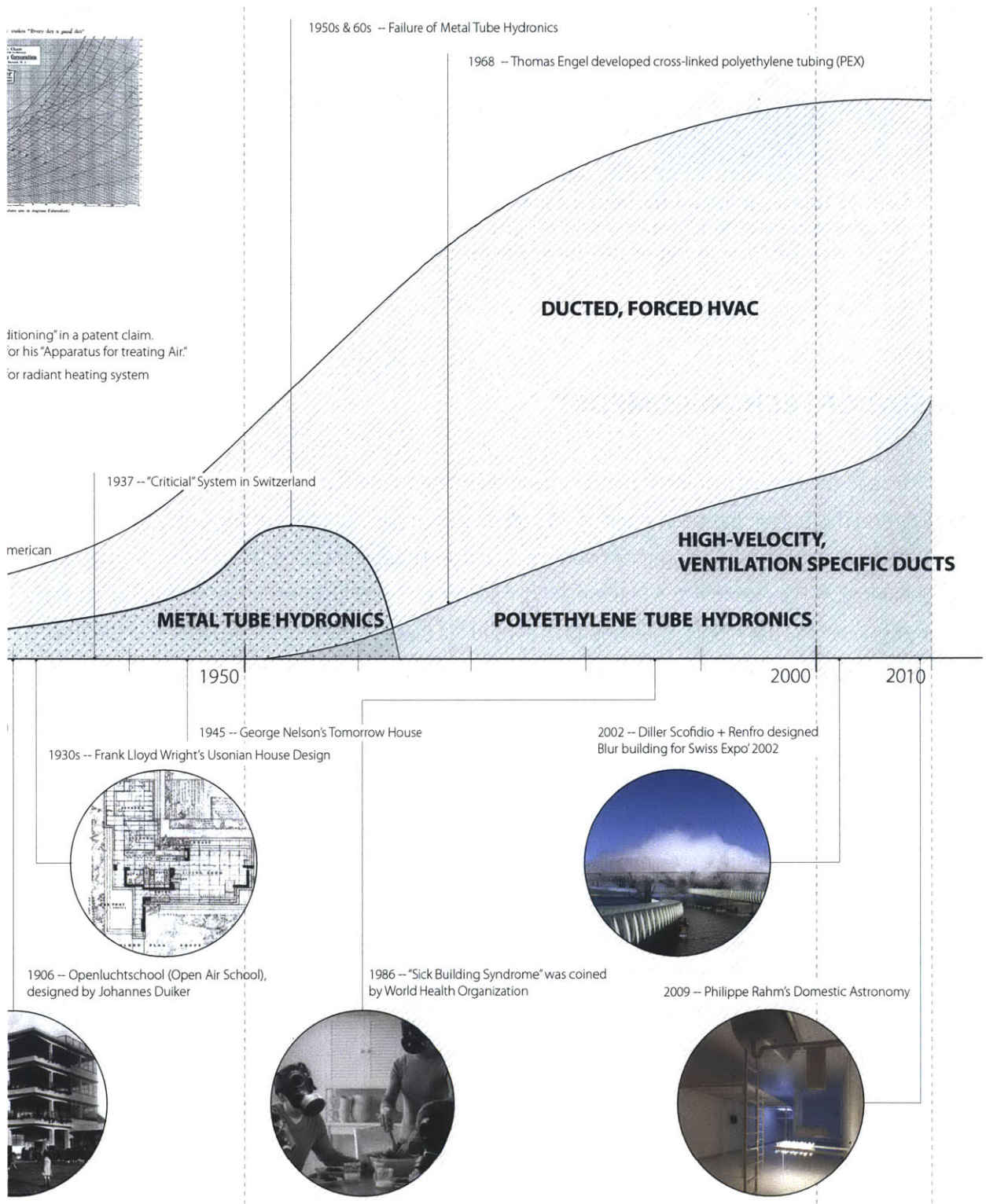

Fig.3. Modern conditioning technology development



conditioning" in a patent claim.
 or his "Apparatus for treating Air."
 or radiant heating system



Reference: Kiel Moe, *Thermally Active Surfaces in Architecture* (New York: Princeton Architectural Press, 2010) 34



**Fig 4. Left: People sleeping on tradition Chinese Kang
Middle: Mid Tradition Korean Ondol for floor heating
Right: Ancient Roman Hypocaust for space heating**

PURSUIT OF TECHNO-COMFORT

Due to the natural comfort desire, pursuing thermal comfort has become an important cultural activities. And this pursuit has been significantly influencing architecture and technologies development. Various thermal comfort technology has been employed and integrate to building construction to favor interior habitation. For example, the Chinese Kang, the Korean Ondol and the Roman hypocaust³ as well as many other vernacular architecture around the world. All these architecture were reflecting the their respective knowledges on thermal comfort technology and actualizing them in building.

Then, until the Industrial Revolution, people began the Industrial Age and followed by Machine age in history. The science knowledges and technologies advancement have been resulted in a paradigm shift for the pursuit of thermal comfort and architectural design. In this paradigm, seeking for comfort has been engineered towards a scientific approach. For example, the Franklin stove, invented in late 18th century, with better performance and effective solution for smoke problem has dramatically transformed the heating for domestic living. Then, during the early 20th century, people were further fascinated by various spatial conditioning technologies developed and devote to live in a conditioned interior environment. Due to the desire and technological development, these conditioning technology had been widely applied to domestic space in which, a well conditioned living was perceived as luxury. As a result, living in a conditioned interior was regarded as a modern existence.

In the entire 20th century, people were enjoying the thermal comfort achieved by these modern technology, however, when these conditioning technologies became more widely adapted, various problems and related consequences emerged. Since these technologies required to maintain a stable

condition, much energy were consumed to maintain a steady thermal performance, which results in energy and economics problem followed with inter-country relations. Since 70s, the over demands of energy has turned to energy crisis in major industrial nations and eventually developed further to an international global problem. Meanwhile, these technologies have performance problems which consequently became various critical issues when these technologies lack of maintenance or even fail.

In recent decays, debate have been started over this technological determinism, the discussion has related to global sustainable topic in which the more adaption of technology, harder for human's survival in the future due to climate change, energy shortage, political conflict resulted due to these impacts. People begin questioning and doubt the necessity on technological solution to condition living environment, thus various "green" movements, which encourage sustainable technologies or restore to basic and learn from the tradition and history, emerged to reconsider the technologies application on conditioning living environment.

In summary, modern conditioning technologies provides many effective and solutions to achieve thermal comfort in modern time, however, their energy consumptions and inadequate application may results in un-desirable condition to the users in the building. Thus, regardless users or building industry, it is requires a new mentality and attitude to re-consider the applications of technology and avoid over reliance on them in order to foresee a sustainable comfortable future living.

.....
**ONE HOUSE FOR
ALL COUNTRIES**

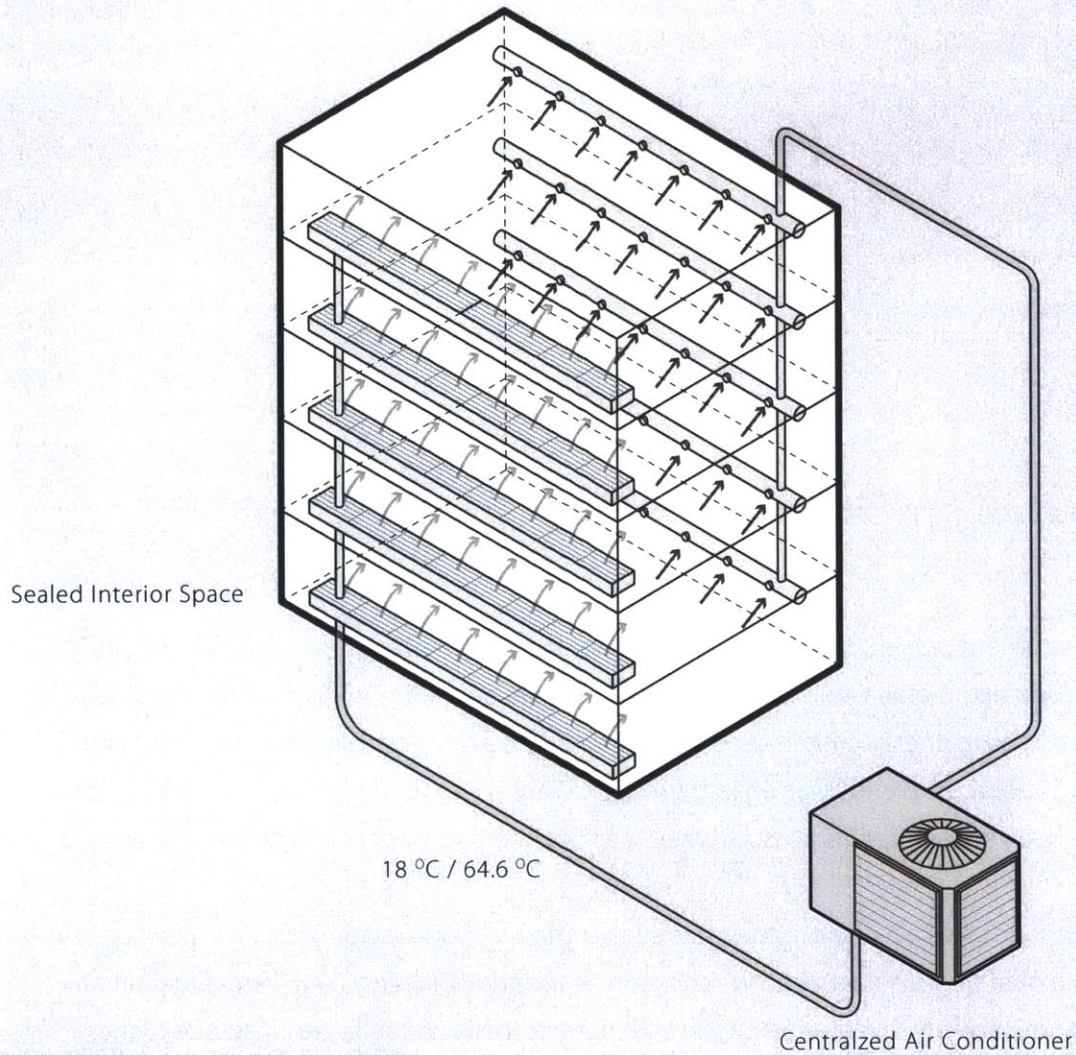

Fig 5. One houses for all countires

“Every country builds its houses in response to its climate. At this moment of general diffusion, of international scientific techniques, I propose: only one house for all countries, the house exact breathing... I set up the factory for the production of exact air. It is a small establishment, a few small space; I produce air at 18 °C humidified according to seasonal needs. With a ventilator, I blow this air through carefully laid-out conduits. Means of expansion for this air have been invented to avoid drafts. Air comes out. This system at 18oC will be our arterial system. ... The Russian House, the Parisian, at Suez or in Buenos Aires, the luxury liner crossing the Equator will be hermetically sealed. In winter it is warm inside, in summer cool, which means that at all time there is clean air inside at exactly 18 °C”⁴

.....

HERMETICALLY SEALED TYPOLOGY

As previously mentioned in "Pursuit of (techno) Comfort," the modern conditioning technologies development provided effective thermal comfort solutions for domestic living. Meanwhile, these technological approach amazed architects and inform the Modernism Architecture development in the 20th century. The sketch on the opposite page is sketch once proposed by Le Corbusier during one of his lectures at Buenos Aires. During the lecture, he once suggested "one house for all countries," in he would imagine it acted like a human "breathing pure air, at a constant temperature and a regular degree of humidity" with the aids of international scientific techniques.⁵ In the house, it was serviced by modern conditioning technology to provide air at a constant temperature of 18 degree Celsius to operate the interior space. And this air was continuously circulating within the building with the helps of machine for cooling, humidifying and purifying. The entire system was regulated with standard and scientific quantity. Furthermore, he even proposed an architectural intervention called, Neutralizing Wall, when he was questioned how to maintain the constant temperature when outside temperature were forty degree higher or lower.⁶ Therefore, his neutralizing wall, a glass envelope wrapping around the building, would prevent the "air at 18 °C " from any external influence. And in between the glass and building, heated air will circulate to maintain the interior condition stable. Lastly he provocatively suggested to hermetically seal this house, so it could be build around the world, such as at Russia, at Paris and at Bueno Aires with "clean air exactly 18oC."⁷

In fact, the "one house for all countries" by Le Corbusier has been generally adopted in following Modernism Movement and become the *hermetically sealed typology* referred here. This universal and generic architectural proposition consisted of three important notions to shape Modernism Architecture spatial configuration: 1. Hermetically Sealed: Building is totally isolated from its external climate and environment to maintain an uninterrupted internal space; 2. Constant Interior Condition: A standardized and universal atmospheric condition was maintained with regulated temperature and humidity, the modernists believed this constant and stable condition will provide the maximum comfort for the occupants; and lastly, 3. Machinery Servicing Dependent: Intensive mechanical servicing and conditioning machineries are required to achieve the interior condition, it reflected the Le Corbusier's philosophy of The house is a machine for living in.⁸

4. Le Corbusier, *Precisions* (Cambridge, Mass: MIT Press, 1991), 64-66

5. Ibid, 64

6. Ibid, 66

7. Ibid, 64

8. Le Corbusier, *Toward an Architecture* (London: Architectural Press 1946)

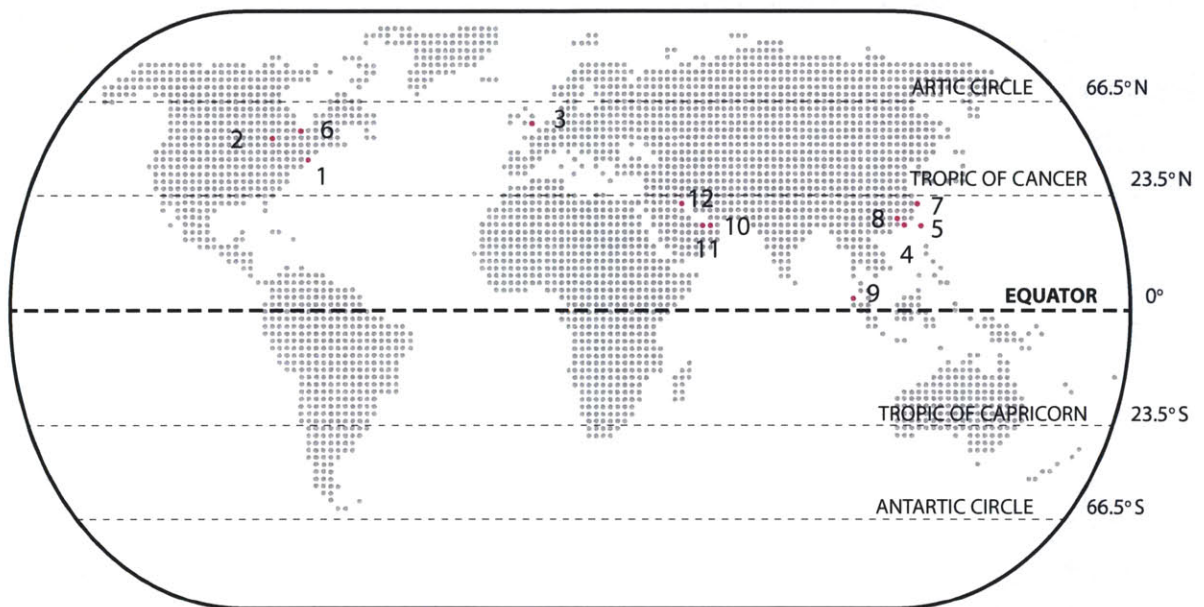

Fig.6. Global location map



1. NEW YORK



2. CHICAGO



3. LONDON



4. HONG KONG

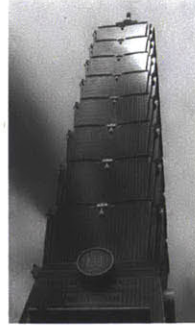

5. TAIPEI



6. TORONTO



7. SHANGHAI



8. GUANGZHOU



9. KUALA LUMPUR



10. ABU DHABI



11. DUBAI



12. KUWAIT CITY

INTERNATIONAL STYLE

As a result of this hermetically sealed typology, international style has benefited from the technology and energy base modern condition approach. And the skyscraper typology has spread all over the world.

Fig.7. US Primary Energy Consumption Estimates by Source, 1775-2011

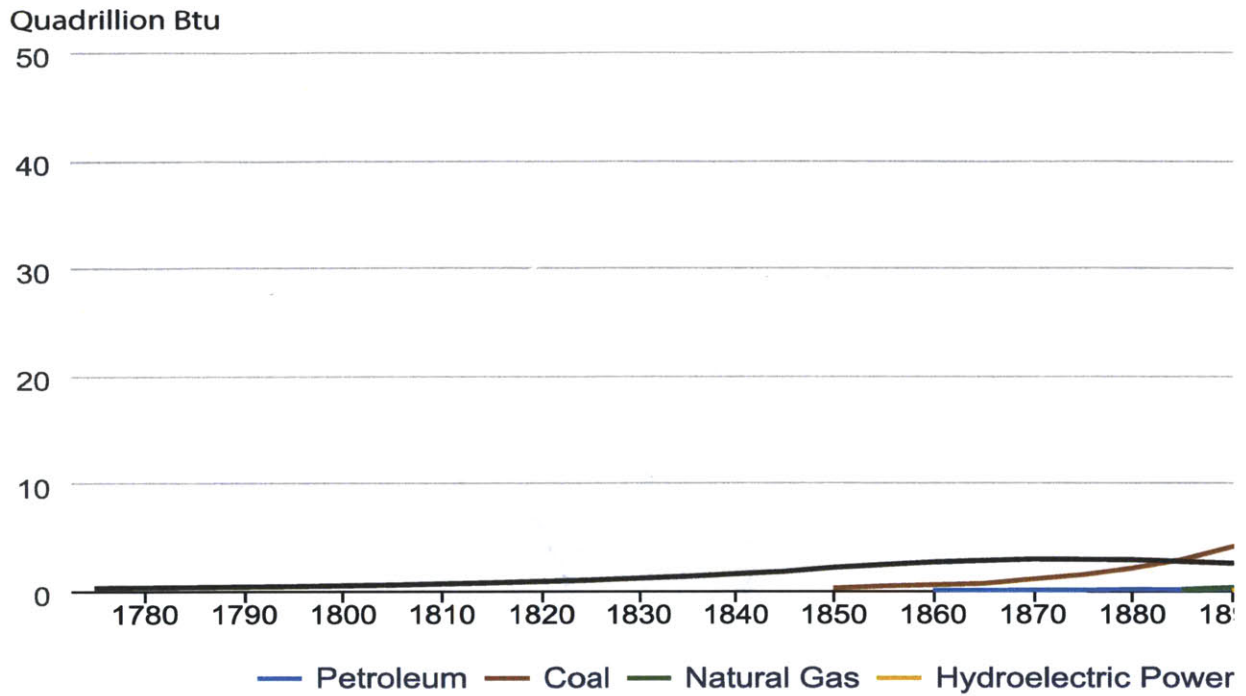

ENERGY PARADIGM

According to the Building Data Book from US Department of Energy, the energy consumption for thermal comfort conditioning including heating and cooling in domestic context have been over 50% of total residential energy use, and this percentage is equivalent to 11.6% of total energy consumption in United States annually.

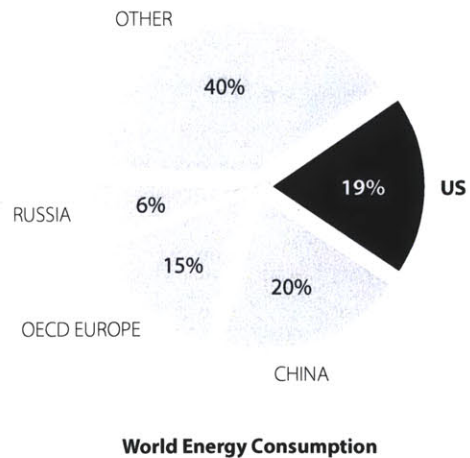

Source: U.S. Energy Information Administration, Energy Perspectives 2011, September 27, 2012.

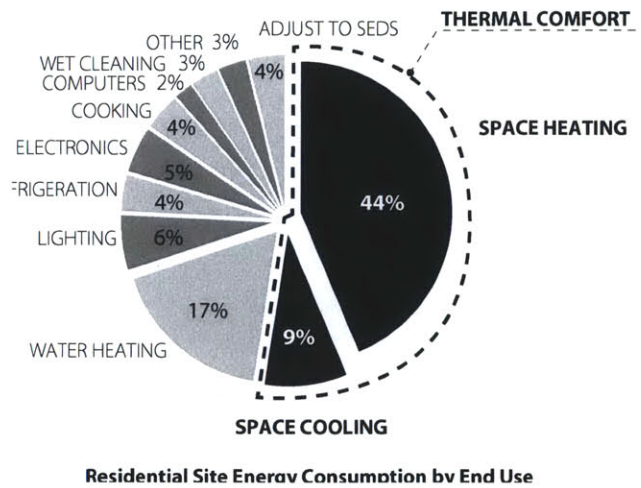
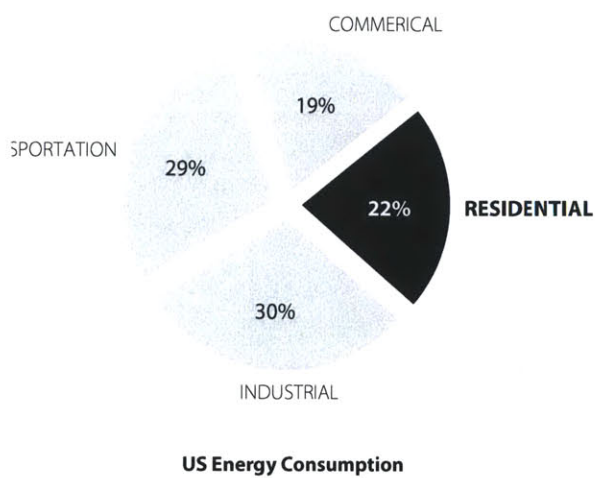
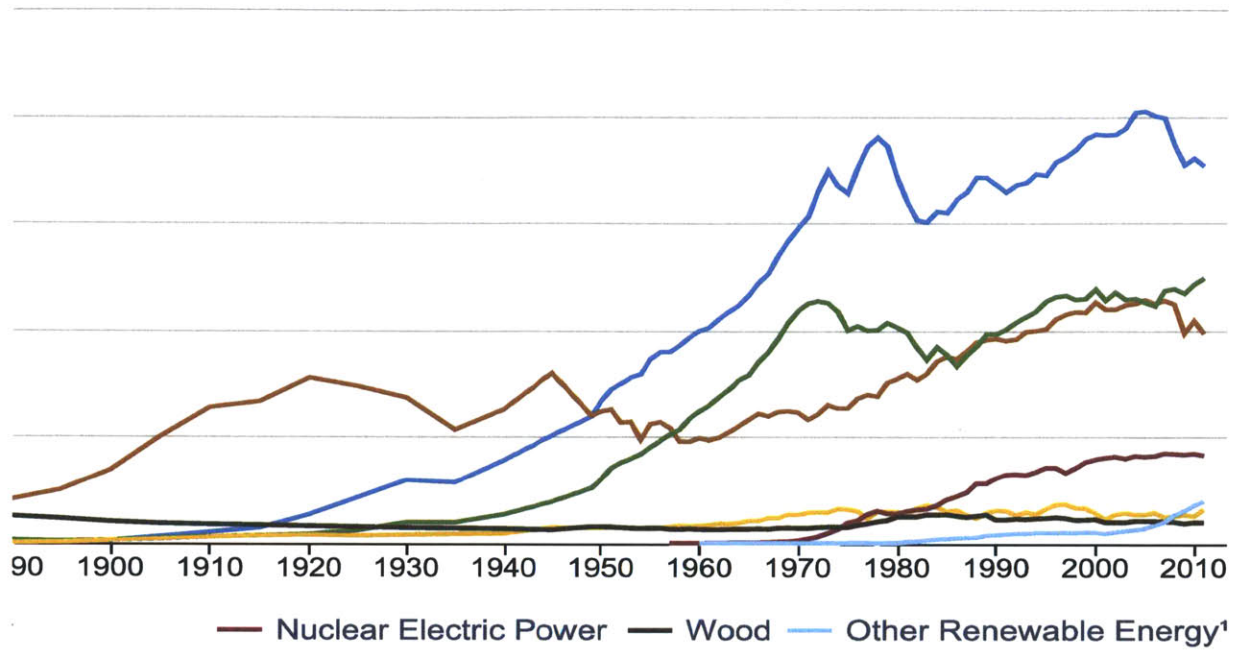

Source: U.S. Department of Energy: Building Energy Data Book

.....
03 | **INQUIRIES** -- THERMAL COMFORT
.....

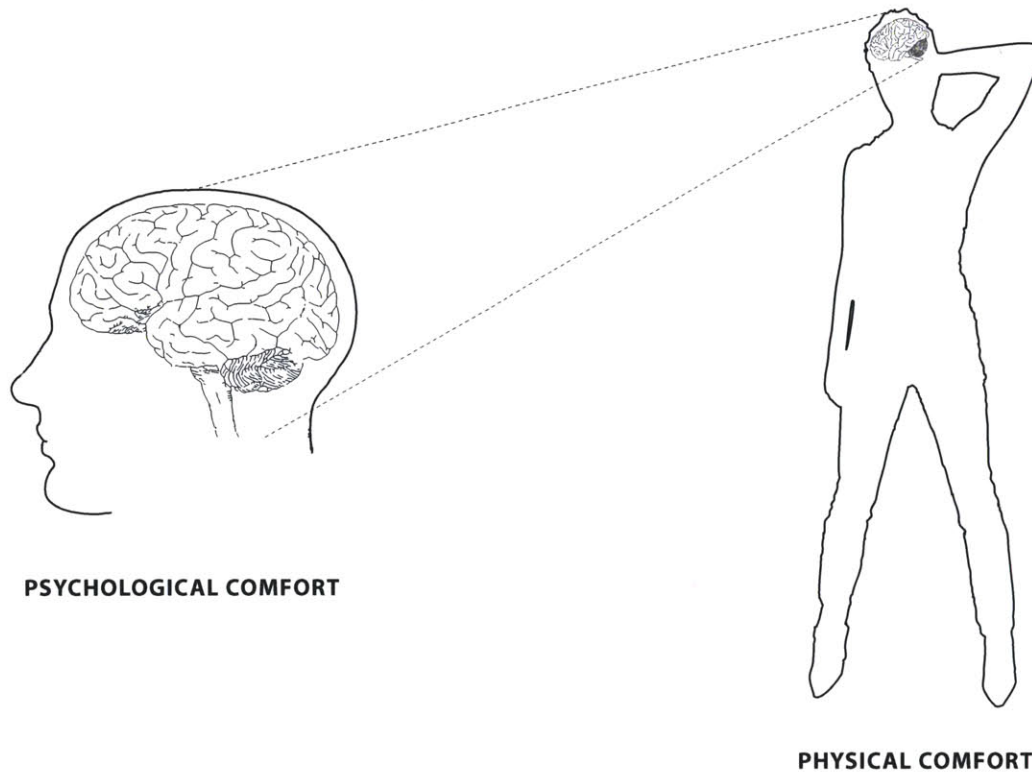

HUMAN COMFORT

Basically, human comfort is referring to both physical and psychological ease, and these comforts can be easily achieved through various means, **psychological comfort** can be achieved by recalling of previous experience from seeing an object, the appreciation of an art piece and the intake of food. And the body **physical comfort** is more related to the situated environment and its corresponding atmosphere including temperature, humidity, lighting and odor. These various conditioning factors will create stimulation on body sensation system and developed a overall perception of comfort.

COMFORT

1. *"A sense of physical or psychological ease, often characterized as a lack of hardship. Persons who are lacking in comfort are uncomfortable, or experiencing discomfort."*

(Wikipedia of Comfort)

2. *"Comfort is best defined as the absence of discomfort."*

(Bradshaw, Vaughn, and Vaughn Bradshaw. 2006. The building environment: active and passive control systems. Hoboken, N.J.: Wiley.)

THERMAL COMFORT

1. **Not too hot or not too cold**

(Spontaneous Human sensation)

2. *"The state of mind in humans that expresses satisfaction with the surrounding environment."*

(ANSI/ASHRAE Standard 55)

THERMAL COMFORT

Human body has an amazing sensibility for thermal comfort, it is a simple and reliable sensational ability to tell body its physiological feeling within a thermal condition. However, this sensation is always rather difficult to describe and define. For example, *"Comfort is best defined as the absence of discomfort,"*⁴ for example; human will tend to describe it as not too hot or not cold when defining the comfort state. In other words, positive comfort conditions are not distracted by causing unpleasant sensations of temperature, drafts, humidity, or other aspects of the environment.⁵ According to Bradshaw in his The building environment, an ideal thermal is that state of mind that is satisfied with the thermal environment.

⁴ Vaughn Bradshaw, The building environment : active and passive control systems (Hoboken, N.J.: Wiley, 2006), 4

⁵ Ibid, 5

THERMAL COMFORT



THERMAL EQUILIBRIUM



HEAT GAIN = HEAT LOSS



$$M = C \pm R \pm E \pm S^*$$

THERMAL EQUILIBRIUM

According to "Design with Climate" written by Olgay Victor, he stated that the human thermal comfort can be understood according to thermodynamics principles to maintain a thermal equilibrium between the body and the environment. And their respective thermodynamics relations can be translated mathematically into a Thermal Equilibrium Formula, in which the previous mentioned comfort parameters are integrated in various heat exchange mechanisms in the formula:

$$\text{HEAT GAIN} = \text{HEAT LOSS} \quad \text{or} \quad \mathbf{M = C \pm R \pm E \pm S^*}$$

*where:

M = metabolic rate,

E = the rate of heat loss by evaporation,

R = radiation rate,

C = conduction and convection rate, and,

S = the body heat storage rate.

At the point when heat generated (or heat gained) by body metabolism is equal to the overall heat gained or loss by convection, conduction, radiation and evaporation, a thermal equilibrium state is established within the body. In other words, at this equilibrium point, a human thermal comfort is obtained.

In all, the body thermal comfort gives an interesting architectural proposition to relate to spatial configuration in order to influence thermal exchange mechanisms in order to provide a human body a thermally comfortable habitation environment.

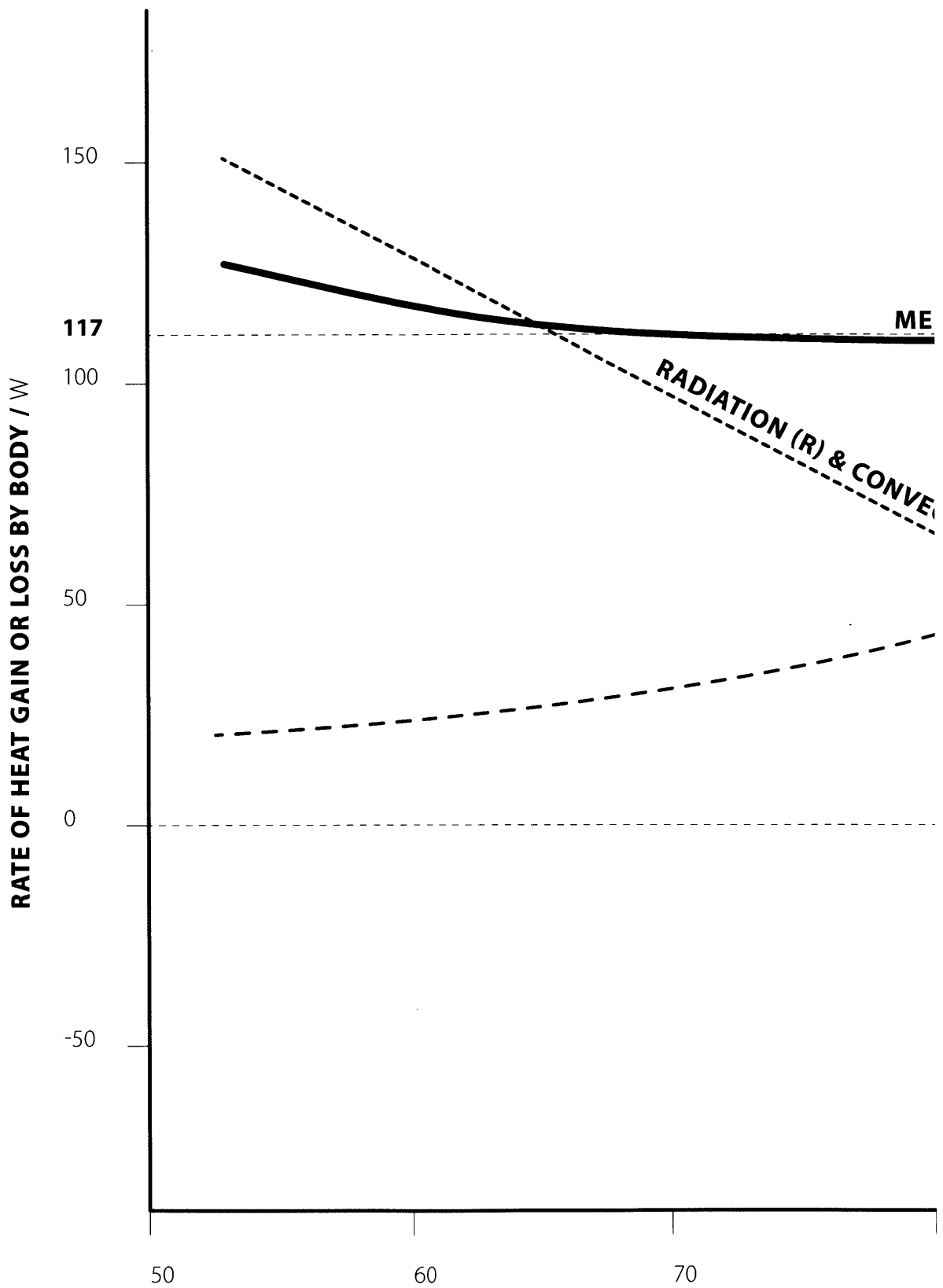
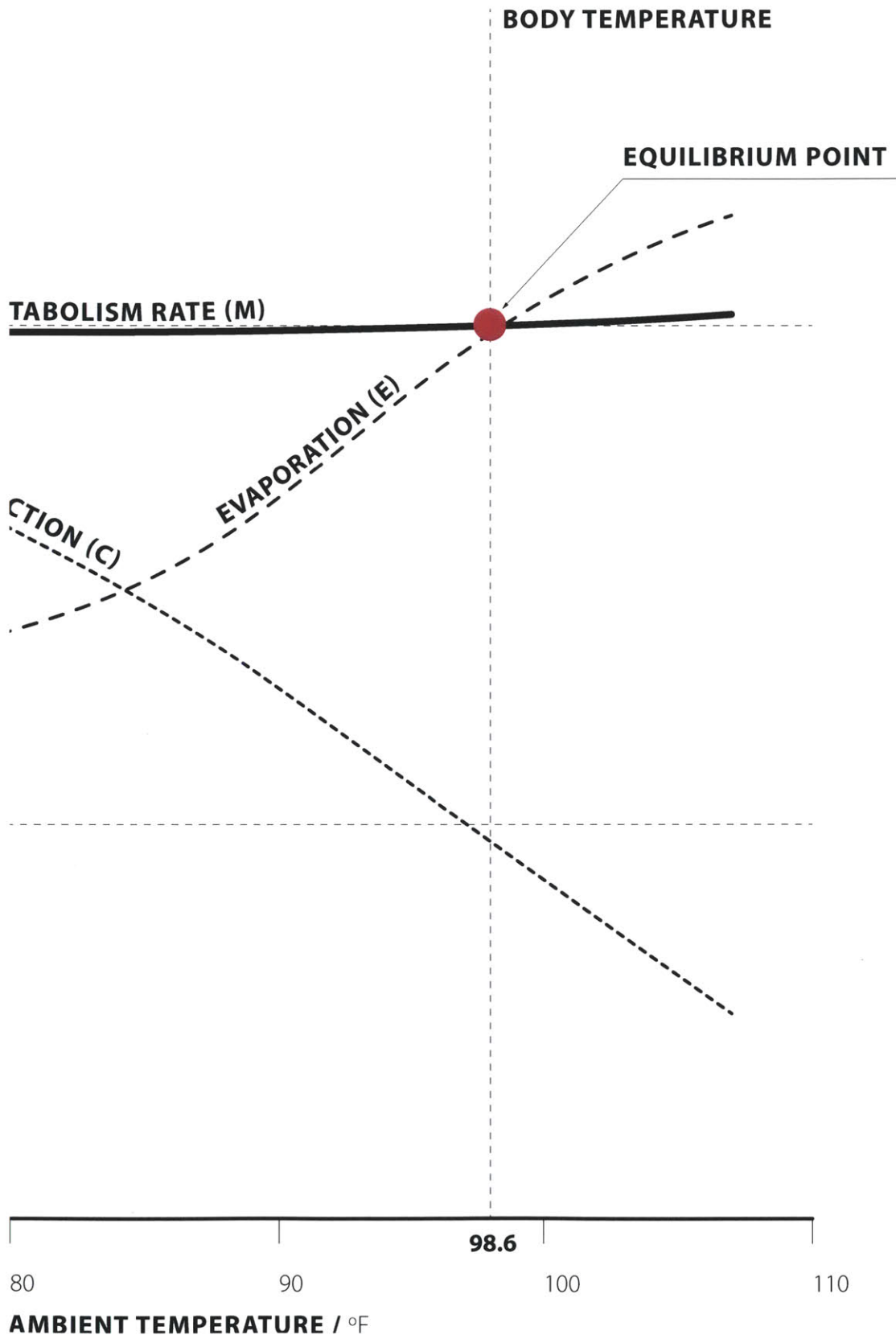
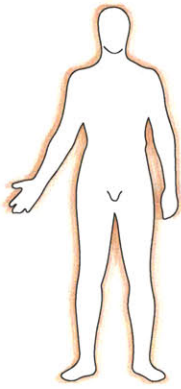

Fig.8. Relation of thermal exchange



Source: Vaughn Bradshaw, *Building Control Systems*, (New York: Wiley 1993), 12



RADIATION / R

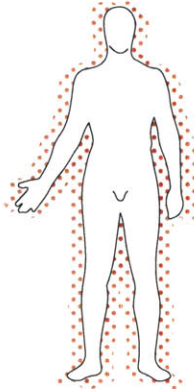

CONVECTION / C

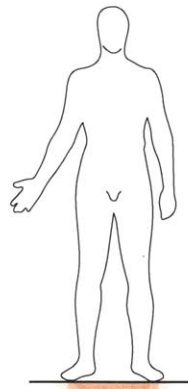

CONDUCTION / C

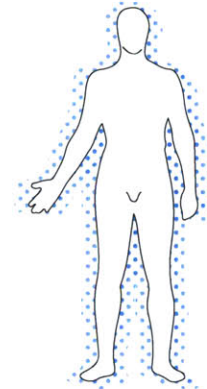

EVAPORATION / E

MECHANISMS & FACTORS

In order to maintain the thermal equilibrium within the body, there are four thermodynamic mechanisms for the body to have heat exchange between the environment:

Radiation is the radiant energy transferred mechanism due to the heat content of an object. Human body is constantly undergoing radiation exchange by gaining heat from or losing heat to its surrounding environment.

Convection occurs when air passes over the body skin surface and brings sensible heat to or away from the body.

Conduction happens when the body has direct contact to any surface which has temperature difference from the body.

Evaporation is the only cooling process for human body to lose heat through perspiration, sweating and respiration by converting liquid to gas.

FACTORS

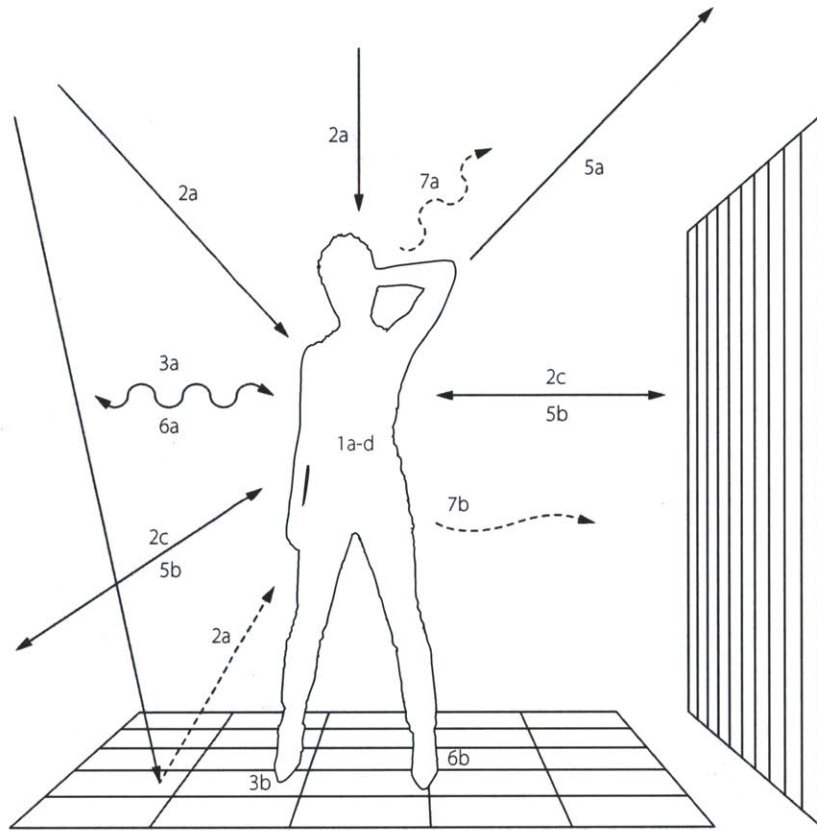

	HEAT GAIN	HEAT LOSS
METABOLISM	1a) Basal Processes 1b) Activity 1c) Digestive, etc. processes 1d) Muscle tensing and shivering in response to cold	
RADIATION	2a) From Sun directly or reflected 2b) From glowing radiators 2c) From non-glowing hot objects	5a) To "sky" 5b) To colder surroundings
CONDUCTION CONVECTION	3a) From air above skin temperature 3b) By contact with hotter objects	6a) To air below skin temperature (hastened by air movement-convection) 6b) By contact with colder objects
EVAPORATION	4) Condensation of atmospheric moisture (occasional)	7a) From respiratory tract 7b) From skin

Fig.9. Atmospheric Factors

Reference: Victor Olgay. *Design with climate*. (New York: Princeton University Press 1963), 16

**BODY
TEMPERATURE**

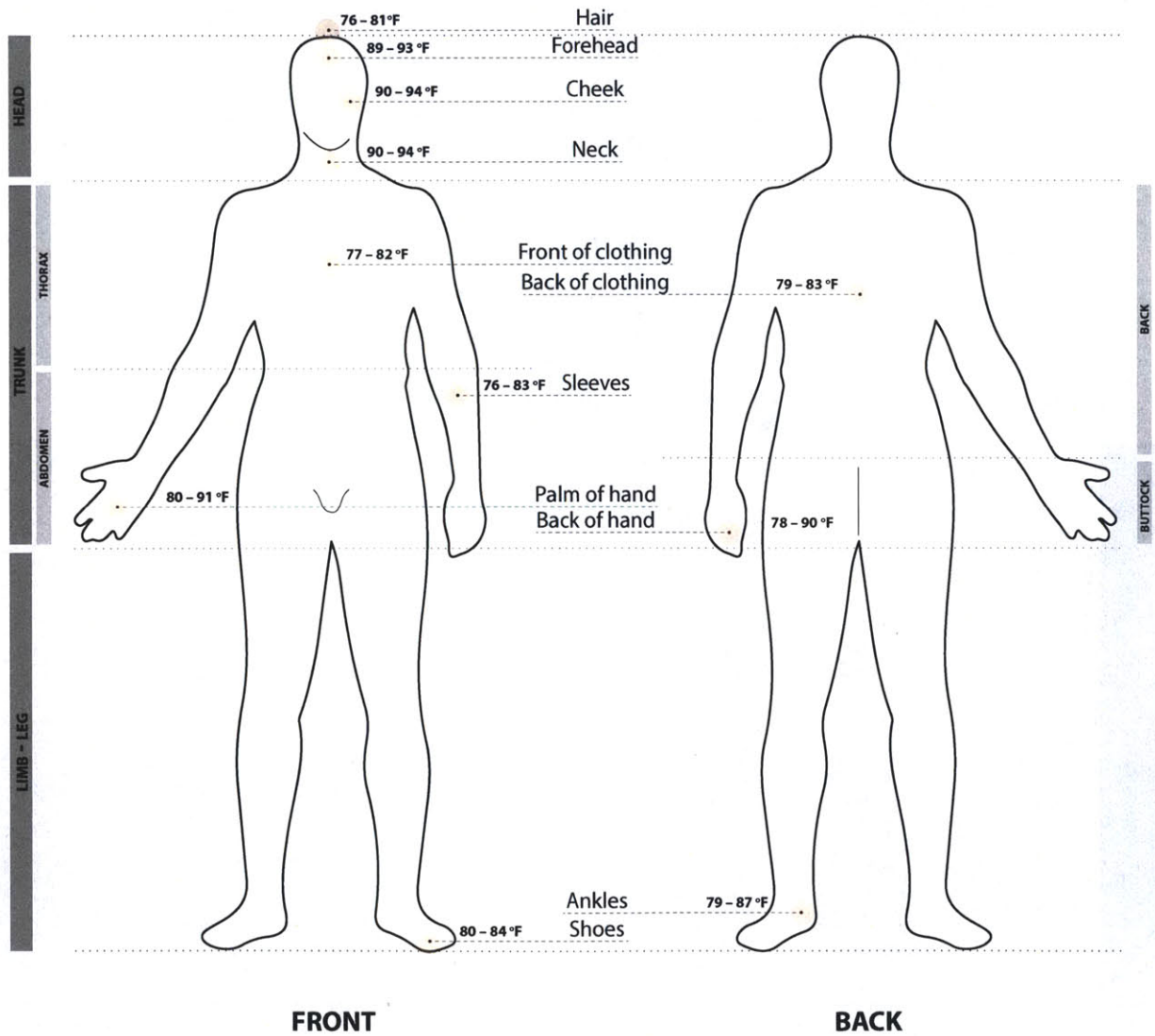

Fig.10. Human Body Temperature
Reference: Moe, *Thermally Active Surfaces in Architecture*, 71

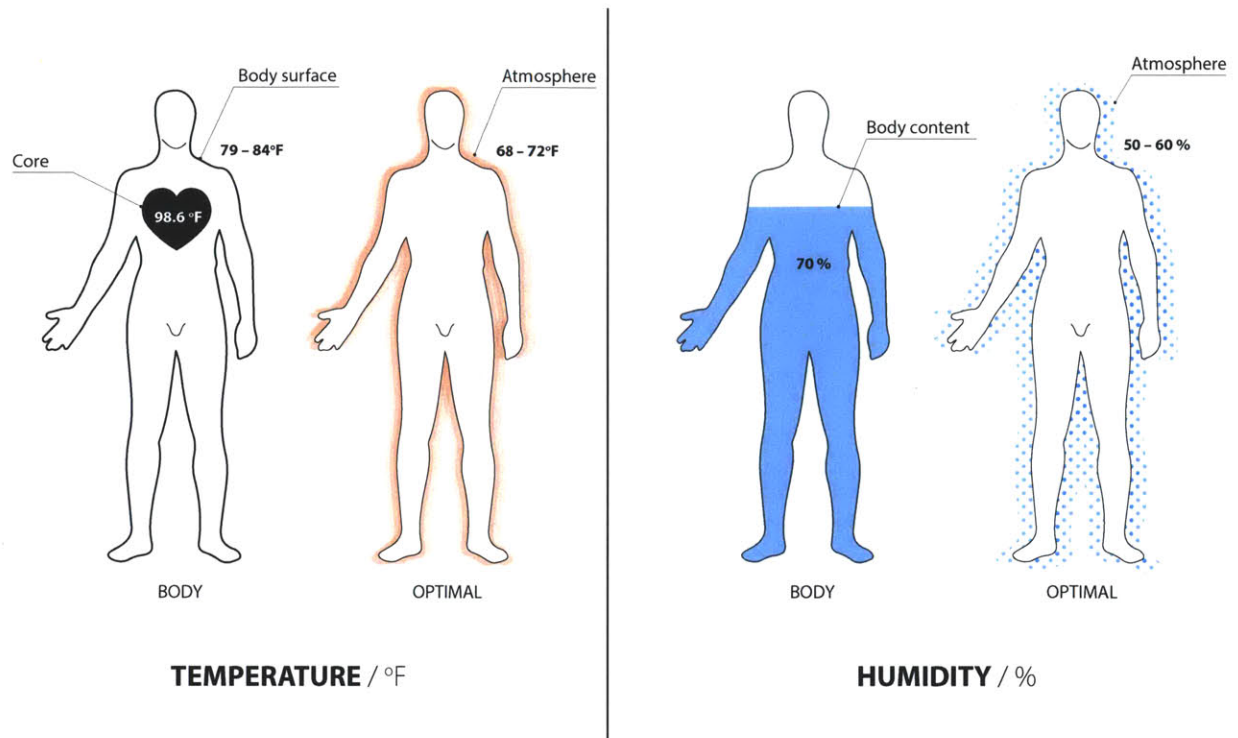

Fig.11. Human Body and Optimal Condition

Reference: Jürgen Mayer and Neeraj Bhatia, -arium: Weather + Architecture, (Ostfildern: Hatje Cantz, 2010) 59

OPTIMAL ATMOSPHERIC CONDITION

Due to the complexity of the body structure and the dynamic atmospheric condition, it is impossible to achieve a definite thermal equilibrium, thus, there is optimal temperature and humidity range in which the body obtain maximum thermal comfort. Meanwhile these optimal atmospheric conditions are also important for human body normal function.

PSYCHROMETRIC CHART

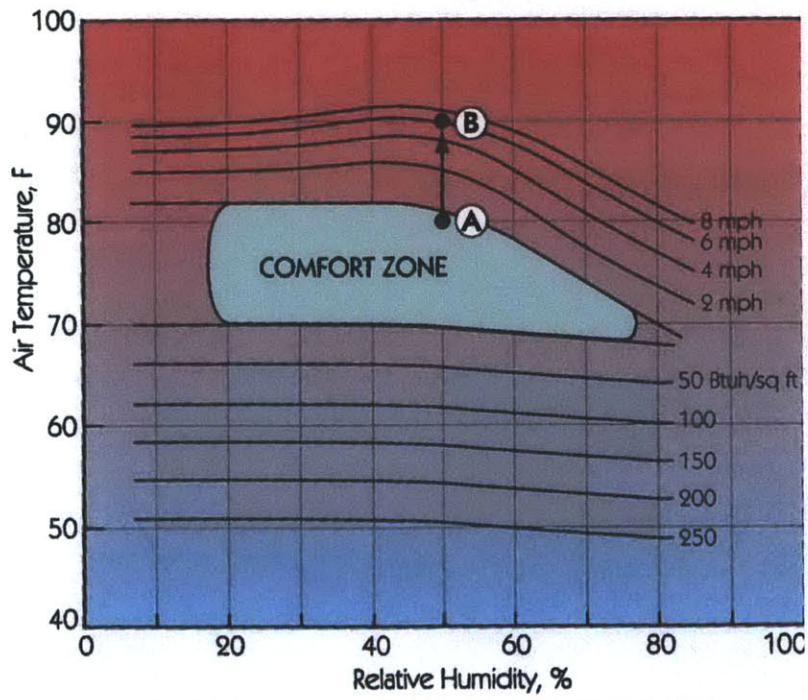
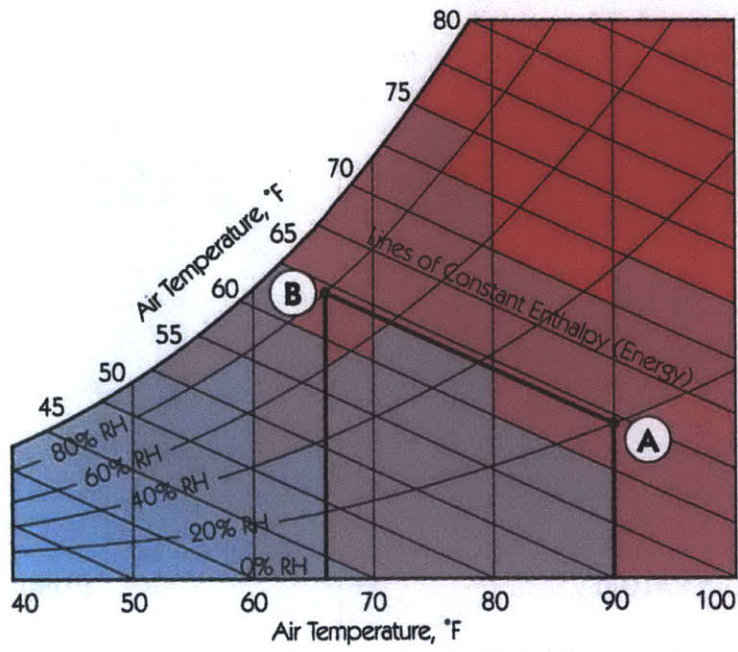
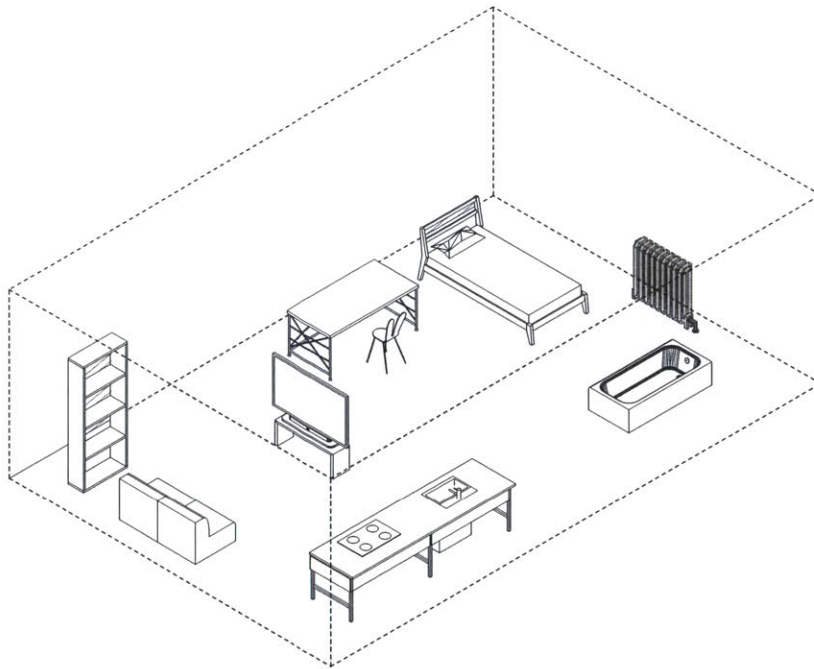

Image Source: Charlie Wing, How Your House Works, (New Jersey: Wiley 2012) 93 & 97

DOMESTICS APPARATUS



DOMESTIC HEATING



Thermostat

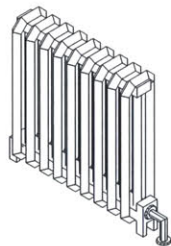

Radiator

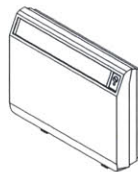

Air heater



Space Heater

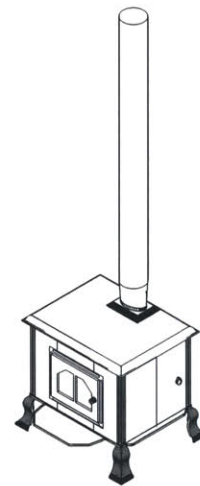

Franklin Stove

DOMESTIC COOLING

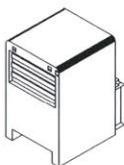

Dehumidifier

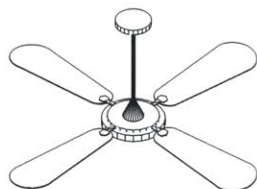

Ceiling Fan



Stand Fan

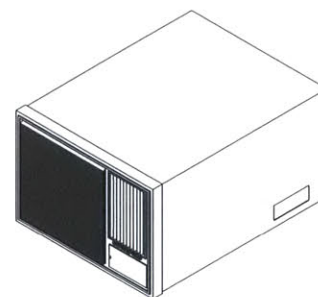

Air Conditioner

04 | **PROPOSAL** -- ATMOSPHERIC APPARATUS

THERMAE

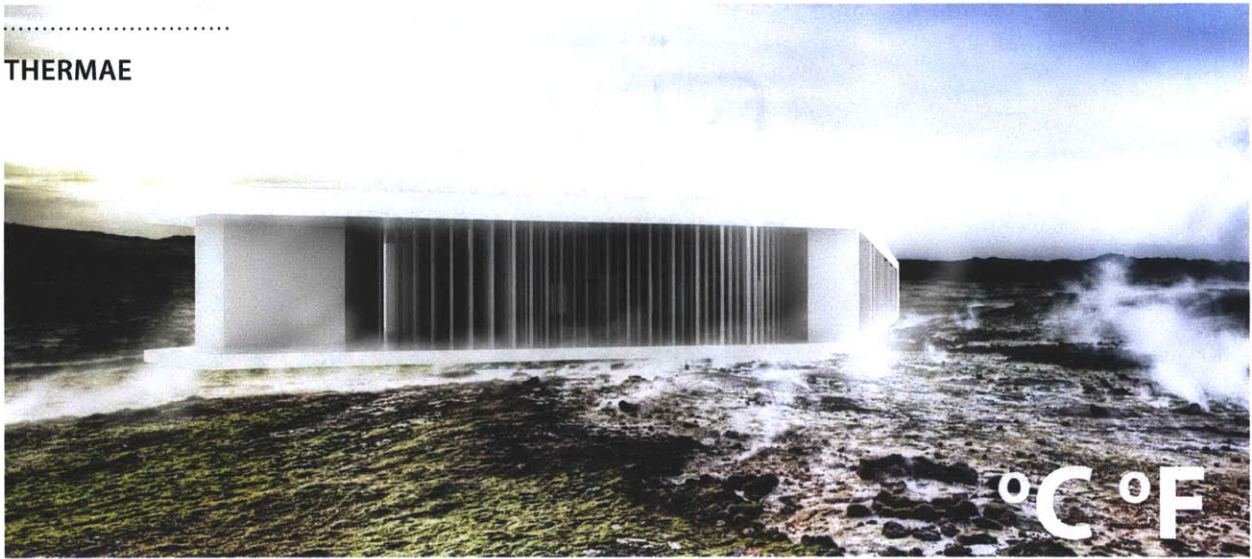

STRATUS

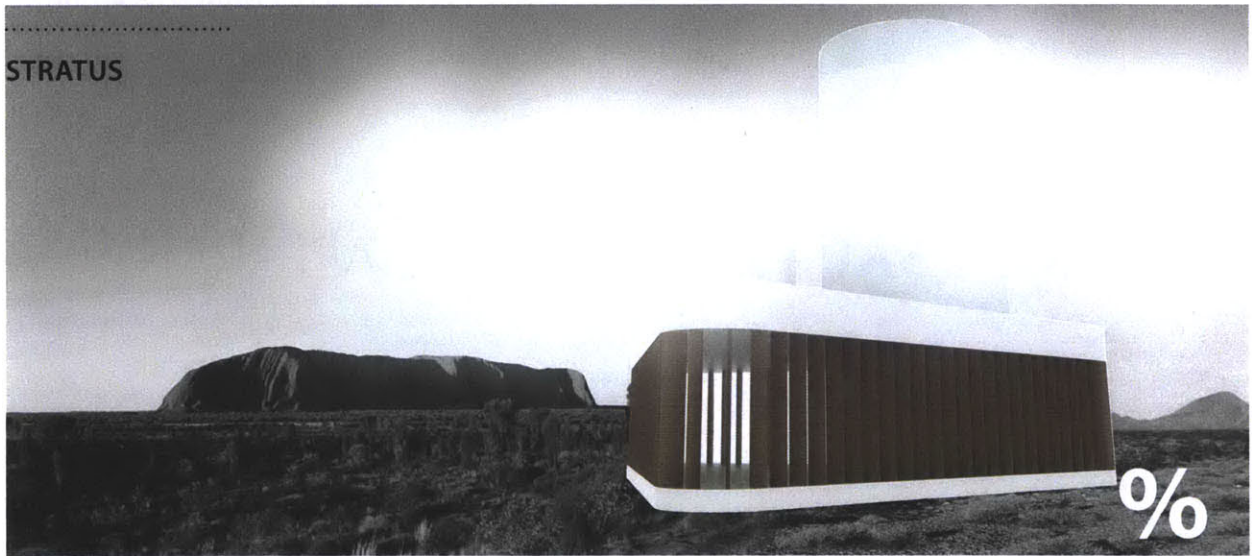

MONSOON



ATMOSPHERIC APPARATUS

THE PRODUCTION OF ANOTHER COMFORT PARADIGM

The architectural proposal of the thesis are three experimental prototypes of **Atmospheric Apparatus**. The major idea of three prototypes is to induce an alternative atmospheric experience for thermal comfort. Thus, each prototype's design is driven by a specific atmospheric factor and they are **Temperature | °C**, **Humidity | %** and **Wind | m/s** respectively. In addition to the atmospheric factors, the program, site location and material choices of each apparatus prototype are differently decided in order to further enhance the unique experiences.

OC

O F

SITE



ICELAND

CLIMATE

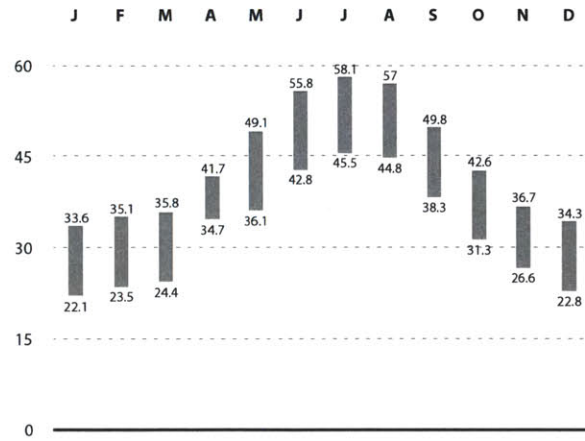

Average max. and min. temperature / °F
Source: Hong Kong Observatory

GEOHERMAL



Volcanic landscape

Image sources:

Left: <http://www.wallcoo.net>, Right: <http://www.evwind.es>

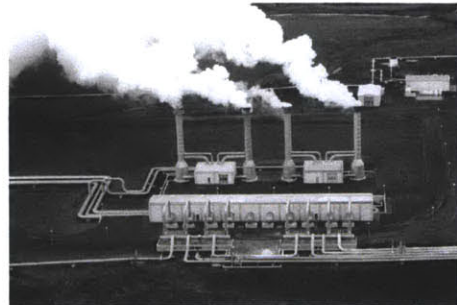

Geothermal power plant

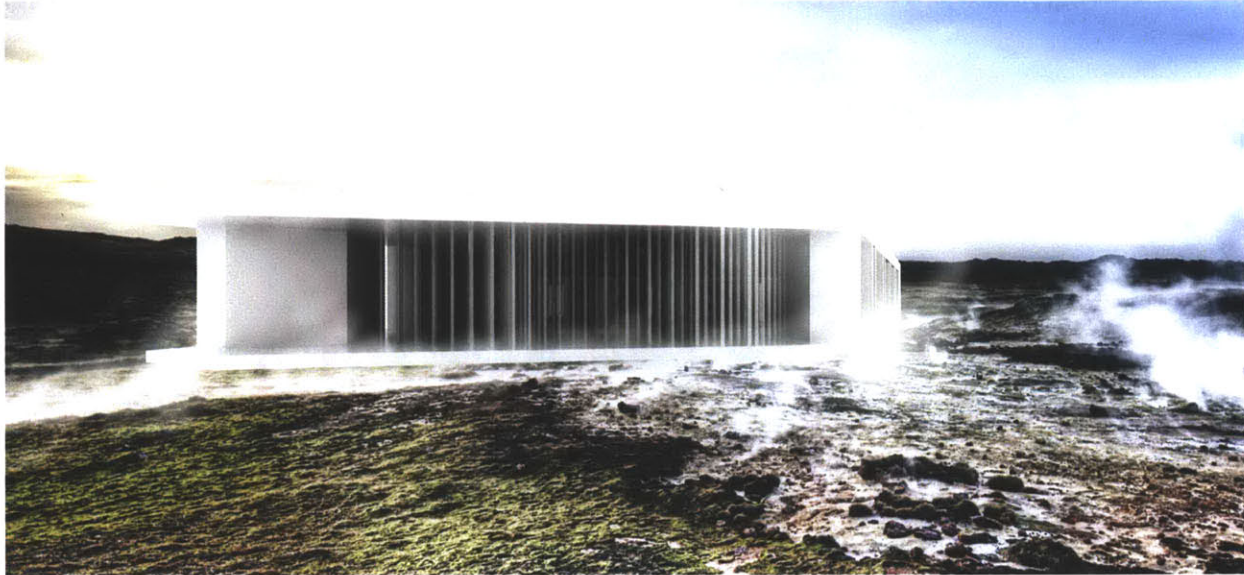

THERMAE

RE-EXPERIENCING TEMPERATURE

THERMAE is the first prototype designed to provide opportunity for re-experiencing the “forgotten” temperature. Nowadays, our living environment is constantly regulated with standard temperature level according to the pre-defined comfort zone derived from modern engineering knowledge. However, the pre-determined have been always proved to be not suitable for everyone’s comfort desire, Thus, THERMAE is designed as a device to produce a spectrum of diverse thermal experience.

Site and Climate⁵

Akureyri, a fishing town in the northern part of Iceland, has a subpolar oceanic climate of cold winter and mild summer. The average temperature of the region is relatively low throughout the year. The average maximum summer temperature is only 58.1 °F, while the average minimum winter temperature is 22.1 °F.

Resource

Due to Iceland’s geological condition, the abundance geothermal power resources from below ground become the major energy source for the country. In 2010, 26.2% of the nation’s energy is generated by the geothermal power, and 87% of the heating and hot water supply are produced by the geothermal heat source.⁶ Therefore, THERMAE will take advantage of this abundance resources to generate another thermal experience.

5. Akureyri, Wikipeda Retrived Jan 13, 2013 <http://en.wikipedia.org/wiki/Akureyri>

6. Landsvirkjun Power Station Retrived Jan 13, 2013 <http://www.landsvirkjun.com/Company/PowerStations/>

MECHANISMS

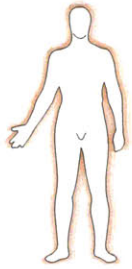

Radiation

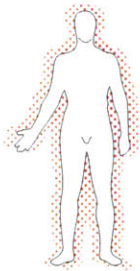

Convection

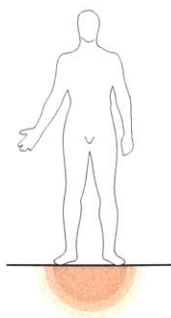

Conduction

MEDIA

SURFACE

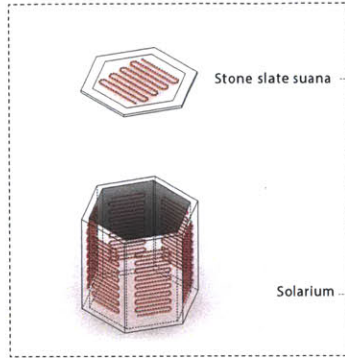

AIR

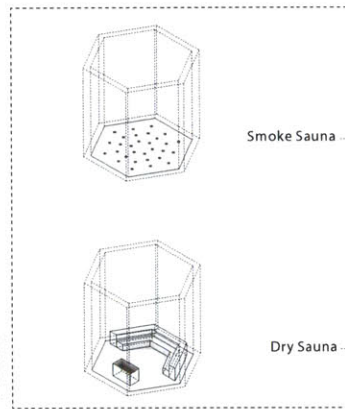

WATER

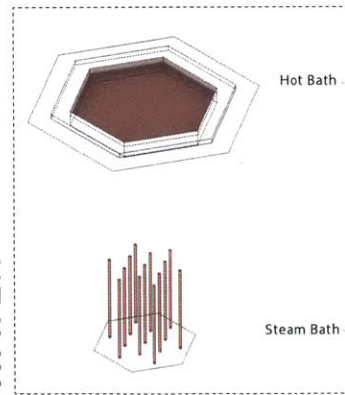

THERMAL EXPERIENCES

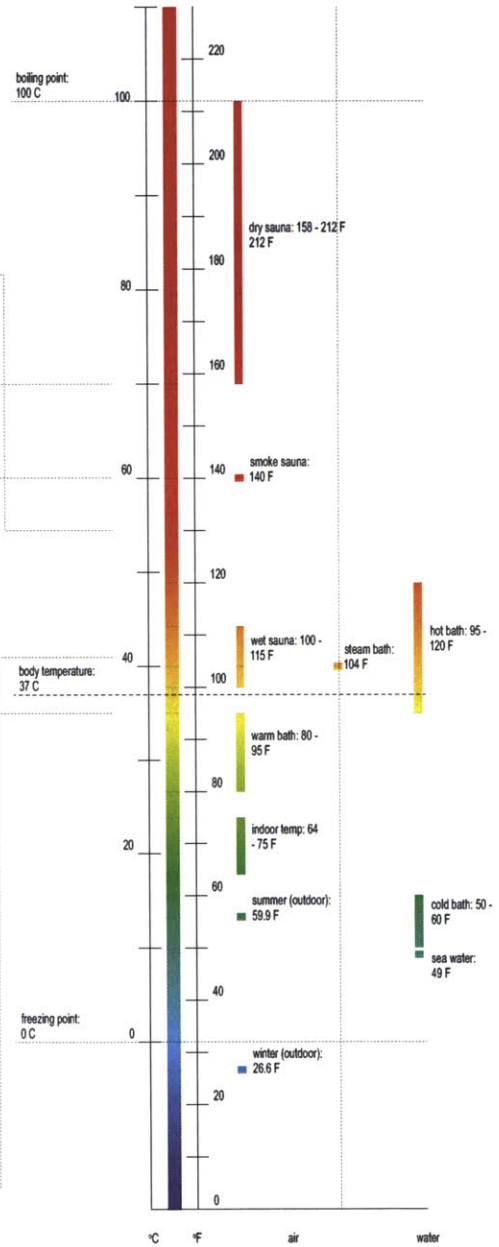

THERMAL MAP

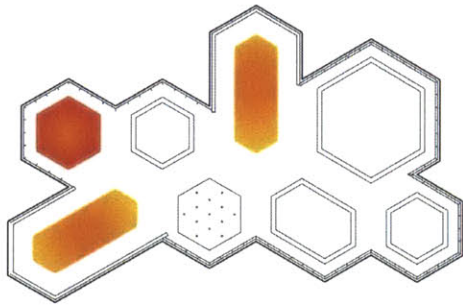

Surface - Radiation

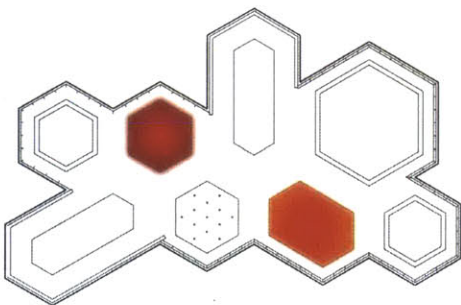

Air - Convection

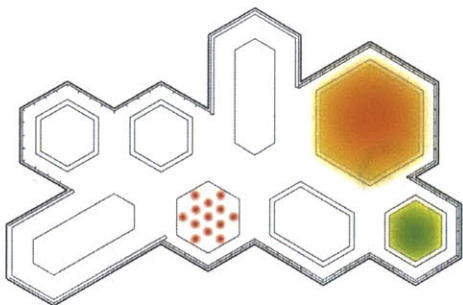

Water - Conduction

Program

The programmatic idea of THERMAE is to produce rich and diverse thermal experiences through various heat exchange mechanisms: **radiation**, **convection** and **conduction**. These heat exchange mechanisms will occur between the human body with specific experience media of surface, air and water respectively.

Radiation

The radiation process occurs through heated surfaces with hot water hydronic tubes embedded. They are the stone sauna with a single flat stone slate surface and the solarium with six surfaces inside an enclosed chamber.

Convection

While another thermal experience is obtained through the convection process by passing heated air over the body in dry sauna and smoke sauna. Because of difference in air heating methods, the experienced air temperature in dry sauna is higher than the smoke sauna one.

Conduction

Lastly, the conduction process happens when the body is in direct contact to the warm water in the hot bath, cooled water in cool shower and steam vapor in the steam bath. Due to the direct body contact, the temperature of the thermal experience will be relatively lower.

THERMAL MAP

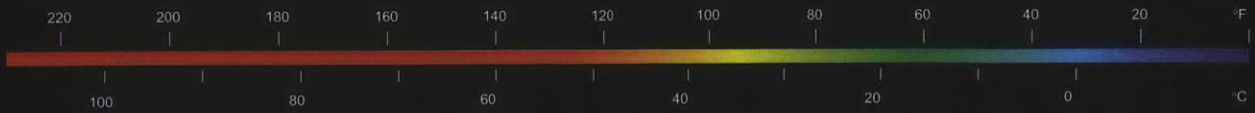
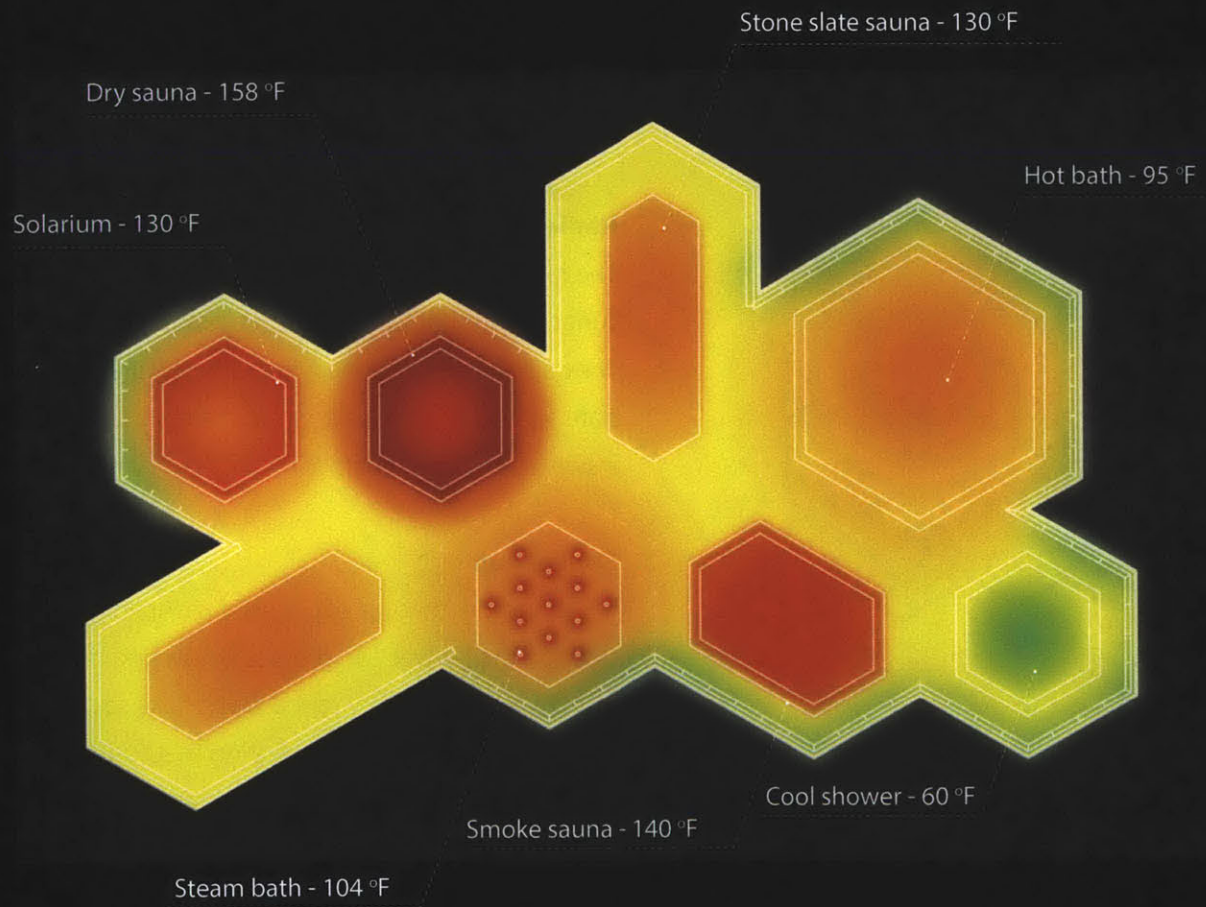

.....
FLOOR PLANS

- 1. Solarium
- 2. Dry sauna
- 3. Stone slate sauna
- 4. Hot bath
- 5. Steam bath
- 6. Smoke sauna
- 7. Cool shower

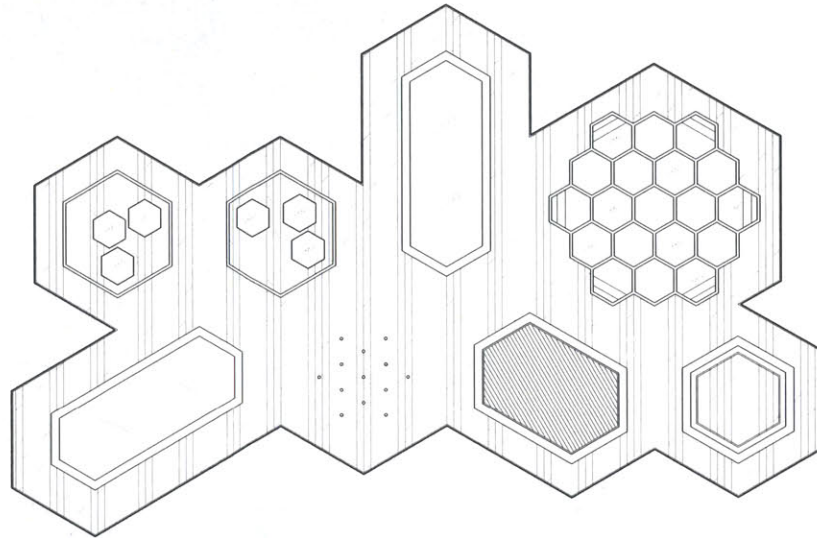

Roof plan

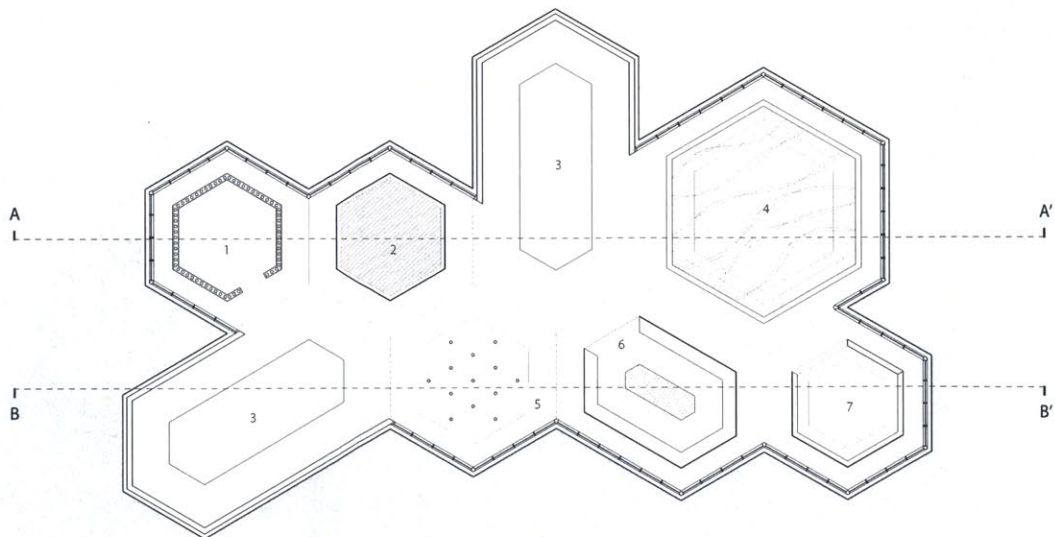

Ground plan

AXONOMETRIC
DRAWING

ROOF

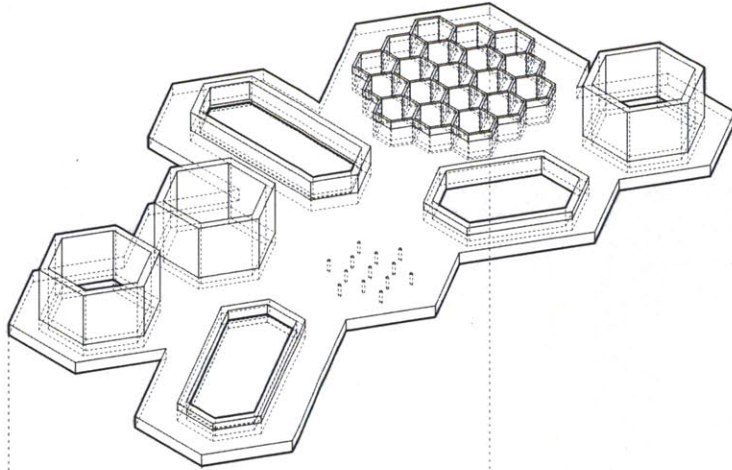

ELEMENTS

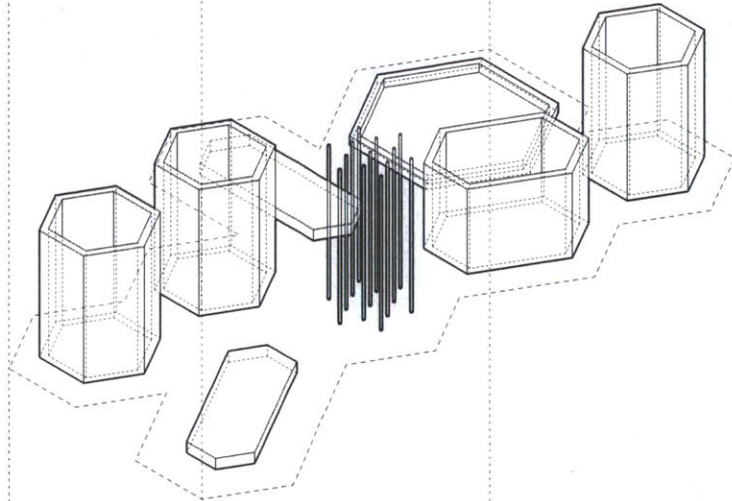

SPACE

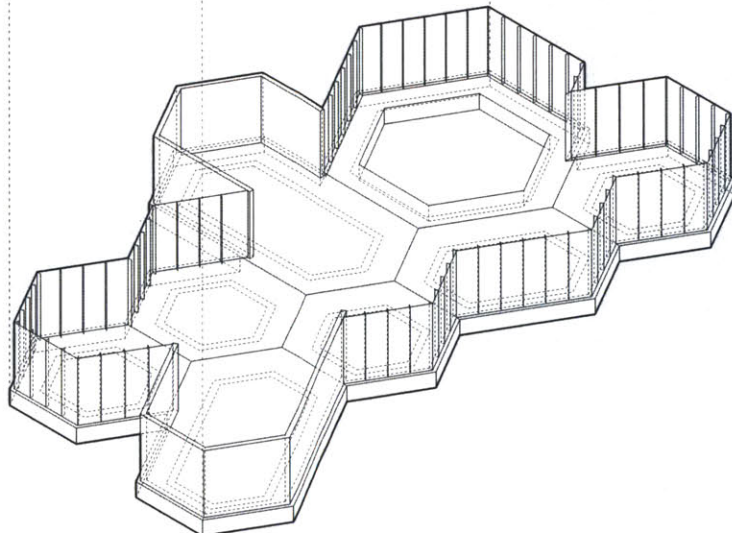

.....

SECTIONS

- 1. Solarium
- 2. Dry sauna
- 3. Stone slate sauna
- 4. Hot bath
- 5. Steam bath
- 6. Smoke sauna
- 7. Cool shower

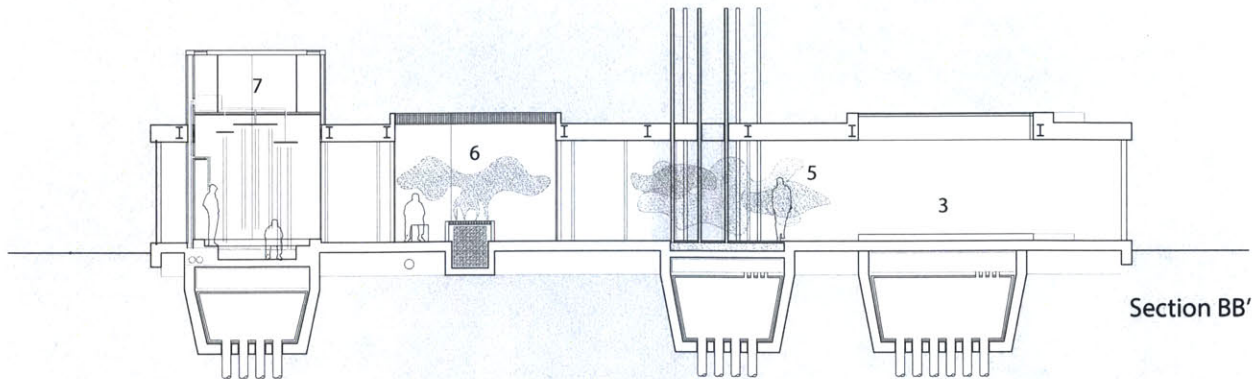
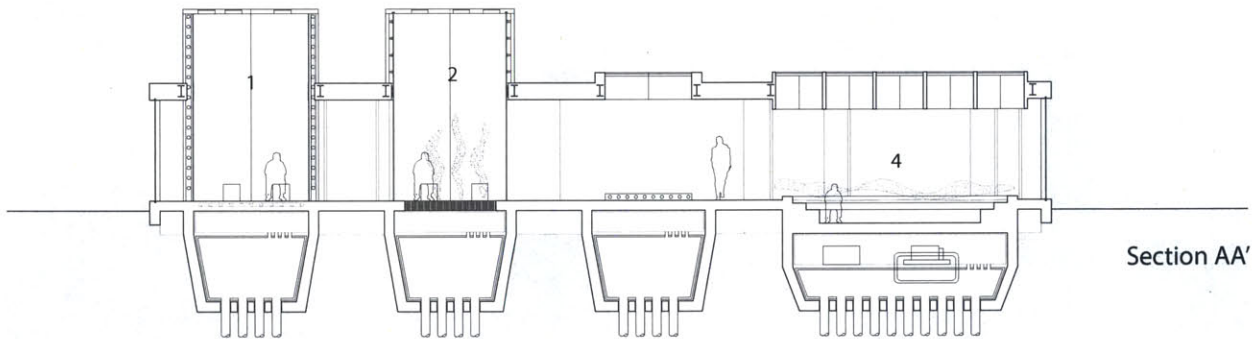

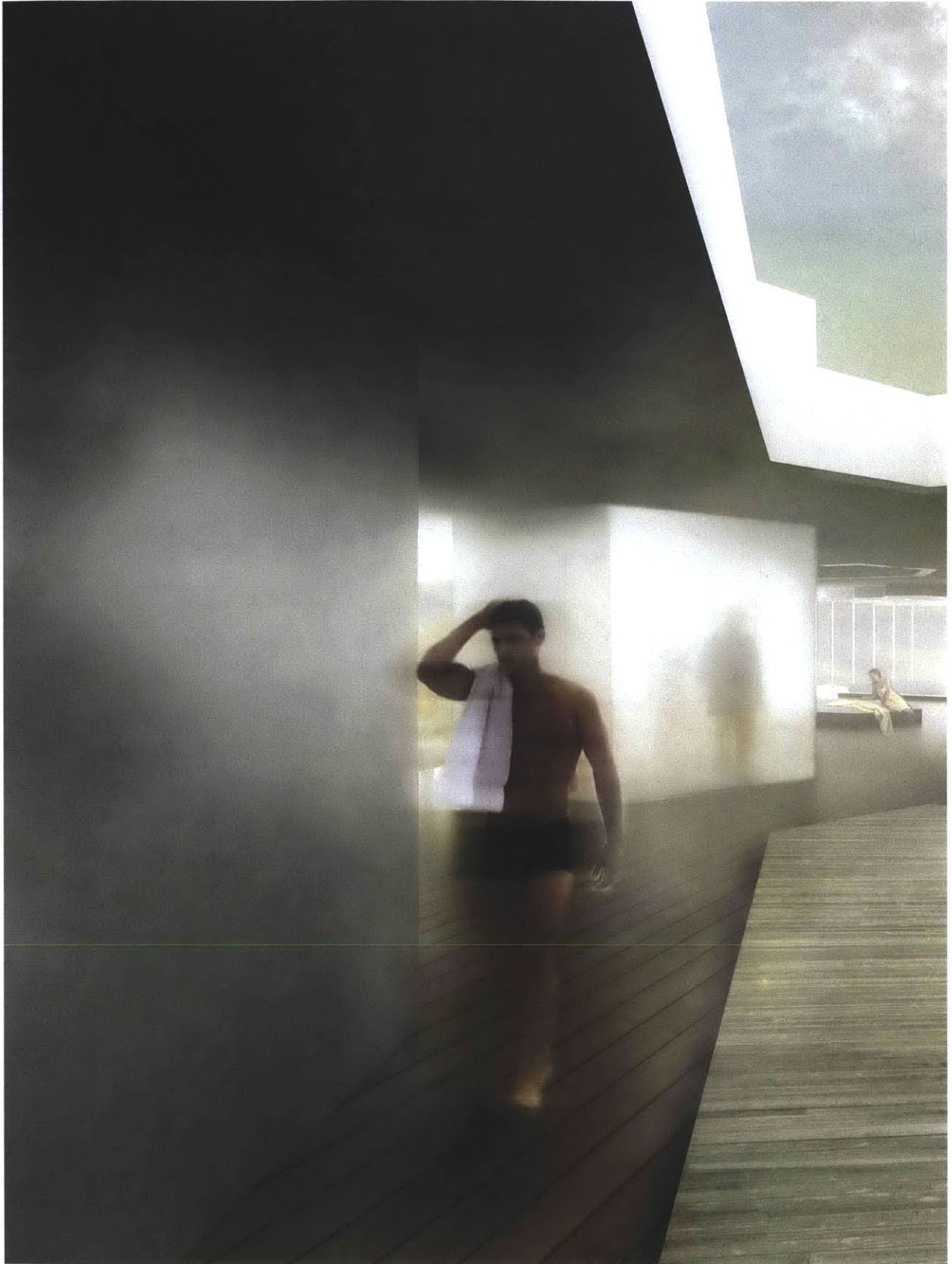







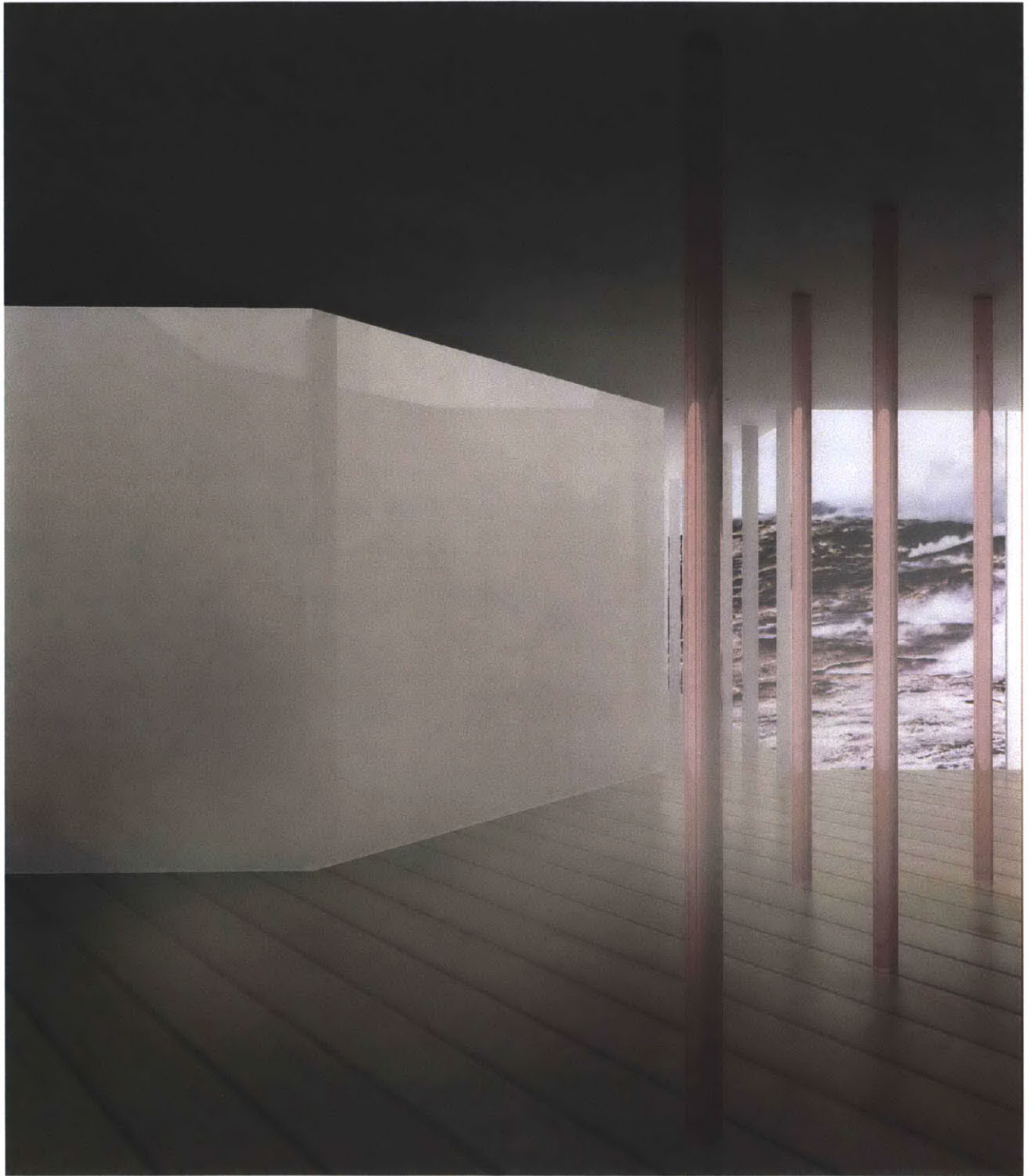



.....
MODEL ARCHIVE

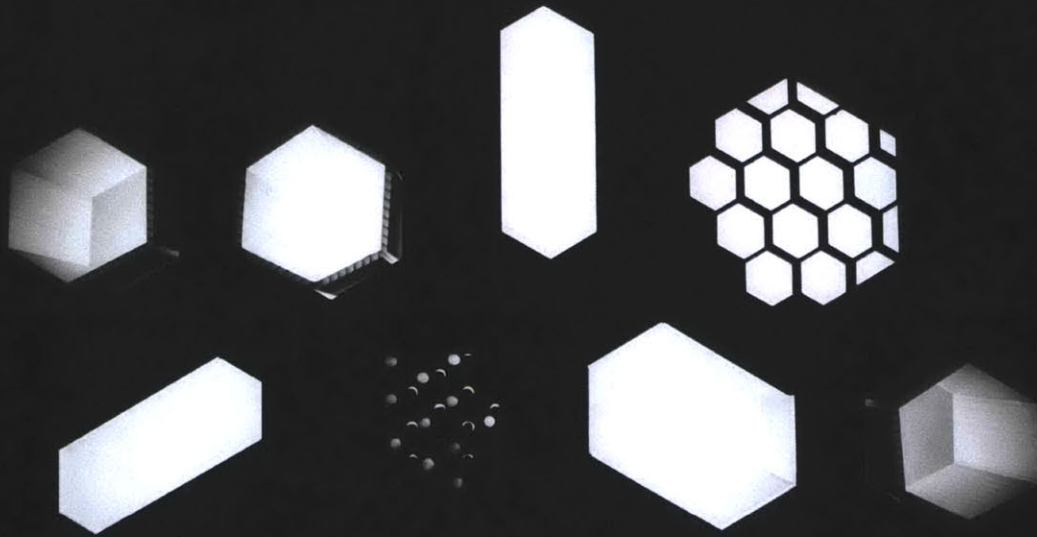

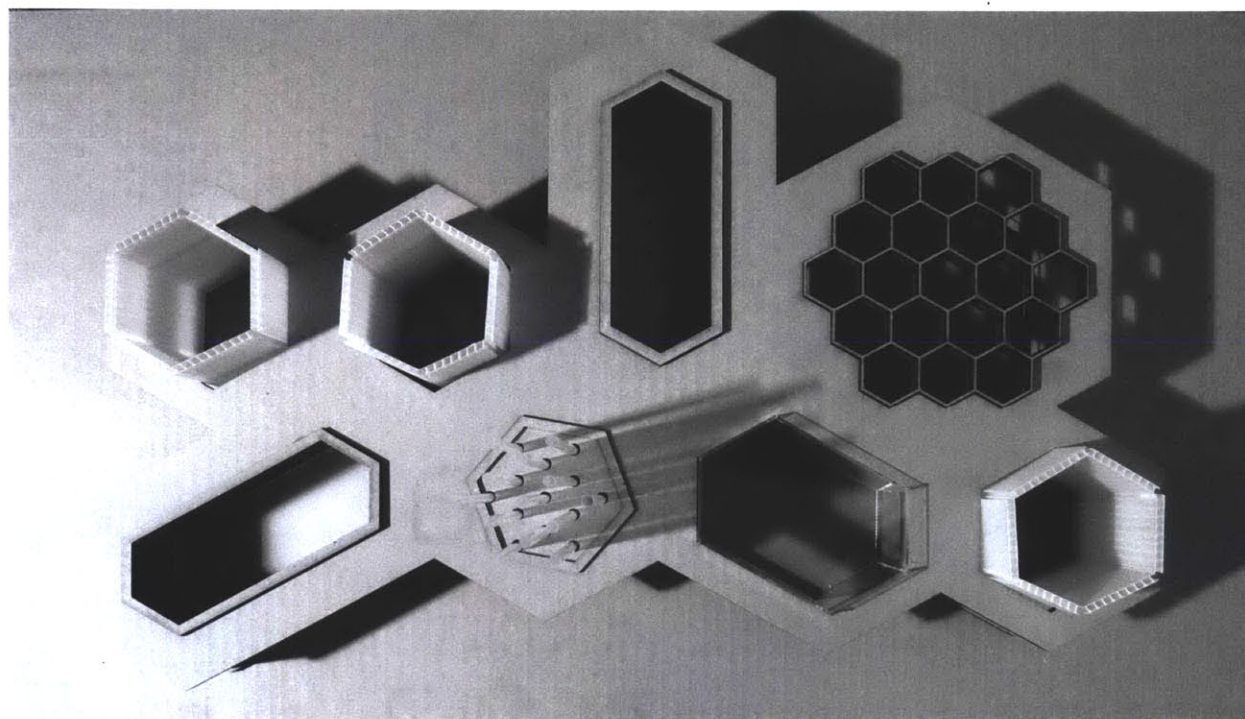

MODEL ARCHIVE

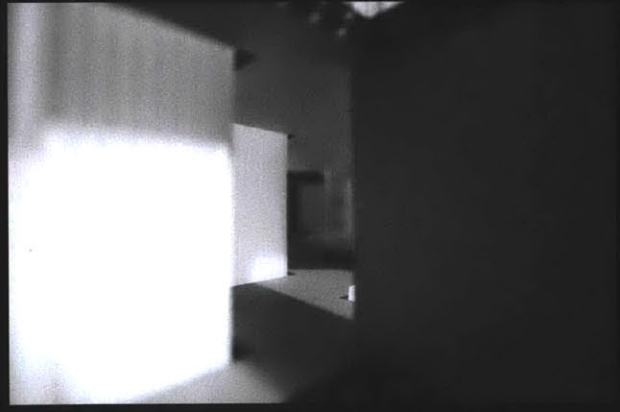
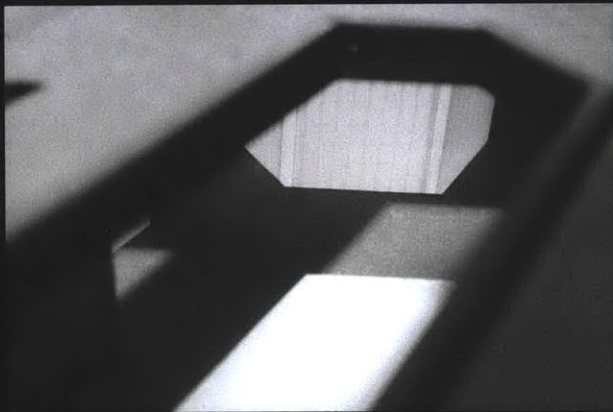
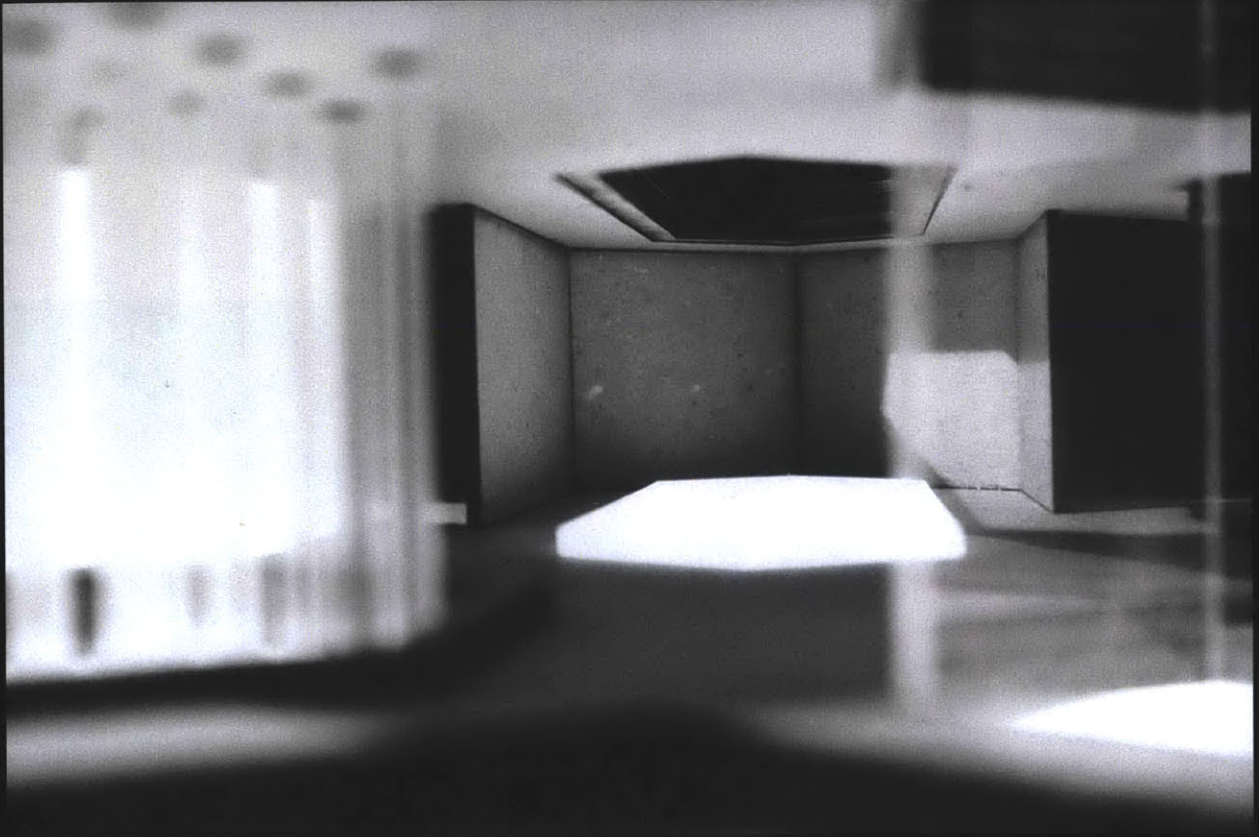

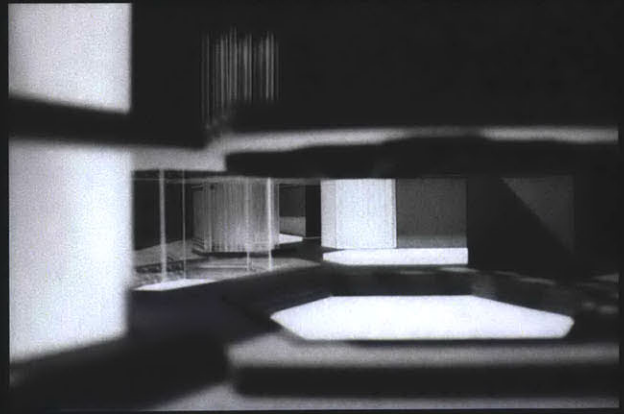
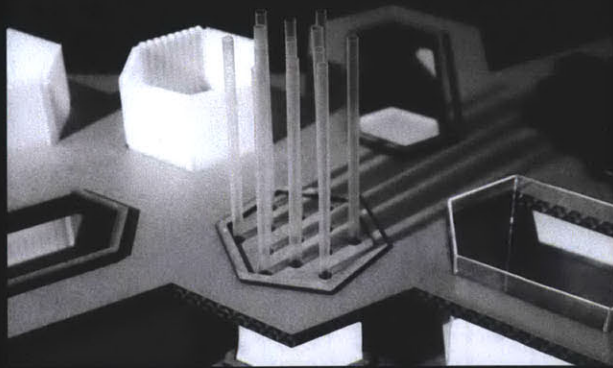
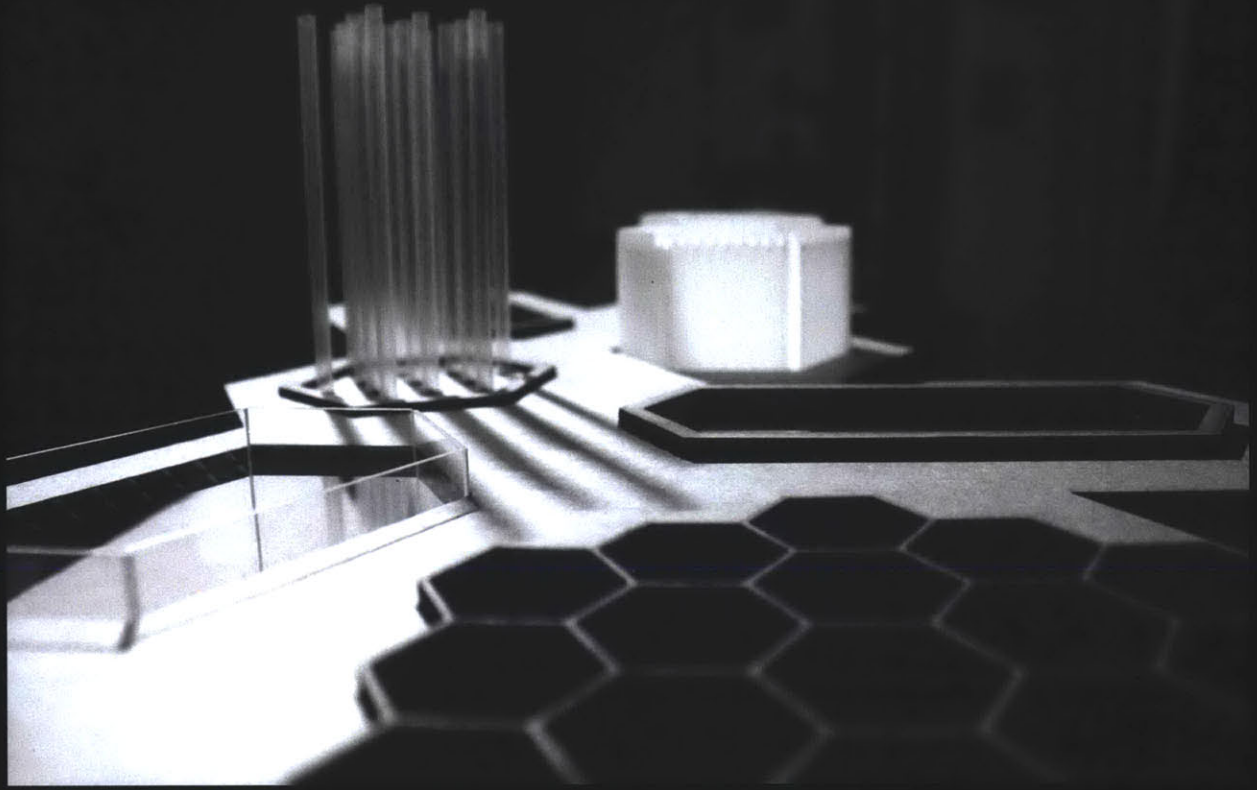

0%

0%

SITE

• ALICE SPRING

AUSTRALIA

CLIMATE

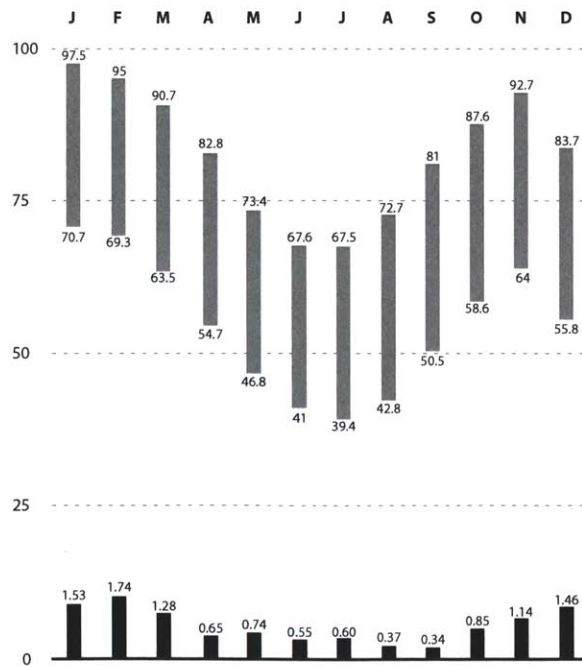

Above: Average max. and min. temperature / °F

Below: Rainfall / mm

Source: Australian Bureau of Meteorology

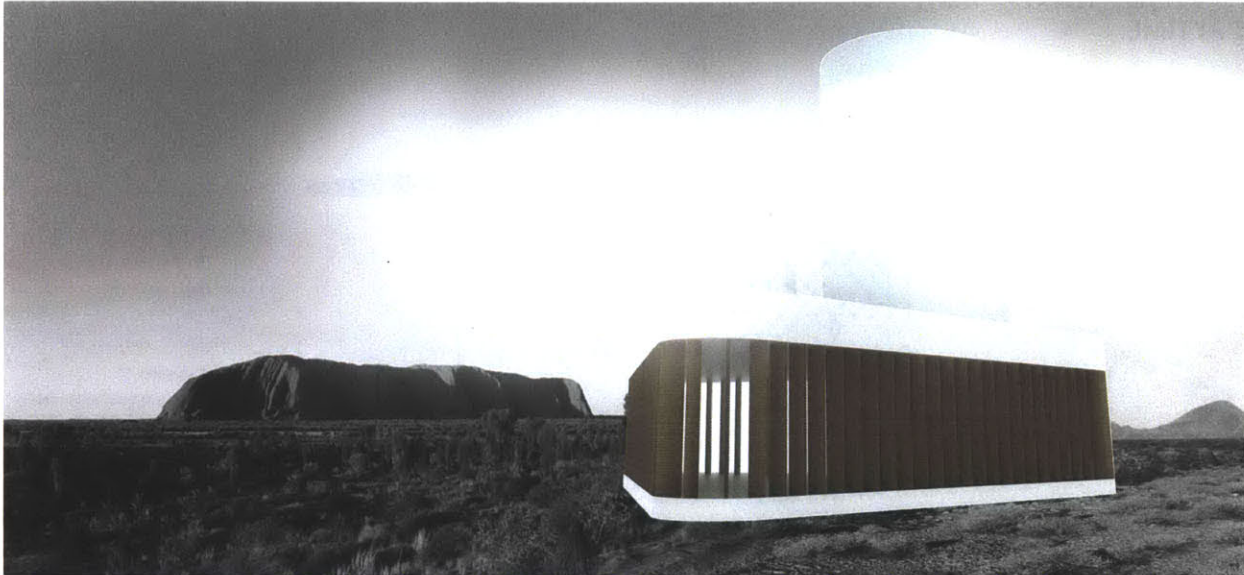

STRATUS

RE-EXPERIENCING HUMIDITY

In addition to temperature, the atmospheric humidity also plays an important role to induce comfort thermal experience. Thus, **STRATUS**, the second apparatus prototype, is designed to articulate the presence of humidity within the atmosphere for comfort. At the same time, the **STRATUS** will help to recall the human sensation of the importance of humidity.

Site and Climate

Alice Springs locates in the center of Australia, where it situates within an arid area surrounded by several deserts. Due to its inland location, Alice Spring has hot and dry desert climate with relatively high temperature throughout the year, the limited annual average rainfall of 285.9 mm⁷ and high evapotranspiration rate prohibit any cloud formation to prevent excessive solar radiation gain during daytime and heat loss during nighttime, therefore, the area also suffers from dramatic diurnal temperature variation everyday.

⁷ Alice Springs, Wikipedia, http://en.wikipedia.org/wiki/Alice_Springs Retrieved 01.23.2013

DAYTIME

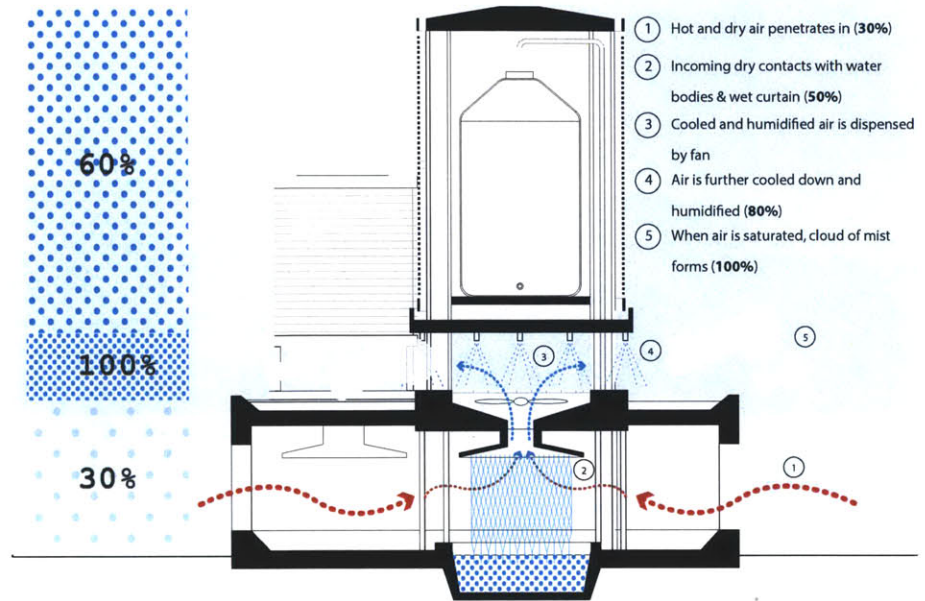

NIGHT-TIME

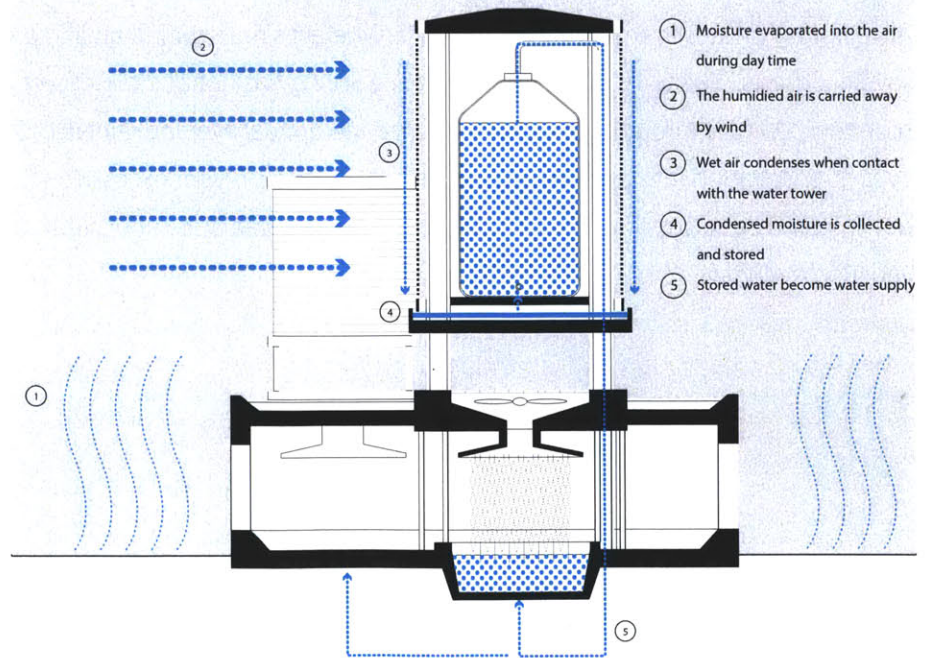

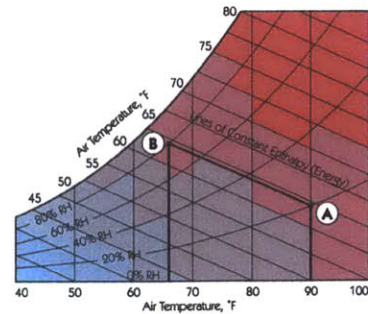
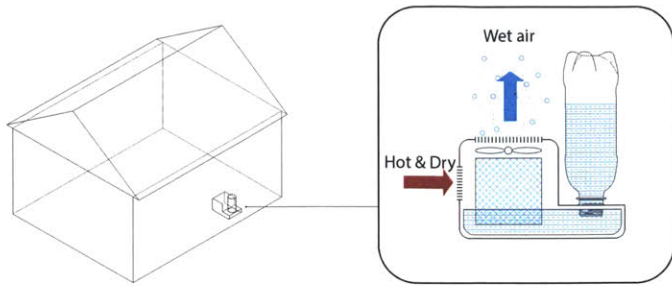

Source: Australian Bureau of Meteorology

ATMOSPHERIC APPARATUS

The design ambition of STRATUS is to produce an ecological apparatus with multiple functions in order to create a unique comfort experience related to humidity. Thus, in order to reflect this intention, the programmatic idea of STRATUS is decided to be water related, a water storage, water supply center, water collector and air humidifier are the primary programmatic framework for the design of STRATUS. The major goal of STRATUS is to induce decent comfort experience through the water related programs to achieve cooling effect. Actually, the Ultimate aspiration of STRATUS is to transform the perception of the place by mimicking the cloud formation to create a new atmospheric condition for the area.

.....
FLOOR PLANS

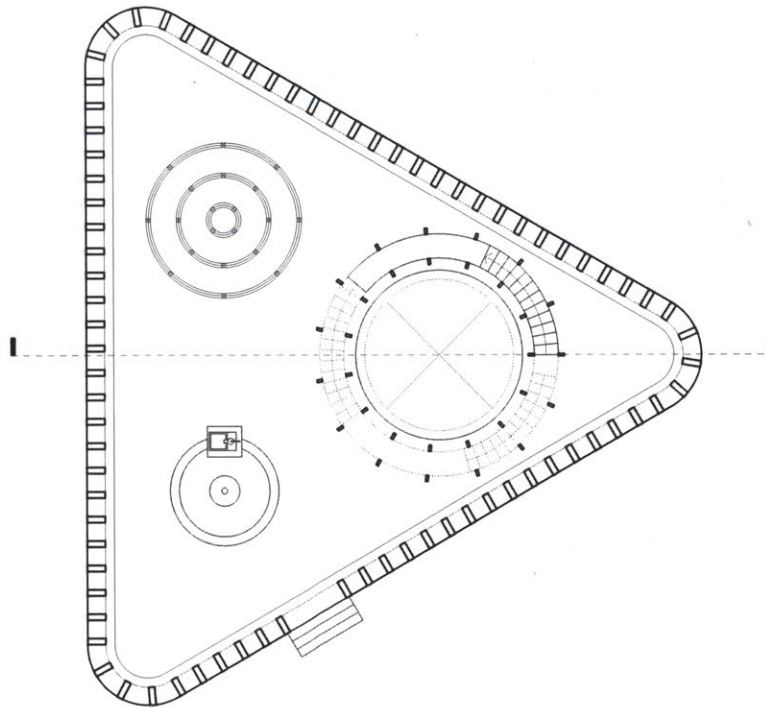
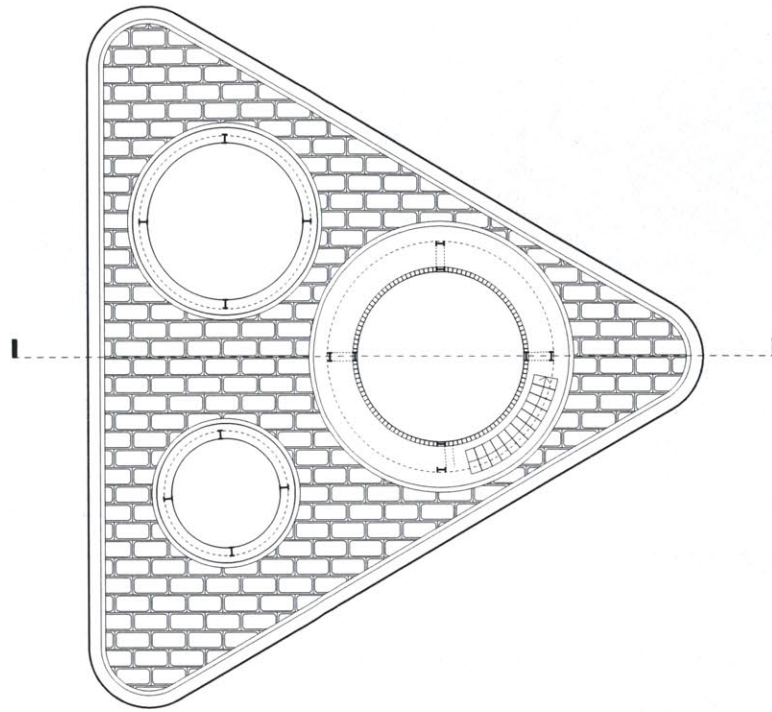

.....

SECTIONS

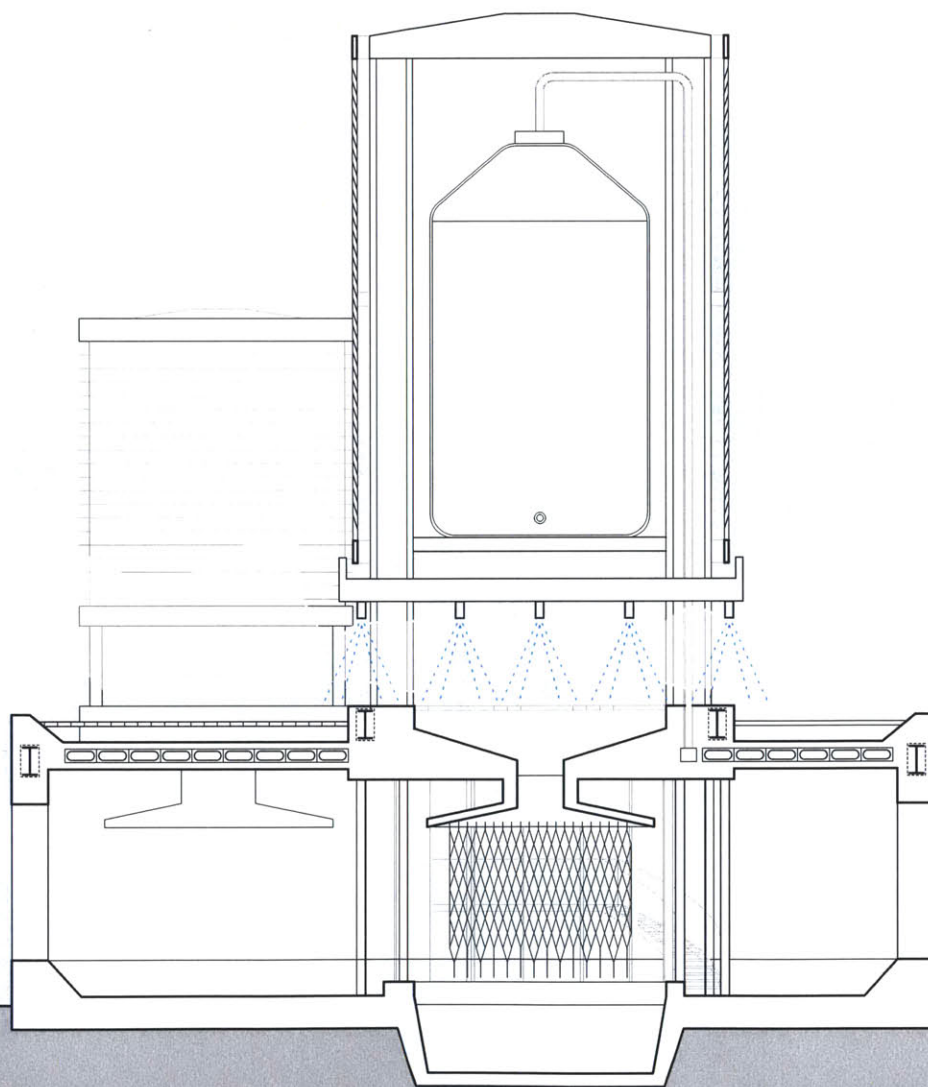

.....

AXONOMETRIC
DRAWING

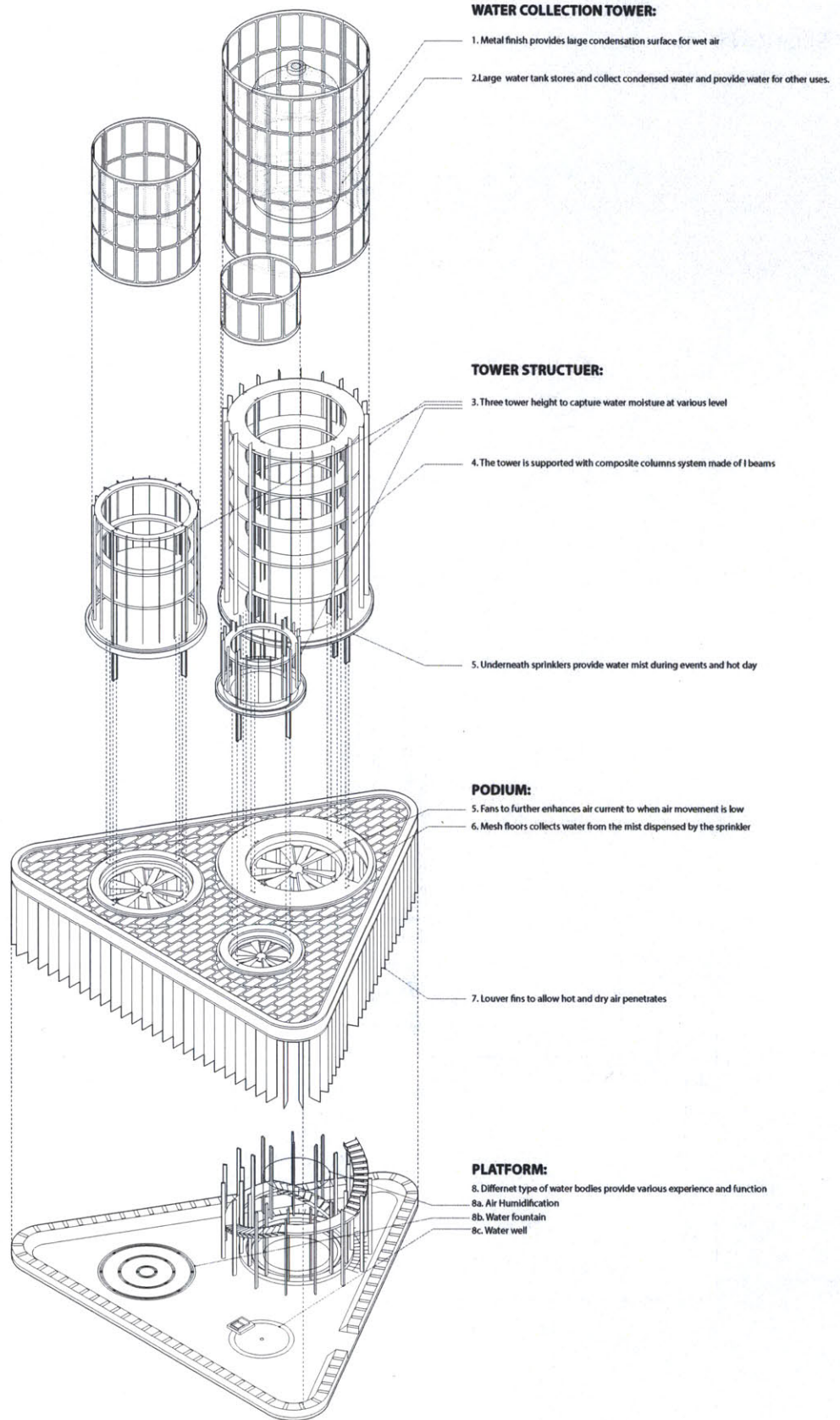

COMPONENTS

STRATUS is basically constituted of three major components: tower, podium and platform, which enables STRATUS to perform as a ecological apparatus at respective levels.

Water Collection Tower:

The superstructure of STRATUS is dominated by three water collecting tower with various height. The major function of these tower is to provide sufficient cooling surfaces are for air moisture condensation happens during the nighttime. Due to the high thermal conductive property of the surface material, the tower will have lower temperature than the atmospheric air, thus, condensation occurs when the hot air moisture is in direct contact with the surfaces. Moreover, the different tower heights provide enough exposure to each tower for a non-obscured air current. Meanwhile, a water tank is installed withing the taller tower for water collection purpose.

Podium:

The podium of STRATUS provides an decent outdoor space with the aids of the sprinklers system to regulate the humidity level to a comfortable level. During daytime, the sprinkler system will dispense cloud of mist to induce cooling effect for the air, while the mist clouds can reduce radiant temperature by blocking some solar radiation from heating up the surface. As a combine effect of cooling effect and radiation reduction, the podium become a decent outdoor event space even during the hot and arid day at Alice Spring.

Platform:

The platform of STRATUS accommodates mainly the water center program to serve as a public facility and community gathering space for people who come here for water. The covered interior provides shaded to protect from the direct solar radiation of heating up. The interior experience is also further enhanced by the present of water bodies and good ventilation by openness of the peripheral supporting structure.

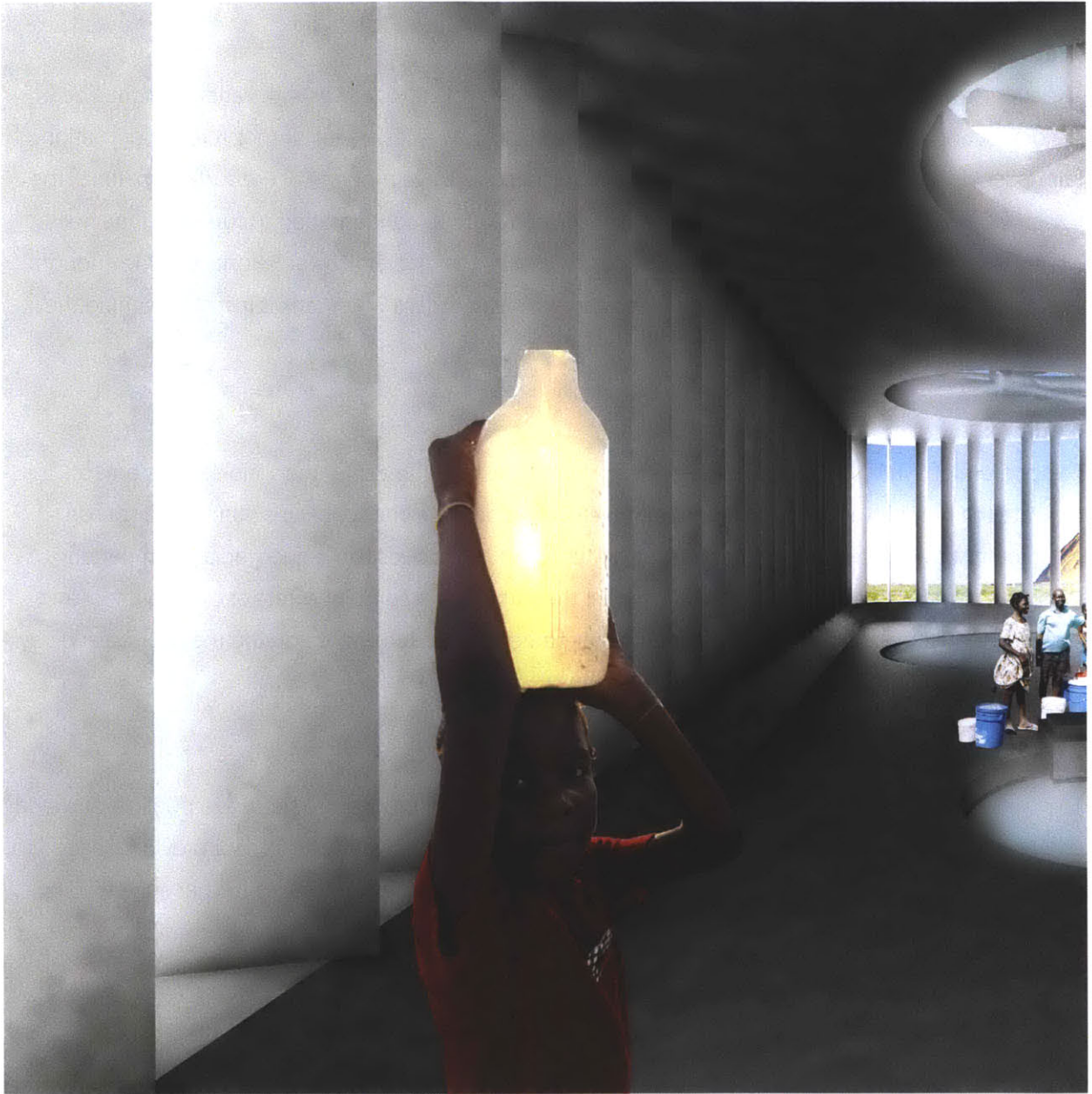

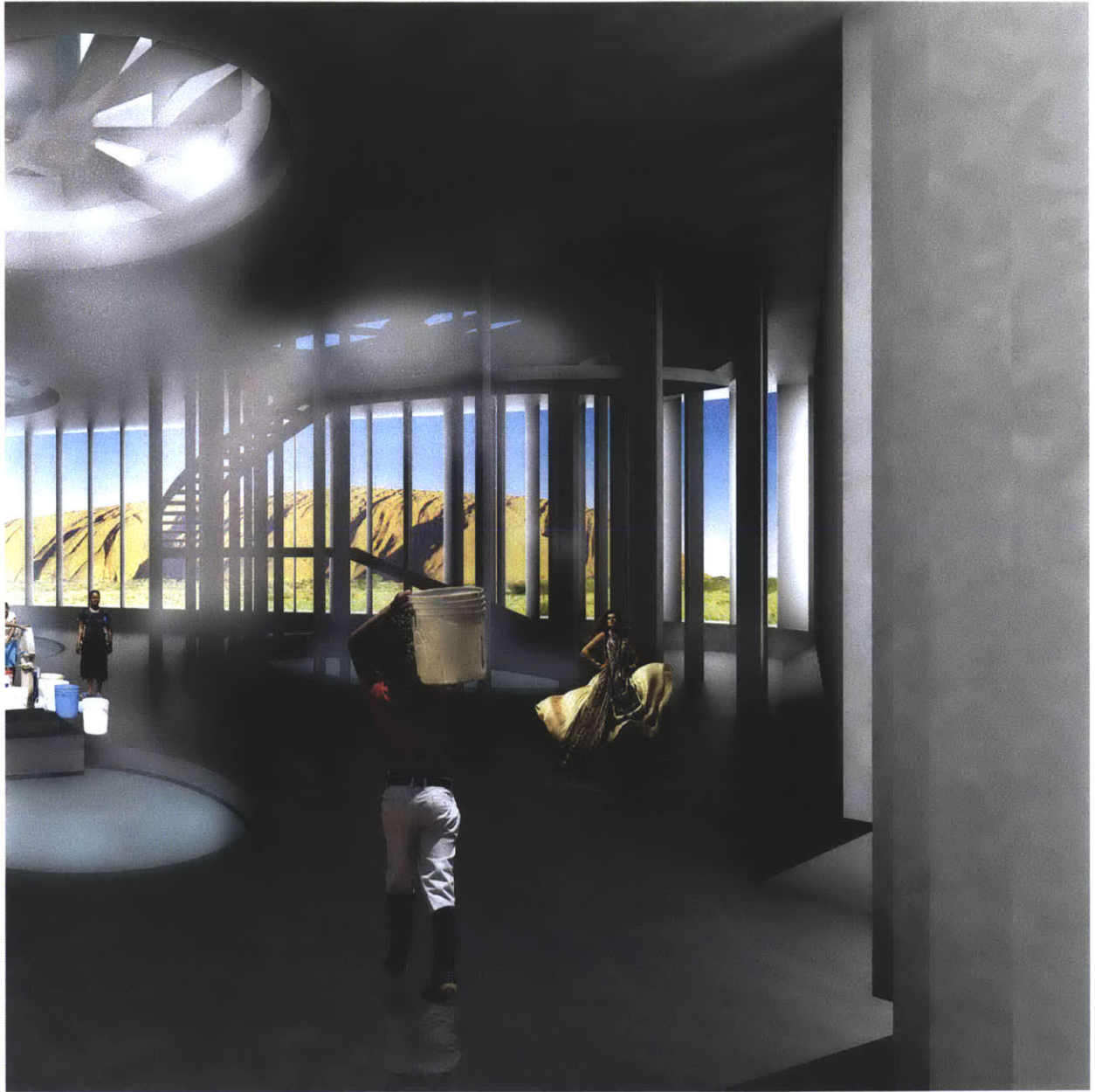

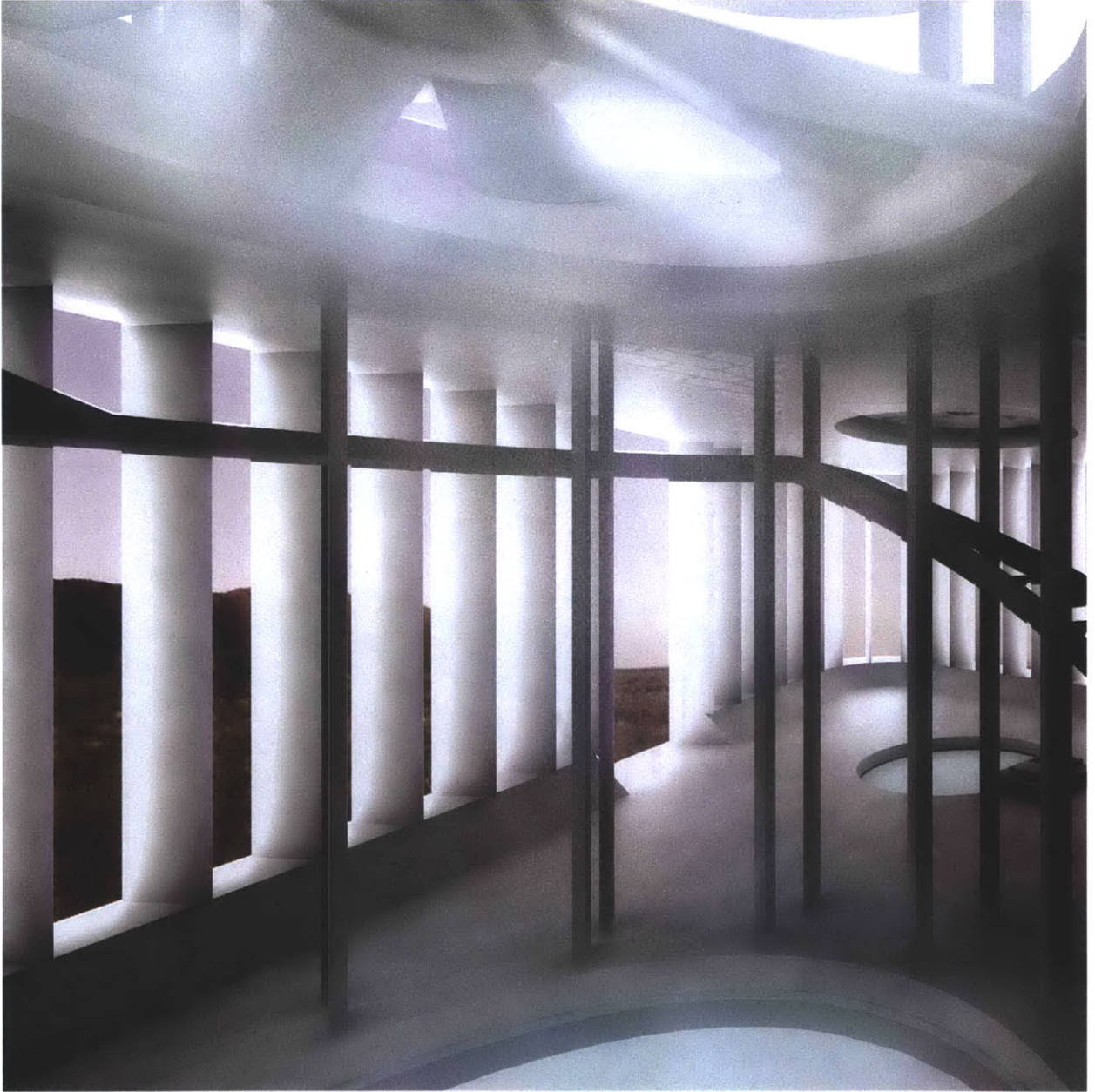



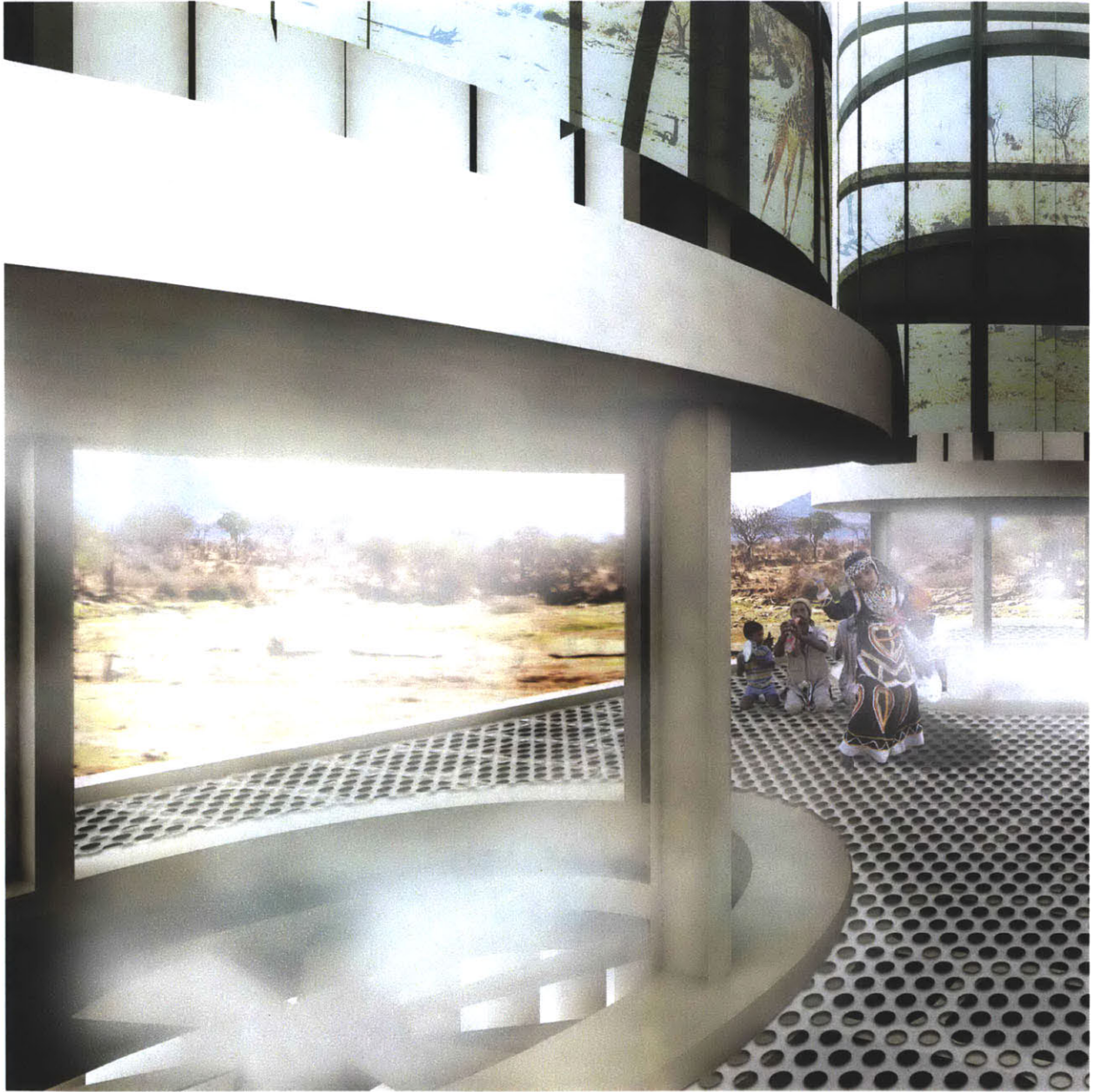



MODEL ARCHIVE

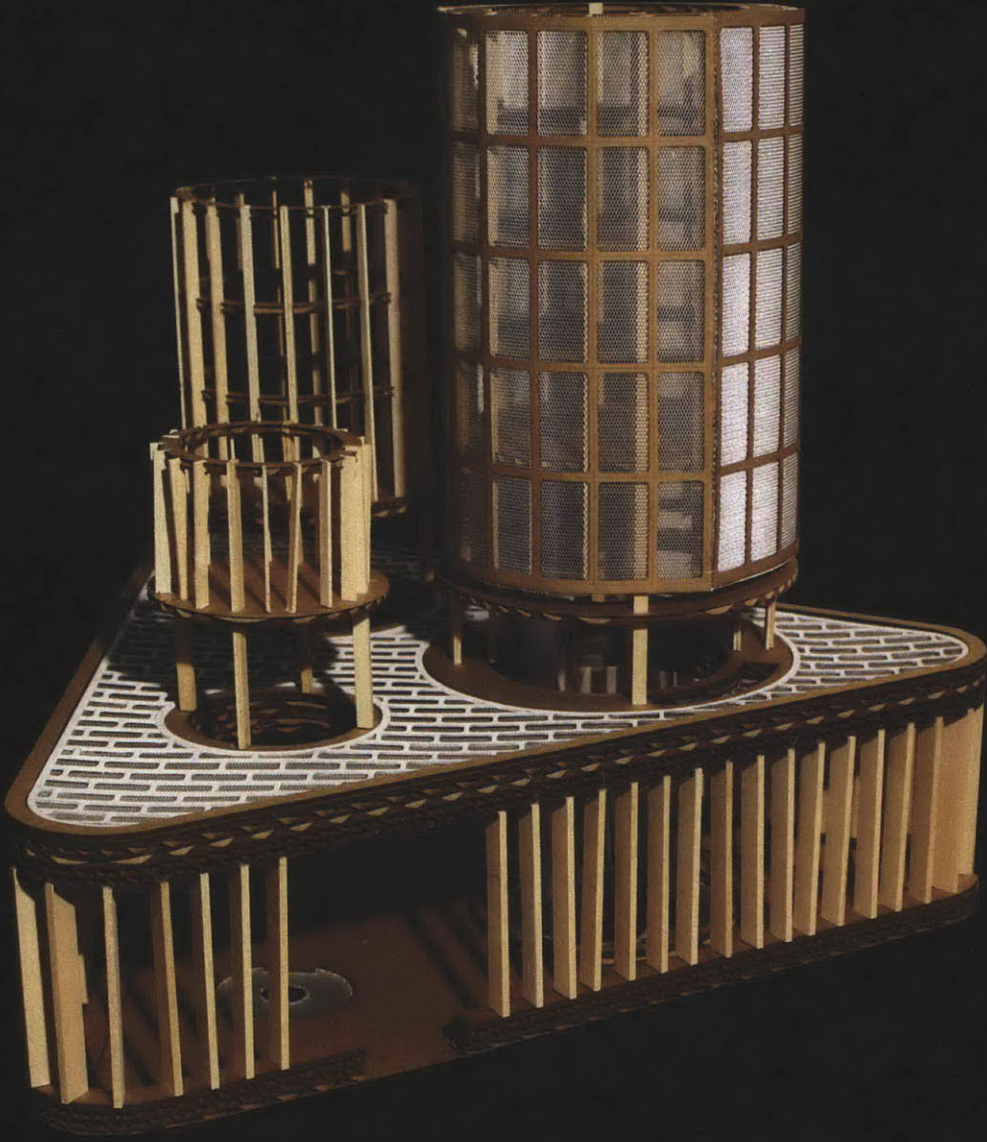



MODEL ARCHIVE

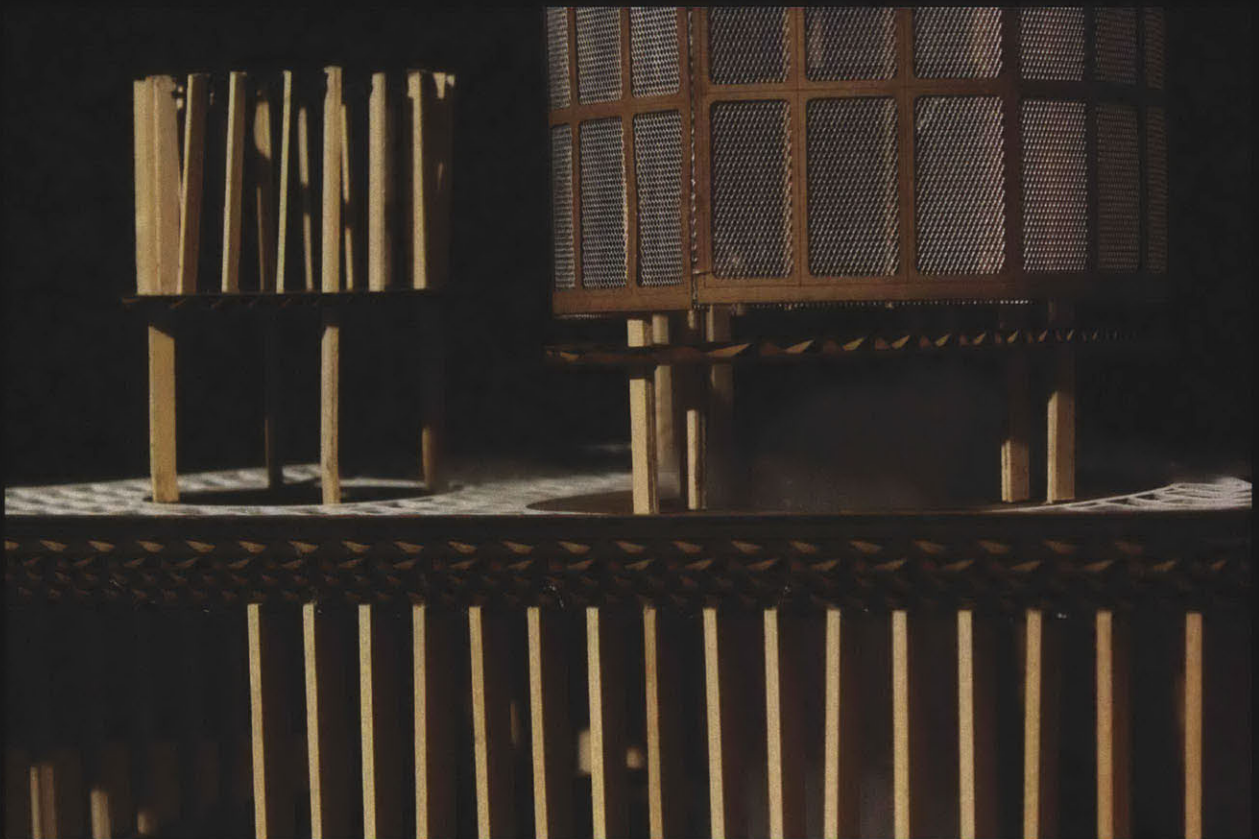

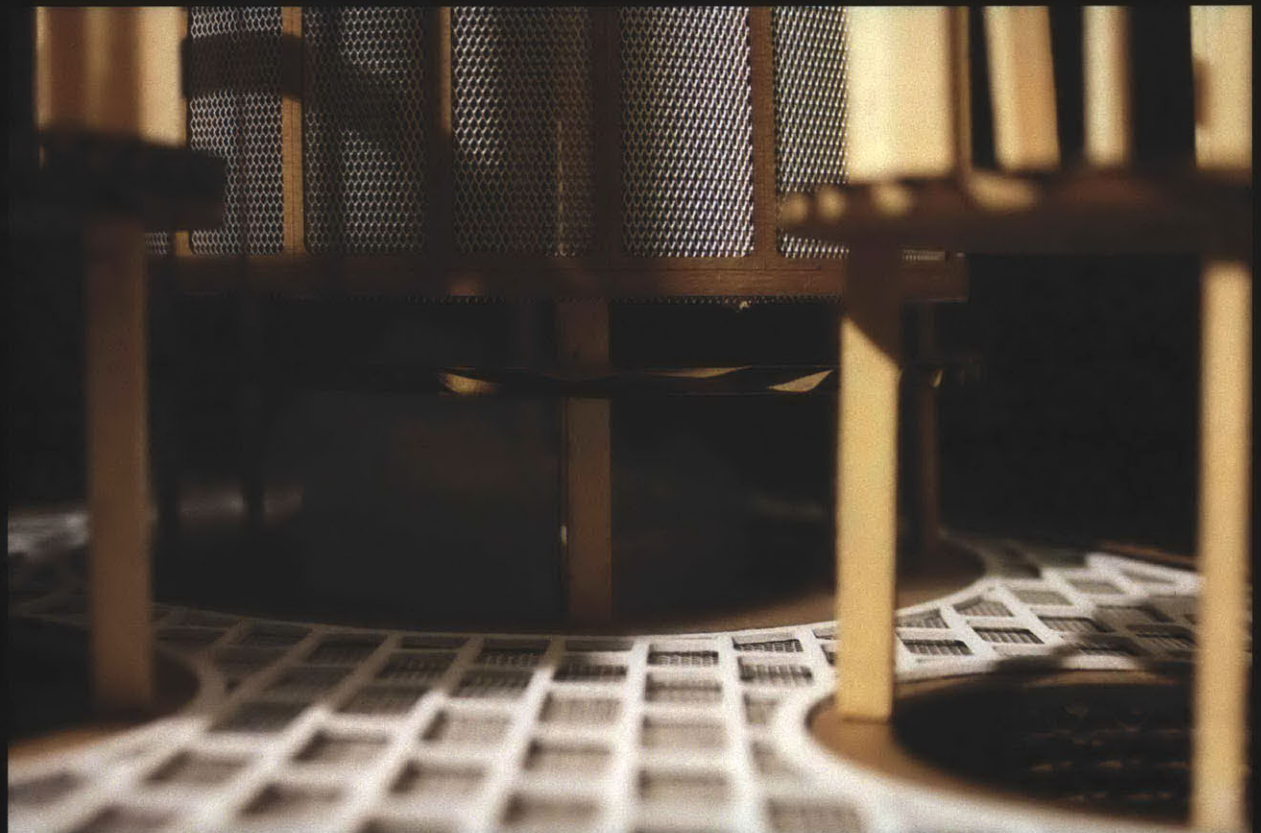
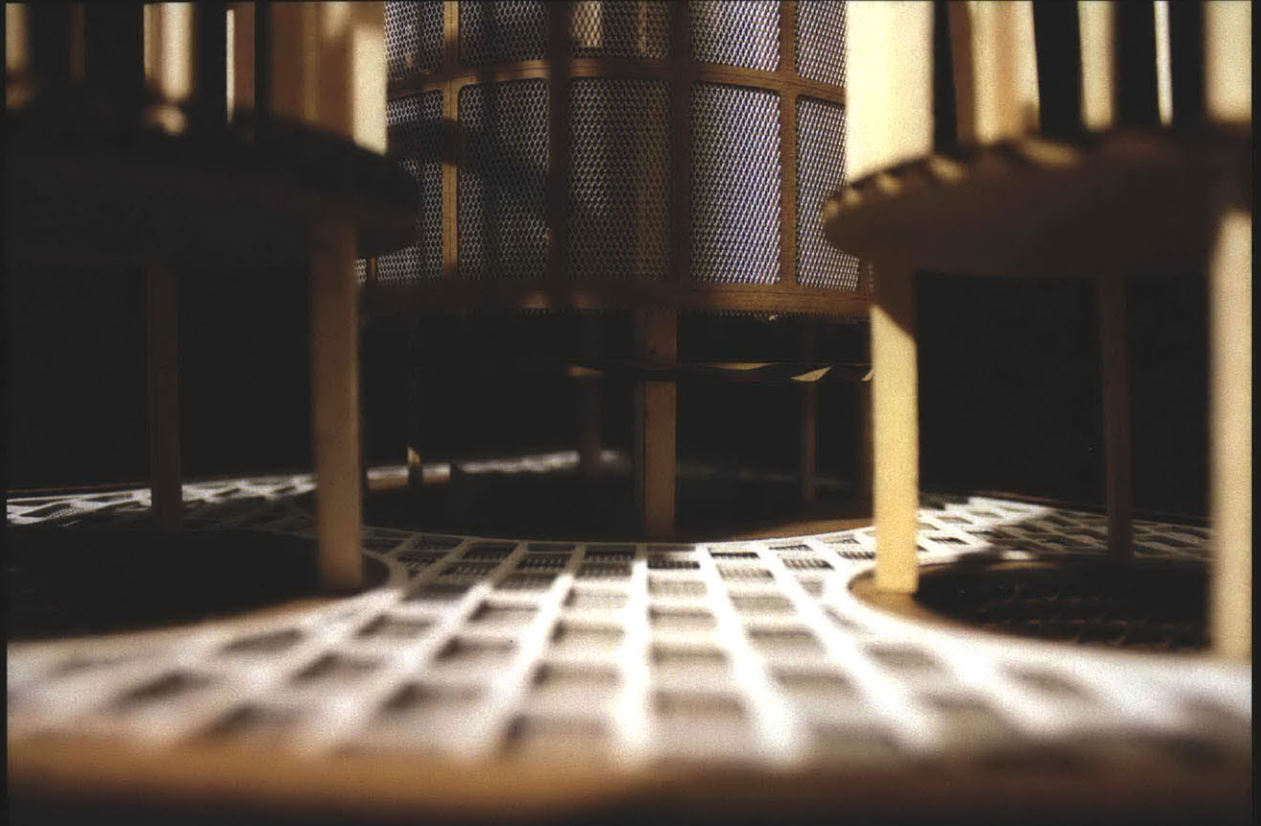

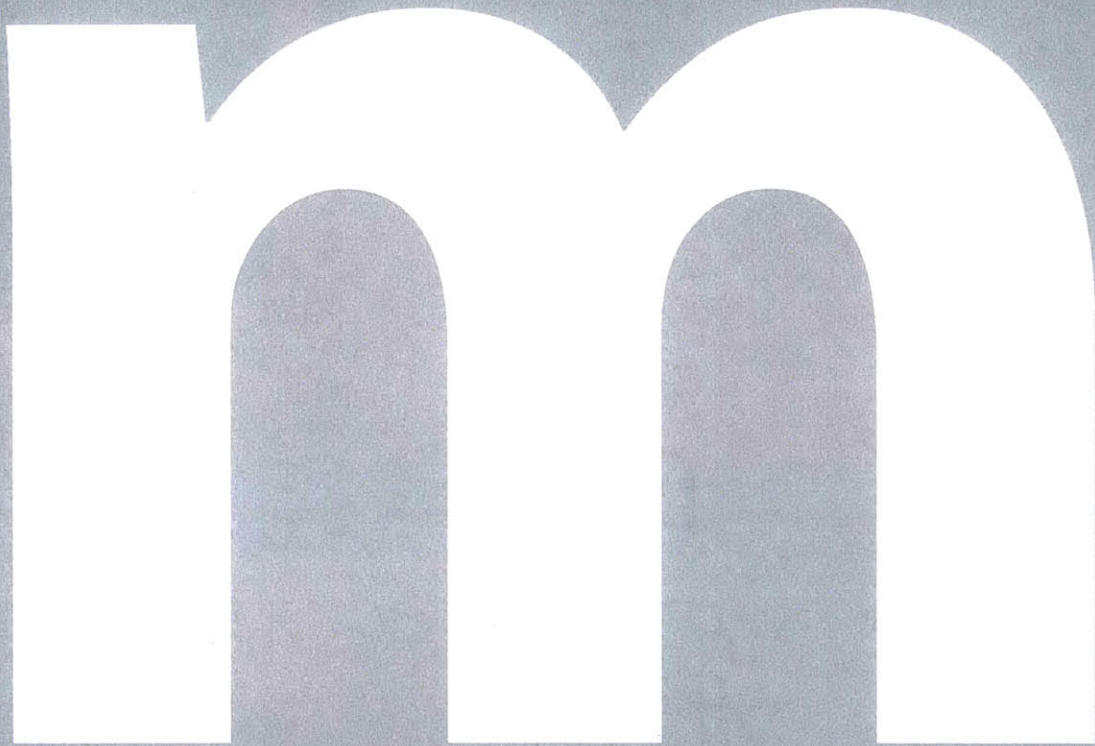

1s

SITE

• JAIPUR

INDIA

CLIMATE

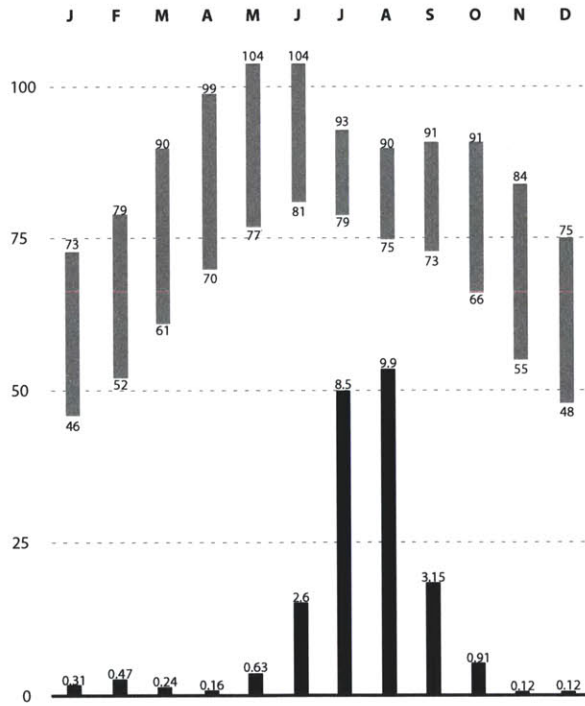

Above: Average max. and min. temperature / °F

Below: Rainfall / mm

Source: BBC Weather



MONSOON

RE-EXPERIENCING WIND

MONSOON is the third proposed apparatus prototype. Its design intends to induce the comfort sensation through air movement - wind. In addition to temperature and humidity, air movement also plays a critical role to affect the human comfort perception. According to the thermodynamic knowledge, both convection and evaporation processes and their respective processes rate are influenced by the degree of air movement. Thus, the MONSOON is design based on the idea of air movement to induce unique experience..

Site and Climate

Jaipur, a city at the northwestern India, is chosen to be the experiment site for MONSOON. According to the Köppen Climate Classification, the climate at Jaipur is hot semi-arid.⁸ During the monsoon period in summer time, the average temperature will rise to over hundred degree Ferinheight and the condition will become relatively humid.

⁸ Jaipur, Wikipedia. <http://en.wikipedia.org/wiki/Jaipur> Retrieved 01.23.2013

ACTIVITIES LEVEL

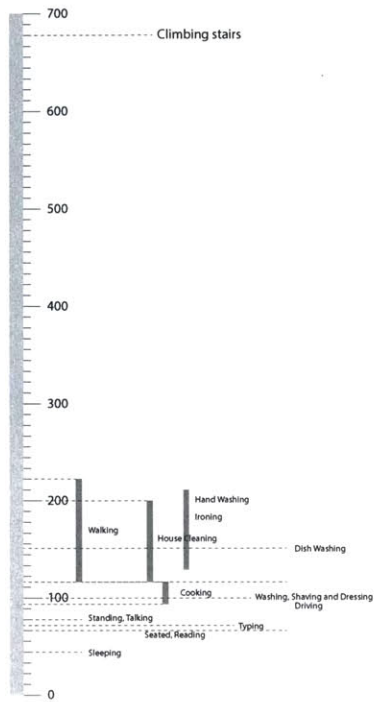

CLOTHING

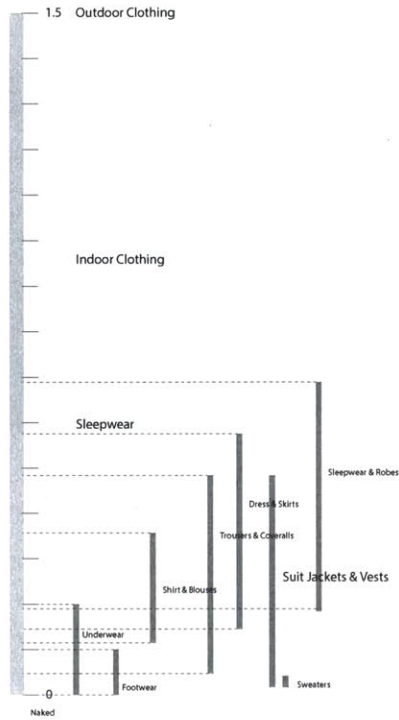

BEAUFORT WIND SCALE

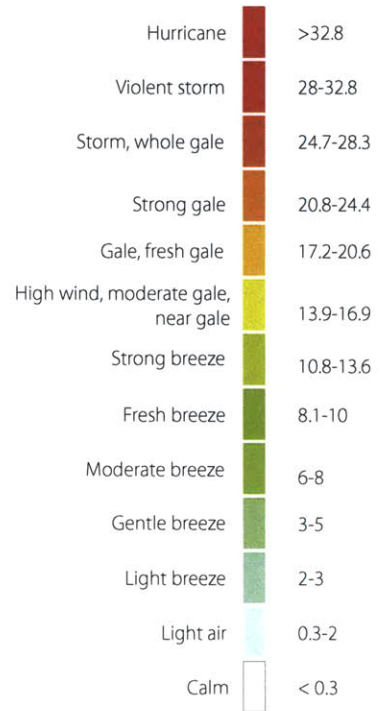

RUNNING TRACK

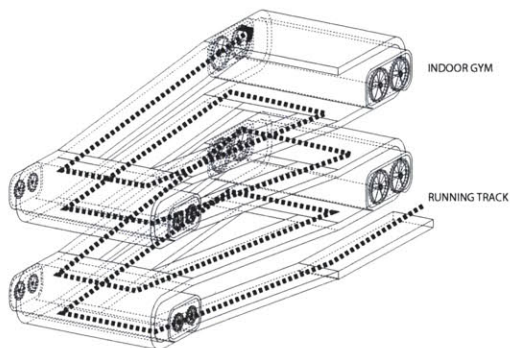

WIND SPEED

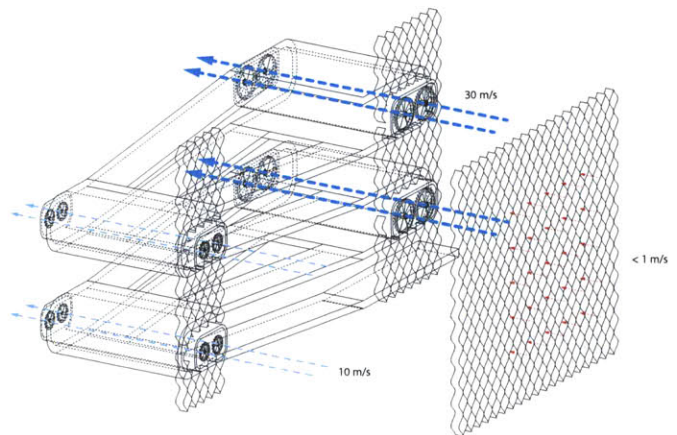

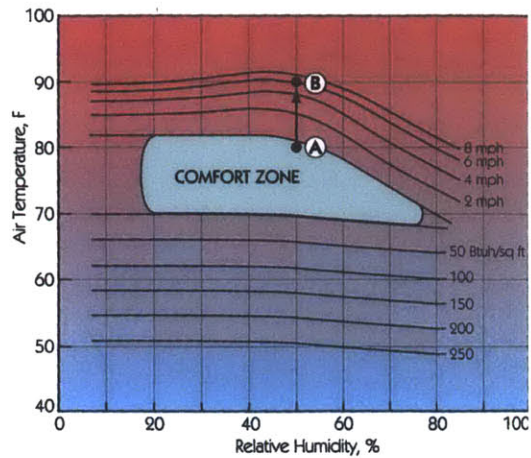

APPARATUS PERFORMANCE

The comfort experience induced by MONSOON is totally different from the previous apparatus prototypes. In MONSOON, human body becomes the active agent for obtaining comfort experience by physical exercise. The program of MONSOON is an urban fitness center with a spiral track consisting of multiple ramps. The programmatic intention is to offer people with comfort experience at different activity levels. A person who walk up the track will experience differently compared to a person who jogs or runs. When that person walk down the track the experience will be totally different again. Meanwhile the proliferated facade encourages good natural ventilation to provide steady air movement for minimum cooling. Apart from the spiral, there are four contained wind chambers with active mechanics ventilation system for more intensive exercises. As result, the comfort experience obtained in MONSOON is uniquely correlating to the respective body activities levels.

.....
SECTION

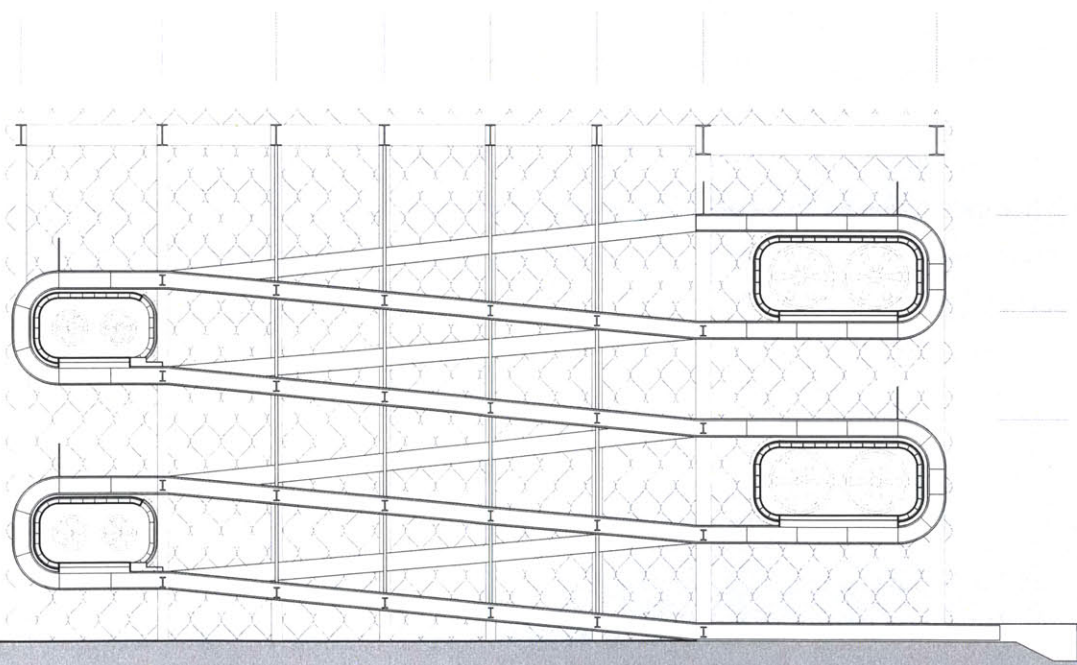

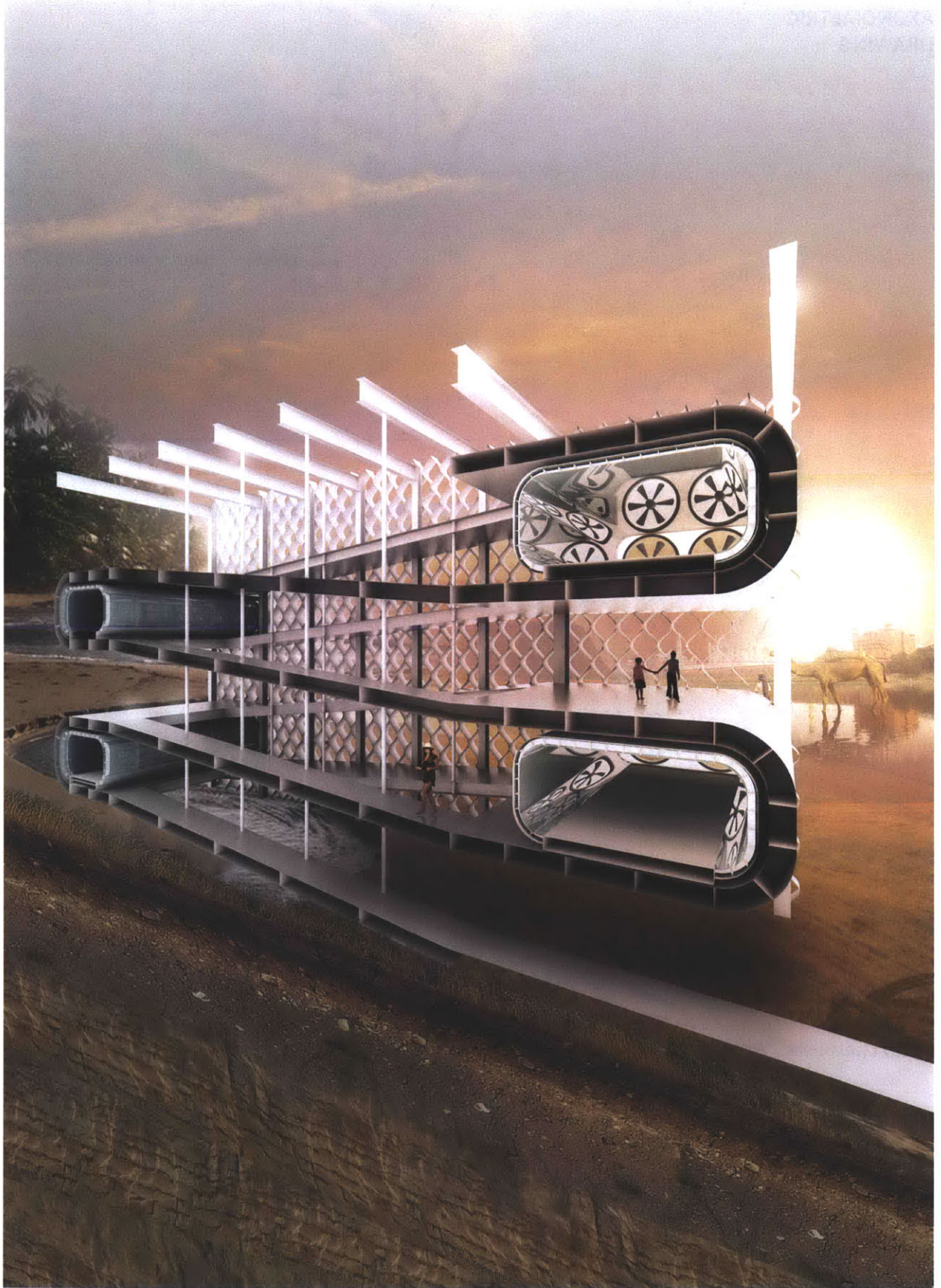

.....
**AXONOMETRIC
DRAWING**

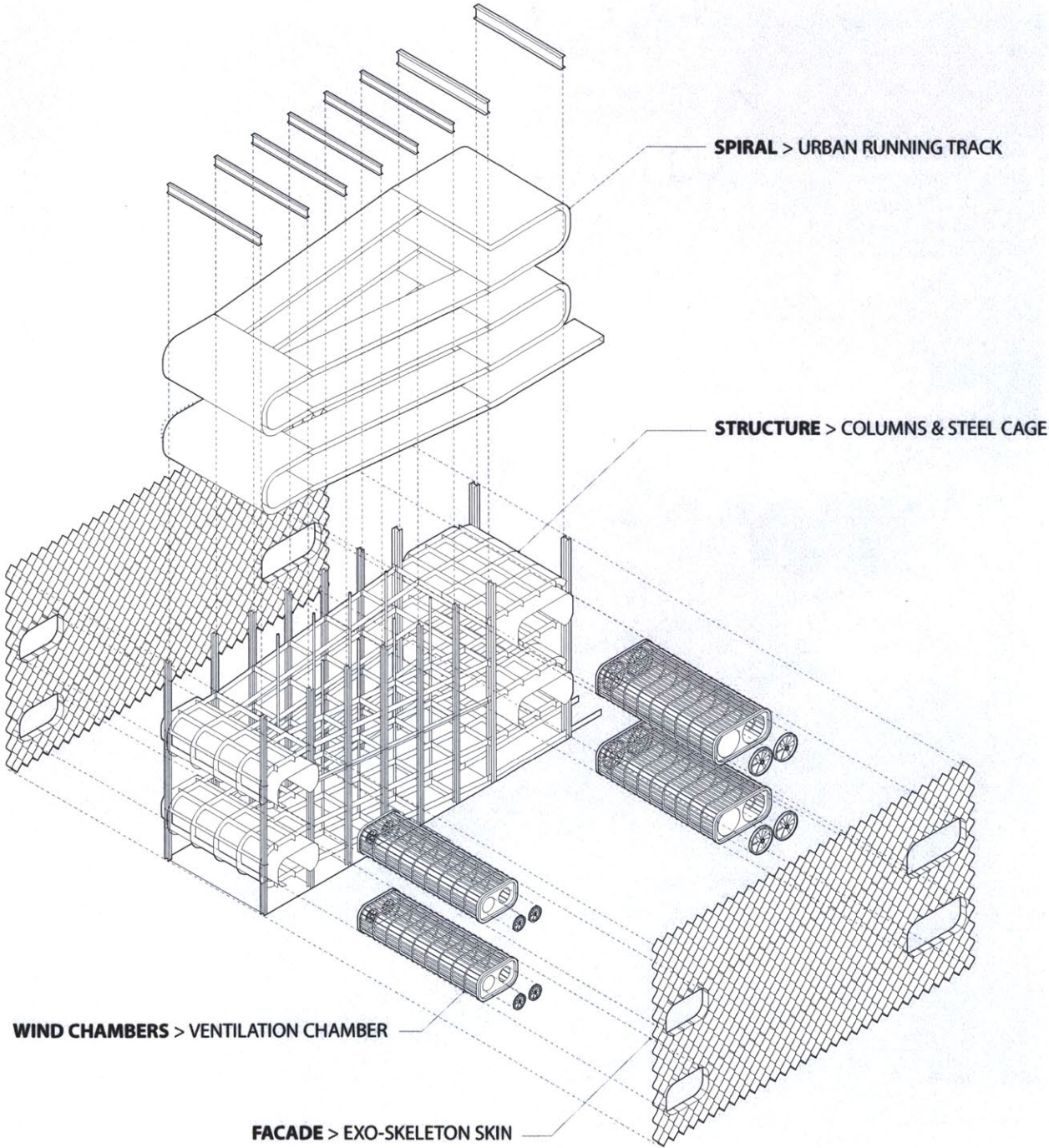

Components

The basic components of Monsoon consists a facade system, a spiral ramp system, four contained wind chambers and a structural frame system.

Facade

As mentioned above, the proliferated facades on MONSOON's long elevations ensure steady natural cross ventilation. At the same time, the highly permeable facades also create shading for the building to prevent over heating during sunny day.

Spiral

The spiral system provides an active exercise surface for experiencing difference body's activity levels. Contrasting to flat surface walking, navigating on the spiral required high amount of body exercise and energy input. As a result, it alerts the body metabolism rate and affects the thermal equilibrium. Thus, the thermal comfort experience is not perceived passively at a constant condition.

Wind Chambers

The contained wind chambers are dedicated for more intensive physical exercises of higher activity levels. Therefore, each chamber is equipped with mechanical ventilation for high thermal comfort requirement.





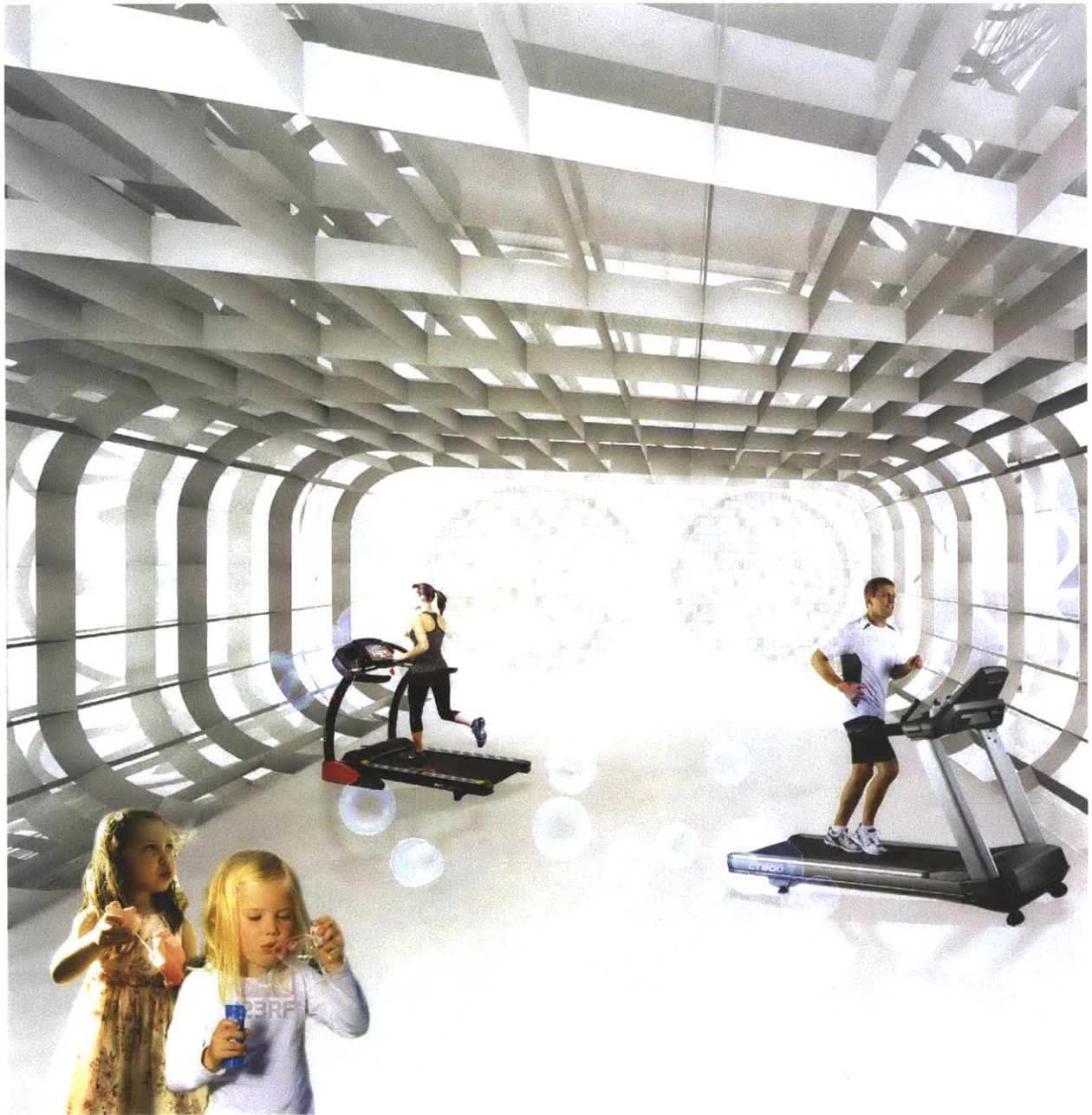

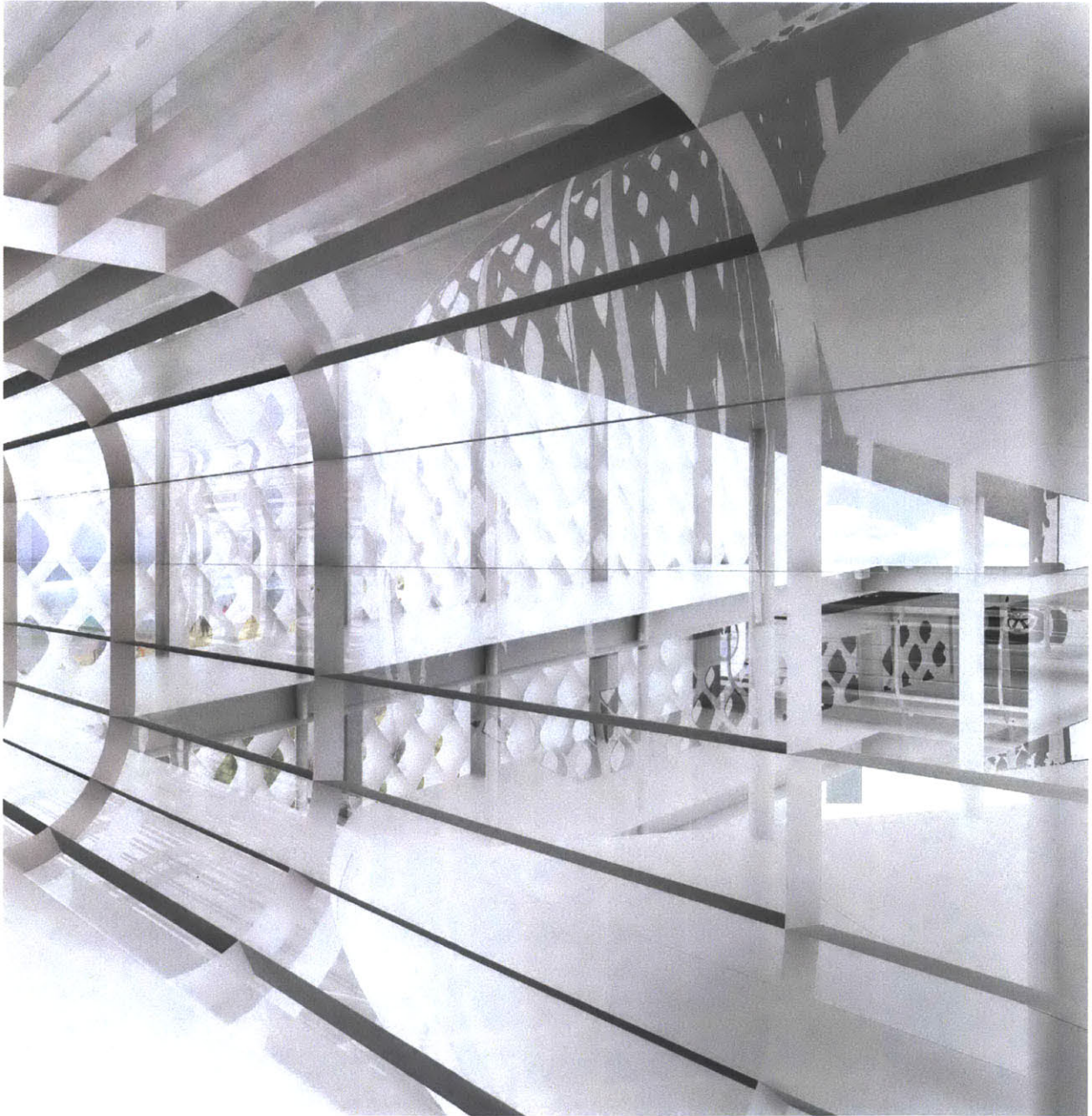

MODEL ARCHIVE



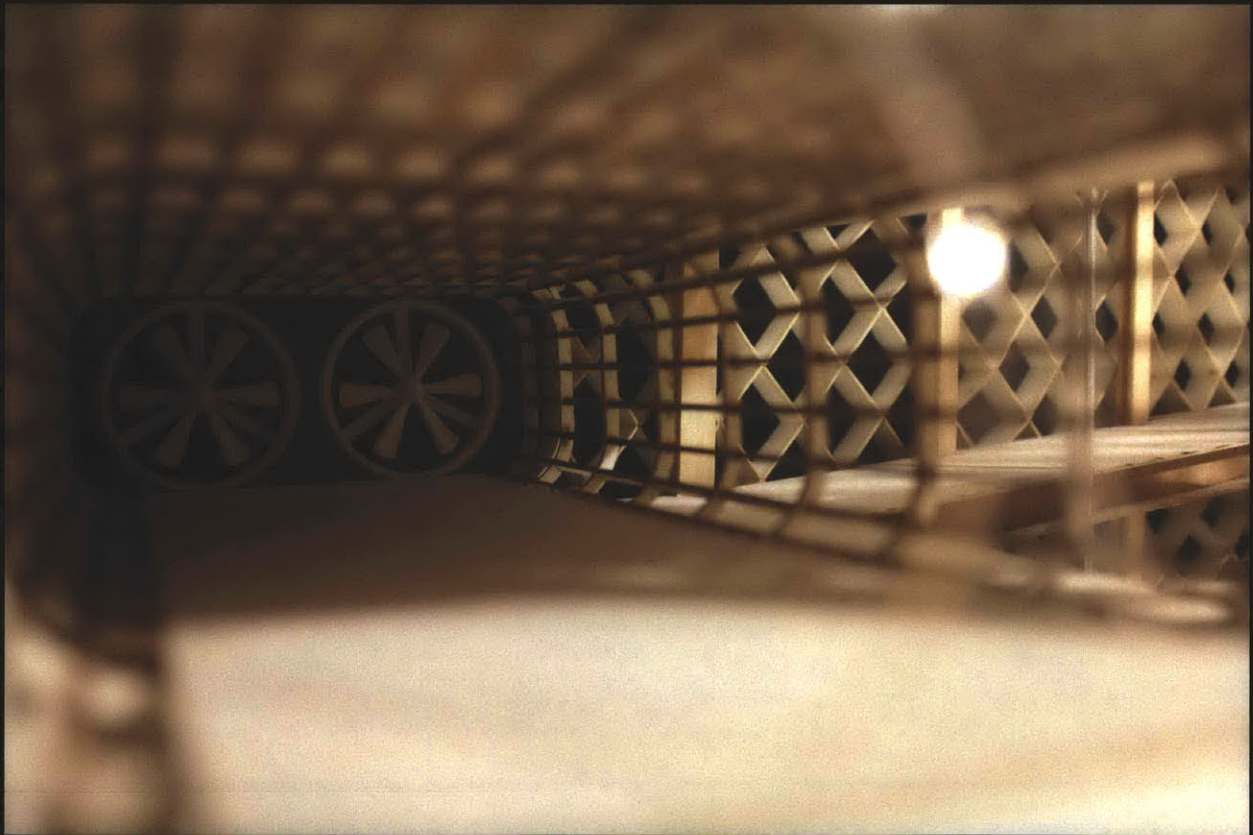

MODEL ARCHIVE





APPENDIX

THESIS DEFENCE

PUBLIC PRESENTATION | DEC.20.2012

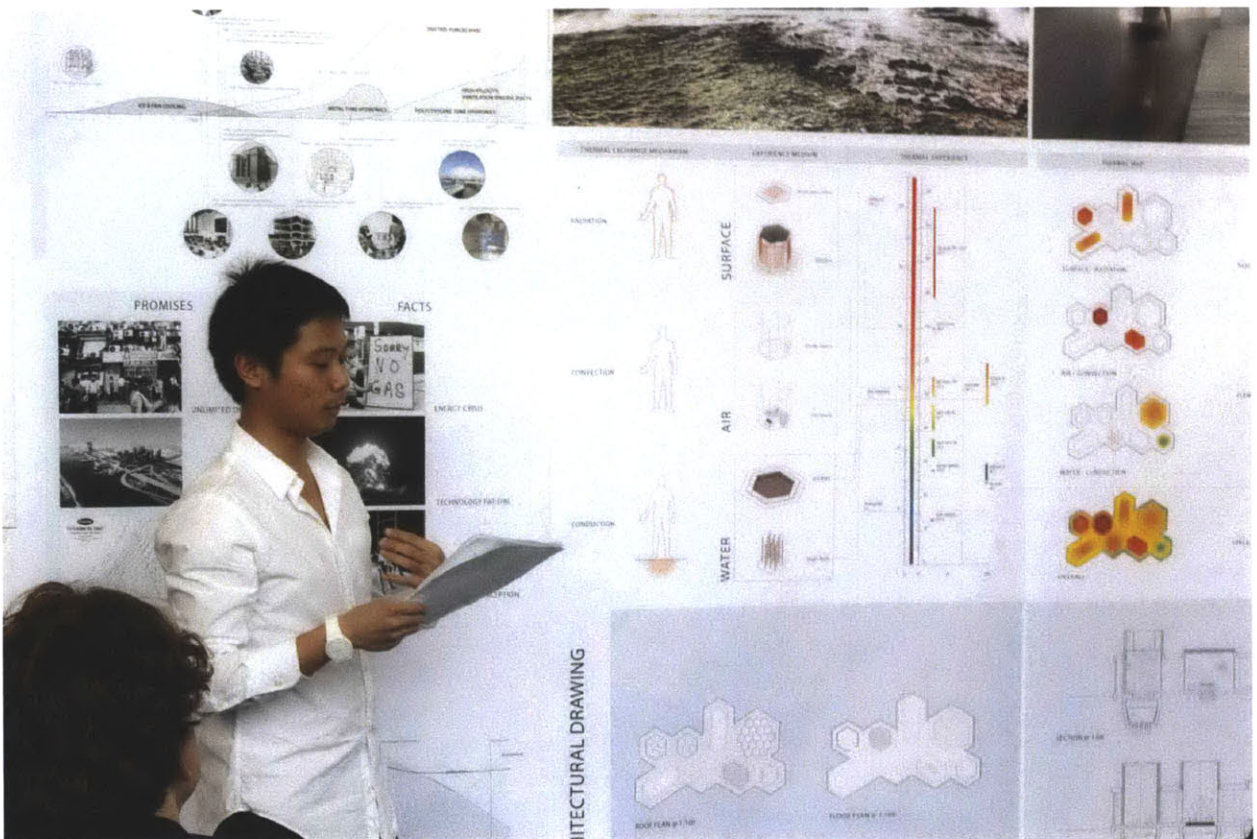



THESIS DEFENCE

PANELS

ATMOSPHERIC APPARATUS

INTRODUCTION OF A NEW MODERNITY FOR COMFORT

March Thesis Design Presentation: Hung Fai Tang | Advisor: Hader Tehrani | Readers: Christoph Reinhardt, Joel Lamore

MODERNITIES OF COMFORT

PROMISES

- UNLIMITED DEMAND
- CAPABLE TECHNOLOGY
- PERFECT STANDARD

FACTS

- ENERGY CRISIS
- TECHNOLOGY FAILURE
- SUBJECTIVE PERCEPTION

THESIS

DESIGN ARCHITECTURE OF ATMOSPHERIC CONDITION

DESIGN ARCHITECTURE AS APPARATUS

DESIGN ARCHITECTURE FOR EXPERIENCE

THERMAE
RE-EXPERIENCING HEAT

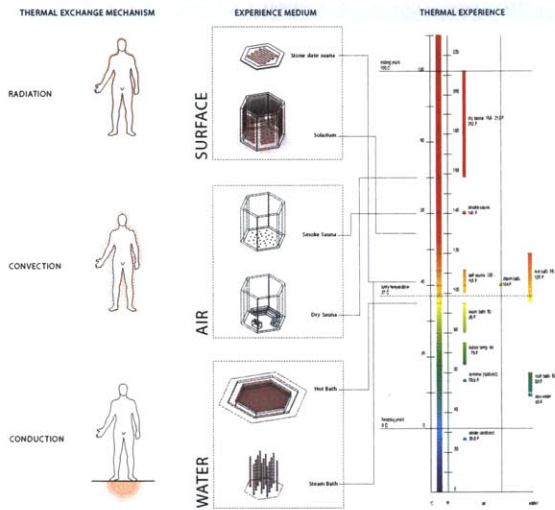
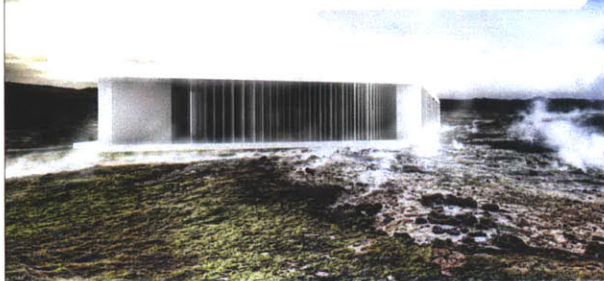

ARCHITECTURAL DRAWING

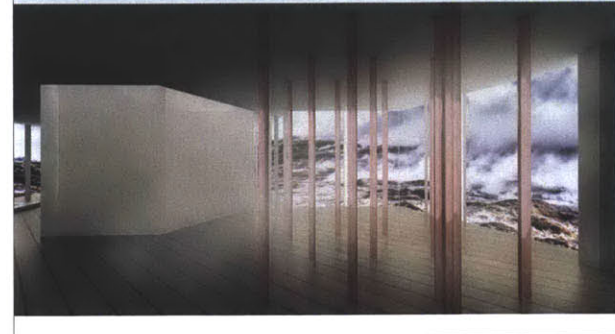
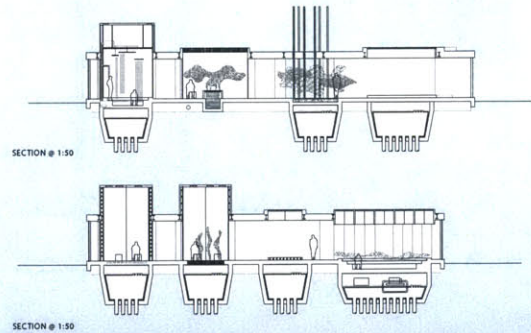
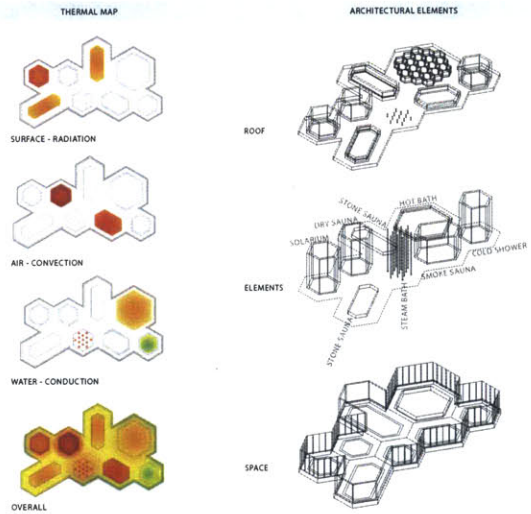
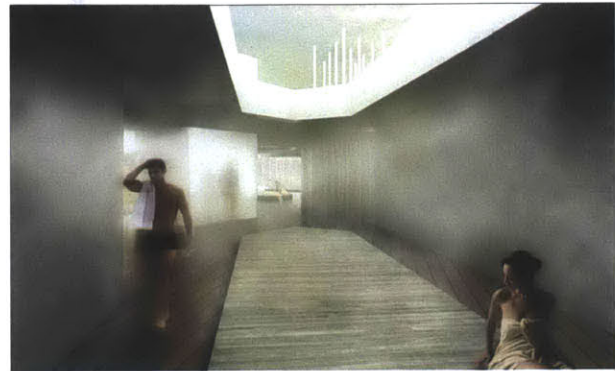
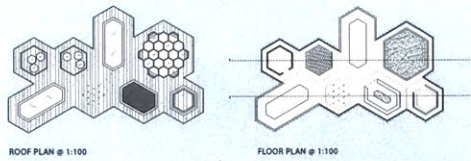

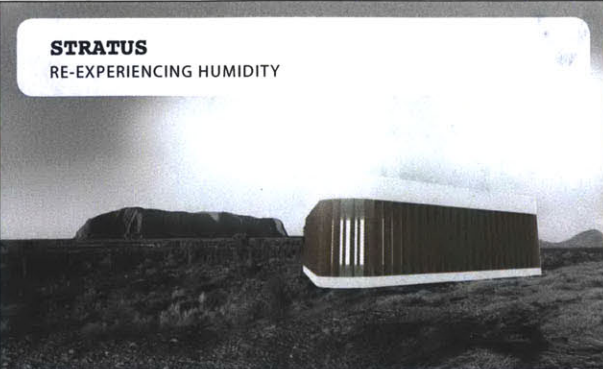

STRATUS
RE-EXPERIENCING HUMIDITY

HUMIDIFIER APPARATUS

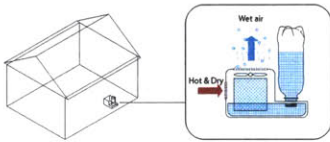

EVAPORATIVE COOLING EFFECT

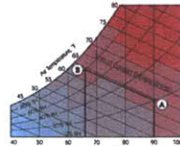

DAYTIME APPARATUS MECHANISM

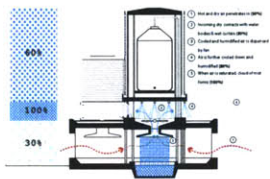

NIGHTTIME APPARATUS MECHANISM

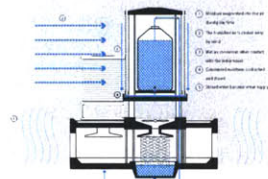

ROOF PLAN @ 1:100

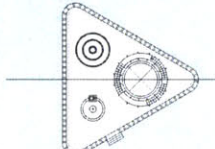

FLOOR PLAN @ 1:100



SECTION @ 1:50

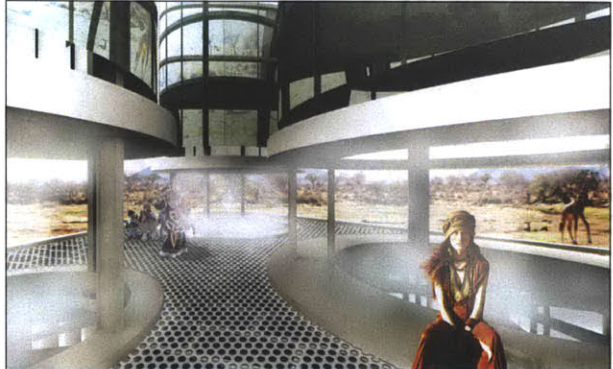
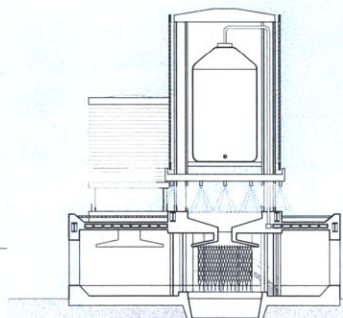

SYSTEMS

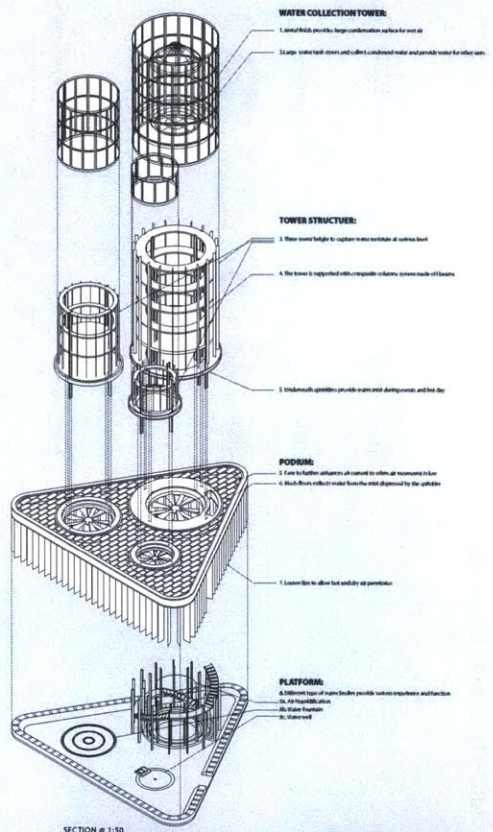

MONSOON
RE-EXPERIENCING WIND

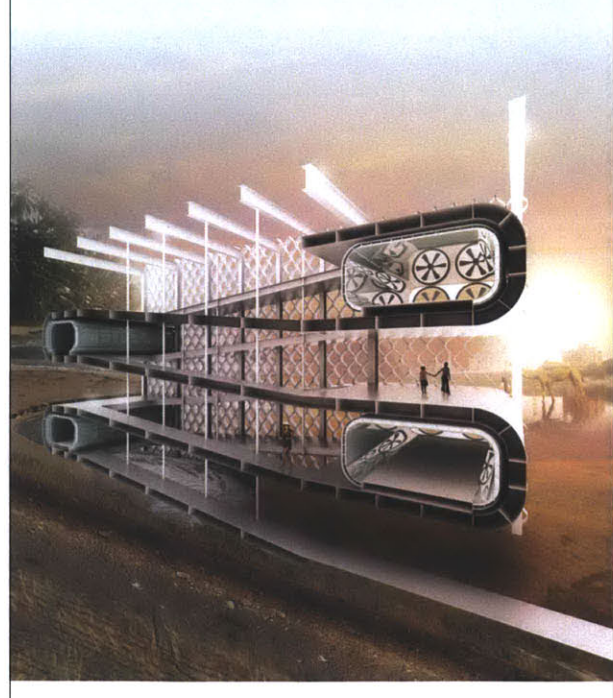
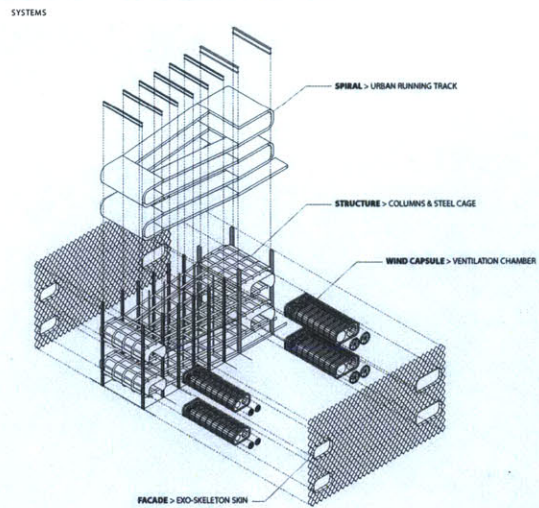
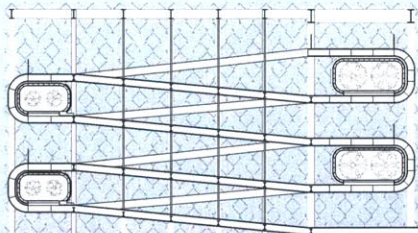
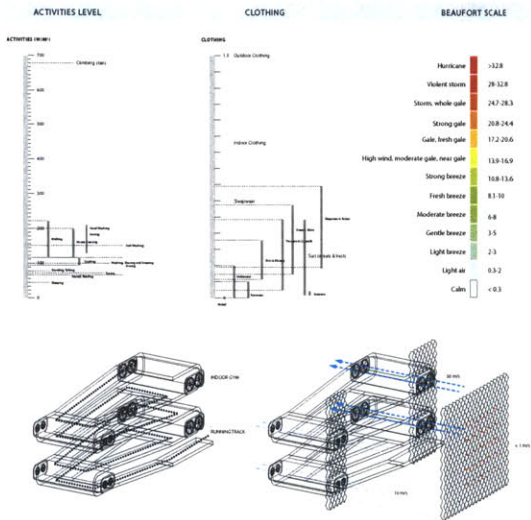

BIBLIOGRAPHY

BOOKS

1. Bradshaw, Vaughn. 1993. *Building control systems*. New York: Wiley.
2. Banham, Reyner. *The Architecture of the Well-Tempered Environment*. 1984 (1969). University of Chicago Press, Chicago. Capítulo "A Breath of Intelligence"
3. Clément, Gilles, Philippe Rahm, and Giovanna Borasi. 2006. Gilles Clément - Philippe Rahm: *environ(ne)ment : manières d'agir pour demain*. Milano: Skira
4. Fitch, James Marston, and William Bobenhausen. 1999. *American building: the environmental forces that shape it*. New York: Oxford University Press.
5. Mayer H., J., and Neeraj Bhatia. 2010. *-arium: weather + architecture*. Ostfildern: Hatje Cantz.
6. Lally, Sean. 2009. *Energies: new material boundaries*. Hoboken, N.J.: Wiley.
7. Lally, Sean, and Jessica Young. 2007. *Softspace: from a representation of form to a simulation of space*. London: Routledge
8. Le Corbusier. 1991. *Precisions on the present state of architecture and city planning: with an American prologue, a Brazilian corollary followed by the temperature of Paris and the atmosphere of Moscow*. Cambridge, Mass: MIT Press.
9. Moe, Kiel. 2010. *Thermally active surfaces in architecture*. New York: Princeton Architectural Press.
10. Nelson, George, and Henry Wright. 1945. *Tomorrow's house*. New York: Simon and Schuster.
11. Olgyay, Victor. *Design with climate*. (1963). Princeton University Press

