

DESIGN OF CENTRAL
IRRADIATION FACILITIES FOR
THE MITR-II RESEARCH REACTOR

by

PAUL CHRISTOPHER MEAGHER

B.S., Rensselaer Polytechnic Institute
1975

SUBMITTED IN PARTIAL FULFILLMENT
OF THE REQUIREMENTS FOR THE
DEGREE OF MASTER OF
SCIENCE

at the

MASSACHUSETTS INSTITUTE OF
TECHNOLOGY

September, 1976

(i.e. February, 1977)

Signature of Author.....
Department of Nuclear Engineering,
(September 30, 1976)

Certified by.....
Thesis Supervisor

Accepted by.....
Chairman, Departmental
Committee



DESIGN OF CENTRAL IRRADIATION
FACILITIES FOR THE MITR-II RESEARCH REACTOR

by

Paul Christopher Meagher

Submitted to the Department of Nuclear Engineering
on September 30, 1976 in partial fulfillment of the
requirements for the degree of Master of
SCIENCE

ABSTRACT

Design analysis studies have been made for various in-core irradiation facility designs which are presently used, or proposed for future use in the MITR-II. The information obtained includes reactivity effects, core flux and power distributions, and estimates of the safety limits and limiting conditions for operation. A finite-difference, diffusion theory computer code was employed in two and three dimensions, and with three and fifteen group energy schemes. The facilities investigated include the single-element molybdenum sample holder, a proposed double-element irradiation facility and a proposed central irradiation facility design encompassing most of the area of the three central core positions. In addition, a comparison of the effects of various absorber materials has been made for a core configuration which includes three solid dummies.

Flux levels in the molybdenum holder facility and in the beam ports were calculated for both three and five dummy cores. Flooding the sample tube in these cases was found to increase the safety and operating limits, but not to unacceptable levels for an 8 inch blade height. For the five dummy case, the operating limit in the C-ring was predicted to reach its maximum allowed value at a blade bank height of 13.6 inches. The reactivity effect of flooding was calculated to be $0.19\% \Delta K_{eff}$ for the five dummy case, in direct agreement with the measured value. Flooding the large sample channel in the double element facility was found to increase the reactivity by $1.56\% \Delta K_{eff}$, and also to cause an unacceptable powerpeaking.

The proposed central irradiation facility is a thermal flux-trap which could produce thermal flux values of up to 2.0×10^{14} n/cm²sec. Computer estimates show that flooding this facility's central sample tube would increase this value to 2.5×10^{14} n/cm²sec, without resulting in an unacceptable power peak.

Thesis Advisor: D. D. Lanning
Title: Professor of Nuclear Engineering

	<u>Page</u>
ABSTRACT	2
LIST OF FIGURES	5
LIST OF TABLES	7
ACKNOWLEDGEMENTS	8
CHAPTER 1 INTRODUCTION	9
CHAPTER 2 CALCULATIONAL METHODS	16
2.1 The Computer Code, CITATION	16
2.2 Cross Section Data	17
2.2.1 Fuel Cross Sections	18
2.2.2 Control Blade Cross Sections	20
2.2.3 Steel and Molybdenum Cross Sections	29
CHAPTER 3 SAFETY LIMIT AND LIMITING CONDITION FOR OPERATION	32
3.1 Safety Limit	32
3.2 Limiting Condition for Operation	34
3.3 Evaluation of the Safety and Operating Limits	35
CHAPTER 4 SINGLE ELEMENT IRRADIATION FACILITIES	44
4.1 Original In-Core Sample Assembly	44
4.2 Molybdenum Sample Holder	46
CHAPTER 5 DOUBLE ELEMENT IRRADIATION FACILITY	54
5.1 Fifteen Group CITATION Study	56
5.2 Three Group CITATION Study	61

CHAPTER 6	CENTRAL IRRADIATION FACILITY STUDIES	68
6.1	Effect of Various Materials in the Central Facility	69
6.2	Proposed Central Irradiation Facility Design	77
CHAPTER 7	CONCLUSIONS AND RECOMMENDATIONS FOR FURTHER WORK	87
REFERENCES		94
APPENDIX A	CONTROL BLADE HOMOGENIZATION AND MESH CORRECTION	96
APPENDIX B	THREE DUMMY CORE CALCULATIONS	102
APPENDIX C	THE COMPUTER CODE, LIMITS	114
APPENDIX D	SAMPLE CITATION OUTPUT	121

	<u>Page</u>
LIST OF FIGURES	
1-1 Cross Section of the MITR-II Facility	10
1-2 Vertical Cross-section of the MITR-II Core	11
1-3 Horizontal Cross-section of the MITR-II Core	13
1-4 MITR-II Fuel Element	14
2-1 Horizontal Section of the Fixed Absorber Spider with Hafnium Inserts in Place	24
4-1 Original In-core Sample Assembly Design	45
4-2 Molybdenum Sample Holder Design	47
4-3 Horizontal Section Showing Core Model for Molybdenum Sample Holder	49
5-1 Horizontal Section of A-ring Core Positions with Double Element Facility in Place	55
5-2 Two-dimensional Core Model used for Fifteen Group Steel Sample Calculations	57
5-3 Fast Flux (Radially Averaged Across Steel Sample) as a Function of Axial Position	60
5-4 Horizontal Section Showing Core Model for Double Element Irradiation Facility	62
5-5 Fast and Thermal Fluxes along Centerline of Steel Sample	65
5-6 Fast and Thermal Fluxes across Steel Sample at a Point Halfway Up Sample	66
6-1 Thermal Flux Along Centerline of Central Irradiation Facility Filled with Various Materials	74
6-2 Epithermal Flux Along Centerline of Central Irradiation Facility Filled with Various Materials	75

6-3	Thermal Flux Plotted Radially from Centerline of Central Facility for Various Materials	76
6-4	Vertical Cross Section of Proposed Central Irradiation Facility	78
6-5	Horizontal Cross Section of Proposed Central Facility with Rectangular Molybdenum Sample Regions	79
6-6	Horizontal Cross Section of Proposed Central Facility with Cylindrical Molybdenum Sample Regions	86
6-7	Two-dimensional Core Model used for Proposed Central Facility Calculations	82
6-8	Vertical Section of Proposed Central Facility Showing Lines of Constant Thermal Flux	85
B-1	Core Power Peaking as a Function of Axial Position for Element A-2 (plate 1)	107
B-2	Core Power Peaking as a Function of Axial Position for Element B-15	108
B-3	Core Power Peaking as a Function of Axial Position for Element C-8 (plate 1)	109
B-4	Thermal Flux as a Function of Axial Position for Element A-2	110
B-5	Thermal Flux as a Function of Axial Position for Element C-8	111
B-6	Thermal Flux as a Function of Axial Position for Corner Hole #2.	112

LIST OF TABLES

	<u>Page</u>
2-1 Energy Structure of the Three and Fifteen Group Cross Section Sets	19
2-2 Boron-Stainless-Steel Control Blade Composition	27
2-3 Composition of A533 (Type B) Steel Sample	31
3-1 Factors used in Safety and Operating Limit Evaluation	36
3-2 Values of Plenum Flow Disparity (d_{FP}) for Three and Five Dummy Core Configurations	37
3-3 Comparison of Experimentally Determined and Computer-Generated Values of F_R , F_A , and Z for a THREE-DUMMY Core Configuration	39
3-4 Comparison of Experimentally Determined and Computer-Generated (with old Cd Cross Section Data) Values of F_R , F_A , and Z for a FIVE-DUMMY Core Configuration	41
4-1 Results of Limit Calculations for the Molybdenum Sample Holder	51
4-2 Results of CITATION Thermal Flux Calculations for the Molybdenum Sample Holder	53
5-1 Zone Compositions for 15 group Steel Sample Calculation	58
5-2 Results of Three Group Double Element Facility Calculation	64
6-1 Results of Two-dimensional CITATION Study of Various Materials in the Central Facility	71
6-2 Results of CITATION Flux Calculations for Various Materials in the Central Facility	72
6-3 Zone Compositions for 3 group Flux-trap Facility Calculations	83
7-1 Results of CITATION Flux Calculations for Various Core Configurations	90
B-1 Results of 3 Dummy ⁺ Core Study	103
B-2 Beam Port Thermal Flux Values Generated by CITATION for the Three Dummy Core Study	105

ACKNOWLEDGMENTS

The author wishes to thank Dr. D. D. Lanning for his guidance and advice, without which this study could not have been accomplished. The help of Dr. A. F. Henry, especially in the development of neutron cross section data, has also been greatly appreciated.

Mr. R. Chin and Dr. G. Allen have taken much of their time to explain various aspects of the MITR-II, and the techniques used to study this facility. Their advice and encouragement have been invaluable. Thanks also go to Rachel Morton for her assistance with computer codes, and to Cindi Mitaras for her part as typist.

The computations for this report have been done at the MIT Information Processing Center.

CHAPTER I

INTRODUCTION

The nuclear reactor facility at the Massachusetts Institute of Technology has been a valuable asset to student instruction and research for many years. Operation began in 1958 with the criticality of the MITR-I core. This design produced a maximum thermal power of 5 MW with a fully enriched uranium-aluminum alloy fuel, and a heavy water coolant and moderator. The MITR-I performed well during its planned lifetime and was shutdown in 1974 for a complete core revision.

The new design, called the MITR-II, was developed to provide increased reliability and higher neutron flux levels at the beam ports. Like the MITR-I, the rated thermal power is 5 MW, but the new core is more compact, with a higher power density. A cross section of the facility is shown in Figure 1-1. Light water flows down around the outer edges of the core, and then up through the fuel elements to a large upper plenum. The region surrounding the core tank contains a heavy water reflector which can be dumped as a safety shutdown mechanism. Beam ports extend through the reactor's concrete shielding into the reflector region below the core. These ports allow for sample irradiation in this high flux region or can provide a neutron beam path to instruments located outside the shielding.

Figure 1-2 is a vertical cross section of the MITR-II core. As shown, fixed neutron absorbers may be positioned in the upper fueled region. These serve to push the maximum reactor power toward

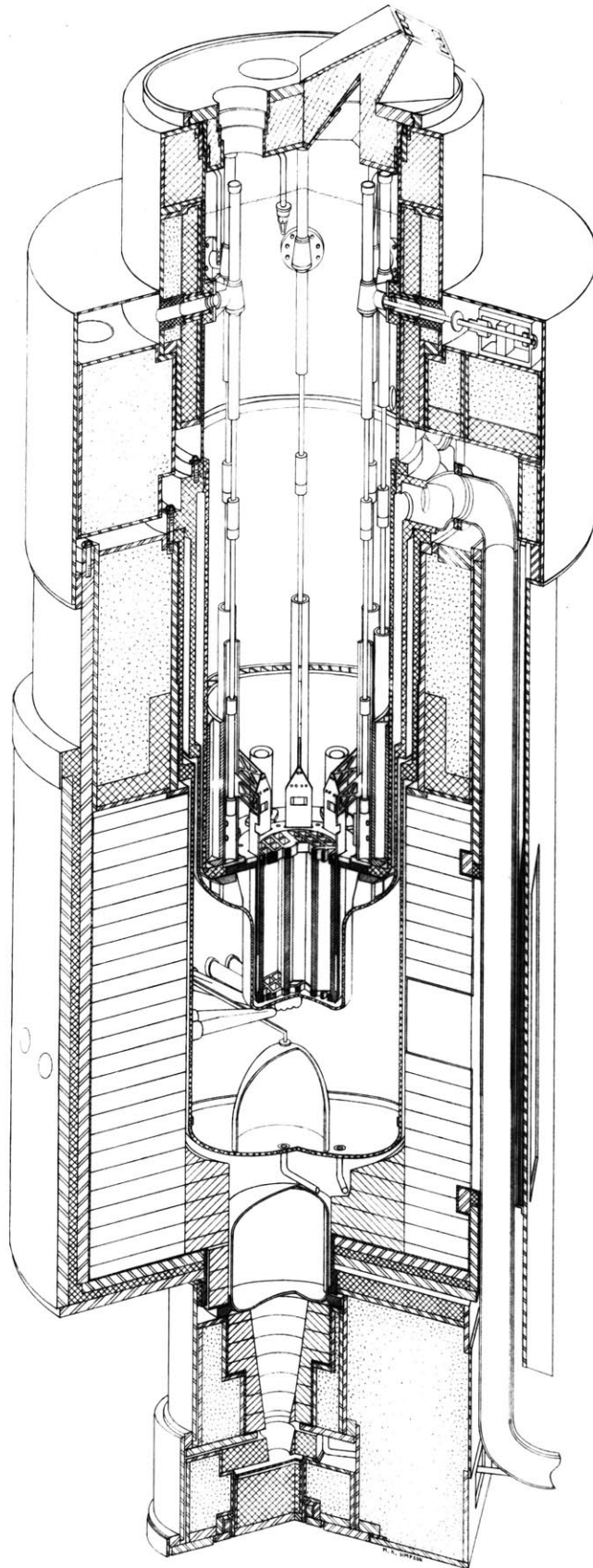
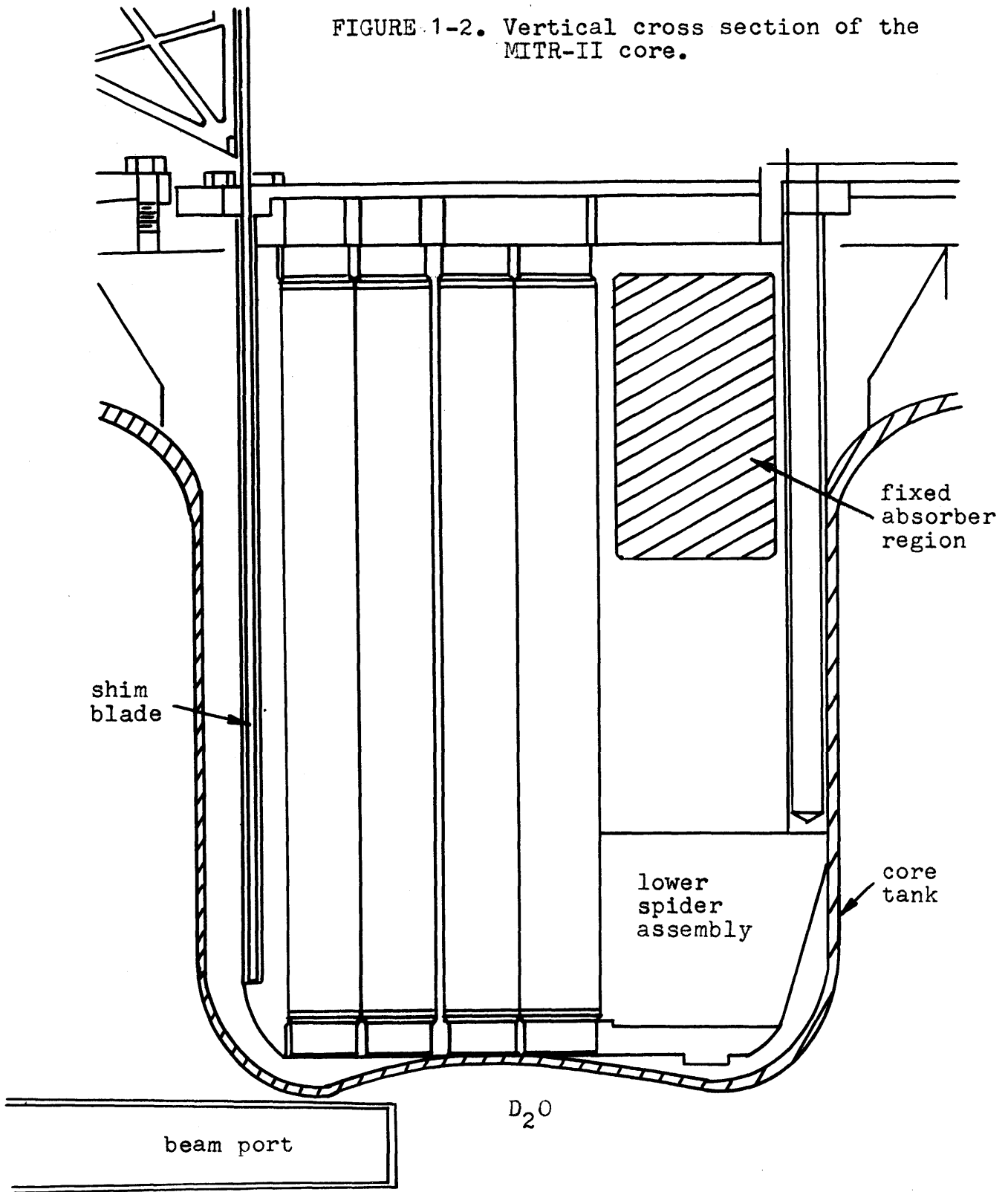

FIGURE 1-1. Cross section of the MITR-II facility.

FIGURE 1-2. Vertical cross section of the MITR-II core.



the bottom of the core, enhancing the thermal flux obtained from the beam ports. In addition, burnup in the upper half of the fuel is reduced. By inverting and reusing once-burned fuel elements, a longer fuel life can be obtained.

Normal reactivity control is accomplished by the motion of six shim blades and one smaller regulating rod. These absorbers essentially form a ring which shields the core from the surrounding reflector. This orientation can be seen in the horizontal core section of Figure 1-3.

The core itself is hexagonal in cross section, with a 15.0 inch span across the flats. It is composed of up to twenty-seven fuel elements which form three concentric rings. Three positions form the innermost, or A-ring, while the B and C-rings contain nine and fifteen positions, respectively. A single fuel element is pictured in Figure 1-4. Each contains fifteen finned fuel plates held in place by the rhomboid body of the element. The plates consist of an alloy of thirty-five weight percent uranium (93% enriched) in aluminum, surrounded by an aluminum cladding.

The MITR-II can be operated with several non-fueled core positions. This allows space for the placement of various experimental facilities into the core in order to hold materials such as irradiation samples or a neutron source. This research report deals with the evaluation of the experimental facilities which have been used in the MITR-II core. In addition, an investigation is made into the feasibility of several other facilities which have been proposed for future use.

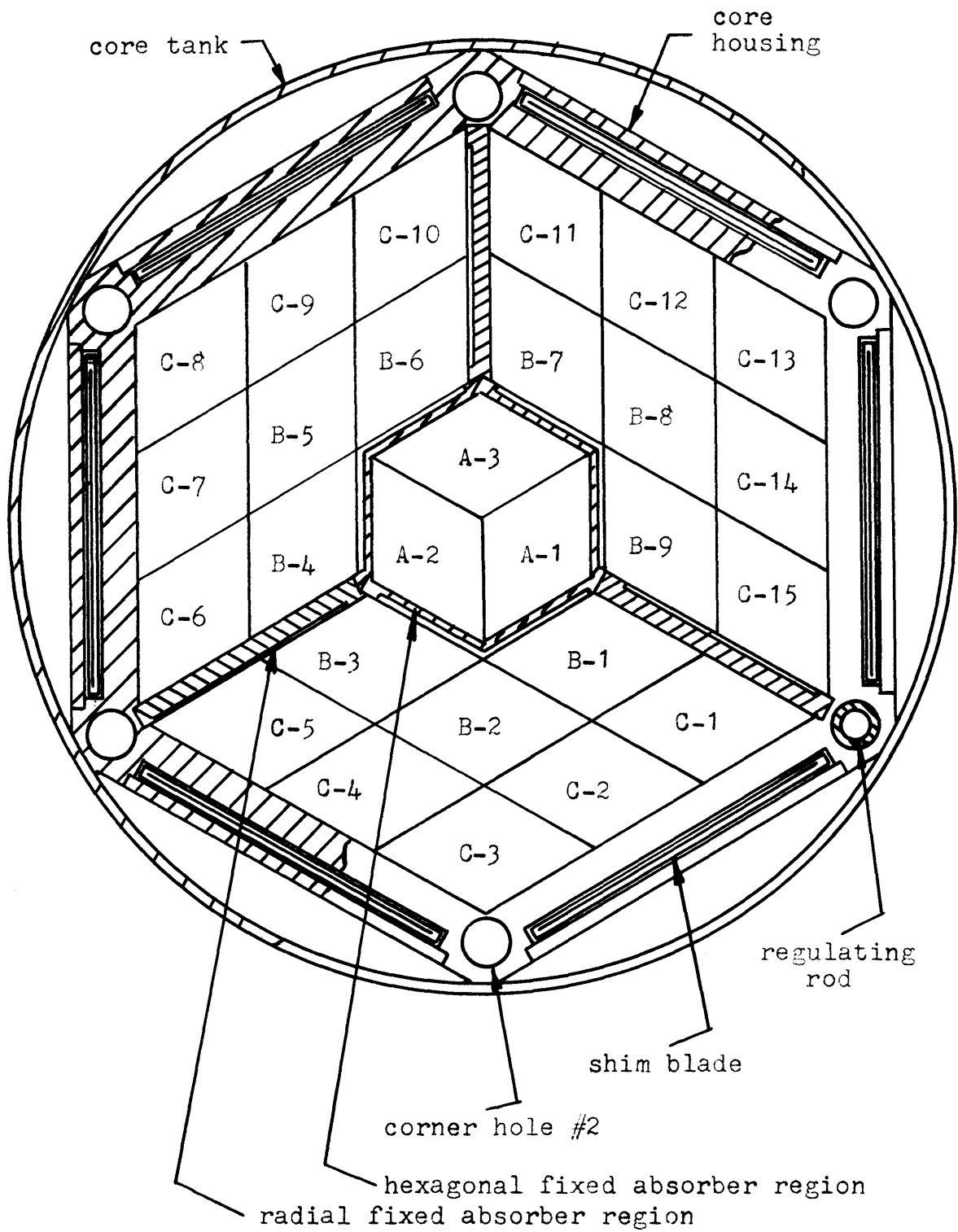

FIGURE 1-3. Horizontal cross section of the MITR-II core.

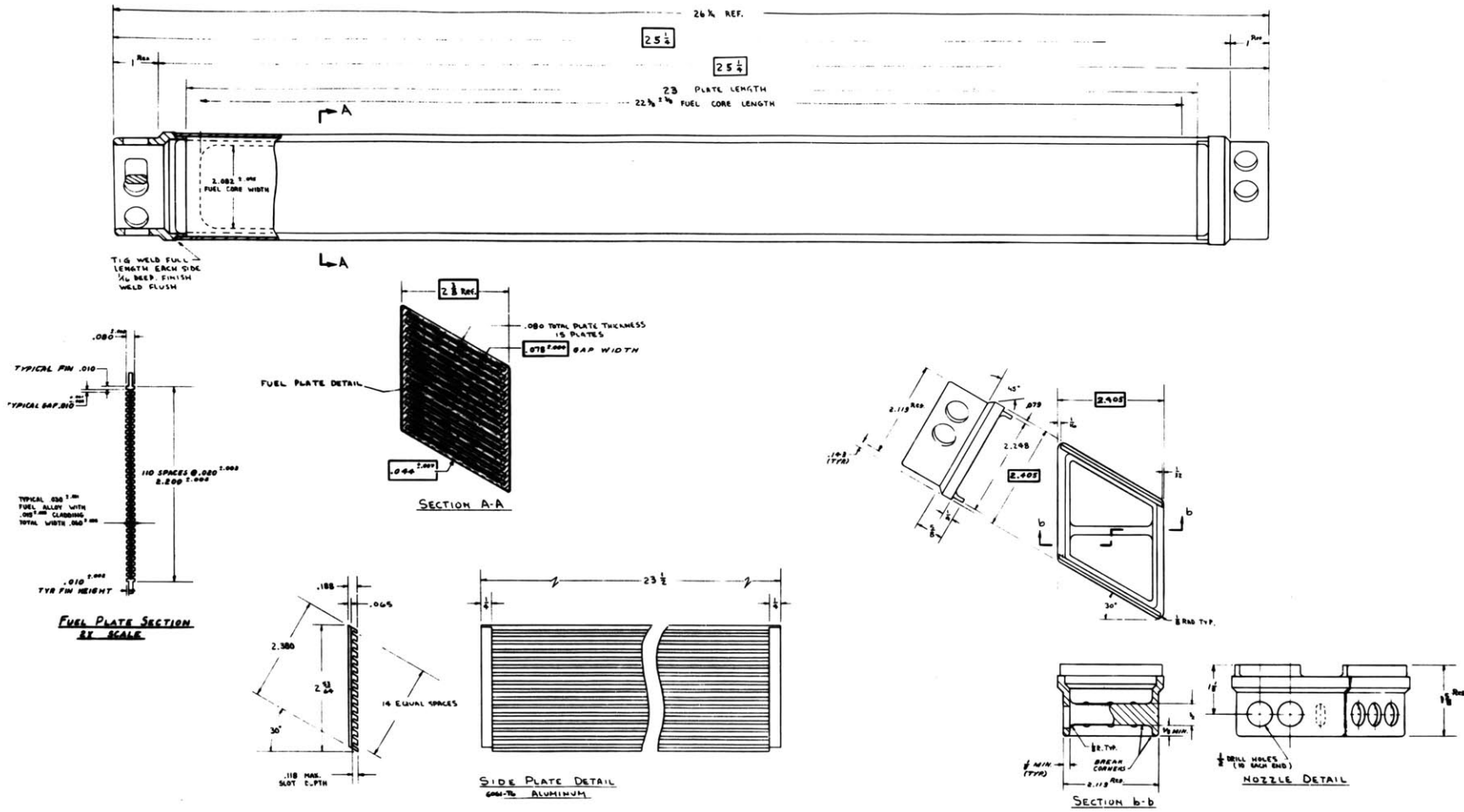

FIGURE 1-4. MITR-II fuel element.

Chapter 2 deals with some of the considerations involved in analyzing in-core facilities and includes the calculational methods required for the neutronic portion of such an analysis. An explanation and description of the safety limit and limiting condition for operation are contained in Chapter 3. These two technical specification limits place restrictions upon reactor operation in order to avoid power peaking which could produce an adverse effect on fuel cladding integrity.

Chapters 4, 5 and 6 explain the various facilities studied, the procedures employed in their evaluation, and the results obtained. Chapter 7 summarizes and draws conclusion about the results, and then goes on to suggest paths which future work might take.

CHAPTER 2

COMPUTATIONAL METHODS

The evaluation and design of an incore assembly for a reactor such as the MITR-II must include consideration of various neutronic effects. For example, the introduction of too great a volume of water into the core can produce an unacceptable power peaking in adjacent fuel elements. The effect of an assembly on the thermal neutron flux obtained from the beam ports is also an important factor. In addition, reactivity effects must be investigated in this type of analysis, due to reactor control and safety considerations. Each of these constraints must be balanced against the desire for attaining the maximum possible neutron flux with the most useful energy spectrum.

In order to perform these evaluations of limiting conditions and optimum designs, information such as the core power and flux distributions, and K_{eff} values for various core configurations, must be known. The tool which was most often used in this research study to find the required information was the computer code CITATION (Ref. 1).

2.1 THE COMPUTER CODE, CITATION

This code is a finite-difference, diffusion theory code which was developed at the Oak Ridge National Laboratory. Beyond those capabilities previously mentioned, CITATION can

be used to determine the solution of perturbation and depletion problems, calculate the adjoint flux, and generate flux-weighted macroscopic cross sections.

CITATION was run in both the two-dimensional (R,Z) and three-dimensional (R, θ ,Z) modes, depending upon the core configurations being modelled and the degree of accuracy required. This code has the ability, however, of handling various other geometries.

The neutron energy structure employed for the majority of the cases was a three group scheme. Fifteen group calculations were also performed in order to flux-weight fifteen group cross section sets to a three group structure. The result of such a "collapse" run is a set of three group macroscopic cross sections for each different mixture of materials. These three and fifteen group cross section sets are further described in the next segment of this chapter.

The core models and finite-difference mesh spacings used to mockup various core configurations are detailed throughout later chapters.

2.2 CROSS SECTION DATA

The three group cross section set used for MITR-II calculations was originally developed by Kadak (Reference 2) and Addae (Reference 3). This set was collapsed from the previously mentioned fifteen group set which had been modelled after that of Hansen and Roach (Reference 4). Collapsing was accomplished by use of the finite

difference, diffusion theory code, EXTERMINATOR-II (Reference 5). The energy structure of the three and fifteen group sets is listed in Table 2-1.

2.2.1 Fuel Cross Section

In the energy range above 1 ev, the neutron diffusion length is long enough such that the fueled core regions can be considered as homogeneous. In the thermal range, however, the diffusion length is on the same order as the fuel plate thickness. It was therefore necessary to consider the heterogeneity of the fuel elements in the development of the fuel's thermal cross sections. This was accomplished by iteratively using the transport theory code, THERMOS (Reference 6). The first step homogenized a single fuel cell (fuel plate and surrounding moderator), while the second went on to homogenize a series of cells into a full element.

Fuel placed in different regions of the core will experience different neutron energy spectrums. This is largely dependent upon nearness to the reactor's reflector. Additional THERMOS calculations were therefore performed by Kadak to obtain homogenized fuel cross sections averaged over the neutron spectrum radially and axially throughout the core. The resulting thermal cross sections then formed the lowest two groups of the modified Hansen and Roach set, which was subsequently collapsed to the final three group set.

TABLE 2-1

ENERGY STRUCTURE OF THE THREE AND FIFTEEN GROUP CROSS-SECTION SETS

Three Group Set:

Group	Energy Range (ev)
1	.00025 - .40
2	.40 - 3.00×10^3
3	3.00×10^3 - 10.00×10^6

Fifteen Group Set:

Group	Energy Range (ev)
1	3.00×10^6 - 10.00×10^6
2	1.40×10^6 - 3.00×10^6
3	$.90 \times 10^6$ - 1.40×10^6
4	$.40 \times 10^6$ - $.90 \times 10^6$
5	$.10 \times 10^6$ - $.40 \times 10^6$
6	17.00×10^3 - 100.00×10^3
7	3.00×10^3 - 17.00×10^3
8	$.55 \times 10^3$ - 3.00×10^3
9	100 - 550
10	30 - 100
11	10 - 30
12	3 - 10
13	1 - 3
14	.4 - 1
15	.00025 - .4

2.2.2 Control Blade Cross Sections

Great care must be taken to ensure the accurate representation of a strongly absorbing control material in a diffusion theory calculation. The diffusion theory approximation to the transport equation breaks down in the presence of such a material. Therefore, equivalent diffusion theory parameters must be found which approximate the actual absorption taking place in the control material. This can be done by the use of blackness theory, which is detailed in a paper by Henry (Reference 7).

Blackness theory can be readily applied to control blades which approximate an infinite slab, and in which scattering may be neglected. The theory first defines blackness coefficients in terms of the net current and fluxes at either side of the slab:

$$\alpha(E) = \frac{j^+ + j^-}{\phi^+ + \phi^-} \tag{2-1}$$

$$\beta(E) = \frac{j^+ - j^-}{\phi^+ - \phi^-}$$

where j^+ and j^- are the currents at the right and left, respectively. ϕ^+ and ϕ^- are the similarly defined fluxes.

The transport equation is then solved inside the slab in order to find the surface fluxes and currents, producing the following equations for the blackness coefficients:

$$\alpha(E) = \frac{1 - 2E_3(Z)}{2[1 + 3E_4(Z)]} \quad (2-2)$$

$$\beta(E) = \frac{1 + 2E_3(Z)}{2[1 - 3E_4(Z)]}$$

where $Z = 2t\Sigma_a(E)$, and t is the slab's half-thickness. E_3 and E_4 are the exponential integrals defined as:

$$E_{n+2}(Z) = \int_0^1 \mu^n \exp\left[-\frac{Z}{\mu}\right] d\mu \quad (2-3)$$

(Reference 8 contains tables of these integral functions.)

For the thermal range, the functions $\alpha(E)$ and $\beta(E)$ are then averaged over the energy spectrum:

$$\langle \alpha \rangle_{th} = \frac{\int_0^E \alpha(E) \phi^\infty(E) dE}{\int_0^E \phi^\infty(E) dE} \quad (2-4)$$

$$\langle \beta \rangle_{th} = \frac{\int_0^E \beta(E) \phi^\infty(E) dE}{\int_0^E \phi^\infty(E) dE}$$

where E_c is the thermal cut-off energy, and $\phi^\infty(E)$ is the flux spectrum in the surrounding medium, away from the slab's surface. The value of $\langle \alpha \rangle_{th}$ provides a measure of the absorption ability of the slab. A value near zero would be very lightly absorbing, while the maximum value of 1/2 would represent a totally black absorber.

The equivalent diffusion theory parameters, $\bar{\Sigma}_a$ and \bar{D} , are obtained from the spectrum-weighted blackness coefficients by the use of the following equations:

$$\bar{\Sigma}_a = \frac{\sqrt{\langle \alpha \rangle \langle \beta \rangle}}{2t} \ln \frac{1 + \sqrt{\langle \alpha \rangle / \langle \beta \rangle}}{1 - \sqrt{\langle \alpha \rangle / \langle \beta \rangle}} \quad (2-5)$$

$$\bar{D}\bar{\Sigma}_a = \langle \alpha \rangle \langle \beta \rangle$$

When the blade is composed of layers of different materials, a homogenization correction must be considered. This was the case for the original design of the absorbers in the MITR-II, which were cadmium clad with aluminum. Values of $\bar{\Sigma}_a$ and \bar{D} were found for each material region, then combined in a manner which equated the thermal fluxes and currents at each internal interface. The result of this correction was to produce homogenized equivalent diffusion theory parameters for the blade as a whole.

Before inclusion into a finite-difference code such as CITATION, one additional correction must be made to the $\bar{\Sigma}_a$ and \bar{D} values. This correction compensates for the effect that the mesh

spacing which mocks up the blade region has on the blade's absorption.

The methods used to apply these two corrections were generated and written into a small computer program by Emrich (Reference 9). The segment of this program which deals with these corrections was isolated and modified for the following work. A listing and description of the required input of the modified code is given in Appendix A.

The original aluminum-clad, cadmium absorbers of the MITR-II were used successfully for approximately the first five months of the core's operation. After this period, swelling of the fixed and moveable absorbers was noted. It was therefore decided that the core would be operated for a time without fixed absorbers, and then eventually be refitted with hafnium fixed absorbers. The six moveable cadmium blades were replaced one by one with plates of 1.1% natural boron in stainless-steel. To accurately model prospective core configurations, it became necessary to develop equivalent diffusion theory parameters for the hafnium fixed absorbers, and boron-stainless steel moveable absorbers.

Hafnium Fixed Absorbers

The new fixed absorber design consists of twelve pure hafnium slab inserts held in position by the central spider assembly, as shown in Figure 2-1. Each slab is 0.1 inch thick, by 2 inches wide, by 12.3 inches long. With these absorbers in place, the active (unpoisoned) core height is twelve inches.

Values of $\langle \alpha \rangle_{th}$ and $\langle \beta \rangle_{th}$ were determined by employing the previously outlined method of weighting $\alpha(E)$ and $\beta(E)$ over the flux

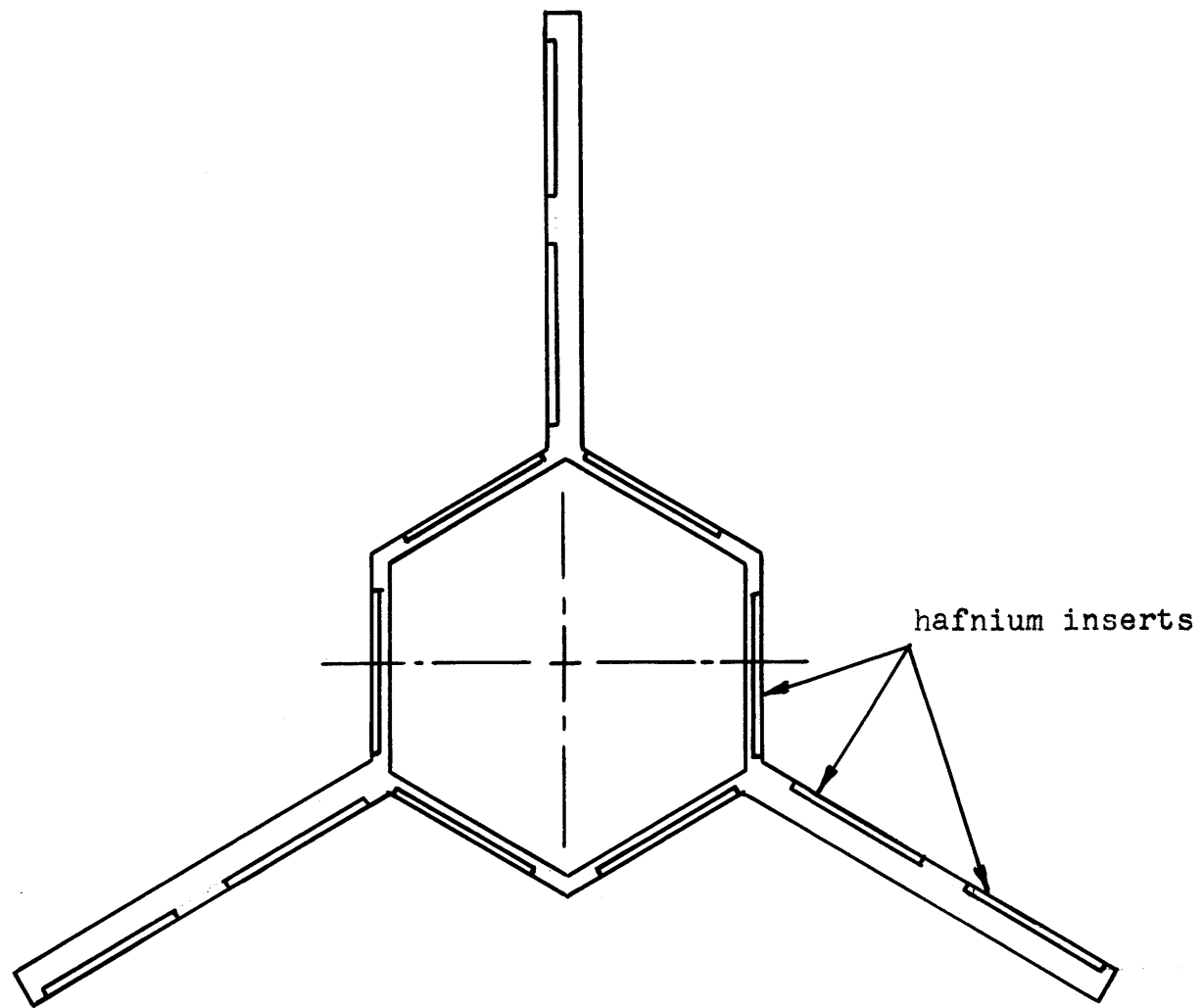

FIGURE 2-1. Horizontal section of the fixed absorber spider with hafnium inserts in place.

spectrum in the thermal range. $\bar{\Sigma}_a$ and \bar{D} were then found by use of the modification of Emrich's code which considered homogenization and mesh-spacing corrections.

It was also necessary to apply blackness theory in the epithermal energy range, due to the significant amount of resonance capture in hafnium. The technique used here was that of Henry, as detailed in Reference 7. In this work, $\langle \alpha \rangle_{\text{epi}}$ is shown to be given by:

$$\langle \alpha \rangle_{\text{epi}} = \frac{1}{\frac{\ln\left(\frac{3 \times 10^3}{.4}\right)}{I} - \sqrt{3}} \quad (2-6)$$

$$\text{where } I = \int_{.4}^{3 \times 10^3} \frac{\alpha(E)dE}{[1 + \sqrt{3} (E)]E} \quad (2-7)$$

The problem was then reduced to that of determining a value for I. To accomplish this, the epithermal energy range was broken up into three segments. The neutron absorption of each one was considered separately, and the contribution of each segment to the integral (I) was found.

In the first segment, .4 ev to 10 ev, BNL data (Reference 10) was applied to the first of equations (2-2) to obtain the function $\alpha(E)$. This function was then used to numerically integrate equation (2-7) over the .4 to 10 ev range.

For the second segment, 10 ev to 100 ev, the integration considered absorption due to isolated resonances through the use of Stein's method (Reference 11). The resonance parameters employed

in this analysis by Henry were obtained from Reference 10.

Additionally, a $1/v$ contribution based on $\sigma_a^{\text{Hf}} (.0253\text{ev}) = 105 \text{ b.}$, was included in this segment. In the third segment, from 100 ev to 3×10^3 ev, only a $1/v$ cross section was considered.

The individual contributions to I from the three segments were summed to give a total I . The value of $\langle \alpha \rangle_{\text{epi}}$ was determined from equation (2-6), then the homogenization and mesh-spacing corrections were applied to obtain the final values of $\bar{\Sigma}_a$ and \bar{D} .

Blackness theory was not required to accurately determine the fast neutron cross sections. A flux-weighting CITATION collapse run, as described in Section 2.1, was used in this energy range.

Boron-Stainless-Steel Control Blades

The new boron-stainless-steel shim blades are of the same outer dimensions as the old cadmium blades. Internally, each blade consists of two plates separated by a 0.05 inch water gap. Both plates are composed of 1.1 weight percent natural boron in type 304 stainless steel; Table 2-2 lists the blade's constituents and their densities. In developing the group cross-sections, the elements B, Fe, Cr, Ni, Mn, Si, and C were considered. The others were assumed to have a negligible effect due to their very low concentrations. The blackness theory technique described in the first part of section 2.2.2 was employed in the thermal range. Simple flux-weighting, by use of a CITATION collapse run, was adequate for the epithermal and fast groups.

TABLE 2-2
BORON-STAINLESS STEEL CONTROL BLADE COMPOSITION

Element	Weight Percent
B*	1.100
Fe	64.280
Cr	18.450
Ni	13.660
M _N	1.750
Si	.710
C	.040
P	.008
S	.004

*The 1.1% Boron consists of 18.41 atom percent B-10.

Aluminum-Clad Cadmium Absorbers

The original design of the control materials for the MITR-II consisted of aluminum-clad cadmium for both the fixed and moveable absorbers. The hexagonal fixed absorber, which surrounded the A-ring of elements was composed of a 0.020 inch thick cadmium plate covered with aluminum. The three radial fixed absorbers, and six moveable shim blades each consisted of a 0.040 inch thick plate of cadmium clad with aluminum.

The group cross sections for the cadmium absorbers were originally developed well before operation of the MITR-II reactor (References 3 & 17). In the epithermal and fast energy ranges, a fifteen group cadmium cross section set was collapsed into three group form in an EXTERMINATOR-II run. For the thermal range, a modified blackness theory approach was used. When using the cross section set obtained in this manner, it was noted that CITATION was consistently low in predicting K_{eff} . CITATION also underpredicted the thermal flux and power levels of the upper core region, which is the area most affected by the cadmium absorbers. These facts suggested that the cadmium absorption cross sections were too large, causing an unrealistically strong flux depression in the upper core. A new three group cadmium cross section set was therefore generated. For the epithermal and fast energy ranges, a new fifteen group cadmium cross section set was used in a CITATION collapse code. This procedure produced a significantly smaller fast neutron absorption cross section, and a slightly smaller epithermal absorption cross section. For the thermal range, the blackness theory method presented at the beginning of section 2.2.2 was employed. The result was a greatly reduced thermal absorption cross section.

It was found that the new three group set produced a K_{eff} in closer agreement with experiment than the old set. For a representative case*, the new K_{eff} prediction was low by 1%, as compared with an underprediction of 4.2% with the old cross section set. The new set also resulted in more realistic axial power and flux distributions in the core. The thermal flux levels in the beam ports were also affected by the change; the newly calculated flux showed a 12% drop from the old predictions.

Appendix B contains additional comparisons between results obtained with the old and new cadmium cross section sets, and compares these results with empirically determined data. It also includes the results of a calculation which mocks up an expected future core configuration of three aluminum dummies in place, and hafnium fixed absorbers at a height of 12 inches.

2.2.3 Steel and Molybdenum Cross Sections

Chapters 4, 5 and 6 are concerned with the analysis of facilities which will allow the in-core irradiation of various samples. Two of the materials envisioned for irradiation in these facilities are molybdenum and steel. Molybdenum-98 undergoes a neutron capture reaction which produces the gamma emitter technetium-99m, a nuclide useful in cancer detection. The irradiation of steel samples is useful in the study of neutron damage on steel's material properties.

*24 fueled elements, 2 aluminum dummies, and old in-core sample assembly in place. Fixed cadmium absorbers at a height of 10 inches, and cadmium blades at a height of 10 inches.

In order to represent these materials in the CITATION code, it was necessary to develop their three group cross-sections. The epithermal and fast cross sections were generated by a CITATION collapse run from a fifteen group set. The thermal cross sections were flux-weighted over the flux spectrum obtained from the THERMOS code. A533 (Type B) steel, which is used for light water pressure vessels, was the steel sample modeled; its composition is noted in Table 2-3.

TABLE 2-3
COMPOSITION OF A533 (TYPE B) STEEL SAMPLE

Element	Weight Percent
Fe	97.10
Mn	1.30
Ni	.55
Mo	.50
C	.25
Si	.22
P	.04
S	.04

CHAPTER 3

SAFETY LIMIT AND LIMITING CONDITION FOR OPERATION

The safety limit and limiting condition for operation provide a conservative means of insuring that incipient boiling will not occur at any point in the core. If boiling is prevented, burnout can not occur, and the structural integrity of the fuel cladding will be maintained.

Derivations of these limits can be found in the MITR-II Safety Analysis Report (Reference 12). The definitions and evaluation procedures which are contained in the following sections have been drawn from the MITR-II Technical Specifications (Reference 13), and a report by Allen entitled "The Reactor Engineering of the MITR-II Construction and Startup" (Reference 14).

3.1 SAFETY LIMIT

The safety limit is defined as:

$$\text{Safety Limit} \equiv F_{HC} F_P / F_F d_F$$

where $F_{HC} = F_H(F_R)_{\max}$, and $d_F = d_{FC} d_{FP}$.

The meanings of the various terms are as follows:

F_H - Hot channel enthalpy factor. This term considers uncertainties in reactor power and power density measurement, fuel density, eccentricity, and flow measurement.

F_R - Radial peaking factor, the ratio of the power produced in a particular plate to the power produced in the average plate in the core.

F_{HC} - Hot channel factor, the ratio of the power released into the hottest channel to the power released into the average core channel.

F_F - Fraction of the primary coolant which actually cools the fuel.

F_P - Fraction of the total power generated by the fuel.

d_{FC} - Channel flow disparity. This term considers the maldistribution of flow among the channels of a single element.

d_{FP} - Plenum flow disparity. This considers flow maldistribution among the fuel elements for a particular core configuration.

d_F - Flow disparity, the ratio of the coolant flow through the hot channel to the flow through the average channel in the core.

The safety limit must always be less than or equal to 2.9 at all points in the core.

3.2 LIMITING CONDITION FOR OPERATION

The limiting condition for operation, or operating limit, is defined as follows:

$$\text{Operating Limit} \equiv \left[\left(\frac{W_T}{W_{TO}} \right)^2 G + \frac{F_P F_R Z F'_O}{d_F F_F} - 1 \right] - 2.77 \left[\frac{P_T F_R F_A}{\eta A} \right]^{.466}$$

where

$$G \equiv \frac{F_R F_A F_P}{\eta (F_F d_F)^2} \left(\frac{W_{TO} C_P}{h_o A} \right) F'_O, \text{ and } d_F = d_{FC} d_{FP}.$$

The terms are defined as follows:

W_T - Total coolant flow rate in gallons/minute.

W_{TO} - Two pump coolant flow rate (1800 gallons/minute).

Z - Axial location factor. This is the ratio of the power released into the channel containing the hot spot between the inlet and the hot spot, to the total power released into the channel.

F'_O - Uncertainty factor in determining $F_R Z$ and in the flow measurement.

P_T - Limiting safety system setting of the reactor power (MW).

F_A - Axial peaking factor, the ratio of the power density in a plate at a certain height to the average power density in the plate.

η - Cladding fin effectiveness, ratio of finned plate heat transfer to unfinned plate heat transfer.

- A - Total heat transfer area of the fuel meat (not cladding surface) in ft^2 .
- C_p - Coolant heat capacity in $\text{BTU}/\text{lb}\text{-}^\circ\text{F}$.
- h_o - Normalized heat transfer coefficient for a particular core configuration in $\text{BTU}/\text{hr}\text{-}\text{ft}^2\text{-}^\circ\text{F}$.
- F_o - Uncertainty factor in fuel density tolerances and in determining the reactor power, power density, flow, heat transfer coefficient, and fin effectiveness.

The maximum value of the operating limit in the core must be less than or equal to 3.72 in order to allow operation above a reactor power of 1 KW.

3.3 EVALUATION OF THE SAFETY AND OPERATING LIMITS

The various factors needed to determine the safety and operating limits were evaluated by Allen (Reference 14). Table 3-1 lists these factors for three dummy and five dummy core configurations, and for one and two pump operation. Table 3-2 shows the experimentally determined value of d_{fp} for each fueled position in the three and five dummy cores used in the MITR-II.

In order to find values for the remaining factors (F_R , F_A , and Z), the power distribution of the core must be known. A CITATION calculation or a plate gamma-scanning procedure can be used to gain this information. Care must be taken however, when CITATION data are used. It has been found that the F_R , F_A , and Z values predicted by CITATION are, in some

TABLE 3-1

FACTORS USED IN SAFETY AND OPERATING LIMIT EVALUATION

Factor	Value for 3-Dummy Core	Value for 5-Dummy Core
F_H	1.211	1.211
F_P	1.0	1.0
F_f	.9487	.9205
d_{fC}	.887	.887
W_{T_o}	8.91×10^5 lbm/hr	8.91×10^5 lbm/hr
W_T/W_{T_o} (for 2 pump operation)	1.0	1.0
W_T/W_{T_o} (for 1 pump operation)	.5	.5
F'_o	1.122	1.122
n	1.9	1.9
A	232.9 ft ²	213.5 ft ²
P_T (for 2 pump operation)	6.0 MW	6.0 MW
P_T (for 1 pump operation)	3.0 MW	3.0 MW
C_P	.9985 BTU/lb-°F	.9985 BTU/lb°F
h_o	2585 BTU/hr-ft ² -°F	2771 BTU/hr-ft ² -°F
F_o	1.55	1.55

TABLE 3-2

VALUES OF PLENUM FLOW DISPARITY (d_{fp}) FOR THREE AND FIVE
DUMMY CORE CONFIGURATIONS:

3 dummy core - dummies in positions A-1, B-2, and B-8

5 dummy core - dummies in positions A-2, A-3, B-3, B-6 and B-9

<u>Core Position</u>	<u>Value for 3-Dummy Core</u>	<u>Value for 5-Dummy Core</u>
A-1	*	1.009
A-2	1.017	*
A-3	.986	*
B-1	1.049	1.074
B-2	*	1.049
B-3	.997	*
B-4	1.007	1.032
B-5	1.057	1.058
B-6	1.073	*
B-7	1.082	1.084
B-8	*	1.032
B-9	1.092	*
C-1	.942	.989
C-2	.960	.930
C-3	.981	.951
C-4	.977	.949
C-5	*	*
C-6	*	*
C-7	.945	.954
C-8	1.011	.993
C-9	.938	.953
C-10	.981	1.019
C-11	.985	1.009
C-12	.946	.944
C-13	.997	.944
C-14	1.025	.972
C-15	1.001	1.036

*Aluminum dummy location or above-core obstruction prevented values being taken for these positions.

instances, below the more reliable gamma-scan values. These underpredictions are most pronounced in areas where local conditions influence a single plate, such as near a water-filled channel. This is mainly due to the fact that the computer models which are employed can only approximate the true shape of the core power distribution. They can not give detailed power densities at each point in the core, such as can be obtained by a gamma scan procedure. More detailed CITATION results can be obtained by increasing the number of core mesh points, but if carried too far, the limitations of computer costs and computer memory size are eventually encountered.

The degree by which CITATION underpredicts the three power distribution factors depends upon the core configuration and core region being considered. Core power data, some of which have been obtained from Reference 14, are listed in Tables 3-3 and 3-4. The first compares experimentally determined (gamma-scan) values with those obtained from CITATION calculations, for two positions in a three dummy core. For the A-ring, the configuration which is compared includes the old in-core sample assembly (the old cadmium cross section set was used in the CITATION calculation). For the C-ring, the three solid aluminum dummy configuration was considered; the new cadmium cross section set was used here. The second table considers a five dummy core and compares F_R values developed from a conservative combination of gamma-scan data and CITATION data, with values from CITATION data only. "CITATION-only" estimates of F_A and Z are compared against gamma-scan values for these factors. Listed for each pair of F_R , F_A , and Z values is a prediction factor which is the ratio of the experimental value to the "CITATION-only" value.

TABLE 3-3

Comparison of experimentally determined, and computer generated values of F_R , F_A , and Z for a THREE-DUMMY core configuration*.

Core Position A-2, next to old in-core sample assembly:

F_R : gamma-scan value⁺ = 2.13
 "CITATION-only" value⁺⁺ = 1.571
 prediction factor = 1.356

Height above fuel bottom (inches)	F_A			Z		
	Gam- Scan ⁺	CIT ⁺⁺	Pred. Factor	Gam- Scan ⁺	CIT ⁺⁺	Pred. Factor
0	1.573	1.988	.791	.000	.000	1.000
1.1	1.211	1.813	.668	.068	.084	.810
2.1	1.174	1.685	.697	.122	.161	.758
6.1	1.329	1.645	.808	.345	.413	.835
8.0	1.451	1.617	.897	.463	.553	.837
10.0	1.413	1.335	1.058	.594	.679	.875
14.0	.864	.738	1.171	.796	.834	.954
16.0	.690	.570	1.211	.866	.888	.975
19.0	.498	.388	1.284	.946	.945	1.001
24.0	.291	.263	1.106	1.000	1.000	1.000

An average of the inner two CITATION channels (for $\theta=6$) was used to obtain the "CITATION-only" values (old Cd cross sections were used in CITATION run).

Core Position C-8, at edge of core:

F_R : gamma-scan value⁺ = 1.527
 "CITATION-only" value⁺⁺ = 1.341
 prediction factor = 1.139

Height above fuel bottom (inches)	F_A			Z		
	Gam- Scan ⁺	CIT ⁺⁺	Pred. Factor	Gam- Scan ⁺	CIT ⁺⁺	Pred. Factor
0	2.200	2.440	.902	.000	.000	1.000
1.1	1.611	2.172	.742	.076	.102	.745
2.1	1.755	2.028	.865	.146	.192	.760
6.1	1.846	1.736	1.063	.453	.520	.871
8.0	1.630	1.334	1.222	.591	.652	.906
10.0	1.224	.945	1.295	.711	.739	.962
14.0	.687	.565	1.216	.866	.858	1.009
16.0	.514	.450	1.142	.916	.899	1.019
19.0	.321	.339	.947	.968	.947	1.022
24.0	.170	.254	.669	1.000	1.000	1.000

The outer CITATION channel ($\theta=11$) was used to obtain the "CITATION-only" values (new Cd cross sections were used in CITATION run).

(Footnote explanations on following page)

*Dummies in A-1, B-2, and B-8, Cd fixed absorbers at 10".
Many of these data are from Reference 14.

+Experimental data from gamma-scanning, blade height = 7.6 inches.

++"CITATION-only" values obtained from computer analysis, blade height
= 8.0 inches.

TABLE 3-4

Comparison of experimentally determined, and computer-generated (with old Cd cross section data) values of F_R , F_A , and Z for a FIVE-DUMMY core configuration*.

Core Position A-1, next to solid dummy:

F_R : gamma-scan & CITATION value⁺ = 1.430
 "CITATION-only" value⁺⁺ = 1.250
 prediction factor¹ = 1.144

Height above fuel bottom (inches)	F_A			Z		
	Gam- Scan**	CIT ⁺⁺	Pred. Factor	Gam- Scan**	CIT ⁺⁺	Pred. Factor
0	1.250	1.709	.731	.000	.000	1.000
1.1	1.000	1.516	.660	.062	.071	.866
2.1	.980	1.341	.731	.110	.134	.821
6.1	1.075	1.027	1.047	.295	.307	.961
8.0	1.085	1.015	1.069	.388	.391	.992
10.0	1.145	1.038	1.103	.492	.474	1.038
14.0	1.150	1.023	1.124	.720	.655	1.099
16.0	1.035	.953	1.086	.877	.738	1.188
19.0	.730	.831	.878	.949	.849	1.118
24.0	.715	.727	.983	1.000	1.000	1.000

(An average of the inner two CITATION channels (for $\theta=5$) was used to obtain the "CITATION-only" values.)

Core Position C-13, at edge of core:

F_R : gamma-scan & CITATION value⁺ = 1.54
 "CITATION-only" value⁺⁺ = 1.191
 prediction factor¹ = 1.293

Height above fuel bottom (inches)	F_A			Z		
	Gam- Scan**	CIT ⁺⁺	Pred. Factor	Gam- Scan*	CIT ⁺⁺	Pred. Factor
0	1.79	2.238	.800	.000	.000	1.000
1.1	1.35	1.977	.683	.067	.093	.720
2.1	1.43	1.833	.780	.126	.175	.720
6.1	1.61	1.576	1.022	.382	.469	.814
8.0	1.58	1.259	1.255	.510	.590	.910
10.0	1.42	.965	1.426	.636	.676	.966
14.0	.82	.667	1.229	.825	.809	1.020
16.0	.65	.567	1.146	.887	.859	1.033
19.0	.39	.460	.848	.953	.923	1.033
24.0	.28	.370	.757	1.000	1.000	1.000

(The outer CITATION channel ($\theta = 5$) was used to obtain the "CITATION-only" values.)

(Footnote explanations on following page)

*Dummies in A-2, A-3, B-3, B-6, & B-9, no fixed absorbers. Many of these data are from Reference 14.

**Experimental data from gamma-scanning, blade height = 8.6 inches.

†Values obtained from a conservative combination of gamma-scan and CITATION data.

††"CITATION-only" values obtained from computer analysis, blade height = 8.0 inches. (Old cross section set used.)

¹These prediction factors include the conservatism used in combining the gamma-scan and CITATION Information.

A larger A-ring prediction factor for F_R is seen to result in the three dummy core as compared to the five dummy core. This is partly due to the different mesh spacing arrangements employed in modelling these configurations. The widths of the fueled mesh regions which are used in developing the three-dummy factors are approximately three times as large as for the five dummy case. Therefore, the three-dummy "CITATION-only" value averages further into the cooler region toward the centerline of the element. When this CITATION prediction is compared against the experimental value for the hot plate at the element's edge, a large prediction factor for F_R results.

A short code was written to estimate the safety and operating limits by using computer-generated power density data and the prediction factors given in Tables 3-3 and 3-4. The CITATION information provides estimates of the three core power distribution factors. These factors are then multiplied by the correct prediction factors (depending upon the core geometry and core location considered) before they are used in the safety and operating limit equations. Appendix C presents a listing of this code and explains the required input procedure.

CHAPTER 4

SINGLE ELEMENT IRRADIATION FACILITIES

The two initial designs of in-core sample holders were developed to make use of a single core position. This chapter provides a description and evaluation of the original single element assembly designed by Soth (Reference 15), and of the subsequent modification made to this design.

4.1 ORIGINAL IN-CORE SAMPLE ASSEMBLY

The original in-core sample assembly (ICSA) had been designed and constructed before the completion of the reactor modification. This assembly is pictured in Figure 4-1. Its external dimensions are those of a typical fuel element, allowing installation into any of the twenty-seven core positions. Internally, it consists of a 1.25 inch O.D. sample tube reaching partway down its length, and surrounded by a .425 inch thick annular coolant gap. Below the sample tube is a 1.25 inch diameter coolant channel. The assembly's body is composed of aluminum.

This ICSA was used to hold a neutron source during startup testing of the MITR-II. It was later in place for some of the low power physics tests, including the initial gamma-scanning procedures. During these tests however, it was determined that the ICSA's water channel was producing an unacceptable power peaking in adjacent fuel plates. This analysis was performed

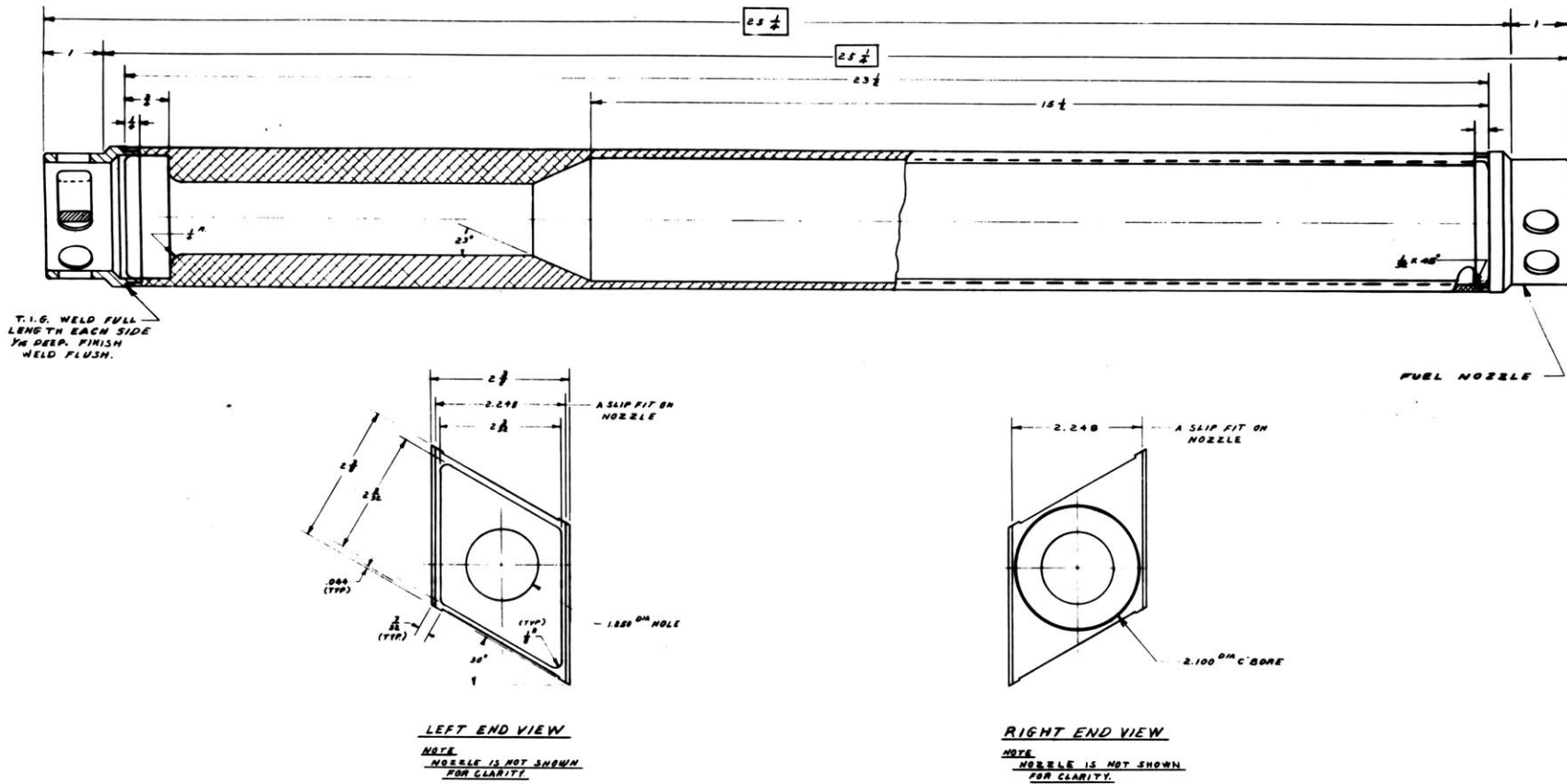

FIGURE 4-1. Original in-core sample assembly design

by Allen and is detailed in Reference 14. His work showed that a safety limit of 2.88 was reached. This is very close to, but still below the maximum allowed value of 2.9. However, the operating limit reached a value of 5.07, well above the 3.72 limit allowed for operation above 1 KW. Therefore, the initial ICOSA design could not be employed at higher reactor powers. In order to alleviate this power peaking problem, the ICOSA was modified into an assembly called the molybdenum sample holder.

4.2 MOLYBDENUM SAMPLE HOLDER

The design of the molybdenum sample holder eliminated much of the coolant volume which the old ICOSA contained. This was accomplished by adding aluminum to the assembly's body and lengthening the sample tube to a point slightly below the fuel bottom. Figure 4-2 shows this new design. The central sample tube is surrounded by a .05 inch annular coolant gap running the length of the assembly. An aluminum insert was placed into the upper portion of the original ICOSA's housing to reduce the coolant gap to the desired size.

Several three-group CITATION calculations were performed to determine if power peaking would be a problem with the molybdenum sample holder design. The reactivity effect of flooding the sample tube was also found.

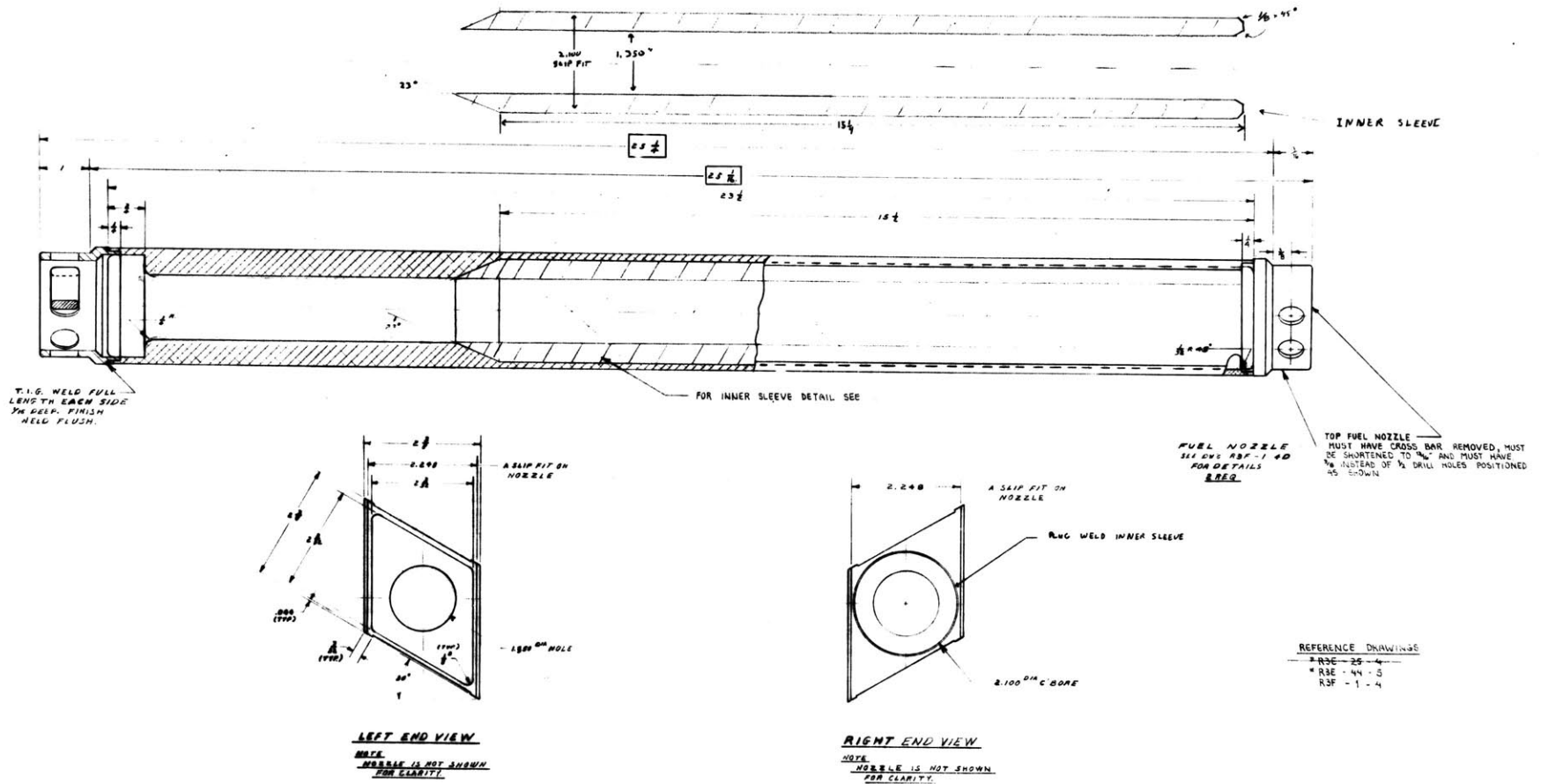

FIGURE 4-2. Molybdenum sample holder design.

The core configuration for which this computer analysis was conducted was that of a five dummy core (four solid dummies plus the sample holder), without fixed absorbers. A three-dimensional (R, θ , Z) core model was used; this mockup was based on work by Yeung (Reference 16), and is depicted in Figure 4-3. This figure shows a horizontal cross section of the core with the radial and azimuthal mesh spacings. Only one-half of the core is mocked up; a plane of symmetry is assumed through the regulating rod and core centerline. Axially, the fueled region is divided into nine planes. Two more planes are located above these nine to model the structure and coolant located above the fuel. Nine planes are located below the fuel. The moveable cadmium control blades in this study were mocked up by the use of the original set of cadmium blade cross sections as described in Section 2.2.2.

The reactivity effect of flooding the sample tube was found first. Although the sample assembly would be physically located in either core position A-2 or A-3, it was impossible to represent this situation with the half-core computer model being used. The sample tube was therefore mocked up as being located halfway between the midpoints of core positions A-2 and A-3. Two CITATION cases were then run with the cadmium control blades at a height of 8 inches and a core power of 5 MW. The first mocked up a voided sample tube and resulted in a K_{eff} of .9550. In the second run, the void was replaced by water, resulting in a K_{eff} of .9569.

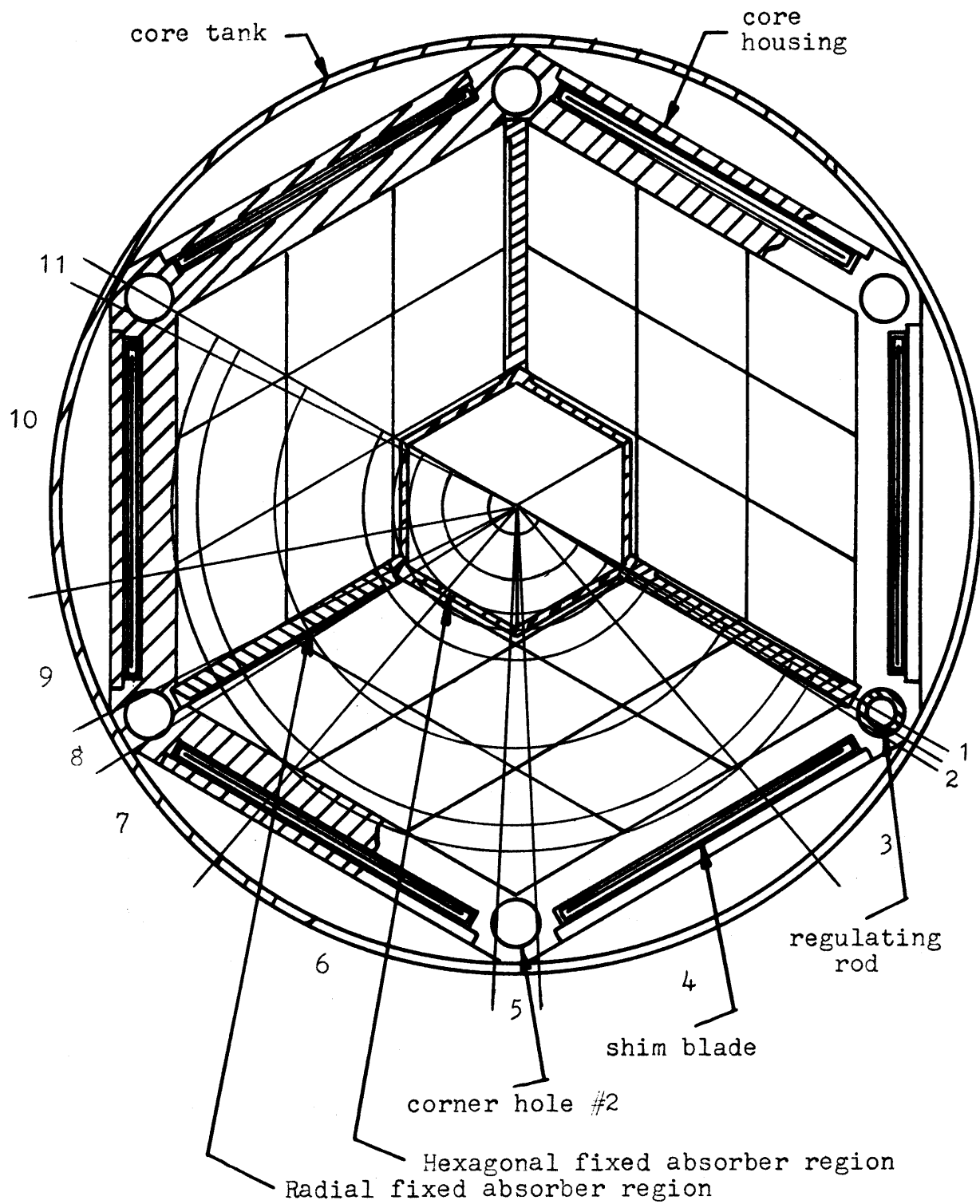

FIGURE 4-3. Horizontal section showing core model for molybdenum sample holder.

The reactivity effect of flooding was therefore estimated to be 0.19% ΔK . This prediction was confirmed when low power testing of the assembly took place. The reactivity effect of removing the voided sample tube and leaving a water-filled channel in the center of the assembly was measured to be 0.19% ΔK , the same as the predicted value.

The technical specification limits for the voided tube mockup were calculated from the CITATION power density output; this information is listed as case 1 of Table 4-1. It can be seen that for this computer mockup, the limits are within their allowed ranges. The maximum safety limit of 2.19 occurred in position A-1, next to the sample assembly, while the maximum operating limit of 3.17 occurred at the edge of the core in position C-13. The prediction factors for a five dummy core (Table 3-4) were used in this analysis.

CITATION calculations were also performed to evaluate the technical specification limits for the sample holder in a flooded condition at two shim blade heights. A slightly different approach was used in modelling these computer runs. Because of the symmetry condition imposed by the half-core model, the equivalent of one-half of a flooded sample tube was included in both positions A-2 and A-3. The first case run with this core mockup positioned the blades at a height of 8 inches. The second case was for a 14 inch blade height. The results of these calculations are shown as the second and third cases in Table 4-1.

TABLE 4-1

RESULTS OF LIMIT CALCULATIONS FOR THE MOLYBDENUM SAMPLE HOLDER

Case	Core Configuration	K _{eff} ⁺⁺	Max. Safety Limit		Max. Operating Limit					
			value	position	value	position	height (inches)	F _R	F _A	Z
1*	4 dummies & voided sample holder, Cd blades at 8"	.9550	2.19	A-1, next to moly holder	3.17**	C-13, at edge of core	8	1.52	1.84	.51
2*	4 dummies & flooded sample holder, Cd blades at 8"	.9581	2.59	A-1, next to moly holder	3.26**	A-1, next to moly holder	16	1.76	1.06	.87
3	4 dummies & flooded sample holder, Cd blades at 14"	1.0314	2.71	C-13, at edge of core	3.89 ¹	C-2, at edge of core	10	1.58	1.83	.64
4 ⁺	2 dummies & flooded sample holder, B-SS blades at 8", Hf fixed at 12"	.9938	2.74	A-3, next to moly holder	3.40**	A-3, next to moly holder	10	1.88	1.35	.56

*The technical specification limits obtained for these cases have been estimated by use of the prediction factors listed in Table 3-4.

⁺The technical specification limits obtained for this case have been estimated by use of the prediction factors listed in Table 3-3.

⁺⁺Different core mockups were used for these cases (except for cases 2 & 3), it is therefore not strictly appropriate to compare these values.

**For 5MW (2 pump) operation.

¹This value is the predicted 2.5 MW (1 pump) operating limit, the predicted shim blade height at which the 3.72 limit is reached is 13.6 inches.

The "CITATION-only" results generated from these computer calculations showed the safety and operating limits for both cases to be below the maximum allowed values of 2.9 and 3.72, respectively. However, when the prediction factors from the five dummy core (Table 3-4) are applied to the "CITATION-only" results, the operating limit for the 14-inch case exceeds its maximum allowed value of 3.72. The condition at which the operating limit is predicted to reach 3.72 is with the blades raised to a height of 13.6 inches.

Cases 1, 2, and 3 were performed for a core containing the molybdenum sample holder, four aluminum dummies, cadmium shim blades, and no fixed absorbers. In order to evaluate the power peaking effect of introducing hafnium fixed absorbers and boron-stainless-steel shim blades, a fourth case was performed. This calculation positioned dummies in positions B-2 and B-8, with a flooded sample assembly in position A-1. The fixed and moveable absorbers were at heights of 12 and 8 inches, respectively, and the reactor power was again set at 5 MW. The core model used for this case was based on previous work by Allen (Reference 14) and is similar to the model described earlier in this section. The output of this computer run, along with an updated listing of the CITATION three group cross section library is provided in Appendix D.

The results of this calculation are shown as case 4 of Table 4-1. The prediction factors employed are from the three dummy configurations of Table 3-3. Maximum values of each limit occurred in the A-3 position, adjacent to the flooded sample assembly. The safety limit reached a value of 2.74, which is below the maximum allowed limit of 2.9. The

largest estimated operating limit was 3.40, which is below its maximum allowed value of 3.72. (In obtaining these limits, the power densities of the two inner CITATION channels which border the facility were averaged.)

Table 4-2 shows the thermal flux levels at two locations for the four cases considered. The first column lists the flux values at a point along the core centerline at the height of the beam ports. This indicates the magnitude of the flux which drives the beam ports. The second column shows the maximum thermal flux encountered within the sample assemblies.

Table 4-2

Results of CITATION thermal flux calculations
for the molybdenum sample holder

<u>Case</u>	<u>Description</u>	<u>Beam Port Thermal Flux (n/cm²sec)</u>	<u>Max. Sample Assembly Thermal Flux (n/cm²sec)</u>
1	4 dummies & voided sample holder, Cd blades at 8"	8.5×10^{13}	5.4×10^{13}
2	4 dummies & flooded sample holder, Cd blades at 8"	8.4×10^{13}	7.8×10^{13}
3	4 dummies & flooded sample holder, Cd blades at 14"	7.5×10^{13}	6.8×10^{13}
4	2 dummies & flooded sample holder, B-SS blades at 8", Hf fixed at 12"	9.3×10^{13}	8.5×10^{13}

This peak occurs at the bottom of the sample tube for each case.

These results demonstrate the influence that the control materials exert in pushing the thermal flux toward the bottom of the core. The maximum flux values at lower core positions are obtained when fixed absorbers are present, and the moveable absorbers are at the lower height.

CHAPTER 5

DOUBLE ELEMENT IRRADIATION FACILITY

The single element facilities discussed in the previous chapter allow for the irradiation of samples only up to 1.13 inches in diameter. Larger samples can be inserted into the beam ports, but the flux there is lower and much more thermalized than in the core. A larger facility was therefore investigated which would make use of two A-ring core positions.

This facility was designed to include a channel for the irradiation of a large rectangular sample, and a smaller channel containing a 1.25 inch O.D. sample tube. The layout can be seen in the horizontal cross section of the A-ring positions as shown in Figure 5-1. The aluminum body of the facility consists of two individual pieces. When placed together into adjacent A-ring positions, they form a large channel that is about 2.2 inches by 2.5 inches in cross section. The smaller sample channel is entirely contained by one of the aluminum pieces.

A steel sample is initially envisioned for irradiation in the large channel as part of a study of radiation damage effects. The smaller channel will be useful for the irradiation of molybdenum samples. These two materials were therefore included in the analysis of the double element facility in regard to reactivity effects, power peaking, and attainable fluxes.

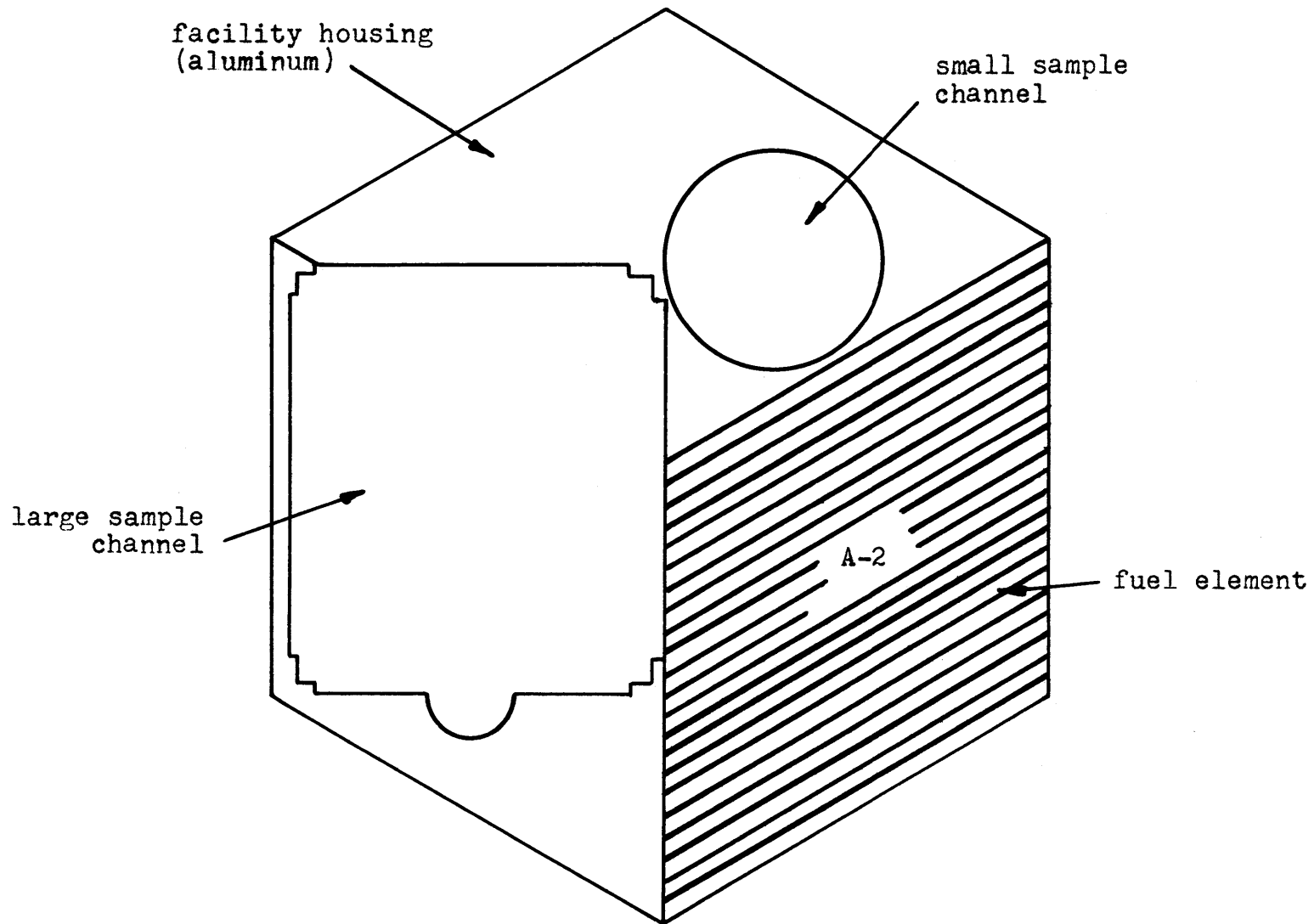

FIGURE 5-1. Horizontal cross section of A-ring core positions with double element facility in place.

5.1 FIFTEEN GROUP CITATION STUDY

The fast neutron flux is important to the investigation of radiation damage. It was therefore decided to perform a fifteen group study in order to obtain a detailed picture of the high energy flux spectrum. Two CITATION cases were considered, each using a two-dimensional (R,Z) core model. The first was a base case in which the three central elements were replaced by a mixture of 90% aluminum and 10% water. Fuel was placed in all other core positions. The second case included a 90% steel and 10% water, cylindrical sample, equal in cross sectional area to a single fuel element. It was located along the core centerline and ran the length of the fuel. Hafnium fixed absorbers were included at a height of 12 inches, and the boron-stainless-steel moveable blades were placed at 8 inches for both cases. The mesh spacing and zone compositions employed are shown in Figure 5-2. Table 5-1 lists the materials contained in each zone.

The base case K_{eff} was found to be 1.063. With the introduction of the steel sample, this value fell to 1.051, showing a reactivity effect of $1.2\% \Delta K$. The steel sample also produced an 8% drop in the thermal flux levels near the tips of the beam ports.

The component of the neutron flux above .9 mev is plotted in Figure 5-3 for the steel sample region. This curve shows the radial average of the fast flux across the steel sample as a function of axial position. The peak of 5.2×10^{13} n/cm²sec occurs at a point approximately half-way up the active core.

FIGURE 5-2. Two-dimensional core model used for fifteen group steel sample calculations. (not to scale)

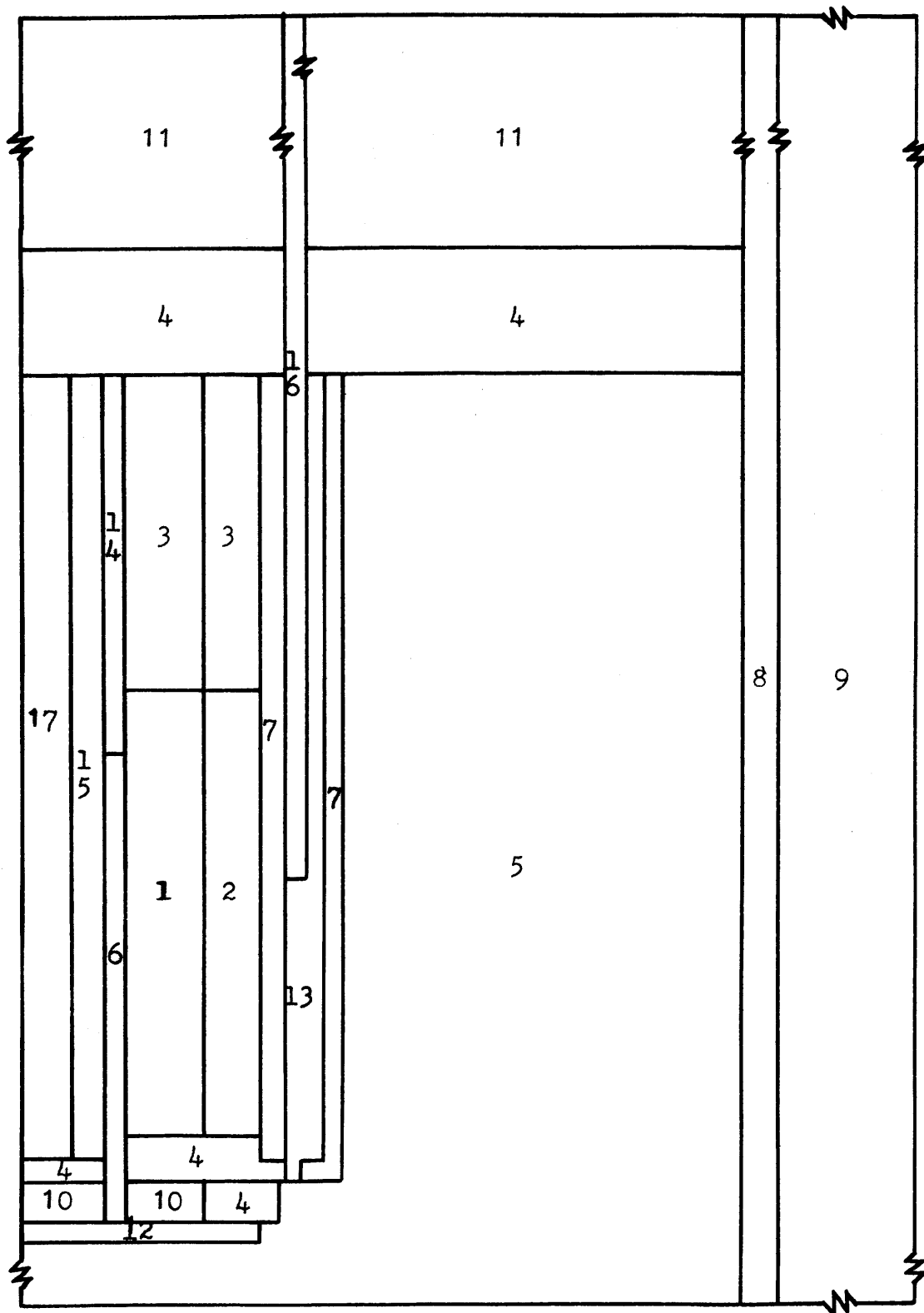

TABLE 5-1

ZONE COMPOSITIONS FOR 15 GROUP STEEL SAMPLE CALCULATION

<u>Zone</u>	<u>Nuclide Number</u>	<u>Nuclide Name</u>	<u>Number Density (atoms/cm-b)</u>
1	1	U-235	4.390×10^{-4}
	2	U-238	3.359×10^{-5}
	3	Al	3.183×10^{-2}
	4	H ₂ O	1.545×10^{-2}
2	5	U-235	4.390×10^{-4}
	6	U-238	3.359×10^{-5}
	7	Al	3.183×10^{-2}
	8	H ₂ O	1.545×10^{-2}
3	9	U-235	4.390×10^{-4}
	10	U-238	3.359×10^{-5}
	11	Al	3.183×10^{-2}
	12	H ₂ O	1.545×10^{-2}
4	13	Al	3.012×10^{-2}
	14	H ₂ O	1.655×10^{-2}
5	13	Al	1.621×10^{-4}
	14	H ₂ O	1.645×10^{-4}
	15	D ₂ O	3.275×10^{-2}
6	16	Al	6.023×10^{-2}
7	17	Al	6.023×10^{-2}
8	13	Al	3.012×10^{-2}
	14	H ₂ O	1.655×10^{-2}
9	18	C	8.344×10^{-2}
10	13	Al	3.120×10^{-2}
	15	D ₂ O	1.654×10^{-2}
11-13	14	H ₂ O	3.340×10^{-2}
14	13	Al	4.455×10^{-2}
	19	Hf	3.188×10^{-2}
15	14	H ₂ O	3.340×10^{-3}
	17	Al	5.421×10^{-2}

<u>Zone</u>	<u>Nuclide Number</u>	<u>Nuclide Name</u>	<u>Number Density (atoms/cm-b)</u>
16*	20	B	9.745×10^{-4}
	21	Fe	5.543×10^{-2}
	22	Cr	1.710×10^{-2}
	23	Ni	1.121×10^{-2}
17**	14	H ₂ O	3.340×10^{-3}
	18	C	7.561×10^{-2}
	21	Fe	8.900×10^{-4}
	23	Ni	3.800×10^{-4}

*The collapsing run to 3 groups for the B-SS blades also included the nuclides: Mn, Si, and C.

**The collapsing run to 3 groups for the steel sample also included the nuclides: Mn, Si, and Mo; also, it excluded H₂O.

FIGURE 5-3. Fast (above .9mev) flux (radially averaged across steel sample) as a function of axial position.

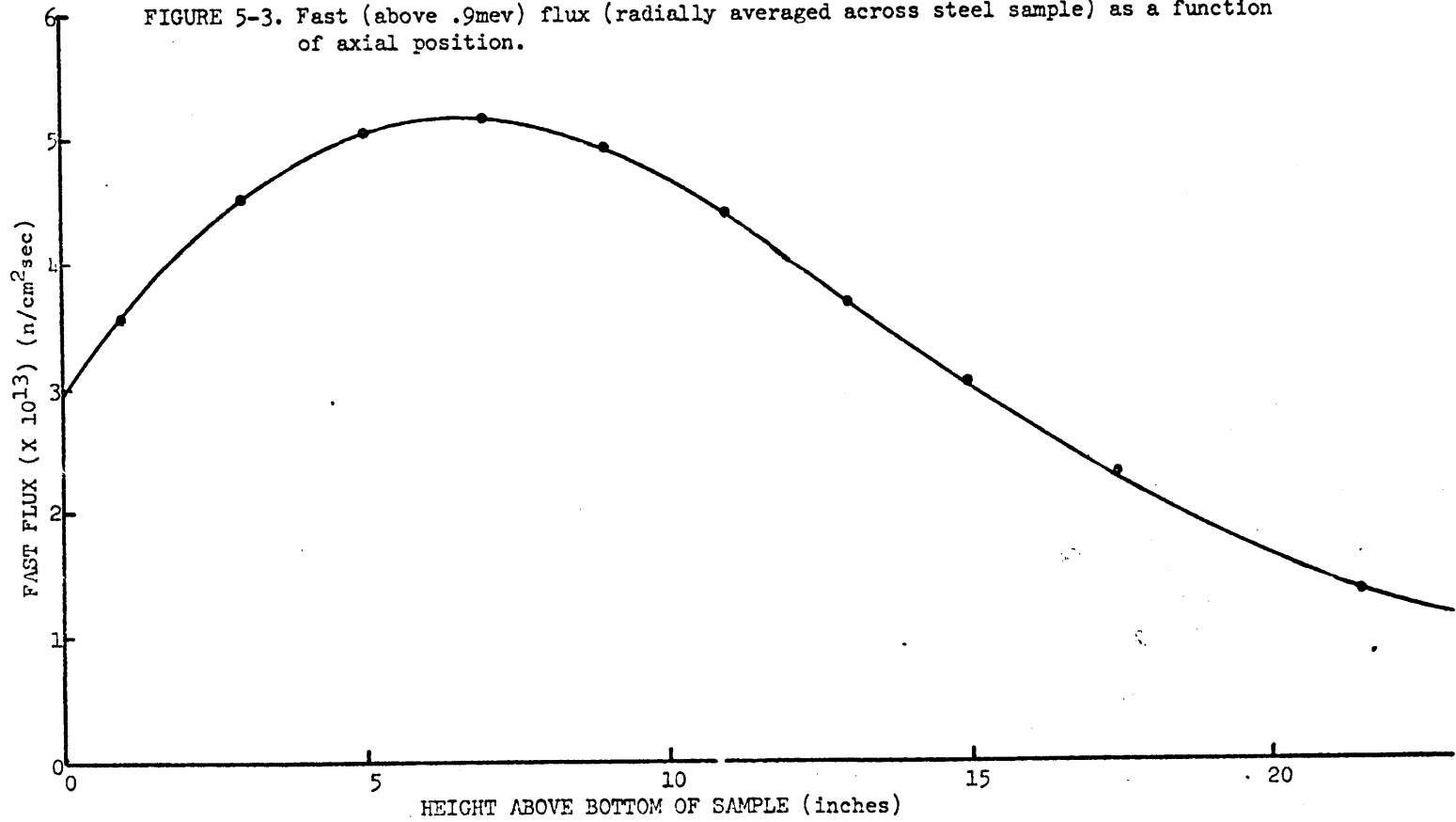

5.2 THREE GROUP CITATION STUDY

Following the fifteen group study, a three group, three-dimensional model was used to allow for a detailed spatial analysis of the double element facility. Estimates of the safety and operating limits, fluxes, and reactivity effects were found.

Due to the asymmetric nature of the facility, it was decided to abandon the half-core model which had been used in all previous three-dimensional runs. A full core model was employed as shown in the horizontal cross section of Figure 5-4. The core configuration assumed for this analysis consisted of the double element facility located in core positions A-1 and A-3. The A-2 position was fueled, and the B-4 position was filled with a solid dummy. The hafnium fixed absorbers were at a height of 12 inches, while the boron-stainless-steel blades were at 8 inches.

The first CITATION case included steel and molybdenum samples in the large and small channels, respectively. In the axial direction, the steel sample extended upward ten inches from a point two inches above the fuel bottom. The major part of the channel above the steel was filled with aluminum, and below the steel was an aluminum-water mixture. A molybdenum sample, in the form of MoO_3 at its theoretical density, extended upward 10.75 inches from a point .75 inch below the fuel bottom. The sample tube volume above the molybdenum was voided.

Two additional cases were computed. The first of these considered the removal of the steel sample and aluminum plug above the sample, and replaced these volumes with water. This run modeled the hypothetical

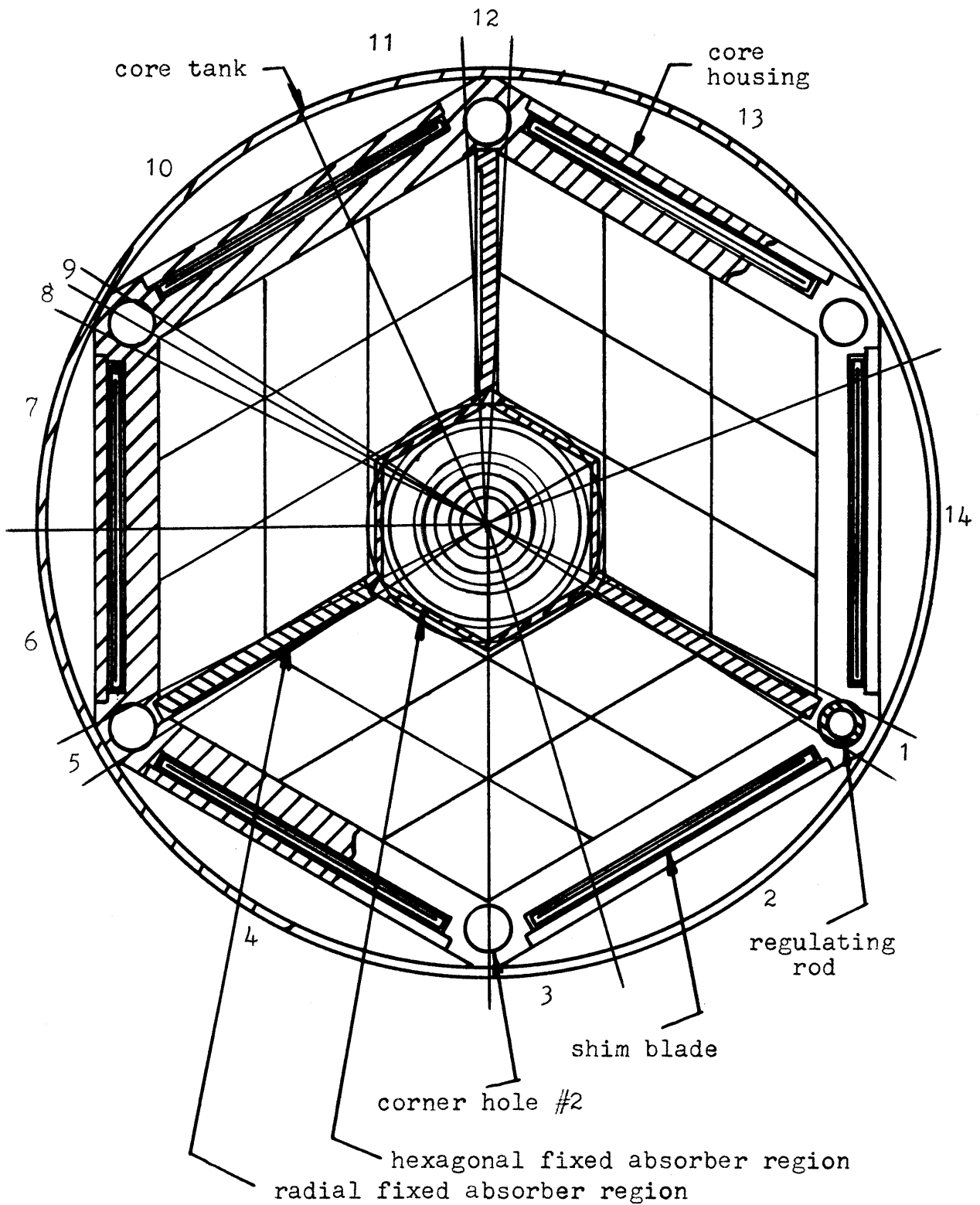

FIGURE 5-4. Horizontal section showing core model for double element irradiation facility.

case of steel sample ejection from the core and resulted in a reactivity increase of $1.56\% \Delta K_{\text{eff}}$. The final case determined the reactivity effect of replacing the molybdenum sample with a void. The result was a reactivity increase of $.25\% \Delta K_{\text{eff}}$. Since the sample contained 382 gm. of molybdenum metal, the estimated reactivity effect per gram of metal is $6.54 \times 10^{-4} \% \Delta K_{\text{eff}}$. The results of the first run are recapped in Table 5-2; prediction factors from the three dummy core have been used to estimate the technical specification limits shown.

The predicted safety and operating limits for this case are well below their maximum allowed values. It would therefore be possible to safely operate the core with this orientation. The maximum limits for this case occur in the outer ring of fuel, not in the area immediately adjacent to the experimental facility. With flooding of the large sample channel, however, an unacceptable power peak would occur in core position A-2, immediately adjacent to the flooded channel. To prevent this, a secured filler plug would be required for the large channel if a sample was not being irradiated.

For case 1, the thermal flux in the molybdenum sample ranged from a low of $1.9 \times 10^{13} \text{ n/cm}^2 \text{ sec}$ at the top, to a high of 5.7×10^{13} at the sample's bottom. The epithermal flux reached 6.2×10^{13} near the top, and dipped to 4.3×10^{13} at the lower tip. The fluxes in the steel are plotted in Figures 5-5 and 5-6. The first figure shows the fast (above 3 kev) and thermal fluxes through the sample's center

TABLE 5-2

RESULTS OF THREE GROUP DOUBLE ELEMENT FACILITY CALCULATION

<u>Case</u>	<u>Description</u>	<u>K_{eff}</u>	<u>Max. Safety Limit⁺</u>		<u>Max. Operating Limit⁺</u>					
			<u>value</u>	<u>position</u>	<u>value</u>	<u>position</u>	<u>height (inches)</u>	<u>F_R</u>	<u>F_A</u>	<u>Z</u>
1	dummy & double element facility- steel and moly samples in place	.9884	2.05	A-2, adjacent to facility	3.10	C-1, at edge of core	6	1.28	1.89	.48

⁺The d_{FP} values used are from the 3 dummy case as shown on Table 3-2. These technical specification limits have been estimated by the use of prediction factors obtained by comparing experimental three-dummy data with CITATION predicted data. For the C-ring, the factors listed in Table 3-3 were used; for the A-ring the prediction factors were obtained by comparing experimental data for the hottest plate (plate 1, A-1) to the hottest A-ring CITATION channel.

FIGURE 5-5. Fast (above 3kev) and thermal fluxes along centerline of steel sample.

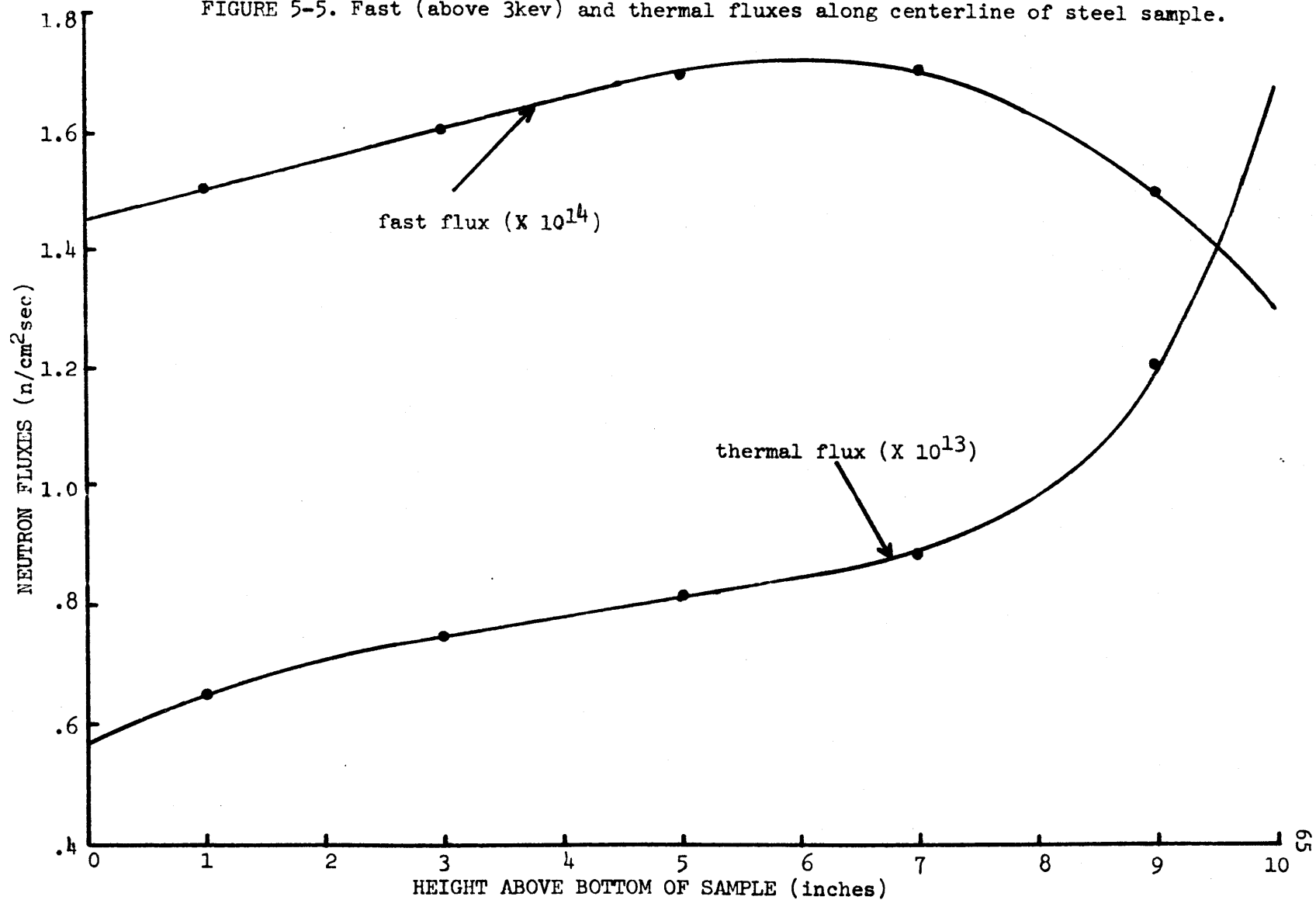
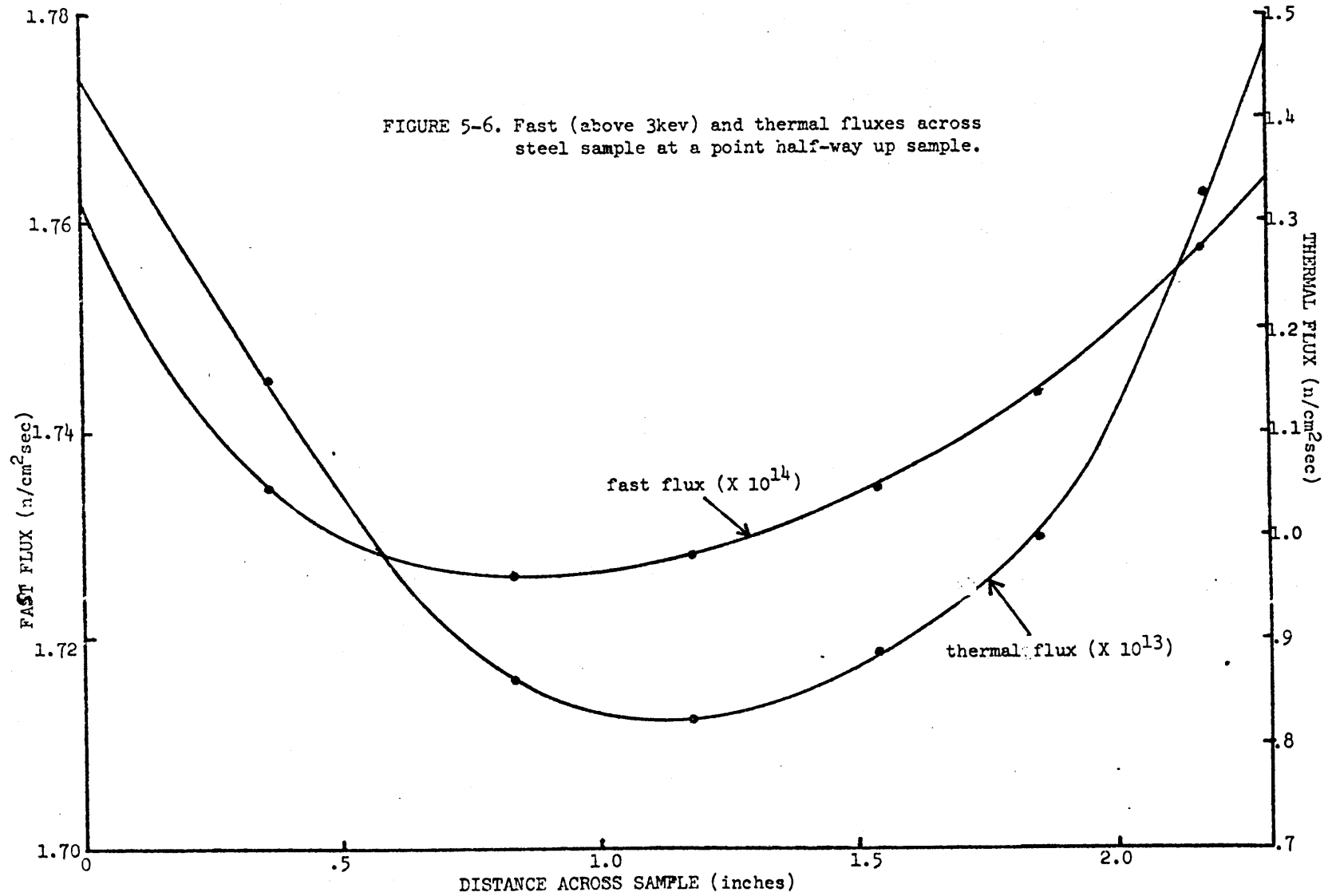

FIGURE 5-6. Fast (above 3kev) and thermal fluxes across steel sample at a point half-way up sample.



as a function of axial height in the core. The next figure is a plot of the same fluxes across the sample at a fixed axial position half-way up the sample. This curve shows that the fast flux near the sample's center is approximately 2.5% lower than that at the edge. The depression found in the thermal flux is much greater, about 45%.

Under the condition of case 3, the thermal flux reached a peak of 1.8×10^{14} n/cm²sec at the center of the large channel, 7 inches above the fuel bottom. As noted, however, the power peaking is unacceptable and this flux level is therefore unattainable with this facility.

The thermal flux seen along the core centerline at the height of the beam ports was found to be 8.7×10^{13} n/cm²sec. This value was essentially the same for all three cases. In comparison with other facilities, this flux level is about 6% lower than the predictions obtained for other core configurations employing hafnium fixed absorbers. However, it is higher than that found in cases where no fixed absorber is present.

CHAPTER 6
CENTRAL IRRADIATION FACILITY STUDIES

During the initial criticality testing of the MITR-II it was determined that the optimum core configuration included three non-fueled positions. By fueling the entire B and C-rings, the three A-ring positions would be freed for other purposes. A facility could be developed for this region which would allow much more space and flexibility than found in the previously studied sample assemblies. The size of such a facility is restricted, however, by a regulation which limits the cross-sectional area of any in-core facility to within 16 square inches for research reactors (Reference 17). Since the MITR-II is licensed by the Nuclear Regulatory Commission as a research reactor, the full 20.3 square inches of the A-ring can not be used. Probably the best way to restrict the facility size is to include a separate aluminum structure which would fit just inside of the core spider assembly. This would be supported by the lower grid plate and restrained by the top hold down plate. Such a structure would surround a cylindrical volume with a 16 square inch cross-sectional area.

This central region could be a useful place for the irradiation of large samples at a high flux. Another possibility is the development of a thermal "flux-trap". This could be accomplished by correctly orienting a moderating material in the central area. Fast neutrons entering from the surrounding fuel would be thermalized, producing a high thermal flux. The present chapter investigates some of the

potentials of this central region and proposes a "central irradiation facility" design based on the flux-trap concept. This design is capable of producing a high thermal flux while limiting power peaking to acceptable levels.

6.1 EFFECT OF VARIOUS MATERIALS IN THE CENTRAL FACILITY

CITATION calculations were first performed to investigate the effects of several different materials in the central facility. The materials used were fuel, water, and mixtures of aluminum and water. A neutron poison, in the form of an annular ring of boron-stainless-steel, was also included in certain cases to prevent excessive power peaking.

These cases were run using a three group energy structure, and a two-dimensional core model similar to that described in Section 5-1. Hafnium fixed absorbers were positioned at a height of 12 inches, and the boron-stainless-steel blades were at 8 inches. Five cases were considered; each is described as follows:

Case	Material in Central Facility
1	fuel
2	90% aluminum - 10% water mixture
3	100% water, with a ring of boron-stainless-steel poison at lower outside edge of facility, poison density is 12.5% of the shim blade density
4	100% water with a ring of boron-stainless-steel poison at lower outside edge of facility, poison density is 6.3% of the shim blade density
5	10% aluminum - 90% water mixture, with a ring of boron-stainless-steel poison at lower outside edge of facility, poison density is 6.3% of the shim blade density

Some of the results for these cases are listed in Table 6-1. The "CITATION-only" estimates of the safety and operating limits for each situation can be seen to be within acceptable boundaries. The operating limits for cases 4 and 5 are the only ones which come close to their maximum allowed value. This maximum was purposely approached in order to determine the largest thermal flux which could be obtained in the central facility, while still avoiding unacceptable power peaking. The highest predicted operating limit of 3.35 (case 4) is 10% below the maximum allowed value of 3.72. The 10% margin was allowed in order to account for the approximate nature of the CITATION predictions, especially when a two-dimensional core model is used.

The poison employed for cases 4, 5 and 6 was in the form of a 0.25 inch thick cylindrical ring of material equivalent to that which makes up the boron-stainless-steel shim blades, but of a reduced density. It was positioned just inside the fixed absorber spider assembly and reached up 10 inches from the fuel bottom. An equivalent poisoning strategy would be to use a higher concentration of boron in stainless-steel and a thinner poison region.

Table 6-2 lists the thermal flux levels located near the tips of the beam ports, and the value of the maximum thermal flux attained in each facility. These predictions are not as accurate as those which would be obtained from a three-dimensional calculation. However, they can be used to gain a rough idea of the expected fluxes. Beam port flux values for the fuel and the 90% aluminum - 10% water mixture

TABLE 6-1

Results of two-dimensional CITATION study of various materials in the central facility

Case	Material in Facility	K_{eff}	Max. Safety Limit*		Max. Operating Limit*					
			value	position	value	position	height above fuel bottom (inches)	F_R	F_A	Z
1	Fuel	1.0929	1.50	at core G_L	1.62	at core G_L	9	.98	1.52	.65
2	90% Al - 10% H ₂ O mixture	1.0286	1.65	at edge of core	2.44	at edge of core	5	1.08	2.02	.53
3	100% H ₂ O with B-SS poison (density = 12.5% blade density)	.9620	1.81	B-ring, near spider	2.98	B-ring, near spider	11	1.18	1.80	.84
4	100% H ₂ O with B-SS poison (density = 6.3% blade density)	.9782	2.06	B-ring, near spider	3.35	B-ring, near spider	11	1.35	1.65	.87
5	10% Al - 90% H ₂ O mixture with B-SS poison (density = 6.3% blade density)	.9829 ⁺	2.04	B-ring, near spider	3.29	B-ring, near spider	11	1.34	1.64	.87

*These are "CITATION-only" values computed with a blade height of 8 inches; fixed hafnium absorbers were at 12 inches. All values of d_{FP} were taken to be .94, the lowest measured value for the 3 dummy core.

⁺A different mesh spacing arrangement was used for this case, it is therefore not appropriate to compare this value with the previous K_{eff} values.

TABLE 6-2

RESULTS OF CITATION FLUX CALCULATIONS FOR
 VARIOUS MATERIALS IN THE CENTRAL FACILITY

<u>Case</u>	<u>Material in Facility</u>	<u>Beam Port Thermal Flux(n/cm²sec)</u>	<u>Max. Thermal Flux in Facility(n/cm²sec)</u>
1	Fuel	7.3×10^{13}	3.3×10^{13}
2	90% Al - 10% H ₂ O mixture	7.9×10^{13}	5.9×10^{13}
3	100% H ₂ O with B-SS poison ² (density = 12.5% blade density)	8.4×10^{13}	2.6×10^{14}
4	100% H ₂ O with B-SS poison ² (density = 6.3% blade density)	8.8×10^{13}	2.7×10^{14}
5	10% Al - 90% H ₂ O with B-SS poison (density = 6.3% blade density)	8.8×10^{13}	2.5×10^{14}

are the lowest seen in any of the computer calculations performed for this work. However, the results for cases 4 and 5 are among the highest found for any irradiation facility; only the flooded single element sample holder with fixed absorbers produced a higher beam port flux.

A maximum thermal flux of 2.7×10^{14} n/cm² sec was developed in case 4. This configuration positioned 100% water in the facility and boron-stainless-steel (of lower density) at the edge of the facility. Increasing the poison density was found to decrease the magnitude of the thermal flux (case 3); reducing the water density also had the same effect (case 5).

Plots of the fluxes in the central facility for cases 1, 2 and 4 are given in the next several figures. Figures 6-1 and 6-2 show the thermal and epithermal fluxes axially along the centerline of the core. The water-filled region produced the highest thermal flux reaching its maximum of 2.7×10^{14} n/cm² sec at a height of about 7 inches up the facility. However, it also produced the lowest epithermal flux levels of the three cases considered. With fuel in the central facility, the epithermal flux was optimized, but the thermal flux was the lowest over the active core length. The fluxes obtained in the active core for the 90% aluminum - 10% water mixture were intermediate between the other two cases.

Figure 6-3 plots the thermal flux radially outward from the centerline at a height of 7 inches above the fuel bottom. For the water case, the thermal flux can be seen to drop sharply at the region containing the boron-stainless-steel poison.

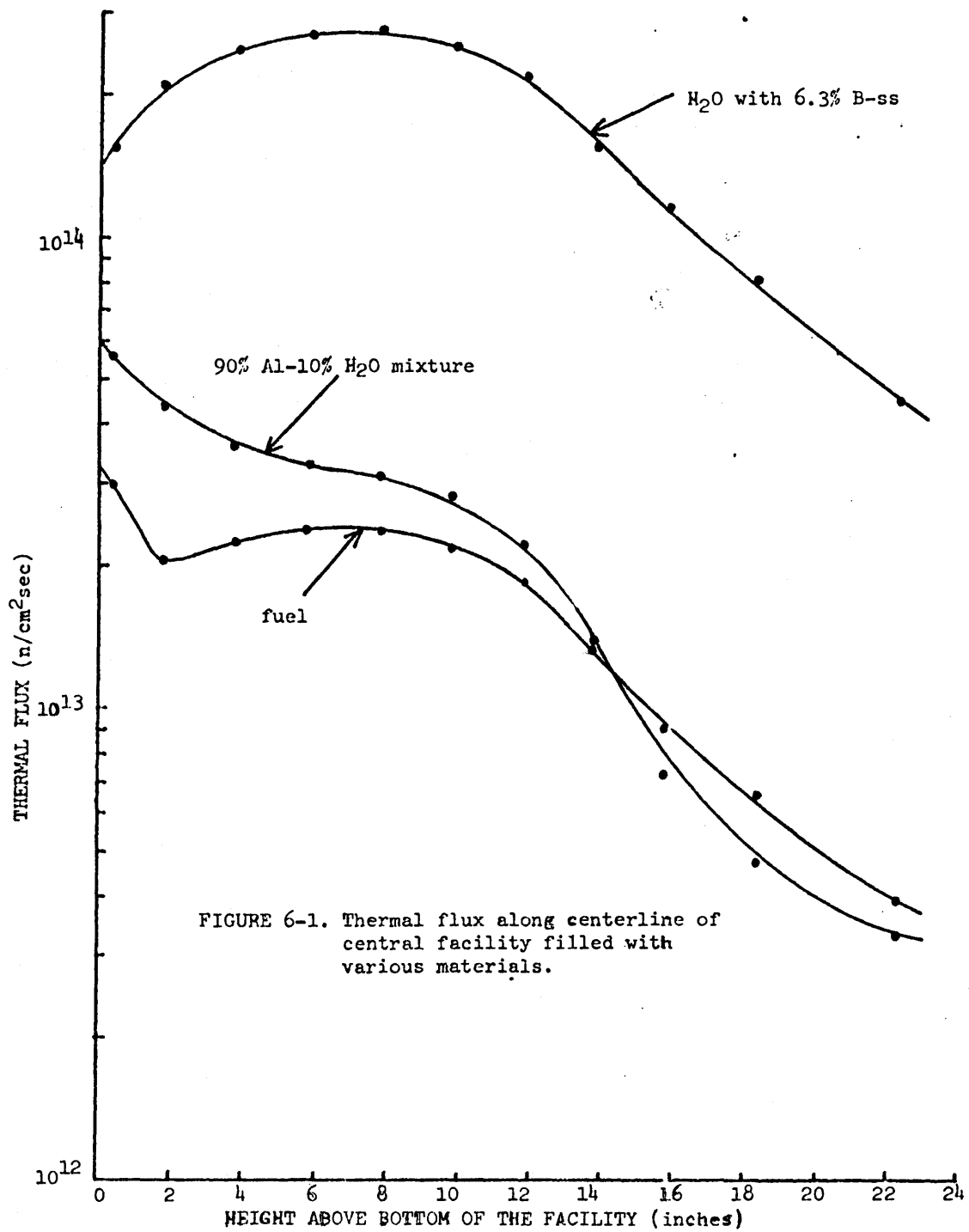

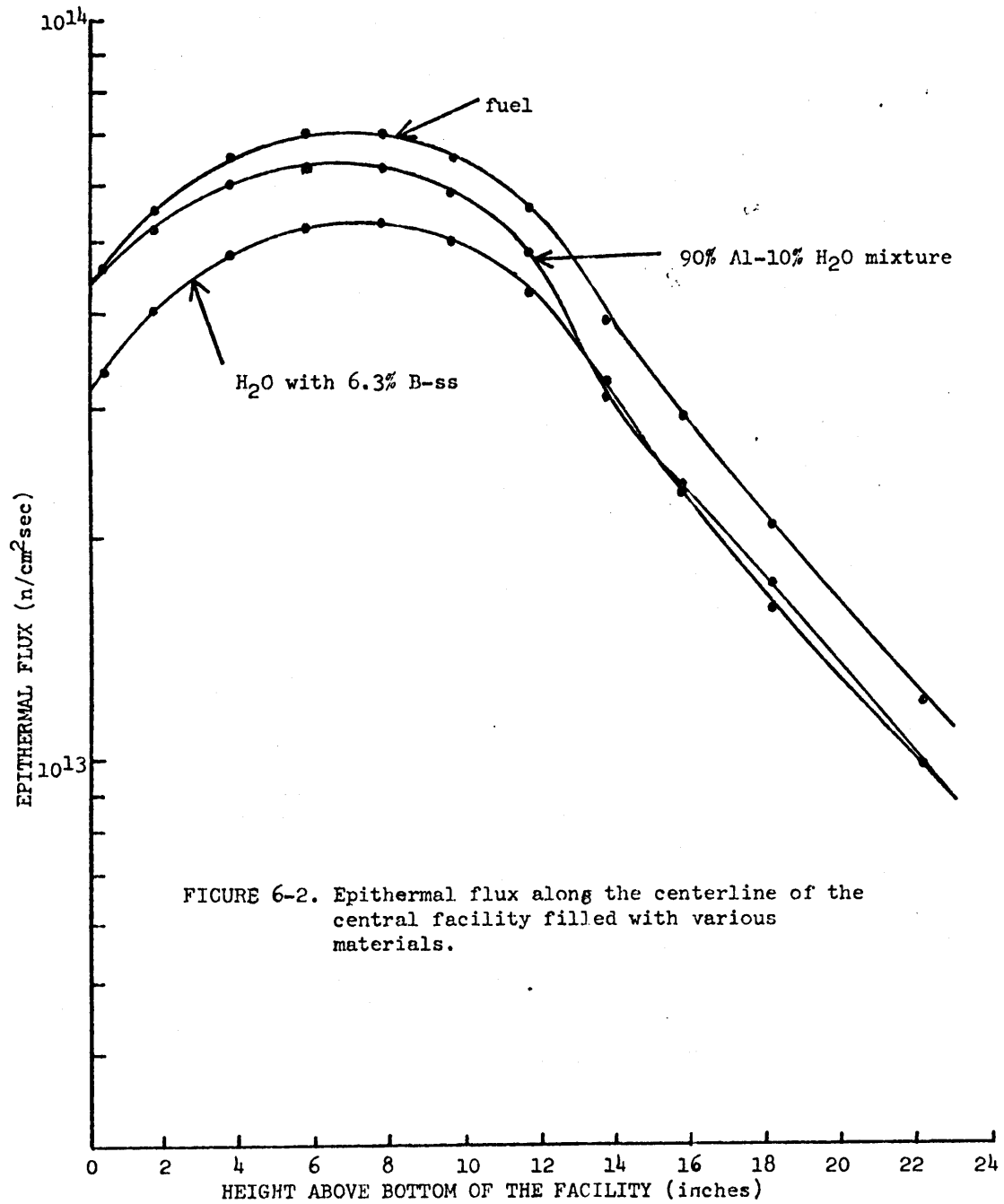

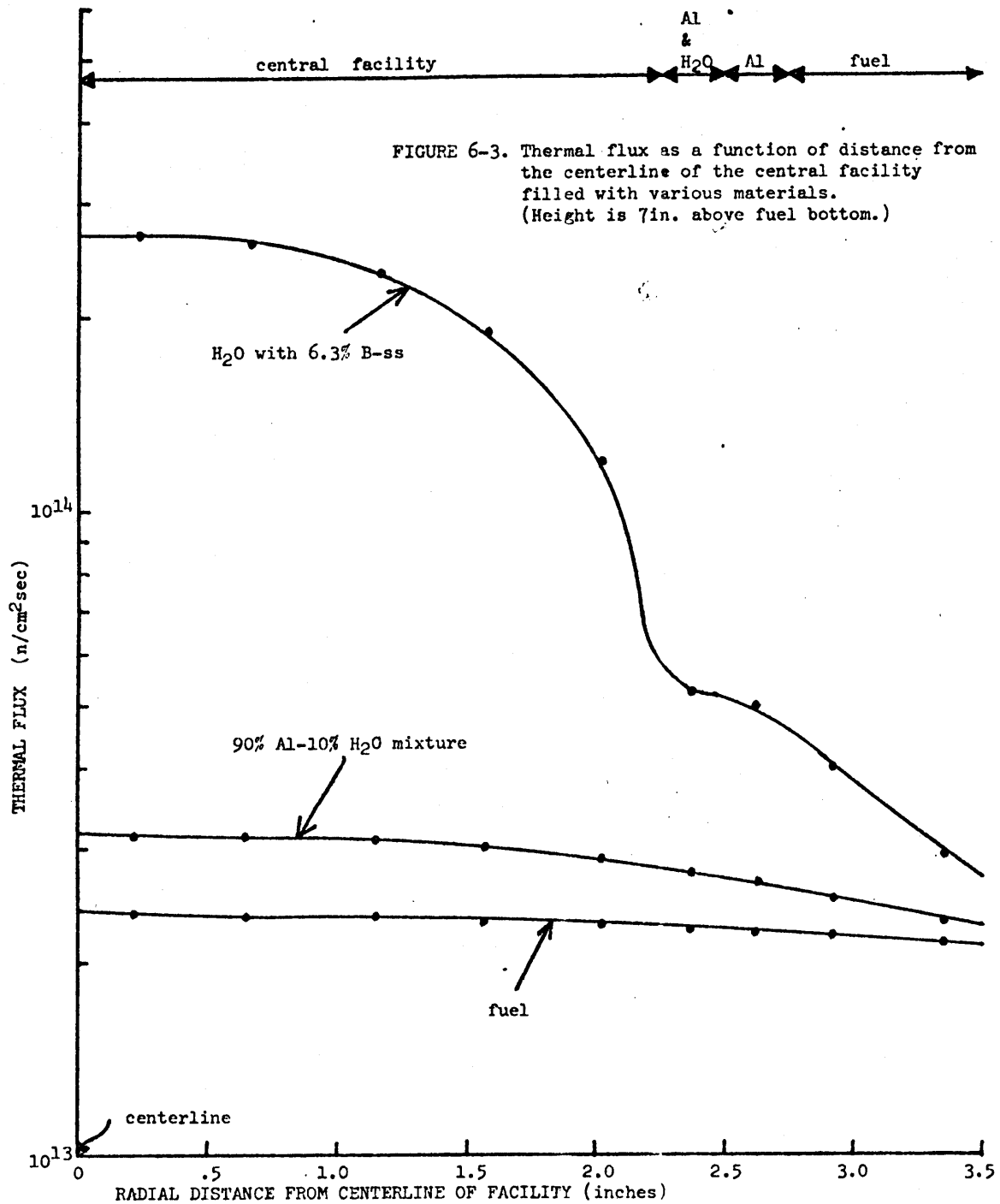

6.2 PROPOSED CENTRAL IRRADIATION FACILITY DESIGN

In developing an effective central irradiation facility design, the thermal flux levels should be optimized while holding the core's maximum safety and operating limits to acceptable values. As seen previously, power peaking can be reduced by excluding water, by introducing a poison region, or both. Each of these options, however, can degrade the thermal flux levels.

The design proposed in this section employs both means of reducing power peaking. First, it places aluminum near the bottom and outside edges of the facility to exclude water. Second, it includes a ring of molybdenum oxide samples in the lower outside area of the facility to act as a poison. Since resonance capture accounts for a large fraction of the neutron absorption in molybdenum, the positioning of these samples in this high epithermal flux region should be suitable. Periodic removal and replacement of the molybdenum samples will allow the recovery of the valuable technetium - 99m isotope produced by activation of molybdenum - 98.

A vertical cross section of the proposed facility is shown in Figure 6-4. The central sample tube extends down to a point that is 4 inches above the fuel bottom. It is immediately surrounded by a wide water region, which will produce a high thermal flux in the tube. Regions of aluminum and molybdenum oxide surround the water volume. In the actual core setup, the molybdenum could be in the form of samples with a rectangular cross section, set side by side as shown in Figure 6-5. Another possibility is the use of small cylindrical samples as shown in Figure 6-6.

FIGURE 6-4. Vertical cross section of proposed central irradiation facility. (approximately one-half scale)

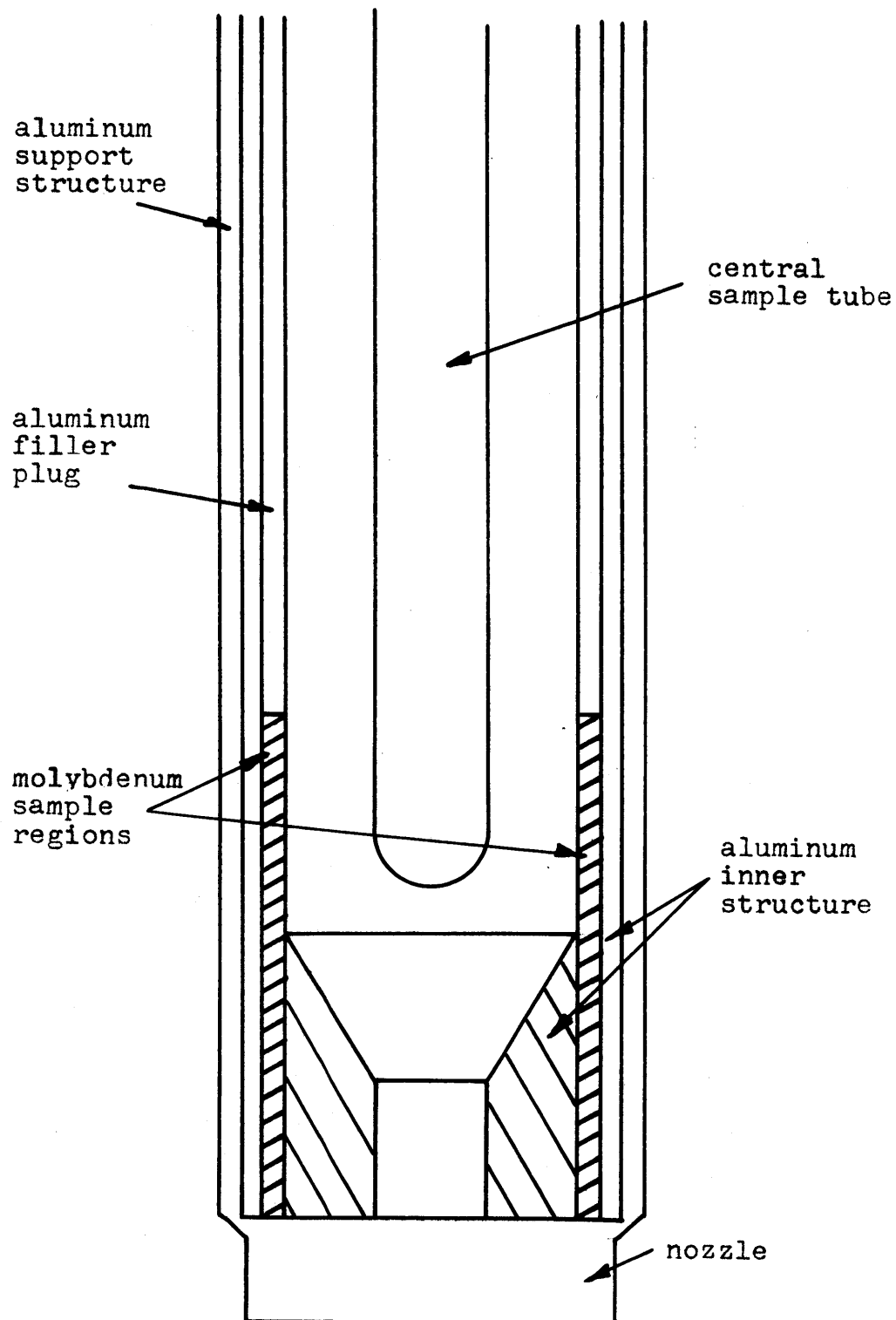

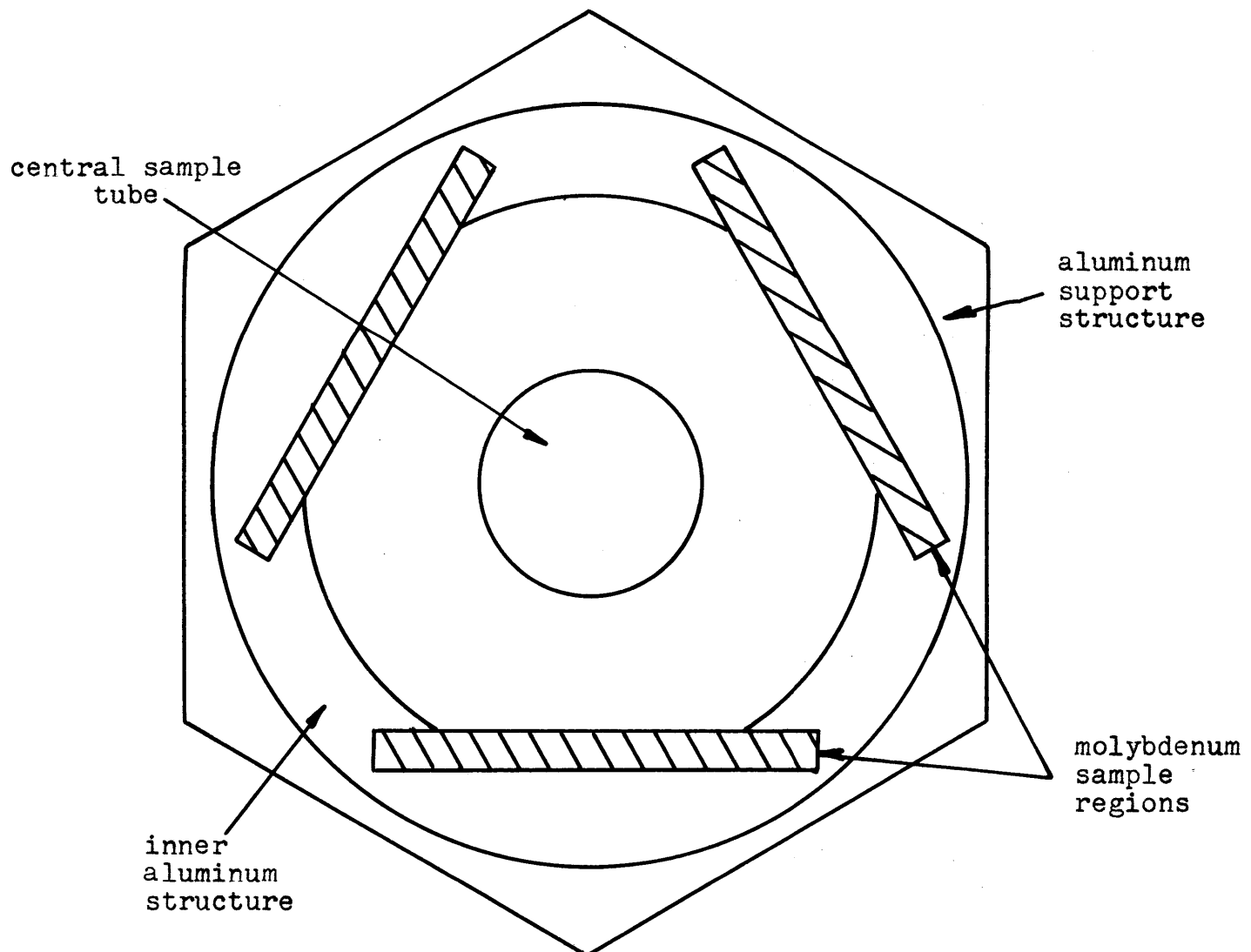

FIGURE 6-5. Horizontal cross section of proposed central irradiation facility with rectangular molybdenum sample regions.

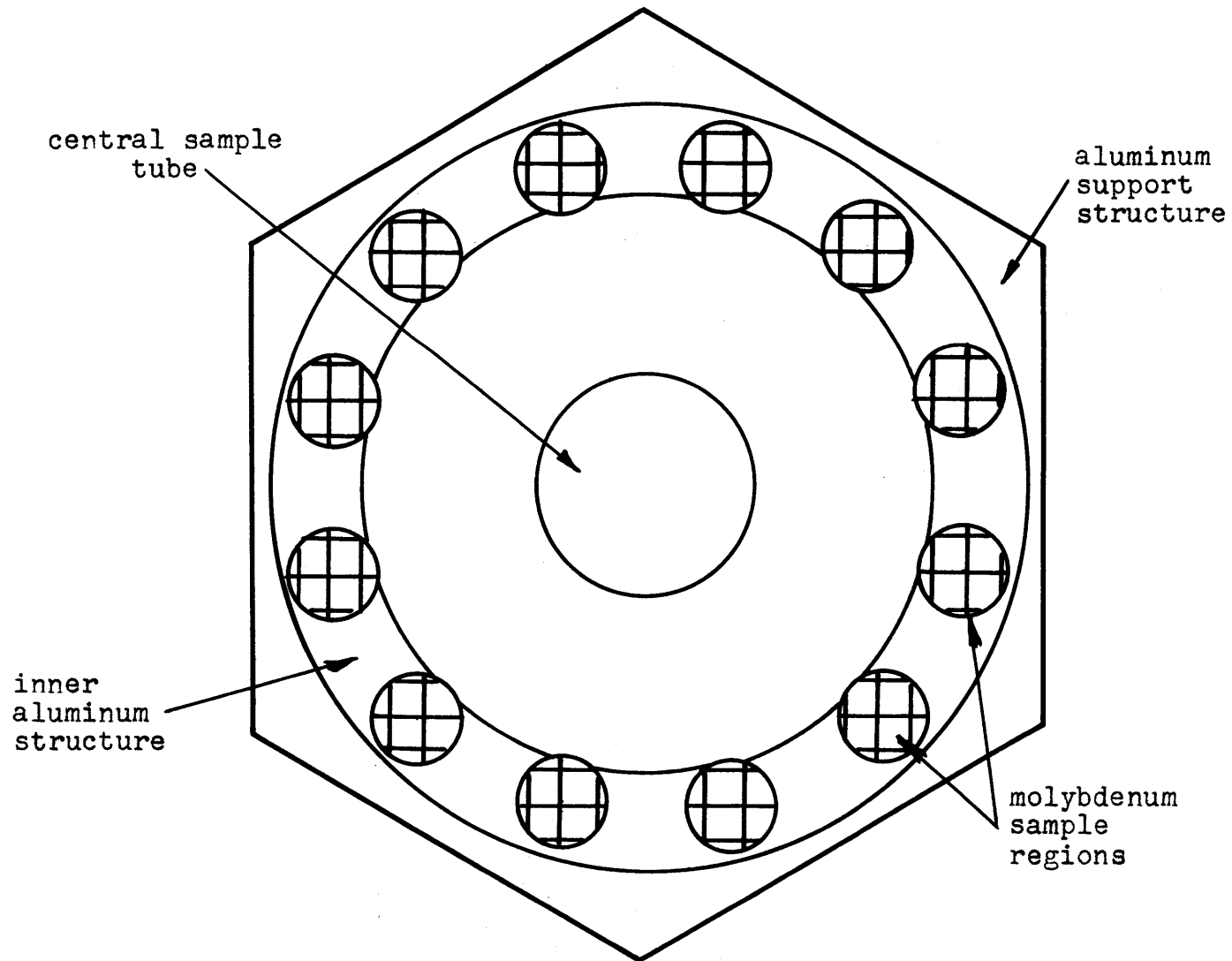

FIGURE 6-6. Horizontal cross section of proposed central irradiation facility with cylindrical molybdenum sample regions.

The two-dimensional core model and zone compositions used to mock up this facility are depicted in Figure 6-7. Table 6-3 lists the materials associated with each zone composition. The hafnium fixed absorbers and boron-stainless-steel shim blades were positioned at 12 inches and 8 inches, respectively, and aluminum was placed in the sample tube for this calculation.

Estimates of the technical specification limits provided by this computer run are well below the maximum allowed values. The largest "CITATION-only" safety limit of 2.00 occurs in the B-ring of elements, adjacent to the central spider. The maximum operating limit of 3.09 also occurs in the B-ring, at a height of 7 inches above the fuel bottom.

The thermal flux predicted to occur near the tips of the beam ports is 8.65×10^{13} n/cm²sec. This is higher than the estimate for the voided molybdenum sample holder in a core without fixed absorbers. However, it is less than or equivalent to the values obtained for the other facilities which employ fixed absorbers.

The thermal flux in this proposed central irradiation facility reaches a maximum value of 1.97×10^{14} n/cm² sec at a point just below the sample tube's lower tip. The flux levels remain high in the lower half of the aluminum sample and in the water surrounding the sample. This can be noted in the thermal flux map of Figure 6-8. The epithermal flux is found to be fairly constant throughout the lower section of the facility, always close to a value of 6.0×10^{13} n/cm²sec. The fast (above 3 KEV) flux dips significantly in the central facility, as would be expected with a "flux-trap" design. The lower half of the

FIGURE 6-7. Two-dimensional core model used for proposed central facility calculations.
(not to scale)

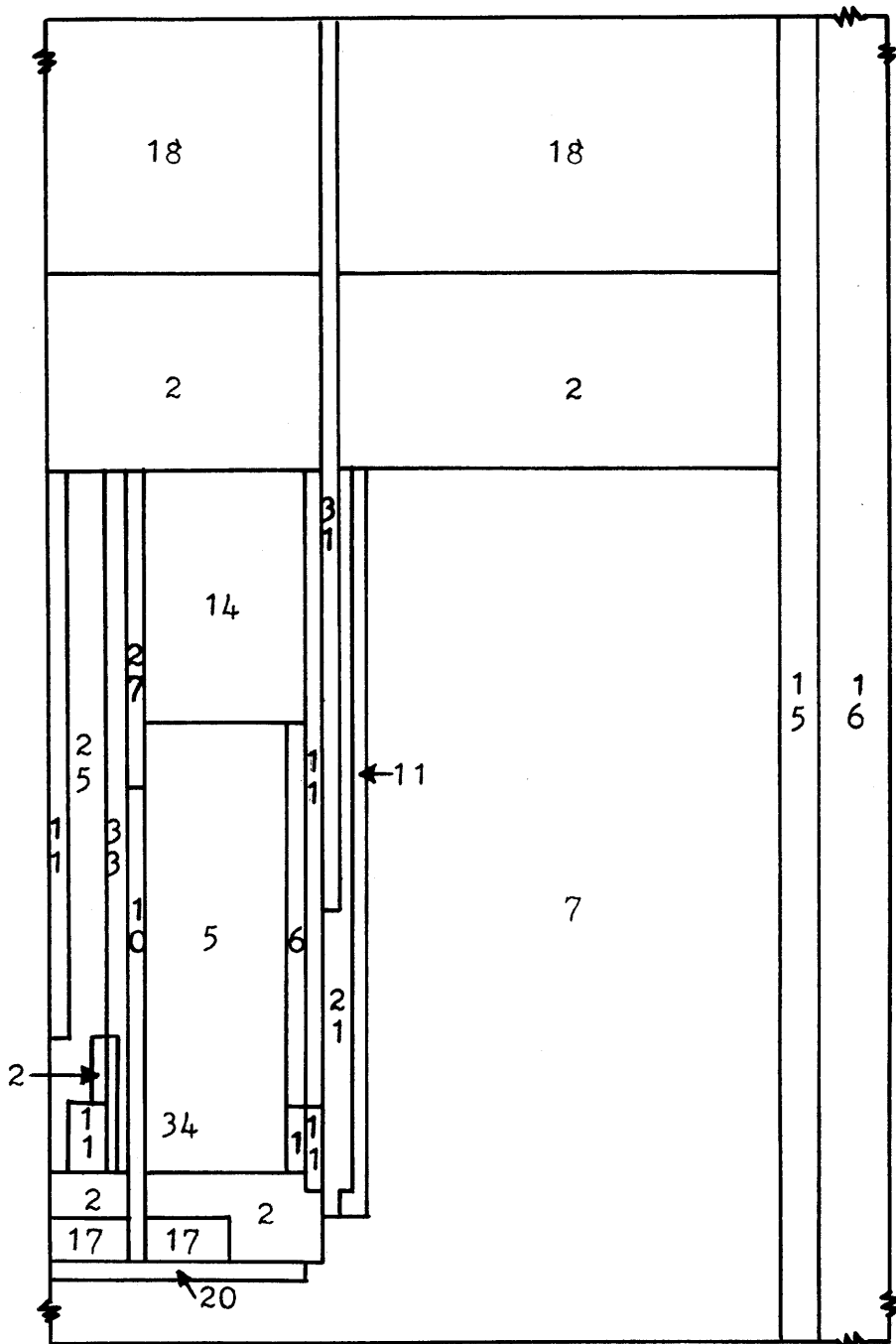

TABLE 6-3

ZONE COMPOSITIONS FOR 3 GROUP FLUX-TRAP

FACILITY CALCULATIONS

(Omitted numbers were not used)

<u>Zone</u>	<u>Nuclide Number</u>	<u>Nuclide Name</u>	<u>Number Density (atoms/cm-b)</u>
1	1	U-235	4.390×10^{-4}
	2	U-238	3.359×10^{-5}
	3	H ₂ O	1.545×10^{-2}
	4	Al	3.183×10^{-2}
2	32	H ₂ O	1.655×10^{-2}
	33	Al	3.012×10^{-2}
5	15	U-235	4.390×10^{-4}
	16	U-238	3.359×10^{-5}
	14	H ₂ O	1.545×10^{-2}
	13	Al	3.183×10^{-2}
6	17	U-235	4.390×10^{-4}
	18	U-238	3.359×10^{-5}
	19	H ₂ O	1.545×10^{-2}
	20	Al	3.183×10^{-2}
7	21	D ₂ O	3.275×10^{-2}
	22	Al	1.621×10^{-4}
	47	H ₂ O	1.646×10^{-4}
10	38	Al	6.023×10^{-2}
11	53	Al	6.023×10^{-2}
14	28	U-235	4.390×10^{-4}
	29	U-238	3.359×10^{-5}
	31	H ₂ O	1.545×10^{-2}
	30	Al	3.183×10^{-2}

<u>Zone</u>	<u>Nuclide Number</u>	<u>Nuclide Name</u>	<u>Number Density (atoms/cm-b)</u>
15	39	H ₂ O	1.655 x 10 ⁻²
	40	Al	3.012 x 10 ⁻²
16	41	C	8.334 x 10 ⁻²
17	42	D ₂ O	1.654 x 10 ⁻²
	43	Al	3.120 x 10 ⁻²
18	44	H ₂ O	3.340 x 10 ⁻²
20	47	H ₂ O	3.340 x 10 ⁻²
21	48	H ₂ O	3.340 x 10 ⁻²
25	32	H ₂ O	3.340 x 10 ⁻²
27	35	Al	4.455 x 10 ⁻²
	60	Hf	3.188 x 10 ⁻²
31	62	B-SS	9.026 x 10 ⁻⁴
33	32	H ₂ O	1.336 x 10 ⁻³
	53	Al	5.782 x 10 ⁻²
34	32	H ₂ O	1.670 x 10 ⁻³
	59	Mo	1.864 x 10 ⁻²

FIGURE 6-8. Vertical section of proposed central facility showing lines of constant thermal flux. (values in $10^{-14}n/cm^2sec$)

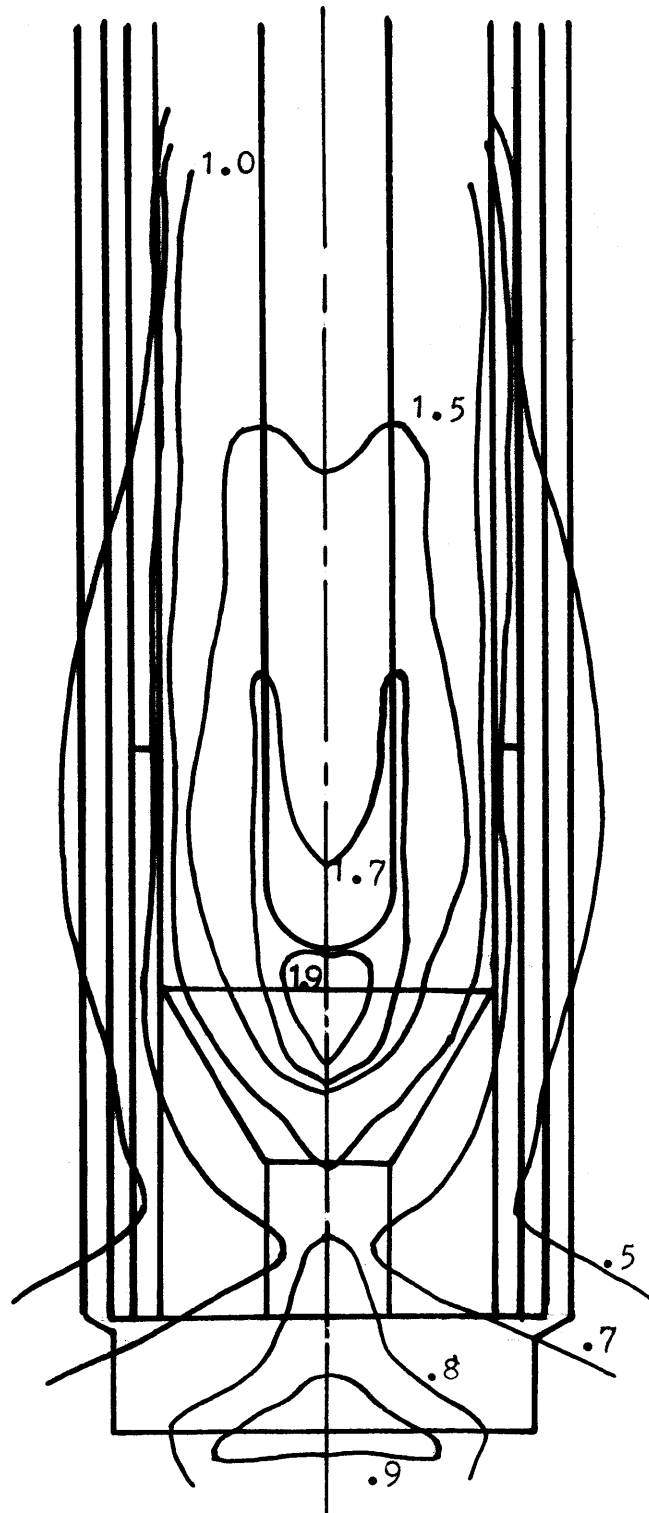

sample sees a fast flux of approximately 1.1×10^{14} n/cm² sec.

Another CITATION calculation was performed to investigate the effects of flooding the central sample tube. The K_{eff} for this flooded case is 1.0117; the voided value (from the previous calculation) is 1.0136. This results in a reactivity change of $-0.19\% \Delta K_{\text{eff}}$ due to flooding. The thermal flux in the flooded sample tube reaches a peak of 2.5×10^{14} n/cm² sec at a point about 2 inches above the bottom of the tube. The beam port thermal flux levels remain almost unchanged.

The technical specification limits for the flooded case occur at the same locations, but increase in magnitude. The maximum "CITATION-only" value of the safety limit increases by 2% to a value of 2.04, while the operating limit increases 4% to a value of 3.21.

Suppression of the power peaking in this design is due largely to the exclusion of water by the molybdenum samples and the aluminum structural material. The absorption effect of the molybdenum plays only a minor role in reducing the safety and operating limits. Therefore, it would most likely be possible to use the molybdenum sample positions for any materials which must be irradiated. This would provide greater flexibility in the management of in-core irradiation samples than would be available with a single sample tube alone.

CHAPTER 7

CONCLUSIONS AND RECOMMENDATIONS FOR FUTURE WORK

This work is an investigation of the neutronic effects of one, two, and three element sample assemblies for the MITR-II. Before much of this work could be carried out, various three and fifteen group cross section sets had to be generated and prepared for input into the CITATION computer code. The procedures involved in this work are described in Chapter 2. In addition, an updated listing of the three group CITATION cross section library is provided at the beginning of the sample computer run of Appendix D.

The safety and operating limits have been estimated for various core configurations of the assemblies. Prediction factors, as described in Section 3.3, have been used to compensate for the fact that CITATION generally underpredicts these limits. The results of the calculations have shown that in the five dummy core, the molybdenum sample holder can be safely operated in either a voided or flooded condition with a shim blade height of up to 13.6 inches at a core power of 2.5 MW. A three dummy case, which includes the flooded molybdenum sample holder, hafnium fixed absorbers at 12 inches, and boron-stainless-steel shim blades at 8 inches, was also studied. This configuration was found to result in safety and operating limits which are within acceptable margins. The technical specification limits for the

double element facility are far below the maximum allowed values, but flooding of the large sample channel is not acceptable. (As more information becomes available about the hafnium poisoned core, the validity of the underprediction factors used in these estimates should be checked.)

The "CITATION-only" limits for the central irradiation facility proposed in Chapter 6 are well within their allowed ranges. However, these values were obtained from a two-dimensional calculation which does not provide adequate detail for accurate limit evaluation. A three-dimensional computer analysis of this facility should be undertaken for more precise predictions. The B-ring underprediction factors should also be evaluated and applied for this core configuration.

When calculating the technical specification limits, the value of the plenum flow disparity (ratio of the coolant flow through the element in question to the average element's flow) is of considerable importance. Measured values from the three and five dummy cores were used in analysis of the single and double element assemblies. For the work in Chapter 6, however, a conservative plenum flow disparity of 0.94 was assumed for each channel. This number is well below the B-ring values measured for the three and five dummy cores. In addition, it is likely that introduction of the proposed flux-trap would divert additional flow to the B-ring, producing larger d_{Fp} values than those measured. This would result in much lower "CITATION-only" safety and operating limits than shown in Chapter 6.

Maintenance of high thermal flux levels in the beam ports is an important consideration when developing a sample assembly design. The

largest calculated beam port flux value was $9.3 \times 10^{13} \text{ n/cm}^2 \text{ sec}$ (excluding the unrealistic case in Appendix B which used the old cadmium cross section set). This value of $9.3 \times 10^{13} \text{ n/cm}^2 \text{ sec}$ was reached in the hafnium poisoned core with the flooded molybdenum sample tube (Chapter 4), and in the three-dummy fixed-absorber cores described in Appendix B.

The proposed three-element flux-trap and double element sample facility both produce beam port fluxes of $8.7 \times 10^{13} \text{ n/cm}^2 \text{ sec}$. $8.5 \times 10^{13} \text{ n/cm}^2 \text{ sec}$ was the lowest value generated in any of the functional sample assembly configurations. This occurred for the voided molybdenum sample assembly in a core without fixed absorbers. Table 7-1 contains the beam port flux values obtained for various core configurations; the maximum fast and thermal flux values seen in each setup are also listed.

The maximum thermal flux predicted to occur for any core configuration was $2.7 \times 10^{14} \text{ n/cm}^2 \text{ sec}$. This value was attained with a completely flooded central core region (16 square inches in horizontal cross section) and boron-stainless-steel poison at the core bottom. Of the irradiation facilities studied, the proposed flux-trap produced the greatest thermal flux, reaching $2.0 \times 10^{14} \text{ n/cm}^2 \text{ sec}$. With flooding of the central sample tube, this value increased to $2.5 \times 10^{14} \text{ n/cm}^2 \text{ sec}$. The remainder of the experimental facilities developed much lower thermal flux levels. For example, the maximum achieved with the flooded molybdenum sample holder with hafnium fixed absorbers was $8.5 \times 10^{13} \text{ n/cm}^2 \text{ sec}$, and the double element facility reached a value of only $5.7 \times 10^{13} \text{ n/cm}^2 \text{ sec}$.

TABLE 7-1

RESULTS OF CITATION FLUX CALCULATIONS FOR VARIOUS CORE CONFIGURATIONS

<u>Core Configuration</u>	<u>Thermal Beam Port Flux (n/cm²sec)</u>	<u>Max. Thermal Flux in the Facility</u>	<u>Max. Fast (>3 KEV) Flux in the Facility</u>
4 dummy core & voided moly sample holder Cd blades at 8"	8.5×10^{13}	5.4×10^{13}	1.6×10^{14}
2 dummy core & flooded moly sample holder, Hf fixed at 12", B-SS blades at 8"	9.3×10^{13}	8.5×10^{13}	1.7×10^{14}
Double element facility with steel & moly in place, Hf fixed at 12", B-SS at 8"	8.7×10^{13}	5.7×10^{13}	1.7×10^{14}
Fully flooded central facility with B-SS poison (6.3% of blade density)	8.8×10^{13}	2.7×10^{14}	$1.2 \times 10^{14+}$
Proposed flux trap			
a) voided central tube	8.7×10^{13}	2.0×10^{14}	$1.2 \times 10^{14*}$
b) flooded central tube	8.7×10^{13}	2.5×10^{14}	$1.1 \times 10^{14*}$

⁺ Occurs at edge of facility

*Maximum values in the central sample tube

CITATION showed that the optimum assemblies for producing a fast flux were the double element facility and the molybdenum sample holder (with fixed absorbers in place). The maximum values obtained for the flux component above 3 kev were close to 1.7×10^{14} n/cm²sec for each facility. (The flux above .9 MEV was found to peak at 5.2×10^{13} n/cm²sec in the steel sample of the double element facility.) The flux-trap design of Chapter 6 produced a fast flux of only 1.2×10^{14} in its central sample tube.

It should be noted that the central region of the core is potentially useful for many other types of facilities besides the proposed flux-trap design. A central facility might be designed to place a region of fuel material immediately adjacent to a sample tube. This would allow an ideal place for the irradiation of samples in a fast flux. Another possibility is a facility which would provide space for the irradiation of very large samples. Larger samples could be allowed for in the design of the flux-trap facility, simply by the use of a larger sample tube. Excluding water in this manner would reduce the thermal flux levels. However, operation of the tube in a flooded condition would help to alleviate this problem.

Flooding some of the sample tubes in the proposed flux-trap might be a useful way to increase the thermal flux attained. For example, if specimens were placed in the molybdenum sample regions, the central sample tube might be flooded. The calculations performed in Chapter 6 determined that this procedure would increase the thermal flux levels in the specimens by up to 5%, and by slightly higher percentages in the aluminum filler region above the specimens. Conversely, it

may be possible to flood some of the molybdenum sample regions in order to maximize the thermal flux in the central sample tube and remaining molybdenum regions. Further calculations would be necessary to assure that the safety and operating limits would be acceptable for these conditions.

It has been seen that a large part of the analysis of potential core configurations and irradiation facilities deals with predicting the technical specification limits. The present computer models make this work difficult by underpredicting these limits in most cases. A more desirable prediction scheme has been suggested by Allen (Reference 14). He proposes that a full core analysis first be performed in order to find the relative power produced in each core position. This would point out several potentially troublesome elements in which the worst peaking might occur. A more detailed calculation would then be performed for each of these elements. Only the element itself would be considered in this computer model, and artificial boundary conditions would be employed to simulate the environment surrounding a particular element.

If it is known with some certainty where the power peak will occur, an alternative procedure may be suitable. This would be to increase the number of mesh lines, but only in the region of the expected peak. A more detailed power density map would be generated in this way, and the accuracy of the limit predictions would improve. This scheme would be useful for investigating effects such as peaking adjacent to a flooded sample holder, or the peaking for a well-understood core configuration.

Another consideration in determining the future use of a flux trap facility is that of the reactivity worth in the core. It was found during the startup testing of the MITR-II that a core configuration employing three solid aluminum dummies would be the most useful at that time. However, three-dimensional CITATION runs have shown that switching from this original three dummy core (dummies in A-1, B-2, and B-8 with cadmium absorbers) to one with the same absorbers but a completely flooded central facility and with fuel in each B and C-ring position, would result in a reactivity decrease of approximately $1.35\% \Delta K_{\text{eff}}$. (Since the proposed flux trap is not completely water filled, the reactivity drop would not be this great, but a decrease would still occur). The control blades would have to be raised to compensate for this effect, causing the thermal flux levels in the beam ports to decrease. In addition, fuel burnup and fission product poisoning will decrease the reactivity worth of the core even further. It has been measured that these effects decrease K_{eff} by about .08% for an average week of scheduled operation at 2.0 MW to 2.5 MW. Therefore, it may eventually be desirable to increase the fuel loading over the three-dummy core loading in order to allow operations at lower shim blade heights. This could not be accomplished with the flux-trap facility and fixed absorbers both in place.

REFERENCES

1. Fowler, T. B., Vondy, D. R., and Cunningham, G. W., "Nuclear Reactor Core Analysis Code: CITATION", ORNL-TM-2496, (Revision 2, 1971).
2. Kadak, A. C., "Fuel Management of the Redesigned MIT Research Reactor", Ph.D. Thesis, MIT Department of Nuclear Engineering, (1972).
3. Addae, A. K., "The Reactor Physics of the Massachusetts Institute of Technology Reactor Redesign", Ph.D. Thesis, MIT Department of Nuclear Engineering, (1970), MITNE-118.
4. Hansen, G. E. and Roach, N. H., "Six and Sixteen Group Cross Section for Fast and Intermediate Critical Assemblies", LAMS-2543.
5. Fowler, T. B., et al, "EXTERMINATOR-II: A Fortran IV Code for Solving Multigroup Diffusion Equations in Two Dimensions", ORNL-4078 (1967).
6. Honeck, H. C., "THERMOS: A Thermalization Transport Theory Code for Reactor Lattice Calculations", BNL-5826, (1961).
7. Henry, A. F., "A Theoretical Method for Determining the Worth of Control Rods", WAPD-218, (1959).
8. Case, K. M., et al, "Introduction to the Theory of Neutron Diffusion (Volume I)", "Los Alamos Scientific Laboratory, (1953).
9. Emrich, W. J., "Reactivity Studies of the MITR-II", S. M. Thesis, MIT Department of Nuclear Engineering, (1974).
10. Hughes, D. J. and Harvey, J. A., "Neutron Cross Sections", BNL-325, (1955).
11. Stein, S., "Resonance Capture in Heterogeneous Systems", WAPD-139, (1955).
12. MITR Staff, "Safety Analysis Report for the MIT Research Reactor (MITR-II)", MITNE-115, (1970).
13. MITR Staff, "Technical Specifications for the MIT Research Reactor (MITR-II)", MITNE-122, (1973).
14. Allen, G. C., "The Reactor Engineering of the MITR-II Construction and Startup", Ph.D. Thesis, MIT Department of Nuclear Engineering, (1976), MITNE-186.

15. Soth, L. G., "An In-Core Irradiation Facility for the MIT Research Reactor Redesign", S. M. Thesis, MIT Department of Nuclear Engineering, (1972).
16. Yeung, M. K., "Reactivity Studies of the MITR-II for Initial Loading", 22.90 Special Report, MIT Department of Nuclear Engineering, (1975).
17. Code of Federal REgulations, Title 10, Chapter 1, Part 50, United States Nuclear Regulatory Commission, (1975).
18. Hove, C. M., "Extra Power Peaking in MITR-II Due to Manufacturing Tolerances in the Length of the Fuel Plates", 22.90 Special Report, MIT Department of Nuclear Engineering, (1973).

APPENDIX A

CONTROL BLADE HOMOGENIZATION AND MESH CORRECTION

This appendix describes a short computer program which provides two corrections to the equivalent diffusion theory parameters ($\bar{\Sigma}_a$ and \bar{D}) which are used in modelling a control blade region in a finite difference code. The first correction considers homogenization of the control blade (if it consists of multi-layered materials) by equating the fluxes (and currents) at each internal material interface. The second correction compensates for the effect which the mesh spacing of the control region (in the diffusion theory code) has on the blade's absorption. The mesh correction scheme employed here is applicable if the parameters are going to be used in a code which uses the same finite-difference approximation as CITATION.

These correction procedures were generated by Emrich (Reference 9), as based on work by Henry (Reference 7). The code presented here is a modification of a program originally written by Emrich which performs the same function.

An infinite slab approximation is assumed for the control blade in this work, therefore only a one-dimensional view is considered.

Input Variables

The variables which must be entered into the code are as follows:

<u>Variable</u>	<u>Variable name in code</u>	<u>Comments</u>
(1) number of blade regions	N	This is equal to the number of material regions which make up the blade. For example, a blade consisting of material A, clad on each side with material B, would have a value of 3.
(2) region widths	Z	These variables designate the thickness of each blade region; one is required for each region. (Units are cm)
(3) number of regions in diffusion theory blade mockup	M	This equals the number of mesh regions which will model the blade when the diffusion theory parameters are used in a code such as CITATION. In generating values to be used in the present CITATION models of the MITR-II, this number will equal 1.
(4) equivalent macroscopic absorption cross section (Σ_a)	SA2	One of these variables must be entered for each material region, starting at either side of the blade. If a material is heavily absorbing, blackness theory (see Section 2.2.2) must be used to develop the SA2 value. (Units are cm^{-1})
(5) equivalent diffusion coefficient	D2	One of these variables must be entered for each material region. If a material is heavily absorbing, blackness theory (see Section 2.2.2) must be used to develop the D2 value. (Units are cm)
(6) number of cases	NCT	This equals the number of different cases to be considered. If any of the variable numbers 2, 4, or 5 are changed, a new case must be input. If the variable numbers 1 or 3 are changed, a whole new run must be accomplished with the present logic setup.

Input Order

Variables are input on cards in the order outlined below. The format for each card is also listed.

CARD 1 (3I2)

N (columns 1-2)
M (columns 3-4)
NCT (columns 5-6)

CARD(S) 2 (6E11.5)

N=1 Z (columns 1-11)
 SA2 (columns 12-22)
 D2 (columns 23-33)
N=2 Z
 SA2
 D2
 etc.

Values of Z, SA2, and D2 are repeated in this manner until values for each blade region have been specified. As many cards as needed should be used to input the (3xN) values for these card(s) 2.

To start a new case, a new set of card(s)2 is included immediately after the previous card(s)2 set. Do not mix two cases on a single card, but start each new case on a fresh card.

This code is presently dimensioned to handle up to ten material regions. There is no limit to the number of cases that can be accomplished per run. The output of this code is labelled so as to be self-explanatory.

```

    IMPLICIT REAL*8 (A-H,O-Z)
    DIMENSION RK1(10),TK(10),AR(2,2),BR(2,2),CR(2,2),Z(10),D2(10),
1  SA1(10),SA2(10)
    READ(5,1) N,M,NCT
    1  FORMAT(3I2)
    DO 950 MCT=1,NCT
    READ(5,900) (Z(I),SA2(I),D2(I),I=1,N)
900  FORMAT(6E11.5)
    DO 4 J=1,N
    RK1(J)=DSQRT(SA2(J)/D2(J))
    WRITE(6,375) J,SA2(J),D2(J),Z(J)
375  FORMAT('  REG NO= ',I2,'  SA2= ',E11.5,'  D2= ',
+E11.5,'  REG SIZE= ',E11.5)
    4  TK(J)=RK1(J)*Z(J)/2.
C  HOMOGENIZES THE VARIOUS MATERIAL REGIONS
    AR(1,1)=DCOSH(TK(1))
    AR(1,2)=-DSINH(TK(1))/(D2(1)*RK1(1))
    AR(2,1)=-D2(1)*RK1(1)*DSINH(TK(1))
    AR(2,2)=DCCSH(TK(1))
    DO 6 K=2,N
    BR(1,1)=ICOSH(TK(K))
    BR(1,2)=-DSINH(TK(K))/(D2(K)*RK1(K))
    BR(2,1)=-D2(K)*RK1(K)*ISINH(TK(K))
    BR(2,2)=DCOSH(TK(K))
    DO 5 I=1,2
    DO 5 J=1,2
    5  CR(I,J)=AR(I,1)*BR(1,J)+AR(I,2)*BR(2,J)
    AR(1,1)=CR(1,1)
    AR(1,2)=CR(1,2)
    AR(2,1)=CR(2,1)
    6  AR(2,2)=CR(2,2)
    DO 380 I=1,2
    DO 380 J=1,2
    WRITE(6,385) I,J,AR(I,J)
385  FORMAT(' MATRIX ELEMENT ',I2,'-',I2,' = ',E11.5)

```

```

380 CONTINUE
C CALCULATES THE INVERSE CCSH
  X1=25.0
  X2=.1D-10
  7 X3=(X1+X2)/2.
  Y1=DCOSH(X1)-AR(1,1)
  Y3=DCOSH(X3)-AR(1,1)
  IF(DABS(Y3)-.00000001) 11,11,8
  8 IF(Y1*Y3) 9,11,10
  9 X2=X3
    GO TO 7
  10 X1=X3
    GO TO 7
  11 ZK2=X3
    DK2=DSQRT(AR(2,1)/AR(1,2))
C CALCULATES THE BLACKNESS CCEFFICIENTS AND THE MACROSCOPIC ABSORPTION
C CROSS-SECTION AND DIFFUSION CCEFFICIENT TO BE USED IF THE HOMOGENIZED REGION
C WERE TO BE DIVIDED INTO AN INFINITE NUMBER OF SECTIONS
  T=0.0
  DO 12 I=1,N
  12 T=T+Z(I)
    RK2=(ZK2/T)*2.
    D3=DK2/RK2
    SA3=D3*RK2*RK2
    A2=DSQRT(D3*SA3)*DTANH(RK2*T/2.)
    B2=DSQRT(D3*SA3)/DTANH(RK2*T/2.)
    WRITE(6,390) ZK2,DK2,RK2,D3,SA3
390  FORMAT(' ZK2= ',E11.5,'   DK2= ',E11.5,'   RK2= ',
+E11.5,'   D3= ',E11.5,'   SA3= ',E11.5)
    WRITE(6,400) A2,B2
400  FORMAT(' A2= ',E11.5,'   B2= ',E11.5)
C CALCULATES THE EFFECTIVE MESH CORRECTED ABSORPTION CROSS-SECTION AND DIFFUSION
C CCEFFICIENT
  H=T/M
  SA4=(2.*A2*B2)/(H*(B2-A2))
  D4=H*B2/2.

```

```
WRITE(6,13)SA4,D4
13 FORMAT(' SIGA = ',E11.5,' 1/CM',/,', ' D = ',E11.5,' CM')
950 CONTINUE
STOP
END
```

APPENDIX B

THREE DUMMY CORE CALCULATIONS

This appendix gives a comparison of the results of several CITATION calculations of three dummy core configurations with experimental data obtained from the original three dummy core. The configurations studied all include solid aluminum dummies in the A-1, B-2, and B-8 positions, with fixed absorbers in place in the central spider. The cases considered are:

- Case 1 - Experimental results of original three dummy core; fixed cadmium absorbers at 10" and cadmium shim blades at 7.6".
- Case 2 - CITATION results using old cadmium cross section set; fixed cadmium absorbers at 10" and cadmium shim blades at 8".
- Case 3 - CITATION results using new cadmium cross section set; fixed cadmium absorbers at 10" and cadmium shim blades at 8".
- Case 4 - CITATION results of potential core setup; fixed hafnium absorbers at 12" and boron-stainless-steel shim blades at 8".

The experimental data for Case 1 were obtained during the startup testing of the MITR-II, as described by Allen in Reference 14. The CITATION results were generated by use of a three-dimensional core model similar to that described in section 4.2 of the present work. The reactor power for each CITATION case was 5 MW.

The reactivity and technical specification limit "CITATION-only" results are listed in Table B-1. As stated in Chapter 2, the old cadmium cross section set greatly overpredicted the reactivity worth

TABLE B-1
RESULTS OF 3 DUMMY⁺ CORE STUDY

Case	Case Description	K_{eff}	Max. Safety Limit		Max. Operating Limit			F_R	F_A	Z
			value	position	value	position	height (inches)			
1	Experimental Data Cd fixed at 10" Cd blades at 7.6"	1.0000	2.17	C-8, at edge of core	3.53	C-9, at edge of core	5.4	1.27	2.29	.51
2	CITATION Data with <u>old</u> Cd cross section set Cd fixed at 10" Cd blades at 8"	.9468	1.94 ⁺⁺	C-9, at edge of core	3.84 ⁺⁺	C-9, at edge of core	6.1	1.26	2.38	.62
3	CITATION Data with <u>new</u> Cd cross section set Cd fixed at 10" Cd blades at 8"	.9830	1.91 ⁺⁺	C-8, at edge of core	3.30 ⁺⁺	C-9 at edge of core	6.1	1.24	2.16	.56
4	CITATION Data Hf fixed at 12" B-SS blades at 8"	.9879*	1.91 ⁺⁺	C-9, at edge of core	3.27 ⁺⁺	C-9, at edge of core	6.1	1.24	2.14	.55

⁺Dummies in core positions A-1, B-2, B-8

⁺⁺These are "CITATION-only" values, no prediction factors have been applied

*A slightly different axial mesh spacing was required to model this configuration, therefore, direct comparison of this value with the Case 2 & 3 values is not strictly appropriate.

of the cadmium fixed absorbers and cadmium shim blades. This can be seen by the low K_{eff} prediction of .9468 for Case 2. Case 3, with the new cadmium cross section data, still underpredicts the K_{eff} , but comes closer to the experimental result.

The predicted operating limit of 3.84 for Case 2 is the only limit which exceeds its maximum allowed value. However, the experimental value (Case 1) for this position was found to be 3.53, well below the maximum allowed operating limit of 3.72. The CITATION operating limit prediction was therefore conservative in this particular situation. CITATION was not conservative in predicting the safety limit for this case, and both limits are underpredicted by an even greater margin in Case 3.

The radial peaking factors (F_R) at the maximum operating limit for the first three cases are quite close. The axial peaking factors, however, vary considerably. The maximum predicted F_a value of the three is 2.38 for Case 2, while the smallest is 2.13 for Case 3. The experimental value lies between these two.

Table B-2 shows the calculated thermal fluxes along the core centerline at the height of the beam ports. As would be expected, the largest value is for Case 2 in which the artificially high absorption in the cadmium forces the power and flux toward the core bottom. Cases 3 and 4 predict values approximately 13% lower than Case 2.

TABLE B-2
BEAM PORT THERMAL FLUX VALUES GENERATED BY
CITATION FOR THE THREE DUMMY CORE STUDY

<u>Case</u>	<u>Beam Port Thermal Flux (n/cm²sec)</u>
2	1.08 x 10 ¹⁴
3	9.37 x 10 ¹³
4	9.33 x 10 ¹³

Figures B-1 through B-3 compare the power distributions along the core at three different locations. They show the product of the axial and radial peaking factors as a function of core height for positions A-2, B-5, and C-8. The experimental data which is presented was derived from the gamma-scanning of fuel plates.

The CITATION calculations generally underpredicted the power produced in the upper part of the core for the A and C-ring channels. The B-ring results for the four cases are fairly close in the upper core, but CITATION overpredicts the power density for most of the lower part of this element. The CITATION power peak results for the bottom edge of the core are consistently underestimated for the A and B-ring positions, but overestimated for the C-ring element. The effect of increasing the active core height to 12 inches can be seen in the Case 4 curves on Figures B-2 and B-3. For these B and C-ring core positions, the highest power density halfway up the core occurred for Case 4.

The next set of figures compare the thermal neutron flux distributions for each case. The experimental data (Case 1) was generated from a wire scan procedure as detailed in Reference 14. The magnitude of the flux was originally obtained in the units of counts per minute; a conversion was therefore needed to produce values of the flux. A factor of $186.5 \text{ counts/minute} = 10^{13} \text{ n/cm}^2 \text{ sec}$ (at 5 MW) was chosen by Allen after comparing the wire scan and CITATION results at the incore locations where the confidence in CITATION predictions is greatest.

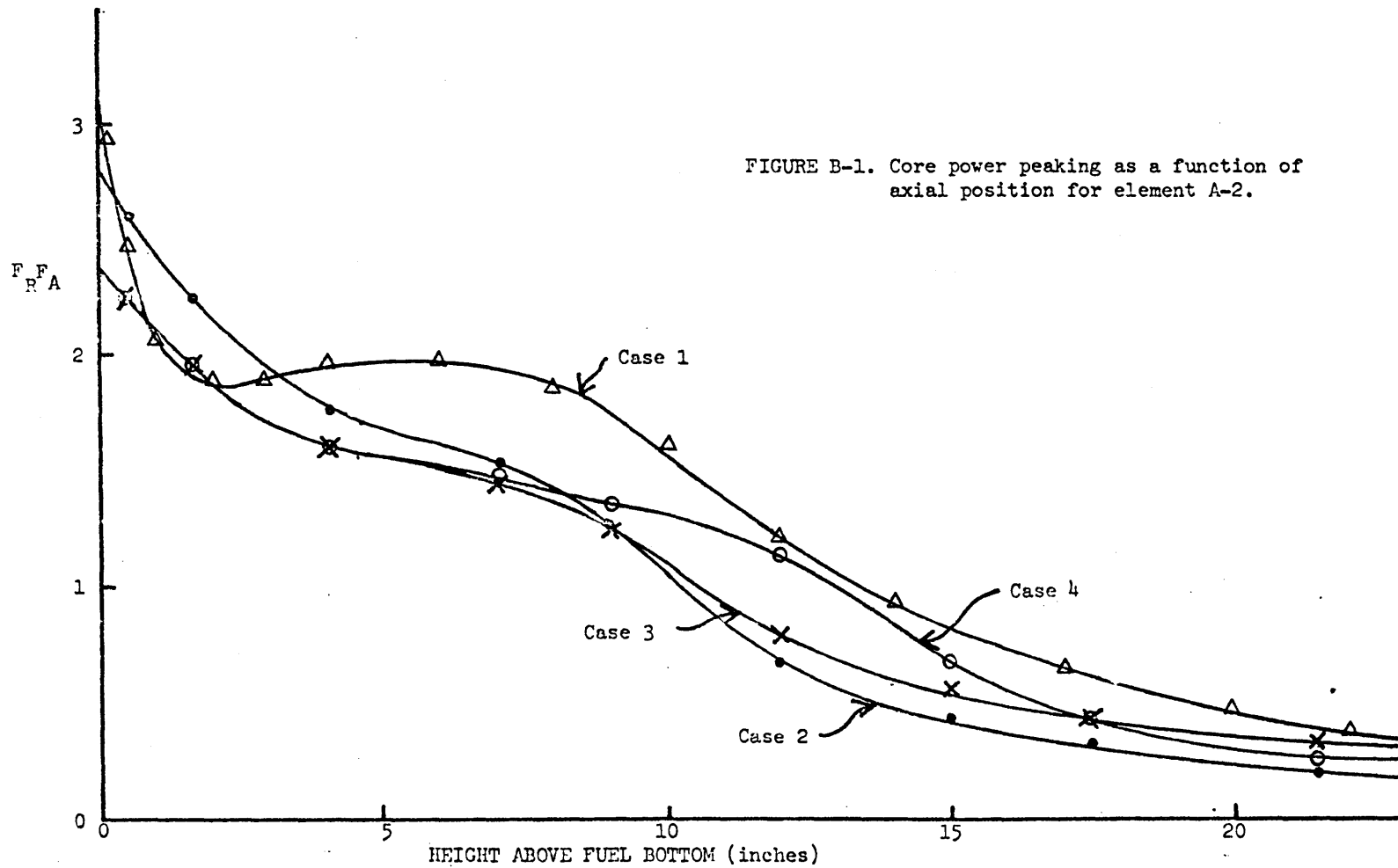

FIGURE B-1. Core power peaking as a function of axial position for element A-2.

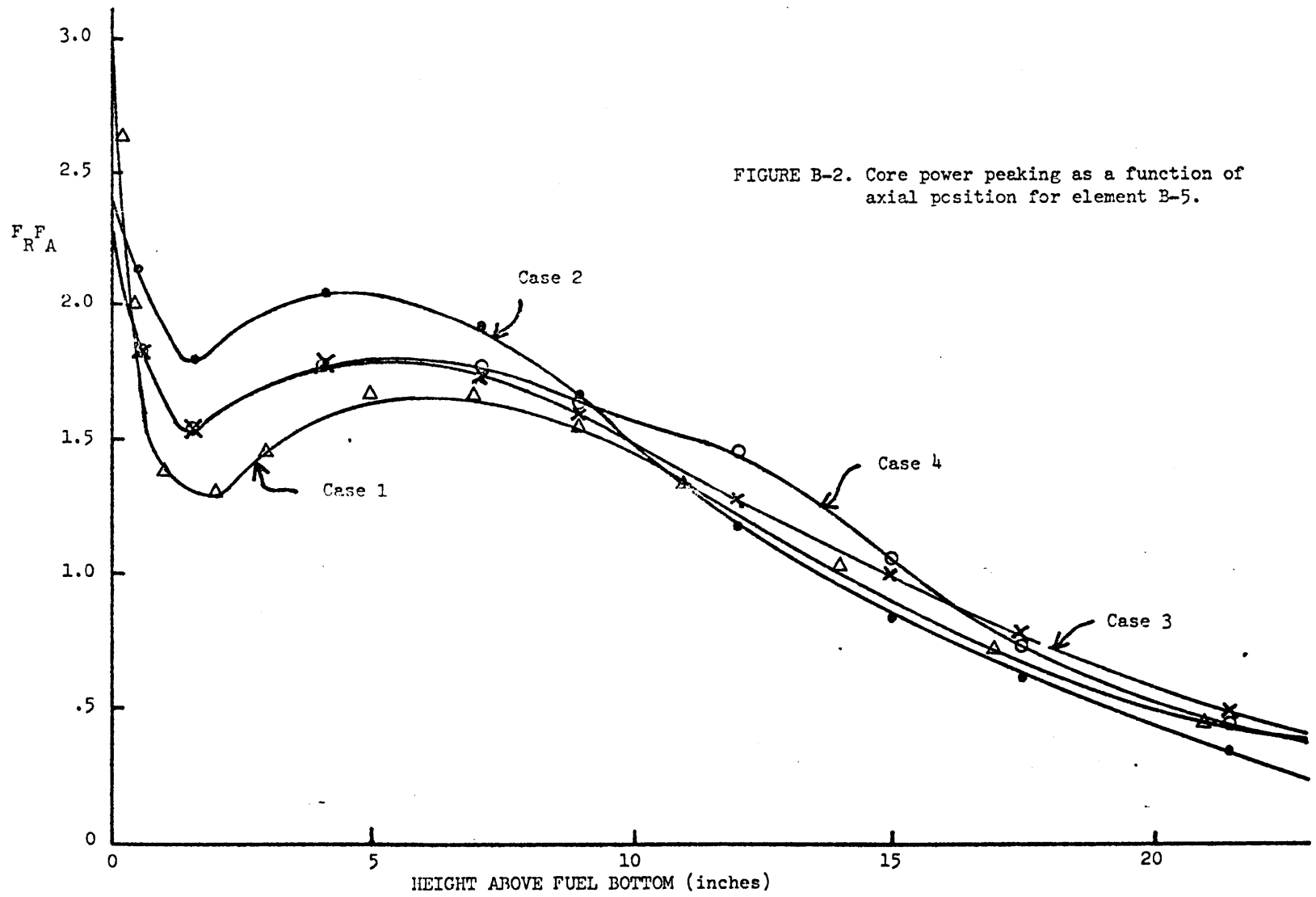

FIGURE B-2. Core power peaking as a function of axial position for element B-5.

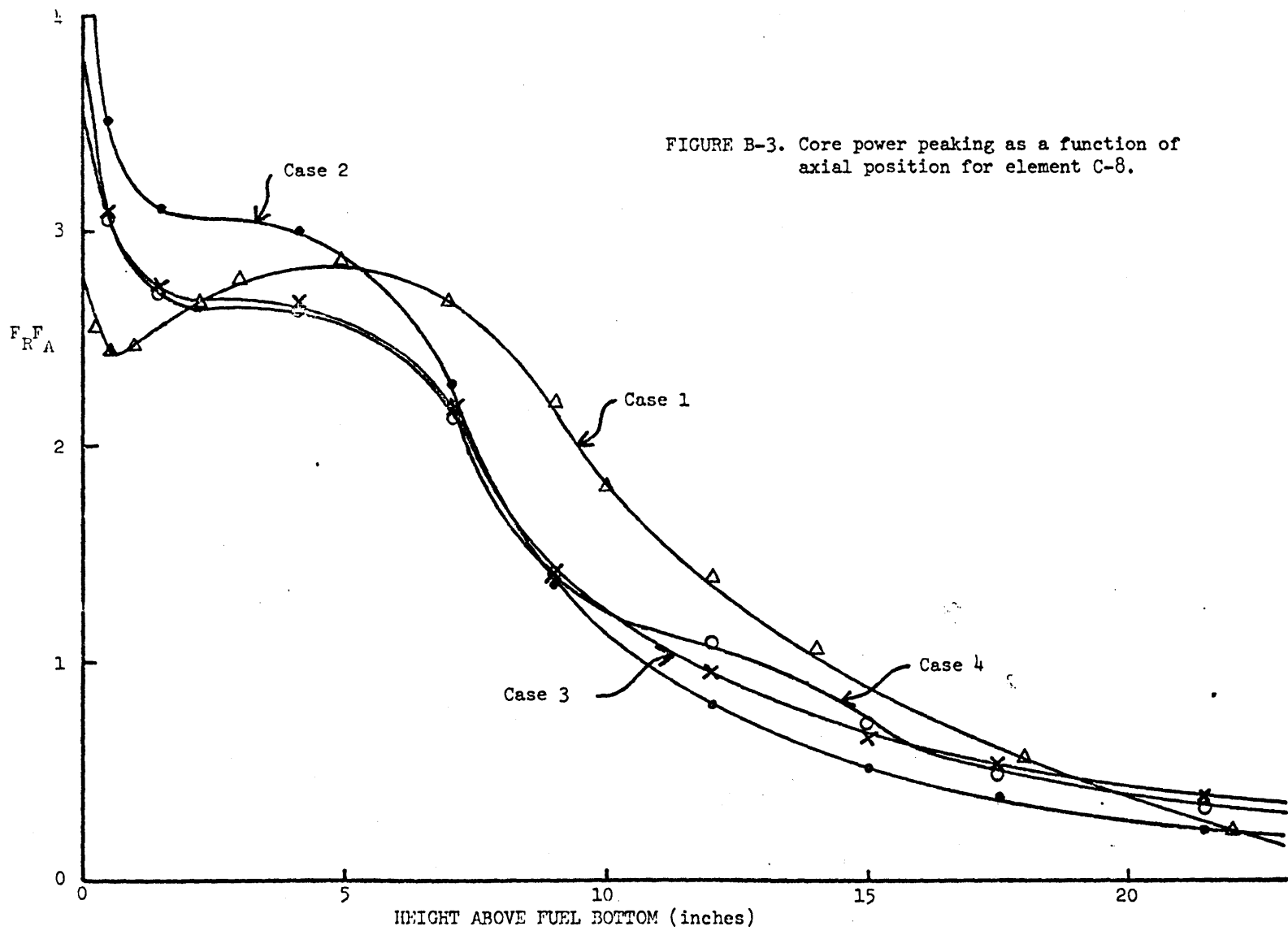

FIGURE B-3. Core power peaking as a function of axial position for element C-8.

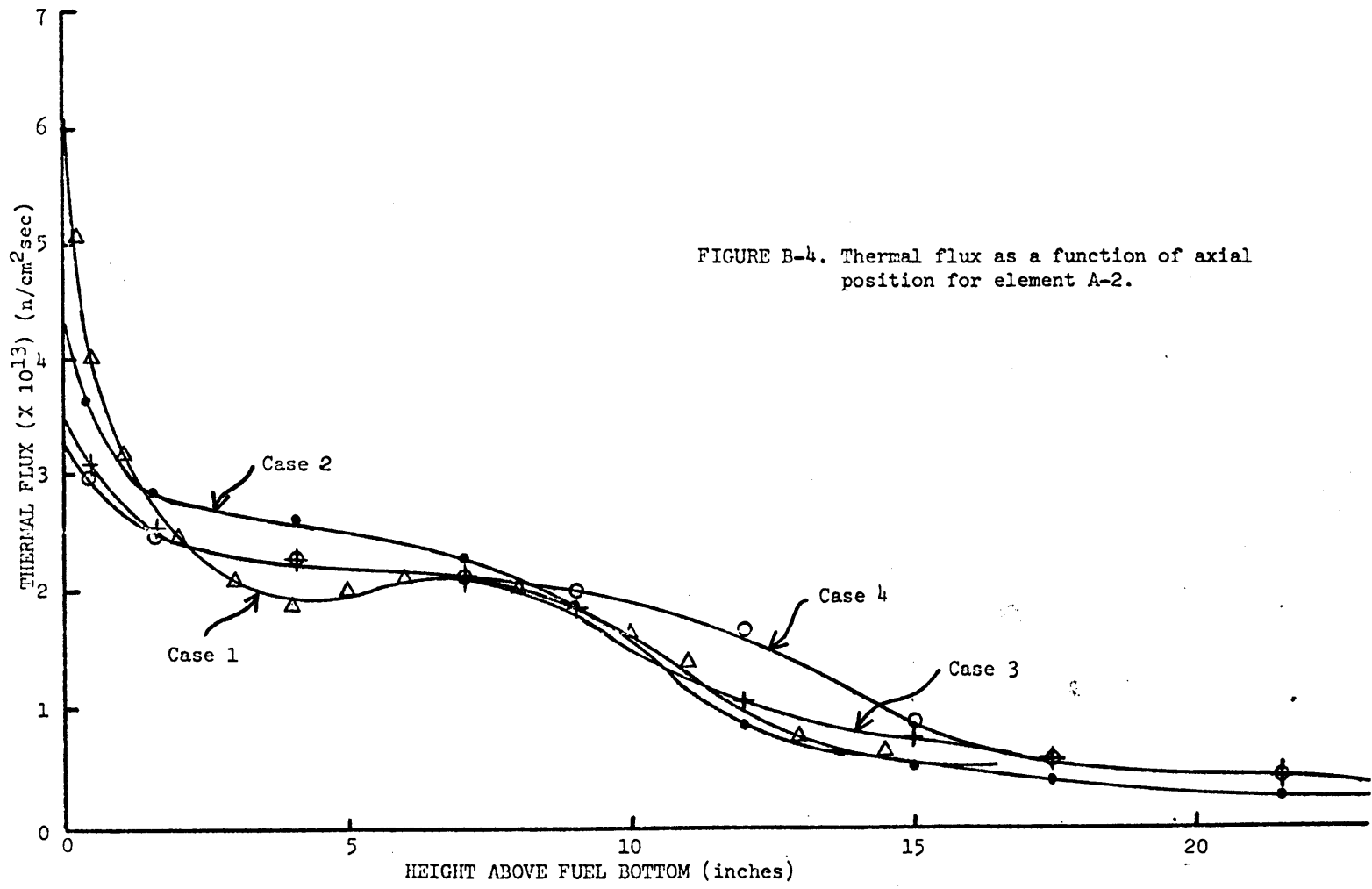
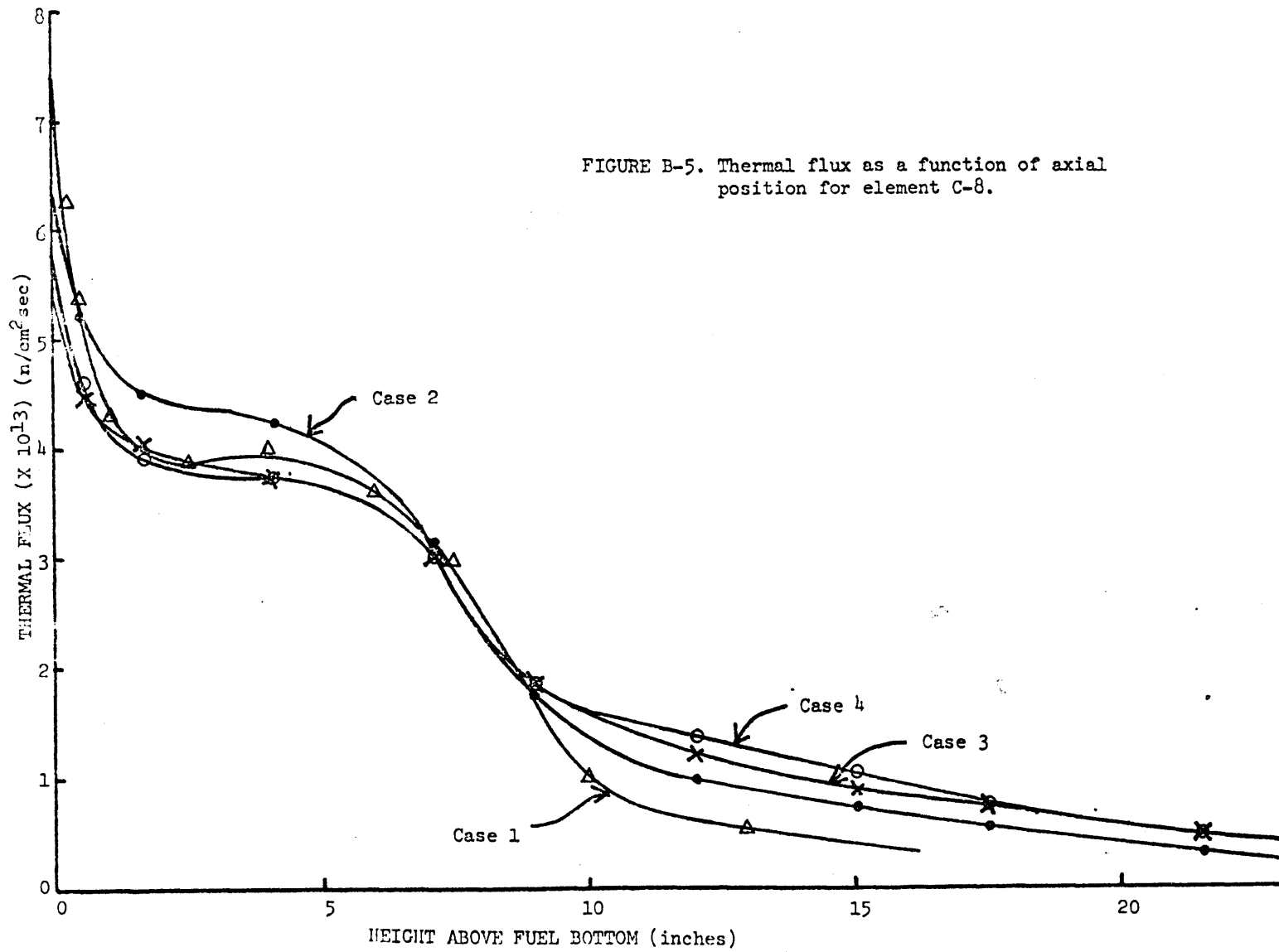
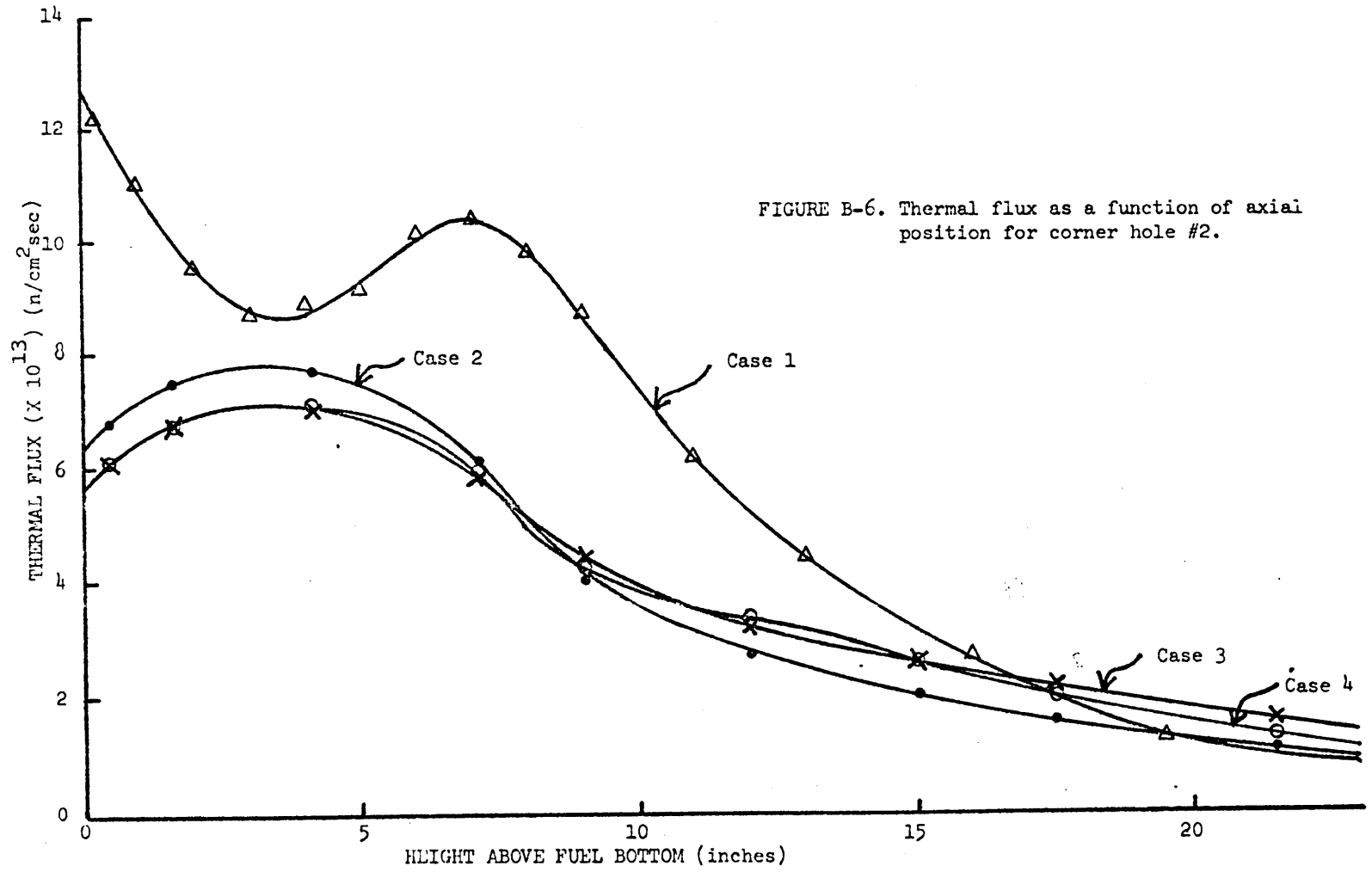

FIGURE B-4. Thermal flux as a function of axial position for element A-2.

FIGURE B-5. Thermal flux as a function of axial position for element C-8.





The core locations considered are the A-2 and C-8 core positions and the water filled corner hole #2, which is adjacent to core position C-3. At the two in-core locations, the CITATION calculations of cases 2 and 3 present a good approximation to the measured flux shape over most of the core's length. In the corner hole however, the CITATION values are consistently low. Once again, the CITATION calculations underpredict the peaking effect at the lower edge of the core. This is especially true in the corner hole positions.

APPENDIX C
THE COMPUTER CODE, LIMITS

This appendix describes a short computer code called LIMITS, which estimates the safety limit and the two-pump operating limit for the MITR-II. This program uses CITATION power density information to produce values for the radial peaking factor (F_R) the axial peaking factor (F_A), and the axial location factor (Z). Each of these factors are then multiplied by prediction factors which were developed by comparing experimental data with CITATION data (as shown in Tables 3-3 and 3-4). The choice of prediction factors depends upon the core configuration and the core location considered. Corrected values of F_R , F_A , and Z are then used in the equations which appear in Chapter 3 to find the predicted safety and operating limits.

Certain factors are written into this code as constants since they do not normally change from run to run. These are as follows:

<u>Factor</u>	<u>Constant Value</u>
F_H	1.211
F_P	1.000
d_{FC}	.887
W_{T0}	8.91×10^5 lbm/hr
W_T/W_{T0}	1.000 (since this code considers 2 pump operation)
C_P	.9985 BTU/lb-°F
F_0	1.55
η	1.9
F'_0	1.122
P_T	6.0 MW (since this code considers 2 pump operation)

Input Variables

The variable factors which must be input into the code are as follows:

	<u>Variable</u>	<u>Variable name in Code</u>	<u>Comments</u>
(1)	plenum flow disparity	DFP	A separate value must be input for each channel considered. These numbers have been empirically determined for 3 and 5 dummy cores, as listed in Table 3-2.
(2)	plane power densities	PD	These values are obtained from CITATION output, one is input for each fueled plane (starting at the core bottom) in each channel. (Units are w/cm ³)
(3)	number of fuel planes	NP	This is the number of axial segments into which the fuel is partitioned.
(4)	heat transfer coefficient - h _o	XHT	<p>Values for 3 and 5 dummy cores are listed in Table 3-1. Values for other core configurations are determined by use of the following equation:</p> $XHT = (32857.12 \frac{BTU}{hrft^2 \circ F}) (\frac{1}{N})^{.8}$ <p>where N = number of fueled core positions.</p>
(5)	surface area of fuel meat - A	PA	<p>Values for 3 and 5 dummy cores are listed in Table 3-1. Values for other core configurations are determined by use of the following equation:</p> $PA = (9.70 \text{ ft}^2)N.$
(6)	average power per square cm	APD	This factor equals the total reactor power divided by the fueled area in a horizontal slice across the core. (Units are w/cm ²)

- | | | | |
|------|---|------|---|
| (7) | fraction of flow cooling fuel - F_f | FF | Experimentally determined values for 3 and 5 dummy cores are listed in Table 3-1. |
| (8) | radial peaking prediction factor | PFR | This factor compensates for CITATIONS's error in predicting values for F_R . (See Tables 3-3 and 3-4.) |
| (9) | axial peaking prediction factors | PFA | These factors compensate for CITATION's error in predicting values for F_A . One value is input for each axial mesh surface in (or bordering on) a fueled plane. NP+1 values must be entered. (See Tables 3-3 and 3-4.) |
| (10) | axial location prediction factors | PFZ | These factors compensate for CITATION's error in predicting values for Z. One value is input for each axial mesh surface in (or bordering on) a fueled plane. NP+1 values must be entered. (See Tables 3-3 and 3-4.) |
| (11) | axial plane thickness | DELH | These are the distances between axial mesh surfaces within the fueled region starting with the thickness of the bottom fueled plane. (NP values must be entered.) (Units are cm.) |
| (12) | number of cases per start (defined below) | M | Each case is defined as a single channel investigated in a particular core configuration (start). A value for the variable DFP(#1 above), and a series (NP in number) of PD (#2) values are input for each case. |
| (13) | number of starts | L | This designates the number of different core configurations being considered. The variables NP, XHT, PA, APD, FF, PFR, PFA, PFZ, DELH, and M (#3 through 12) are input for each new start. If any of these variables are changed, a new start must be made. Single values are input for each of the variable numbers 3 through 8 and 12. A series of values (NP+1 in number) must be input for the variable numbers 9 through 11. |

Input Order

Variable factors are input on cards in the order outlined below.

The format for each card is also listed.

Card 1 (I2)

L (columns 1 - 2)

(A single card 1 is input each time the code is run.)

The following cards (2 - 6) are input for each new start:

Card 2 (2I2, 4E11.5)

M (columns 1 - 2)

NP (columns 3 - 4)

APD (5 - 16)

FF (17 - 28)

PA (29 - 40)

XHT (41 - 52)

Card 3 (E11.5)

PFR (columns 1 - 11)

Card(s) 4 (6E11.5)

PFA

(Values of PFA, starting at the fuel bottom, are input on as many cards as are needed. NP+1 values must be entered.)

Card(s) 5 (6E11.5)

PFZ

(Values of PFZ, starting at the fuel bottom, are input on as many cards as are needed. NP+1 values must be entered.)

NOTE: The first and last values of PFZ for any particular channel will always equal 1.000.)

Card(s) 6 (6E11.5)

DELH

(Values of DELH, starting with the bottom fueled plane, are input on as many cards as are needed. NP values must be entered.)

The following card(s) is/are input for each new case:

Card(s) 7 (6E11.5)

DFP (columns 1 - 11)

PD

(Values of PD, starting with the bottom fueled plane, are input on as many cards as are needed. NP values must be entered.)

A normal data input begins with a single card 1, followed by a set of cards 2 through 6 which provide information for the first start. One or more sets of card(s) 7 then follow; each set provides information concerning a particular channel in the core described by the start information (cards 2 - 6). If more than one start is to be made, a new set of start cards (2 - 6) will immediately follow the last of the channel information cards (7) of the previous start. There is no limitation on the number of starts which can be made, or on the number of cases that can be included under each start. The present dimensioning of the code allows for up to twelve axial mesh planes in the fueled core region. The output of the code is clearly labelled so as to be self-explanatory.

LIMITS develops the safety and operating limits only at specific points in the core. By the nature of the computer data which are available, it is impossible to find the **limits** at each core location, such as at every axial position along a hot channel. It would therefore be possible for the code to "average-over" a peak which actually occurs in the core. This fact must be considered when looking for the maximum safety and operating limits of a particular core setup.

```

DIMENSION DELH(12),ED(12),FA(12),Z(12),G(12),RRR(12),
+OL(12),QDH(12),QSUM(12),EFA(12),PFZ(12),SED(12),CFA(12)
1 READ(5,1) I
  FORMAT(I2)
  DO 25 J=1,I
2   READ(5,2) M,NP,APD,FF,PA,XHT
  FORMAT(2I2,4E11.5)
100  READ(5,100) PFR
  FORMAT(E11.5)
  READ(5,3) EFAND,(PFA(I),I=1,NP)
  READ(5,3) PFZND,(PFZ(I),I=1,NE)
  READ(5,3) (DELH(I),I=1,NE)
3   FORMAT(6E11.5)
  DO 25 JJ=1,M
4   READ(5,4) EFP,(PD(I),I=1,NP)
  FORMAT(6E11.5)
  SUBSUM=0.0
  DO 20 JJJ=1,NP
20  QDH(JJJ)=(ED(JJJ))*(DELH(JJJ))
  QSUM(JJJ)=SUBSUM+QDH(JJJ)
  SUBSUM=QSUM(JJJ)
  FR=(QSUM(NE))/APD
  FR=FR*PFR
  DF=(.887)*EFP
  SL=(1.211)*FR/(DF*FF)
  BUCK=0.0
  SEDND=0.0
  DO 18 K=1,NE
18  SED(K)=BUCK+DELH(K)/2.54
  BUCK=SED(K)
  FA(K)=(60.85)*PD(K)/QSUM(NE)
  DMZ=(DELH(1))/2.
  DMZZ=DELH(1)+(DELH(2))/2.
  FAND=(DMZ*FA(2)-DMZZ*FA(1))/(DMZ-DMZZ)
  FAND=FAND*EFAND
  ZND=0.0

```

```

PDND=(DMZ*ED(2)-DMZZ*PD(1))/(DMZ-DMZZ)
GND=((725778.12)*FR*FAND/(XHT*PA))/(FF*DF)**.8)
RRRND=2.77*((6.*FR*FAND/(1.9*PA))**.466)
OLND=GND-1.-RRRND
DO 205 K=1,NP
KPLUS=K+1
IF(K.EQ.NP) CFA(K)=FA(K)
IF(K.EQ.NP) GC TO 212
SEDBK=SED(K)-DELH(K)/2.0
SEDFO=SED(K)+DELH(KPLUS)/2.0
CFA(K)=FA(K)+(FA(KPLUS)-FA(K))*(SED(K)-SEDBK)/(SEDFO-SEDBK)
212 CFA(K)=PFA(K)*CFA(K)
Z(K)=QSUM(K)/QSUM(NP)
Z(K)=Z(K)*PFZ(K)
G(K)=((725778.12)*FR*CFA(K)/(XHT*PA))/(FF*DF)**.8)
RRR(K)=2.77*((6.*FR*CFA(K)/(1.9*PA))**.466)
205 OL(K)=1.122*FR*Z(K)/(DF*FF)+G(K)-1.0-RRR(K)
WRITE(6,5) J,JJ,FR,SL
5 FORMAT(' START # = ',I2,' CASE # = ',I2,' FR = ',
+E11.5,' SAFETY LIM = ',E11.5)
WRITE(6,8)
8 FORMAT(' ',/, ' ')
WRITE(6,6) SEDND,PDND,FAND,ZND,GND,OIND
6 FORMAT(' HEIGHT = ',E11.5,' P.D. = ',E11.5,
+' FA = ',E11.5,' Z = ',E11.5,' G = ',E11.5,
+' O.L. = ',E11.5)
DO 15 KK=1,NP
WRITE(6,6) SED(KK),PD(KK),FA(KK),Z(KK),G(KK),OL(KK)
15 CONTINUE
WRITE(6,101) DFP,APD,FF,FA,XHT
101 FORMAT(' DFP= ',E11.5,' APD= ',E11.5,' FF= ',E11.5,
+' PA= ',E11.5,' H= ',E11.5)
WRITE(6,7)
7 FORMAT(////////)
25 CONTINUE
STOP

```

APPENDIX D

SAMPLE CITATION OUTPUT

This appendix consists of an updated listing of the CITATION three group cross section set, followed by a sample output of a CITATION calculation. The calculation is that of a two dummy core with the molybdenum sample assembly in a flooded condition. This calculation is fully discussed in Section 4.2

EDIT OF CITATION CROSS SECTION TAPE FOLLOWS

CROSS SECTION SET 1

RECORD 1

TITLE ***** MICROSCOPIC CROSS-SECTIONS FOR THE MITR-II

RECORD 2

DATA TYPE, NO,NUCS, NO,GRPS, DWSCAT,UPSCAT, EXTRA -2 63 3 2 0 0

RECORD 3

GROUP CHIS

1.000000E+00 0.0 0.0

UPPER ENERGY OF EACH GROUP

1.000000E+06 3.000000E+03 4.000000E-01

MEAN ENERGY OF EACH GROUP

5.477200E+04 3.464000E+01 1.000000E-02

1/V SIGMA FOR EACH GROUP

1.990000E-09 2.778000E-07 4.247000E-06

DELAYED NEUT. PRECURSOR DECAY CONSTS.

1.240000E-02 3.050000E-02 1.110000E-01 3.010000E-01 1.140000E+00 3.010000E+00 0.0 0.0 0.0

0.0

GAMMA ENERGY STRUCTURE

0.0 0.0 0.0 0.0 0.0 0.0 0.0 0.0 0.0 0.0

0.0

RECORD 4

SIMPLE NUC.NO, OTHER NUC.NO, SIGMA IND,SCAT.IND, EXTRA 1 0 0 0 0

NAME *****

GENERAL DATA

0.0 0.0 3.225800E-11 0.0 0.0 0.0 0.0 0.0 0.0 0.0

0.0 0.0 0.0 0.0 0.0 0.0 0.0 0.0 0.0 0.0

0.0 0.0 0.0 0.0 0.0 0.0 0.0 0.0 0.0 0.0

0.0 0.0 0.0 0.0 0.0 0.0 0.0 0.0 0.0 0.0

0.0 0.0 0.0 0.0 5.200000E-04 3.460000E-03 3.100000E-03 6.239999E-03 1.820000E-03

6.599999E-04 0.0 0.0 0.0 0.0 0.0 0.0 0.0 0.0

0.0 0.0 0.0 0.0 0.0 0.0 0.0 0.0 0.0

RECORD 5

(SIGA(K), SIGF(K), SIGTR(K), SNU(K), SIGX(K), K=1,KMAX)/((SIGS(KK,K),KK=1,KMAX),K=1,KMAX)

2.049700E+00 1.742600E+00 6.579100E+00 2.553500E+00 0.0

4.012399E+01 2.842900E+01 4.452699E+01 2.449300E+00 0.0

4.325701E+02 3.687100E+02 4.413899E+02 2.442000E+00 0.0

0.0 4.755199E-03 0.0 0.0 0.0 4.420899E-03 0.0 0.0 0.0

RECORD 6

SIMPLE NUC.NO, OTHER NUC.NO, SIGMA IND,SCAT.IND, EXTRA 2 0 0 0 0

NAME *****

GENERAL DATA

0.0 0.0 3.225800E-11 0.0 0.0 0.0 0.0 0.0 0.0 0.0

0.0 0.0 0.0 0.0 0.0 0.0 0.0 0.0 0.0 0.0

0.0 0.0 0.0 0.0 0.0 0.0 0.0 0.0 0.0 0.0

0.0 0.0 0.0 0.0 0.0 0.0 0.0 0.0 0.0 0.0

0.0 0.0 0.0 0.0 0.0 0.0 0.0 0.0 0.0 0.0

0.0 0.0 0.0 0.0 0.0 0.0 0.0 0.0 0.0 0.0

RECORD 7

(SIGA(K), SIGF(K), SIGTR(K), SNU(K), SIGX(K), K=1,KMAX)/((SIGS(KK,K),KK=1,KMAX),K=1,KMAX)

3.730100E-01 1.247600E+00 6.554200E+00 1.107900E+00 0.0

3.007100E+01 0.0 2.641400E+01 0.0 0.0

1.813600E+00	0.0	9.135000E+00	0.0	0.0	0.0	5.305100E-03	0.0	0.0	0.0
0.0	5.706299E-03	0.0	0.0	0.0	0.0				
RECORD 8									
SIMPLE NUC.NO, OTHER NUC.NO, SIGMA IND, SCAT.IND, EXTRA				3	0	0	0	0	
NAME *****									
GENERAL DATA									
0.0	0.0	0.0	0.0	0.0	0.0	0.0	0.0	2.930000E+02	0.0
0.0	0.0	0.0	0.0	0.0	0.0	0.0	0.0	0.0	0.0
0.0	0.0	0.0	0.0	0.0	0.0	0.0	0.0	0.0	0.0
0.0	0.0	0.0	0.0	0.0	0.0	0.0	0.0	0.0	0.0
0.0	0.0	0.0	0.0	0.0	0.0	0.0	0.0	0.0	0.0
0.0	0.0	0.0	0.0	0.0	0.0	0.0	0.0	0.0	0.0
0.0	0.0	0.0	0.0	0.0	0.0	0.0	0.0	0.0	0.0
0.0	0.0	0.0	0.0	0.0	0.0	0.0	0.0	0.0	0.0
RECORD 9									
(SIGA(K), SIGF(K), SIGTR(K), SNU(K), SIGX(K), K=1,KMAX)/((SIGS(KK,K),KK=1,KMAX),K=1,KMAX)									
3.945801E-03	0.0	7.495900E+00	0.0	0.0	0.0				
3.551400E-02	0.0	2.170500E+01	0.0	0.0	0.0				
5.142500E-01	0.0	6.650301E+01	0.0	0.0	0.0				
0.0	2.116200E+00	0.0	0.0	0.0	0.0	4.043600E+00	0.0	0.0	0.0
RECORD 10									
SIMPLE NUC.NO, OTHER NUC.NO, SIGMA IND, SCAT.IND, EXTRA				4	0	0	0	0	
NAME *****									
GENERAL DATA									
0.0	0.0	0.0	0.0	0.0	0.0	0.0	0.0	0.0	0.0
0.0	0.0	0.0	0.0	0.0	0.0	0.0	0.0	0.0	0.0
0.0	0.0	0.0	0.0	0.0	0.0	0.0	0.0	0.0	0.0
0.0	0.0	0.0	0.0	0.0	0.0	0.0	0.0	0.0	0.0
0.0	0.0	0.0	0.0	0.0	0.0	0.0	0.0	0.0	0.0
0.0	0.0	0.0	0.0	0.0	0.0	0.0	0.0	0.0	0.0
0.0	0.0	0.0	0.0	0.0	0.0	0.0	0.0	0.0	0.0
0.0	0.0	0.0	0.0	0.0	0.0	0.0	0.0	0.0	0.0
RECORD 11									
(SIGA(K), SIGF(K), SIGTR(K), SNU(K), SIGX(K), K=1,KMAX)/((SIGS(KK,K),KK=1,KMAX),K=1,KMAX)									
3.696300E-03	0.0	2.685500E+00	0.0	0.0	0.0				
1.582500E-02	0.0	1.373900E+00	0.0	0.0	0.0				
2.263400E-01	0.0	1.466200E+00	0.0	0.0	0.0				
0.0	5.991600E-03	0.0	0.0	0.0	0.0	1.016800E-02	0.0	0.0	0.0
RECORD 12									
SIMPLE NUC.NO, OTHER NUC.NO, SIGMA IND, SCAT.IND, EXTRA				5	0	0	0	0	
NAME *****									
GENERAL DATA									
0.0	0.0	3.225800E-11	0.0	0.0	0.0	0.0	0.0	0.0	0.0
0.0	0.0	0.0	0.0	0.0	0.0	0.0	0.0	0.0	0.0
0.0	0.0	0.0	0.0	0.0	0.0	0.0	0.0	0.0	0.0
0.0	0.0	0.0	0.0	0.0	0.0	0.0	0.0	0.0	0.0
0.0	0.0	0.0	0.0	0.0	0.0	0.0	0.0	0.0	0.0
6.599999E-04	0.0	0.0	0.0	0.0	0.0	5.200000E-04	3.460000E-03	3.100000E-03	6.239999E-03
0.0	0.0	0.0	0.0	0.0	0.0	0.0	0.0	0.0	1.820000E-03
0.0	0.0	0.0	0.0	0.0	0.0	0.0	0.0	0.0	0.0
RECORD 13									
(SIGA(K), SIGF(K), SIGTR(K), SNU(K), SIGX(K), K=1,KMAX)/((SIGS(KK,K),KK=1,KMAX),K=1,KMAX)									
2.364100E+00	1.755100E+00	6.623800E+00	2.550800E+00	0.0	0.0				
4.003101E+01	2.834500E+01	4.443300E+01	2.449300E+00	0.0	0.0				
4.325701E+02	3.687100E+02	4.413899E+02	2.442000E+00	0.0	0.0				
0.0	4.865602E-03	0.0	0.0	0.0	0.0	4.365999E-03	0.0	0.0	0.0
RECORD 14									
SIMPLE NUC.NO, OTHER NUC.NO, SIGMA IND, SCAT.IND, EXTRA				6	0	0	0	0	
NAME *****									
GENERAL DATA									
0.0	0.0	3.225800E-11	0.0	0.0	0.0	0.0	0.0	0.0	0.0
0.0	0.0	0.0	0.0	0.0	0.0	0.0	0.0	0.0	0.0

0.0	0.0	0.0	0.0	0.0	0.0	0.0	0.0	0.0	0.0
0.0	0.0	0.0	0.0	0.0	0.0	0.0	0.0	0.0	0.0
0.0	0.0	0.0	0.0	0.0	0.0	0.0	0.0	0.0	0.0
0.0	0.0	0.0	0.0	0.0	0.0	0.0	0.0	0.0	0.0
0.0	0.0	0.0	0.0	0.0	0.0	0.0	0.0	0.0	0.0

RECORD 15

(SIGA(K), SIGF(K), SIGTR(K), SNU(K), SIGX(K), K=1,KMAX)/((SIGS(KK,K),KK=1,KMAX),K=1,KMAX)

3.711200E-01	1.252800E+00	6.603700E+00	1.093700E+00	0.0	0.0	0.0	0.0	0.0	0.0
3.003000E+01	0.0	2.644099E+01	0.0	0.0	0.0	0.0	0.0	0.0	0.0
1.813600E+00	0.0	7.135700E+00	0.0	0.0	0.0	0.0	0.0	0.0	0.0
0.0	5.833700E-03	0.0	0.0	0.0	5.239099E-03	0.0	0.0	0.0	0.0

RECORD 16

SIMPLE NUC.NO, OTHER NUC.NO, SIGMA IND, SCAT. IND, EXTRA 7 0 0 0 0

NAME *****

GENERAL DATA

0.0	0.0	0.0	0.0	0.0	0.0	0.0	0.0	2.930000E+02	0.0
0.0	0.0	0.0	0.0	0.0	0.0	0.0	0.0	0.0	0.0
0.0	0.0	0.0	0.0	0.0	0.0	0.0	0.0	0.0	0.0
0.0	0.0	0.0	0.0	0.0	0.0	0.0	0.0	0.0	0.0
0.0	0.0	0.0	0.0	0.0	0.0	0.0	0.0	0.0	0.0
0.0	0.0	0.0	0.0	0.0	0.0	0.0	0.0	0.0	0.0
0.0	0.0	0.0	0.0	0.0	0.0	0.0	0.0	0.0	0.0

RECORD 17

(SIGA(K), SIGF(K), SIGTR(K), SNU(K), SIGX(K), K=1,KMAX)/((SIGS(KK,K),KK=1,KMAX),K=1,KMAX)

3.778100E-03	0.0	7.584200E+00	0.0	0.0	0.0	0.0	0.0	0.0	0.0
3.525600E-02	0.0	2.170000E+01	0.0	0.0	0.0	0.0	0.0	0.0	0.0
5.142500E-01	0.0	6.650301E+01	0.0	0.0	0.0	0.0	0.0	0.0	0.0
0.0	2.164700E+00	0.0	0.0	0.0	4.001300E+00	0.0	0.0	0.0	0.0

RECORD 18

SIMPLE NUC.NO, OTHER NUC.NO, SIGMA IND, SCAT. IND, EXTRA 8 0 0 0 0

NAME *****

GENERAL DATA

0.0	0.0	0.0	0.0	0.0	0.0	0.0	0.0	0.0	0.0
0.0	0.0	0.0	0.0	0.0	0.0	0.0	0.0	0.0	0.0
0.0	0.0	0.0	0.0	0.0	0.0	0.0	0.0	0.0	0.0
0.0	0.0	0.0	0.0	0.0	0.0	0.0	0.0	0.0	0.0
0.0	0.0	0.0	0.0	0.0	0.0	0.0	0.0	0.0	0.0
0.0	0.0	0.0	0.0	0.0	0.0	0.0	0.0	0.0	0.0
0.0	0.0	0.0	0.0	0.0	0.0	0.0	0.0	0.0	0.0

RECORD 19

(SIGA(K), SIGF(K), SIGTR(K), SNU(K), SIGX(K), K=1,KMAX)/((SIGS(KK,K),KK=1,KMAX),K=1,KMAX)

3.391700E-03	0.0	2.694100E+00	0.0	0.0	0.0	0.0	0.0	0.0	0.0
1.571600E-02	0.0	1.373800E+00	0.0	0.0	0.0	0.0	0.0	0.0	0.0
2.263400E-01	0.0	1.466200E+00	0.0	0.0	0.0	0.0	0.0	0.0	0.0
0.0	6.130699E-03	0.0	0.0	0.0	1.004200E-02	0.0	0.0	0.0	0.0

RECORD 20

SIMPLE NUC.NO, OTHER NUC.NO, SIGMA IND, SCAT. IND, EXTRA 9 0 0 0 0

NAME *****

GENERAL DATA

0.0	0.0	3.225800E-11	0.0	0.0	0.0	0.0	0.0	0.0	0.0
0.0	0.0	0.0	0.0	0.0	0.0	0.0	0.0	0.0	0.0
0.0	0.0	0.0	0.0	0.0	0.0	0.0	0.0	0.0	0.0
0.0	0.0	0.0	0.0	0.0	0.0	0.0	0.0	0.0	0.0
0.0	0.0	0.0	0.0	0.0	5.200000E-04	3.460000E-03	3.100000E-03	6.239999E-03	1.820000E-03
6.599999E-04	0.0	0.0	0.0	0.0	0.0	0.0	0.0	0.0	0.0
0.0	0.0	0.0	0.0	0.0	0.0	0.0	0.0	0.0	0.0

RECORD 21

(SIGA(K), SIGF(K), SIGTR(K), SNU(K), SIGX(K), K=1,KMAX)/((SIGS(KK,K),KK=1,KMAX),K=1,KMAX)

2.067900E+00	1.757800E+00	6.633500E+00	2.550600E+00	0.0	0.0	0.0	0.0	0.0	0.0
--------------	--------------	--------------	--------------	-----	-----	-----	-----	-----	-----

3.950700E+01	2.790500E+01	4.391400E+01	2.449300E+00	0.0					
3.592200E+02	3.047700E+02	3.682200E+02	2.442000E+00	0.0					
0.0	4.889000E-03	0.0	0.0	0.0	4.114900E-03	0.0	0.0	0.0	0.0

RECORD 22
SIMPLE NUC.NO, OTHER NUC.NO, SIGMA IND, SCAT. IND, EXTRA 10 0 0 0 0
NAME *****
GENERAL DATA

0.0	0.0	3.225800E-11	0.0	0.0	0.0	0.0	0.0	0.0	0.0
0.0	0.0	0.0	0.0	0.0	0.0	0.0	0.0	0.0	0.0
0.0	0.0	0.0	0.0	0.0	0.0	0.0	0.0	0.0	0.0
0.0	0.0	0.0	0.0	0.0	0.0	0.0	0.0	0.0	0.0
0.0	0.0	0.0	0.0	0.0	0.0	0.0	0.0	0.0	0.0
0.0	0.0	0.0	0.0	0.0	0.0	0.0	0.0	0.0	0.0
0.0	0.0	0.0	0.0	0.0	0.0	0.0	0.0	0.0	0.0

RECORD 23
(SIGA(K), SIGF(K), SIGTR(K), SNU(K), SIGX(K), K=1,KMAX)/((SIGS(KK,K),KK=1,KMAX),K=1,KMAX)
3.722900E-01 1.244100E+00 6.614000E+00 1.082800E+00 0.0
2.969701E+01 0.0 2.648300E+01 0.0 0.0
1.520400E+00 0.0 8.989000E+00 0.0 0.0
0.0 5.866699E-03 0.0 0.0 0.0 4.937898E-03 0.0 0.0 0.0

RECORD 24
SIMPLE NUC.NO, OTHER NUC.NO, SIGMA IND, SCAT. IND, EXTRA 11 0 0 0 0
NAME *****
GENERAL DATA

0.0	0.0	0.0	0.0	0.0	0.0	0.0	0.0	0.0	0.0
0.0	0.0	0.0	0.0	0.0	0.0	0.0	0.0	0.0	0.0
0.0	0.0	0.0	0.0	0.0	0.0	0.0	0.0	0.0	0.0
0.0	0.0	0.0	0.0	0.0	0.0	0.0	0.0	0.0	0.0
0.0	0.0	0.0	0.0	0.0	0.0	0.0	0.0	0.0	0.0
0.0	0.0	0.0	0.0	0.0	0.0	0.0	0.0	0.0	0.0
0.0	0.0	0.0	0.0	0.0	0.0	0.0	0.0	0.0	0.0

RECORD 25
(SIGA(K), SIGF(K), SIGTR(K), SNU(K), SIGX(K), K=1,KMAX)/((SIGS(KK,K),KK=1,KMAX),K=1,KMAX)
3.518600E-03 0.0 2.085900E+00 0.0 0.0
1.535300E-02 0.0 1.376800E+00 0.0 0.0
1.975900E-01 0.0 1.536600E+00 0.0 0.0
0.0 6.159928E-03 0.0 0.0 0.0 9.464301E-03 0.0 0.0 0.0

RECORD 26
SIMPLE NUC.NO, OTHER NUC.NO, SIGMA IND, SCAT. IND, EXTRA 12 0 0 0 0
NAME *****
GENERAL DATA

0.0	0.0	0.0	0.0	0.0	0.0	0.0	0.0	2.930000E+02	0.0
0.0	0.0	0.0	0.0	0.0	0.0	0.0	0.0	0.0	0.0
0.0	0.0	0.0	0.0	0.0	0.0	0.0	0.0	0.0	0.0
0.0	0.0	0.0	0.0	0.0	0.0	0.0	0.0	0.0	0.0
0.0	0.0	0.0	0.0	0.0	0.0	0.0	0.0	0.0	0.0
0.0	0.0	0.0	0.0	0.0	0.0	0.0	0.0	0.0	0.0
0.0	0.0	0.0	0.0	0.0	0.0	0.0	0.0	0.0	0.0

RECORD 27
(SIGA(K), SIGF(K), SIGTR(K), SNU(K), SIGX(K), K=1,KMAX)/((SIGS(KK,K),KK=1,KMAX),K=1,KMAX)
3.752100E-03 0.0 7.587300E+00 0.0 0.0
3.408600E-02 0.0 2.167799E+01 0.0 0.0
4.237100E-01 0.0 5.701700E+01 0.0 0.0
0.0 2.175800E+00 0.0 0.0 0.0 3.812000E+00 0.0 0.0 0.0

RECORD 28
SIMPLE NUC.NO, OTHER NUC.NO, SIGMA IND, SCAT. IND, EXTRA 13 0 0 0 0
NAME *****
GENERAL DATA

0.0	0.0	0.0	0.0	0.0	0.0	0.0	0.0	0.0	0.0
-----	-----	-----	-----	-----	-----	-----	-----	-----	-----

0.0	0.0	0.0	0.0	0.0	0.0	0.0	0.0	0.0	0.0
0.0	0.0	0.0	0.0	0.0	0.0	0.0	0.0	0.0	0.0
0.0	0.0	0.0	0.0	0.0	0.0	0.0	0.0	0.0	0.0
0.0	0.0	0.0	0.0	0.0	0.0	0.0	0.0	0.0	0.0
0.0	0.0	0.0	0.0	0.0	0.0	0.0	0.0	0.0	0.0
0.0	0.0	0.0	0.0	0.0	0.0	0.0	0.0	0.0	0.0

RECORD 29
(SIGA(K), SIGF(K), SIGTR(K), SNU(K), SIGX(K), K=1,KMAX)/((SIGS(KK,K),KK=1,KMAX),K=1,KMAX)
3.608300E-03 0.0 2.084200E+00 0.0 0.0
1.524100E-02 0.0 1.373500E+00 0.0 0.0
1.904900E-01 0.0 1.444700E+00 0.0 0.0
0.0 6.065499E-03 0.0 0.0 0.0 9.511098E-03 0.0 0.0 0.0

RECORD 30
SIMPLE NUC.NO, OTHER NUC.NO, SIGMA IND, SCAT.IND, EXTRA 14 0 0 0 0
NAME *****
GENERAL DATA
0.0 0.0 0.0 0.0 0.0 0.0 0.0 2.930000E+02 0.0
0.0 0.0 0.0 0.0 0.0 0.0 0.0 0.0 0.0
0.0 0.0 0.0 0.0 0.0 0.0 0.0 0.0 0.0
0.0 0.0 0.0 0.0 0.0 0.0 0.0 0.0 0.0
0.0 0.0 0.0 0.0 0.0 0.0 0.0 0.0 0.0
0.0 0.0 0.0 0.0 0.0 0.0 0.0 0.0 0.0

RECORD 31
(SIGA(K), SIGF(K), SIGTR(K), SNU(K), SIGX(K), K=1,KMAX)/((SIGS(KK,K),KK=1,KMAX),K=1,KMAX)
3.914699E-03 0.0 7.506800E+00 0.0 0.0
3.418400E-02 0.0 2.167999E+01 0.0 0.0
4.291300E-01 0.0 5.757001E+01 0.0 0.0
0.0 2.142200E+00 0.0 0.0 0.0 3.828200E+00 0.0 0.0 0.0

RECORD 32
SIMPLE NUC.NO, OTHER NUC.NO, SIGMA IND, SCAT.IND, EXTRA 15 0 0 0 0
NAME *****
GENERAL DATA
0.0 0.0 3.225800E-11 0.0 0.0 0.0 0.0 0.0 0.0
0.0 0.0 0.0 0.0 0.0 0.0 0.0 0.0 0.0
0.0 0.0 0.0 0.0 0.0 0.0 0.0 0.0 0.0
0.0 0.0 0.0 0.0 0.0 0.0 0.0 0.0 0.0
0.0 0.0 0.0 0.0 0.0 5.200000E-04 3.460000E-03 3.100000E-03 6.239999E-03 1.820000E-03
6.599999E-04 0.0 0.0 0.0 0.0 0.0 0.0 0.0 0.0
0.0 0.0 0.0 0.0 0.0 0.0 0.0 0.0 0.0

RECORD 33
(SIGA(K), SIGF(K), SIGTR(K), SNU(K), SIGX(K), K=1,KMAX)/((SIGS(KK,K),KK=1,KMAX),K=1,KMAX)
2.957800E+00 1.751400E+00 6.598000E+00 2.553200E+00 0.0
3.953900E+01 2.793401E+01 4.394800E+01 2.449300E+00 0.0
3.534900E+02 3.085500E+02 3.724700E+02 2.442000E+00 0.0
0.0 4.813898E-03 0.0 0.0 0.0 4.135299E-03 0.0 0.0 0.0

RECORD 34
SIMPLE NUC.NO, OTHER NUC.NO, SIGMA IND, SCAT.IND, EXTRA 16 0 0 0 0
NAME *****
GENERAL DATA
0.0 0.0 3.225800E-11 0.0 0.0 0.0 0.0 0.0 0.0
0.0 0.0 0.0 0.0 0.0 0.0 0.0 0.0 0.0
0.0 0.0 0.0 0.0 0.0 0.0 0.0 0.0 0.0
0.0 0.0 0.0 0.0 0.0 0.0 0.0 0.0 0.0
0.0 0.0 0.0 0.0 0.0 0.0 0.0 0.0 0.0
0.0 0.0 0.0 0.0 0.0 0.0 0.0 0.0 0.0

RECORD 35
(SIGA(K), SIGF(K), SIGTR(K), SNU(K), SIGX(K), K=1,KMAX)/((SIGS(KK,K),KK=1,KMAX),K=1,KMAX)

3.748900E-01	1.233000E+00	6.573500E+00	1.105900E+00	0.0					
2.071500E+01	0.0	2.647301E+01	0.0	0.0					
1.538700E+03	0.0	8.598900E+00	0.0	0.0					
0.0	5.776700E-03	0.0	0.0	0.0	4.962299E-03	0.0	0.0	0.0	0.0

RECORD 36

SIMPLE NUC.NO, OTHER NUC.NO, SIGMA IND, SCAT. IND, EXTRA 17 0 0 0 0

NAME *****

GENERAL DATA

0.0	0.0	3.225800E-11	0.0	0.0	0.0	0.0	0.0	0.0	0.0
0.0	0.0	0.0	0.0	0.0	0.0	0.0	0.0	0.0	0.0
0.0	0.0	0.0	0.0	0.0	0.0	0.0	0.0	0.0	0.0
0.0	0.0	0.0	0.0	0.0	0.0	0.0	0.0	0.0	0.0
0.0	0.0	0.0	0.0	0.0	5.200000E-04	3.460000E-03	3.100000E-03	6.239999E-03	1.820000E-03
6.599999E-04	0.0	0.0	0.0	0.0	0.0	0.0	0.0	0.0	0.0
0.0	0.0	0.0	0.0	0.0	0.0	0.0	0.0	0.0	0.0

RECORD 37

(SIGA(K), SIGF(K), SIGTR(K), SNU(K), SIGX(K), K=1,KMAX)/((SIGS(KK,K),KK=1,KMAX),K=1,KMAX)

2.944000E+00	1.741700E+00	6.566700E+00	2.553900E+00	0.0					
3.994200E+01	2.826900E+01	4.435500E+01	2.449300E+00	0.0					
4.325701E+02	3.687100E+02	4.413899E+02	2.442000E+00	0.0					
0.0	4.704300E-03	0.0	0.0	0.0	4.306901E-03	0.0	0.0	0.0	0.0

RECORD 38

SIMPLE NUC.NO, OTHER NUC.NO, SIGMA IND, SCAT. IND, EXTRA 18 0 0 0 0

NAME *****

GENERAL DATA

0.0	0.0	3.225800E-11	0.0	0.0	0.0	0.0	0.0	0.0	0.0
0.0	0.0	0.0	0.0	0.0	0.0	0.0	0.0	0.0	0.0
0.0	0.0	0.0	0.0	0.0	0.0	0.0	0.0	0.0	0.0
0.0	0.0	0.0	0.0	0.0	0.0	0.0	0.0	0.0	0.0
0.0	0.0	0.0	0.0	0.0	0.0	0.0	0.0	0.0	0.0
0.0	0.0	0.0	0.0	0.0	0.0	0.0	0.0	0.0	0.0
0.0	0.0	0.0	0.0	0.0	0.0	0.0	0.0	0.0	0.0

RECORD 39

(SIGA(K), SIGF(K), SIGTR(K), SNU(K), SIGX(K), K=1,KMAX)/((SIGS(KK,K),KK=1,KMAX),K=1,KMAX)

3.733500E-01	1.246000E+00	6.452200E+00	1.112700E+00	0.0					
3.001300E+01	0.0	2.645500E+01	0.0	0.0					
1.813600E+03	0.0	9.135000E+00	0.0	0.0					
0.0	5.645100E-03	0.0	0.0	0.0	5.168300E-03	0.0	0.0	0.0	0.0

RECORD 40

SIMPLE NUC.NO, OTHER NUC.NO, SIGMA IND, SCAT. IND, EXTRA 19 0 0 0 0

NAME *****

GENERAL DATA

0.0	0.0	0.0	0.0	0.0	0.0	0.0	2.930000E+02	0.0	0.0
0.0	0.0	0.0	0.0	0.0	0.0	0.0	0.0	0.0	0.0
0.0	0.0	0.0	0.0	0.0	0.0	0.0	0.0	0.0	0.0
0.0	0.0	0.0	0.0	0.0	0.0	0.0	0.0	0.0	0.0
0.0	0.0	0.0	0.0	0.0	0.0	0.0	0.0	0.0	0.0
0.0	0.0	0.0	0.0	0.0	0.0	0.0	0.0	0.0	0.0
0.0	0.0	0.0	0.0	0.0	0.0	0.0	0.0	0.0	0.0

RECORD 41

(SIGA(K), SIGF(K), SIGTR(K), SNU(K), SIGX(K), K=1,KMAX)/((SIGS(KK,K),KK=1,KMAX),K=1,KMAX)

3.950201E-03	0.0	7.471400E+00	0.0	0.0					
3.510100E-02	0.0	2.169501E+01	0.0	0.0					
5.142500E-01	0.0	6.650301E+01	0.0	0.0					
0.0	2.095200E+00	0.0	0.0	0.0	3.969300E+00	0.0	0.0	0.0	0.0

RECORD 42

SIMPLE NUC.NO, OTHER NUC.NO, SIGMA IND, SCAT. IND, EXTRA 20 0 0 0 0

NAME *****

GENERAL DATA

```

(SIGA(K), SIGF(K), SIGTR(K), SNU(K), SIGX(K), K=1,KMAX)/((SIGS(KK,K),KK=1,KMAX),K=1,KMAX)
3.717300F-03 0.0 7.222000E+00 0.0 0.0
3.370600F-02 0.0 2.165900E+01 0.0 0.0
4.237100E-01 0.0 5.701700E+01 0.0 0.0
0.0 2.247600E+00 0.0 0.0 0.0 3.699400E+00 0.0 0.0 0.0

RECORD 50
SIMPLE NUC.NO, OTHER NUC.NO, SIGMA IND, SCAT. IND, EXTRA 24 0 0 0 0
NAME *****
GENERAL DATA
0.0 0.0 3.225800F-11 0.0 0.0 0.0 0.0 0.0 0.0 0.0
0.0 0.0 0.0 0.0 0.0 0.0 0.0 0.0 0.0 0.0
0.0 0.0 0.0 0.0 0.0 0.0 0.0 0.0 0.0 0.0
0.0 0.0 0.0 0.0 0.0 0.0 0.0 0.0 0.0 0.0
0.0 0.0 0.0 0.0 5.200000E-04 3.460000E-03 3.100000E-03 6.239999E-03 1.820000E-03
6.999999E-04 0.0 0.0 0.0 0.0 0.0 0.0 0.0 0.0
0.0 0.0 0.0 0.0 0.0 0.0 0.0 0.0 0.0

RECORD 51
(SIGA(K), SIGF(K), SIGTR(K), SNU(K), SIGX(K), K=1,KMAX)/((SIGS(KK,K),KK=1,KMAX),K=1,KMAX)
2.087000E+00 1.771400E+00 6.671900E+00 2.550000E+00 0.0
3.937100E+01 2.774200E+01 4.384100E+01 2.449400E+00 0.0
3.592200E+02 3.047700E+02 3.682200E+02 2.442000E+00 0.0
0.0 5.068600E-03 0.0 0.0 0.0 3.865200E-03 0.0 0.0 0.0

RECORD 52
SIMPLE NUC.NO, OTHER NUC.NO, SIGMA IND, SCAT. IND, EXTRA 25 0 0 0 0
NAME *****
GENERAL DATA
0.0 0.0 3.225800E-11 0.0 0.0 0.0 0.0 0.0 0.0 0.0
0.0 0.0 0.0 0.0 0.0 0.0 0.0 0.0 0.0 0.0
0.0 0.0 0.0 0.0 0.0 0.0 0.0 0.0 0.0 0.0
0.0 0.0 0.0 0.0 0.0 0.0 0.0 0.0 0.0 0.0
0.0 0.0 0.0 0.0 0.0 0.0 0.0 0.0 0.0 0.0
0.0 0.0 0.0 0.0 0.0 0.0 0.0 0.0 0.0 0.0
0.0 0.0 0.0 0.0 0.0 0.0 0.0 0.0 0.0 0.0

RECORD 53
(SIGA(K), SIGF(K), SIGTR(K), SNU(K), SIGX(K), K=1,KMAX)/((SIGS(KK,K),KK=1,KMAX),K=1,KMAX)
3.752200E-01 1.223900F+00 6.651400E+00 1.077000F+00 0.0
2.993100E+01 0.0 2.667799E+01 0.0 0.0
1.520400E+00 0.0 8.989000E+00 0.0 0.0
0.0 6.082300E-03 0.0 0.0 0.0 4.638199E-03 0.0 0.0 0.0

RECORD 54
SIMPLE NUC.NO, OTHER NUC.NO, SIGMA IND, SCAT. IND, EXTRA 26 0 0 0 0
NAME *****
GENERAL DATA
0.0 0.0 0.0 0.0 0.0 0.0 0.0 0.0 0.0 0.0
0.0 0.0 0.0 0.0 0.0 0.0 0.0 0.0 0.0 0.0
0.0 0.0 0.0 0.0 0.0 0.0 0.0 0.0 0.0 0.0
0.0 0.0 0.0 0.0 0.0 0.0 0.0 0.0 0.0 0.0
0.0 0.0 0.0 0.0 0.0 0.0 0.0 0.0 0.0 0.0
0.0 0.0 0.0 0.0 0.0 0.0 0.0 0.0 0.0 0.0
0.0 0.0 0.0 0.0 0.0 0.0 0.0 0.0 0.0 0.0

RECORD 55
(SIGA(K), SIGF(K), SIGTR(K), SNU(K), SIGX(K), K=1,KMAX)/((SIGS(KK,K),KK=1,KMAX),K=1,KMAX)
3.551900E-03 0.0 2.079200E+00 0.0 0.0
1.515400E-02 0.0 1.376700F+00 0.0 0.0
1.975900E-01 0.0 1.536600F+00 0.0 0.0
0.0 6.386399E-03 0.0 0.0 0.0 8.889899E-03 0.0 0.0 0.0

RECORD 56
SIMPLE NUC.NO, OTHER NUC.NO, SIGMA IND, SCAT. IND, EXTRA 27 0 0 0 0
NAME *****

```

GENERAL DATA

0.0	0.0	0.0	0.0	0.0	0.0	0.0	0.0	2.930000E+02	0.0
0.0	0.0	0.0	0.0	0.0	0.0	0.0	0.0	0.0	0.0
0.0	0.0	0.0	0.0	0.0	0.0	0.0	0.0	0.0	0.0
0.0	0.0	0.0	0.0	0.0	0.0	0.0	0.0	0.0	0.0
0.0	0.0	0.0	0.0	0.0	0.0	0.0	0.0	0.0	0.0
0.0	0.0	0.0	0.0	0.0	0.0	0.0	0.0	0.0	0.0
0.0	0.0	0.0	0.0	0.0	0.0	0.0	0.0	0.0	0.0

RECORD 57

{SIGA(K), SIGF(K), SIGTR(K), SNU(K), SIGX(K), K=1,KMAX)/{(SIGS(KK,K),KK=1,KMAX),K=1,KMAX}

3.712300E-03	0.0	7.622000E+00	0.0	0.0					
3.370600E-02	0.0	2.165900E+01	0.0	0.0					
4.237100E-01	0.0	5.701700E+01	0.0	0.0					
0.0	2.247600E+00	0.0	0.0	0.0	3.699400E+00	0.0	0.0	0.0	0.0

RECORD 58

SIMPLE NUC.NO, OTHER NUC.NO, SIGMA IND, SCAT.IND, EXTRA 28 0 0 0 0

NAME *****

GENERAL DATA

0.0	0.0	3.225800E-11	0.0	0.0	0.0	0.0	0.0	0.0	0.0
0.0	0.0	0.0	0.0	0.0	0.0	0.0	0.0	0.0	0.0
0.0	0.0	0.0	0.0	0.0	0.0	0.0	0.0	0.0	0.0
0.0	0.0	0.0	0.0	0.0	0.0	0.0	0.0	0.0	0.0
0.0	0.0	0.0	0.0	5.200000E-04	3.460000E-03	3.100000E-03	6.239999E-03	1.820000E-03	0.0
6.599999E-04	0.0	0.0	0.0	0.0	0.0	0.0	0.0	0.0	0.0
0.0	0.0	0.0	0.0	0.0	0.0	0.0	0.0	0.0	0.0

RECORD 59

{SIGA(K), SIGF(K), SIGTR(K), SNU(K), SIGX(K), K=1,KMAX)/{(SIGS(KK,K),KK=1,KMAX),K=1,KMAX}

2.064000E+00	1.756000E+00	6.607000E+00	2.593400E+00	0.0					
3.362199E+01	2.798500E+01	4.405400E+01	2.449300E+00	0.0					
3.592200E+02	3.047700E+02	3.662200E+02	2.442000E+00	0.0					
0.0	4.980499E-03	0.0	0.0	0.0	4.099399E-03	0.0	0.0	0.0	0.0

RECORD 60

SIMPLE NUC.NO, OTHER NUC.NO, SIGMA IND, SCAT.IND, EXTRA 29 0 0 0 0

NAME *****

GENERAL DATA

0.0	0.0	3.225800E-11	0.0	0.0	0.0	0.0	0.0	0.0	0.0
0.0	0.0	0.0	0.0	0.0	0.0	0.0	0.0	0.0	0.0
0.0	0.0	0.0	0.0	0.0	0.0	0.0	0.0	0.0	0.0
0.0	0.0	0.0	0.0	0.0	0.0	0.0	0.0	0.0	0.0
0.0	0.0	0.0	0.0	0.0	0.0	0.0	0.0	0.0	0.0
0.0	0.0	0.0	0.0	0.0	0.0	0.0	0.0	0.0	0.0
0.0	0.0	0.0	0.0	0.0	0.0	0.0	0.0	0.0	0.0

RECORD 61

{SIGA(K), SIGF(K), SIGTR(K), SNU(K), SIGX(K), K=1,KMAX)/{(SIGS(KK,K),KK=1,KMAX),K=1,KMAX}

3.769600E-01	1.220700E+00	6.581300E+00	1.108400E+00	0.0					
2.990500E+01	0.0	2.653999E+01	0.0	0.0					
1.520400E+00	0.0	8.989000E+00	0.0	0.0					
0.0	5.856600E-03	0.0	0.0	0.0	4.919302E-03	0.0	0.0	0.0	0.0

RECORD 62

SIMPLE NUC.NO, OTHER NUC.NO, SIGMA IND, SCAT.IND, EXTRA 30 0 0 0 0

NAME *****

GENERAL DATA

0.0	0.0	0.0	0.0	0.0	0.0	0.0	0.0	0.0	0.0
0.0	0.0	0.0	0.0	0.0	0.0	0.0	0.0	0.0	0.0
0.0	0.0	0.0	0.0	0.0	0.0	0.0	0.0	0.0	0.0
0.0	0.0	0.0	0.0	0.0	0.0	0.0	0.0	0.0	0.0
0.0	0.0	0.0	0.0	0.0	0.0	0.0	0.0	0.0	0.0
0.0	0.0	0.0	0.0	0.0	0.0	0.0	0.0	0.0	0.0
0.0	0.0	0.0	0.0	0.0	0.0	0.0	0.0	0.0	0.0

RECORD 63

(SIGA(K), SIGF(K), SIGTR(K), SNU(K), SIGX(K), K=1,KMAX)/((SIGS(KK,K),KK=1,KMAX),K=1,KMAX)
 3.065300E-03 0.0 2.081100E+00 0.0 0.0
 1.544900E-02 0.0 1.376900E+00 0.0 0.0
 1.975900E-01 0.0 1.536600E+00 0.0 0.0
 0.0 6.149400E-03 0.0 0.0 0.0 9.428699E-03 0.0 0.0 0.0

RECORD 64

SIMPLE NUC.NO, OTHER NUC.NO, SIGMA IND, SCAT.IND, EXTRA 31 0 0 0 0
 NAME *****
 GENERAL DATA
 0.0 0.0 0.0 0.0 0.0 0.0 0.0 2.930000E+02 0.0
 0.0 0.0 0.0 0.0 0.0 0.0 0.0 0.0 0.0
 0.0 0.0 0.0 0.0 0.0 0.0 0.0 0.0 0.0
 0.0 0.0 0.0 0.0 0.0 0.0 0.0 0.0 0.0
 0.0 0.0 0.0 0.0 0.0 0.0 0.0 0.0 0.0
 0.0 0.0 0.0 0.0 0.0 0.0 0.0 0.0 0.0
 0.0 0.0 0.0 0.0 0.0 0.0 0.0 0.0 0.0

RECORD 65

(SIGA(K), SIGF(K), SIGTR(K), SNU(K), SIGX(K), K=1,KMAX)/((SIGS(KK,K),KK=1,KMAX),K=1,KMAX)
 3.904500E-03 0.0 7.502300E+00 0.0 0.0
 3.432500E-02 0.0 2.167799E+01 0.0 0.0
 4.237100E-01 0.0 5.701700E+01 0.0 0.0
 0.0 2.165000E+00 0.0 0.0 0.0 3.830300E+00 0.0 0.0 0.0

RECORD 66

SIMPLE NUC.NO, OTHER NUC.NO, SIGMA IND, SCAT.IND, EXTRA 32 0 0 0 0
 NAME *****
 GENERAL DATA
 0.0 0.0 0.0 0.0 0.0 0.0 0.0 0.0 0.0
 0.0 0.0 0.0 0.0 0.0 0.0 0.0 0.0 0.0
 0.0 0.0 0.0 0.0 0.0 0.0 0.0 0.0 0.0
 0.0 0.0 0.0 0.0 0.0 0.0 0.0 0.0 0.0
 0.0 0.0 0.0 0.0 0.0 0.0 0.0 0.0 0.0
 0.0 0.0 0.0 0.0 0.0 0.0 0.0 0.0 0.0
 0.0 0.0 0.0 0.0 0.0 0.0 0.0 0.0 0.0

RECORD 67

(SIGA(K), SIGF(K), SIGTR(K), SNU(K), SIGX(K), K=1,KMAX)/((SIGS(KK,K),KK=1,KMAX),K=1,KMAX)
 3.779200E-03 0.0 7.721100E+00 0.0 0.0
 3.931800E-02 0.0 2.196800E+01 0.0 0.0
 6.127600E-01 0.0 7.769901E+01 0.0 0.0
 0.0 2.460200E+00 0.0 0.0 0.0 4.414800E+00 0.0 0.0 0.0

RECORD 68

SIMPLE NUC.NO, OTHER NUC.NO, SIGMA IND, SCAT.IND, EXTRA 33 0 0 0 0
 NAME *****
 GENERAL DATA
 0.0 0.0 0.0 0.0 0.0 0.0 0.0 0.0 0.0
 0.0 0.0 0.0 0.0 0.0 0.0 0.0 0.0 0.0
 0.0 0.0 0.0 0.0 0.0 0.0 0.0 0.0 0.0
 0.0 0.0 0.0 0.0 0.0 0.0 0.0 0.0 0.0
 0.0 0.0 0.0 0.0 0.0 0.0 0.0 0.0 0.0
 0.0 0.0 0.0 0.0 0.0 0.0 0.0 0.0 0.0
 0.0 0.0 0.0 0.0 0.0 0.0 0.0 0.0 0.0

RECORD 69

(SIGA(K), SIGF(K), SIGTR(K), SNU(K), SIGX(K), K=1,KMAX)/((SIGS(KK,K),KK=1,KMAX),K=1,KMAX)
 3.641300E-03 0.0 2.059400E+00 0.0 0.0
 1.708500E-02 0.0 1.378500E+00 0.0 0.0
 2.645800E-01 0.0 1.599100E+00 0.0 0.0
 0.0 7.061299E-03 0.0 0.0 0.0 1.125600E-02 0.0 0.0 0.0

RECORD 70

SIMPLE NUC.NO, OTHER NUC.NO, SIGMA IND, SCAT.IND, EXTRA 34 0 0 0 0

NAME *****
GENERAL DATA

0.0	0.0	0.0	0.0	0.0	0.0	0.0	0.0	0.0	0.0
0.0	0.0	0.0	0.0	0.0	0.0	0.0	0.0	0.0	0.0
0.0	0.0	0.0	0.0	0.0	0.0	0.0	0.0	0.0	0.0
0.0	0.0	0.0	0.0	0.0	0.0	0.0	0.0	0.0	0.0
0.0	0.0	0.0	0.0	0.0	0.0	0.0	0.0	0.0	0.0
0.0	0.0	0.0	0.0	0.0	0.0	0.0	0.0	0.0	0.0
0.0	0.0	0.0	0.0	0.0	0.0	0.0	0.0	0.0	0.0

RECORD 71

(SIGA(K), SIGP(K), SIGTR(K), SNU(K), SIGX(K), K=1,KMAX)/((SIGS(KK,K),KK=1,KMAX),K=1,KMAX)

3.104900E-03	0.0	5.880200E+00	0.0	0.0					
8.613002E-03	0.0	1.113400E+01	0.0	0.0					
4.800000E-02	0.0	1.113000E+01	0.0	0.0					
0.0	1.456000E-02	0.0	0.0	0.0	1.164000E-02	0.0	0.0	0.0	0.0

RECORD 72

SIMPLE NUC.NO, OTHER NUC.NO, SIGMA IND, SCAT.IND, EXTRA 35 0 0 0 0

NAME *****

GENERAL DATA

0.0	0.0	0.0	0.0	0.0	0.0	0.0	0.0	0.0	0.0
0.0	0.0	0.0	0.0	0.0	0.0	0.0	0.0	0.0	0.0
0.0	0.0	0.0	0.0	0.0	0.0	0.0	0.0	0.0	0.0
0.0	0.0	0.0	0.0	0.0	0.0	0.0	0.0	0.0	0.0
0.0	0.0	0.0	0.0	0.0	0.0	0.0	0.0	0.0	0.0
0.0	0.0	0.0	0.0	0.0	0.0	0.0	0.0	0.0	0.0
0.0	0.0	0.0	0.0	0.0	0.0	0.0	0.0	0.0	0.0

RECORD 73

(SIGA(K), SIGP(K), SIGTR(K), SNU(K), SIGX(K), K=1,KMAX)/((SIGS(KK,K),KK=1,KMAX),K=1,KMAX)

3.561900E-03	0.0	7.058800E+00	0.0	0.0					
1.541400E-02	0.0	1.377000E+00	0.0	0.0					
2.645800E-01	0.0	1.599100E+00	0.0	0.0					
0.0	7.218398E-03	0.0	0.0	0.0	8.331999E-03	0.0	0.0	0.0	0.0

RECORD 74

SIMPLE NUC.NO, OTHER NUC.NO, SIGMA IND, SCAT.IND, EXTRA 36 0 0 0 0

NAME *****

GENERAL DATA

0.0	0.0	0.0	0.0	0.0	0.0	0.0	0.0	0.0	0.0
0.0	0.0	0.0	0.0	0.0	0.0	0.0	0.0	0.0	0.0
0.0	0.0	0.0	0.0	0.0	0.0	0.0	0.0	0.0	0.0
0.0	0.0	0.0	0.0	0.0	0.0	0.0	0.0	0.0	0.0
0.0	0.0	0.0	0.0	0.0	0.0	0.0	0.0	0.0	0.0
0.0	0.0	0.0	0.0	0.0	0.0	0.0	0.0	0.0	0.0
0.0	0.0	0.0	0.0	0.0	0.0	0.0	0.0	0.0	0.0

RECORD 75

(SIGA(K), SIGP(K), SIGTR(K), SNU(K), SIGX(K), K=1,KMAX)/((SIGS(KK,K),KK=1,KMAX),K=1,KMAX)

6.357200E+00	0.0	6.266600E+00	0.0	0.0					
1.535400E+01	0.0	1.108100E+01	0.0	0.0					
3.803600E+06	0.0	1.408100E+02	0.0	0.0					
0.0	0.0	0.0	0.0	0.0	0.0	0.0	0.0	0.0	0.0

RECORD 76

SIMPLE NUC.NO, OTHER NUC.NO, SIGMA IND, SCAT.IND, EXTRA 37 0 0 0 0

NAME *****

GENERAL DATA

0.0	0.0	0.0	0.0	0.0	0.0	0.0	0.0	0.0	0.0
0.0	0.0	0.0	0.0	0.0	0.0	0.0	0.0	0.0	0.0
0.0	0.0	0.0	0.0	0.0	0.0	0.0	0.0	0.0	0.0
0.0	0.0	0.0	0.0	0.0	0.0	0.0	0.0	0.0	0.0
0.0	0.0	0.0	0.0	0.0	0.0	0.0	0.0	0.0	0.0
0.0	0.0	0.0	0.0	0.0	0.0	0.0	0.0	0.0	0.0
0.0	0.0	0.0	0.0	0.0	0.0	0.0	0.0	0.0	0.0

RECORD 77
 (SIGA(K), SIGF(K), SIGTR(K), SNU(K), SIGX(K), K=1,KMAX)/((SIGS(KK,K),KK=1,KMAX),K=1,KMAX)
 3.734400E-03 0.0 2.021400E+00 0.0 0.0
 1.768400E-02 0.0 1.379000E+00 0.0 0.0
 2.645800E-01 0.0 1.599100E+00 0.0 0.0
 0.0 8.894201E-03 0.0 0.0 0.0 1.222100E-02 0.0 0.0 0.0

RECORD 78
 SIMPLE NUC.NO, OTHER NUC.NO, SIGMA IND, SCAT.IND, EXTRA 38 0 0 0 0
 NAME *****

GENERAL DATA
 0.0 0.0 0.0 0.0 0.0 0.0 0.0 0.0 0.0
 0.0 0.0 0.0 0.0 0.0 0.0 0.0 0.0 0.0
 0.0 0.0 0.0 0.0 0.0 0.0 0.0 0.0 0.0
 0.0 0.0 0.0 0.0 0.0 0.0 0.0 0.0 0.0
 0.0 0.0 0.0 0.0 0.0 0.0 0.0 0.0 0.0
 0.0 0.0 0.0 0.0 0.0 0.0 0.0 0.0 0.0

RECORD 79
 (SIGA(K), SIGF(K), SIGTR(K), SNU(K), SIGX(K), K=1,KMAX)/((SIGS(KK,K),KK=1,KMAX),K=1,KMAX)
 2.855700E-03 0.0 2.084500E+00 0.0 0.0
 1.232900E-02 0.0 1.376900E+00 0.0 0.0
 1.980700E-01 0.0 1.536600E+00 0.0 0.0
 0.0 6.165601E-03 0.0 0.0 0.0 9.499501E-03 0.0 0.0 0.0

RECORD 80
 SIMPLE NUC.NO, OTHER NUC.NO, SIGMA IND, SCAT.IND, EXTRA 39 0 0 0 0
 NAME *****

GENERAL DATA
 0.0 0.0 0.0 0.0 0.0 0.0 0.0 0.0 0.0
 0.0 0.0 0.0 0.0 0.0 0.0 0.0 0.0 0.0
 0.0 0.0 0.0 0.0 0.0 0.0 0.0 0.0 0.0
 0.0 0.0 0.0 0.0 0.0 0.0 0.0 0.0 0.0
 0.0 0.0 0.0 0.0 0.0 0.0 0.0 0.0 0.0
 0.0 0.0 0.0 0.0 0.0 0.0 0.0 0.0 0.0

RECORD 81
 (SIGA(K), SIGF(K), SIGTR(K), SNU(K), SIGX(K), K=1,KMAX)/((SIGS(KK,K),KK=1,KMAX),K=1,KMAX)
 2.313000E-03 0.0 1.075400E+01 0.0 0.0
 5.295200E-02 0.0 2.236099E+01 0.0 0.0
 6.127600E-01 0.0 7.769901E+01 0.0 0.0
 0.0 6.084400E+00 0.0 0.0 0.0 6.543800E+00 0.0 0.0 0.0

RECORD 82
 SIMPLE NUC.NO, OTHER NUC.NO, SIGMA IND, SCAT.IND, EXTRA 40 0 0 0 0
 NAME *****

GENERAL DATA
 0.0 0.0 0.0 0.0 0.0 0.0 0.0 0.0 0.0
 0.0 0.0 0.0 0.0 0.0 0.0 0.0 0.0 0.0
 0.0 0.0 0.0 0.0 0.0 0.0 0.0 0.0 0.0
 0.0 0.0 0.0 0.0 0.0 0.0 0.0 0.0 0.0
 0.0 0.0 0.0 0.0 0.0 0.0 0.0 0.0 0.0
 0.0 0.0 0.0 0.0 0.0 0.0 0.0 0.0 0.0

RECORD 83
 (SIGA(K), SIGF(K), SIGTR(K), SNU(K), SIGX(K), K=1,KMAX)/((SIGS(KK,K),KK=1,KMAX),K=1,KMAX)
 3.885400E-03 0.0 1.831900E+00 0.0 0.0
 2.287900E-02 0.0 1.384100E+00 0.0 0.0
 2.645800E-01 0.0 1.599100E+00 0.0 0.0
 0.0 1.868800E-02 0.0 0.0 0.0 1.790700E-02 0.0 0.0 0.0

RECORD 84

Information Processing Center

Information Processing Center

Information Processing Center

Information Processing Center

SIMPLE NUC.NO, OTHER NUC.NO, SIGMA INC, SCAT.IND, EXTRA 41 0 0 0 0

NAME *****

GENERAL DATA

0.0	0.0	0.0	0.0	0.0	0.0	0.0	0.0	0.0	0.0
0.0	0.0	0.0	0.0	0.0	0.0	0.0	0.0	0.0	0.0
0.0	0.0	0.0	0.0	0.0	0.0	0.0	0.0	0.0	0.0
0.0	0.0	0.0	0.0	0.0	0.0	0.0	0.0	0.0	0.0
0.0	0.0	0.0	0.0	0.0	0.0	0.0	0.0	0.0	0.0
0.0	0.0	0.0	0.0	0.0	0.0	0.0	0.0	0.0	0.0
0.0	0.0	0.0	0.0	0.0	0.0	0.0	0.0	0.0	0.0
0.0	0.0	0.0	0.0	0.0	0.0	0.0	0.0	0.0	0.0

RECORD 85

(SIGA(K), SIGF(K), SIGTR(K), SNU(K), SIGX(K), K=1,KMAX)/((SIGS(KK,K),KK=1,KMAX),K=1,KMAX)

0.0	0.0	3.09330E+00	0.0	0.0					
1.017000E-04	0.0	4.40230E+00	0.0	0.0					
2.991200E-03	0.0	4.71870E+00	0.0	0.0					
0.0	1.099700E-01	0.0	0.0	0.0	1.227400E-01	0.0	0.0	0.0	0.0

RECORD 86

SIMPLE NUC.NO, OTHER NUC.NO, SIGMA INC, SCAT.IND, EXTRA 42 0 0 0 0

NAME *****

GENERAL DATA

0.0	0.0	0.0	0.0	0.0	0.0	0.0	0.0	0.0	0.0
0.0	0.0	0.0	0.0	0.0	0.0	0.0	0.0	0.0	0.0
0.0	0.0	0.0	0.0	0.0	0.0	0.0	0.0	0.0	0.0
0.0	0.0	0.0	0.0	0.0	0.0	0.0	0.0	0.0	0.0
0.0	0.0	0.0	0.0	0.0	0.0	0.0	0.0	0.0	0.0
0.0	0.0	0.0	0.0	0.0	0.0	0.0	0.0	0.0	0.0
0.0	0.0	0.0	0.0	0.0	0.0	0.0	0.0	0.0	0.0
0.0	0.0	0.0	0.0	0.0	0.0	0.0	0.0	0.0	0.0
0.0	0.0	0.0	0.0	0.0	0.0	0.0	0.0	0.0	0.0

RECORD 87

(SIGA(K), SIGF(K), SIGTR(K), SNU(K), SIGX(K), K=1,KMAX)/((SIGS(KK,K),KK=1,KMAX),K=1,KMAX)

3.363100E-03	0.0	6.69220E+00	0.0	0.0					
2.361000E-05	0.0	8.31270E+00	0.0	0.0					
9.863300E-04	0.0	1.20160E+01	0.0	0.0					
0.0	4.388400E-01	0.0	0.0	0.0	5.633600E-01	0.0	0.0	0.0	0.0

RECORD 88

SIMPLE NUC.NO, OTHER NUC.NO, SIGMA INC, SCAT.IND, EXTRA 43 0 0 0 0

NAME *****

GENERAL DATA

0.0	0.0	0.0	0.0	0.0	0.0	0.0	0.0	0.0	0.0
0.0	0.0	0.0	0.0	0.0	0.0	0.0	0.0	0.0	0.0
0.0	0.0	0.0	0.0	0.0	0.0	0.0	0.0	0.0	0.0
0.0	0.0	0.0	0.0	0.0	0.0	0.0	0.0	0.0	0.0
0.0	0.0	0.0	0.0	0.0	0.0	0.0	0.0	0.0	0.0
0.0	0.0	0.0	0.0	0.0	0.0	0.0	0.0	0.0	0.0
0.0	0.0	0.0	0.0	0.0	0.0	0.0	0.0	0.0	0.0
0.0	0.0	0.0	0.0	0.0	0.0	0.0	0.0	0.0	0.0
0.0	0.0	0.0	0.0	0.0	0.0	0.0	0.0	0.0	0.0

RECORD 89

(SIGA(K), SIGF(K), SIGTR(K), SNU(K), SIGX(K), K=1,KMAX)/((SIGS(KK,K),KK=1,KMAX),K=1,KMAX)

3.734400E-03	0.0	2.02140E+00	0.0	0.0					
1.768400E-02	0.0	1.37900E+00	0.0	0.0					
2.645800E-01	0.0	1.55910E+00	0.0	0.0					
0.0	8.894201E-03	0.0	0.0	0.0	1.222100E-02	0.0	0.0	0.0	0.0

RECORD 90

SIMPLE NUC.NO, OTHER NUC.NO, SIGMA INC, SCAT.IND, EXTRA 44 0 0 0 0

NAME *****

GENERAL DATA

0.0	0.0	0.0	0.0	0.0	0.0	0.0	0.0	0.0	0.0
0.0	0.0	0.0	0.0	0.0	0.0	0.0	0.0	0.0	0.0
0.0	0.0	0.0	0.0	0.0	0.0	0.0	0.0	0.0	0.0
0.0	0.0	0.0	0.0	0.0	0.0	0.0	0.0	0.0	0.0
0.0	0.0	0.0	0.0	0.0	0.0	0.0	0.0	0.0	0.0
0.0	0.0	0.0	0.0	0.0	0.0	0.0	0.0	0.0	0.0
0.0	0.0	0.0	0.0	0.0	0.0	0.0	0.0	0.0	0.0
0.0	0.0	0.0	0.0	0.0	0.0	0.0	0.0	0.0	0.0
0.0	0.0	0.0	0.0	0.0	0.0	0.0	0.0	0.0	0.0

Information Processing Center

Information Processing Center

0.0	0.0	0.0	0.0	0.0	0.0	0.0	0.0	0.0	0.0
-----	-----	-----	-----	-----	-----	-----	-----	-----	-----

RECORD 91
(SIGA(K), SIGF(K), SIGTR(K), SNU(K), SIGX(K), K=1,KMAX)/((SIGS(KK,K),KK=1,KMAX),K=1,KMAX)
4.654299E-03 0.0 7.133900E+00 0.0 0.0
4.238200E-02 0.0 2.204900E+01 0.0 0.0
6.127600E-01 0.0 7.769901E+01 0.0 0.0
0.0 2.233700E+00 0.0 0.0 0.0 4.875800E+00 0.0 0.0 0.0

Information Processing Center

RECORD 92
SIMPLE NUC.NO, OTHER NUC.NO, SIGMA IND, SCAT.IND, EXTRA 45 0 0 0 0
NAME *****
GENERAL DATA
0.0 0.0 0.0 0.0 0.0 0.0 0.0 0.0 0.0
0.0 0.0 0.0 0.0 0.0 0.0 0.0 0.0 0.0
0.0 0.0 0.0 0.0 0.0 0.0 0.0 0.0 0.0
0.0 0.0 0.0 0.0 0.0 0.0 0.0 0.0 0.0
0.0 0.0 0.0 0.0 0.0 0.0 0.0 0.0 0.0
0.0 0.0 0.0 0.0 0.0 0.0 0.0 0.0 0.0

RECORD 93
(SIGA(K), SIGF(K), SIGTR(K), SNU(K), SIGX(K), K=1,KMAX)/((SIGS(KK,K),KK=1,KMAX),K=1,KMAX)
4.188702E-03 0.0 7.503900E+00 0.0 0.0
4.107700E-02 0.0 2.200500E+01 0.0 0.0
6.127600E-01 0.0 7.769901E+01 0.0 0.0
0.0 2.516300E+00 0.0 0.0 0.0 4.654400E+00 0.0 0.0 0.0

RECORD 94
SIMPLE NUC.NO, OTHER NUC.NO, SIGMA IND, SCAT.IND, EXTRA 46 0 0 0 0
NAME *****
GENERAL DATA
0.0 0.0 0.0 0.0 0.0 0.0 0.0 0.0 0.0
0.0 0.0 0.0 0.0 0.0 0.0 0.0 0.0 0.0
0.0 0.0 0.0 0.0 0.0 0.0 0.0 0.0 0.0
0.0 0.0 0.0 0.0 0.0 0.0 0.0 0.0 0.0
0.0 0.0 0.0 0.0 0.0 0.0 0.0 0.0 0.0
0.0 0.0 0.0 0.0 0.0 0.0 0.0 0.0 0.0

Information Processing Center

RECORD 95
(SIGA(K), SIGF(K), SIGTR(K), SNU(K), SIGX(K), K=1,KMAX)/((SIGS(KK,K),KK=1,KMAX),K=1,KMAX)
3.797900E-03 0.0 2.037900E+00 0.0 0.0
1.702600E-02 0.0 1.379200E+00 0.0 0.0
2.649800E-01 0.0 1.599100E+00 0.0 0.0
0.0 7.282600E-03 0.0 0.0 0.0 1.184100E-02 0.0 0.0 0.0

RECORD 96
SIMPLE NUC.NO, OTHER NUC.NO, SIGMA IND, SCAT.IND, EXTRA 47 0 0 0 0
NAME *****
GENERAL DATA
0.0 0.0 0.0 0.0 0.0 0.0 0.0 2.930000E+02 0.0
0.0 0.0 0.0 0.0 0.0 0.0 0.0 0.0 0.0
0.0 0.0 0.0 0.0 0.0 0.0 0.0 0.0 0.0
0.0 0.0 0.0 0.0 0.0 0.0 0.0 0.0 0.0
0.0 0.0 0.0 0.0 0.0 0.0 0.0 0.0 0.0
0.0 0.0 0.0 0.0 0.0 0.0 0.0 0.0 0.0

RECORD 97
(SIGA(K), SIGF(K), SIGTR(K), SNU(K), SIGX(K), K=1,KMAX)/((SIGS(KK,K),KK=1,KMAX),K=1,KMAX)
3.607100E-03 0.0 8.045800E+00 0.0 0.0
4.057900E-02 0.0 2.200700E+01 0.0 0.0
6.127600E-01 0.0 7.769901E+01 0.0 0.0
0.0 2.798200E+00 0.0 0.0 0.0 4.617100E+00 0.0 0.0 0.0

RECORD 98
 SIMPLE NUC.NO, OTHER NUC.NO, SIGMA IND, SCAT.IND, EXTRA 48 0 0 0 0
 NAME *****
 GENERAL DATA

0.0	0.0	0.0	0.0	0.0	0.0	0.0	0.0	0.0
0.0	0.0	0.0	0.0	0.0	0.0	0.0	0.0	0.0
0.0	0.0	0.0	0.0	0.0	0.0	0.0	0.0	0.0
0.0	0.0	0.0	0.0	0.0	0.0	0.0	0.0	0.0
0.0	0.0	0.0	0.0	0.0	0.0	0.0	0.0	0.0
0.0	0.0	0.0	0.0	0.0	0.0	0.0	0.0	0.0
0.0	0.0	0.0	0.0	0.0	0.0	0.0	0.0	0.0

Information Processed Center

RECORD 99
 (SIGA(K), SIGF(K), SIGTR(K), SNU(K), SIGX(K), K=1,KMAX)/((SIGS(KK,K),KK=1,KMAX),K=1,KMAX)
 3.493600E-03 0.0 8.035800E+00 0.0 0.0
 3.089600E-02 0.0 2.195300E+01 0.0 0.0
 6.127600E-01 0.0 7.769901E+01 0.0 0.0
 0.0 2.714800E+00 0.0 0.0 4.340800E+00 0.0 0.0 0.0

RECORD 100
 SIMPLE NUC.NO, OTHER NUC.NO, SIGMA IND, SCAT.IND, EXTRA 49 0 0 0 0
 NAME *****
 GENERAL DATA

0.0	0.0	0.0	0.0	0.0	0.0	0.0	0.0	0.0
0.0	0.0	0.0	0.0	0.0	0.0	0.0	0.0	0.0
0.0	0.0	0.0	0.0	0.0	0.0	0.0	0.0	0.0
0.0	0.0	0.0	0.0	0.0	0.0	0.0	0.0	0.0
0.0	0.0	0.0	0.0	0.0	0.0	0.0	0.0	0.0
0.0	0.0	0.0	0.0	0.0	0.0	0.0	0.0	0.0
0.0	0.0	0.0	0.0	0.0	0.0	0.0	0.0	0.0

RECORD 101
 (SIGA(K), SIGF(K), SIGTR(K), SNU(K), SIGX(K), K=1,KMAX)/((SIGS(KK,K),KK=1,KMAX),K=1,KMAX)
 3.860000E-03 0.0 8.033300E+00 0.0 0.0
 4.374900E-02 0.0 2.209000E+01 0.0 0.0
 6.127600E-01 0.0 7.769901E+01 0.0 0.0
 0.0 3.091000E+00 0.0 0.0 5.089900E+00 0.0 0.0 0.0

Information Processed Center

RECORD 102
 SIMPLE NUC.NO, OTHER NUC.NO, SIGMA IND, SCAT.IND, EXTRA 50 0 0 0 0
 NAME *****
 GENERAL DATA

0.0	0.0	0.0	0.0	0.0	0.0	0.0	0.0	0.0
0.0	0.0	0.0	0.0	0.0	0.0	0.0	0.0	0.0
0.0	0.0	0.0	0.0	0.0	0.0	0.0	0.0	0.0
0.0	0.0	0.0	0.0	0.0	0.0	0.0	0.0	0.0
0.0	0.0	0.0	0.0	0.0	0.0	0.0	0.0	0.0
0.0	0.0	0.0	0.0	0.0	0.0	0.0	0.0	0.0
0.0	0.0	0.0	0.0	0.0	0.0	0.0	0.0	0.0

RECORD 103
 (SIGA(K), SIGF(K), SIGTR(K), SNU(K), SIGX(K), K=1,KMAX)/((SIGS(KK,K),KK=1,KMAX),K=1,KMAX)
 3.050300E-03 0.0 2.008800E+00 0.0 0.0
 1.896600E-02 0.0 1.380300E+00 0.0 0.0
 2.645800E-01 0.0 1.559100E+00 0.0 0.0
 0.0 8.926202E-03 0.0 0.0 1.331800E-02 0.0 0.0 0.0

RECORD 104
 SIMPLE NUC.NO, OTHER NUC.NO, SIGMA IND, SCAT.IND, EXTRA 51 0 0 0 0
 NAME *****
 GENERAL DATA

0.0	0.0	0.0	0.0	0.0	0.0	0.0	0.0	0.0
0.0	0.0	0.0	0.0	0.0	0.0	0.0	0.0	0.0
0.0	0.0	0.0	0.0	0.0	0.0	0.0	0.0	0.0
0.0	0.0	0.0	0.0	0.0	0.0	0.0	0.0	0.0
0.0	0.0	0.0	0.0	0.0	0.0	0.0	0.0	0.0
0.0	0.0	0.0	0.0	0.0	0.0	0.0	0.0	0.0
0.0	0.0	0.0	0.0	0.0	0.0	0.0	0.0	0.0

0.0	0.0	0.0	0.0	0.0	0.0	0.0	0.0	0.0	0.0
0.0	0.0	0.0	0.0	0.0	0.0	0.0	0.0	0.0	0.0

RECORD105

(SIGA(K), SIGF(K), SIGTR(K), SNU(K), SIGX(K), K=1,KMAX)/((SIGS(KK,K),KK=1,KMAX),K=1,KMAX)

3.809700E-03	0.0	7.485600E+00	0.0	0.0	0.0	0.0	0.0	0.0	0.0
3.868700E-02	0.0	2.195900E+01	0.0	0.0	0.0	0.0	0.0	0.0	0.0
6.127600E-01	0.0	7.769901E+01	0.0	0.0	0.0	4.326500E+00	0.0	0.0	0.0
0.0	2.373100E+00	0.0	0.0	0.0	0.0	0.0	0.0	0.0	0.0

RECORD106

SIMPLE NUC.NO, OTHER NUC.NO, SIGMA INC, SCAT.IND, EXTRA 52 0 0 0 0

NAME *****

GENERAL DATA

0.0	0.0	0.0	0.0	0.0	0.0	0.0	0.0	0.0	0.0
0.0	0.0	0.0	0.0	0.0	0.0	0.0	0.0	0.0	0.0
0.0	0.0	0.0	0.0	0.0	0.0	0.0	0.0	0.0	0.0
0.0	0.0	0.0	0.0	0.0	0.0	0.0	0.0	0.0	0.0
0.0	0.0	0.0	0.0	0.0	0.0	0.0	0.0	0.0	0.0
0.0	0.0	0.0	0.0	0.0	0.0	0.0	0.0	0.0	0.0
0.0	0.0	0.0	0.0	0.0	0.0	0.0	0.0	0.0	0.0

RECORD107

(SIGA(K), SIGF(K), SIGTR(K), SNU(K), SIGX(K), K=1,KMAX)/((SIGS(KK,K),KK=1,KMAX),K=1,KMAX)

2.905400E-03	0.0	2.068200E+00	0.0	0.0	0.0	0.0	0.0	0.0	0.0
1.345500E-02	0.0	1.378200E+00	0.0	0.0	0.0	0.0	0.0	0.0	0.0
2.116600E-01	0.0	1.599100E+00	0.0	0.0	0.0	0.0	0.0	0.0	0.0
0.0	6.788878E-03	0.0	0.0	0.0	0.0	1.103000E-02	0.0	0.0	0.0

RECORD108

SIMPLE NUC.NO, OTHER NUC.NO, SIGMA IND, SCAT.IND, EXTRA 53 0 0 0 0

NAME *****

GENERAL DATA

0.0	0.0	0.0	0.0	0.0	0.0	0.0	0.0	0.0	0.0
0.0	0.0	0.0	0.0	0.0	0.0	0.0	0.0	0.0	0.0
0.0	0.0	0.0	0.0	0.0	0.0	0.0	0.0	0.0	0.0
0.0	0.0	0.0	0.0	0.0	0.0	0.0	0.0	0.0	0.0
0.0	0.0	0.0	0.0	0.0	0.0	0.0	0.0	0.0	0.0
0.0	0.0	0.0	0.0	0.0	0.0	0.0	0.0	0.0	0.0
0.0	0.0	0.0	0.0	0.0	0.0	0.0	0.0	0.0	0.0

RECORD109

(SIGA(K), SIGF(K), SIGTR(K), SNU(K), SIGX(K), K=1,KMAX)/((SIGS(KK,K),KK=1,KMAX),K=1,KMAX)

3.284900E-03	0.0	2.075600E+00	0.0	0.0	0.0	0.0	0.0	0.0	0.0
1.485600E-02	0.0	1.377600E+00	0.0	0.0	0.0	0.0	0.0	0.0	0.0
2.434100E-01	0.0	1.599100E+00	0.0	0.0	0.0	0.0	0.0	0.0	0.0
0.0	6.632902E-03	0.0	0.0	0.0	0.0	1.002100E-02	0.0	0.0	0.0

RECORD110

SIMPLE NUC.NO, OTHER NUC.NO, SIGMA INC, SCAT.IND, EXTRA 54 0 0 0 0

NAME *****

GENERAL DATA

0.0	0.0	0.0	0.0	0.0	0.0	0.0	0.0	0.0	0.0
0.0	0.0	0.0	0.0	0.0	0.0	0.0	0.0	0.0	0.0
0.0	0.0	0.0	0.0	0.0	0.0	0.0	0.0	0.0	0.0
0.0	0.0	0.0	0.0	0.0	0.0	0.0	0.0	0.0	0.0
0.0	0.0	0.0	0.0	0.0	0.0	0.0	0.0	0.0	0.0
0.0	0.0	0.0	0.0	0.0	0.0	0.0	0.0	0.0	0.0
0.0	0.0	0.0	0.0	0.0	0.0	0.0	0.0	0.0	0.0

RECORD111

(SIGA(K), SIGF(K), SIGTR(K), SNU(K), SIGX(K), K=1,KMAX)/((SIGS(KK,K),KK=1,KMAX),K=1,KMAX)

3.654600E-03	0.0	2.037500E+00	0.0	0.0	0.0	0.0	0.0	0.0	0.0
1.709600E-02	0.0	1.378200E+00	0.0	0.0	0.0	0.0	0.0	0.0	0.0
2.645800E-01	0.0	1.599100E+00	0.0	0.0	0.0	0.0	0.0	0.0	0.0
0.0	8.209400E-03	0.0	0.0	0.0	0.0	1.127200E-02	0.0	0.0	0.0

Information Processing Center

Information Processing Center

RECORD112
 SIMPLE NUC.NO, OTHER NUC.NO, SIGMA IND, SCAT.IND, EXTRA 55 0 0 0 0
 NAME *****

GENERAL DATA

0.0	0.0	0.0	0.0	0.0	0.0	0.0	0.0	0.0	0.0
0.0	0.0	0.0	0.0	0.0	0.0	0.0	0.0	0.0	0.0
0.0	0.0	0.0	0.0	0.0	0.0	0.0	0.0	0.0	0.0
0.0	0.0	0.0	0.0	0.0	0.0	0.0	0.0	0.0	0.0
0.0	0.0	0.0	0.0	0.0	0.0	0.0	0.0	0.0	0.0
0.0	0.0	0.0	0.0	0.0	0.0	0.0	0.0	0.0	0.0
0.0	0.0	0.0	0.0	0.0	0.0	0.0	0.0	0.0	0.0
0.0	0.0	0.0	0.0	0.0	0.0	0.0	0.0	0.0	0.0

Information Processing Center

RECORD113
 (SIGA(K), SIGF(K), SIGTR(K), SNU(K), SIGX(K), K=1,KMAX)/((SIGS(KK,K),KK=1,KMAX),K=1,KMAX)
 3.043170E-03 0.0 4.86230CE+00 0.0 0.0
 1.223700E-04 0.0 5.534510E+00 0.0 0.0
 2.464010E-03 0.0 7.837680E+00 0.0 0.0
 0.0 7.297190E-01 0.0 0.0 6.795890E-01 0.0 0.0 0.0

RECORD114
 SIMPLE NUC.NO, OTHER NUC.NO, SIGMA IND, SCAT.IND, EXTRA 56 0 0 0 0
 NAME *****

GENERAL DATA

0.0	0.0	0.0	0.0	0.0	0.0	0.0	0.0	0.0	0.0
0.0	0.0	0.0	0.0	0.0	0.0	0.0	0.0	0.0	0.0
0.0	0.0	0.0	0.0	0.0	0.0	0.0	0.0	0.0	0.0
0.0	0.0	0.0	0.0	0.0	0.0	0.0	0.0	0.0	0.0
0.0	0.0	0.0	0.0	0.0	0.0	0.0	0.0	0.0	0.0
0.0	0.0	0.0	0.0	0.0	0.0	0.0	0.0	0.0	0.0
0.0	0.0	0.0	0.0	0.0	0.0	0.0	0.0	0.0	0.0
0.0	0.0	0.0	0.0	0.0	0.0	0.0	0.0	0.0	0.0

RECORD115
 (SIGA(K), SIGF(K), SIGTR(K), SNU(K), SIGX(K), K=1,KMAX)/((SIGS(KK,K),KK=1,KMAX),K=1,KMAX)
 0.0 0.0 4.23800E-02 0.0 0.0
 0.0 0.0 4.340300E-02 0.0 0.0
 0.0 0.0 4.555650E-02 0.0 0.0
 0.0 0.0 0.0 0.0 0.0 0.0 0.0 0.0

RECORD116
 SIMPLE NUC.NO, OTHER NUC.NO, SIGMA IND, SCAT.IND, EXTRA 57 0 0 0 0
 NAME *****VOID

GENERAL DATA

0.0	0.0	0.0	0.0	0.0	0.0	0.0	0.0	0.0	0.0
0.0	0.0	0.0	0.0	0.0	0.0	0.0	0.0	0.0	0.0
0.0	0.0	0.0	0.0	0.0	0.0	0.0	0.0	0.0	0.0
0.0	0.0	0.0	0.0	0.0	0.0	0.0	0.0	0.0	0.0
0.0	0.0	0.0	0.0	0.0	0.0	0.0	0.0	0.0	0.0
0.0	0.0	0.0	0.0	0.0	0.0	0.0	0.0	0.0	0.0
0.0	0.0	0.0	0.0	0.0	0.0	0.0	0.0	0.0	0.0
0.0	0.0	0.0	0.0	0.0	0.0	0.0	0.0	0.0	0.0

Information Processing Center

RECORD117
 (SIGA(K), SIGF(K), SIGTR(K), SNU(K), SIGX(K), K=1,KMAX)/((SIGS(KK,K),KK=1,KMAX),K=1,KMAX)
 0.0 0.0 1.221000E-01 0.0 0.0
 0.0 0.0 1.739000E-01 0.0 0.0
 0.0 0.0 2.104000E-01 0.0 0.0
 0.0 0.0 0.0 0.0 0.0 0.0 0.0 0.0

RECORD118
 SIMPLF NUC.NO, OTHER NUC.NO, SIGMA IND, SCAT.IND, EXTRA 58 0 0 0 0
 NAME ***** BE

GENERAL DATA

0.0	0.0	0.0	0.0	0.0	0.0	0.0	0.0	0.0	0.0
0.0	0.0	0.0	0.0	0.0	0.0	0.0	0.0	0.0	0.0
0.0	0.0	0.0	0.0	0.0	0.0	0.0	0.0	0.0	0.0
0.0	0.0	0.0	0.0	0.0	0.0	0.0	0.0	0.0	0.0

0.0	0.0	0.0	0.0	0.0	0.0	0.0	0.0	0.0	0.0
RECORD126									
SIMPLE NUC.NO, OTHER NUC.NO, SIGMA INC, SCAT. IND, EXTRA 62 0 0 0 0									
NAME *****B-SS									
GENERAL DATA									
0.0	0.0	0.0	0.0	0.0	0.0	0.0	0.0	0.0	0.0
0.0	0.0	0.0	0.0	0.0	0.0	0.0	0.0	0.0	0.0
0.0	0.0	0.0	0.0	0.0	0.0	0.0	0.0	0.0	0.0
0.0	0.0	0.0	0.0	0.0	0.0	0.0	0.0	0.0	0.0
0.0	0.0	0.0	0.0	0.0	0.0	0.0	0.0	0.0	0.0
0.0	0.0	0.0	0.0	0.0	0.0	0.0	0.0	0.0	0.0
0.0	0.0	0.0	0.0	0.0	0.0	0.0	0.0	0.0	0.0
RECORD127									
(SIGA(K), SIGF(K), SIGTR(K), SNU(K), SIGX(K), K=1,KMAX)/((SIGS(KK,K),KK=1,KMAX),K=1,KMAX)									
3.004230E+00	0.0	3.180100E+02	0.0	0.0	0.0	0.0	0.0	0.0	0.0
1.646170E+02	0.0	1.174430E+03	0.0	0.0	0.0	0.0	0.0	0.0	0.0
3.083700E+03	0.0	7.770898E+02	0.0	0.0	0.0	0.0	0.0	0.0	0.0
0.0	2.350190E+00	0.0	0.0	0.0	1.853550E+00	0.0	0.0	0.0	0.0
RECORD128									
SIMPLE NUC.NO, OTHER NUC.NO, SIGMA INC, SCAT. IND, EXTRA 63 0 0 0 0									
NAME *****STEEL									
GENERAL DATA									
0.0	0.0	0.0	0.0	0.0	0.0	0.0	0.0	0.0	0.0
0.0	0.0	0.0	0.0	0.0	0.0	0.0	0.0	0.0	0.0
0.0	0.0	0.0	0.0	0.0	0.0	0.0	0.0	0.0	0.0
0.0	0.0	0.0	0.0	0.0	0.0	0.0	0.0	0.0	0.0
0.0	0.0	0.0	0.0	0.0	0.0	0.0	0.0	0.0	0.0
0.0	0.0	0.0	0.0	0.0	0.0	0.0	0.0	0.0	0.0
0.0	0.0	0.0	0.0	0.0	0.0	0.0	0.0	0.0	0.0
RECORD129									
(SIGA(K), SIGF(K), SIGTR(K), SNU(K), SIGX(K), K=1,KMAX)/((SIGS(KK,K),KK=1,KMAX),K=1,KMAX)									
1.031000E-02	0.0	3.449210E+00	0.0	0.0	0.0	0.0	0.0	0.0	0.0
2.053400E-01	0.0	1.214910E+01	0.0	0.0	0.0	0.0	0.0	0.0	0.0
1.464630E+00	0.0	1.282220E+01	0.0	0.0	0.0	0.0	0.0	0.0	0.0
0.0	1.547000E-02	0.0	0.0	0.0	3.297000E-02	0.0	0.0	0.0	0.0
RECORD130									
SIMPLE NUC.NO, OTHER NUC.NO, SIGMA INC, SCAT. IND, EXTRA 64 0 0 0 0									
NAME *****CD(NEW)-HEX									
GENERAL DATA									
0.0	0.0	0.0	0.0	0.0	0.0	0.0	0.0	0.0	0.0
0.0	0.0	0.0	0.0	0.0	0.0	0.0	0.0	0.0	0.0
0.0	0.0	0.0	0.0	0.0	0.0	0.0	0.0	0.0	0.0
0.0	0.0	0.0	0.0	0.0	0.0	0.0	0.0	0.0	0.0
0.0	0.0	0.0	0.0	0.0	0.0	0.0	0.0	0.0	0.0
0.0	0.0	0.0	0.0	0.0	0.0	0.0	0.0	0.0	0.0
0.0	0.0	0.0	0.0	0.0	0.0	0.0	0.0	0.0	0.0
RECORD131									
(SIGA(K), SIGF(K), SIGTR(K), SNU(K), SIGX(K), K=1,KMAX)/((SIGS(KK,K),KK=1,KMAX),K=1,KMAX)									
3.827900E-01	0.0	1.919162E+01	0.0	0.0	0.0	0.0	0.0	0.0	0.0
2.077051E+01	0.0	2.743140E+01	0.0	0.0	0.0	0.0	0.0	0.0	0.0
3.668020E+03	0.0	5.132900E+02	0.0	0.0	0.0	0.0	0.0	0.0	0.0
0.0	0.0	0.0	0.0	0.0	0.0	0.0	0.0	0.0	0.0
RECORD132									
SIMPLE NUC.NO, OTHER NUC.NO, SIGMA INC, SCAT. IND, EXTRA 65 0 0 0 0									
NAME *****CD(NEW)-RAD									
GENERAL DATA									
0.0	0.0	0.0	0.0	0.0	0.0	0.0	0.0	0.0	0.0
0.0	0.0	0.0	0.0	0.0	0.0	0.0	0.0	0.0	0.0
0.0	0.0	0.0	0.0	0.0	0.0	0.0	0.0	0.0	0.0

Information Processing Center

Information Processing Center

0.0	0.0	0.0	0.0	0.0	0.0	0.0	0.0	0.0
0.0	0.0	0.0	0.0	0.0	0.0	0.0	0.0	0.0
0.0	0.0	0.0	0.0	0.0	0.0	0.0	0.0	0.0
0.0	0.0	0.0	0.0	0.0	0.0	0.0	0.0	0.0

RECORD133

(SIGA(K), SIGF(K), SIGTR(K), SNU(K), SIGX(K), K=1,KMAX)/((SIGS(KK,K),KK=1,KMAX),K=1,KMAX)								
4.323700E-01	0.0	2.135609E+01	0.0	0.0				
2.349080E+01	0.0	1.079250E+01	0.0	0.0				
7.202680E+03	0.0	2.621980E+02	0.0	0.0				
0.0	0.0	0.0	0.0	0.0	0.0	0.0	0.0	0.0

RECORD134

SIMPLE NUC.NO, OTHER NUC.NO, SIGMA IND, SCAT.IND, EXTRA 66 0 0 0 0

NAME ***** CD(NEW)-BLADE

GENERAL DATA

0.0	0.0	0.0	0.0	0.0	0.0	0.0	0.0	0.0
0.0	0.0	0.0	0.0	0.0	0.0	0.0	0.0	0.0
0.0	0.0	0.0	0.0	0.0	0.0	0.0	0.0	0.0
0.0	0.0	0.0	0.0	0.0	0.0	0.0	0.0	0.0
0.0	0.0	0.0	0.0	0.0	0.0	0.0	0.0	0.0
0.0	0.0	0.0	0.0	0.0	0.0	0.0	0.0	0.0

RECORD135

(SIGA(K), SIGF(K), SIGTR(K), SNU(K), SIGX(K), K=1,KMAX)/((SIGS(KK,K),KK=1,KMAX),K=1,KMAX)								
1.934000E-01	0.0	8.777200E+00	0.0	0.0				
1.100410E+01	0.0	1.299220E+01	0.0	0.0				
5.544857E+04	0.0	2.790701E+02	0.0	0.0				
0.0	6.999999E-03	0.0	0.0	0.0	0.0	0.0	0.0	0.0

LAST RECORD NO.136 CONTAINS INTEGER -1

*****CITATION - SECTION 2 (JULY 1971) - SUPPLEMENT 3 (JULY 1972)*****

*****THIS JOB WAS RUN ON 9/05/76 ON THE IBM 370/165*****

MOLY SAMPLE HOLDER, NP FIXED AT 12", B-SS BLADES AT 9", 24 ELEMENTS

GENERAL CONTROL INPUT - SECTION 001

0	0	1	0	0	0	0	0	0	0	0	0	0	0	0	0	0	0	0	0	0	0	0	6	0	0	0
1	0	0	1	0	0	0	0	1	1	0	0	0	1	0	0	0	0	0	0	0	0	0	0	0	0	0
200	100	10	2	3	0	0	0	0	0	0	0	0	0	0	0	0	0	20	60	20	60	60	240			
1.200000E+00	9.000000E-01	9.999999E+09	9.999999E+23	0.0				1.000000E+00																		

NEUTRON FLUX PROBLEM DESCRIPTION - SECTION 003

0	0	0	0	12	0	0	0	0	0	1	1	1	0	0	0	0	0	0	0	0	0	0	0	0	0
9.999999E-04	1.000000E-02	9.999999E-05	9.999999E-05	9.999999E-05	0.0																				
0.0	-3.000000E+00	5.000000E+00	1.000000E+00	5.000000E-01	0.0																				

LEFT, TOP, RIGHT, BOTTOM, FRONT, BACK BOUNDARY CONDITIONS ARE

0.0	0.0	0.0	4.692000E-01	4.692000E-01	4.692000E-01
-----	-----	-----	--------------	--------------	--------------

THREE DIMENSIONAL CYLINDRICAL GEOMETRY (R, THETA, Z) WIDTH 3.141590E+00 HEIGHT 1.244000E+02 DEPTH 1.640000E+02

REGION SPECIFICATIONS

PTS	REGION WIDTH						
1	4.632500E-02	1	6.069999E-03	1	6.457370E-01	1	2.966700E-01
1	6.457370E-01	1	1.047900E-01	1	6.457370E-01	1	2.966700E-01
1	5.239500E-02						
PTS	REGION HEIGHT						
1	3.552000E+00	1	9.747000E-01	1	1.814300E+00	1	6.340000E-01
1	4.282000E+00	1	1.000000E+00	1	9.525000E-01	1	4.465000E-01
1	6.335000E-01						
1	6.350000E-01	1	6.870000E-01	1	1.726000E+00	1	1.543500E+01
1	3.000000E+00						
1	6.503999E+01						
PTS	REGION DEPTH						
1	3.048000E+01	1	1.016000E+01	1	1.265000E+01	1	7.570000E+00
1	5.080000E+00	1	5.002500E+00	1	1.000500E+01	1	2.695000E+00
1	1.300000E+00						
1	1.900000E+00	1	1.900000E+00	1	3.200000E+00	1	6.000000E-01
1	4.127500E+00	1	4.251750E+01				

X-DIR. POINTS 11 Y-DIR. POINTS 19 Z-DIR. POINTS 20

DISTANCES TO MESH INTERVAL INTERFACES

J	DIST.																
2	0.046	3	0.052	4	0.698	5	0.995	6	1.100	7	1.396	8	2.042	9	2.147	10	2.793
11	3.089	12	3.142														

I DIST.

Information Processing Center

Information Processing Center

Information Processing Center

Information Processing Center

2	3.552	3	4.527	4	6.341	5	6.975	6	8.725	7	14.175	8	18.457	9	19.457	10	20.409
11	20.856	12	21.489	13	22.124	14	23.077	15	23.764	16	25.490	17	40.925	18	56.360	19	59.360
20	124.400																

KB	DIST																
2	30.460	3	40.640	4	53.290	5	60.860	6	71.020	7	76.100	8	81.102	9	86.105	10	96.110
11	98.805	12	101.500	13	102.800	14	103.400	15	105.300	16	108.500	17	109.100	18	113.227	19	117.355
20	121.482	21	164.000														

DISTANCES TO FLUX POINTS

J	DIST.																
1	0.023	2	0.049	3	0.375	4	0.846	5	1.047	6	1.248	7	1.719	8	2.094	9	2.470
10	2.941	11	3.115														
I	DIST.																
1	2.512	2	4.069	3	5.509	4	6.666	5	7.899	6	11.770	7	16.456	8	18.964	9	19.939
10	20.634	11	21.175	12	21.809	13	22.606	14	23.423	15	24.642	16	34.092	17	49.251	18	57.879
19	97.465																
KB	DIST																
1	15.240	2	35.560	3	46.965	4	57.075	5	65.940	6	73.560	7	78.601	8	83.604	9	91.107
10	97.457	11	100.152	12	102.150	13	103.100	14	104.350	15	106.900	16	108.800	17	111.164	18	115.291
19	119.419	20	142.741														

ZONE INPUT BY REGION

PLANE NUMBER 1																	
18	18	18	18	18	18	18	18	18	18	18	18	18	18	18	18	18	18
18	18	18	18	18	18	18	18	18	18	18	18	18	18	18	18	18	18
18	18	18	18	18	18	18	18	18	18	18	18	18	18	18	18	18	18
18	18	18	18	18	18	18	18	18	18	18	18	18	18	18	18	18	18
18	18	18	18	18	18	18	18	18	18	18	18	18	18	18	18	18	18
18	18	18	18	18	18	18	18	18	18	18	18	18	18	18	18	18	18
18	18	18	18	18	18	18	18	18	18	18	18	18	18	18	18	18	18
18	18	18	18	18	18	18	18	18	18	18	18	18	18	18	18	18	18
47	47	18	18	18	18	18	18	18	18	18	18	18	18	18	18	18	18
18	47	18	18	18	18	18	18	18	18	18	18	18	18	18	18	18	18
47	47	46	46	18	46	46	18	46	46	18	46	46	18	46	46	18	46
18	18	18	18	18	18	18	18	18	18	18	18	18	18	18	18	18	18
18	18	18	18	18	18	18	18	18	18	18	18	18	18	18	18	18	18
18	18	18	18	18	18	18	18	18	18	18	18	18	18	18	18	18	18
18	18	18	18	18	18	18	18	18	18	18	18	18	18	18	18	18	18
18	18	18	18	18	18	18	18	18	18	18	18	18	18	18	18	18	18
15	15	15	15	15	15	15	15	15	15	15	15	15	15	15	15	15	15
16	16	16	16	16	16	16	16	16	16	16	16	16	16	16	16	16	16
PLANE NUMBER 2																	
2	2	2	2	2	2	2	2	2	2	2	2	2	2	2	2	2	2
2	2	2	2	2	2	2	2	2	2	2	2	2	2	2	2	2	2
2	2	2	2	2	2	2	2	2	2	2	2	2	2	2	2	2	2
2	2	2	2	2	2	2	2	2	2	2	2	2	2	2	2	2	2
2	2	2	2	2	2	2	2	2	2	2	2	2	2	2	2	2	2
2	2	2	2	2	2	2	2	2	2	2	2	2	2	2	2	2	2
2	2	2	2	2	2	2	2	2	2	2	2	2	2	2	2	2	2
2	2	2	2	2	2	2	2	2	2	2	2	2	2	2	2	2	2
47	47	2	2	2	2	2	2	2	2	2	2	2	2	2	2	2	2
2	47	2	2	2	2	2	2	2	2	2	2	2	2	2	2	2	2
47	47	46	46	2	46	46	2	46	46	2	46	46	2	46	46	2	46
2	2	2	2	2	2	2	2	2	2	2	2	2	2	2	2	2	2
2	2	2	2	2	2	2	2	2	2	2	2	2	2	2	2	2	2
2	2	2	2	2	2	2	2	2	2	2	2	2	2	2	2	2	2

Information Processing Center

Information Processing Center

Information Processing Center

Information Processing Center

2	2	2	2	2	2	2	2	2	2	2
19	19	19	19	19	19	19	19	19	19	19
15	15	15	15	15	15	15	15	15	15	15
16	16	16	16	16	16	16	16	16	16	16

PLANE NUMBER 3

11	11	11	11	11	13	13	13	13	13	13
20	20	20	20	11	13	13	13	13	13	13
11	11	11	11	13	13	13	13	13	13	13
11	11	44	44	11	44	44	11	44	44	11
11	11	14	14	14	14	14	11	14	14	14
45	45	14	11	11	11	14	45	14	14	14
45	45	14	14	14	14	14	45	14	14	14
45	45	14	14	14	14	14	45	14	14	14
45	45	11	11	11	11	11	45	11	11	11
47	47	11	11	20	11	11	20	11	11	20
20	47	11	11	20	11	11	20	11	11	20
47	47	46	46	20	46	46	20	46	46	20
11	11	21	21	11	21	21	11	21	21	11
11	11	11	11	11	11	11	11	11	11	11
7	7	7	7	7	7	7	7	7	7	7
7	7	7	7	7	7	7	7	7	7	7
7	7	7	7	7	7	7	7	7	7	7
15	15	15	15	15	15	15	15	15	15	15
16	16	16	16	16	16	16	16	16	16	16

PLANE NUMBER 4

11	11	11	11	11	13	13	13	13	13	13
20	20	20	20	11	13	13	13	13	13	13
11	11	11	11	13	13	13	13	13	13	13
11	11	44	44	11	44	44	11	44	44	11
11	11	14	14	14	14	14	11	14	14	14
45	45	14	11	11	11	14	45	14	14	14
45	45	14	14	14	14	14	45	14	14	14
45	45	14	14	14	14	14	45	14	14	14
45	45	11	11	11	11	11	45	11	11	11
47	47	11	11	20	11	11	20	11	11	20
20	47	11	11	20	11	11	20	11	11	20
47	47	46	46	20	46	46	20	46	46	20
11	11	21	21	11	21	21	11	21	21	11
11	11	11	11	11	11	11	11	11	11	11
7	7	7	7	7	7	7	7	7	7	7
7	7	7	7	7	7	7	7	7	7	7
7	7	7	7	7	7	7	7	7	7	7
15	15	15	15	15	15	15	15	15	15	15
16	16	16	16	16	16	16	16	16	16	16

PLANE NUMBER 5

11	11	11	11	11	13	13	13	13	13	13
20	20	20	20	11	13	13	13	13	13	13
11	11	11	11	13	13	13	13	13	13	13
11	11	44	44	11	44	44	11	44	44	11
11	11	14	14	14	14	14	11	14	14	14
45	45	14	11	11	11	14	45	14	14	14
45	45	14	14	14	14	14	45	14	14	14
45	45	14	14	14	14	14	45	14	14	14
45	45	11	11	11	11	11	45	11	11	11
47	47	11	11	20	11	11	20	11	11	20
20	47	11	11	20	11	11	20	11	11	20
47	47	46	46	20	46	46	20	46	46	20
11	11	21	21	11	21	21	11	21	21	11
11	11	11	11	11	11	11	11	11	11	11
7	7	7	7	7	7	7	7	7	7	7
7	7	7	7	7	7	7	7	7	7	7
7	7	7	7	7	7	7	7	7	7	7
15	15	15	15	15	15	15	15	15	15	15

Information Processing Center

Information Processing Center

Information Processing Center

Information Processing Center

16 16 16 16 16 16 16 16 16 16 16

PLANE NUMBER 6

11	11	11	11	11	4	4	4	4	4	4
20	20	20	20	11	4	4	4	4	4	4
11	11	11	11	4	4	4	4	4	4	4
10	10	10	10	10	10	10	10	10	10	10
10	10	5	5	5	5	5	10	5	5	5
10	10	5	11	11	11	5	10	5	5	5
10	10	5	5	5	5	5	10	5	5	5
11	11	6	6	6	6	6	11	6	6	6
11	11	11	11	11	11	11	11	11	11	11
47	47	11	11	20	11	11	20	11	11	20
20	47	11	11	20	11	11	20	11	11	20
47	47	46	46	20	46	46	20	46	46	20
11	11	21	21	11	21	21	11	21	21	11
11	11	11	11	11	11	11	11	11	11	11
7	7	7	7	7	7	7	7	7	7	7
7	7	7	7	7	7	7	7	7	7	7
7	7	7	7	7	7	7	7	7	7	7
15	15	15	15	15	15	15	15	15	15	15
16	16	16	16	16	16	16	16	16	16	16

Information Processing Center

Information Processing Center

PLANE NUMBER 7

11	11	11	11	11	4	4	4	4	4	4
20	20	20	20	11	4	4	4	4	4	4
11	11	11	11	4	4	4	4	4	4	4
10	10	10	10	10	10	10	10	10	10	10
10	10	5	5	5	5	5	10	5	5	5
10	10	5	11	11	11	5	10	5	5	5
10	10	5	5	5	5	5	10	5	5	5
11	11	6	6	6	6	6	11	6	6	6
11	11	11	11	11	11	11	11	11	11	11
47	47	11	11	20	11	11	20	11	11	20
20	47	11	11	20	11	11	20	11	11	20
47	47	46	46	20	46	46	20	46	46	20
11	11	21	21	11	21	21	11	21	21	11
11	11	11	11	11	11	11	11	11	11	11
7	7	7	7	7	7	7	7	7	7	7
7	7	7	7	7	7	7	7	7	7	7
7	7	7	7	7	7	7	7	7	7	7
15	15	15	15	15	15	15	15	15	15	15
16	16	16	16	16	16	16	16	16	16	16

Information Processing Center

Information Processing Center

PLANE NUMBER 8

11	11	11	11	11	4	4	4	4	4	4
20	20	20	20	11	4	4	4	4	4	4
11	11	11	11	4	4	4	4	4	4	4
10	10	10	10	10	10	10	10	10	10	10
10	10	5	5	5	5	5	10	5	5	5
10	10	5	11	11	11	5	10	5	5	5
10	10	5	5	5	5	5	10	5	5	5
11	11	6	6	6	6	6	11	6	6	6
11	11	11	11	11	11	11	11	11	11	11
20	20	11	11	20	11	11	20	11	11	20
20	20	11	11	20	11	11	20	11	11	20
20	20	21	21	20	21	21	20	21	21	20
11	11	21	21	11	21	21	11	21	21	11
11	11	11	11	11	11	11	11	11	11	11
7	7	7	7	7	7	7	7	7	7	7
7	7	7	7	7	7	7	7	7	7	7
7	7	7	7	7	7	7	7	7	7	7
15	15	15	15	15	15	15	15	15	15	15
16	16	16	16	16	16	16	16	16	16	16

PLANE NUMBER 9

11	11	11	11	11	4	4	4	4	4	4
20	20	20	20	11	4	4	4	4	4	4
11	11	11	11	4	4	4	4	4	4	4
10	10	10	10	10	10	10	10	10	10	10
10	10	5	5	5	5	5	10	5	5	5
10	10	5	11	11	11	5	10	5	5	5
10	10	5	5	5	5	5	10	5	5	5
11	11	6	6	6	6	6	11	6	6	6
11	11	11	11	11	11	11	11	11	11	11
20	20	11	11	20	11	11	20	11	11	20
20	20	11	11	20	11	11	20	11	11	20
20	20	21	21	20	21	21	20	21	21	20
11	11	21	21	11	21	21	11	21	21	11
11	11	11	11	11	11	11	11	11	11	11
7	7	7	7	7	7	7	7	7	7	7
7	7	7	7	7	7	7	7	7	7	7
7	7	7	7	7	7	7	7	7	7	7
15	15	15	15	15	15	15	15	15	15	15
16	16	16	16	16	16	16	16	16	16	16

Information Processing Center

PLANE NUMBER 10										
11	11	11	11	11	3	3	3	3	3	3
20	20	20	20	11	3	3	3	3	3	3
11	11	11	11	3	3	3	3	3	3	3
10	10	10	10	10	10	10	10	10	10	10
10	10	5	5	5	5	5	10	5	5	5
10	10	5	11	11	11	5	10	5	5	5
10	10	5	5	5	5	5	10	5	5	5
11	11	1	1	1	1	1	11	1	1	1
11	11	11	11	11	11	11	11	11	11	11
20	20	11	11	20	11	11	20	11	11	20
20	20	11	11	20	11	11	20	11	11	20
20	20	21	21	20	21	21	20	21	21	20
11	11	21	21	11	21	21	11	21	21	11
11	11	11	11	11	11	11	11	11	11	11
7	7	7	7	7	7	7	7	7	7	7
7	7	7	7	7	7	7	7	7	7	7
7	7	7	7	7	7	7	7	7	7	7
15	15	15	15	15	15	15	15	15	15	15
16	16	16	16	16	16	16	16	16	16	16

Information Processing Center

PLANE NUMBER 11										
11	11	11	11	11	3	3	3	3	3	3
20	20	20	20	11	3	3	3	3	3	3
11	11	11	11	3	3	3	3	3	3	3
10	10	10	10	10	10	10	10	10	10	10
10	10	5	5	5	5	5	10	5	5	5
10	10	5	11	11	11	5	10	5	5	5
10	10	5	5	5	5	5	10	5	5	5
11	11	1	1	1	1	1	11	1	1	1
11	11	11	11	11	11	11	11	11	11	11
11	11	11	11	11	11	11	11	11	11	11
11	11	2	2	11	2	2	11	2	2	11
11	11	21	21	11	21	21	11	21	21	11
11	11	21	21	11	21	21	11	21	21	11
11	11	11	11	11	11	11	11	11	11	11
7	7	7	7	7	7	7	7	7	7	7
7	7	7	7	7	7	7	7	7	7	7
7	7	7	7	7	7	7	7	7	7	7
15	15	15	15	15	15	15	15	15	15	15
16	16	16	16	16	16	16	16	16	16	16

Information Processing Center

PLANE NUMBER 12										
2	2	2	2	2	2	2	2	2	2	2
20	20	20	20	2	2	2	2	2	2	2
2	2	2	2	2	2	2	2	2	2	2

Information Processing Center

Information Processing Center

10	10	10	10	10	10	10	10	10	10	10	10
2	2	2	2	2	2	2	2	2	2	2	2
2	2	2	2	2	2	2	2	2	2	2	2
2	2	2	2	2	2	2	2	2	2	2	2
2	2	2	2	2	2	2	2	2	2	2	2
11	11	11	11	11	11	11	11	11	11	11	11
11	11	11	11	11	11	11	11	11	11	11	11
11	11	2	2	11	2	2	11	2	2	11	11
11	11	21	21	11	21	21	11	21	21	11	11
11	11	21	21	11	21	21	11	21	21	11	11
11	11	11	11	11	11	11	11	11	11	11	11
7	7	7	7	7	7	7	7	7	7	7	7
7	7	7	7	7	7	7	7	7	7	7	7
7	7	7	7	7	7	7	7	7	7	7	7
15	15	15	15	15	15	15	15	15	15	15	15
16	16	16	16	16	16	16	16	16	16	16	16

PLANE NUMBER 13

24	24	24	24	24	24	24	24	24	24	24	24
24	24	24	24	24	24	24	24	24	24	24	24
24	24	24	24	24	24	24	24	24	24	24	24
10	10	10	10	10	10	10	10	10	10	10	10
24	24	24	24	24	24	24	24	24	24	24	24
24	24	24	24	24	24	24	24	24	24	24	24
24	24	24	24	24	24	24	24	24	24	24	24
24	24	24	24	24	24	24	24	24	24	24	24
24	24	24	24	24	24	24	24	24	24	24	24
11	11	11	11	11	11	11	11	11	11	11	11
11	11	11	11	11	11	11	11	11	11	11	11
11	11	2	2	11	2	2	11	2	2	11	11
11	11	21	21	11	21	21	11	21	21	11	11
11	11	11	11	11	11	11	11	11	11	11	11
7	7	7	7	7	7	7	7	7	7	7	7
7	7	7	7	7	7	7	7	7	7	7	7
7	7	7	7	7	7	7	7	7	7	7	7
15	15	15	15	15	15	15	15	15	15	15	15
16	16	16	16	16	16	16	16	16	16	16	16

PLANE NUMBER 14

2	2	2	2	2	2	2	2	2	2	2	2
2	2	2	2	2	2	2	2	2	2	2	2
2	2	2	2	2	2	2	2	2	2	2	2
10	10	10	10	10	10	10	10	10	10	10	10
2	2	2	2	2	2	2	2	2	2	2	2
2	2	2	2	2	2	2	2	2	2	2	2
2	2	2	2	2	2	2	2	2	2	2	2
2	2	2	2	2	2	2	2	2	2	2	2
20	20	20	20	20	20	20	20	20	20	20	20
2	2	2	2	2	2	2	2	2	2	2	2
2	2	2	2	2	2	2	2	2	2	2	2
21	21	21	21	21	21	21	21	21	21	21	21
11	11	11	11	11	11	11	11	11	11	11	11
11	11	11	11	11	11	11	11	11	11	11	11
7	7	7	7	7	7	7	7	7	7	7	7
7	7	7	7	7	7	7	7	7	7	7	7
7	7	7	7	7	7	7	7	7	7	7	7
15	15	15	15	15	15	15	15	15	15	15	15
16	16	16	16	16	16	16	16	16	16	16	16

PLANE NUMBER 15

17	17	17	17	17	17	17	17	17	17	17	17
17	17	17	17	17	17	17	17	17	17	17	17
17	17	17	17	17	17	17	17	17	17	17	17
10	10	10	10	10	10	10	10	10	10	10	10
17	17	17	17	17	17	17	17	17	17	17	17
17	17	17	17	17	17	17	17	17	17	17	17

Information Processing Center

Information Processing Center

Information Processing Center

Information Processing Center

2	2	2	2	2	2	2	2	2	2	2	2
2	2	2	2	2	2	2	2	2	2	2	2
2	2	2	2	2	2	2	2	2	2	2	2
2	2	2	2	2	2	2	2	2	2	2	2
7	7	7	7	7	7	7	7	7	7	7	7
7	7	7	7	7	7	7	7	7	7	7	7
7	7	7	7	7	7	7	7	7	7	7	7
7	7	7	7	7	7	7	7	7	7	7	7
7	7	7	7	7	7	7	7	7	7	7	7
7	7	7	7	7	7	7	7	7	7	7	7
7	7	7	7	7	7	7	7	7	7	7	7
15	15	15	15	15	15	15	15	15	15	15	15
16	16	16	16	16	16	16	16	16	16	16	16

Information Processing Center

PLANE NUMBER 16

7	7	20	20	20	20	20	7	20	20	20
7	7	20	20	20	20	20	7	20	20	20
20	20	20	20	20	20	20	20	20	20	20
20	20	20	20	20	20	20	20	20	20	20
20	20	20	20	20	20	20	20	20	20	20
20	20	20	20	20	20	20	20	20	20	20
20	20	20	20	20	20	20	20	20	20	20
17	17	17	17	17	17	17	17	17	17	17
7	7	7	7	7	7	7	7	7	7	7
7	7	7	7	7	7	7	7	7	7	7
7	7	7	7	7	7	7	7	7	7	7
7	7	7	7	7	7	7	7	7	7	7
7	7	7	7	7	7	7	7	7	7	7
7	7	7	7	7	7	7	7	7	7	7
7	7	7	7	7	7	7	7	7	7	7
15	15	15	15	15	15	15	15	15	15	15
16	16	16	16	16	16	16	16	16	16	16

Information Processing Center

PLANE NUMBER 17

7	7	7	7	7	7	7	7	7	7	7
7	7	7	7	7	7	7	7	7	7	7
7	7	7	7	7	7	7	7	7	7	7
7	7	7	7	7	7	7	7	7	7	7
7	7	7	7	25	25	25	25	26	26	25
7	7	7	7	25	25	25	25	26	26	25
7	7	7	7	27	27	27	27	26	26	25
7	7	7	7	27	27	27	27	26	26	25
7	7	7	7	27	29	29	27	28	28	25
7	7	7	7	27	29	29	27	28	28	25
7	7	7	7	27	29	29	27	28	28	25
7	7	7	7	27	29	29	27	28	28	25
7	7	7	7	27	29	29	27	28	28	25
7	7	7	7	27	29	29	27	28	28	25
7	7	7	7	29	30	30	29	30	30	25
7	7	7	7	27	31	31	7	26	26	29
15	15	15	15	27	31	31	7	26	26	29
16	16	16	16	16	32	32	16	32	32	32

Information Processing Center

PLANE NUMBER 18

7	7	7	7	7	7	7	7	7	7	7
7	7	7	7	7	7	7	7	7	7	7
7	7	7	7	7	7	7	7	7	7	7
7	7	7	7	7	7	7	7	7	7	7
7	7	7	7	25	25	25	25	26	26	25
7	7	7	7	25	25	25	25	26	26	25
7	7	7	7	27	27	27	27	26	26	25
7	7	7	7	27	27	27	27	26	26	25
7	7	7	7	27	27	27	27	26	26	25
7	7	7	7	27	29	29	27	28	28	25

Information Processing Center

Information Processing Center

7	7	7	7	27	29	29	27	28	28	25
7	7	7	7	27	29	29	27	28	28	25
7	7	7	7	27	29	29	27	28	28	25
7	7	7	7	27	29	29	27	28	28	25
7	7	7	7	27	29	29	27	28	28	25
7	7	7	7	29	30	30	29	30	30	25
7	7	7	7	27	31	31	7	26	26	29
15	15	15	15	27	31	31	15	26	26	29
16	16	16	16	16	32	32	16	32	32	32

PLANE NUMBER 19

7	7	7	7	7	7	7	7	7	7	7
7	7	7	7	7	7	7	7	7	7	7
7	7	7	7	7	7	7	7	7	7	7
7	7	7	7	7	7	7	7	7	7	7
7	7	7	7	7	7	7	7	7	7	7
7	7	7	7	7	7	7	7	7	7	7
7	7	7	7	7	7	7	7	7	7	7
7	7	7	7	7	7	7	7	7	7	7
7	7	7	7	7	7	7	7	7	7	7
7	7	7	7	7	7	7	7	7	7	7
7	7	7	7	7	7	7	7	7	7	7
7	7	7	7	7	7	7	7	7	7	7
7	7	7	7	7	7	7	7	7	7	7
7	7	7	7	7	7	7	7	7	7	7
7	7	7	7	7	7	7	7	7	7	7
7	7	7	7	7	7	7	7	7	7	7
7	7	7	7	7	7	7	7	7	7	7
7	7	7	7	7	7	7	7	7	7	7
7	7	7	7	7	7	7	7	7	7	7
15	15	15	15	15	15	15	15	15	15	15
16	16	16	16	16	16	16	16	16	16	16

PLANE NUMBER 20

7	7	7	7	7	7	7	7	7	7	7
7	7	7	7	7	7	7	7	7	7	7
7	7	7	7	7	7	7	7	7	7	7
7	7	7	7	7	7	7	7	7	7	7
7	7	7	7	7	7	7	7	7	7	7
7	7	7	7	7	7	7	7	7	7	7
7	7	7	7	7	7	7	7	7	7	7
7	7	7	7	7	7	7	7	7	7	7
7	7	7	7	7	7	7	7	7	7	7
7	7	7	7	7	7	7	7	7	7	7
7	7	7	7	7	7	7	7	7	7	7
7	7	7	7	7	7	7	7	7	7	7
7	7	7	7	7	7	7	7	7	7	7
7	7	7	7	7	7	7	7	7	7	7
7	7	7	7	7	7	7	7	7	7	7
7	7	7	7	7	7	7	7	7	7	7
7	7	7	7	7	7	7	7	7	7	7
7	7	7	7	7	7	7	7	7	7	7
7	7	7	7	7	7	7	7	7	7	7
15	15	15	15	15	15	15	15	15	15	15
16	16	16	16	16	16	16	16	16	16	16

ZONE NUMBER AT EACH MESH INTERVAL

SPECIFICATION FOR LAYER NUMBER 1

	1	2	3	4	5	6	7	8	9	10	11
1	18	18	18	18	18	18	18	18	18	18	18
2	18	18	18	18	18	18	18	18	18	18	18
3	18	18	18	18	18	18	18	18	18	18	18
4	18	18	18	18	18	18	18	18	18	18	18
5	18	18	18	18	18	18	18	18	18	18	18

Information Processing Center

Information Processing Center

Information Processing Center

Information Processing Center

6	18	18	18	18	18	18	18	18	18	18	18	18
7	18	18	18	18	18	18	18	18	18	18	18	18
8	18	18	18	18	18	18	18	18	18	18	18	18
9	18	18	18	18	18	18	18	18	18	18	18	18
10	47	47	18	18	18	18	18	18	18	18	18	18
11	18	47	18	18	18	18	18	18	18	18	18	18
12	47	47	46	46	18	46	46	18	46	46	18	18
13	18	18	18	18	18	18	18	18	18	18	18	18
14	18	18	18	18	18	18	18	18	18	18	18	18
15	18	18	18	18	18	18	18	18	18	18	18	18
16	18	18	18	18	18	18	18	18	18	18	18	18
17	18	18	18	18	18	18	18	18	18	18	18	18
18	15	15	15	15	15	15	15	15	15	15	15	15
19	16	16	16	16	16	16	16	16	16	16	16	16

Information Processing Center

Information Processing Center

SPECIFICATION FOR LAYER NUMBER 2

	1	2	3	4	5	6	7	8	9	10	11
1	2	2	2	2	2	2	2	2	2	2	2
2	2	2	2	2	2	2	2	2	2	2	2
3	2	2	2	2	2	2	2	2	2	2	2
4	2	2	2	2	2	2	2	2	2	2	2
5	2	2	2	2	2	2	2	2	2	2	2
6	2	2	2	2	2	2	2	2	2	2	2
7	2	2	2	2	2	2	2	2	2	2	2
8	2	2	2	2	2	2	2	2	2	2	2
9	2	2	2	2	2	2	2	2	2	2	2
10	47	47	2	2	2	2	2	2	2	2	2
11	2	47	2	2	2	2	2	2	2	2	2
12	47	47	46	46	2	46	46	2	46	46	2
13	2	2	2	2	2	2	2	2	2	2	2
14	2	2	2	2	2	2	2	2	2	2	2
15	2	2	2	2	2	2	2	2	2	2	2
16	2	2	2	2	2	2	2	2	2	2	2
17	19	19	19	19	19	19	19	19	19	19	19
18	15	15	15	15	15	15	15	15	15	15	15
19	16	16	16	16	16	16	16	16	16	16	16

Information Processing Center

Information Processing Center

SPECIFICATION FOR LAYER NUMBER 3

	1	2	3	4	5	6	7	8	9	10	11
1	11	11	11	11	11	13	13	13	13	13	13
2	20	20	20	20	11	13	13	13	13	13	13
3	11	11	11	11	13	13	13	13	13	13	13
4	11	11	44	44	11	44	44	11	44	44	11
5	11	11	14	14	14	14	14	11	14	14	14
6	45	45	14	11	11	11	14	45	14	14	14
7	45	45	14	14	14	14	14	45	14	14	14
8	45	45	14	14	14	14	14	45	14	14	14
9	45	45	11	11	11	11	11	45	11	11	11
10	47	47	11	11	20	11	11	20	11	11	20
11	20	47	11	11	20	11	11	20	11	11	20
12	47	47	46	46	20	46	46	20	46	46	20
13	11	11	21	21	11	21	21	11	21	21	11
14	11	11	11	11	11	11	11	11	11	11	11
15	7	7	7	7	7	7	7	7	7	7	7
16	7	7	7	7	7	7	7	7	7	7	7
17	7	7	7	7	7	7	7	7	7	7	7
18	15	15	15	15	15	15	15	15	15	15	15
19	16	16	16	16	16	16	16	16	16	16	16

SPECIFICATION FOR LAYER NUMBER 4

	1	2	3	4	5	6	7	8	9	10	11
1	11	11	11	11	11	13	13	13	13	13	13
2	20	20	20	20	11	13	13	13	13	13	13
3	11	11	11	11	13	13	13	13	13	13	13
4	11	11	44	44	11	44	44	11	44	44	11
5	11	11	14	14	14	14	14	11	14	14	14
6	45	45	14	11	11	11	14	45	14	14	14
7	45	45	14	14	14	14	14	45	14	14	14
8	45	45	14	14	14	14	14	45	14	14	14
9	45	45	11	11	11	11	11	45	11	11	11
10	47	47	11	11	20	11	11	20	11	11	20
11	20	47	11	11	20	11	11	20	11	11	20
12	47	47	46	46	20	46	46	20	46	46	20
13	11	11	21	21	11	21	21	11	21	21	11
14	11	11	11	11	11	11	11	11	11	11	11
15	7	7	7	7	7	7	7	7	7	7	7
16	7	7	7	7	7	7	7	7	7	7	7
17	7	7	7	7	7	7	7	7	7	7	7
18	15	15	15	15	15	15	15	15	15	15	15
19	16	16	16	16	16	16	16	16	16	16	16

Information Processing Center

Information Processing Center

SPECIFICATION FOR LAYER NUMBER 5

	1	2	3	4	5	6	7	8	9	10	11
1	11	11	11	11	11	13	13	13	13	13	13
2	20	20	20	20	11	13	13	13	13	13	13
3	11	11	11	11	13	13	13	13	13	13	13
4	11	11	44	44	11	44	44	11	44	44	11
5	11	11	14	14	14	14	14	11	14	14	14
6	45	45	14	11	11	11	14	45	14	14	14
7	45	45	14	14	14	14	14	45	14	14	14
8	45	45	14	14	14	14	14	45	14	14	14
9	45	45	11	11	11	11	11	45	11	11	11
10	47	47	11	11	20	11	11	20	11	11	20
11	20	47	11	11	20	11	11	20	11	11	20
12	47	47	46	46	20	46	46	20	46	46	20
13	11	11	21	21	11	21	21	11	21	21	11
14	11	11	11	11	11	11	11	11	11	11	11
15	7	7	7	7	7	7	7	7	7	7	7
16	7	7	7	7	7	7	7	7	7	7	7
17	7	7	7	7	7	7	7	7	7	7	7
18	15	15	15	15	15	15	15	15	15	15	15
19	16	16	16	16	16	16	16	16	16	16	16

Information Processing Center

Information Processing Center

SPECIFICATION FOR LAYER NUMBER 6

	1	2	3	4	5	6	7	8	9	10	11
1	11	11	11	11	11	4	4	4	4	4	4
2	20	20	20	20	11	4	4	4	4	4	4
3	11	11	11	11	4	4	4	4	4	4	4
4	10	10	10	10	10	10	10	10	10	10	10
5	10	10	5	5	5	5	5	10	5	5	5
6	10	10	5	11	11	11	5	10	5	5	5
7	10	10	5	5	5	5	5	10	5	5	5

8	11	11	6	6	6	6	6	11	6	6	6
9	11	11	11	11	11	11	11	11	11	11	11
10	47	47	11	11	20	11	11	20	11	11	20
11	20	47	11	11	20	11	11	20	11	11	20
12	47	47	46	46	20	46	46	20	46	46	20
13	11	11	21	21	11	21	21	11	21	21	11
14	11	11	11	11	11	11	11	11	11	11	11
15	7	7	7	7	7	7	7	7	7	7	7
16	7	7	7	7	7	7	7	7	7	7	7
17	7	7	7	7	7	7	7	7	7	7	7
18	15	15	15	15	15	15	15	15	15	15	15
19	16	16	16	16	16	16	16	16	16	16	16

Information Processing Center

Information Processing Center

SPECIFICATION FOR LAYER NUMBER 7

	1	2	3	4	5	6	7	8	9	10	11
1	11	11	11	11	11	4	4	4	4	4	4
2	20	20	20	20	11	4	4	4	4	4	4
3	11	11	11	11	4	4	4	4	4	4	4
4	10	10	10	10	10	10	10	10	10	10	10
5	10	10	5	5	5	5	5	10	5	5	5
6	10	10	5	11	11	11	5	10	5	5	5
7	10	10	5	5	5	5	5	10	5	5	5
8	11	11	6	6	6	6	6	11	6	6	6
9	11	11	11	11	11	11	11	11	11	11	11
10	47	47	11	11	20	11	11	20	11	11	20
11	20	47	11	11	20	11	11	20	11	11	20
12	47	47	46	46	20	46	46	20	46	46	20
13	11	11	21	21	11	21	21	11	21	21	11
14	11	11	11	11	11	11	11	11	11	11	11
15	7	7	7	7	7	7	7	7	7	7	7
16	7	7	7	7	7	7	7	7	7	7	7
17	7	7	7	7	7	7	7	7	7	7	7
18	15	15	15	15	15	15	15	15	15	15	15
19	16	16	16	16	16	16	16	16	16	16	16

Information Processing Center

Information Processing Center

SPECIFICATION FOR LAYER NUMBER 8

	1	2	3	4	5	6	7	8	9	10	11
1	11	11	11	11	11	4	4	4	4	4	4
2	20	20	20	20	11	4	4	4	4	4	4
3	11	11	11	11	4	4	4	4	4	4	4
4	10	10	10	10	10	10	10	10	10	10	10
5	10	10	5	5	5	5	5	10	5	5	5
6	10	10	5	11	11	11	5	10	5	5	5
7	10	10	5	5	5	5	5	10	5	5	5
8	11	11	6	6	6	6	6	11	6	6	6
9	11	11	11	11	11	11	11	11	11	11	11
10	20	20	11	11	20	11	11	20	11	11	20
11	20	20	11	11	20	11	11	20	11	11	20
12	20	20	21	21	20	21	21	20	21	21	20
13	11	11	21	21	11	21	21	11	21	21	11
14	11	11	11	11	11	11	11	11	11	11	11
15	7	7	7	7	7	7	7	7	7	7	7
16	7	7	7	7	7	7	7	7	7	7	7
17	7	7	7	7	7	7	7	7	7	7	7
18	15	15	15	15	15	15	15	15	15	15	15
19	16	16	16	16	16	16	16	16	16	16	16

SPECIFICATION FOR LAYER NUMBER 9

	1	2	3	4	5	6	7	8	9	10	11
1	11	11	11	11	11	4	4	4	4	4	4
2	20	20	20	20	11	4	4	4	4	4	4
3	11	11	11	11	4	4	4	4	4	4	4
4	10	10	10	10	10	10	10	10	10	10	10
5	10	10	5	5	5	5	5	10	5	5	5
6	10	10	5	11	11	11	5	10	5	5	5
7	10	10	5	5	5	5	5	10	5	5	5
8	11	11	6	6	6	6	6	11	6	6	6
9	11	11	11	11	11	11	11	11	11	11	11
10	20	20	11	11	20	11	11	20	11	11	20
11	20	20	11	11	20	11	11	20	11	11	20
12	20	20	21	21	20	21	21	20	21	21	20
13	11	11	21	21	11	21	21	11	21	21	11
14	11	11	11	11	11	11	11	11	11	11	11
15	7	7	7	7	7	7	7	7	7	7	7
16	7	7	7	7	7	7	7	7	7	7	7
17	7	7	7	7	7	7	7	7	7	7	7
18	15	15	15	15	15	15	15	15	15	15	15
19	16	16	16	16	16	16	16	16	16	16	16

Information Processing Center

Information Processing Center

SPECIFICATION FOR LAYER NUMBER 10

	1	2	3	4	5	6	7	8	9	10	11
1	11	11	11	11	11	3	3	3	3	3	3
2	20	20	20	20	11	3	3	3	3	3	3
3	11	11	11	11	3	3	3	3	3	3	3
4	10	10	10	10	10	10	10	10	10	10	10
5	10	10	5	5	5	5	5	10	5	5	5
6	10	10	5	11	11	11	5	10	5	5	5
7	10	10	5	5	5	5	5	10	5	5	5
8	11	11	1	1	1	1	1	11	1	1	1
9	11	11	11	11	11	11	11	11	11	11	11
10	20	20	11	11	20	11	11	20	11	11	20
11	20	20	11	11	20	11	11	20	11	11	20
12	20	20	21	21	20	21	21	20	21	21	20
13	11	11	21	21	11	21	21	11	21	21	11
14	11	11	11	11	11	11	11	11	11	11	11
15	7	7	7	7	7	7	7	7	7	7	7
16	7	7	7	7	7	7	7	7	7	7	7
17	7	7	7	7	7	7	7	7	7	7	7
18	15	15	15	15	15	15	15	15	15	15	15
19	16	16	16	16	16	16	16	16	16	16	16

Information Processing Center

Information Processing Center

SPECIFICATION FOR LAYER NUMBER 11

	1	2	3	4	5	6	7	8	9	10	11
1	11	11	11	11	11	3	3	3	3	3	3
2	20	20	20	20	11	3	3	3	3	3	3
3	11	11	11	11	3	3	3	3	3	3	3
4	10	10	10	10	10	10	10	10	10	10	10
5	10	10	5	5	5	5	5	10	5	5	5
6	10	10	5	11	11	11	5	10	5	5	5
7	10	10	5	5	5	5	5	10	5	5	5
8	11	11	1	1	1	1	1	11	1	1	1
9	11	11	11	11	11	11	11	11	11	11	11

10	11	11	11	11	11	11	11	11	11	11	11
11	11	11	2	2	11	2	2	11	2	2	11
12	11	11	21	21	11	21	21	11	21	21	11
13	11	11	21	21	11	21	21	11	21	21	11
14	11	11	11	11	11	11	11	11	11	11	11
15	7	7	7	7	7	7	7	7	7	7	7
16	7	7	7	7	7	7	7	7	7	7	7
17	7	7	7	7	7	7	7	7	7	7	7
18	15	15	15	15	15	15	15	15	15	15	15
19	16	16	16	16	16	16	16	16	16	16	16

Information Processing Center

SPECIFICATION FOR LAYER NUMBER 12

	1	2	3	4	5	6	7	8	9	10	11
1	2	2	2	2	2	2	2	2	2	2	2
2	20	20	20	20	2	2	2	2	2	2	2
3	2	2	2	2	2	2	2	2	2	2	2
4	10	10	10	10	10	10	10	10	10	10	10
5	2	2	2	2	2	2	2	2	2	2	2
6	2	2	2	2	2	2	2	2	2	2	2
7	2	2	2	2	2	2	2	2	2	2	2
8	2	2	2	2	2	2	2	2	2	2	2
9	11	11	11	11	11	11	11	11	11	11	11
10	11	11	11	11	11	11	11	11	11	11	11
11	11	11	2	2	11	2	2	11	2	2	11
12	11	11	21	21	11	21	21	11	21	21	11
13	11	11	21	21	11	21	21	11	21	21	11
14	11	11	11	11	11	11	11	11	11	11	11
15	7	7	7	7	7	7	7	7	7	7	7
16	7	7	7	7	7	7	7	7	7	7	7
17	7	7	7	7	7	7	7	7	7	7	7
18	15	15	15	15	15	15	15	15	15	15	15
19	16	16	16	16	16	16	16	16	16	16	16

Information Processing Center

SPECIFICATION FOR LAYER NUMBER 13

	1	2	3	4	5	6	7	8	9	10	11
1	24	24	24	24	24	24	24	24	24	24	24
2	24	24	24	24	24	24	24	24	24	24	24
3	24	24	24	24	24	24	24	24	24	24	24
4	10	10	10	10	10	10	10	10	10	10	10
5	24	24	24	24	24	24	24	24	24	24	24
6	24	24	24	24	24	24	24	24	24	24	24
7	24	24	24	24	24	24	24	24	24	24	24
8	24	24	24	24	24	24	24	24	24	24	24
9	11	11	11	11	11	11	11	11	11	11	11
10	11	11	11	11	11	11	11	11	11	11	11
11	11	11	2	2	11	2	2	11	2	2	11
12	11	11	21	21	11	21	21	11	21	21	11
13	11	11	21	21	11	21	21	11	21	21	11
14	11	11	11	11	11	11	11	11	11	11	11
15	7	7	7	7	7	7	7	7	7	7	7
16	7	7	7	7	7	7	7	7	7	7	7
17	7	7	7	7	7	7	7	7	7	7	7
18	15	15	15	15	15	15	15	15	15	15	15
19	16	16	16	16	16	16	16	16	16	16	16

Information Processing Center

SPECIFICATION FOR LAYER NUMBER 14

	1	2	3	4	5	6	7	8	9	10	11
1	2	2	2	2	2	2	2	2	2	2	2
2	2	2	2	2	2	2	2	2	2	2	2
3	2	2	2	2	2	2	2	2	2	2	2
4	10	10	10	10	10	10	10	10	10	10	10
5	2	2	2	2	2	2	2	2	2	2	2
6	2	2	2	2	2	2	2	2	2	2	2
7	2	2	2	2	2	2	2	2	2	2	2
8	2	2	2	2	2	2	2	2	2	2	2
9	20	20	20	20	20	20	20	20	20	20	20
10	2	2	2	2	2	2	2	2	2	2	2
11	2	2	2	2	2	2	2	2	2	2	2
12	21	21	21	21	21	21	21	21	21	21	21
13	11	11	11	11	11	11	11	11	11	11	11
14	11	11	11	11	11	11	11	11	11	11	11
15	7	7	7	7	7	7	7	7	7	7	7
16	7	7	7	7	7	7	7	7	7	7	7
17	7	7	7	7	7	7	7	7	7	7	7
18	15	15	15	15	15	15	15	15	15	15	15
19	16	16	16	16	16	16	16	16	16	16	16

Information Processing Center

Information Processing Center

SPECIFICATION FOR LAYER NUMBER 15

	1	2	3	4	5	6	7	8	9	10	11
1	17	17	17	17	17	17	17	17	17	17	17
2	17	17	17	17	17	17	17	17	17	17	17
3	17	17	17	17	17	17	17	17	17	17	17
4	10	10	10	10	10	10	10	10	10	10	10
5	17	17	17	17	17	17	17	17	17	17	17
6	17	17	17	17	17	17	17	17	17	17	17
7	2	2	2	2	2	2	2	2	2	2	2
8	2	2	2	2	2	2	2	2	2	2	2
9	2	2	2	2	2	2	2	2	2	2	2
10	2	2	2	2	2	2	2	2	2	2	2
11	7	7	7	7	7	7	7	7	7	7	7
12	7	7	7	7	7	7	7	7	7	7	7
13	7	7	7	7	7	7	7	7	7	7	7
14	7	7	7	7	7	7	7	7	7	7	7
15	7	7	7	7	7	7	7	7	7	7	7
16	7	7	7	7	7	7	7	7	7	7	7
17	7	7	7	7	7	7	7	7	7	7	7
18	15	15	15	15	15	15	15	15	15	15	15
19	16	16	16	16	16	16	16	16	16	16	16

Information Processing Center

Information Processing Center

SPECIFICATION FOR LAYER NUMBER 16

	1	2	3	4	5	6	7	8	9	10	11
1	7	7	20	20	20	20	20	7	20	20	20
2	7	7	20	20	20	20	20	7	20	20	20
3	20	20	20	20	20	20	20	20	20	20	20
4	20	20	20	20	20	20	20	20	20	20	20
5	20	20	20	20	20	20	20	20	20	20	20
6	20	20	20	20	20	20	20	20	20	20	20
7	20	20	20	20	20	20	20	20	20	20	20
8	20	20	20	20	20	20	20	20	20	20	20
9	17	17	17	17	17	17	17	17	17	17	17
10	7	7	7	7	7	7	7	7	7	7	7
11	7	7	7	7	7	7	7	7	7	7	7

12	7	7	7	7	7	7	7	7	7	7	7
13	7	7	7	7	7	7	7	7	7	7	7
14	7	7	7	7	7	7	7	7	7	7	7
15	7	7	7	7	7	7	7	7	7	7	7
16	7	7	7	7	7	7	7	7	7	7	7
17	7	7	7	7	7	7	7	7	7	7	7
18	15	15	15	15	15	15	15	15	15	15	15
19	16	16	16	16	16	16	16	16	16	16	16

SPECIFICATION FOR LAYER NUMBER 17

	1	2	3	4	5	6	7	8	9	10	11
1	7	7	7	7	7	7	7	7	7	7	7
2	7	7	7	7	7	7	7	7	7	7	7
3	7	7	7	7	7	7	7	7	7	7	7
4	7	7	7	7	7	7	7	7	7	7	7
5	7	7	7	7	25	25	25	25	26	26	25
6	7	7	7	7	25	25	25	25	26	26	25
7	7	7	7	7	27	27	27	27	26	26	25
8	7	7	7	7	27	27	27	27	26	26	25
9	7	7	7	7	27	29	29	27	28	28	25
10	7	7	7	7	27	29	29	27	28	28	25
11	7	7	7	7	27	29	29	27	28	28	25
12	7	7	7	7	27	29	29	27	28	28	25
13	7	7	7	7	27	29	29	27	28	28	25
14	7	7	7	7	27	29	29	27	28	28	25
15	7	7	7	7	27	29	29	27	28	28	25
16	7	7	7	7	29	30	30	29	30	30	25
17	7	7	7	7	27	31	31	7	26	26	29
18	15	15	15	15	27	31	31	7	26	26	29
19	16	16	16	16	16	32	32	16	32	32	32

SPECIFICATION FOR LAYER NUMBER 18

	1	2	3	4	5	6	7	8	9	10	11
1	7	7	7	7	7	7	7	7	7	7	7
2	7	7	7	7	7	7	7	7	7	7	7
3	7	7	7	7	7	7	7	7	7	7	7
4	7	7	7	7	7	7	7	7	7	7	7
5	7	7	7	7	25	25	25	25	26	26	25
6	7	7	7	7	25	25	25	25	26	26	25
7	7	7	7	7	27	27	27	27	26	26	25
8	7	7	7	7	27	27	27	27	26	26	25
9	7	7	7	7	27	29	29	27	28	28	25
10	7	7	7	7	27	29	29	27	28	28	25
11	7	7	7	7	27	29	29	27	28	28	25
12	7	7	7	7	27	29	29	27	28	28	25
13	7	7	7	7	27	29	29	27	28	28	25
14	7	7	7	7	27	29	29	27	28	28	25
15	7	7	7	7	27	29	29	27	28	28	25
16	7	7	7	7	29	30	30	29	30	30	25
17	7	7	7	7	27	31	31	7	26	26	29
18	15	15	15	15	27	31	31	15	26	26	29
19	16	16	16	16	16	32	32	16	32	32	32

SPECIFICATION FOR LAYER NUMBER 19

	1	2	3	4	5	6	7	8	9	10	11
--	---	---	---	---	---	---	---	---	---	----	----

1	7	7	7	7	7	7	7	7	7	7	7
2	7	7	7	7	7	7	7	7	7	7	7
3	7	7	7	7	7	7	7	7	7	7	7
4	7	7	7	7	7	7	7	7	7	7	7
5	7	7	7	7	7	7	7	7	7	7	7
6	7	7	7	7	7	7	7	7	7	7	7
7	7	7	7	7	7	7	7	7	7	7	7
8	7	7	7	7	7	7	7	7	7	7	7
9	7	7	7	7	7	7	7	7	7	7	7
10	7	7	7	7	7	7	7	7	7	7	7
11	7	7	7	7	7	7	7	7	7	7	7
12	7	7	7	7	7	7	7	7	7	7	7
13	7	7	7	7	7	7	7	7	7	7	7
14	7	7	7	7	7	7	7	7	7	7	7
15	7	7	7	7	7	7	7	7	7	7	7
16	7	7	7	7	7	7	7	7	7	7	7
17	7	7	7	7	7	7	7	7	7	7	7
18	15	15	15	15	15	15	15	15	15	15	15
19	16	16	16	16	16	16	16	16	16	16	16

Information Processing Center

Information Processing Center

SPECIFICATION FOR LAYER NUMBER 20

	1	2	3	4	5	6	7	8	9	10	11
1	7	7	7	7	7	7	7	7	7	7	7
2	7	7	7	7	7	7	7	7	7	7	7
3	7	7	7	7	7	7	7	7	7	7	7
4	7	7	7	7	7	7	7	7	7	7	7
5	7	7	7	7	7	7	7	7	7	7	7
6	7	7	7	7	7	7	7	7	7	7	7
7	7	7	7	7	7	7	7	7	7	7	7
8	7	7	7	7	7	7	7	7	7	7	7
9	7	7	7	7	7	7	7	7	7	7	7
10	7	7	7	7	7	7	7	7	7	7	7
11	7	7	7	7	7	7	7	7	7	7	7
12	7	7	7	7	7	7	7	7	7	7	7
13	7	7	7	7	7	7	7	7	7	7	7
14	7	7	7	7	7	7	7	7	7	7	7
15	7	7	7	7	7	7	7	7	7	7	7
16	7	7	7	7	7	7	7	7	7	7	7
17	7	7	7	7	7	7	7	7	7	7	7
18	15	15	15	15	15	15	15	15	15	15	15
19	16	16	16	16	16	16	16	16	16	16	16

Information Processing Center

Information Processing Center

DESCRIPTION OF REACTOR ZONES

ZN TO ZN	SUB-ZNS	SIGMA-SET	ID	CLASS	DPL	NEX	NAME
1	1	0	1	0	0	-1	CORE
2	2	0	1	0	0	-1	H2O+AL
3	6	0	1	0	0	-1	CORE
7	7	0	1	0	0	-1	D2O+H2O+AL
8	8	0	1	0	0	-1	PB
9	9	0	1	0	0	-1	CD+AL
10	11	0	1	0	0	-1	AL
12	12	0	1	0	0	-1	D2O
13	14	0	1	0	0	-1	CORE
15	15	0	1	0	0	-1	AL+H2O
16	16	0	1	0	0	-1	C
17	17	0	1	0	0	-1	AL+D2O
18	18	0	1	0	0	-1	H2O
19	19	0	1	0	0	-1	AL+H2O

20	21	0	1	0	0	-1	0	H2O
22	23	0	1	0	0	-1	0	CORE+AL-H2O
24	24	0	1	0	0	-1	0	AL+H2O
25	26	0	1	0	0	-1	0	AL+D2O+VOID
27	27	0	1	0	0	-1	0	AL+VOID
28	32	0	1	0	0	-1	0	AL+D2O+VOID
33	39	0	1	0	0	-1	0	CORE-H2O
40	40	0	1	0	0	-1	0	AL+H2O
41	41	0	1	0	0	-1	0	VOID
42	42	0	1	0	0	-1	0	H2O
43	43	0	1	0	0	-1	0	H2O
44	44	0	1	0	0	-1	0	HF+AL
45	45	0	1	0	0	-1	0	HF+AL
46	46	0	1	0	0	-1	0	B-SS
47	47	0	1	0	0	-1	0	CD+AL

DESCRIPTION OF MICROSCOPIC CROSS SECTIONS

SMT	NUCS	GRPS	UPSC	DWSC	TITLE
1	66	3	0	2	MICROSCOPIC CROSS-SECTIONS FOR THE NTR-II
GROUP	UPPER ENERGY	MEAN ENERGY	1/V X-SECTION	DIST. FUNC	
1	1.000000E+07	5.477200E+04	1.990000E-09	1.000000	
2	3.000000E+03	3.464000E+01	2.778000E-07	0.0	
3	4.000000E-01	1.000000E-02	4.247000E-06	0.0	
SUM				1.000000	

INPUT NUCLIDE DENSITIES (NUCLIDE NUMBER - DENSITY)

ZONES 1-	1	SUB-ZONE INDICATOR	0	AND CONTROL OPTION	0
1	4.39000E-04	2	3.35900E-05	4	3.18300E-02
3	1.54500E-02				
ZONES 2-	2	SUB-ZONE INDICATOR	0	AND CONTROL OPTION	0
33	3.01200E-02	32	1.65500E-02		
ZONES 3-	3	SUB-ZONE INDICATOR	0	AND CONTROL OPTION	0
5	4.39000E-04	6	3.35900E-05	8	3.18300E-02
7	1.54500E-02				
ZONES 4-	4	SUB-ZONE INDICATOR	0	AND CONTROL OPTION	0
9	4.39000E-04	10	3.35900E-05	11	3.18300E-02
12	1.54500E-02				
ZONES 5-	5	SUB-ZONE INDICATOR	0	AND CONTROL OPTION	0
15	4.39000E-04	16	3.35900E-05	13	3.18300E-02
14	1.54500E-02				
ZONES 6-	6	SUB-ZONE INDICATOR	0	AND CONTROL OPTION	0
17	4.39000E-04	18	3.35900E-05	20	3.18300E-02
19	1.54500E-02				
ZONES 7-	7	SUB-ZONE INDICATOR	0	AND CONTROL OPTION	0
21	3.27500E-02	22	1.62100E-04	47	1.64570E-04
ZONES 8-	8	SUB-ZONE INDICATOR	0	AND CONTROL OPTION	0
34	3.29500E-02				
ZONES 9-	9	SUB-ZONE INDICATOR	0	AND CONTROL OPTION	0
66	7.41600E-03	35	5.06000E-02		
ZONES 10-	10	SUB-ZONE INDICATOR	0	AND CONTROL OPTION	0
38	6.02300E-02				
ZONES 11-	11	SUB-ZONE INDICATOR	0	AND CONTROL OPTION	0
53	6.02300E-02				
ZONES 12-	12	SUB-ZONE INDICATOR	0	AND CONTROL OPTION	0
54	6.02300E-02				

Information Processing Center

Information Processing Center

Information Processing Center

Information Processing Center

ZONES 13- 13	SUB-ZONE INDICATOR 0	AND CONTROL OPTION 0			
24	4.39000E-04	25 3.35900E-05	26 3.18300E-02	27 1.54500E-02	
ZONES 14- 14	SUB-ZONE INDICATOR 0	AND CONTROL OPTION 0			
28	4.39000E-04	29 3.35900E-05	30 3.18300E-02	31 1.54500E-02	
ZONES 15- 15	SUB-ZONE INDICATOR 0	AND CONTROL OPTION 0			
40	3.01200E-02	39 1.65500E-02			
ZONES 16- 16	SUB-ZONE INDICATOR 0	AND CONTROL OPTION 0			
41	8.33400E-02				
ZONES 17- 17	SUB-ZONE INDICATOR 0	AND CONTROL OPTION 0			
42	1.65400E-02	43 3.12000E-02			
ZONES 18- 18	SUB-ZONE INDICATOR 0	AND CONTROL OPTION 0			
44	3.34000E-02				
ZONES 19- 19	SUB-ZONE INDICATOR 0	AND CONTROL OPTION 0			
45	3.14300E-02	46 3.01200E-03			
ZONES 20- 20	SUB-ZONE INDICATOR 0	AND CONTROL OPTION 0			
47	3.34000E-02				
ZONES 21- 21	SUB-ZONE INDICATOR 0	AND CONTROL OPTION 0			
48	3.34000E-02				
ZONES 22- 22	SUB-ZONE INDICATOR 0	AND CONTROL OPTION 0			
28	4.39000E-04	29 3.35900E-05	30 5.40400E-02	31 3.09000E-03	
ZONES 23- 23	SUB-ZONE INDICATOR 0	AND CONTROL OPTION 0			
15	4.39000E-04	16 3.35900E-05	13 5.40400E-02	14 3.09000E-03	
ZONES 24- 24	SUB-ZONE INDICATOR 0	AND CONTROL OPTION 0			
52	6.02300E-03	51 3.00600E-02			
ZONES 25- 25	SUB-ZONE INDICATOR 0	AND CONTROL OPTION 0			
21	1.32920E-02	22 5.42160E-03	56 5.10000E-01		
ZONES 26- 26	SUB-ZONE INDICATOR 0	AND CONTROL OPTION 0			
21	2.09350E-02	22 3.01200E-03	56 3.20000E-01		
ZONES 27- 27	SUB-ZONE INDICATOR 0	AND CONTROL OPTION 0			
22	9.03600E-03	56 8.20000E-01			
ZONES 28- 28	SUB-ZONE INDICATOR 0	AND CONTROL OPTION 0			
21	1.52860E-02	22 4.81920E-03	56 4.60000E-01		
ZONES 29- 29	SUB-ZONE INDICATOR 0	AND CONTROL OPTION 0			
21	9.96900E-03	22 3.61440E-03	56 3.40000E-01		
ZONES 30- 30	SUB-ZONE INDICATOR 0	AND CONTROL OPTION 0			
21	1.72800E-02	22 4.21680E-03	56 4.10000E-01		
ZONES 31- 31	SUB-ZONE INDICATOR 0	AND CONTROL OPTION 0			
21	1.99380E-02	22 3.61440E-03	56 3.40000E-01		
ZONES 32- 32	SUB-ZONE INDICATOR 0	AND CONTROL OPTION 0			
21	2.59190E-02	22 1.80720E-03	56 1.90000E-01		
ZONES 33- 33	SUB-ZONE INDICATOR 0	AND CONTROL OPTION 0			
5	4.39000E-04	6 3.35900E-05	8 3.18300E-02		
ZONES 34- 34	SUB-ZONE INDICATOR 0	AND CONTROL OPTION 0			
9	4.39000E-04	10 3.35900E-05	11 3.18300E-02		

Information Processing Center

Information Processing Center

Information Processing Center

Information Processing Center

ZONES 35- 35 SUB-ZONE INDICATOR 0 AND CONTROL OPTION 0
15 4.39000E-04 16 3.35900E-05 13 3.18300E-02

ZONES 36- 36 SUB-ZONE INDICATOR 0 AND CONTROL OPTION 0
24 4.39000E-04 25 3.35900E-05 26 3.18300E-02

ZONES 37- 37 SUB-ZONE INDICATOR 0 AND CONTROL OPTION 0
28 4.39000E-04 29 3.35900E-05 30 3.18300E-02

ZONES 38- 38 SUB-ZONE INDICATOR 0 AND CONTROL OPTION 0
17 4.39000E-04 18 3.35900E-05 20 3.18300E-02

ZONES 39- 39 SUB-ZONE INDICATOR 0 AND CONTROL OPTION 0
1 4.39000E-04 2 3.35900E-05 4 3.18300E-02

ZONES 40- 40 SUB-ZONE INDICATOR 0 AND CONTROL OPTION 0
47 1.40700E-02 54 3.49160E-02

ZONES 41- 41 SUB-ZONE INDICATOR 0 AND CONTROL OPTION 0
57 1.00000E+00

ZONES 42- 42 SUB-ZONE INDICATOR 0 AND CONTROL OPTION 0
14 3.34000E-02

ZONES 43- 43 SUB-ZONE INDICATOR 0 AND CONTROL OPTION 0
14 3.34000E-02

ZONES 44- 44 SUB-ZONE INDICATOR 0 AND CONTROL OPTION 0
60 1.53500E-02 35 4.25900E-02

ZONES 45- 45 SUB-ZONE INDICATOR 0 AND CONTROL OPTION 0
61 8.94000E-03 35 3.95600E-02

ZONES 46- 46 SUB-ZONE INDICATOR 0 AND CONTROL OPTION 0
62 9.02580E-04

ZONES 47- 47 SUB-ZONE INDICATOR 0 AND CONTROL OPTION 0
66 7.41600E-03 35 5.06000E-02

FISSILE NUCLIDES--- 8 10 14 16

FERTILE NUCLIDES--- 6 9 12 15

INTERMEDIATE NUCLIDES--- 7 13

OTHER NUCLIDES--- 11 17 18 19 20 21

STRUCTURAL NUCLIDES--- 26 27 31 32 33 34 35 37 38 39 45 46 47

SPECIAL NUCLIDES--- 1 2 3 5 23

FISSION PRODUCT NUCLIDES--- 48 49 50 51 52 53 54 55 56 57 58 59 60 61 62 63 64 65 66

COBN STORAGE DIFFERENCE (WORDS) EQUATION CONSTANTS I/O INSTEAD OF STORED 35058

EQUATION CONSTANTS WILL BE STORED ON I/O LOGICAL 15

NUMBER OF---COLUMNS, ROWS, PLANES, GROUPS, UPSCAT, DOWNSCAT, REGIONS, AND ZONES 11 19 20 3 0 24180 47

MEMORY LOCATIONS RESERVED FOR DATA STORAGE--- 118000

MEMORY LOCATIONS USED FOR THIS PROBLEM----- 86421

MEMORY LOCATIONS NOT USED----- 31579

*****WARNING***** INPUT SPECIFIED DOWNSCATTER = 2 HAS BEEN CHANGED TO ACTUAL DOWNSCATTER = 1

Information Processing Center

Information Processing Center

Information Processing Center

Information Processing Center

ZONE MACROSCOPIC CROSS SECTIONS

ZONE	NAME	GRP	D	SIGR	SIGA	NUSIGP	BSQ	POWER/FLUX
1	CORE	1	1.62978E+00	3.28883E-02	1.09096E-03	2.00322E-03	0.0	2.60717E-14
		2	8.34367E-01	6.27993E-02	1.96769E-02	3.05681E-02	0.0	4.02591E-13
		3	2.62836E-01	0.0	2.05109E-01	3.95271E-01	0.0	5.22140E-12
2	H2O+AL	1	1.75611E+00	4.09290E-02	1.72222E-04	0.0	0.0	0.0
		2	8.22862E-01	7.34039E-02	1.16531E-03	0.0	0.0	0.0
		3	2.49859E-01	0.0	1.81103E-02	0.0	0.0	0.0
3	CORE	1	1.61766E+00	3.36421E-02	1.08494E-03	2.01097E-03	0.0	2.62119E-14
		2	8.34613E-01	6.21418E-02	1.96273E-02	3.04778E-02	0.0	4.01401E-13
		3	2.62836E-01	0.0	2.05109E-01	3.95271E-01	0.0	5.22140E-12
4	CORE	1	1.78490E+00	3.38145E-02	1.09028E-03	2.01348E-03	0.0	2.62407E-14
		2	8.35597E-01	5.91986E-02	1.93564E-02	3.00046E-02	0.0	3.95170E-13
		3	3.05314E-01	0.0	1.70584E-01	3.26725E-01	0.0	4.31593E-12
5	CORE	1	1.79755E+00	3.32924E-02	1.09130E-03	2.00887E-03	0.0	2.61380E-14
		2	8.35722E-01	5.94504E-02	1.93690E-02	3.00358E-02	0.0	3.95581E-13
		3	3.03235E-01	0.0	1.72317E-01	3.30777E-01	0.0	4.36946E-12
6	CORE	1	1.63257E+00	3.25618E-02	1.08839E-03	1.99930E-03	0.0	2.60148E-14
		2	8.34845E-01	6.16431E-02	1.95829E-02	3.03960E-02	0.0	4.00325E-13
		3	2.62836E-01	0.0	2.05109E-01	3.95271E-01	0.0	5.22140E-12
7	D2O+H2O+AL	1	1.43073E+00	2.27943E-02	8.27860E-05	0.0	0.0	0.0
		2	1.20494E+00	2.13851E-02	1.05985E-05	0.0	0.0	0.0
		3	7.70232E-01	0.0	1.76033E-04	0.0	0.0	0.0
8	PB	1	1.72041E+00	4.79752E-04	1.02293E-04	0.0	0.0	0.0
		2	9.08600E-01	3.83538E-04	2.83798E-04	0.0	0.0	0.0
		3	9.08926E-01	0.0	1.58160E-03	0.0	0.0	0.0
9	CD+AL	1	1.96928E+00	4.17163E-04	1.61449E-03	0.0	0.0	0.0
		2	2.04424E+00	4.21599E-04	8.29796E-02	0.0	0.0	0.0
		3	1.56732E-01	0.0	4.11219E+02	0.0	0.0	0.0
10	AL	1	2.65500E+00	3.71354E-04	1.71999E-04	0.0	0.0	0.0
		2	4.01942E+00	5.72155E-04	7.42576E-04	0.0	0.0	0.0
		3	3.60168E+00	0.0	9.52056E-03	0.0	0.0	0.0
11	AL	1	2.66638E+00	3.99500E-04	1.97850E-04	0.0	0.0	0.0
		2	4.01738E+00	6.03565E-04	8.94777E-04	0.0	0.0	0.0
		3	3.46091E+00	0.0	1.46606E-02	0.0	0.0	0.0
12	D2O	1	2.71624E+00	4.94452E-04	2.20117E-04	0.0	0.0	0.0
		2	4.01476E+00	6.78912E-04	1.02969E-03	0.0	0.0	0.0
		3	3.46091E+00	0.0	1.59357E-02	0.0	0.0	0.0
13	CORE	1	1.78164E+00	3.49311E-02	1.09921E-03	2.02727E-03	0.0	2.64114E-14
		2	8.36273E-01	5.74405E-02	1.92940E-02	2.98306E-02	0.0	3.92862E-13
		3	3.05314E-01	0.0	1.70584E-01	3.26725E-01	0.0	4.31593E-12
14	CORE	1	1.79914E+00	3.36473E-02	1.07665E-03	2.01382E-03	0.0	2.61899E-14
		2	8.35458E-01	5.94802E-02	1.94206E-02	3.00907E-02	0.0	3.96303E-13
		3	3.05314E-01	0.0	1.70584E-01	3.26725E-01	0.0	4.31593E-12
15	AL+H2O	1	1.42966E+00	1.01260E-01	1.55308E-04	0.0	0.0	0.0
		2	8.09527E-01	1.08839E-01	1.56547E-03	0.0	0.0	0.0
		3	2.49859E-01	0.0	1.81103E-02	0.0	0.0	0.0
16	C	1	1.29301E+00	9.16450E-03	0.0	0.0	0.0	0.0
		2	9.08544E-01	1.02291E-02	8.47568E-06	0.0	0.0	0.0
		3	8.47624E-01	0.0	2.49286E-04	0.0	0.0	0.0

Information Processing Center

Information Processing Center

Information Processing Center

Information Processing Center

Information Processing Center	17	AL+D20	1	1.91839E+00	7.53674E-03	1.72139E-04	0.0	0.0	0.0
			2	1.84655E+00	9.70257E-03	5.52131E-04	0.0	0.0	0.0
			3	1.27290E+00	0.0	8.27121E-03	0.0	0.0	0.0
	18	H20	1	1.39896E+00	7.46055E-02	1.55454E-04	0.0	0.0	0.0
			2	4.52630E-01	1.62852E-01	1.41556E-03	0.0	0.0	0.0
			3	1.28445E-01	0.0	2.04662E-02	0.0	0.0	0.0
	19	AL+H20	1	1.37749E+00	7.91092E-02	1.43090E-04	0.0	0.0	0.0
			2	4.79085E-01	1.46323E-01	1.34474E-03	0.0	0.0	0.0
			3	1.36227E-01	0.0	2.00560E-02	0.0	0.0	0.0
20	H20	1	1.24040E+00	9.34558E-02	1.20477E-04	0.0	0.0	0.0	
		2	4.53494E-01	1.54211E-01	1.35534E-03	0.0	0.0	0.0	
		3	1.28445E-01	0.0	2.04662E-02	0.0	0.0	0.0	
21	H20	1	1.24195E+00	9.06743E-02	1.16686E-04	0.0	0.0	0.0	
		2	4.54609E-01	1.44983E-01	1.29913E-03	0.0	0.0	0.0	
		3	1.28445E-01	0.0	2.04662E-02	0.0	0.0	0.0	
22	CORE+AL-H20	1	2.40212E+00	7.02450E-03	1.09647E-03	2.01382E-03	0.0	2.61899E-14	
		2	2.06240E+00	1.23471E-02	1.93395E-02	3.00907E-02	0.0	3.96303E-13	
		3	7.91444E-01	0.0	1.69736E-01	3.26725E-01	0.0	4.31593E-12	
23	CORE+AL-H20	1	2.39906E+00	6.94948E-03	1.12306E-03	2.00887E-03	0.0	2.61380E-14	
		2	2.06529E+00	1.23451E-02	1.92850E-02	3.00358E-02	0.0	3.95581E-13	
		3	7.94068E-01	0.0	1.71244E-01	3.30777E-01	0.0	4.36946E-12	
24	AL+H20	1	1.36900E+00	7.13763E-02	1.32019E-04	0.0	0.0	0.0	
		2	4.98802E-01	1.30121E-01	1.24397E-03	0.0	0.0	0.0	
		3	1.42130E-01	0.0	1.96944E-02	0.0	0.0	0.0	
25	AL+D20+VOID	1	2.64722E+00	9.13870E-03	5.39080E-05	0.0	0.0	0.0	
		2	2.37527E+00	8.44473E-03	1.02350E-04	0.0	0.0	0.0	
		3	1.64809E+00	0.0	1.44756E-03	0.0	0.0	0.0	
26	AL+D20+VOID	1	1.99327E+00	1.43169E-02	6.36992E-05	0.0	0.0	0.0	
		2	1.73227E+00	1.32244E-02	5.72214E-05	0.0	0.0	0.0	
		3	1.15862E+00	0.0	8.17563E-04	0.0	0.0	0.0	
27	AL+VOID	1	6.39779E+00	1.25266E-04	3.46693E-05	0.0	0.0	0.0	
		2	6.93563E+00	1.24372E-04	1.69994E-04	0.0	0.0	0.0	
		3	6.43429E+00	0.0	2.39075E-03	0.0	0.0	0.0	
28	AL+D20+VOID	1	2.43792E+00	1.04900E-02	5.65631E-05	0.0	0.0	0.0	
		2	2.16531E+00	9.69207E-03	9.10700E-05	0.0	0.0	0.0	
		3	1.48433E+00	0.0	1.29014E-03	0.0	0.0	0.0	
29	AL+D20+VOID	1	3.63227E+00	6.84777E-03	3.86975E-05	0.0	0.0	0.0	
		2	3.24308E+00	6.32732E-03	6.82628E-05	0.0	0.0	0.0	
		3	2.23666E+00	0.0	9.66131E-04	0.0	0.0	0.0	
30	AL+D20+VOID	1	2.25930E+00	1.18413E-02	5.92183E-05	0.0	0.0	0.0	
		2	1.98945E+00	1.09394E-02	7.97902E-05	0.0	0.0	0.0	
		3	1.35017E+00	0.0	1.13272E-03	0.0	0.0	0.0	
31	AL+D20+VOID	1	2.05519E+00	1.36454E-02	6.35273E-05	0.0	0.0	0.0	
		2	1.79384E+00	1.26049E-02	6.85279E-05	0.0	0.0	0.0	
		3	1.20426E+00	0.0	9.75963E-04	0.0	0.0	0.0	
32	AL+D20+VOID	1	1.71279E+00	1.76987E-02	7.14903E-05	0.0	0.0	0.0	
		2	1.47079E+00	1.63463E-02	3.46881E-05	0.0	0.0	0.0	
		3	9.69772E-01	0.0	5.03713E-04	0.0	0.0	0.0	
33	CORE-H20	1	3.75025E+00	1.97472E-04	1.02656E-03	2.01097E-03	0.0	2.62119E-14	

Information Processing Center

Information Processing Center

	2	5.19840E+00	3.21729E-04	1.90826E-02	3.04778E-02	0.0	4.01401E-13
	3	1.38458E+00	0.0	1.97164E-01	3.95271E-01	0.0	5.22140E-12
34 CORE-H2O	1	4.79420E+00	1.98416E-04	1.03231E-03	2.01348E-03	0.0	2.62407E-14
	2	5.20904E+00	3.03221E-04	1.88298E-02	3.00046E-02	0.0	3.95170E-13
	3	1.58082E+00	0.0	1.64038E-01	3.26725E-01	0.0	4.31593E-12
35 CORE-H2O	1	4.79911E+00	1.95372E-04	1.03082E-03	2.00887E-03	0.0	2.61380E-14
	2	5.21641E+00	3.04720E-04	1.88409E-02	3.00358E-02	0.0	3.95581E-13
	3	1.58880E+00	0.0	1.65687E-01	3.30777E-01	0.0	4.36946E-12
36 CORE-H2O	1	4.80770E+00	2.05709E-04	1.04185E-03	2.02727E-03	0.0	2.64114E-14
	2	5.21137E+00	2.84818E-04	1.87733E-02	2.98306E-02	0.0	3.92862E-13
	3	1.58082E+00	0.0	1.64038E-01	3.26725E-01	0.0	4.31593E-12
37 CORE-H2O	1	4.80564E+00	1.98075E-04	1.01633E-03	2.01382E-03	0.0	2.61899E-14
	2	5.20363E+00	3.02080E-04	1.88903E-02	3.00907E-02	0.0	3.96303E-13
	3	1.58082E+00	0.0	1.64038E-01	3.26725E-01	0.0	4.31593E-12
38 CORE-H2O	1	3.75610E+00	1.90924E-04	1.02736E-03	1.99930E-03	0.0	2.60148E-14
	2	5.20114E+00	3.17369E-04	1.90406E-02	3.03960E-02	0.0	4.00325E-13
	3	1.38458E+00	0.0	1.97164E-01	3.95271E-01	0.0	5.22140E-12
39 CORE-H2O	1	3.75735E+00	1.92992E-04	1.03000E-03	2.00322E-03	0.0	2.60717E-14
	2	5.19513E+00	3.25766E-04	1.91282E-02	3.05681E-02	0.0	4.02591E-13
	3	1.38458E+00	0.0	1.97164E-01	3.95271E-01	0.0	5.22140E-12
40 AL+H2O	1	1.80820E+00	3.96573E-02	1.78356E-04	0.0	0.0	0.0
	2	9.31697E-01	6.53561E-02	1.16787E-03	0.0	0.0	0.0
	3	2.90092E-01	0.0	1.78596E-02	0.0	0.0	0.0
41 VOID	1	2.73000E+00	0.0	0.0	0.0	0.0	0.0
	2	1.91681E+00	0.0	0.0	0.0	0.0	0.0
	3	1.58428E+00	0.0	0.0	0.0	0.0	0.0
42 H2O	1	1.32947E+00	7.15495E-02	1.30751E-04	0.0	0.0	0.0
	2	4.60334E-01	1.27862E-01	1.14175E-03	0.0	0.0	0.0
	3	1.73355E-01	0.0	1.43329E-02	0.0	0.0	0.0
43 H2O	1	1.32947E+00	7.15495E-02	1.30751E-04	0.0	0.0	0.0
	2	4.60334E-01	1.27862E-01	1.14175E-03	0.0	0.0	0.0
	3	1.73355E-01	0.0	1.43329E-02	0.0	0.0	0.0
44 HF+AL	1	1.70715E+00	3.07431E-04	4.09665E-03	0.0	0.0	0.0
	2	7.34511E-01	3.54860E-04	3.23359E-01	0.0	0.0	0.0
	3	3.71524E-01	0.0	8.73877E-01	0.0	0.0	0.0
45 HF+AL	1	2.48511E+00	2.85560E-04	1.95305E-03	0.0	0.0	0.0
	2	1.34400E+00	3.29614E-04	1.45286E-01	0.0	0.0	0.0
	3	7.46936E-01	0.0	4.08252E-01	0.0	0.0	0.0
46 B-SS	1	1.16132E+00	2.12123E-03	2.71066E-03	0.0	0.0	0.0
	2	3.09454E-01	1.67298E-03	1.53111E-01	0.0	0.0	0.0
	3	4.73543E-01	0.0	2.78329E+00	0.0	0.0	0.0
47 CD+AL	1	1.96928E+00	4.17163E-04	1.61449E-03	0.0	0.0	0.0
	2	2.04424E+00	4.21599E-04	8.29796E-02	0.0	0.0	0.0
	3	1.56732E-01	0.0	4.11219E+02	0.0	0.0	0.0

Information Processing Center

Information Processing Center

Information Processing Center

Information Processing Center

HOLY SAMPLE HOLDER, HF FIXED AT 12", B-SS BLADES AT 8", 24 ELEMENTS

LINE RELAXATION WILL BE DONE ON ROWS - 3 INNER ITERATION(S)

ITERATION	FLUX CHANGE	BETA	HU-1	HU-2	HU-3	K
1	3.04406E+00	1.00000	6.08812	-1.99876	0.0	0.353841
2	4.66057E+00	1.87832	6.19160	0.00062	1.05165	0.826959
3	8.38084E+00	1.78304	10.17908	0.00323	0.10221	0.788136
4	3.64698E+01	1.71492	40.82141	0.01892	3.22641	0.883745
5	4.56575E+00	1.66933	4.69094	0.01026	0.40719	0.913714
6	7.79698E+00	1.64014	9.50468	0.01194	0.44354	0.936362
7	1.66477E+00	1.62199	1.87829	0.15076	0.35550	0.948672
8	1.27987E+00	1.61090	2.04866	0.10096	0.59364	0.958072
9	-4.06362E-01	1.60420	-0.72387	-0.58005	0.50627	0.965232
10	3.02193E-01	1.6001E	-0.44146	-0.44791	0.33337	0.970448
11	-1.56903E-01	1.59777	-0.67612	-0.27918	0.01697	0.974695
12	-8.04691E-02	1.59634	0.43239	0.91111	-41.58059	0.978091
13	-7.03433E-02	1.59548	0.80382	0.89703	1.66488	0.980897
14	-6.09043E-02	1.59498	0.80491	0.91383	1.28418	0.983203
15	-5.22241E-02	1.59467	0.80525	0.91819	1.14937	0.985115
16	-4.43441E-02	1.59449	0.80477	0.92139	1.08596	
	-2.92487E-01	EXTRAPOLATION WITH		6.3035		0.996923
17	1.16472E-02	1.00000	-0.25101	-0.59601	6.80854	0.996660
18	2.51284E-02	1.59433	2.18258	1.55034	0.16151	0.996229
19	2.06633E-02	1.59429	0.84297	0.78612	0.99336	0.996002
20	-2.06549E-02	1.59426	-1.02025	-1.24354	0.94867	0.995776
21	1.42603E-02	1.59425	-0.67615	-0.56275	0.94417	0.995564
22	1.15643E-02	1.59424	0.82251	0.92200	0.92215	0.995369
23	9.47094E-03	1.59424	0.82845	0.92389	0.91706	0.995202
24	7.78103E-03	1.59424	0.82935	0.92609	0.91582	
	5.54209E-02	EXTRAPOLATION WITH		7.1779		0.994035
25	1.99318E-03	1.00000	0.25815	0.23734	7.29220	0.994030
26	-4.51303E-03	1.59423	-2.26875	-1.96562	0.03825	0.994055
27	3.66211E-03	1.59423	-0.80779	-0.96624	1.02081	0.994087
28	-4.27705E-03	1.59423	-1.17220	-0.88300	0.97112	0.994102
29	2.86484E-03	1.59423	-0.66695	-0.79915	0.97234	0.994104
30	2.64549E-03	1.59423	0.92608	0.90996	0.94818	0.994101
31	2.45094E-03	1.59423	0.92891	0.90695	0.94746	0.994092
32	2.26688E-03	1.59423	0.92717	0.91090	0.94078	
	2.56736E-02	EXTRAPOLATION WITH		11.3512		0.993950
33	-1.28049E-03	1.00000	-0.56615	-0.33358	11.44178	0.993936
34	1.06812E-03	1.59423	-0.83308	-0.23812	0.01689	0.993902
35	8.92639E-04	1.59423	0.83661	0.92545	0.99624	0.993877

END OF EIGENVALUE CALCULATION - ITERATION TIME 1.343 MINUTES

CONVERGENCE INDICATION BY MINIMIZING THE SUM OF THE SQUARES OF THE RESIDUES - RELATIVE ABSORPTION 0.9999909 K 0.9938350

LEAKAGE 8.21730E+15 TOTAL LOSSES 1.90622E+17 TOTAL PRODUCTIONS 1.89455E+17 REACTOR POWER(WATTS) 5.00000E+06

AVERAGE FLUXES BY ZONE AND GROUP

ZONE 1--CORE	8.82495E+13	3.65797E+13	3.74741E+13
ZONE 2--H2O+AL	8.85335E+12	5.31499E+12	1.68737E+13
ZONE 3--CORE	1.50963E+14	5.75238E+13	2.77111E+13
ZONE 4--CORE			

	1.90690E+14	7.14431E+13	2.58602E+13
ZONE 5--CORE	1.46671E+14	5.52332E+13	2.09988E+13
ZONE 6--CORE	1.07843E+14	4.22454E+13	2.30256E+13
ZONE 7--D20+H20+AL	2.85446E+12	3.39549E+12	3.69887E+13
ZONE 8--PB	0.0	0.0	0.0
ZONE 9--CD+AL	0.0	0.0	0.0
ZONE 10--AL	1.44996E+14	5.56932E+13	3.09163E+13
ZONE 11--AL	6.94756E+13	2.98442E+13	2.60417E+13
ZONE 12--D20	0.0	0.0	0.0
ZONE 13--CORE	7.95912E+13	2.68891E+13	8.08747E+12
ZONE 14--CORE	6.35390E+13	2.31366E+13	7.34788E+12
ZONE 15--AL+H20	1.60435E+11	3.50775E+11	1.11891E+13
ZONE 16--C	5.07038E+09	1.16345E+10	1.87012E+12
ZONE 17--AL+D20	4.62858E+13	2.93992E+13	8.13980E+13
ZONE 18--H20	5.49789E+10	3.02920E+10	2.67303E+11
ZONE 19--AL+H20	1.02793E+11	9.95228E+10	2.91065E+12
ZONE 20--H20	5.81974E+13	2.94786E+13	5.31877E+13
ZONE 21--H20	5.18437E+13	2.73560E+13	4.83134E+13
ZONE 22--CORE+AL-H20	0.0	0.0	0.0
ZONE 23--CORE+AL-H20	0.0	0.0	0.0
ZONE 24--AL+H20	6.89403E+13	3.62678E+13	7.54265E+13
ZONE 25--AL+D20+VOID	1.81059E+13	1.59661E+13	7.52357E+13
ZONE 26--AL+D20+VOID			

Information Processing Center

Information Processing Center

Information Processing Center

Information Processing Center

	3.87492E+12	4.27319E+12	4.40263E+13
Information Processing Center	ZONE 27--AL+VOID		
	1.05763E+13	9.50293E+12	5.73171E+13
	ZONE 28--AL+D20+VOID		
	1.41021E+13	1.38567E+13	7.32870E+13
	ZONE 29--AL+D20+VOID		
	8.64666E+12	8.94822E+12	6.13159E+13
	ZONE 30--AL+D20+VOID		
	4.42877E+12	6.51686E+12	6.12749E+13
	ZONE 31--AL+D20+VOID		
	8.26048E+11	1.69194E+12	3.56781E+13
	ZONE 32--AL+D20+VOID		
	1.02436E+10	2.78253E+10	3.14875E+12
	ZONE 33--CORE-H2O		
	0.0	0.0	0.0
	ZONE 34--CORE-H2O		
	0.0	0.0	0.0
	ZONE 35--CORE-H2O		
	0.0	0.0	0.0
	ZONE 36--CORE-H2O		
	0.0	0.0	0.0
	ZONE 37--CORE-H2O		
	0.0	0.0	0.0
	ZONE 38--CORE-H2O		
	0.0	0.0	0.0
	ZONE 39--CORE-H2O		
	0.0	0.0	0.0
Information Processing Center	ZONE 40--AL+H2O		
	0.0	0.0	0.0
	ZONE 41--VOID		
	0.0	0.0	0.0
	ZONE 42--H2O		
	0.0	0.0	0.0
	ZONE 43--H2O		
	0.0	0.0	0.0
	ZONE 44--HF+AL		
	7.54619E+13	2.16447E+13	3.84549E+12
	ZONE 45--HF+AL		
	5.85490E+13	1.49441E+13	1.92933E+12
	ZONE 46--B-SS		
	2.32266E+13	9.82632E+12	1.88910E+12
	ZONE 47--CD+AL		
	2.20520E+13	8.87815E+12	1.36564E+10

Information Processing Center

Information Processing Center

HOLY SAMPLE HOLDER, HF FIXED AT 12", B-SS BLADES AT 8", 24 ELEMENTS

GROUP 1 FLUX

PLANE NUMBER 1

	1	2	3	4	5	6	7	8	9	10	11
1	2.892E+11	2.892E+11	2.892E+11	2.904E+11	2.911E+11	2.917E+11	2.935E+11	2.950E+11	2.963E+11	2.970E+11	2.971E+11
2	2.837E+11	2.838E+11	2.838E+11	2.857E+11	2.866E+11	2.876E+11	2.904E+11	2.927E+11	2.950E+11	2.962E+11	2.963E+11
3	2.781E+11	2.781E+11	2.783E+11	2.806E+11	2.818E+11	2.831E+11	2.865E+11	2.897E+11	2.928E+11	2.946E+11	2.947E+11
4	2.726E+11	2.726E+11	2.727E+11	2.756E+11	2.770E+11	2.784E+11	2.822E+11	2.860E+11	2.896E+11	2.919E+11	2.920E+11
5	2.663E+11	2.663E+11	2.663E+11	2.698E+11	2.714E+11	2.730E+11	2.771E+11	2.815E+11	2.857E+11	2.884E+11	2.886E+11
6	2.434E+11	2.434E+11	2.433E+11	2.485E+11	2.506E+11	2.525E+11	2.565E+11	2.626E+11	2.682E+11	2.725E+11	2.727E+11
7	2.044E+11	2.043E+11	2.030E+11	2.066E+11	2.082E+11	2.103E+11	2.150E+11	2.209E+11	2.273E+11	2.321E+11	2.321E+11
8	1.849E+11	1.846E+11	1.803E+11	1.826E+11	1.830E+11	1.860E+11	1.907E+11	1.943E+11	2.023E+11	2.066E+11	2.057E+11
9	1.782E+11	1.778E+11	1.716E+11	1.735E+11	1.731E+11	1.767E+11	1.814E+11	1.837E+11	1.926E+11	1.967E+11	1.967E+11
10	1.747E+11	1.742E+11	1.655E+11	1.671E+11	1.659E+11	1.702E+11	1.749E+11	1.760E+11	1.858E+11	1.898E+11	1.873E+11
11	1.700E+11	1.699E+11	1.608E+11	1.623E+11	1.603E+11	1.653E+11	1.699E+11	1.700E+11	1.806E+11	1.845E+11	1.811E+11
12	1.649E+11	1.646E+11	1.549E+11	1.563E+11	1.536E+11	1.591E+11	1.636E+11	1.629E+11	1.741E+11	1.778E+11	1.738E+11
13	1.540E+11	1.534E+11	1.447E+11	1.459E+11	1.450E+11	1.486E+11	1.528E+11	1.540E+11	1.627E+11	1.663E+11	1.643E+11
14	1.430E+11	1.425E+11	1.357E+11	1.368E+11	1.365E+11	1.393E+11	1.433E+11	1.450E+11	1.526E+11	1.560E+11	1.547E+11
15	1.281E+11	1.277E+11	1.227E+11	1.238E+11	1.240E+11	1.261E+11	1.297E+11	1.319E+11	1.382E+11	1.414E+11	1.407E+11
16	3.512E+10	3.509E+10	3.473E+10	3.517E+10	3.547E+10	3.586E+10	3.692E+10	3.812E+10	3.954E+10	4.062E+10	4.066E+10
17	4.290E+09	4.288E+09	4.262E+09	4.320E+09	4.362E+09	4.409E+09	4.544E+09	4.706E+09	4.879E+09	5.019E+09	5.027E+09
18	1.854E+09	1.853E+09	1.844E+09	1.869E+09	1.888E+09	1.908E+09	1.967E+09	2.039E+09	2.114E+09	2.175E+09	2.179E+09
19	3.791E+08	3.790E+08	3.784E+08	3.844E+08	3.888E+08	3.935E+08	4.075E+08	4.231E+08	4.388E+08	4.511E+08	4.518E+08

PLANE NUMBER 2

	1	2	3	4	5	6	7	8	9	10	11
1	1.036E+13	1.036E+13	1.037E+13	1.041E+13	1.043E+13	1.045E+13	1.051E+13	1.058E+13	1.064E+13	1.067E+13	1.068E+13
2	1.009E+13	1.009E+13	1.009E+13	1.018E+13	1.024E+13	1.028E+13	1.040E+13	1.051E+13	1.062E+13	1.068E+13	1.068E+13
3	9.950E+12	9.950E+12	9.948E+12	1.005E+13	1.007E+13	1.011E+13	1.026E+13	1.043E+13	1.057E+13	1.066E+13	1.067E+13
4	9.758E+12	9.756E+12	9.728E+12	9.855E+12	9.920E+12	9.961E+12	1.012E+13	1.035E+13	1.048E+13	1.060E+13	1.062E+13
5	9.547E+12	9.544E+12	9.501E+12	9.662E+12	9.731E+12	9.795E+12	9.962E+12	1.023E+13	1.037E+13	1.051E+13	1.052E+13
6	8.792E+12	8.788E+12	8.728E+12	9.077E+12	9.166E+12	9.242E+12	9.281E+12	9.635E+12	9.816E+12	1.004E+13	1.006E+13
7	7.227E+12	7.221E+12	7.141E+12	7.326E+12	7.392E+12	7.472E+12	7.626E+12	7.952E+12	8.142E+12	8.389E+12	8.396E+12
8	6.272E+12	6.267E+12	6.194E+12	6.325E+12	6.337E+12	6.453E+12	6.610E+12	6.806E+12	7.074E+12	7.287E+12	7.247E+12
9	5.899E+12	5.895E+12	5.837E+12	5.950E+12	5.925E+12	6.071E+12	6.227E+12	6.340E+12	6.669E+12	6.869E+12	6.792E+12
10	5.644E+12	5.638E+12	5.572E+12	5.674E+12	5.607E+12	5.789E+12	5.942E+12	5.992E+12	6.366E+12	6.557E+12	6.435E+12
11	5.424E+12	5.427E+12	5.361E+12	5.456E+12	5.365E+12	5.567E+12	5.716E+12	5.732E+12	6.126E+12	6.309E+12	6.163E+12
12	5.190E+12	5.186E+12	5.044E+12	5.130E+12	5.093E+12	5.235E+12	5.376E+12	5.443E+12	5.764E+12	5.937E+12	5.854E+12
13	4.852E+12	4.839E+12	4.639E+12	4.716E+12	4.776E+12	4.812E+12	4.943E+12	5.109E+12	5.301E+12	5.463E+12	5.492E+12
14	4.511E+12	4.499E+12	4.334E+12	4.405E+12	4.459E+12	4.494E+12	4.616E+12	4.774E+12	4.952E+12	5.105E+12	5.130E+12
15	4.018E+12	4.009E+12	3.882E+12	3.944E+12	3.991E+12	4.025E+12	4.134E+12	4.277E+12	4.436E+12	4.575E+12	4.594E+12
16	9.947E+11	9.939E+11	9.829E+11	9.976E+11	1.008E+12	1.018E+12	1.048E+12	1.087E+12	1.127E+12	1.162E+12	1.164E+12
17	9.636E+10	9.630E+10	9.557E+10	9.698E+10	9.799E+10	9.904E+10	1.022E+11	1.060E+11	1.100E+11	1.135E+11	1.137E+11
18	3.688E+10	3.686E+10	3.662E+10	3.715E+10	3.754E+10	3.795E+10	3.917E+10	4.067E+10	4.221E+10	4.352E+10	4.361E+10
19	2.408E+09	2.408E+09	2.401E+09	2.439E+09	2.468E+09	2.499E+09	2.589E+09	2.690E+09	2.791E+09	2.872E+09	2.877E+09

PLANE NUMBER 3

	1	2	3	4	5	6	7	8	9	10	11
1	4.354E+13	4.354E+13	4.359E+13	4.447E+13	4.497E+13	4.570E+13	4.727E+13	4.810E+13	4.887E+13	4.924E+13	4.926E+13
2	4.107E+13	4.107E+13	4.114E+13	4.245E+13	4.397E+13	4.498E+13	4.678E+13	4.783E+13	4.881E+13	4.940E+13	4.943E+13
3	4.160E+13	4.161E+13	4.167E+13	4.258E+13	4.332E+13	4.421E+13	4.612E+13	4.734E+13	4.855E+13	4.938E+13	4.944E+13
4	4.154E+13	4.154E+13	4.166E+13	4.225E+13	4.284E+13	4.349E+13	4.561E+13	4.690E+13	4.836E+13	4.947E+13	4.957E+13
5	4.136E+13	4.138E+13	4.170E+13	4.181E+13	4.227E+13	4.283E+13	4.522E+13	4.651E+13	4.831E+13	4.974E+13	4.983E+13
6	3.935E+13	3.941E+13	4.042E+13	3.907E+13	3.936E+13	3.987E+13	4.353E+13	4.424E+13	4.750E+13	4.899E+13	5.003E+13
7	3.128E+13	3.135E+13	3.261E+13	3.373E+13	3.414E+13	3.446E+13	3.516E+13	3.495E+13	3.817E+13	4.041E+13	4.057E+13

8	2.610E+13	2.610E+13	2.619E+13	2.702E+13	2.733E+13	2.762E+13	2.821E+13	2.879E+13	3.059E+13	3.218E+13	3.227E+13
9	2.418E+13	2.417E+13	2.408E+13	2.473E+13	2.482E+13	2.529E+13	2.590E+13	2.645E+13	2.807E+13	2.941E+13	2.931E+13
10	2.277E+13	2.274E+13	2.291E+13	2.348E+13	2.288E+13	2.401E+13	2.462E+13	2.428E+13	2.668E+13	2.789E+13	2.704E+13
11	2.112E+13	2.129E+13	2.201E+13	2.252E+13	2.091E+13	2.303E+13	2.364E+13	2.215E+13	2.562E+13	2.674E+13	2.473E+13
12	1.974E+13	1.981E+13	2.031E+13	2.075E+13	1.904E+13	2.122E+13	2.180E+13	2.019E+13	2.362E+13	2.463E+13	2.249E+13
13	1.859E+13	1.856E+13	1.760E+13	1.795E+13	1.785E+13	1.835E+13	1.886E+13	1.900E+13	2.043E+13	2.128E+13	2.105E+13
14	1.763E+13	1.755E+13	1.634E+13	1.665E+13	1.702E+13	1.702E+13	1.750E+13	1.816E+13	1.895E+13	1.974E+13	2.005E+13
15	1.549E+13	1.542E+13	1.452E+13	1.479E+13	1.508E+13	1.512E+13	1.554E+13	1.613E+13	1.683E+13	1.753E+13	1.773E+13
16	3.077E+12	3.073E+12	3.015E+12	3.061E+12	3.098E+12	3.128E+12	3.225E+12	3.352E+12	3.486E+12	3.610E+12	3.624E+12
17	4.318E+11	4.315E+11	4.275E+11	4.337E+11	4.385E+11	4.433E+11	4.582E+11	4.763E+11	4.950E+11	5.111E+11	5.123E+11
18	1.400E+11	1.400E+11	1.389E+11	1.408E+11	1.424E+11	1.440E+11	1.489E+11	1.548E+11	1.608E+11	1.660E+11	1.664E+11
19	4.721E+09	4.719E+09	4.702E+09	4.778E+09	4.837E+09	4.899E+09	5.081E+09	5.281E+09	5.482E+09	5.644E+09	5.654E+09

PLANE NUMBER 4

1	7.413E+13	7.414E+13	7.422E+13	7.573E+13	7.659E+13	7.785E+13	8.065E+13	8.221E+13	8.365E+13	8.435E+13	8.439E+13
2	6.985E+13	6.985E+13	6.996E+13	7.219E+13	7.478E+13	7.651E+13	7.983E+13	8.182E+13	8.370E+13	8.478E+13	8.484E+13
3	7.059E+13	7.060E+13	7.071E+13	7.223E+13	7.350E+13	7.507E+13	7.870E+13	8.104E+13	8.335E+13	8.489E+13	8.499E+13
4	7.037E+13	7.038E+13	7.060E+13	7.152E+13	7.252E+13	7.373E+13	7.780E+13	8.028E+13	8.308E+13	8.509E+13	8.525E+13
5	6.997E+13	6.999E+13	7.050E+13	7.051E+13	7.134E+13	7.239E+13	7.705E+13	7.958E+13	8.298E+13	8.553E+13	8.569E+13
6	6.633E+13	6.641E+13	6.805E+13	6.572E+13	6.625E+13	6.720E+13	7.389E+13	7.552E+13	8.144E+13	8.561E+13	8.585E+13
7	5.261E+13	5.271E+13	5.475E+13	5.627E+13	5.698E+13	5.761E+13	5.945E+13	5.945E+13	6.510E+13	6.889E+13	6.915E+13
8	4.389E+13	4.389E+13	4.394E+13	4.507E+13	4.559E+13	4.617E+13	4.764E+13	4.894E+13	5.206E+13	5.473E+13	5.486E+13
9	4.066E+13	4.064E+13	4.041E+13	4.129E+13	4.145E+13	4.231E+13	4.375E+13	4.497E+13	4.778E+13	5.000E+13	4.984E+13
10	3.832E+13	3.825E+13	3.846E+13	3.922E+13	3.826E+13	4.019E+13	4.161E+13	4.130E+13	4.543E+13	4.744E+13	4.601E+13
11	3.556E+13	3.582E+13	3.697E+13	3.764E+13	3.500E+13	3.857E+13	3.997E+13	3.769E+13	4.363E+13	4.549E+13	4.210E+13
12	3.324E+13	3.335E+13	3.415E+13	3.472E+13	3.189E+13	3.558E+13	3.689E+13	3.435E+13	4.025E+13	4.192E+13	3.829E+13
13	3.131E+13	3.126E+13	2.962E+13	3.008E+13	2.992E+13	3.081E+13	3.195E+13	3.232E+13	3.484E+13	3.627E+13	3.585E+13
14	2.969E+13	2.956E+13	2.752E+13	2.793E+13	2.861E+13	2.966E+13	3.089E+13	3.233E+13	3.233E+13	3.364E+13	3.414E+13
15	2.613E+13	2.602E+13	2.450E+13	2.485E+13	2.533E+13	2.545E+13	2.638E+13	2.749E+13	2.875E+13	2.991E+13	3.025E+13
16	5.200E+12	5.192E+12	5.092E+12	5.158E+12	5.223E+12	5.280E+12	5.478E+12	5.707E+12	5.946E+12	6.152E+12	6.174E+12
17	7.275E+11	7.270E+11	7.201E+11	7.294E+11	7.378E+11	7.467E+11	7.754E+11	8.074E+11	8.400E+11	8.666E+11	8.686E+11
18	2.353E+11	2.352E+11	2.333E+11	2.363E+11	2.390E+11	2.419E+11	2.513E+11	2.616E+11	2.721E+11	2.806E+11	2.812E+11
19	7.129E+09	7.127E+09	7.101E+09	7.224E+09	7.323E+09	7.425E+09	7.716E+09	8.023E+09	8.330E+09	8.572E+09	8.588E+09

PLANE NUMBER 5

1	1.078E+14	1.078E+14	1.079E+14	1.102E+14	1.116E+14	1.135E+14	1.178E+14	1.202E+14	1.225E+14	1.235E+14	1.236E+14
2	1.013E+14	1.013E+14	1.014E+14	1.048E+14	1.087E+14	1.114E+14	1.166E+14	1.197E+14	1.225E+14	1.242E+14	1.242E+14
3	1.021E+14	1.021E+14	1.023E+14	1.046E+14	1.066E+14	1.091E+14	1.148E+14	1.184E+14	1.220E+14	1.242E+14	1.244E+14
4	1.017E+14	1.017E+14	1.021E+14	1.034E+14	1.049E+14	1.068E+14	1.133E+14	1.170E+14	1.214E+14	1.243E+14	1.245E+14
5	1.009E+14	1.009E+14	1.018E+14	1.016E+14	1.029E+14	1.045E+14	1.120E+14	1.158E+14	1.210E+14	1.246E+14	1.248E+14
6	9.490E+13	9.502E+13	9.740E+13	9.368E+13	9.451E+13	9.597E+13	1.064E+14	1.089E+14	1.177E+14	1.234E+14	1.237E+14
7	7.473E+13	7.498E+13	7.777E+13	7.955E+13	8.059E+13	8.159E+13	8.493E+13	8.508E+13	9.325E+13	9.824E+13	9.859E+13
8	6.216E+13	6.216E+13	6.218E+13	6.349E+13	6.425E+13	6.515E+13	6.779E+13	6.983E+13	7.425E+13	7.772E+13	7.791E+13
9	5.752E+13	5.749E+13	5.711E+13	5.810E+13	5.837E+13	5.964E+13	6.217E+13	6.409E+13	6.805E+13	7.093E+13	7.070E+13
10	5.416E+13	5.406E+13	5.432E+13	5.516E+13	5.384E+13	5.662E+13	5.908E+13	5.881E+13	6.465E+13	6.725E+13	6.522E+13
11	5.021E+13	5.059E+13	5.219E+13	5.292E+13	4.921E+13	5.432E+13	5.673E+13	5.361E+13	6.207E+13	6.446E+13	5.962E+13
12	4.688E+13	4.705E+13	4.818E+13	4.878E+13	4.480E+13	5.007E+13	5.232E+13	4.879E+13	5.722E+13	5.936E+13	5.417E+13
13	4.412E+13	4.405E+13	4.174E+13	4.221E+13	4.199E+13	4.332E+13	4.526E+13	4.585E+13	4.946E+13	5.129E+13	5.066E+13
14	4.182E+13	4.163E+13	3.874E+13	3.916E+13	4.003E+13	4.018E+13	4.196E+13	4.379E+13	4.584E+13	4.753E+13	4.822E+13
15	3.677E+13	3.661E+13	3.445E+13	3.482E+13	3.550E+13	3.572E+13	3.729E+13	3.892E+13	4.072E+13	4.221E+13	4.268E+13
16	7.179E+12	7.169E+12	7.029E+12	7.105E+12	7.198E+12	7.283E+12	7.593E+12	7.920E+12	8.255E+12	8.521E+12	8.550E+12
17	9.867E+11	9.861E+11	9.768E+11	9.884E+11	1.000E+12	1.013E+12	1.056E+12	1.100E+12	1.145E+12	1.179E+12	1.182E+12
18	3.179E+11	3.178E+11	3.152E+11	3.190E+11	3.228E+11	3.270E+11	3.407E+11	3.550E+11	3.693E+11	3.803E+11	3.811E+11
19	9.123E+09	9.121E+09	9.089E+09	9.267E+09	9.413E+09	9.555E+09	9.942E+09	1.034E+10	1.073E+10	1.103E+10	1.106E+10

PLANE NUMBER 6

1	1.463E+14	1.463E+14	1.466E+14	1.505E+14	1.528E+14	1.561E+14	1.635E+14	1.675E+14	1.711E+14	1.728E+14	1.729E+14
2	1.371E+14	1.371E+14	1.374E+14	1.430E+14	1.493E+14	1.539E+14	1.629E+14	1.677E+14	1.723E+14	1.746E+14	1.747E+14
3	1.380E+14	1.380E+14	1.384E+14	1.424E+14	1.465E+14	1.511E+14	1.610E+14	1.664E+14	1.720E+14	1.750E+14	1.752E+14
4	1.376E+14	1.376E+14	1.386E+14	1.408E+14	1.436E+14	1.472E+14	1.582E+14	1.631E+14	1.702E+14	1.738E+14	1.739E+14

Information Processing Center

Information Processing Center

Information Processing Center

Information Processing Center

5	1.364E+14	1.365E+14	1.388E+14	1.379E+14	1.401E+14	1.431E+14	1.559E+14	1.600E+14	1.690E+14	1.732E+14	1.735E+14
6	1.260E+14	1.261E+14	1.300E+14	1.229E+14	1.240E+14	1.263E+14	1.434E+14	1.461E+14	1.588E+14	1.647E+14	1.651E+14
7	9.805E+13	9.827E+13	1.027E+14	1.037E+14	1.051E+14	1.066E+14	1.130E+14	1.124E+14	1.240E+14	1.290E+14	1.293E+14
8	8.122E+13	8.123E+13	8.157E+13	8.250E+13	8.363E+13	8.483E+13	8.952E+13	8.996E+13	9.799E+13	1.015E+14	1.018E+14
9	7.508E+13	7.501E+13	7.416E+13	7.483E+13	7.528E+13	7.694E+13	8.122E+13	8.437E+13	8.884E+13	9.174E+13	9.150E+13
10	7.058E+13	7.041E+13	7.038E+13	7.091E+13	6.930E+13	7.292E+13	7.700E+13	7.730E+13	8.420E+13	8.681E+13	8.423E+13
11	6.512E+13	6.559E+13	6.752E+13	6.795E+13	6.318E+13	6.988E+13	7.381E+13	7.010E+13	8.070E+13	8.310E+13	7.679E+13
12	6.049E+13	6.072E+13	6.218E+13	6.252E+13	5.733E+13	6.428E+13	6.789E+13	6.344E+13	7.421E+13	7.636E+13	6.953E+13
13	5.671E+13	5.662E+13	5.364E+13	5.391E+13	5.359E+13	5.541E+13	5.846E+13	5.932E+13	6.386E+13	6.573E+13	6.481E+13
14	5.362E+13	5.338E+13	4.963E+13	4.990E+13	5.101E+13	5.127E+13	5.404E+13	5.652E+13	5.900E+13	6.076E+13	6.161E+13
15	4.697E+13	4.677E+13	4.400E+13	4.424E+13	4.512E+13	4.546E+13	4.786E+13	5.005E+13	5.223E+13	5.381E+13	5.438E+13
16	8.806E+12	8.794E+12	8.630E+12	8.710E+12	8.828E+12	8.937E+12	9.356E+12	9.764E+12	1.017E+13	1.046E+13	1.050E+13
17	1.175E+12	1.174E+12	1.164E+12	1.179E+12	1.194E+12	1.209E+12	1.263E+12	1.317E+12	1.369E+12	1.408E+12	1.411E+12
18	3.763E+11	3.762E+11	3.735E+11	3.783E+11	3.831E+11	3.882E+11	4.053E+11	4.223E+11	4.390E+11	4.514E+11	4.523E+11
19	1.033E+10	1.033E+10	1.030E+10	1.056E+10	1.078E+10	1.096E+10	1.140E+10	1.183E+10	1.227E+10	1.262E+10	1.265E+10

PLANE NUMBER 7

1	1.654E+14	1.654E+14	1.656E+14	1.702E+14	1.728E+14	1.767E+14	1.852E+14	1.897E+14	1.939E+14	1.958E+14	1.959E+14
2	1.548E+14	1.548E+14	1.551E+14	1.616E+14	1.689E+14	1.742E+14	1.844E+14	1.900E+14	1.952E+14	1.978E+14	1.979E+14
3	1.558E+14	1.558E+14	1.562E+14	1.609E+14	1.656E+14	1.709E+14	1.823E+14	1.884E+14	1.947E+14	1.981E+14	1.983E+14
4	1.553E+14	1.554E+14	1.565E+14	1.589E+14	1.622E+14	1.663E+14	1.789E+14	1.846E+14	1.925E+14	1.965E+14	1.968E+14
5	1.542E+14	1.543E+14	1.570E+14	1.559E+14	1.583E+14	1.618E+14	1.765E+14	1.811E+14	1.913E+14	1.960E+14	1.963E+14
6	1.424E+14	1.426E+14	1.472E+14	1.386E+14	1.399E+14	1.425E+14	1.624E+14	1.652E+14	1.798E+14	1.862E+14	1.866E+14
7	1.111E+14	1.114E+14	1.172E+14	1.180E+14	1.195E+14	1.213E+14	1.289E+14	1.274E+14	1.413E+14	1.466E+14	1.470E+14
8	9.165E+13	9.171E+13	9.319E+13	9.404E+13	9.539E+13	9.669E+13	1.022E+14	1.040E+14	1.118E+14	1.156E+14	1.160E+14
9	8.452E+13	8.450E+13	8.430E+13	8.492E+13	8.555E+13	8.732E+13	9.233E+13	9.535E+13	1.009E+14	1.040E+14	1.039E+14
10	7.927E+13	7.914E+13	7.982E+13	8.031E+13	7.860E+13	8.258E+13	8.734E+13	8.728E+13	9.541E+13	9.823E+13	9.544E+13
11	7.292E+13	7.353E+13	7.644E+13	7.684E+13	7.147E+13	7.902E+13	8.359E+13	7.904E+13	9.130E+13	9.389E+13	8.678E+13
12	6.746E+13	6.775E+13	7.022E+13	7.054E+13	6.465E+13	7.253E+13	7.671E+13	7.137E+13	8.376E+13	8.609E+13	7.832E+13
13	6.304E+13	6.297E+13	6.034E+13	6.062E+13	6.026E+13	6.231E+13	6.582E+13	6.660E+13	7.182E+13	7.384E+13	7.281E+13
14	5.952E+13	5.929E+13	5.568E+13	5.597E+13	5.728E+13	5.752E+13	6.068E+13	6.340E+13	6.618E+13	6.809E+13	6.910E+13
15	5.204E+13	5.185E+13	4.924E+13	4.952E+13	5.055E+13	5.088E+13	5.362E+13	5.604E+13	5.846E+13	6.016E+13	6.086E+13
16	9.595E+12	9.585E+12	9.439E+12	9.535E+12	9.669E+12	9.786E+12	1.025E+13	1.070E+13	1.113E+13	1.144E+13	1.149E+13
17	1.263E+12	1.262E+12	1.253E+12	1.270E+12	1.287E+12	1.305E+12	1.363E+12	1.421E+12	1.476E+12	1.517E+12	1.520E+12
18	4.031E+11	4.029E+11	4.006E+11	4.064E+11	4.119E+11	4.176E+11	4.361E+11	4.543E+11	4.717E+11	4.849E+11	4.859E+11
19	1.084E+10	1.084E+10	1.082E+10	1.115E+10	1.144E+10	1.163E+10	1.209E+10	1.254E+10	1.299E+10	1.337E+10	1.340E+10

PLANE NUMBER 8

1	1.759E+14	1.759E+14	1.762E+14	1.811E+14	1.839E+14	1.880E+14	1.970E+14	2.019E+14	2.062E+14	2.083E+14	2.084E+14
2	1.648E+14	1.648E+14	1.652E+14	1.721E+14	1.798E+14	1.855E+14	1.964E+14	2.022E+14	2.076E+14	2.104E+14	2.105E+14
3	1.660E+14	1.660E+14	1.665E+14	1.714E+14	1.765E+14	1.822E+14	1.942E+14	2.006E+14	2.073E+14	2.108E+14	2.110E+14
4	1.657E+14	1.658E+14	1.669E+14	1.695E+14	1.730E+14	1.774E+14	1.908E+14	1.967E+14	2.051E+14	2.092E+14	2.094E+14
5	1.647E+14	1.649E+14	1.679E+14	1.665E+14	1.691E+14	1.727E+14	1.884E+14	1.931E+14	2.039E+14	2.088E+14	2.091E+14
6	1.529E+14	1.531E+14	1.583E+14	1.484E+14	1.498E+14	1.525E+14	1.742E+14	1.767E+14	1.926E+14	1.992E+14	1.996E+14
7	1.202E+14	1.206E+14	1.286E+14	1.290E+14	1.305E+14	1.325E+14	1.408E+14	1.374E+14	1.541E+14	1.598E+14	1.601E+14
8	9.838E+13	9.856E+13	1.028E+14	1.036E+14	1.051E+14	1.064E+14	1.124E+14	1.120E+14	1.226E+14	1.268E+14	1.274E+14
9	9.017E+13	9.027E+13	9.133E+13	9.204E+13	9.342E+13	9.456E+13	9.976E+13	1.024E+14	1.088E+14	1.123E+14	1.130E+14
10	8.250E+13	8.290E+13	8.556E+13	8.619E+13	8.537E+13	8.855E+13	9.342E+13	9.356E+13	1.019E+14	1.050E+14	1.032E+14
11	7.467E+13	7.542E+13	8.121E+13	8.177E+13	7.716E+13	8.402E+13	8.864E+13	8.447E+13	9.663E+13	9.952E+13	9.325E+13
12	6.746E+13	6.785E+13	7.351E+13	7.402E+13	6.939E+13	7.604E+13	8.021E+13	7.604E+13	8.741E+13	8.998E+13	8.368E+13
13	6.299E+13	6.301E+13	6.347E+13	6.397E+13	6.440E+13	6.570E+13	6.920E+13	7.079E+13	7.537E+13	7.763E+13	7.748E+13
14	5.992E+13	5.985E+13	5.861E+13	5.912E+13	6.110E+13	6.072E+13	6.387E+13	6.730E+13	6.954E+13	7.166E+13	7.340E+13
15	5.291E+13	5.283E+13	5.184E+13	5.233E+13	5.379E+13	5.374E+13	5.647E+13	5.939E+13	6.146E+13	6.336E+13	6.449E+13
16	9.919E+12	9.913E+12	9.833E+12	9.957E+12	1.011E+13	1.022E+13	1.069E+13	1.117E+13	1.159E+13	1.192E+13	1.198E+13
17	1.297E+12	1.297E+12	1.291E+12	1.312E+12	1.332E+12	1.350E+12	1.410E+12	1.468E+12	1.523E+12	1.566E+12	1.570E+12
18	4.133E+11	4.132E+11	4.116E+11	4.188E+11	4.252E+11	4.313E+11	4.502E+11	4.687E+11	4.860E+11	4.996E+11	5.008E+11
19	1.099E+10	1.099E+10	1.097E+10	1.141E+10	1.160E+10	1.202E+10	1.247E+10	1.290E+10	1.334E+10	1.374E+10	1.379E+10

PLANE NUMBER 9

1	1.761E+14	1.761E+14	1.764E+14	1.814E+14	1.843E+14	1.885E+14	1.976E+14	2.023E+14	2.066E+14	2.085E+14	2.087E+14
---	-----------	-----------	-----------	-----------	-----------	-----------	-----------	-----------	-----------	-----------	-----------

Information Processing Center

Information Processing Center

Information Processing Center

Information Processing Center

2	1.652E+14	1.653E+14	1.656E+14	1.727E+14	1.805E+14	1.864E+14	1.972E+14	2.028E+14	2.080E+14	2.106E+14	2.107E+14
3	1.667E+14	1.668E+14	1.672E+14	1.723E+14	1.776E+14	1.834E+14	1.952E+14	2.013E+14	2.077E+14	2.110E+14	2.112E+14
4	1.668E+14	1.669E+14	1.681E+14	1.707E+14	1.743E+14	1.787E+14	1.918E+14	1.974E+14	2.055E+14	2.094E+14	2.096E+14
5	1.662E+14	1.664E+14	1.697E+14	1.682E+14	1.707E+14	1.743E+14	1.896E+14	1.939E+14	2.045E+14	2.091E+14	2.094E+14
6	1.552E+14	1.555E+14	1.612E+14	1.501E+14	1.512E+14	1.539E+14	1.762E+14	1.780E+14	1.940E+14	2.003E+14	2.006E+14
7	1.235E+14	1.240E+14	1.339E+14	1.339E+14	1.353E+14	1.372E+14	1.454E+14	1.400E+14	1.585E+14	1.641E+14	1.645E+14
8	1.010E+14	1.013E+14	1.081E+14	1.088E+14	1.102E+14	1.115E+14	1.172E+14	1.142E+14	1.274E+14	1.316E+14	1.323E+14
9	9.248E+13	9.270E+13	9.533E+13	9.596E+13	9.741E+13	9.836E+13	1.033E+14	1.044E+14	1.122E+14	1.158E+14	1.167E+14
10	8.443E+13	8.501E+13	8.898E+13	8.957E+13	8.875E+13	9.182E+13	9.646E+13	9.529E+13	1.048E+14	1.080E+14	1.063E+14
11	7.614E+13	7.708E+13	8.424E+13	8.478E+13	7.990E+13	8.692E+13	9.131E+13	8.589E+13	9.916E+13	1.021E+14	9.567E+13
12	6.841E+13	6.890E+13	7.597E+13	7.649E+13	7.151E+13	7.841E+13	8.235E+13	7.712E+13	8.940E+13	9.205E+13	8.546E+13
13	6.356E+13	6.363E+13	6.518E+13	6.573E+13	6.609E+13	6.737E+13	7.065E+13	7.161E+13	7.666E+13	7.900E+13	7.880E+13
14	6.035E+13	6.034E+13	5.992E+13	6.051E+13	6.257E+13	6.202E+13	6.495E+13	6.801E+13	7.045E+13	7.266E+13	7.450E+13
15	5.314E+13	5.311E+13	5.278E+13	5.336E+13	5.489E+13	5.469E+13	5.721E+13	5.989E+13	6.204E+13	6.402E+13	6.524E+13
16	9.727E+12	9.725E+12	9.692E+12	9.851E+12	1.001E+13	1.011E+13	1.055E+13	1.100E+13	1.139E+13	1.173E+13	1.179E+13
17	1.257E+12	1.257E+12	1.254E+12	1.284E+12	1.309E+12	1.329E+12	1.385E+12	1.441E+12	1.489E+12	1.532E+12	1.537E+12
18	3.998E+11	3.998E+11	3.990E+11	4.094E+11	4.184E+11	4.249E+11	4.428E+11	4.599E+11	4.755E+11	4.890E+11	4.905E+11
19	1.063E+10	1.063E+10	1.063E+10	1.126E+10	1.194E+10	1.214E+10	1.254E+10	1.290E+10	1.331E+10	1.374E+10	1.383E+10

PLANE NUMBER 10

1	1.408E+14	1.408E+14	1.411E+14	1.460E+14	1.489E+14	1.535E+14	1.622E+14	1.660E+14	1.695E+14	1.710E+14	1.711E+14
2	1.318E+14	1.318E+14	1.321E+14	1.390E+14	1.464E+14	1.527E+14	1.621E+14	1.663E+14	1.703E+14	1.723E+14	1.724E+14
3	1.329E+14	1.329E+14	1.334E+14	1.387E+14	1.446E+14	1.505E+14	1.601E+14	1.646E+14	1.694E+14	1.718E+14	1.720E+14
4	1.334E+14	1.335E+14	1.347E+14	1.375E+14	1.411E+14	1.451E+14	1.557E+14	1.592E+14	1.658E+14	1.687E+14	1.688E+14
5	1.334E+14	1.335E+14	1.374E+14	1.362E+14	1.384E+14	1.414E+14	1.536E+14	1.554E+14	1.644E+14	1.678E+14	1.680E+14
6	1.240E+14	1.243E+14	1.304E+14	1.187E+14	1.194E+14	1.215E+14	1.411E+14	1.404E+14	1.541E+14	1.585E+14	1.588E+14
7	9.852E+13	9.902E+13	1.093E+14	1.093E+14	1.103E+14	1.116E+14	1.175E+14	1.103E+14	1.272E+14	1.314E+14	1.316E+14
8	8.032E+13	8.067E+13	8.872E+13	8.941E+13	9.048E+13	9.127E+13	9.519E+13	8.974E+13	1.029E+14	1.063E+14	1.067E+14
9	7.346E+13	7.373E+13	7.725E+13	7.795E+13	7.904E+13	7.960E+13	8.295E+13	8.202E+13	8.966E+13	9.254E+13	9.318E+13
10	6.712E+13	6.770E+13	7.179E+13	7.246E+13	7.175E+13	7.401E+13	7.712E+13	7.493E+13	8.335E+13	8.598E+13	8.461E+13
11	6.071E+13	6.153E+13	6.777E+13	6.841E+13	6.444E+13	6.988E+13	7.282E+13	6.779E+13	7.871E+13	8.116E+13	7.607E+13
12	5.483E+13	5.522E+13	6.080E+13	6.143E+13	5.778E+13	6.276E+13	6.536E+13	6.124E+13	7.063E+13	7.286E+13	6.802E+13
13	5.117E+13	5.120E+13	5.178E+13	5.245E+13	5.340E+13	5.359E+13	5.569E+13	5.718E+13	6.017E+13	6.219E+13	6.280E+13
14	4.860E+13	4.853E+13	4.739E+13	4.811E+13	5.049E+13	4.916E+13	5.100E+13	5.433E+13	5.508E+13	5.703E+13	5.931E+13
15	4.275E+13	4.267E+13	4.162E+13	4.232E+13	4.416E+13	4.325E+13	4.482E+13	4.784E+13	4.839E+13	5.016E+13	5.181E+13
16	7.876E+12	7.871E+12	7.796E+12	7.995E+12	8.185E+12	8.256E+12	8.587E+12	9.005E+12	9.204E+12	9.488E+12	9.567E+12
17	1.044E+12	1.044E+12	1.040E+12	1.087E+12	1.132E+12	1.153E+12	1.198E+12	1.241E+12	1.274E+12	1.311E+12	1.318E+12
18	3.340E+11	3.339E+11	3.332E+11	3.502E+11	3.711E+11	3.766E+11	3.909E+11	4.027E+11	4.144E+11	4.269E+11	4.303E+11
19	9.352E+09	9.352E+09	9.364E+09	1.029E+10	1.162E+10	1.166E+10	1.192E+10	1.213E+10	1.249E+10	1.295E+10	1.316E+10

PLANE NUMBER 11

1	1.186E+14	1.186E+14	1.188E+14	1.230E+14	1.255E+14	1.295E+14	1.366E+14	1.397E+14	1.423E+14	1.435E+14	1.436E+14
2	1.108E+14	1.108E+14	1.111E+14	1.170E+14	1.234E+14	1.290E+14	1.366E+14	1.399E+14	1.429E+14	1.444E+14	1.445E+14
3	1.120E+14	1.121E+14	1.125E+14	1.169E+14	1.223E+14	1.273E+14	1.349E+14	1.383E+14	1.421E+14	1.440E+14	1.441E+14
4	1.123E+14	1.124E+14	1.135E+14	1.159E+14	1.189E+14	1.222E+14	1.305E+14	1.331E+14	1.384E+14	1.406E+14	1.408E+14
5	1.126E+14	1.127E+14	1.165E+14	1.156E+14	1.173E+14	1.197E+14	1.294E+14	1.301E+14	1.379E+14	1.405E+14	1.407E+14
6	1.045E+14	1.047E+14	1.104E+14	1.001E+14	1.006E+14	1.023E+14	1.187E+14	1.174E+14	1.290E+14	1.325E+14	1.327E+14
7	8.290E+13	8.334E+13	9.257E+13	9.254E+13	9.324E+13	9.423E+13	9.883E+13	9.223E+13	1.068E+14	1.101E+14	1.103E+14
8	6.717E+13	6.751E+13	7.535E+13	7.600E+13	7.643E+13	7.738E+13	8.040E+13	7.468E+13	8.673E+13	8.956E+13	8.945E+13
9	6.097E+13	6.124E+13	6.512E+13	6.578E+13	6.554E+13	6.702E+13	6.959E+13	6.778E+13	7.508E+13	7.754E+13	7.673E+13
10	5.664E+13	5.688E+13	6.051E+13	6.118E+13	6.027E+13	6.234E+13	6.471E+13	6.299E+13	6.981E+13	7.211E+13	7.053E+13
11	5.344E+13	5.357E+13	5.618E+13	5.686E+13	5.644E+13	5.795E+13	6.011E+13	5.944E+13	6.484E+13	6.703E+13	6.602E+13
12	5.008E+13	5.009E+13	4.996E+13	5.069E+13	5.246E+13	5.166E+13	5.350E+13	5.573E+13	5.769E+13	5.975E+13	6.132E+13
13	4.648E+13	4.637E+13	4.303E+13	4.383E+13	4.825E+13	4.469E+13	4.613E+13	5.176E+13	4.973E+13	5.166E+13	5.633E+13
14	4.353E+13	4.330E+13	3.970E+13	4.053E+13	4.492E+13	4.133E+13	4.260E+13	4.851E+13	4.591E+13	4.777E+13	5.238E+13
15	3.771E+13	3.753E+13	3.511E+13	3.590E+13	3.870E+13	3.663E+13	3.772E+13	4.208E+13	4.064E+13	4.232E+13	4.508E+13
16	6.963E+12	6.956E+12	6.856E+12	7.078E+12	7.291E+12	7.352E+12	7.645E+12	8.051E+12	8.149E+12	8.399E+12	8.489E+12
17	9.415E+11	9.412E+11	9.377E+11	9.938E+11	1.055E+12	1.075E+12	1.116E+12	1.152E+12	1.178E+12	1.213E+12	1.222E+12
18	3.026E+11	3.026E+11	3.019E+11	3.230E+11	3.563E+11	3.586E+11	3.709E+11	3.787E+11	3.899E+11	4.022E+11	4.080E+11
19	8.745E+09	8.746E+09	8.763E+09	9.825E+09	1.153E+10	1.144E+10	1.164E+10	1.177E+10	1.210E+10	1.259E+10	1.287E+10

PLANE NUMBER 12

Information Processing Center

Information Processing Center

	1	2	3	4	5	6	7	8	9	10	11
1	9.439E+13	9.440E+13	9.450E+13	9.645E+13	9.734E+13	9.813E+13	1.008E+14	1.025E+14	1.041E+14	1.049E+14	1.049E+14
2	8.814E+13	8.815E+13	8.830E+13	9.150E+13	9.488E+13	9.648E+13	1.004E+14	1.027E+14	1.048E+14	1.059E+14	1.059E+14
3	8.986E+13	8.987E+13	9.001E+13	9.239E+13	9.347E+13	9.516E+13	9.981E+13	1.025E+14	1.050E+14	1.063E+14	1.064E+14
4	8.934E+13	8.935E+13	8.942E+13	9.089E+13	9.225E+13	9.394E+13	9.912E+13	1.021E+14	1.049E+14	1.064E+14	1.065E+14
5	8.852E+13	8.849E+13	8.810E+13	8.837E+13	8.954E+13	9.108E+13	9.679E+13	1.007E+14	1.030E+14	1.047E+14	1.048E+14
6	8.192E+13	8.192E+13	8.185E+13	7.974E+13	8.023E+13	8.138E+13	8.774E+13	9.161E+13	9.513E+13	9.743E+13	9.756E+13
7	6.550E+13	6.563E+13	6.742E+13	6.744E+13	6.786E+13	6.853E+13	7.175E+13	7.259E+13	7.765E+13	7.998E+13	8.010E+13
8	5.376E+13	5.386E+13	5.518E+13	5.563E+13	5.598E+13	5.654E+13	5.878E+13	5.958E+13	6.348E+13	6.552E+13	6.555E+13
9	4.970E+13	4.979E+13	5.101E+13	5.157E+13	5.185E+13	5.243E+13	5.439E+13	5.510E+13	5.869E+13	6.063E+13	6.060E+13
10	4.707E+13	4.713E+13	4.810E+13	4.870E+13	4.897E+13	4.952E+13	5.132E+13	5.220E+13	5.536E+13	5.723E+13	5.718E+13
11	4.500E+13	4.500E+13	4.504E+13	4.567E+13	4.667E+13	4.645E+13	4.808E+13	4.992E+13	5.184E+13	5.366E+13	5.445E+13
12	4.262E+13	4.255E+13	4.055E+13	4.124E+13	4.401E+13	4.195E+13	4.333E+13	4.731E+13	4.669E+13	4.843E+13	5.128E+13
13	3.976E+13	3.963E+13	3.558E+13	3.634E+13	4.083E+13	3.698E+13	3.808E+13	4.418E+13	4.099E+13	4.265E+13	4.750E+13
14	3.734E+13	3.709E+13	3.334E+13	3.412E+13	3.818E+13	3.474E+13	3.573E+13	4.151E+13	3.844E+13	4.005E+13	4.437E+13
15	3.245E+13	3.227E+13	2.984E+13	3.058E+13	3.310E+13	3.116E+13	3.203E+13	3.615E+13	3.444E+13	3.589E+13	3.841E+13
16	6.213E+12	6.206E+12	6.111E+12	6.353E+12	6.577E+12	6.658E+12	6.934E+12	7.306E+12	7.344E+12	7.558E+12	7.637E+12
17	8.605E+11	8.603E+11	8.573E+11	9.227E+11	1.005E+12	1.023E+12	1.060E+12	1.089E+12	1.110E+12	1.143E+12	1.155E+12
18	2.779E+11	2.778E+11	2.773E+11	3.027E+11	3.567E+11	3.515E+11	3.619E+11	3.642E+11	3.769E+11	3.896E+11	4.001E+11
19	8.263E+09	8.264E+09	8.285E+09	9.455E+09	1.154E+10	1.129E+10	1.143E+10	1.150E+10	1.182E+10	1.232E+10	1.268E+10

PLANE NUMBER 13

	1	2	3	4	5	6	7	8	9	10	11
1	8.189E+13	8.189E+13	8.197E+13	8.341E+13	8.417E+13	8.495E+13	8.697E+13	8.833E+13	8.960E+13	9.022E+13	9.025E+13
2	7.753E+13	7.754E+13	7.765E+13	7.985E+13	8.207E+13	8.360E+13	8.667E+13	8.853E+13	9.026E+13	9.112E+13	9.117E+13
3	7.845E+13	7.846E+13	7.855E+13	8.029E+13	8.136E+13	8.264E+13	8.626E+13	8.852E+13	9.062E+13	9.170E+13	9.177E+13
4	7.870E+13	7.870E+13	7.874E+13	7.992E+13	8.098E+13	8.226E+13	8.631E+13	8.889E+13	9.119E+13	9.244E+13	9.251E+13
5	7.660E+13	7.659E+13	7.644E+13	7.685E+13	7.776E+13	7.895E+13	8.333E+13	8.635E+13	8.857E+13	8.996E+13	9.004E+13
6	7.013E+13	7.013E+13	7.010E+13	6.871E+13	6.910E+13	6.997E+13	7.486E+13	7.807E+13	8.110E+13	8.298E+13	8.308E+13
7	5.606E+13	5.614E+13	5.724E+13	5.729E+13	5.755E+13	5.805E+13	6.071E+13	6.188E+13	6.580E+13	6.773E+13	6.783E+13
8	4.691E+13	4.697E+13	4.771E+13	4.811E+13	4.845E+13	4.879E+13	5.071E+13	5.183E+13	5.481E+13	5.655E+13	5.670E+13
9	4.498E+13	4.502E+13	4.559E+13	4.611E+13	4.656E+13	4.681E+13	4.854E+13	4.977E+13	5.240E+13	5.413E+13	5.437E+13
10	4.274E+13	4.275E+13	4.289E+13	4.346E+13	4.415E+13	4.412E+13	4.570E+13	4.732E+13	4.930E+13	5.098E+13	5.150E+13
11	4.104E+13	4.100E+13	3.998E+13	4.058E+13	4.229E+13	4.121E+13	4.263E+13	4.545E+13	4.596E+13	4.750E+13	4.928E+13
12	3.911E+13	3.902E+13	3.616E+13	3.682E+13	4.017E+13	3.739E+13	3.860E+13	4.336E+13	4.157E+13	4.313E+13	4.675E+13
13	3.623E+13	3.609E+13	3.196E+13	3.268E+13	3.703E+13	3.320E+13	3.418E+13	4.020E+13	3.676E+13	3.824E+13	4.302E+13
14	3.411E+13	3.389E+13	3.059E+13	3.133E+13	3.476E+13	3.186E+13	3.276E+13	3.787E+13	3.521E+13	3.667E+13	4.033E+13
15	2.975E+13	2.960E+13	2.747E+13	2.818E+13	3.028E+13	2.869E+13	2.950E+13	3.311E+13	3.166E+13	3.298E+13	3.509E+13
16	5.850E+12	5.843E+12	5.756E+12	6.010E+12	6.239E+12	6.337E+12	6.608E+12	6.957E+12	6.970E+12	7.165E+12	7.234E+12
17	8.215E+11	8.213E+11	8.188E+11	8.892E+11	9.848E+11	1.000E+12	1.036E+12	1.060E+12	1.079E+12	1.112E+12	1.126E+12
18	2.660E+11	2.660E+11	2.656E+11	2.934E+11	3.624E+11	3.509E+11	3.602E+11	3.588E+11	3.732E+11	3.863E+11	4.004E+11
19	8.029E+09	8.031E+09	8.053E+09	9.276E+09	1.156E+10	1.122E+10	1.133E+10	1.137E+10	1.168E+10	1.219E+10	1.260E+10

PLANE NUMBER 14

	1	2	3	4	5	6	7	8	9	10	11
1	6.879E+13	6.880E+13	6.885E+13	6.977E+13	7.029E+13	7.083E+13	7.222E+13	7.319E+13	7.410E+13	7.454E+13	7.457E+13
2	6.694E+13	6.694E+13	6.700E+13	6.823E+13	6.904E+13	6.987E+13	7.192E+13	7.332E+13	7.464E+13	7.529E+13	7.533E+13
3	6.626E+13	6.627E+13	6.632E+13	6.744E+13	6.820E+13	6.905E+13	7.156E+13	7.332E+13	7.498E+13	7.581E+13	7.586E+13
4	6.606E+13	6.606E+13	6.610E+13	6.694E+13	6.765E+13	6.851E+13	7.131E+13	7.332E+13	7.517E+13	7.614E+13	7.619E+13
5	6.387E+13	6.386E+13	6.385E+13	6.431E+13	6.491E+13	6.571E+13	6.869E+13	7.090E+13	7.289E+13	7.396E+13	7.402E+13
6	5.751E+13	5.751E+13	5.750E+13	5.681E+13	5.705E+13	5.760E+13	6.095E+13	6.346E+13	6.599E+13	6.741E+13	6.748E+13
7	4.577E+13	4.580E+13	4.627E+13	4.633E+13	4.640E+13	4.668E+13	4.872E+13	5.015E+13	5.299E+13	5.448E+13	5.456E+13
8	3.899E+13	3.900E+13	3.915E+13	3.949E+13	3.973E+13	3.985E+13	4.140E+13	4.280E+13	4.484E+13	4.622E+13	4.648E+13
9	3.617E+13	3.616E+13	3.598E+13	3.642E+13	3.691E+13	3.680E+13	3.815E+13	3.977E+13	4.123E+13	4.257E+13	4.307E+13
10	3.481E+13	3.476E+13	3.412E+13	3.463E+13	3.550E+13	3.503E+13	3.625E+13	3.833E+13	3.910E+13	4.044E+13	4.134E+13
11	3.384E+13	3.376E+13	3.271E+13	3.326E+13	3.448E+13	3.367E+13	3.480E+13	3.731E+13	3.750E+13	3.893E+13	4.011E+13
12	3.221E+13	3.210E+13	3.044E+13	3.105E+13	3.277E+13	3.146E+13	3.246E+13	3.557E+13	3.492E+13	3.622E+13	3.804E+13
13	3.107E+13	3.092E+13	2.878E+13	2.945E+13	3.154E+13	2.987E+13	3.076E+13	3.438E+13	3.304E+13	3.434E+13	3.655E+13
14	2.976E+13	2.961E+13	2.760E+13	2.828E+13	3.020E+13	2.871E+13	2.955E+13	3.296E+13	3.171E+13	3.297E+13	3.496E+13
15	2.614E+13	2.602E+13	2.447E+13	2.512E+13	2.654E+13	2.555E+13	2.630E+13	2.903E+13	2.816E+13	2.928E+13	3.069E+13
16	5.371E+12	5.365E+12	5.290E+12	5.561E+12	5.799E+12	5.922E+12	6.189E+12	6.509E+12	6.487E+12	6.656E+12	6.710E+12
17	7.702E+11	7.701E+11	7.681E+11	8.455E+11	9.613E+11	9.722E+11	1.005E+12	1.024E+12	1.041E+12	1.073E+12	1.090E+12
18	2.503E+11	2.503E+11	2.501E+11	2.813E+11	3.785E+11	3.524E+11	3.602E+11	3.530E+11	3.704E+11	3.842E+11	4.003E+11

Information Processing Center

Information Processing Center

Information Processing Center

Information Processing Center

19 7.719E+09 7.721E+09 7.746E+09 9.037E+09 1.160E+10 1.113E+10 1.120E+10 1.120E+10 1.150E+10 1.203E+10 1.249E+10

PLANE NUMBER 15

	1	2	3	4	5	6	7	8	9	10	11
1	5.263E+13	5.263E+13	5.265E+13	5.310E+13	5.336E+13	5.363E+13	5.437E+13	5.493E+13	5.546E+13	5.572E+13	5.574E+13
2	5.147E+13	5.147E+13	5.150E+13	5.202E+13	5.235E+13	5.272E+13	5.378E+13	5.467E+13	5.551E+13	5.592E+13	5.595E+13
3	5.042E+13	5.042E+13	5.044E+13	5.095E+13	5.128E+13	5.167E+13	5.299E+13	5.416E+13	5.529E+13	5.584E+13	5.587E+13
4	4.953E+13	4.953E+13	4.955E+13	4.993E+13	5.018E+13	5.052E+13	5.197E+13	5.332E+13	5.467E+13	5.529E+13	5.532E+13
5	4.797E+13	4.798E+13	4.799E+13	4.820E+13	4.828E+13	4.854E+13	5.008E+13	5.161E+13	5.318E+13	5.388E+13	5.388E+13
6	4.241E+13	4.241E+13	4.241E+13	4.217E+13	4.191E+13	4.200E+13	4.378E+13	4.559E+13	4.767E+13	4.857E+13	4.853E+13
7	3.179E+13	3.180E+13	3.189E+13	3.196E+13	3.131E+13	3.129E+13	3.254E+13	3.375E+13	3.610E+13	3.702E+13	3.697E+13
8	2.731E+13	2.731E+13	2.724E+13	2.753E+13	2.709E+13	2.719E+13	2.824E+13	2.916E+13	3.087E+13	3.173E+13	3.179E+13
9	2.571E+13	2.569E+13	2.553E+13	2.590E+13	2.555E+13	2.569E+13	2.667E+13	2.751E+13	2.893E+13	2.977E+13	2.991E+13
10	2.480E+13	2.478E+13	2.452E+13	2.494E+13	2.471E+13	2.482E+13	2.575E+13	2.663E+13	2.782E+13	2.864E+13	2.885E+13
11	2.405E+13	2.403E+13	2.368E+13	2.414E+13	2.400E+13	2.409E+13	2.498E+13	2.590E+13	2.688E+13	2.770E+13	2.797E+13
12	2.309E+13	2.306E+13	2.260E+13	2.311E+13	2.310E+13	2.314E+13	2.398E+13	2.496E+13	2.570E+13	2.650E+13	2.685E+13
13	2.197E+13	2.193E+13	2.136E+13	2.191E+13	2.205E+13	2.203E+13	2.283E+13	2.388E+13	2.435E+13	2.513E+13	2.556E+13
14	2.071E+13	2.066E+13	2.008E+13	2.065E+13	2.085E+13	2.084E+13	2.159E+13	2.263E+13	2.294E+13	2.368E+13	2.411E+13
15	1.866E+13	1.862E+13	1.807E+13	1.865E+13	1.889E+13	1.893E+13	1.961E+13	2.056E+13	2.073E+13	2.140E+13	2.177E+13
16	4.417E+12	4.414E+12	4.372E+12	4.690E+12	4.968E+12	5.162E+12	5.431E+12	5.701E+12	5.888E+12	5.698E+12	5.718E+12
17	6.673E+11	6.672E+11	6.667E+11	7.606E+11	9.383E+11	9.304E+11	9.581E+11	9.623E+11	9.773E+11	1.009E+12	1.036E+12
18	2.188E+11	2.188E+11	2.190E+11	2.588E+11	4.426E+11	3.758E+11	3.796E+11	3.520E+11	3.832E+11	3.999E+11	4.441E+11
19	7.082E+09	7.084E+09	7.115E+09	8.542E+09	1.175E+10	1.094E+10	1.093E+10	1.085E+10	1.113E+10	1.168E+10	1.230E+10

Information Processing Center

Information Processing Center

PLANE NUMBER 16

	1	2	3	4	5	6	7	8	9	10	11
1	4.230E+13	4.229E+13	4.214E+13	4.243E+13	4.262E+13	4.282E+13	4.341E+13	4.402E+13	4.422E+13	4.437E+13	4.438E+13
2	4.156E+13	4.154E+13	4.120E+13	4.156E+13	4.179E+13	4.206E+13	4.288E+13	4.396E+13	4.419E+13	4.448E+13	4.449E+13
3	4.036E+13	4.036E+13	4.035E+13	4.074E+13	4.095E+13	4.122E+13	4.220E+13	4.313E+13	4.400E+13	4.441E+13	4.442E+13
4	4.005E+13	4.005E+13	4.006E+13	4.035E+13	4.022E+13	4.037E+13	4.145E+13	4.254E+13	4.380E+13	4.427E+13	4.418E+13
5	3.823E+13	3.823E+13	3.824E+13	3.838E+13	3.703E+13	3.697E+13	3.806E+13	3.923E+13	4.127E+13	4.175E+13	4.117E+13
6	3.365E+13	3.365E+13	3.366E+13	3.365E+13	3.209E+13	3.208E+13	3.337E+13	3.465E+13	3.710E+13	3.775E+13	3.704E+13
7	2.533E+13	2.533E+13	2.539E+13	2.568E+13	2.313E+13	2.325E+13	2.423E+13	2.480E+13	2.851E+13	2.917E+13	2.862E+13
8	2.194E+13	2.194E+13	2.189E+13	2.240E+13	2.053E+13	2.109E+13	2.201E+13	2.203E+13	2.461E+13	2.520E+13	2.490E+13
9	2.106E+13	2.106E+13	2.096E+13	2.153E+13	1.973E+13	2.074E+13	2.165E+13	2.119E+13	2.337E+13	2.394E+13	2.386E+13
10	2.025E+13	2.024E+13	2.010E+13	2.072E+13	1.910E+13	2.012E+13	2.101E+13	2.055E+13	2.244E+13	2.300E+13	2.297E+13
11	1.944E+13	1.943E+13	1.924E+13	1.990E+13	1.845E+13	1.945E+13	2.032E+13	1.989E+13	2.155E+13	2.207E+13	2.208E+13
12	1.859E+13	1.857E+13	1.834E+13	1.904E+13	1.780E+13	1.875E+13	1.958E+13	1.922E+13	2.062E+13	2.113E+13	2.116E+13
13	1.758E+13	1.756E+13	1.728E+13	1.801E+13	1.703E+13	1.790E+13	1.870E+13	1.844E+13	1.954E+13	2.002E+13	2.008E+13
14	1.656E+13	1.654E+13	1.624E+13	1.698E+13	1.625E+13	1.705E+13	1.782E+13	1.764E+13	1.847E+13	1.892E+13	1.898E+13
15	1.502E+13	1.500E+13	1.470E+13	1.544E+13	1.506E+13	1.577E+13	1.648E+13	1.641E+13	1.688E+13	1.728E+13	1.732E+13
16	3.812E+12	3.811E+12	3.787E+12	4.164E+12	4.536E+12	4.800E+12	5.082E+12	5.381E+12	5.120E+12	5.189E+12	5.182E+12
17	5.973E+11	5.973E+11	5.979E+11	7.061E+11	9.730E+11	9.256E+11	9.491E+11	9.379E+11	9.552E+11	9.877E+11	1.034E+12
18	1.971E+11	1.972E+11	1.976E+11	2.456E+11	6.129E+11	4.438E+11	4.432E+11	3.771E+11	4.400E+11	4.618E+11	5.591E+11
19	6.618E+09	6.620E+09	6.654E+09	8.164E+09	1.189E+10	1.075E+10	1.069E+10	1.058E+10	1.081E+10	1.138E+10	1.212E+10

Information Processing Center

Information Processing Center

PLANE NUMBER 17

	1	2	3	4	5	6	7	8	9	10	11
1	2.963E+13	2.963E+13	2.964E+13	2.984E+13	2.995E+13	3.008E+13	3.041E+13	3.067E+13	3.091E+13	3.102E+13	3.103E+13
2	2.892E+13	2.892E+13	2.892E+13	2.920E+13	2.936E+13	2.953E+13	3.002E+13	3.045E+13	3.084E+13	3.103E+13	3.104E+13
3	2.817E+13	2.817E+13	2.819E+13	2.853E+13	2.870E+13	2.889E+13	2.952E+13	3.008E+13	3.064E+13	3.091E+13	3.092E+13
4	2.745E+13	2.745E+13	2.747E+13	2.785E+13	2.796E+13	2.815E+13	2.887E+13	2.952E+13	3.027E+13	3.058E+13	3.058E+13
5	2.657E+13	2.658E+13	2.660E+13	2.706E+13	2.733E+13	2.754E+13	2.833E+13	2.900E+13	2.986E+13	3.022E+13	3.023E+13
6	2.340E+13	2.340E+13	2.343E+13	2.402E+13	2.437E+13	2.465E+13	2.559E+13	2.633E+13	2.753E+13	2.799E+13	2.802E+13
7	1.826E+13	1.827E+13	1.831E+13	1.916E+13	1.961E+13	1.998E+13	2.087E+13	2.102E+13	2.223E+13	2.266E+13	2.272E+13
8	1.592E+13	1.592E+13	1.593E+13	1.692E+13	1.783E+13	1.861E+13	1.950E+13	1.916E+13	1.951E+13	1.988E+13	2.005E+13
9	1.505E+13	1.505E+13	1.505E+13	1.608E+13	1.711E+13	1.794E+13	1.882E+13	1.843E+13	1.857E+13	1.890E+13	1.906E+13
10	1.442E+13	1.442E+13	1.440E+13	1.545E+13	1.657E+13	1.735E+13	1.821E+13	1.789E+13	1.792E+13	1.823E+13	1.835E+13
11	1.393E+13	1.393E+13	1.390E+13	1.497E+13	1.615E+13	1.689E+13	1.773E+13	1.747E+13	1.740E+13	1.770E+13	1.779E+13
12	1.335E+13	1.335E+13	1.331E+13	1.439E+13	1.567E+13	1.636E+13	1.719E+13	1.698E+13	1.679E+13	1.707E+13	1.714E+13
13	1.264E+13	1.264E+13	1.259E+13	1.367E+13	1.507E+13	1.571E+13	1.651E+13	1.638E+13	1.602E+13	1.628E+13	1.633E+13
14	1.193E+13	1.192E+13	1.186E+13	1.294E+13	1.449E+13	1.507E+13	1.585E+13	1.578E+13	1.524E+13	1.547E+13	1.550E+13
15	1.087E+13	1.087E+13	1.080E+13	1.185E+13	1.365E+13	1.416E+13	1.489E+13	1.492E+13	1.407E+13	1.428E+13	1.426E+13

Information Processing Center

Information Processing Center

16	3.089E+12	3.089E+12	3.086E+12	3.540E+12	4.310E+12	4.533E+12	4.829E+12	5.237E+12	4.764E+12	4.799E+12	4.817E+12
17	5.123E+11	5.124E+11	5.143E+11	6.401E+11	9.924E+11	9.261E+11	9.459E+11	9.127E+11	9.396E+11	9.731E+11	1.037E+12
18	1.707E+11	1.708E+11	1.716E+11	2.295E+11	7.005E+11	5.223E+11	5.177E+11	4.188E+11	5.094E+11	5.369E+11	6.460E+11
19	6.044E+09	6.047E+09	6.085E+09	7.691E+09	1.202E+10	1.053E+10	1.042E+10	1.022E+10	1.047E+10	1.105E+10	1.191E+10

PLANE NUMBER 18

	1	2	3	4	5	6	7	8	9	10	11
1	1.825E+13	1.825E+13	1.826E+13	1.847E+13	1.857E+13	1.868E+13	1.894E+13	1.908E+13	1.921E+13	1.927E+13	1.928E+13
2	1.776E+13	1.776E+13	1.778E+13	1.818E+13	1.839E+13	1.860E+13	1.903E+13	1.920E+13	1.935E+13	1.943E+13	1.943E+13
3	1.725E+13	1.725E+13	1.728E+13	1.791E+13	1.825E+13	1.857E+13	1.916E+13	1.933E+13	1.946E+13	1.956E+13	1.957E+13
4	1.677E+13	1.677E+13	1.681E+13	1.767E+13	1.823E+13	1.867E+13	1.938E+13	1.951E+13	1.955E+13	1.967E+13	1.971E+13
5	1.622E+13	1.623E+13	1.628E+13	1.738E+13	1.830E+13	1.880E+13	1.959E+13	1.969E+13	1.964E+13	1.979E+13	1.987E+13
6	1.429E+13	1.429E+13	1.436E+13	1.590E+13	1.738E+13	1.809E+13	1.903E+13	1.905E+13	1.881E+13	1.900E+13	1.915E+13
7	1.141E+13	1.141E+13	1.149E+13	1.341E+13	1.603E+13	1.672E+13	1.763E+13	1.736E+13	1.598E+13	1.608E+13	1.630E+13
8	9.959E+12	9.963E+12	1.003E+13	1.190E+13	1.478E+13	1.567E+13	1.656E+13	1.609E+13	1.433E+13	1.439E+13	1.464E+13
9	9.405E+12	9.410E+12	9.469E+12	1.130E+13	1.423E+13	1.507E+13	1.593E+13	1.555E+13	1.376E+13	1.380E+13	1.399E+13
10	9.017E+12	9.021E+12	9.076E+12	1.088E+13	1.383E+13	1.456E+13	1.540E+13	1.515E+13	1.335E+13	1.339E+13	1.354E+13
11	8.717E+12	8.721E+12	8.773E+12	1.054E+13	1.352E+13	1.417E+13	1.499E+13	1.484E+13	1.303E+13	1.305E+13	1.318E+13
12	8.369E+12	8.373E+12	8.421E+12	1.016E+13	1.315E+13	1.374E+13	1.454E+13	1.447E+13	1.264E+13	1.265E+13	1.275E+13
13	7.939E+12	7.942E+12	7.986E+12	9.668E+12	1.270E+13	1.321E+13	1.398E+13	1.402E+13	1.213E+13	1.214E+13	1.221E+13
14	7.507E+12	7.509E+12	7.549E+12	9.170E+12	1.224E+13	1.270E+13	1.344E+13	1.356E+13	1.160E+13	1.160E+13	1.165E+13
15	6.873E+12	6.875E+12	6.910E+12	8.430E+12	1.159E+13	1.196E+13	1.266E+13	1.288E+13	1.080E+13	1.079E+13	1.081E+13
16	2.205E+12	2.206E+12	2.218E+12	2.750E+12	3.787E+12	3.951E+12	4.235E+12	4.723E+12	4.058E+12	4.058E+12	4.106E+12
17	3.953E+11	3.956E+11	3.987E+11	5.361E+11	9.504E+11	8.509E+11	8.649E+11	8.116E+11	8.455E+11	8.780E+11	9.653E+11
18	1.335E+11	1.336E+11	1.348E+11	1.965E+11	6.896E+11	4.897E+11	4.899E+11	3.108E+11	4.763E+11	5.045E+11	6.233E+11
19	5.135E+09	5.138E+09	5.179E+09	6.819E+09	1.136E+10	9.909E+09	9.754E+09	9.179E+09	9.733E+09	1.031E+10	1.121E+10

PLANE NUMBER 19

	1	2	3	4	5	6	7	8	9	10	11
1	1.248E+13	1.248E+13	1.249E+13	1.266E+13	1.274E+13	1.283E+13	1.303E+13	1.312E+13	1.321E+13	1.325E+13	1.325E+13
2	1.212E+13	1.212E+13	1.214E+13	1.248E+13	1.265E+13	1.281E+13	1.315E+13	1.325E+13	1.333E+13	1.336E+13	1.336E+13
3	1.176E+13	1.176E+13	1.179E+13	1.230E+13	1.257E+13	1.282E+13	1.329E+13	1.337E+13	1.341E+13	1.345E+13	1.345E+13
4	1.142E+13	1.142E+13	1.146E+13	1.214E+13	1.252E+13	1.288E+13	1.344E+13	1.348E+13	1.346E+13	1.349E+13	1.350E+13
5	1.104E+13	1.104E+13	1.109E+13	1.195E+13	1.249E+13	1.296E+13	1.362E+13	1.360E+13	1.349E+13	1.352E+13	1.355E+13
6	9.730E+12	9.734E+12	9.798E+12	1.110E+13	1.205E+13	1.260E+13	1.366E+13	1.347E+13	1.307E+13	1.311E+13	1.316E+13
7	7.850E+12	7.855E+12	7.928E+12	9.547E+12	1.121E+13	1.223E+13	1.308E+13	1.261E+13	1.139E+13	1.136E+13	1.145E+13
8	6.871E+12	6.876E+12	6.943E+12	8.522E+12	1.033E+13	1.131E+13	1.210E+13	1.170E+13	1.035E+13	1.030E+13	1.038E+13
9	6.496E+12	6.501E+12	6.565E+12	8.115E+12	9.957E+12	1.088E+13	1.164E+13	1.131E+13	9.944E+12	9.890E+12	9.953E+12
10	6.233E+12	6.238E+12	6.299E+12	7.821E+12	9.677E+12	1.055E+13	1.129E+13	1.102E+13	9.645E+12	9.588E+12	9.643E+12
11	6.031E+12	6.035E+12	6.094E+12	7.591E+12	9.454E+12	1.030E+13	1.102E+13	1.079E+13	9.409E+12	9.350E+12	9.399E+12
12	5.796E+12	5.800E+12	5.857E+12	7.320E+12	9.186E+12	9.993E+12	1.069E+13	1.051E+13	9.125E+12	9.064E+12	9.109E+12
13	5.505E+12	5.509E+12	5.564E+12	6.979E+12	8.841E+12	9.601E+12	1.027E+13	1.014E+13	8.761E+12	8.699E+12	8.739E+12
14	5.214E+12	5.218E+12	5.269E+12	6.629E+12	8.472E+12	9.186E+12	9.821E+12	9.745E+12	8.377E+12	8.316E+12	8.351E+12
15	4.788E+12	4.791E+12	4.838E+12	6.109E+12	7.902E+12	8.547E+12	9.137E+12	9.127E+12	7.795E+12	7.736E+12	7.767E+12
16	1.656E+12	1.657E+12	1.672E+12	2.143E+12	2.805E+12	3.060E+12	3.296E+12	3.587E+12	3.125E+12	3.114E+12	3.150E+12
17	3.127E+11	3.130E+11	3.163E+11	4.37E+11	7.321E+11	6.813E+11	6.938E+11	6.548E+11	6.741E+11	6.999E+11	7.618E+11
18	1.066E+11	1.066E+11	1.078E+11	1.580E+11	4.007E+11	3.102E+11	3.072E+11	2.379E+11	2.979E+11	3.148E+11	3.765E+11
19	4.352E+09	4.354E+09	4.394E+09	5.914E+09	9.800E+09	8.867E+09	8.716E+09	7.989E+09	8.672E+09	9.195E+09	9.966E+09

PLANE NUMBER 20

	1	2	3	4	5	6	7	8	9	10	11
1	6.152E+11	6.153E+11	6.156E+11	6.216E+11	6.246E+11	6.278E+11	6.353E+11	6.393E+11	6.429E+11	6.444E+11	6.445E+11
2	5.994E+11	5.995E+11	6.001E+11	6.117E+11	6.174E+11	6.231E+11	6.356E+11	6.401E+11	6.440E+11	6.454E+11	6.455E+11
3	5.833E+11	5.834E+11	5.843E+11	6.015E+11	6.098E+11	6.181E+11	6.352E+11	6.398E+11	6.433E+11	6.445E+11	6.445E+11
4	5.684E+11	5.685E+11	5.697E+11	5.917E+11	6.024E+11	6.130E+11	6.337E+11	6.375E+11	6.401E+11	6.408E+11	6.408E+11
5	5.518E+11	5.519E+11	5.533E+11	5.807E+11	5.940E+11	6.071E+11	6.314E+11	6.343E+11	6.355E+11	6.357E+11	6.357E+11
6	4.942E+11	4.944E+11	4.967E+11	5.404E+11	5.624E+11	5.834E+11	6.179E+11	6.160E+11	6.112E+11	6.095E+11	6.095E+11
7	4.112E+11	4.115E+11	4.148E+11	4.713E+11	5.030E+11	5.321E+11	5.713E+11	5.614E+11	5.454E+11	5.415E+11	5.414E+11
8	3.661E+11	3.663E+11	3.692E+11	4.274E+11	4.616E+11	4.919E+11	5.304E+11	5.195E+11	5.005E+11	4.961E+11	4.961E+11
9	3.486E+11	3.488E+11	3.517E+11	4.095E+11	4.448E+11	4.753E+11	5.132E+11	5.023E+11	4.824E+11	4.779E+11	4.779E+11
10	3.363E+11	3.365E+11	3.394E+11	3.972E+11	4.324E+11	4.629E+11	5.002E+11	4.894E+11	4.691E+11	4.646E+11	4.646E+11
11	3.267E+11	3.269E+11	3.298E+11	3.873E+11	4.226E+11	4.529E+11	4.898E+11	4.792E+11	4.586E+11	4.541E+11	4.541E+11
12	3.156E+11	3.158E+11	3.187E+11	3.756E+11	4.109E+11	4.410E+11	4.772E+11	4.669E+11	4.461E+11	4.417E+11	4.416E+11

Information Processing Center

Information Processing Center

Information Processing Center

Information Processing Center

13	3.019E+11	3.021E+11	3.048E+11	3.607E+11	3.959E+11	4.256E+11	4.609E+11	4.511E+11	4.303E+11	4.259E+11	4.258E+11
14	2.880E+11	2.881E+11	2.908E+11	3.454E+11	3.803E+11	4.093E+11	4.435E+11	4.343E+11	4.137E+11	4.094E+11	4.094E+11
15	2.675E+11	2.677E+11	2.703E+11	3.226E+11	3.565E+11	3.844E+11	4.170E+11	4.088E+11	3.888E+11	3.847E+11	3.847E+11
16	1.155E+11	1.156E+11	1.170E+11	1.467E+11	1.678E+11	1.839E+11	2.017E+11	2.030E+11	1.929E+11	1.913E+11	1.915E+11
17	2.724E+10	2.726E+10	2.766E+10	3.698E+10	4.587E+10	4.936E+10	5.246E+10	5.143E+10	5.087E+10	5.173E+10	5.258E+10
18	9.635E+09	9.645E+09	9.787E+09	1.329E+10	1.765E+10	1.841E+10	1.937E+10	1.854E+10	1.880E+10	1.925E+10	1.985E+10
19	6.861E+08	6.868E+08	6.969E+08	9.671E+08	1.288E+09	1.345E+09	1.360E+09	1.299E+09	1.345E+09	1.411E+09	1.452E+09

GROUP 2 FLUX

PLANE NUMBER 1		Information Processing Center										
	1	2	3	4	5	6	7	8	9	10	11	
1	1.597E+11	1.597E+11	1.597E+11	1.602E+11	1.605E+11	1.609E+11	1.617E+11	1.624E+11	1.631E+11	1.634E+11	1.634E+11	
2	1.566E+11	1.566E+11	1.567E+11	1.576E+11	1.581E+11	1.585E+11	1.598E+11	1.610E+11	1.622E+11	1.628E+11	1.629E+11	
3	1.534E+11	1.534E+11	1.535E+11	1.548E+11	1.554E+11	1.560E+11	1.576E+11	1.593E+11	1.608E+11	1.618E+11	1.619E+11	
4	1.503E+11	1.503E+11	1.503E+11	1.520E+11	1.528E+11	1.535E+11	1.552E+11	1.572E+11	1.591E+11	1.603E+11	1.604E+11	
5	1.467E+11	1.467E+11	1.468E+11	1.489E+11	1.498E+11	1.506E+11	1.523E+11	1.547E+11	1.569E+11	1.584E+11	1.585E+11	
6	1.338E+11	1.338E+11	1.340E+11	1.377E+11	1.388E+11	1.398E+11	1.411E+11	1.441E+11	1.473E+11	1.498E+11	1.500E+11	
7	1.114E+11	1.113E+11	1.110E+11	1.135E+11	1.146E+11	1.155E+11	1.176E+11	1.208E+11	1.243E+11	1.272E+11	1.274E+11	
8	9.847E+10	9.829E+10	9.584E+10	9.779E+10	9.964E+10	9.957E+10	1.015E+11	1.056E+11	1.076E+11	1.104E+11	1.116E+11	
9	9.336E+10	9.306E+10	8.898E+10	9.073E+10	9.360E+10	9.239E+10	9.422E+10	9.956E+10	1.000E+11	1.028E+11	1.051E+11	
10	9.056E+10	9.014E+10	8.303E+10	8.465E+10	8.921E+10	8.621E+10	8.789E+10	9.519E+10	9.338E+10	9.605E+10	1.003E+11	
11	8.851E+10	8.822E+10	7.781E+10	7.934E+10	8.583E+10	8.080E+10	8.236E+10	9.182E+10	8.754E+10	9.014E+10	9.657E+10	
12	8.635E+10	8.631E+10	6.870E+10	7.006E+10	8.204E+10	7.136E+10	7.270E+10	8.799E+10	7.733E+10	7.974E+10	9.242E+10	
13	8.214E+10	8.143E+10	6.975E+10	7.102E+10	7.774E+10	7.234E+10	7.380E+10	8.344E+10	7.857E+10	8.098E+10	8.771E+10	
14	7.678E+10	7.622E+10	6.825E+10	6.942E+10	7.365E+10	7.071E+10	7.221E+10	7.899E+10	7.692E+10	7.924E+10	8.323E+10	
15	6.944E+10	6.910E+10	6.440E+10	6.542E+10	6.763E+10	6.665E+10	6.815E+10	7.244E+10	7.265E+10	7.477E+10	7.658E+10	
16	2.068E+10	2.066E+10	2.044E+10	2.075E+10	2.097E+10	2.117E+10	2.176E+10	2.255E+10	2.332E+10	2.399E+10	2.406E+10	
17	2.513E+09	2.512E+09	2.497E+09	2.533E+09	2.559E+09	2.586E+09	2.664E+09	2.761E+09	2.862E+09	2.945E+09	2.950E+09	
18	2.211E+09	2.210E+09	2.200E+09	2.232E+09	2.255E+09	2.279E+09	2.350E+09	2.437E+09	2.527E+09	2.601E+09	2.606E+09	
19	8.039E+08	8.039E+08	8.031E+08	8.173E+08	8.268E+08	8.372E+08	8.667E+08	8.998E+08	9.330E+08	9.591E+08	9.607E+08	

PLANE NUMBER 2		Information Processing Center										
	1	2	3	4	5	6	7	8	9	10	11	
1	6.394E+12	6.394E+12	6.394E+12	6.388E+12	6.380E+12	6.370E+12	6.365E+12	6.382E+12	6.399E+12	6.411E+12	6.412E+12	
2	6.195E+12	6.195E+12	6.195E+12	6.224E+12	6.242E+12	6.239E+12	6.254E+12	6.298E+12	6.341E+12	6.373E+12	6.375E+12	
3	6.073E+12	6.073E+12	6.070E+12	6.122E+12	6.117E+12	6.117E+12	6.140E+12	6.213E+12	6.273E+12	6.327E+12	6.331E+12	
4	5.930E+12	5.928E+12	5.906E+12	6.004E+12	6.032E+12	6.030E+12	6.042E+12	6.155E+12	6.205E+12	6.279E+12	6.298E+12	
5	5.777E+12	5.775E+12	5.751E+12	5.904E+12	5.937E+12	5.955E+12	5.946E+12	6.078E+12	6.140E+12	6.234E+12	6.242E+12	
6	5.213E+12	5.217E+12	5.272E+12	5.688E+12	5.749E+12	5.774E+12	5.572E+12	5.652E+12	5.845E+12	6.013E+12	6.023E+12	
7	4.185E+12	4.193E+12	4.300E+12	4.508E+12	4.561E+12	4.593E+12	4.592E+12	4.636E+12	4.885E+12	5.075E+12	5.089E+12	
8	3.526E+12	3.537E+12	3.694E+12	3.866E+12	3.936E+12	3.944E+12	3.958E+12	4.042E+12	4.226E+12	4.408E+12	4.442E+12	
9	3.238E+12	3.250E+12	3.453E+12	3.615E+12	3.700E+12	3.690E+12	3.705E+12	3.812E+12	3.961E+12	4.139E+12	4.192E+12	
10	3.046E+12	3.043E+12	3.250E+12	3.403E+12	3.506E+12	3.473E+12	3.489E+12	3.646E+12	3.733E+12	3.905E+12	3.979E+12	
11	2.956E+12	2.954E+12	3.078E+12	3.224E+12	3.364E+12	3.291E+12	3.306E+12	3.524E+12	3.538E+12	3.704E+12	3.821E+12	
12	2.855E+12	2.858E+12	2.665E+12	2.790E+12	3.212E+12	2.848E+12	2.862E+12	3.391E+12	3.065E+12	3.214E+12	3.654E+12	
13	2.796E+12	2.785E+12	2.601E+12	2.718E+12	3.049E+12	2.775E+12	2.792E+12	3.242E+12	2.992E+12	3.140E+12	3.471E+12	
14	2.688E+12	2.678E+12	2.543E+12	2.653E+12	2.891E+12	2.709E+12	2.729E+12	3.084E+12	2.926E+12	3.070E+12	3.296E+12	
15	2.497E+12	2.491E+12	2.400E+12	2.499E+12	2.649E+12	2.552E+12	2.576E+12	2.835E+12	2.763E+12	2.895E+12	3.026E+12	
16	9.046E+11	9.042E+11	8.988E+11	9.201E+11	9.337E+11	9.399E+11	9.634E+11	1.005E+12	1.036E+12	1.073E+12	1.078E+12	
17	9.271E+10	9.268E+10	9.226E+10	9.397E+10	9.504E+10	9.630E+10	9.894E+10	1.028E+11	1.066E+11	1.100E+11	1.103E+11	
18	5.219E+10	5.217E+10	5.194E+10	5.282E+10	5.340E+10	5.398E+10	5.569E+10	5.785E+10	6.002E+10	6.192E+10	6.205E+10	
19	5.141E+09	5.140E+09	5.133E+09	5.228E+09	5.291E+09	5.359E+09	5.549E+09	5.764E+09	5.979E+09	6.154E+09	6.165E+09	

PLANE NUMBER 3		Information Processing Center										
	1	2	3	4	5	6	7	8	9	10	11	
1	1.663E+13	1.663E+13	1.663E+13	1.667E+13	1.669E+13	1.682E+13	1.717E+13	1.740E+13	1.762E+13	1.774E+13	1.775E+13	
2	1.583E+13	1.583E+13	1.582E+13	1.602E+13	1.602E+13	1.593E+13	1.614E+13	1.645E+13	1.670E+13	1.696E+13	1.699E+13	
3	1.377E+13	1.376E+13	1.372E+13	1.401E+13	1.431E+13	1.450E+13	1.472E+13	1.524E+13	1.539E+13	1.585E+13	1.597E+13	
4	1.350E+13	1.349E+13	1.259E+13	1.299E+13	1.383E+13	1.274E+13	1.268E+13	1.430E+13	1.337E+13	1.405E+13	1.531E+13	
5	1.336E+13	1.337E+13	1.384E+13	1.443E+13	1.458E+13	1.447E+13	1.436E+13	1.424E+13	1.528E+13	1.614E+13	1.632E+13	

6	1.028E+13	1.046E+13	1.453E+13	1.506E+13	1.513E+13	1.518E+13	1.549E+13	1.129E+13	1.690E+13	1.841E+13	1.849E+13
7	7.229E+12	7.436E+12	1.213E+13	1.323E+13	1.344E+13	1.348E+13	1.307E+13	8.045E+12	1.422E+13	1.555E+13	1.567E+13
8	7.129E+12	7.268E+12	1.013E+13	1.104E+13	1.152E+13	1.130E+13	1.099E+13	8.079E+12	1.195E+13	1.301E+13	1.339E+13
9	7.505E+12	7.853E+12	9.637E+12	1.051E+13	1.113E+13	1.077E+13	1.049E+13	8.600E+12	1.140E+13	1.240E+13	1.292E+13
10	7.773E+12	8.029E+12	9.513E+12	1.036E+13	1.100E+13	1.063E+13	1.035E+13	9.398E+12	1.125E+13	1.223E+13	1.277E+13
11	8.098E+12	8.289E+12	9.414E+12	1.024E+13	1.062E+13	1.051E+13	1.025E+13	9.907E+12	1.114E+13	1.209E+13	1.234E+13
12	7.958E+12	7.998E+12	8.561E+12	9.242E+12	9.977E+12	9.474E+12	9.309E+12	9.876E+12	1.011E+13	1.091E+13	1.161E+13
13	8.001E+12	8.010E+12	8.681E+12	9.219E+12	9.523E+12	9.441E+12	9.416E+12	9.684E+12	1.020E+13	1.088E+13	1.108E+13
14	8.003E+12	8.028E+12	8.408E+12	8.918E+12	9.398E+12	9.131E+12	9.127E+12	9.614E+12	9.879E+12	1.052E+13	1.093E+13
15	7.875E+12	7.894E+12	8.162E+12	8.633E+12	8.997E+12	8.838E+12	8.856E+12	9.301E+12	9.582E+12	1.018E+13	1.047E+13
16	3.781E+12	3.781E+12	3.788E+12	3.901E+12	3.972E+12	3.991E+12	4.085E+12	4.250E+12	4.407E+12	4.583E+12	4.603E+12
17	8.549E+11	8.549E+11	8.542E+11	8.732E+11	8.836E+11	8.933E+11	9.203E+11	9.566E+11	9.927E+11	1.026E+12	1.029E+12
18	3.109E+11	3.109E+11	3.101E+11	3.162E+11	3.199E+11	3.235E+11	3.337E+11	3.469E+11	3.601E+11	3.719E+11	3.728E+11
19	1.055E+10	1.055E+10	1.053E+10	1.073E+10	1.087E+10	1.101E+10	1.141E+10	1.185E+10	1.230E+10	1.266E+10	1.269E+10

PLANE NUMBER 4

1	2.745E+13	2.745E+13	2.746E+13	2.757E+13	2.763E+13	2.798E+13	2.889E+13	2.943E+13	2.993E+13	3.019E+13	3.021E+13
2	2.619E+13	2.619E+13	2.619E+13	2.659E+13	2.655E+13	2.654E+13	2.722E+13	2.789E+13	2.846E+13	2.896E+13	2.900E+13
3	2.261E+13	2.261E+13	2.254E+13	2.300E+13	2.360E+13	2.408E+13	2.485E+13	2.585E+13	2.627E+13	2.710E+13	2.732E+13
4	2.218E+13	2.216E+13	2.075E+13	2.126E+13	2.263E+13	2.097E+13	2.137E+13	2.413E+13	2.281E+13	2.403E+13	2.614E+13
5	2.198E+13	2.200E+13	2.294E+13	2.345E+13	2.370E+13	2.361E+13	2.418E+13	2.400E+13	2.609E+13	2.763E+13	2.794E+13
6	1.705E+13	1.735E+13	2.417E+13	2.392E+13	2.402E+13	2.414E+13	2.602E+13	1.907E+13	2.888E+13	3.149E+13	3.164E+13
7	1.191E+13	1.225E+13	2.010E+13	2.159E+13	2.195E+13	2.205E+13	2.183E+13	1.344E+13	2.399E+13	2.623E+13	2.644E+13
8	1.160E+13	1.183E+13	1.645E+13	1.776E+13	1.860E+13	1.822E+13	1.797E+13	1.334E+13	1.969E+13	2.143E+13	2.211E+13
9	1.217E+13	1.272E+13	1.553E+13	1.681E+13	1.789E+13	1.726E+13	1.700E+13	1.416E+13	1.861E+13	2.023E+13	2.118E+13
10	1.260E+13	1.300E+13	1.531E+13	1.656E+13	1.774E+13	1.702E+13	1.677E+13	1.550E+13	1.836E+13	1.993E+13	2.097E+13
11	1.314E+13	1.341E+13	1.515E+13	1.637E+13	1.716E+13	1.683E+13	1.660E+13	1.633E+13	1.817E+13	1.970E+13	2.028E+13
12	1.287E+13	1.293E+13	1.384E+13	1.484E+13	1.610E+13	1.524E+13	1.514E+13	1.621E+13	1.655E+13	1.783E+13	1.903E+13
13	1.292E+13	1.293E+13	1.414E+13	1.492E+13	1.531E+13	1.543E+13	1.543E+13	1.579E+13	1.682E+13	1.789E+13	1.805E+13
14	1.292E+13	1.297E+13	1.365E+13	1.439E+13	1.510E+13	1.476E+13	1.490E+13	1.567E+13	1.622E+13	1.722E+13	1.781E+13
15	1.277E+13	1.280E+13	1.328E+13	1.396E+13	1.451E+13	1.432E+13	1.449E+13	1.522E+13	1.576E+13	1.670E+13	1.711E+13
16	6.204E+12	6.204E+12	6.215E+12	6.379E+12	6.473E+12	6.536E+12	6.730E+12	7.014E+12	7.285E+12	7.560E+12	7.590E+12
17	1.369E+12	1.369E+12	1.368E+12	1.396E+12	1.413E+12	1.430E+12	1.479E+12	1.539E+12	1.598E+12	1.650E+12	1.654E+12
18	5.069E+11	5.068E+11	5.054E+11	5.145E+11	5.207E+11	5.270E+11	5.459E+11	5.682E+11	5.903E+11	6.089E+11	6.102E+11
19	1.584E+10	1.584E+10	1.581E+10	1.614E+10	1.637E+10	1.660E+10	1.723E+10	1.791E+10	1.858E+10	1.912E+10	1.916E+10

PLANE NUMBER 5

1	4.064E+13	4.064E+13	4.065E+13	4.081E+13	4.089E+13	4.139E+13	4.271E+13	4.352E+13	4.427E+13	4.466E+13	4.469E+13
2	3.881E+13	3.881E+13	3.880E+13	3.927E+13	3.930E+13	3.925E+13	4.029E+13	4.133E+13	4.220E+13	4.293E+13	4.299E+13
3	3.375E+13	3.375E+13	3.364E+13	3.418E+13	3.497E+13	3.558E+13	3.684E+13	3.841E+13	3.905E+13	4.024E+13	4.056E+13
4	3.306E+13	3.304E+13	3.086E+13	3.139E+13	3.330E+13	3.080E+13	3.169E+13	3.602E+13	3.394E+13	3.566E+13	3.881E+13
5	3.268E+13	3.270E+13	3.375E+13	3.403E+13	3.437E+13	3.423E+13	3.565E+13	3.583E+13	3.861E+13	4.072E+13	4.118E+13
6	2.518E+13	2.559E+13	3.483E+13	3.407E+13	3.421E+13	3.441E+13	3.771E+13	2.842E+13	4.203E+13	4.551E+13	4.571E+13
7	1.776E+13	1.822E+13	2.866E+13	3.048E+13	3.099E+13	3.117E+13	3.129E+13	2.028E+13	3.447E+13	3.735E+13	3.763E+13
8	1.699E+13	1.728E+13	2.330E+13	2.485E+13	2.608E+13	2.557E+13	2.557E+13	1.976E+13	2.805E+13	3.024E+13	3.121E+13
9	1.761E+13	1.832E+13	2.194E+13	2.349E+13	2.503E+13	2.416E+13	2.412E+13	2.071E+13	2.645E+13	2.847E+13	2.982E+13
10	1.813E+13	1.864E+13	2.163E+13	2.313E+13	2.480E+13	2.381E+13	2.379E+13	2.243E+13	2.608E+13	2.803E+13	2.951E+13
11	1.878E+13	1.911E+13	2.140E+13	2.286E+13	2.396E+13	2.353E+13	2.353E+13	2.342E+13	2.579E+13	2.770E+13	2.850E+13
12	1.832E+13	1.840E+13	1.950E+13	2.070E+13	2.242E+13	2.129E+13	2.142E+13	2.308E+13	2.344E+13	2.504E+13	2.665E+13
13	1.836E+13	1.838E+13	1.985E+13	2.077E+13	2.123E+13	2.134E+13	2.174E+13	2.240E+13	2.373E+13	2.506E+13	2.520E+13
14	1.835E+13	1.839E+13	1.911E+13	1.998E+13	2.095E+13	2.052E+13	2.093E+13	2.221E+13	2.281E+13	2.405E+13	2.486E+13
15	1.806E+13	1.809E+13	1.857E+13	1.937E+13	2.012E+13	1.989E+13	2.032E+13	2.150E+13	2.214E+13	2.330E+13	2.386E+13
16	8.474E+12	8.474E+12	8.471E+12	8.667E+12	8.795E+12	8.888E+12	9.200E+12	9.607E+12	9.967E+12	1.031E+13	1.035E+13
17	1.828E+12	1.828E+12	1.825E+12	1.859E+12	1.883E+12	1.906E+12	1.979E+12	2.062E+12	2.140E+12	2.205E+12	2.209E+12
18	6.774E+11	6.773E+11	6.751E+11	6.865E+11	6.950E+11	7.039E+11	7.316E+11	7.621E+11	7.914E+11	8.150E+11	8.167E+11
19	2.018E+10	2.017E+10	2.014E+10	2.060E+10	2.094E+10	2.127E+10	2.211E+10	2.297E+10	2.382E+10	2.450E+10	2.455E+10

PLANE NUMBER 6

1	5.854E+13	5.854E+13	5.856E+13	5.882E+13	5.898E+13	5.974E+13	6.188E+13	6.321E+13	6.445E+13	6.505E+13	6.508E+13
2	5.818E+13	5.819E+13	5.826E+13	5.863E+13	5.826E+13	5.865E+13	6.110E+13	6.278E+13	6.448E+13	6.540E+13	6.545E+13

Information Processing Center

Information Processing Center

3	5.378E+13	5.380E+13	5.401E+13	5.428E+13	5.511E+13	5.651E+13	5.983E+13	6.159E+13	6.395E+13	6.523E+13	6.528E+13
4	5.274E+13	5.281E+13	5.374E+13	5.368E+13	5.387E+13	5.477E+13	5.858E+13	5.940E+13	6.309E+13	6.463E+13	6.458E+13
5	5.099E+13	5.101E+13	5.266E+13	5.083E+13	5.115E+13	5.193E+13	5.760E+13	5.784E+13	6.255E+13	6.443E+13	6.452E+13
6	4.581E+13	4.585E+13	4.847E+13	4.556E+13	4.572E+13	4.615E+13	5.312E+13	5.293E+13	5.908E+13	6.167E+13	6.182E+13
7	3.714E+13	3.716E+13	3.870E+13	3.965E+13	4.027E+13	4.064E+13	4.259E+13	4.390E+13	4.672E+13	4.872E+13	4.902E+13
8	3.308E+13	3.305E+13	3.104E+13	3.196E+13	3.345E+13	3.288E+13	3.419E+13	4.028E+13	3.736E+13	3.890E+13	4.009E+13
9	3.166E+13	3.149E+13	2.921E+13	3.014E+13	3.207E+13	3.105E+13	3.218E+13	3.911E+13	3.513E+13	3.657E+13	3.826E+13
10	3.068E+13	3.025E+13	2.877E+13	2.968E+13	3.175E+13	3.058E+13	3.169E+13	3.790E+13	3.458E+13	3.600E+13	3.784E+13
11	2.884E+13	2.847E+13	2.843E+13	2.932E+13	3.060E+13	3.022E+13	3.131E+13	3.551E+13	3.417E+13	3.556E+13	3.646E+13
12	2.633E+13	2.647E+13	2.571E+13	2.647E+13	2.850E+13	2.726E+13	2.827E+13	3.246E+13	3.083E+13	3.206E+13	3.394E+13
13	2.585E+13	2.585E+13	2.578E+13	2.642E+13	2.690E+13	2.717E+13	2.825E+13	3.036E+13	3.077E+13	3.192E+13	3.196E+13
14	2.553E+13	2.548E+13	2.466E+13	2.532E+13	2.652E+13	2.603E+13	2.702E+13	2.990E+13	2.939E+13	3.051E+13	3.150E+13
15	2.458E+13	2.453E+13	2.388E+13	2.449E+13	2.541E+13	2.517E+13	2.614E+13	2.856E+13	2.842E+13	2.949E+13	3.017E+13
16	1.038E+13	1.037E+13	1.031E+13	1.051E+13	1.066E+13	1.078E+13	1.122E+13	1.176E+13	1.214E+13	1.251E+13	1.255E+13
17	2.159E+12	2.159E+12	2.153E+12	2.192E+12	2.221E+12	2.251E+12	2.343E+12	2.442E+12	2.531E+12	2.602E+12	2.607E+12
18	7.980E+11	7.978E+11	7.951E+11	8.084E+11	8.190E+11	8.301E+11	8.647E+11	9.009E+11	9.345E+11	9.606E+11	9.625E+11
19	2.281E+10	2.281E+10	2.278E+10	2.342E+10	2.398E+10	2.437E+10	2.533E+10	2.627E+10	2.723E+10	2.800E+10	2.806E+10

PLANE NUMBER 7

1	6.668E+13	6.668E+13	6.670E+13	6.699E+13	6.716E+13	6.799E+13	7.037E+13	7.186E+13	7.325E+13	7.393E+13	7.396E+13
2	6.626E+13	6.626E+13	6.634E+13	6.671E+13	6.630E+13	6.669E+13	6.941E+13	7.131E+13	7.322E+13	7.425E+13	7.431E+13
3	6.136E+13	6.137E+13	6.157E+13	6.178E+13	6.266E+13	6.411E+13	6.780E+13	6.986E+13	7.247E+13	7.390E+13	7.398E+13
4	6.009E+13	6.016E+13	6.107E+13	6.087E+13	6.103E+13	6.181E+13	6.606E+13	6.730E+13	7.114E+13	7.287E+13	7.297E+13
5	5.808E+13	5.811E+13	5.992E+13	5.760E+13	5.790E+13	5.873E+13	6.528E+13	6.564E+13	7.088E+13	7.296E+13	7.308E+13
6	5.162E+13	5.167E+13	5.501E+13	5.140E+13	5.162E+13	5.206E+13	6.026E+13	5.951E+13	6.702E+13	6.978E+13	6.994E+13
7	4.224E+13	4.227E+13	4.427E+13	4.504E+13	4.570E+13	4.615E+13	4.866E+13	4.959E+13	5.332E+13	5.537E+13	5.565E+13
8	3.788E+13	3.784E+13	3.586E+13	3.661E+13	3.817E+13	3.765E+13	3.941E+13	4.565E+13	4.300E+13	4.450E+13	4.575E+13
9	3.633E+13	3.616E+13	3.386E+13	3.462E+13	3.617E+13	3.565E+13	3.721E+13	4.439E+13	4.056E+13	4.194E+13	4.371E+13
10	3.523E+13	3.478E+13	3.336E+13	3.410E+13	3.623E+13	3.513E+13	3.665E+13	4.309E+13	3.995E+13	4.129E+13	4.321E+13
11	3.312E+13	3.278E+13	3.297E+13	3.369E+13	3.488E+13	3.471E+13	3.622E+13	4.043E+13	3.947E+13	4.079E+13	4.156E+13
12	3.025E+13	3.042E+13	2.973E+13	3.036E+13	3.238E+13	3.126E+13	3.262E+13	3.695E+13	3.553E+13	3.671E+13	3.854E+13
13	2.970E+13	2.970E+13	2.956E+13	3.011E+13	3.051E+13	3.096E+13	3.235E+13	3.456E+13	3.519E+13	3.632E+13	3.624E+13
14	2.932E+13	2.926E+13	2.824E+13	2.880E+13	3.007E+13	2.960E+13	3.088E+13	3.403E+13	3.356E+13	3.466E+13	3.570E+13
15	2.813E+13	2.807E+13	2.726E+13	2.780E+13	2.876E+13	2.857E+13	2.980E+13	3.244E+13	3.237E+13	3.343E+13	3.413E+13
16	1.136E+13	1.136E+13	1.129E+13	1.149E+13	1.166E+13	1.179E+13	1.229E+13	1.288E+13	1.329E+13	1.367E+13	1.371E+13
17	2.317E+12	2.317E+12	2.311E+12	2.354E+12	2.387E+12	2.421E+12	2.522E+12	2.628E+12	2.721E+12	2.794E+12	2.800E+12
18	8.544E+11	8.543E+11	8.517E+11	8.669E+11	8.789E+11	8.913E+11	9.293E+11	9.677E+11	1.003E+12	1.030E+12	1.032E+12
19	2.394E+10	2.394E+10	2.391E+10	2.472E+10	2.540E+10	2.591E+10	2.693E+10	2.786E+10	2.887E+10	2.970E+10	2.978E+10

PLANE NUMBER 8

1	7.093E+13	7.093E+13	7.095E+13	7.125E+13	7.144E+13	7.232E+13	7.482E+13	7.639E+13	7.785E+13	7.857E+13	7.861E+13
2	7.055E+13	7.055E+13	7.063E+13	7.100E+13	7.055E+13	7.096E+13	7.381E+13	7.581E+13	7.782E+13	7.891E+13	7.897E+13
3	6.539E+13	6.540E+13	6.561E+13	6.579E+13	6.672E+13	6.824E+13	7.212E+13	7.429E+13	7.702E+13	7.852E+13	7.860E+13
4	6.409E+13	6.415E+13	6.510E+13	6.484E+13	6.499E+13	6.579E+13	7.028E+13	7.159E+13	7.561E+13	7.743E+13	7.753E+13
5	6.203E+13	6.206E+13	6.397E+13	6.142E+13	6.173E+13	6.259E+13	6.954E+13	6.986E+13	7.544E+13	7.762E+13	7.774E+13
6	5.543E+13	5.549E+13	5.910E+13	5.490E+13	5.513E+13	5.559E+13	6.454E+13	6.349E+13	7.170E+13	7.461E+13	7.477E+13
7	4.643E+13	4.646E+13	4.863E+13	4.913E+13	4.974E+13	5.030E+13	5.319E+13	5.346E+13	5.820E+13	6.033E+13	6.056E+13
8	4.304E+13	4.300E+13	4.076E+13	4.126E+13	4.241E+13	4.239E+13	4.452E+13	4.967E+13	4.850E+13	4.998E+13	5.079E+13
9	4.203E+13	4.183E+13	3.903E+13	3.953E+13	4.093E+13	4.065E+13	4.261E+13	4.851E+13	4.637E+13	4.770E+13	4.881E+13
10	4.099E+13	4.037E+13	3.871E+13	3.919E+13	4.049E+13	4.032E+13	4.224E+13	4.721E+13	4.597E+13	4.727E+13	4.827E+13
11	3.867E+13	3.857E+13	3.850E+13	3.897E+13	3.889E+13	4.010E+13	4.201E+13	4.439E+13	4.572E+13	4.699E+13	4.641E+13
12	3.532E+13	3.542E+13	3.764E+13	3.808E+13	3.596E+13	3.917E+13	4.107E+13	4.047E+13	4.467E+13	4.590E+13	4.282E+13
13	3.304E+13	3.306E+13	3.462E+13	3.504E+13	3.375E+13	3.601E+13	3.775E+13	3.780E+13	4.102E+13	4.214E+13	4.006E+13
14	3.256E+13	3.254E+13	3.212E+13	3.257E+13	3.326E+13	3.345E+13	3.502E+13	3.723E+13	3.800E+13	3.907E+13	3.945E+13
15	3.102E+13	3.099E+13	3.063E+13	3.107E+13	3.168E+13	3.191E+13	3.339E+13	3.541E+13	3.622E+13	3.724E+13	3.755E+13
16	1.192E+13	1.192E+13	1.188E+13	1.208E+13	1.224E+13	1.240E+13	1.294E+13	1.351E+13	1.397E+13	1.434E+13	1.438E+13
17	2.389E+12	2.389E+12	2.385E+12	2.434E+12	2.471E+12	2.508E+12	2.615E+12	2.721E+12	2.815E+12	2.889E+12	2.895E+12
18	8.784E+11	8.782E+11	8.764E+11	8.943E+11	9.083E+11	9.219E+11	9.612E+11	1.000E+12	1.035E+12	1.063E+12	1.065E+12
19	2.431E+10	2.431E+10	2.430E+10	2.533E+10	2.629E+10	2.688E+10	2.789E+10	2.876E+10	2.980E+10	3.068E+10	3.079E+10

PLANE NUMBER 9

1	7.093E+13	7.093E+13	7.095E+13	7.125E+13	7.144E+13	7.232E+13	7.482E+13	7.639E+13	7.785E+13	7.857E+13	7.861E+13
---	-----------	-----------	-----------	-----------	-----------	-----------	-----------	-----------	-----------	-----------	-----------

Information Processing Center

Information Processing Center

Information Processing Center

Information Processing Center

	1	2	3	4	5	6	7	8	9	10	11
1	7.105E+13	7.105E+13	7.107E+13	7.136E+13	7.154E+13	7.240E+13	7.484E+13	7.634E+13	7.775E+13	7.843E+13	7.877E+13
2	7.080E+13	7.081E+13	7.089E+13	7.124E+13	7.072E+13	7.112E+13	7.387E+13	7.577E+13	7.768E+13	7.872E+13	7.878E+13
3	6.575E+13	6.577E+13	6.596E+13	6.613E+13	6.703E+13	6.850E+13	7.223E+13	7.427E+13	7.687E+13	7.830E+13	7.838E+13
4	6.453E+13	6.459E+13	6.549E+13	6.522E+13	6.537E+13	6.614E+13	7.042E+13	7.162E+13	7.548E+13	7.721E+13	7.731E+13
5	6.258E+13	6.261E+13	6.451E+13	6.202E+13	6.231E+13	6.313E+13	6.979E+13	6.995E+13	7.541E+13	7.750E+13	7.762E+13
6	5.638E+13	5.644E+13	6.009E+13	5.578E+13	5.599E+13	5.643E+13	6.520E+13	6.390E+13	7.209E+13	7.489E+13	7.504E+13
7	4.796E+13	4.800E+13	5.037E+13	5.067E+13	5.123E+13	5.179E+13	5.466E+13	5.438E+13	5.957E+13	6.164E+13	6.185E+13
8	4.478E+13	4.474E+13	4.272E+13	4.305E+13	4.407E+13	4.414E+13	4.630E+13	5.079E+13	5.026E+13	5.166E+13	5.237E+13
9	4.382E+13	4.363E+13	4.102E+13	4.136E+13	4.261E+13	4.244E+13	4.444E+13	4.969E+13	4.820E+13	4.944E+13	5.043E+13
10	4.272E+13	4.218E+13	4.069E+13	4.102E+13	4.214E+13	4.211E+13	4.407E+13	4.840E+13	4.780E+13	4.901E+13	4.987E+13
11	4.024E+13	4.028E+13	4.047E+13	4.079E+13	4.043E+13	4.188E+13	4.383E+13	4.555E+13	4.754E+13	4.873E+13	4.790E+13
12	3.670E+13	3.684E+13	3.945E+13	3.977E+13	3.729E+13	3.729E+13	4.082E+13	4.274E+13	4.151E+13	4.634E+13	4.750E+13
13	3.432E+13	3.433E+13	3.609E+13	3.643E+13	3.496E+13	3.737E+13	3.912E+13	3.880E+13	4.236E+13	4.345E+13	4.122E+13
14	3.381E+13	3.379E+13	3.343E+13	3.381E+13	3.444E+13	3.467E+13	3.624E+13	3.821E+13	3.921E+13	4.023E+13	4.058E+13
15	3.211E+13	3.209E+13	3.180E+13	3.218E+13	3.275E+13	3.300E+13	3.448E+13	3.629E+13	3.729E+13	3.827E+13	3.855E+13
16	1.186E+13	1.186E+13	1.183E+13	1.205E+13	1.222E+13	1.239E+13	1.291E+13	1.346E+13	1.389E+13	1.425E+13	1.428E+13
17	2.339E+12	2.339E+12	2.337E+12	2.402E+12	2.450E+12	2.493E+12	2.598E+12	2.696E+12	2.783E+12	2.855E+12	2.861E+12
18	8.562E+11	8.561E+11	8.552E+11	8.797E+11	8.991E+11	9.145E+11	9.527E+11	9.885E+11	1.021E+12	1.048E+12	1.050E+12
19	2.364E+10	2.364E+10	2.366E+10	2.514E+10	2.677E+10	2.749E+10	2.842E+10	2.904E+10	3.014E+10	3.110E+10	3.129E+10

PLANE NUMBER 10

	1	2	3	4	5	6	7	8	9	10	11
1	6.008E+13	6.008E+13	6.009E+13	6.015E+13	6.019E+13	6.046E+13	6.143E+13	6.219E+13	6.292E+13	6.329E+13	6.331E+13
2	5.959E+13	5.960E+13	5.965E+13	5.983E+13	5.927E+13	5.917E+13	6.041E+13	6.151E+13	6.264E+13	6.327E+13	6.330E+13
3	5.587E+13	5.588E+13	5.602E+13	5.604E+13	5.644E+13	5.706E+13	5.904E+13	6.032E+13	6.194E+13	6.283E+13	6.288E+13
4	5.482E+13	5.486E+13	5.554E+13	5.531E+13	5.519E+13	5.546E+13	5.778E+13	5.859E+13	6.098E+13	6.206E+13	6.212E+13
5	5.319E+13	5.321E+13	5.426E+13	5.291E+13	5.304E+13	5.347E+13	5.726E+13	5.755E+13	6.092E+13	6.222E+13	6.229E+13
6	4.803E+13	4.805E+13	4.985E+13	4.885E+13	4.903E+13	4.930E+13	5.339E+13	5.336E+13	5.801E+13	5.975E+13	5.984E+13
7	4.081E+13	4.082E+13	4.172E+13	4.245E+13	4.279E+13	4.324E+13	4.481E+13	4.564E+13	4.844E+13	4.977E+13	4.983E+13
8	3.765E+13	3.762E+13	3.592E+13	3.622E+13	3.653E+13	3.701E+13	3.861E+13	4.217E+13	4.168E+13	4.253E+13	4.258E+13
9	3.670E+13	3.657E+13	3.470E+13	3.492E+13	3.526E+13	3.571E+13	3.731E+13	4.111E+13	4.027E+13	4.100E+13	4.109E+13
10	3.566E+13	3.536E+13	3.447E+13	3.468E+13	3.481E+13	3.549E+13	3.707E+13	3.992E+13	4.001E+13	4.074E+13	4.062E+13
11	3.363E+13	3.382E+13	3.432E+13	3.453E+13	3.345E+13	3.534E+13	3.691E+13	3.764E+13	3.984E+13	4.058E+13	3.912E+13
12	3.103E+13	3.115E+13	3.133E+13	3.339E+13	3.111E+13	3.416E+13	3.565E+13	3.475E+13	3.847E+13	3.926E+13	3.631E+13
13	2.941E+13	2.941E+13	2.994E+13	3.028E+13	2.947E+13	3.097E+13	3.225E+13	3.296E+13	3.476E+13	3.562E+13	3.431E+13
14	2.896E+13	2.889E+13	2.771E+13	2.812E+13	2.903E+13	2.876E+13	2.988E+13	3.246E+13	3.217E+13	3.305E+13	3.378E+13
15	2.741E+13	2.733E+13	2.633E+13	2.675E+13	2.754E+13	2.736E+13	2.841E+13	3.075E+13	3.058E+13	3.144E+13	3.203E+13
16	1.002E+13	1.001E+13	9.938E+12	1.020E+13	1.040E+13	1.055E+13	1.099E+13	1.149E+13	1.174E+13	1.203E+13	1.208E+13
17	2.007E+12	2.007E+12	2.004E+12	2.103E+12	2.187E+12	2.237E+12	2.327E+12	2.404E+12	2.468E+12	2.533E+12	2.541E+12
18	7.315E+11	7.314E+11	7.306E+11	7.695E+11	8.119E+11	8.268E+11	8.588E+11	8.840E+11	9.098E+11	9.349E+11	9.405E+11
19	2.105E+10	2.106E+10	2.110E+10	2.323E+10	2.639E+10	2.713E+10	2.781E+10	2.781E+10	2.913E+10	3.022E+10	3.067E+10

PLANE NUMBER 11

	1	2	3	4	5	6	7	8	9	10	11
1	5.550E+13	5.550E+13	5.549E+13	5.536E+13	5.526E+13	5.498E+13	5.478E+13	5.507E+13	5.538E+13	5.557E+13	5.558E+13
2	5.428E+13	5.428E+13	5.431E+13	5.439E+13	5.404E+13	5.336E+13	5.356E+13	5.427E+13	5.499E+13	5.541E+13	5.543E+13
3	5.146E+13	5.146E+13	5.155E+13	5.144E+13	5.137E+13	5.128E+13	5.227E+13	5.328E+13	5.436E+13	5.498E+13	5.501E+13
4	5.028E+13	5.030E+13	5.071E+13	5.048E+13	5.005E+13	4.998E+13	5.129E+13	5.232E+13	5.366E+13	5.437E+13	5.441E+13
5	4.900E+13	4.900E+13	4.890E+13	4.833E+13	4.835E+13	4.856E+13	5.071E+13	5.206E+13	5.347E+13	5.432E+13	5.437E+13
6	4.452E+13	4.451E+13	4.430E+13	4.588E+13	4.607E+13	4.626E+13	4.707E+13	4.904E+13	5.064E+13	5.182E+13	5.188E+13
7	3.766E+13	3.765E+13	3.692E+13	3.779E+13	3.795E+13	3.839E+13	3.941E+13	4.188E+13	4.247E+13	4.343E+13	4.337E+13
8	3.352E+13	3.350E+13	3.221E+13	3.243E+13	3.177E+13	3.305E+13	3.447E+13	3.733E+13	3.712E+13	3.768E+13	3.671E+13
9	3.175E+13	3.172E+13	3.126E+13	3.137E+13	3.021E+13	3.199E+13	3.348E+13	3.537E+13	3.605E+13	3.651E+13	3.498E+13
10	3.053E+13	3.055E+13	3.104E+13	3.114E+13	2.943E+13	3.176E+13	3.324E+13	3.401E+13	3.579E+13	3.626E+13	3.407E+13
11	2.966E+13	2.967E+13	3.049E+13	3.063E+13	2.879E+13	3.124E+13	3.267E+13	3.305E+13	3.517E+13	3.569E+13	3.332E+13
12	2.879E+13	2.879E+13	2.898E+13	2.922E+13	2.811E+13	2.980E+13	3.107E+13	3.209E+13	3.344E+13	3.410E+13	3.251E+13
13	2.790E+13	2.788E+13	2.631E+13	2.669E+13	2.739E+13	2.723E+13	2.824E+13	3.112E+13	3.037E+13	3.118E+13	3.167E+13
14	2.720E+13	2.705E+13	2.463E+13	2.508E+13	2.677E+13	2.558E+13	2.647E+13	3.034E+13	2.843E+13	2.928E+13	3.094E+13
15	2.535E+13	2.522E+13	2.345E+13	2.391E+13	2.513E+13	2.440E+13	2.523E+13	2.833E+13	2.709E+13	2.792E+13	2.903E+13
16	9.113E+12	9.106E+12	9.015E+12	9.308E+12	9.516E+12	9.661E+12	1.008E+13	1.054E+13	1.071E+13	1.097E+13	1.102E+13
17	1.847E+12	1.847E+12	1.845E+12	1.962E+12	2.073E+12	2.124E+12	2.207E+12	2.271E+12	2.327E+12	2.388E+12	2.400E+12
18	6.716E+11	6.716E+11	6.710E+11	7.184E+11	7.847E+11	7.942E+11	8.227E+11	8.402E+11	8.653E+11	8.902E+11	9.001E+11
19	1.981E+10	1.982E+10	1.987E+10	2.230E+10	2.634E+10	2.704E+10	2.760E+10	2.724E+10	2.872E+10	2.989E+10	3.049E+10

Information Processing Center

Information Processing Center

Information Processing Center

Information Processing Center

PLANE NUMBER 12

	1	2	3	4	5	6	7	8	9	10	11
1	5.049E+13	5.049E+13	5.048E+13	5.020E+13	4.990E+13	4.950E+13	4.919E+13	4.938E+13	4.960E+13	4.975E+13	4.976E+13
2	4.831E+13	4.831E+13	4.832E+13	4.844E+13	4.840E+13	4.794E+13	4.812E+13	4.869E+13	4.927E+13	4.959E+13	4.961E+13
3	4.704E+13	4.704E+13	4.705E+13	4.696E+13	4.643E+13	4.625E+13	4.695E+13	4.783E+13	4.866E+13	4.913E+13	4.916E+13
4	4.506E+13	4.506E+13	4.501E+13	4.496E+13	4.486E+13	4.488E+13	4.576E+13	4.683E+13	4.767E+13	4.819E+13	4.822E+13
5	4.481E+13	4.476E+13	4.395E+13	4.405E+13	4.415E+13	4.433E+13	4.549E+13	4.760E+13	4.778E+13	4.838E+13	4.842E+13
6	4.100E+13	4.091E+13	3.971E+13	4.208E+13	4.231E+13	4.248E+13	4.189E+13	4.496E+13	4.492E+13	4.580E+13	4.585E+13
7	3.455E+13	3.446E+13	3.306E+13	3.357E+13	3.366E+13	3.401E+13	3.505E+13	3.822E+13	3.780E+13	3.860E+13	3.855E+13
8	3.021E+13	3.016E+13	2.948E+13	2.965E+13	2.913E+13	3.013E+13	3.140E+13	3.351E+13	3.381E+13	3.434E+13	3.360E+13
9	2.864E+13	2.865E+13	2.876E+13	2.887E+13	2.800E+13	2.937E+13	3.069E+13	3.179E+13	3.302E+13	3.347E+13	3.234E+13
10	2.799E+13	2.801E+13	2.845E+13	2.857E+13	2.743E+13	2.906E+13	3.037E+13	3.107E+13	3.267E+13	3.313E+13	3.166E+13
11	2.741E+13	2.742E+13	2.760E+13	2.776E+13	2.688E+13	2.824E+13	2.947E+13	3.044E+13	3.169E+13	3.220E+13	3.102E+13
12	2.669E+13	2.668E+13	2.585E+13	2.611E+13	2.619E+13	2.656E+13	2.761E+13	2.965E+13	2.968E+13	3.032E+13	3.020E+13
13	2.576E+13	2.573E+13	2.337E+13	2.377E+13	2.531E+13	2.417E+13	2.499E+13	2.862E+13	2.682E+13	2.760E+13	2.915E+13
14	2.504E+13	2.487E+13	2.222E+13	2.268E+13	2.462E+13	2.307E+13	2.380E+13	2.782E+13	2.551E+13	2.632E+13	2.833E+13
15	2.320E+13	2.307E+13	2.121E+13	2.167E+13	2.295E+13	2.206E+13	2.275E+13	2.582E+13	2.437E+13	2.515E+13	2.639E+13
16	8.377E+12	8.370E+12	8.282E+12	8.600E+12	8.812E+12	8.973E+12	9.375E+12	9.799E+12	9.915E+12	1.014E+13	1.018E+13
17	1.720E+12	1.720E+12	1.718E+12	1.853E+12	1.997E+12	2.045E+12	2.123E+12	2.175E+12	2.225E+12	2.285E+12	2.300E+12
18	6.242E+11	6.242E+11	6.239E+11	6.801E+11	7.869E+11	7.825E+11	8.072E+11	8.142E+11	8.428E+11	8.686E+11	8.89E+11
19	1.882E+10	1.882E+10	1.888E+10	2.155E+10	2.645E+10	2.707E+10	2.752E+10	2.682E+10	2.850E+10	2.973E+10	3.051E+10

Information Processing Center

Information Processing Center

PLANE NUMBER 13

	1	2	3	4	5	6	7	8	9	10	11
1	4.528E+13	4.528E+13	4.528E+13	4.522E+13	4.516E+13	4.510E+13	4.510E+13	4.533E+13	4.557E+13	4.571E+13	4.572E+13
2	4.320E+13	4.320E+13	4.321E+13	4.342E+13	4.347E+13	4.395E+13	4.431E+13	4.485E+13	4.538E+13	4.567E+13	4.569E+13
3	4.287E+13	4.287E+13	4.287E+13	4.291E+13	4.281E+13	4.281E+13	4.347E+13	4.427E+13	4.502E+13	4.543E+13	4.545E+13
4	4.194E+13	4.193E+13	4.190E+13	4.190E+13	4.190E+13	4.196E+13	4.270E+13	4.363E+13	4.441E+13	4.487E+13	4.490E+13
5	4.099E+13	4.096E+13	4.061E+13	4.075E+13	4.085E+13	4.102E+13	4.198E+13	4.347E+13	4.405E+13	4.459E+13	4.462E+13
6	3.713E+13	3.709E+13	3.644E+13	3.781E+13	3.796E+13	3.811E+13	3.817E+13	4.041E+13	4.095E+13	4.172E+13	4.176E+13
7	3.121E+13	3.116E+13	3.039E+13	3.074E+13	3.077E+13	3.103E+13	3.202E+13	3.428E+13	3.459E+13	3.533E+13	3.531E+13
8	2.788E+13	2.786E+13	2.755E+13	2.772E+13	2.735E+13	2.810E+13	2.924E+13	3.076E+13	3.150E+13	3.205E+13	3.154E+13
9	2.772E+13	2.773E+13	2.784E+13	2.796E+13	2.724E+13	2.841E+13	2.967E+13	3.072E+13	3.192E+13	3.238E+13	3.144E+13
10	2.711E+13	2.712E+13	2.737E+13	2.751E+13	2.666E+13	2.795E+13	2.917E+13	3.005E+13	3.138E+13	3.185E+13	3.075E+13
11	2.656E+13	2.656E+13	2.594E+13	2.613E+13	2.611E+13	2.653E+13	2.763E+13	2.945E+13	2.971E+13	3.024E+13	3.010E+13
12	2.583E+13	2.581E+13	2.396E+13	2.426E+13	2.538E+13	2.462E+13	2.554E+13	2.864E+13	2.742E+13	2.807E+13	2.923E+13
13	2.450E+13	2.446E+13	2.148E+13	2.190E+13	2.409E+13	2.220E+13	2.290E+13	2.715E+13	2.454E+13	2.529E+13	2.769E+13
14	2.379E+13	2.363E+13	2.116E+13	2.162E+13	2.341E+13	2.194E+13	2.261E+13	2.636E+13	2.421E+13	2.499E+13	2.687E+13
15	2.202E+13	2.190E+13	2.018E+13	2.064E+13	2.178E+13	2.097E+13	2.162E+13	2.443E+13	2.313E+13	2.387E+13	2.500E+13
16	8.018E+12	8.012E+12	7.930E+12	8.261E+12	8.471E+12	8.648E+12	9.044E+12	9.444E+12	9.538E+12	9.741E+12	9.780E+12
17	1.658E+12	1.658E+12	1.657E+12	1.801E+12	1.965E+12	2.011E+12	2.085E+12	2.131E+12	2.179E+12	2.238E+12	2.256E+12
18	6.013E+11	6.013E+11	6.012E+11	6.623E+11	7.993E+11	7.829E+11	8.055E+11	8.053E+11	8.374E+11	8.642E+11	8.891E+11
19	1.833E+10	1.834E+10	1.840E+10	2.118E+10	2.655E+10	2.711E+10	2.751E+10	2.662E+10	2.841E+10	2.968E+10	3.055E+10

Information Processing Center

Information Processing Center

PLANE NUMBER 14

	1	2	3	4	5	6	7	8	9	10	11
1	3.924E+13	3.924E+13	3.924E+13	3.934E+13	3.940E+13	3.947E+13	3.968E+13	3.991E+13	4.014E+13	4.027E+13	4.027E+13
2	3.841E+13	3.841E+13	3.842E+13	3.857E+13	3.869E+13	3.881E+13	3.920E+13	3.966E+13	4.010E+13	4.034E+13	4.035E+13
3	3.795E+13	3.795E+13	3.795E+13	3.805E+13	3.812E+13	3.822E+13	3.876E+13	3.941E+13	4.004E+13	4.037E+13	4.039E+13
4	3.786E+13	3.786E+13	3.785E+13	3.791E+13	3.797E+13	3.806E+13	3.864E+13	3.941E+13	4.012E+13	4.051E+13	4.053E+13
5	3.632E+13	3.632E+13	3.625E+13	3.636E+13	3.643E+13	3.655E+13	3.721E+13	3.818E+13	3.896E+13	3.940E+13	3.943E+13
6	3.235E+13	3.233E+13	3.214E+13	3.264E+13	3.276E+13	3.274E+13	3.319E+13	3.465E+13	3.561E+13	3.623E+13	3.626E+13
7	2.724E+13	2.722E+13	2.692E+13	2.712E+13	2.707E+13	2.720E+13	2.806E+13	2.955E+13	3.041E+13	3.105E+13	3.105E+13
8	2.478E+13	2.476E+13	2.450E+13	2.468E+13	2.458E+13	2.484E+13	2.574E+13	2.702E+13	2.779E+13	2.836E+13	2.829E+13
9	2.394E+13	2.391E+13	2.356E+13	2.376E+13	2.374E+13	2.397E+13	2.486E+13	2.619E+13	2.678E+13	2.736E+13	2.734E+13
10	2.345E+13	2.341E+13	2.275E+13	2.300E+13	2.320E+13	2.322E+13	2.407E+13	2.572E+13	2.588E+13	2.646E+13	2.669E+13
11	2.312E+13	2.305E+13	2.209E+13	2.238E+13	2.285E+13	2.259E+13	2.339E+13	2.537E+13	2.512E+13	2.573E+13	2.626E+13
12	2.255E+13	2.245E+13	2.092E+13	2.129E+13	2.226E+13	2.151E+13	2.220E+13	2.480E+13	2.380E+13	2.447E+13	2.553E+13
13	2.231E+13	2.217E+13	2.018E+13	2.060E+13	2.197E+13	2.083E+13	2.145E+13	2.460E+13	2.295E+13	2.367E+13	2.515E+13
14	2.199E+13	2.186E+13	2.002E+13	2.045E+13	2.167E+13	2.069E+13	2.131E+13	2.426E+13	2.279E+13	2.351E+13	2.480E+13
15	2.037E+13	2.027E+13	1.887E+13	1.931E+13	2.016E+13	1.956E+13	2.016E+13	2.248E+13	2.153E+13	2.220E+13	2.307E+13
16	7.542E+12	7.537E+12	7.465E+12	7.816E+12	8.022E+12	8.222E+12	8.614E+12	8.978E+12	9.046E+12	9.244E+12	9.252E+12

Information Processing Center

Information Processing Center

17	1.576E+12	1.576E+12	1.576E+12	1.733E+12	1.926E+12	1.968E+12	2.038E+12	2.075E+12	2.121E+12	2.179E+12	2.200E+12
18	5.710E+11	5.710E+11	5.712E+11	6.393E+11	8.255E+11	7.885E+11	8.079E+11	7.963E+11	8.350E+11	8.634E+11	8.993E+11
19	1.769E+10	1.770E+10	1.776E+10	2.070E+10	2.670E+10	2.718E+10	2.751E+10	2.636E+10	2.832E+10	2.963E+10	3.064E+10

PLANE NUMBER 15

	1	2	3	4	5	6	7	8	9	10	11
1	3.342E+13	3.342E+13	3.344E+13	3.352E+13	3.358E+13	3.364E+13	3.382E+13	3.399E+13	3.417E+13	3.427E+13	3.427E+13
2	3.293E+13	3.293E+13	3.295E+13	3.301E+13	3.307E+13	3.313E+13	3.339E+13	3.371E+13	3.406E+13	3.424E+13	3.425E+13
3	3.247E+13	3.247E+13	3.247E+13	3.249E+13	3.252E+13	3.258E+13	3.289E+13	3.339E+13	3.389E+13	3.414E+13	3.416E+13
4	3.209E+13	3.209E+13	3.209E+13	3.208E+13	3.207E+13	3.209E+13	3.244E+13	3.304E+13	3.365E+13	3.396E+13	3.397E+13
5	3.107E+13	3.107E+13	3.106E+13	3.102E+13	3.093E+13	3.091E+13	3.126E+13	3.198E+13	3.273E+13	3.308E+13	3.308E+13
6	2.766E+13	2.765E+13	2.762E+13	2.759E+13	2.735E+13	2.724E+13	2.761E+13	2.864E+13	2.974E+13	3.022E+13	3.021E+13
7	2.165E+13	2.165E+13	2.157E+13	2.160E+13	2.118E+13	2.112E+13	2.169E+13	2.259E+13	2.387E+13	2.437E+13	2.435E+13
8	1.944E+13	1.943E+13	1.926E+13	1.941E+13	1.906E+13	1.911E+13	1.970E+13	2.042E+13	2.139E+13	2.187E+13	2.189E+13
9	1.877E+13	1.875E+13	1.850E+13	1.870E+13	1.838E+13	1.846E+13	1.904E+13	1.973E+13	2.055E+13	2.102E+13	2.109E+13
10	1.854E+13	1.851E+13	1.817E+13	1.842E+13	1.815E+13	1.821E+13	1.880E+13	1.954E+13	2.020E+13	2.068E+13	2.080E+13
11	1.844E+13	1.842E+13	1.800E+13	1.828E+13	1.806E+13	1.810E+13	1.868E+13	1.947E+13	2.003E+13	2.051E+13	2.068E+13
12	1.827E+13	1.823E+13	1.774E+13	1.805E+13	1.789E+13	1.790E+13	1.847E+13	1.933E+13	1.976E+13	2.025E+13	2.047E+13
13	1.803E+13	1.799E+13	1.740E+13	1.774E+13	1.768E+13	1.764E+13	1.820E+13	1.917E+13	1.942E+13	1.992E+13	2.021E+13
14	1.752E+13	1.748E+13	1.687E+13	1.724E+13	1.722E+13	1.718E+13	1.773E+13	1.871E+13	1.888E+13	1.937E+13	1.966E+13
15	1.647E+13	1.643E+13	1.587E+13	1.627E+13	1.626E+13	1.627E+13	1.680E+13	1.769E+13	1.783E+13	1.829E+13	1.853E+13
16	6.572E+12	6.569E+12	6.528E+12	6.928E+12	7.111E+12	7.390E+12	7.781E+12	8.068E+12	8.083E+12	8.206E+12	8.198E+12
17	1.410E+12	1.410E+12	1.412E+12	1.599E+12	1.876E+12	1.897E+12	1.958E+12	1.974E+12	2.018E+12	2.076E+12	2.109E+12
18	5.095E+11	5.096E+11	5.105E+11	5.959E+11	9.750E+11	8.470E+11	8.576E+11	8.050E+11	8.739E+11	9.088E+11	9.907E+11
19	1.636E+10	1.636E+10	1.644E+10	1.967E+10	2.716E+10	2.745E+10	2.762E+10	2.584E+10	2.823E+10	2.965E+10	3.100E+10

PLANE NUMBER 16

	1	2	3	4	5	6	7	8	9	10	11
1	3.011E+13	3.010E+13	2.991E+13	2.995E+13	2.999E+13	3.004E+13	3.024E+13	3.061E+13	3.057E+13	3.063E+13	3.063E+13
2	2.983E+13	2.982E+13	2.942E+13	2.942E+13	2.944E+13	2.948E+13	2.972E+13	3.044E+13	3.038E+13	3.053E+13	3.056E+13
3	2.898E+13	2.898E+13	2.895E+13	2.890E+13	2.887E+13	2.887E+13	2.913E+13	2.965E+13	3.013E+13	3.036E+13	3.037E+13
4	2.891E+13	2.891E+13	2.890E+13	2.879E+13	2.857E+13	2.850E+13	2.878E+13	2.939E+13	3.011E+13	3.040E+13	3.036E+13
5	2.762E+13	2.762E+13	2.761E+13	2.741E+13	2.650E+13	2.630E+13	2.656E+13	2.727E+13	2.847E+13	2.878E+13	2.850E+13
6	2.458E+13	2.457E+13	2.455E+13	2.439E+13	2.327E+13	2.306E+13	2.338E+13	2.427E+13	2.587E+13	2.629E+13	2.596E+13
7	1.879E+13	1.879E+13	1.876E+13	1.877E+13	1.726E+13	1.723E+13	1.765E+13	1.808E+13	2.033E+13	2.075E+13	2.051E+13
8	1.693E+13	1.693E+13	1.683E+13	1.703E+13	1.593E+13	1.621E+13	1.668E+13	1.674E+13	1.829E+13	1.867E+13	1.856E+13
9	1.661E+13	1.660E+13	1.646E+13	1.671E+13	1.549E+13	1.601E+13	1.650E+13	1.627E+13	1.773E+13	1.810E+13	1.807E+13
10	1.649E+13	1.647E+13	1.629E+13	1.658E+13	1.535E+13	1.590E+13	1.640E+13	1.617E+13	1.757E+13	1.793E+13	1.792E+13
11	1.639E+13	1.637E+13	1.614E+13	1.647E+13	1.526E+13	1.582E+13	1.632E+13	1.612E+13	1.744E+13	1.780E+13	1.780E+13
12	1.616E+13	1.615E+13	1.588E+13	1.624E+13	1.507E+13	1.562E+13	1.613E+13	1.596E+13	1.719E+13	1.755E+13	1.756E+13
13	1.580E+13	1.578E+13	1.547E+13	1.587E+13	1.477E+13	1.532E+13	1.582E+13	1.570E+13	1.680E+13	1.715E+13	1.717E+13
14	1.529E+13	1.527E+13	1.494E+13	1.538E+13	1.440E+13	1.492E+13	1.542E+13	1.535E+13	1.630E+13	1.663E+13	1.665E+13
15	1.438E+13	1.436E+13	1.405E+13	1.452E+13	1.378E+13	1.423E+13	1.473E+13	1.474E+13	1.545E+13	1.575E+13	1.575E+13
16	5.913E+12	5.912E+12	5.889E+12	6.347E+12	6.479E+12	6.877E+12	7.275E+12	7.530E+12	7.475E+12	7.557E+12	7.499E+12
17	1.293E+12	1.293E+12	1.296E+12	1.507E+12	1.894E+12	1.873E+12	1.926E+12	1.923E+12	1.969E+12	2.030E+12	2.079E+12
18	4.661E+11	4.662E+11	4.677E+11	5.699E+11	1.375E+12	1.022E+12	1.021E+12	8.846E+11	1.027E+12	1.075E+12	1.265E+12
19	1.537E+10	1.538E+10	1.546E+10	1.887E+10	2.756E+10	2.774E+10	2.779E+10	2.541E+10	2.827E+10	2.977E+10	3.141E+10

PLANE NUMBER 17

	1	2	3	4	5	6	7	8	9	10	11
1	2.542E+13	2.542E+13	2.541E+13	2.543E+13	2.545E+13	2.548E+13	2.558E+13	2.573E+13	2.586E+13	2.593E+13	2.593E+13
2	2.498E+13	2.497E+13	2.495E+13	2.486E+13	2.483E+13	2.481E+13	2.492E+13	2.525E+13	2.553E+13	2.568E+13	2.569E+13
3	2.445E+13	2.444E+13	2.443E+13	2.423E+13	2.409E+13	2.399E+13	2.410E+13	2.457E+13	2.508E+13	2.530E+13	2.531E+13
4	2.391E+13	2.391E+13	2.390E+13	2.358E+13	2.314E+13	2.294E+13	2.305E+13	2.364E+13	2.446E+13	2.472E+13	2.468E+13
5	2.327E+13	2.327E+13	2.325E+13	2.286E+13	2.230E+13	2.209E+13	2.221E+13	2.285E+13	2.385E+13	2.414E+13	2.409E+13
6	2.088E+13	2.087E+13	2.086E+13	2.052E+13	1.970E+13	1.946E+13	1.968E+13	2.042E+13	2.190E+13	2.228E+13	2.221E+13
7	1.695E+13	1.695E+13	1.694E+13	1.695E+13	1.602E+13	1.606E+13	1.641E+13	1.663E+13	1.837E+13	1.874E+13	1.868E+13
8	1.537E+13	1.537E+13	1.534E+13	1.562E+13	1.511E+13	1.544E+13	1.586E+13	1.575E+13	1.678E+13	1.709E+13	1.713E+13
9	1.482E+13	1.482E+13	1.478E+13	1.514E+13	1.475E+13	1.515E+13	1.559E+13	1.542E+13	1.625E+13	1.654E+13	1.659E+13
10	1.443E+13	1.443E+13	1.438E+13	1.480E+13	1.448E+13	1.487E+13	1.532E+13	1.518E+13	1.591E+13	1.618E+13	1.621E+13
11	1.413E+13	1.413E+13	1.407E+13	1.453E+13	1.428E+13	1.465E+13	1.511E+13	1.500E+13	1.564E+13	1.591E+13	1.592E+13
12	1.377E+13	1.376E+13	1.370E+13	1.420E+13	1.403E+13	1.439E+13	1.486E+13	1.477E+13	1.531E+13	1.557E+13	1.557E+13
13	1.330E+13	1.329E+13	1.321E+13	1.377E+13	1.372E+13	1.406E+13	1.453E+13	1.449E+13	1.489E+13	1.512E+13	1.512E+13

Information Processing Center

Information Processing Center

14	1.278E+13	1.277E+13	1.269E+13	1.328E+13	1.340E+13	1.370E+13	1.418E+13	1.420E+13	1.442E+13	1.464E+13	1.461E+13
15	1.197E+13	1.196E+13	1.188E+13	1.251E+13	1.293E+13	1.316E+13	1.364E+13	1.375E+13	1.369E+13	1.389E+13	1.383E+13
16	5.113E+12	5.113E+12	5.111E+12	5.647E+12	6.126E+12	6.479E+12	6.883E+12	7.247E+12	7.001E+12	7.049E+12	7.015E+12
17	1.149E+12	1.149E+12	1.154E+12	1.395E+12	1.905E+12	1.856E+12	1.902E+12	1.866E+12	1.930E+12	1.993E+12	2.067E+12
18	4.130E+11	4.132E+11	4.153E+11	5.377E+11	1.526E+12	1.170E+12	1.162E+12	9.818E+11	1.165E+12	1.223E+12	1.421E+12
19	1.415E+10	1.415E+10	1.425E+10	1.786E+10	2.794E+10	2.796E+10	2.791E+10	2.484E+10	2.827E+10	2.984E+10	3.172E+10

PLANE NUMBER 18

	1	2	3	4	5	6	7	8	9	10	11
1	1.962E+13	1.962E+13	1.962E+13	1.969E+13	1.972E+13	1.976E+13	1.988E+13	1.999E+13	2.009E+13	2.014E+13	2.014E+13
2	1.923E+13	1.923E+13	1.923E+13	1.931E+13	1.935E+13	1.940E+13	1.957E+13	1.976E+13	1.995E+13	2.005E+13	2.005E+13
3	1.881E+13	1.881E+13	1.882E+13	1.891E+13	1.894E+13	1.899E+13	1.919E+13	1.947E+13	1.975E+13	1.989E+13	1.990E+13
4	1.839E+13	1.839E+13	1.840E+13	1.852E+13	1.850E+13	1.854E+13	1.877E+13	1.909E+13	1.949E+13	1.966E+13	1.966E+13
5	1.792E+13	1.792E+13	1.793E+13	1.810E+13	1.816E+13	1.821E+13	1.846E+13	1.880E+13	1.925E+13	1.946E+13	1.948E+13
6	1.617E+13	1.618E+13	1.620E+13	1.657E+13	1.670E+13	1.679E+13	1.712E+13	1.750E+13	1.813E+13	1.840E+13	1.844E+13
7	1.348E+13	1.348E+13	1.352E+13	1.431E+13	1.483E+13	1.503E+13	1.543E+13	1.548E+13	1.581E+13	1.603E+13	1.608E+13
8	1.213E+13	1.213E+13	1.216E+13	1.312E+13	1.400E+13	1.443E+13	1.487E+13	1.469E+13	1.451E+13	1.467E+13	1.478E+13
9	1.161E+13	1.161E+13	1.164E+13	1.265E+13	1.364E+13	1.407E+13	1.452E+13	1.436E+13	1.404E+13	1.419E+13	1.429E+13
10	1.124E+13	1.124E+13	1.127E+13	1.231E+13	1.338E+13	1.374E+13	1.419E+13	1.413E+13	1.374E+13	1.386E+13	1.393E+13
11	1.096E+13	1.096E+13	1.098E+13	1.204E+13	1.317E+13	1.349E+13	1.394E+13	1.394E+13	1.349E+13	1.361E+13	1.366E+13
12	1.062E+13	1.062E+13	1.065E+13	1.172E+13	1.293E+13	1.320E+13	1.366E+13	1.372E+13	1.319E+13	1.330E+13	1.333E+13
13	1.020E+13	1.020E+13	1.022E+13	1.131E+13	1.263E+13	1.285E+13	1.331E+13	1.344E+13	1.281E+13	1.290E+13	1.292E+13
14	9.763E+12	9.764E+12	9.785E+12	1.088E+13	1.232E+13	1.249E+13	1.295E+13	1.316E+13	1.239E+13	1.247E+13	1.248E+13
15	9.109E+12	9.111E+12	9.130E+12	1.021E+13	1.188E+13	1.197E+13	1.242E+13	1.275E+13	1.176E+13	1.183E+13	1.180E+13
16	4.009E+12	4.010E+12	4.027E+12	4.673E+12	5.545E+12	5.815E+12	6.201E+12	6.685E+12	6.211E+12	6.227E+12	6.240E+12
17	9.352E+11	9.357E+11	9.428E+11	1.207E+12	1.846E+12	1.728E+12	1.761E+12	1.682E+12	1.769E+12	1.832E+12	1.950E+12
18	3.347E+11	3.348E+11	3.376E+11	4.686E+11	1.512E+12	1.130E+12	1.115E+12	7.298E+11	1.109E+12	1.169E+12	1.385E+12
19	1.216E+10	1.217E+10	1.226E+10	1.595E+10	2.654E+10	2.686E+10	2.674E+10	2.256E+10	2.697E+10	2.854E+10	3.051E+10

PLANE NUMBER 19

	1	2	3	4	5	6	7	8	9	10	11
1	1.551E+13	1.551E+13	1.551E+13	1.560E+13	1.565E+13	1.571E+13	1.583E+13	1.592E+13	1.599E+13	1.603E+13	1.603E+13
2	1.518E+13	1.518E+13	1.519E+13	1.536E+13	1.544E+13	1.553E+13	1.574E+13	1.586E+13	1.597E+13	1.603E+13	1.603E+13
3	1.483E+13	1.483E+13	1.485E+13	1.510E+13	1.523E+13	1.536E+13	1.563E+13	1.578E+13	1.591E+13	1.598E+13	1.599E+13
4	1.450E+13	1.450E+13	1.451E+13	1.484E+13	1.503E+13	1.521E+13	1.553E+13	1.568E+13	1.581E+13	1.590E+13	1.591E+13
5	1.412E+13	1.412E+13	1.414E+13	1.456E+13	1.482E+13	1.505E+13	1.543E+13	1.558E+13	1.570E+13	1.580E+13	1.582E+13
6	1.277E+13	1.277E+13	1.280E+13	1.348E+13	1.393E+13	1.429E+13	1.478E+13	1.491E+13	1.498E+13	1.512E+13	1.516E+13
7	1.072E+13	1.073E+13	1.078E+13	1.178E+13	1.263E+13	1.317E+13	1.369E+13	1.361E+13	1.329E+13	1.337E+13	1.343E+13
8	9.625E+12	9.629E+12	9.676E+12	1.076E+13	1.178E+13	1.235E+13	1.287E+13	1.278E+13	1.227E+13	1.233E+13	1.238E+13
9	9.199E+12	9.202E+12	9.249E+12	1.035E+13	1.143E+13	1.199E+13	1.251E+13	1.244E+13	1.188E+13	1.192E+13	1.196E+13
10	8.896E+12	8.899E+12	8.945E+12	1.006E+13	1.117E+13	1.171E+13	1.223E+13	1.219E+13	1.159E+13	1.163E+13	1.166E+13
11	8.661E+12	8.664E+12	8.709E+12	9.826E+12	1.096E+13	1.149E+13	1.200E+13	1.199E+13	1.136E+13	1.139E+13	1.143E+13
12	8.386E+12	8.389E+12	8.434E+12	9.549E+12	1.072E+13	1.123E+13	1.173E+13	1.174E+13	1.109E+13	1.111E+13	1.114E+13
13	8.042E+12	8.045E+12	8.088E+12	9.197E+12	1.039E+13	1.088E+13	1.138E+13	1.143E+13	1.073E+13	1.076E+13	1.078E+13
14	7.691E+12	7.694E+12	7.736E+12	8.828E+12	1.005E+13	1.051E+13	1.100E+13	1.108E+13	1.036E+13	1.038E+13	1.040E+13
15	7.170E+12	7.173E+12	7.213E+12	8.271E+12	9.508E+12	9.939E+12	1.041E+13	1.054E+13	9.797E+12	9.808E+12	9.827E+12
16	3.211E+12	3.212E+12	3.234E+12	3.848E+12	4.596E+12	4.879E+12	5.218E+12	5.563E+12	5.177E+12	5.180E+12	5.212E+12
17	7.679E+11	7.684E+11	7.757E+11	1.015E+12	1.518E+12	1.450E+12	1.478E+12	1.408E+12	1.476E+12	1.530E+12	1.628E+12
18	2.738E+11	2.740E+11	2.768E+11	3.843E+11	8.892E+11	7.153E+11	7.113E+11	5.558E+11	7.042E+11	7.404E+11	8.554E+11
19	1.039E+10	1.039E+10	1.049E+10	1.391E+10	2.297E+10	2.366E+10	2.354E+10	1.968E+10	2.370E+10	2.510E+10	2.676E+10

PLANE NUMBER 20

	1	2	3	4	5	6	7	8	9	10	11
1	1.200E+12	1.200E+12	1.200E+12	1.208E+12	1.212E+12	1.216E+12	1.225E+12	1.231E+12	1.236E+12	1.239E+12	1.239E+12
2	1.176E+12	1.176E+12	1.177E+12	1.190E+12	1.197E+12	1.204E+12	1.220E+12	1.228E+12	1.234E+12	1.237E+12	1.238E+12
3	1.151E+12	1.151E+12	1.152E+12	1.172E+12	1.181E+12	1.191E+12	1.213E+12	1.222E+12	1.230E+12	1.233E+12	1.233E+12
4	1.127E+12	1.127E+12	1.128E+12	1.153E+12	1.166E+12	1.178E+12	1.204E+12	1.213E+12	1.221E+12	1.224E+12	1.224E+12
5	1.100E+12	1.100E+12	1.102E+12	1.133E+12	1.148E+12	1.163E+12	1.194E+12	1.203E+12	1.210E+12	1.213E+12	1.213E+12
6	1.005E+12	1.005E+12	1.008E+12	1.058E+12	1.082E+12	1.106E+12	1.149E+12	1.156E+12	1.161E+12	1.162E+12	1.163E+12
7	8.615E+11	8.618E+11	8.654E+11	9.339E+11	9.687E+11	1.002E+12	1.054E+12	1.054E+12	1.049E+12	1.048E+12	1.048E+12
8	7.801E+11	7.804E+11	7.842E+11	8.574E+11	8.958E+11	9.314E+11	9.843E+11	9.822E+11	9.732E+11	9.716E+11	9.716E+11
9	7.484E+11	7.486E+11	7.525E+11	8.269E+11	8.668E+11	9.029E+11	9.532E+11	9.532E+11	9.429E+11	9.410E+11	9.410E+11
10	7.257E+11	7.260E+11	7.299E+11	8.049E+11	8.452E+11	8.818E+11	9.347E+11	9.318E+11	9.207E+11	9.186E+11	9.186E+11

Information Processing Center

Information Processing Center

Information Processing Center

Information Processing Center

11	7.081E+11	7.084E+11	7.123E+11	7.876E+11	8.283E+11	8.652E+11	9.178E+11	9.148E+11	9.032E+11	9.010E+11	9.010E+11
12	6.876E+11	6.878E+11	6.917E+11	7.671E+11	8.083E+11	8.452E+11	8.975E+11	8.945E+11	8.824E+11	8.800E+11	8.800E+11
13	6.618E+11	6.621E+11	6.659E+11	7.412E+11	7.828E+11	8.197E+11	8.715E+11	8.685E+11	8.558E+11	8.534E+11	8.534E+11
14	6.356E+11	6.359E+11	6.397E+11	7.144E+11	7.560E+11	7.928E+11	8.438E+11	8.411E+11	8.281E+11	8.256E+11	8.256E+11
15	5.967E+11	5.970E+11	6.007E+11	6.741E+11	7.157E+11	7.520E+11	8.017E+11	7.995E+11	7.862E+11	7.838E+11	7.838E+11
16	3.021E+11	3.023E+11	3.050E+11	3.612E+11	3.962E+11	4.252E+11	4.614E+11	4.656E+11	4.556E+11	4.541E+11	4.544E+11
17	8.403E+10	8.411E+10	8.513E+10	1.083E+11	1.277E+11	1.369E+11	1.453E+11	1.436E+11	1.440E+11	1.464E+11	1.480E+11
18	2.925E+10	2.927E+10	2.965E+10	3.852E+10	4.819E+10	5.064E+10	5.341E+10	5.178E+10	5.270E+10	5.382E+10	5.498E+10
19	1.743E+09	1.745E+09	1.769E+09	2.410E+09	3.193E+09	3.478E+09	3.552E+09	3.312E+09	3.547E+09	3.719E+09	3.807E+09

Information Processing Center

GROUP 3 FLUX

PLANE NUMBER 1

	1	2	3	4	5	6	7	8	9	10	11
1	1.435E+12	1.435E+12	1.435E+12	1.440E+12	1.443E+12	1.446E+12	1.454E+12	1.460E+12	1.465E+12	1.468E+12	1.468E+12
2	1.407E+12	1.407E+12	1.407E+12	1.415E+12	1.420E+12	1.424E+12	1.436E+12	1.445E+12	1.455E+12	1.460E+12	1.461E+12
3	1.376E+12	1.376E+12	1.377E+12	1.388E+12	1.394E+12	1.400E+12	1.414E+12	1.427E+12	1.440E+12	1.448E+12	1.448E+12
4	1.345E+12	1.345E+12	1.346E+12	1.361E+12	1.367E+12	1.374E+12	1.389E+12	1.405E+12	1.420E+12	1.430E+12	1.431E+12
5	1.310E+12	1.310E+12	1.311E+12	1.328E+12	1.336E+12	1.343E+12	1.359E+12	1.377E+12	1.396E+12	1.408E+12	1.409E+12
6	1.171E+12	1.172E+12	1.175E+12	1.203E+12	1.213E+12	1.221E+12	1.237E+12	1.263E+12	1.287E+12	1.307E+12	1.309E+12
7	8.494E+11	8.511E+11	8.756E+11	9.060E+11	9.278E+11	9.222E+11	9.337E+11	9.889E+11	9.824E+11	1.008E+12	1.021E+12
8	4.423E+11	4.503E+11	5.622E+11	5.928E+11	6.853E+11	6.036E+11	6.060E+11	7.722E+11	6.394E+11	6.641E+11	7.469E+11
9	2.146E+11	2.260E+11	4.062E+11	4.335E+11	5.870E+11	4.414E+11	4.405E+11	6.861E+11	4.653E+11	4.871E+11	6.325E+11
10	2.467E+08	3.361E+08	2.649E+11	2.855E+11	5.186E+11	2.907E+11	2.885E+11	6.260E+11	3.049E+11	3.216E+11	5.504E+11
11	1.436E+10	1.140E+08	1.414E+11	1.543E+11	4.686E+11	1.571E+11	1.546E+11	5.812E+11	1.636E+11	1.744E+11	4.894E+11
12	1.116E+08	1.383E+08	3.294E+10	3.698E+10	4.201E+11	3.764E+10	3.639E+10	5.342E+11	3.855E+10	4.226E+10	4.281E+11
13	1.476E+11	1.468E+11	1.359E+11	1.478E+11	4.199E+11	1.506E+11	1.477E+11	5.280E+11	1.570E+11	1.689E+11	4.395E+11
14	2.404E+11	2.394E+11	2.243E+11	2.405E+11	4.255E+11	2.450E+11	2.427E+11	5.234E+11	2.582E+11	2.748E+11	4.545E+11
15	3.228E+11	3.216E+11	3.054E+11	3.236E+11	4.294E+11	3.299E+11	3.293E+11	5.122E+11	3.506E+11	3.700E+11	4.683E+11
16	2.401E+11	2.400E+11	2.388E+11	2.447E+11	2.498E+11	2.500E+11	2.566E+11	2.706E+11	2.743E+11	2.823E+11	2.850E+11
17	5.481E+10	5.480E+10	5.475E+10	5.602E+10	5.673E+10	5.737E+10	5.915E+10	6.125E+10	6.309E+10	6.464E+10	6.478E+10
18	1.283E+11	1.283E+11	1.285E+11	1.321E+11	1.340E+11	1.359E+11	1.406E+11	1.447E+11	1.486E+11	1.512E+11	1.514E+11
19	4.212E+11	4.213E+11	4.220E+11	4.347E+11	4.413E+11	4.481E+11	4.639E+11	4.765E+11	4.886E+11	4.961E+11	4.965E+11

PLANE NUMBER 2

Information Processing Center

	1	2	3	4	5	6	7	8	9	10	11
1	2.088E+13	2.088E+13	2.088E+13	2.098E+13	2.104E+13	2.111E+13	2.125E+13	2.134E+13	2.143E+13	2.148E+13	2.148E+13
2	2.046E+13	2.046E+13	2.047E+13	2.062E+13	2.067E+13	2.076E+13	2.093E+13	2.108E+13	2.123E+13	2.132E+13	2.133E+13
3	1.984E+13	1.984E+13	1.986E+13	2.008E+13	2.023E+13	2.035E+13	2.056E+13	2.075E+13	2.096E+13	2.111E+13	2.112E+13
4	1.937E+13	1.937E+13	1.945E+13	1.971E+13	1.982E+13	1.995E+13	2.016E+13	2.033E+13	2.064E+13	2.085E+13	2.084E+13
5	1.883E+13	1.884E+13	1.896E+13	1.928E+13	1.940E+13	1.951E+13	1.971E+13	1.987E+13	2.029E+13	2.056E+13	2.057E+13
6	1.669E+13	1.671E+13	1.695E+13	1.734E+13	1.749E+13	1.761E+13	1.791E+13	1.810E+13	1.871E+13	1.918E+13	1.922E+13
7	1.146E+13	1.150E+13	1.215E+13	1.283E+13	1.320E+13	1.308E+13	1.308E+13	1.369E+13	1.382E+13	1.439E+13	1.461E+13
8	5.864E+12	5.980E+12	7.612E+12	8.269E+12	9.716E+12	8.435E+12	8.328E+12	1.080E+13	8.821E+12	9.336E+12	1.065E+13
9	3.052E+12	3.203E+12	5.512E+12	6.092E+12	8.416E+12	6.216E+12	6.085E+12	9.801E+12	6.453E+12	6.904E+12	9.135E+12
10	5.249E+09	7.861E+09	3.754E+12	4.206E+12	7.633E+12	4.292E+12	4.171E+12	9.227E+12	4.427E+12	4.779E+12	8.202E+12
11	1.482E+11	2.715E+09	2.271E+12	2.582E+12	7.107E+12	2.635E+12	2.540E+12	8.842E+12	2.697E+12	2.944E+12	7.570E+12
12	2.501E+09	3.254E+09	7.749E+11	8.997E+11	6.694E+12	9.188E+11	8.754E+11	8.528E+12	9.309E+11	1.035E+12	7.067E+12
13	2.365E+12	2.362E+12	2.321E+12	2.635E+12	6.826E+12	2.695E+12	2.605E+12	8.622E+12	2.777E+12	3.042E+12	7.305E+12
14	3.666E+12	3.669E+12	3.700E+12	4.129E+12	7.086E+12	4.228E+12	4.137E+12	8.765E+12	4.413E+12	4.770E+12	7.686E+12
15	5.031E+12	5.037E+12	5.121E+12	5.628E+12	7.437E+12	5.766E+12	5.700E+12	8.928E+12	6.082E+12	6.501E+12	8.189E+12
16	7.399E+12	7.401E+12	7.442E+12	7.714E+12	7.871E+12	7.915E+12	8.126E+12	8.524E+12	8.662E+12	8.906E+12	8.968E+12
17	2.679E+12	2.679E+12	2.685E+12	2.760E+12	2.797E+12	2.831E+12	2.920E+12	3.019E+12	3.107E+12	3.178E+12	3.184E+12
18	1.539E+12	1.539E+12	1.542E+12	1.585E+12	1.606E+12	1.627E+12	1.680E+12	1.734E+12	1.785E+12	1.823E+12	1.826E+12
19	1.222E+12	1.222E+12	1.224E+12	1.263E+12	1.283E+12	1.303E+12	1.349E+12	1.387E+12	1.423E+12	1.446E+12	1.447E+12

PLANE NUMBER 3

	1	2	3	4	5	6	7	8	9	10	11
1	8.043E+12	8.043E+12	8.035E+12	7.892E+12	7.810E+12	7.252E+12	6.270E+12	6.055E+12	5.893E+12	5.858E+12	5.857E+12
2	1.025E+13	1.024E+13	1.021E+13	9.558E+12	7.259E+12	6.113E+12	5.228E+12	5.189E+12	5.134E+12	5.193E+12	5.205E+12
3	4.300E+12	4.297E+12	4.260E+12	4.271E+12	4.413E+12	4.218E+12	3.965E+12	4.190E+12	4.049E+12	4.202E+12	4.306E+12

Information Processing Center

Information Processing Center

4	4.032E+12	4.023E+12	2.860E+12	2.958E+12	3.582E+12	2.263E+12	2.017E+12	3.308E+12	2.097E+12	2.311E+12	3.457E+12
5	3.879E+12	3.881E+12	4.200E+12	4.497E+12	4.532E+12	4.339E+12	3.992E+12	3.323E+12	4.235E+12	4.601E+12	4.739E+12
6	1.368E+12	1.467E+12	4.907E+12	4.978E+12	4.984E+12	4.985E+12	5.203E+12	1.456E+12	5.694E+12	6.364E+12	6.405E+12
7	6.392E+11	7.336E+11	4.034E+12	4.536E+12	4.718E+12	4.619E+12	4.374E+12	8.688E+11	4.757E+12	5.332E+12	5.465E+12
8	4.777E+11	5.452E+11	2.476E+12	3.116E+12	4.437E+12	3.202E+12	2.858E+12	1.662E+12	3.091E+12	3.691E+12	4.806E+12
9	4.961E+11	7.951E+11	1.840E+12	2.565E+12	4.653E+12	2.650E+12	2.248E+12	2.698E+12	2.420E+12	3.059E+12	4.859E+12
10	3.050E+09	1.663E+10	1.772E+12	2.454E+12	7.815E+12	2.537E+12	2.174E+12	7.101E+12	2.338E+12	2.938E+12	7.880E+12
11	1.239E+12	1.897E+10	1.721E+12	2.365E+12	1.285E+13	2.445E+12	2.113E+12	1.310E+13	2.272E+12	2.836E+12	1.279E+13
12	1.752E+10	1.833E+10	1.497E+12	1.872E+12	1.739E+13	1.933E+12	1.785E+12	1.890E+13	1.911E+12	2.220E+12	1.860E+13
13	9.139E+12	9.178E+12	1.173E+13	1.305E+13	1.919E+13	1.347E+13	1.348E+13	2.104E+13	1.440E+13	1.517E+13	2.135E+13
14	1.006E+13	1.045E+13	1.655E+13	1.835E+13	1.941E+13	1.898E+13	1.921E+13	2.127E+13	2.044E+13	2.122E+13	2.166E+13
15	1.313E+13	1.347E+13	1.828E+13	2.010E+13	2.099E+13	2.078E+13	2.108E+13	2.292E+13	2.243E+13	2.323E+13	2.356E+13
16	3.046E+13	3.049E+13	3.096E+13	3.223E+13	3.273E+13	3.315E+13	3.414E+13	3.531E+13	3.625E+13	3.707E+13	3.713E+13
17	2.134E+13	2.135E+13	2.142E+13	2.207E+13	2.237E+13	2.266E+13	2.339E+13	2.412E+13	2.481E+13	2.530E+13	2.533E+13
18	1.066E+13	1.066E+13	1.069E+13	1.101E+13	1.115E+13	1.130E+13	1.166E+13	1.203E+13	1.238E+13	1.264E+13	1.265E+13
19	1.799E+12	1.799E+12	1.802E+12	1.860E+12	1.891E+12	1.921E+12	1.989E+12	2.044E+12	2.098E+12	2.132E+12	2.134E+12

PLANE NUMBER 4

1	1.231E+13	1.231E+13	1.230E+13	1.210E+13	1.198E+13	1.125E+13	9.997E+12	9.760E+12	9.590E+12	9.570E+12	9.569E+12
2	1.619E+13	1.619E+13	1.614E+13	1.506E+13	1.121E+13	9.557E+12	8.393E+12	8.401E+12	8.383E+12	8.507E+12	8.527E+12
3	6.542E+12	6.538E+12	6.485E+12	6.489E+12	6.766E+12	6.589E+12	6.367E+12	6.750E+12	6.605E+12	6.879E+12	7.044E+12
4	6.119E+12	6.106E+12	4.397E+12	4.445E+12	5.353E+12	3.411E+12	3.196E+12	5.159E+12	3.384E+12	3.751E+12	5.587E+12
5	5.884E+12	5.888E+12	6.601E+12	6.665E+12	6.706E+12	6.444E+12	6.404E+12	5.169E+12	6.936E+12	7.578E+12	7.797E+12
6	2.051E+12	2.214E+12	7.836E+12	6.820E+12	6.821E+12	6.835E+12	8.393E+12	2.234E+12	9.417E+12	1.056E+13	1.063E+13
7	9.283E+11	1.082E+12	6.474E+12	7.072E+12	7.351E+12	7.217E+12	7.067E+12	1.281E+12	7.781E+12	8.729E+12	8.942E+12
8	6.920E+11	7.969E+11	3.827E+12	4.741E+12	6.756E+12	4.879E+12	4.427E+12	2.480E+12	4.829E+12	5.759E+12	7.498E+12
9	7.275E+11	1.177E+12	2.747E+12	3.801E+12	6.978E+12	3.930E+12	3.362E+12	4.067E+12	3.643E+12	4.614E+12	7.415E+12
10	4.745E+09	2.475E+10	2.638E+12	3.629E+12	1.183E+13	3.755E+12	3.243E+12	1.084E+13	3.511E+12	4.419E+12	1.212E+13
11	2.010E+12	2.895E+10	2.560E+12	3.494E+12	1.931E+13	3.616E+12	3.149E+12	1.978E+13	3.406E+12	4.259E+12	1.945E+13
12	2.515E+10	2.622E+10	2.224E+12	2.763E+12	2.546E+13	2.855E+12	2.653E+12	2.775E+13	2.854E+12	3.316E+12	2.745E+13
13	1.301E+13	1.307E+13	1.739E+13	1.924E+13	2.746E+13	1.986E+13	1.998E+13	3.017E+13	2.142E+13	2.254E+13	3.071E+13
14	1.434E+13	1.490E+13	2.385E+13	2.635E+13	2.776E+13	2.725E+13	2.769E+13	3.048E+13	2.954E+13	3.062E+13	3.113E+13
15	1.877E+13	1.927E+13	2.634E+13	2.885E+13	3.004E+13	2.983E+13	3.038E+13	3.288E+13	3.239E+13	3.350E+13	3.388E+13
16	4.323E+13	4.328E+13	4.396E+13	4.567E+13	4.636E+13	4.697E+13	4.844E+13	5.012E+13	5.148E+13	5.261E+13	5.269E+13
17	2.857E+13	2.858E+13	2.868E+13	2.950E+13	2.989E+13	3.028E+13	3.128E+13	3.226E+13	3.318E+13	3.382E+13	3.386E+13
18	1.468E+13	1.469E+13	1.473E+13	1.514E+13	1.534E+13	1.554E+13	1.657E+13	1.657E+13	1.705E+13	1.739E+13	1.741E+13
19	2.264E+12	2.264E+12	2.269E+12	2.345E+12	2.386E+12	2.427E+12	2.513E+12	2.582E+12	2.649E+12	2.693E+12	2.696E+12

PLANE NUMBER 5

1	1.860E+13	1.860E+13	1.859E+13	1.828E+13	1.810E+13	1.694E+13	1.494E+13	1.456E+13	1.428E+13	1.424E+13	1.424E+13
2	2.463E+13	2.462E+13	2.455E+13	2.282E+13	1.698E+13	1.441E+13	1.256E+13	1.258E+13	1.254E+13	1.271E+13	1.274E+13
3	1.055E+13	1.054E+13	1.045E+13	1.035E+13	1.057E+13	9.995E+12	9.583E+12	1.025E+13	9.947E+12	1.034E+13	1.061E+13
4	9.883E+12	9.861E+12	7.007E+12	6.972E+12	8.310E+12	5.145E+12	4.850E+12	8.242E+12	5.145E+12	5.674E+12	8.566E+12
5	9.478E+12	9.481E+12	9.960E+12	9.755E+12	9.801E+12	9.355E+12	9.551E+12	8.286E+12	1.038E+13	1.125E+13	1.160E+13
6	3.252E+12	3.478E+12	1.132E+13	9.613E+12	9.612E+12	9.634E+12	1.219E+13	3.598E+12	1.373E+13	1.527E+13	1.536E+13
7	1.542E+12	1.755E+12	9.232E+12	9.962E+12	1.035E+13	1.018E+13	1.013E+13	2.212E+12	1.118E+13	1.241E+13	1.270E+13
8	1.107E+12	1.249E+12	5.388E+12	6.580E+12	9.351E+12	6.779E+12	6.256E+12	3.762E+12	6.835E+12	8.048E+12	1.046E+13
9	1.099E+12	1.706E+12	3.828E+12	5.224E+12	9.590E+12	5.406E+12	4.702E+12	5.888E+12	5.101E+12	6.376E+12	1.026E+13
10	6.936E+09	3.457E+10	3.666E+12	4.977E+12	1.617E+13	5.154E+12	4.522E+12	1.520E+13	4.901E+12	6.092E+12	1.667E+13
11	2.873E+12	4.050E+10	3.548E+12	4.782E+12	2.613E+13	4.953E+12	4.379E+12	2.722E+13	4.741E+12	5.859E+12	2.645E+13
12	3.322E+10	3.456E+10	3.022E+12	3.728E+12	3.389E+13	3.854E+12	3.613E+12	3.736E+13	3.892E+12	4.493E+12	3.664E+13
13	1.709E+13	1.716E+13	2.325E+13	2.558E+13	3.608E+13	2.641E+13	2.671E+13	3.999E+13	2.867E+13	3.007E+13	4.042E+13
14	1.882E+13	1.957E+13	3.138E+13	3.452E+13	3.643E+13	3.570E+13	3.639E+13	4.036E+13	3.886E+13	4.019E+13	4.093E+13
15	2.454E+13	2.521E+13	3.451E+13	3.767E+13	3.927E+13	3.893E+13	3.977E+13	4.331E+13	4.244E+13	4.380E+13	4.435E+13
16	5.501E+13	5.507E+13	5.593E+13	5.794E+13	5.881E+13	5.956E+13	6.150E+13	6.367E+13	6.537E+13	6.673E+13	6.684E+13
17	3.502E+13	3.502E+13	3.515E+13	3.609E+13	3.655E+13	3.703E+13	3.827E+13	3.946E+13	4.058E+13	4.133E+13	4.138E+13
18	1.809E+13	1.809E+13	1.814E+13	1.861E+13	1.885E+13	1.910E+13	1.975E+13	2.038E+13	2.097E+13	2.137E+13	2.140E+13
19	2.620E+12	2.621E+12	2.626E+12	2.718E+12	2.770E+12	2.820E+12	2.920E+12	3.000E+12	3.078E+12	3.128E+12	3.131E+12

PLANE NUMBER 6

1	2	3	4	5	6	7	8	9	10	11
---	---	---	---	---	---	---	---	---	----	----

Information Processing Center

Information Processing Center

Information Processing Center

Information Processing Center

1	2.853E+13	2.852E+13	2.850E+13	2.807E+13	2.783E+13	2.613E+13	2.326E+13	2.276E+13	2.241E+13	2.236E+13	2.236E+13
2	4.126E+13	4.126E+13	4.124E+13	3.780E+13	2.729E+13	2.401E+13	2.171E+13	2.173E+13	2.191E+13	2.211E+13	2.212E+13
3	2.305E+13	2.306E+13	2.325E+13	2.251E+13	2.204E+13	2.088E+13	2.050E+13	2.076E+13	2.139E+13	2.176E+13	2.177E+13
4	2.170E+13	2.177E+13	2.278E+13	2.182E+13	2.065E+13	1.995E+13	1.991E+13	1.968E+13	2.087E+13	2.130E+13	2.125E+13
5	1.958E+13	1.958E+13	1.968E+13	1.754E+13	1.723E+13	1.716E+13	1.939E+13	1.912E+13	2.086E+13	2.148E+13	2.151E+13
6	1.508E+13	1.509E+13	1.631E+13	1.350E+13	1.350E+13	1.354E+13	1.781E+13	1.836E+13	1.992E+13	2.080E+13	2.086E+13
7	1.054E+13	1.055E+13	1.266E+13	1.302E+13	1.347E+13	1.334E+13	1.413E+13	1.783E+13	1.549E+13	1.619E+13	1.650E+13
8	7.598E+12	7.597E+12	7.624E+12	8.742E+12	1.205E+13	9.023E+12	8.967E+12	1.802E+13	9.730E+12	1.067E+13	1.355E+13
9	6.402E+12	6.363E+12	5.763E+12	7.324E+12	1.294E+13	7.594E+12	7.181E+12	1.818E+13	7.731E+12	8.904E+12	1.390E+13
10	2.815E+10	6.685E+10	5.504E+12	6.987E+12	2.122E+13	7.249E+12	6.868E+12	2.726E+13	7.392E+12	8.517E+12	2.197E+13
11	4.413E+12	6.098E+10	5.291E+12	6.695E+12	3.362E+13	6.947E+12	6.593E+12	4.067E+13	7.095E+12	8.169E+12	3.414E+13
12	4.418E+10	4.565E+10	4.175E+12	4.974E+12	4.305E+13	5.145E+12	5.014E+12	5.047E+13	5.384E+12	5.984E+12	4.655E+13
13	2.245E+13	2.254E+13	2.989E+13	3.237E+13	4.557E+13	3.339E+13	3.414E+13	5.173E+13	3.661E+13	3.800E+13	5.102E+13
14	2.462E+13	2.553E+13	3.993E+13	4.338E+13	4.595E+13	4.478E+13	4.594E+13	5.200E+13	4.901E+13	5.039E+13	5.158E+13
15	3.153E+13	3.233E+13	4.356E+13	4.700E+13	4.909E+13	4.849E+13	4.981E+13	5.506E+13	5.312E+13	5.453E+13	5.538E+13
16	6.501E+13	6.508E+13	6.602E+13	6.806E+13	6.901E+13	6.985E+13	7.220E+13	7.475E+13	7.668E+13	7.812E+13	7.824E+13
17	3.979E+13	3.980E+13	3.992E+13	4.089E+13	4.139E+13	4.192E+13	4.332E+13	4.466E+13	4.589E+13	4.669E+13	4.673E+13
18	2.056E+13	2.057E+13	2.062E+13	2.111E+13	2.137E+13	2.164E+13	2.239E+13	2.309E+13	2.375E+13	2.418E+13	2.421E+13
19	2.836E+12	2.836E+12	2.842E+12	2.950E+12	3.013E+12	3.072E+12	3.180E+12	3.264E+12	3.348E+12	3.404E+12	3.407E+12

PLANE NUMBER 7

1	3.320E+13	3.320E+13	3.318E+13	3.265E+13	3.237E+13	3.026E+13	2.671E+13	2.606E+13	2.560E+13	2.552E+13	2.552E+13
2	4.795E+13	4.794E+13	4.790E+13	4.384E+13	3.173E+13	2.775E+13	2.486E+13	2.484E+13	2.500E+13	2.520E+13	2.521E+13
3	2.743E+13	2.744E+13	2.761E+13	2.661E+13	2.584E+13	2.411E+13	2.342E+13	2.376E+13	2.435E+13	2.474E+13	2.476E+13
4	2.586E+13	2.593E+13	2.690E+13	2.562E+13	2.407E+13	2.294E+13	2.262E+13	2.272E+13	2.359E+13	2.404E+13	2.407E+13
5	2.353E+13	2.352E+13	2.294E+13	2.038E+13	1.994E+13	1.976E+13	2.216E+13	2.234E+13	2.377E+13	2.440E+13	2.444E+13
6	1.845E+13	1.845E+13	1.869E+13	1.580E+13	1.580E+13	1.584E+13	2.034E+13	2.161E+13	2.270E+13	2.358E+13	2.364E+13
7	1.462E+13	1.462E+13	1.493E+13	1.520E+13	1.568E+13	1.556E+13	1.659E+13	2.209E+13	1.816E+13	1.882E+13	1.915E+13
8	1.166E+13	1.165E+13	1.116E+13	1.235E+13	1.603E+13	1.274E+13	1.283E+13	2.299E+13	1.389E+13	1.493E+13	1.813E+13
9	1.020E+13	1.021E+13	1.029E+13	1.202E+13	1.832E+13	1.242E+13	1.213E+13	2.339E+13	1.305E+13	1.442E+13	2.003E+13
10	4.293E+10	1.161E+11	9.855E+12	1.151E+13	2.756E+13	1.190E+13	1.164E+13	3.377E+13	1.252E+13	1.383E+13	2.903E+13
11	5.306E+12	9.769E+10	9.405E+12	1.097E+13	4.130E+13	1.135E+13	1.111E+13	4.896E+13	1.195E+13	1.320E+13	4.245E+13
12	6.010E+10	6.335E+10	6.314E+12	7.186E+12	5.152E+13	7.416E+12	7.347E+12	5.979E+13	7.891E+12	8.577E+12	5.599E+13
13	3.041E+13	3.050E+13	3.672E+13	3.911E+13	5.436E+13	4.026E+13	4.136E+13	6.113E+13	4.432E+13	4.578E+13	6.098E+13
14	3.298E+13	3.392E+13	4.878E+13	5.201E+13	5.474E+13	5.356E+13	5.517E+13	6.141E+13	5.885E+13	6.024E+13	6.155E+13
15	4.038E+13	4.119E+13	5.253E+13	5.574E+13	5.785E+13	5.737E+13	5.914E+13	6.443E+13	6.306E+13	6.447E+13	6.531E+13
16	7.130E+13	7.136E+13	7.224E+13	7.416E+13	7.510E+13	7.600E+13	7.857E+13	8.122E+13	8.337E+13	8.482E+13	8.492E+13
17	4.237E+13	4.238E+13	4.250E+13	4.346E+13	4.397E+13	4.451E+13	4.600E+13	4.738E+13	4.868E+13	4.948E+13	4.952E+13
18	2.188E+13	2.188E+13	2.193E+13	2.242E+13	2.269E+13	2.298E+13	2.376E+13	2.450E+13	2.519E+13	2.562E+13	2.565E+13
19	2.940E+12	2.940E+12	2.947E+12	3.064E+12	3.137E+12	3.202E+12	3.314E+12	3.399E+12	3.487E+12	3.544E+12	3.548E+12

PLANE NUMBER 8

1	3.613E+13	3.613E+13	3.610E+13	3.551E+13	3.518E+13	3.277E+13	2.866E+13	2.787E+13	2.730E+13	2.719E+13	2.719E+13
2	5.199E+13	5.198E+13	5.192E+13	4.747E+13	3.445E+13	2.998E+13	2.664E+13	2.656E+13	2.666E+13	2.684E+13	2.686E+13
3	3.033E+13	3.034E+13	3.047E+13	2.927E+13	2.826E+13	2.610E+13	2.514E+13	2.551E+13	2.602E+13	2.638E+13	2.640E+13
4	2.882E+13	2.888E+13	2.969E+13	2.817E+13	2.637E+13	2.501E+13	2.444E+13	2.477E+13	2.533E+13	2.570E+13	2.572E+13
5	2.667E+13	2.666E+13	2.503E+13	2.236E+13	2.185E+13	2.160E+13	2.384E+13	2.465E+13	2.547E+13	2.605E+13	2.608E+13
6	2.261E+13	2.260E+13	2.039E+13	1.792E+13	1.791E+13	1.795E+13	2.203E+13	2.488E+13	2.450E+13	2.533E+13	2.538E+13
7	2.293E+13	2.290E+13	1.794E+13	1.797E+13	1.824E+13	1.838E+13	1.966E+13	2.791E+13	2.145E+13	2.208E+13	2.218E+13
8	2.543E+13	2.542E+13	2.316E+13	2.410E+13	2.531E+13	2.480E+13	2.538E+13	3.155E+13	2.740E+13	2.865E+13	2.921E+13
9	2.674E+13	2.684E+13	2.884E+13	3.031E+13	3.217E+13	3.122E+13	3.161E+13	3.322E+13	3.403E+13	3.578E+13	3.662E+13
10	3.673E+13	3.269E+13	2.972E+13	3.121E+13	4.274E+13	3.215E+13	3.256E+13	4.585E+13	3.506E+13	3.686E+13	4.757E+13
11	5.040E+13	3.946E+13	3.052E+13	3.203E+13	5.801E+13	3.299E+13	3.342E+13	6.377E+13	3.599E+13	3.784E+13	6.322E+13
12	5.930E+13	5.758E+13	4.635E+13	4.810E+13	6.811E+13	4.947E+13	5.077E+13	7.481E+13	5.465E+13	5.669E+13	7.664E+13
13	5.804E+13	5.809E+13	6.680E+13	6.878E+13	6.741E+13	7.064E+13	7.328E+13	7.335E+13	7.858E+13	8.029E+13	7.638E+13
14	5.858E+13	5.904E+13	6.629E+13	6.836E+13	6.773E+13	7.016E+13	7.286E+13	7.363E+13	7.776E+13	7.890E+13	7.680E+13
15	6.181E+13	6.223E+13	6.814E+13	7.021E+13	7.014E+13	7.204E+13	7.479E+13	7.614E+13	7.975E+13	8.091E+13	7.960E+13
16	7.678E+13	7.683E+13	7.745E+13	7.907E+13	7.990E+13	8.086E+13	8.360E+13	8.611E+13	8.858E+13	8.998E+13	9.002E+13
17	4.416E+13	4.417E+13	4.427E+13	4.518E+13	4.569E+13	4.624E+13	4.777E+13	4.916E+13	5.048E+13	5.126E+13	5.130E+13
18	2.274E+13	2.275E+13	2.279E+13	2.327E+13	2.355E+13	2.384E+13	2.465E+13	2.539E+13	2.608E+13	2.651E+13	2.654E+13
19	3.001E+12	3.001E+12	3.008E+12	3.136E+12	3.221E+12	3.292E+12	3.406E+12	3.490E+12	3.580E+12	3.639E+12	3.644E+12

Information Processing Center

Information Processing Center

Information Processing Center

Information Processing Center

PLANE NUMBER 9

	1	2	3	4	5	6	7	8	9	10	11
1	3.863E+13	3.862E+13	3.859E+13	3.788E+13	3.750E+13	3.454E+13	2.941E+13	2.833E+13	2.752E+13	2.733E+13	2.732E+13
2	5.484E+13	5.483E+13	5.474E+13	4.999E+13	3.658E+13	3.143E+13	2.726E+13	2.701E+13	2.693E+13	2.703E+13	2.704E+13
3	3.351E+13	3.351E+13	3.357E+13	3.209E+13	3.055E+13	2.755E+13	2.628E+13	2.628E+13	2.653E+13	2.676E+13	2.677E+13
4	3.213E+13	3.217E+13	3.270E+13	3.090E+13	2.873E+13	2.700E+13	2.579E+13	2.651E+13	2.632E+13	2.645E+13	2.645E+13
5	3.034E+13	3.032E+13	2.667E+13	2.440E+13	2.378E+13	2.338E+13	2.470E+13	2.694E+13	2.607E+13	2.643E+13	2.645E+13
6	2.776E+13	2.772E+13	2.130E+13	2.114E+13	2.114E+13	2.115E+13	2.274E+13	2.886E+13	2.498E+13	2.559E+13	2.564E+13
7	3.159E+13	3.152E+13	1.985E+13	1.982E+13	2.001E+13	2.023E+13	2.145E+13	3.482E+13	2.327E+13	2.374E+13	2.377E+13
8	3.603E+13	3.601E+13	3.133E+13	3.195E+13	3.235E+13	3.272E+13	3.357E+13	4.020E+13	3.611E+13	3.732E+13	3.709E+13
9	3.791E+13	3.810E+13	4.136E+13	4.236E+13	4.285E+13	4.340E+13	4.421E+13	4.248E+13	4.747E+13	4.921E+13	4.868E+13
10	4.878E+13	4.507E+13	4.251E+13	4.353E+13	5.365E+13	4.460E+13	4.543E+13	5.558E+13	4.878E+13	5.058E+13	5.991E+13
11	6.392E+13	5.267E+13	4.344E+13	4.447E+13	6.903E+13	4.557E+13	4.642E+13	7.390E+13	4.985E+13	5.170E+13	7.565E+13
12	7.430E+13	7.247E+13	5.953E+13	6.063E+13	7.873E+13	6.208E+13	6.383E+13	8.458E+13	6.850E+13	7.048E+13	8.839E+13
13	7.360E+13	7.362E+13	7.962E+13	8.054E+13	7.772E+13	8.234E+13	8.549E+13	8.291E+13	9.142E+13	9.292E+13	8.770E+13
14	7.395E+13	7.424E+13	7.878E+13	7.952E+13	7.803E+13	8.118E+13	8.444E+13	8.321E+13	8.991E+13	9.077E+13	8.809E+13
15	7.618E+13	7.644E+13	8.009E+13	8.087E+13	8.001E+13	8.253E+13	8.581E+13	8.537E+13	9.129E+13	9.216E+13	9.033E+13
16	8.144E+13	8.147E+13	8.187E+13	8.291E+13	8.351E+13	8.440E+13	8.716E+13	8.939E+13	9.208E+13	9.331E+13	9.330E+13
17	4.535E+13	4.536E+13	4.544E+13	4.626E+13	4.673E+13	4.727E+13	4.878E+13	5.014E+13	5.141E+13	5.212E+13	5.215E+13
18	2.323E+13	2.323E+13	2.326E+13	2.372E+13	2.401E+13	2.430E+13	2.510E+13	2.582E+13	2.648E+13	2.688E+13	2.690E+13
19	3.024E+12	3.024E+12	3.032E+12	3.177E+12	3.285E+12	3.365E+12	3.478E+12	3.557E+12	3.649E+12	3.711E+12	3.717E+12

Information Processing Center

Information Processing Center

PLANE NUMBER 10

	1	2	3	4	5	6	7	8	9	10	11
1	4.217E+13	4.217E+13	4.211E+13	4.106E+13	4.046E+13	3.468E+13	2.541E+13	2.346E+13	2.200E+13	2.162E+13	2.159E+13
2	5.667E+13	5.666E+13	5.655E+13	5.164E+13	3.900E+13	3.031E+13	2.343E+13	2.273E+13	2.228E+13	2.223E+13	2.223E+13
3	3.990E+13	3.991E+13	3.992E+13	3.797E+13	3.389E+13	2.740E+13	2.424E+13	2.424E+13	2.423E+13	2.427E+13	2.427E+13
4	3.843E+13	3.846E+13	3.889E+13	3.677E+13	3.407E+13	3.173E+13	2.941E+13	3.055E+13	2.936E+13	2.920E+13	2.919E+13
5	3.637E+13	3.632E+13	2.842E+13	2.751E+13	2.679E+13	2.612E+13	2.514E+13	3.155E+13	2.581E+13	2.566E+13	2.566E+13
6	3.357E+13	3.349E+13	2.037E+13	2.725E+13	2.728E+13	2.722E+13	2.129E+13	3.409E+13	2.259E+13	2.257E+13	2.259E+13
7	3.850E+13	3.838E+13	1.909E+13	1.963E+13	1.982E+13	1.992E+13	2.027E+13	4.112E+13	2.176E+13	2.186E+13	2.191E+13
8	4.326E+13	4.321E+13	3.341E+13	3.407E+13	3.476E+13	3.463E+13	3.518E+13	4.667E+13	3.760E+13	3.872E+13	3.891E+13
9	4.495E+13	4.495E+13	4.538E+13	4.634E+13	4.732E+13	4.710E+13	4.766E+13	4.866E+13	5.088E+13	5.263E+13	5.281E+13
10	5.279E+13	4.922E+13	4.644E+13	4.739E+13	5.537E+13	4.818E+13	4.878E+13	5.797E+13	5.207E+13	5.386E+13	6.115E+13
11	6.323E+13	5.445E+13	4.721E+13	4.815E+13	6.637E+13	4.896E+13	4.960E+13	7.032E+13	5.295E+13	5.476E+13	7.238E+13
12	7.006E+13	6.875E+13	6.063E+13	6.133E+13	7.295E+13	6.233E+13	6.385E+13	7.675E+13	6.814E+13	6.977E+13	8.104E+13
13	6.908E+13	6.913E+13	7.755E+13	7.748E+13	7.193E+13	7.856E+13	8.153E+13	7.475E+13	8.673E+13	8.747E+13	8.018E+13
14	6.959E+13	7.007E+13	7.763E+13	7.701E+13	7.248E+13	7.788E+13	8.117E+13	7.527E+13	8.600E+13	8.595E+13	8.082E+13
15	7.218E+13	7.262E+13	7.873E+13	7.816E+13	7.485E+13	7.900E+13	8.228E+13	7.789E+13	8.711E+13	8.710E+13	8.342E+13
16	7.814E+13	7.818E+13	7.863E+13	7.892E+13	7.892E+13	7.954E+13	8.194E+13	8.358E+13	8.614E+13	8.702E+13	8.691E+13
17	4.346E+13	4.347E+13	4.355E+13	4.429E+13	4.465E+13	4.519E+13	4.656E+13	4.786E+13	4.891E+13	4.949E+13	4.947E+13
18	2.208E+13	2.208E+13	2.211E+13	2.259E+13	2.297E+13	2.324E+13	2.395E+13	2.461E+13	2.517E+13	2.551E+13	2.553E+13
19	2.922E+12	2.923E+12	2.931E+12	3.092E+12	3.238E+12	3.321E+12	3.427E+12	3.494E+12	3.588E+12	3.651E+12	3.661E+12

Information Processing Center

Information Processing Center

PLANE NUMBER 11

	1	2	3	4	5	6	7	8	9	10	11
1	4.612E+13	4.612E+13	4.606E+13	4.508E+13	4.452E+13	3.907E+13	3.061E+13	2.887E+13	2.758E+13	2.724E+13	2.723E+13
2	6.064E+13	6.063E+13	6.054E+13	5.579E+13	4.333E+13	3.516E+13	2.890E+13	2.825E+13	2.790E+13	2.787E+13	2.787E+13
3	4.531E+13	4.531E+13	4.542E+13	4.366E+13	3.948E+13	3.328E+13	3.043E+13	3.035E+13	3.049E+13	3.061E+13	3.062E+13
4	4.442E+13	4.448E+13	4.533E+13	4.361E+13	4.211E+13	4.056E+13	3.878E+13	3.859E+13	3.895E+13	3.905E+13	3.906E+13
5	4.131E+13	4.127E+13	3.405E+13	3.291E+13	3.243E+13	3.199E+13	3.165E+13	3.748E+13	3.243E+13	3.241E+13	3.241E+13
6	3.767E+13	3.760E+13	2.633E+13	3.135E+13	3.136E+13	3.132E+13	2.713E+13	3.830E+13	2.871E+13	2.881E+13	2.883E+13
7	4.264E+13	4.253E+13	2.544E+13	2.494E+13	2.522E+13	2.515E+13	2.563E+13	4.520E+13	2.744E+13	2.768E+13	2.788E+13
8	4.944E+13	4.937E+13	3.715E+13	3.794E+13	4.060E+13	3.836E+13	3.873E+13	5.261E+13	4.127E+13	4.267E+13	4.505E+13
9	5.289E+13	5.265E+13	4.932E+13	5.053E+13	5.543E+13	5.108E+13	5.133E+13	5.624E+13	5.463E+13	5.677E+13	6.131E+13
10	5.570E+13	5.540E+13	5.026E+13	5.146E+13	5.789E+13	5.202E+13	5.230E+13	5.913E+13	5.567E+13	5.783E+13	6.402E+13
11	5.786E+13	5.781E+13	5.577E+13	5.675E+13	6.002E+13	5.738E+13	5.813E+13	6.137E+13	6.188E+13	6.384E+13	6.638E+13
12	6.019E+13	6.021E+13	6.865E+13	6.899E+13	6.238E+13	6.972E+13	7.160E+13	6.380E+13	7.618E+13	7.756E+13	6.901E+13
13	6.289E+13	6.299E+13	7.887E+13	7.822E+13	6.514E+13	7.886E+13	8.190E+13	6.663E+13	8.689E+13	8.723E+13	7.212E+13
14	6.474E+13	6.548E+13	7.729E+13	7.599E+13	6.714E+13	7.636E+13	7.964E+13	6.861E+13	8.417E+13	8.370E+13	7.438E+13
15	6.905E+13	6.965E+13	7.809E+13	7.688E+13	7.121E+13	7.722E+13	8.043E+13	7.307E+13	8.494E+13	8.457E+13	7.880E+13
16	7.623E+13	7.627E+13	7.673E+13	7.666E+13	7.629E+13	7.678E+13	7.899E+13	8.037E+13	8.283E+13	8.356E+13	8.339E+13
17	4.240E+13	4.241E+13	4.248E+13	4.320E+13	4.348E+13	4.405E+13	4.534E+13	4.666E+13	4.756E+13	4.808E+13	4.803E+13

Information Processing Center

Information Processing Center

18 2.145E+13 2.146E+13 2.149E+13 2.199E+13 2.255E+13 2.277E+13 2.343E+13 2.405E+13 2.457E+13 2.489E+13 2.494E+13
 19 2.867E+12 2.868E+12 2.875E+12 3.044E+12 3.210E+12 3.293E+12 3.394E+12 3.456E+12 3.551E+12 3.615E+12 3.626E+12

PLANE NUMBER 12

	1	2	3	4	5	6	7	8	9	10	11
1	6.986E+13	6.986E+13	6.986E+13	6.997E+13	7.069E+13	7.210E+13	7.247E+13	7.233E+13	7.218E+13	7.215E+13	7.214E+13
2	8.545E+13	8.544E+13	8.532E+13	8.123E+13	7.103E+13	7.041E+13	6.913E+13	6.917E+13	6.933E+13	6.949E+13	6.950E+13
3	6.432E+13	6.432E+13	6.436E+13	6.328E+13	6.510E+13	6.496E+13	6.407E+13	6.435E+13	6.483E+13	6.514E+13	6.516E+13
4	5.992E+13	5.994E+13	6.020E+13	5.896E+13	5.840E+13	5.780E+13	5.700E+13	5.702E+13	5.770E+13	5.800E+13	5.802E+13
5	6.078E+13	6.102E+13	6.437E+13	6.253E+13	6.212E+13	6.186E+13	6.280E+13	5.912E+13	6.470E+13	6.538E+13	6.542E+13
6	5.787E+13	5.819E+13	6.278E+13	5.235E+13	5.207E+13	5.232E+13	6.380E+13	5.984E+13	6.795E+13	6.909E+13	6.916E+13
7	5.744E+13	5.745E+13	5.773E+13	5.741E+13	5.761E+13	5.750E+13	5.923E+13	6.083E+13	6.350E+13	6.470E+13	6.498E+13
8	5.865E+13	5.851E+13	5.655E+13	5.732E+13	5.989E+13	5.766E+13	5.837E+13	6.211E+13	6.221E+13	6.417E+13	6.650E+13
9	5.860E+13	5.836E+13	5.490E+13	5.597E+13	5.983E+13	5.637E+13	5.672E+13	6.183E+13	6.032E+13	6.251E+13	6.604E+13
10	5.975E+13	5.951E+13	5.540E+13	5.645E+13	6.102E+13	5.685E+13	5.723E+13	6.292E+13	6.086E+13	6.303E+13	6.731E+13
11	6.093E+13	6.090E+13	6.025E+13	6.100E+13	6.231E+13	6.138E+13	6.219E+13	6.405E+13	6.610E+13	6.803E+13	6.869E+13
12	6.251E+13	6.253E+13	7.074E+13	6.078E+13	6.395E+13	7.111E+13	7.286E+13	6.554E+13	7.736E+13	7.869E+13	7.045E+13
13	6.455E+13	6.464E+13	7.842E+13	7.743E+13	6.601E+13	7.752E+13	8.020E+13	6.746E+13	8.487E+13	8.521E+13	7.265E+13
14	6.608E+13	6.672E+13	7.693E+13	7.533E+13	6.763E+13	7.517E+13	7.805E+13	6.897E+13	8.232E+13	8.195E+13	7.439E+13
15	6.976E+13	7.028E+13	7.762E+13	7.610E+13	7.099E+13	7.590E+13	8.072E+13	7.260E+13	8.296E+13	8.268E+13	7.795E+13
16	7.458E+13	7.461E+13	7.502E+13	7.466E+13	7.389E+13	7.426E+13	7.631E+13	7.755E+13	7.985E+13	8.047E+13	8.028E+13
17	4.144E+13	4.145E+13	4.152E+13	4.223E+13	4.243E+13	4.304E+13	4.241E+13	4.562E+13	4.638E+13	4.686E+13	4.676E+13
18	2.090E+13	2.091E+13	2.094E+13	2.148E+13	2.245E+13	2.255E+13	2.315E+13	2.371E+13	2.424E+13	2.455E+13	2.465E+13
19	2.818E+12	2.818E+12	2.826E+12	2.999E+12	3.183E+12	3.264E+12	3.362E+12	3.418E+12	3.515E+12	3.579E+12	3.593E+12

PLANE NUMBER 13

	1	2	3	4	5	6	7	8	9	10	11
1	8.577E+13	8.577E+13	8.577E+13	8.573E+13	8.589E+13	8.614E+13	8.638E+13	8.644E+13	8.649E+13	8.655E+13	8.655E+13
2	9.043E+13	9.042E+13	9.035E+13	8.819E+13	8.453E+13	8.321E+13	8.249E+13	8.276E+13	8.309E+13	8.333E+13	8.335E+13
3	7.731E+13	7.731E+13	7.731E+13	7.639E+13	7.665E+13	7.649E+13	7.606E+13	7.654E+13	7.715E+13	7.754E+13	7.756E+13
4	6.625E+13	6.626E+13	6.636E+13	6.527E+13	6.482E+13	6.437E+13	6.383E+13	6.409E+13	6.472E+13	6.506E+13	6.508E+13
5	7.490E+13	7.500E+13	7.639E+13	7.480E+13	7.443E+13	7.421E+13	7.512E+13	7.426E+13	7.742E+13	7.818E+13	7.822E+13
6	7.477E+13	7.493E+13	7.720E+13	7.060E+13	7.020E+13	7.030E+13	7.758E+13	7.686E+13	8.238E+13	8.371E+13	8.378E+13
7	7.144E+13	7.143E+13	7.133E+13	7.072E+13	7.062E+13	7.046E+13	7.234E+13	7.484E+13	7.762E+13	7.910E+13	7.912E+13
8	6.747E+13	6.734E+13	6.557E+13	6.595E+13	6.770E+13	6.602E+13	6.704E+13	7.086E+13	7.151E+13	7.346E+13	7.520E+13
9	6.003E+13	5.980E+13	5.652E+13	5.751E+13	6.102E+13	5.785E+13	5.825E+13	6.320E+13	6.194E+13	6.411E+13	6.732E+13
10	6.100E+13	6.079E+13	5.714E+13	5.807E+13	6.205E+13	5.839E+13	5.884E+13	6.407E+13	6.255E+13	6.468E+13	6.839E+13
11	6.205E+13	6.203E+13	6.335E+13	6.375E+13	6.320E+13	6.387E+13	6.481E+13	6.502E+13	6.881E+13	7.057E+13	6.960E+13
12	6.361E+13	6.363E+13	7.243E+13	7.203E+13	6.478E+13	7.195E+13	7.370E+13	6.640E+13	7.810E+13	7.922E+13	7.124E+13
13	6.628E+13	6.638E+13	7.757E+13	7.611E+13	6.730E+13	7.564E+13	7.804E+13	6.871E+13	8.235E+13	8.252E+13	7.380E+13
14	6.762E+13	6.816E+13	7.678E+13	7.505E+13	6.864E+13	7.460E+13	7.723E+13	6.996E+13	8.138E+13	8.112E+13	7.521E+13
15	7.072E+13	7.117E+13	7.748E+13	7.583E+13	7.136E+13	7.531E+13	7.789E+13	7.290E+13	8.201E+13	8.182E+13	7.800E+13
16	7.375E+13	7.378E+13	7.414E+13	7.365E+13	7.263E+13	7.296E+13	7.494E+13	7.610E+13	7.833E+13	7.889E+13	7.869E+13
17	4.095E+13	4.096E+13	4.102E+13	4.174E+13	4.184E+13	4.252E+13	4.371E+13	4.511E+13	4.578E+13	4.624E+13	4.611E+13
18	2.062E+13	2.063E+13	2.066E+13	2.123E+13	2.256E+13	2.253E+13	2.310E+13	2.360E+13	2.416E+13	2.448E+13	2.464E+13
19	2.792E+12	2.793E+12	2.801E+12	2.976E+12	3.170E+12	3.249E+12	3.345E+12	3.399E+12	3.497E+12	3.561E+12	3.576E+12

PLANE NUMBER 14

	1	2	3	4	5	6	7	8	9	10	11
1	9.000E+13	9.000E+13	8.999E+13	8.986E+13	8.982E+13	8.979E+13	8.981E+13	8.995E+13	9.009E+13	9.018E+13	9.018E+13
2	8.770E+13	8.769E+13	8.766E+13	8.693E+13	8.646E+13	8.611E+13	8.591E+13	8.626E+13	8.663E+13	8.688E+13	8.689E+13
3	8.134E+13	8.134E+13	8.131E+13	8.056E+13	8.033E+13	8.011E+13	7.994E+13	8.047E+13	8.106E+13	8.143E+13	8.146E+13
4	7.356E+13	7.356E+13	7.356E+13	7.261E+13	7.225E+13	7.193E+13	7.167E+13	7.215E+13	7.279E+13	7.317E+13	7.320E+13
5	8.064E+13	8.065E+13	8.083E+13	7.952E+13	7.915E+13	7.890E+13	7.938E+13	8.013E+13	8.161E+13	8.229E+13	8.232E+13
6	8.364E+13	8.367E+13	8.413E+13	8.074E+13	8.014E+13	7.993E+13	8.294E+13	8.444E+13	8.762E+13	8.889E+13	8.896E+13
7	7.973E+13	7.972E+13	7.953E+13	7.842E+13	7.783E+13	7.753E+13	7.924E+13	8.198E+13	8.502E+13	8.659E+13	8.671E+13
8	7.725E+13	7.722E+13	7.674E+13	7.614E+13	7.600E+13	7.546E+13	7.690E+13	7.965E+13	8.210E+13	8.376E+13	8.421E+13
9	7.751E+13	7.749E+13	7.726E+13	7.680E+13	7.664E+13	7.622E+13	7.769E+13	8.010E+13	8.272E+13	8.434E+13	8.473E+13
10	7.365E+13	7.372E+13	7.466E+13	7.398E+13	7.307E+13	7.334E+13	7.480E+13	7.577E+13	7.936E+13	8.066E+13	8.035E+13
11	7.283E+13	7.298E+13	7.516E+13	7.423E+13	7.235E+13	7.349E+13	7.507E+13	7.472E+13	7.949E+13	8.055E+13	7.935E+13
12	7.259E+13	7.289E+13	7.730E+13	7.588E+13	7.246E+13	7.505E+13	7.703E+13	7.440E+13	8.133E+13	8.183E+13	7.926E+13
13	6.993E+13	7.036E+13	7.659E+13	7.472E+13	7.025E+13	7.385E+13	7.609E+13	7.152E+13	8.009E+13	8.004E+13	7.656E+13
14	7.018E+13	7.061E+13	7.664E+13	7.477E+13	7.046E+13	7.393E+13	7.622E+13	7.173E+13	8.022E+13	8.012E+13	7.676E+13

15	7.231E+13	7.265E+13	7.739E+13	7.557E+13	7.205E+13	7.460E+13	7.682E+13	7.350E+13	8.078E+13	8.075E+13	7.824E+13
16	7.263E+13	7.265E+13	7.296E+13	7.229E+13	7.090E+13	7.119E+13	7.306E+13	7.414E+13	7.625E+13	7.675E+13	7.651E+13
17	4.028E+13	4.029E+13	4.035E+13	4.108E+13	4.107E+13	4.182E+13	4.297E+13	4.442E+13	4.497E+13	4.541E+13	4.522E+13
18	2.025E+13	2.025E+13	2.028E+13	2.090E+13	2.285E+13	2.259E+13	2.311E+13	2.353E+13	2.414E+13	2.447E+13	2.473E+13
19	2.758E+12	2.759E+12	2.767E+12	2.944E+12	3.151E+12	3.229E+12	3.323E+12	3.372E+12	3.472E+12	3.536E+12	3.552E+12

PLANE NUMBER 15

	1	2	3	4	5	6	7	8	9	10	11
1	8.386E+13	8.386E+13	8.383E+13	8.367E+13	8.361E+13	8.356E+13	8.350E+13	8.360E+13	8.367E+13	8.374E+13	8.374E+13
2	8.281E+13	8.281E+13	8.274E+13	8.228E+13	8.210E+13	8.195E+13	8.182E+13	8.215E+13	8.242E+13	8.262E+13	8.263E+13
3	8.152E+13	8.151E+13	8.147E+13	8.071E+13	8.042E+13	8.018E+13	8.000E+13	8.052E+13	8.107E+13	8.141E+13	8.143E+13
4	8.069E+13	8.068E+13	8.063E+13	7.964E+13	7.926E+13	7.895E+13	7.879E+13	7.947E+13	8.021E+13	8.064E+13	8.067E+13
5	8.149E+13	8.148E+13	8.142E+13	8.007E+13	7.956E+13	7.915E+13	7.908E+13	8.002E+13	8.107E+13	8.164E+13	8.167E+13
6	8.319E+13	8.318E+13	8.310E+13	8.057E+13	7.958E+13	7.890E+13	7.934E+13	8.109E+13	8.322E+13	8.422E+13	8.425E+13
7	8.394E+13	8.393E+13	8.381E+13	8.137E+13	7.929E+13	7.846E+13	7.933E+13	8.158E+13	8.544E+13	8.684E+13	8.680E+13
8	8.082E+13	8.083E+13	8.101E+13	7.875E+13	7.662E+13	7.610E+13	7.705E+13	7.846E+13	8.208E+13	8.325E+13	8.318E+13
9	7.973E+13	7.976E+13	8.026E+13	7.794E+13	7.566E+13	7.532E+13	7.629E+13	7.714E+13	8.083E+13	8.181E+13	8.164E+13
10	7.901E+13	7.907E+13	7.999E+13	7.758E+13	7.510E+13	7.497E+13	7.599E+13	7.629E+13	8.019E+13	8.098E+13	8.063E+13
11	7.874E+13	7.882E+13	7.998E+13	7.750E+13	7.490E+13	7.489E+13	7.593E+13	7.593E+13	7.997E+13	8.066E+13	8.020E+13
12	7.836E+13	7.846E+13	7.986E+13	7.737E+13	7.466E+13	7.478E+13	7.588E+13	7.561E+13	7.983E+13	8.042E+13	7.984E+13
13	7.756E+13	7.769E+13	7.948E+13	7.702E+13	7.416E+13	7.454E+13	7.575E+13	7.509E+13	7.959E+13	8.007E+13	7.928E+13
14	7.706E+13	7.720E+13	7.908E+13	7.669E+13	7.380E+13	7.425E+13	7.552E+13	7.476E+13	7.927E+13	7.968E+13	7.884E+13
15	7.660E+13	7.672E+13	7.847E+13	7.618E+13	7.336E+13	7.375E+13	7.507E+13	7.442E+13	7.868E+13	7.905E+13	7.827E+13
16	7.017E+13	7.018E+13	7.035E+13	6.933E+13	6.674E+13	6.717E+13	6.884E+13	6.965E+13	7.160E+13	7.195E+13	7.157E+13
17	3.880E+13	3.881E+13	3.887E+13	3.963E+13	3.926E+13	4.026E+13	4.130E+13	4.296E+13	4.319E+13	4.358E+13	4.321E+13
18	1.942E+13	1.943E+13	1.946E+13	2.022E+13	2.493E+13	2.358E+13	2.395E+13	2.398E+13	2.494E+13	2.532E+13	2.606E+13
19	2.681E+12	2.682E+12	2.690E+12	2.872E+12	3.109E+12	3.180E+12	3.269E+12	3.310E+12	3.412E+12	3.477E+12	3.498E+12

PLANE NUMBER 16

	1	2	3	4	5	6	7	8	9	10	11
1	8.896E+13	8.898E+13	9.065E+13	9.058E+13	9.047E+13	9.035E+13	8.998E+13	8.829E+13	9.017E+13	9.046E+13	9.047E+13
2	8.775E+13	8.778E+13	9.003E+13	8.933E+13	8.899E+13	8.869E+13	8.826E+13	8.641E+13	8.908E+13	8.944E+13	8.945E+13
3	8.920E+13	8.920E+13	8.922E+13	8.787E+13	8.725E+13	8.672E+13	8.625E+13	8.688E+13	8.779E+13	8.823E+13	8.825E+13
4	8.801E+13	8.801E+13	8.793E+13	8.614E+13	8.515E+13	8.446E+13	8.398E+13	8.493E+13	8.617E+13	8.672E+13	8.671E+13
5	8.888E+13	8.887E+13	8.876E+13	8.630E+13	8.480E+13	8.390E+13	8.334E+13	8.458E+13	8.640E+13	8.710E+13	8.704E+13
6	8.894E+13	8.893E+13	8.876E+13	8.495E+13	8.222E+13	8.101E+13	8.077E+13	8.263E+13	8.589E+13	8.697E+13	8.674E+13
7	8.846E+13	8.845E+13	8.825E+13	8.357E+13	7.744E+13	7.665E+13	7.657E+13	7.765E+13	8.400E+13	8.530E+13	8.472E+13
8	8.423E+13	8.423E+13	8.426E+13	8.027E+13	7.526E+13	7.501E+13	7.507E+13	7.537E+13	8.007E+13	8.111E+13	8.081E+13
9	8.165E+13	8.166E+13	8.189E+13	7.801E+13	7.355E+13	7.342E+13	7.349E+13	7.332E+13	7.736E+13	7.822E+13	7.807E+13
10	8.120E+13	8.123E+13	8.159E+13	7.788E+13	7.340E+13	7.336E+13	7.352E+13	7.325E+13	7.731E+13	7.811E+13	7.791E+13
11	8.057E+13	8.060E+13	8.115E+13	7.766E+13	7.326E+13	7.331E+13	7.360E+13	7.323E+13	7.733E+13	7.808E+13	7.780E+13
12	7.990E+13	7.995E+13	8.066E+13	7.735E+13	7.298E+13	7.310E+13	7.349E+13	7.303E+13	7.714E+13	7.782E+13	7.746E+13
13	7.908E+13	7.914E+13	8.003E+13	7.690E+13	7.256E+13	7.274E+13	7.323E+13	7.270E+13	7.677E+13	7.736E+13	7.691E+13
14	7.832E+13	7.839E+13	7.935E+13	7.638E+13	7.214E+13	7.232E+13	7.288E+13	7.236E+13	7.628E+13	7.682E+13	7.631E+13
15	7.727E+13	7.734E+13	7.830E+13	7.554E+13	7.149E+13	7.161E+13	7.227E+13	7.188E+13	7.548E+13	7.595E+13	7.539E+13
16	6.806E+13	6.807E+13	6.818E+13	6.698E+13	6.244E+13	6.365E+13	6.517E+13	6.560E+13	6.759E+13	6.783E+13	6.707E+13
17	3.757E+13	3.758E+13	3.763E+13	3.846E+13	3.743E+13	3.892E+13	3.984E+13	4.184E+13	4.166E+13	4.205E+13	4.136E+13
18	1.875E+13	1.876E+13	1.879E+13	1.973E+13	3.160E+13	2.714E+13	2.729E+13	2.631E+13	2.833E+13	2.884E+13	3.091E+13
19	2.616E+12	2.616E+12	2.624E+12	2.809E+12	3.070E+12	3.133E+12	3.218E+12	3.252E+12	3.357E+12	3.422E+12	3.446E+12

PLANE NUMBER 17

	1	2	3	4	5	6	7	8	9	10	11
1	9.268E+13	9.268E+13	9.267E+13	9.219E+13	9.197E+13	9.175E+13	9.135E+13	9.135E+13	9.142E+13	9.150E+13	9.150E+13
2	9.254E+13	9.254E+13	9.254E+13	9.122E+13	9.061E+13	9.005E+13	8.930E+13	8.965E+13	9.019E+13	9.049E+13	9.050E+13
3	9.245E+13	9.244E+13	9.233E+13	9.007E+13	8.893E+13	8.797E+13	8.694E+13	8.777E+13	8.881E+13	8.931E+13	8.932E+13
4	9.224E+13	9.223E+13	9.207E+13	8.890E+13	8.677E+13	8.545E+13	8.431E+13	8.550E+13	8.735E+13	8.800E+13	8.791E+13
5	9.204E+13	9.202E+13	9.183E+13	8.776E+13	8.493E+13	8.363E+13	8.246E+13	8.380E+13	8.610E+13	8.688E+13	8.679E+13
6	9.108E+13	9.106E+13	9.079E+13	8.504E+13	8.065E+13	7.902E+13	7.801E+13	7.973E+13	8.349E+13	8.457E+13	8.440E+13
7	8.797E+13	8.795E+13	8.770E+13	8.148E+13	7.497E+13	7.434E+13	7.388E+13	7.444E+13	7.996E+13	8.112E+13	8.082E+13
8	8.478E+13	8.477E+13	8.466E+13	7.941E+13	7.375E+13	7.362E+13	7.332E+13	7.333E+13	7.737E+13	7.831E+13	7.823E+13
9	8.347E+13	8.346E+13	8.342E+13	7.858E+13	7.325E+13	7.319E+13	7.300E+13	7.291E+13	7.644E+13	7.731E+13	7.728E+13
10	8.258E+13	8.258E+13	8.259E+13	7.802E+13	7.289E+13	7.277E+13	7.267E+13	7.261E+13	7.593E+13	7.673E+13	7.667E+13
11	8.190E+13	8.190E+13	8.195E+13	7.759E+13	7.260E+13	7.245E+13	7.242E+13	7.238E+13	7.553E+13	7.630E+13	7.620E+13

Information Processing Center

Information Processing Center

Information Processing Center

Information Processing Center

12	8.111E+13	8.111E+13	8.121E+13	7.708E+13	7.226E+13	7.207E+13	7.211E+13	7.212E+13	7.508E+13	7.579E+13	7.566E+13
13	8.012E+13	8.013E+13	8.027E+13	7.641E+13	7.184E+13	7.160E+13	7.172E+13	7.179E+13	7.451E+13	7.516E+13	7.498E+13
14	7.910E+13	7.912E+13	7.929E+13	7.569E+13	7.142E+13	7.110E+13	7.130E+13	7.147E+13	7.390E+13	7.449E+13	7.426E+13
15	7.758E+13	7.760E+13	7.780E+13	7.454E+13	7.081E+13	7.036E+13	7.065E+13	7.102E+13	7.296E+13	7.348E+13	7.317E+13
16	6.538E+13	6.539E+13	6.543E+13	6.405E+13	5.995E+13	6.084E+13	6.223E+13	6.336E+13	6.439E+13	6.455E+13	6.394E+13
17	3.601E+13	3.602E+13	3.607E+13	3.700E+13	3.685E+13	3.773E+13	3.855E+13	4.044E+13	4.026E+13	4.064E+13	4.031E+13
18	1.791E+13	1.791E+13	1.794E+13	1.911E+13	3.343E+13	2.901E+13	2.906E+13	2.796E+13	3.017E+13	3.075E+13	3.278E+13
19	2.532E+12	2.533E+12	2.541E+12	2.728E+12	3.018E+12	3.078E+12	3.159E+12	3.177E+12	3.293E+12	3.358E+12	3.386E+12

PLANE NUMBER 18

	1	2	3	4	5	6	7	8	9	10	11	
Information Processing Center	1	8.990E+13	8.990E+13	8.988E+13	8.942E+13	8.921E+13	8.901E+13	8.863E+13	8.862E+13	8.863E+13	8.867E+13	8.867E+13
	2	8.988E+13	8.987E+13	8.981E+13	8.862E+13	8.808E+13	8.758E+13	8.688E+13	8.717E+13	8.754E+13	8.777E+13	8.778E+13
	3	8.975E+13	8.974E+13	8.964E+13	8.765E+13	8.666E+13	8.581E+13	8.485E+13	8.550E+13	8.632E+13	8.672E+13	8.673E+13
	4	8.952E+13	8.951E+13	8.937E+13	8.661E+13	8.479E+13	8.365E+13	8.258E+13	8.352E+13	8.500E+13	8.555E+13	8.547E+13
	5	8.922E+13	8.921E+13	8.903E+13	8.553E+13	8.319E+13	8.208E+13	8.097E+13	8.203E+13	8.386E+13	8.452E+13	8.447E+13
	6	8.783E+13	8.781E+13	8.757E+13	8.268E+13	7.916E+13	7.781E+13	7.680E+13	7.816E+13	8.105E+13	8.199E+13	8.192E+13
	7	8.410E+13	8.408E+13	8.386E+13	7.880E+13	7.420E+13	7.371E+13	7.324E+13	7.366E+13	7.728E+13	7.824E+13	7.812E+13
	8	8.120E+13	8.119E+13	8.102E+13	7.676E+13	7.294E+13	7.289E+13	7.255E+13	7.253E+13	7.484E+13	7.563E+13	7.568E+13
	9	8.001E+13	8.000E+13	7.987E+13	7.593E+13	7.241E+13	7.234E+13	7.207E+13	7.208E+13	7.395E+13	7.467E+13	7.475E+13
	10	7.914E+13	7.913E+13	7.901E+13	7.530E+13	7.201E+13	7.178E+13	7.157E+13	7.175E+13	7.338E+13	7.406E+13	7.409E+13
	11	7.845E+13	7.844E+13	7.833E+13	7.480E+13	7.169E+13	7.136E+13	7.119E+13	7.149E+13	7.294E+13	7.358E+13	7.359E+13
	12	7.762E+13	7.761E+13	7.752E+13	7.419E+13	7.132E+13	7.088E+13	7.076E+13	7.120E+13	7.241E+13	7.301E+13	7.299E+13
	13	7.656E+13	7.656E+13	7.648E+13	7.340E+13	7.084E+13	7.027E+13	7.021E+13	7.083E+13	7.175E+13	7.229E+13	7.224E+13
	14	7.545E+13	7.544E+13	7.538E+13	7.253E+13	7.037E+13	6.966E+13	6.966E+13	7.046E+13	7.104E+13	7.154E+13	7.145E+13
	15	7.375E+13	7.375E+13	7.371E+13	7.116E+13	6.969E+13	6.876E+13	6.884E+13	6.994E+13	6.998E+13	7.041E+13	7.025E+13
	16	6.005E+13	6.005E+13	6.005E+13	5.912E+13	5.716E+13	5.749E+13	5.870E+13	6.062E+13	6.051E+13	6.062E+13	6.031E+13
	17	3.303E+13	3.303E+13	3.309E+13	3.429E+13	3.623E+13	3.587E+13	3.648E+13	3.767E+13	3.798E+13	3.841E+13	3.875E+13
	18	1.634E+13	1.634E+13	1.638E+13	1.768E+13	3.326E+13	2.842E+13	2.836E+13	2.247E+13	2.939E+13	3.002E+13	3.230E+13
	19	2.367E+12	2.367E+12	2.375E+12	2.559E+12	2.858E+12	2.930E+12	3.004E+12	2.984E+12	3.130E+12	3.193E+12	3.222E+12

PLANE NUMBER 19

	1	2	3	4	5	6	7	8	9	10	11	
Information Processing Center	1	8.385E+13	8.385E+13	8.384E+13	8.359E+13	8.347E+13	8.336E+13	8.314E+13	8.312E+13	8.311E+13	8.313E+13	8.313E+13
	2	8.374E+13	8.374E+13	8.371E+13	8.309E+13	8.283E+13	8.258E+13	8.219E+13	8.232E+13	8.248E+13	8.261E+13	8.261E+13
	3	8.354E+13	8.354E+13	8.349E+13	8.249E+13	8.208E+13	8.169E+13	8.116E+13	8.145E+13	8.180E+13	8.204E+13	8.206E+13
	4	8.325E+13	8.324E+13	8.317E+13	8.185E+13	8.130E+13	8.080E+13	8.019E+13	8.063E+13	8.116E+13	8.150E+13	8.152E+13
	5	8.287E+13	8.287E+13	8.278E+13	8.111E+13	8.044E+13	7.984E+13	7.915E+13	7.976E+13	8.047E+13	8.091E+13	8.094E+13
	6	8.124E+13	8.123E+13	8.109E+13	7.849E+13	7.740E+13	7.652E+13	7.576E+13	7.676E+13	7.803E+13	7.872E+13	7.878E+13
	7	7.745E+13	7.744E+13	7.730E+13	7.454E+13	7.336E+13	7.267E+13	7.227E+13	7.300E+13	7.433E+13	7.504E+13	7.511E+13
	8	7.471E+13	7.470E+13	7.458E+13	7.216E+13	7.132E+13	7.080E+13	7.059E+13	7.121E+13	7.210E+13	7.271E+13	7.278E+13
	9	7.359E+13	7.358E+13	7.347E+13	7.123E+13	7.050E+13	7.000E+13	6.987E+13	7.050E+13	7.123E+13	7.180E+13	7.186E+13
	10	7.275E+13	7.275E+13	7.265E+13	7.052E+13	6.990E+13	6.940E+13	6.932E+13	6.999E+13	7.060E+13	7.114E+13	7.119E+13
	11	7.209E+13	7.209E+13	7.199E+13	6.996E+13	6.942E+13	6.893E+13	6.888E+13	6.958E+13	7.010E+13	7.061E+13	7.066E+13
	12	7.130E+13	7.129E+13	7.121E+13	6.928E+13	6.884E+13	6.834E+13	6.835E+13	6.910E+13	6.951E+13	6.999E+13	7.003E+13
	13	7.028E+13	7.028E+13	7.020E+13	6.840E+13	6.808E+13	6.759E+13	6.765E+13	6.847E+13	6.875E+13	6.920E+13	6.923E+13
	14	6.920E+13	6.920E+13	6.913E+13	6.745E+13	6.727E+13	6.676E+13	6.689E+13	6.779E+13	6.794E+13	6.836E+13	6.839E+13
	15	6.756E+13	6.756E+13	6.750E+13	6.600E+13	6.597E+13	6.547E+13	6.570E+13	6.672E+13	6.672E+13	6.709E+13	6.711E+13
	16	5.424E+13	5.424E+13	5.424E+13	5.386E+13	5.393E+13	5.392E+13	5.501E+13	5.673E+13	5.655E+13	5.667E+13	5.667E+13
	17	2.987E+13	2.987E+13	2.992E+13	3.117E+13	3.381E+13	3.326E+13	3.375E+13	3.413E+13	3.502E+13	3.545E+13	3.602E+13
	18	1.472E+13	1.472E+13	1.476E+13	1.582E+13	2.281E+13	2.070E+13	2.078E+13	1.831E+13	2.148E+13	2.191E+13	2.313E+13
	19	2.184E+12	2.184E+12	2.192E+12	2.365E+12	2.629E+12	2.713E+12	2.782E+12	2.754E+12	2.896E+12	2.955E+12	2.979E+12

PLANE NUMBER 20

	1	2	3	4	5	6	7	8	9	10	11	
Information Processing Center	1	3.114E+13	3.114E+13	3.115E+13	3.117E+13	3.118E+13	3.119E+13	3.122E+13	3.124E+13	3.127E+13	3.128E+13	3.128E+13
	2	3.098E+13	3.098E+13	3.098E+13	3.101E+13	3.103E+13	3.104E+13	3.109E+13	3.113E+13	3.117E+13	3.119E+13	3.119E+13
	3	3.079E+13	3.079E+13	3.079E+13	3.083E+13	3.085E+13	3.088E+13	3.095E+13	3.100E+13	3.105E+13	3.108E+13	3.108E+13
	4	3.059E+13	3.059E+13	3.060E+13	3.064E+13	3.067E+13	3.070E+13	3.078E+13	3.085E+13	3.091E+13	3.094E+13	3.094E+13
	5	3.037E+13	3.037E+13	3.037E+13	3.042E+13	3.045E+13	3.049E+13	3.059E+13	3.066E+13	3.074E+13	3.078E+13	3.078E+13
	6	2.951E+13	2.951E+13	2.951E+13	2.959E+13	2.963E+13	2.969E+13	2.983E+13	2.995E+13	3.005E+13	3.011E+13	3.011E+13
	7	2.794E+13	2.794E+13	2.795E+13	2.807E+13	2.814E+13	2.822E+13	2.843E+13	2.857E+13	2.870E+13	2.877E+13	2.877E+13
	8	2.692E+13	2.692E+13	2.693E+13	2.708E+13	2.717E+13	2.726E+13	2.750E+13	2.765E+13	2.779E+13	2.785E+13	2.786E+13

Information Processing Center

Information Processing Center

9	2.651E+13	2.651E+13	2.652E+13	2.668E+13	2.677E+13	2.687E+13	2.713E+13	2.728E+13	2.742E+13	2.748E+13	2.749E+13
10	2.620E+13	2.621E+13	2.621E+13	2.638E+13	2.648E+13	2.659E+13	2.685E+13	2.700E+13	2.714E+13	2.721E+13	2.721E+13
11	2.597E+13	2.597E+13	2.598E+13	2.615E+13	2.625E+13	2.636E+13	2.663E+13	2.679E+13	2.693E+13	2.699E+13	2.700E+13
12	2.568E+13	2.568E+13	2.569E+13	2.587E+13	2.598E+13	2.610E+13	2.637E+13	2.653E+13	2.667E+13	2.674E+13	2.674E+13
13	2.532E+13	2.532E+13	2.533E+13	2.552E+13	2.563E+13	2.575E+13	2.603E+13	2.620E+13	2.633E+13	2.640E+13	2.641E+13
14	2.494E+13	2.494E+13	2.495E+13	2.515E+13	2.527E+13	2.539E+13	2.568E+13	2.584E+13	2.598E+13	2.605E+13	2.606E+13
15	2.436E+13	2.436E+13	2.437E+13	2.458E+13	2.471E+13	2.484E+13	2.514E+13	2.531E+13	2.545E+13	2.552E+13	2.552E+13
16	1.968E+13	1.968E+13	1.970E+13	2.001E+13	2.018E+13	2.035E+13	2.073E+13	2.094E+13	2.108E+13	2.115E+13	2.116E+13
17	1.132E+13	1.132E+13	1.134E+13	1.170E+13	1.194E+13	1.209E+13	1.235E+13	1.248E+13	1.263E+13	1.271E+13	1.273E+13
18	5.460E+12	5.461E+12	5.471E+12	5.674E+12	5.840E+12	5.919E+12	6.050E+12	6.096E+12	6.183E+12	6.230E+12	6.244E+12
19	1.070E+12	1.070E+12	1.074E+12	1.150E+12	1.207E+12	1.250E+12	1.292E+12	1.305E+12	1.337E+12	1.358E+12	1.360E+12

Information Processing Center

Information Processing Center

Information Processing Center

Information Processing Center

HOLY SAMPLE HOLDER, HF FIXED AT 12", B-SS BLADES AT 8", 24 ELEMENTS

POINT POWER DISTRIBUTION (WATTS/CC)

PLANE NUMBER 1

Information Processing Center	1	2	3	4	5	6	7	8	9	10	11
1	0.0	0.0	0.0	0.0	0.0	0.0	0.0	0.0	0.0	0.0	0.0
2	0.0	0.0	0.0	0.0	0.0	0.0	0.0	0.0	0.0	0.0	0.0
3	0.0	0.0	0.0	0.0	0.0	0.0	0.0	0.0	0.0	0.0	0.0
4	0.0	0.0	0.0	0.0	0.0	0.0	0.0	0.0	0.0	0.0	0.0
5	0.0	0.0	0.0	0.0	0.0	0.0	0.0	0.0	0.0	0.0	0.0
6	0.0	0.0	0.0	0.0	0.0	0.0	0.0	0.0	0.0	0.0	0.0
7	0.0	0.0	0.0	0.0	0.0	0.0	0.0	0.0	0.0	0.0	0.0
8	0.0	0.0	0.0	0.0	0.0	0.0	0.0	0.0	0.0	0.0	0.0
9	0.0	0.0	0.0	0.0	0.0	0.0	0.0	0.0	0.0	0.0	0.0
10	0.0	0.0	0.0	0.0	0.0	0.0	0.0	0.0	0.0	0.0	0.0
11	0.0	0.0	0.0	0.0	0.0	0.0	0.0	0.0	0.0	0.0	0.0
12	0.0	0.0	0.0	0.0	0.0	0.0	0.0	0.0	0.0	0.0	0.0
13	0.0	0.0	0.0	0.0	0.0	0.0	0.0	0.0	0.0	0.0	0.0
14	0.0	0.0	0.0	0.0	0.0	0.0	0.0	0.0	0.0	0.0	0.0
15	0.0	0.0	0.0	0.0	0.0	0.0	0.0	0.0	0.0	0.0	0.0
16	0.0	0.0	0.0	0.0	0.0	0.0	0.0	0.0	0.0	0.0	0.0
17	0.0	0.0	0.0	0.0	0.0	0.0	0.0	0.0	0.0	0.0	0.0
18	0.0	0.0	0.0	0.0	0.0	0.0	0.0	0.0	0.0	0.0	0.0
19	0.0	0.0	0.0	0.0	0.0	0.0	0.0	0.0	0.0	0.0	0.0

PLANE NUMBER 2

Information Processing Center	1	2	3	4	5	6	7	8	9	10	11
1	0.0	0.0	0.0	0.0	0.0	0.0	0.0	0.0	0.0	0.0	0.0
2	0.0	0.0	0.0	0.0	0.0	0.0	0.0	0.0	0.0	0.0	0.0
3	0.0	0.0	0.0	0.0	0.0	0.0	0.0	0.0	0.0	0.0	0.0
4	0.0	0.0	0.0	0.0	0.0	0.0	0.0	0.0	0.0	0.0	0.0
5	0.0	0.0	0.0	0.0	0.0	0.0	0.0	0.0	0.0	0.0	0.0
6	0.0	0.0	0.0	0.0	0.0	0.0	0.0	0.0	0.0	0.0	0.0
7	0.0	0.0	0.0	0.0	0.0	0.0	0.0	0.0	0.0	0.0	0.0
8	0.0	0.0	0.0	0.0	0.0	0.0	0.0	0.0	0.0	0.0	0.0
9	0.0	0.0	0.0	0.0	0.0	0.0	0.0	0.0	0.0	0.0	0.0
10	0.0	0.0	0.0	0.0	0.0	0.0	0.0	0.0	0.0	0.0	0.0
11	0.0	0.0	0.0	0.0	0.0	0.0	0.0	0.0	0.0	0.0	0.0
12	0.0	0.0	0.0	0.0	0.0	0.0	0.0	0.0	0.0	0.0	0.0
13	0.0	0.0	0.0	0.0	0.0	0.0	0.0	0.0	0.0	0.0	0.0
14	0.0	0.0	0.0	0.0	0.0	0.0	0.0	0.0	0.0	0.0	0.0
15	0.0	0.0	0.0	0.0	0.0	0.0	0.0	0.0	0.0	0.0	0.0
16	0.0	0.0	0.0	0.0	0.0	0.0	0.0	0.0	0.0	0.0	0.0
17	0.0	0.0	0.0	0.0	0.0	0.0	0.0	0.0	0.0	0.0	0.0
18	0.0	0.0	0.0	0.0	0.0	0.0	0.0	0.0	0.0	0.0	0.0
19	0.0	0.0	0.0	0.0	0.0	0.0	0.0	0.0	0.0	0.0	0.0

PLANE NUMBER 3

Information Processing Center	1	2	3	4	5	6	7	8	9	10	11
1	0.0	0.0	0.0	0.0	0.0	3.911E+01	3.505E+01	3.424E+01	3.365E+01	3.356E+01	3.355E+01
2	0.0	0.0	0.0	0.0	0.0	3.383E+01	3.014E+01	3.012E+01	3.001E+01	3.038E+01	3.044E+01
3	0.0	0.0	0.0	0.0	2.581E+01	2.507E+01	2.411E+01	2.532E+01	2.480E+01	2.567E+01	2.616E+01
4	0.0	0.0	0.0	0.0	0.0	0.0	0.0	0.0	0.0	0.0	0.0
5	0.0	0.0	2.470E+01	2.622E+01	2.644E+01	2.559E+01	2.410E+01	0.0	2.560E+01	2.755E+01	2.823E+01
6	0.0	0.0	2.800E+01	0.0	0.0	0.0	2.973E+01	0.0	3.252E+01	3.607E+01	3.628E+01
7	0.0	0.0	2.307E+01	2.570E+01	2.658E+01	2.618E+01	2.498E+01	0.0	2.716E+01	3.023E+01	3.086E+01

8	0.0	0.0	1.539E+01	1.853E+01	2.443E+01	1.902E+01	1.743E+01	0.0	1.888E+01	2.193E+01	2.689E+01
9	0.0	0.0	0.0	0.0	0.0	0.0	0.0	0.0	0.0	0.0	0.0
10	0.0	0.0	0.0	0.0	0.0	0.0	0.0	0.0	0.0	0.0	0.0
11	0.0	0.0	0.0	0.0	0.0	0.0	0.0	0.0	0.0	0.0	0.0
12	0.0	0.0	0.0	0.0	0.0	0.0	0.0	0.0	0.0	0.0	0.0
13	0.0	0.0	0.0	0.0	0.0	0.0	0.0	0.0	0.0	0.0	0.0
14	0.0	0.0	0.0	0.0	0.0	0.0	0.0	0.0	0.0	0.0	0.0
15	0.0	0.0	0.0	0.0	0.0	0.0	0.0	0.0	0.0	0.0	0.0
16	0.0	0.0	0.0	0.0	0.0	0.0	0.0	0.0	0.0	0.0	0.0
17	0.0	0.0	0.0	0.0	0.0	0.0	0.0	0.0	0.0	0.0	0.0
18	0.0	0.0	0.0	0.0	0.0	0.0	0.0	0.0	0.0	0.0	0.0
19	0.0	0.0	0.0	0.0	0.0	0.0	0.0	0.0	0.0	0.0	0.0

PLANE NUMBER 4

1	0.0	0.0	0.0	0.0	0.0	6.161E+01	5.662E+01	5.585E+01	5.536E+01	5.539E+01	5.540E+01
2	0.0	0.0	0.0	0.0	0.0	5.370E+01	4.902E+01	4.938E+01	4.957E+01	5.033E+01	5.044E+01
3	0.0	0.0	0.0	0.0	4.041E+01	3.988E+01	3.932E+01	4.143E+01	4.103E+01	4.258E+01	4.338E+01
4	0.0	0.0	0.0	0.0	0.0	0.0	0.0	0.0	0.0	0.0	0.0
5	0.0	0.0	3.943E+01	3.991E+01	4.020E+01	3.906E+01	3.924E+01	0.0	4.245E+01	4.589E+01	4.697E+01
6	0.0	0.0	4.518E+01	0.0	0.0	0.0	4.847E+01	0.0	5.422E+01	6.032E+01	6.067E+01
7	0.0	0.0	3.734E+01	4.055E+01	4.191E+01	4.139E+01	4.071E+01	0.0	4.479E+01	4.988E+01	5.088E+01
8	0.0	0.0	2.419E+01	2.868E+01	3.772E+01	2.949E+01	2.748E+01	0.0	3.001E+01	3.478E+01	4.256E+01
9	0.0	0.0	0.0	0.0	0.0	0.0	0.0	0.0	0.0	0.0	0.0
10	0.0	0.0	0.0	0.0	0.0	0.0	0.0	0.0	0.0	0.0	0.0
11	0.0	0.0	0.0	0.0	0.0	0.0	0.0	0.0	0.0	0.0	0.0
12	0.0	0.0	0.0	0.0	0.0	0.0	0.0	0.0	0.0	0.0	0.0
13	0.0	0.0	0.0	0.0	0.0	0.0	0.0	0.0	0.0	0.0	0.0
14	0.0	0.0	0.0	0.0	0.0	0.0	0.0	0.0	0.0	0.0	0.0
15	0.0	0.0	0.0	0.0	0.0	0.0	0.0	0.0	0.0	0.0	0.0
16	0.0	0.0	0.0	0.0	0.0	0.0	0.0	0.0	0.0	0.0	0.0
17	0.0	0.0	0.0	0.0	0.0	0.0	0.0	0.0	0.0	0.0	0.0
18	0.0	0.0	0.0	0.0	0.0	0.0	0.0	0.0	0.0	0.0	0.0
19	0.0	0.0	0.0	0.0	0.0	0.0	0.0	0.0	0.0	0.0	0.0

PLANE NUMBER 5

1	0.0	0.0	0.0	0.0	0.0	9.237E+01	8.437E+01	8.310E+01	8.226E+01	8.228E+01	8.228E+01
2	0.0	0.0	0.0	0.0	0.0	8.053E+01	7.314E+01	7.371E+01	7.392E+01	7.501E+01	7.517E+01
3	0.0	0.0	0.0	0.0	6.216E+01	6.000E+01	5.886E+01	6.248E+01	6.149E+01	6.372E+01	6.499E+01
4	0.0	0.0	0.0	0.0	0.0	0.0	0.0	0.0	0.0	0.0	0.0
5	0.0	0.0	5.903E+01	5.825E+01	5.862E+01	5.668E+01	5.828E+01	0.0	6.327E+01	6.797E+01	6.967E+01
6	0.0	0.0	6.521E+01	0.0	0.0	0.0	7.033E+01	0.0	7.902E+01	8.718E+01	8.766E+01
7	0.0	0.0	5.324E+01	5.716E+01	5.905E+01	5.842E+01	5.837E+01	0.0	6.437E+01	7.095E+01	7.232E+01
8	0.0	0.0	3.411E+01	3.992E+01	5.237E+01	4.110E+01	3.891E+01	0.0	4.256E+01	4.875E+01	5.955E+01
9	0.0	0.0	0.0	0.0	0.0	0.0	0.0	0.0	0.0	0.0	0.0
10	0.0	0.0	0.0	0.0	0.0	0.0	0.0	0.0	0.0	0.0	0.0
11	0.0	0.0	0.0	0.0	0.0	0.0	0.0	0.0	0.0	0.0	0.0
12	0.0	0.0	0.0	0.0	0.0	0.0	0.0	0.0	0.0	0.0	0.0
13	0.0	0.0	0.0	0.0	0.0	0.0	0.0	0.0	0.0	0.0	0.0
14	0.0	0.0	0.0	0.0	0.0	0.0	0.0	0.0	0.0	0.0	0.0
15	0.0	0.0	0.0	0.0	0.0	0.0	0.0	0.0	0.0	0.0	0.0
16	0.0	0.0	0.0	0.0	0.0	0.0	0.0	0.0	0.0	0.0	0.0
17	0.0	0.0	0.0	0.0	0.0	0.0	0.0	0.0	0.0	0.0	0.0
18	0.0	0.0	0.0	0.0	0.0	0.0	0.0	0.0	0.0	0.0	0.0
19	0.0	0.0	0.0	0.0	0.0	0.0	0.0	0.0	0.0	0.0	0.0

PLANE NUMBER 6

1	0.0	0.0	0.0	0.0	0.0	1.405E+02	1.291E+02	1.276E+02	1.267E+02	1.268E+02	1.268E+02
2	0.0	0.0	0.0	0.0	0.0	1.308E+02	1.221E+02	1.230E+02	1.246E+02	1.259E+02	1.259E+02
3	0.0	0.0	0.0	0.0	1.207E+02	1.164E+02	1.163E+02	1.183E+02	1.221E+02	1.243E+02	1.244E+02
4	0.0	0.0	0.0	0.0	0.0	0.0	0.0	0.0	0.0	0.0	0.0

Information Processing Center

5	0.0	0.0	1.105E+02	1.004E+02	9.917E+01	9.925E+01	1.116E+02	0.0	1.203E+02	1.239E+02	1.240E+02
6	0.0	0.0	9.385E+01	0.0	0.0	0.0	1.026E+02	0.0	1.145E+02	1.196E+02	1.199E+02
7	0.0	0.0	7.333E+01	7.530E+01	7.753E+01	7.713E+01	8.154E+01	0.0	8.942E+01	9.336E+01	9.484E+01
8	0.0	0.0	5.436E+01	6.059E+01	7.851E+01	6.248E+01	6.284E+01	0.0	6.831E+01	7.392E+01	8.944E+01
9	0.0	0.0	0.0	0.0	0.0	0.0	0.0	0.0	0.0	0.0	0.0
10	0.0	0.0	0.0	0.0	0.0	0.0	0.0	0.0	0.0	0.0	0.0
11	0.0	0.0	0.0	0.0	0.0	0.0	0.0	0.0	0.0	0.0	0.0
12	0.0	0.0	0.0	0.0	0.0	0.0	0.0	0.0	0.0	0.0	0.0
13	0.0	0.0	0.0	0.0	0.0	0.0	0.0	0.0	0.0	0.0	0.0
14	0.0	0.0	0.0	0.0	0.0	0.0	0.0	0.0	0.0	0.0	0.0
15	0.0	0.0	0.0	0.0	0.0	0.0	0.0	0.0	0.0	0.0	0.0
16	0.0	0.0	0.0	0.0	0.0	0.0	0.0	0.0	0.0	0.0	0.0
17	0.0	0.0	0.0	0.0	0.0	0.0	0.0	0.0	0.0	0.0	0.0
18	0.0	0.0	0.0	0.0	0.0	0.0	0.0	0.0	0.0	0.0	0.0
19	0.0	0.0	0.0	0.0	0.0	0.0	0.0	0.0	0.0	0.0	0.0

PLANE NUMBER 7

	1	2	3	4	5	6	7	8	9	10	11
1	0.0	0.0	0.0	0.0	0.0	1.621E+02	1.480E+02	1.458E+02	1.445E+02	1.445E+02	1.445E+02
2	0.0	0.0	0.0	0.0	0.0	1.507E+02	1.396E+02	1.404E+02	1.419E+02	1.433E+02	1.434E+02
3	0.0	0.0	0.0	0.0	1.406E+02	1.339E+02	1.326E+02	1.351E+02	1.388E+02	1.412E+02	1.413E+02
4	0.0	0.0	0.0	0.0	0.0	0.0	0.0	0.0	0.0	0.0	0.0
5	0.0	0.0	1.280E+02	1.159E+02	1.142E+02	1.138E+02	1.273E+02	0.0	1.369E+02	1.406E+02	1.408E+02
6	0.0	0.0	1.073E+02	0.0	0.0	0.0	1.169E+02	0.0	1.304E+02	1.355E+02	1.358E+02
7	0.0	0.0	8.582E+01	8.730E+01	8.972E+01	8.941E+01	9.510E+01	0.0	1.041E+02	1.080E+02	1.095E+02
8	0.0	0.0	7.506E+01	8.161E+01	1.015E+02	8.409E+01	8.541E+01	0.0	9.263E+01	9.879E+01	1.160E+02
9	0.0	0.0	0.0	0.0	0.0	0.0	0.0	0.0	0.0	0.0	0.0
10	0.0	0.0	0.0	0.0	0.0	0.0	0.0	0.0	0.0	0.0	0.0
11	0.0	0.0	0.0	0.0	0.0	0.0	0.0	0.0	0.0	0.0	0.0
12	0.0	0.0	0.0	0.0	0.0	0.0	0.0	0.0	0.0	0.0	0.0
13	0.0	0.0	0.0	0.0	0.0	0.0	0.0	0.0	0.0	0.0	0.0
14	0.0	0.0	0.0	0.0	0.0	0.0	0.0	0.0	0.0	0.0	0.0
15	0.0	0.0	0.0	0.0	0.0	0.0	0.0	0.0	0.0	0.0	0.0
16	0.0	0.0	0.0	0.0	0.0	0.0	0.0	0.0	0.0	0.0	0.0
17	0.0	0.0	0.0	0.0	0.0	0.0	0.0	0.0	0.0	0.0	0.0
18	0.0	0.0	0.0	0.0	0.0	0.0	0.0	0.0	0.0	0.0	0.0
19	0.0	0.0	0.0	0.0	0.0	0.0	0.0	0.0	0.0	0.0	0.0

PLANE NUMBER 8

	1	2	3	4	5	6	7	8	9	10	11
1	0.0	0.0	0.0	0.0	0.0	1.749E+02	1.584E+02	1.557E+02	1.540E+02	1.539E+02	1.539E+02
2	0.0	0.0	0.0	0.0	0.0	1.623E+02	1.493E+02	1.499E+02	1.513E+02	1.526E+02	1.526E+02
3	0.0	0.0	0.0	0.0	1.529E+02	1.444E+02	1.421E+02	1.447E+02	1.482E+02	1.504E+02	1.505E+02
4	0.0	0.0	0.0	0.0	0.0	0.0	0.0	0.0	0.0	0.0	0.0
5	0.0	0.0	1.390E+02	1.264E+02	1.243E+02	1.237E+02	1.366E+02	0.0	1.464E+02	1.500E+02	1.502E+02
6	0.0	0.0	1.166E+02	0.0	0.0	0.0	1.263E+02	0.0	1.404E+02	1.454E+02	1.457E+02
7	0.0	0.0	1.010E+02	1.013E+02	1.028E+02	1.037E+02	1.106E+02	0.0	1.208E+02	1.245E+02	1.251E+02
8	0.0	0.0	1.399E+02	1.451E+02	1.519E+02	1.492E+02	1.533E+02	0.0	1.657E+02	1.729E+02	1.762E+02
9	0.0	0.0	0.0	0.0	0.0	0.0	0.0	0.0	0.0	0.0	0.0
10	0.0	0.0	0.0	0.0	0.0	0.0	0.0	0.0	0.0	0.0	0.0
11	0.0	0.0	0.0	0.0	0.0	0.0	0.0	0.0	0.0	0.0	0.0
12	0.0	0.0	0.0	0.0	0.0	0.0	0.0	0.0	0.0	0.0	0.0
13	0.0	0.0	0.0	0.0	0.0	0.0	0.0	0.0	0.0	0.0	0.0
14	0.0	0.0	0.0	0.0	0.0	0.0	0.0	0.0	0.0	0.0	0.0
15	0.0	0.0	0.0	0.0	0.0	0.0	0.0	0.0	0.0	0.0	0.0
16	0.0	0.0	0.0	0.0	0.0	0.0	0.0	0.0	0.0	0.0	0.0
17	0.0	0.0	0.0	0.0	0.0	0.0	0.0	0.0	0.0	0.0	0.0
18	0.0	0.0	0.0	0.0	0.0	0.0	0.0	0.0	0.0	0.0	0.0
19	0.0	0.0	0.0	0.0	0.0	0.0	0.0	0.0	0.0	0.0	0.0

PLANE NUMBER 9

	1	2	3	4	5	6	7	8	9	10	11
1	0.0	0.0	0.0	0.0	0.0	1.826E+02	1.617E+02	1.577E+02	1.549E+02	1.544E+02	1.544E+02

Information Processing Center

Information Processing Center

2	0.0	0.0	0.0	0.0	0.0	1.686E+02	1.520E+02	1.518E+02	1.524E+02	1.533E+02	1.534E+02
3	0.0	0.0	0.0	0.0	1.630E+02	1.508E+02	1.456E+02	1.481E+02	1.503E+02	1.520E+02	1.521E+02
4	0.0	0.0	0.0	0.0	0.0	0.0	0.0	0.0	0.0	0.0	0.0
5	0.0	0.0	1.465E+02	1.355E+02	1.330E+02	1.317E+02	1.405E+02	0.0	1.491E+02	1.516E+02	1.517E+02
6	0.0	0.0	1.210E+02	0.0	0.0	0.0	1.297E+02	0.0	1.428E+02	1.467E+02	1.469E+02
7	0.0	0.0	1.102E+02	1.102E+02	1.113E+02	1.125E+02	1.191E+02	0.0	1.294E+02	1.324E+02	1.326E+02
8	0.0	0.0	1.835E+02	1.869E+02	1.894E+02	1.914E+02	1.969E+02	0.0	2.120E+02	2.189E+02	2.181E+02
9	0.0	0.0	0.0	0.0	0.0	0.0	0.0	0.0	0.0	0.0	0.0
10	0.0	0.0	0.0	0.0	0.0	0.0	0.0	0.0	0.0	0.0	0.0
11	0.0	0.0	0.0	0.0	0.0	0.0	0.0	0.0	0.0	0.0	0.0
12	0.0	0.0	0.0	0.0	0.0	0.0	0.0	0.0	0.0	0.0	0.0
13	0.0	0.0	0.0	0.0	0.0	0.0	0.0	0.0	0.0	0.0	0.0
14	0.0	0.0	0.0	0.0	0.0	0.0	0.0	0.0	0.0	0.0	0.0
15	0.0	0.0	0.0	0.0	0.0	0.0	0.0	0.0	0.0	0.0	0.0
16	0.0	0.0	0.0	0.0	0.0	0.0	0.0	0.0	0.0	0.0	0.0
17	0.0	0.0	0.0	0.0	0.0	0.0	0.0	0.0	0.0	0.0	0.0
18	0.0	0.0	0.0	0.0	0.0	0.0	0.0	0.0	0.0	0.0	0.0
19	0.0	0.0	0.0	0.0	0.0	0.0	0.0	0.0	0.0	0.0	0.0

PLANE NUMBER 10

1	0.0	0.0	0.0	0.0	0.0	2.094E+02	1.616E+02	1.518E+02	1.446E+02	1.427E+02	1.427E+02
2	0.0	0.0	0.0	0.0	0.0	1.860E+02	1.508E+02	1.477E+02	1.459E+02	1.460E+02	1.460E+02
3	0.0	0.0	0.0	0.0	2.034E+02	1.699E+02	1.545E+02	1.559E+02	1.558E+02	1.564E+02	1.565E+02
4	0.0	0.0	0.0	0.0	0.0	0.0	0.0	0.0	0.0	0.0	0.0
5	0.0	0.0	1.492E+02	1.447E+02	1.417E+02	1.390E+02	1.365E+02	0.0	1.412E+02	1.411E+02	1.411E+02
6	0.0	0.0	1.121E+02	0.0	0.0	0.0	1.178E+02	0.0	1.257E+02	1.264E+02	1.265E+02
7	0.0	0.0	1.028E+02	1.054E+02	1.064E+02	1.070E+02	1.094E+02	0.0	1.176E+02	1.186E+02	1.189E+02
8	0.0	0.0	1.912E+02	1.948E+02	1.985E+02	1.981E+02	2.017E+02	0.0	2.158E+02	2.221E+02	2.231E+02
9	0.0	0.0	0.0	0.0	0.0	0.0	0.0	0.0	0.0	0.0	0.0
10	0.0	0.0	0.0	0.0	0.0	0.0	0.0	0.0	0.0	0.0	0.0
11	0.0	0.0	0.0	0.0	0.0	0.0	0.0	0.0	0.0	0.0	0.0
12	0.0	0.0	0.0	0.0	0.0	0.0	0.0	0.0	0.0	0.0	0.0
13	0.0	0.0	0.0	0.0	0.0	0.0	0.0	0.0	0.0	0.0	0.0
14	0.0	0.0	0.0	0.0	0.0	0.0	0.0	0.0	0.0	0.0	0.0
15	0.0	0.0	0.0	0.0	0.0	0.0	0.0	0.0	0.0	0.0	0.0
16	0.0	0.0	0.0	0.0	0.0	0.0	0.0	0.0	0.0	0.0	0.0
17	0.0	0.0	0.0	0.0	0.0	0.0	0.0	0.0	0.0	0.0	0.0
18	0.0	0.0	0.0	0.0	0.0	0.0	0.0	0.0	0.0	0.0	0.0
19	0.0	0.0	0.0	0.0	0.0	0.0	0.0	0.0	0.0	0.0	0.0

PLANE NUMBER 11

1	0.0	0.0	0.0	0.0	0.0	2.295E+02	1.854E+02	1.765E+02	1.700E+02	1.683E+02	1.682E+02
2	0.0	0.0	0.0	0.0	0.0	2.084E+02	1.760E+02	1.730E+02	1.715E+02	1.716E+02	1.716E+02
3	0.0	0.0	0.0	0.0	2.300E+02	1.977E+02	1.834E+02	1.835E+02	1.848E+02	1.857E+02	1.857E+02
4	0.0	0.0	0.0	0.0	0.0	0.0	0.0	0.0	0.0	0.0	0.0
5	0.0	0.0	1.712E+02	1.659E+02	1.639E+02	1.621E+02	1.617E+02	0.0	1.665E+02	1.668E+02	1.668E+02
6	0.0	0.0	1.355E+02	0.0	0.0	0.0	1.403E+02	0.0	1.488E+02	1.498E+02	1.500E+02
7	0.0	0.0	1.242E+02	1.263E+02	1.277E+02	1.276E+02	1.302E+02	0.0	1.395E+02	1.410E+02	1.418E+02
8	0.0	0.0	2.089E+02	2.131E+02	2.268E+02	2.156E+02	2.182E+02	0.0	2.327E+02	2.403E+02	2.523E+02
9	0.0	0.0	0.0	0.0	0.0	0.0	0.0	0.0	0.0	0.0	0.0
10	0.0	0.0	0.0	0.0	0.0	0.0	0.0	0.0	0.0	0.0	0.0
11	0.0	0.0	0.0	0.0	0.0	0.0	0.0	0.0	0.0	0.0	0.0
12	0.0	0.0	0.0	0.0	0.0	0.0	0.0	0.0	0.0	0.0	0.0
13	0.0	0.0	0.0	0.0	0.0	0.0	0.0	0.0	0.0	0.0	0.0
14	0.0	0.0	0.0	0.0	0.0	0.0	0.0	0.0	0.0	0.0	0.0
15	0.0	0.0	0.0	0.0	0.0	0.0	0.0	0.0	0.0	0.0	0.0
16	0.0	0.0	0.0	0.0	0.0	0.0	0.0	0.0	0.0	0.0	0.0
17	0.0	0.0	0.0	0.0	0.0	0.0	0.0	0.0	0.0	0.0	0.0
18	0.0	0.0	0.0	0.0	0.0	0.0	0.0	0.0	0.0	0.0	0.0
19	0.0	0.0	0.0	0.0	0.0	0.0	0.0	0.0	0.0	0.0	0.0

PLANE NUMBER 12

1	0.0	0.0	0.0	0.0	0.0	0.0	0.0	0.0	0.0	0.0	0.0
---	-----	-----	-----	-----	-----	-----	-----	-----	-----	-----	-----

13	0.0	0.0	0.0	0.0	0.0	0.0	0.0	0.0	0.0	0.0	0.0
14	0.0	0.0	0.0	0.0	0.0	0.0	0.0	0.0	0.0	0.0	0.0
15	0.0	0.0	0.0	0.0	0.0	0.0	0.0	0.0	0.0	0.0	0.0
16	0.0	0.0	0.0	0.0	0.0	0.0	0.0	0.0	0.0	0.0	0.0
17	0.0	0.0	0.0	0.0	0.0	0.0	0.0	0.0	0.0	0.0	0.0
18	0.0	0.0	0.0	0.0	0.0	0.0	0.0	0.0	0.0	0.0	0.0
19	0.0	0.0	0.0	0.0	0.0	0.0	0.0	0.0	0.0	0.0	0.0

Information Processing Center

Information Processing Center

Information Processing Center

Information Processing Center

HOLY SAMPLE HOLDER, HF FIXED AT 12", B-SS BLADES AT 8", 24 ELEMENTS

SUMMARY TABLE OF NEUTRON LOSSES, ETC.

ZONE CLASS	FISSILE	FERTILE	INTERMEDIATE	OTHER	STRUCTURAL	SPECIAL	UNSPECIFIED	SUMS	CONV. RATIO	POWER (MW)	FISSILE (KG)
CORE	0.0	0.0	0.0	0.0	0.0	0.01312	0.00048	0.01360	0.0	1.29718E-01	0.0
H2O+AL	0.0	0.0	0.0	0.0	0.04875	0.0	0.0	0.04875	0.0	0.0	0.0
CORE	0.01546	0.31024	0.01103	0.04342	0.0	0.00763	-0.00000	0.38778	3.00505	3.58859E+00	0.0
D2O+H2O+AL	0.0	0.0	0.0	0.00397	0.01041	0.0	0.00443	0.01881	0.0	0.0	0.0
PB	0.0	0.0	0.0	0.0	0.0	0.0	0.0	0.0	0.0	0.0	0.0
CD+AL	0.0	0.0	0.0	0.0	0.0	0.0	0.0	0.0	0.0	0.0	0.0
AL	0.0	0.0	0.0	0.0	0.00226	0.0	0.03380	0.03606	0.0	0.0	0.0
D2O	0.0	0.0	0.0	0.0	0.0	0.0	0.0	0.0	0.0	0.0	0.0
CORE	0.0	0.0	0.0	0.0	0.00556	0.0	0.13443	0.13999	0.0	1.28169E+00	0.0
AL+H2O	0.0	0.0	0.0	0.0	0.05159	0.0	0.04055	0.09214	0.0	0.0	0.0
C	0.0	0.0	0.0	0.0	0.0	0.0	0.00730	0.00730	0.0	0.0	0.0
AL+D2O	0.0	0.0	0.0	0.0	0.0	0.0	0.00367	0.00367	0.0	0.0	0.0
H2O	0.0	0.0	0.0	0.0	0.0	0.0	0.00437	0.00437	0.0	0.0	0.0
AL+H2O	0.0	0.0	0.0	0.0	0.00736	0.0	0.0	0.00736	0.0	0.0	0.0
H2O	0.0	0.0	0.0	0.0	0.00791	0.0	0.02581	0.03372	0.0	0.0	0.0
CORE+AL-H2O	0.0	0.0	0.0	0.0	0.0	0.0	0.0	0.0	0.0	0.0	0.0
AL+H2O	0.0	0.0	0.0	0.0	0.0	0.0	0.00282	0.00282	0.0	0.0	0.0
AL+D2O+VOID	0.0	0.0	0.0	0.0006	0.0	0.0	0.00219	0.00225	0.0	0.0	0.0
AL+VOID	0.0	0.0	0.0	0.0	0.0	0.0	0.00137	0.00137	0.0	0.0	0.0
AL+D2O+VOID	0.0	0.0	0.0	0.00014	0.0	0.0	0.00619	0.00633	0.0	0.0	0.0
CORE-H2O	0.0	0.0	0.0	0.0	0.0	0.0	0.0	0.0	0.0	0.0	0.0
AL+H2O	0.0	0.0	0.0	0.0	0.0	0.0	0.0	0.0	0.0	0.0	0.0
VOID	0.0	0.0	0.0	0.0	0.0	0.0	0.0	0.0	0.0	0.0	0.0
H2O	0.0	0.0	0.0	0.0	0.0	0.0	0.0	0.0	0.0	0.0	0.0
H2O	0.0	0.0	0.0	0.0	0.0	0.0	0.0	0.0	0.0	0.0	0.0
HF+AL	0.0	0.0	0.0	0.0	0.00013	0.0	0.02016	0.02029	0.0	0.0	0.0
HF+AL	0.0	0.0	0.0	0.0	0.00016	0.0	0.01294	0.01310	0.0	0.0	0.0
B-SS	0.0	0.0	0.0	0.0	0.0	0.0	0.11369	0.11369	0.0	0.0	0.0
CD+AL	0.0	0.0	0.0	0.0	0.00001	0.0	0.00350	0.00351	0.0	0.0	0.0
OTHER LOSSES BASED ON START-OF-STEP TOTAL LOSSES 0.04311											
OVERALL	0.01546	0.31024	0.01103	0.04758	0.13413	0.02075	0.41769	1.00000	3.00505	4.99999E+00	0.0

END OF CASE - TOTAL CPU TIME WAS 1.61 MINUTES TOTAL CLOCK TIME WAS 3.10 MINUTES

*****THIS JOB WAS RUN ON 9/05/76 ON THE IBM 370/165*****

JOB ENDED NORMALLY