

MIT Open Access Articles

An Economics-Based Second Law Efficiency

The MIT Faculty has made this article openly available. **Please share** how this access benefits you. Your story matters.

Citation: Mistry, Karan, and John Lienhard. "An Economics-Based Second Law Efficiency." Entropy 15, no. 7 (July 12, 2013): 2736-2765.

As Published: <http://dx.doi.org/10.3390/e15072736>

Publisher: MDPI AG

Persistent URL: <http://hdl.handle.net/1721.1/81315>

Version: Final published version: final published article, as it appeared in a journal, conference proceedings, or other formally published context



Article

An Economics-Based Second Law Efficiency

Karan H. Mistry and John H. Lienhard V *

Department of Mechanical Engineering, Massachusetts Institute of Technology, Cambridge, MA 02139, USA; E-Mail: mistry@mit.edu

* Author to whom correspondence should be addressed; E-Mail: lienhard@mit.edu.

Received: 21 May 2013; in revised form: 6 July 2013 / Accepted: 8 July 2013 /

Published: 12 July 2013

Abstract: Second Law efficiency is a useful parameter for characterizing the energy requirements of a system in relation to the limits of performance prescribed by the Laws of Thermodynamics. However, since energy costs typically represent less than 50% of the overall cost of product for many large-scale plants (and, in particular, for desalination plants), it is useful to have a parameter that can characterize both energetic and economic effects. In this paper, an economics-based Second Law efficiency is defined by analogy to the exergetic Second Law efficiency and is applied to several desalination systems. It is defined as the ratio of the minimum cost of producing a product divided by the actual cost of production. The minimum cost of producing the product is equal to the cost of the primary source of energy times the minimum amount of energy required, as governed by the Second Law. The analogy is used to show that thermodynamic irreversibilities can be assigned costs and compared directly to non-energetic costs, such as capital expenses, labor and other operating costs. The economics-based Second Law efficiency identifies costly sources of irreversibility and places these irreversibilities in context with the overall system costs. These principles are illustrated through three case studies. First, a simple analysis of multistage flash and multiple effect distillation systems is performed using available data. Second, a complete energetic and economic model of a reverse osmosis plant is developed to show how economic costs are influenced by energetics. Third, a complete energetic and economic model of a solar powered direct contact membrane distillation system is developed to illustrate the true costs associated with so-called free energy sources.

Keywords: Second Law efficiency; irreversibilities; economics; desalination; cogeneration; least work of separation; cost

Nomenclature

<i>Roman symbols</i>		<i>Units</i>	<i>Subscripts</i>	
A	annualized cost	\$/yr	0	dead state
B	membrane distillation coefficient		1, 2	states 1 and 2
	kg/m ² Pa s		c	concentrate
C	cost	\$	e	electricity
c	specific heat	J/kg K	f	feed
c_i	cost of energy	\$/i	h	heat
d_{ch}	flow channel depth	m	least	reversible process in which all process streams cross the system boundary at the RDS
\dot{E}	energy flow rate	J/s	p	product
g	specific Gibbs free energy	J/kg	w	water
i	interest rate	%	ch	chemical
L	length	m	sep	separation
\dot{m}	mass flow rate	kg/s	<i>Superscripts</i>	
n	plant lifetime	yr	min	minimum value at infinitesimal recovery
p	pressure	kPa	<i>Acronyms</i>	
\dot{Q}	rate of heat transfer	J/s	AF	availability factor
r	recovery ratio	kg _{product} /kg _{feed}	CAPEX	capital expenses
\dot{S}_{gen}	rate of entropy generation	J/s K	DCMD	direct contact membrane distillation
R_R	replacement rate	%	ERD	energy recovery device
s	specific entropy	J/kg K	GOR	gained output ratio
s_{gen}	specific entropy generation	J/kg K	HP	high pressure
T	temperature	K	MED	multiple effect distillation
\dot{V}	volumetric flow rate	m ³ /s	MSF	multistage flash
v	specific volume	m ³ /kg	OPEX	operating expenses
\dot{W}	rate of work transfer	J/s	PR	performance ratio
w	width	m	PV	photovoltaic
y	salinity	kg _{solutes} /kg _{solution}	PX	pressure exchanger
<i>Greek</i>		<i>Units</i>	RDS	restricted dead state
γ_{-i}	cost scaling function	\$/m ³	RO	reverse osmosis
Δ	change in a variable		SEC	specific electricity consumption
η	First Law efficiency	-		kWh _e /m ³
η_{II}	Second Law/exergetic efficiency	-	SWRO	seawater reverse osmosis
$\eta_{II,\$}$	economics-based Second Law efficiency	-	TDS	total dead state
			TOTEX	total expenses
$\dot{\Xi}$	rate of exergy	J/s	TTD	terminal temperature difference
ξ	specific exergy	J/kg		
ρ	density	kg/m ³		
ϕ_i	cost scaling function	-		

1. Introduction

Substantial research in desalination has been conducted in recent decades in order to develop more efficient and economical technologies, both to provide potable water and to remediate industrial process waters [1,2].

Several energetics-based performance parameters are regularly used in the desalination industry in order to describe the energy requirements of various technologies and to compare the energy efficiency of systems. These performance parameters include specific electricity consumption (SEC), gained output ratio (GOR), performance ratio (PR), least heat and least work, and Second Law efficiency [3,4]. While all of these energetic parameters are useful, unfortunately, they all have certain limitations. For example, parameters such as SEC and GOR are based purely on energy consumption and fail to capture thermodynamic limits on system performance. Second Law efficiency references the energy consumed to the theoretical minimum energy requirements (minimum least work of separation) and, therefore, is an expression of how close a real-world system is to achieving the reversible limit of energy efficiency. However, this parameter is also limited in that it only captures exergetic effects. Since it is only a reflection of exergetic costs, optimization based on Second Law efficiency alone will result in impractical systems requiring very large, or infinite, transfer areas (heat transfer surfaces, membranes, *etc.*).

All real-world systems are ultimately limited by the total cost of the end product. The cost of a system is a function of many parameters, of which energy is just one. For typical large-scale desalination plants, the cost of energy is less than 50% of the overall cost [5,6]. Therefore, it is useful to have a parameter that can adequately capture both energetic and economic effects.

An economics-based Second Law efficiency that is defined in analogy to the standard exergetic Second Law efficiency is such a parameter that can be used to consider both energetic and economic factors and can be used to compare various systems. Additionally, by subdividing the energy costs based on individual sources of irreversibility, as is typically done in an exergy analysis, the cost of thermodynamic irreversibility can be compared to other non-energetic costs such as capital expenses, labor, and so on. Then, the greatest sources of economic loss can be identified. While thermoeconomics and the costing of exergy destruction are not new ideas, the use of an efficiency parameter to relate actual costs to idealized costs is novel [7–13].

In this study, a method for defining and evaluating an economics-based Second Law efficiency is introduced and demonstrated for multiple desalination technologies. While only desalination technologies are considered herein, these methods are completely general and can be applied to any type of system.

2. Second Law Efficiency for a Chemical Separator

Second Law (or exergetic) efficiency is a commonly employed metric that measures the thermodynamic reversibility of a system. While First Law efficiency measures the amount of an energy source that is put to use, Second Law efficiency (η_{II}) measures the extent of irreversible losses within a system. As a result, a completely reversible system will have a Second Law efficiency of one even though the First Law efficiency is likely to be lower. Bejan [14] defines the exergetic efficiency as the ratio of the exergy of the process products to the process fuel. In other words, the exergetic efficiency

is the ratio of the useful exergy of the outputs of the process ($\dot{\Xi}_{\text{out,useful}}$) to the exergy of the process inputs ($\dot{\Xi}_{\text{in}}$):

$$\eta_{II} \equiv \frac{\dot{\Xi}_{\text{out,useful}}}{\dot{\Xi}_{\text{in}}} = 1 - \frac{\dot{\Xi}_{\text{destroyed}} + \dot{\Xi}_{\text{lost}}}{\dot{\Xi}_{\text{in}}} \quad (1)$$

The second equality in Equation (1) is valid since the useful exergy out is equal to the exergy in minus the sum of the exergy destroyed ($\dot{\Xi}_{\text{destroyed}}$) and the exergy lost ($\dot{\Xi}_{\text{lost}}$). Exergy destroyed represents lost available work due to irreversibilities within the system. Exergy lost represents lost available work due to discarding streams to the environment that carry exergy. Note that when the material inputs to the system are taken to be at equilibrium with the environment, $\dot{\Xi}_{\text{in}}$ equals $\dot{\Xi}_{\dot{W}_{\text{sep}}}$, $\dot{\Xi}_{\dot{Q}_{\text{sep}}}$ or $\dot{\Xi}_{\text{fuel}}$, depending on the energy input.

Mistry *et al.* [3] discussed many of the subtleties associated with the Second Law efficiency as applied to a desalination system and showed that the useful exergy output of the system is equal to the minimum least work of separation. In order to define the minimum least work of separation, consider a black box desalination system as illustrated in Figure 1. By applying the First and Second Laws of Thermodynamics, conservation of mass, requiring all streams to cross the system boundary at the restricted dead state (RDS, thermal and mechanical equilibrium with the environment) and assuming steady state and reversible behavior, the least work of separation can be shown to be equal to [3,4,15–17]:

$$\frac{\dot{W}_{\text{least}}}{\dot{m}_p} = (g_p - g_c) - \frac{1}{r} (g_f - g_c) \quad (2)$$

where the mass-based recovery ratio is defined as:

$$r \equiv \frac{\dot{m}_p}{\dot{m}_f} = \frac{\text{mass flow rate of product}}{\text{mass flow rate of feed}} \quad (3)$$

and the Gibbs free energy of each of the streams is evaluated as a function of ambient temperature (T_0) and salinity (y_i). Using mass balance on the dissolved solids, the salinity of the concentrate stream is given as:

$$y_c = \frac{y_f - r y_p}{1 - r} \quad (4)$$

Note that while work is the only energy input, in order to fulfill the First and Second Laws of Thermodynamics and to allow all streams to enter and exit the control volume at ambient temperature, heat transfer must be allowed with the environment (\dot{Q}_0).

Figure 1. A control volume for an arbitrary black box chemical separator powered by work only. Heat transfer with the environment is allowed to ensure all streams leave the control volume at the restricted dead state.

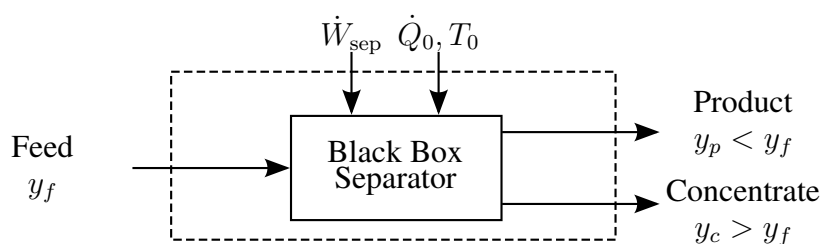

The minimum least work of separation is equal to the least work of separation at infinitesimal recovery and is equal to the true exergetic value of the product of a chemical separation process [3,4]:

$$\dot{W}_{\text{least}}^{\text{min}} \equiv \lim_{r \rightarrow 0} \dot{W}_{\text{least}} = \lim_{r \rightarrow 0} \dot{\Xi}_{\text{least}} \equiv \dot{\Xi}_{\text{least}}^{\text{min}} \quad (5)$$

Mistry *et al.* [3] provided definitions for the Second Law efficiency of desalination systems in terms of the minimum least work ($\dot{W}_{\text{least}}^{\text{min}}$) and in terms of the minimum least heat ($\dot{Q}_{\text{least}}^{\text{min}}$). Similarly, Mistry and Lienhard [4] introduced the minimum least fuel, and these three definitions for η_{II} are:

$$\eta_{II} = \frac{\dot{W}_{\text{least}}^{\text{min}}}{\dot{W}_{\text{sep}}} \quad \eta_{II} = \frac{\dot{Q}_{\text{least}}^{\text{min}}}{\dot{Q}_{\text{sep}}} \quad \eta_{II} = \frac{\dot{m}_{\text{least}}^{\text{min}}}{\dot{m}_{\text{sep}}} \quad (6)$$

Mistry and Lienhard [4] also generalized the expressions for Second Law efficiency given in Equation (6) in order to allow for systems that are powered by any combination of energy inputs. The generalized equation is defined as:

$$\eta_{II} = \frac{\dot{\Xi}_{\text{least}}^{\text{min}}}{\dot{\Xi}_{\text{sep}}} = \frac{\dot{\Xi}_{\text{least}}^{\text{min}}}{\dot{\Xi}_{\dot{W}} + \dot{\Xi}_{\dot{Q}} + \dot{\Xi}_{\text{ch}}} \quad (7)$$

where:

$$\dot{\Xi}_{\dot{W}} = \dot{W} \quad \dot{\Xi}_{\dot{Q}} = \eta_{\text{Carnot}} \dot{Q} \quad \dot{\Xi}_{\text{ch}} = \xi_{\text{fuel}} \dot{m}_{\text{fuel}} \quad (8)$$

Care must be taken when evaluating the denominators in Equation (7). For stand-alone systems, the denominator is simply the sum of the exergetic inputs. For systems that are part of a cogeneration scheme, it is essential that only primary energy inputs are considered [4]. For the case of a desalination plant operating in conjunction with a power plant, this means that the exergetic input is the additional heat input required by the power plant in order to produce the necessary work and steam to drive the desalination process.

Equation (7) is completely general and is written in terms of the various exergy inputs that can be provided to a system. It is particularly useful when trying to evaluate the system in terms of the inputs. An alternative way to express the Second Law efficiency is in terms of the losses that occur within the system. That is, in terms of the exergy destruction. As discussed by Mistry *et al.* [3], it is essential that all sources of irreversibility are considered, including those that occur outside of the system as a result of discharging streams that are at disequilibrium with the environment:

$$\eta_{II} = \frac{\dot{\Xi}_{\text{least}}^{\text{min}}}{\dot{\Xi}_{\text{sep}}} = \frac{\dot{\Xi}_{\text{least}}^{\text{min}}}{\dot{\Xi}_{\text{least}}^{\text{min}} + T_0 \dot{S}_{\text{gen}}^{\text{TDS}}} = \frac{\dot{\Xi}_{\text{least}}^{\text{min}}}{\dot{\Xi}_{\text{least}}^{\text{min}} + T_0 \dot{S}_{\text{gen}}^{\text{RDS}}} \quad (9)$$

The two forms of Equation (9) are provided to show that the entropy destroyed in taking the concentrate stream to the total dead state (TDS, thermal, mechanical, and chemical equilibrium with the environment) must be considered [3].

While Equations (7) and (9) are useful for understanding and characterizing the exergetic inputs and thermodynamic irreversibilities, respectively, they are both limited in that they only provide information about the energetic requirements of a system. Even though it is important to understand energetic requirements and it is typically desired to minimize the requirements through the reduction of irreversibilities, economic constraints often result in system designs that are not optimized from a purely energetic point of view. Therefore, it is desirable to have a parameter that can account for both energetic factors and economic factors. Such a parameter is proposed in the following section.

3. Derivation of an Economics-Based Second Law Efficiency

Before the economics-based Second Law efficiency can be defined, one must consider what Equation (7) means physically. Expressed in words:

$$\eta_{II} \equiv \frac{\text{Useful exergetic value of the product}}{\text{Actual exergetic value of all inputs}} \quad (10)$$

As discussed by many authors [3,4,12,14,18], η_{II} is useful since it expresses how efficiently a process is able to produce output when compared to the limitations imposed by the Second Law of Thermodynamics. However, as explained above, energetics alone are not fully descriptive in characterizing practical, thermodynamic systems. Instead, energetic efficiency needs to be considered while accounting for economic costs. Unfortunately, improved efficiency typically comes at the expense of increased capital costs. Therefore, it is important to maintain a trade-off between the objectives of maximum energy efficiency and minimum cost.

Now, consider a modification of the existing definition for Second Law efficiency. As shown in Equation (10), η_{II} is the ratio of two exergetic quantities, measured in J or W. By analogy, a new economics-based Second Law efficiency, denoted $\eta_{II,\$}$, is introduced in the form of a ratio of quantities measured in currency (*e.g.*, US dollars):

$$\eta_{II,\$} \equiv \frac{\text{Minimum cost of producing product}}{\text{Actual cost of producing product}} \quad (11)$$

In order to properly define $\eta_{II,\$}$, both the numerator and denominator of Equation (11) must be carefully analyzed.

3.1. Minimum Cost of Producing a Product

Comparing Equations (10) and (11), it is clear that the minimum cost of producing product should be defined by analogy to the useful exergetic value of the product. Therefore, the cost function should be related to the exergetic cost of producing the product, as defined by thermodynamics. Note that since the price of the product is not a function of the system itself, but rather, it is a function of the current economic market, product price is not an appropriate metric to use here.

According to thermodynamics, the only exergetic cost is for the exergy inputs. Thermodynamics cannot place a limit on other costs, such as capital expenses, labor, and interest rates, since these costs are a function of economic markets, not of inherent system properties. Additionally, under ideal conditions of infinite plant life and infinitesimal interest rate, the amortization factor goes to zero:

$$\lim_{\substack{i \rightarrow 0 \\ n \rightarrow \infty}} \frac{i(1+i)^n}{(1+i)^n - 1} = 0 \quad (12)$$

Therefore, the minimum cost of production is related to the required energy of separation. When exergy is needed, it is purchased in terms of energy, not exergy. That is, electricity (work) is typically sold per kWh and thermal energy is typically sold per BTU or therm. Therefore, the minimum cost should be expressed in terms of the primary energy input (not exergy) and the cost of that energy input. Since the cost of each specific form of energy is tied to many factors, it may not be directly related to the exergetic

value of the energy. The minimum least work of separation represents the least amount of work required to produce product, and therefore, this quantity should be used. Similarly, the minimum least heat or the minimum least mass of fuel can be used for systems that are driven using heat or fuel. Thus:

$$\text{Minimum cost of producing product with work} = c_e \dot{W}_{\text{least}}^{\min} \quad (13)$$

$$\text{Minimum cost of producing product with heat} = c_h \dot{Q}_{\text{least}}^{\min} \quad (14)$$

$$\text{Minimum cost of producing product with fuel} = c_{\text{fuel}} \dot{m}_{\text{least}}^{\min} \quad (15)$$

where c_e , c_h , and c_{fuel} are the costs of electricity, heat, and fuel, respectively. These cost functions will vary from location to location and should be equal to the actual cost functions that a plant at that location would have to pay for the respective type of energy.

Note that while the least work and least heat are related through the Carnot efficiency ($\dot{W}_{\text{least}} = \eta_{\text{Carnot}} \dot{Q}_{\text{least}}$), the same is not true for the cost functions ($c_e \neq c_h / \eta_{\text{Carnot}}$). As a result, it is clear that the values obtained through evaluation of Equations (13) to (15) will all be different. This is to be expected since the price of various energy inputs can vary substantially as a function of numerous factors, including, but not limited to, availability, state of the economy, political stability, and regulatory policies. In order to account for the fact that each primary fuel has a different cost associated with it, $\eta_{II,\$}$ cannot be simplified to one generic equation in the same manner that η_{II} is in Equation (7). Instead, there will be three definitions based each on work, heat, or fuel, analogous to the expressions in Equation (6):

$$\eta_{II,\$} = \frac{c_e \dot{W}_{\text{least}}^{\min}}{\text{Total Cost}} \quad \eta_{II,\$} = \frac{c_h \dot{Q}_{\text{least}}^{\min}}{\text{Total Cost}} \quad \eta_{II,\$} = \frac{c_{\text{fuel}} \dot{m}_{\text{least}}^{\min}}{\text{Total Cost}} \quad (16)$$

At this point, it is important to emphasize that even for fixed total costs, the value of $\eta_{II,\$}$ will be different depending on which of the three expressions in Equation (16) is used. This raises a problem as the value of $\eta_{II,\$}$ strongly depends on the selection of the primary energy input and therefore, a way to select which expression to use must be determined. Three possible options include: use the minimum value of the three expressions; always use the work, heat or fuel-based definition; or use the definition based on the primary fuel source to be used for the given system. Each of these options is considered.

The first option is to always use the minimum value of the cost of energy times the respective energy source. From a purely Second Law and reversibility point of view, this would technically give the lowest cost of desalination (analogous to the lowest energy of separation), regardless of energy input. However, the physical meaning of this selection (or lack thereof) must be considered. As an example, reverse osmosis (RO) plants are powered (exclusively) using electricity. However, at the location of a given RO plant, the cost of low temperature steam might be substantially less than that of electricity such that $c_h \dot{Q}_{\text{least}}^{\min}$ is less than $c_e \dot{W}_{\text{least}}^{\min}$. In this instance, using option one, the numerator for the economic Second Law efficiency should be evaluated in terms of heat. Unfortunately, the problem with evaluating it in this manner is that the cost of heat is completely irrelevant to an RO plant's operational costs. Therefore, $\eta_{II,\$}$ defined based on this energy input is equally irrelevant, and this approach should not be used.

The second option is to always use one of the expressions given in Equation (16), regardless of the system being considered. Always using work is relatively simple and straightforward, and it has the benefit that the exergetic value of work is the value of work itself. Additionally, work is a quantity that is simple to think about and does not come with the added complication of defining the temperature

at which heat is transferred into the system. Unfortunately, it is not necessarily useful to compare thermal energy costs to the cost of electricity since thermal energy may be available under conditions very different than those associated with electricity generation; and, it is definitely not useful to compare off-grid systems (such as solar driven systems) to a non-existent electricity source. For similar reasons, always using heat or fuel costs is also impractical in various situations. This approach introduces the same problem as discussed previously: if the primary energy considered is not relevant to the actual system's operating costs, then the parameter has no physical meaning.

The third option is to use the cost of energy of the primary energy source times the minimum amount of that energy source required for the separation process. Using this method has several advantages. Principally, evaluating the numerator in this manner will ensure that $\eta_{II,\$}$ is always scaled to the primary energy expense. For example, multiple effect distillation (MED) requires both thermal and electrical energy input. As a distillation (thermal) process, steam is the primary energy source used for driving separation. However, since energy recovery can be enhanced by operating at reduced pressure, electrical work in the form of pumping is needed to pump the product and brine streams back to atmospheric pressure. Additionally, pump work is required to overcome various frictional losses internal to the system. From an ideal thermodynamic point of view, distillation processes are driven using heat transfer alone. That is, the minimum energy required for a distillation processes is measured by the minimum least heat. The pump work required to maintain sub-atmospheric conditions and to overcome viscous losses clearly represent excess energy required beyond the reversible limit, as a result of system design and irreversibilities. Therefore, the cost of said heat transfer alone should be the numerator for $\eta_{II,\$}$. Thus, $\eta_{II,\$}$ can be generalized to:

$$\eta_{II,\$} = \frac{(c\dot{E}_{\text{least}}^{\text{min}})_{\text{primary energy source}}}{\text{Total Cost}} \quad (17)$$

There is a special case that must be considered explicitly at this point. From Equation (17), it is seen that if there is a “free” source of energy, then $\eta_{II,\$}$ will always equal zero. This implies that that any system operating that uses the supposedly “free” energy will always have a zero economic Second Law efficiency and be lesser-performing than any other system where energy has a finite cost. However, there is a fundamental problem with the notion of “free energy” that must be addressed.

In defining Equation (17), there is an inherent assumption that the system being considered exists in an energy resource-constrained environment. When resources are constrained, they are given finite prices based on the laws of supply and demand. So-called renewable energies, such as solar and wind power, are available from the environment at some rate, and cannot be depleted by ongoing use. Consequently, they are sometimes regarded as free sources of energy. However, although these energies may exist freely in the environment, harvesting and using them requires (often substantial) capital and operating investment, which must be amortized into the unit cost of energy from these sources. More specifically, if a plant uses solar-generated electricity, then a solar collection system, including photovoltaic panels, electronics, storage, and so on, is required. The additional expense for the hardware is the actual cost of the “free” solar energy, and the amortized value of this expense should be used as the cost function in the numerator of Equation (17). An example of a solar powered system is considered in the next section in order to demonstrate this calculation.

Now that the numerator has been defined, the total costs in the denominator are considered.

3.2. Actual Cost of Producing a Product

In the preceding section, it was shown that the numerator of $\eta_{II,\$}$ should be defined analogously to the numerator of η_{II} . Comparing Equations (10) and (11), it is clear that the denominators are also defined analogously. For η_{II} , it is the total exergetic input, and for $\eta_{II,\$}$, it is the total cost. From Equation (7), the total exergetic input is:

$$\text{Total exergetic input: } \dot{\Xi}_{\text{sep}} = \dot{W} + \eta_{\text{Carnot}}\dot{Q} + \xi_{\text{fuel}}\dot{m}_{\text{fuel}} \tag{18}$$

By analogy, the total cost of all of the energy inputs is defined as:

$$\text{Total cost of energy inputs: } = c_e\dot{W} + c_h\dot{Q} + c_{\text{fuel}}\dot{m}_{\text{fuel}} \tag{19}$$

where c_e , c_h , and c_{fuel} are the costs of work, heat, and fuel, respectively. The primary difference between Equations (18) and (19) (other than the obvious unit difference) is that each of the three terms (\dot{W} , \dot{Q} , and \dot{m}_{fuel}) are weighted differently. In Equation (18), the heat and fuel terms are weighted using exergetic parameters (Carnot efficiency and exergy value of fuel, respectively), whereas in Equation (19), all three terms are weighted using their respective cost values (in terms of dollars per kWh or dollars per kg).

At this point, a rudimentary definition for $\eta_{II,\$}$ can be introduced that is strictly analogous to η_{II} , as defined by Equation (7):

$$\eta_{II,\$} = \frac{(c\dot{E}_{\text{least}}^{\text{min}})_{\text{primary energy source}}}{c_e\dot{W} + c_h\dot{Q} + c_{\text{fuel}}\dot{m}_{\text{fuel}}} \tag{20}$$

If, for sake of argument, it is assumed that work is the primary energy source, the above equation reduces to:

$$\eta_{II,\$} = \frac{\dot{W}_{\text{least}}^{\text{min}}}{\dot{W} + \frac{c_h}{c_e}\dot{Q} + \frac{c_{\text{fuel}}}{c_e}\dot{m}_{\text{fuel}}} \tag{21}$$

As expected, the only difference between this expression and Equation (7) is the weighting of the heat and fuel terms in the denominator. Depending on the ratio of the cost of heat and fuel to electricity, these terms will have more or less weight. Ultimately, this expression does not provide substantially more information than one can obtain from studying η_{II} . In order to make $\eta_{II,\$}$ useful, the expression needs to be further developed.

One of the limiting factors of any Second Law analysis is that it is only able to provide information about the exergetics of the process since it is a direct application of the First and Second Laws of Thermodynamics. This is made clear by the fact that all of the terms in Equation (7) are in units of energy (or power). For many large-scale desalination systems, the energy cost typically represents only about a third to half of the overall costs [5,6], so looking at a purely exergetic parameter fails to capture many of the practical considerations that are necessary for selecting a technology and designing a plant. Some of the other costs include, but are not limited to, capital costs and operating costs (consumables, maintenance, labor).

Since the preliminary definition of $\eta_{II,\$}$ is already written in terms of quantities that are expressed in dollars, it is trivial to add additional costs to the denominator in order to get the actual total cost of producing product:

$$\text{Total cost water} = \underbrace{c_e\dot{W} + c_h\dot{Q} + c_{\text{fuel}}\dot{m}_{\text{fuel}}}_{\text{cost of energy inputs}} + C_{\text{CAPEX}} + C_{\text{OPEX}} + \dots \tag{22}$$

Now that the total cost of producing product has been identified, the proper definition of the economics-based Second Law efficiency is obtained:

$$\eta_{II,\$} = \frac{(c\dot{E}_{\text{least}}^{\min})_{\text{primary energy source}}}{c_e\dot{W} + c_h\dot{Q} + c_{\text{fuel}}\dot{m}_{\text{fuel}} + C_{\text{CAPEX}} + C_{\text{OPEX}} + \dots} \quad (23)$$

This expression represents the efficiency, from a thermodynamic and economic point of view, with which a system is able to produce product. Since η_{II} does not include any non-energetic terms, it is clear that $\eta_{II,\$}$ will always be less than η_{II} .

An additional useful analogy can be made. As shown above, there are two useful ways for writing η_{II} , one in terms of the exergetic input [Equation (7)] and another in terms of the exergy destruction [Equation (9)]. Using the exergy destruction approach, $\eta_{II,\$}$ is rewritten:

$$\eta_{II,\$} = \frac{(c\dot{E}_{\text{least}}^{\min})_{\text{primary energy source}}}{(cE_{\text{least}}^{\min}) + \sum_i c_i T_0 \dot{S}_{\text{gen},i} + C_{\text{CAPEX}} + C_{\text{OPEX}} + \dots} \quad (24)$$

When considering $\eta_{II,\$}$ from this point of view, it is clear that all non-energetic costs represent a “loss” to the system from a purely thermodynamic point of view. Therefore, the non-energetic terms can be combined with and compared to the entropy generation terms. In doing so, it becomes easy to compare the relative effects of each of the sources of losses and to understand which parts of a system require the most attention. For example, one could compare the cost of the additional energy needed to account for the losses in a heat transfer process to the operating costs associated with consuming chemicals. Depending on which loss (on a cost basis) is more significant, a designer can decide how to further optimize the process in order to reduce the overall cost of the product.

In Section 4, Equations (23) and (24) are applied to various desalination systems in order to illustrate how they can be used.

3.3. Generalized to Cogeneration Systems

Cogeneration systems, by definition, generate multiple products with economic value. Therefore, multiple terms must be included in the definition of an economics-based Second Law efficiency for cogeneration systems. In the case of water and power cogeneration, $\eta_{II,\$}$ could be written in the form of:

$$\eta_{II,\$} = \frac{\text{Minimum cost of producing electricity} + \text{Minimum cost of desalinating water}}{\text{Actual cost of producing both}} \quad (25)$$

Some care is needed when considering the numerator in Equation (25), and in particular, the minimum cost of desalination water. Since the desalination plant is powered using energy derived from some primary energy input to the larger cogeneration system, the cost scaling function on the minimum least energy must be based on the cost of the primary energy. This is equivalent to the evaluation of η_{II} for desalination plants in cogeneration systems, as discussed by Mistry and Lienhard [4]. A methodology for evaluating the primary energy input to a desalination plant in a larger cogeneration system is presented in [4,19]. For simplicity, all of the examples considered in this paper are stand-alone desalination systems.

4. Application to Various Desalination Systems

In order to illustrate the application of Equations (23) and (24), energetic and economic analysis of several desalination systems are considered. First, a simplified calculation of η_{II} and $\eta_{II,\$}$ is performed for a multistage flash (MSF) plant and an MED plant using cost data available in the literature coupled with some simple approximations. Second, a much more detailed analysis of an RO system is performed in which the energetics are modeled by evaluating all of the irreversibilities in the system. The energetic model is coupled with a full cost model in order to show how economic costs are influenced by energetics. Third, a complete energetic and economic model of a solar powered direct contact membrane distillation (DCMD) is analyzed in order to demonstrate how systems powered using “free” energy should be studied.

4.1. Multistage Flash and Multiple Effect Distillation

MSF and MED are the two most common thermal desalination technologies [20]. Both are distillation methods in which the overall energy requirements are reduced through the use of energy recovery in each stage or effect of the system [21]. Cost information for representative 100,000 m³/d MSF and MED plants is provided by [22–26]. It is shown that the total cost of water production for the MSF and MED plants is \$0.89/m³ and \$0.72/m³. A breakdown of the costs is provided in Table 1. Additionally, the thermal and electrical energy requirements are provided.

Table 1. Breakdown of costs for a 100,000 m³/d multistage flash (MSF) and multiple effect distillation (MED) system [22].

	MSF	MED
Costs [\$/m ³]:		
Amortization	0.29	0.22
Maintenance	0.01	0.01
Chemical	0.05	0.08
Labor	0.08	0.08
Thermal energy	0.27	0.27
Electrical energy	0.19	0.06
Total	0.89	0.72
Energy requirements:		
Thermal energy [kWh _t /m ³]	78	69
Electrical energy [kWh _e /m ³]	4.0	1.0

Using the information in Table 1, it is possible to calculate both η_{II} and $\eta_{II,\$}$ as well as to compare all of the contributions to the total cost of producing water for the two systems provided some additional assumptions are made. The feed is assumed to be standard seawater at 25 °C and 35 g/kg [27,28] while

the steam temperature is assumed to be 100 °C. Note that the minimum least heat of separation is a function of steam temperature, so the exact values found in the following calculation are subject to change based on the actual (but unreported) steam temperature. However, since this example is used to demonstrate a methodology, rather than to draw significant comparisons between the two plants, this broad approximation is deemed acceptable. Finally, it is assumed that thermal energy is the primary energy input to the system. While MSF and MED plants are typically operated in cogeneration schemes, without further information, it is not possible to characterize the actual conversion efficiencies involved in the cogeneration power plant [4].

Using the generalized least energy of separation equation from Mistry and Lienhard [4]:

$$\underbrace{\dot{W} + \sum_{l=1}^p \left(1 - \frac{T_0}{T}\right) \dot{Q}_l}_{\text{energy inputs/outputs}} + \underbrace{\sum_{\text{in-out}} \dot{N} \bar{\xi}(T, p, N_i)}_{\text{fuel and exhaust streams}} = \underbrace{\sum_{\text{out-in}} \dot{N} \bar{g}(T_0, p_0, N_i)}_{\text{process streams}} \quad (26)$$

the least heat of separation is equal to the least work of separation divided by Carnot efficiency. Using Equation (2) and a standard seawater property package [27,28], the minimum least heat of separation for seawater using a steam temperature of 100 °C is 13.5 kJ/kg (3.7 kWh_t/m³) [22].

The price of both the thermal and electrical energy is evaluated by dividing the cost by the energy requirements. Note that the cost of energy is heavily dependent on location and source. Therefore, it is not expected that the cost of heat and electricity will be the same for the two plants considered. For MSF, this corresponds to heat and electricity prices of \$0.0034/kWh_t and \$0.0467/kWh_e, respectively. For MED, this corresponds to \$0.0040/kWh_t and \$0.0576/kWh_e.

Finally, the total energy input for both systems is equal to the sum of the exergies of the heat and work. Expressed in terms of heat (*i.e.*, $Q + W/\eta_{\text{Carnot}}$), the effective thermal input to the MSF and MED systems is 97.9 kWh_t/m³ and 74.0 kWh_t/m³, respectively. Using these values coupled with the minimum least heat of separation, η_{II} for the MSF and MED plants is 3.8% and 5.1%, respectively.

Similarly, $\eta_{II,\$}$ can be evaluated by multiplying the price of the primary energy (heat for thermal systems) and the minimum least heat of separation and dividing the result by the total cost of water production. Using the prices for heat determined above, $\eta_{II,\$}$ for the MSF and MED plants is evaluated to be 1.4% and 2.1%, respectively. The specific breakdown of the costs, as shown in Table 1, is shown in Figure 2.

The values of $\eta_{II,\$}$ found above are evaluated using Equation (23). If instead, Equation (24) is used, then the cost of the energetic input can be split into the cost of providing the minimum least heat of energy plus the sum of the costs of providing extra energy required to account for all of the thermodynamic irreversibilities. The results are shown in Figure 3.

From Figure 3, it is clear that the cost of excess energy required by the irreversibilities is the single greatest source of the total cost of producing water for these two representative MSF and MED plants. Given more detailed information about the systems in question, the irreversibilities could be further subdivided in order to isolate the specific source of loss. Then, a system designer could identify which components or processes should be addressed in order to try to reduce the overall system cost.

At this point, it should be reiterated that these are just representative numbers and that these two examples (and the following examples) are not meant to be used to draw sweeping conclusions about the superiority of one technology over another.

Figure 2. Breakdown of costs associated with the production of water using MSF and MED.

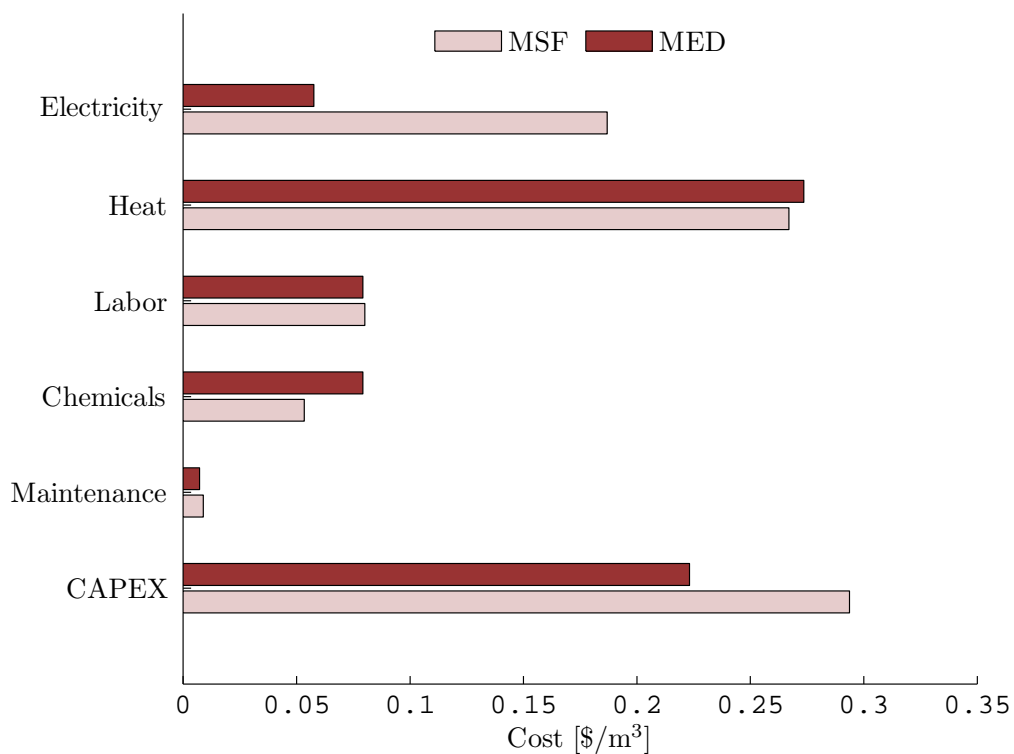
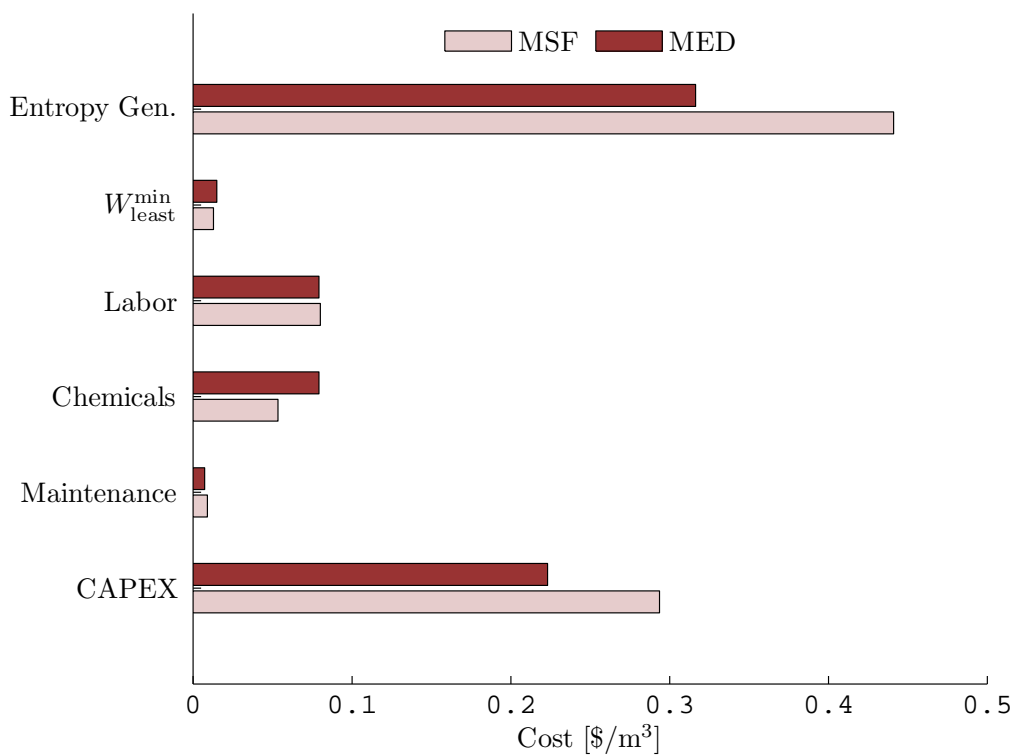

Figure 3. Breakdown of costs associated with the production of water using MSF and MED with entropy generation isolated.



In the next section, an energetic and economic model for a reverse osmosis system is presented and studied in greater detail than was possible based on the information available for the MSF and MED systems. By using an energetic model, specific sources of irreversibilities for the RO system are isolated.

4.2. Reverse Osmosis

Reverse osmosis is the most common form of desalination [20]. A representative flow path of a single stage RO plant with energy recovery is shown in Figure 4 [29]. A simple model based on the pressure differences throughout the system is used to evaluate the energetic requirements of this system [3]. In order to simplify the analysis of this system, thermal effects are neglected since they are of second order to pressure effects. Additionally, several approximations and design decisions are made.

Figure 4. A typical flow path for a single stage reverse osmosis system [3].

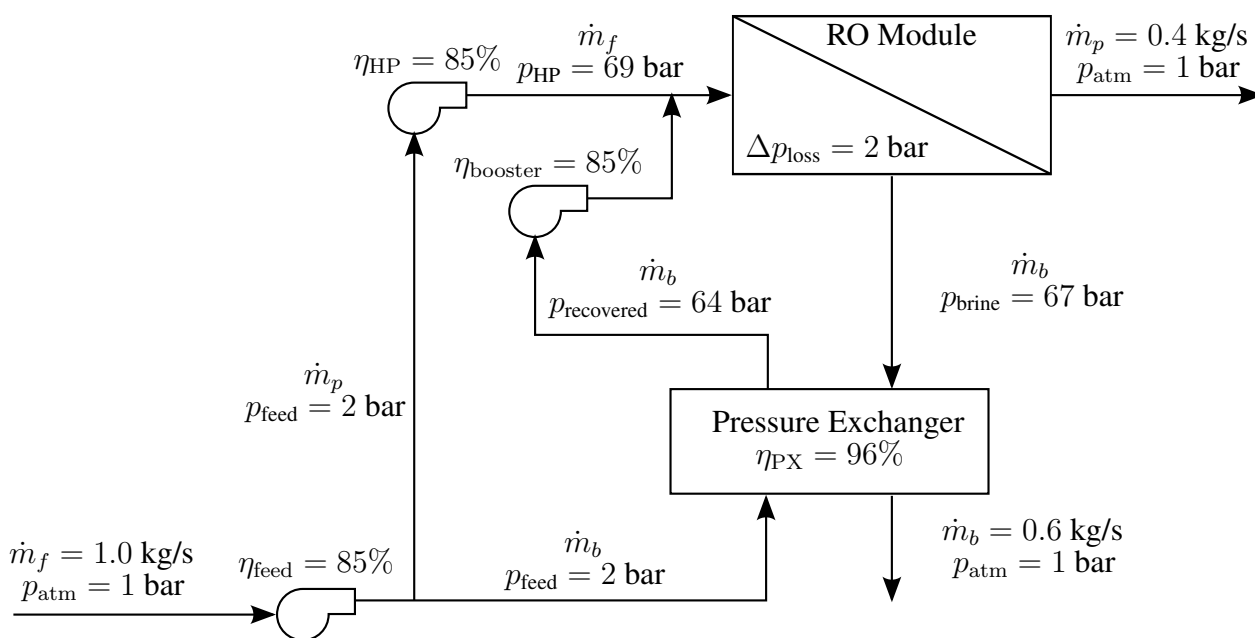

Feed seawater enters the system at ambient conditions (25 °C, 1 bar, 35 g/kg salinity). The product is pure H₂O (0 g/kg salinity) produced at a recovery ratio of 40%. In order to match flow rates in the pressure exchanger, 40% of the feed is pumped to 69 bar using a high pressure pump while the remaining 60% is pumped to the same pressure using a combination of a pressure exchanger driven by the rejected brine as well as a booster pump. All pumps are assumed to have isentropic efficiencies of 85%. The concentrated brine loses 2 bar of pressure through the RO module while the product leaves the module at 1 bar. Energy Recovery Inc. (ERI) [30] makes a direct contact pressure exchanger that features a single rotating part. The pressure exchanger pressurizes part of the feed using work produced through the depressurization of the brine in the rotor. Assuming that the expansion and compression processes are 98% efficient [3,30], the recovered pressure is calculated as follows:

$$P_{recovered} = P_{feed} + \eta_{expansion}\eta_{compression} \left(\frac{\rho_{feed}}{\rho_{brine}} \right) (P_{brine} - P_{atm}) \tag{27}$$

and the pressure exchanger efficiency is evaluated using ERI's definition [29]:

$$\eta_{\text{PX}} = \frac{\sum_{\text{out}} \text{Pressure} \times \text{Flow}}{\sum_{\text{in}} \text{Pressure} \times \text{Flow}} \quad (28)$$

Density of seawater is evaluated using standard seawater properties [27,28].

Mistry *et al.* [3] derived simple formulas based on the ideal gas and incompressible fluid models for the entropy generation through various mechanisms found in desalination processes. Entropy generated in the high pressure pump, booster pump, and the feed in the pressure exchanger is given by:

$$s_{\text{gen}}^{\text{pumping}} = c \ln \left[1 + \frac{v}{cT_1} (p_2 - p_1) \left(\frac{1}{\eta_p} - 1 \right) \right] \approx \frac{v}{T_1} (p_2 - p_1) \left(\frac{1}{\eta_p} - 1 \right) \quad (29)$$

where c is the specific heat, v is the specific volume, η_p is the isentropic efficiency of the pump, and states 1 and 2 correspond to the inlet and outlet, respectively. Similarly, entropy generated through the expansion of the pressurized brine in the pressure exchanger is given by:

$$s_{\text{gen}}^{\text{expansion,IF}} = c \ln \left[1 + \frac{v}{cT_1} (p_1 - p_2) (1 - \eta_e) \right] \approx \frac{v}{T_1} (p_1 - p_2) (1 - \eta_e) \quad (30)$$

where η_e is the isentropic efficiency of the expansion device.

Entropy generation in the RO module is a function of the change of both the mechanical and chemical states of seawater. In order to evaluate entropy generation, the change in entropy associated with all parts of the process path must be considered. Given that entropy is a state variable, the process can be decomposed into two sub-processes for the purpose of calculating the overall change of state. First, the high pressure seawater is isobarically and isothermally separated into two streams of different composition (note, in a real system, this would require a heat transfer process with the environment; however, thermal effects are neglected in this analysis). Second, the two streams are depressurized at constant salinity in order to account for the pressure drop associated with diffusion through the membrane (product, $\Delta p = 68$ bar) and that associated with hydraulic friction (brine, $\Delta p = 2$ bar).

Entropy change due to the separation process is evaluated as a function of temperature, pressure, and salinity of each of the process streams. For the model of separation considered here, the compositional change is taken at constant high pressure and temperature:

$$\Delta \dot{S}_{\text{composition}} = \dot{m}_p s_p(T_0, p_{\text{HP}}, y_p) + \dot{m}_c s_p(T_0, p_{\text{HP}}, y_p) - \dot{m}_f s_f(T_0, p_{\text{HP}}, y_f) \quad (31)$$

Standard seawater properties [27,28] are used for evaluating entropy. Even though this property package is independent of pressure, it may be used because seawater is nearly incompressible resulting in entropy being largely independent of p .

Mistry *et al.* [3] showed that entropy generation due to the irreversible depressurization of both the brine and product streams is given by:

$$s_{\text{gen}}^{\Delta p, \text{IF}} = c \ln \left[1 + \frac{v}{cT_1} (p_1 - p_2) \right] \approx \frac{v}{T_1} (p_1 - p_2) \quad (32)$$

The total entropy generated in the RO module is the sum of the entropy change due to compositional changes, Equation (31), and the entropy generated in the depressurization of the product and brine streams, Equation (32).

Entropy generated as a result of the discard of disequilibrium streams to the environment must also be considered. Thermal and chemical disequilibrium entropy generation can be evaluated using [3]:

$$\dot{S}_{gen}^{T \text{ disequilibrium}} = \dot{m}_i c_i \left[\ln \left(\frac{T_0}{T_i} \right) + \frac{T_i}{T_0} - 1 \right] \tag{33}$$

$$\dot{S}_{gen}^{\text{concentrate RDS} \rightarrow \text{TDS}} = - \frac{(\dot{m}_c + \dot{m}_{sw}^{\text{reservoir}})g_{out} - \dot{m}_c g_c - \dot{m}_{sw}^{\text{reservoir}} g_{sw}}{T_0} \tag{34}$$

Since thermal effects are neglected in this analysis, Equation (33) reduces to zero. The energy dissipated by pressure loss and pump inefficiency results in very small increases in the system temperature. As a result, the entropy generation associated with the transfer of this energy out of the system as heat (if any) through the very small temperature difference from the environment is negligible relative to the mechanical sources of entropy production.

Using Equations (27) and (29) to (32) and the denominator of Equation (9), the required energy input to the RO system, as well as the entropy generation within each component can be evaluated. The results of this model are provided in Table 2 and a discussion is provided by Mistry *et al.* [3].

Table 2. Contributions to the overall energy requirements of a reverse osmosis system, evaluated in terms of entropy generated within each component.

Sources of Energy Consumption	Entropy Generation [J/kg K]	Energy Contribution [kJ/kg]
W_{least}^{min}	-	2.71
RO Module	10.6	3.16
High pressure pump	3.87	1.15
Pressure exchanger	1.26	0.377
Booster pump	0.407	0.121
Feed pump	0.145	0.043
Chemical disequilibrium	3.08	0.918
Total:	19.4	8.48 (2.35 kWh/m ³)

A basic cost model based on the work of Bilton *et al.* [31,32] is used to generate an estimate of the total cost of producing water. The total annualized cost (TOTEX) is equal to the sum of the capital expenses (CAPEX) and the operating expenses (OPEX) [6,12,33]:

$$A_{TOTEX} = A_{CAPEX} + A_{OPEX} \tag{35}$$

It is typically more convenient to refer to the unit cost of producing water than the annual cost of the system. Cost per unit water can be evaluated by dividing the annualized cost by the yearly water production:

$$C_w = \frac{A_{TOTEX}}{\dot{V}_w} \tag{36}$$

Yearly water production is equal to the daily capacity times the number of days in a year times the availability factor (AF):

$$\dot{V}_w = 365AF\dot{V}_{capacity} \tag{37}$$

The CAPEX for a standard RO plant is subdivided into the cost of the RO system and the infrastructure:

$$C_{\text{CAPEX}} = C_{\text{infrastructure}} + C_{\text{RO}} \quad (38)$$

The RO system is composed of the RO components, pre-treatment, post-treatment and piping:

$$C_{\text{RO}} = C_{\text{pre}} + C_{\text{RO comp}} + C_{\text{pipe}} + C_{\text{post}} \quad (39)$$

The RO components include membranes, pressure vessels, pumps, motors, energy recovery devices (ERD), and connections:

$$C_{\text{RO comp}} = C_{\text{membranes}} + C_{\text{pressure vessels}} + C_{\text{pumps}} + C_{\text{motors}} + C_{\text{ERD}} + C_{\text{connections}} \quad (40)$$

Costs for the components are given in Table 3. The booster pump and motor are approximated as costing one third the cost of the high pressure pump and motor [34]. Total component costs are based on a system size of $\dot{V}_{\text{capacity}} = 10,000 \text{ m}^3/\text{d}$.

Table 3. Cost of components required for a reverse osmosis system. The number required is determined for a $10,000 \text{ m}^3/\text{d}$ system, based on the volumetric flow rate capacity of each device. Cost of replacement is considered separately in Table 5. ERD, energy recovery device.

Component	Cost [\$]	Capacity [m ³ /d]	Number [-]	Total Cost [\$]
Membrane [35,36]	550	25	1,000	550,000
Pressure vessel (6 membranes) [37,38]	1,945	-	167	325,000
High Pressure pump [39,40]	50,000	720	14	700,000
Booster pump [34]	17,000	1,000	15	255,000
High pressure motor [41]	12,000	-	14	168,000
Booster motor [34]	4,000	-	15	60,000
ERD [34,36,42]	24,000	1,000	15	360,000
Total ($C_{\text{RO comp}}$)				2,420,000

For typical RO systems, both pre- and post-treatment are needed. Pre-treatment is used to provide basic filtration and treatment to remove large debris, biological contaminants, and other suspended solids that might damage the RO membranes [43]. Similarly, post-treatment is needed to add essential minerals back to the water so that the water can safely be added to municipal pipelines [43]. In order to simplify the analysis in this model, both the pre- and post-treatment costs are assumed to be proportional to the total cost of the RO components. Post-treatment costs can also include the cost of storage.

$$C_{\text{pre}} = \phi_{\text{pre}} C_{\text{RO comp}} \quad (41)$$

$$C_{\text{post}} = \phi_{\text{post}} C_{\text{RO comp}} + C_{\text{storage}} \quad (42)$$

Values for ϕ_{pre} and ϕ_{post} are taken to be 0.35 and 0.03, respectively [44]. For large municipal-scale systems, it is assumed that the water is fed directly to the water grid and that storage costs may be neglected.

In addition to the cost of the RO plant, there are a number of costs associated with infrastructure. These costs include: land, intake and brine dispersion systems, connections to the grid, installation and construction, etc. As with the pre- and post-treatments, for simplicity, it is assumed that these costs scale linearly with the cost of the RO plant:

$$C_{infrastructure} = \phi_{infrastructure} C_{RO} \tag{43}$$

where $\phi_{infrastructure}$ is taken to be 1.71 [44]. Given that infrastructure costs are a significant fraction of the total cost of the system, accurate cost calculations are dependent on the value of $\phi_{infrastructure}$; therefore, this value should always be refined based on the specific plant being considered.

Now that all of the CAPEX are accounted for, they must be converted to annualized costs. This is done by multiplying the CAPEX by an amortization factor, given by:

$$A_{CAPEX} = \frac{i(1+i)^n}{(1+i)^n - 1} C_{CAPEX} \tag{44}$$

where i is the annual interest rate and n is the expected plant life in years [45]. For this analysis, a 7.5% interest rate for a plant with a 25 year expected lifetime is assumed [5]. All capital expenses are summarized in Table 4. Note that replacement is considered separately in Table 5.

Table 4. Summary of capital expenses for a representative reverse osmosis system.

Capital Expenses	Scaling Factor	Cost [\$]
RO Components ($C_{RO\ comp}$)		2,420,000
Piping and connections [12]	$\phi_{pipe} = 0.66 \times C_{RO\ comp}$	1,600,000
Pre-treatment [44]	$\phi_{pre} = 0.35 \times C_{RO\ comp}$	846,000
Post-treatment [44]	$\phi_{post} = 0.03 \times C_{RO\ comp}$	72,500
Total RO (C_{RO})		4,930,000
Infrastructure [44]	$\phi_{infrastructure} = 1.71 \times C_{RO}$	8,430,000
Total Plant (C_{CAPEX})		13,400,000
Annualized CAPEX	$i = 7.5\%, n = 25\text{ years}$	1,200,000
Per m ³		0.346

Total OPEX is composed of the costs of labor, chemicals, power, and replacements. Labor, chemicals, and power all scale with the yearly water production, \dot{V}_w . If it is assumed the system operates 95% of the time (AF = 0.95), then the costs of labor, chemicals, and power are:

$$A_{labor} = \gamma_{labor} \dot{V}_w \tag{45}$$

$$A_{chemicals} = \gamma_{chemicals} \dot{V}_w \tag{46}$$

$$A_{electricity} = \gamma_{electricity} W_{sep} \dot{V}_w \tag{47}$$

where γ_{labor} is the specific operating cost of labor, $\gamma_{\text{chemicals}}$ is the average cost of chemicals, $\gamma_{\text{electricity}}$ is the cost of electricity, and \dot{W}_{sep} is the electricity requirements for the RO system. The electrical requirements for pre- and post-treatment are neglected in this study. For this analysis, $\gamma_{\text{labor}} = \$0.05/\text{m}^3$ [45,46] and $\gamma_{\text{chemicals}} = \$0.033/\text{m}^3$ [45]. The cost of electricity varies widely depending on location. While the average price for electricity for industrial use in the US is $\$0.0652/\text{kWh}$, a price more typical of the population-dense areas of the East and West Coasts is closer to $\$0.11/\text{kWh}$ [47]. Therefore, the cost of electricity is taken to be $\gamma_{\text{electricity}} = \$0.11/\text{kWh}$, while \dot{W}_{sep} is evaluated using the RO model described above and summarized in Table 2 [3].

Part of the operating expense is the cost of replacing parts as they reach the end of their product lifetime. Given that many components will not last the entire lifetime of the overall plant, it is important to properly account for replacement of expensive components. The annualized cost of replacement is given by:

$$A_R = C_{\text{membrane}}R_{R,\text{membrane}} + C_{\text{pump}}R_{R,\text{pump}} + C_{\text{motor}}R_{R,\text{motor}} + C_{\text{ERD}}R_{R,\text{ERD}} + C_{\text{pre}}R_{R,\text{pre}} + C_{\text{post}}R_{R,\text{post}} \tag{48}$$

where R_R is the annual replacement rate. Values of R_R along with the corresponding component costs are provided in Table 5. All OPEX are summarized in Table 6.

Table 5. Replacement rate for various reverse osmosis components.

Component	R_R	C_i [\$]	Total [\$]
Membrane	0.2	550,000	110,000
Pumps	0.1	955,000	95,500
Motors	0.1	228,000	22,800
ERD	0.1	360,000	36,000
Pre-treatment	0.1	846,235	84,600
Post-treatment	0.1	72,534	7,250
Total Replacement Cost (A_R)			356,000

Table 6. Summary of operating expenses for a representative reverse osmosis system. OPEX, operating expenses.

Operating Expenses	Scaling Factor	Cost [\$]
Labor [45,46]	$\gamma_{\text{labor}} = 0.05 \times \dot{V}_w$	173,000
Chemicals [45]	$\gamma_{\text{chemicals}} = 0.033 \times \dot{V}_w$	114,000
Electricity [47]	$\gamma_{\text{electricity}} = 0.11 \times \dot{W}_{\text{sep}} \dot{V}_w$	899,000
Replacement		356,000
Total Annual OPEX		1,540,000
Per m^3		0.445

Combining all of the CAPEX and OPEX, an estimate of the cost of water using the RO system shown in Figure 4 can be evaluated. For a system that produces 10,000 m³/d, the cost of water is estimated to be \$0.791/m³. A bar chart showing the relative contributions to the cost of water production is given in Figure 5. The economic Second Law efficiency of this system can now be evaluated using Equation (23). Using Equation (2) and a standard seawater property package [27,28], the minimum least work of separation for the feed seawater is 2.71 kJ/kg (0.75 kWh_e/m³). Therefore:

$$\eta_{II,s} = \frac{c_e \dot{W}_{\text{least}}^{\text{min}}}{\text{total cost}} = \frac{\gamma_{\text{electricity}} W_{\text{least}}^{\text{min}}}{C_w} = \frac{(\$0.11/\text{kWh})(0.75 \text{ kWh}/\text{m}^3)}{\$0.791/\text{m}^3} = 10\% \quad (49)$$

Compare this to the value of the Second Law efficiency:

$$\eta_{II} = \frac{\dot{W}_{\text{least}}^{\text{min}}}{\dot{W}_{\text{sep}}} = \frac{0.75}{2.35} = 32\% \quad (50)$$

Figure 5. Breakdown of costs associated with the production of water using reverse osmosis.

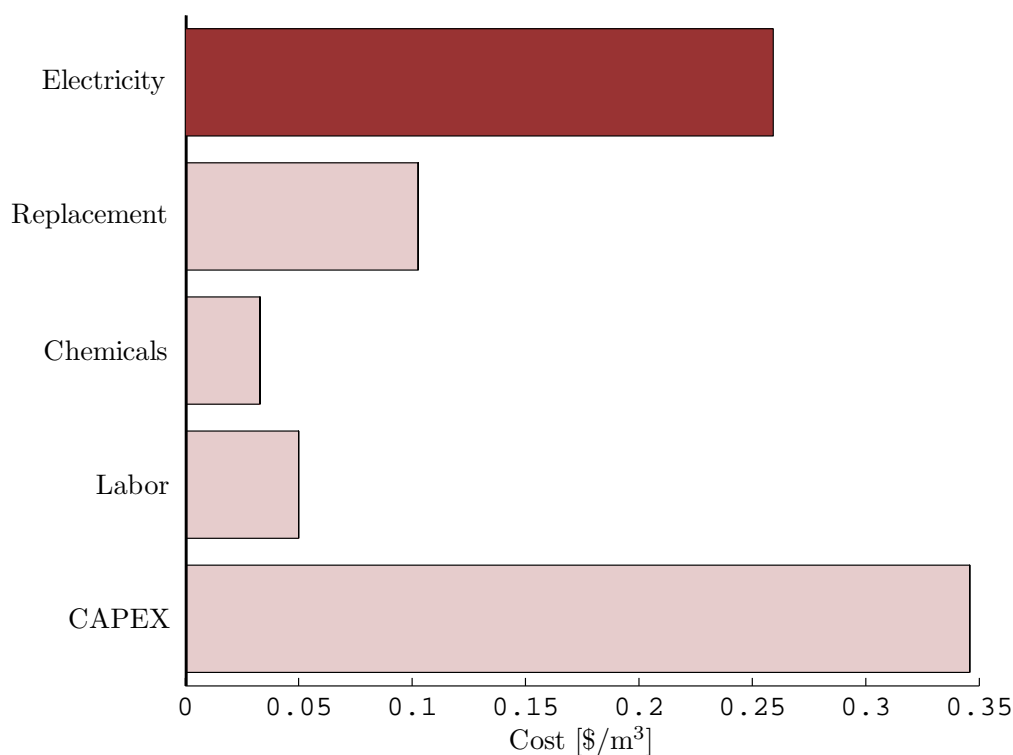

As shown in Figure 5, costs associated with capital expenses and replacement of parts are the most significant contributors to the overall cost of this particular RO system. However, the cost of energy is also significant and represents about 34% of the overall cost. The overall energy cost can be further subdivided into costs associated with the thermodynamic process of separation ($\dot{W}_{\text{least}}^{\text{min}}$) and those associated with irreversibilities ($T_0 \dot{S}_{\text{gen}}$), as shown in Table 2. Scaling the various energy components using $\gamma_{\text{electricity}}$, Figure 5 is redrawn in terms of each of the sources of irreversibilities (Figure 6).

Figure 6 shows that the costs associated with thermodynamic irreversibility are on the same order as the costs associated with replacement costs and the minimum least energy of separation. Irreversibilities

associated with losses in the RO module, the high pressure pump and chemical disequilibrium of the brine stream are particularly pronounced. Chemical disequilibrium of the brine is only important in systems in which both the recovery ratio and the Second Law efficiency are high [3]. Since CAPEX is the greatest source of cost by a wide margin, the system and hardware selection is the most crucial part of the design process. Similarly, replacement cost is a significant contributor to the total cost. This can be reduced by selecting parts with longer lifetimes. In terms of irreversibilities, the energy costs associated with losses in the RO module, the high pressure pump and the chemical energy in the brine are most significant. Losses in the RO module can be reduced through staging and/or batch processing [48]. Losses in the high pressure (HP) pump can be reduced through the use of higher performance pumps or enhanced energy recovery [36,49]. Unfortunately, the irreversibilities associated with the chemical disequilibrium of the concentrate cannot be reduced unless the recovery ratio of the process is reduced.

Figure 6. Breakdown of costs associated with the production of water using reverse osmosis with the costs of entropy generation isolated by component.

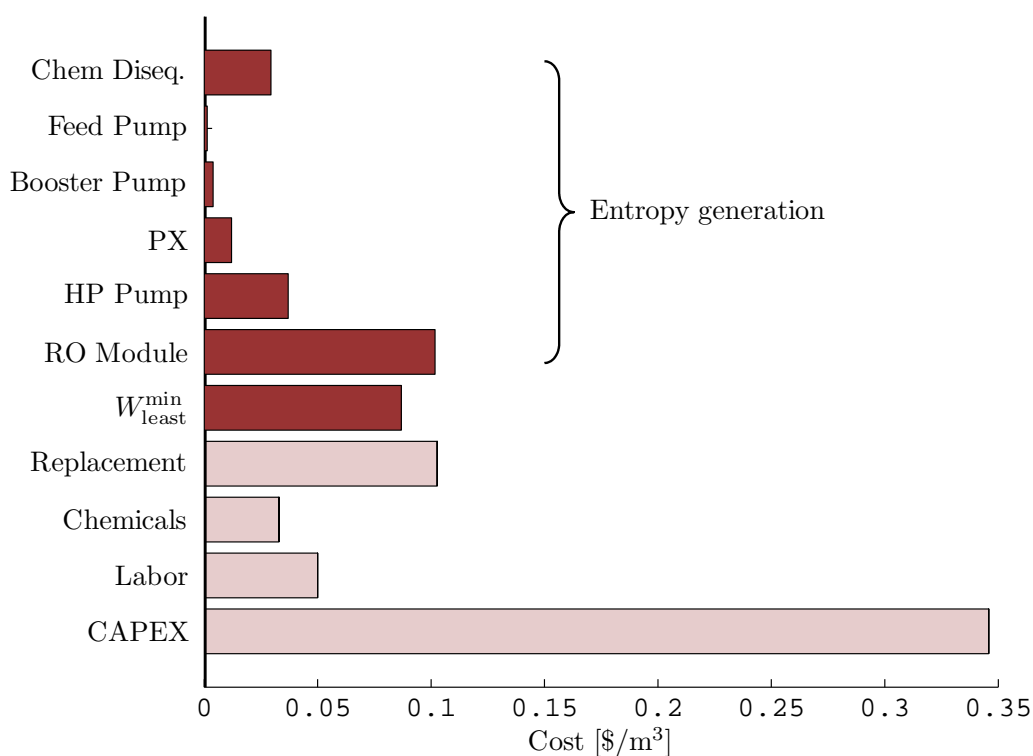

Through this analysis, one can clearly see all of the costs associated with the reverse osmosis process and can easily compare the cost of irreversibility in each of the major components. For the particular system seen here, it is clear that CAPEX, and not irreversibility, is the dominant contributor to the total cost of water production.

4.3. Membrane Distillation

Direct contact membrane distillation (DCMD) is a membrane-based thermal distillation process [50] that can be driven using solar energy. Therefore, it provides a good example for considering the

evaluation of $\eta_{II,s}$ for systems with so-called “free” energy input. In DCMD, a hydrophobic microporous membrane is used to separate the feed and product streams. The temperature difference between a heated feed stream and the cooled fresh water stream induces a vapor pressure difference that drives evaporation through the pores. The vapor diffusion transport process is characterized by the membrane distillation coefficient, B , a parameter that is used to measure the pore’s diffusion resistance. Experimental DCMD systems have successfully produced fresh water at a small scale ($0.1 \text{ m}^3/\text{d}$) [51–55].

A transport process model for DCMD implemented by Summers *et al.* [55], Saffarini *et al.* [56] is used in this study. A schematic diagram of the system considered is shown in Figure 7. Key module geometry and constants are shown. The model is based on validated models by Bui *et al.* [57] and Lee *et al.* [54] and was also used by Mistry *et al.* [3] in a previous study. The present calculations are performed for a flat-sheet membrane configuration (Bui *et al.* [57] relied on a hollow-fiber membrane configuration) using membrane geometry and operating conditions typical of pilot-sized plants found in the literature [58,59]. Feed seawater (27°C , 35 g/kg total dissolved solids) enters the system at a mass flow rate of 1 kg/s . The feed is heated to 85°C using a 90°C source. In order to balance the mass flow rates through the membrane, the permeate side contains fresh water, also at a flow rate of 1 kg/s . The recovery ratio for this system and operating conditions is 4.4% . A liquid-liquid heat exchanger with a 3 K terminal temperature difference is used to regenerate heat. All pressure drops in the system other than that through the membrane are considered negligible. The pressure drop through the thin channel in the membrane module was found to be the dominant pressure drop in the system and was the basis for calculating the entropy generation due to pumping power. As with the RO model, standard seawater properties are used in this calculation [27,28].

Figure 7. Flow path for a basic direct contact membrane distillation system [3].

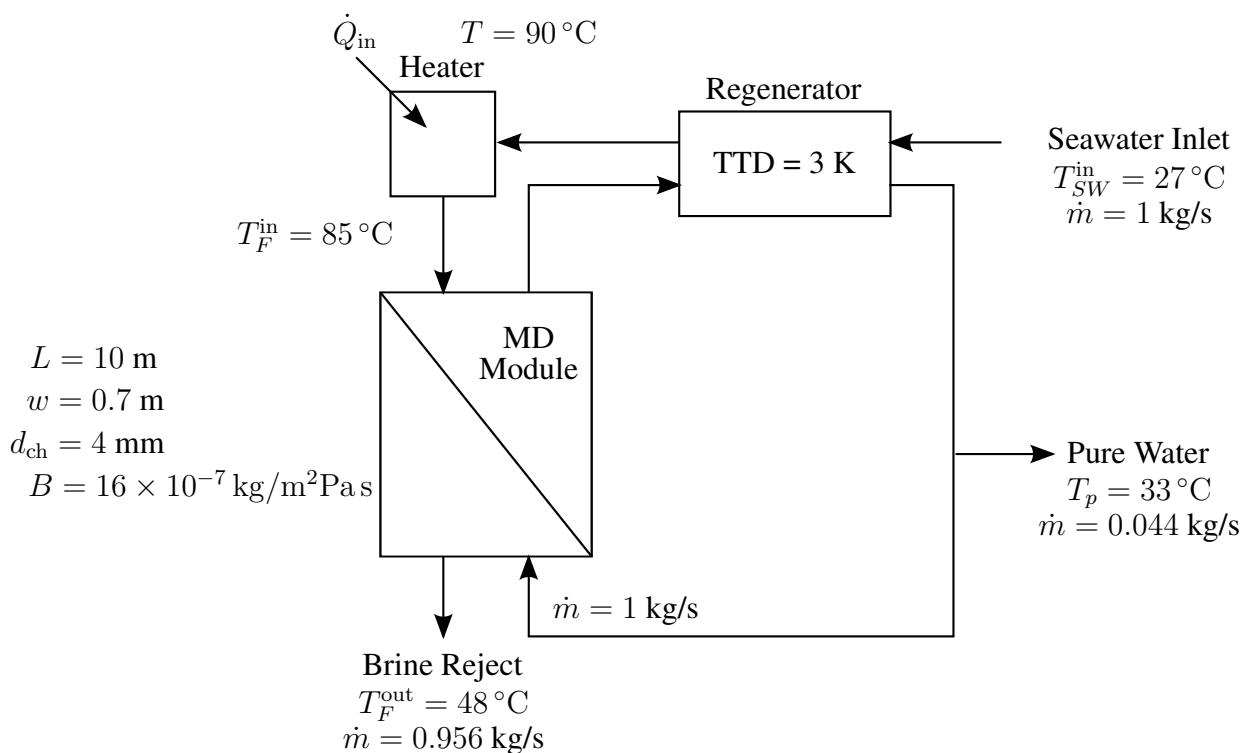

Entropy generation in each component was evaluated using control volume analysis [3], while entropy generation due to the temperature disequilibrium of the product and concentrate is evaluated using Equation (33). Modeling results are tabulated in Table 7.

Table 7. Contributions to the overall energy requirements of a direct contact membrane distillation system, evaluated in terms of entropy generated within each component.

Sources of energy consumption	Entropy generation [J/kg K]	Energy contribution [kJ/kg]
$Q_{\text{least}}^{\text{min}}$	-	15.7
Module	319	552
Heater	243	421
Regenerator	151	262
Temperature disequilibrium	212	366
Total:	925	1620

A cost model similar to that for the RO system is used for the DCMD system. Saffarini *et al.* [56] develop and describe a DCMD cost model in detail and the major cost figures are summarized herein. The total annualized cost of water can be expressed as the sum of the capital and operating expenses, as per Equation (35). The capital expenses can be split into several parts: membrane/module costs, solar energy costs (photovoltaic modules and solar thermal collectors), all other miscellaneous costs including piping, installation, and so on.

$$C_{\text{CAPEX}} = C_{\text{membranes}} + C_{\text{PV}} + C_{\text{heat}} + C_{\text{HEX}} + C_{\text{pump}} + C_{\text{fixed}} \quad (51)$$

Membranes, including the module, cost \$350/m² of membrane area [60]. Solar heaters are used to provide the necessary heat input and are estimated at \$160/m² of collector area [43,61]. Photovoltaic (PV) panels are used for supplying electrical energy to the pumps and other electronics as needed. Note that since this analysis is for an experimental system, the electrical requirements for pumping water to the system are negligible and left out of the present calculation. PV costs are approximately \$4/W [52]. Heat exchangers and pumps cost \$750 and \$700, respectively [61]. The remaining fixed capital costs include piping, batteries, monitoring equipment, and installation and may be estimated as \$5550 [56,61]. A summary of all of the capital expenses is provided in Table 8.

Once all capital costs are evaluated, they are converted to annualized costs using an amortization factor:

$$A_{\text{CAPEX}} = \left(\frac{i(1+i)^n}{(1+i)^n - 1} \right) C_{\text{CAPEX}} \quad (52)$$

For this analysis, an 8% interest rate for a plant with a 20 year expected lifetime is assumed [56].

Operating costs for the DCMD system are assumed to consist of only maintenance and membrane replacement. No chemical pretreatment is required for most MD systems [56], and it is assumed that the required labor for this small-scale system is provided by the owners. Therefore, both can be neglected.

Maintenance is approximated as 0.5% of CAPEX [60], and it is estimated that 12% of the membranes are replaced each year [61]. Operating costs are summarized in Table 9.

Table 8. Summary of capital expenses for a representative direct contact membrane distillation. PV, photovoltaic.

Capital Costs	Specific Cost	Scaling	Total Cost [\$]
Membranes [60]	\$350/m ²	7 m ²	2,450
Heat exchanger [61]	\$750/unit	1 unit	750
Pump [61]	\$700/unit	2 unit	1,400
Fixed costs [56,61]	\$5,550	-	5,550
Solar heaters [43,61]	\$160/m ²	200 m ²	32,000
PV [52]	\$4/W	33 W	131
Total			42,300
Amortized			4,310
Per m ³			9.77

Table 9. Summary of operating expenses for a representative direct contact membrane distillation.

Operating Expenses	Scaling Factor	Times	Total Cost [\$]
Maintenance	0.005	42,300	212
Membrane replacement	0.12	2,450	294
Total			506
Per m ³			1.15

Combining the CAPEX and OPEX as shown in Tables 8 and 9, the total annualized cost of water is shown to be \$10.90/m³. A breakdown of all of the CAPEX and OPEX for the DCMD system is shown in Figure 8

In order to calculate $\eta_{II,\$}$, the cost of heating the feed in the DCMD system must be determined. Since the CAPEX of the solar heaters is known, this is easily calculated by considering the amortized cost of the solar heater divided by the amount of heating required by the system per kilogram of product produced. That is:

$$c_h = \frac{C_{heat} \left(\frac{i(1+i)^n}{(1+i)^n - 1} \right)}{Q_{solar}} = \frac{\$32,000 \cdot 0.1119}{85 \text{ kW} \cdot 3600 \cdot 8 \cdot 365 \cdot 0.96} = \$0.015/\text{kWh}_t \quad (53)$$

This value represents the amortized cost of the solar heaters per unit thermal energy provided. The minimum least heat of separation for 35 g/kg of seawater at 27 °C is 15.7 kJ/kg (4.37 kWh/m³). Therefore, $\eta_{II,\$}$ is evaluated as:

$$\eta_{II,\$} = \frac{c_h \dot{Q}_{least}^{\min}}{\text{Total Cost}} = \frac{(\$0.015/\text{kWh})(4.37 \text{ kWh/m}^3)}{\$10.90/\text{m}^3} = 0.60\% \quad (54)$$

Despite the fact that the cost of solar-thermal energy is very low, this DCMD system has a very poor $\eta_{II,s}$ value since the system requires substantially more thermal energy than $\dot{Q}_{\text{least}}^{\text{min}}$. Additionally, electrical energy is required to overcome pressure losses within the system. This is characterized by a low η_{II} value as well:

$$\eta_{II} = \frac{\dot{Q}_{\text{least}}^{\text{min}}}{\dot{Q}_{\text{sep}} + \dot{W}_{\text{sep}}/\eta_{\text{Carnot}}} = 1\% \quad (55)$$

Figure 8. Breakdown of costs associated with the production of water using direct contact membrane distillation.

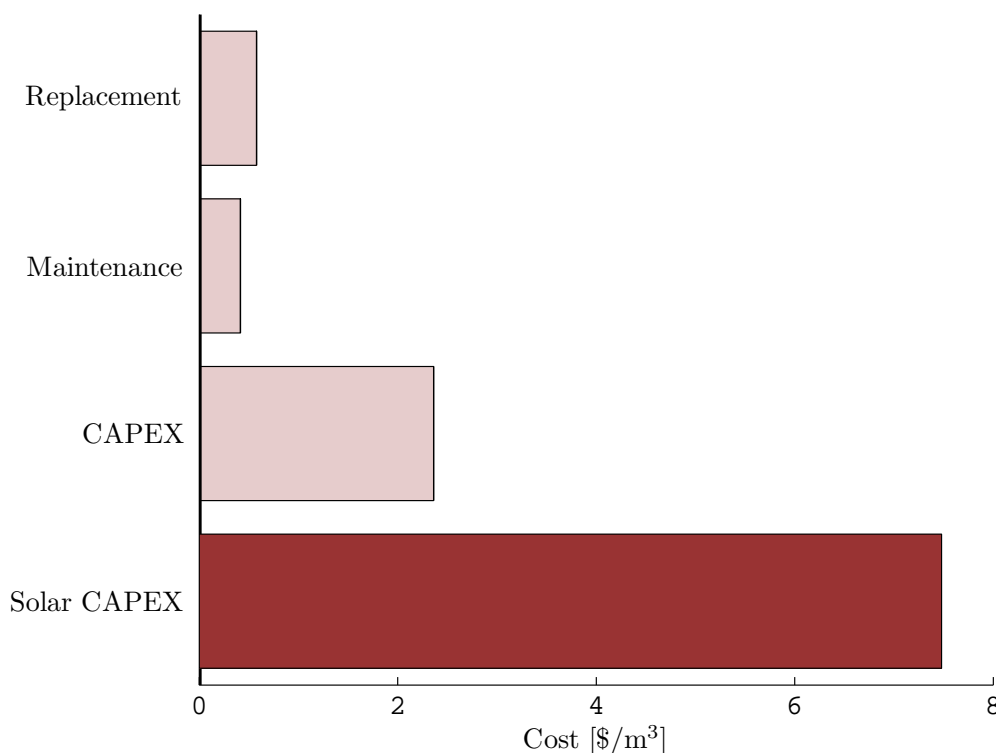

Since the cost of energy in the solar powered DCMD system is captured by the capital expense associated with building and installing the solar heaters, it is useful to separate that cost into its component parts. Namely, it can be split into the cost of the minimum least heat of separation and all of the entropy generation in the various components in the system and due to chemical and thermal disequilibrium of the discharged streams. The solar heater costs are split and compared to all the other costs in Figure 9. It is clear that the costs associated with entropy generation in each component is of the same order of magnitude as the entire capital expense of the rest of the DCMD system. In particular, losses in the module are the single greatest source of cost for this system.

Figure 9. Breakdown of costs associated with the production of water using direct contact membrane distillation with the cost of entropy generation expanded.

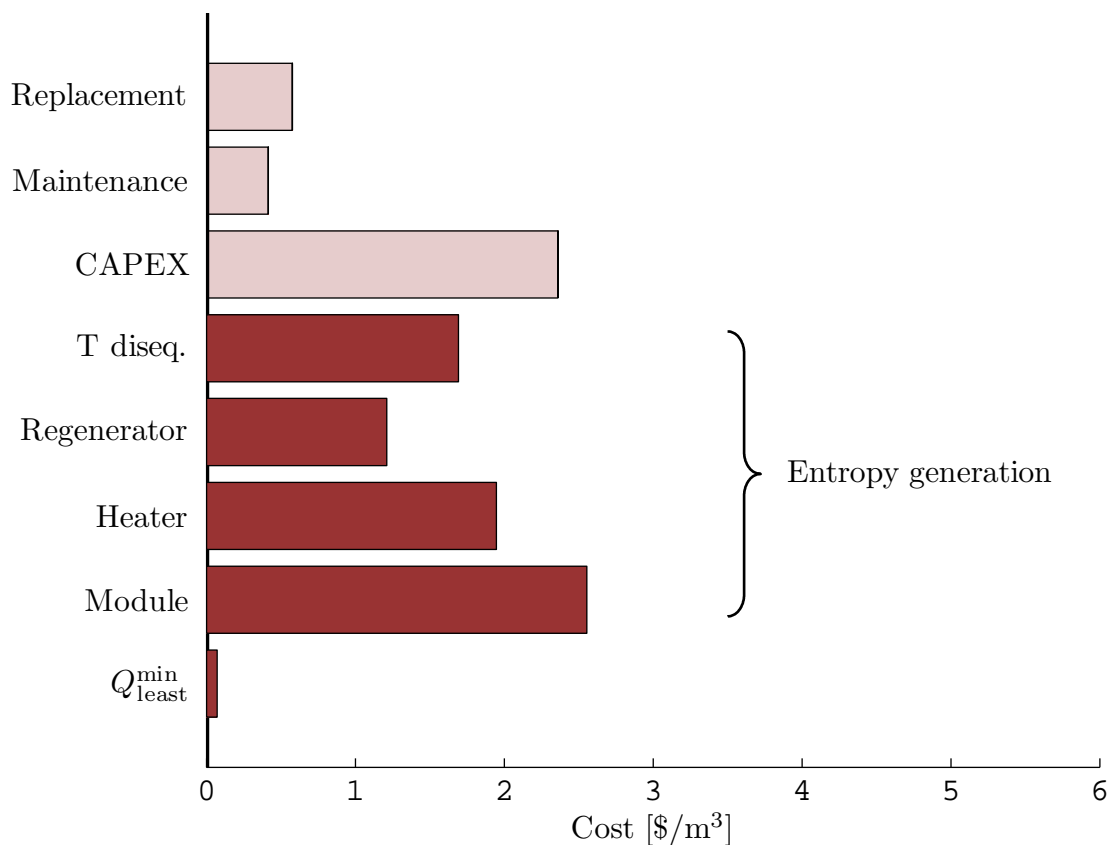

From this example, it is evident that freely available energy, such as solar power, is not truly free. The capital expense required to harvest the solar thermal energy is significant and, in some cases, can be the majority of a system cost.

5. Conclusions

In this paper, the following conclusions have been reached:

- (1) An economics-based Second Law efficiency is defined in analogy to the exergetics-based Second Law efficiency. It is defined as the ratio of the cost of the minimum least (primary) energy of separation to the actual cost of separation. The actual cost should include all factors, including all CAPEX and OPEX.
- (2) The energy costs can be broken up into the cost of the minimum least work of separation plus the sum of the costs for all of the irreversibilities (exergy destruction). When the energy costs are expressed in terms of the cost of exergy destroyed, all other costs (CAPEX, labor, replacement, *etc.*) can be likened to exergetic irreversibilities and viewed as “losses.”

- (3) For energies typically considered to be free (*e.g.*, solar energy and wind energy), the additional capital expense for the infrastructure required to harvest the energy must be included in the cost function.
- (4) By comparing the cost of thermodynamic irreversibilities to all other system costs, it is easy to identify what aspects of a system design should be optimized. For cases where energy costs, as a result of irreversibilities, dominate the total cost of production, attention should be paid to improving the system thermodynamics. In cases where energy costs are not the primary contributor to overall cost, the non-thermodynamic parameters should be investigated for possible sources of cost reduction.

Acknowledgements

The authors would like to thank the King Fahd University of Petroleum and Minerals in Dhahran, Saudi Arabia, for funding the research reported in this paper through the Center for Clean Water and Clean Energy at MIT and KFUPM under project number R13-CW-10.

Conflict of Interest

The authors declare no conflict of interest.

References

1. Shannon, M.A.; Bohn, P.W.; Elimelech, M.; Georgiadis, J.G.; Marinas, B.J.; Mayes, A.M. Science and technology for water purification in the coming decades. *Nature* **2008**, *452*, 301–310.
2. Semiat, R. Energy issues in desalination processes. *Environ. Sci. Tech.* **2008**, *42*, 8193–8201.
3. Mistry, K.H.; McGovern, R.K.; Thiel, G.P.; Summers, E.K.; Zubair, S.M.; Lienhard, J.H., V. Entropy generation analysis of desalination technologies. *Entropy* **2011**, *13*, 1829–1864.
4. Mistry, K.H.; Lienhard, J.H., V. Generalized Least Energy of Separation for Desalination and Other Chemical Separation Processes. *Entropy* **2013**, *15*, 2046–2080.
5. Spiegler, K.S.; El-Sayed, Y.M. *A Desalination Primer: Introductory Book for Students and Newcomers to Desalination*; Balaban Desalination Publications: Santa Maria Imbaro, Italy, 1994.
6. Sommariva, C. *Desalination and Advanced Water Treatment: Economics and Financing*; Balaban Desalination Publications: Hopkinton, MA, USA, 2010.
7. Tribus, M.; Pezier, J.P. Concerning the economic value of experimentation in the design of desalting plants. *Desalination* **1970**, *8*, 311–349.
8. Evans, R.B.; Crellin, G.L.; Tribus, M. Thermoeconomic considerations of sea water demineralization. In *Principles of Desalination*, 2nd ed.; Speigler, K., Laird, A.D.K., Eds.; Academic Press: New York, NY, USA, 1980; Chapter 1, pp. 1–54.
9. Spiegler, K. Thermodynamic analysis. *Desalination* **1983**, *44*, 3–16.
10. London, A. Economics and the second law: An engineering view and methodology. *Int. J. Heat Mass Transf.* **1982**, *25*, 743–751.

11. El-Sayed, Y.M. Advances in the methodologies of optimal thermal design. *Desalination* **1993**, *92*, 79–101.
12. Bejan, A.; Tsatsaronis, G.; Moran, M. *Thermal Design & Optimization*; John Wiley & Sons, Inc.: New York, NY, USA, 1996.
13. Sayyaadi, H.; Saffari, A.; Mahmoodian, A. Various approaches in optimization of multi effects distillation desalination systems using a hybrid meta-heuristic optimization tool. *Desalination* **2010**, *254*, 138–148.
14. Bejan, A. *Advanced Engineering Thermodynamics*, 3rd ed.; John Wiley & Sons, Inc.: Hoboken, NJ, USA, 2006.
15. Mistry, K.H.; Lienhard, J.H., V. Effect of nonideal solution behavior on desalination of a sodium chloride (NaCl) solution and comparison to seawater. In Proceedings of ASME 2012 International Mechanical Engineering Congress & Exposition, Houston, TX, USA, 9–15 November 2012; Number IMECE2012-88261.
16. Mistry, K.H.; Lienhard, J.H., V. Effect of nonideal solution behavior on desalination of a sodium chloride (NaCl) solution and comparison to seawater. *J. Energy Resour. Tech.* **2013**, accepted for publication.
17. Mistry, K.H.; Hunter, H.A.; Lienhard, J.H., V. Effect of composition and nonideal solution behavior on desalination calculations for mixed electrolyte solutions with comparison to seawater. *Desalination* **2013**, *318*, 34–47.
18. Moran, M.J. *Availability Analysis: A Guide to Efficient Energy Use*, corrected ed.; ASME Press: New York, NY, USA, 1989.
19. El-Sayed, Y.M.; Silver, R.S. Fundamentals of distillation. In *Principles of Desalination*, 2nd ed.; Speigler, K., Laird, A.D.K., Eds.; Academic Press: New York, NY, USA, 1980; Chapter 2, pp. 55–109.
20. Pankratz, T. *IDA Desalination Yearbook 2012–2013*; Media Analytics Ltc: Oxford, UK, 2013.
21. Mistry, K.H.; Antar, M.A.; Lienhard, J.H., V. An improved model for multiple effect distillation. *Desalin. Water Treat.* **2013**, *51*, 807–821.
22. Plappally, A.K.; Lienhard, J.H., V. Costs for water supply, treatment, end-use and reclamation. *Desalin. Water Treat.* **2013**, *51*, 200–232.
23. Plappally, A.K.; Lienhard, J.H., V. Energy requirements for water production, treatment, end use, reclamation, and disposal. *Renew. Sustain. Energy Rev.* **2012**, *16*, 4818–4848.
24. Gude, V.G.; Nirmalakhandan, N.; Deng, S. Renewable and sustainable approaches for desalination. *Renew. Sustain. Energy Rev.* **2010**, *14*, 2641–2654.
25. Mezher, T.; Fath, H.; Abbas, Z.; Khaled, A. Techno-economic assessment and environmental impacts of desalination technologies. *Desalination* **2011**, *266*, 263–273.
26. Committee on Advancing Desalination Technology, National Research Council. *Desalination: A National Perspective*; The National Academies Press: Washington, D.C., USA, 2008.
27. Sharqawy, M.H.; Lienhard, J.H., V; Zubair, S.M. Thermophysical properties of seawater: A review of existing correlations and data. *Desalin. Water Treat.* **2010**, *16*, 354–380.
28. Sharqawy, M.H.; Lienhard, J.H., V; Zubair, S.M. Thermophysical properties of seawater. Available online: <http://web.mit.edu/seawater/> (accessed on 17 July 2012).

29. Energy Recovery Inc. ERI Power Model. Available online: <http://www.energyrecovery.com/index.cfm/0/0/56-Power-Model.html/> (accessed on 1 June 2011).
30. Energy Recovery Inc. Technology Overview. Available online: <http://www.energyrecovery.com/index.cfm/0/0/33-Overview.html/> (accessed on 1 June 2011).
31. Bilton, A.M.; Wiesman, R.; Arif, A.; Zubair, S.M.; Dubowsky, S. On the feasibility of community-scale photovoltaic-powered reverse osmosis desalination systems for remote locations. *Renew. Energy* **2011**, *36*, 3246–3256.
32. Bilton, A.M. A Modular Design Architecture for Application to Community-Scale Photovoltaic-Powered Reverse Osmosis Systems. PhD thesis, Massachusetts Institute of Technology, Cambridge, MA, USA, 2013.
33. Peters, M.S.; Timmerhaus, K.D.; West, R.E. *Plant Design and Economics for Chemical Engineers*; McGraw Hill: New York, NY, USA 2003.
34. Stover, R.L. Desalitech Ltd, Boston, MA, USA. Personal Communication, 2013.
35. The Dow Chemical Company. DOW FILMTEC Membranes: SW30XHR-440i Seawater Reverse Osmosis Element with iLEC Interlocking Endcaps. Available online: http://www.dowwaterandprocess.com/products/membranes/sw30xhr_440i.htm/ (accessed on 17 April 2013)
36. Huehmer, R.; Alt, S.; Lozier, J.; Kupp, A.; Nading, T.; Egrican, K.; Emerson, B. *Evaluation and Optimization of Emerging and Existing Energy Recovery Devices for Desalination and Wastewater Membrane Treatment Plants*. Technical Report, CH2M HILL; WaterReuse Research Foundation: Alexandria, VA, USA, 2013.
37. Pentair Codeline. 8" Side Entry: 80S Series Membrane Housings. Available online: http://www.codeline.com/products/80S_side_entry.html/ (accessed on 17 April 2013).
38. AtlanticRO. Reverse Osmosis Membranes and Pressure Vessels. Available online: <http://www.atlanticro.com/Code.pdf> (accessed on 17 April 2013).
39. Big Brand Water Filter, Inc. Danfoss APP30. Available online: <http://www.bigbrandwater.com/danfoss25.html/> (accessed on 17 April 2013).
40. Danfoss. RO Solutions Brochure. Available online: http://www.danfoss.com/NR/rdonlyres/A2F103E1-CC9E-4BCD-BB4B-8E47F204B49C/0/521B1191_ROImagebrochure_USSize_web.pdf (accessed on 7 April 2013).
41. Baldor: A Member of the ABB Group. 501 Stock Product Catalog: IEC Frame Motors. Available online: <http://www.baldor.com/support/501catalog.asp/> (accessed on 7 April 2013).
42. Energy Recovery Inc. PX Pressure Exchanger Devices. Available online: <http://www.energyrecovery.com/px-pressure-exchanger-devices/> (accessed on 10 April 2013).
43. Wilf, M. *The Guidebook to Membrane Desalination Technology*; Balaban Desalination Publications: L'Aquila, Italy, 2007.
44. Hafez, A.; El-Manharawy, S. Economics of seawater RO desalination in the Red Sea region, Egypt. Part 1. A case study. *Desalination* **2003**, *153*, 335–347.
45. Ettouney, H.M.; El-Dessouky, H.T.; Faibish, R.S.; Gowin, P.J. Evaluating the economics of desalination. *Chem. Eng. Progr.* **2002**, *12*, 32–38.
46. Helal, A.; Al-Malek, S.; Al-Katheeri, E. Economic feasibility of alternative designs of a PV-RO desalination unit for remote areas in the United Arab Emirates. *Desalination* **2008**, *221*, 1–16.

47. U.S. Energy Information Administration. *Electric Power Monthly with Data for February 2013*; Technical report; U.S. Energy Information Administration, U.S. Department of Energy: Washington, D.C., USA, 2013.
48. Efraty, A.; Barak, R.N.; Gal, Z. Closed circuit desalination—A new low energy high recovery technology without energy recovery. *Desalin. Water Treat.* **2011**, *31*, 95–101.
49. Dreizin, Y. Ashkelon seawater desalination project—off-taker’s self costs, supplied water costs, total costs and benefits. *Desalination* **2006**, *190*, 104–116.
50. Lawson, K.W.; Lloyd, D.R. Membrane distillation. *J. Membr. Sci.* **1997**, *124*, 1–25.
51. Rodriguez-Maroto, J.; Martinez, L. Bulk and measured temperatures in direct contact membrane distillation. *J. Membr. Sci.* **2005**, *250*, 141–149.
52. Martinez-Diez, L.; Florido-Diaz, F. Desalination of brines by membrane distillation. *Desalination* **2001**, *137*, 267–273.
53. Song, L.; Li, B.; Sirkar, K.K.; Gilron, J.L. Direct contact membrane distillation-based desalination: Novel membranes, devices, larger-scale studies, and a model. *Ind. Eng. Chem. Res.* **2007**, *46*, 2307–2323.
54. Lee, H.; He, F.; Song, L.; Gilron, J.; Sirkar, K.K. Desalination with a cascade of cross-flow hollow fiber membrane distillation devices integrated with a heat exchanger. *AIChE J.* **2011**, *57*, 1780–1795.
55. Summers, E.K.; Arafat, H.A.; Lienhard, J.H., V. Energy efficiency comparison of single-stage membrane distillation (MD) desalination cycles in different configurations. *Desalination* **2012**, *290*, 54–66.
56. Saffarini, R.B.; Summers, E.K.; Arafat, H.A.; Lienhard, J.H., V. Economic evaluation of stand-alone solar powered membrane distillation systems. *Desalination* **2012**, *299*, 55–62.
57. Bui, V.; Vu, L.; Nguyen, M. Modelling the simultaneous heat and mass transfer of direct contact membrane distillation in hollow fibre modules. *J. Membr. Sci.* **2010**, *353*, 85–93.
58. Fath, H.E.; Elsherbiny, S.M.; Hassan, A.A.; Rommel, M.; Wiegghaus, M.; Koschikowski, J.; Vatansever, M. PV and thermally driven small-scale, stand-alone solar desalination systems with very low maintenance needs. *Desalination* **2008**, *225*, 58–69.
59. Banat, F.; Jwaied, N.; Rommel, M.; Koschikowski, J.; Wiegghaus, M. Desalination by a “compact SMADES” autonomous solar-powered membrane distillation unit. *Desalination* **2007**, *217*, 29–37.
60. European Desalination Society. *Desalination With Solar Energy*, Intensive Course. 2011.
61. Banat, F.; Jwaied, N. Economic evaluation of desalination by small-scale autonomous solar-powered membrane distillation units. *Desalination* **2008**, *220*, 566–573.