

# Focus on Basque Movements

by

Karlos Arregui-Urbina

B.A., English

University of Deusto, 1997

Submitted to the Department of Linguistics and Philosophy  
in partial fulfillment of the requirements for the degree of

Doctor of Philosophy

at the

MASSACHUSETTS INSTITUTE OF TECHNOLOGY

September 2002

© Massachusetts Institute of Technology 2002. All rights reserved.

Author ...

.....  
Department of Linguistics and Philosophy  
August 14, 2002

Certified by..

.....  
David Pesetsky  
Ferrari P. Ward Professor of Linguistics  
Thesis Supervisor

Accepted by ..

.....  
Alec Marantz  
Professor of Linguistics  
Head, Department of Linguistics and Philosophy

ARCHIVES ] 1

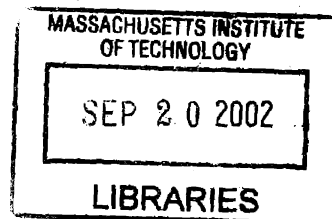



# Focus on Basque Movements

by

Karlos Arregui-Urbina

Submitted to the Department of Linguistics and Philosophy  
on August 14, 2002, in partial fulfillment of the  
requirements for the degree of  
Doctor of Philosophy

## Abstract

This thesis can be summarized in the following two objectives: (i) to develop a new version of the Nuclear Stress Rule (NSR) which overcomes certain problems found with previous versions, and (ii) to explain the so-called preverbal focus position in Basque in terms of the new NSR and prosodic principles imposed on focused phrases.

With respect to the NSR, I argue that certain generalizations about stress above the word level can be reduced to two basic syntactic properties of phrases: headedness and branchingness. The proposal is based on certain crucial insights found in previous work on the topic (Chomsky, Halle, and Lukoff 1956, Chomsky and Halle 1968, Liberman and Prince 1977, Halle and Vergnaud 1987, Cinque 1993, Zubizarreta 1998). The work reported in this thesis puts these insights together, resulting in a new version of the NSR, within the formalism of the metrical grid, which makes explicit reference to syntactic structure.

With respect to the preverbal focus position in Basque, I argue, contra much previous work on the topic, that it is not a syntactically defined position. Rather, it is to be explained in terms of certain prosodic conditions imposed on focused phrases. More specifically, focused phrases need to have primary stress in the sentence. The analysis is based on insights about the relation between syntax and discourse found in Cinque 1993, Zubizarreta 1998 and Reinhart 1995. The basic idea is that, given certain independently motivated hypotheses about Basque syntax, the NSR proposed in this thesis predicts that, in many cases, sentence stress is on the preverbal constituent. Since focused phrases need to have sentence stress, it follows that they must be in the preverbal position. However, in certain cases, the analysis correctly predicts that the focused phrase is not the one preceding the verb, but one containing the verb. I argue that this provides further evidence in favor of this analysis, and against analyses in which the preverbal focus position is defined syntactically.

Thesis Supervisor: David Pesetsky

Title: Ferrari P. Ward Professor of Linguistics



## Acknowledgments

I have probably learned most about linguistics from discussing problems with my professors, fellow students and visitors at MIT. This thesis, and all the work that I have done these five years, has benefited greatly from my interaction with them. Among the many people that have contributed to the research reported here, I would first like to mention the members of my thesis committee: Noam Chomsky, Danny Fox, Morris Halle, Sabine Iatridou, and David Pesetsky.

I would like to thank David Pesetsky for his continuing interest in my work since I came to MIT, and for being an excellent advisor and teacher. Most of the proposals presented in this thesis are the result of discussions we had in our meetings. What often started as a half-baked idea in my mind always became a full-blown hypothesis after talking with him. I would also like to thank him for encouraging me to pursue these ideas. His advice on linguistics and linguistic work has been invaluable.

When I arrived at MIT, I had an irrational fear of phonology. I thought that prosody was one of the most inscrutable areas in linguistics. After five years, I still think it is, but at least I have something to say about it. To a great extent, I owe this to Morris Halle. After our first meeting, he warned me: "Watch out, you might end up even *liking* phonology!" Talking with him about linguistics and other matters has always been a pleasure, and I have always learned something from it. His ideas about phonology, morphology, and linguistics in general have had an enormous influence in my work.

My heated discussions with Sabine Iatridou have always been fruitful. I have learned a lot from her insights and she has always been very helpful in clarifying my ideas. Her work on different topics in the syntax-semantics interface has been a great

source of inspiration. Noam Chomsky has always made sure that I didn't miss the forest for the trees. I thank him for showing me that things are simpler than what they appear to be on the surface. His faith in my ideas has encouraged me a great deal to continue my work. Danny Fox has always been a source of ideas, hypotheses, and new problems that need to be solved. More than once, what was supposed to be a simple question turned into a two hour discussion in which I always learned something new.

Words cannot express how grateful I am to Ikuska Ansola Badiola. Without her, this thesis would have been literally impossible. I have no doubt that I have the privilege of living with the best informant I know. Her judgements are always sharp, and when they are not, she will not stop until she finds a context in which a particularly complicated sentence is grammatical or not. Working with her has also proven to me that Ondarroa Basque is the most beautiful language in the world (*Bai oixe, matxi! Ori egi berdaderu re!*). Her support and love throughout all these years are the main reason that I came and stayed at MIT and did not become insane in the process. For this and much more, this thesis is dedicated to her.

This thesis has benefited greatly from discussions with Michael Wagner and Jon Nissenbaum. Michael Kenstowicz and Andrew Nevins read parts of this thesis, and I thank them for their detailed and insightful comments.

During these five years, I have learned a lot from discussions with Kai von Fintel, Ken Hale, Irene Heim, Alec Marantz, Shigeru Miyagawa, Norvin Richards, and Hubert Truckenbrot. I would also like to thank my other professors at MIT: Sylvain Bromberger, Michel DeGraff, Jim Harris, Jay Keyser, Utpal Lahiri, Howard Lasnik, Wayne O'Neil, Donca Steriade, Ken Wexler, and Cheryl Zoll.

I thank Isabel Oltra Massuet for being a great friend and an excellent colleague, and for showing me that a theme vowel is much more than a vowel. I would also like to thank Calixto Agüero Bautista, Rajesh Bhatt, Paul Elbourne, Dave Embick and Philippe Schlenker for innumerable discussions on linguistics, and for sharing their ideas with me. My stay here would not have been the same without the company of my classmates: Paul Elbourne, Elissa Flagg, Michela Ippolito, Julie Legate, Isabel

Oltra massuet, Liina Pykkänen and Andrea Rackowski.

Many other people have also contributed greatly to making me enjoy these last five years: David Adger, Teal Bissell, Jonathan Bobaljik, Ben Bruening, Guglielmo Cinque, Marie-Hélène Côté, Cristina Cuervo, Jessie Fermino, Beatriz Fernández, Olga Fernández, John Frampton, Jean-Pierre Gendreau-Hetu, Elena Guerzoni, Martin Hackl, Paul Hagstrom, Daniel Harbour, Patrick Hawley, Ken Hiraiwa, Shinichiro Ishihara, Meltem Kelepir, Connie Krause, Idan Landau, Vivian Lin, Luis López, Ora Matushansky, Andrew Nevins, Gina Rendon, Luigi Rizzi, Taylor Roberts, Juan Romero, Joey Sabbagh, Uli Sauerland, Luciana Storto, Kriszta Szendrői, Sonny Vu, Susie Wurmbrand, and many others that I hope will forgive me for not mentioning them here. I would also like to thank the staff at the Department of Linguistics and Philosophy, for making my life much easier than I deserved: Christine Graham, Mary Grenham, Stephanie Hanlon, Glenn Ketterle, Chris Naylor, Jen Purdy and Bev Stohl.

Before I came to MIT, my professors at the University of Deusto helped me realize that I need to do linguistics. I thank Jon Franco and Jon Ortiz de Urbina for all their help and for encouraging me to come to the States. I would also like to thank Manuel Brea-Claramonte and Peter Lavery for the first classes on Generative Grammar that I could make sense of. It is very unfortunate that I have not been able to keep in touch with them as much as I wanted to.

José Ignacio Hualde and Gorka Elordieta's work on Basque phonology, and their detailed studies of different Basque dialects have been a great source of inspiration, and an invaluable source of data and insights into the structure of this language.

Marie-Hélène Côté, Jean-Pierre Gendreau-Hetu, Vivian Lin, Jon Nissenbaum and Gina Rendon are dear friends who have made our life in Cambridge happier. I also want to thank Phoebe, Marielle and Emile for being Phoebe, Marielle and Emile.

Throughout my life, I have always had the love and support of my parents, Karlos Arregi and Maite Urbina. I thank them for believing in me and for teaching me to think on my own. I also want to thank Carmen Badiola for all her support and for treating me like a son.

I would like to thank Ortzi, Dexter and Eufemia for letting us live in their home,

and for having made our lives happier.

The research reported here was funded by grants from the MIT Department of Linguistics and Philosophy and the Department of Education of the Basque Government.

# Contents

<b>Abstract</b>	<b>3</b>
<b>Acknowledgments</b>	<b>5</b>
<b>Contents</b>	<b>9</b>
<b>Abbreviations</b>	<b>13</b>
<b>Basque Orthography</b>	<b>14</b>
<b>1 Introduction</b>	<b>15</b>
1.1 Overview . . . . .	15
1.2 A Note on the Data . . . . .	16
1.3 The Metrical Grid . . . . .	17
1.4 Chapter 2: Stress in Ondarroa Basque . . . . .	22
1.5 Chapter 3: The Nuclear Stress Rule . . . . .	25
1.6 Chapter 4: The NSR in Basque . . . . .	27
1.7 Chapter 5: Basque Movements and Focus . . . . .	29
<b>2 Stress in Ondarroa Basque</b>	<b>35</b>
2.1 Introduction . . . . .	35
2.2 The Basic Facts: Accented and Unaccented Words . . . . .	36
2.3 Word Level Stress . . . . .	41
2.4 Phrase Level Stress . . . . .	44
2.5 Conclusion . . . . .	53

## Appendices to Chapter 2

A	Monosyllabic Words and Underlying Tones . . . . .	54
A.1	Stress in Monosyllabic Words . . . . .	54
A.2	Hualde 1991a . . . . .	59
B	Stress, Vowel Deletion and Cyclicity . . . . .	62
<b>3</b>	<b>The Nuclear Stress Rule</b>	<b>71</b>
3.1	Introduction . . . . .	71
3.2	Halle and Vergnaud 1987 . . . . .	72
3.3	Cinque 1993 . . . . .	76
3.3.1	The NSR in Phrases . . . . .	76
3.3.2	Stress in Compounds . . . . .	83
3.3.3	The NSR and Syntactic Structure . . . . .	88
3.4	A Structure-Based Definition of the NSR . . . . .	96
3.4.1	Stress in Phrases . . . . .	97
3.4.2	Stress in Compounds . . . . .	106
3.5	Conclusion . . . . .	110
<b>4</b>	<b>The NSR in Ondarroa Basque</b>	<b>111</b>
4.1	Introduction . . . . .	111
4.2	Basic Clause Structure . . . . .	112
4.2.1	The Syntax of Verbs . . . . .	112
4.2.2	The Syntax of Arguments . . . . .	116
4.3	Sentence Stress . . . . .	118
4.4	Adverbials and the NSR . . . . .	127
4.5	The NSR and Movement . . . . .	129
4.5.1	Left Dislocation . . . . .	130
4.5.2	Right Dislocation . . . . .	134
4.5.3	Sentence Stress on Verbs . . . . .	136
4.5.4	Interim Conclusion . . . . .	138
4.6	Right Dislocation, Stress, and Verb Movement . . . . .	138

Contents	11
4.6.1 The NSR and Linear Order . . . . .	139
4.6.2 The Morphosyntax of Compound Tenses . . . . .	140
4.7 The Domain of Application of the NSR . . . . .	150
4.8 Sentence Stress and Depth of Embedding . . . . .	156
4.9 Conclusion . . . . .	159
<b>5 Basque Movements and Focus</b>	<b>161</b>
5.1 Introduction . . . . .	161
5.2 The Semantics of Focus . . . . .	163
5.3 The Preverbal Position in Basque . . . . .	165
5.4 The Preverbal Position and the NSR . . . . .	168
5.5 Focus and the Domain of Application of the NSR . . . . .	172
5.6 On Focus Movement . . . . .	175
5.7 Focus Projection . . . . .	179
5.8 Basque Movements and Economy . . . . .	189
5.8.1 The Problem . . . . .	189
5.8.2 The Semantics of Topic . . . . .	192
5.8.3 Left Dislocation . . . . .	194
5.8.4 Right Dislocation . . . . .	196
5.9 Long Distance Dependencies . . . . .	199
5.9.1 Long Distance Movement . . . . .	200
5.9.2 <i>Wh/F in situ</i> . . . . .	205
5.10 Basque Movements and Reconstruction . . . . .	210
5.11 Conclusion . . . . .	216
<b>6 Conclusion</b>	<b>219</b>
<b>Bibliography</b>	<b>221</b>



## Abbreviations

A, ABS	Absolutive
ABL	Ablative
ALL	Allative
BEN	Benefactive
COM	Comitative
D, DAT	Dative
DET	Determiner
E, ERG	Ergative
FUT	Future
G, GEN	Genitive
IMP	Imperfective
IN	Inesive
LGEN	Locative genitive
PL	Plural
PR	Present
PRF	Perfective
PST	Past
SG	Singular
SUP	Superlative

## Basque Orthography

All the Basque examples in this thesis are given in standard Basque orthography, except where phonetic detail is necessary. Basque orthography is straightforward in most cases, except in the following letters, listed with the corresponding IPA symbol:

- s apico-alveolar voiceless fricative, [s].
- tz dorso-alveolar voiceless affricate, [ts].
- x prepalatal voiceless fricative, [ʃ].
- tx prepalatal voiceless affricate, [tʃ].
- j velar voiceless fricative, [x], in Ondarroa;  
in other dialects, it corresponds to other phonemes.
- ll palatal lateral, [λ]; for some speakers, palatal voiced fricative [j].
- ñ palatal nasal, [ɲ].
- rr rhotic trill, [r] (used only between vowels.)
- r rhotic flap, [r], between vowels;  
elsewhere, the trill/flap distinction is lost, and only 'r' is used.
- dd voiced palatal stop, [dʒ].

# Chapter 1

## Introduction

### 1.1 Overview

This thesis can be summarized in the following two objectives: (i) to develop a new version of the Nuclear Stress Rule (NSR) which overcomes certain problems found with previous versions (see, among others, Chomsky and Halle 1968, Halle and Vergnaud 1987, Cinque 1993, Zubizarreta 1998), and (ii) to explain the so-called preverbal focus position in Basque in terms of the new NSR and prosodic principles imposed on focused and *wh*-phrases.

With respect to the NSR, I argue certain generalizations about stress above the word level can be reduced to two basic syntactic properties of phrases: headedness and branchingness. The proposal is based on certain crucial insights found in previous work on the topic (Chomsky, Halle, and Lukoff 1956, Chomsky and Halle 1968, Liberman and Prince 1977, Halle and Vergnaud 1987, Cinque 1993, Zubizarreta 1998). The work reported in this thesis puts these insights together, resulting in a new version of the NSR, within the formalism of the metrical grid, which makes explicit reference to syntactic structure.

With respect to the preverbal focus position in Basque, I argue, *contra* much previous work on the topic, that it is not a syntactically defined position. Rather, it is to be explained in terms of certain prosodic conditions imposed on focused phrases. More specifically, focused phrases need to have primary stress in the sentence. The analysis is based on insights about the relation between syntax and discourse found in Cinque 1993, Zubizarreta 1998 and Reinhart 1995. The basic idea is that, given

certain independently motivated hypotheses about Basque syntax, the NSR proposed in this thesis predicts that, in many cases, sentence stress is on the preverbal constituent. Since focused phrases need to have sentence stress, it follows that they must be in the preverbal position. In some cases, the analysis correctly predicts that the focused phrase is not the one preceding the verb, but one containing the verb. I argue that this provides further evidence in favor of this analysis, and against analyses in which the preverbal focus position is defined syntactically.

In the remainder of this chapter, I provide some important background for the analyses to be developed in later chapters, and briefly summarize the main results obtained in this thesis. In §1.2, I give some background on the Ondarroa dialect of Basque, on which the analysis is based. §1.3 is an overview of the formalism for representing stress adopted in this thesis, i.e. the metrical grid. Finally, §§1.4–1.7 provide an overview of the main conclusions reached in later chapters.

## 1.2 A Note on the Data

One of the most striking properties of Basque is the enormous variety of accentual dialects to be found in it. For instance, Hualde (1997) describes four major dialects, and provides detailed descriptions of twenty-four distinct subvarieties. Since the analysis of the syntax-discourse interface provided in this thesis relies strongly on stress, to provide a detailed account for all dialects would involve the addition of at least three hundred pages to this thesis. On the other hand, the main features of Basque syntax, as described in descriptive grammars (see, among others, Saltarelli 1988, Laka 1996), remain the same throughout all dialects. This means that, despite the variety in the stress systems, the main properties of stress at the phrasal level are expected to be the same in all of them. That is why I have decided to concentrate on a single dialect, the one spoken in the town of Ondarroa.<sup>1</sup> This allows us to examine in detail

---

<sup>1</sup>The main reason for not choosing *Batua*, the current standard dialect, is that it does not have an established accentual system. This standard dialect, which is not based on any specific local variety, was created and has been regulated by *Euskaltzaindia* (The Academy of the Basque Language) since the sixties. Therefore, at this point, most speakers of this dialect do not speak it natively. To the best of my knowledge, there has been no systematic attempt to describe the accentual system of

the predictions about Basque syntax and phonology made in this thesis.

Ondarroa is the easternmost town in the western province of Biscay. As in many other towns in this province, its accentual system can be described as a ‘pitch accent’ system: stress is realized as tone contours whose distribution depends on the placement of stress in words and phrases. The accentual data from this dialect discussed in chapter 2 (and summarized in §1.4 below) is taken mainly from Hualde 1991a, 1996, Elordieta 1997a, and from my own field work (see the introduction to chapter 2 for a more extensive list of references).

To the extent that the syntax of other dialects is the same as Ondarroa Basque, the analysis of sentence stress and focus presented in this thesis can be applied to all of them without major changes. Due to the great variety in accentual systems in Basque, some variation is expected, but the main predictions of the analysis are the same for all dialects. Given time and space limitations, a more detailed account of the facts in other dialects in terms of the theory presented in this thesis is left for future work.

### 1.3 The Metrical Grid

Throughout this thesis, I shall assume that the metrical grid is the correct formalism to describe the placement of stress (see, among others, Liberman 1975, Liberman and Prince 1977, Prince 1983 and Halle and Vergnaud 1987). In particular, I adopt Idsardi’s (1992) version of the metrical grid (see also Halle and Idsardi 1995, Halle 1998, Purnell 1997). In this section, I sketch the main features of this theory.

One of the major insights guiding modern work on stress is Liberman’s (1975) idea that stress is not a phonetic feature of segments, but the reflection of a grouping of syllables (or stress bearing units) into higher units called *feet*. In the notation of the metrical grid, this grouping is formalized as follows. Certain segments in the string

---

native speakers of this dialect. Surprisingly, as noted by Hualde (1997, §5.8), many of those who learn Batua as a second language seem to follow a very specific and regular accentual pattern, even though, generally, no explicit instruction is given on what accentual system they should use. This is true both for native speakers of other dialects, and for those whose first language is not Basque. In any case, at present, there is not sufficient data available on which an analysis could be based.

are designated as *stress bearing units*, i.e. segments which can in principle bear stress. The particular choice of stress bearing units varies from language to language. In the two languages discussed in this thesis, English and Basque, these are all and only the vowels that are syllable nuclei. Stress bearing units are distinguished formally from other segments by projecting onto a separate autosegmental *metrical plane* in the form of *grid elements* (represented as asterisks ‘\*’). The metrical plane contains several lines (numbered 0, 1, ...) containing one or more grid elements, each corresponding to some segment in the string of phonemes. The resulting representation has the shape of a grid, and can accordingly be called a *metrical grid*. The level of prominence (stress) assigned to a given segment is a function of the number of lines in which there is a grid element linked to the segment: the higher the line a given segment projects onto, the higher its prominence. In the following representation of the English word *execution*,

(1)

*		line 2		
*	*	line 1		
*	*	*	*	line 0
execution				

the segment *u* has more prominence than the segment *e* in the first syllable, which in turn is more prominent than the other two syllable nuclei.

Halle and Vergnaud (1987) (H&V) propose that projection to lines higher than 0 is a reflection of the grouping of grid elements into feet. Within each foot, one grid element is designated as the “metrical head” of the foot, which means that it is projected onto the next higher line in the grid. The boundaries of feet are represented with parentheses—‘)’ for the right boundary, and ‘(’ for the left boundary. The example given above would then be represented as:

(2)

*		line 2				
(	*	)	line 1			
(	*	)	*	)	*	line 0
execution						

On line 0, there are two left-headed feet. Line 1, on the other hand, contains a single



from the Leka dialect of Russian. As argued by Halle, certain rules are sensitive to the distinctions that are representable in Idsardi's formalism but not in other theories (see Halle 1998, p. 545–547 for details). Further evidence for the need of this richer formalism is given in Purnell 1997.

Giving parentheses the status of primitives also provides a unified way of representing accented morphemes, i.e. morphemes that determine placement of stress on some specified vowel in the word. For instance, in Spanish, some morphemes are lexically specified as being stressed on their penultimate vowel. Thus, compare *género* [xener+o] 'gender' and regularly stressed *dinéro* [diner+o] 'money'. Some suffixes are also exceptional in this way, except for the fact that, since they only contain a single vowel, stress is not on the suffix itself, but on the preceding vowel. A relevant example is the suffix *-ic*: *tónico* /ton+ik+o/ 'tonic' vs. regularly stressed *toníto* /ton+it+o/ 'small tone'. In Idsardi's formalism, this can be easily expressed in a unified way by placing a right parenthesis to the left of the last grid element in the exceptional morpheme: e.g. /xener/ and /-ik/.<sup>4</sup>

On the other hand, in H&V's formalism, these facts cannot be represented in a unified way. Since parentheses are not primitives, it cannot be done by inserting a parenthesis in some position in the morpheme. In the case of the root *gener*, it can be represented by having it project a grid element on line 1 corresponding to its penultimate vowel. This, however, is not possible for the suffix *-ic*, since it does not have a penultimate vowel. A separate rule is needed for this case. Thus, this formalism cannot capture the facts in a unified way.<sup>5</sup>

<sup>4</sup>This assumes, following Roca 1997 and Arregi and Oltra-Massuet 2001, that feet are right-headed in Spanish. In Harris's (1995) analysis, where feet are left-headed, these morphemes would be represented with a right parenthesis to the right of their last grid element. This detail does not alter the argument made in the text.

<sup>5</sup>Roca (1988) provides the following analysis within a formalism similar to H&V's. The last vowel in exceptional morphemes such as *gener* or *-ic* is lexically specified to be extrametrical. In simple examples, this correctly predicts that stress is shifted to the left, giving *género* (/xener+o/) and *típico* (/tip+ik+o/). However, words containing two exceptional morphemes, e.g. /xener+ik+o/ would be wrongly predicted to be stressed on the first syllable, i.e. on the one preceding both extrametrical segments. Roca proposes that, within a word, only the last vowel in the stem can be extrametrical, giving, as desired, *genérico*. In Idsardi's formalism, this stipulation is not necessary. As shown in Arregi and Oltra-Massuet 2001 the facts follow from the analysis of exceptional morphemes sketched in the text, and from the fact that feet are right-headed on line 1.

So far, we have seen how parentheses have an effect on the projection of the grid, but not much has been said about how parentheses themselves are inserted. Idsardi (1992) and Halle and Idsardi (1995) identify three mechanisms. One is the insertion of a parenthesis mark some syllable with special properties. One example was provided above: some morphemes are lexically specified as having a parenthesis inserted in some specific position in the word. Another possibility consists in inserting a left or right parenthesis to the left or right of a grid element linked to a heavy syllable.

Another mechanism proposed by the authors cited above is insertion of parentheses at the edges of the string. These are termed *edge-marking* rules. These rules have the following general form:

- (5) Insert a left/right parenthesis to the left/right of the left-/rightmost grid element.

They are accordingly called LLL, RRR, LRL, RLR, etc.:

- |  |  |
|--|--|
| (6) a. RRR: $\emptyset \rightarrow ) / *\_]$<br>*****) | b. LLL: $\emptyset \rightarrow ( / [\_*$<br>(***** |
| c. RLR: $\emptyset \rightarrow ) / \_*$<br>*****)      | d. LRL: $\emptyset \rightarrow / [\_*$<br>*(*****  |

In §2, I provide several cases of this type of rule, and discuss their effect on stress placement.

Finally, parenthesis can also be inserted iteratively, forming several (binary) feet in a word. Iterative foot construction results in the rhythmic patterns characteristic of languages like English.<sup>6</sup>

To summarize, the stress rules in a given language generate a metrical grid for each string (word, phrase, etc.) by specifying, for each line in the grid, where parentheses are inserted, and what element in each foot (the leftmost or rightmost) is its head (i.e. projects to the next line).

---

<sup>6</sup>Since none of the analyses proposed in this thesis need iterative foot construction, I do not provide any relevant examples here. See Idsardi 1992 and Halle and Idsardi 1995 for details and discussion.

#### 1.4 Chapter 2: Stress in Ondarroa Basque

In this chapter, I provide an analysis of the basic facts of the accentual system of Ondarroa Basque within the framework sketched in the previous section. Certain aspects of the data and analysis discussed in this chapter are crucial in order to understand the effects of the NSR in this dialect. Since Ondarroa Basque is a pitch accent language, it is not clear how the notion of ‘stress’ can be applied in a meaningful way to describe the facts. In fact, Hualde (1991a), in the first detailed generative analysis of the pitch accent dialects of Basque, proposes a purely tonal analysis. Following much subsequent work in the literature on Basque phonology (see, among others, Hualde 1991b, Elordieta 1997a), I propose a metrical analysis of the facts, in which the surface distribution of tones is the result of metrical rules and rules that assign tone contours by making reference to the metrical grid. The analysis is based on similar ones proposed by Purnell (1997) for other so-called ‘tone’ and ‘pitch accent’ languages.

The hypothesis that the distribution of tones in this language is a reflection of stress and the metrical grid is crucial in the explanation of the sentence level prosodic facts, and of their relation to focus. If there were no such thing as stress in this language, the NSR could not apply to it, and notions such as ‘sentence stress’ would not be relevant. The fact that, as shown in chapters 4–5, the NSR plays a crucial role in explaining the relevant prosodic, syntactic and semantic facts discussed in this thesis provides strong support for this hypothesis.

In Ondarroa Basque, as in other pitch accent languages, there are two types of words. Accented words always contain a drop in pitch starting on some specific syllable, and unaccented words contain a drop in pitch only in certain syntactic environments. The basic facts can be summarized as follows:

- (7) a. An accented word contains a drop in pitch beginning on its penultimate syllable.
- b. A phrase contains a drop in pitch beginning on its penultimate syllable.
- c. A word contains a rise in pitch in phrase initial position and when

following an accented word within the same phrase.

- d. All syllables between a rise and a fall in pitch are linked to a high tone.

The following are some relevant examples:

- (8) a. *Isolated unaccented word:*

barbero + antzako    barberuntzako  
barber      BEN.SG

- b. *Isolated accented word:*

belarri + antzako    belarrixantzako  
ear      BEN.SG

- c. *Unaccented + unaccented*

gixon andi+a      gixon andixe  
man big.A.SG

- d. *Accented + unaccented*

belarri andi+a      belarri andixe  
ear      big+A.SG

- e. *Unaccented + unaccented + unaccented:*

gixon andi+an ixen+a      gixon andixan ixenna  
man big+G.SG name.A.SG

- f. *Unaccented + accented + unaccented:*

nire auma+an      ixen+a      nire auman ixena  
my grandmother+G.SG name.A.SG

- g. *Unaccented+unaccented+accented+unaccented:*

nire ama+an      lagun+an      txakur+a  
my mother+G.SG friend+G.PL dog+A.SG  
nire aman lagunan txakurre

In order to account for these facts, I propose that a rise in pitch corresponds to a left parenthesis on line 0 in the grid, and a fall in pitch corresponds to a right parenthesis on line 0:

- (9)  $\sigma \overline{\sigma\sigma \dots \sigma\sigma} \sigma$

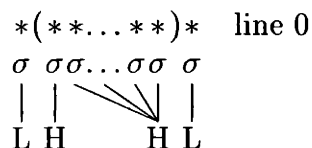

The metrical grid for each phrase is computed in two separate cycles: the word and the phrase. In accented words, the right parenthesis is inserted at the word level. In phrases, it is inserted at the phrase level. This accounts for all the falls in pitch that can be seen in the data above. With respect to the rise in pitch appearing at the beginning of some words, it is not clear that there is a uniform way of characterizing them: they are the ones appearing in phrase initial position, and those appearing after an accented word. However, those that do *not* have an initial rise can be characterized in a uniform manner: they are the ones that appear preceded by an unaccented word. Thus, I propose that, at the word level, all words contain a left parenthesis, and that this parenthesis is deleted at the phrase level when the word is preceded by an unaccented word.

This rough sketch of the analysis developed in more detail in chapter 2 is sufficient to account for all the relevant facts. However, nothing has been said so far as to what constitutes a ‘phrase’ for the stress rules. As shown above, a phrase is necessarily delimited by a rise in pitch at the beginning, and by a fall at the end. Since accented words introduce rises and falls that do not necessarily coincide with phrase edges, the relevant examples which can be used to determine what counts as a phrase for the stress rules are those which contain only unaccented words, i.e. (8a,c,e). In these three examples, all of which are DPs, the internal structure of the DP seems to be irrelevant for stress. Thus, the AP *andixe* ‘big’ in (8c) does not start with a rise, and the genitive DP *gixon andixan* ‘man big’ in (8e) does not end with a fall. Thus, a DP counts as a phrase for the stress rules, and any phrase contained in it (even other DPs) is irrelevant for stress. In this thesis, I will not have much to say about why Ondarroa Basque (and other dialects) imposes this particular restriction on the application of phrase level stress rules. Nevertheless, as shown in later chapters (specifically, §§4.7, 5.5), this restriction plays an important role in the description and analysis of sentence stress and its relation to focus in this dialect.

### 1.5 Chapter 3: The Nuclear Stress Rule

In chapter §3, I argue that the NSR makes direct reference to syntactic structure. In particular, I propose a new version of the NSR in which prominence depends primarily on two aspects of syntactic structure: headedness and branchingness.

Since Chomsky, Halle, and Lukoff's (1956) seminal work on English stress, it is well-known that syntactic structure influences the distribution of primary and lower levels of stress in a sentence. This is reflected in the use of the cycle in the computation of stress. However, within each cycle, stress placement is determined by rules which are based on linear order. For instance, in Chomsky and Halle 1968 (SPE), primary stress within each cycle is assigned to the leftmost or rightmost peak (in compounds and phrases, respectively). This assumption is adopted in some form or another in later proposals which use different notations (e.g. the labeled tree notation in Liberman 1975, Liberman and Prince 1977, and the grid in Prince 1983, Halle and Vergnaud 1987). In some of these works, some reference is made to syntactic structure in the stress rules, but linear order is still crucial. For instance, in Liberman and Prince's (1977) Compound Stress Rule, primary stress is assigned to the rightmost constituent only if it branches.

Cinque 1993 claims that, in many cases, linear order is not necessary in determining primary stress in each cycle. He shows that whether stress is leftmost or rightmost in a phrase is predictable given independent syntactic properties of the phrase. The two main generalizations that he discusses are the following:

- (10) a. In a head-complement structure, the complement is more prominent than the head.
- b. In a specifier- $\bar{X}$  structure,  $\bar{X}$  is more prominent than the specifier.

Cinque argues that (10a) is a direct consequence of (i) cyclic rule application, and (ii) a basic asymmetry between heads and complements in  $\bar{X}$ -Theory. In this theory of phrase structure, it is stipulated that complements are phrasal. This means that a head-complement structure has at least the following structure:

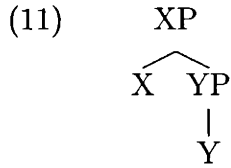

Cinque shows that this basic asymmetry can account for (10a) if we adopt a simple version of the NSR. The basic idea is that, the more times the NSR applies to constituents containing a word, the higher its column is going to be in the metrical grid. Thus, the basic prediction of this analysis is that primary stress within a sentence is on the most deeply embedded word.

As noted by Cinque himself, this creates a problem for the generalization in (10b). A specifier is always less prominent than its sister, even in cases in which it contains the most deeply embedded word in the structure. He proposes a solution to this problem by assuming that the metrical grid computed for a specifier is only visible as a single asterisk in the computation of primary stress for the whole sentence. Thus, specifiers in this analysis are basically treated as if they had no internal structure, and depth of embedding within them does not ‘count’.

I propose a new version of the NSR which provides a unified account of the two generalizations in (10), and which does not need the additional assumptions about syntactic structure needed by Cinque’s version. The basic idea is that these generalizations can be reduced to the following statement:

- (12) In a structure of the form  $[\gamma \alpha \beta]$  (order irrelevant), where  $\alpha$  is the head of  $\gamma$ ,  $\alpha$  is more prominent than  $\beta$  iff  $\alpha$  is branching.

In a specifier- $\bar{X}$  structure,  $\bar{X}$  is the head and is branching, so  $\bar{X}$  is more prominent than its sister (cf. 10b). In a head-complement structure, the head is not branching, so the complement is more prominent than the head (cf. 10a). Accordingly, in chapter 3, I propose that the NSR makes crucial reference to syntactic headedness and branchingness. As I argue there, this new version of the NSR accounts for the stress pattern of different types of phrases in both English and German, and for stress in English compounds.

## 1.6 Chapter 4: The NSR in Basque

Chapter 4 brings together the results from the previous two chapters in order to account for the distribution of primary stress within sentences in Ondarroa Basque. In neutral contexts, a transitive sentence has the order SOV, and sentence stress is on the object:<sup>7</sup>

- (13) Mirenek **Jón** ikusi rau.  
 Miren.E Jon.A see.PRF Aux.PR  
*Miren has seen Jon.*

Following Laka 1990 and Arregi 2000, I assume that Basque sentences have the following basic structure:<sup>8</sup>

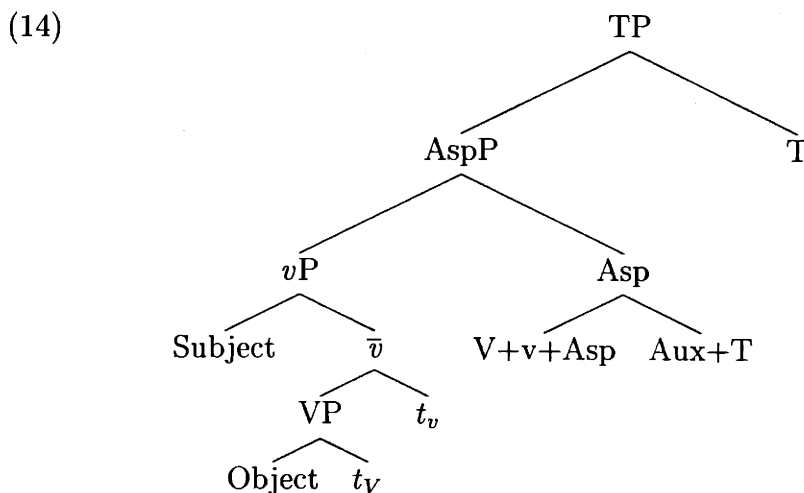

In this structure, the V+v complex moves to Asp, in order to form a *participle*. Furthermore, an auxiliary verb is inserted in T. At PF, the Aux+T complex is lowered to Asp. Following standard terminology in the literature on Basque, I refer to the resulting complex head as the *verb complex*.

The NSR proposed in chapter 4 correctly predicts that sentence stress in cases like this is on the object. First, within  $\bar{v}$ , the object is the most prominent constituent,

<sup>7</sup>By 'neutral context', I mean a context in which the sentence can be understood as an answer to questions like *What happened?*, and in which no constituent is understood as given. See chapter 5 for details.

<sup>8</sup>This structure corresponds to transitive sentences with compound tenses. See chapter 4 for other types of sentences and for sentences with simple tenses.

since it is the only overt one. Within  $vP$ ,  $\bar{v}$  is more prominent than the subject, since the former is the branching head of  $vP$ . Within  $AspP$ ,  $vP$  is more prominent than the verb complex in  $Asp$ , since the former is the complement of the latter.<sup>9</sup> Finally, within  $TP$   $AspP$  is the most prominent constituent, since it is the only one containing overt material. The result, as desired, is that sentence stress is on the object.

Since the NSR is dependent on syntactic structure, this analysis predicts that movement can have an effect on the placement of sentence stress. In this chapter, I discuss two such movements in Basque: left and right dislocation. These are illustrated with movement of the object in the following two examples:

- (15) a.  $[_{TP} \text{Jon } [_{TP} \text{Miréne}k \ t \text{ ikusi } \text{rau} ] ]$ .  
           Jon.A       Miren.E     see.PRF Aux.PR  
           *Jon, Miren has seen.*
- b.  $[_{TP} [_{TP} \text{Miréne}k \ t \text{ ikusi } \text{rau} ] \text{Jon} ]$ .  
           Miren.E     see.PRF Aux.PR   Jon.A  
           *Miren has seen Jon.*

As shown in these examples, I assume that both movements result in adjunction to  $TP$ . The NSR proposed in this thesis correctly predicts that, in both cases, sentence stress is on the subject.

In all the cases seen so far, sentence stress is on the constituent preceding the verb. In sentences in which both subject and object are dislocated, the NSR correctly predicts that sentence stress is on the verbal complex:

- (16) a.  $[_{TP} [_{TP} [_{TP} \ t \ t \ \text{Ikusi} \ \text{rau} ] \text{Jon} ] \text{Mirenek} ]$ .  
           see.PRF Aux.PR   Jon.A   Miren.E  
           *Miren has seen Jon.*
- b.  $[_{TP} [_{TP} \text{Mirenek} [_{TP} \ t \ t \ \text{ikusi} \ \text{rau} ] ] \text{Jon} ]$ .  
           Miren.E           see.PRF Aux.PR           Jon.A  
           *Miren has seen Jon.*

<sup>9</sup>The fact that the head  $Asp$  is branching is irrelevant, since structure below the word is invisible to the NSR.

Thus, Ondarroa Basque provides further support for the version of the NSR proposed in this thesis.

A crucial hypothesis in the present analysis is that phrases appearing to the right of the verb are right dislocated. However, this hypothesis has been challenged in the literature. In particular, Elordieta (2001) claims that there is no rightward movement in Basque. The appearance of phrases to the right of the verb in examples like (15b) above is the result of leftward movement of the verbal complex:

(17) [ Subject [ [V-Aux] [ Object *t*]]]

If this were the right structure, the NSR would predict that sentence stress is on the object, which is contrary to fact. This would force us to propose a language-particular version of the NSR based on linear order rather than syntactic structure. This NSR would state, roughly, that sentence stress is on the constituent preceding the verb. However, this would be little more than a mere description of the facts. On the other hand, the NSR proposed in this thesis explains why sentence stress is on the preverbal constituent. Furthermore, it also explains in a unified way the placement of sentence stress in both Basque and English. Surface differences between the two languages are seen as the result of independently motivated syntactic differences between them. Since the hypothesis that Basque has right dislocation is crucial in accounting for the sentence stress facts, the NSR provides strong support for this hypothesis.

## 1.7 Chapter 5: Basque Movements and Focus

One of the most studied properties of Basque syntax is its preverbal focus position. In this language, a *wh* or focused phrase (*wh/f*-phrase) must be left-adjacent to the verbal complex. This is exemplified in the question-answer pairs in (18–19).

(18) Q: Jon    **señek** *t* ikusi    rau?  
           Jon.A who.E    see.PRF Aux.PR  
           *Who saw Jon?*

A: Jon **Mirenek** *t* ikusi rau.  
 Jon.A Miren.E see.PRF Aux.PR  
*MIREN saw Jon.*

(19) Q: **Señek** *t* ikusi rau Jon?  
 who.E see.PRF Aux.PR Jon.A  
*Who saw Jon?*

A: **Mirenek** *t* ikusi rau Jon.  
 Miren.E see.PRF Aux.PR Jon.A  
*MIREN saw Jon.*

In (18), the subject is left-adjacent to the verbal complex as a result of left dislocation of the object. In (19), the subject is left-adjacent to the verbal complex as a result of right dislocation of the object. If, on the other hand, there is no left or right dislocation of the object, the subject cannot be a *wh/f*-phrase, but the object can:

(20) Q: \***Señek** Jon ikusi rau?  
 who.E Jon.A see.PRF Aux.PR  
*Who saw Jon?*

Q': Mirenek **sein** ikusi rau?  
 Miren.E who.A see.PRF Aux.PR  
*Who did Miren see?*

A: Mirenek **Jon** ikusi rau.  
 Miren.E Jon.A see.PRF Aux.PR  
*Miren saw JON.*

In this chapter, I argue that this condition is derived from the following principle:

(21) The F-marked phrase in a sentence must contain the primary stress in that sentence.<sup>10</sup>

(See Chomsky 1971, Jackendoff 1972, Truckenbrodt 1995, Zubizarreta 1998, Reinhart 1995.)

<sup>10</sup>As we will see in chapter 5, this principle needs to be slightly modified in order to accommodate certain restrictions on the NSR discussed in chapter 4.

As argued for in chapter 4 (see the summary in §1.6), the NSR predicts that sentence stress in Basque is assigned to the constituent immediately preceding the verbal complex. In (18-19), where the subject is the *wh/f*-phrase, this condition is satisfied by moving the object from its preverbal position. In (20), the object receives sentence stress, so the object, not the subject can be a *wh/f*-phrase. This analysis follows recent works on the syntax of focus in several languages, including Vallduví 1992, Zubizarreta 1998 and Reinhart 1995.

One of the main advantages of the this analysis is that it can account for *focus projection* facts in a unified way in both Basque and English:

- (22) Jonek **káfi** era ban.  
 Jon.E coffee.A.SG drink.PRF Aux.PST  
*Jon drank COFFEE.*

Possible focus readings:  $\text{Obj}_F$ ,  $[\text{Obj V}]_F$ ,  $[\text{Sbj Obj V}]_F$

In both Basque and English, this sentence has three possible focus readings. According to (21), the focused phrase needs to contain sentence stress. Sentence stress is on the object, and, accordingly, each focus reading corresponds to some constituent containing the object: the object, object-verb, and subject-object-verb.

In this analysis of Basque focus, the focus projection facts are analyzed in the same way as in English, thus capturing an important crosslinguistic generalization: sentence stress on the object can yield three different focus readings in sentences of this type.

I compare this analysis with previous ones in which it is claimed that Basque has a syntactically defined overt focus position. In particular, Ortiz de Urbina (1989) (see also Elordieta 2001) proposes that the preverbal position is to be analyzed in terms of movement of the *wh/f*-phrase to  $[\text{Spec}, \text{CP}]$ . Adjacency with the verb is the result of movement of the verbal complex to the head of CP, which, by hypothesis, is left-headed in Basque:

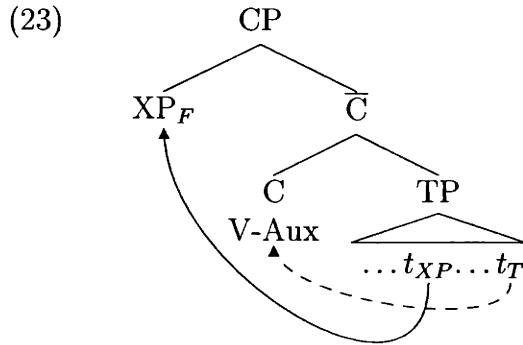

In this analysis, the focus projection facts cannot be analyzed in a uniform way in both Basque and English. Since the hypothesis is that the focused phrase moves to [Spec, CP], it follows that different focus readings correspond to different syntactic structures (i.e. different constituents in [Spec, CP]). Since English does not have (overt) movement of the focused phrase, the facts in Basque and English are not analyzed in a uniform manner. Thus, this analysis fails to capture an important generalization which is captured in the analysis defended in this thesis.

This chapter also discusses certain cases in which the PF condition introduced above seems to make wrong predictions:

- (24) a.  $\overbrace{\text{Maxe } \text{Jónék } t \text{ apurtu } \text{rau.}}^{\downarrow}$   
 table.A.SG Jon.E break.PRF Aux.PR  
*Jon has broken the table.*  
 Possible focus readings: Sbj<sub>F</sub>, [Sbj V]<sub>F</sub>, but \*[Obj Sbj V]<sub>F</sub>
- b.  $\overbrace{\text{Jónék } t \text{ apurtu } \text{rau } \text{maxe.}}^{\downarrow}$   
 Jon.E break.PRF Aux.PR table.A.SG  
*Jon has broken the table.*  
 Possible focus readings: Sbj<sub>F</sub>, [Sbj V]<sub>F</sub>, but \*[Obj Sbj V]<sub>F</sub>

These sentences have all the expected focus readings, except the one that includes the left or right dislocated object. It seems that movement of the object ‘removes’ it from the focus. The result is that the only available focus readings are those which would not be available had the movement not applied. Thus, it is tempting to account for these facts in terms of an economy condition that would restrict movement to cases in which the movement yields a new focus reading.

In this chapter, I argue that this economy condition is not necessary, and that, in the case of right dislocation, it makes wrong predictions. The basic idea is that these movements have certain discourse properties which can account for all the relevant facts:

- (25) a. A left dislocated XP is interpreted as a topic.  
 b. A right dislocated XP is interpreted as given.

If a phrase is interpreted as a topic, it cannot be part of the focus. This explains the fact that the left dislocated object cannot be part of the focus in (24a). Thus, the economy condition is not necessary, at least with respect to left dislocation.

In the case of right dislocation, the present analysis in fact predicts that a right dislocated phrase can be interpreted as part of the focus *as long as it is also interpreted as given*. The following is a relevant example:

- (26) Q: Jonek klasi amatxu te gero, se pasa san?  
 Jon.E class.A.SG finish.PRF and later what.A happen.PRF Aux.PST  
*After Jon finished the class, what happened?*
- A: **Jún** ein san Jon.  
 go.PRF do.PRF Aux.PST Jon.A  
*Jon left.*

In the question, Jon is mentioned. Accordingly, the subject *Jon* is right dislocated in the answer, since it is given. Furthermore, the question is *What happened?*, which means that the answer is interpreted with focus on the whole sentence. Since the answer is felicitous, it follows that the right dislocated subject *is* part of the focus.

Therefore, in certain contexts, as predicted, right dislocated phrases can be understood as part of the focus. In these cases, the economy condition would clearly make wrong predictions.

This chapter concludes with two further issues in the syntax of focus in Basque. First, I discuss certain cases of long distance movement of *wh/f*-phrases, and propose an analysis in terms within the framework adopted in this thesis. The final section of this chapter examines certain predictions made by the current analysis with respect to

the scope of left and right dislocated phrases. This section provides further evidence for the existence of right dislocation in Basque, and for the general approach to the syntax of focus in Basque defended in this thesis.

## Chapter 2

### Stress in Ondarroa Basque

#### 2.1 Introduction

In this chapter, I provide an analysis of the basic facts of the accentual system of Ondarroa Basque within the framework of the metrical grid. Certain aspects of the data and analysis discussed in this chapter are crucial in order to understand the analysis of sentence stress and focus developed in later chapters.

The variety of Basque spoken in the western coastal town of Ondarroa belongs to the Biscayan dialect. As in many other varieties within this dialect, prosodic prominence is realized as pitch accent. The main features of the Ondarroa accentual system are described and analyzed in Hualde 1995, 1996, and in Hualde 1991a, 1997, 1999a, which also contain extensive descriptions of other Basque accentual systems. Other varieties related to Ondarroa Basque are described in Hualde 1991b, Hualde and Bilbao 1993, Hualde 2000, Hualde, Elordieta, and Elordieta 1994 and Elordieta 1997a. Of particular interest for our purposes are the latter two works, since they offer detailed description and analysis of the accentual system used in Lekeitio, which is a town neighboring Ondarroa. The data presented and analyzed below are taken from several of these works, and from my own field work.

As noted by Hualde (1991a), the accentual system used in Ondarroa and many other Vizcayan towns is very similar to the Japanese accentual system. First, there are two types of words: *accented* and *unaccented*. Second, prominence in accented words is realized as a fall in pitch starting on some specific syllable, the *accented*, or *stressed* syllable. On the other hand, unlike Japanese, unaccented words can contain

a pitch drop in certain syntactic positions to be specified below. These facts are analyzed in the following sections in terms of a metrical grid, i.e. the tonal contours appearing in the words and phrases in this dialect are the realization of metrical structure imposed on them. In this respect, I follow several of the works on the pitch accent dialects of Basque mentioned above<sup>1</sup> and other pitch accent languages (see, for instance, McCawley 1968, Prince 1983, Tenny 1986, Watanabe 1991, Idsardi and Purnell 1997, Purnell 1997 for Japanese).

This chapter is organized as follows. In §2.2, I present the basic facts of the accentual system in Ondarroa Basque, and show that there are two basic types of words accentually: accented and unaccented. In §2.3, I propose an analysis of these word level accentual facts based on the metrical grid. §2.4 presents data which show that the prosodic patterns created at the word level undergo certain changes at the phrase level, which justify certain additions to the analysis proposed in the previous section. Finally, the appendices to this chapter provide further extensions to the analysis, justified by data having to do with monosyllabic words and with words ending in vowel clusters.

## 2.2 The Basic Facts: Accented and Unaccented Words

As noted above, there are two types of words in the Ondarroa accentual system: accented and unaccented. The former are always stressed, i.e. they always contain a drop in pitch beginning on some specified syllable. On the other hand, unaccented words are stressed only in certain syntactic environments (see §2.4 below). Whether a given word is accented or not is a lexical property of its constituent morphemes, i.e. if a word contains a *marked* morpheme, then it is accented.<sup>2</sup> Furthermore, whether

---

<sup>1</sup>In particular, Hualde (1991b) is the first one to propose a metrical analysis for these dialects. Previously, Hualde (1991a) had offered a tonal analysis which did not involve a metrical grid. See Hualde and Bilbao 1993 for arguments in favor of the metrical analysis over the purely tonal one.

<sup>2</sup>Note that I have chosen the term *marked*, rather than *accented*, to refer to morphemes which determine that a given word is accented. The reason for this terminological point will become clear below, where it is shown that, even though a marked morpheme makes the word containing it accented, the accent does not necessarily fall on the marked morpheme itself. Thus, calling these morphemes *accented* would be somewhat misleading.

a given morpheme is marked or not is an idiosyncratic property of that morpheme.

Some relevant examples of accented words are listed in (1). In each word, the morpheme which is marked (i.e. responsible for the word being accented) is annotated with an apostrophe ('). The examples in (1b-d) are given in their surface forms when uttered in isolation. The uninflected form in (1a) is given in phrase initial position, followed by the determiner *bat* 'a', since uninflected forms are not possible in isolation.<sup>3</sup>

(1) *Accented words*

a. *Uninflected marked root*

/leko'/ 'place' leko bat

b. *Marked root + unmarked suffix*

/leko'+ra/ 'place+ALL.SG' lekure

c. *Marked root + marked suffix*

/leko'+tik'/ 'place+ABL.SG' lekutik

d. *Unmarked root + marked suffix*

/esko+agas'/ 'hand+COM.SG' eskuas

As can be seen in these examples, either the root, such as /leko'/ 'place', or a suffix, such as /-tik'/ 'ABL.SG', can be marked. As can be seen in the surface forms, all words containing one or more marked morphemes are stressed on some syllable, that is, they contain a drop in pitch beginning on that syllable. Other relevant examples for all the cases in (1) are given in table 2.1 on page 38.<sup>4,5</sup>

<sup>3</sup>This is because all DPs and APs must contain some inflectional ending, a determiner, or both.

<sup>4</sup>In some of the words in (1) and table 2.1, there are rules of segmental phonology involved in the derivation of the surface forms. See Hualde 1991a (§2.5) for details of these rules in Ondarroa Basque. Another fact which has been ignored for ease of exposition is that many of the inflectional suffixes in the examples are decomposable into a determiner morpheme (which inflects for number), and a case morpheme. For instance, commitative plural /-akin'/ (see table 2.1) is in fact composed of the plural determiner /-a'/ and the commitative case morpheme /-kin'/ . For details of the Basque number and case inflectional system, see Arregi 1999 and references cited there.

<sup>5</sup>Some of the examples contain diphthongs, a fact which is important in determining the placement of stress. Where relevant, the vowels forming the diphthongs are linked by an arch ( ^ ).

<i>Uninflected marked root</i>		
/leko'/	'place'	le <u>ko</u> bat
/txisto'/	'flute'	txis <u>to</u> bat
/lenguso'/	'cousin'	len <u>gu</u> so bat
/denpora'/	'time'	den <u>po</u> ra bat
/alkondara'/	'shirt'	al <u>konda</u> ra bat
/errosaxo'/	'rosary'	e <u>rrosa</u> xo bat
<i>Marked root + unmarked suffix</i>		
/leko'+ra/	'place+ALL.SG'	le <u>ku</u> re
/txisto'+ari/	'flute+DAT.SG'	txis <u>tu</u> ai
/lenguso'+antzako/	'cousin+BEN.SG'	len <u>gusuntza</u> ko
/denpora'+an/	'time+IN.SG'	den <u>po</u> ran
/alkondara'+ko/	'shirt+LGEN.SG'	al <u>kondara</u> ko bat
/errosaxo'+ko/	'rosary+LGEN.SG'	e <u>rrosaxu</u> ko bat
<i>Marked root + marked suffix</i>		
/leko'+tik'/	'place+ABL.SG'	le <u>ku</u> tik
/txisto'+akin'/	'flute+COM.PL'	txis <u>tu</u> kin
/lenguso'+ari'/	'cousin+DAT.PL'	len <u>gusu</u> ai
/denpora'+tik'/	'time+ABL.SG'	den <u>po</u> ratik
/alkondara'+ak'/	'shirt+ABS.PL'	al <u>konda</u> rak
/errosaxo'+akin'/	'rosary+COM.PL'	e <u>rrosaxu</u> kin
<i>Unmarked root + marked suffix</i>		
/esko+agas'/	'hand+COM.SG'	es <u>ku</u> as
/txisto+akin'/	'saliva+COM.PL'	txis <u>tu</u> kin
/arroso+ari'/	'breakfast+DAT.PL'	ar <u>mosu</u> ai
/gixon+antzako'/	'man+BEN.PL'	gi <u>xonantza</u> ko
/kartero+akin'/	'mailman+COM.PL'	kar <u>teru</u> kin
/laba+etan'/	'oven+IN.PL'	la <u>be</u> tan

Table 2.1: Accented Words

In contrast to other Vizcayan varieties, the placement of stress in Ondarroa Basque is not determined by the marked morpheme(s) contained in the word. Rather, stress placement obeys the following generalization:

- (2) An accented word is stressed on its penultimate syllable.<sup>6</sup>

Thus, all the accented words in (1) have penultimate stress. This is most clearly seen in paradigms like the one in (3), which contains the uninflected form and several inflected forms of the marked roots /belarri/ 'ear' and /egi/ 'truth'.

- (3) *Accented words have penultimate stress*

	/belarri/ 'ear'	/egi/ 'truth'
<i>Uninflected</i>	be larri	e gi
ABS	be larri xe	e gi xe
ERG	be larri xak	e gi xak
GEN	be larri xan	e gi xan
DAT	be larri xái	e gi xái
BEN	be larrixantza ko	e gixantza ko

As can be seen in the contrast between the uninflected forms and the longer ones below them, stress does not necessarily fall on any specific syllable in the marked root, and as can be seen in the even longer benefactive forms, stress does not even have to fall on the marked morpheme. In all cases, stress is penultimate in the word.

Two more aspects of the pronunciation of accented words need to be taken into account. First, in words longer than two syllables, there is a rise in pitch beginning on the first syllable. Second, in longer words, there is a high pitch plateau beginning on the second syllable and ending in the stressed syllable. Thus, accented words have the following tonal pattern:<sup>7</sup>

<sup>6</sup>A similar pattern can be found in the Kagoshima dialect of Japanese (see Haraguchi 1977). Unlike other dialects of Japanese, the accent introduced by a marked morpheme does not necessarily fall on any syllable in that morpheme. Rather, some of them trigger penultimate stress in the *word*, and others trigger final stress in the word.

<sup>7</sup>This generalization says nothing about monosyllabic accented words. In fact, as shown in appendix A, these do not exist.

(4) *The tonal pattern of accented words*

$$\overline{\sigma} \lfloor \sigma \quad \sigma \lfloor \overline{\sigma \dots} \rfloor \sigma$$

Unaccented words may also contain a pitch drop, but in most environments, they do not. As I show in §2.4 below, in phrase final position, they do contain a pitch drop. Thus, in this environment, and by extension, in isolation, the distinction between accented and unaccented words is neutralized. The following unaccented words are given in phrase initial position, where the contrast with accented words can be seen more clearly:

(5) *Unaccented words in phrase initial position*

/jai+a dakar/	'holiday+ABS.SG has'	ja $\overline{x}$ e rakar
/gixon+a dator/	'man+ABS.SG comes'	gi $\overline{x}$ ona rator
/mendi+an dabil/	'mountain+IN.SG walks'	men $\overline{d}$ ixan dabil
/arreba+an ixena/	'sister+GEN.SG name	a $\overline{r}$ rebi $\overline{n}$ ixena
/mutriku+ko gixona/	'Mutriku+LGEN man'	mu $\overline{t}$ rikuko gixona
/barbero+antzako da/	'barber+BEN.SG is'	ba $\overline{r}$ beruntzako ra
/osasuntzo+a da/	'healthy+ABS.SG is'	o $\overline{s}$ asuntzu re

As can be seen in the contrast between the accented words in (1, 3) and the unaccented words in (5), the latter are characterized by the absence of a pitch drop at the end of the word. Otherwise, their tonal pattern is the same as in accented words. In particular, they also have a rise in pitch at the beginning of the word, and there is also a high pitch plateau beginning on the second syllable and extending to the end of the word. Thus, unaccented words (in non-pitch drop environments) have the following tonal pattern:

(6) *The tonal pattern of unaccented words*

$$\sigma \lfloor \overline{\sigma \dots}$$

In what follows, I take (4) and (6) to be the basic tonal patterns of accented and unaccented words, respectively. Since the only difference between the two types of words is in the presence versus absence of a stressed syllable (i.e. drop in pitch), it is

useful to represent the surface forms of accented words with the acute accent mark (´) on the stressed (i.e. penultimate) syllable, and unaccented words without this mark. Thus, an accented word such as labetan can be represented as *labétan*, and an unaccented word such as gixona can be represented as *gixona*. From now on, I will use this convention, unless more detail is needed, in which case I will use the more detailed representations I have been using so far.

In the following section (§2.3) I provide an analysis of these facts in terms of the metrical grid. As we will see in §2.4, these patterns can be modified at the phrasal level, which will motivate certain extensions and modifications to the analysis introduced in §2.3.

### 2.3 Word Level Stress

As in the rest of this chapter, the theory I adopt in the computation of stress is that of the metrical grid (see, among others, Liberman and Prince 1977, Prince 1983, Halle and Vergnaud 1987, Idsardi 1992, Halle and Idsardi 1995). In particular, I adopt Idsardi's (1992) version of the metrical grid, whose main features were described in §1.3. One of the central ideas of this theory is that many aspects of prosody are the reflection of the metrical grid. In particular, tonal facts such as the ones described in the previous section are analyzed in terms of rules which make explicit reference to the metrical grid. In adopting this hypothesis, I follow Purnell (1997), who successfully applies it to tonal facts in several languages.

There are two main facts that need to be accounted for. First, all words have an initial rise in pitch. Second, accented words contain a final drop in pitch:

- (7) a. *The tonal pattern of accented words*

$$\sigma \boxed{\sigma \dots} \sigma$$

- b. *The tonal pattern of unaccented words*

$$\sigma \boxed{\sigma \dots}$$

In order to account for these facts, I propose that Ondarroa Basque has the stress rules in (8):

(8) *Stress rules for line 0*

a. Project a grid element for each syllable head.

b. Edge-marking: LRL.

$$\emptyset \rightarrow ( / \#* \_$$

c. Edge-marking: RLR (only in words containing a marked morpheme).<sup>8</sup>

$$\emptyset \rightarrow ) / * \_ * \#$$

d. Heads: rightmost.

These rules derive the following metrical grids for both types of words:

(9) a. *Accented words*      b. *Unaccented words*

*    line 1	*    line 1
*(...*)*    line 0	*(...)**    line 0
$\sigma \sigma \dots \sigma \sigma$	$\sigma \sigma \dots \sigma \sigma$

In both types of words, LRL creates a foot on line 0 beginning on the second syllable. The only difference between accented and unaccented words is that, due to RLR, which only applies in the former, this foot ends on the penultimate syllable in accented words. RLR does not apply in unaccented words, so their foot ends on the last syllable.

Given these metrical representations, the tonal patterns in (7) are derived as follows: a high tone is linked to all the elements inside the only foot created in line 0, and a low tone is linked to the ones outside the foot. The tones rules necessary for this result are those in (10). As schematized in (11), these rules derive the correct representations for both accented and unaccented words.

(10) *Tone Rules*a. *H-insertion*

$$\emptyset \rightarrow \begin{array}{c} * \text{ line 1} \\ \text{H} / * \text{ line 0} \\ | \\ \_ \end{array}$$

b. *H-spread*

$$\begin{array}{c} ** \rightarrow ** \\ | \quad \vee \\ \text{H} \quad \text{H} \end{array}$$

c. *Default low tone*

$$\begin{array}{c} * \rightarrow * \text{ line 0} \\ | \\ \text{L} \end{array}$$

<sup>8</sup>There are certain details in the structural description that are crucial. Specifically, the right parenthesis can only be inserted if the word contains two or more grid elements. Evidence for this aspect of this rule is given in appendix A.

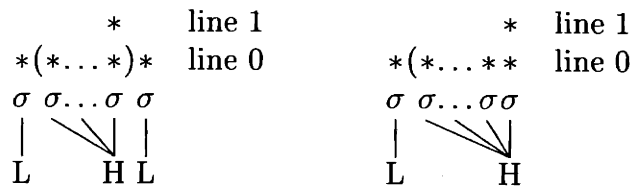
(11) a. *Accented words*                      b. *Unaccented words*

Some examples of accented and unaccented words are given in (12) and (13), respectively.

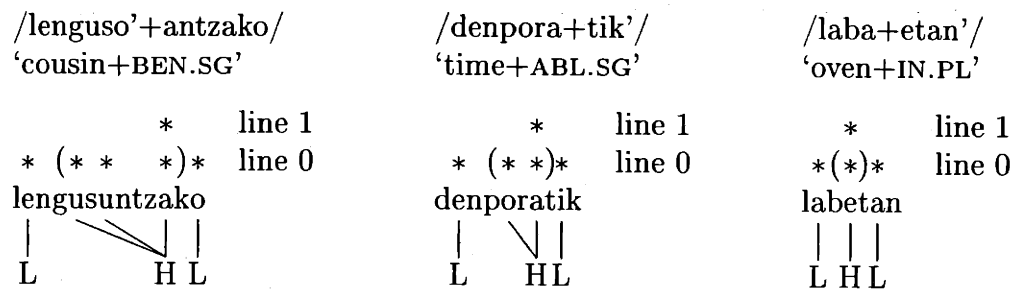
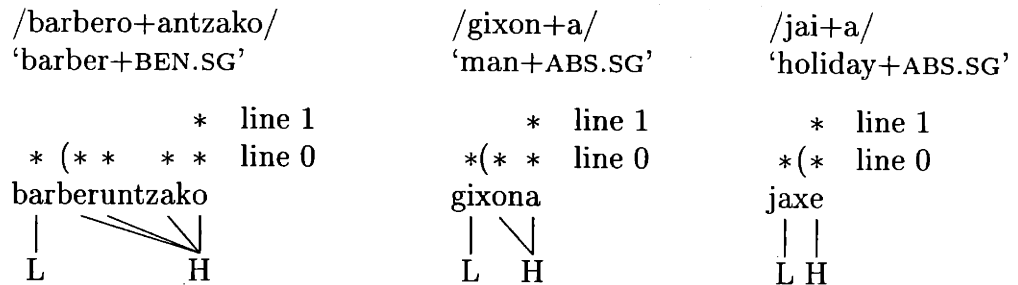
(12) *Accented words*(13) *Unaccented words*

Finally, we need the following parenthesis deletion rule:

## (14) ) ( → )

This rule is only relevant in bisyllabic accented words, where both edge-markings in (8), LRL and RLR, place a left and a right parenthesis between the only two grid marks on line 0. For instance, for the uninflected marked root /leko'/ 'place', the stress rules would derive the grid  $leko$ . This grid would not derive the right tonal pattern for this word, which is  $leko$ . (14) deletes the left parenthesis, giving the correct result:

- (15) \* line 1  
 \*)\* line 0  
 leko  
 | |  
 H L

In the following section, I show that the metrical grid created at the word level is modified at the phrase level in certain positions.

## 2.4 Phrase Level Stress

At the phrase level, the grids created at the word level are modified in two different ways. First, the initial rise in pitch derived at the word level is only maintained in phrase initial position. Second, there is a drop in pitch at the end of the phrase, whether or not it coincides with an accented word. Consider the following example, in which two unaccented words are joined into a phrase. (16a) contains the predicted output given the rules introduced in the previous section, and (16b) the actual output.

- (16) /gixon/ /andi+a/  
 'man' 'big+ABS.SG'

a. *Word level rules*

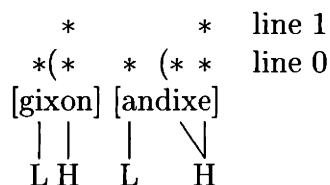

b. *Actual output:* gi|xon andi|xe

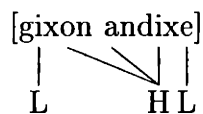

Thus, it is clear that, at the phrase level, there are some stress rules that modify the structure created at the word level.

First, the second word in (16), *andixe* does not have the expected initial low tone. The first word, *gixon*, however, does have the expected initial low tone. In terms of the metrical grid, this must mean that the left parenthesis in the second word is

deleted. This can be stated naturally as a rule which deletes a left parenthesis when preceded by another left parenthesis:<sup>9</sup>

(17) *Left parenthesis deletion at the phrase level*

$( \rightarrow \emptyset / ( X \_$

where  $X$  contains no parenthesis.

The addition of this rule results in a surface representation for (16) which is closer to the actual one:

(18) a. /gixon/ /andi+a/  
'man' 'big.ABS.SG'

*Word level rules*

\* \* line 1  
\*( \* \* (\* \* line 0  
[gixon] [andixe]

*Left parenthesis deletion*

\* \* line 1  
\*( \* \* \* \* line 0  
[gixon andixe]  
| |  
L H

b. *Actual output:* gi|xon andi|xe

[gixon andixe]  
| | |  
L H L

The phrase contains two left parenthesis inserted at the word level, one in each word (cf. 16a). At the phrase level, (17) deletes the second one, resulting in (18a). The direct effect of the deletion rule is that the phrase contains only one line 0 foot, which is reflected in that only one vowel in the phrase projects to line 1. Given the tone rules introduced in the previous section (cf. 10), this correctly derives the fact that only the first word in the phrase contains a rise in pitch.

However, we still need to account for the fact that, as shown in (18b), a final drop in pitch ('accent') appears beginning on the penultimate syllable, even though it does

<sup>9</sup>As a result of this rule, most left parentheses created at the word level are deleted at the phrase level. The data presented so far could be analyzed in a simpler way by simply having a rule inserting a parenthesis phrase initially, rather than having both an insertion rule at the word level and a deletion rule at the phrase level. However, as I show below, there are other positions apart from phrase initially in which left parentheses are kept. Having a single parenthesis rule at the phrase level would thus not be sufficient. As will be shown below, the two rules proposed here capture all the relevant facts.

not belong to an accented word. Given the tone rules introduced in the previous section, this must mean that a right parenthesis is inserted to the left of the last grid element in the phrase:<sup>10</sup>

(19) Phrase level edge-marking: RLR.<sup>11</sup>

$$\emptyset \rightarrow ) / * \_ * ] \text{ line 0}$$

$$\quad \quad \quad |$$

$$\quad \quad \quad \text{CV}$$

The addition of these two phrase level rules (17&19) results in the correct representation for (16):

(20) /gixon/ /andi+a/  
'man' 'big.ABS.SG'

<i>Word level rules</i>	<i>Phrase level rules</i>
$\begin{array}{ccc} * & * & \text{line 1} \\ *( * & * ( * * & \text{line 0} \\ \text{[gixon]} & \text{[andixe]} & \end{array}$	$\rightarrow \begin{array}{ccc} * & * & \text{line 1} \\ *( * & * * ) * & \text{line 0} \\ \text{[gixon andixe]} & & \\   & \diagdown &   &   \\ \text{L} & & \text{H} & \text{L} \end{array}$

In order to obtain the correct result, the tone rules (cf. 10) must apply only at the end of the phrase level, i.e. after both word and phrase level stress rules have applied. If the tone rules were also allowed to apply at the word level, we would not obtain the correct result. This is simply a consequence of the hypothesis that the metrical grid is the main element in explaining the tonal patterns of words and phrases in Ondarroa Basque. The surface distribution of tones is simply a reflection of the metrical grid, which means that tone rules apply after all rules constructing the metrical grid have applied.

To summarize so far, I have argued that the following stress rules are needed for the word and phrase levels:

<sup>10</sup>Note that there is an additional condition on this rule: the vowel corresponding to the last grid element must be preceded by a consonant. This condition is discussed in appendix B.

<sup>11</sup>The fact that the vowel linked to the last grid element must be preceded by a consonant is discussed in appendix B.



parenthesis. Thus, when a phrase contains two unaccented words, the left parenthesis on the second word is deleted, but not the one in the first word. In the data we have seen so far, this means that only the left parenthesis on the first word is kept at the phrase level. Having two rules (parenthesis insertion at the word level and deletion at the phrase level) might seem redundant, since the same result could be obtained by having a rule inserting a left parenthesis on the phrase initial word. However, there are further data that show that the analysis proposed here is correct. This particular way of understanding the ‘loss’ of the initial low tone in non-phrase initial words makes the prediction that the left parenthesis of a given word is not deleted when the word is preceded by an accented word. As is known from the literature on Basque phonology cited in the introduction, this prediction is correct, as exemplified in the following cases:<sup>12</sup>

- (24) *Accented + unaccented*: /belarri’/ /andi+a/  
   ‘ear’                   ‘big.ABS.SG’

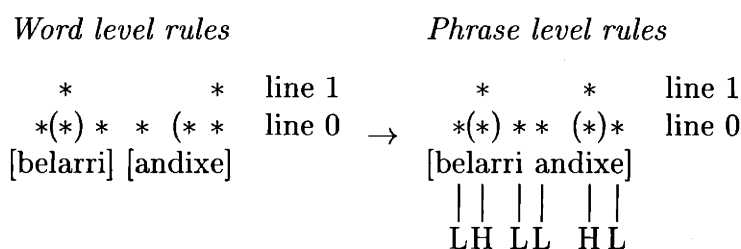

- (25) *Accented + accented*: /belarri’/ /andi+ak’/  
   ‘ear’                   ‘big+ABS.PL’

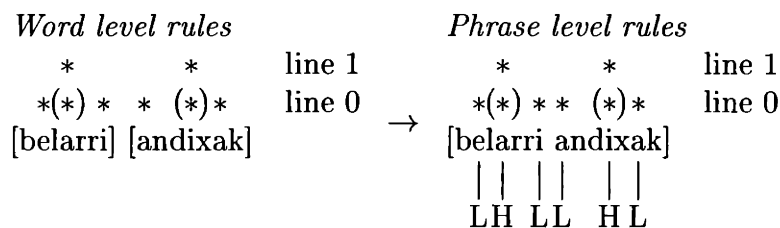

What distinguishes these cases from the ones we saw before is that there is a right parenthesis between the two left parentheses, due to the fact that the first word is

<sup>12</sup>The idea that the initial low tone (i.e. initial left parenthesis) that appears in some words is the result of two rules (a word level one and a phrase level one) was first proposed by Hualde 1991a. Although the rules he proposed were stated in terms of tones, rather than stress, the proposal made here is simply a translation of his insight into the formalism of the metrical grid. For a different view, see, among others, Elordieta 1997a.





A question that arises at this point is whether there is projection to higher lines at the phrase level, especially in cases like (29b), where more than one vowel projects to line 1. When a phrase contains more than one stress, it can be pronounced in different ways. Specifically, the high tone of one of the accents is pronounced at a higher pitch than the other ones. Although any of the accents can in principle be pronounced at a higher pitch, there is a neutral pronunciation in which the first accent is higher (see Elordieta 1997a for details). Thus, in its neutral pronunciation, the leftmost accent is more prominent than the other ones, i.e. the vowel corresponding to this accent projects a higher column in the grid than the other accented vowels. Given the metrical analysis developed so far, this means that we need additional rules that project the leftmost line 1 grid element onto line 2.

To summarize so far, we need the following rules to account for the facts examined. First, at the word level, the stress rules in (21) above apply. At the phrase level, the stress rules in (30) below apply, giving phrase level prominence. The new rule which determines phrase prominence is (30bii). The tone rules in (10), repeated below as (31), apply at the phrase level, after all the stress rules.

(30) *Phrase Level Stress*

- |   |   |
|---|---|
| <p>a. <i>Line 0:</i></p> <p>i. Project a grid element<br/>for each syllable head.</p> <p>ii. Left parenthesis deletion:<br/>( <math>\rightarrow</math> <math>\emptyset</math> / ( X _<br/>X contains no parenthesis.</p> <p>iii. Edge-marking: RLR:<br/><math>\emptyset \rightarrow ) / * \_ * ]</math><br/>                                   <br/>                                  CV</p> <p>iv. ) ( <math>\rightarrow</math> )<sup>13</sup></p> <p>v. Heads: rightmost.</p> | <p>b. <i>Line 1:</i></p> <p>i. Edge-marking: LLL:<sup>14</sup><br/><math>\emptyset \rightarrow ( / \# \_ *</math></p> <p>ii. Heads: leftmost.</p> |
|---|---|

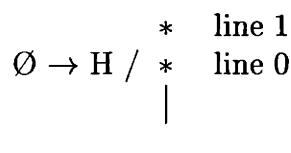
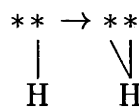
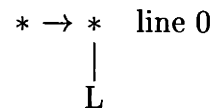
(31) *Tone Rules*a. *H-insertion*b. *H-spread*c. *Default low tone*

(32-32b) below contain full derivations for the two examples in (29).

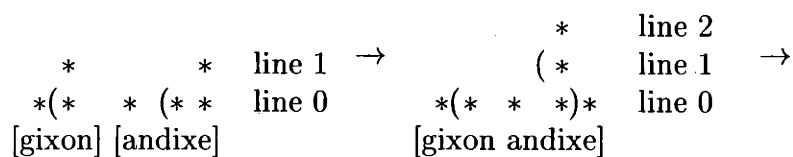
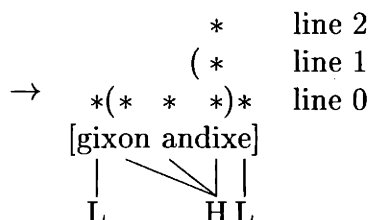
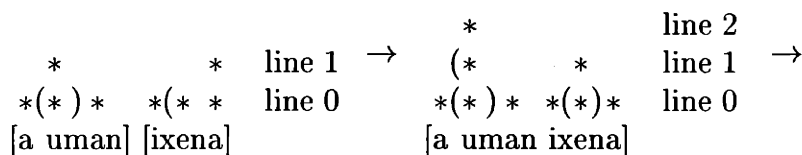
(32) a. *Unaccented + Unaccented*: /gixon/ /andi+a/  
'man' 'big+ABS.SG'*Word level stress (21)**Phrase level stress (30)**Tone rules (31)*b. *Accented + Unaccented*: /auma'+an/ /ixen+a/  
'grandmother+GEN.SG' 'name+ABS.SG'*Word level stress (21)**Phrase level stress (30)*

<sup>13</sup>This rule was motivated in §2.3 to account for bisyllabic accented words. However, it is also necessary in order to account for bisyllabic phrases, in which both a left and a right parenthesis is inserted between the two grid elements on line 0. By applying this rule at the phrase level, it takes care of both cases.

<sup>14</sup>This rule ensures that there is a foot in line 1. If there were not, there could be no projection to line 2.

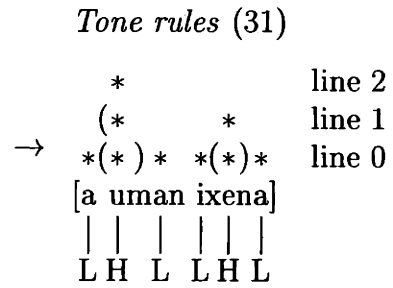

## 2.5 Conclusion

To conclude, the surface tonal patterns of words and phrases in Ondarroa Basque are accounted for in terms of (i) metrical rules which apply at the word and phrase levels, and (ii) rules of tone insertion and spreading which apply after all metrical rules have applied.

## Appendix A: Monosyllabic Words and Underlying Tones

In this chapter, we saw that certain words have penultimate accent. In the analysis proposed, this is due to RLR edge-marking applying at the word level. An interesting question that arises is what happens when an accented word only has one syllable, since, in this case, there is no penultimate syllable where accent could fall. In this section, I show that monosyllabic words in fact cannot be accented, that is, I show that there are no monosyllabic accented words, and that this is not an accidental gap. Furthermore, I show that the framework adopted here can readily account for this fact. In §A.2, I argue that these facts pose a problem for analyses which employ underlying tones, rather than the metrical grid, in order to explain the surface tonal patterns in this language (cf. Hualde 1991a).

### A.1 Stress in Monosyllabic Words

There are two roots that can be used to show that there are no accented monosyllabic words in Ondarroa Basque: /mai'/ 'table', and /plai'/ 'beach'. In what follows, the arguments are based on /mai'/, but it should be noted that the facts are exactly the same for /plai'/. First, we need to show that these roots are indeed marked, i.e. we need to show that words that contain them are accented. In all the following examples, there is a word which contains the root /mai'/ and some suffix.

- (33) a. /mai'+a/       $\overline{\text{ma}}\underline{\text{x}}\text{e}$   
           'table+ABS.SG'
- b. /mai'+ak'/     $\overline{\text{ma}}\underline{\text{x}}\text{ak}$   
           'table+ABS.PL'
- c. /mai'+ko/      $\overline{\text{ma}}\underline{\text{i}}\underline{\text{k}}\text{o}$   
           'table+LGEN.SG'
- d. /mai'+antzako'/  $\underline{\text{ma}}\underline{\text{x}}\underline{\text{antza}}\underline{\text{k}}\text{o}$   
           'table+BEN.SG'

- (34) a. /ori/            /mai'+a/            ōri māxe  
           'that.ABS.SG' 'table+ABS.SG'
- b. /mai'+a/            /da/ māxe ra  
           'table+ABS.SG' 'is'
- c. /mai'+ko/            /anka+ak'/    māīko an̄kak  
           'table+LGEN.SG' 'leg+ABS.PL'

The examples in (33, 34) show that /mai'/ is indeed a marked root. As with any other marked root, any word containing /mai'/ and a marked or unmarked suffix is accented on the penultimate syllable (cf. 33).<sup>15</sup> Furthermore, as shown in (34), this accent is kept in any position within a phrase. Thus, it is clear that /mai'/ is a marked root.

However, when /mai'/ is unsuffixed, the pattern that emerges is quite different. Consider the following examples:

- (35) a. /mai'/ /bat+ntzako/ māī batenzāko  
           'table' 'one+BEN'
- b. /iru/ /mai'/    īru māī  
           'three' 'table.ABS'
- c. /iru/ /mai'/ /andi/    īru māī an̄di  
           'three' 'table' 'big.ABS'

In all these examples, the tonal patterns indicate that unsuffixed /mai'/ is *not* accented, since it does not contain a drop in pitch. This is seen more clearly when compared to unmarked monosyllabic roots, such as /bar/ 'bar' in the same contexts:

- (36) a. /bar/ /bat+ntzako/ bar̄ batenzāko  
           'bar' 'one+BEN'

<sup>15</sup>Note that the two vowels in the root /mai'/ are realized as a diphthong (*māī*), so that the root corresponds to only one syllable. Whenever it is followed by a vowel (e.g. /mai'+ak/ in 33b), an epenthetic *x* (a voiceless prepalatal fricative [š]) is inserted, as is always the case in the environment *i\_\_V*. Finally, in this environment (i.e. *V\_\_palatal C*), the glide *i* is optionally deleted. In all the examples where this deletion rule can apply, I give the form in which it applies. These are all regular rules in Ondarroa Basque (and in many other dialects). See Hualde 1991a (§2) for details.

- b. /iru/ /bar/    i̯ru̯ bar  
 ‘three’ ‘bar.ABS’
- c. /iru/ /bar/ /andi/    i̯ru̯ bar an̯di  
 ‘three’ ‘bar’ ‘big.ABS’

Moreover, just as with unaccented words, unsuffixed /mai’/ has phrase accent when it is in the right position within the phrase (i.e. penultimate):

- (37) a. /mai’/ /bat/    maĩ̯ bat  
 ‘table’ ‘one.ABS’
- b. /bar/ /bat/    ba̯r bat  
 ‘bar’ ‘one.ABS’

The necessary conclusion is that a word containing a marked monosyllabic root is accented only if the word containing it has more than one syllable.

Intuitively, this fact seems rather natural, given the general properties of stress placement in Ondarroa Basque. Since stress is penultimate, and there is no penultimate syllable in monosyllabic words, it follows that there can be no monosyllabic accented words. In order to make this intuition more precise, we need to take a detailed look at the rule that is ultimately responsible for penultimate accent: RLR at the word level. This rule inserts a right parenthesis to the left of the rightmost element in line 0. I propose that it is formalized as follows:

- (38) *RLR at the word level*  
 $\emptyset \rightarrow ) / *\_ * \#$

Given this formulation of RLR, it cannot apply to unsuffixed /mai’/, since it contains only one grid mark on line 0. Thus, after all word level metrical rules (21) apply, it has the following metrical grid:

- (39)        \*( line 0  
               [mai]

This correctly predicts that this word behaves exactly as an unaccented word, as shown in (40). Note that, at the word level, there is a left parenthesis on *mai* which does not form any foot. At the phrase level, this left parenthesis groups grid marks belonging to words following it in (40a), or is deleted by phrase rules (rule 30ai in 40b,c, and 30aiii in 40d).

- (40) a. /mai'/ /bat+ntzako/  
 'table' 'one+BEN'

*Word level stress* (21)

*Phrase level stress* (30)

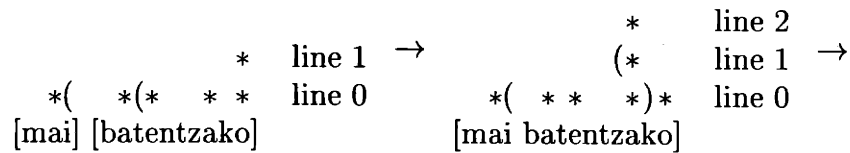

*Tone rules* (31)

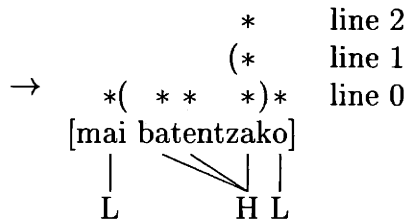

- b. /iru/ /mai'/  
 'three' 'table.ABS'

*Word level stress* (21)

*Phrase level stress* (30)

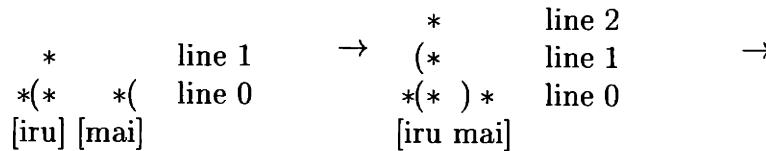

*Tone rules* (31)

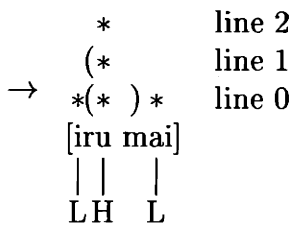

- c. /iru/ /mai'/ /andi/  
'three' 'table' 'big.ABS'

*Word level stress* (21)

*Phrase level stress* (30)

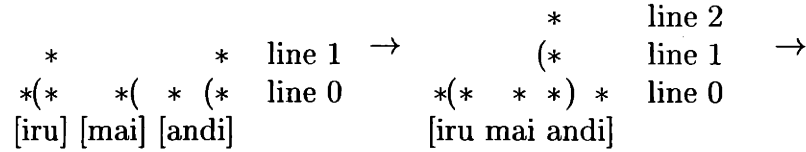

*Tone rules* (31)

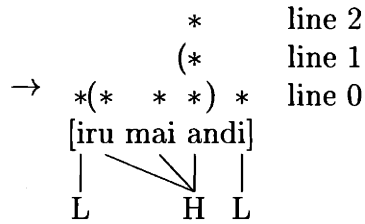

- d. /mai'/ /bat/  
'table' 'one.ABS'

*Word level stress* (21)

*Phrase level stress* (30)

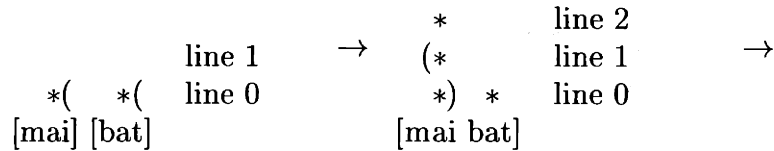

*Tone rules* (31)

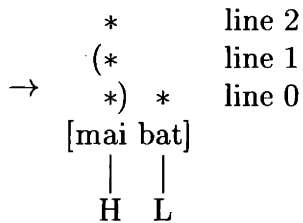

This result is possible due to the fact that the analysis is based on the hypothesis that the tonal patterns of words in Ondarroa Basque are the phonetic realization of stress. As noted above, the intuitive idea is that stress is penultimate, and, since monosyllabic words do not have a penultimate syllable, they cannot be stressed. These data also bring out an important part of the analysis. What distinguishes accented words from unaccented words is that they are lexically specified to undergo RLR at the word level. That is, they are not lexically specified with underlying tones or accents. If they were, monosyllabic accented words would be expected to occur.

By treating the lexical idiosyncrasy of accented words in terms of a metrical rule that applies only to them, we are able to derive the fact that there are no monosyllabic accented words.

In the remainder of this section, I compare this analysis to previous ones in the light of these data. Specifically, I argue that previous analyses which posit underlying tones in Ondarra Basque cannot handle the data introduced in this section in a natural way. First, in §A.2, I discuss Hualde's (1991a) tonal analysis, in which stress plays no role in accounting for the surface tonal patterns of words in the pitch accent dialects of Basque. Although evidence has already been presented in the literature that a metrical analysis is to be preferred (see, in particular Hualde 1991b and Hualde and Bilbao 1993), the data discussed in this section provide further evidence that this is the case.

## A.2 Hualde 1991a

In the first extensive analysis of Basque prosody in the generative literature, Hualde (1991a, Ch. 6) develops an analysis of the pitch accent dialects of Basque which is completely independent of stress. The basic idea of the analysis is that accented words have underlying tones, whereas unaccented ones do not, and that this is what is ultimately responsible for the differences in their surface tonal patterns. In the specific case of Ondarra Basque (§6.1.3), he proposes that marked morphemes contain an unlinked low tone in their lexical representation, as exemplified in (41) for several roots and affixes.

### (41) *Hualde 1991a: Marked Morphemes*

#### a. *Marked Roots*

leko	'place'	lenguso	'cousin'	alkondara	shirt'
L		L		L	

#### b. *Marked Affixes*

-tik	'ABL.SG'	-antzako	'BEN.PL'	-ak	'ABS.PL'
L		L		L	

The surface tonal patterns are obtained through the following rules:<sup>16</sup>

(42) *Hualde 1991a: Tone Rules*

- a. The initial syllable is marked extratonal.
- b. A high tone is inserted to the left of any tone already present.
- c. Left-to-right high tone spreading.<sup>17</sup>
- d. Remove initial extratonicity.
- e. Associate a low tone to any toneless Tone Bearing Unit.

These rules derive the correct tonal patterns in words with more than two syllables:

(43) *Marked root + unmarked suffix: /alkondara'+ko/ 'shirt+LGEN.SG'*

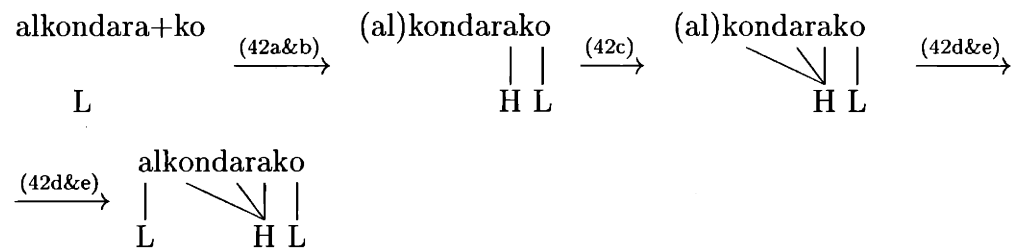

(44) *Unmarked root + marked suffix: /gixon+antzako' / 'man+BEN.PL'*

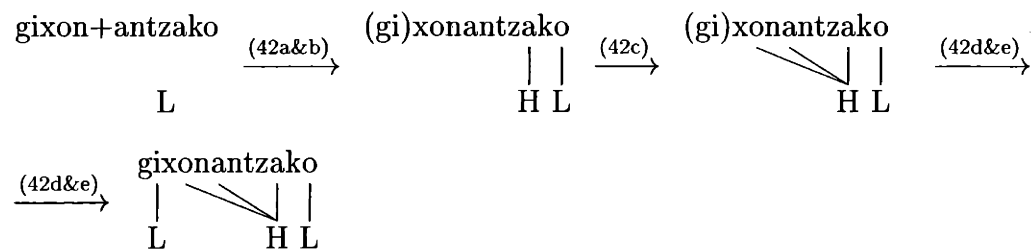

(45) *Unmarked root + unmarked suffix: /gixon+a/ 'man+BEN.PL'*

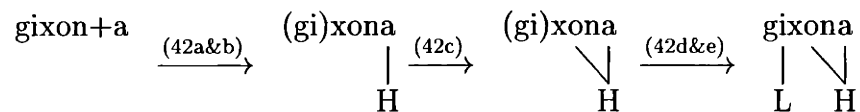

<sup>16</sup>I have not included here words containing more than one marked morpheme, which, in this analysis, would contain more than one underlying low tone. For these cases, Hualde proposes that a rule motivated by the OCP deletes all underlying low tones except one.

<sup>17</sup>In fact, in order to get the facts right in all the dialects he discusses, Hualde posits bidirectional spreading: high tones spread to the left, and low tones spread to the right. Since there is no need for rightward low tone spreading in Ondarrao Basque (the only relevant tone is first associated to the last syllable), I have ignored this aspect of Hualde's analysis here.

In bisyllabic accented words, the derivation is a bit different. Before initial extratonicity is removed, the high tone remains unlinked. After extratonicity is removed, this high tone is linked to the initial vowel, so that there is no need to insert the default low tone (42e):

(46) *Bisyllabic accented word: /jone'/ 'Jone'*

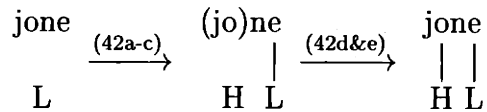

Consider now monosyllabic words in this analysis:

(47) *Monosyllabic word containing a marked morpheme: /mai'/ 'table'*

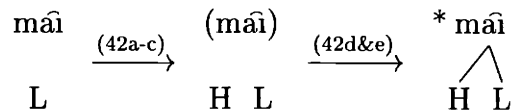

Given that, as we saw in the previous section, the root /mai'/ is marked, it is specified as containing an unlinked underlying tone in this analysis. Since the first (and only) syllable in the word is extratonal, no tone association occurs, and two unlinked tones (H and L) remain. After extratonicity is removed, the two tones are linked to the only syllable in the word, as shown in (47). This wrongly predicts that the uninflected root surfaces as an accented word.

The main problem with this analysis is that marked morphemes are lexically specified as containing a low tone, which wrongly predicts that all words containing marked morphemes are accented. This problem does not arise in the metrical analysis defended in this thesis, since the crucial property that marked morphemes have is that they trigger the application of a specific rule. If, as in the case of monosyllabic words, the structural description of the rule is not satisfied, it does not apply.

## Appendix B: Stress, Vowel Deletion and Cyclicity

A crucial feature of the analysis of stress in Ondarroa Basque developed so far is that stress rules apply cyclically: first, certain rules apply to words, and then other rules apply to phrases. However, there are certain facts having to do with vowel deletion which seem to contradict this hypothesis. In fact, this contradiction has been used in Hualde 1996 to argue against cyclic rule application, and, as a consequence, against derivational phonology.<sup>18</sup> In this section, I argue that a more comprehensive look at the Ondarroa Basque data in fact shows that there is no contradiction, and, hence, no argument against cyclic rule application or derivational phonology. Furthermore, the data examined in this section also justifies certain small changes in the stress rules proposed so far.

Phonological processes occurring in Basque vowel clusters are well-known for their complexity and substantial dialect variation. As argued for in de Rijk 1970 and Hualde 1991a (§2), this complexity and variation can be explained in terms of simple rules which are ordered in different ways in different dialects. In this section, I discuss one such process as it applies in Ondarroa Basque, vowel deletion, and its interaction with stress assignment.

In Ondarroa Basque, the non-high unrounded vowels *a* and *e* are deleted when preceded by a high vowel:

(48) *Vowel Deletion* (Hualde 1991a, §2.5.2.1)

$$\left[ \begin{array}{c} \text{V} \\ -\text{high} \\ -\text{round} \end{array} \right] \rightarrow \emptyset / \left[ \begin{array}{c} \text{V} \\ +\text{high} \end{array} \right] \_$$

Vowel deletion is exemplified in the following:

- (49) a. /gixon+a/ → gixona  $\xrightarrow{(48)}$  N.A.  
           ‘man+ABS.SG’
- b. /on+en'+a/ → onena  $\xrightarrow{(48)}$  N.A.  
           ‘good+SUP+ABS.SG’

<sup>18</sup>A similar argument is made in Hualde 1999b, based on these facts and others taken from several dialects of Basque.

- (50) a. /alaba+a/ → alabia <sup>(48)</sup>→ alabi  
           'daughter+ABS.SG'
- b. /arbola'+a/ → arbolia <sup>(48)</sup>→ arboli  
           'tree+ABS.SG'
- (51) a. /etxe+a/ → etxia <sup>(48)</sup>→ etxi  
           'house+ABS.SG'
- b. /beste'+a/ → bestia <sup>(48)</sup>→ besti
- (52) a. /asto+a/ → astua <sup>(48)</sup>→ astu  
           'donkey+a'
- b. /leko+a/ → lekua <sup>(48)</sup>→ leku  
           'place+ABS.SG'

All these examples contain the suffix *-a*, which is deleted by (48) when preceded by a high vowel. In (49), vowel deletion does not apply, since *a* is not preceded by another vowel. In (50-52), the suffix is preceded by a high vowel, and deletion applies. Note that, in all these examples, the vowel triggering deletion becomes high by certain rules that raise low and mid vowels in hiatus contexts. The exact formulation of these rules is not important for present purposes, and I will ignore it for ease of exposition (see de Rijk 1970 and Hualde 1991a, §2, for details).

Hualde 1996 argues that the interaction of vowel deletion and stress assignment provides evidence against cyclic rule application. His basic observation is that word level and phrase level stress appear to interact differently with vowel deletion, and in a manner inconsistent with the hypothesis that rules with smaller domains apply before rules with bigger domains. Recall that, as we saw in the previous sections, word level stress in Ondarroa Basque falls on the penultimate syllable in accented words, and that unaccented words may be stressed due to phrase level stress, which makes the penultimate syllable in a phrase stressed. Consider word level stress first. As shown in the following examples, accented words have penultimate stress when the final vowel is deleted:

(53) *Stress and vowel deletion in accented words: penultimate stress*

a. /arbola'+a/ → arbóli

'tree+ABS.SG'

b. /beste'+a/ → bésti

'other+ABS.SG'

c. /leko'+a/ → léku

'place+ABS.SG'

Given that word level stress assigns penultimate stress, these data show that word level stress applies after vowel deletion:

## (54) Word level stress → Vowel deletion

A different conclusion is reached when we examine the interaction of vowel deletion with phrase level stress:

(55) *Stress and vowel deletion in unaccented words: final stress*

a. /alaba+a/ → alabí

'daughter+ABS.SG'

b. /etxe+a/ → etxí

'house+ABS.SG'

c. /asto+a/ → astú

'donkey+ABS.SG'

In this case, the result is final stress. Since phrase level stress assigns penultimate stress, the conclusion is that phrase level stress precedes vowel deletion:

## (56) Vowel deletion → Phrase level stress

The necessary conclusion from (54) and (56) is that phrase level stress precedes word level stress. However, this order contradicts the ordering of stress rules assumed in the previous sections. In fact, it contradicts the standard hypothesis of cyclic rule application in Generative Phonology: rules that apply to smaller domains (e.g.

words) must apply before those that apply to larger domains (e.g. phrases). Thus, as argued by Hualde, unless an alternative account is provided, the data discussed above constitute an argument against the cyclicity hypothesis.

A crucial assumption in Hualde's argument is that word level and phrase level stress rules both assign penultimate stress in all contexts, including those in which the relevant domain ends in a vowel cluster. For instance, for the unaccented word *etxi* (55b), the assumption is that before vowel deletion, phrase level stress results in penultimate stress (*etxia*). Similarly, the assumption that word level stress always assigns penultimate stress motivates the ordering of word level stress after vowel deletion. If it applied before, the result would be final stress. However, the assumption that both word and phrase level stress assign penultimate stress in final VV contexts is in fact wrong. Examples showing this are not easy to find, due precisely to the rule of vowel deletion discussed above and other rules that modify vowel clusters.<sup>19</sup> In particular, we need to find cases in which the first vowel in the VV cluster is not high when vowel deletion applies.

A quite productive case is provided by the allative suffix *-ra*, when following a V-final stem. As in many other dialects, *r* is deleted when preceded by a non-high vowel and followed by a vowel.<sup>20</sup> Vowel clusters resulting from this rule are not subject to vowel deletion, since the first vowel is not high, and by hypothesis, the rule applies after all the relevant rules which apply to vowel clusters and which could result in the first vowel being high (see the discussion around 48). Consider now the interaction of word level stress with *r*-deletion. The result, as exemplified below, is antepenultimate, rather than penultimate, stress.<sup>21</sup>

<sup>19</sup>Other relevant rules include one which inserts *x* between a high vowel and a vowel (see footnote 15), and another vowel deletion rule which affects *a* when followed by another vowel. See Hualde 1991a (§2) for details.

<sup>20</sup>In general, the consonants *r*, *b*, *d* and *g* are deleted intervocalically. The exact context where deletion applies vary depending on the specific consonant, and deletion is optional in some cases. In the case of the allative suffix *-ra* deletion is obligatory.

<sup>21</sup>Not all final VV clusters yield word level antepenultimate stress. For instance, this is not the case when the VV cluster occurs morpheme internally, as in /*idea*'/ → *idéa*. I assume that the rule that is responsible for antepenultimate stress (cf. 60) does not apply morpheme internally. Another case is provided by the commitative suffix /*gas*'/. Since *g* is deleted between vowels (see footnote 20), when this suffix is attached to a stem ending in a vowel, the resulting surface form has a final vowel

(57) *Word level stress in final VV clusters: antepenultimate stress*

- a. /beste'+ra/  $\xrightarrow{r\text{-del.}}$  bestea  $\xrightarrow{\text{Word st.}}$  béstea  
 'other+ALL.SG'
- b. /bilbo'+ra/  $\xrightarrow{r\text{-del.}}$  bilboa  $\xrightarrow{\text{Word st.}}$  bílboa  
 'Bilbao+ALL.SG'

This shows that words ending in final VV clusters in which the second vowel is deleted do not provide any evidence for the ordering of vowel deletion and word level stress. If the order were as posited in (54), vowel deletion before word level stress, the result would be penultimate stress, as discussed above. If, on the other hand, the order were word level stress before vowel deletion, the result would *also* be penultimate stress: before vowel deletion, the word ends in a VV cluster, so antepenultimate stress is assigned. The result after vowel deletion is penultimate stress, as desired.

Thus, we can posit the following order of rules, which is compatible with cyclic rule application:

(58) *Word level stress* → *Phrase level stress* → *Vowel deletion*

This order can account for all the relevant data. In particular, the fact that vowel deletion follows word level stress does not result in final word level stress, since, precisely in the contexts where vowel deletion applies, word level stress is antepenultimate. The final result in these cases is penultimate stress, due to vowel deletion. For instance, the derivation for the accented word *bésti* in (53b) would be as follows:

- (59) /beste'+a/ → bestia  $\xrightarrow{\text{Word st.}}$  béstia  $\xrightarrow{(48)}$  bésti  
 'other+ABS.SG'

In order to account for the fact that, in final VV contexts, word level stress is assigned to the antepenultimate vowel, rather than the penultimate one, I propose that a word level rule makes the final vowel in this context unstressable, i.e. it deletes

---

cluster: e.g. /inaki+gas/ → *Iñakías*. The result in this case is penultimate, not antepenultimate, stress. I assume that *g*-deletion, unlike *r*-deletion, applies after word level stress is assigned.

the line 0 grid mark corresponding to this vowel. This follows Halle's (1998§6) analysis of similar facts in English.<sup>22</sup> Thus, in this context, the final vowel does not 'count' for word level stress rules, resulting in antepenultimate, rather than penultimate stress. This rule is stated in (60), where the fact that a grid mark is deleted is represented as with a dot '.' in place of the grid mark:<sup>23</sup>

$$(60) \quad * \rightarrow . / \quad \begin{array}{c} \_ \# \\ | \\ V+V \end{array} \quad \text{line 0}$$

The metrical grid for an example like (57a) is then as follows:

$$(61) \quad /beste+ra/ \rightarrow b\acute{e}stea$$

'other+ALL.SG'

*	line 1
*)*	line 0
bestea	

Another important question we have not dealt with so far is what the interaction is between phrase level stress and vowel clusters in final position. Recall that part of Hualde's argument is that phrase level stress must precede vowel deletion because, in contexts where the final vowel is deleted, the result is final, rather than penultimate, stress. This argument rests on the assumption that, in final VV clusters, penultimate stress is assigned at the phrase level. As with word level stress, this assumption is in fact incorrect. Phrase stress is final in these contexts. Nevertheless, as I argue below, we still need the ordering posited by Hualde: vowel deletion applies after phrase level stress.

A context where we can verify this is the same as the one we used for word level stress above: the suffix *-ra* when preceded by a non-high vowel final stem. As shown above, in this context, the *r* deletes, and the resulting final VV cluster remains on the surface. In this case, phrase level stress assigns *final*, rather than penultimate, stress:

<sup>22</sup>In particular, Halle considers several English words in which stress is one syllable to the left of what is expected given regular rules. He proposes that these words are subject to a rule that renders the final vowel in them unstressable.

<sup>23</sup>As noted in footnote 21, this rule does not apply morpheme internally.

(62) *Phrase level stress in final VV clusters: final stress*

- a. /etxe+ra/  $\xrightarrow{r\text{-del.}}$  etxea  $\xrightarrow{\text{Ph. st.}}$  etxeá  
 ‘house+ALL.SG’
- b. /paris+ra/  $\rightarrow$  pariserá  $\xrightarrow{r\text{-del.}}$  pariseá  $\xrightarrow{\text{Ph. st.}}$  pariseá<sup>24</sup>  
 ‘Paris+ALL’

Even though, in these cases, stress is not penultimate, as expected, but final, we still need to assume the ordering of phrase level stress before vowel deletion. In the relevant cases, i.e. where the second vowel of a final VV cluster is deleted, final stress can only be the result of this ordering. If vowel deletion applied before phrase level stress, stress would be expected to be penultimate. This is exemplified for the word *etxi* below:

(63) \*Vowel deletion  $\rightarrow$  Phrase level stress

- /etxe+a/  $\rightarrow$  etxia  $\xrightarrow{(48)}$  etxi  $\xrightarrow{\text{Ph. st.}}$  \*étxi  
 ‘house+ABS.SG’

In order to implement the fact that in word final vowel clusters phrase level stress is final, we need to modify one of the phrase level rules discussed in §2.4. Recall that penultimate stress at the phrase level is mainly due to an RLR edge-marking rule, and to the fact that feet are right-headed (cf. 30). I propose that RLR needs to be restated as follows:

(64) *Phrase level RLR*

$$\emptyset \rightarrow ) / * \_ * ] \text{ line 0}$$

$$\quad \quad \quad |$$

$$\quad \quad \quad \text{CV}$$

Given this formulation, RLR at the phrase level does not apply to phrases that end in a vowel cluster. Since feet are right-headed on line 0, the result is final stress. This is exemplified for *etxeá* below:

<sup>24</sup>Note that in this case, the vowel *e* preceding the deleted *r* is epenthesized to avoid the *sr* consonant cluster. This is the normal epenthetic vowel in Basque (see Hualde 1991c for discussion.)

(65) /etxe+ra/ → etxeá

'house+ALL.SG'

*Word level stress* (21&60)

*Phrase level stress* (22&64)

* line 1	→	* line 1
* (* line 0		* (** line 0
etxea		etxea

Note that, at the word level, (60) renders the last vowel unstressable. However, since new line 0 rules apply at the phrase level, this vowel becomes stressable again, and in fact, is the stressed vowel in the phrase.

Now consider what happens in cases in which the second vowel of a final VV cluster is deleted. As we showed above, the order of rules must be phrase level stress before vowel deletion. The output of the stress rules for a word like *etxi* is as follows:

(66) /etxe+a/ → etxia  $\xrightarrow{\text{Stress}}$  <sup>\*</sup> (\* (\*\* etxia

Next, vowel deletion applies, deleting the stressed vowel. The question now is what happens to the portion of the metrical grid corresponding to this vowel. As first discussed in Halle and Vergnaud 1987, the formalism of the metrical grid predicts that stress shifts to the next available vowel *within the foot*. This basic prediction of the formalism in fact constitutes one of the strongest arguments in favor of the metrical grid over other ones which employ only the grid (e.g. Prince 1983). In the case of Ondarroa Basque, it also makes the correct prediction: as can be seen in (66), there is only one foot on line 0, which contains the two last vowels; after deletion of the rightmost one, i.e. the head of the foot, stress shifts to the vowel which is to the left:

(67) \* line 1  
\* (\* line 0  
etxi

To sum up this section, we have seen that Hualde's (1996) conclusion that the stress data in Ondarroa Basque constitute an argument against derivational phonology is not warranted. Further examination of the data reveals that one of the basic

premises of this argument, that word level stress in final VV clusters is penultimate, is incorrect. Once these data are taken into account, the problematic ordering posited by Hualde is not the only possible one. Furthermore, we have also seen that the new data examined in this section justify certain small changes to the stress rules introduced in the previous sections.

## Chapter 3

### The Nuclear Stress Rule

#### 3.1 Introduction

In this chapter, I propose a new version of the Nuclear Stress Rule (NSR). The main objective of this chapter is to provide a framework for phrase level stress which is able to derive the facts about sentence stress in Ondarroa Basque, to be discussed in the following chapter. §3.2 summarizes the version of the NSR for English proposed in Halle and Vergnaud 1987 (H&V). This work provides the basic framework for the computation of stress at the phrase and compound levels, and introduces several concepts that will be crucial in the new version of the NSR proposed later on in this chapter. In §3.3, I present Cinque's (1993) version of the NSR. As we will see, this version presents certain advantages over H&V's. In particular, Cinque shows that syntactic structure is important in determining the position of primary stress in phrases and compounds. Cinque shows that the following generalizations hold across several languages and constructions:

- (1) a. In a head-complement structure, the complement is prosodically more prominent than the head.
- b. In a specifier- $\bar{X}$  structure,  $\bar{X}$  is prosodically more prominent than the specifier.

Cinque claims that a maximally simple version of the NSR can account for these generalizations (and similar ones in compounds), once we make certain assumptions about the structure of phrases and compounds. In §3.4, I argue for a different version

of the NSR which, unlike Cinque's, makes direct reference to syntactic structure. As will become clear later, this version of the NSR is heavily inspired in Liberman and Prince's (1977) analysis of stress in compounds, although the formalism used is substantially different from the one labeled tree notation used in that work. This new version of the NSR covers the same range of data as Cinque's, and does not need any of the extra assumptions about syntactic structures made by Cinque.

### 3.2 Halle and Vergnaud 1987

H&V propose the following formulation of the NSR for English:

- (2) *H&V: the Nuclear Stress Rule*
- a. Parameter settings on line  $N$  ( $N \geq 3$ ) are  $[-\text{BND}, +\text{HT}, \text{right}]$ .
  - b. Interpret boundaries of syntactic constituents composed of two or more stressed words as metrical boundaries.
  - c. Locate the heads of line  $N$  constituents on line  $N + 1$ .

These are cyclic rules which apply to syntactic constituents larger than the word. Before we see how this version of the NSR deals with the data, there are several clarifying points that need to be made. First, the parameter settings in (2a) apply to line 3 and higher ones in the grid. This is due to the fact that, in their analysis of English stress, word level stress is dependent on line 3 of the grid, i.e. the vowel with primary stress in a word is the one that has a grid element on line 3. Second, their theory of the metrical grid is different from the one used in this thesis. This is seen clearly in (2a). However, it can easily be translated to Idsardi's (1992) formalism:<sup>1</sup>

---

<sup>1</sup>The reader is referred to H&V for details of this version of the metrical grid. The most important difference between this formalism and Idsardi's is that the latter does not assume that a constituent is necessarily defined by both a left and a right boundary. One of them is enough. Another important difference reflected in (2a) is that Halle and Vergnaud (1987) allow for constituents whose head is not the leftmost or rightmost element in the constituent. In the case of the NSR, feet created by the NSR are always headed by the leftmost or rightmost grid element, a consequence of the parameter setting +HT, 'head terminal', in (2a).

(3) *H&V: the Nuclear Stress Rule*

- a. Interpret boundaries of syntactic constituents composed of two or more stressed words as metrical boundaries.
- b. Constituents are right-headed on line  $N$  ( $N \geq 3$ ).

This version of the NSR applies straightforwardly to simple cases such as the following:<sup>2</sup>

- (4) a. <sup>1</sup> Jesus <sup>2</sup> wept.

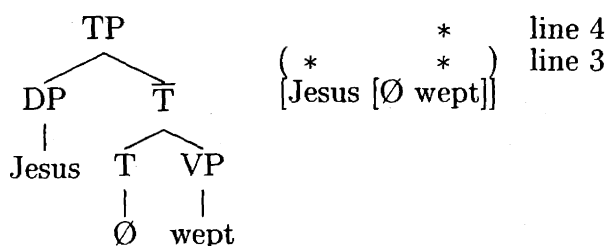

- b. the people of Judea

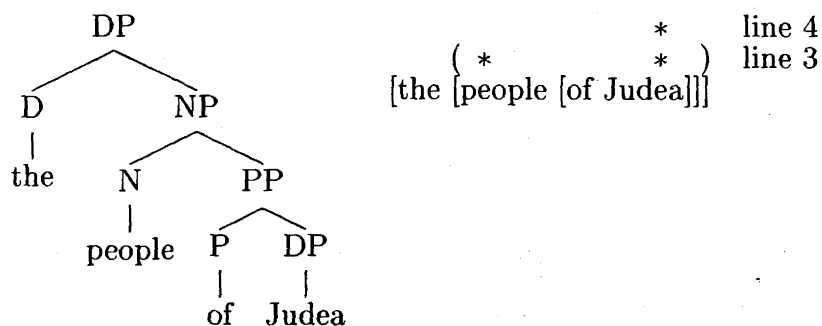

In both cases, only constituents containing two stressed words are considered. For instance,  $\bar{T}$  in (4a) is ignored, since it contains only one stressed word (*wept*); the other subconstituent, T, is phonologically empty and thus is not stressed. Similarly, the PP and the higher DP in (4b) are ignored, since the words *of* and *the* are not stressed. In both cases, there are only two stressed words in the whole phrase, and thus the NSR only applies in one cycle, assigning higher prominence to the rightmost stressed word.

<sup>2</sup>In this examples, and all the ones below, levels of stress are indicated by numbers on top of the stressed vowels, where higher numbers denote higher levels of stress.

H&V's version of the NSR makes correct predictions in these simple cases. They, however, note that something must be added for more complex cases where these small phrases are part of a larger constituent, as in the following:

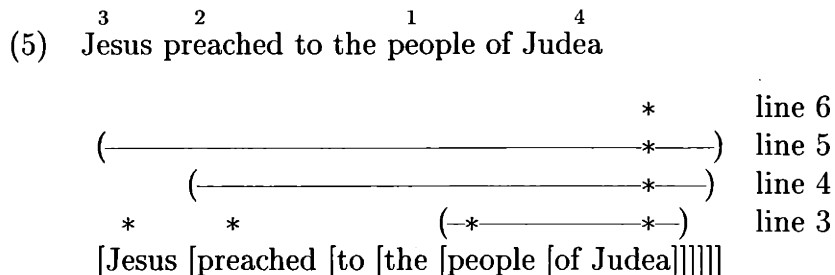

In (5), the NSR applies on three cycles. For ease of exposition, horizontal lines have been added to reflect what constituent the NSR applies to in each cycle: in the first cycle, it applies to [*people of Judea*], in the second, to [*preached to the people of Judea*], and so on.

The problem with (5) is that it does not reflect the fact that *Jesus* is more prominent than *preached*, and that the latter is more prominent than *people*. That is, this version of the NSR only derives correctly primary stress in a given phrase, but not other levels of stress. In order to solve this problem, H&V propose the following convention on the application of the NSR:

(6) *Stress Equalization Convention (SEC)*

When two or more constituents are conjoined into a single higher level constituent, the grid columns of the metrical heads of the constituents are equalized by adding grid elements to the lesser column(s).

The basic idea behind the SEC is that sister subconstituents count as equally prominent when the NSR applies to the constituent containing them. Thus, the NSR never applies vacuously: the SEC ensures that there are at least two grid elements inside every phrase the NSR applies to.<sup>3</sup> The addition of the SEC results in the correct grid for the example above:

<sup>3</sup>The only exception is sentences with only one stressed word, for obvious reasons.

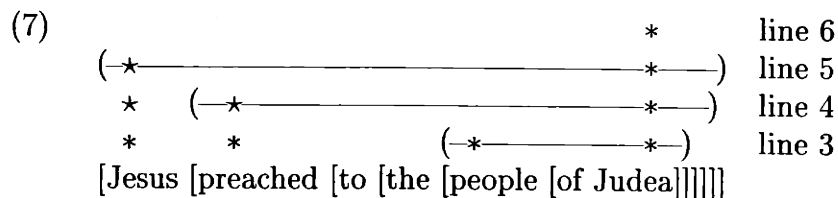

For ease of exposition, in (7), a star ( $\star$ ) is used for grid elements introduced by the SEC, rather than the usual asterisk. In the first cycle, the SEC does not apply, since both stressed words have equal columns. On the second cycle, the SEC applies, equalizing the columns of *preached* and *to the people of Judea* by adding grid elements to the column corresponding to *preached*. Something similar occurs on the last cycle, where the SEC adds more grid elements to *Jesus*. In all the three cycles, the NSR assigns more prominence to the rightmost word, so that in the end, the rightmost word in the sentence has primary stress. Furthermore, the SEC ensures in each cycle that the correct lesser stresses are derived. Thus, the NSR, together with the SEC, derives a representation for the sentence which is in accord with speakers' intuitions about the relative prominence of its constituent words.

The addition of the SEC has another advantage which is not discussed explicitly by H&V. It has to do with complex left branches. If the SEC did not exist, H&V's NSR would predict that complex left branches would be more prominent than they really are. Consider the following example, and its corresponding grid if the SEC did not exist:

(8) *Complex left branches*

1                      2                      3  
The savior of humanity wept.

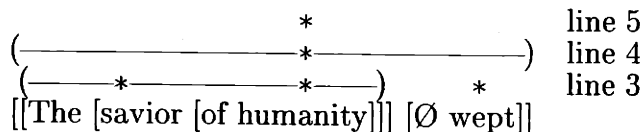
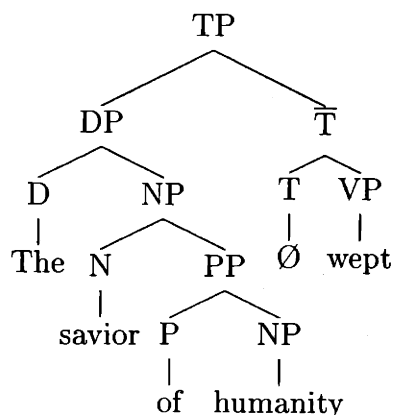

Since the NSR applies cyclically, it predicts that complex constituents are more prominent than simpler ones, simply because the NSR applies to the former more times than to the latter. This is clearly the wrong result, as exemplified in (8). Although it is true that *humanity* is more prominent than *savior*, it is not the case that the most prominent stress is on *humanity*.

However, if we add the SEC, the correct prediction is made:

- (9) *Complex left branches and the SEC*
- |   |       |   |       |   |       |    |        |
|---|-------|---|-------|---|-------|----|--------|
| ( | ————— | * | ————— | * | ————— | *) | line 5 |
| ( | ————— | * | ————— | * | ————— | *) | line 4 |
| ( | ————— | * | ————— | * | ————— | *) | line 3 |
- [[The [savior [of humanity]]] [Ø wept]]

In this case, the SEC ensures that the stress on *wept* is prominent enough so that it can ‘compete’ in the last cycle, even though the constituent containing it,  $\bar{T}$ , is simpler than its sister, the subject DP.

### 3.3 Cinque 1993

Cinque (1993) proposes a new formulation of the NSR which, he argues, has several advantages over previous ones. Two properties distinguish it from previous ones: (i) it is ‘minimal’, in the sense that it only uses the minimal machinery necessary to derive stress in phrases, and (ii) it is not language-particular. In this section, I discuss Cinque’s proposal, and argue that it has certain shortcomings. In particular, as discussed by Cinque himself, property (i) relies on certain crucial assumptions about syntactic structures which are not independently motivated. These problems with Cinque’s theory will motivate a new version of the NSR in §3.4 which covers the same range of data as Cinque’s, but which does not need these assumptions.

#### 3.3.1 The NSR in Phrases

Cinque’s basic idea is that, once we assume a rich enough syntactic structure, such as standard  $\bar{X}$ -Theory, stress rules which determine headedness at the phrase level

are not necessary. Consider, for instance, one of the DPs discussed in the previous section, and its syntactic structure according to  $\bar{X}$ -Theory:<sup>4</sup>

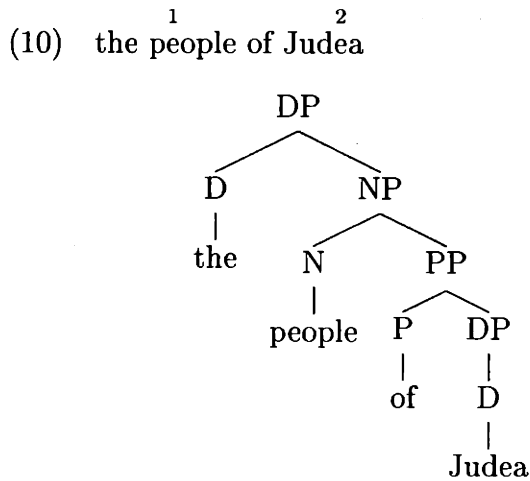

There is a clear asymmetry between the two stressed words in this phrase: *Judea* is more deeply embedded than *people*: the former is dominated by more phrasal nodes than the latter. This means that the cycle applies more times to constituents containing the former than to constituents containing the latter. Cinque's basic idea is that this can be used to derive the correct stress contour for this phrase, and, in fact, for all phrases. If we apply the stress rules to all constituents, including those that contain only one stressed word, the prediction is that the word which is more deeply embedded than the rest will be the most prominent one. In simple cases such as (10), this prediction is borne out, as will be shown below.

Cinque's formulation of the NSR is as follows:

- (11) a. Interpret boundaries of syntactic constituents as metrical boundaries.<sup>5</sup>  
 b. Locate the heads of line  $N$  constituents on line  $N + 1$ .  
 c. Each rule applies to a maximal string containing no internal boundaries.  
 d. An asterisk on line  $N$  must correspond to an asterisk on line  $N + 1$ .

<sup>4</sup>I assume that proper names in English are generated directly in D. This assumption is not crucial. For instance, we could assume that they surface in D via N-to-D movement, following Longobardi 1994, or that they are generated and remain in N, with an empty D.

<sup>5</sup>Note that these are phrase level boundaries, not word level ones. This is simply a consequence that the algorithm applies to phrase level categories.

The only crucial rule which makes this version of the NSR different from previous ones is (11a): *all* syntactic boundaries are interpreted as metrical boundaries. Recall that, in H&V's NSR, only constituents that have more than one stressed word are considered. It is this rule that results in the prediction that highest prominence is assigned to the most deeply embedded constituent. Consider the simple example in (10) under Cinque's NSR: since all syntactic boundaries are interpreted as metrical boundaries, the first cycle applies to the DP containing only *Judea*, and then to the PP of *Judea*:

$$\begin{array}{rcl}
 (12) & & \begin{array}{r} \text{*} \quad \text{line 5} \\ \text{ ( ( ( \text{---*} )) ) } \quad \text{line 4} \\ \text{ ( ( * ( \text{---*} )) ) } \quad \text{line 3} \\ \text{ [the [people [of [Judea]]]]} \end{array} \\
 & \rightarrow & \begin{array}{r} \text{*} \quad \text{line 5} \\ \text{ ( ( ( \text{---*} )) ) } \quad \text{line 4} \\ \text{ ( ( * ( \text{---*} )) ) } \quad \text{line 3} \\ \text{ [the [people [of [Judea]]]]} \end{array}
 \end{array}$$

In the next cycle, the NSR applies to the constituent containing both stressed words (*people* and *Judea*). However, since the NSR has already applied twice to constituents containing *Judea*, its column in the grid is higher than the one for *people*. In particular, on line 5, there is only a grid element corresponding to *Judea*, not to *people*. Hence, *Judea* ends up having more prominence than *people*, as desired:

$$\begin{array}{rcl}
 (13) & & \begin{array}{r} \text{*} \quad \text{line 7} \\ \text{ ( \text{---*} ) } \quad \text{line 6} \\ \text{ ( ( \text{---*} )) } \quad \text{line 5} \\ \text{ ( ( ( * )) ) } \quad \text{line 4} \\ \text{ ( ( * ( ( * )) ) ) } \quad \text{line 3} \\ \text{ [the [people [of [Judea]]]]} \end{array} \\
 & \rightarrow & \begin{array}{r} \text{*} \quad \text{line 7} \\ \text{ ( \text{---*} ) } \quad \text{line 6} \\ \text{ ( ( * )) } \quad \text{line 5} \\ \text{ ( ( ( * )) ) } \quad \text{line 4} \\ \text{ ( ( * ( ( * )) ) ) } \quad \text{line 3} \\ \text{ [the [people [of [Judea]]]]} \end{array}
 \end{array}$$

Thus, there are two important differences between Cinque's and H&V's versions of the NSR. In the latter, only constituents containing more than one stressed word are considered, and certain rules determine that the rightmost one is more prominent. In the former, all constituents are considered, and, Cinque claims, this is enough to determine prominence, at least in simple cases.

Let us consider one more simple example: the intransitive sentence *Jesus wept*, from (4) above:

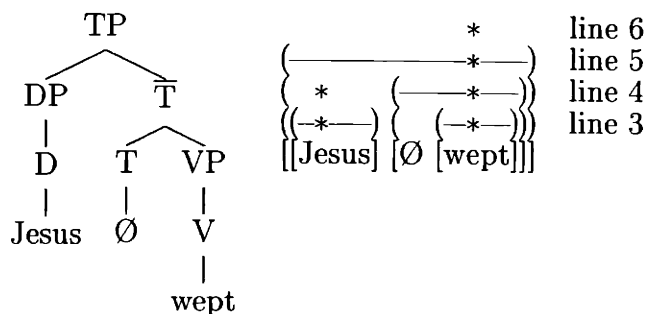
(14) <sup>1</sup> Jesus <sup>2</sup> wept.

In this example, *wept* receives more prominence for the same reason that *Judea* does in the previous example: *wept* is more deeply embedded than *Jesus*. The former is contained in VP,  $\bar{T}$ , and TP, and the latter is contained in DP and TP. This means that the stress rules apply to *wept* more times than it does to *Jesus*, which results in higher prominence on the former.

To sum up so far, Cinque's version of the NSR accounts for a number of simple cases, and it does so without any rule stipulating which member of a metrical constituent is the head. In this sense, it has a clear advantage over H&V's NSR, where such rules are needed. Cinque goes on to claim that this version of the NSR is universal, or that at least it can account for the phrasal stress facts of languages that in other theories require language particular versions of the NSR. A language that Cinque considers at length is German, which is sufficiently different from English in its syntax to make significant predictions.

Consider the following transitive sentence, and the structure which Cinque assumes for it:<sup>6,7</sup>

- (15) ...dass Hans zwei **Flöße** gebaut hat.  
 ...that Hans two rafts built has  
 ...that Hans has built two rafts.

<sup>6</sup>Note that this sentence must be embedded, since it starts with the complementizer *daß* and is not V2. Matrix V2 sentences are discussed below.

<sup>7</sup>In this example, and in the ones below, the word containing the most prominent stress is given in bold-face.

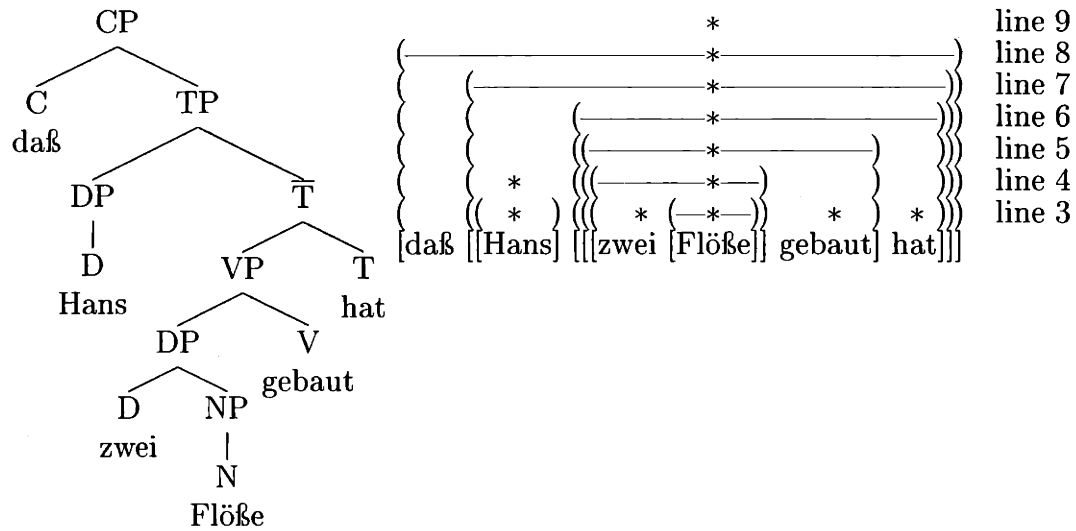

As shown in this example, Cinque's NSR makes the right prediction: sentence prominence is assigned to the noun *Flöße*, since it is contained in the the most deeply embedded constituent in the sentence. In order to understand the advantages that this theory has over H&V's, it is useful to compare this German sentence with its English equivalent:

(16) ...that Hans has built two **rafts**.

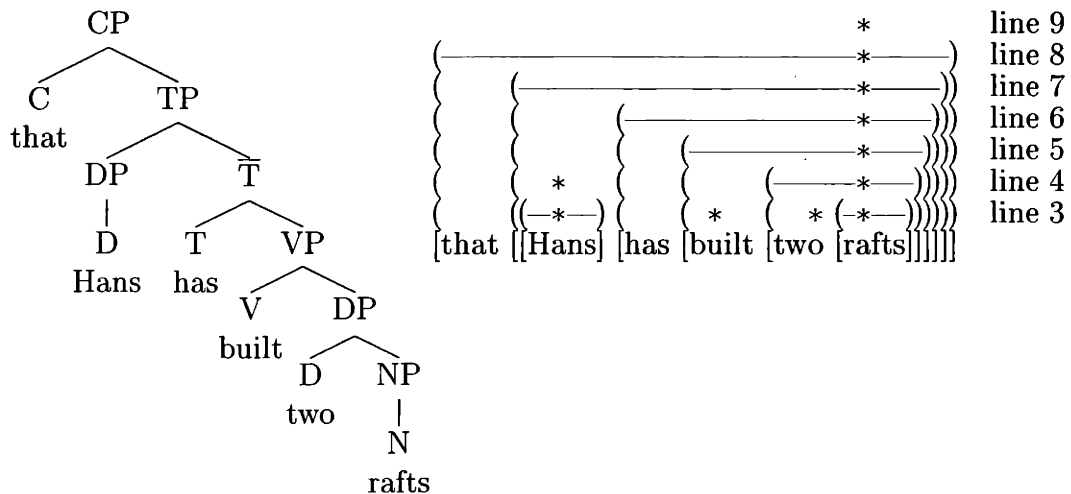

As in the German example, sentence prominence is predicted to be on the noun *rafts*. If we adopted H&V's theory, we would be forced to propose two different versions of the NSR, one for English (i.e. 3), and a different one for German. If we applied H&V's NSR for English to German, we would obviously make the wrong prediction. In Cinque's theory, these facts in these two languages are analyzed in a uniform

way: sentence prominence is on the most deeply embedded constituent. Apparent surface differences in the distribution of stress are reduced to independently motivated differences in the syntax of these two languages.

It is important to note that this property of Cinque's analysis relies strongly on certain basic features of  $\bar{X}$ -Theory. A crucial step in the derivation of sentence stress in the examples above is the first cycle within the VP, which applies to the NP containing *rafts/Flöße*. The structure that  $\bar{X}$ -theory assigns to the DP *two rafts/zwei Flöße* is as follows:

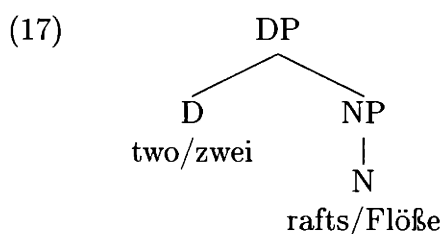

In this structure, the noun *rafts/Flöße* is embedded in an NP which contains nothing else but that noun. This is due to one of the basic hypotheses of  $\bar{X}$ -Theory, namely, that complements (and specifiers) are phrases. Thus, in a structure of the form [X Y], where X is the head, Y cannot be the complement of X unless Y is phrasal. That means that a DP like the one above has minimally the structure shown above. Consequently, the noun is more deeply embedded than the determiner within the DP, which, eventually, results in the noun being assigned sentence prominence.

More generally, Cinque's prediction is that any word in the complement of a head X counts as more deeply embedded than X, and thus receives higher prominence than X. This seems like the right prediction, since it is borne out in all the examples we have seen so far. For instance, a basic difference between the German and English counterparts of the sentence we discussed above is that the VP is right-headed in the former, but left-headed in the latter. In both cases, the NSR assigns higher prominence to the complement of V, as predicted by Cinque's theory.

As noted by Cinque, this prediction is in fact borne out by a large number of cases that have been discussed in the literature (see Cinque 1993, §8, for relevant references). This raises the question of what predictions are made under other theories of phrase

structure. This is a topic that is dealt with in §3.3.3.

Further support for Cinque's theory comes from matrix sentences in German. As is well-known, matrix sentences in this language are subject to a V2 condition: the tensed verb must be placed after the first XP in the sentence. Following the standard analysis of this fact in the literature (references?), Cinque assumes that it is the consequence of the tensed verb moving to from T to C, and some XP moving to the specifier position of C. In the following, it is the subject *Hans* that appears in first position:

- (18) Hans baute zwei **Flöße**.  
 Hans built two rafts  
*Hans built two rafts.*

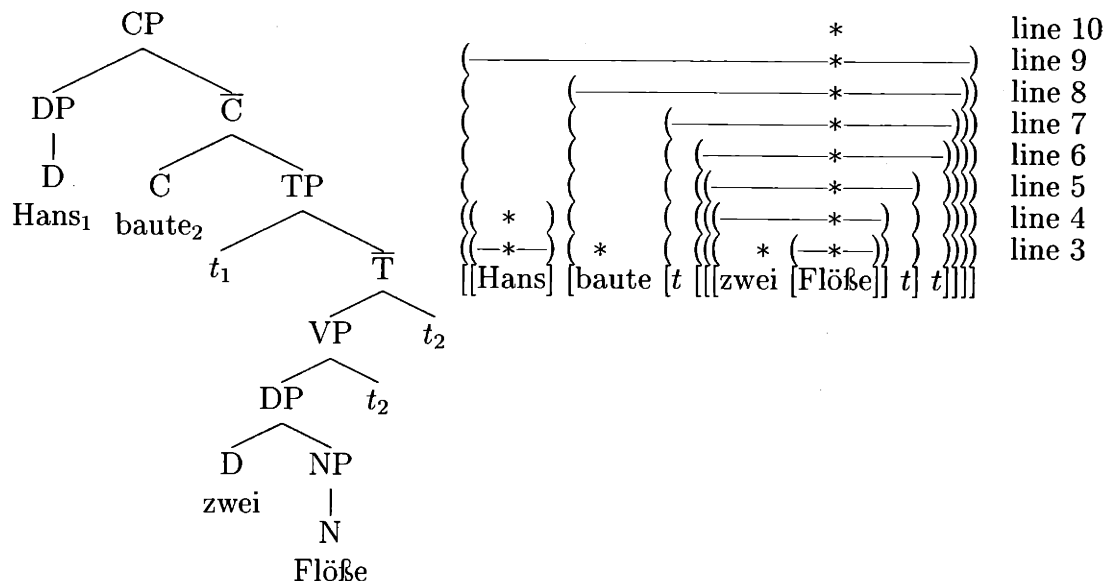

In this example, as in the one above, sentence prominence is correctly predicted to be on the noun *Flöße*. If we did not take into account the basic structural difference between V2 and non-V2 clauses, the difference between their stress patterns would be puzzling. In V2 clauses, stress is on the rightmost word, and in non-V2 clauses, it is not. Under H&V's theory, we might account for these data by assuming that, as in English, stress is rightmost, but that some additional rules exclude verbs from the computation of sentence prominence.<sup>8</sup> That this is the correct generalization is

<sup>8</sup>What exactly this rule would look like is not important for the point made in the text. A possibility would be to adopt H&V's rule for stress in compounds for German sentences, by stipulating

confirmed by V2 sentences in which some verb remains within TP, as is the case in sentences with compound tenses:

- (19) Hans hat zwei Flöße gebaut.  
 Hans has two rafts built  
*Hans has read two books.*

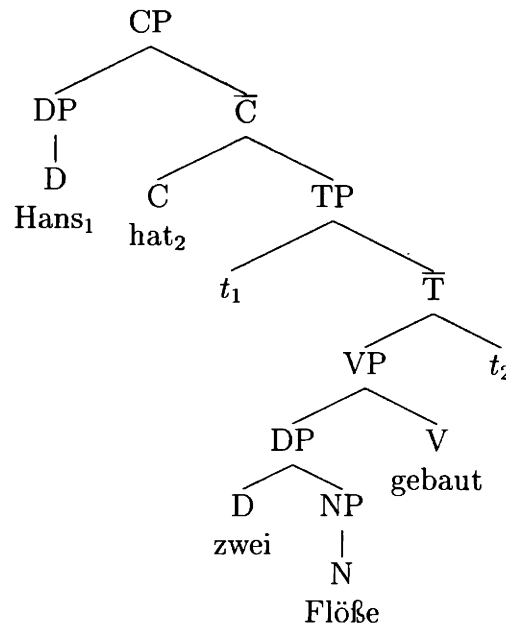

In this example, as in the ones above, sentence prominence falls on the last word, excluding verbs. However, in H&V, this fact must be stipulated. The advantage of Cinque's theory is that this fact is explained: in all cases, sentence prominence is assigned to the most deeply embedded constituent.

### 3.3.2 Stress in Compounds

Cinque claims that his theory of phrase stress can also be applied successfully to English compounds, once we assume a sufficiently rich structure for them. In most two-membered compounds, stress is on the first member (see Chomsky and Halle 1968):

- (20) a.       <sup>2</sup> kitchen <sup>1</sup> towel

---

that the right boundary of a constituent composed of two or more words is displaced to the left of the head if the head is the last word in the constituent.

- b. <sup>2</sup> towel <sup>1</sup> rack  
 c. <sup>2</sup> teachers <sup>1</sup> union

In Chomsky and Halle 1968, the compound stress rule basically states that primary stress in a compound is assigned to the leftmost word in each cycle. This rule can handle simple compounds like the ones above, but it cannot account for certain structure-dependent effects that are observable in more complex compounds:

- (21) a. <sup>3</sup> kitchen <sup>1</sup> towel <sup>2</sup> rack

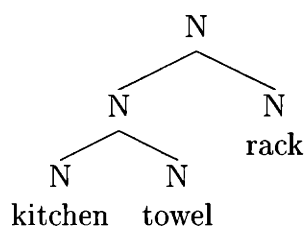

- b. <sup>2</sup> kitchen <sup>3</sup> towel <sup>1</sup> rack

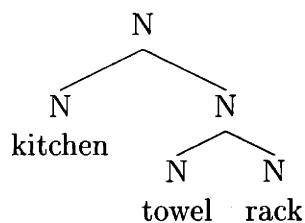

Although (21a) can be accounted for by assigning higher prominence to the leftmost constituent in each cycle, (21b) cannot be accounted for in this way. What these examples show is that the syntactic structure of compounds is relevant in determining their stress. In previous analyses of compound stress (e.g. Chomsky and Halle 1968, Liberman and Prince 1977, H&V), right and left-branching compounds are treated as basically subject to different stress rules. For instance, in Liberman and Prince 1977, the rightmost element in a compound is more prominent if it branches; otherwise, the leftmost element is more prominent.

However, Cinque claims, treating these two kinds of compounds in terms of different rules misses an obvious generalization. As can be seen in the examples in (21), the most prominent word is always contained in the more complex branch. This fact can be stated straightforwardly in terms of depth of embedding. For instance, in

(21a), both *kitchen* and *towel* are more deeply embedded than *rack*. Similarly, in (21b), both *towel* and *rack* are more deeply embedded than *kitchen*. However, depth of embedding apparently does not help in determining which word in the complex branch is more prominent, since both words are as deeply embedded as the other, given the structure in (21). The same problem arises in two-membered compounds, such as the ones in (20)

Rather than amending the NSR, Cinque proposes that the structure of compounds is more complex than standardly assumed. In particular, he challenges the assumption that compounds have a symmetric structure, where both the head and the modifier are of the same  $\bar{X}$  level ( $X^0$ ). He claims that while the head is a  $X^0$  level category, the modifier is phrasal (i.e. XP). The basic idea is that headedness in  $\bar{X}$ -theory is expressed in asymmetries of this type. Thus, the structure of a two-membered compound such as *towel rack* is as follows:

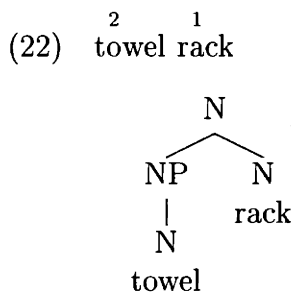

In this structure, *towel* is more deeply embedded than *rack*, and thus applying Cinque's NSR to it gives the correct result:

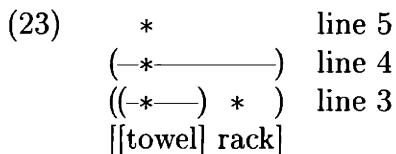

Since compounds are always right-headed, this predicts that stress is always leftmost in two-membered compounds, which is true for most cases.<sup>9</sup>

The same correct result is also derived for three-membered compounds:

<sup>9</sup>There are well-known exceptions to this generalization. See, among others, Halle and Vergnaud 1987, Selkirk 1984, Cinque 1993. I leave this as a question for future research.



b. kitchen towel rack deposit

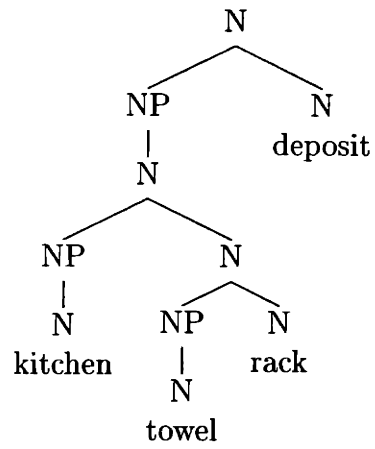

c. kitchen towel rack deposit warden

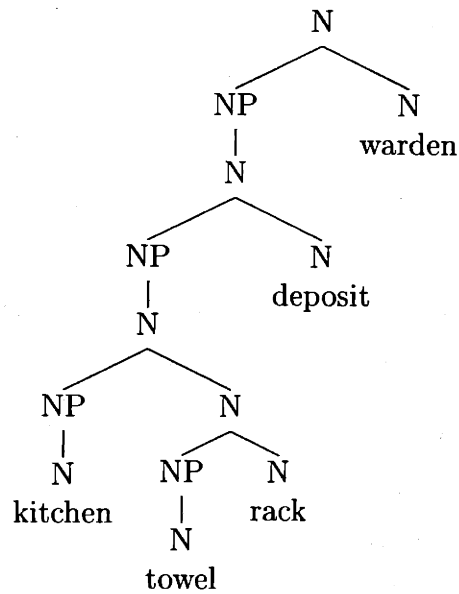

d. labor union **finance** committee president

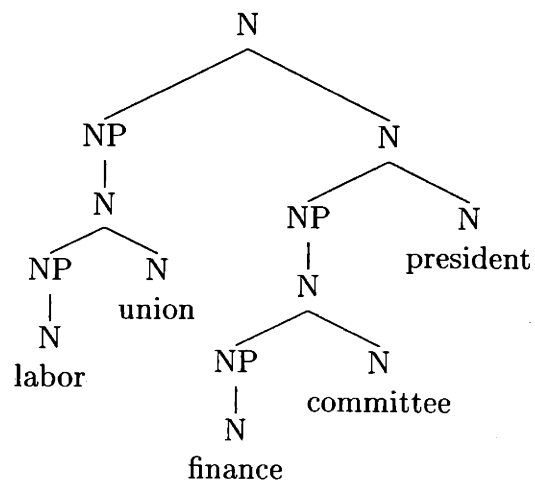

As we will see in the next section, Cinque's final version of his theory about the structure of compounds is somewhat different from what we have seen above. However, the basic idea remains unchanged: certain  $\bar{X}$ -theory concepts are applicable at the word level, and this permits the NSR to apply correctly to compounds.

### 3.3.3 The NSR and Syntactic Structure

In the previous sections, we have seen that Cinque's version of the NSR has certain advantages over H&V's. In particular, it does not need rules to specify what element in a foot is the head, and it can account in a uniform way for stress patterns in different construction types and in different languages. Cinque's basic insight is that the NSR is to a large extent determined by the syntactic structure of phrases, so that apparent differences in the stress patterns of different constructions/languages are reduced to independently motivated differences in their syntax.

In this section, I point out certain problems with Cinque's analysis, some of which were noticed by Cinque himself. I argue that these problems show that, while structure sensitive, the NSR cannot be as simple as in Cinque's version. Cinque's formulation of the NSR crucially relies on certain assumptions about syntactic structures which are not independently motivated. The issues raised in this section will motivate a new version of the NSR in §3.4 which makes direct reference to syntactic structures, and which does not need these extra stipulations.

The first objection to Cinque's NSR was already noted in 3.3.1. Consider the following DP, with the metrical grid assigned to it in Cinque's theory:

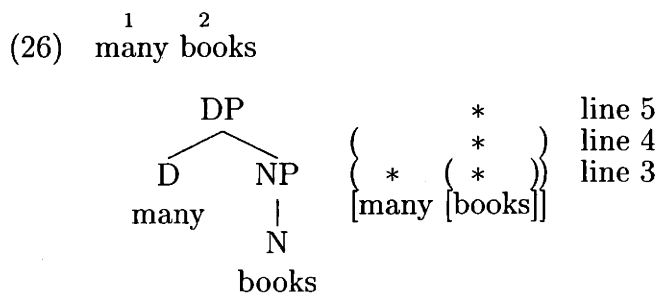

As was noted in §3.3.1, in order to derive the correct stress pattern in this phrase, the analysis relies on the distinction between word level and phrase level categories

that is stipulated in  $\bar{X}$ -Theory. In particular, since, in this theory, complements (and specifiers) are stipulated to be phrasal, *books* in this example is contained in an NP which is the complement of the D head. Thus, the noun is more deeply embedded than the determiner, and receives higher prominence. More generally, a phrase XP containing a head X and a complement YP has minimally the following structure:

(27) *Complements are phrases in  $\bar{X}$ -Theory:*

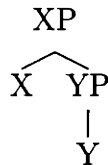

As long as this stipulation is maintained, any word in the complement of a head X counts as more deeply embedded than X, and thus receives higher prominence than X. This seems like the right prediction, since it is borne out in all the examples we have seen so far. This raises the question of what predictions are made under other theories of phrase structure. In particular, we need to ask whether we can obtain the same result within Chomsky's (1995) Bare Phrase Structure (BPS).

In BPS, syntactic structure is built by a single operation, *Merge*.<sup>10</sup> Merge is a recursive operation which takes two syntactic objects and forms a new syntactic object. In the newly formed object, one of its members is designated as its *label*. For instance, the phrase *many books* is formed by merging the two lexical items it is composed of. The resulting object has *many* as its label, and can be represented as follows:

(28) many books

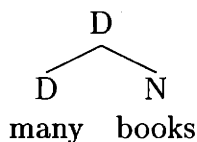

A basic constraint on phrase structure posited in BPS is the *Inclusiveness Condition*: properties of a syntactic objects are only those that are inherited from the lexical

<sup>10</sup>Another operation which builds structure is Move, which is a combination of Merge and Agree. See Chomsky 2000, 2001 for details.

items it is composed of. This amounts to saying that syntactic objects can only be created by Merge.

Thus, BPS imposes very restrictive conditions on possible syntactic structures. In particular, a structure like (27) is not possible: the structure  $[_{YP} Y]$  cannot be formed by merge, since it contains only one subconstituent. Furthermore, given the inclusiveness condition, YP cannot have any property that Y does not have. In  $\bar{X}$ -theory, it is stipulated that Y and YP are different: Y is a word level category, and YP is a phrase level category. In Cinque's analysis this is precisely what introduces an asymmetry between X and Y and what is ultimately responsible for complements being more prominent than heads.

It seems then that Cinque's theory of nuclear stress and BPS are not compatible, since the asymmetries that are needed to derive the correct stress patterns are not possible in BPS. One way of maintaining both theories would be to examine all the problematic cases and show that they involve more structure than meets the eye. Consider the DP *many books* again. Several authors have proposed that DPs contain functional projections between D and N (e.g. Ritter 1993, Cinque 1994). If we posit an empty functional head in this DP, it is possible to derive the correct stress pattern under Cinque's theory:

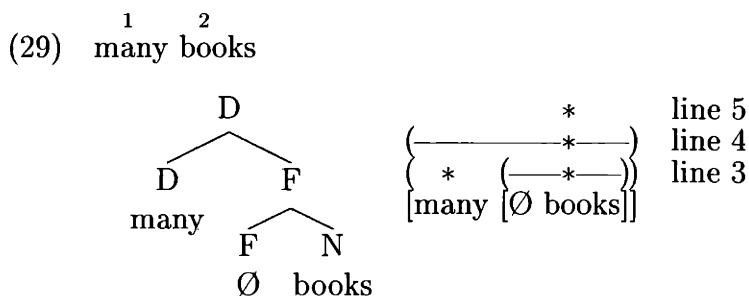

In this structure, the empty functional projection introduces the necessary asymmetry that makes *books* more deeply embedded than *many*.

As long as we can posit enough empty structure in all the problematic cases, Cinque's theory can be made compatible with BPS. However, rather than examining all possible cases, I would like to point out a more serious problem for Cinque's theory. As I argue in §3.4, the solution to this new problem also solves the problem with complements.



However, the problem is more serious than in H&V's theory. Cinque's basic hypothesis is that depth of embedding correlates with prosodic prominence. Phrases with complex specifiers, such as the one above, are clear counterexamples to this hypothesis. Furthermore, this problem cannot be solved by adopting the SEC. The SEC is designed precisely to remove the effects of depth of embedding. In particular, if we added the SEC, the metrical grid in the cycle which applies to *savior of humanity* would be as follows:

- (33) ( \*                    \*        ) line 5  
       ( \*    (-----\*-----) ) line 4  
       ( \*    ( (-----\*-----) ) ) line 3  
       [savior [of [humanity]]]

At this point, line 5 has a foot that contains two grid elements. Since Cinque's NSR crucially relies on there being only one grid element in each foot, it cannot deal with representations of this type. Thus, Cinque's theory is not compatible with the SEC.

In general, specifiers are not more prominent than their sisters. This generalization can be exemplified further with genitive phrases, which, I assume, are specifiers of D (see Abney 1987):<sup>11</sup>

- (34) the man from Philadelphia's hat

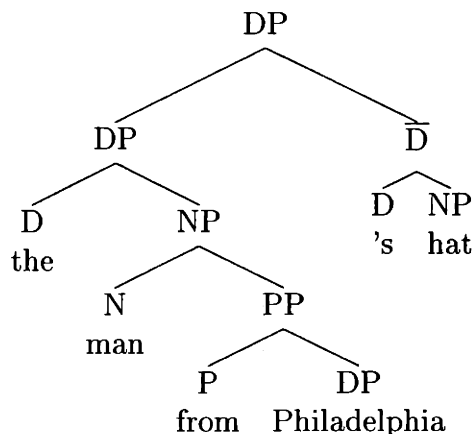

As in the previous example, Cinque's (wrong) prediction is that stress is on the most deeply embedded constituent, i.e. *Philadelphia*.

<sup>11</sup>I assume that the genitive morpheme 's is generated as the head of the DP containing the genitive phrase. Another possibility would be to assume that D is empty, and that the genitive morpheme heads the phrase in the specifier of DP. See Abney 1987 for discussion.

Cinque proposes the following amendment to his theory as a solution to this problem with specifiers. His basic idea consists in excluding specifiers from the computation of nuclear stress in a principled fashion. First, he notes that “it is well known that the complement, not the specifier, introduces recursion, so that depending on the relative position of the complement and the head a language will be right-recursive (say, Italian) or left-recursive (say, Japanese).” He cites several works which provide evidence for asymmetries between recursive and non-recursive sides from several languages (Zwarts 1973, Emonds 1976, 1985, Williams 1982, Longobardi 1991). He then proposes that “the relevant notion of depth of embedding is now limited to the continuous path uniting from the bottom all and only the nodes found on the recursive side and on the X-bar projection line of a phrase up to the node that is expanded on the nonrecursive side.” For instance, the following tree has several such paths of embedding:

(35) *Depth of embedding and recursion*

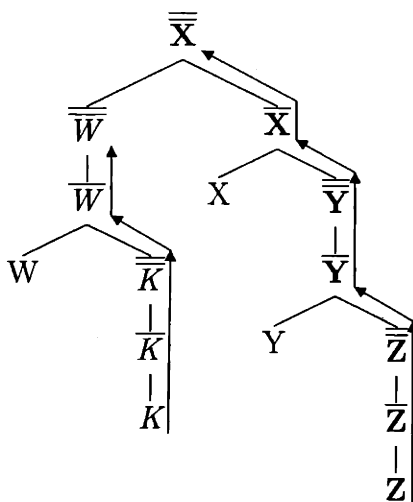

Two paths of embedding are marked in this example: the one connecting the root ( $\overline{\overline{X}}$ ) to the terminal Z, and the one connecting the specifier  $\overline{\overline{W}}$  to the terminal K.<sup>12</sup> Cinque defines the one connecting the root to a terminal node (i.e. Z) as the *main path*, and the one that does not include the root node as a *minor path*. His amendment to

<sup>12</sup>There are, of course, more paths of embedding, i.e. one for each terminal node W, X, and Y. These are not relevant for Cinque's proposal.

the theory of stress is that “when a minor path of embedding joins the main path (i.e. when the minor cycle joins the main cycle), only the end result of the former is visible in the form of a single asterisk.” This means that, whatever metrical grid is computed in the specifier ( $\overline{W}$ ) cycle, only one asterisk from this grid is visible in the grid computed in higher cycles (i.e. in  $\overline{X}$ ).

Unfortunately, Cinque does not state more explicitly what it means “to be visible in the form of a single asterisk.” However, the basic idea seems to be that specifiers count as words with respect to stress, i.e. when joining the main path of embedding, the metrical grid of a specifier is visible only in terms of a word level (line 3) asterisk on top of the word (vowel) containing primary stress in the specifier. Consider one of the problematic examples again:

(36) The savior of humanity wept.

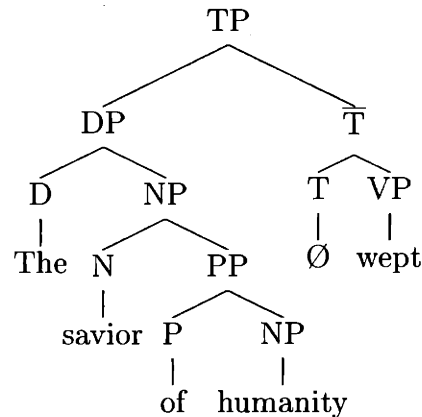

First, the metrical grids for DP and  $\overline{T}$  are computed on separate cycles:

(37)

(	*	line 7	
(	*—	line 6	
(	( —*— )	line 5	*
(	( ( —*— ) )	line 4	( —*— )
(	( * ( ( —*— ) ) )	line 3	( ( —*— ) )
	[The [savior [of [humanity]]]]		[∅ [wept]]

In the root cycle, the grid for the DP is simplified, since it is a specifier:

(38)

(	*	line 6
(	*—	line 5
(	( * )	line 4
(	* ( ( * ) )	line 3
	[[The [savior [of [humanity]]]] [∅ [wept]]]	

Cinque argues that this solves a similar problem that arises in compounds. The following is a relevant example:

(39) hotel kitchen towel rack

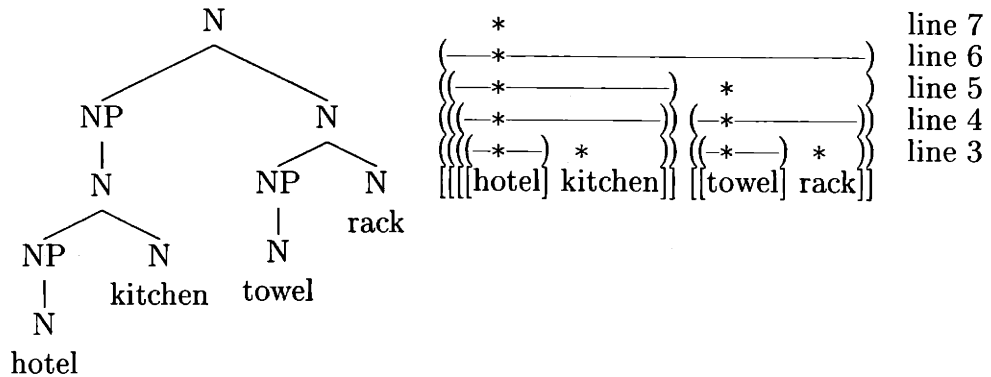

The problem with this example is basically the same that we saw above with respect to specifiers. Cinque’s theory, without the amendment discussed above, predicts that the most deeply embedded constituent has primary stress. Although this is true in many cases, it is not in others.

Cinque argues that this problem has exactly the same solution that he proposes for the problem with specifiers. These two problems can be schematized as follows:

(40) *Complex left branches in phrases and compounds*

a. *Phrases*

b. *Compounds*

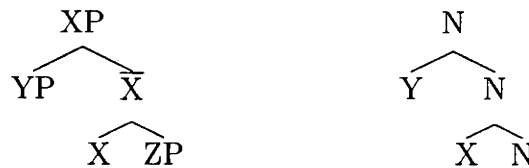

In both cases, the generalization is that the non-head daughter of the root node (YP and Y, respectively) does not attract stress, regardless of its complexity. Drawing on this similarity, Cinque extends certain concepts of  $\bar{X}$ -theory to the compound level. In particular, he proposes that Y and X in (40b) are the specifier and the complement of the head, respectively, and that this is expressed in terms of sub-zero bar-levels:

(41) *Cinque 1993: the structure of compounds:*

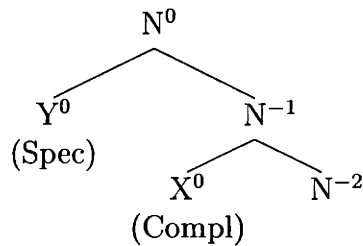

The basic idea is that, at the word level,  $X^0$  counts as a ‘maximal projection’, and thus there are lower X-bar levels ( $-1$  and  $-2$ ).

Given this structure, the constituent *hotel kitchen* in the problematic compound (39) is a specifier. Given Cinque’s proposal about specifiers, its metrical grid is simplified, so that it does not attract nuclear stress:

(42) hotel kitchen towel rack

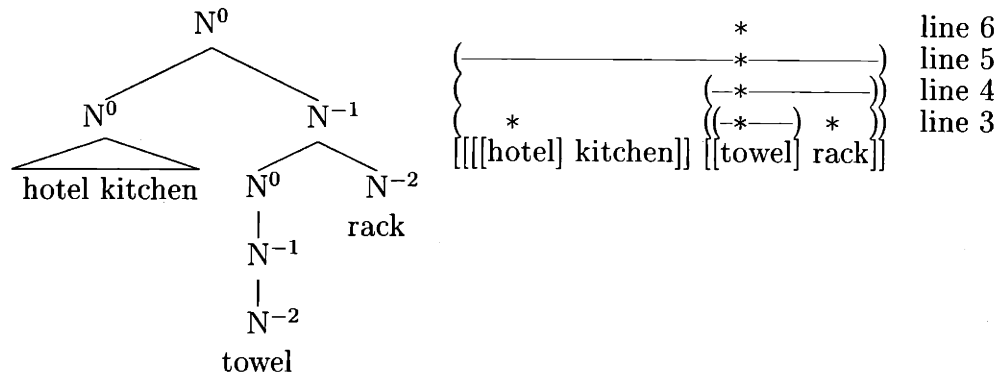

To conclude, several stipulations about phrase structure, the structure of compounds, and how the cycle works permit Cinque to maintain a maximally simple version of the NSR. In the following section, I explore a different alternative which, although a bit more complex than Cinque’s, does not need these stipulations and covers the same range of data.

### 3.4 A Structure-Based Definition of the NSR

In previous sections, we have seen that syntactic structure determines the placement of stress at the phrase level in the form of the following generalizations:

- (43) a. In a head-complement structure, the complement is prosodically more prominent than the head.

- b. In a specifier- $\bar{X}$  structure,  $\bar{X}$  is prosodically more prominent than the specifier.

Although Cinque's theory derives these generalizations, it does so with the addition of certain assumptions about syntactic structures and the application of the NSR. In particular, he derives (43b) by stipulating that only part of the metrical grid of a specifier is considered when computing stress in higher cycles (see §3.3.3). He also argues that this can also be extended to handle similar data in compounds, once we make certain assumptions about their structure.

In this section, I propose an alternative version of the NSR which does not need these extra assumptions. The basic idea is to incorporate generalization (43b) into the formulation of the NSR. As will be shown below, this implies making explicit reference to syntactic structure in our stress rules. In this sense, this version of the NSR is heavily influenced by Liberman and Prince 1977, although the formalism to be used is quite different from theirs. As we will see, this addition to the NSR has several advantages. First, it not only accounts for generalization (43b), it also accounts for (43a). Second, it allows us to account for the stress pattern of compounds. Finally, it makes the extra assumptions needed by Cinque's NSR unnecessary. In §3.4.1, I introduce this new version of the NSR, and show how it makes correct predictions in phrases. In §3.4.2, I argue that this version of the NSR can also account for stress in compounds.

### 3.4.1 Stress in Phrases

As we saw in §3.3.3, Cinque's version of the NSR has problems with specifiers because, in this theory, complex branches, including complex specifiers, attract primary stress. As stated in (43b), this prediction is wrong: quite generally, specifiers do not attract primary stress. This problem is illustrated in the following sentence:

(44) *Cinque 1993: complex left branches*

1                    2  
The savior wept.

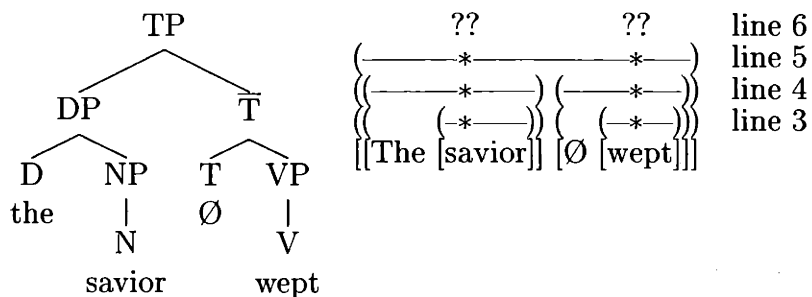

Since *savior* is as deeply embedded as *wept*, the prediction is that neither is more prominent than the other. Cinque's solution is to stipulate that the metrical grid of the subject *the savior* is visible only in terms of a single asterisk.

I would like to explore a different alternative, namely, to incorporate this property of specifiers into the formulation of the NSR. The basic idea is that, in two-membered feet, like the one on line 5 in (44), the grid element corresponding to the non-specifier is the head of the foot. In order to make this more precise, we need to make the notion 'specifier' clearer. In both  $\bar{X}$ -theory and BPS, concepts like 'specifier' and 'complement' are not primitives. In BPS, they can be defined as follows:

(45) *Specifiers and complements in BPS*

- a. A *complement* is the sister of a non-branching head.
- b. A *specifier* is the sister of a branching head.

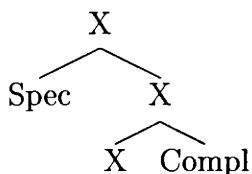

Given these definitions, we can state the NSR as follows:

(46) *The Nuclear Stress Rule*

On line  $N(N \geq 3)$ :

- a. Edge-marking: RRR:  $\emptyset \rightarrow ) / *\_ ]$

b. In the following configuration:

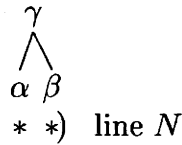

The grid element corresponding to the head of  $\gamma$  is the head of the foot iff the head of  $\gamma$  is branching.

Consider example (44) again, with its structure in BPS and with the grid assigned to it by this new version of the NSR:

(47) <sup>1</sup> The <sup>2</sup> savior wept.

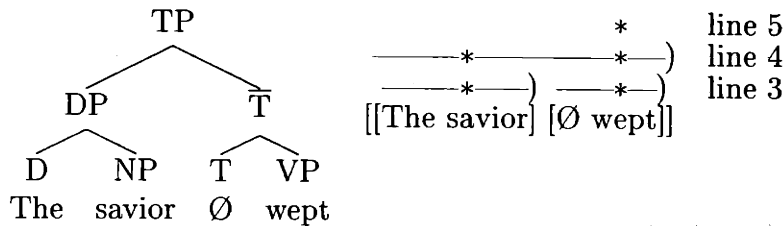

The crucial step is the projection from line 4 to 5. On line 4, there is a foot corresponding to TP, containing two grid elements: one corresponding to the subject DP, and another one corresponding to  $\bar{T}$ . Since  $\bar{T}$  is the head and it branches, its corresponding grid element is designated as the head of the foot by (46b), and projects to line 5.

The current theory can handle complex specifiers in cases such as (47), where both the specifier and its sister have the same complexity. However, cases in which the specifier is more complex than its sister are more complicated:

(48) <sup>1</sup> The <sup>2</sup> savior <sup>3</sup> of humanity wept.

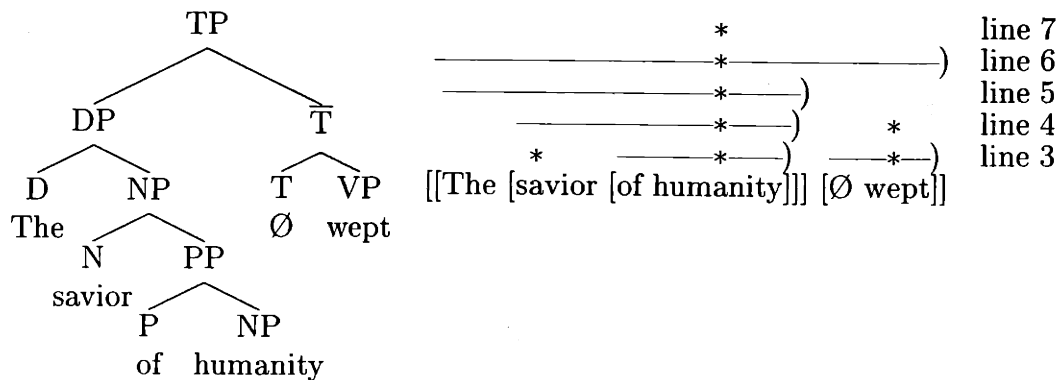

The problem raised by this example is by now a familiar one: since the NSR is a cyclic rule, it applies more times to complex branches than to simpler ones, so that the former are predicted to attract stress, which is the wrong result. Even though the current version of the NSR states that a specifier (i.e. the sister of a branching head) is less prominent than its sister, this can only apply in two-membered feet. In this example, the subject is more complex than  $\bar{T}$ , which means that the foot on line 6 contains only one grid element, the one corresponding to the subject. This grid element is thus designated as the head of the foot, giving the wrong result.

Thus, we need something else to ensure that  $\bar{T}$  in (48) is as prominent as the subject when the NSR applies to the constituent that contains both (TP), so that the NSR can assign more prominence to  $\bar{T}$ . Recall from §3.2 that H&V's solution to this same problem is their SEC, repeated below as (49):

(49) *Stress Equalization Convention (SEC)*

When two or more constituents are conjoined into a single higher level constituent, the grid columns of the metrical heads of the constituents are equalized by adding grid elements to the lesser column(s).

We can incorporate the SEC to our analysis in order to obtain the correct result in cases like (48). The stress of the subject and  $\bar{T}$  is computed on separate cycles:

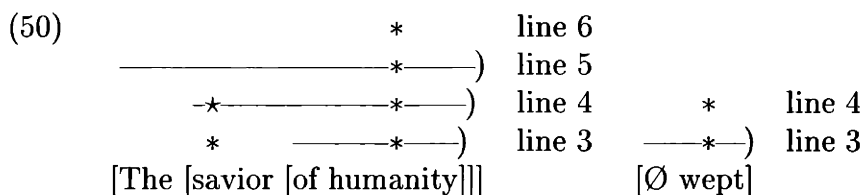

On the next cycle, the SEC ensures that the highest columns in the subject and in  $\bar{T}$  are of the same height, and then the NSR gives more prominence to  $\bar{T}$  (i.e. the branching head), giving the correct result:

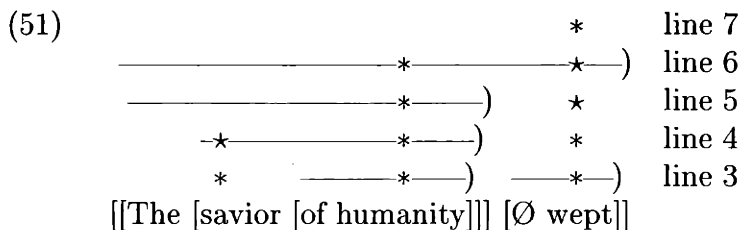

Another example illustrating the problem with complex specifiers is (34), repeated below as (52).

(52) The man from Philadelphia's hat.

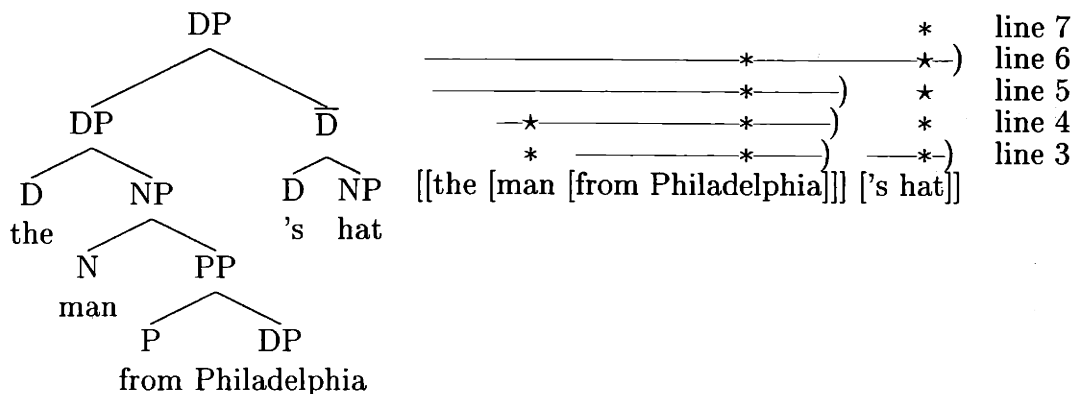

In this case, the SEC ensures that the columns corresponding to the specifier of the topmost DP and  $\bar{D}$  are of the same height, and the NSR gives more prominence to  $\bar{D}$ , as desired.

To sum up so far, the current version of the NSR derives the correct results for complex specifiers by adding a headedness rule (46b) which, in essence, makes  $\bar{X}$  more prominent than its sister. It is important to note that the rule does not mention specifiers explicitly. It is stated in terms of the more basic notions of 'head' and 'branching'. This has several advantages. First, it makes predictions for the stress pattern of constructions in which there are no specifiers, but in which the more basic notions 'head' and 'branching' are relevant. As I argue in §3.4.2, these predictions are correct in the case of compounds. Second, as I show immediately below, it also derives the other generalization about phrase level stress, namely, that a complement is more prominent than its sister (cf. 43a).

Recall that Cinque's account of this generalization relies on the basic hypothesis made in  $\bar{X}$ -theory that complements are phrasal. This provides Cinque with the asymmetry that is needed in his theory, as exemplified in the following DP:

(53) many books

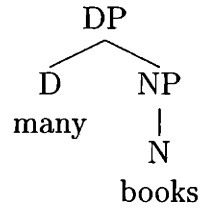

Since the complement *books* must be phrasal, this word is more deeply embedded than the head *D*, which in Cinque's theory results in more prominence on the former.

In the current version of the NSR, this assumption about complements is no longer necessary. Again, the relevant part of the NSR is the headedness rule, repeated below:

(54) In the following configuration:

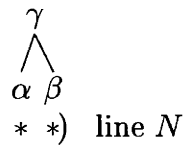

The grid element corresponding to the head of  $\gamma$  is the head of the foot iff the head of  $\gamma$  is branching.

This rule basically states that a head is more prominent than its sister iff it is branching. Since, in every foot, there must be an element which is more prominent (i.e. the metrical head of the foot), in all other cases (i.e. when the head is not branching), the sister of the head is more prominent.

This 'elsewhere' case is what allows us to account for the generalization about complements, since a complement, by definition, is the sister of a non-branching head:

(55) *Complements*

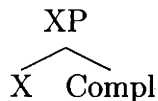

Thus, the assumption that complements are phrasal is not necessary to account for this generalization. Consider again the DP *many books*:

(56) <sup>1</sup> many <sup>2</sup> books

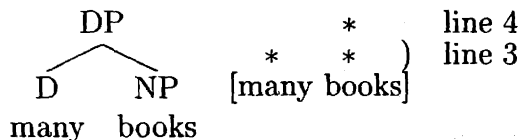

The foot corresponding to the DP contains two grid elements: one corresponding to the head *many*, and another one corresponding to the complement *books*. Since the head is not branching, the elsewhere clause of (54) applies giving the complement more prominence, as desired.

Since rule (54) assigns more prominence to a complement than to the corresponding head, irrespective of their order, it also makes correct predictions in right-headed phrases. This can be illustrated with one of the German examples discussed in §3.3:

- (57) ...dass Hans zwei Flöße gebaut hat.  
 ...that Hans two rafts built has  
 ...that Hans has built two rafts.

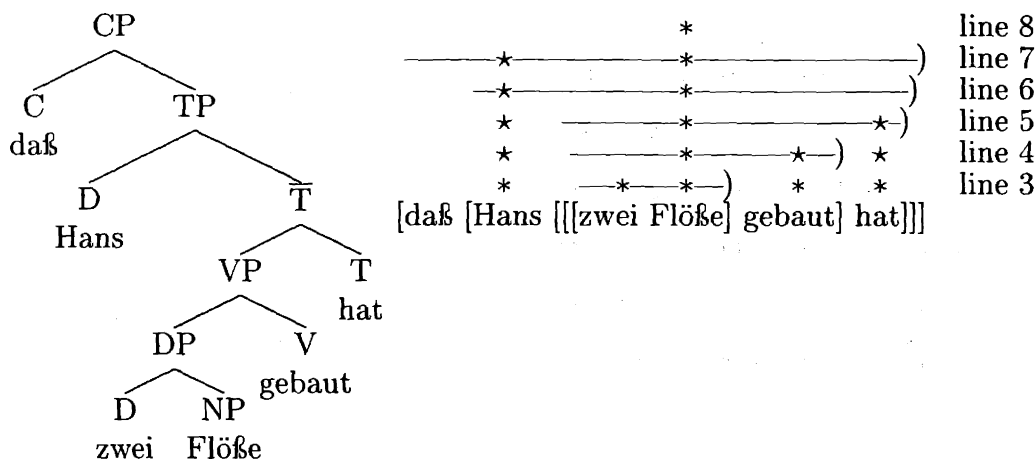

The crucial step is the projection from line 4 to 5. At this point, the NSR applies to the VP *zwei Flöße gebaut*:

- (58)           \*           line 5  
               \*       \*   ) line 4  
               [[zwei Flöße] gebaut]

Line 4 contains one foot corresponding to the VP, which has two grid elements: one corresponding to the head *gebaut*, and another one corresponding to the complement *zwei Flöße*. Since the head is not branching, the NSR assigns more prominence to the complement.

The present theory has another advantage over Cinque's, having to do with different levels of stress. As noted by Cinque, his theory does not account for lesser stresses in a sentence. This can be illustrated with the following sentence:

- (59) *Cinque 1993: levels of stress*  
<sup>3</sup> <sup>2</sup> <sup>1</sup> <sup>4</sup>  
 Jesus preached to the people of Judea.

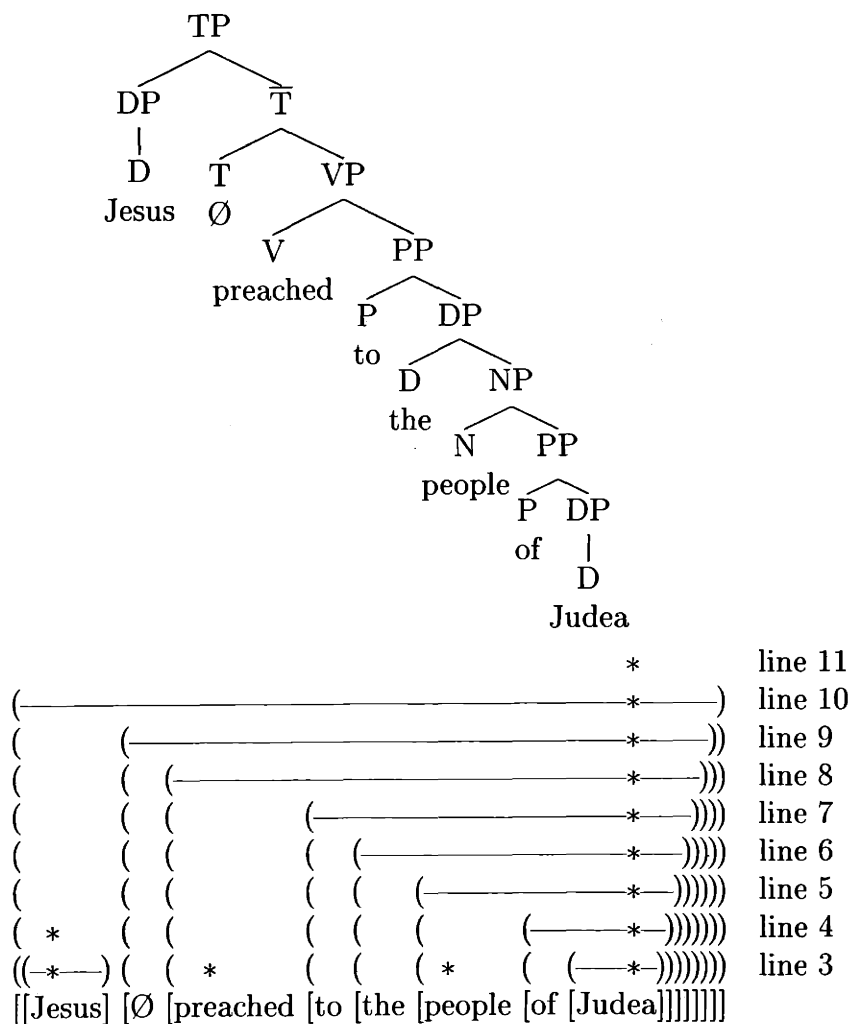

Although Cinque's analysis derives the fact that *Judea* has primary stress, it has nothing to say about the level of stress on *preached* and *people*. It cannot capture the fact that the former is more prominent than the latter. In footnote 9, he notes that

If this is a clear and perceptible intuition, then the procedure (10) will need to be amended. "Supplementary principles of prosodic realization" (Prince 1983:24) are likely to superimpose themselves on the effects of the



### 3.4.2 Stress in Compounds

The current version of the NSR accounts for the generalizations in (43) by adding a rule which determines which member of a foot is the head:

(61) *The Nuclear Stress Rule*

- a. Edge-marking: RRR:  $\emptyset \rightarrow ) / * \_ ]$
- b. In the following configuration:

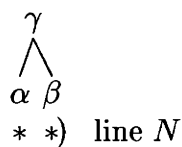

The grid element corresponding to the head of  $\gamma$  is the head of the foot iff the head of  $\gamma$  is branching.

Since this rule does not mention complements and specifiers explicitly, it also makes predictions for constructions in which there are no complements or specifiers.

In fact, as we saw in §§3.3.2-3.3.3, stress in compounds obeys certain generalizations that are very similar to those found in stress in phrases. Cinque, noting these similarities, proposes a new theory of the syntax of compounds that makes them compatible with his version of the NSR. These generalizations about stress in compounds can be summarized in the following (taken from Liberman and Prince 1977):

(62) In a configuration  $[_C A B C]$ , if C is a lexical category, B is strong iff it branches.

Although (62) is stated in Liberman and Prince's (1977) labeled tree notation, it can easily be restated in terms of the metrical grid:

(63) In the following configuration:

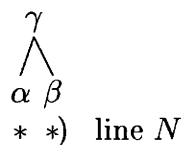

where  $\gamma$  is a lexical category, the grid element corresponding to  $\beta$  is the head of the foot iff  $\beta$  branches.

Since compounds in English are always right-headed, this is in fact a subcase of our version of the NSR (61). Thus, the current theory can account for stress in compounds without any modification.

Consider first two-membered compounds, where primary stress is on the leftmost member:

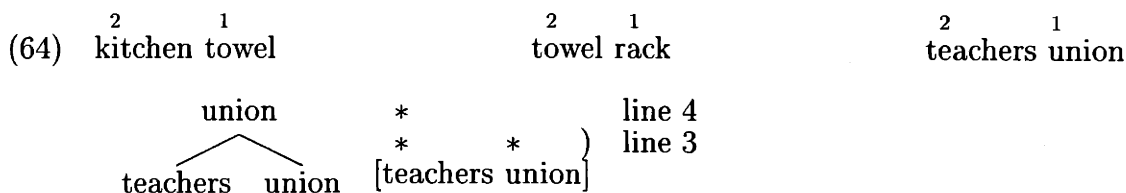

In compounds, the head is always rightmost. In these simple cases, the head is not branching, and thus primary stress is assigned to the non-head (i.e. the leftmost member).

Consider next the contrast between left and right-branching compounds:

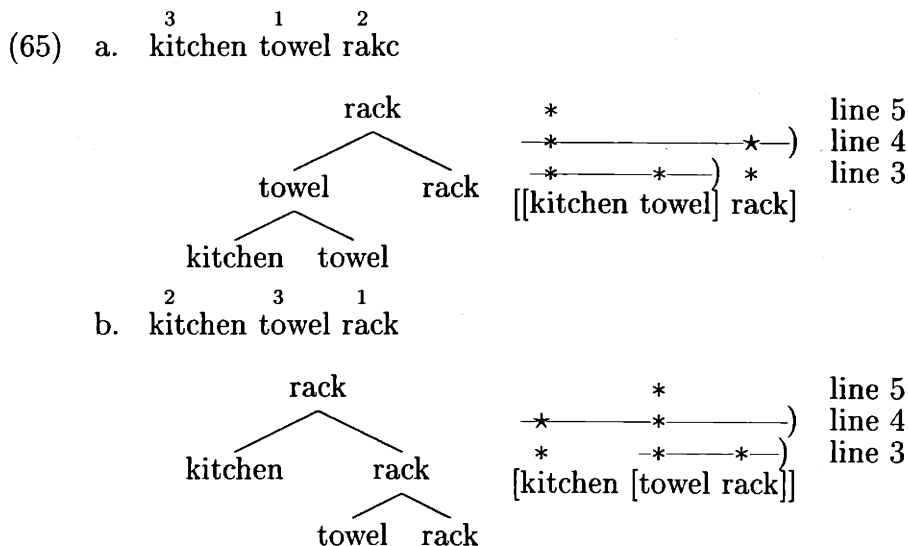

Left-branching compounds like (65a) are similar to two-membered compounds. In the first cycle, higher stress is given to the leftmost member of *kitchen towel*. On the second cycle, the head *rack* is not branching, and more prominence is given to the non-head (i.e. to *kitchen*). In right-branching compounds like (65b), the NSR applies first to *towel rack*, giving more prominence to the leftmost member. On the next

cycle, *towel rack* is the head, and, since it is branching, it is given more prominence than its sister *kitchen*. Note also that the SEC ensures that the correct levels of stress are assigned in both types of compounds.

Recall that Cinque needs to make substantial revisions to the theory of compounds in order to account for their stress patterns, even in simple cases like the ones we just examined. In particular, he proposes that compounds have a structure similar to phrases, with different (subzero) bar-levels, and with complements and specifiers. The following is one of the more problematic examples which motivate his new theory of compounds:

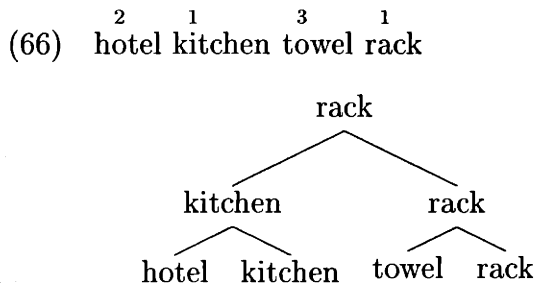

Under the structure given, there is no terminal node which is more deeply embedded than any other terminal node. Thus, Cinque needs to enrich the syntactic structure of compounds in order to obtain the asymmetries that are needed in his version of the NSR. These asymmetries are not needed in the current theory, and the correct stress pattern is predicted under the simple structure in (66):

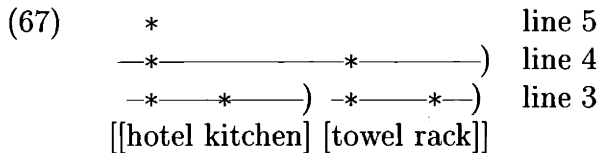

On the last cycle (projecting from line 4 to 5), the head *towel rack* is branching and thus is assigned primary stress.

In the remainder of this section, I illustrate the NSR further with other examples of compounds that were discussed in previous sections.

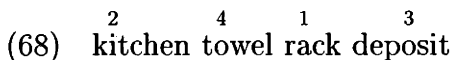

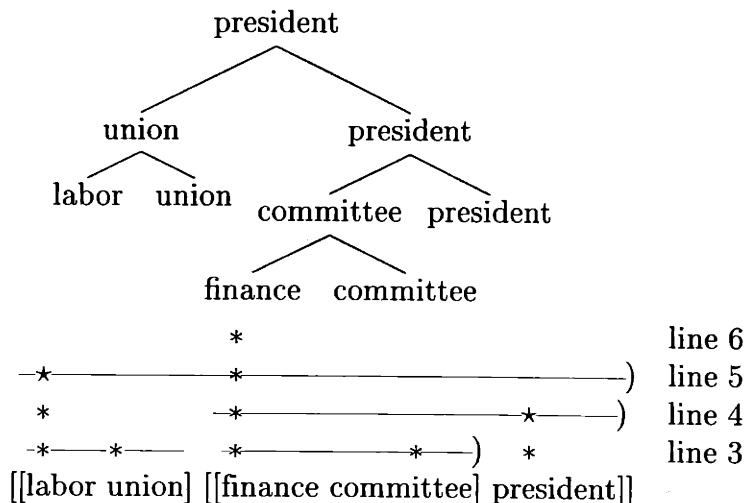
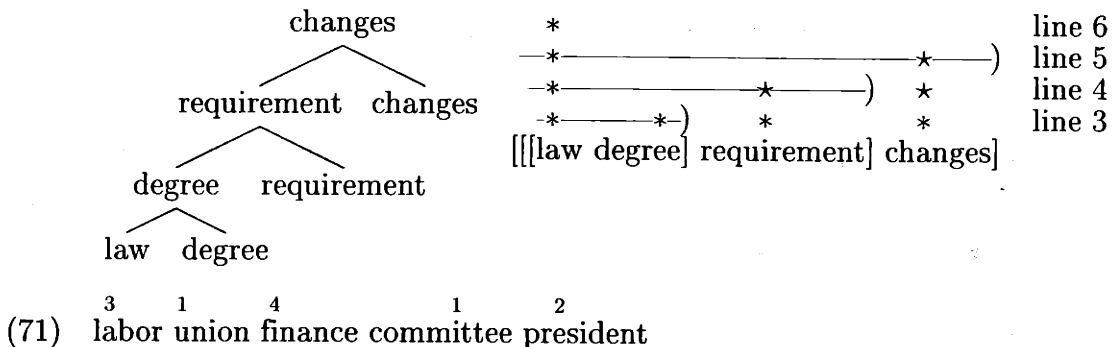
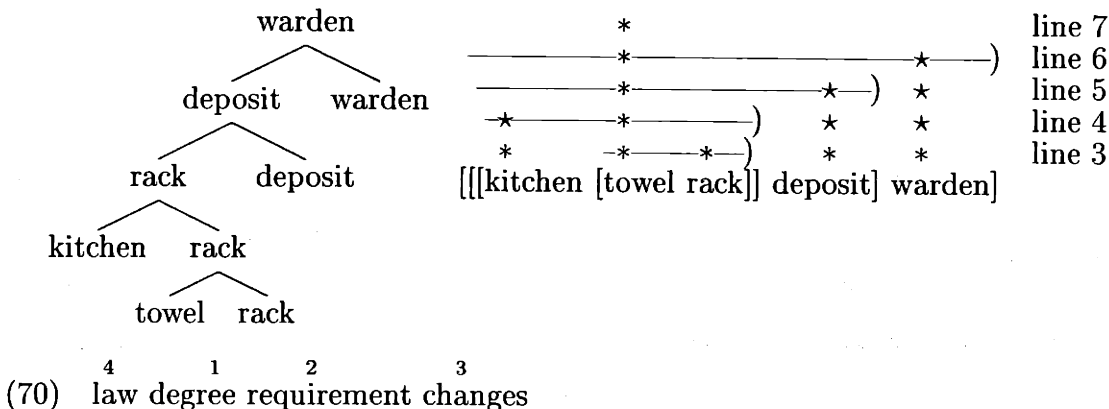
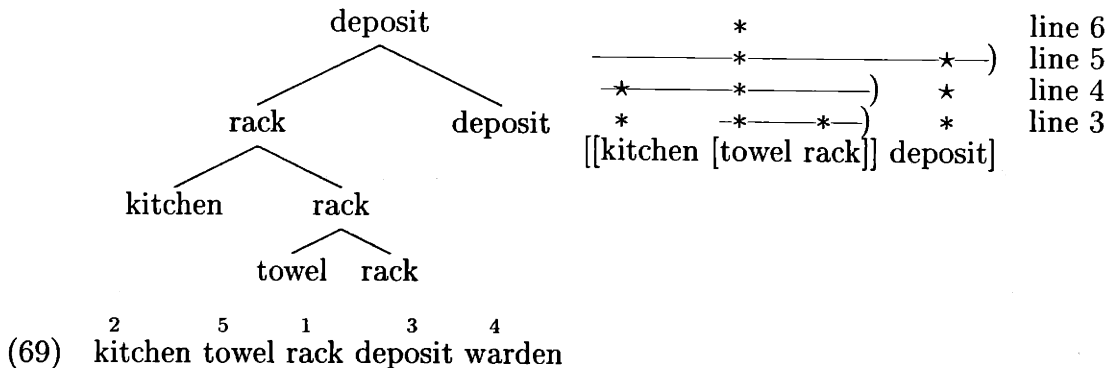

### 3.5 Conclusion

In this chapter, I have proposed a new version of the NSR which accounts for several stress facts in phrases and compounds. Like Cinque's (1993) version, sentence stress in this analysis is highly dependent on syntactic structure. However, I have shown that the facts about phrase and compound stress placement cannot be reduced to Cinque's 'minimal' theory. First, as noted by Cinque, the generalization that primary stress is on the most deeply embedded word is not correct in several cases. In order to account for these cases, Cinque resorts to additional assumptions having to do with the structure of phrases and compounds.

In the analysis proposed in this chapter, it has been argued that these additional assumptions are not necessary. First, following H&V, I have argued that the SEC is necessary in the framework of the metrical grid. This is what allows us to account for lower levels of stress in phrases and compounds. At the same time, it also helps solve the problem with complex specifiers. In particular, the SEC eliminates the effects that depth of embedding has on stress, so that complex specifiers do not (necessarily) attract primary stress. In order to account for the effect that syntactic structure has on the placement of stress, the NSR proposed in this chapter makes crucial reference to two properties of syntactic structure: headedness and branchingness. The basic idea is that the relevant generalizations about syntactic structure and stress can be reduced to the simple statement that a head is more prominent than its sister if and only if it branches.

To conclude, the NSR proposed in this thesis accounts for all the facts discussed in this chapter. In the following chapter, I apply this NSR to Basque sentences, arguing that it makes correct predictions about sentence stress in this language. This provides further support for the version of the NSR proposed here.

## Chapter 4

# The Nuclear Stress Rule in Ondarroa Basque

### 4.1 Introduction

In this chapter, I argue that the NSR that was proposed in §3 makes correct predictions in Ondarroa Basque. §4.2 introduces certain important aspects of clause structure in Basque that will be important in implementing the NSR in this language. In §4.3–4.6, I show that the NSR accounts for the basic facts of sentence stress in Ondarroa Basque, and discuss how movement can affect what constituent in the sentence receives primary stress. Thus, the facts presented in this chapter provide further support for the version of the NSR proposed in §3.

The version of the NSR defended in this thesis is structure-sensitive, and predicts that different syntactic structures result in different stress patterns. However, as was shown in §2, there are certain phrases whose structure does not in any way determine the placement of stress in them. On the other hand, this chapter also argues that, in certain domains, stress placement *is* structure-sensitive, as predicted by the NSR. In §4.7 I propose that, although the NSR is universal, there is parametric variation in the domains in which it applies. Thus, I argue that in English, the NSR applies at all levels above the word, but that in Ondarroa Basque (and other Basque dialects) it does not apply inside DPs and the verbal complex. In §4.8, I show that the fact that the NSR in this language does not apply in DPs has the consequence that many sentences can be described in terms of Cinque's generalization that sentence stress is on the most deeply embedded constituent. In this section, I provide data for which this generalization does not hold, thus lending further support for the version of the

NSR proposed in §3.

## 4.2 Basic Clause Structure

In this section, I present some basic facts about the structure of sentences in Basque, concentrating on the aspects of the structure which will be relevant for the analysis of sentence stress to be developed in later sections. In §4.2.1, I discuss the syntax of verbs and tense, and in §4.2.2, I present the basic facts about word order and the distribution of arguments.

### 4.2.1 The Syntax of Verbs

Following Laka 1990 and Arregi 2000, I assume that sentences in Basque have the following basic structure:

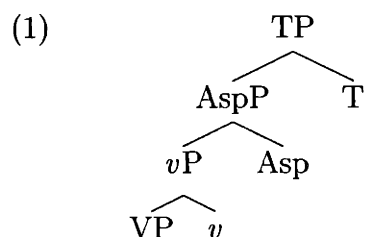

All sentences contain a *v* head whose complement is VP (see Chomsky 1995, 2000, Marantz 1997). The external argument, when present, is generated in the specifier position of this head. Basque sentences also contain an Asp head, which encodes perfective or imperfective aspect. In the syntax, V moves to *v*, and the V+*v* complex moves to Asp:

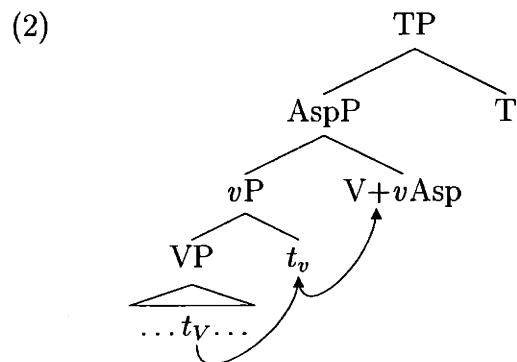

In most cases, the  $V+v+Asp$  complex stays in *Asp*, and an auxiliary *V* is adjoined to *T* in order to satisfy the requirement that *T* must be affixed to verb (see Laka 1990, Arregi 2000 for details). These operations result in a compound verb containing two verbal words: the *participle* (i.e.  $V+v+Asp$ ) and the *auxiliary* ( $Aux+T$ ).<sup>1</sup> The following are some examples of compound tenses:<sup>2</sup>

(3) *Present Tense:*

- a. Jonek liburo asko irakur+ten dau.  
Jon.E book many.A read+IMP Aux.PR  
*Jon reads many books.*
- b. Aitorrek Bilboa ju+n de.  
Aitor.A Bilbao.IN go+PRF Aux.PR  
*Aitor has gone to Bilbao.*

(4) *Past Tense:*

- a. Jonek liburo asko irakur+te ban.  
Jon.E book many.A read+IMP Aux.PST  
*Jon used to read many books.*
- b. Aitorrek Bilboa ju+n san.  
Aitor.A Bilbao.IN go+PRF Aux.PST  
*Jon went to Bilbao.*

There are a small number of verbs which, besides the tenses described above, also have simple tenses. The list of verbs which can appear in simple tenses varies from dialect to dialect. In Ondarroa Basque, these verbs are *ixan* and *eon* ‘be’<sup>3</sup>, *euki*

<sup>1</sup>The tensed verb is also inflected for agreement with the ergative, absolutive and dative arguments (if present) in the clause. The form of the auxiliary depends on the presence versus absence of ergative agreement in the tensed verb. In the former case, the auxiliary is the root of *edun* ‘have’, and in the latter case, the root of *ixan* ‘be’. Although these details have been ignored for ease of exposition, they do not involve significant changes to the analysis proposed. See Arregi 1999, 2001a and references cited there, for details and discussion of Basque verbal morphology.

<sup>2</sup>These are only a subset of all the possible compound tenses in Basque. There are two future tenses, which are built with a future participle and a present or past auxiliary. There are also so called ‘conditional’ and ‘potential’ tenses, which are constructed with certain modal heads that are adjoined to *T*. Finally, there is also an imperative tense, and, in other dialects, there are also two subjunctive tenses (present and past). All these involve functional projections which have not been included in (1) above. Their syntax, however, is basically the same as the tenses described in the text.

<sup>3</sup>The difference between *ixan* and *eon* is the same as that between Spanish *ser* and *estar*. Roughly, *ixan* is used with individual level predicates, and *eon* with stage level predicates.

‘(possessive) have’, *jun* ‘go’, *etorri* ‘come’, *ibilli* ‘walk, go’, *erun* ‘take, carry’, *jakin* ‘know’. Simple tenses are characterized by a single verbal word which is inflected for (present or past) tense<sup>4</sup>, and in which there is no overt aspectual morphology:

- (5) a. Jonek gausa asko raki.  
 Jon.E thing many.A knows  
*Jon knows many things.*
- b. Miren Bilboa ixun.  
 Miren.A Bilbao.ALL go.PST  
*Miren was going to Bilbao.*

These tenses are formed by movement of the V+v+Asp complex to T. Since this satisfies the requirements of T, no auxiliary is necessary:<sup>5</sup>

- (6) *Simple Tenses:*

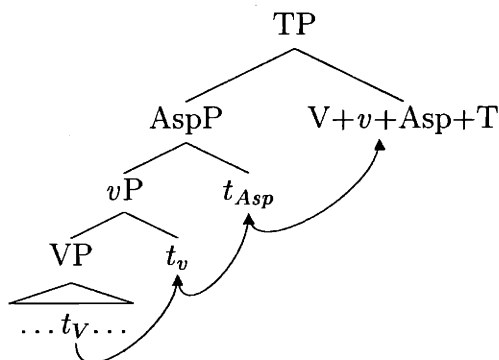

To sum up so far, Basque has two basic types of tenses: simple tenses, in which Asp moves to T, and compound tenses, in which there is no movement to T. I have

<sup>4</sup>In fact, the verbs *etorri*, *ibilli* and *erun* only have simple present forms in Ondarroa Basque. Quite generally, simple tense paradigms are quite poor compared to compound tense paradigms. For instance, transitive auxiliaries in compound tenses can be inflected for any person in the absolutive (with certain well-known restrictions, such as the *me-lui* constraint), but in simple tenses, only third person is possible. For instance, while there is a simple tense form for *I have him* ('dakat'), there is no simple tense form for 'I have you'. Whenever there is no simple form available, the corresponding compound form is used. These facts vary greatly from dialect to dialect.

<sup>5</sup>As I argue in Arregi 2000, Asp in simple tenses is imperfective and non-habitual. Although this is not crucial for our purposes in this thesis, it is important to bear in mind that only a few verbs can appear in simple tenses, i.e. movement from Asp to T is only licensed in very restrictive contexts: (i) it is only possible with certain verbs, and (ii) it is only possible with a particular choice of Asp. For most verbs, imperfective non-habitual aspect results in an imperfective compound tense. See Arregi 2000 for details.

presented an analysis in which, following Laka 1990 and Arregi 2000, the morphological difference between simple and compound tenses is described in syntactic terms: presence versus absence of movement of the verb to T. There is, however, an alternative analysis in which *all* tenses involve movement to T. This analysis was first proposed by Ortiz de Urbina (1989) (see also Ortiz de Urbina 1995), and is further defended in G. Elordieta 1997b and A. Elordieta 2001. These authors provide several arguments in favor of this analysis, and these are discussed in §4.6.2 below. As I show there, most of these arguments show that the participle and the auxiliary form a single phonological word. However, analyzing these facts in terms of syntactic movement of the verb to T in both simple and compound tenses does not account for the fact that they form separate words morphologically. All the facts are compatible, however, with an analysis, such as the one defended here, in which the participle and auxiliary are separate words in the syntax, but which are joined into a single word at PF. This can be achieved with the operation *Morphological Merger* (see Marantz 1988, Halle and Marantz 1993, Bobaljik 1996, Embick and Noyer 2001). In the morphological component, merger joins two separate adjacent heads and forms a single complex head. In the case of Basque compound tenses, it can be represented as follows:

(7) *Merger of participle and auxiliary*

$$[V+v+Asp] [Aux+T] \rightarrow [V+v+Asp+Aux+T]$$

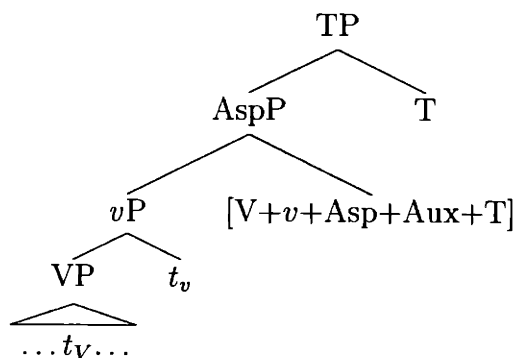

Following the references cited above, I take morphological merger to be a lowering operation (as opposed to syntactic head movement, which is raising). As shown in (7), merger applies after the auxiliary has been adjoined to T. Thus, the present analysis captures all the relevant facts: the participle and auxiliary are morphologi-

cally separate words due to the absence of movement of the verb to T, and they are phonologically a single word due to merger applying late at PF.

#### 4.2.2 The Syntax of Arguments

In Basque transitive sentences, the ‘neutral’ word order is SOV.<sup>6</sup>

- (8) a. Mirenek Jon ikusi rau.  
 Miren.E Jon.A see.PRF Aux.PR  
*Miren has seen Jon.*
- b. Jonek liburo bat idatziko rau.  
 Jon.E book a.A write.FUT Aux.PR  
*Jon will write a book.*

I assume that the object is generated inside the VP, and the subject in the specifier position of *v*. Given the basic clausal structure presented in the previous section, transitive clauses have the following structure, abstracting away from movements:<sup>7</sup>

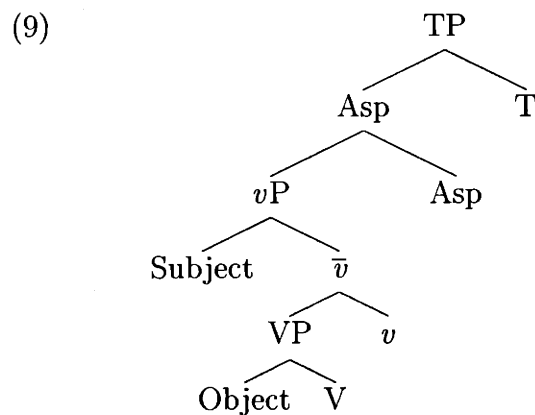

In ditransitive sentences, the indirect object is between the subject and the object:

- (10) a. Nik Mirenei kotxe bat emon netzan.  
 I.E Miren.D car a.A give.PRF Aux.PST  
*I gave Miren a car.*

<sup>6</sup>Given that word order is quite free in Basque, the notion ‘neutral word order’ is crucial. For present purposes, sentences with neutral word order are understood as those which can be uttered ‘out of the blue’, without a previous linguistic context. See §5.7 for discussion.

<sup>7</sup>I discuss the possibility of movement of the subject to [Spec, TP] in §4.5.1.

- b. Mirenek Jonei beran etxi erakutzi tza.  
 Miren.E Jon.D her house.A.SG show.PRF Aux.PR  
*Miren has shown Jon her house.*

I assume that ditransitive sentences have a VP-shell structure (cf. Larson 1988), where the direct object is generated as the complement of the lower V, and the indirect object is in the specifier position of the higher V:<sup>8</sup>

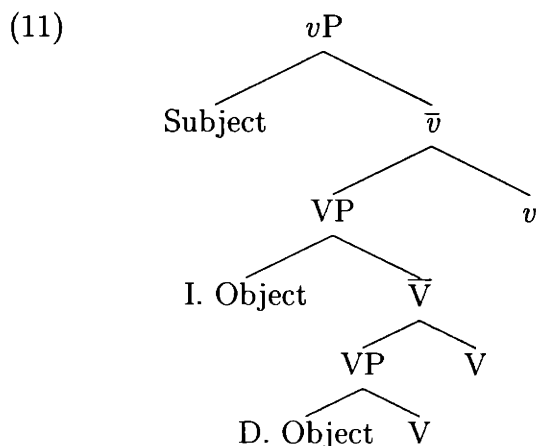

As can be seen in all the examples given so far, transitive subjects are inflected for ergative case, direct objects are absolutive, and indirect objects are dative. Furthermore, the tensed verb agrees with all three types of arguments. In intransitive clauses, the case on the subject depends on what type of argument it is. In unergative sentences, where the subject is an external argument (i.e. generated in [Spec, *v*P]), the subject is ergative (cf. 12). In unaccusative sentences, where the subject is an internal argument (generated as the complement of VP), the subject is absolutive (cf. 13).<sup>9</sup>

- (12) *Unergative verbs*

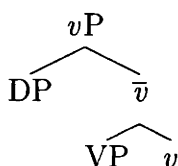

<sup>8</sup>The only crucial part of this structure is that the indirect object is higher than and to the left of the direct object. There are alternative analyses that can account for the same facts. See, among others, Marantz 1993, Pesetsky 1994 and Pykkänen 2002.

<sup>9</sup>There are some exceptions to this generalization. For instance, the subject of *urten* 'leave' is ergative, even though this verb is, in principle, unaccusative.

- a. Jonek jan        dau.  
 Jon.E eat.PRF Aux.PR  
*Jon has eaten.*
- b. Mirenek jolastu    ban        atzo.  
 Miren.E play.PRF Aux.PR yesterday  
*Miren played yesterday.*

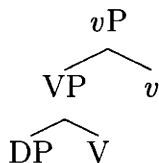
(13) *Unaccusative verbs*

- a. Miren    aia        ra.  
 Miren.A arrive.PRF Aux.PR  
*Miren has arrived.*
- b. Arbol    jausi        san.  
 tree.A.SG fall.PRF Aux.PR  
*The tree fell.*

Even though some unergative verbs are intransitive (cf. 12), in that there is only one overt argument in the clause, most unergative verbs are formed with the verb *ein* and some noun which is realized as a direct object and inflected as absolutive. Sentences containing them are transparently transitive:

- (14) a. Mirenek an    fabrikan        biarra        etxen    dau.  
 Miren.E there factory.ALL.SG work.A.SG do.IMP Aux.PR  
*Miren works in that factory.*
- b. Jonek farre    eiñ        ddau.  
 Jon.E laugh.A do.PRF Aux.PR  
*Jon has laughed.*

In the following section, I apply the NSR to the structures discussed in this section, and show that it correctly predicts the placement of sentence stress in them.

### 4.3 Sentence Stress

In §3, I proposed the following formulation of the NSR:

(15) *The Nuclear Stress Rule*

- a. Edge-marking: RRR:  $\emptyset \rightarrow ) / * \_ ]$   
 b. In the following configuration:

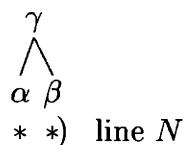

The grid element corresponding to the head of  $\gamma$  is the head of the foot iff the head of  $\gamma$  is branching.

In this version of the NSR, the internal structure of a phrase is crucial to the placement of stress within it. However, in §2 we saw that Ondarroa Basque has phrase level stress rules which are not structure dependent. For instance, the following DPs, which have different internal structures, have the same stress pattern:

- (16) a. [ [ nire aman ] lagune ]    nire aman lagune  
           my mother.G.SG friend.A.SG  
           *my mother's friend*
- b. [ nire [ lagun andixe ] ]    nire lagun andixe  
           my friend big.A.SG  
           *my great friend*

Thus, it might seem that the NSR does not apply in Ondarroa Basque. In this section, I argue that this is not the case. The data presented below provide evidence that the NSR does apply in Basque, but that certain parts of the syntactic tree are invisible to it. In particular, the internal structure of DP is not accessible to the NSR. Inside DP, prominence is determined by the stress rules proposed in §2. In other words, DPs are treated as 'minimal units' for the purposes of the NSR. Accordingly, in all the examples examined below, all DPs are considered as if they were words for the purposes of the NSR. The question of parametric variation, (i.e. the exact difference between English and Basque in terms of the domains in which the NSR applies) is dealt with in §4.7.

The placement of sentence stress in Ondarroa Basque (and all other pitch accent dialects) follows this generalization:<sup>10,11</sup>

- (17) Sentence stress is on the rightmost constituent to the left of the verb.

Given the head-final nature of Basque syntax, it is easy to see how the NSR can account for this generalization. Given the basic clause structure adopted in the previous section,

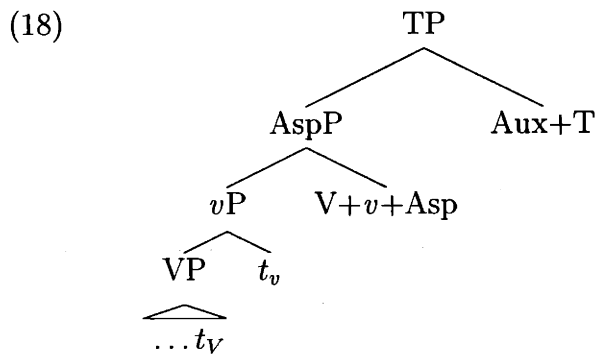

the NSR predicts that some constituent inside *vP*, if present, bears sentence stress. First, specifiers of *Asp* and *T* cannot bear sentence stress, since the NSR states that a specifier (the sister of a branching head) is less prominent than its sister. Furthermore, the participle and auxiliary do not bear sentence stress, since the NSR gives more prominence to their sister (i.e. a complement is more prominent than the head it is a complement to). By the same reasoning, if there is more than one constituent inside *vP*, the rightmost one is the one bearing sentence stress, since it is contained in *VP*, the complement of *v*. Thus, the NSR derives generalization (17). In the rest of this section, I illustrate this generalization with the major sentence types presented in the previous section, and show in more detail how the NSR derives the relevant facts.

<sup>10</sup>This generalization is somewhat imprecise, since it is not clear what is meant by ‘the verb’, and it has nothing to say about sentences in which the leftmost constituent is to the left of the verb. Needless to say, I only take this to be a rough generalization. As I argue in this chapter, what accounts for the placement of sentence stress is the NSR.

<sup>11</sup>This section and the following ones contain fairly detailed descriptions of all the relevant facts. A good source which contains a fair amount of descriptive detail is Hualde, Elordieta, and Elordieta 1994 (§§2.8, 4.1). Although this work is a grammar of the variety spoken in the neighboring town of Lekeitio, most of the relevant facts are the same, *modulo* differences in the stress rules discussed in §2 in this thesis.

In transitive clauses, with a neutral SOV order, sentence stress is on the object:<sup>12</sup>

- (19) a. Mirenek **Jón** ikusi rau.  
 Miren.E Jon.A see.PRF Aux.PR  
*Miren has seen Jon.*
- b. Jonek **libúro bat** idatziko rau.  
 Jon.E book a.A write.FUT Aux.PR  
*Jon will write a book.*

Consider (19a) in more detail:<sup>13</sup>

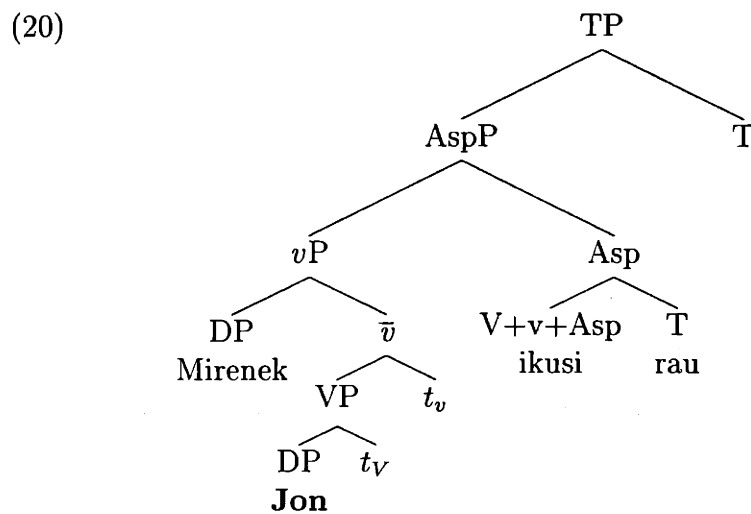

In the  $\bar{v}$  cycle, the following grid is derived:<sup>14</sup>

- (21)
- |             |        |
|-------------|--------|
| *           | line 4 |
| - * ——— )   | line 3 |
| - * ——— )   | line 2 |
| [[Jon t] t] |        |

Since the object *Jon* is the only constituent inside  $\bar{v}$ , it receives highest prominence in this constituent. On the next cycle,  $vP$ , there are two overt constituents (*Mirenek* and

<sup>12</sup>In all the examples below, bold face is used to mark the constituent with sentence stress. Furthermore, where relevant, and acute accent mark (´) is placed on the specific vowel that bears sentence stress.

<sup>13</sup>In this structure, I have taken into account the fact that the participle and the auxiliary form a single word due to morphological merger (see §4.6.2).

<sup>14</sup>In the grids illustrating the NSR, in Basque, the lowest line used is line 2. As shown in §2, this is the highest line that stress projects to at the phrase level in Basque.

*Jon*. First, the SEC assigns equal prominence to both,<sup>15</sup> and then the NSR assigns more prominence to *Jon* since it is contained in the branching head of *vP* (i.e. more prominence is given to the sister of the specifier):

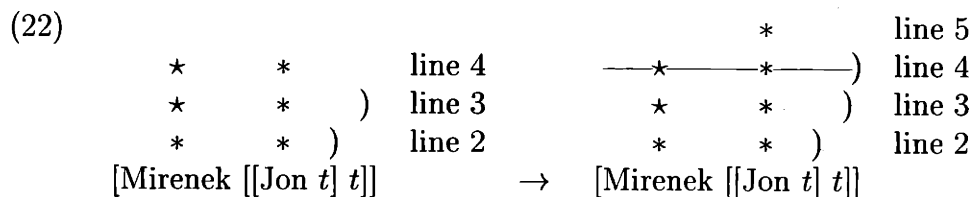

The rest of the sentence is straightforward: since *vP* is the complement of *Asp*, and *AspP* is the complement of *T*, *vP* receives higher prominence than the participle and auxiliary. The final grid is as follows:

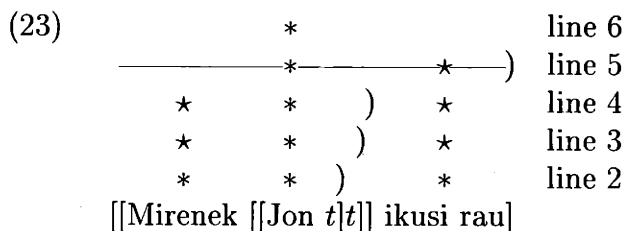

Thus, the NSR correctly predicts that the object has sentence stress in SOV sentences.<sup>16</sup>

This first example also helps raise another question that was not addressed in the previous section. So far, I have assumed that there is no (obligatory) movement of the subject to [Spec,TP]. With respect to the NSR, it is not clear whether this movement occurs in transitive sentences. Regardless of whether the subject *Mirenek* in (19a) moves to [Spec,TP] or stays in [Spec,*vP*], sentence stress is (correctly) predicted to be on the object *Jon*. Nevertheless, as we will see below, the placement of sentence stress does have something to say about this movement. This topic is dealt with in §4.5, where we explore the relation between movement and the NSR.

<sup>15</sup>Recall from §3 is crucial in the computation of stress. It ensures that the NSR applies non-vacuously in cycles containing more than one stressed word, and removes the negative effects that depth of embedding has on the application of the NSR.

<sup>16</sup>In the resulting grid, the verb complex *ikusi rau* is more prominent than the subject *Mirenek*. Although speakers have a clear intuition about which constituent has primary stress in the sentence, this is not the case for lesser levels of stress. Nevertheless, phrases without sentence stress are pronounced with clearly defined intonation patterns. These do not depend on the metrical grid. For details, see Hualde et al. 1994, Elordieta 1997a.

In ditransitive sentences, whose neutral order is S-IO-DO-V, sentence stress is also on the direct object:

- (24) Nik Mirenei **kótxe bat** emon netzan.  
 I.E Miren.D car a.A give.PRF Aux.PST  
*I gave Miren a car.*

As shown in the previous section, ditransitive clauses have the following structure (Asp and T have been omitted):

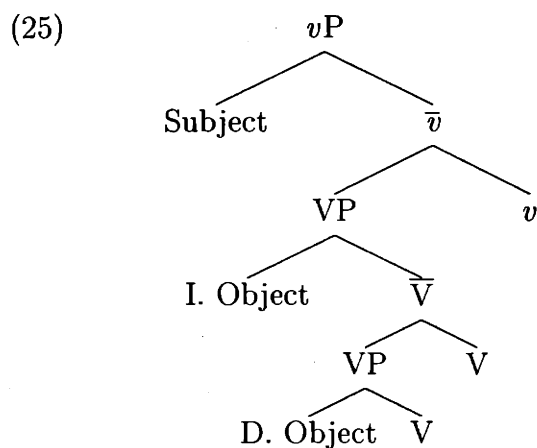

As predicted by the NSR, the direct object is the most prominent constituent in  $vP$ , since it is the complement of the complement of the complement of  $v$ . As in transitive clauses, this makes the direct object the constituent with sentence stress.

In unaccusative sentences, the only argument of the verb has sentence stress:

- (26) **Míren** aia ra.  
 Miren.A arrive.PRF Aux.PR  
*Miren has arrived.*

The NSR correctly predicts this fact, given the structure assumed in the previous section:<sup>17</sup>

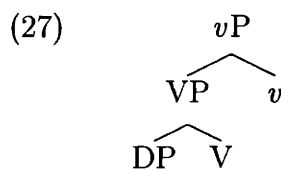

<sup>17</sup>In this structure, the absolutive argument does not move to [Spec, TP]. This might be seen as contradicting Ortiz de Urbina's (1989) arguments that this movement does occur. See footnote 27 on page 131 below for discussion.

Since the internal argument is the only constituent inside the *vP*, it receives sentence stress.

As we saw in §4.2.2, most unergative clauses in Basque are transparently transitive:

- (28) Mirenek an fabrikan **biarra** etxen dau.  
 Miren.E there factory.ALL.SG work.A.SG do.IMP Aux.PR  
*Miren works in that factory.*

As expected, sentence stress is on the object, as in any other transitive sentence. However, we also saw in §4.2.2 that a reduced number of unergative verbs, such as *jolastu* ‘play’, are not transparently transitive:

- (29) Mirenek **jolastú ban** atzo.  
 Miren.E play.PRF Aux.PR yesterday  
*Miren played yesterday.*

As shown in this example, sentence stress is on the verb (or rather, on the word formed by the participle and the auxiliary). This fact might seem problematic, given the structure assumed for these verbs in §4.2.2:

- (30) *Unergative verbs*

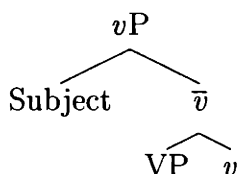

Since the subject is in [Spec, *vP*] and both V and *v* move out of *vP*, it seems that we wrongly predict that sentence stress should be on the subject.

One might be tempted to solve this problem by assuming that the ergative subject moves to [Spec,TP]. In the resulting structure, the verb would be assigned sentence stress. However, as I argue in §4.5 below, there is evidence that this movement is at best optional in Basque. Thus, this is not a possible solution.

I propose that the solution can be found once we look at the internal structure of unergative verbs in more detail. First, I follow Hale and Keyser 1993 in assuming that *all* unergative verbs are transitive:

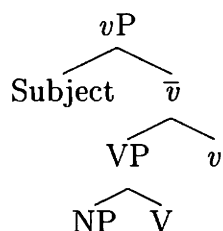
(31) *Unergative verbs*

In most cases (cf. 28), the internal argument is realized as an absolutive DP in Basque. The question is how this structure is realized morphologically in cases like (29) where there is no overt object. I would like to propose that this is the result of morphological merger of NP and the verb (along with all the functional heads that are attached to it after head movement and merger of the participle and auxiliary):

(32) *Merger in unergative verbs:*

$$[N] [V+v+Asp+Aux+T] \rightarrow [N+V+v+Asp+Aux+T]$$

As a result of merger, the noun and verb are realized as a single word.<sup>18</sup> Since merger is lowering, the resulting word is assigned more prominence than the subject in [Spec, *vP*], and thus has sentence stress.

All the examples seen so far contain verbs in compound tenses. The prediction made for sentences with simple tenses are basically the same, but there are certain complicating factors. Simple tense verbs behave as phrasal clitics, as illustrated in the following examples:

- (33) a. Jón da. Jónda  
 Jon.A is  
*It's Jon.*
- b. Jon dátor. Jondator  
 Jon.A comes  
*Jon is coming.*
- c. Oixe gixona rátor. Oixe gixona rator  
 that.A man.A.SG comes  
*That man is coming.*

<sup>18</sup>In particular, in this context, V is realized as  $\emptyset$ , rather than *ein* 'do', which is the verb that is used when there is no merger (cf. 28).

- (34) a. Jonek bat takar. bat takar  
 Jon.E one.A has  
*Jon has one.*
- b. Jonek neure ixena raki. neure ixena raki  
 Jon.E my name.A.SG knows  
*Jon knows my name.*

In all these examples, the preverbal phrase and the verb form a single phrase with respect to stress, as witnessed by the fact that the string starts with a rise in pitch and ends with a fall (see §2). If they formed separate phrases, we would expect each to have a separate rise and fall. Since the verb and the preverbal phrase do not necessarily form a phrase in the syntax, I propose that this is the result of morphological merger, which adjoins the simple tense verb to the preceding phrase:<sup>19</sup>

- (35) [XP] [V+v+Asp+T] → [XP XP V+v+Asp+T]

For instance, in the case of (34b), the resulting structure after merger would be:

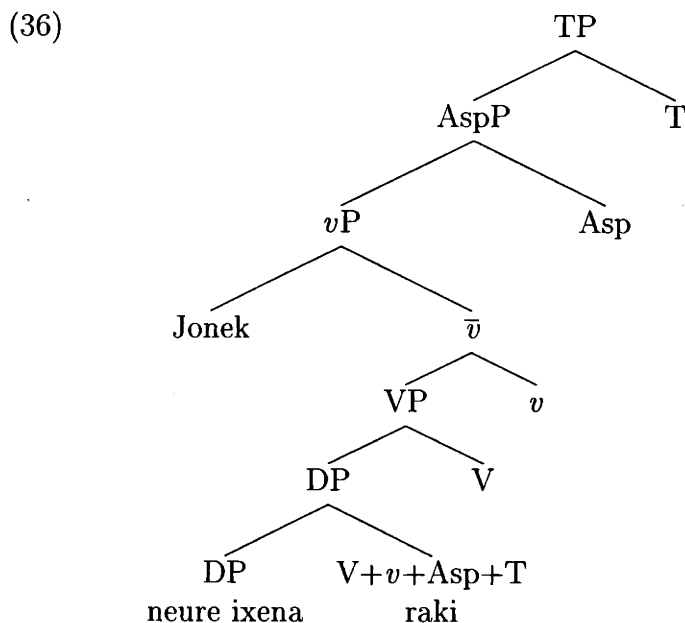

After merger, the object and the tensed verb form a single phrase. This phrase is the complement of V, so the NSR predicts that it has sentence stress. This prediction is

<sup>19</sup>This operation is different from the merger operation proposed in §4.6.2, which joins the participle and auxiliary in compound tenses into a single word. Apart from accounting for the stress facts discussed above, this rule also accounts for the fact that the verb in simple tenses cannot appear first in the clause.

confirmed by the data: in all the examples in (33–34), sentence stress is on the phrase formed by the verb and the preverbal constituent.<sup>20</sup>

Thus, the NSR predicts correctly the placement of sentence stress in the major sentence types reviewed in §4.2. In the next section, I discuss the behavior of adverbials with respect to the NSR.

#### 4.4 Adverbials and the NSR

The order of adjuncts in the clause seems to be quite free. As exemplified below with *atzo* ‘yesterday’ and *askotan* ‘often’, they can appear in different positions in the clause:<sup>21</sup>

- (37) a. (Atzo) Jonek (atzo) liburo bat irakurri (\*atzo) ban (atzo).  
 yesterday Jon.E book a.A read.PRF Aux.PST  
*Jon read a book yesterday.*
- b. (Askotan) Mirenek (askotan) liburuk irakurten (\*askotan)  
 Often Miren.E book.A.PL read.IMP  
 dau (askotan).  
 Aux.PR  
*Miren often read books.*

Native speakers seem to have no preference for any one of the possible word orders shown. I assume that these phrases can be base-generated as adjuncts to any of the projections in the basic clause structure (VP, *v*P, AspP, TP). This derives the fact that, despite their freedom in word order, they cannot appear between the object and the verb in neutral sentences.<sup>22</sup> The fact that they cannot appear between the participle and the auxiliary is a consequence of morphological merger, as argued for in §4.6.2.

<sup>20</sup>In the case of the intransitive sentences in (33), this is trivially true, since it is the only phrase present in the structure.

<sup>21</sup>I am including here only the facts about adjuncts that are relevant for the next section. Some of the data below are adapted from A. Elordieta 2001, to which the reader is referred to for further details and discussion.

<sup>22</sup>That is, they can appear in this position only in sentences which are not possible ‘out of the blue’. Given the structure assumed here, the only way that they can surface in this position is by movement of the object to the left of them. As will be shown in §4.5, this movement results in sentences which are not neutral.

The behavior of these adverbials with respect to sentence stress is as expected:

- (38) (Atzo) Jonek (atzo) **libúro bat** irakurri ban (atzo).  
 yesterday Jon.E book a.A read.PRF Aux.PST  
*Jon read a book yesterday.*

Since phrases of this type are adjuncts, the NSR predicts that they do not have sentence stress. Consider the case in which *atzo* is between the subject and the object. The structure of *vP* is as follows:

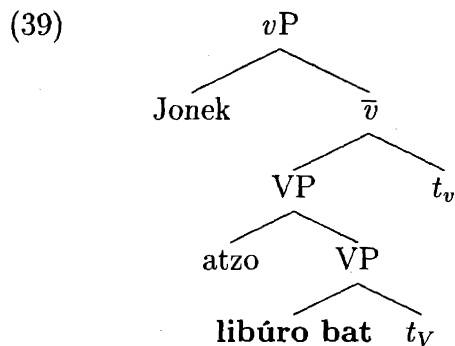

The sister of the adverbial *atzo* is a branching head, and thus the NSR assigns more prominence to it than to the adverbial, resulting in sentence stress on the object. In general, adjuncts to XPs are predicted to have the same status as specifiers, since their sisters are branching heads.

On the other hand, as shown in A. Elordieta 2001, certain ‘short’ manner adverbs, such as *txarto* ‘badly’ and *gogor* ‘hard’ seem to have a fixed position in the clause. In neutral sentences, there is a preference to place them left-adjacent to the verb (the participle in compound tenses):

- (40) a. Jonek atzanengoko asterketi txarto ei ban.  
 Jon.E last exam.A.SG badly do.PRF Aux.PST  
*Jon did the last exam badly.*
- b. Athletic Real Madriden kontra gogor jolasten dau.  
 Athletic Real Madrid.G against hard play.IMP Aux.PR  
*Athletic plays hard against Real Madrid.*

Unlike other adverbs, placing these adverbs in some other position in the clause seems to result in sentences which may not be uttered ‘out of the blue’. I assume, following

A. Elordieta 2001, that these adverbs are generated as complements of the lowest verb in a VP-shell structure (cf. Larson 1988):

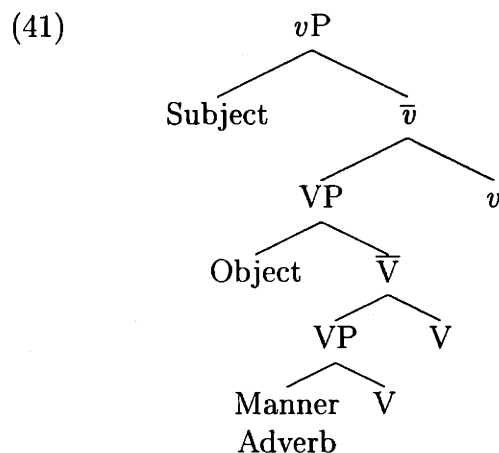

This accounts for the fact that, in the neutral word order, these adverbs appear between the object (if present) and the verb.

Given their position in the clause, these adverbials typically have sentence stress:

- (42) Jonek atzanengoko asterketi **txárto** ei ban.  
 Jon.E last exam.A.SG badly do.PRF Aux.PST  
*Jon did the last exam badly.*

The manner adverbial is the complement of the complement of the complement of *v*, and thus is the most prominent constituent in *vP*, which means that it has sentence stress.

All the examples we have seen so far involve unmarked word orders. In the following section, I discuss the predictions made by the NSR in sentences with marked word orders, in which one or more constituent has moved from its base position.

#### 4.5 The NSR and Movement

In the previous section, all the examples contained some instance of movement: both syntactic head movement and morphological merger. However, none of these movements had a visible effect on the placement of sentence stress, since all the sentences contained some constituent in VP which would end up with sentence stress regardless

of the presence or absence of head movement or merger.<sup>23</sup> In this section, I examine two types of movement, left and right dislocation, both of which have a predictable effect on the placement of sentence stress.

The basic idea explored in this section is that, given that the NSR is structure sensitive, any movement has the potential to alter the position of sentence stress. This idea is illustrated in several works which defend some version or other of a structure sensitive NSR (see, among others, Cinque 1993, Zubizarreta 1998, Reinhart 1995, Ishihara 2001 and Neeleman and Reinhart 1998.)<sup>24</sup>

In Basque, there seem to be two main types of movement which alter the unmarked word order discussed in §4.2: left and right dislocation. Although these movements have very specific and distinct syntactic, semantic and discourse properties, in this section I discuss only their effect on the placement of sentence stress. Their effects on other parts of grammar constitute the main topic of chapters 5–5.10.

#### 4.5.1 Left Dislocation

Left dislocation is illustrated in the following example, where the object is moved to the left of the subject:<sup>25</sup>

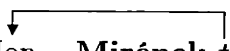
- (43)  Jon **Mirének** *t* ikusi rau.  
 Jon.A Miren.E see.PRF Aux.PR  
*Jon, Miren has seen.*

I assume that left dislocation results in adjunction to TP:

<sup>23</sup>The only exception is merger in simple tenses, which joins the verb and the preverbal DP into a single phrase. The resulting phrase has sentence stress. However, even if merger did not apply, the preverbal phrase would still receive sentence stress.

<sup>24</sup>In fact, this is true of any version of the NSR, including those that are based on word order. However, this is more visible in structure dependent versions of the NSR. For instance, in Halle and Vergnaud's (1987) NSR for English (cf. §3.2), where stress is always rightmost, movement of  $\beta$  to the left of  $\alpha$  in the structure [ $\alpha \beta$ ] has an effect on stress, but movement of  $\beta$  to the right does not.

<sup>25</sup>For ease of exposition, the English translations to the examples also have the relevant constituent left dislocated. As shown in §5, left dislocation is very similar to topicalization in English, in that both create topics. Thus, these translations give an idea of the discourse function of the dislocated elements. In some cases (such as 46b below) this might result in English sentences that are far from ideal.

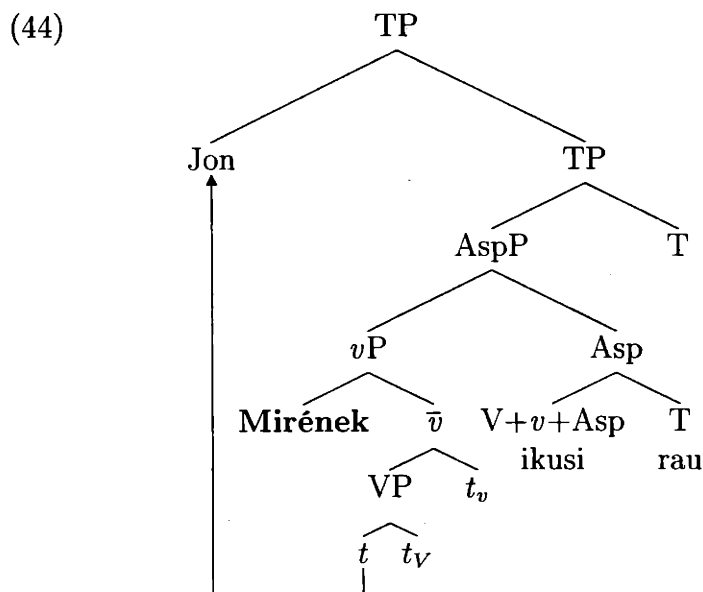

What is crucial in this example is the effect that movement of the object has on the placement of sentence stress. If there is no left dislocation, the NSR assigns sentence stress to the object *Jon* (cf. 19a). However, as shown in (43), after movement of the object, sentence stress is on the subject *Mirenek*. This is precisely what the NSR predicts, since the subject is the only overt constituent left inside *vP*. In the left-dislocated position, the object *Jon* cannot have sentence stress: it is the sister of the branching head TP, which means that TP must contain the constituent with sentence stress (i.e. *Mirenek*). The resulting grid is as follows:<sup>26</sup>

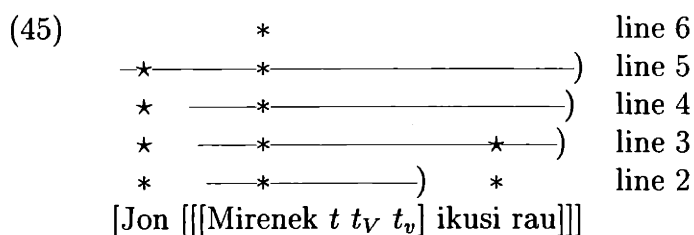

Sentences with OSV order also help in answering the question of movement of the subject to [Spec,TP]. Unlike other clauses seen so far, the hypothesis that the subject does not (obligatorily) raise to [Spec,TP] is crucial in this case. If this movement occurred, the subject would never receive sentence stress, which is contrary to fact.<sup>27</sup>

<sup>26</sup>Note that the NSR does not apply in the VP and  $\bar{v}$  cycles because there is no overt constituent it could apply to.

<sup>27</sup>Ortiz de Urbina (1989) gives some evidence which, he argues, shows that subjects are in [Spec,TP] ([Spec,IP] in his framework). The main objective of his discussion is to argue that Basque

Left dislocation is illustrated further in the following examples:

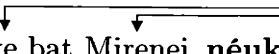
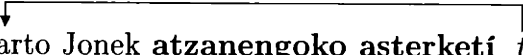
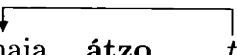
- (46) a.  Kotxe bat **nik** **Mirénei** t emon netzan.  
 car a.A I.E Miren.D give.PRF Aux.PST  
*A car, I gave Miren.*
- b.  Kotxe bat Mirenei **néuk** t t emon netzan.<sup>28</sup>  
 car a.A Miren.D I.E give.PRF Aux.PST  
*A car, Miren, I gave.*
- c.  Txarto Jonek **atzanengoko** **asterketí** t ei ban.<sup>29</sup>  
 badly Jon.E last exam.A.SG do.PRF Aux.PST  
*Badly, Jon did the last exam.*
- d.  Amaia **átzo** t aia san.  
 Amaia.A yesterday arrive.PRF Aux.PST  
*Amaia arrived yesterday.*

In (46a), the direct object is left dislocated in a ditransitive sentence. The result is sentence stress on the indirect object. The structure of *vP* in the resulting structure is the following:

---

sentences do not have a flat structure, by showing that there are several subject/object asymmetries that can easily be explained in structural terms. In particular, he shows that the subject must be structurally higher than the object. For instance, he shows that a subject can bind an object anaphor, but not the other way around. In his framework, where external arguments are not generated inside VP/*vP* (his book is based on his 1986 doctoral dissertation), this means that the subject has to be in [Spec, IP]. Although the arguments are convincing, this is not a necessary conclusion given current assumptions: these subject/object asymmetries can be seen the result of the fact that the subject is generated as the specifier of *vP*, and that the object is inside VP.

<sup>28</sup>As discussed below, in this sentence, the first person singular subject pronoun *neuk* has sentence stress. First and second person pronouns have special forms when contained in the constituent with sentence stress. Thus, in (46a) where it does not have sentence stress, it is realized as *nik*. Something similar occurs with demonstratives. For instance, the distal demonstrative *ori* is realized as *oixe* when it is in the constituent with sentence stress (cf. 33c).

<sup>29</sup>As shown in §5, left dislocated phrases are interpreted as topics. This makes left dislocation of *txarto* 'badly' in this example somewhat odd if the proper context is not given. For reasons that will become clear in that chapter, this example is appropriate in a context in which *txarto* is uttered in a context in which the relevant question is which exam Jon did badly and which exam he did well. This sentence asserts that he did the last exam (as opposed to others) badly.

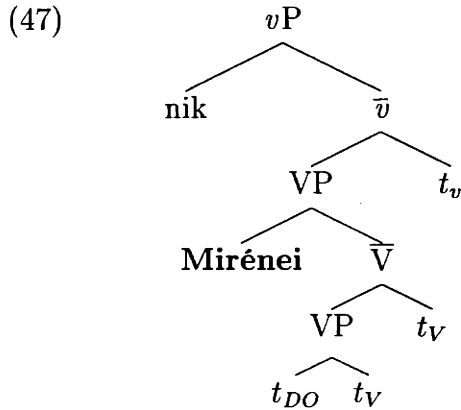

After movement, the only overt constituent left inside the higher VP is the indirect object *Mirénei*. Since the higher VP is the complement of *v*, the NSR correctly predicts that *Mirénei* is the most prominent constituent in *vP*, and consequently it has sentence stress. Sentence (46b) is the same as (46a), except that both the direct and indirect objects are moved to the left of the subject. In the resulting structure, the subject *neuk* is the only overt constituent inside *vP*, which means that it receives sentence stress.

Example (43c) contains the adverbial *txarto* ‘badly’. As we saw in §4.2.2, adverbials of this type are generated in the lowest VP in a VP-shell structure (cf. 41), which means that in the unmarked order, they appear to the left of the verb, and receive sentence stress. In (43c), however, this adverbial is left dislocated. The result is sentence stress on the object, since it is the only overt constituent inside VP.

Finally, the unaccusative sentence in (43d) contains the adverbial *atzo* ‘yesterday’, which, as shown in §4.2.2, can be adjoined to any of the projections in the basic clause structure (VP, *vP*, AspP, TP). The internal argument *Amaia* is left dislocated from inside the VP to the left of the adverbial. In the resulting structure, *atzo* is assigned sentence stress by the NSR:

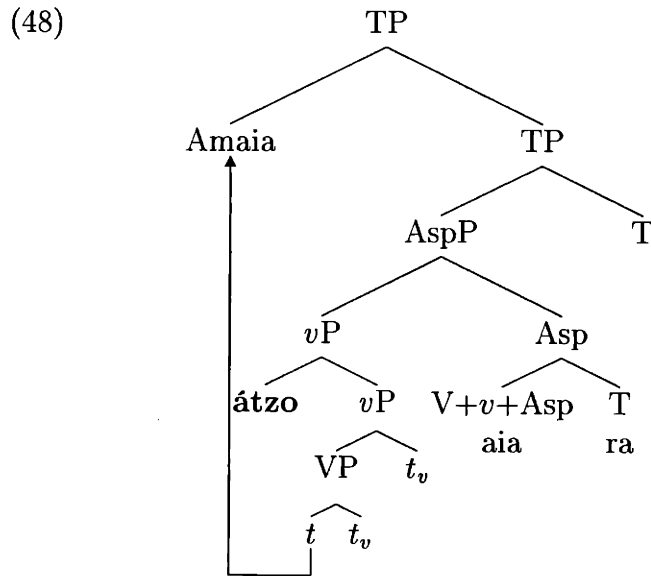

This is the case if the adverbial is adjoined to VP or  $vP$ . On the other hand, if it is adjoined higher (AspP or TP), the result would be sentence stress on the verb. This prediction is borne out: this sentence can also be pronounced with sentence stress on the verb. This type of stress pattern is discussed in §4.5.3 below.

#### 4.5.2 Right Dislocation

Right dislocation has basically the same effects as left dislocation on the NSR: when a constituent that would have sentence stress in the unmarked order moves, some other constituent can end up with sentence stress. Consider the following example, which is parallel to the left dislocation example in (43):

- (49) **Miréne**k  $t$  ikusi rau Jon.  
 Miren.E see.PRF Aux.PR Jon.A  
*Miren has seen Jon.*

I assume that right dislocation, like left dislocation, results in adjunction to TP:

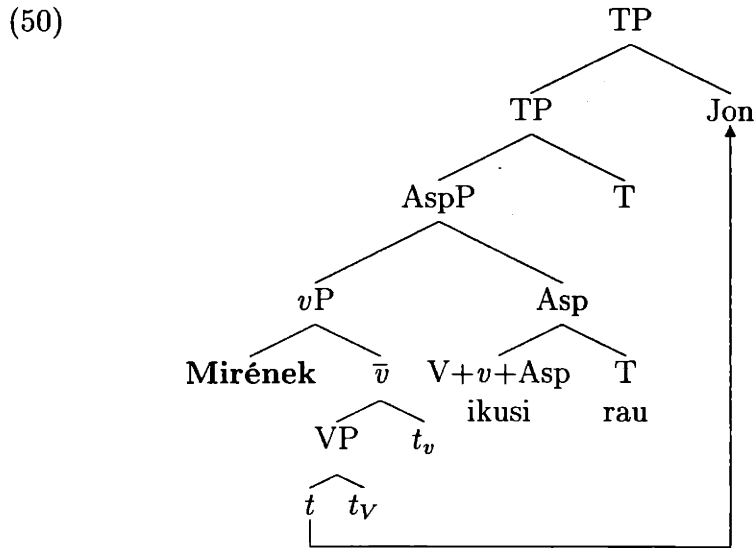

Just as in left dislocation, movement of the object *Jon* to TP results in the subject *Mirének* having sentence stress.

The following examples of right dislocation are parallel to the left dislocation ones in (46):

- (51) a. Nik **Mirénei** *t* emon netzan kotxe bat.  
 I.E Miren.D give.PRF Aux.PST car a.A  
*I gave Miren a car.*
- b. Néuk *t t* emon netzan kotxe bat Mirenei.  
 I.E give.PRF Aux.PST car a.A Miren.D  
*I gave Miren a car.*
- c. Jonek **atzanengoko asterketí** *t* ei ban txarto.  
 Jon.E last exam.A.SG do.PRF Aux.PST badly  
*Jon did the last exam badly.*
- d. **Átzo** *t* aia san Amaia.  
 yesterday arrive.PRF Aux.PST Amaia.A  
*Amaia arrived yesterday.*

In (51a) the direct object is right dislocated, resulting in sentence stress on the indirect object. In (51b), both objects are moved, so that the subject has sentence stress. In (51c), the preverbal adverb is right dislocated, and the object has sentence stress.

Finally, in (49d), the unaccusative subject *Amaia* moves to the right, leaving the adverbial *atzo* in a position to be assigned sentence stress.

To sum up so far, both left and right dislocation can have the same predictable effect on sentence stress. They both involve movement of some constituent to a high position in the clause (adjunction to TP), which results in sentence stress on some constituent which would otherwise not have sentence stress.

### 4.5.3 Sentence Stress on Verbs

In all the examples of movement seen so far, movement of some XP results on the assignment of sentence stress to some other XP. However, both left and right dislocation can also result in sentence stress on verbs. In this section, I discuss sentences of this type, arguing that the NSR makes correct predictions in this case too.

That movement of some XP can result in sentence stress on the verbal complex is seen most clearly in unaccusative sentences:

- (52)  $\overbrace{t \text{ Aiá } \text{ ra } \text{ Amaia.}}^{\downarrow}$   
           arrive.PRF Aux.PR Amaia.A  
           *Amaia has arrived.*

In this example, the internal argument *Amaia* is right dislocated, leaving the verbal complex as the only constituent inside TP. The result is sentence stress on the verbal complex:

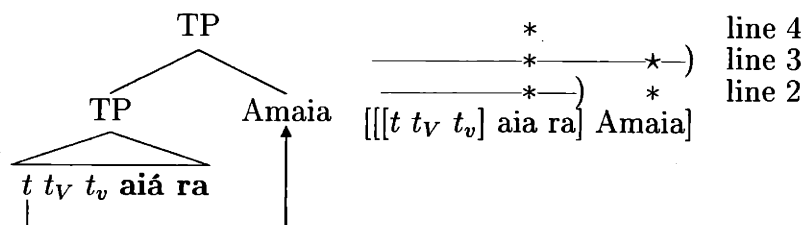
- (53) 

Right dislocation of both the subject and object in transitive sentences can have the same effect:

- (54) a.  $\overbrace{t t \text{ Ikusí } \text{ rau } \text{ Mirenek Jon.}}^{\downarrow}$   
           see.PRF Aux.PR Miren.E Jon.A  
           *Miren has seen Jon.*

- b.  $\overbrace{t\ t\ \text{Ikusí}\ \text{rau}\ \text{Jon}\ \text{Mirenek.}}^{\text{see.PRF Aux.PR Jon.A Miren.E}}$   
*Miren has seen Jon.*

Similarly, left dislocation can also result in sentence stress on the verbal complex:

- (55) a.  $\overbrace{\text{Amaia}\ t\ \text{aiá}\ \text{ra.}}^{\text{Amaia.A arrive.PRF Aux.PR}}$   
*Amaia has arrived.*
- b.  $\overbrace{\text{Mirenek}\ \text{Jon}\ t\ t\ \text{ikusí}\ \text{rau.}}^{\text{Miren.E Jon.A see.PRF Aux.PR}}$   
*Miren has seen Jon.*
- c.  $\overbrace{\text{Jon}\ \text{Mirenek}\ t\ t\ \text{ikusí}\ \text{rau.}}^{\text{Jon.A Miren.E see.PRF Aux.PR}}$   
*Miren has seen Jon.*

For instance, movement of *Amaia* in (55a) leaves the verbal complex as the only constituent inside TP, which means that it has sentence stress:

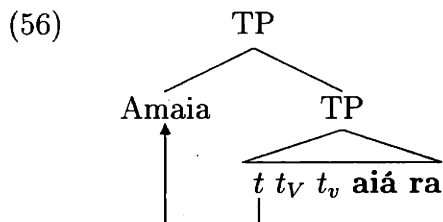

Similarly, in the transitive sentences in (55b–c), left dislocation of both the subject and the object results in sentence stress on the verbal complex.

The following examples show that, as expected, when there is both left and right dislocation in the same clause, the result can also be sentence stress on the verbal complex:

- (57) a.  $\overbrace{\text{Mirenek}\ t\ t\ \text{ikusí}\ \text{rau}\ \text{Jon.}}^{\text{Miren.E see.PRF Aux.PR Jon.A}}$   
*Miren has seen Jon.*
- b.  $\overbrace{\text{Jon}\ t\ t\ \text{ikusí}\ \text{rau}\ \text{Mirenek.}}^{\text{Jon.A see.PRF Aux.PR Miren.E}}$   
*Miren has seen Jon.*

#### 4.5.4 Interim Conclusion

In this section, I have argued that the NSR proposed in §3 provides a satisfactory account of the distribution of stress in sentences. To the extent that the underlying assumptions about the structure of sentences in Basque are correct, this provides further support for the version of the NSR defended in this thesis. In the following section, I discuss some of these assumptions, arguing that they are correct.

#### 4.6 Right Dislocation, Stress, and Verb Movement

In §§4.5.2–4.5.3, we saw several sentences where one or more XPs appear to the right of the verb. For instance, in the following example, the object is to the right of the verbal complex:

- (58)  $\overbrace{\text{Miréne}k \ t \ \text{ikusi} \ \text{rau} \ \text{Jon.}}^{\text{verb complex}}$   
 Miren.E see.PRF Aux.PR Jon.A  
*Miren has seen Jon.*

The hypothesis that sentences of this type involve rightward movement is crucial in order to explain the sentence stress facts. However, A. Elordieta (2001) claims that these sentences do not involve rightward movement. Rather, they are the result of head movement of the verbal complex to the left of the apparently rightward-moved constituent.<sup>30</sup>

- (59) [ Subject [ [V-Aux] [ Object *t*]]]

This structure and the one proposed above are clearly different, and make very different predictions. For instance, they make different predictions with respect to the relative scope of the subject and the object in this sentence. These predictions are, in part, the topic of §5.10. In this section, I concentrate on certain phonological and morphological aspects of this analysis. In particular, §4.6.1 discusses the account of

<sup>30</sup>In fact, this structure is simpler than what A. Elordieta assumes, since movement of the verbal complex is to the head of CP, which, in her analysis is left-headed. This implies that the subject has also moved further up. These details are not important for the purposes of this section.

sentence stress implied by this analysis, which must be clearly different from the one proposed in this thesis. In §4.6.2, I discuss the hypothesis that the verbal complex can undergo head movement.

#### 4.6.1 The NSR and Linear Order

The analysis proposed by A. Elordieta needs a different version of the NSR for Basque. If we applied the version of the NSR proposed in this thesis, sentence stress would be (wrongly) predicted to be on the object, rather than the subject.<sup>31</sup> She proposes (pp. 138–141) that the NSR does not depend on syntactic structure, but on linear order. Her proposal for Basque can be stated as follows:

- (60) In Basque, sentence stress is on the rightmost constituent to the left of the verbal complex.

This generalization captures many of the facts discussed in this chapter. In fact, we started the discussion of sentence stress in Basque in §4.3 precisely with this generalization. However, this generalization does not account for sentences in which the verbal complex has sentence stress:

- (61) a. Mirenek **ikusí** **rau** Jon.  
 Miren.E see.PRF Aux.PR Jon.A  
*Miren has seen Jon.*
- b. **Ikusí** **rau** Mirenek Jon.  
 see.PRF Aux.PR Miren.E Jon.A  
*Miren has seen Jon.*

As shown in §4.5.3, the analysis defended in this chapter accounts for these cases in terms of both left and right dislocation. Under A. Elordieta's analysis, the following amendment to her proposal about sentence stress is necessary:

- (62) In Basque, sentence stress is *on the verbal complex*, or on the rightmost constituent to the left of the verbal complex.

---

<sup>31</sup>This true also for other versions of the NSR which are structure sensitive, such as Cinque's (1993) or Zubizarreta's (1998).

This generalization, together with A. Elordieta's structure for the above sentences, correctly describes all the stress facts discussed in this chapter.<sup>32</sup>

However, this generalization about sentence stress in Basque is just a generalization. In particular, it correctly describes the special status of the verbal complex, but it does not explain why it has a special status. Furthermore, the generalization also contains an unexplained disjunction. The NSR defended in this thesis accounts for all the facts without mentioning explicitly the verbal complex and without disjunctions. In this sense, the NSR explains the generalization needed by A. Elordieta. However, the NSR is not compatible with the analysis of phrases appearing to the right of the verbal complex in terms of leftward movement of the verb. Thus, her analysis relies strongly on arguments against an analysis in terms of rightward movement. These arguments are reviewed in §5.10, where I argue that rightward movement is indeed possible in Basque, thus allowing us to preserve the more principled account of sentence stress proposed in this chapter.

#### 4.6.2 The Morphosyntax of Compound Tenses

As was noted above, A. Elordieta (2001) proposes that phrases appearing to the right of the verbal complex are the result of head movement of the latter to the left of the former:

$$(63) \quad [ \text{Subject} [ \overset{\downarrow}{\text{V-Aux}} [ \text{Object } t ] ] ]$$

In §4.2.1 above, I proposed an analysis in which the participle and the auxiliary (i.e. the verbal complex) do not form a single word in the syntax. However, in A. Elordieta's analysis the assumption that they do form a single syntactic head is crucial, since, in her analysis, the verbal complex undergoes head movement. In this section, I discuss the evidence given by her and others in favor of this assumption, arguing that the analysis proposed here provides a better account of the relevant facts.

---

<sup>32</sup>This is not entirely correct. As we saw in §4.3, the facts are slightly different in sentences with simple tenses, where sentence stress is on a phrase formed by the verb and the preverbal constituent. Sentence stress in this case is neither on the preverbal constituent nor on the verb itself, but on a phrase containing both.

In the analysis of verb movement defended by A. Elordieta, both simple and compound tenses involve movement of the verb all the way up to T:

(64) *A. Elordieta 2001: simple and compound tenses.*<sup>33</sup>

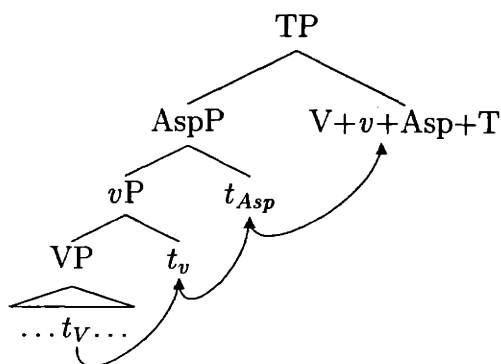

For ease of exposition, I will refer to this account of compound tenses as the ‘alternative analysis’. In the analysis defended here, this structure is assumed only for simple tenses. In compound tenses, the V+v+Asp complex (i.e. the participle) stays in Asp, and an auxiliary is inserted in T. Furthermore, at PF, the participle and the auxiliary form a single word via morphological merger:

(65) *Merger of participle and auxiliary*

$[V+v+Asp] [Aux+T] \rightarrow [V+v+Asp+Aux+T]$

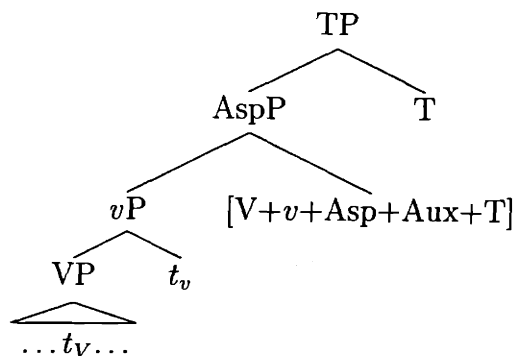

In both analyses, the participle and the auxiliary form a single word at PF. However, this is the result of different operations in the two accounts: head movement in the alternative analysis, and morphological merger in the account defended here.

<sup>33</sup>There are certain details in A. Elordieta’s analysis that have been ignored here. These are not important for the purposes of this section.

Several authors provide evidence in favor of the alternative analysis (see Ortiz de Urbina 1989, 1995, G. Elordieta 1997b and A. Elordieta 2001). The strongest argument put forth in these works has to do with the syntax of focussed and *wh*-phrases. These phrases have to be left-adjacent to the participle-auxiliary complex:

- (66) a. Jonek **ser** irakurri rau?  
 Jon.E what.A read.PRF Aux.PR  
*What has Jon read?*
- b. \*Jonek irakurri rau ser?      c. \*Ser Jonek irakurri rau?
- (67) a. Jonek **liburu<sub>F</sub>** irakurri rau.  
 Jon.E book.A read.PRF Aux.PR  
*Jon read the BOOK.*
- b. \*Jonek irakurri rau liburu<sub>F</sub>.      c. \*Liburu<sub>F</sub> Jonek irakurri rau.

Ortiz de Urbina (1989) proposes that this adjacency requirement has the same analysis as the V2 phenomenon in Germanic languages. Specifically, he proposes that the focussed or *wh*-phrase moves to the specifier position of CP, which, by hypothesis, is left-headed in Basque, and that the participle-auxiliary complex moves to C:

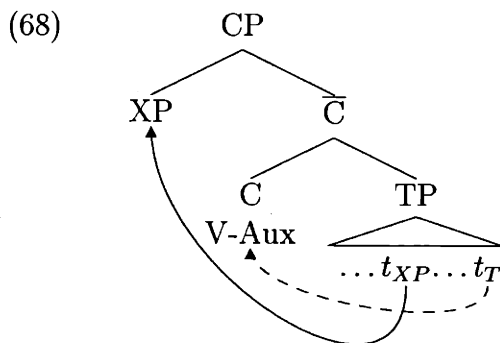

If this analysis is correct, it provides evidence for analyzing the participle-auxiliary complex as forming a single word in the syntax, since it is moving as a unit to a head position (C). However, one of the central theses put forth in this dissertation is that this is in fact *not* the correct syntax for focussed or *wh*-phrases. As argued for in §5, the adjacency between the verb and these phrases needs to be analyzed in very different terms, which do not involve movement of any or the verbs or of the focussed or *wh*-phrase. Rather, it is the consequence of prosodic requirements imposed on these phrases.

Before reviewing the other arguments given by the authors cited above, I would like to point out a problem with this analysis which is not dealt with in detail in those works. In particular, since both simple and compound tenses have the same syntax (they both involve movement to T), it is not clear what accounts for one of the basic morphological differences between the two tenses: simple ones involve a single morphological word, and compound ones two words. In the analysis proposed here, this is a direct consequence of syntax: in simple tenses a single complex head is formed, and in compound tenses, two complex heads are formed. Thus, the account involves a simple one-to-one mapping from (complex) syntactic heads ( $X^{\max}$ ) to morphological words. Furthermore, the related fact that the tensed verb in compound tenses contains an auxiliary root is the consequence of the requirement that T be attached to a verbal head. In simple tenses, this requirement is satisfied by movement of the verb to T, and in compound tenses, by inserting an auxiliary verb root.

Ortiz de Urbina (1989), who defends the alternative analysis, accounts for these facts as follows. He proposes that head movement can result in two different configurations: 'amalgamation' and adjunction. In the case of movement of the verb to T, he represents these two configurations as follows:<sup>34</sup>

(69) *Head movement in Ortiz de Urbina 1989*

a. *Amalgamation*

V/T

b. *Adjunction*



He claims that this is the difference between the two types of tenses. Even though both involve movement of the verb to V, in simple tenses this movement results in amalgamation, and in compound tenses, in adjunction. Furthermore, he proposes that the requirement that T be attached to a verbal head can only be satisfied via amalgamation. Since, by hypothesis, in compound tenses, the verb and T do not amalgamate, an auxiliary verb is inserted to satisfy the requirement:

<sup>34</sup>For ease of exposition, I have ignored the *v* and Asp projections in these representations. Thus, V in these examples stands for V+v+Asp. These details are irrelevant to the argument.

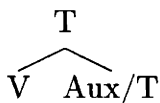
(70) *Compound tenses in Ortiz de Urbina 1995*

The question that this analysis raises is what the real difference is between amalgamation and adjunction. That is, the notational difference represented in (69) must correlate with some difference that has syntactic or morphological import: amalgamated V/T and adjoined [<sub>T</sub>V T] must be to different types of syntactic objects. For instance, one could take the notation in (69a) seriously, and propose that there are two boundary symbols, / and –, each corresponding to a different form of concatenation between heads. Thus amalgamated V and T would be V/T, and the corresponding adjunction structure would be V–T. However, this is not possible in current theories of syntax, given that boundary symbols are no longer hypothesized to be syntactically or morphologically relevant.

Another possibility would be to equate amalgamation with *fusion*, in the sense of Distributed Morphology (see Halle and Marantz 1993). In this theory, fusion is posited when two separate syntactic heads are realized by a single vocabulary item.<sup>35</sup> In this case, the two heads are joined into a single head, so that only one vocabulary item can be inserted in it. However, if the verb and T were fused in simple tenses in Basque, we would expect the resulting word to be morphologically simple. This is clearly not the case, since tensed verbs have a clear internal structure, with a distinct verbal root, a tense affix, and, as noted in footnote 1, several agreement affixes. For instance, consider the following paradigm for the verb *jun* ‘go’:

<sup>35</sup>Fusion in this theory is different from merger. When two heads are merged, they still constitute separate morphemes, as in all the examples of merger that have been proposed in this chapter. When they are fused, the resulting object is a single morpheme.

(71)		<i>jun</i> ‘go’	
		PRESENT	PAST
	1SG.ABS	n-u	n-ixu-n
	2SG.ABS	s-us	s-ixuse-n
	3SG.ABS	d-u	∅-ixu-n
	1PL.ABS	g-us	g-ixuse-n
	2PL.ABS	s-use	s-ixuse-n
	3PL.ABS	d-us	∅-ixuse-n

In this paradigm, there are two clearly defined affix positions: an absolutive agreement prefix, and a tense suffix (-*n* in the past and -∅ in the present). Although it is not clear what the analysis of the material in between should be (i.e. whether it is a single V morpheme or whether it is decomposable further), one cannot claim that tensed verbs like these have no internal structure. Therefore, amalgamation cannot be fusion.

Thus, it is not clear what ‘amalgamation’ is, or whether it is in fact different from fusion. Since the analysis defended here does not need to posit a difference between amalgamation and adjunction, it is to be preferred, unless of course, some independent evidence is given in its favor. The authors cited above do provide several arguments in favor of the alternative analysis. These are summarized in A. Elordieta 2001 (§5.2.2).

A. Elordieta (2001, p. 181), citing Hualde, Elordieta, and Elordieta 1994, briefly notes that, in the pitch accent dialects of Basque (such as Ondarroa Basque, cf. §2), the verb and auxiliary behave as a single word with respect to stress. This can be illustrated with the following examples from Ondarroa Basque:

- (72) a.  $\overline{\text{Ne}}\underline{\text{u}}$   $\underline{\text{e}}\overline{\text{torr+i}}$   $\underline{\text{na}}$   
 I.A come+PRF Aux.PR  
*I have come.*
- b.  $\overline{\text{Ne}}\underline{\text{u}}$   $\underline{\text{e}}\overline{\text{torr+ten}}$   $\underline{\text{na}}$   
 I.A come+IMP Aux.PR  
*I come.*

Recall from §2 that a stress domain is delimited by an initial rise in pitch (i.e. a left parenthesis) and a final drop in pitch (i.e. a right parenthesis). In the examples in

(72), there are two such domains: the subject *neu* (which does not have an initial rise because it does not have enough syllables, cf. §2), and the compound tense verb *etorri/etorten na*. The question is whether the stress domain formed by the verbal complex is a phrase or a word. This question is not easy to answer, since, in both cases, stress is penultimate, i.e. the drop in pitch begins on the penultimate syllable. However, in (72a), surprisingly, stress is on the final syllable. As we saw in §2 (Appendix B), final stress is possible at the phrasal level when the final vowel is deleted. Thus, final stress in (72a) can be accounted for if we posit an underlying final vowel in the auxiliary *na* which is later deleted.<sup>36</sup> This means that, with respect to the stress rules proposed in §2, the participle and auxiliary form a phrase.

But now consider example (72b). In this case, stress is penultimate, not final, even though the same auxiliary is used. As also shown in §2, vowel deletion does *not* result in final stress, but in penultimate stress, at the word level, i.e. vowel deletion does not affect the position of word level stress. This must mean that *etorten na* in (72b) is an accented *word*.<sup>37</sup> All these facts suggest that the participle and auxiliary form a single word, and that this word forms a phrase by itself.

Thus, stress facts provide a strong, albeit complex, argument for the status of the verbal complex in compound tenses as a word.<sup>38</sup> However, this argument shows that the verbal complex is a *phonological*, not necessarily morphological or syntactic, word. The facts are perfectly compatible with an analysis, such as the one defended here,

<sup>36</sup>Hualde (1996) presents further evidence for the existence of this empty vowel in this auxiliary (and others). In Ondarroa Basque, as in other dialects, there is a rule that raises *a* to *e* in the context [+high]C<sub>0</sub>\_. In this dialect, this rule must meet one further condition: *a* must be in word final position. As exemplified in (72a), the vowel *a* in the auxiliary is not raised, even though it is in final position. Furthermore, the specific syntactic environment where *na* is in this example does not, in general, block this rule, as witnessed by the fact that the vowel in the auxiliary *da* (which is the same as *na* except that it is inflected for third person absolutive agreement) does undergo the rule in this environment. Positing an underlying vowel in *na* (but not *da*) accounts for this fact too.

<sup>37</sup>Since the only difference between (72a) and (72b) is in the aspectual suffix, perfective *-i* in the former and imperfective *-ten* in the latter, this also means that *-ten* is a marked suffix and *-i* is not.

<sup>38</sup>In other pitch accent dialects where stress and other rules are different from Ondarroa Basque, the participle and auxiliary also form a single word with respect to stress. For instance, in Lekeitio Basque there is no vowel deletion rule in the context described above, and phrase level stress is final (in contrast to penultimate in Ondarroa). As shown in Hualde, Elordieta, and Elordieta 1994, the participle and auxiliary also behave as a single word with respect to stress, even though the surface facts are different from Ondarroa Basque. This strongly suggests that the hypothesis is correct, since it accounts for facts that, on the surface, look different.

in which the participle and auxiliary are separate words in the syntax, but which are joined into a single word at PF.

A similar argument for the alternative analysis is presented in G. Elordieta 1997b. Like the one discussed above, it shows that the participle and auxiliary form a single phonological word. In the dialect of Lekeitio,<sup>39</sup> a vowel optionally assimilates in all features to an immediately preceding vowel in hiatus contexts. This rule applies only word internally, as exemplified below:<sup>40</sup>

(73) *Assimilation word-internally:*

- |                                      |  |
|--------------------------------------|--|
| a. biar → biir<br>need               | b. siesta → siista<br>nap                  |
| c. basu+ak → basuuk<br>forest+ABS.PL | d. soru+en+a → soruuna<br>crazy+SUP+ABS.SG |

(74) *No assimilation across word boundaries:*

- a. seru asula → \*seru usula  
sky blue.ABS.SG
- b. paga eraiñ → \*paga araiñ  
pay make

The only (apparent) exception to this condition is that it can apply across the participle-auxiliary boundary:

(75) *Assimilation in participle-auxiliary contexts:*

- a. ikasi eben → ikasi iben  
learn.PRF Aux.3ERG.PL.PST
- b. atrapa eban → atrapa aban  
catch.PRF Aux.3ERG.SG.PST

<sup>39</sup>Lekeitio is a town neighboring Ondarroa. The two dialects are very similar, but with important differences. It is not clear whether the assimilation rule discussed below is active in Ondarroa Basque, since the vowel that would undergo assimilation is deleted by the rule discussed in Appendix B to §2. For discussion of this rule in Ondarroa Basque, see Hualde 1991a (p. 64).

<sup>40</sup>I have ignored several details of this rule which are not necessary for the argument. See G. Elordieta 1997b (§2) and Hualde, Elordieta, and Elordieta 1994 (pp. 41–42) for details.

Vowel assimilation, then, constitutes evidence for the status of the participle and auxiliary as a single phonological word. As argued for above, this can be analyzed as the result of morphological merger.

Another argument for the alternative analysis given by all the authors cited above is the fact that the participle and the auxiliary have to be adjacent.<sup>41</sup> The following examples are adapted from A. Elordieta 2001:

- (76) a. \*Karlos etorri gaur de.  
 Karlos.A come.PRF today Aux.PR  
*Karlos came today.*
- b. Karlos etorri re gaur.  
 Karlos.A come.PRF Aux.PR today
- (77) a. \*Karlosek irakurri liburu rau.  
 Karlos.E read.PRF book.A.SG Aux.PR  
*Karlos has read the book.*
- b. Karlosek liburu irakurri rau.  
 Karlos.E book.A.SG read.PRF Aux.PR

Neither adjuncts (76) nor arguments (77) can intervene between the participle and the auxiliary. This generalization is true for all adjuncts and arguments. The question raised by these examples is why they cannot have the following structure, where the XP is the adjunct/argument intervening between the participle and the auxiliary:

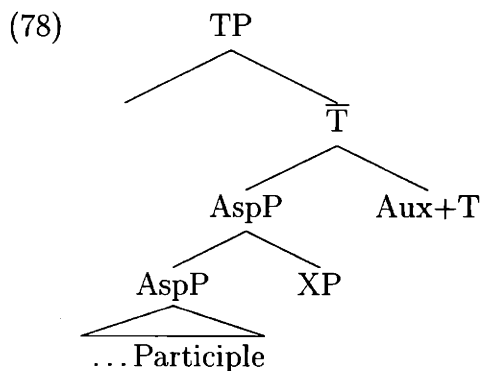

<sup>41</sup>There are two exceptions to this generalization. First, certain modal particles, such as *ete* (evidently), if present, are placed between the participle and the auxiliary. In G. Elordieta 1997b, they are analyzed as functional heads that are picked up by the verb on its way up to T, i.e. they are part of the participle-auxiliary word. Second, in negative sentences, the order participle-auxiliary is reversed, and they do not have to be adjacent. On negative sentences, see Laka 1990.

In the case of adjuncts, XP could be base generated adjoined to AspP, and in the case of arguments, it could move there from inside *v*P. If the participle and auxiliary form a single word, this generalization is accounted for. In the analysis defended here, this is a consequence of morphological merger. As argued for by Bobaljik (1996), adjuncts (or arguments moved to an adjunct position) do not block morphological merger. Thus, even if the intervening phrase in (76–77) were in the place shown in (78), the ungrammaticality of (76a–77a) is accounted for in the present analysis.

To summarize, the present analysis accounts for two kinds of facts. First, the participle and auxiliary are separate morphological words because they do not form a single complex head in the syntax. Second, in terms of word order and phonological domains, they form a single word due to morphological merger. The alternative account can explain the phonological and word order facts, but is either not explicit or unclear about the morphological fact. Thus, given the evidence presented so far, the analysis defended here provides a better account of the syntax, morphology and phonology of compound tense verbs.<sup>42</sup> The analysis defended here, in which the participle and auxiliary form two separate words in the syntax, provides a better account of all the relevant facts.

To conclude this section, A. Elordieta 2001 proposes that phrases appearing to the right of the verbal complex are not moved to the right. Rather, they are the result of movement of the verbal complex to the left. As shown above, this implies that (i) a different version of the NSR than the one defended in this thesis is needed for Basque, and (ii) the verbal complex forms a single complex head in the syntax. In this section, I have provided arguments against both proposals. This lends support

---

<sup>42</sup>There are two more pieces of data provided by the authors mentioned above in favor of the alternative analysis. First, they argue that it accounts for the fact that the auxiliary cannot appear in the first position in the sentence. This fact is accounted for by morphological merger in the analysis defended here. Since the participle and the auxiliary must merge, the participle always appears to the left of the auxiliary. The other argument, provided by G. Elordieta (1997b), is highly theory internal. Since he assumes Kayne's (1994) LCA, the only way in which the participle can appear to the left of the auxiliary is by moving the former to the left of the latter. At several points in this thesis, I provide evidence that the LCA does not hold in Basque. First, the LCA is incompatible with the Nuclear Stress Rule proposed in §3, which, as I show in the present chapter, provides a satisfactory account of sentence stress in Basque. Second, §5.10 presents evidence from reconstruction that there is rightward movement in Basque.

to the analysis proposed in this chapter, in which phrases appearing to the right of the verb are right dislocated. Further arguments that this is the correct analysis are given in §5.10.

#### 4.7 The Domain of Application of the NSR

In this chapter, I have argued that a structure sensitive NSR accounts for the placement of sentence stress in Ondarroa Basque. On the other hand, in §2, I showed that Ondarroa Basque has certain phrase level rules which are not structure sensitive. This was exemplified in (16) above, repeated below as (79).

- (79) a. [[ nire aman            ] lagune        ]    ni|re aman lagu|ne  
           my mother.G.SG friend.A.SG  
           *my mother's friend*
- b. [ nire [ lagun andixe    ] ]    ni|re lagun andi|xe  
           my friend big.A.SG  
           *my great friend*

Although these two DPs have clearly different structures, their stress pattern is exactly the same: there is a single stressed syllable (realized as a drop in pitch starting on that syllable), i.e. the penultimate one. Applying the NSR in these cases would clearly yield the wrong results. Since all the words in these DPs are unaccented (i.e. unstressed at the word level), the NSR would in fact have nothing to say about them.

These facts raise two questions. First, are these two analyses compatible? If they are, it would mean that the rules proposed in §2 apply in some phrases, and the NSR in others. If this is the case, what exactly are the types of phrases that each set of rules applies to, and is there a principled way of distinguishing them? In this section, I address these questions, arguing that both sets of rules are needed: the NSR applies to DPs and to the verbal complex as if they had no internal structure (i.e. it treats them as if they were English words); and stress within these phrases is determined by

the rules proposed in §2.<sup>43</sup> This particular answer to these questions gives DPs and the verbal complex a special status. Although I cannot give a satisfactory answer to this question, some suggestions are made at the end of this section.

First, we need to see whether all the facts can be accounted for in a unified way. As we saw above, the facts accounted for by the rules in §2 cannot be accounted for by the NSR. Thus, it would be interesting to see whether the facts about sentence stress reviewed in this chapter can be accounted for by the rules proposed in §2. The answer in this case is also a negative one. The rules in §2 assign stress to the penultimate syllable in the phrase, and to all accented words in the phrase. If there is more than one stressed syllable, the leftmost one is the most prominent one. Sentence stress in Ondarroa Basque does not work like this. For instance, in the following example (and in many others discussed in this chapter), sentence stress is not on the first stressed syllable:

- (80) Mirének **Jón** ikusí rau.  
 Miren.E Jon.A see.PRF Aux.PR  
*Miren has seen Jon.*

Therefore, we need both sets of rules. It seems that the generalization governing their application is the following one:

- (81) The internal structure of DP and the verbal complex is invisible to the NSR.  
 Stress inside these phrases is determined by the rules in §2.

The basic idea is that DPs and verbal complexes in Basque are treated by the NSR like words are in English. Their internal structure is irrelevant.

Before we illustrate this generalization, I would like to clarify what is meant by DP. In Basque, the structure of DP is [NP D Case]. The case morpheme is always suffixed to D, and when D is not overt, it is suffixed to the last word in NP.<sup>44</sup> In some cases, such as the definite determiner *-a*, D itself is a suffix:

<sup>43</sup>That the verbal complex forms a phrase by itself within which the rules in §2 apply was shown in 4.6.2 above.

<sup>44</sup>Some determiners, such as numerals 'three' and above, appear to the left of NP. In this case, the case morpheme is suffixed to the last word in NP.

- (82) a. gixon +a +k (→ gixonak)  
 man +DET +ERG  
*the man (ergative)*
- b. lagun bat +ri (→ lagun batei)  
 friend a +DAT  
*to a friend*

I assume that DPs have the following structure, where K is the case morpheme:

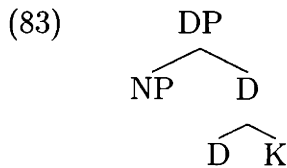

All phrases that would be translated into English as PPs also have this structure. In some cases, the English preposition is realized as a case suffix in Basque:

- (84) a. gixon +a +ntzako (→ gixonantzako)  
 man +DET.SG +BEN  
*for the man*
- b. lagun bat +gas (→ lagun bateas)  
 friend a +COM  
*with a friend*

In others, English prepositions are translated as nouns. More specifically, the phrase contains a noun with basically the same semantics as the English preposition. This noun is inflected for some case (e.g. *inesive*), and what corresponds to the English DP is realized as a DP inflected for genitive case.<sup>45</sup>

- (85) mai bat +n gain +an (→ mai baten gañin)  
 table a +GEN top +IN  
*on a table*

In sum, the term 'DP' in generalization (81) refers to more types of phrases than it might seem at first.<sup>46</sup>

Let us then illustrate generalization (81) with a sentence containing a complex DP:

<sup>45</sup>This is similar to English 'complex prepositions', such as *on top of*.

<sup>46</sup>In fact, this term also applies to non-verbal predicates. As argued for in Artiagoitia 1997 these are also DPs.

- (86) **Jonen lagún bat aia ra.**  
 Jon.G friend a.A arrive.PRF Aux.PR  
*A friend of Jon's has arrived.*

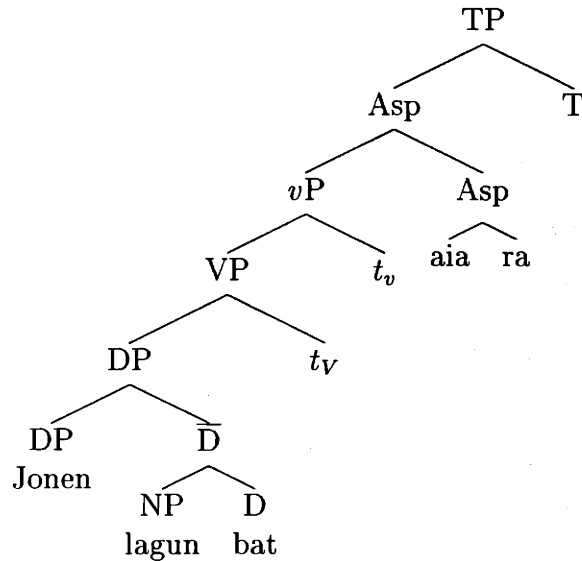

Inside DP and the verbal complex, the rules in §2 generate the following grids:

- (87)
- |                 |        |        |        |
|-----------------|--------|--------|--------|
| *               | line 2 | *      | line 2 |
| *)              | line 1 | *)     | line 1 |
| *( * * ) *      | line 0 | *(*) * | line 0 |
| Jonen lagun bat |        | aia ra |        |

Then, the NSR is used to determine sentence stress:

- (88)
- |  |          |
|--|----------|
| *_____)  | line 6   |
| *_____)  | line 5   |
| *_____*)                                       | line 4   |
| *_____)  | * line 3 |
| *_____)  | * line 2 |
| [[[[[Jonen lagun bat] $t_V$ ] $t_v$ ] aia ra]] |          |

To sum up so far, there are certain parts of the structure in Ondarroa Basque within which the NSR does not apply. In these structures, certain language particular rules (those in §2) are used to determine the placement of stress. In English, a similar condition on the application of the NSR is needed, since the internal structure of words is invisible, that is, inside words, the NSR does not determine stress placement, but a set of language particular rules (e.g. those in Halle 1998). This means that the NSR, although universal, is subject to parametric variation in terms of which domains it applies to:

(89) *The NSR and Parametric Variation*

The NSR does not apply below domain D, where the choice of D is language particular.

In English, D is the word, and in Ondarroa Basque, D is DP and the verbal complex.

This condition is given further support by languages in which the choice of D is different from both English and Ondarroa Basque. In Spanish, as argued for by Zubizarreta (1998), stress in phrases is determined by a structure dependent NSR.<sup>47</sup> Unlike in English, however, Spanish compounds are not subject to the NSR. Their internal structure is irrelevant for the placement of stress in them, as can be seen in the following examples:

- (90) a. tela + araña → telaráña  
           cloth spider spider-web
- b. hijo + puta → hijopúta  
           son whore son of a whore
- (91) a. para + aguas → paráguas  
           stop waters umbrella
- b. come + mierda → comemiérda  
           eat shit idiot

There is a fundamental difference between stress in these compounds and the corresponding phrases:

- (92) a. <sup>1</sup>tela de <sup>2</sup>arañas  
           cloth of spiders  
           *cloth made of spiders*
- b. <sup>1</sup>hijo de <sup>2</sup>puta  
           son of whore  
           *son of a whore*
- (93) a. <sup>1</sup>Para <sup>2</sup>aguas.  
           stops waters  
           *She stops waters.*

<sup>47</sup>Her version of the NSR is different from the one defended here. However, they both make the same basic predictions for Spanish phrases.

- b. <sup>1</sup> Come <sup>2</sup> miérda.  
 eats shit  
*He eats shit.*

The phrases in (92–93) contain two word level stresses (one in each word, ignoring prepositions, which never bear stress in Spanish). However, the compounds in (90–91) only have one word level stress. The NSR can account for the stress pattern in the phrases,<sup>48</sup> but not in the compounds. In fact, the stress pattern of compounds is the expected one given word level stress rules in this language (see, among others, Harris 1995, Roca 1997 and Arregi and Oltra-Massuet 2001).

This means that the domain of application of the NSR is different in the three languages. In English, the internal structure of words is invisible to the NSR (but not that of compounds); in Spanish, the structure below compounds is invisible; and in Ondarroa Basque, the structure below DP and the verbal complex is ignored by the NSR.

An important question raised by the Basque data is why both DP and the verbal complex have a special status. Unfortunately, I cannot give a satisfactory answer to this question. I would simply like to note that this is possibly related to the fact that both DPs and verbal complexes are islands to movement. As we have seen at several points in this chapter, the two units forming the verbal complex cannot be separated. This basically means that the verbal complex is an island to movement. That DPs are islands in Basque is illustrated in the following:

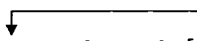
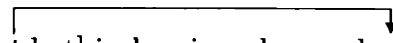
- (94) a.  \*Jonen Mirenek [<sup>t</sup> lagun bat] ikusi rau  
 Jon.G Miren.E friend a.A see.PRF Aux.PR  
*Jon, Miren has seen a friend of.*
- b.  \*[Liburo <sup>t</sup> bat] irakurri neban barri.  
 book a.A read.PRF Aux.PST new  
*I read a new book.*

<sup>48</sup>Specifically, all these phrases have a head-complement structure, and the complement is more prominent than the head.

As shown in these examples, neither left or right dislocation from DPs is possible in Basque. On the other hand, as shown by all the examples of left and right dislocation discussed in §4.5, the phrases in which the NSR does apply (e.g. VP, *v*P, AspP, etc.) are not islands to movement.

It is tempting to relate the fact that DPs are islands and that their structure is invisible to the NSR. In both cases, the internal structure is inaccessible to some operation. However, much more research is needed in this area. I leave this as a question for future work.

#### 4.8 Sentence Stress and Depth of Embedding

In §3, we discussed Cinque's (1993) version of the NSR. This theory basically predicts that sentence stress is on the most deeply embedded constituent in the sentence. On the other hand, the version of the NSR defended in this thesis adopts H&V's SEC, which, in effect, eliminates any influence that depth of embedding might have on the placement of primary stress in phrases. In fact, as we saw in §3, Cinque also needs some addition to the analysis, since depth of embedding in some crucial cases is clearly not relevant for sentence stress.

Somewhat surprisingly, all the Basque data discussed in this chapter are, in fact, compatible with the generalization that sentence stress is on the most deeply embedded constituent in the sentence. Consider, for instance, (86), repeated here as (95):

- (95) **Jonen lagún bat aia ra.**  
 Jon.G friend a.A arrive.PRF Aux.PR  
*A friend of Jon's has arrived.*



constituent. However, since the internal structure of DPs is irrelevant, any constituent inside the subject DP is ignored. For the purposes of the NSR, the subject counts as a single unit. Taking this into account, the most deeply embedded constituent accessible to the NSR is the object *Jon*, which, in fact, has sentence stress.

Even though the Basque data discussed so far are compatible with the generalization about depth of embedding, the English evidence presented in §3 is sufficient to reject it. However, it would be interesting to see whether there is any evidence from Basque bearing on this. The following is a relevant example:

- (97) [Jon jun dala] Mirének *t* pentzaten dau.  
 Jon go.PRF Aux.PR.COMP Miren.E think.IMP Aux.PR  
*That Jon has left, Miren thinks.*

What is crucial about this example is that one of the arguments is a clause. Unlike DPs, the internal structure of clauses is visible to the NSR. As shown below, *Jon*, the object of the embedded clause, is the most deeply embedded constituent in the matrix sentence:

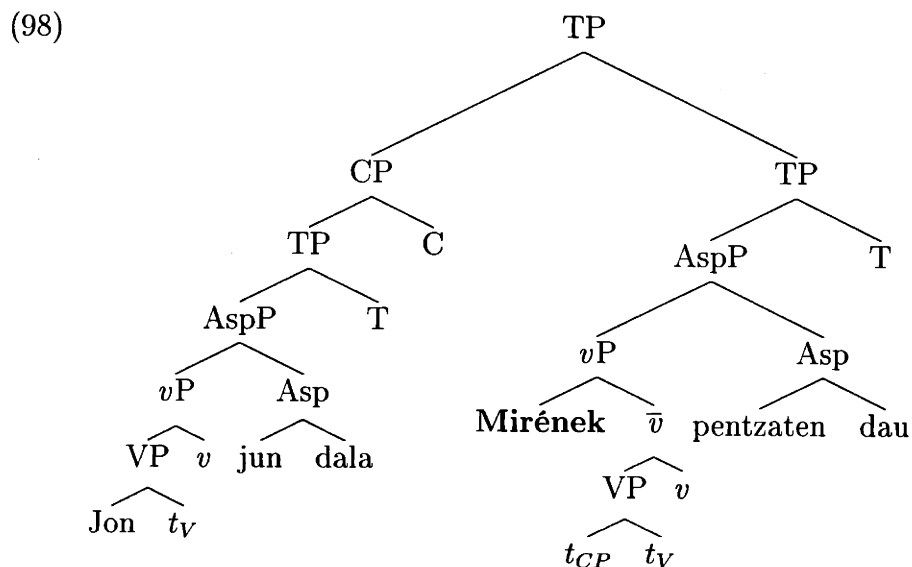

However, it is not the constituent with sentence stress. Since the internal structure of clauses is accessible to the NSR, this is a clear case in which the most deeply embedded constituent is not the one with sentence stress. In the version of the NSR adopted here, the correct prediction is made. The embedded clause is adjoined to TP.

Since it is the sister of a branching head (TP), the latter is more prominent than the former. The result, as desired, is that sentence stress is on the subject of the matrix clause, *Mirenek*.

To conclude, depth of embedding is not relevant in the computation of sentence stress. Although many Basque sentences are compatible with the generalization that sentence stress is on the most deeply embedded constituent, there are certain crucial cases that show that this generalization is wrong. This lends further support to the version of the NSR proposed in this thesis.

#### 4.9 Conclusion

In this chapter, I have provided further evidence for the NSR proposed in this thesis, by arguing that it makes correct predictions about the placement of sentence stress in Ondarroa Basque. The predictions of the analysis have been further confirmed by the interaction of the NSR and left and right dislocation in Basque. A crucial hypothesis of the present analysis is that phrases appearing to the right of the verbal complex are right dislocated. As we saw in §4.6, this hypothesis allows us to maintain the same NSR for both English and Basque. If phrases appearing to the right of the verbal complex were analyzed in different terms (i.e. leftward movement of the verbal complex), we would be forced to adopt a language-particular version of the NSR based on linear order. As we saw in that section, this version of the NSR would simply describe the facts. In the version proposed here, the facts are explained in terms of independently motivated properties of Basque syntax.

I have also argued that certain properties of the accentual system of Ondarroa Basque motivate a principle which states that certain parts of the structure are invisible to the NSR. Furthermore, I have also argued that this restriction does not hold only for Basque. Both English and Spanish have similar restrictions. What varies from language to language is the specific part of the structure within which the NSR does not apply.



## Chapter 5

### Basque Movements and Focus

#### 5.1 Introduction

One of the most studied properties of Basque syntax is its preverbal focus position.<sup>1</sup> In this language, a *wh* or focused phrase (*wh/f*-phrase) must be left-adjacent to the verbal complex. This is exemplified in the question-answer pair in (1). In the question, the *wh*-subject is left-adjacent to the verbal complex, as a result of left dislocation of the object (cf. §4.5); in the answer, the focused subject, which constitutes the ‘answer’ to the question, is also left-adjacent to the verbal complex as a result of left dislocation of the object.<sup>2</sup>

- (1) Q: Jon se $\tilde{n}$ ek t ikusi rau?  
Jon.A who.E see.PRF Aux.PR  
*Who saw Jon?*
- A: Jon Mirenek t ikusi rau.  
Jon.A Miren.E see.PRF Aux.PR  
*MIREN saw Jon.*

Similarly, in (2), the subject *wh/f*-phrase is left-adjacent to the verbal complex as a result of right dislocation of the object:

---

<sup>1</sup>This condition on word order in Basque was first described by Altube (1929). In Basque grammatical tradition, this position is termed *galdegaia*, which, curiously enough, means ‘the topic of the question, what the question is about’ (from *galde* ‘ask’ and *gai* ‘topic’).

<sup>2</sup>In all the examples below, capitals are used in the English translations to mark the focused constituent.

- (2) Q: **Señek** *t* ikusi rau Jon?  
 who.E see.PRF Aux.PR Jon.A  
*Who saw Jon?*
- A: **Mirenek** *t* ikusi rau Jon.  
 Miren.E see.PRF Aux.PR Jon.A  
*MIREN saw Jon.*

If there is no left or right dislocation of the object, the result is ungrammatical, or in the case of the focused subject, it does not have the relevant interpretation:

- (3) Q: \***Señek** Jon ikusi rau?  
 who.E Jon.A see.PRF Aux.PR  
*Who saw Jon?*
- A: #**Mirenek** Jon ikusi rau.  
 Miren.E Jon.A see.PRF Aux.PR  
*Miren saw Jon.*

In this chapter, I argue that this condition is derived from a principle that requires that a *wh/f*-phrase contain sentence stress. As argued for in §4, the NSR predicts that sentence stress in Basque is assigned to the constituent immediately preceding the verbal complex. In (1-2), this condition is satisfied by moving the object from its preverbal position. In (3), this condition is not satisfied, resulting in ungrammaticality. This analysis follows recent works on the syntax of focus in several languages, including Vallduví's (1992, 1995) work on Catalan, Zubizarreta's (1998) work on the syntax of focus in Romance and Germanic languages, and on the treatment of focus and scrambling in Dutch found in Reinhart 1995 and Neeleman and Reinhart 1998. Several recent works have provided further evidence for this approach from a variety of languages. These include Costa 1998 for Portuguese, Ishihara 2001 for Japanese, and Szendrői 2001 for Hungarian.

An analysis of Basque focus along these lines was first suggested in Arregi 2000, and further developed in Arregi 2001b. The analysis presented in this chapter provides a more detailed analysis, and is based on the new version of the NSR introduced in previous chapters. In independent work, Elordieta (2001) makes very similar proposals to the ones made here. However, there are important differences between the two

analyses. Some of these were already discussed in §4.6. Further differences between the two analyses are discussed in §§5.6–5.7, 5.9 and §5.10 below.

This chapter is organized as follows. In §5.2, I lay out some basic assumptions about the semantics of focus which will be useful in the discussion and analysis of the data presented in later sections. After reviewing the basic facts to be accounted for in §5.3, in §5.4 I provide an analysis of the facts within the framework sketched above. In §5.5, I discuss certain data having to do with focused constituents within DPs which justify a small change to the analysis presented in the previous section. §5.6 outlines the basic features that distinguish the account proposed here from those found in Ortiz de Urbina 1989, 1994, 1995 and Elordieta 2001. In §5.7, I argue that the analysis defended here provides a better account for certain focus projection facts. §5.8 examines more focus projection facts which suggests that left and right dislocation in Basque are constrained by an economy condition which basically states that they can only occur if they have an effect on the focus interpretation of the sentence. In this section, I argue that this economy condition is unnecessary, and in some cases even incorrect. The basic argument is that all the facts can be explained once we take into consideration other effects that left and right dislocation have on the discourse properties of the sentence. Finally, §5.9 discusses certain data that Ortiz de Urbina provides in favor of his analysis. In that section, I show that the data is in fact compatible with the analysis defended in this thesis.

## 5.2 The Semantics of Focus

For the purposes of this thesis, I assume Rooth's (1985, 1996) alternative semantics theory of focus. One of the basic properties of a focused element in a sentence is that it correlates with the *wh*-element in the question that the sentence is an answer to.<sup>3</sup>

- (4) a. Who wants coffee?  
       b. Ede<sub>F</sub> wants coffee.

---

<sup>3</sup>In the answers, the subscript *F* simply indicates which constituent is focused, abstracting away from the phonetic realization of focus. As is well known, focus in English is realized phonetically as a H\*L pitch accent on the syllable with primary stress within the focused constituent.

- (5) a. What does Ede want?  
 b. Ede wants coffee<sub>F</sub>.

(4b) is a felicitous answer to the question in (4a), but not to (5a). Similarly, (5b) is a possible answer to (5a), but not to (4a).

I assume, following Jackendoff 1972, that focus is marked by a feature F in the focused phrase. In the theory of alternative semantics, a sentence  $\phi$  containing an F-marked constituent has two different semantic values: its ordinary semantic value,  $\llbracket \phi \rrbracket^o$  (a proposition), and an additional semantic value,  $\llbracket \phi \rrbracket^f$ , which is a set of propositions obtained by making substitutions in the position of the focused phrase. Thus, the focus value of *Ede<sub>F</sub> wants coffee* is the set of propositions of the form *x wants coffee*, and the focus value of *Ede wants coffee<sub>F</sub>* is a set of propositions of the form *Ede wants y*. The basic function of focus, then, is to introduce alternatives to the proposition denoted by the sentence.

In this theory, the question-answer paradigm in (4–5) is explained as follows. First, following Hamblin 1973, the ordinary semantic value of a *wh*-question is a set of propositions which are obtained by making substitutions in the position of the *wh*-constituent. That is, a question denotes the set of all possible answers to it. For instance, the question *Who wants coffee?* denotes the set of propositions of the form *x wants coffee*, and the question *What does Ede want?* denotes the set of propositions of the form *Ede wants y*. A question-answer pair must meet the condition that the set denoted by the question be consistent with the set denoted by the focus value of the answer.<sup>4</sup> Thus, (4b) is a possible answer to (4a) because both characterize the same set of propositions (i.e. those of the form *x wants coffee*). On the other hand, (4b) is not a possible answer to (5a) because the latter denotes the set *Ede wants x*.

---

<sup>4</sup>Specifically, where  $\phi$  is an answer to a question, the set denoted by the question must be a subset of  $\llbracket \phi \rrbracket^f$  containing  $\llbracket \phi \rrbracket^o$  and at least one more element.

### 5.3 The Preverbal Position in Basque

The preverbal position was exemplified in (1–3), repeated below as (6–8), with a subject *wh/f*-phrase:

- (6) Q: Jon **señek** ikusi rau?  
 Jon.A who.E see.PRF Aux.PR  
*Who saw Jon?*
- A: Jon **Mirének** ikusi rau.  
 Jon.A Miren.E see.PRF Aux.PR  
*MIREN saw Jon.*
- (7) Q: **Señek** ikusi rau Jon?  
 who.E see.PRF Aux.PR Jon.A
- A: **Mirének** ikusi rau Jon.  
 Miren.E see.PRF Aux.PR Jon.A
- (8) Q: \***Señek** Jon ikusi rau?  
 who.E Jon.A see.PRF Aux.PR
- A: #**Mirének** Jon ikusi rau.  
 Miren.E Jon.A see.PRF Aux.PR

In the question, the subject is a *wh*-phrase and therefore has to be left-adjacent to the verbal complex. In the answer to the question, the subject must accordingly be interpreted as focused. This is possible only when the subject is immediately preceding the verbal complex (cf. 6–7). If it is further to the left (cf. 8), the result is not a proper answer to the question. The same infelicitous result is obtained if the subject is to the right of the verb:

- (9) Q: \*Jon ikusi rau **señek**?  
 Jon.A see.PRF Aux.PR who.E
- A: #Jon ikusi rau **Mirének**.  
 Jon.A see.PRF Aux.PR Miren.E

In the case of object *wh/f*-phrases, the same condition holds: the object has to be left-adjacent to the verb.

- (10) Q: Mirenek **séin** ikusi rau?  
 Miren.E who.A see.PRF Aux.PR  
*Who has Miren seen?*

A: Mirenek **Jón** ikusi rau.  
 Miren.E Jon.A see.PRF Aux.PR  
*Miren has seen JON.*

(11) Q: **Séin** ikusi rau Mirenek?  
 who.A see.PRF Aux.PR Miren.E

A: **Jón** ikusi rau Mirenek.  
 Jon.A see.PRF Aux.PR Miren.E

(12) Q: \***Séin** Mirenek ikusi rau?  
 who.A Miren.E see.PRF Aux.PR

A: #**Jón** Mirenek ikusi rau.  
 Jon.A Miren.E see.PRF Aux.PR

(13) Q: \*Mirenek ikusi rau **séin**?  
 Miren.E see.PRF Aux.PR who.A

A: #Mirenek ikusi rau **Jón**.  
 Miren.E see.PRF Aux.PR Jon.A

Similarly, the subject of intransitive sentences must also be left-adjacent to the verbal complex when it is a *wh/f*-phrase:

(14) Q: **Séin** aia san atzo?  
 who.A arrive.PRF Aux.PST yesterday  
*Who arrived yesterday?*

A: **Amáia** aia san atzo.  
 AmaiaA arrive.PRF Aux.PST yesterday  
*AMAIA arrived yesterday.*

(15) Q: \*Aia san **séin** atzo?  
 arrive.PRF Aux.PST who.A yesterday

A: #Aia san **Amáia** atzo.  
 arrive.PRF Aux.PST AmaiaA yesterday

(16) Q: \*Aia san atzo **séin**?  
 arrive.PRF Aux.PST yesterday who.A

A: #Aia san atzo **Amáia**.  
 arrive.PRF Aux.PST yesterday AmaiaA

(17) Q: Amen **séñek** jolasten dau?  
 here who.E play.IMP Aux.PR  
*Who plays here?*

A: Amen **Aitórrek** jolasten dau.  
 here Aitor.E play.IMP Aux.PR  
*AITOR plays here.*

(18) Q: \***Séñek** amen jolasten dau?  
 who.E here play.IMP Aux.PR

A: #**Aitórrek** amen jolasten dau.  
 Aitor.E here play.IMP Aux.PR

(19) Q: \*Amen jolasten dau **séñek** ?  
 here play.IMP Aux.PR who.E

A: #Amen jolasten dau **Aitórrek**.  
 here play.IMP Aux.PR Aitor.E

Finally, as shown in the following examples, adverbial *wh/f*-phrases are also subject to the same condition:

(20) Q: Jon **nóis** jun san?  
 Jon.A when go.PRF Aux.PST  
*When did Jon leave?*

A: Jon **átzo** jun san.  
 Jon.A yesterday go.PRF Aux.PST  
*Jon left YESTERDAY.*

(21) Q: \***Nóis** Jon jun san?  
 when Jon.A go.PRF Aux.PST

A: #**Átzo** Jon jun san.  
 yesterday Jon.A go.PRF Aux.PST

(22) Q: **Selánik** arregla sendun armaxu?  
 how fix.PRF Aux.PST closet.A.SG  
*How did you fix the closet?*

A: **Matrallúas** arregla neban armaxu.  
 hammer.COM.SG fix.PRF Aux.PST closet.A.SG  
*I fixed the closet with the HAMMER.*

(23) Q: \*Armaxu arregla sendun **selánik**?  
 closet.A fix.PRF Aux.PST how

A: #Armaxu arregla neban **matrallúas**.  
 closet.A fix.PRF Aux.PST hammer.COM.SG

To summarize, *wh*-phrases must be left-adjacent to the verbal complex. Furthermore, as shown by the question-answer congruence test, focused phrases must also be left-adjacent to the verb. In the next section, I argue that these facts are derived from certain prosodic conditions imposed on these phrases.

#### 5.4 The Preverbal Position and the NSR

In this section, I argue that the NSR is crucial in deriving the the preverbal focus position. The basic idea is that the distribution of *wh/f*-phrases is governed by the following PF condition (cf. Chomsky 1971, Jackendoff 1972, Truckenbrodt 1995, Zubizarreta 1998, Reinhart 1995):

- (24) The F-marked phrase in a sentence must contain the primary stress in that sentence.

As argued in §4, the NSR proposed in this thesis derives the fact the primary stress in a sentence is on the constituent preceding the verbal complex. Thus, condition (24), applied to Basque, means that the focused constituent must be the constituent preceding the verbal complex.

Consider sentences with focus on the object first. In a transitive sentence with a focused object, the object must be left adjacent to the verb:

- (25) a. Mirenek Jon<sub>F</sub> ikusi rau.  
 Miren.E Jon.A see.PRF Aux.PR  
*Miren has seen JON.*
- b.  $\overbrace{t \text{ Jon}_F \text{ ikusi rau}} \downarrow$  Mirenek.  
 Jon.A see.PRF Aux.PR Miren.E

In (25a), the object *Jon* is in its base position inside VP:

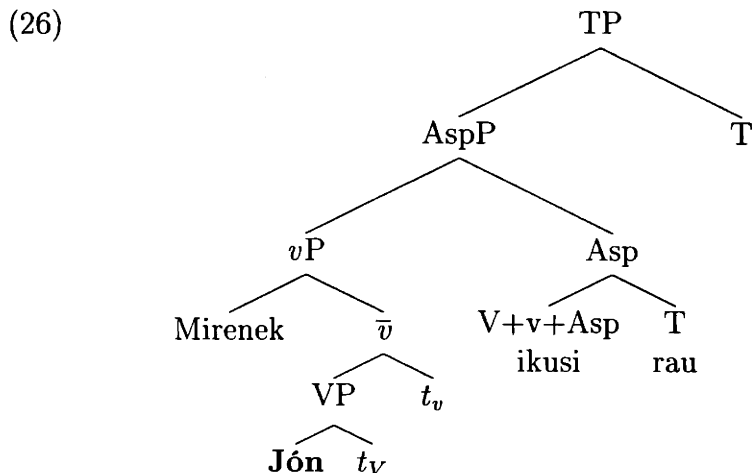

As we saw in §4, when the object is in its base position, it is assigned sentence stress by the NSR:

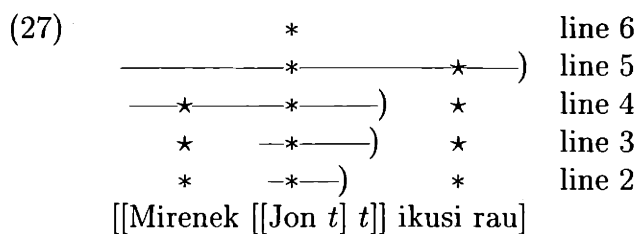

Since the object is focused and it contains sentence stress, condition (24) is satisfied. Sentence (25b) is like (25a), except that the the subject is right dislocated. Since, as shown above, the object has sentence stress when it stays in VP, condition (24) is satisfied in this case too.

The above two sentences cannot be interpreted with focus on the subject, since this constituent does not contain sentence stress. On the other hand, when the subject is immediately preceding the verbal complex, this interpretation is possible:

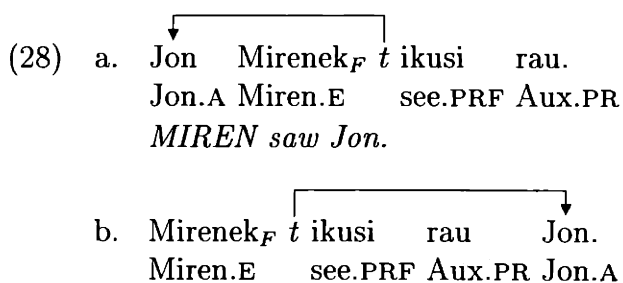

The basic idea, following, among others, Vallduví 1992, Reinhart 1995 and Zubizarreta 1998, is that movement of constituents other than XP can result in XP having sentence

stress, which allows it to be interpreted as focused. In these sentences, the object is left or right dislocated. Since both left and right dislocation result in adjunction to TP, the subject is the only overt constituent in *vP*:

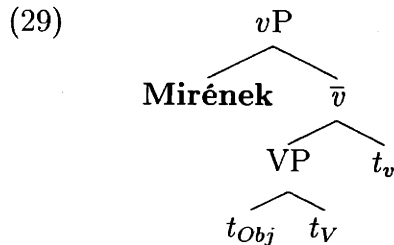

As shown in §4, the subject is assigned sentence stress in this configuration. Thus, (24) is satisfied. If, on the other hand, the object were focused in these sentences, the result would not be grammatical, since the object does not contain sentence stress.

As can be seen in the examples above, the present analysis explains why focused constituents have to be left-adjacent to the verb. In fact, the analysis imposes an even stronger condition. As we saw in §4.5.3, when both the subject and the object are moved out of *vP*, sentence stress is on the verbal complex. In this case, the sentence cannot be interpreted with focus on the preverbal constituent, since it does not contain sentence stress:

- (30) Q: Mirenek sein ikusi rau?  
 Mirenek.E who.A see.PRF Aux.PR  
*Who has Miren seen?*

A: #Mirenek Jon t t ikusi rau.  
 Mirenek.E Jon.A see.PRF Aux.PR

```

graph TD
    Root --> Mirenek["#Mirenek"]
    Root --> VP
    VP --> Jon
    VP --> t1["t"]
    t1 --> t2["t"]
    t1 --> ikusi_rau["ikusi rau"]
  
```

- (31) Q: Señek ikusi rau Jon?  
 who.E see.PRF Aux.PR Jon.A  
*Who has seen Jon?*

A: #Mirenek t t ikusi rau Jon.  
 Miren.E see.PRF Aux.RAU Jon.A

```

graph TD
    Root --> Mirenek["#Mirenek"]
    Root --> VP1
    VP1 --> t1["t"]
    VP1 --> VP2
    VP2 --> t2["t"]
    VP2 --> ikusi_rau["ikusi rau"]
    Root --> Jon
  
```

In both sentences, the subject and the object have been extracted out of *vP*. The structure of AspP after movement is as follows:

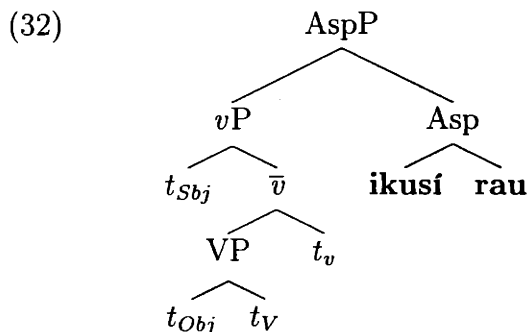

In this structure, the verbal complex is assigned sentence stress, so neither the subject nor the object can be understood as focused.<sup>5</sup>

Nothing that has been said so far predicts that *wh*-phrases are preverbal. However, as I showed in §5.3, they also must appear in the preverbal position. Following Zubizarreta 1998 (pp. 92–97, and references cited there), I assume the following principle:

- (33) *Wh*-phrases are F-marked.<sup>6</sup>

This correctly predicts that *wh*-phrases must be left-adjacent to the verb. This is confirmed by all the *wh*-question data provided in §5.3, some of which are repeated below:

- (34) a. Jon **séñek** ikusi rau?  
 Jon.A who.E see.PRF Aux.PR  
*Who has seen Jon?*
- b. \***Señek** Jon ikusi rau?  
 who.E Jon.A see.PRF Aux.PR
- (35) a. **Séin** ikusi rau Mirenek?  
 who.A see.PRF Aux.PR Miren.E  
*Who has Miren seen?*

<sup>5</sup>A number of different focus interpretations arise when sentence stress is on the verb. In the above sentences, the most salient interpretation is *verum* focus (i.e. focus on the positive polarity of the sentence). Another possibility is focus on the verb itself, which also involves certain specific morphological changes in the verbal complex. Although, I believe, the basic facts are compatible with the analysis defended here, there are certain complexities in the data that I have not been able to examine thoroughly. I leave this as a question for future research.

<sup>6</sup>This principle might seem to make wrong predictions for languages, like English, where *wh*-phrases do not necessarily have sentence stress. I follow Zubizarreta in assuming that F-marked phrases can be licensed in different ways (i.e. via prosody or via movement to [Spec,CP]) in different languages. See Zubizarreta 1998 (pp. 92–97) for discussion.

- b. \*Mirenek ikusi rau sein?  
 who.E see.PRF Aux.PR who.A

As with focused phrases, the prediction is even stronger: the *wh*-phrase has to have sentence stress. If the grammatical sentences in (34–35) are pronounced with sentence stress on the verb, the result is ungrammatical.

The analysis developed so far also accounts for all the other data discussed in §5.3. Consider, for instance, the intransitive sentence in (36):

- (36) a. Atzo **Jón** jun san.  
 yesterday Jon.A go.PRF Aux.PST  
*JON left yesterday.*
- b. Jon **átzo** t jun san.  
 Jon.A yesterday go.PRF Aux.PST  
*Jon left YESTERDAY.*

The structure of (36a) is as follows:

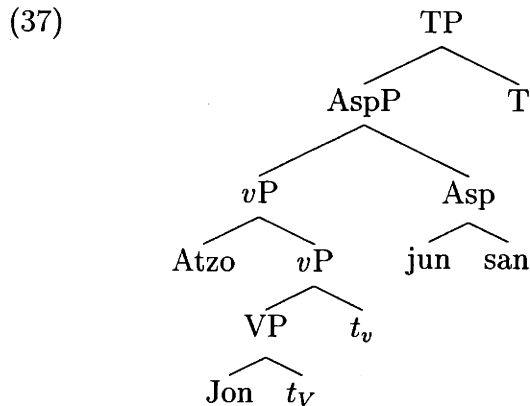

The subject *Jon* is the only overt constituent inside VP, and thus receives sentence stress. As predicted, it can be understood as focused. On the other hand, if the subject is left dislocated, as in (36b), the adverbial *atzo* receives sentence stress and can be understood as focused. Focus cannot be on the subject in this case.

### 5.5 Focus and the Domain of Application of the NSR

Principle (24), as stated above, encounters some problems when we take into account the fact that, as we saw in §4, the NSR does not apply within DPs in Ondarroa Basque. The following sentence illustrates this problem:

- (38) Aitorrek **neure áma** ikusi ban.  
 Aitor.E my mother.A see.PRF Aux.PST  
*Aitor saw my mother.*

This sentence, as predicted by the NSR, has sentence stress on the object *neure ama* ‘my mother’. As shown in Hualde et al. 1994 and Elordieta 1997a,<sup>7</sup> it can have at least three different focus readings, each corresponding to one of the following continuations:<sup>8</sup>

- (39) a. *Focus on ‘my mother’:*  
 ... es Jon.  
 not Jon.A
- b. *Focus on ‘mother’:*  
 ... es neure atxe.  
 not my father.A
- c. *Focus on ‘my’:*  
 ... es seure ama.  
 not your mother.A

However, there is only one way of pronouncing the object *neure ama*. As we saw in §4.7, the NSR does not apply within it. Its stress pattern is determined by the phrasal rules discussed in §2. Since this phrase only contains unaccented words, these rules assign stress to a single syllable within it. Specifically, stress is assigned on the penultimate syllable of the DP, i.e. on the first syllable of the noun *ama*. That means that both the object *neure ama* and the noun *ama* can be focused, according to (24), since both constituents contain sentence stress. These are the two readings in (39a-b), respectively. However, reading (39c) is wrongly predicted to be ungrammatical, since *neure* ‘my’ does not contain sentence stress.

I propose the following modification to condition (24) to account for this fact:

- (40) The minimal phrase accessible to the NSR which contains the F-marked phrase in a sentence must contain the primary stress in that sentence.

<sup>7</sup>These authors discuss the same facts in the variety spoken in the neighboring town of Lekeitio.

<sup>8</sup>In fact, it can also have other readings: focus on the object and the verbal complex, and focus on the whole sentence. These are discussed in §5.7 below.

With this modification, reading (39c) is accounted for as follows. In this reading, the genitive pronoun *neure* 'my' is F-marked. The minimal phrase containing it which is accessible to the NSR is the object *neure ama* 'my mother'. Since the object also contains sentence stress (on the first syllable of *ama*), (40) is satisfied. The other readings of this sentence are accounted for in a similar way: the minimal phrase accessible to the NSR containing *neure ama* or *ama* is the whole DP; since the whole DP also contains sentence stress, both readings are predicted to be grammatical.

The revised condition also accounts for similar facts found in sentences with simple tense verbs. As we saw in §4, sentence stress in this case is on a phrase formed by the tensed verb and the phrase preceding it:

- (41) Jonek **diru**            **rákar**.  
 Jon.E money.A.SG has  
*Jon has MONEY.*

As discussed in §4.3, this fact can be accounted for by assuming that the tensed verb and the preceding phrase (the object *diru* 'money' in this case) are joined into a single phrase by morphological merger:

- (42)
- $$\begin{array}{c}
 \text{DP} \\
 \swarrow \quad \searrow \\
 \text{DP} \quad \text{T} \\
 \wedge \quad \wedge \\
 \text{diru} \quad \text{rakar}
 \end{array}$$

The resulting DP is a constituent whose internal structure is inaccessible to the NSR. Within it, the stress rules in §2 place stress on the penultimate syllable (i.e. on the first syllable of *rakar*). Furthermore, this DP is assigned sentence stress by the NSR, since it is the only overt constituent within VP:

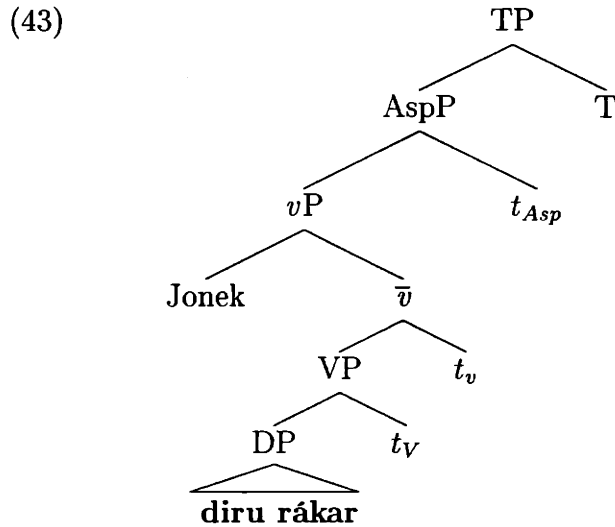

However, the sentence can be understood with focus on the object *diru* ‘money’, as witnessed by the fact that it can be an answer to *What does Jon have?*. Under the unrevised condition in (24), this reading would not be possible: sentence stress is on the verb *rákar*. Under the revised condition in (40), this reading is possible, since the minimal phrase accessible to the NSR which contains the focused object is the constituent *diru rákar*, which also contains sentence stress.

### 5.6 On Focus Movement

Most previous accounts of the preverbal focus position in Basque propose that it is a syntactically defined position. Specifically, Ortiz de Urbina (1989, 1994, 1995) proposes that *wh/f*-phrases must move to [Spec, CP]. Adjacency between the focused constituent and the verbal complex is obtained by movement of the latter to the head of CP, which in this analysis is left-headed:

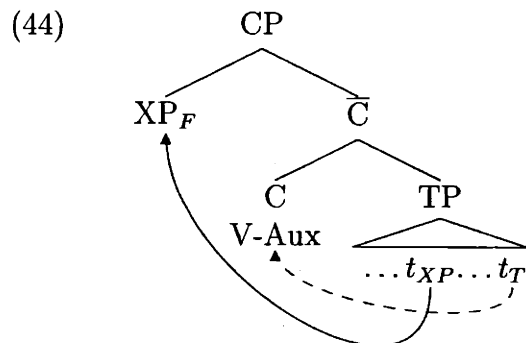

The basic idea is that the word order restriction that Basque imposes on focused (and *wh*-) phrases has the same syntactic explanation that the V2 phenomenon does in German (see Den Besten 1977).<sup>9</sup> For instance, an SVO sentence with focus on the subject has the following structure:<sup>10</sup>

- (45) **Jónek** irakurri ban ori liburu.  
 Jon.E read.PRF Aux.PST that.A book.A.SG  
*JON read that book.*

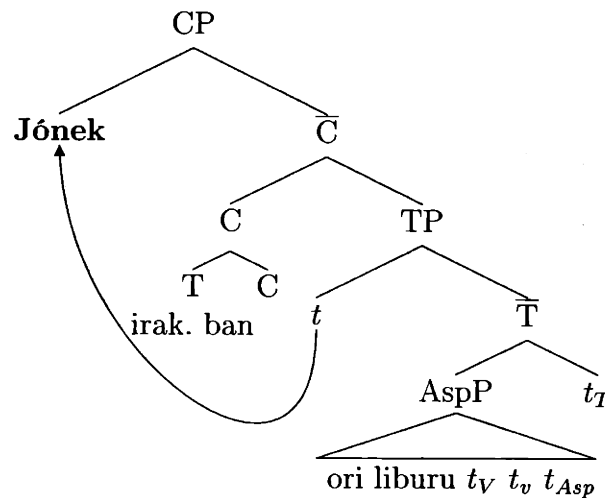

In an SOV sentence with focus on the subject, the object moves to [Spec, CP], and the subject moves further to the left:<sup>11</sup>

- (46) Jonek **ori** libúru irakurri ban.  
 Jon.E that.A book.A.SG read.PRF Aux.PST  
*Jon read THAT BOOK.*

<sup>9</sup>The particular machinery needed to derive both movements is not important for the purposes of this section. See Ortiz de Urbina 1989, 1994, 1995 for details.

<sup>10</sup>In this structure, the subject is generated [Spec, TP], which is consistent with Ortiz de Urbina's (1989) assumptions. As we saw in §4, I do not assume that the subject of a transitive sentence must move to [Spec, TP]. This detail is not relevant for the purposes of this section. See §4 for discussion.

<sup>11</sup>The movement of the subject in this sentence is basically the same as the one termed 'left dislocation' in this thesis (cf. §4 and §5.8.3 below).

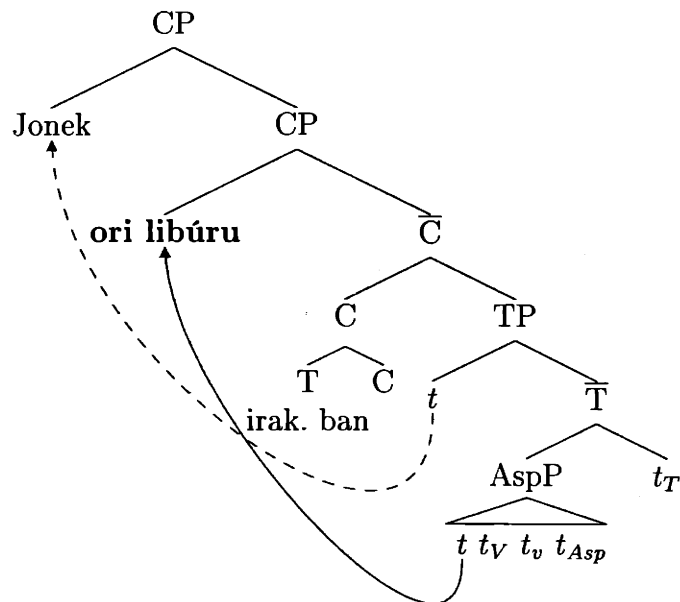

In contrast, in the analysis defended here, *wh/f*-phrases do not move (overtly) to a fixed syntactic position.<sup>12</sup> The fact that they have to be left-adjacent to the verb is seen as a consequence of the fact that they need sentence stress. In this analysis, (45) involves right dislocation of the object, and (46) involves neither right nor left dislocation:

(47) *Structure for (45)*

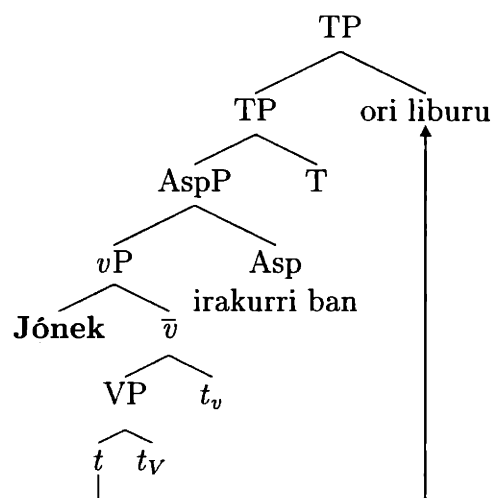

<sup>12</sup>I do not rule out that either focused or *wh*-phrases move to some fixed position covertly. None of the data presented in this thesis bears on this issue. The arguments in favor of covert movement of *in situ wh*-phrases are well known (cf. Huang 1982 and much subsequent work), although the problems with this analysis are also well known (see Reinhart 1994 and Rullmann and Beck 1998 for some recent proposals). For discussion on covert movement of focused constituents, see, among others, Chomsky 1976, Rooth 1985, Drubig 1994 and Krifka 1996.

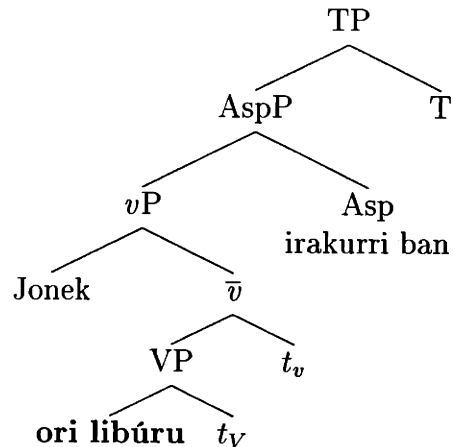
(48) *Structure for (46)*

Elordieta (2001) proposes what might be termed a “mixed” approach, which can be summarized as follows. In sentences in which there are no phrases to the right of the verb (e.g. 46), the focused constituent does not move to [Spec, CP]; it is left-adjacent to the verb because it needs sentence stress, as in the analysis defended here. In sentences in which there are one or more phrases to the right of the verb (e.g. 45), the focused constituent moves to [Spec, CP] (and the verbal complex to C), as in the analysis proposed by Ortiz de Urbina. The main motivation for this approach is that, although the placement of sentence stress and prosodic requirements on focused phrases can explain the preverbal position in some cases (e.g. 46, 48), she rejects the idea that constituents appearing to the right of the verbal complex are right dislocated (e.g. 45).<sup>13</sup> This aspect of her analysis is what makes it crucially different from the account proposed here. Her arguments against rightward movement are evaluated in §5.10, where I argue that right dislocation does exist in Basque.

In §4.6.2, we saw some arguments against a particular aspect of both Ortiz de Urbina’s (1989, 1994, 1995) and Elordieta’s (2001) analyses. Specifically, since in both the verbal complex can move to C as a unit, they need to assume that the

<sup>13</sup>Elordieta does not exclude the possibility that some phrases are base generated to the right of the verbal complex as adjuncts or specifiers to some verbal or functional projection (in fact, that is what she proposes for indirect objects appearing to the right of the verbal complex). Thus, the reason for rejecting rightward movement is not some constraint on the mapping between syntactic structure and word order (cf. Kayne’s (1994) LCA). Rather, she gives empirical arguments that some constituents are base generated as right adjuncts/specifiers, and that other phrases appearing to the right of the verbal complex have not been moved to the right. These arguments are discussed in §5.10.

participle and the auxiliary form a complex head in the syntax. As we saw there, this does not provide a satisfactory account of all the relevant phonological and morphological properties of the verbal complex. In the next section, I provide evidence from focus projection which argues that the analysis defended in this chapter provides a more principled account of the data. The argument applies to both Ortiz de Urbina's analysis and Elordieta's, although in the latter case the argument is a little more complicated because of the partial similarity between that analysis and the one proposed here.<sup>14</sup>

### 5.7 Focus Projection

As is well-known an English transitive sentence with SVO order and sentence stress on the object can have several focus readings:

(49) John drank some COFFEE.

(50) a. What did John drink?

b. What did John do?

c. What happened?

Sentence (49) can be an answer to any of the three questions in (50). As an answer to question (50a), the sentence is interpreted with focus on the object; as an answer to (50b), it is interpreted with focus on the constituent containing the verb and the object (VP); and as an answer to (50c), it is interpreted with focus on the whole clause.

Quite generally, the focused constituent can be larger than the constituent with sentence stress, as long as the latter is contained in the former. This well-known phenomenon, termed "focus projection", is expected in the framework adopted here. As shown in Chomsky 1971, it is predicted by the condition that requires that the

---

<sup>14</sup>Other analyses of the preverbal focus position include: de Rijk 1978, Azkarate et al. 1982, Ortiz de Urbina 1983, Eguskitza 1986, Laka and Uriagereka 1987, Uriagereka 1992, 1999, Albizu 1995. See Elordieta 2001 (§4.3) for discussion of most of these works. The criticisms she makes of these analyses are, for the most part, also valid from the point of view defended in this thesis.

focused constituent contain sentence stress (see also Jackendoff 1972, Cinque 1993, Zubizarreta 1998, Reinhart 1995).<sup>15</sup> In this thesis, this condition is formulated as (40), repeated below as (51).

- (51) The minimal phrase accessible to the NSR which contains the F-marked phrase in a sentence must contain the primary stress in that sentence.

In (49), the object contains sentence stress. Thus, the object, the VP or the whole sentence can be understood as focused, since all of them contain sentence stress. The reading in which the whole clause is focused is the “neutral” reading, i.e. one in which no particular subconstituent in the sentence is focused.

In the analysis of Basque focus proposed in this chapter, this phenomenon is also expected to occur in this language. This prediction is borne out, as illustrated by the fact that (52) is an appropriate answer to either question in (53):

- (52) **Jón** jun san.<sup>16</sup>  
 Jon.A go.PRF Aux.PST  
*Jon left.*
- (53) a. Sein jun san?  
 who.A go.PRF Aux.PST  
*Who left?*

<sup>15</sup>There is an alternative view of these facts, defended, among others, by Schmerling 1976, Gussenhoven 1984, Selkirk 1984, 1995 and Rochemont 1986. See Zubizarreta 1998 (§2.5.1) for discussion and criticism of this type of analysis.

<sup>16</sup>As an answer to (53b) (*What happened?*), speakers have a strong preference to add the suffix *-(e)la* to the auxiliary verb (*san+ela*). This suffix is equivalent to the English complementizer *that*. A similar phenomenon occurs in Spanish, as illustrated in the following:

- (i) Q: ¿Qué pasó?  
 Qué happened
- A: Que Juan bebió café. / #Juan bebió café.  
 that Juan drank coffee

This detail is not important for our purposes. I have accordingly omitted the suffix *-(e)la* in all examples below which are possible answers to *What happened?* In English, there is no such preference (in fact, the answer beginning with *that* is ungrammatical). The explanation of this difference between these languages might be, in part, that the answer is understood as the complement of (an elided) *happen*, and that the complementizer is obligatory in Basque and Spanish complement clauses, but optional in English.

- b. Se pasa san?  
 what.A happen.PRF Aux.PST  
*What happened?*

Sentence stress in (52) is on the subject *Jón*. As in English, the focused constituent can be either the subject *Jon* or the whole sentence, since both constituents contain sentence stress. This last reading is the “neutral” reading that was used in §4 to determine the basic facts about syntactic structure and word order in Basque.

The same point is illustrated in the following transitive sentence:

- (54) Jonek **káfi** era ban.  
 Jon.E coffee.A.SG drink.PRF Aux.PST  
*Jon drank COFFEE.*

- (55) a. Jonek se era ban?  
 Jon.E what.A drink.PRF Aux.PST  
*What did Jon drink?*

- b. Se pasa san?  
 what.A happen.PRF Aux.PST  
*What happened?*

The sentence in (54) has the following structure:

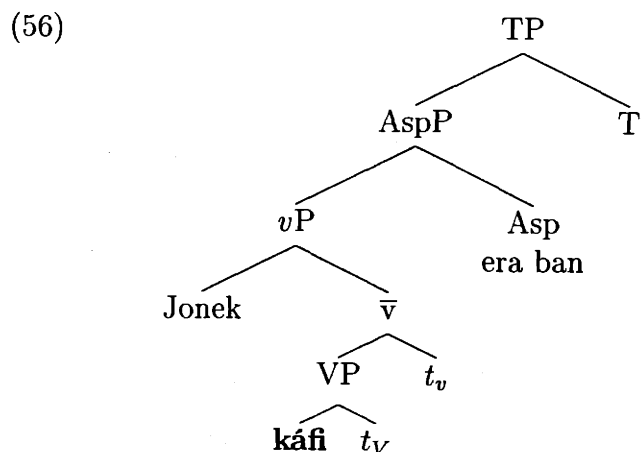

Sentence stress is on the object *káfi*. Accordingly, the sentence can be understood with focus on the object (i.e. as an answer to 55a), or with focus on the whole clause (i.e. as an answer to 55b).<sup>17</sup>

<sup>17</sup>In the structure given to (54), there is a constituent, *vP*, which contains both the subject and the object. This predicts that *vP* can also be understood as focused. This prediction is borne out; (54) can also be an answer to *Who drank what?*

(54) can also be interpreted with focus on the verb and the object, since it can also be an answer to:

- (57) Jonek se ei ban?  
 Jon.E what do.PRF Aux.PST  
*What did Jon do?*

In the structure given above, this reading is not predicted, since there is no constituent that contains both the object and the verbal complex. However, the structure given above is not the only possible one for (54). In particular, a structure in which the subject is left dislocated is also consistent with this sentence:

- (58) [TP Jonek [TP [vP t káfi ] era ban ]]  
 Jon.E coffee.A.SG drink.PRF Aux.PST

The NSR proposed in this thesis predicts that sentence stress is on the object in this sentence, whether the subject is left dislocated or not. When it is left dislocated, the reading in which the object and the verbal complex are understood as focused is possible, since there is one constituent (TP) that contains both.

To summarize, the analysis of focus in Basque proposed in this chapter accounts for the focus projection facts discussed in this section. Furthermore, it does so in the same way in which the same facts are explained in English.<sup>18</sup> This is not the case in Ortiz de Urbina's (1989, 1994, 1995) analysis, since the syntax of focus in the two languages in this framework is very different.

First, it is not clear how these facts are accounted for in an analysis like Ortiz de Urbina's, where focused constituents move to [Spec, CP]. Let us consider the transitive sentence in (54), repeated below as (59), under Ortiz de Urbina's assumptions. The structure before any movement to [Spec, CP] or C is as follows:<sup>19</sup>

<sup>18</sup>There is a small difference in the accounts of English and Basque. As discussed above, the reading in which the object and the verb are focused requires a slightly different structure in Basque. This difference, however, is independently motivated. While in English the subject always moves out of vP, this is not always the case in Basque.

<sup>19</sup>As noted in §4, Ortiz de Urbina proposes that subjects surface in [Spec, IP]. See footnote 27 on page 131 for discussion. I have also abstracted away from *v* in this structure. Neither detail is important for the purposes of this section.

- (59) Jonek **káfi** era ban.  
 Jon.E coffee.A.SG drink.PRF Aux.PST  
*Jon drank COFFEE.*

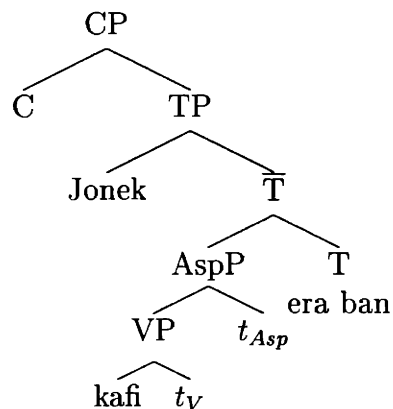

Recall that this sentence has three different focus readings: (i) focus on the object, (ii) focus on the object and the verb, and (iii) focus on the whole clause. In Ortiz de Urbina’s analysis reading (iii) does not involve any movement: this is the “neutral” reading, which can be taken to be the case in which the sentence contains no focused constituent.

Reading (i) is derived as we saw in the previous section: the focused object moves to [Spec, CP], and the verbal complex moves to C. Since the subject is to the left of the focused object, it must have moved further to the left:

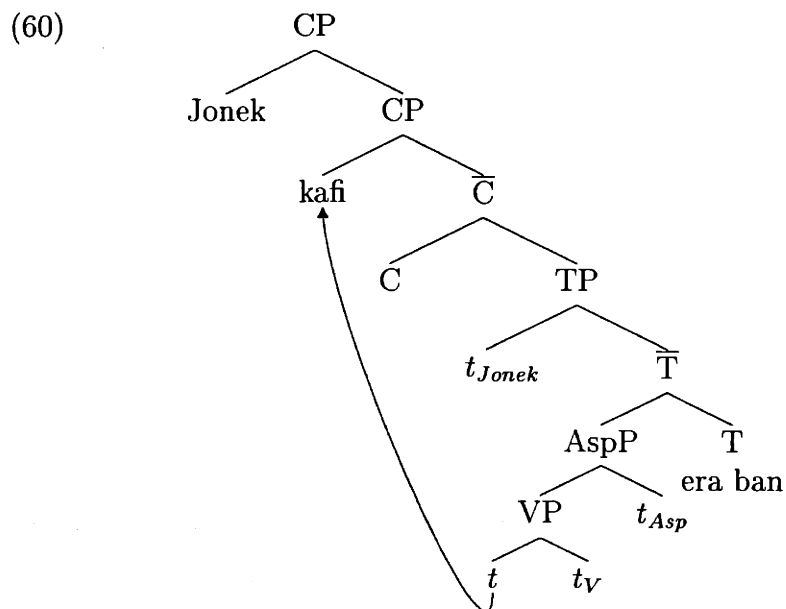

However, it is not clear how reading (ii), in which both the verb and the object are part of the focus, should be derived. The only constituent containing only both elements is  $\bar{T}$ . Moving this phrase to [Spec, CP] would yield (with further movement of the subject to the left):

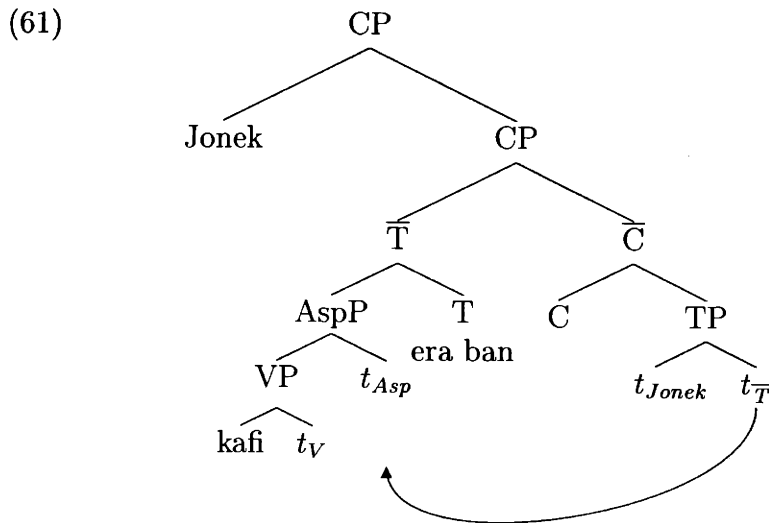

There is, however, a problem with this structure. In Ortiz de Urbina's analysis, movement of the verbal complex from T to C is obligatory.<sup>20</sup> That is how the focused constituent and the verbal complex are adjacent. Although in this structure they are adjacent, the verbal complex is not in C. This problem could be solved by assuming that T moves to C before movement of  $\bar{T}$  to [Spec, CP]:

<sup>20</sup>What exactly motivates this movement is not relevant for this point. In Ortiz de Urbina 1994, this is motivated by Rizzi's (1991) Operator Criterion: an operator feature (such as [wh] or [Foc]) must be matched by a corresponding feature on a head in a specifier-head configuration. In Basque, the [Foc] (and [wh]) head feature is in T. Movement of T to C (and of the focused constituent to [Spec, CP]) is then motivated by the need to satisfy the Operator Criterion with respect to [Foc].

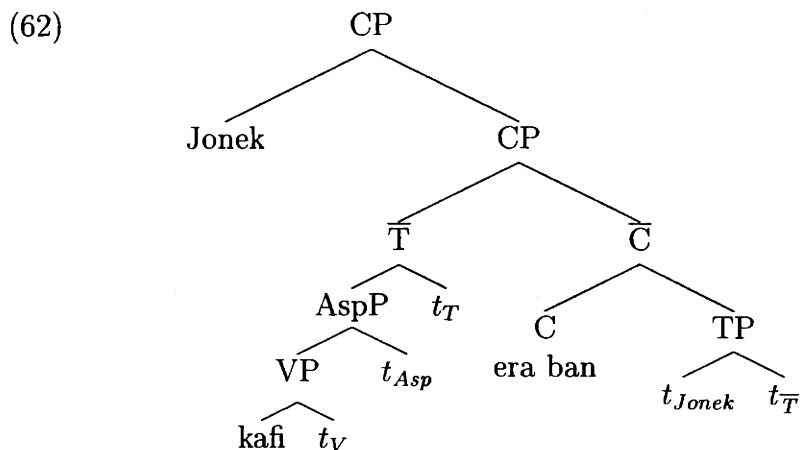

There are two potential problems with this structure, both related to the fact that the verbal complex moves out of the focused constituent. First, the trace of the verbal complex ( $t_T$ ) is not c-commanded by its antecedent. Second, the reading we are trying to obtain is one in which the verbal complex is part of the focused constituent. Both problems could be solved by reconstruction of the verbal complex back to T.

However, even if these problems are solved, this analysis misses an important generalization. The facts about focus projection are essentially the same in Basque and English: sentence stress on the object yields the same three focus readings in the two languages. In the framework assumed here, all the facts in both languages are captured in a unified way. In Ortiz de Urbina's analysis, the generalization is seen as an accident.

The same problem arises in Elordieta's (2001) "mixed" approach. As discussed in the previous section, she proposes two different mechanisms to derive the preverbal focus position. In some cases, it is the result of the interaction of the NSR and the requirement that the focused constituent contain sentence stress. For instance, this is her analysis of the transitive sentence in (59) above. In this case, her account of the focus projection facts in Basque is the same as the one defended here. However, she rejects the idea that there is rightward movement in Basque, which forces her to an analysis similar to Ortiz de Urbina's in cases in which there is some phrase following the verbal complex:<sup>21</sup>

<sup>21</sup>As discussed in footnote 13, there are some cases in which the presence of some phrase to the right of the verbal complex is not necessarily the result of movement of the verbal complex to its

- (63) **Káfi** era ban Jonek.  
 coffee.A.SG drink.PRF Aux.PST Jon.E  
*Jon drank COFFEE.*

This sentence has at least two readings: focus on the object (as an answer to *What did Jon drink?*), or focus on the object and verbal complex (as an answer to *What did Jon do?*).<sup>22</sup> In the analysis defended here, this sentence has the following structure:

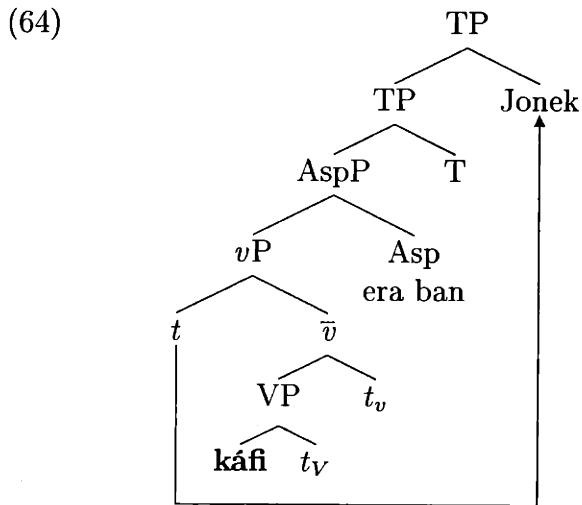

In this structure, the object *káfi* receives sentence stress. Thus, focus can be on the object or on the constituent containing both the object and the verbal complex (AspP), since both contain sentence stress.

On the other hand, the structure which Elordieta proposes for this sentence is the following:

left. This does not apply to the postverbal subject below.

<sup>22</sup>It also has a reading in which the whole clause is focused. This reading is somewhat obscured by the fact the postverbal subject must be understood as given. See §5.8.4 below.

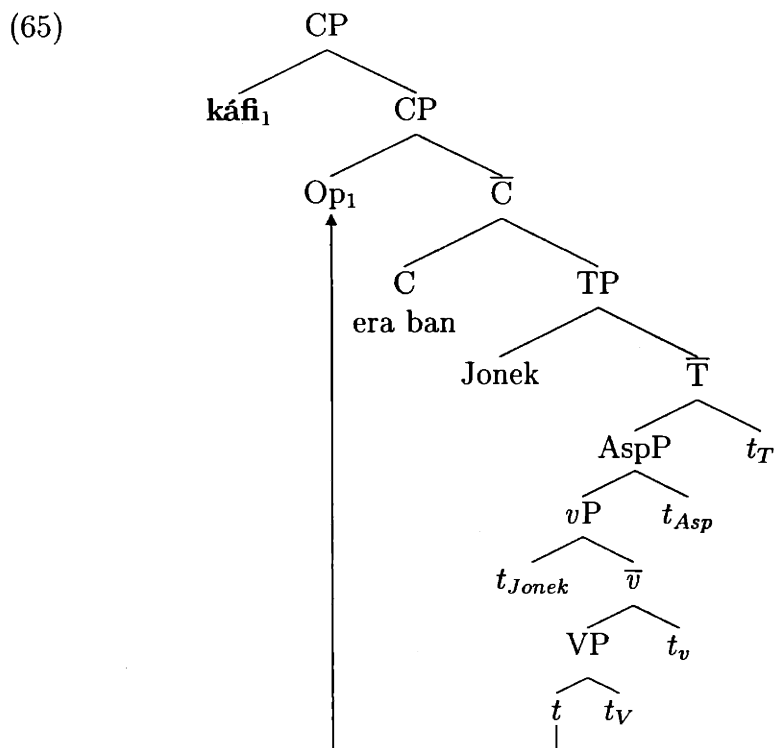

Her analysis has one important difference with respect to Ortiz de Urbina's: the focused constituent is not [Spec, CP], but adjoined to CP. [Spec, CP] is occupied by an empty operator (coindexed with the focused phrase) which moves there from inside TP. See Elordieta 2001 (§4.4.3) for details. This difference between her analysis and Ortiz de Urbina's, although reflected in the structure in (65), is not relevant for the point discussed here. The structure proposed by both authors for this sentence is, in all relevant respects, basically the same.

Elordieta's discussion of focus projection in sentences of this type is somewhat confusing. In page 140, she claims that sentences in which the focused phrase is in the left-peripheral position involve "narrow" focus, i.e. only the phrase in the left-peripheral position can be interpreted as focused. One of the sentences she gives in order to support this claim is the following (Elordieta's 105b on page 172).<sup>23</sup>

<sup>23</sup>This sentence is in Standard Basque. In Ondarroa Basque it would be:

(i) **Jonek** irakurri rau liburu.  
Jon.E read.PRF Aux.PR book.A.SG

- (66) **Jonek** irakurri du liburua.  
 Jon.E read.PRF Aux.PR book.A.SG  
*JON has read the book.*

In her analysis, the subject *Jonek* must be in the left-peripheral focus position, given that there is one phrase to the right of the verbal complex. This sentence, she claims, involves narrow focus on the subject, as predicted in her analysis.

On the other hand, on page 214, she reports the following judgement (Elordieta's 66):<sup>24</sup>

- (67) Adarra jo dio maisuak ikasleari.  
 horn.A.SG hit.PRF Aux.PR teacher.E.SG student.D.SG  
*The teacher has pulled the student's leg.*

She claims that this sentence is compatible with focus on the object and the verbal complex (*adarra jo dio*). This means that the object *adarra* is not in the left-peripheral position; rather, some constituent containing both the object and the verb are in that position.

If, in general, the verb together with some other constituent can appear in the left-peripheral focus position, it is not clear why this is not possible in (66) with the subject and the verbal complex. This would not be consistent with Elordieta's claim that only the preverbal constituent can be interpreted as focused in this sentence. In fact, according to my informant, (66) *can* have a reading in which the preverbal subject and the verbal complex are part of the focus. For instance, it can be an answer to *What happened to the book?*<sup>25</sup> If this judgement is not due to dialectal variation, then the contradiction found in Elordieta's text is solved.<sup>26</sup>

---

<sup>24</sup>This sentence is reported in Standard Basque in Elordieta 2001. In Ondarroa Basque, it would be:

- (i) **Adár**ra jo tza maxuak ikasliai.  
 horn.A.SG hit.PRF Aux.PR teacher.E.SG student.D.SG

<sup>25</sup>Admittedly, answering this question with (66) (*Jon read the book*) is odd, unless something bad happens to a book when Jon reads it. This minor problem is solved by using *apurtu* 'break' instead of *irakurri* 'read' in (66). The resulting sentence can be used as an answer to *What happened to the book?*

<sup>26</sup>In fact, although Elordieta claims that (66) can only be interpreted with narrow focus on the preverbal subject, she does not provide any context contradicting the claim that it can also be

That means, then, that in sentences in which there are postverbal constituents, such as (63, 66), Elordieta's analysis is forced to assume that the different focus readings are the consequence of constituents of different sizes appearing in [Spec, CP]. Thus, this analysis suffers from the same problem that we saw with Ortiz de Urbina's: focus projection facts are basically the same in English and Basque, but the analyses of the two languages are very different.

In this section, I have given a plausible argument that the analysis defended here provides a better account of focus in Basque than the ones found in Ortiz de Urbina 1989, 1994, 1995 and Elordieta 2001. These authors provide several arguments in favor of their analyses which I have not discussed so far. These arguments are discussed and countered in §5.9 and in §5.10. Specifically, Ortiz de Urbina presents evidence that focused constituents in Basque behave as *wh*-words in English (i.e. they move to [Spec, CP]). In §5.9, I discuss the relevant data, arguing that they are compatible with the analysis defended here. As discussed above, a central claim in Elordieta's analysis is that there is no right dislocation in Basque. In §5.10, I discuss the arguments she provides, arguing that the data is in fact compatible with an analysis in terms of right dislocation.

## 5.8 Basque Movements and Economy

### 5.8.1 The Problem

In the previous section, we saw that condition (68), repeated below as (51), accounts for several focus projection facts in Basque (and other languages):

- (68) The minimal phrase accessible to the NSR which contains the F-marked phrase in a sentence must contain the primary stress in that sentence.

This analysis seems to make wrong predictions in some cases:

- (69) Maxe        **Jónek** apurtu    rau.  
 table.A.SG Jon.E    break.PRF Aux.PR  
*Jon has broken the table.*

---

interpreted with focus on the subject and the verb.

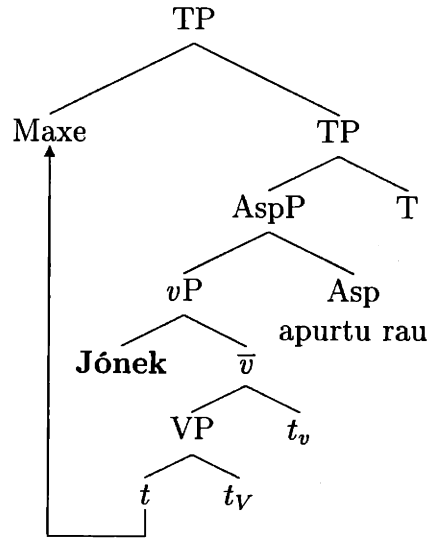

This sentence has two focus readings, each corresponding to the following questions:

- (70) a. *Focus on the subject:*

Maxe señek apurtu rau?  
table.A.SG who.E break.PRF Aux.PR

*Who has broken the table?*

- b. *Focus on the subject and the verbal complex:*

Maxai se pasa gako?  
table.D.SG what.A happen.PRF Aux.PR

*What happened to the table?*

These two readings are predicted by the present analysis. Sentence stress is on the subject *Jonek*. Thus, the sentence can be understood with focus on the subject. There is also a constituent containing only the subject and the verbal complex (AspP), so this constituent can also be understood as focused.

However, the analysis predicts that this sentence can also be interpreted with focus on the whole clause, since the clause, obviously, contains sentence stress. This prediction is not borne out: this sentence is not a possible answer to *What hapened?* One could propose the following solution to this problem. Compare, first, the sentence in (69), repated below as (71b), with one in which the object is not left dislocated (71a):

- (71) a. Jonek **máxe** apurtu rau.  
 Jon.E table.A.SG read.PRF Aux.PR  
*Jon has broken the table.*

Focus readings:  $\text{Obj}_F$ ,  $[\text{Obj V-Aux}]_F$ ,  $[\text{Sbj Obj V-Aux}]_F$

- b.  Máxe **Jónék** *t* apurtu rau.  
 table.A.SG Jon.E break.PRF Aux.PR  
*Jon has broken the table.*

Focus readings:  $\text{Sbj}_F$ ,  $[\text{Sbj V-Aux}]_F$

Interestingly, the only readings available to the sentence with left dislocation ( $\text{Sbj}_F$  and  $[\text{Sbj V-Aux}]_F$ ) are precisely the ones that are not available for the sentence without left dislocation. It seems that what motivates left dislocation, at least in this case, is the need to express some reading which is not available without it. This suggests an economy condition similar in spirit to others that have been proposed in the literature (e.g. Chomsky 1995, Reinhart 1995, Fox 2000). In particular, one could propose that left dislocation is possible only if it results in some focus reading which would not be available to the sentence otherwise. This would account for the limited set of readings that (71b) has, i.e. only the ones that are not available to (71a).

In fact, analyses along this lines has been proposed by several authors for similar phenomena in other languages. For instance, Zubizarreta 1998 proposes something along these lines for Romance.<sup>27</sup>

In Elordieta 2001 (pp. 138-142), a similar proposal is made for these data in Basque. In the remainder of this section, I provide an alternative analysis of these facts in Basque which does not rely on economy. The basic idea is that left a dislocated phrase in Basque is necessarily understood as topic, and that this fact explains why sentences with left dislocated elements do not have all the expected focus readings. In particular, in (71b) above, the left dislocated object is interpreted as a topic. Since, as discussed below, a topic cannot be part of the focus of a sentence, any reading in

<sup>27</sup>As formulated above, the economy condition relies on global economy, i.e. it compares the interpretations available to different (but related) sentences. Zubizarreta avoids this by building the economy condition into the movement rule. See Zubizarreta 1998 (§3.3–3.5) for details.

which the object is part of the focus is ruled out. Therefore, the economy condition is not necessary.

### 5.8.2 The Semantics of Topic

Before we turn to the analysis of the Basque data, we need to clarify what is meant by ‘topic’. I adopt Büring’s (1997) theory of the semantics of topics. In this framework, a sentence  $\phi$  has three semantic values: an ordinary semantic value  $[[\phi]]^o$ , a focus value  $[[\phi]]^f$ , and a *topic value*  $[[\phi]]^t$ . As we saw in §5.2, the focus value of a sentence in Rooth’s (1985) theory is a set of propositions. The topic value of a sentence in Büring’s theory is a set of focus values, i.e. a set of sets of propositions. Consider, for instance, the following English example (Büring’s 39 on p. 66; subscript  $T$  is used to mark the topic):

(72)  $[I]_T$  would buy [*The Hotel New Hampshire*]<sub>F</sub>.

The focus value of this sentence is a set of propositions which contain alternatives to the focused constituent:

(73) {I would buy *War and Peace*, I would buy *The Hotel New Hampshire*, I would buy *The World According to Garp*, ... }

The topic value is a set of such sets, with alternatives to the topic:

(74) { {I would buy *War and Peace*, I would buy *The Hotel New Hampshire*, I would buy *The World According to Garp*, ... },  
 {Bolle would buy *War and Peace*, Bolle would buy *The Hotel New Hampshire*, Bolle would buy *The World According to Garp*, ... },  
 {Fritz’s brother would buy *War and Peace*, Fritz’s brother would buy *The Hotel New Hampshire*, Fritz’s brother would buy *The World According to Garp*, ... }, ... }

In other words, the focus value of this sentence is a set of propositions of the form *I would buy y*, and the topic value is a set of sets of propositions of the form *x would buy*

*y*. In this theory, the meaning of topic and focus are related, in that the topic value of a sentence is a set of focus values, and a focus value is in turn a set of ordinary values.<sup>28</sup>

This definition of topic accounts for a number of facts. Consider the role that topics have in answers to multiple questions, as in the following English example (from Jackendoff 1972):<sup>29</sup>

(75) Q: Who ate what?

A: [Fred]<sub>T</sub> ate [the beans]<sub>F</sub>.

A': [Fred]<sub>F</sub> ate [the beans]<sub>F</sub>.

A is a partial answer to Q. In Büring's (1997) theory, the topic value of A is a set of sets of propositions of the form *x ate y*, i.e. the ordinary value of the question. Topic marking is crucial in partial answers to multiple questions:<sup>30</sup> if the answer does not contain topic marking on some constituent, but just focus, as in A', it would not be a partial answer. Rather, it would be a final answer to the question.

Another common use of topics is as *contrastive topics*, as illustrated in the following:

(76) Q: Which book would Fritz buy?

A: Well, [I]<sub>T</sub> would buy [*The Hotel New Hampshire*]<sub>F</sub>.

In this case, A is not an answer to Q. Rather, it is an answer to the related question *Which book would you buy?* These two questions are subparts of the more general question *Who would buy which book?* By marking the subject as topic in A, the speaker is giving a partial answer to a question that is more general than Q.

The following is another example of the effect of topic-marking:

<sup>28</sup>This might suggest that the notions *focus* and *topic* could be collapsed. Büring (1997) provides evidence against this possibility.

<sup>29</sup>In English, foci and topics are marked intonationally with two different pitch accents (the *A* and *B* accent, respectively). See, among others, Bolinger 1965, Pierrehumbert 1980, Liberman and Pierrehumbert 1984.

<sup>30</sup>The topic does not have to be the subject in this sentence. For instance, another possible partial answer to this question would mark the object as topic and the subject as focus. See Jackendoff 1972 and Büring 1997 for discussion.

(77) Q: What did you give John?

A: I gave [John]<sub>T</sub> [a book]<sub>F</sub>.

A is a complete answer to Q. However, by marking the indirect object as topic, it is also a partial answer to the more general question *Who did you give what?* The speaker is thus implying that he gave things to other people as well.

In the next section, I show that left dislocated elements in Basque are interpreted as topics, and I argue that this fact explains why sentences with left dislocation do not have all the expected focus readings, thus rendering the economy condition suggested in the previous section unnecessary.

### 5.8.3 Left Dislocation

As is well known from the literature on Basque, left dislocated elements are topics (cf. de Rijk 1978, Mitxelena 1981, Eguskita 1986, Ortiz de Urbina 1989). Consider again the left dislocation example in (71b), repeated below as (78):

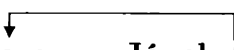
(78)  Maxe      **Jónek** *t* apurtu      rau.  
table.A.SG Jon.E      break.PRF Aux.PST  
*Jon has broken the table.*

In this sentence, the left dislocated object is understood as a topic. To see how this is the case, consider the following possible answers to *Who broke the table?*:

(79) Señek apurtu      ban      maxe?  
who.E break.PRF Aux.PST table.A.SG  
*Who broke the table?*

A: **Jónek** apurtu      ban      (maxe).<sup>31</sup>  
Jon.E break.PRF Aux.PST table.A.SG

A': Maxe      **Jónek** apurtu      ban.  
table.A.SG Jon.E break.PRF Aux.PST

<sup>31</sup>Subjects, direct and indirect objects can be covert in Basque. These are also the arguments that the tensed verb agrees with. In this sentence, there is a slight preference to omit the object, probably not to be repetitive. As in other languages, the most felicitous answer is one in which only the focus is overt, i.e. *Jonek*.

Both A and A' are complete answers to the question. However, A', where the object *maxe* is left dislocated, introduces something else. Specifically, it suggests that there are other objects about which we should be asking who broke them. That is, A' is also a partial answer to the question *Who broke what?* This means that the left dislocated object is interpreted as a topic, in the sense defined in the previous section:

- (80) Left dislocated XPs are interpreted as topics.

The following illustrates another use of left dislocation as topic:

- (81) Q: Señek topa ban Jon?  
 who.E find.PRF Aux.PST Jon.A  
*Who found Jon?*
- A: (es tai, bañe) Aitor neuk topa neban.  
 not know.PR but Aitor.A I.E find.PRF Aux.PST  
*(I dont know, but) I found Aitor.*

The left dislocated subject in the answer is interpreted as a contrastive topic. As in the English example in (76), A is not an answer to Q, but to a related question (*Who did you find?*).

The fact that left dislocated constituents are interpreted as topics explains why sentences with left dislocation do not have all the expected focus readings. Consider the problematic example in (71b) again, repeated here as (82):

- (82)  Maxe Jónek t apurtu rau.  
 table.A.SG Jon.E break.PRF Aux.PST  
*Jon has broken the table.*
- Focus readings: Sbj<sub>F</sub>, [Sbj V-Aux]<sub>F</sub>, \*[Obj Sbj V-Aux]

Since the clause contains sentence stress, it would be expected that this sentence can be understood with focus on the whole clause. As we saw above, this is not possible; this sentence cannot be an answer to *What happened?*

What we need to explain, then, is why this sentence is not a possible answer to *What happened?* Given what we saw in the previous section, the answer is obvious.

Since the object is left dislocated, it is interpreted as a topic. This means that this sentence is a partial answer to *Who broke what?*, but, crucially, not to *What happened?*

Quite generally, left dislocated elements are topics, which means that they are excluded from the focus of the sentence. Thus, it is expected that a sentence in which there is left dislocation has less focus readings than the corresponding sentence without left dislocation. This is illustrated further in the following sentences:

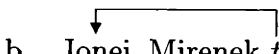
- (83) a. Mirenek Jonei **libúro bat** emo tzan.  
 Miren.E Jon.D book a.A give.PRF Aux.PST  
*Miren gave Jon a book.*
- b.  Jonei Mirenek *t* **libúro bat** emo tzan.  
 Jon.D Miren.E book a.A give.PRF Aux.PST

The left dislocated indirect object in (83b) is a topic. For instance, it can be used in the following context, where it is interpreted as a contrastive topic:

- (84) A: Mirenek Aitorrei se emo tzan?  
 Miren.E Aitor.D what.A give.PRF Aux.PST  
*What did Miren give Aitor?*
- B: Es tai, bañe Jonei Mirenek **libúro bat** emo tzan.  
 not know but Jon.D Miren.E book a.A give.PRF Aux.PST  
*I don't know, but Miren gave Jon a book.*

Furthermore, (83b), as opposed to (83a) cannot be interpreted with focus on the whole sentence; it cannot be an answer to *What happened?* This is explained in the same way as in the previous sentence: the left dislocated indirect object is a topic, which means that it is excluded from the focus.

To conclude, the fact that left dislocated constituents are topics explains why sentences containing them do not have all the expected focus readings. Thus, the economy condition suggested in §5.8.1 is not necessary to explain the facts.

#### 5.8.4 Right Dislocation

A problem similar to the one we saw with left dislocation also arises in sentences with right dislocation:

- (85)  $\overbrace{t \text{ J} \acute{u}n \quad \text{ein} \quad \text{san} \quad \text{Jon.}}^{\downarrow}$   
 arrive.PRF do.PRF Aux.PST Jon.A.SG  
*Jon left.*

This sentence can be understood with focus on the verb (as an answer to the question *What did Jon do?*) This is as expected, since the verb contains sentence stress. However, it seems that, in “out of the blue” contexts, it cannot be an answer to *What happened?* This would suggest that the right dislocated subject cannot be part of the focus, even though there is a constituent, the whole clause, that contains both the verb and the subject. This is not as expected, since the clause contain sentence stress.

This problem, again, suggests an economy condition similar to the one suggested (and rejected) earlier for left dislocation: right dislocation is possible only if it results in a focus reading that would not be available had the movement not applied. It seems that right dislocation serves the function of removing the moved element from the focused constituent. In the remainder of this section, I argue that this economy condition is not necessary for right dislocation either. The argument is similar to the one involving left dislocation, except that in this case, it shows that the economy condition actually makes wrong predictions. Specifically, I argue that right dislocation also has a specific discourse function: right dislocated elements are understood as *given*. Once this is taken into account, it turns out that sentences with right dislocation *do* have all the focus readings expected in the present analysis. Since the economy condition would predict that some of these readings are not available, it has to be rejected.

Let us illustrate the concept of givenness with the following English example (see, among others, Selkirk 1995, Schwarzschild 1999):

- (86) After buying the book, I read the book.

In this sentence, the second occurrence of *the book* must be pronounced destressed. If it is pronounced with nuclear stress on *the book* (as would be expected given the NSR), it is not grammatical. In general, a phrase is destressed in English when its

denotation has been mentioned previously in the discourse, i.e. when it is *given*.<sup>32</sup> This can also be exemplified with third person pronouns, since they are normally understood as given:

(87) Q: What did Jonh's mother do?

A: She praised him.

In this example, if *him* refers to John, it must be distressed. Even though in this sentence the VP *praised him* is focused, the pronoun must be distressed because it is given.<sup>33</sup>

Consider now the counterpart of (86) above in Basque:

(88) Liburu erosi txe gero, ...  
 book.A.SG buy.PRF and later  
*After buying the book ...*

a. #... liburu irakurri neban.  
 book.A.SG read.PRF Aux.PST  
 ... *I read the book.*

b. ... t irakurri ein neban liburu.  
 read.PRF do.PRF Aux.PST book.A.SG  
 ... *I read the book.*

In this example, *liburu* 'the book' is mentioned in the first part of the sentence. In the continuation, the second occurrence of *liburu* must be right dislocated. Thus, we can conclude:

(89) Right dislocated XPs are interpreted as given.

Consider again the problematic example (85), repeated below as (90):

<sup>32</sup>This oversimplified informal definition is sufficient for our purposes. See Schwarzschild 1999, and references cited there, for discussion.

<sup>33</sup>This is only a partial discussion of the relevant facts in English which will be useful below in understanding the discourse properties of right dislocation in Basque. See the references cited above for discussion.

- (90)  $\overbrace{t \text{ J} \acute{u} \text{n} \quad \text{ein} \quad \text{san} \quad \text{Jon.}}^{\downarrow}$   
 arrive.PRF do.PRF Aux.PST Jon.A.SG  
*Jon left.*

As mentioned above this sentence cannot be interpreted with focus on the whole clause in “out of the blue” contexts. However, the present analysis predicts that the whole clause can be interpreted as focused as long as the right dislocated element is interpreted as given. This prediction is borne out:

- (91) Q: Jonek klasi      amatxu   te   gero, se      pasa      san?  
 Jon.E class.A.SG finish.PRF and later what.A happen.PRF Aux.PST  
*After Jon finished the class, what happened?*
- A: **J**  $\acute{u}$  **n**      ein      san      Jon.  
 go.PRF do.PRF Aux.PST Jon.A  
*Jon left.*

The sentence is an answer to *What happened?* which means that, in this particular context, it can be understood with focus on the whole clause. The crucial difference between this context and an “out of the blue” context is that *Jon* is given, since it is mentioned in the question. Thus, both right dislocation and focus on the whole sentence are licensed.

To summarize, right dislocated phrases are interpreted as given. Once we take this fact into account, we can see the economy condition suggested above makes wrong predictions, since right dislocation does not necessarily result in the moved element being outside of the focus.

## 5.9 Long Distance Dependencies

In the preceding sections, I have examined the syntax of focused and *wh*-phrases (*wh/f*-phrases) in Basque simple sentences, arguing that their main properties are derived from the interaction of movement and prosodic conditions imposed on them. In this section, I study more complex cases in which embedded clauses are involved. More specifically, I discuss different strategies that are used in this language in order to focus and assign matrix scope to embedded *wh/f*-phrases.

Given that in simple clauses *wh/f*-phrases do not need to move, one might expect that Basque does not need long distance movement for establishing long distance dependencies with *wh/f*-phrases. However, apart from the expected *in-situ* strategy, this language also uses another one which involves long distance movement, as argued for by Ortiz de Urbina (1989, 1994, 1995). In this section, I discuss long distance movement first (§5.9.1), and then the *in-situ* strategy (§5.9.2), and provide an account within the general framework assumed here.

### 5.9.1 Long Distance Movement

Long distance movement is exemplified in the following sentences:

- (92) a. **Séin** pentzate su [CP Mirenek ikusi rabela ]?  
 who.A think.IMP Aux.PR Miren.E see.PRF Aux.PR.COMP  
*Who do you think Miren saw?*
- b. **Jón** pentzaten dot [CP Mirenek ikusi rabela ].  
 Jon.A think.IMP Aux.PR Miren.E see.PRF Aux.PR.COMP  
*I think Miren saw JON.*

In both cases, the *wh/f*-phrase has sentence stress. However, since the *wh/f*-phrase is separated from the embedded clause in which it was generated, it also appears that these sentences involve extraction of the *wh/f*-phrase from the embedded clause. This might be seen as a problem for the analysis defended here, since this movement would, in principle, place the moved *wh/f*-phrase in a position where it would not receive sentence stress.

Ortiz de Urbina (1989) gives examples of this type as evidence for his analysis. As we saw in §5.6, in this account, *wh/f*-phrases move to [Spec, CP], and the verbal complex moves to C:

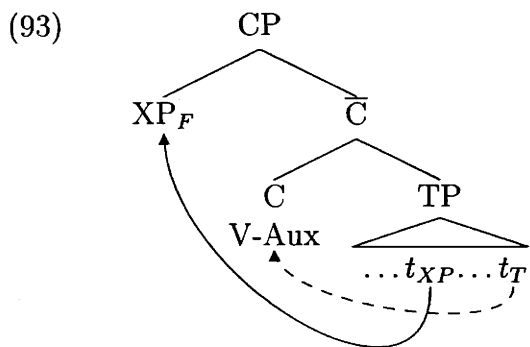

In this approach, the sentences like the ones in (92) receive a straightforward analysis. They involve long distance movement of the *wh/f*-phrase from the embedded clause to the matrix [Spec, CP], just as in the English counterpart to the *wh*-question in (92a):<sup>34</sup>

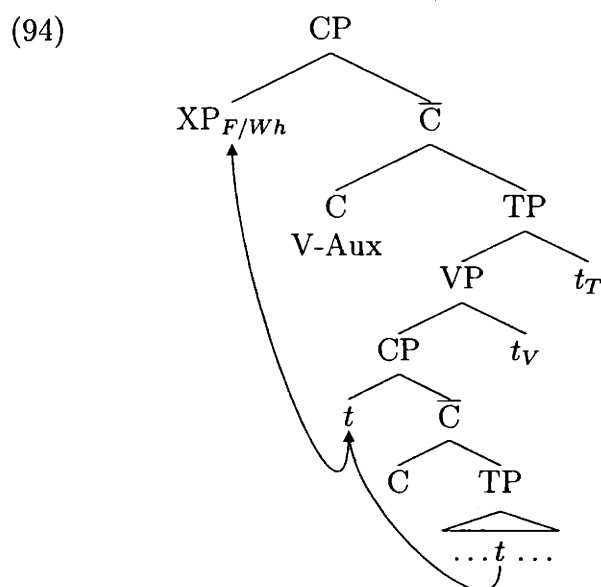

An analysis along these lines is clearly incompatible with the approach defended in this thesis. In the moved position, the *wh/f*-phrase cannot be assigned sentence stress by the NSR.

Ortiz de Urbina provides further evidence for his analysis from the domain of islands. For instance, the movement posited in this account is sensitive to complex NP islands (95) and to adjunct islands (adapted from Ortiz de Urbina 1989, p. 252):

<sup>34</sup>I have ignored the *v* and Asp projections for ease of exposition. I have also ignored the subject in the matrix clause, which is *pro*.

- (95) a. \***Séñek** irakurri ban Peruk [DP[DP*t* idatzi ban ]  
 who.E read.PRF Aux.PST Peru.E write.PRF Aux.PST.COMP  
 liburu ]?  
 book.A.SG  
*Who did Peru read the book wrote?*
- b. \***Jónek** irakurri ban Peruk [DP[DP*t* idatzi ban ]  
 Jon.E read.PRF Aux.PST Peru.E write.PRF Aux.PST.COMP  
 liburu ].  
 book.A.SG  
*Peru read the book that JON wrote.*
- (96) a. \***Se** jun sin amendik [ *t* ikusi txe gero ]?  
 what.A go.PRF Aux.PST here.ABL see.PRF and later  
*What did they leave after seeing?*
- b. \***Máxe** jun sin amendik [ *t* ikusi txe gero ].  
 table.A.SG go.PRF Aux.PST here.ABL see.PRF and later  
*They left after seeing the TABLE.*

These facts convincingly show that the sentences in (92) involve long distance movement.

There are two questions that the analysis defended here needs to answer in order to address the problem raised by sentences like (92). First, the *wh/f*-phrase receives sentence stress, but it is not clear how this can be so if it is extracted from the embedded clause. Second, the embedded clause appears to the right of the verbal complex, which is not expected in a V-final language like Basque.

In Ortiz de Urbina 1989, the second question is answered by positing a left-headed CP, and moving the verbal complex to C. This option is not available to us, since, as argued in §4, the participle and the auxiliary form two separate heads in the syntax. The only way in which the embedded clause can be to the right of the verbal complex is via rightward movement. In fact, even though VP is right-headed in Basque, there is a general preference to place complement clauses to the right of the verb. For instance, (97b) below is as acceptable as (97a).<sup>35</sup>

<sup>35</sup>In the examples below, I abstract away from any possible effect that rightward movement of embedded clauses might have on discourse. I leave this as a question for future research.

- (97) a. Jonek [<sub>CP</sub> Miren jun dala ] pentzaten dau.  
 Jon.E Miren.A go.PRF Aux.PR.COMP think.IMP Aux.PR  
*Jon thinks that Miren has left.*

- b. Jonek  $t$  pentzaten dau [<sub>CP</sub> Miren jun dala ].  
 Jon.E think.IMP Aux.PR Miren.A go.PRF Aux.PR.COMP

Let us assume that this movement adjoins the embedded CP to the matrix TP. I would like to propose that the long distance extraction cases we saw above in (92) also involve rightward movement of the embedded clause.

This answers the second question posited above. The fact that the embedded clause in (92) appears to the right of the verb is the result of rightward movement. This, in turn, helps in answering the first question, namely, how the extracted *wh/f*-phrase obtains sentence stress. Since rightward movement creates an adjunction structure, extraction of the *wh/f*-phrase must occur *before* rightward movement of the embedded clause. Otherwise, there would be a violation of the adjunct island condition. All that we need, then, to make these sentences compatible with our analysis is to extract the *wh/f*-phrase to a position in which they receive sentence stress. I would like to propose that this movement adjoins the *wh/f*-phrase to the matrix *vP*. Thus, the sentences in (92) involve two steps. First, the *wh/f*-phrase is extracted from the embedded clause and adjoined to the matrix *vP*:<sup>36</sup>

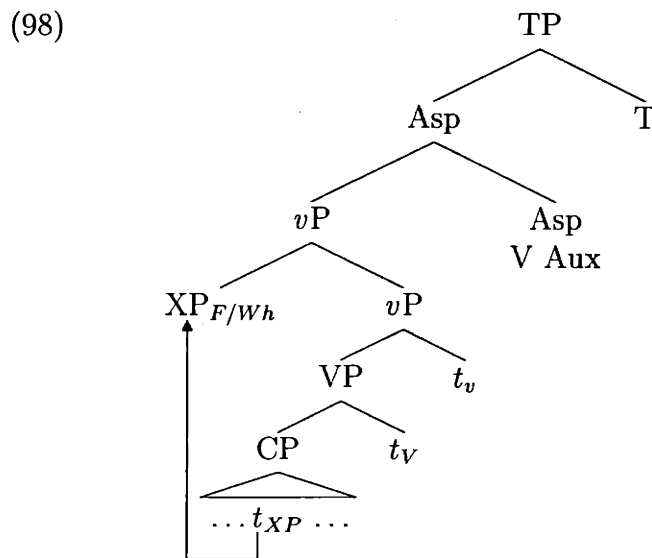

<sup>36</sup>In the structures below, I abstract away from the possibility that the movement of the *wh/f*-phrase might undergo certain intermediate steps (e.g. through [Spec, CP] in the embedded clause).

Second, the embedded CP moves to the right, to be adjoined to the matrix CP:

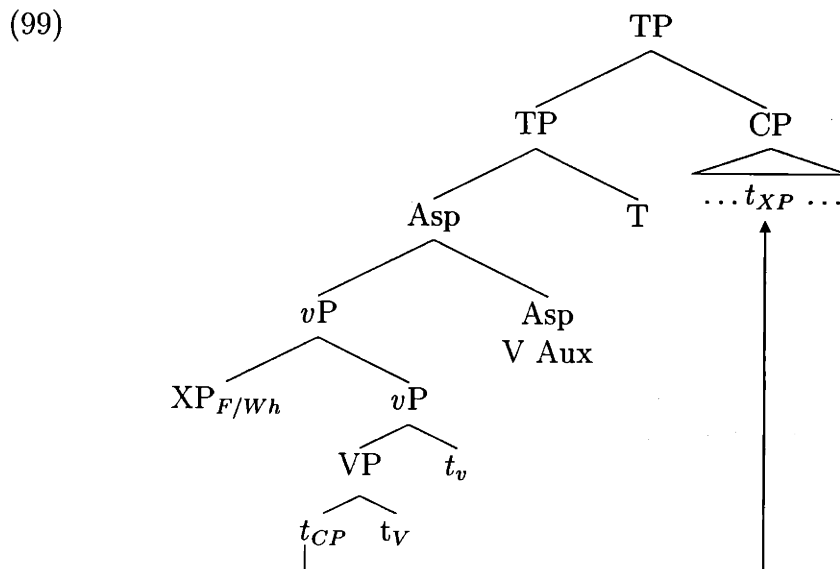

In the resulting structure, the extracted *wh/f*-phrase is in a position in which it is assigned sentence stress by the NSR, since it is the only overt constituent inside the matrix *vP*. In (92), this is the case because the only other constituent that could be in the matrix *vP* is the covert matrix subject (*pro*). If, on the other hand, the matrix subject (or any other constituent generated in *vP*) is overt, it must move out of *vP*. If it did not, the *wh/f*-phrase would not receive sentence stress. The result is that the extracted *wh/f*-phrase must be left adjacent to the matrix verbal complex. As shown by Ortiz de Urbina (1989), this is indeed the case:

- (100) a. (Jonek) **Séin**<sub>1</sub> (\*Jonek) pentzaten dau (Jonek) jun  
 Jon.E who.A think.IMP Aux.PR go.PRF  
 sanela?  
 Aux.PR.COMP  
*Who does Jon think left?*
- b. (Jonek) **Míren**<sub>1</sub> (\*Jonek) pentzaten dau (Jonek) jun  
 Jon.E Miren.A think.IMP Aux.PR go.PRF  
 sanela.  
 Aux.PR.COMP  
*Jon thinks MIREN left.*

To summarize so far, the examples of long distance extraction are compatible with the analysis of *wh/f*-phrases proposed in this chapter. Furthermore, the two

movements that have been posited are independently motivated. First, movement of the embedded CP to the right can occur whether there is long distance extraction or not. Second, movement of the *wh/f*-phrase to the matrix *vP* is motivated by the need to receive sentence stress.

### 5.9.2 *Wh/F in situ*

As we saw in the previous section, embedded *wh/f*-phrase can undergo long distance movement. However, this is not the only strategy available to embedded *wh/f*-phrases. What, in principle, looks like an *in situ* strategy is also possible:

- (101) a. [CP Mirenek **séin** ikusi rabela ] pentzate su?  
 Miren.E who.A see.PRF Aux.PR.COMP think.IMP Aux.PR  
*Who do you think Miren saw?*
- b. [CP Mirenek **Jón** ikusi rabela ] pentzaten dot.  
 Miren.E Jon.A see.PRF Aux.PR.COMP think.IMP Aux.PR  
*I think Miren saw JON.*

These cases might be seen as an argument against Ortiz de Urbina's (1989) approach, since, apparently, they do not involve movement of the *wh/f*-phrase. However, Ortiz de Urbina makes two crucial observations. First, the *wh/f*-phrase within the embedded clause must be left-adjacent to the embedded verbal complex (102). Second, the embedded clause must be left-adjacent to the matrix verbal complex (103):

- (102) a. \*[CP **Séin** Mirenek ikusi rabela ] pentzate su?  
 who.A Miren.E see.PRF Aux.PR.COMP think.IMP Aux.PR  
*Who do you think Miren saw?*
- b. \*[CP **Jón** Mirenek ikusi rabela ] pentzaten dot.  
 Jon.A Miren.E see.PRF Aux.PR.COMP think.IMP Aux.PR  
*I think Miren saw JON.*
- (103) a. \*[CP Mirenek **séin** ikusi rabela ] suk pentzate su?  
 Miren.E who.A see.PRF Aux.PR.COMP you.E think.IMP Aux.PR  
*Who do you think Miren saw?*
- b. \*[CP Mirenek **Jón** ikusi rabela ] nik pentzaten dot.  
 Miren.E Jon.A see.PRF Aux.PR.COMP I.E think.IMP Aux.PR  
*I think Miren saw JON.*

In Ortiz de Urbina's analysis, obligatory adjacency between an XP and the verbal complex is analyzed in terms of movement of XP to [Spec, CP] and of the verbal complex to C. Thus, these sentences, he argues, involve movement of the *wh/f*-phrase to [Spec, CP] within the embedded clause, and movement of the embedded clause to the matrix [Spec, CP]. Within both clauses, the verbal complex moves to C:

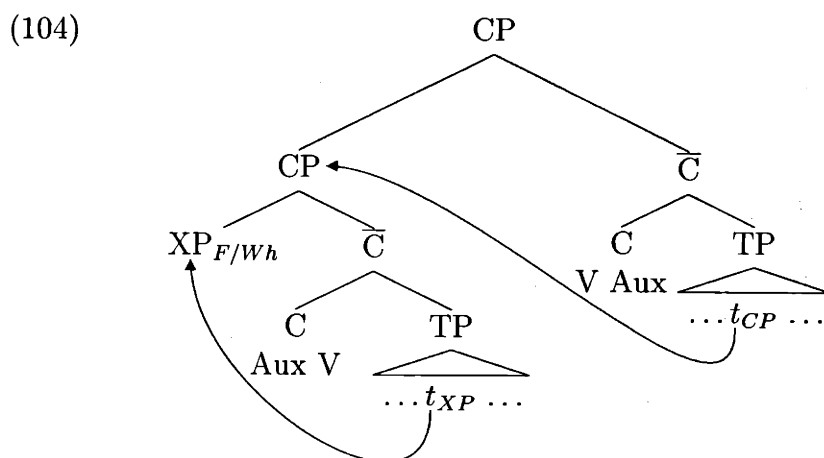

We can view this strategy as movement of the *wh/f*-phrase which carries along the whole embedded clause. Ortiz de Urbina, accordingly, calls this strategy *clausal pied-piping*.

As evidence for the view that these sentences involve clausal pied-piping, Ortiz de Urbina argues that it can involve long distance movement of the embedded clause:

- (105) [CP **Séin** jun sanela ] pentzate su t esa banela  
 who.A go.PRF Aux.PR.COMP think.PRF Aux.PR say.PRF Aux.PST  
 Jonek?  
 Jon.E  
*Who do you think Jon said left?*
- (106) [CP **Míren** jun sanela ] pentzaten dot t esa banela  
 Miren.A go.PRF Aux.PR.COMP think.PRF Aux.PR say.PRF Aux.PST  
 Jonek.  
 Jon.E  
*I think Jon said MIREN left.*

In these examples, the most deeply embedded clause (*Sein/Miren jun sanela* 'that who/Miren left') is moved to the left of the matrix clause (i.e. to [Spec, CP] in Ortiz de Urbina's analysis).



- (108) [CP **Séin** jun sanela ] pentzate su  $t_{CP}$  esa banela  
 who.A go.PRF Aux.PR.COMP think.PRF Aux.PR say.PRF Aux.PST  
 Jonek?  
 Jon.E  
*Who do you think Jon said left?*
- (109) [CP **Míren** jun sanela ] pentzaten dot  $t_{CP}$  esa  
 Miren.A go.PRF Aux.PR.COMP think.PRF Aux.PR say.PRF  
 banela Jonek.  
 Aux.PST Jon.E  
*I think Jon said MIREN left.*

These sentences are obvious cases of movement of the most deeply embedded clause, since it is not adjacent to the verb it is generated as a complement of (i.e. *esan* 'say'). In order to account for sentences of this type, I will follow the same strategy that was used to account for the cases of long distance movement discussed in the previous section.

For ease of exposition, we can schematize these sentences as follows:

- (110) [CP<sub>1</sub> [CP<sub>3</sub> ... XP<sub>F/Wh</sub> V-Aux<sub>3</sub> ...] V-Aux<sub>1</sub> [CP<sub>2</sub> ...  $t_{CP_3}$  V-Aux<sub>2</sub> ...] ]

There are two questions that the analysis defended here needs to answer in order to address the problem raised by these sentences. First, the *wh/f*-phrase receives sentence stress, but it is not clear how this can be so if the clause containing it (CP<sub>3</sub>) is extracted to some higher position in the matrix clause (CP<sub>1</sub>). Second, the intermediate clause (CP<sub>2</sub>) appears to the right of the matrix verbal complex V-Aux<sub>1</sub>, which is not expected in a V-final language like Basque.

The second question was already answered in the previous section: embedded clauses tend to appear to the right of the verb via rightward movement, regardless of whether some constituent has been extracted from them or not. This explains why CP<sub>2</sub> is to the right of the matrix verbal complex. This, in turn, helps in answering the first question. Since rightward movement of the CP<sub>2</sub> creates an adjunction structure, extraction of CP<sub>3</sub> occurs before rightward movement so that CP<sub>3</sub>, and consequently, the *wh/f*-phrase within it, is made more prominent than other constituents in the sentence. As in the cases of long distance movement discussed in the previous section,

I propose that CP3 moves to be adjoined to the matrix *v*P. Thus, the derivation of these sentences involves two basic steps. First, CP3 is extracted from CP2 targeting the matrix *v*P:

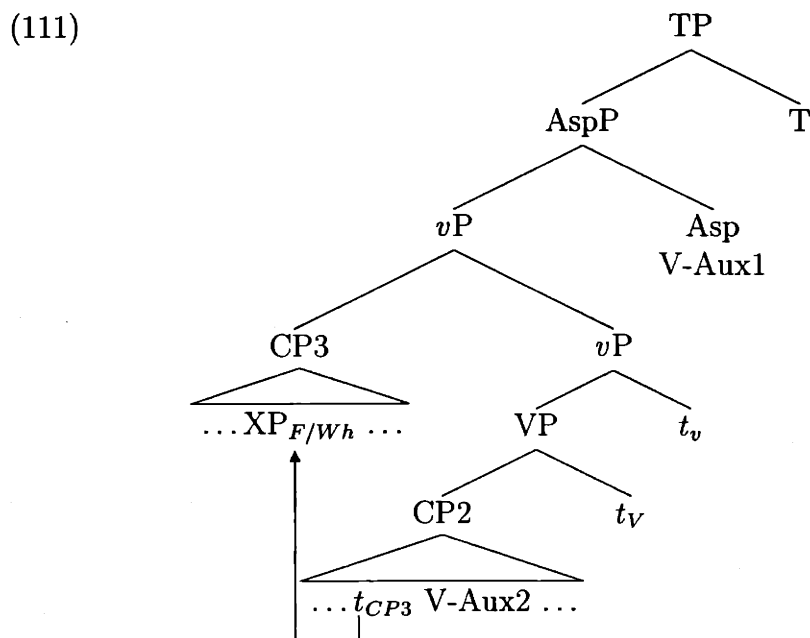

Second, CP2 is moved to the right:

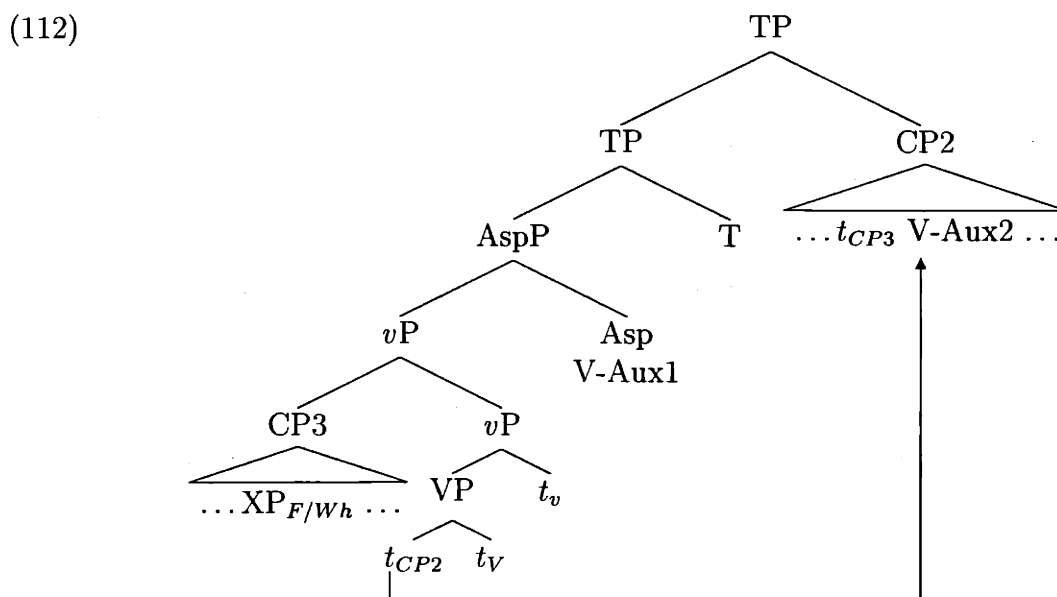

The resulting structure derives all the relevant word order facts (i.e. 110). Furthermore, it also derives that the *wh/f*-phrase has sentence stress. Within the matrix clause, CP3 receives more prominence than any other constituent, and within CP3, the *wh/f*-phrase receives more prominence than any other constituent.

In sum, the data examined in this section are compatible with the analysis of *wh/f*-phrases in Basque defended in this thesis. In all the relevant cases, the *wh/f*-phrase is in a position in which it is assigned sentence stress by the NSR. Thus, even though Ortiz de Urbina provides convincing arguments that some of the sentences must involve movement of the *wh/f*-phrase (or an embedded clause containing it), his conclusion that this must be movement to [Spec, CP] is not warranted.

### 5.10 Basque Movements and Reconstruction

In this section, I provide further evidence for right dislocation in Basque. As we saw at several points in this thesis, the hypothesis that phrases appearing to the right of the verb are right dislocated is crucial for several claims. First, it allows us to explain sentence stress in Basque in the same way that it is accounted for in other languages. Second, it is also an essential ingredient of the account of the preverbal focus position proposed in this chapter. Thus, the arguments presented in this section in favor of right dislocation provide further support for the general approach to the interface between syntax, phonology and discourse adopted in this thesis.

The main argument presented in this section can be summarized as follows. First, I provide evidence from variable binding that argues that left dislocation alters scope relations. This means that the order of constituents that are before the verbal complex matters for scope relations: in the SOV order, S outscopes O, and in the OSV order, O outscopes S. Second, I argue that placing constituents to the right of the verbal complex does not alter scope relations; the constituent behaves as if it were in its base position. In other words, in the orders SVO, OVS, VSO and VOS, the subject always outscopes the object. I provide the following analysis of these facts. (i) Basque has both left and right dislocation; (ii) left dislocation does not reconstruct; and (iii) right dislocation reconstructs obligatorily.

I compare this analysis with the one found in Elordieta 2001. As discussed in this and previous chapters, Elordieta proposes that there is no right dislocation in Basque. Cases in which one or more constituents appear to the right of the verbal complex are analyzed in terms of leftward movement of the verbal complex to C. At

the end of this section, I evaluate some of the arguments provided by Elordieta, and argue that the data she discusses is in fact compatible with the analysis proposed here. Furthermore, I argue that certain crucial data that are not discussed by this author provides evidence for rightward movement over the approach proposed in that work.

Consider the following sentences:<sup>37</sup>

- (113) a. Andra bakotxak<sub>1</sub> beran<sub>1</sub> semi ekarri ban.  
 woman each.E.SG her son.A.SG bring.PRF Aux.PST  
*Each woman<sub>1</sub> brought her<sub>1</sub> son.*
- b. \*Beran<sub>1</sub> amak mutil bakotxe<sub>1</sub> ekarri ban.  
 his mother.E.SG boy each.A.SG bring.PRF Aux.PST  
*His mother brought each woman.*

As shown in these examples, in the neutral SOV order, a QP subject can bind a pronoun inside the object, but a QP object cannot bind a pronoun inside the subject. These binding relations are altered if the object is dislocated to the left of the subject:

- (114) a. \*Beran<sub>1</sub> semi andra bakotxak<sub>1</sub> ekarri ban.  
 her son.A.SG woman each.E.SG bring.PRF Aux.PST  
*Each woman<sub>1</sub> brought her<sub>1</sub> son.*
- b. Mutil bakotxe<sub>1</sub> beran<sub>1</sub> amak ekarri ban.  
 his mother.E.SG boy each.A.SG bring.PRF Aux.PST  
*His mother brought each boy.*

As shown in these sentences, a left dislocated object QP can bind a pronoun inside the subject, but a subject QP cannot bind a pronoun inside a left dislocated object.

These data can be summarized as follows:

- (115) Surface order matters for the relative scope of constituents to the left of the verbal complex:
- a. In the SOV order, S outscopes O.

<sup>37</sup>Unless specified otherwise, in the examples considered in this chapter, sentences are to be pronounced with their “neutral” intonation, i.e. with sentence stress on the preverbal constituent. When there is no preverbal constituent, sentence stress is on the verbal complex.

- b. In the OSV order, O outscopes S.

I propose the following account of these facts. First, in Basque, there is no QR; QPs can be interpreted *in situ*.<sup>38</sup> Second, left dislocation does not reconstruct.<sup>39,40</sup>

A different picture emerges when we look at sentences with constituents to the right of the verbal complex:

(116) SVO: S outscopes O

- a. Andra bakotxak<sub>1</sub> ekarri ban beran<sub>1</sub> semi.  
 woman each.E.SG bring.PRF Aux.PST her son.A.SG  
*Each woman<sub>1</sub> brought her<sub>1</sub> son.*
- b. \*Beran<sub>1</sub> amak ekarri ban mutil bakotxe<sub>1</sub>.  
 his mother.E.SG bring.PRF Aux.PST boy each.A.SG  
*His<sub>1</sub> mother brought each boy<sub>1</sub>.*

(117) OVS: S outscopes O

- a. Beran<sub>1</sub> semi ekarri ban andra bakotxak<sub>1</sub>.  
 her son.A.SG bring.PRF Aux.PST woman each.E.SG  
*Each woman<sub>1</sub> brought her<sub>1</sub> son.*
- b. \*Mutil bakotxe<sub>1</sub> ekarri ban beran<sub>1</sub> amak.  
 boy each.A.SG bring.PRF Aux.PST his mother.E.SG  
*His<sub>1</sub> mother brought each boy<sub>1</sub>.*

When one of the constituents is to the right of the verb, word order is not relevant for scope. In both cases, a subject QP can bind a pronoun inside the object, but an object QP cannot bind a pronoun inside the subject.

In §4, it was proposed that constituents to the right of the verbal complex are adjoined to TP as a result of right dislocation:

<sup>38</sup>Alternatively, one could assume that there is QR in Basque, but that it cannot alter scope relations. See, among others, Bruening 2001.

<sup>39</sup>For reasons of time and space, I have simplified greatly the discussion on reconstruction with respect to the Basque data. The reader is referred to Chomsky 1993, Fox 2000, Romero 1997, Sauerland 1998, and references cited there, for discussion.

<sup>40</sup>We could assume an alternative analysis in which QR does apply, and in which the ungrammatical sentences above are explained in terms of Weak Crossover. At this point, I cannot offer arguments for one analysis or the other. However, this does not alter the argument made in this chapter.

- (118) a. [TP [TP ... [<sub>vP</sub> Subject *t* ...] V Aux ...] Object ]  
 b. [TP [TP ... [<sub>vP</sub> *t* Object ...] V Aux ...] Subject ]

Given this structure, the fact that the subject outscopes the object in both cases must mean that right dislocation reconstructs obligatorily.

Further support for this hypothesis comes from sentences in which both the subject and the object are right dislocated:

- (119) VSO order: S outscopes O

- a. Ekarri ban andra bakotxak<sub>1</sub> beran<sub>1</sub> semi.  
 bring.PRF Aux.PST woman each.E.SG her<sub>1</sub> son.A.SG  
*Each woman<sub>1</sub> brought her<sub>1</sub> son.*
- b. \*Ekarri ban beran<sub>1</sub> amak mutil bakotxe<sub>1</sub>.  
 bring.PRF Aux.PST his mother.A.SG boy eachA.SG  
*Her<sub>1</sub> mother brought each son<sub>1</sub>.*

- (120) VOS order: O outscopes S

- a. Ekarri ban beran<sub>1</sub> semi andra bakotxak<sub>1</sub>.  
 bring.PRF Aux.PST her<sub>1</sub> son.A.SG woman each.E.SG  
*Each woman<sub>1</sub> brought her<sub>1</sub> son.*
- b. \*Ekarri ban mutil bakotxe<sub>1</sub> beran<sub>1</sub> amak.  
 bring.PRF Aux.PST boy eachA.SG his mother.A.SG  
*Her<sub>1</sub> mother brought each son<sub>1</sub>.*

Since right dislocated elements reconstruct obligatorily, the judgements are the expected ones: the subject outscopes the object in both the VSO and VOS orders.

Consider, finally, an example with both left and right dislocation. In this case, sentence stress is on the verbal complex (cf. §4.5.3):

- (121) Mutil bakotxe<sub>1</sub> ekarri ban beran<sub>1</sub> amak.  
 boy each.A.SG bring.PRF Aux.PST his mother.E.SG  
*Her<sub>1</sub> mother brought each boy<sub>1</sub>.*

This sentence has the following structure:<sup>41</sup>

<sup>41</sup>A structure in which the object is adjoined higher than the subject is also possible for this sentence. The predictions made for this structure are the same.

(122)

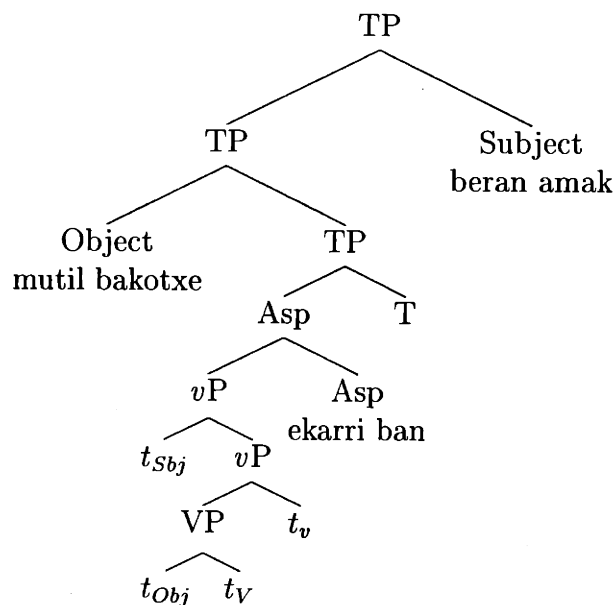

Since, on the surface, both the subject and the object are outside *vP*, the verbal complex receives sentence stress. After reconstruction, the right dislocated subject is interpreted in its base position inside *vP*. Since left dislocation does not reconstruct, the left dislocated object remains in the TP-adjoin position, from which it can bind the the pronoun inside subject, which is inside *vP* after reconstruction.

The data discussed in this section provide strong support for the view of the syntax-phonology interface defended in this thesis. Consider, for instance, the contrast between (117b) and (121). These two sentences have the same word order, OVS. The only difference is that in (117b) sentence stress is on the preverbal object, and in (121) sentence stress is on the verbal complex. Given the structure dependent NSR that was proposed in §§3–4, the prediction is that the object is higher in (121) than in (117b). This prediction is borne out, as witnessed by the fact that the QP object can bind the pronoun in the subject in the former, but not in the latter. If, on the other hand, the NSR were based on linear order (as in the alternative discussed in §4.6.1), these data would not receive a straightforward explanation. One would need to posit principles which would relate prosody, or discourse function, and scope directly. These principles would be needed in addition to the ones that are required to relate syntactic structure and scope. In the present approach, the fact that there is a correlation between the prosodic properties of some constituents and their scope

is analyzed in terms of syntactic structure, so that these additional principles are not necessary.

In the paragraphs above, we have explained several scope facts in terms of left dislocation, right dislocation and their reconstruction properties. Elordieta 2001 (§5), examining very similar data, reaches a very different conclusion. She claims that there is no rightward movement, and that phrases appearing to the right of the verb are the result of leftward movement of the verbal complex. In this section, I argue that, in fact, the data discussed in that work is compatible with an analysis in terms of right dislocation. Furthermore, as I argue below, some of the data we saw above cannot be accounted for in her analysis.

Elordieta provides a number of tests from binding and scope as evidence for her analysis. She concentrates on the following word orders, where ‘V’ stands for the verbal complex:

- (123) a. S IO O V  
 b. S IO V O  
 c. S V IO O  
 d. V S IO O

She provides evidence that, in all these orders, word order correlates with scope, i.e. if  $\alpha$  is to the left of  $\beta$ , then  $\alpha$  outscopes  $\beta$ . This, she claims, is compatible only with an analysis in terms of leftward movement of the verbal complex, but not with an account based on right dislocation.

There is, however, a serious gap in the data considered by Elordieta (2001). Most of the data conforms to one of the word orders in (123). However, all the word orders in (123) preserve the order of arguments in the unmarked clause (i.e. 123a, see §4.2.2). Crucially, none of these include cases in which the object precedes the subject or the indirect object, or cases in which the indirect object precedes the subject. Since, in the analysis defended here, right dislocated phrases reconstruct to their base position, word orders in which the base word order is preserved are irrelevant for deciding between the two analyses. Consider, for instance, the word order in (123d), V-Aux S

IO O. In the analysis defended here, this structure would involve right dislocation of the subject, the indirect object and the direct object. Since all three reconstruct, the prediction is that the scope relations among them are the same as in the base order S IO O V-Aux.

The crucial sentences that show that the analysis defended here is on the right track are the ones involving phrases to the right of the verbal complex which do *not* preserve the base word order, e.g. OVS and VOS. As we saw in the previous section, in these cases, word order is irrelevant for scope. In both cases, the subject outscopes the object.<sup>42</sup> These data cannot be captured in an analysis in terms of leftward movement of the verb, since it predicts that scope always correlates with word order. As shown in the previous section, the relevant generalization concerning phrases appearing to the right of the verbal complex is not that scope relations correlate with word order, but that their scope is the one we would expect if they are interpreted in their base position. To conclude, the variable binding data presented in this section provides further support for right dislocation in Basque, and for the general approach to the syntax of focus defended in this thesis.

### 5.11 Conclusion

In this chapter, I have argued that the Basque preverbal focus position receives a natural explanation in terms of the interaction of the NSR and syntactic movements. The basic principle is that F-marked constituents must contain sentence stress. This approach accounts for all the relevant data, and is able to explain similar facts in Basque and other languages in a unified way. On the other hand, analyses in which F-marked constituents move to [Spec, CP] have been argued to miss important generalizations in accounting for focus projection facts in Basque and other languages. In §5.9, I discussed certain cases of long distance movement which are apparent counterexamples to the analysis defended here. In that section, I proposed an analysis of these structures which is compatible with the approach adopted in this thesis.

---

<sup>42</sup>Except, in the OVS order, when the verbal complex has sentence stress.

Finally, in §5.10 I presented further evidence for the analysis from the scopal properties of left and right dislocation in Basque. In particular, I showed that the differences in the scopal properties of phrases appearing to the right of the verb receive a natural explanation if they are analyzed in terms of rightward movement, but not in terms of leftward movement of the verbal complex. For reasons of time, I have not been able to provide a more complete picture of the scopal and reconstruction properties of Basque movements. This is left as question for future research.



## Chapter 6

### Conclusion

In this thesis, I have proposed a new version of the Nuclear Stress Rule (NSR) which overcomes certain problems found with previous versions. Furthermore, I have also provided an explanation for the so-called preverbal focus position in Basque in terms of the new NSR and prosodic principles imposed on focused phrases.

With respect to the NSR, I have argued that certain generalizations about stress above the word level can be reduced to two basic syntactic properties of phrases: headedness and branchingness. The proposal is based on certain crucial insights found in previous work on the topic (Chomsky, Halle, and Lukoff 1956, Chomsky and Halle 1968, Liberman and Prince 1977, Halle and Vergnaud 1987, Cinque 1993, Zubizarreta 1998). The work reported in this thesis puts these insights together, resulting in a new version of the NSR, within the formalism of the metrical grid, which makes explicit reference to syntactic structure.

With respect to the preverbal focus position in Basque, I have argued, contra much previous work on the topic, that it is not a syntactically defined position. Rather, it is to be explained in terms of certain prosodic conditions imposed on focused phrases. More specifically, focused phrases need to have primary stress in the sentence. The analysis is based on insights about the relation between syntax and discourse found in Cinque 1993, Zubizarreta 1998 and Reinhart 1995. The basic idea is that, given certain independently motivated hypotheses about Basque syntax, the NSR proposed in this thesis predicts that, in many cases, sentence stress is on the preverbal constituent. Since focused phrases need to have sentence stress, it follows that they must be in the preverbal position. However, in certain cases, the analysis

correctly predicts that the focused phrase is not the one preceding the verb, but one containing the verb. I have argued that this provides further evidence in favor of this analysis, and against analyses in which the preverbal focus position is defined syntactically.

## Bibliography

- Abney, Steven P. 1987. The English noun phrase in its sentential aspects. Doctoral Dissertation, Massachusetts Institute of Technology.
- Albizu, Pablo. 1995. Word order in Basque and its implications for the theory of focus. Doctoral Dissertation, Ms., University of Southern California.
- Altube, Sebero. 1929. *Erderismos*. Bilbao: Euskaltzaindia. Reprinted in 1975 by Indauchu Editorial, Bilbao.
- Arregi, Karlos. 1999. Person and number morphology in Basque. In *Papers in morphology and syntax, Cycle two*, ed. Vivian Lin, Cornelia Krause, Benjamin Bruening, and Karlos Arregi, volume 34 of *MIT Working Papers in Linguistics*, 229–264. Cambridge, MA: MITWPL.
- Arregi, Karlos. 2000. Tense in Basque. Ms., Massachusetts Institute of Technology. Available at <http://mit.edu/karlos/www>.
- Arregi, Karlos. 2001a. The *have/be* alternation in Basque. Ms., Massachusetts Institute of Technology. Available at <http://mit.edu/karlos/www>.
- Arregi, Karlos. 2001b. Focus and word order in Basque. Ms., Massachusetts Institute of Technology. Available at <http://mit.edu/karlos/www>.
- Arregi, Karlos, and Isabel Oltra-Massuet. 2001. Stress-by-structure in Spanish. Ms., Massachusetts Institute of Technology and Universitat Rovira i Virgili. Available at <http://mit.edu/karlos/www>. Revised version to appear in *Linguistic Inquiry*.
- Artiagoitia, Xabier. 1997. DP predicates in Basque. *University of Washington Working Papers in Linguistics* 15:161–198.
- Azkarate, Miren, David Farwell, Jon Ortiz de Urbina, and Mario Saltarelli. 1982. Word order and *wh*-movement in Basque. In *Proceedings of the North East Linguistic Society 12*, ed. James Pustejovsky and Peter Sells, 36–48. Amherst: GLSA Publications.
- Bobaljik, Jonathan D. 1996. What does adjacency do? Ms., Harvard University. Available at <http://www.arts.mcgill.ca/programs/linguistics/faculty/bobaljik>.
- Bolinger, Dwight. 1965. *Forms of English: Accent, morpheme, order*. Cambridge, MA: Harvard University Press. Edited by Isamu Abe and Tetsuya Kanekiyo.
- Bruening, Benjamin. 2001. QR obeys superiority: Frozen scope and ACD. *Linguistic Inquiry* 32:233–273.
- Büring, Daniel. 1997. *The meaning of topic and focus: the 59th Street bridge accent*. New York: Routledge.
- Chomsky, Noam. 1971. Deep structure, surface structure and semantic interpretation. In *Semantics: An interdisciplinary reader in philosophy, linguistics, and psychology*, ed. Daniel Steinberg and Leon Jacobovits, 183–216. Cambridge University

- Press.
- Chomsky, Noam. 1976. Conditions on rules of grammar. *Linguistic Analysis* 2:303–351.
- Chomsky, Noam. 1993. A minimalist program for linguistic theory. In *The view from Building 20: Essays in honor of Sylvain Bromberger*, ed. Kenneth Hale and Samuel Jay Keyser, 1–52. Cambridge, MA: MIT Press.
- Chomsky, Noam. 1995. *The Minimalist Program*. Cambridge, MA: MIT Press.
- Chomsky, Noam. 2000. Minimalist inquiries: The framework. In *Step by step: Essays on minimalist syntax in honor of Howard Lasnik*, ed. Roger Martin, David Michaels, and Juan Uriagereka, 89–155. Cambridge, MA: MIT Press.
- Chomsky, Noam. 2001. Derivation by phase. In *Ken Hale: A life in language*, ed. Michael Kenstowicz, 1–52. Cambridge, MA: MIT Press.
- Chomsky, Noam, and Morris Halle. 1968. *The sound pattern of English*. New York: Harper and Row.
- Chomsky, Noam, Morris Halle, and Fred Lukoff. 1956. On accent and juncture in English. In *For Roman Jakobson*, ed. Morris Halle, Horace Lunt, Hugh MacLean, and Cornelis H. van Schooneveld, 65–80. The Hague: Mouton.
- Cinque, Guglielmo. 1993. A null theory of phrase and compound stress. *Linguistic Inquiry* 24:239–297.
- Cinque, Guglielmo. 1994. On the evidence for partial N-movement in the Romance DP. In *Paths towards universal grammar: Studies in honor of Richard S. Kayne*, ed. Guglielmo Cinque, Jan Koster, Jean-Yves Pollock, Luigi Rizzi, and Raffaella Zanuttini, 85–110. Washington, DC: Georgetown University Press.
- Costa, João. 1998. Word order variation: A constraint-based approach. Doctoral Dissertation, Holland Institute of Generative Linguistics/Leiden University.
- de Rijk, Rudolphus P. G. 1970. Vowel interactions in Bizcayan Basque. *Fontes Linguae Vasconum* 2:149–167.
- de Rijk, Rudolphus P. G. 1978. Topic fronting, focus positioning, and the nature of the verb phrase in Basque. In *Studies on fronting*, ed. Frank Jansen, 81–112. Lille: Peter de Ridder Press.
- Dell, François. 1984. L'Accentuation dans les phrases en français. In *Forme sonore du langage*, ed. François Dell, Daniel Hirst, and Jean-Roger Vergnaud, 65–122. Paris: Hermann.
- Den Besten, Hans. 1977. On the interaction of root transformations and lexical deletive rules. Ms., Massachusetts Institute of Technology.
- Drubig, Hans B. 1994. Island constraints and the syntactic nature of focus and association with focus. *Arbeitspapiere des SFB 340* 51. Universität Tübingen.
- Eguskitza, Andolin. 1986. Topics in the syntax of Basque and Romance. Doctoral Dissertation, University of California, Los Angeles.
- Elordieta, Arantzazu. 2001. Verb movement and constituent permutation in Basque. Doctoral Dissertation, Holland Institute of Generative Linguistics/Leiden University.
- Elordieta, Gorka. 1997a. Accent, tone and intonation in Lekeitio Basque. In *Issues in the phonology and morphology of the major Iberian languages*, ed. Fernando Martínez-Gil and Alfonso Morales-Front, 3–78. Washington, DC: Georgetown Uni-

- versity Press.
- Elordieta, Gorka. 1997b. Morphosyntactic feature chains and phonological domains. Doctoral Dissertation, University of Southern California.
- Embick, David, and Rolf Noyer. 2001. Movement operations after syntax. *Linguistic Inquiry* 32:555–595.
- Emonds, Joseph. 1976. *A transformational approach to English syntax*. New York: Academic Press.
- Emonds, Joseph. 1985. *A unified theory of syntactic categories*. Dordrecht: Foris.
- Fox, Danny. 2000. *Economy and semantic interpretation*. Cambridge, MA: MIT Press and MIT Working Papers in Linguistics.
- Gussenhoven, Carlos. 1984. *On the grammar and semantics of sentence accents*. Dordrecht: Foris.
- Hale, Kenneth, and Samuel Jay Keyser. 1993. On argument structure and the lexical expression of syntactic relations. In *The view from Building 20: Essays in honor of Sylvain Bromberger*, ed. Kenneth Hale and Samuel Jay Keyser, 53–109. Cambridge, Mass.: MIT Press.
- Halle, Morris. 1998. The stress of English words 1968–1998. *Linguistic Inquiry* 29:539–568.
- Halle, Morris, and William J. Idsardi. 1995. General properties of stress and metrical structure. In *The handbook of phonological theory*, ed. John A. Goldsmith, 403–443. Cambridge, MA: Blackwell.
- Halle, Morris, and Alec Marantz. 1993. Distributed Morphology and the pieces of inflection. In *The view from Building 20: Essays in honor of Sylvain Bromberger*, ed. Kenneth Hale and Samuel Jay Keyser, 111–176. Cambridge, MA: MIT Press.
- Halle, Morris, and Jean-Roger Vergnaud. 1987. *An essay on stress*. Cambridge, MA: MIT Press.
- Hamblin, Charles L. 1973. Questions in Montague English. *Foundations of Language* 10:41–53.
- Haraguchi, Shosuke. 1977. *The tone pattern of Japanese: An autosegmental theory of tonology*. Tokyo: Kaitakusha.
- Harris, James W. 1995. Projection and edge marking in the computation of stress in Spanish. In *The handbook of phonological theory*, ed. John A. Goldsmith, 867–887. Cambridge, MA: Blackwell.
- Hayes, Bruce. 1995. *Metrical stress theory*. Chicago: University of Chicago Press.
- Hualde, José Ignacio. 1991a. *Basque phonology*. New York: Routledge.
- Hualde, José Ignacio. 1991b. A metrical analysis of western Basque pitch accent. Ms., University of Illinois.
- Hualde, José Ignacio. 1991c. Underspecified and unmarked vowels. *Linguistic Inquiry* 22:205–209.
- Hualde, José Ignacio. 1995. Análisis del sistema acentual de Ondarra. *Anuario del Seminario de filología vasca "Julio de Urquijo": International Journal of Basque Linguistics and Philology* 29:319–343.
- Hualde, José Ignacio. 1996. Accentuation and empty vowels in Ondarra Basque: Against the concept of phonological derivation. *Lingua* 99:197–206.
- Hualde, José Ignacio. 1997. *Euskararen azentuerak*. Bilbao: Euskal Herriko Unibert-

- sitatea.
- Hualde, José Ignacio. 1999a. Basque accentuation. In *Word prosodic systems in the languages of Europe*, ed. Harry van der Hulst, 947–993. Mouton de Gruyter.
- Hualde, José Ignacio. 1999b. Vowel interaction and related phenomena in Basque and the nature of morphophonological knowledge. *Cognitive Linguistics* 10:33–56.
- Hualde, José Ignacio. 2000. On system-driven sound change: Accent shift in Markina Basque. *Lingua* 110:99–129.
- Hualde, José Ignacio, and Xabier Bilbao. 1993. The prosodic system of the Basque dialect of Getxo: A metrical analysis. *Linguistics* 31:59–85.
- Hualde, José Ignacio, Gorka Elordieta, and Arantzazu Elordieta. 1994. *The Basque dialect of Lekeitio*. Bilbao: Euskal Herriko Unibertsitatea.
- Huang, C.-T. James. 1982. Logical relations in Chinese and the theory of grammar. Doctoral Dissertation, Massachusetts Institute of Technology.
- Idsardi, William J. 1992. The computation of stress. Doctoral Dissertation, Massachusetts Institute of Technology.
- Idsardi, William J., and Thomas C. Purnell. 1997. Metrical tone and the elsewhere condition. *Rivista di Linguistica* 9:1–28.
- Ishihara, Shinichiro. 2001. Stress, focus and scrambling in Japanese. In *A few from Building E39: Papers in syntax, semantics and their interface*, ed. Elena Guerzoni and Ora Matushansky, volume 39 of *MIT Working Papers in Linguistics*, 142–175. Cambridge, MA: MITWPL.
- Jackendoff, Ray S. 1972. *Semantic interpretation in Generative Grammar*. Cambridge, MA: MIT Press.
- Kayne, Richard S. 1994. *The antisymmetry of syntax*. Cambridge, MA: MIT Press.
- Krifka, Manfred. 1996. Frameworks for the representation focus. In *Proceedings of the Conference on Formal Grammar, Eighth European Summer School on Logic, Language and Information*, ed. G. Kruijff, G. Morrill, and D. Oehrle. Prague.
- Laka, Itziar. 1990. Negation in syntax: On the nature of functional categories and projections. Doctoral Dissertation, Massachusetts Institute of Technology. Revised version published as Laka 1994.
- Laka, Itziar. 1994. *On the syntax of negation*. New York: Garland.
- Laka, Itziar. 1996. A brief grammar of Euskara, the Basque language. Ms., University of the Basque Country. Available at <http://www.ehu.es/grammar/index.htm>.
- Laka, Itziar, and Juan Uriagereka. 1987. Barriers for Basque and vice-versa. In *Proceedings of the North East Linguistic Society 17*, ed. Joyce McDonough and Bernadette Plunkett. Amherst: GLSA Publications.
- Larson, Richard K. 1988. On the double object construction. *Linguistic Inquiry* 19:335–391.
- Lieberman, Mark Y. 1975. The intonational system of English. Doctoral Dissertation, Massachusetts Institute of Technology. Revised version published as Liberman 1979.
- Lieberman, Mark Y. 1979. *The intonational system of English*. New York: Garland.
- Lieberman, Mark Y., and Janet B. Pierrehumbert. 1984. Intonational invariance under changes in pitch range and length. In *Language sound structure*, ed. Mark Aronoff and Richard T. Oehrle, 157–233. Cambridge, MA: MIT Press.

- Liberman, Mark Y., and Allan S. Prince. 1977. On stress and linguistic rhythm. *Linguistic Inquiry* 8:249–336.
- Longobardi, Giuseppe. 1991. Extraction from NP and the proper notion of head government. In *The syntax of noun phrases: Configuration, parameters, and empty categories*, ed. Alessandra Girogi and Giuseppe Longobardi, 57–112. Cambridge: Cambridge University Press.
- Longobardi, Giuseppe. 1994. Reference and proper names: A theory of N-movement in syntax and Logical Form. *Linguistic Inquiry* 25:609–665.
- Marantz, Alec. 1988. Clitics, morphological merger, and the mapping to phonological structure. In *Theoretical morphology: Approaches in modern linguistics*, ed. Michael Hammond and Michael Noonan, 253–270. San Diego: Academic Press.
- Marantz, Alec. 1993. Implications of asymmetries in double object constructions. In *Theoretical aspects of Bantu grammar*, ed. Sam Mchombo. Stanford: CSLI.
- Marantz, Alec. 1997. No escape from syntax: Don't try morphological analysis in the privacy of your own lexicon. In *Proceedings of the 21st Annual Penn Linguistics Colloquium*, ed. Alexis Dimitriadis, Laura Siegel, Clarissa Surek-Clark, and Alexander Williams, volume 4.2 of *U. Penn Working Papers in Linguistics*, 201–225. Philadelphia: Penn Linguistics Club.
- McCawley, James D. 1968. The accentual system of Standard Japanese. Doctoral Dissertation, Massachusetts Institute of Technology.
- Mitxelena, Koldo. 1981. Galdegaia eta mintzagaia euskaraz. In *Euskal linguistika eta literatura: bide berriak*, ed. Antonio Tovar, 57–81. Bilbao: Deustuko Unibertsitatea.
- Neeleman, Ad, and Tanya Reinhart. 1998. Scrambling and the PF interface. In *The projection of arguments: Lexical and compositional factors*, ed. Miriam Butt and Wilhelm Geuder, 309–353. Stanford: CSLI.
- Ortiz de Urbina, Jon. 1983. Empty categories and focus in Basque. *Studies in the Linguistic Sciences* 13:133–156.
- Ortiz de Urbina, Jon. 1986. Some parameters in the grammar of Basque. Doctoral Dissertation, University of Illinois at Urbana-Champaign. Revised version published as Ortiz de Urbina 1989.
- Ortiz de Urbina, Jon. 1989. *Parameters in the grammar of Basque: A GB approach to Basque syntax*. Dordrecht: Foris.
- Ortiz de Urbina, Jon. 1994. Verb-initial patterns in Basque and Breton. *Lingua* 94:125–153.
- Ortiz de Urbina, Jon. 1995. Residual verb second and verb first in Basque. In *Discourse configurational languages*, ed. Katalin É. Kiss, 99–121. New York: Oxford University Press.
- Pesetsky, David. 1994. *Zero syntax: Experiencers and cascades*. Cambridge, MA: MIT Press.
- Pierrehumbert, Janet B. 1980. The phonology and phonetics of English intonation. Doctoral Dissertation, Massachusetts Institute of Technology.
- Prince, Alan S. 1983. Relating to the grid. *Linguistic Inquiry* 14:19–100.
- Purnell, Thomas C. 1997. Principles and parameters of phonological rules: Evidence from tone languages. Doctoral Dissertation, University of Delaware.
- Pylkkänen, Liina. 2002. Introducing arguments. Doctoral Dissertation, Massachusetts

- Institute of Technology.
- Reinhart, Tanya. 1994. *Wh*-in-situ in the framework of the minimalist program. *UiL OTS Working Papers of Theoretical Linguistics* 94-003. Utrecht Institute of Linguistics. Revised version published as Reinhart 1998.
- Reinhart, Tanya. 1995. Interface strategies. *UiL OTS Working Papers of Theoretical Linguistics* 95-002. Utrecht Institute of Linguistics.
- Reinhart, Tanya. 1998. *Wh*-in-situ in the framework of the minimalist program. *Natural Language Semantics* 6:29–56.
- Ritter, Elizabeth. 1993. Where's gender? *Linguistic Inquiry* 24:795–903.
- Rizzi, Luigi. 1991. Residual verb movement and the *wh*-criterion. Ms., Univeristé de Genève.
- Roca, Iggy. 1988. Theoretical implications of Spanish word stress. *Linguistic Inquiry* 19:393–423.
- Roca, Iggy. 1997. On the role of accent in stress systems: Spanish evidence. In *Issues in the phonology and morphology of the major Iberian languages*, ed. Fernando Martínez-Gil and Alfonso Morales-Front, 619–664. Washington, DC: Georgetown University Press.
- Rochemont, Michael. 1986. *Focus in Generative Grammar*. Philadelphia: John Benjamins.
- Romero, Maribel. 1997. The correlation between scope reconstruction and connectivity effects. In *Proceedings of the XVI West Coast Conference in Formal Linguistics*, ed. Emily Curtis, James Lyle, and Gabriel Webster, 351–365. Stanford: CSLI Publications.
- Rooth, Mats. 1985. Association with focus. Doctoral Dissertation, University of Massachusetts, Amherst.
- Rooth, Mats. 1996. Focus. In *The handbook of contemporary semantic theory*, ed. Shalom Lappin, 271–297. Oxford: Blackwell.
- Rullmann, Hotze, and Sigrid Beck. 1998. Reconstruction and the interpretation of which-phrases. In *Reconstruction: Proceedings of the 1997 Tübingen Workshop*, ed. Graham Katz, Shin-Sook Kim, and Heike Winhart, 223–256. Universität Stuttgart and Universität Tübingen.
- Saltarelli, Mario. 1988. *Basque*. London: Croom Helm.
- Sauerland, Uli. 1998. The meaning of chains. Doctoral Dissertation, Massachusetts Institute of Technology.
- Schmerling, Susan F. 1976. *Aspects of English sentence stress*. Austin: University of Texas Press.
- Schwarzschild, Roger. 1999. GIVENness, AVOIDF and other constraints on the placement of accent. *Natural Language Semantics* 7:141–177.
- Selkirk, Elisabeth. 1984. *Phonology and syntax: The relation between sound and structure*. Cambridge, MA: MIT Press.
- Selkirk, Elisabeth. 1995. Sentence prosody: Intonation, stress, and phrasing. In *The handbook of phonological theory*, ed. John A. Goldsmith, 550–569. Cambridge, MA: Blackwell.
- Szendrői, Kriszta. 2001. Focus and the syntax-phonology interface. Doctoral Dissertation, Univeristy College London.

- Tenny, Carol L. 1986. Tone and cyclicity in Tokyo Japanese. Ms., Massachusetts Institute of Technology.
- Truckenbrodt, Hubert. 1995. Phonological phrases: Their relation to syntax, focus and prominence. Doctoral Dissertation, Massachusetts Institute of Technology.
- Uriagereka, Juan. 1992. The syntax of movement in Basque. In *Syntactic theory and Basque Syntax*, ed. Jon Ortiz de Urbina and Joseba Andoni Lakarra, 417–445. Bilbao: Euskal Herriko Unibertsitatea.
- Uriagereka, Juan. 1999. Minimal restrictions on Basque movements. *Natural Language and Linguistic Theory* 17:403–444.
- Vallduví, Enric. 1992. *The informational component*. New York: Garland.
- Vallduví, Enric. 1995. Structural properties of information packaging in Catalan. In *Discourse configurational languages*, ed. Katalin É. Kiss, 122–152. New York: Oxford University Press.
- Watanabe, Akira. 1991. Some problems in Tokyo Japanese accentuation: A study of the notions of “stem” and “affix”. Ms., Massachusetts Institute of Technology.
- Williams, Edwin. 1982. Another argument that passive is transformational. *Linguistic Inquiry* 12:160–163.
- Zubizarreta, María Luisa. 1998. *Prosody, focus, and word order*. Cambridge, MA: MIT Press.
- Zwarts, Frans. 1973. On restricting base structure recursion in Dutch. Ms., University of Amsterdam.