



Integrated Concurrent Engineering (ICE): Building Lean Conceptual Design Factories

Thomas Coffee

The ICE Approach





Results of the ICE Approach

- **Cost** reductions ($> 3\times$) in individual concept design studies
- **Schedule** reductions ($> 10\times$) in individual concept design studies
- **Volume** increases ($> 5\times$) in number of studies over a given period
- **Quality** cost estimates ($\pm 5-10\%$) versus state-of-the-art



Standardizing Design Relationships

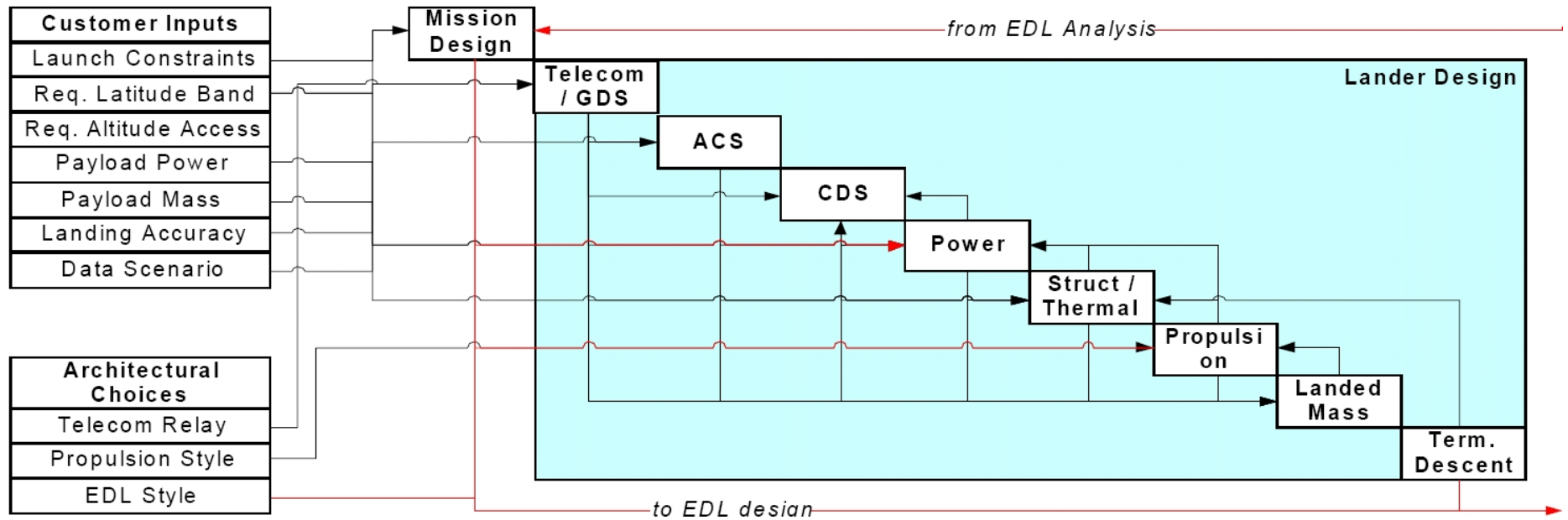

(Lamassoure, 2004)

Building a Process Environment

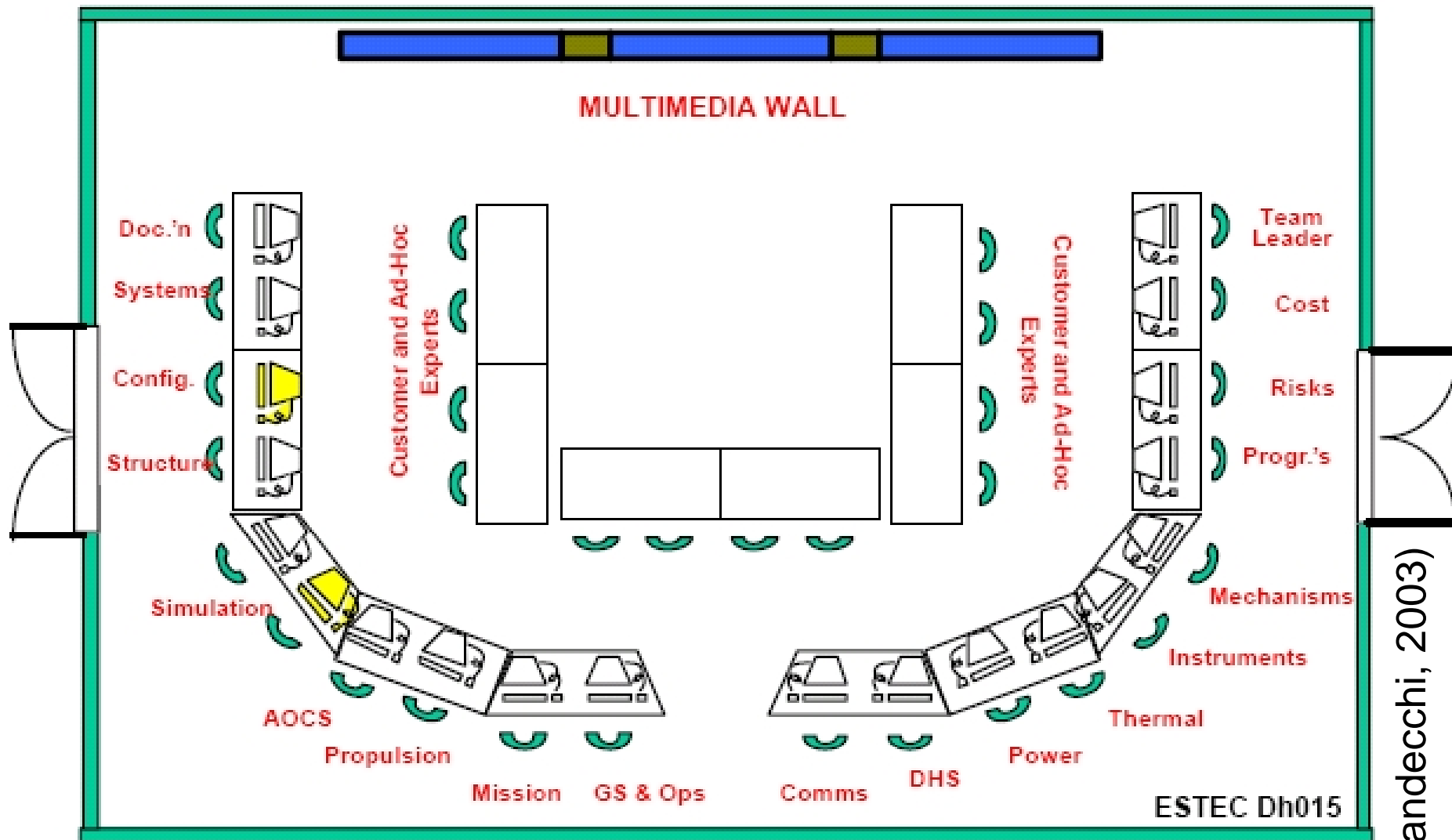

(Bandecchi, 2003)



Building Standardized Yet Flexible Tools

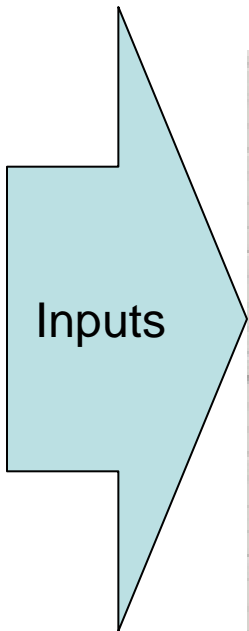

ADACS Update

Inputs	Current	Previous
Spacecraft On-Orbit Mass [kg]	34.9	34.9
Roll Spacecraft Inertia [kg-m ²]	19.9	19.9
Pitch Spacecraft Inertia [kg-m ²]	41.9	41.9
Yaw Spacecraft Inertia [kg-m ²]	27.4	27.4
Number of Solar Array Panels	3.8	3.8
Power Mode 1	Daylight	Daylight
Power Mode 2	Eclipse	Eclipse
Power Mode 3	Mode 3	Mode 3
Power Mode 4	Mode 4	Mode 4
Power Mode 5	Mode 5	Mode 5
Power Mode 6	Mode 6	Mode 6
Mission Life [yrs]	3.3	3.3

Legend:
■ Variables
■ Database Linked Parameters
■ Inputs from other Modules
■ Computed Values

Buttons: Go To Main Menu, Go To Design Tooltips

ADACS Requirements

Requirements	Value	Notes
Attitude Knowledge	0.0000 [deg]	
Pointing Accuracy	0.0000 [mrad]	
Max Slow Angle	180.0000 [deg]	For assumed acceleration profile, refer to the figure
Max Slow Rate	0.10000 [deg/sec]	
Max Slow Acceleration	0.00000 [deg/sec ²]	Good value unless input is known
Max Slow Jerk	0.00000 [deg/sec ³]	Good value unless input is known
Min Slow Time	1000.0 [sec]	Computed based on Min Time slow theory
Average Slow Rate	0.1 [deg/sec]	

For no slow, use very small value

ADACS	Unit	Mars		Planet [m]						NASA TDR
		[kg]	[kg]	Daylight	Eclipse	Mode 3	Mode 4	Mode 5	Mode 6	
Number of ADACS Thrusters	0									
Minimum Thrust Level [N]	1.0									
Total Accumulated Delta-V [km/s]	300.0									
Number of Command & Telemetry	2.0									
Fine Sun Sensor	2	0.63	1.4	2.86	0.00	0.0	0.0	0.0	0.0	0
Coarse Sun Sensor	0	0.0	0.0	0.00	0.00	0.0	0.0	0.0	0.0	0

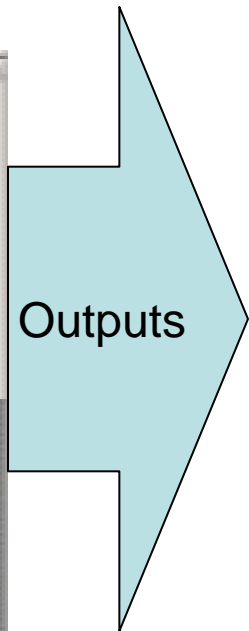

(McInnes, 2003)



The Role of the Customer

Pareto front of "best" architectures

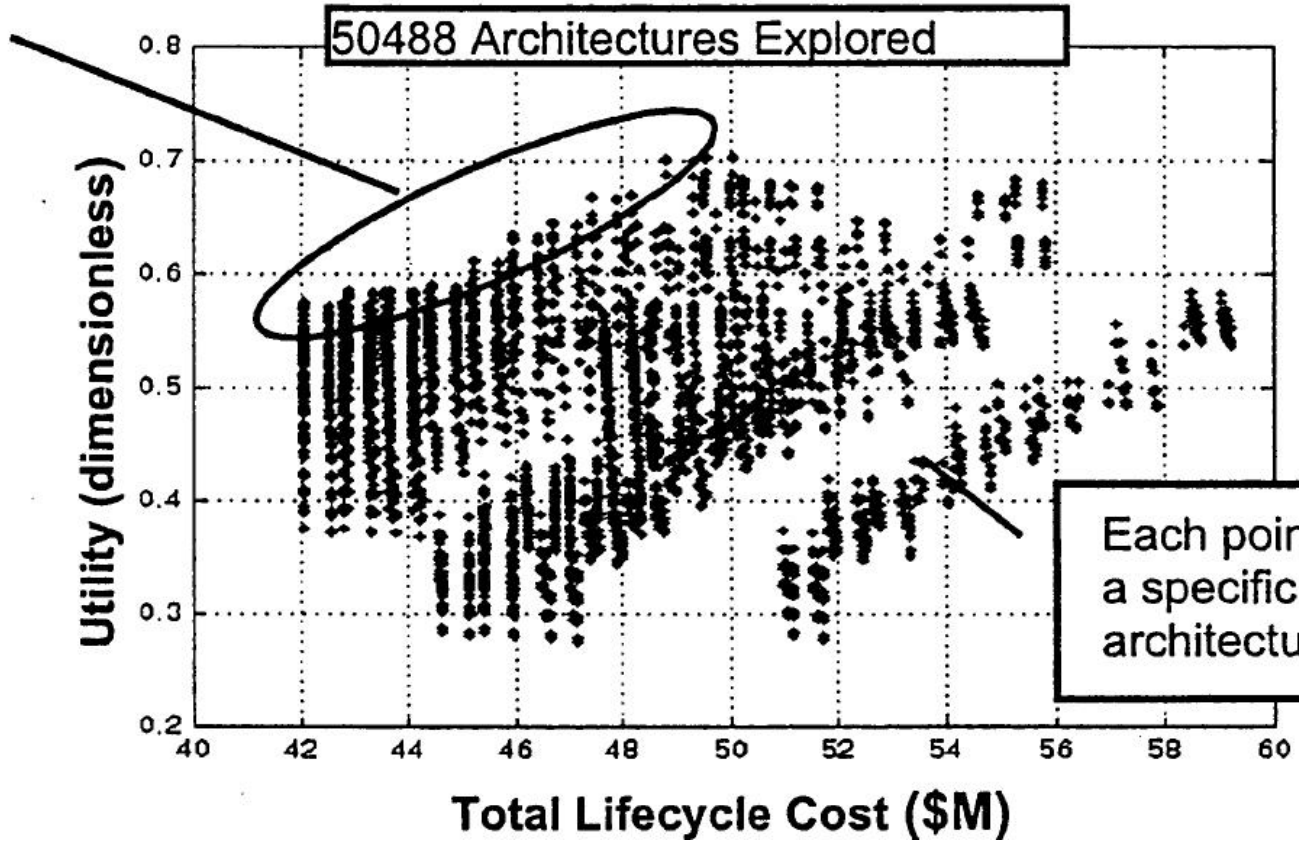

(McManus, 2004)



How Far Can We Go with ICE?

- **Flexibility/Reconfigurability:** functional decomposition and manipulation of design models
- **High- & Low-Level Integration:** end-to-end models for simultaneous conceptual and detailed design
- **Solution Space Search:** practical reuse of design solutions from prior internal or public projects
- **Simulated Collocation:** distributed collaborative design with low communication barriers
- **Organizational Integration:** universal process adoption and training within the enterprise

In information production, there is no limit to how far we can go ...