

DETERMINATION OF THE OPTIMUM
RESOLUTION ELEMENT FOR A
PILOT WARNING INDICATOR

by

THOMAS BASIL SMITH, III
S.B., Massachusetts Institute of Technology
(1969)

SUBMITTED IN PARTIAL FULFILLMENT
OF THE REQUIREMENTS FOR THE
DEGREE OF MASTER OF SCIENCE

at the
MASSACHUSETTS INSTITUTE OF TECHNOLOGY
June 1970

Signature of Author

Department of Aeronautics
and Astronautics, June 1970

Certified by

Thesis Supervisor

Accepted by

Chairman, Departmental
Graduate Committee

DETERMINATION OF THE OPTIMUM
RESOLUTION ELEMENT FOR A
PILOT WARNING INDICATOR

by

Thomas Basil Smith, III

Submitted to the Department of Aeronautics and
Astronautics, Massachusetts Institute of Technology, on
June 4, 1970, in partial fulfillment of the requirements
for the degree of Master of Science.

ABSTRACT

There is a need for a low cost pilot warning indicator for general aviation aircraft. This device, as currently proposed, would involve a xenon strobe mounted on all planes and a sensor element mounted on planes desiring the PWI capabilities. The PWI device would, on detection of a nearby aircraft, warn the pilot of the danger and assist him in locating the threatening aircraft.

Experiments were performed in order to determine how accurately the PWI device need establish the direction of an incoming threatening aircraft. It is important that pilot response be as rapid as possible but, at the same time, the cost of the warning device must be kept low. Because of this, a PWI resolution was sought such that near optimum pilot performance could be expected and such that no excessive resolution need be purchased.

Examination of the data revealed that a resolution element of about $11^\circ \times 11^\circ$ is optimal for a low cost device. Resolution of about $6^\circ \times 6^\circ$ gives somewhat better pilot performance, but the increased cost of instrumenting this reduced sector size was not justified by the slight increases in pilot performance.

Thesis Supervisor: Renwick E. Curry
Title: Assistant Professor of
Aeronautics and Astronautics

ACKNOWLEDGEMENTS

The author wishes to thank Professors Renwick E. Curry and Laurence R. Young, and Mr. George Economou for their guidance and suggestions in preparation of this experiment.

Special thanks are offered to Dr. Ann Story for her interest and advice on psychological aspects of this project and to Chuck Oman for his instruction on the hybrid computer.

Mr. Roger Marian also assisted in the construction of the test equipment.

This research was sponsored under NASA-ERC grant NGR-22-009-444.

TABLE OF CONTENTS

<u>Chapter</u>	<u>Title</u>	<u>Page</u>
1	INTRODUCTION	1
2	EQUIPMENT	
	2.1 Wide Angle Screen	7
	2.2 Background Projector	10
	2.3 Target Projector	10
	2.4 Turntable	12
	2.5 Hybrid Computer	12
3	EXPERIMENTAL DESIGN AND PROCEDURES	14
4	SUMMARY OF DATA	
	4.1 General Form Used in Data Presentation	22
	4.2 Tables of Results	26
	4.3 Evaluation of Secondary Task	53
5	DISCUSSION OF RESULTS	
	5.1 Comparison of Subject Performance Under Differing Backgrounds	54
	5.2 Effect of Target Conspicuousness on Optimum Sector Selection	55
	5.3 Analysis of Effect of Sector Size on Search Time	56

TABLE OF CONTENTS (Cont.)

5	DISCUSSION OF RESULTS (Cont.)	
	5.4 Central Vision Versus Peripheral Vision in a Search Situation	58
	5.5 Realistic PWI Devices	60
6	CONCLUSIONS	62
Appendix		
I	Instructions to Subjects	65
II	PDP-8 Computer Program	69
III	GPS 290T Wiring Program	103
	References	106

CHAPTER 1

INTRODUCTION

Most general aviation aircraft operate in the relatively crowded airspace of less than 10,000 feet. Many of these aircraft fly out of uncontrolled airfields and maintain minimum contact with air traffic control. Unlike commercial aviation or military aircraft, general aviation relies almost exclusively on the "see and be seen" principle to avoid mid-air collisions. That is, collisions are prevented merely by constant vigilance on the part of the pilot. One need only look at the alarming statistics on the number of mid-air collisions and the even greater number of near misses to recognize that this system is not satisfactory. The era in which such a simplistic approach was accepted is coming to a close. The higher speeds and the ever increasing density of aviation today call for a more reliable system.

Commercial and military aircraft planners have long recognized this problem. Elaborate collision avoidance aids have and are being developed for these craft. Unfortunately, these devices cost many thousands of dollars. In fact,

the cost of current electronic collision avoidance devices is several times the purchase price of many small aircraft. It is hard to imagine installing these expensive aids on the typical small plane.

The pilot warning indicator is an attempt to find a compromise solution. Principally, this device would warn the pilot of possible collision threats and hopefully provide him with sufficient time and information to sight the threatening aircraft and take appropriate measures. It is hoped that, by sacrificing certain elaborate features of the existing collision avoidance devices, an acceptable, worthwhile and reasonably priced warning mechanism might be developed.

This economy represents several noteworthy reductions in performance. First, the PWI will not aid the pilot in selecting an effective evasive maneuver. The probability of a pilot error leading to a collision is therefore greater with the PWI than with the elaborate collision avoidance devices. Secondly, it will present the pilot with a significant number of false alarms, possibly as many as seven false alarms for every real one. Because of this, the pilot may develop a tendency to ignore warnings. The last and most serious flaw of the PWI device is that, in

certain cases, it may in fact fail to give any warning of an approaching aircraft. The optical sensor is sensitive only in regions of likely threats. If an aircraft approaches from an unlikely angle, for example, from above, the PWI device may give no warning.

Despite these shortcomings, PWI offers an opportunity for increased safety since it supplements pilot senses so as to overcome basic weaknesses. A pilot of a general aviation aircraft seems to be poorly adapted to the task of maintaining constant and vigilant scanning of the sky for incoming planes. PWI will help him in this searching task and can reliably detect an approaching aircraft before it is even visible to the pilot. The sky is broken down into several sensitive regions or sectors. When the flashes from the strobe of a nearby plane are detected within a sector, an alarm is sounded and information indicating which sector originated the alarm is passed to the pilot. He can then scan the sky corresponding to the alarm sector. If this sector is sufficiently small, it is reasonable to expect that the pilot will more easily be able to locate the plane. Naturally, the design of the PWI should attempt to optimize the performance of the PWI/pilot system so as to achieve a maximum safety level.

PWI takes a task which was entirely in the domain of the pilot and breaks it into two parts. The first portion, initial detection of the plane, is assumed by the instrumentation and PWI hardware. Extensive hardware studies have been performed¹ or are currently in progress on various PWI systems. In general, they tend to confirm the soundness of the beacon-sensor concept for PWI. The second portion, final search, sighting and avoidance, remains with the pilot. Good pilot performance in his task requires a smooth interface between the instrument and the pilot. This interface is some kind of warning display. Work on various types of heads up and audio displays is being done in conjunction with this study at the Man-Vehicle Lab. In addition, some preliminary work on PWI displays was done at Dunlap and Associates²¹ and by Charles Burr, again at the Man-Vehicle Lab. These studies have been primarily concerned with a comparison of the effectiveness of differing displays under similar PWI conditions.

Essentially, this instrument should not attempt to develop and relay uselessly detailed instructions as to target position in the sky. If the pilot can only effectively utilize a limited degree of resolution, an attempt to relay more detail is wasteful. First, it adds to the cost of the device without any benefit. Secondly, the added time spent by the pilot in analyzing the more detailed information may degrade his performance.

This study more closely analyzes the role of the pilot in a PWI system. The work done by John Volkmann²² is suggestive of the problem which was investigated. Volkmann observed that, with relatively small search fields, the search time is reasonably short. Search performance is only slightly degraded as the field of search grows larger. This trend seems to break down sharply at some critical field size and further increases in size bring sharp drops in search effectiveness. This work suggests that the same factor may effect PWI implementation. If this is the case, PWI devices should strive to have a resolution segment of about the same size as this critical element. Increasing resolution could not be expected to substantially reduce search time. A decrease in resolution would result in heavy penalties because the pilot's search would become markedly less efficient. Naturally, if such an optimum size existed in the PWI situation, the critical sized sector might be expected to be a vague function of the varied out the window fields of view available from a cockpit.

The purpose of this study is to investigate the relationship between instrument resolution and the pilot's efficiency in locating the target. It was hypothesized that an optimum sized resolution element or sector might be found so as to guide the development of the actual PWI device. It was, of course, hoped that under most conditions

the optimum sector size or area to be searched would not be the trivial solution, the smaller the better. The following factors were investigated:

(1) Time to locate a threatening target against a cluttered background. The variables were:

- (a) Contrast between target and background
- (b) Sector size to be searched

(2) Time to locate a threatening target against a relatively less cluttered background. The variables were:

- (a) Contrast between background and target
- (b) Sector size to be searched

All tests were conducted using a screen which covered $\pm 80^\circ$ in azimuth (0° straight ahead) and $\pm 25^\circ$ in elevation. No attempt was made to reproduce aircraft out the window scenes with any visual fidelity. Instead, a controlled background was created which was uniform in brightness and visual clutter over the entire screen. This allowed the establishment of reproducibly baseline data which might then be extrapolated to influence the design of an actual flight instrument.

CHAPTER 2

EQUIPMENT

The test equipment consisted of the following major items.

- (1) Wide angle screen
- (2) Three Kodak 600 slide projectors
- (3) One Kodak 750 slide projector
- (4) Turntable with associated drive equipment
- (5) Hybrid computer; PDP-8/GPS 290T digital analog computer

Figure 2.1 shows the basic experimental arrangement of this equipment.

2.1 Wide Angle Screen

A wide angle circular screen was constructed from two 4'X8' masonite panels. The radius of curvature was roughly 4.75 feet. The center of the screen was about 4 feet from the floor. From the subject's point of view, the screen covered about 160° horizontally and about 40° vertically. The screen was painted white with a rough matte finish. Figures 2.2 and 2.3 show the screen and the subjects location relative to it.

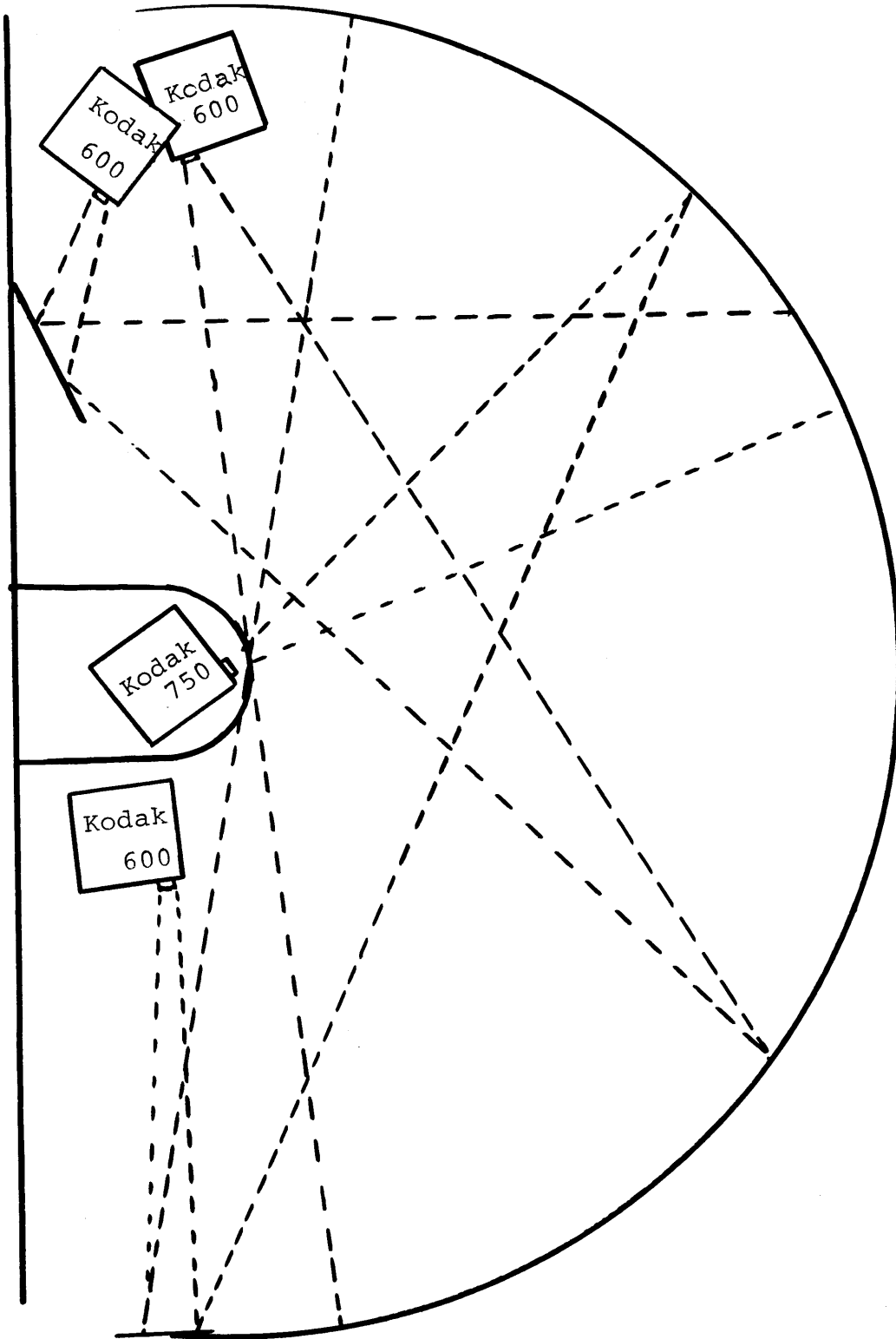

Figure 2.1: Basic Layout of Projectors and Screen.

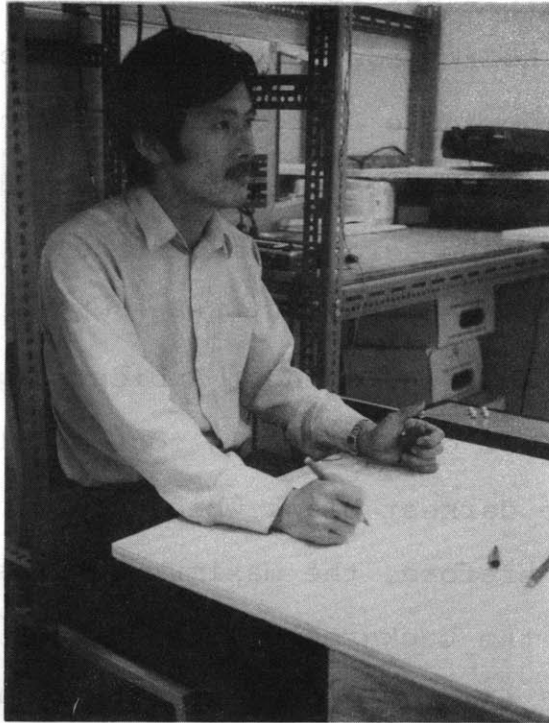

Figure 2.2 Subject in Position

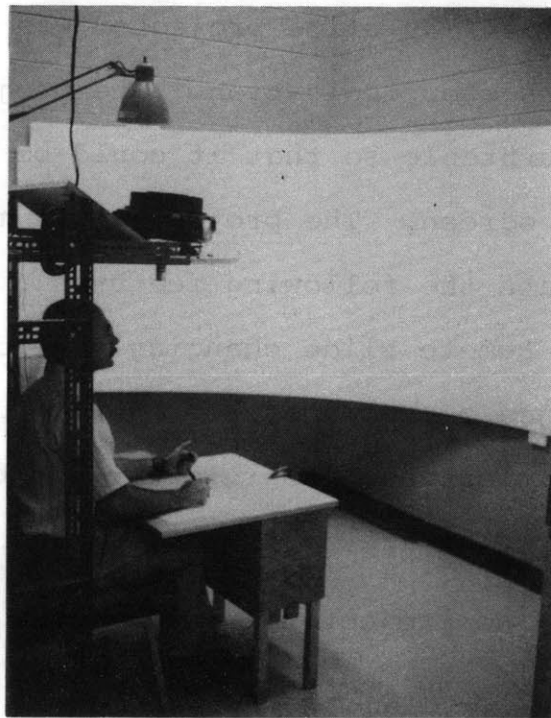

Figure 2.3 Subject Relative to Screen

2.2 Background Projectors

The three Kodak model 600 slide projectors were used to project a wide angle background scene onto the screen. Without slides, the three projectors provided an even 60 foot candles of light across the surface of the screen. This represented about the brightest white which could occur in the background scene. Ambient light in the room varied from 5 foot candles to 15 foot candles. This was essentially the darkest black which could occur in the background. Therefore, the maximum contrast ratios that could occur in the background were between 15 to 1 and 4 to 1. Two of the three projectors are shown in figure 2.4.

2.3 Target Projector

A Kodak model 750 slide projector was used to project the target and sector indication. The projector was mounted on a turntable so that it could be pointed at any portion of the screen. The projector was modified so as to incorporate the following features:

- (1) Remote slide changing. Slides could be changed on command from the computer. Slide selection was either forward or backward through a circular tray.
- (2) The projector lamp could be turned on or off via the computer.

Together, these modifications allowed the automated computer selection of any of the slides in the tray. In addition,



Figure 2.4: Two Background Projectors.

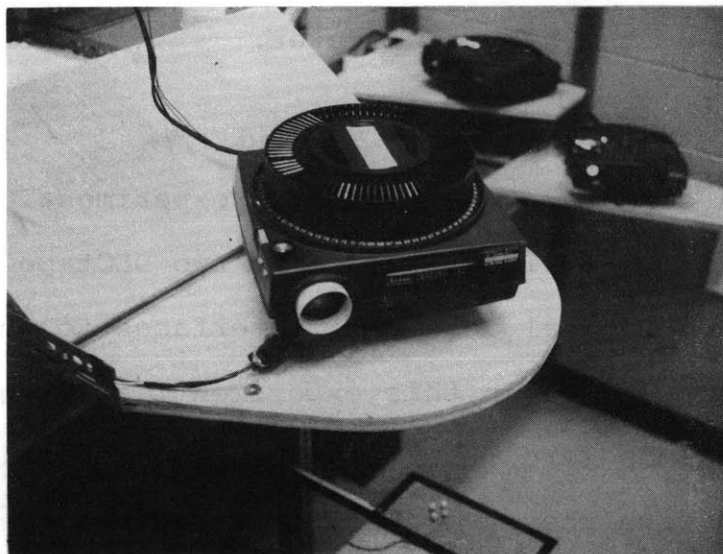

Figure 2.5: Target Projector on Turntable

the lens of the projector was fitted with two polarized filters which could be manually rotated against each other so as to vary the intensity. This allowed an easy adjustment of the contrast ratio between background and target. This projector is shown in Figure 2.5.

2.4 Turntable

The target projector was mounted on a low rpm turntable which could direct it toward any portion of the screen. The turntable turned at a constant speed of roughly one revolution per minute. The power supply needed to drive the motor was a 27 volt D.C. power supply. A feedback pot measured turntable position allowing closed loop control. Turntable movements and therefore target positionings were directed by the hybrid computer.

2.5 Hybrid Computer (Figures 2.6 and 2.7)

A hybrid computer controlled the experiment. It consisted of a PDP-8 with 4K of core, two DECTape drives, a teletype, and digital to analog interfaces to the GPS 290T analog computer. In this experiment, all logic and feedback functions were controlled via the digital portion of the system with the analog computer serving as an interface to relay open loop instructions to the equipment and conduct "sensory" measurements back to the digital logic. The computer selected the slides, controlled the turntable and provided timing of all events. In addition, the computer compiled relevant data during the execution of the experiment.

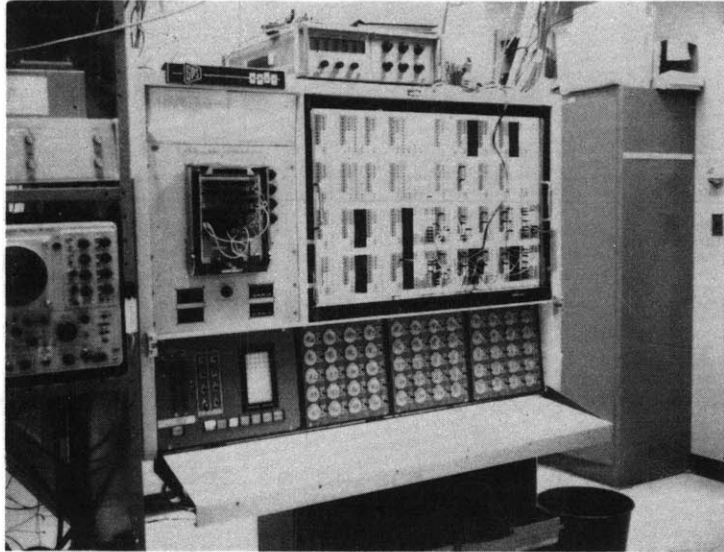

Figure 2.6: GPS 290T Analog Computer.



Figure 2.7: PDP-8 Digital Computer

CHAPTER 3

EXPERIMENTAL DESIGN AND PROCEDURES

The basic objective in the design of this experiment was to provide an efficient means of obtaining data on subject response to a number of idealized simulations of PWI warnings. In order for this basic objective to be met, it was necessary to conduct a large number of experimental trials varying several parameters. A highly automated means of performing this task was devised. With this technique, rapid data collection and repeated and varied trials were placed under computer control and combined with data reduction and analysis.

Computer control allowed for the rapid manipulations of several parameters. The parameters so controlled were as follows:

- (1) Horizontal position of the search sector on the screen. This simulated warnings from different azimuths.
- (2) Sector size. The area to be searched could

be varied in size simulating differing resolution PWI instrumentation.

(3) Background quality. The amount of visual clutter or noise in the background could be varied.

(4) Target contrast against the background. The conspicuousness of the target against the background could be varied by adjustment of 3 and 4.

(5) Position of the target within a given sector.

A single trial of the experiment followed a specific series of events.

First, the sector size and target position within the sector are selected. This is done by the selection of a single slide from the slide tray. Both the target and the selector indication are projected from the same slide. As mentioned previously, the sector indication is a white box which encloses the area to be searched. The target is a triangle within that box. It is elongated and points either up, down, left or right. Because the target position within a sector on a given slide is fixed, it is necessary

to have several slides with identical size sectors in order to vary target positioning within a sector. Once the slide has been chosen, it is loaded via the projector slide changing mechanism into a position ready for projection.

Slide selection is done automatically on command from the hybrid computer. Although the computer may easily select slides at random, this was not in fact done. The slides were stepped through sequentially in the forward direction until they were exhausted. The direction was then reversed and the same slides were backed through to the start slide by slide. On reaching the start, the process was repeated. A simple table stored in core memory provided the computer with the relevant information it needed to control this task. The slides were arranged in a pseudo random fashion within the tray so as to give the appearance of random slide selection.

After slide selection and loading, the projector is moved to point toward a particular portion of the screen. The projector is mounted on a turntable to facilitate this and a feedback pot measures projector position allowing closed loop control. Projector positioning is done by the computer under program control. In order to prevent the subject from attempting to track projector position

as a function of the time required for positioning the projector, a random walk to several intervening positions is employed. Projector movements are executed in accordance with the entries in another data table stored in core memory. Positioning is done with an accuracy of 1 part in 64 over a range of roughly 160 degrees or to about 2 or 3 degrees.

When the slide is ready and the projector correctly positioned, an alarm is sounded and the projector lamp is lit projecting the target and sector indications onto the screen. This projector has two polarized lenses which can be rotated against each other in order to vary target and sector indicator intensities. This allows differing contrast ratios between the target and the background. The adjustment of this ratio is done manually before each series of trials. The alarm is a square wave tone of roughly 800 cycles per second.

When the subject locates the target within the sector, he presses a hand held button. Both the alarm and projector lamp are shut off on this signal. The computer records the total elapsed time from the onset of the alarm until the button is pressed. Timing is done utilizing the variable clock in the GPS 290T computer. Resolution in time is to better than one thousandth of a second.

The subject is then required to identify which direction the target was pointing. He indicates this response by pressing one of four buttons. Data from the trial is compiled into running statistical sums if he correctly identified the target. If he cannot, an error is recorded. If the subject is unable to locate the target within 32 seconds, the alarm and lamp are shut off and an error is recorded. While the computer is waiting to receive the target identification from the subject, the next slide is selected and the projector positioning initiated.

The subject is required to work on a secondary task during slack moments between trials. This task involves the marking of a table of random numbers identifying specific number patterns. Specifically, the subject was asked to mark chains of three increasing or decreasing digits. The exact nature of the task is described in great detail in the instructions to the subject, a copy of which is enclosed in the appendix.

Data from each trial is collected by the computer. At the end of each trial, this data is analyzed and combined with data from previous trials. In this fashion, data analysis and reduction takes place as the experiment is running.

Data from a single trial is combined with data from similar trials. The experimenter is free to define what characteristics the computer should use in defining or setting up these trial groupings. Sector size, target positioning within the sector, sector heading or any combination of the above may be used to define trial groupings. The computer has a capacity to accumulate statistics on up to 24 such groupings. For this thesis, the sector's size was used as the grouping parameter. Different series of runs were made for different target contrast and background conditions with the computer providing an instant analysis of the data broken down by sector size for each run.

Briefly, each statistical abstraction of data for one particular grouping or sector size includes the following data:

- (1) Number of trials making up this group
- (2) Number of valid trials included within this group. A valid trial is one in which the subject located the target within 32 seconds and was able to correctly identify it.
- (3) Mean response time. This is the mean or average time required to locate the target. This

is the mean of the valid trials.

(4) Variance. This is the square of the standard deviation among the response times of the valid trials.

(5) Histogram of data. This is a simple compilation of a number of trials with reaction time lying in certain time intervals. The time intervals were broken down into half second segments from 0 to 27 seconds. The last segment 27.0 - 27.5 seconds also includes 27.5 - 32.0 seconds.

Subjects were run under various background and contrast conditions. Basically, contrast between background and target was adjusted by means of the double polarized lens on the target projector. Contrast within the background, that is, difference between maximum bright spots and maximum dark spots, was adjusted by changing the ambient light level in the room. This was done by changing the wattage of a single light source mounted just above the target projector.

A series of about 20 subjects was used and an attempt was made to limit the number of repeated subjects so as to eliminate any learning which might take place during

repeated exposure to the mechanization of this experiment. Each series of runs was about 30 minutes long and included about 80 trial events.

CHAPTER 4

SUMMARY OF DATA4.1 General Form Used in Data Presentation

Over 800 separate trials were conducted in order to compile the statistics presented in this thesis. Naturally, with such a large amount of raw data available, it was necessary to develop a means of summarizing the data in order to properly evaluate it.

Basically, two distinct series of trial runs were made. The first series of trials was conducted with a highly cluttered background. The search for the target against such a background might be compared in difficulty to the problem of locating another aircraft against the cluttered background of the ground below. A second series of runs was conducted against a much brighter and less cluttered background. This represented the task of locating a plane against the sky.

The background used in the first portion of the study was a speckled scene with each bright speckle being slightly smaller than the target. The region between speckles was relatively dark. Speckles were about 15 times as bright

as the dark regions between them. The light projected on the surface of the white screen formed a speckled pattern which was 60 foot candles bright at the center of a speckle and 4 foot candles bright between speckles. A photograph of the highly speckled background is shown in Figure 4.1. Beneath the high contrast background is the brighter, more uniform background used in the second series of runs. This background is similar to the first except that the blobs are not as clearly defined. The maximum contrast between the lightest and darkest region has been reduced to about 4 to 1. The lightest regions are about 80 foot candles bright and the darkest regions are about 20 foot candles bright.

Within a single series, several sets of trials were run with targets of different brightness. Each of these smaller sets of trials included about 100 trial events. For each set, the brightness of the target was adjusted manually by means of the polarized lenses. This allowed an examination of the subject's reaction time as a function of target contrast and conspicuousness. At each of these fixed brightness levels, the subject was presented with a random mix of trial situations using differing sector sizes located at randomly selected headings.

Data is grouped such that all trials with the same sector size, target intensity and background are combined into one statistical picture. For a single group, these

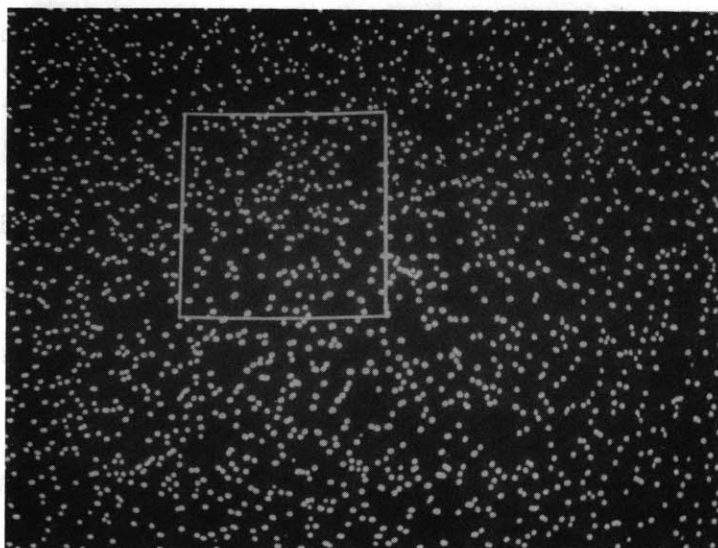

Figure 4.1: High Contrast Background

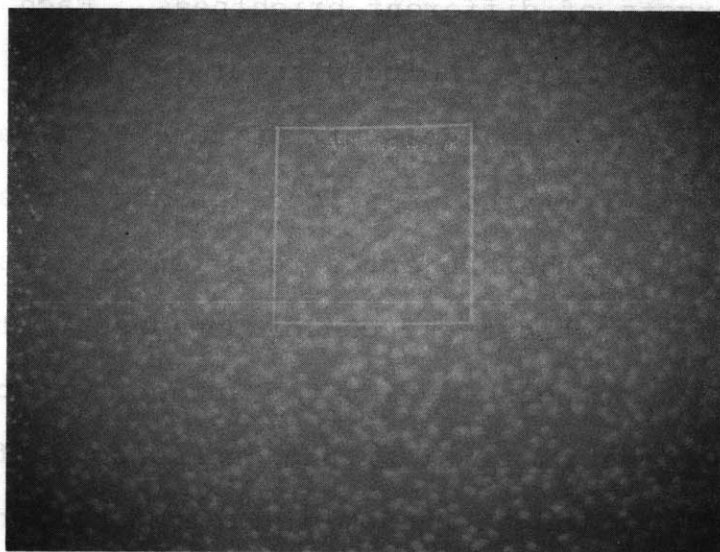

Figure 4.2: Uniform Background

statistics are reported on single pages in Section 4.2. The data items concerning a single data group are as follows:

- (1) Background used; either high or low contrast.
- (2) Target brightness; target projector light intensity at the surface of the screen.
- (3) Sector size; field of view covered by the search sector.
- (4) Mean time; the mean time required for the subject to locate the target.
- (5) Standard deviation; the standard deviation of the time required to locate the target.
- (6) Error rate; the percentage of trials in which the subject fails to correctly identify the target.
- (7) Histogram of results; this is a graphical abstract of the data. The time axis is broken down into half second intervals and the percentage of trials with response times falling in the various half second intervals is shown. The bar labelled "e" on the graph represents the error rate.

It should be noted that, in some of the graphs, the

data seems somewhat coarse. This coarseness is a function of the number of trials used in generating the data. If larger numbers of trials were made, it would be expected that the data might fit under a smoother envelope. The difficulty in performing greater numbers of trials for a single set of parameters more than outweighs the refinement in data possible with this increased effort. The decision was made to cover a larger number of basic parameter combinations rather than concentrate too heavily on a limited set of parameter combinations.

4.2 Tables of Results

Figures 4.3 through 4.27 summarize the data collected for this thesis.

High Contrast Background

Sector Size = $2.7^\circ \times 2.7^\circ$

Target Intensity = 20 foot candles

Mean = 2.3 Median = 2.3

Standard Deviation = .37

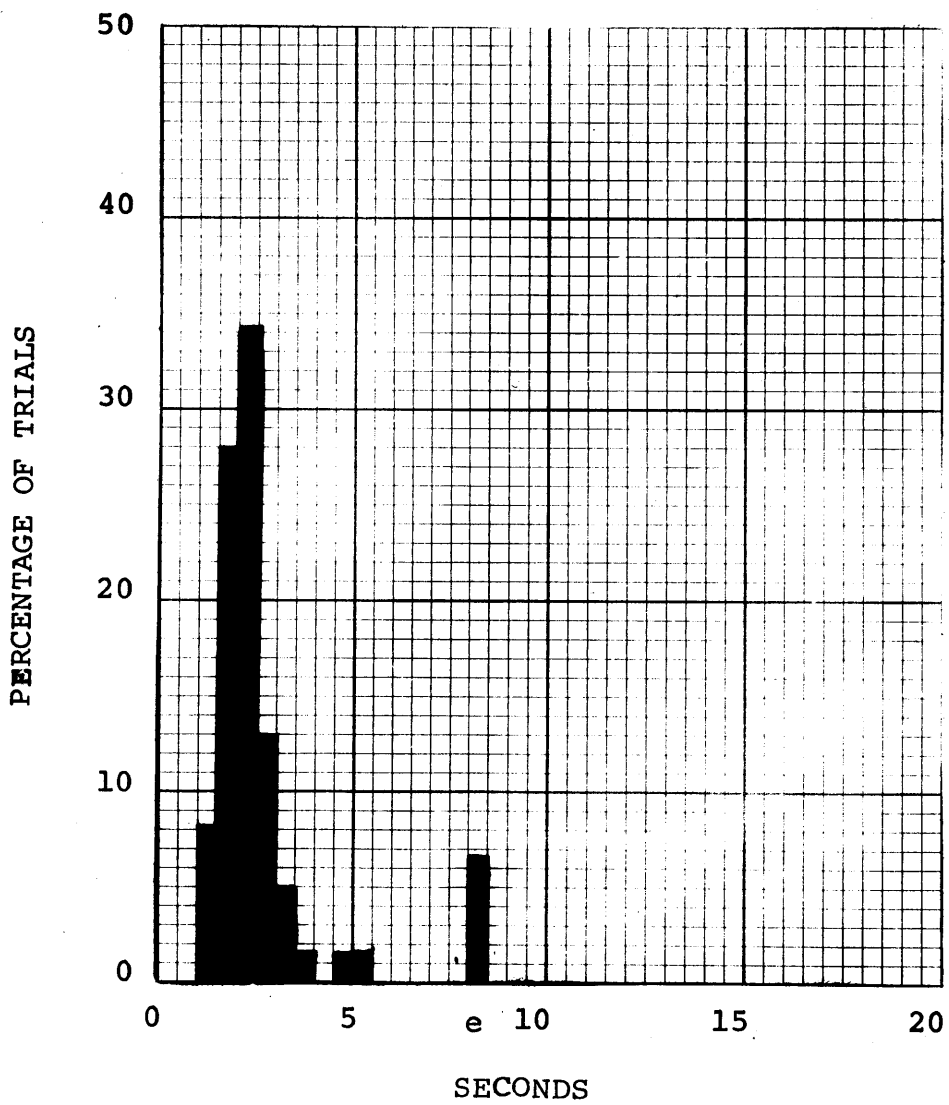

Figure 4.3

High Contrast Background

Sector Size = $5.5^\circ \times 5.5^\circ$

Target Intensity = 20 foot candles

Mean = 2.4 Median = 2.4

Standard Deviation = .65

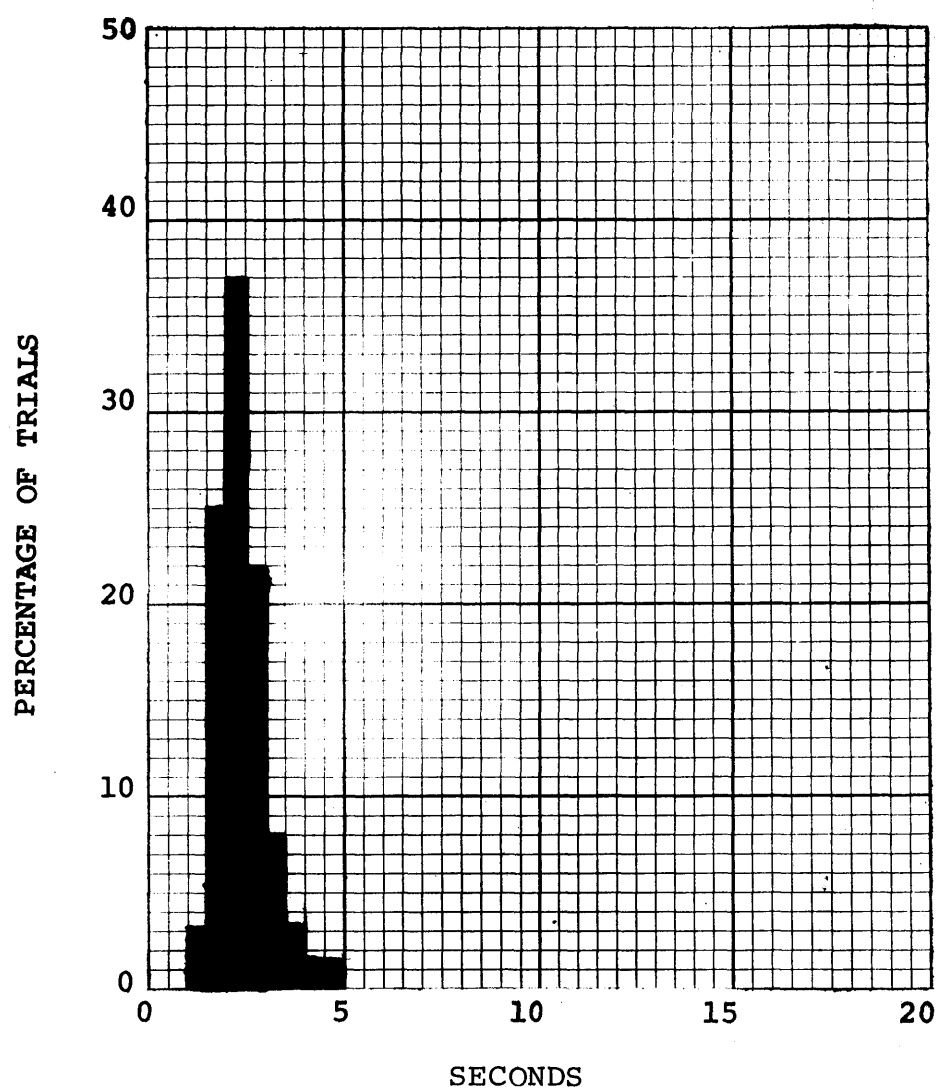

Figure 4.4

High Contrast Background

Sector Size = $11^\circ \times 11^\circ$

Target Intensity = 20 foot candles

Mean = 3.3 Median = 2.6

Standard Deviation = 2.9

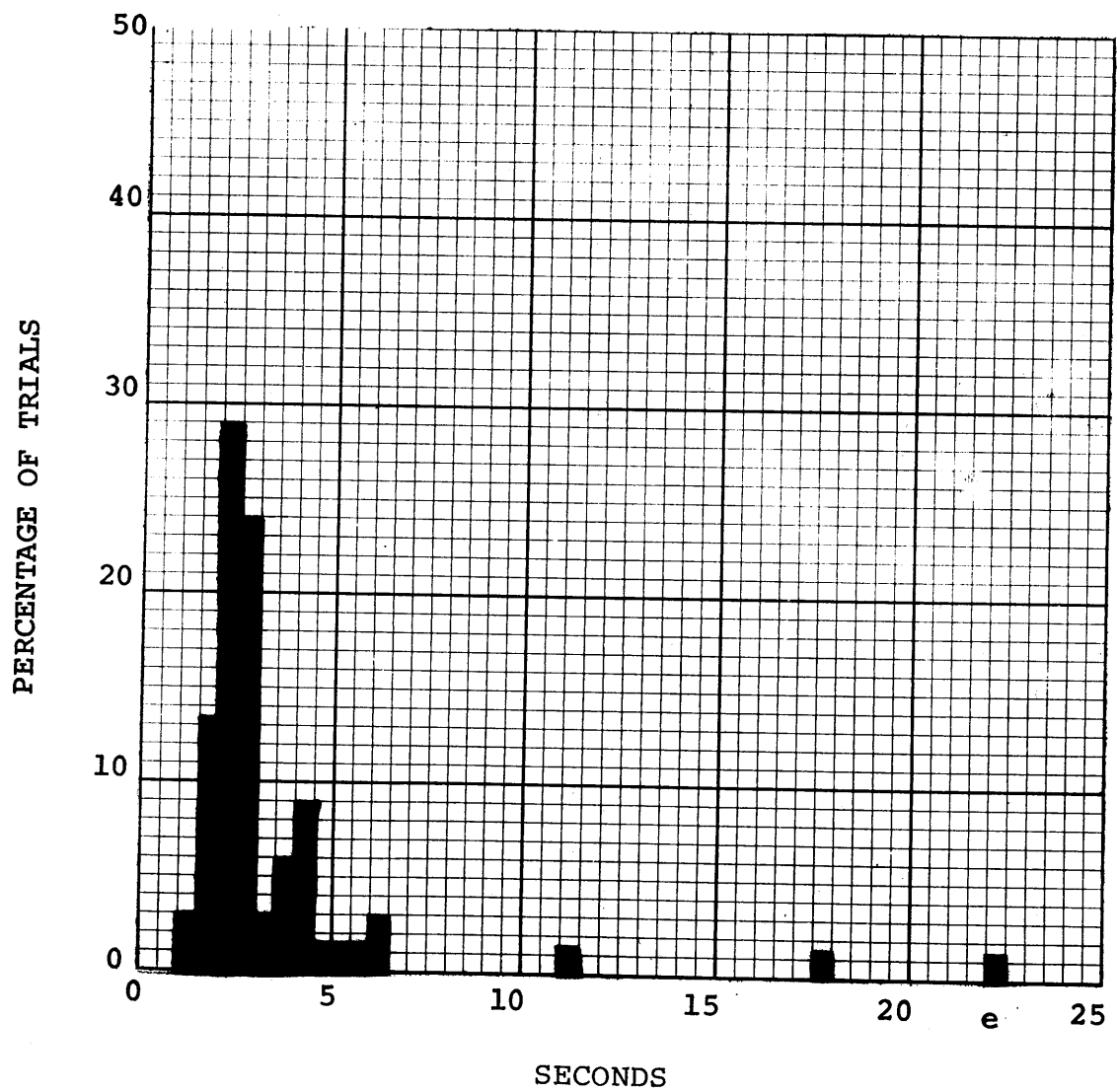

Figure 4.5

High Contrast Background

Sector Size = $22^\circ \times 22^\circ$

Target Intensity = 20 foot candles

Mean = 7.9 Median = 8.0

Standard Deviation = 5.6

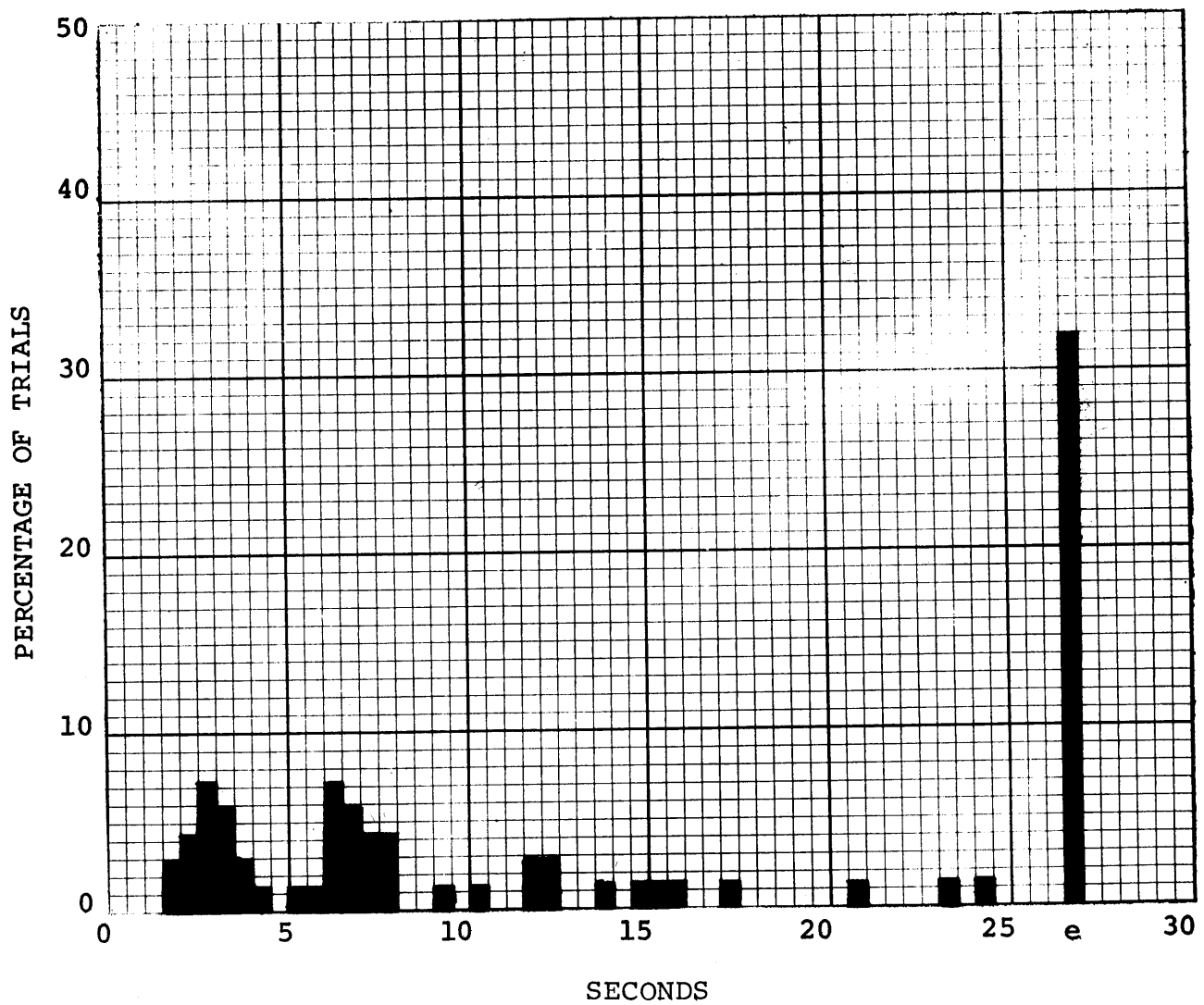

Figure 4.6

High Contrast Background

Sector Size = $2.7^\circ \times 2.7^\circ$

Target Intensity = 35 foot candles

Mean = 1.7 Median = 1.7

Standard Deviation = .40

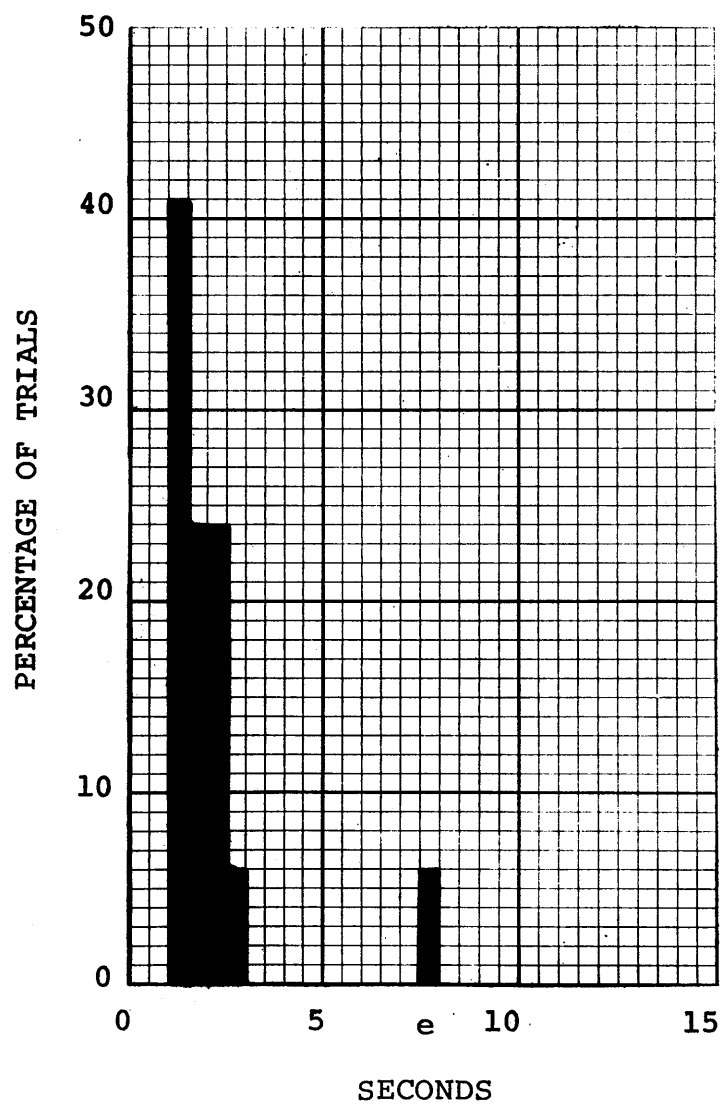

Figure 4.7

High Contrast Background

Sector Size = $5.5^\circ \times 5.5^\circ$

Target Intensity = 35 foot candles

Mean = 1.6 Median = 1.6

Standard Deviation = .33

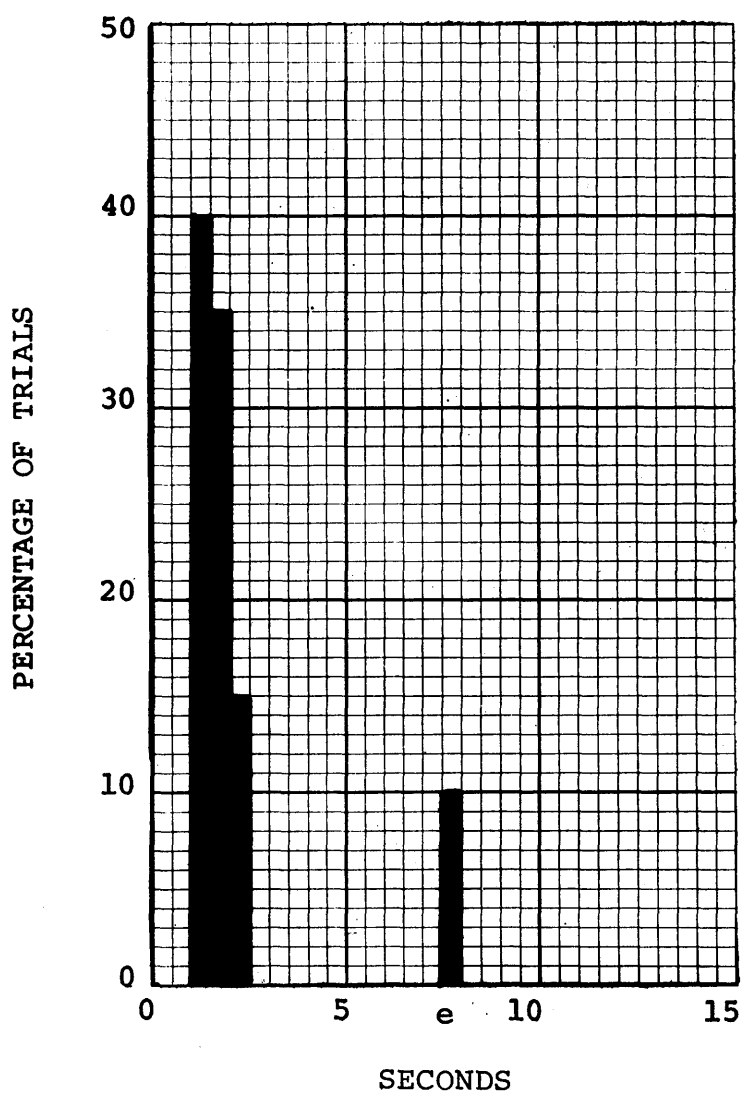

Figure 4.7

High Contrast Background

Sector Size = $11^\circ \times 11^\circ$

Target Intensity = 35 foot candles

Mean = 2.1 Median = 1.9

Standard Deviation = .75

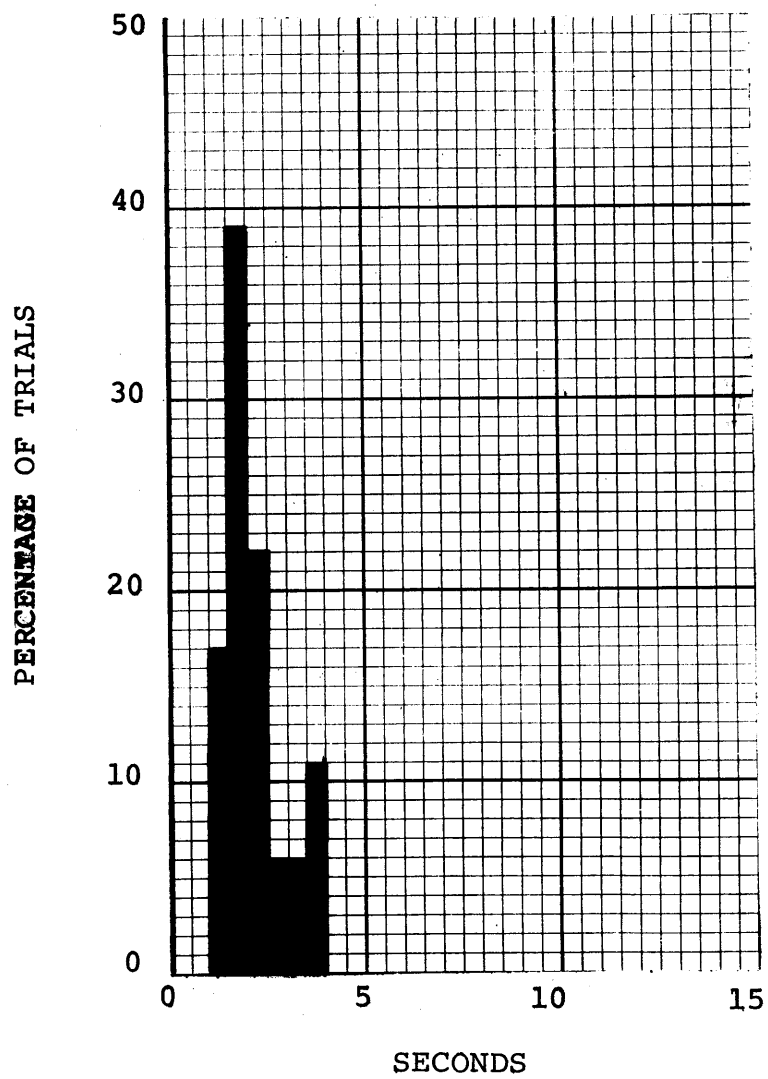

Figure 4.8

High Contrast Background

Sector Size = 22° X 22°

Target Intensity = 35 foot candles

Mean = 7.1 Median = 8.4

Standard Deviation = 6.0

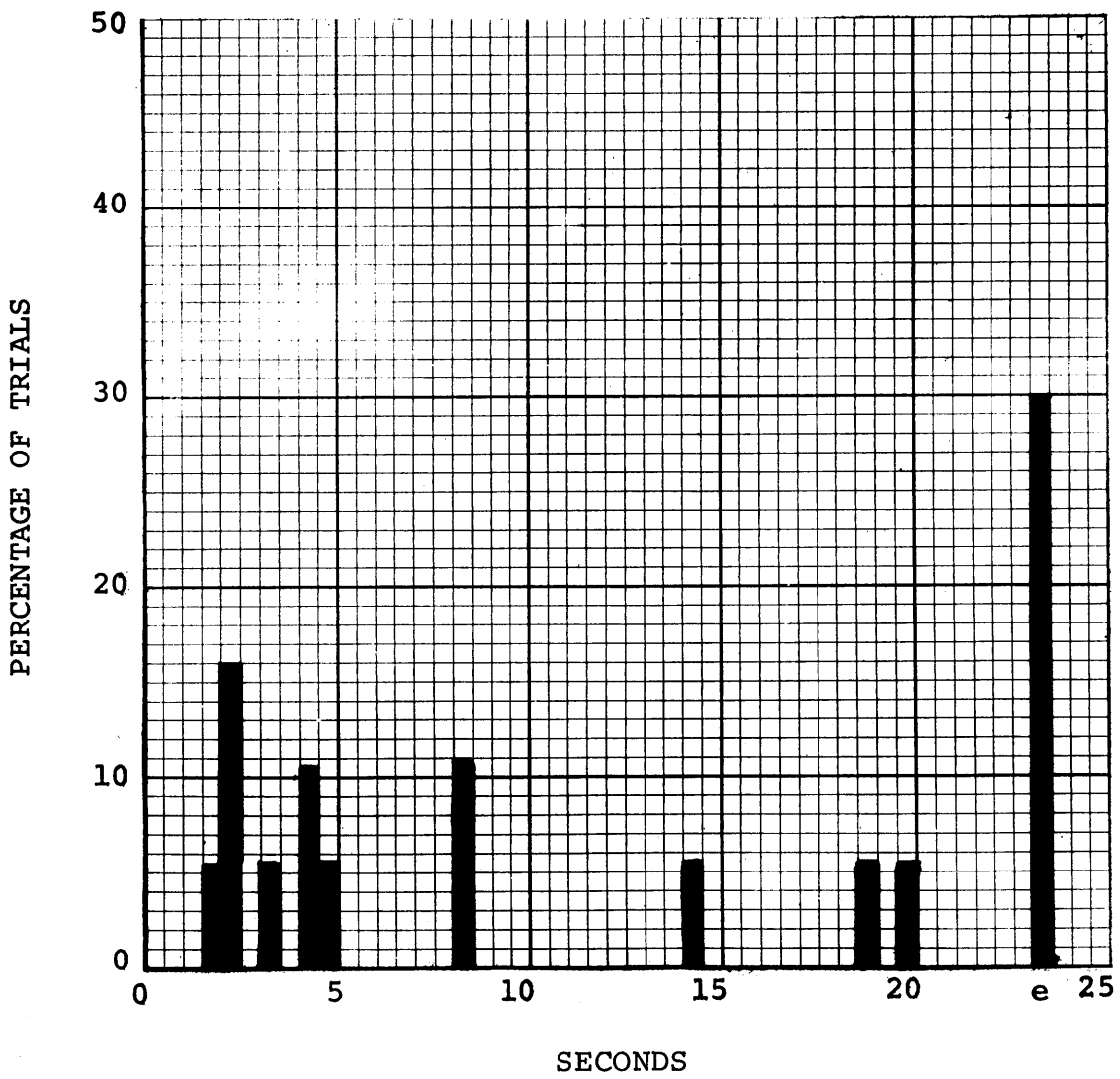

Figure 4.9

High Contrast Background

Sector Size = $2.7^\circ \times 2.7^\circ$

Target Intensity = 45 foot candles

Mean = 2.9 Median = 3.0

Standard Deviation = 1.2

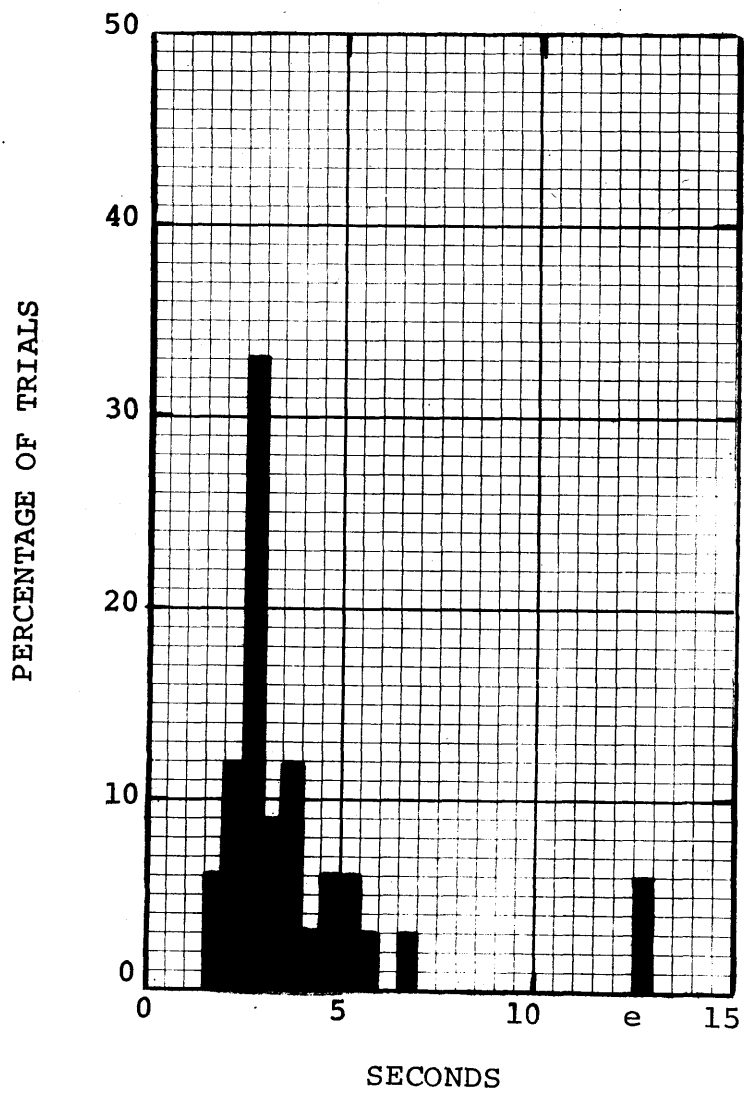

Figure 4.10

High Contrast Background

Sector Size = $5.5^\circ \times 5.5^\circ$

Target Intensity = 45 foot candles

Mean = 2.8 Median = 2.7

Standard Deviation = .94

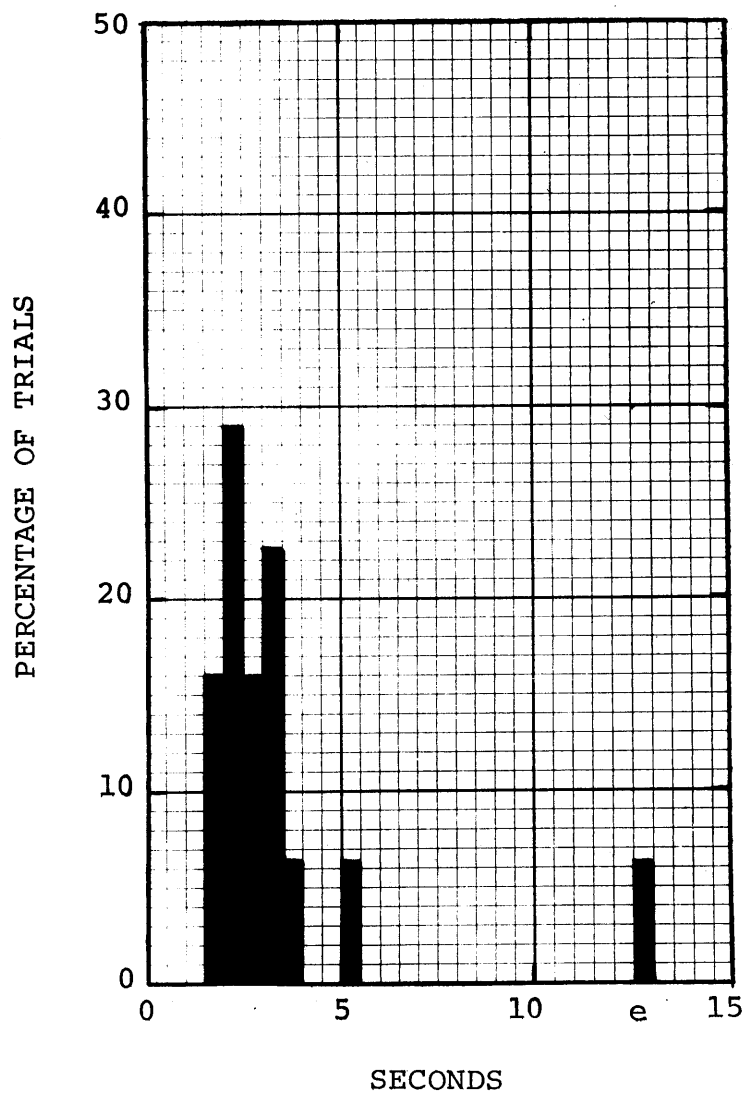

Figure 4.11

High Contrast Background

Sector Size = $11^\circ \times 11^\circ$

Target Intensity = 45 foot candles

Mean = 3.4 Median = 2.8

Standard Deviation = 1.2

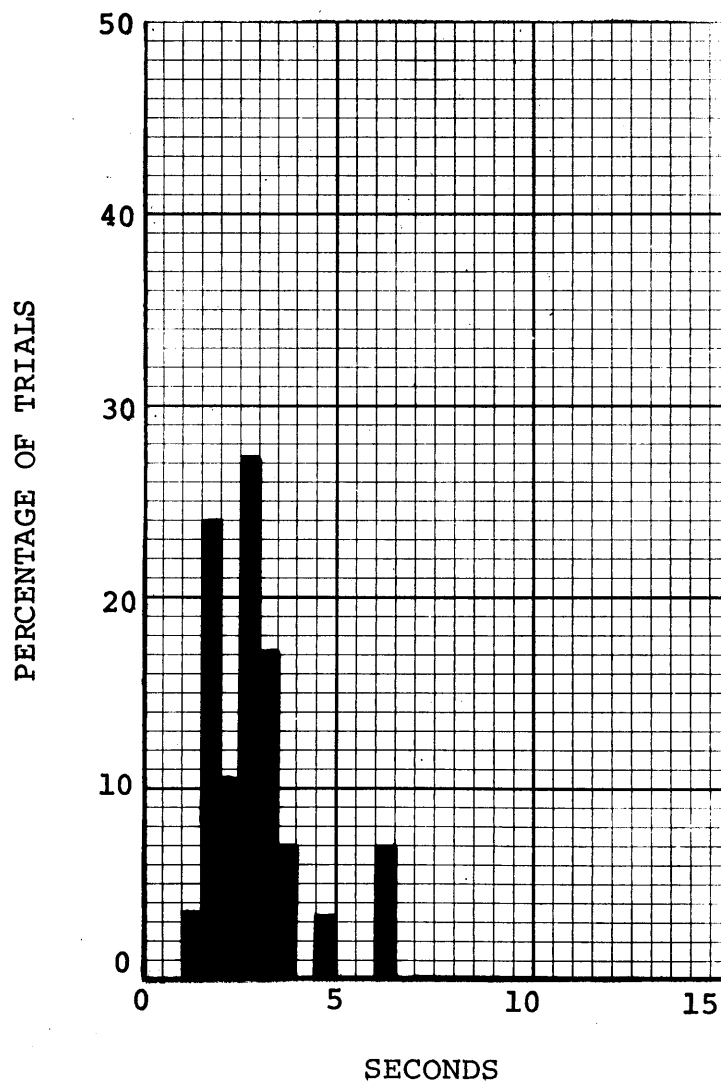

Figure 4.12

High Contrast Background

Sector Size = $22^\circ \times 22^\circ$

Target Intensity = 45 foot candles

Mean = 9.1 Median = 6.0

Standard Deviation = 8.4

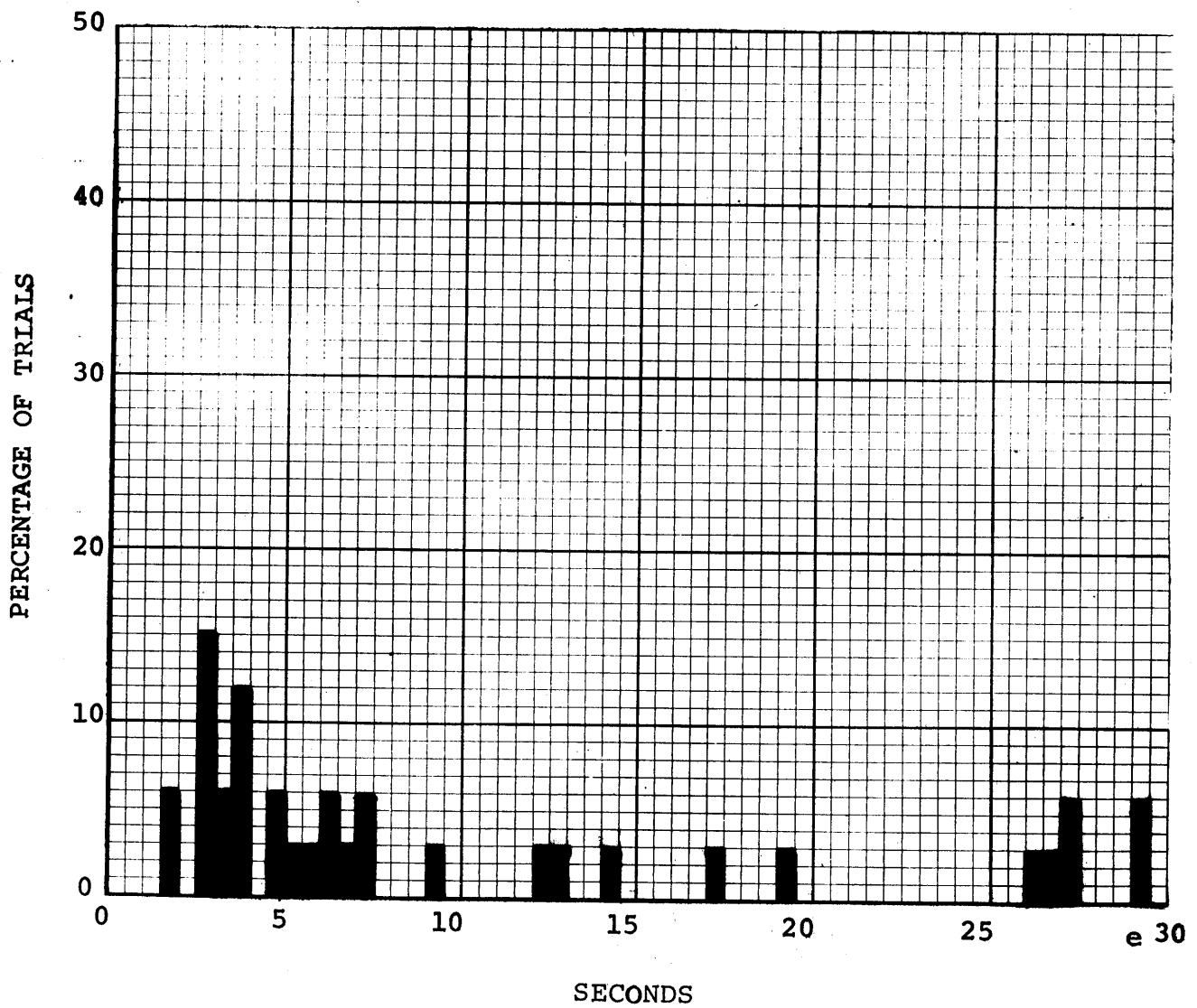

Figure 4.13

High Contrast Background

Sector Size = $2.7^\circ \times 2.7^\circ$

Target Intensity = 55 foot candles

Mean = 1.5 Median = 1.3

Standard Deviation = .56

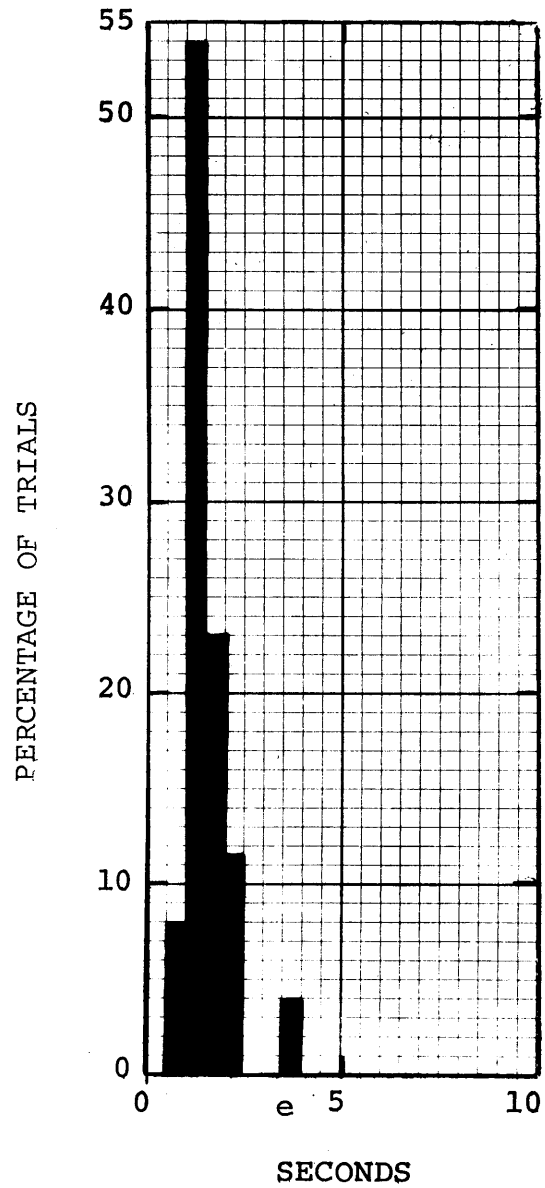

Figure 4.14

High Contrast Background

Sector Size = $5.5^\circ \times 5.5^\circ$

Mean = 1.4 Median = 1.3

Target Intensity = 55 foot candles

Standard Deviation = .32

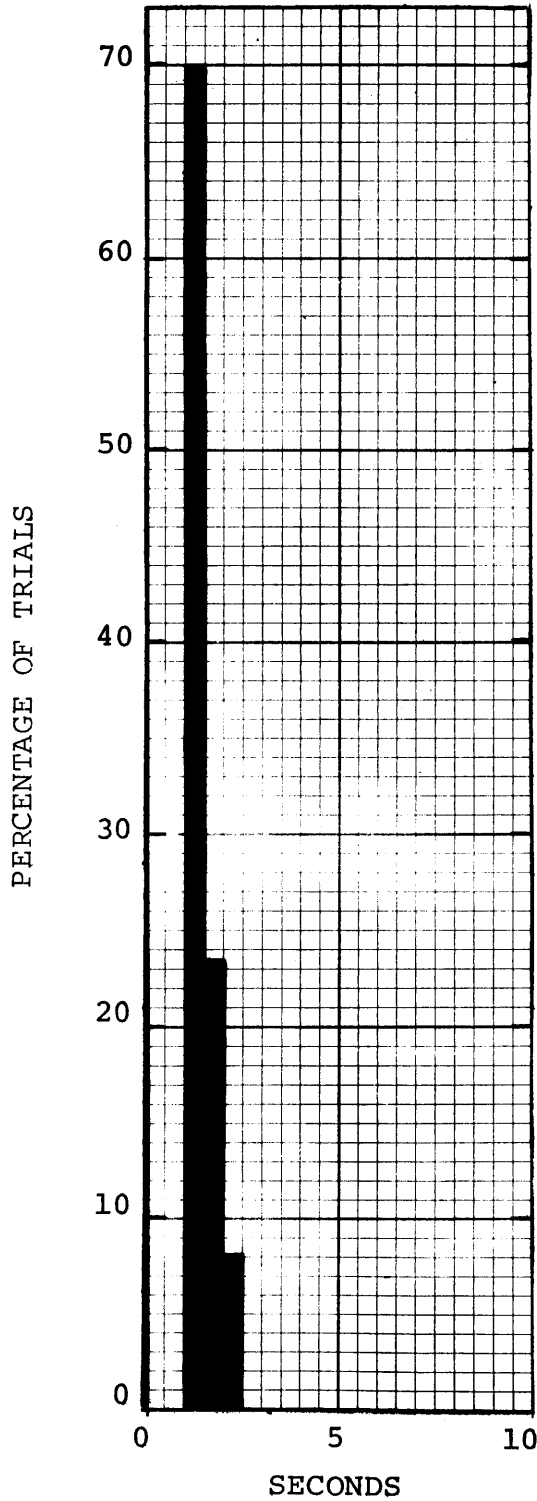

Figure 4.15

High Contrast Background

Sector Size = 11° X 11°

Mean = 1.45 Median = 1.4

Target Intensity = 55 foot candles

Standard Deviation = .31

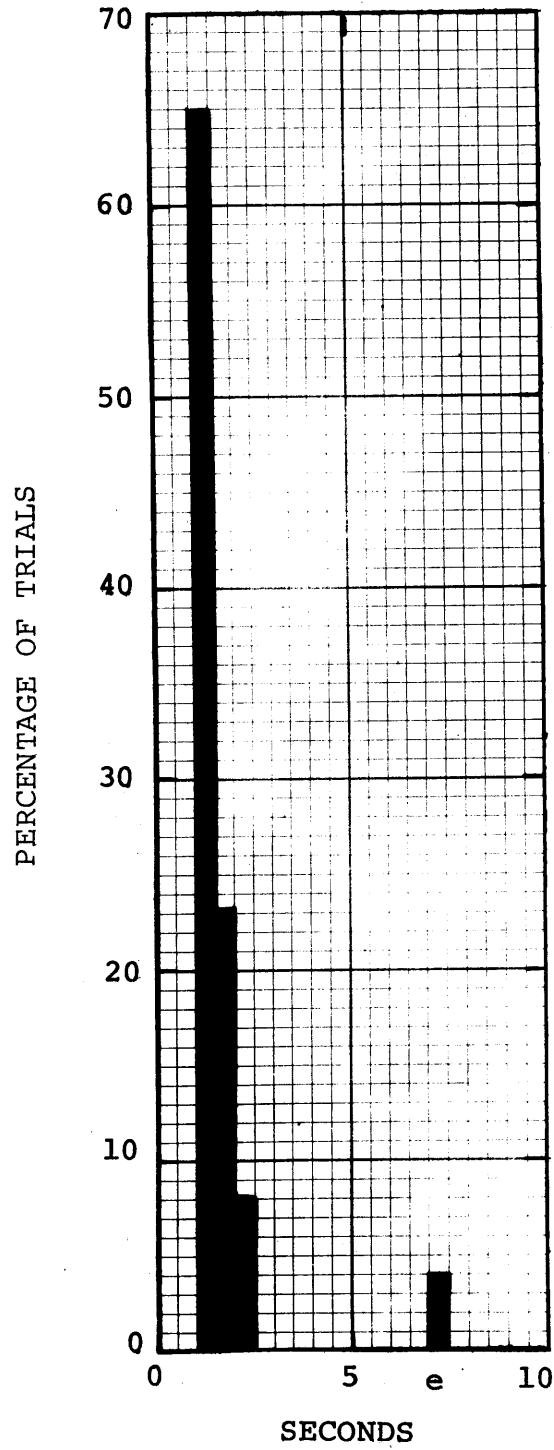

Figure 4.16

High Contrast Background

Sector Size = $22^\circ \times 22^\circ$

Target Intensity = 55 foot candles

Mean = 2.9 Median = 2.1

Standard Deviation = 1.8

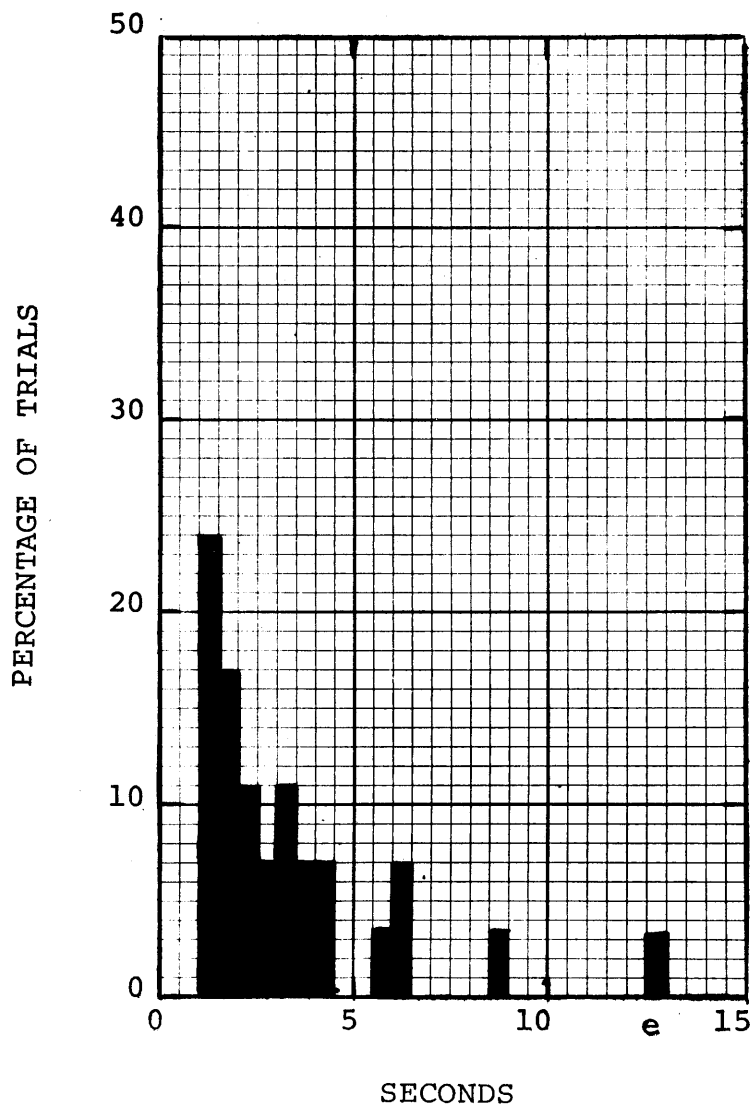

Figure 4.17

Uniform Background

Sector Size = $2.7^\circ \times 2.7^\circ$

Target Intensity = 25 foot candles

Mean = 3.9 Median = 4.0

Standard Deviation = 1.1

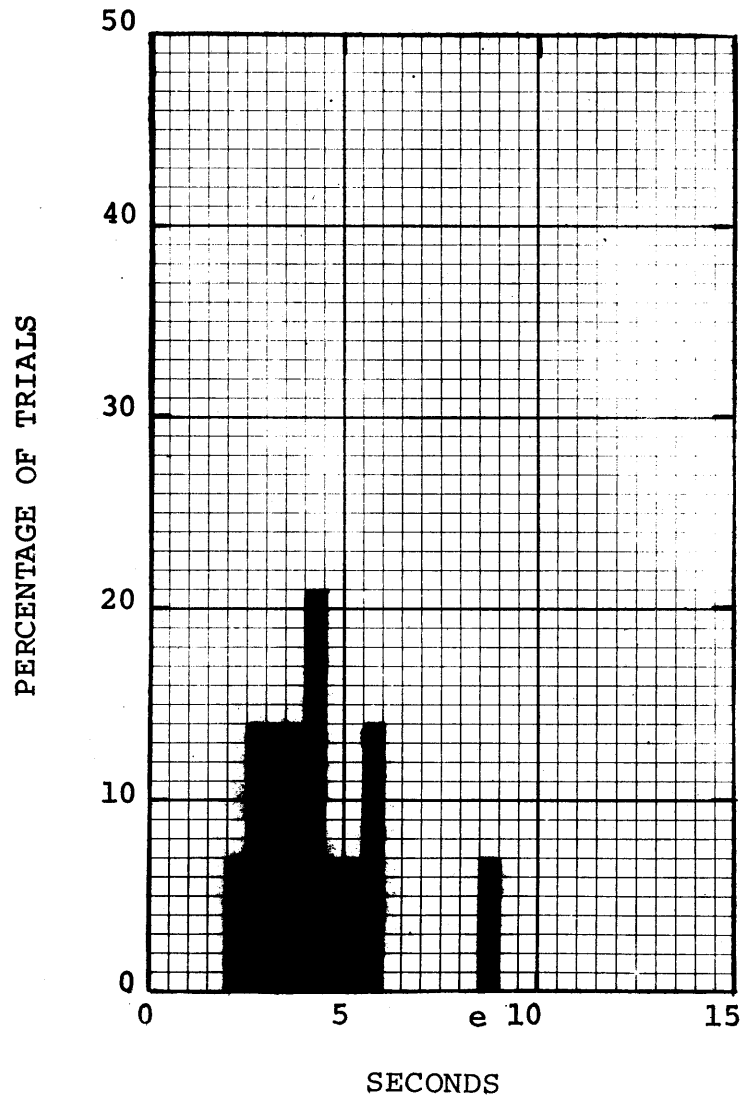

Figure 4.18

Uniform Background

Sector Size = $5.5^\circ \times 5.5^\circ$

Target Intensity = 25 foot candles

Mean = 5.9 Median = 5.3

Standard Deviation = 3.1

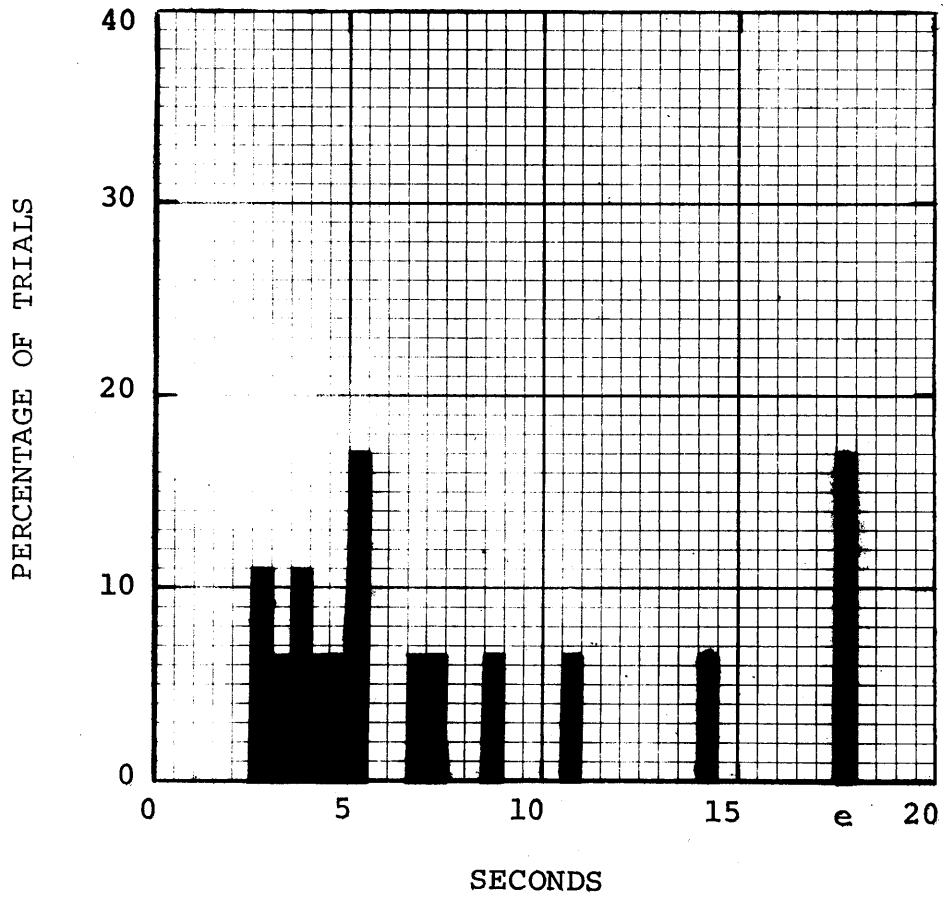

Figure 4.19

Uniform Background

Sector Size = $11^\circ \times 11^\circ$

Target Intensity = 25 foot candles

Mean = 7.3 Median = 7.4

Standard Deviation = 4.5

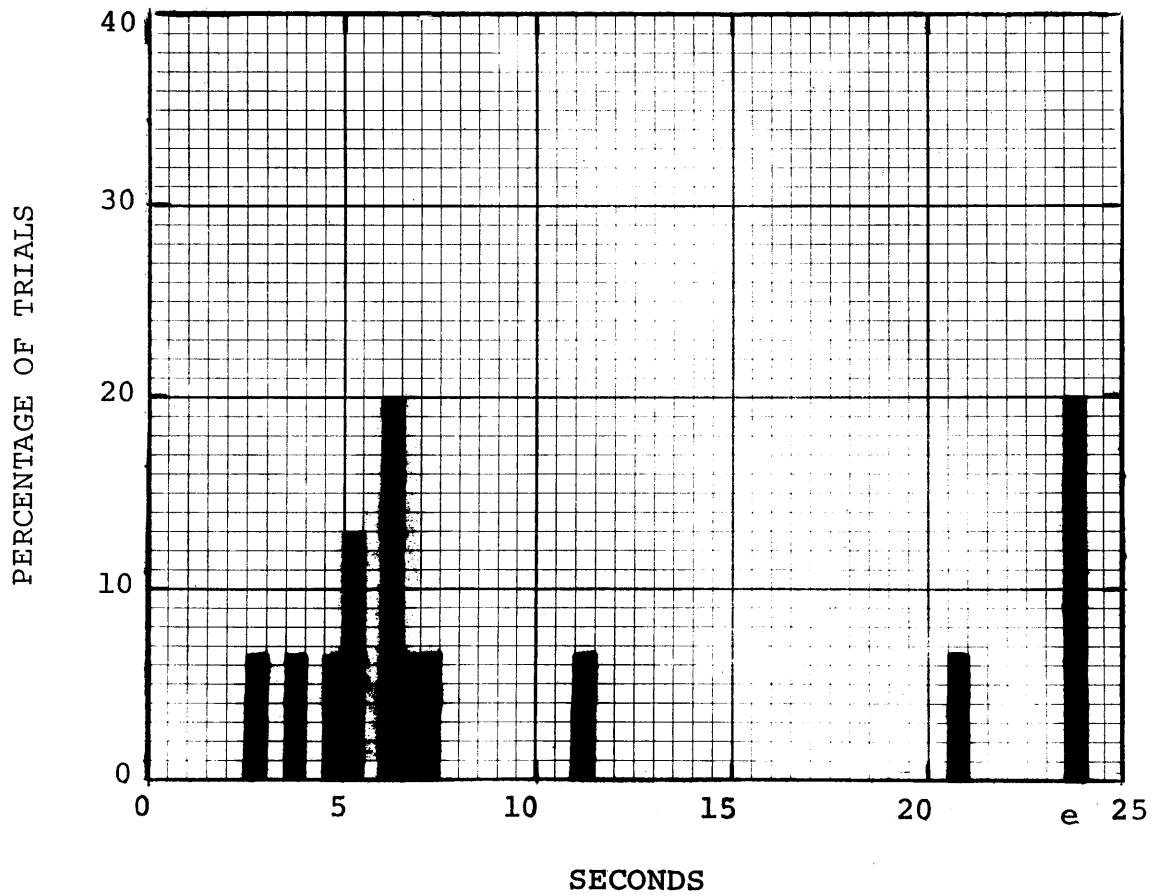

Figure 4.20

Uniform Background

Sector Size = $2.7^\circ \times 2.7^\circ$

Target Intensity = 50 foot candles

Mean = 2.2 Median = 2.2

Standard Deviation = .46

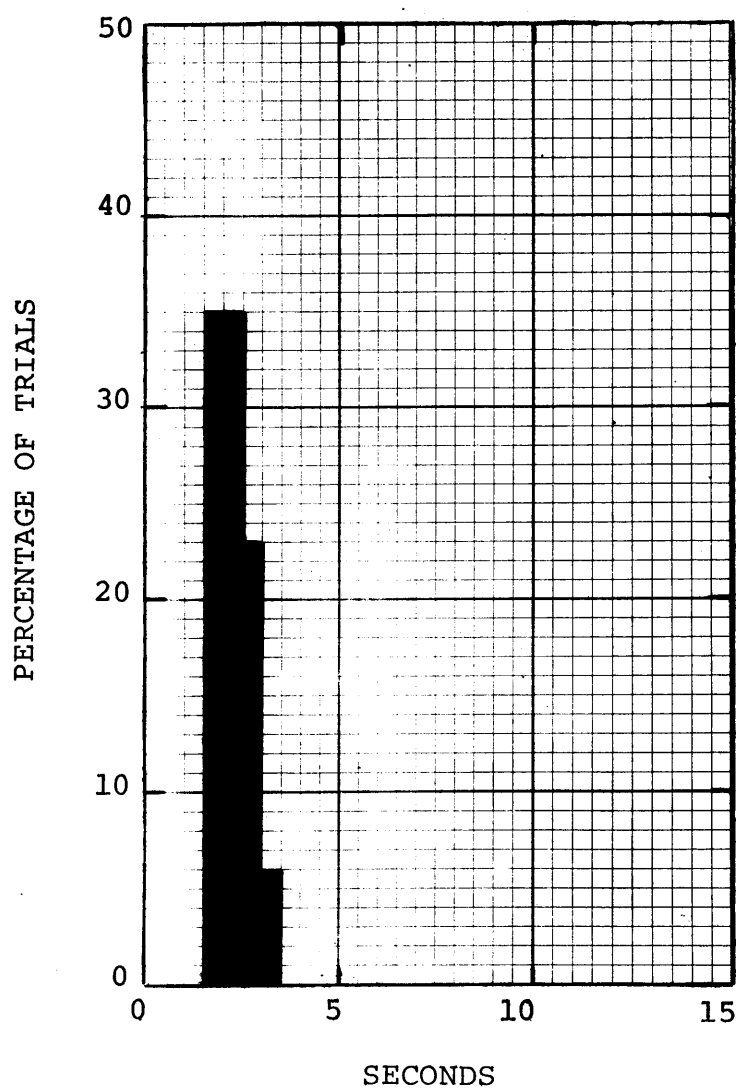

Figure 4.21

Uniform Background

Sector Size = $5.5^\circ \times 5.5^\circ$

Target Intensity = 50 foot candles

Mean = 3.5 Median = 3.1

Standard Deviation = 1.5

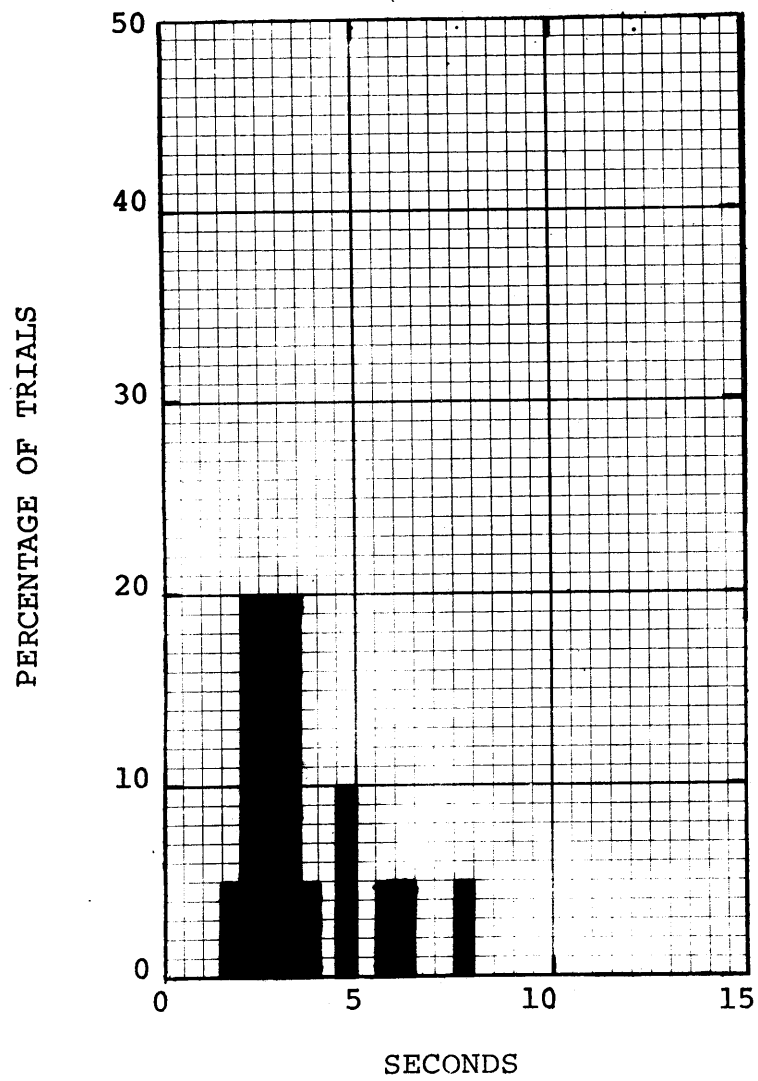

Figure 4.22

Uniform Background

Sector Size = $11^\circ \times 11^\circ$

Target Intensity = 50 foot candles

Mean = 6.9 Median = 4.5

Standard Deviation = 6.1

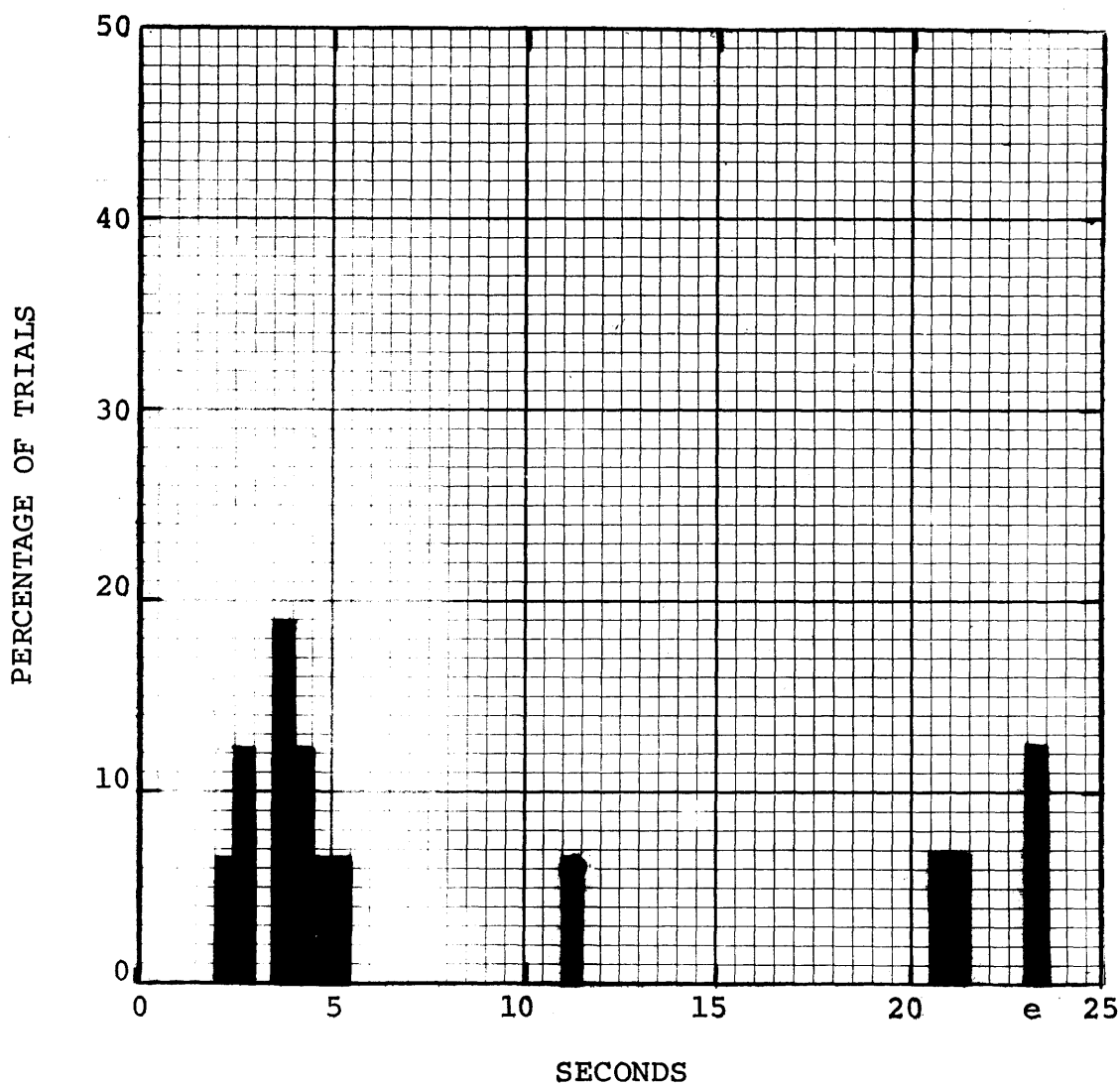

Figure 4.23

Uniform Background

Sector Size = $2.7^\circ \times 2.7^\circ$

Target Intensity = 75 foot candles

Mean = 1.7 Median = 1.7

Standard Deviation = .49

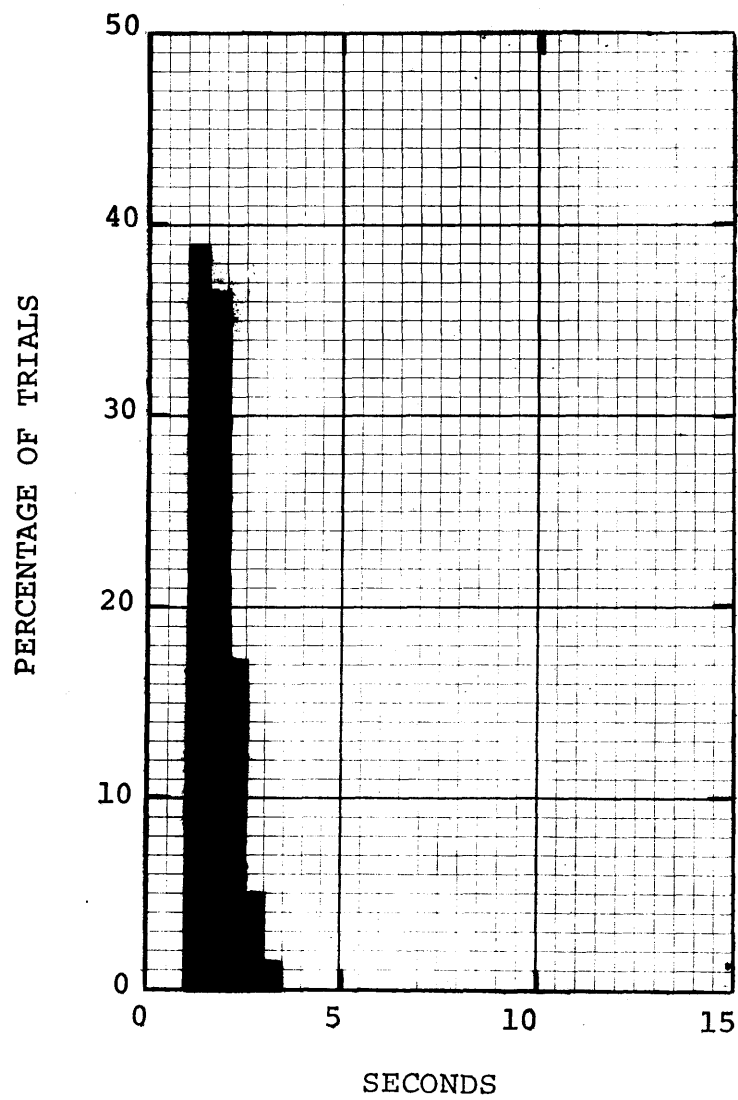

Figure 4.24

Uniform Background

Sector Size = $5.5^\circ \times 5.5^\circ$

Target Intensity = 75 foot candles

Mean = 1.7 Median = 1.7

Standard Deviation = .36

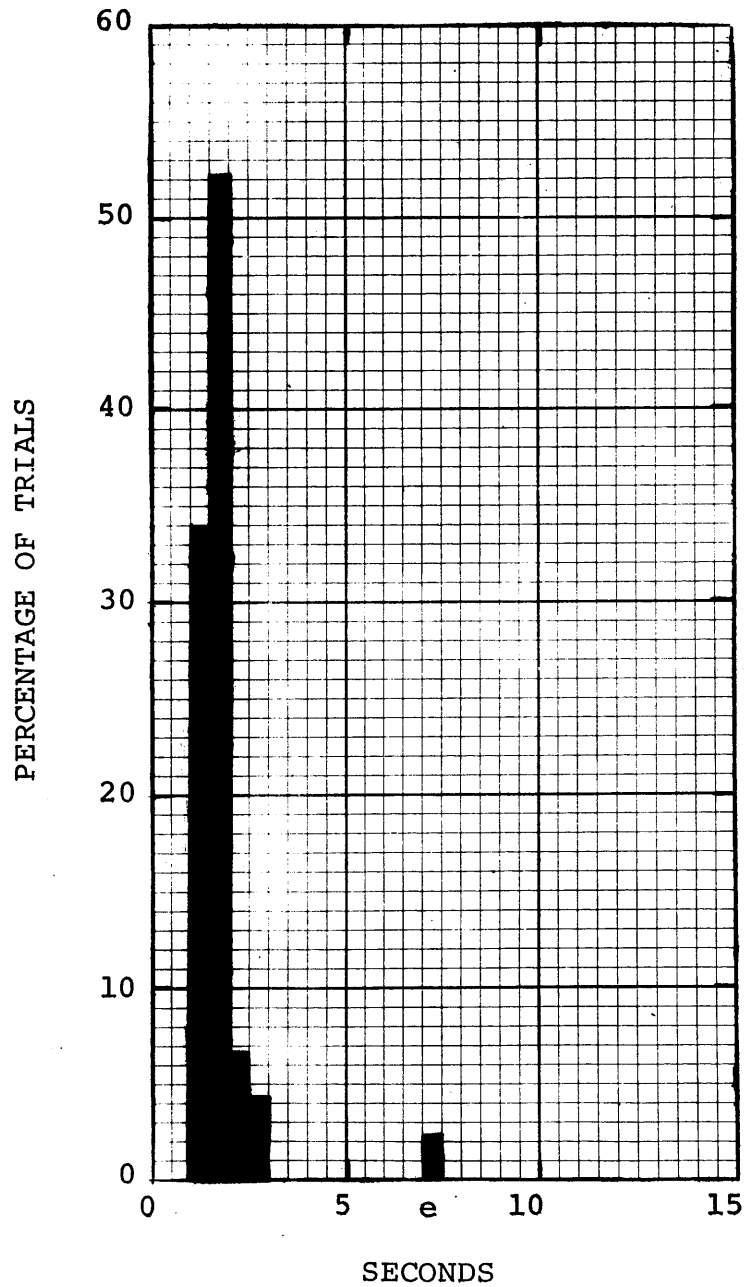

Figure 4.25

Uniform Background

Sector Size = $11^\circ \times 11^\circ$

Target Intensity = 75 foot candles

Mean = 2.1 Median 1.9

Standard Deviation = .68

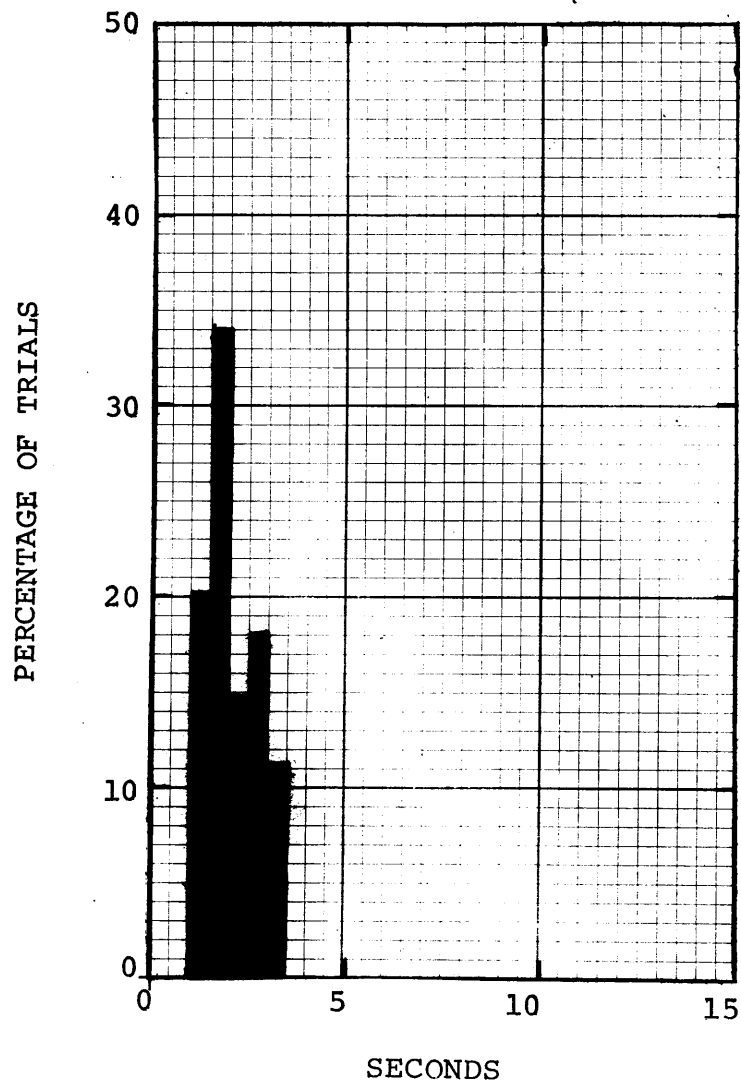

Figure 4.26

Uniform Background

Sector Size = $22^\circ \times 22^\circ$

Target Intensity = 75 foot candles

Mean = 6.5 Median = 7.2

Standard Deviation = 4.6

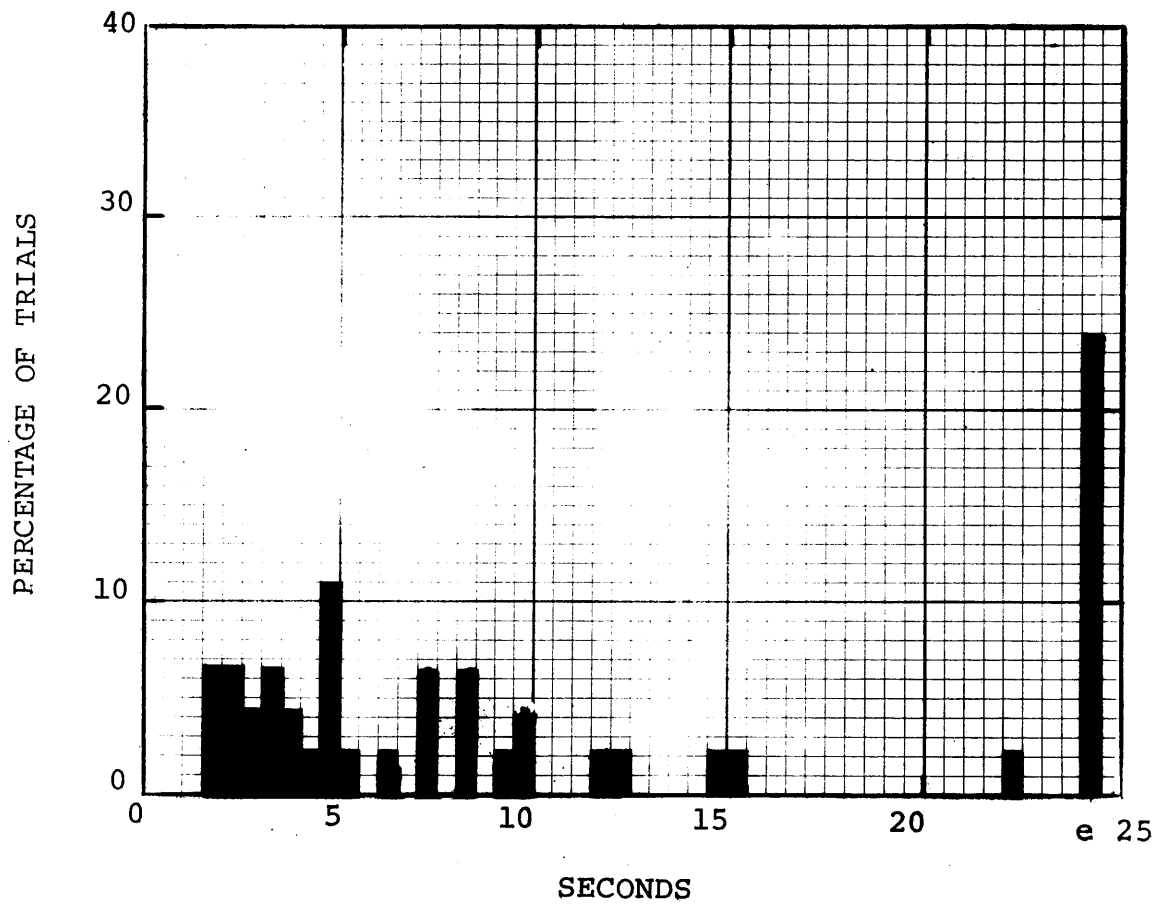

Figure 4.27

4.3 Evaluation of the Secondary Task

Subjects were broken down into roughly two categories by their performance on the secondary task. The first group of subjects tended to progress rather slowly through the task making very few errors. The second group processed the random numbers about three times as fast, but had a very high error rate. The accurate group worked through about 10 lines of 50 digits each, while the inaccurate group went through about 27 lines with an average error rate of about one missed or incorrectly marked chain for every two correctly marked chains.

Between these two groups, there was little difference in the performance of the primary task. The single exception to this rule was one subject who performed with utter zeal on the secondary task, progressing through about 40 lines, achieving an all time high in the number of errors made and setting some sort of record as to the lack of attention paid to the primary task. Data from this run appears in the third set of tables, Figures 4.10 through 4.13 of Section 4.2. This factor accounts for the unusually poor performance shown by that group of subjects and may illustrate the effect of heavy pilot workload on PWI effectiveness. Judging from general performance on the primary task, it would seem that both the accurate and inaccurate groups devoted equal effort to the secondary task. Because of this, the data can be viewed as representing equal subject loading.

CHAPTER 5

DISCUSSION OF RESULTS5.1 Comparison of Subject Performance Under Differing
Backgrounds

The most surprising result of this experiment was the fact that, with equivalent contrast ratios between target and screen brightness, most subjects performed markedly better with the highly cluttered background than with the more uniform one. Initially, a reasonable guess would have been to suspect that the uniform background would ease the task of locating the target since it was the only sharply defined object in the sector. This would also have seemed true because the cluttered background contained many items which were similar in size and shape to the target. With the cluttered background, the subject had to essentially locate the triangle by rejecting all other possible candidates in the sector. Despite this, he was able to quickly locate the target even when it was almost completely hidden under a bright speckle.

A possible explanation of this phenomenon is that the uniform background gave the subject nothing to focus on,

possibly forcing him to scan the sector without his vision being focused at the surface of the screen. Because of this, the triangle would not have appeared sharp and would therefore have been more difficult to locate. This would imply that, for a PWI instrument, search sectors above the ground cannot be made extra large because the pilot can be expected to have difficulty locating a plane in the uncluttered sky. Blank sky is, like the screen used in this test, devoid of any keys or aids which might help to maintain pilot focus at infinity. This situation, which is known as space myopia, has been observed to occur in other aviation situations¹⁸. It is likely therefore that the pilot may find it difficult to locate a plane against the sky or a uniform overcast due to this factor.

5.2 Effect of Target Conspicuousness on Optimum Sector Selection

Target contrast was varied in the runs with both types of backgrounds. As might be expected, the more visible a target, the less effect sector size had on the time required to locate it. Increased target brightness tended to reduce the performance differential between the largest and smallest sectors. Unfortunately, target visibility is a factor over which PWI designers have little control. At reasonably low values of target visibility which might be comparable to real life situations, such as a plane against the ground below, the subject performs rather poorly with

oversized sectors. Therefore, there would seem to be a requirement for incorporation of small sectors in a PWI device.

5.3 Analysis of Effect of Sector Size on Search Time

Reducing the size of the sector to be searched tends to reduce the time required to locate a target within the sector. Figure 5.1 shows a plot of the time below which ninety percent of the observations fall versus sector size. However, it should be noted that the benefit of decreasing sector size below a critical size is marginal or non-existent. Increasing sector sizes above this minimum critical size markedly reduces the subject's ability to locate the target within it.

This critical sector size is roughly $11^\circ \times 11^\circ$ under the conditions of this experiment. The consistency of this conclusion, across all trials under all backgrounds and contrast ratios used, suggests that this size might be optimum under an even wider range of situations. Examinations centered around this sector size in a more realistic PWI situation, possibly a flight test or careful simulation, would certainly be justified.

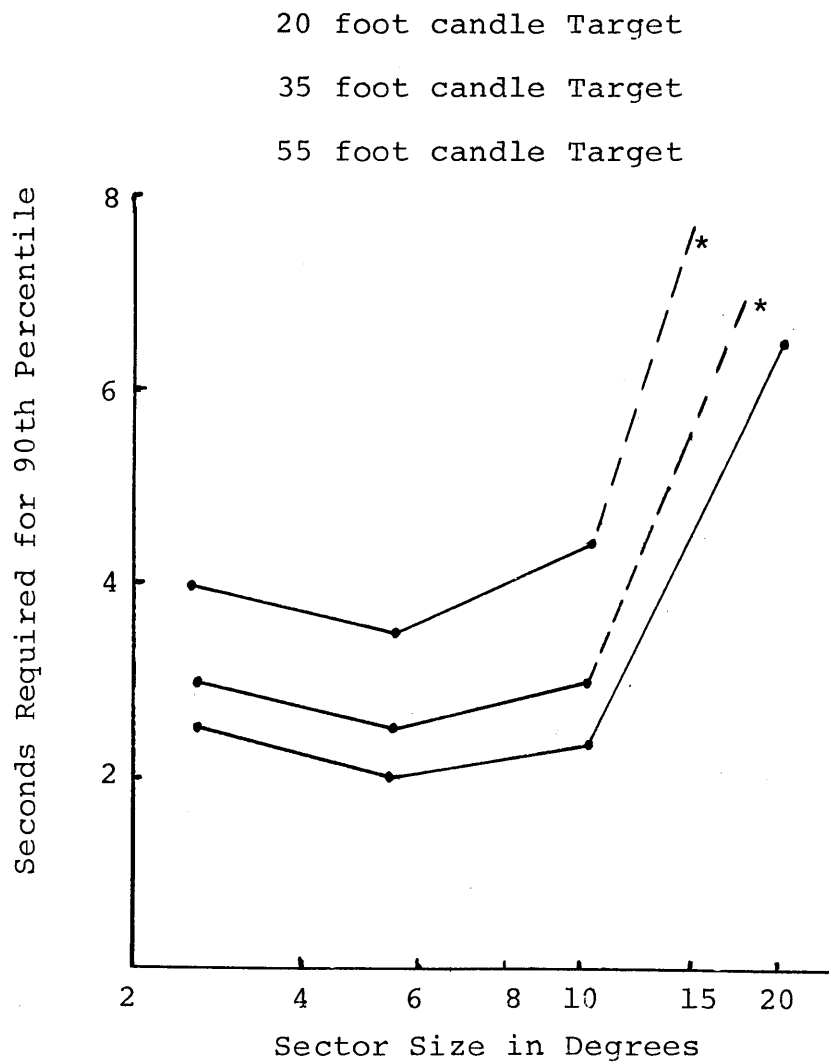

Figure 5.1: High Contrast Background Statistics

* Dashed line indicates that error rate had become so high that 90th percentile was never reached.

5.4 Central Vision Versus Peripheral Vision in a Search Situation

A possible explanation of the uniform performance across a whole range of smaller sector sizes may involve the use of central vision versus peripheral vision during the search. With the larger sectors, the subjects complained of an inability to search such a large area. Generally, they commented that they found themselves searching the same areas of the sector repeatedly. Judging from their performance, many areas also went completely unsearched. In contrast, no one found it at all difficult to locate the actual sector indication on a screen many times the area of the largest sector.

The logical conclusion is that the process by which the target was located differed considerably from the process in which the sector was located. The sector could be easily spotted with peripheral vision while the target generally required the use of the central vision to locate it. Since the area which can be viewed by the central vision is relatively small, it is possible that an effective, rapid search can only be carried out when the area to be searched is no larger than the area covered by the central vision with a single fixation of the eyes or when only a small group of tightly related fixations are required to cover the search region. With the larger sector sizes, the search pattern required numerous fixations across relatively unmarked landscape and allowed inefficiencies to occur. The search moved at random

around the sector missing areas and covering certain areas more than once. In addition, the subject might have attempted to fall back on his peripheral vision as an aid to locating the target. If such an attempt was made, it clearly would be non-productive as the target under most conditions was too small and too dim to locate with this less acute vision.

The implication of this theory is that the sectors should be adjusted to a size which might easily be scanned using the central vision. The results of this experimentation suggest that an $11^{\circ} \times 11^{\circ}$ field of view might very nearly be such an ideal sized area. The dangers of attempting to make do with a larger sector are twofold. First, the pilot will not perform as satisfactorily with such a device. Secondly, since he will no doubt notice the considerable number of alarms for which he can not spot a plane, his trust in the device may be reduced to the point where he will not use it. The later case of an alarm for which the pilot never spots a plane is a sort of false false alarm. An alarm from a plane which is not on a collision course is a false alarm. Device failure may, however, generate an even worst case false alarm where a warning is given when no plane at all is present. If the pilot cannot spot the plane, he may tend to believe that it is the second type of false alarm. Pilot patience with what appears to be device failure will, no doubt, be considerably less than his patience with a device which issues warnings for all nearby aircraft, some

of which may not represent a real threat. It is important to keep sector size small so as to prevent the appearance of device failure, thereby maintaining pilot confidence in the instrument.

5.5 Realistic PWI Devices

A realistic PWI display will be considerably less ideal than was the warning presentation used in this experiment. Sectors will almost certainly not be completely surrounded by a white box. The performance of the pilot will naturally tend to be degraded by a less than perfect display.

The following factors will probably weigh most heavily on the pilots performance:

- (1) Indefinite edges to the sector will probably cause the pilot to view the sector as somewhat larger than it actually is.
- (2) Instrumentation of this device may be subject to flaws or weaknesses. This may cause some uncertainty as to which sector the warning originated from when it is near a sector edge.
- (3) Lack of visually marked edges may cause the pilot's search to wander out of the correct sector.

These factors may modify the optimum sector size. It might be possible to reduce the sector size in order to

compensate for them. However, these effects may be so large as to completely mask any benefits from small sectors.

CHAPTER 6

CONCLUSIONS

This study provides baseline data concerning several important factors which will effect the performance of a PWI device. Because this experiment is an abstraction of a real life situation, some of the conclusions tend to be somewhat more qualitative than quantitative. The data does point to some primary design considerations and provides a basis for a preliminary PWI design. Further, more refined work should be done on a prototype instrument with more realistic simulation or actual flight tests.

The most unexpected conclusion which can be drawn from this study concerns the difficulty subjects encountered in locating targets against the uniform background. An initial guess on a possible cost saving trick for PWI might have been to tie several sectors together so that only a few large sectors covered the sky. Smaller, more refined sectors might then have been employed to cover the ground cluttered field of view. This study indicates that a pilot may have a great deal of difficulty locating a plane in the blank sky. Reasonable PWI resolution would

therefore be required both above and below the horizon.

Since the same sector size was optimum under a wide range of conditions, design of the PWI with identical above and below the horizon resolution is indicated. This optimum sector size was around 10° to 15° on a side. Pilot performance was generally higher at somewhat smaller values of sector size. However, it is likely that the extra cost incurred to reduce the sector to below the 10° to 15° size would not be justified by the marginal increases in performance. Pilot performance with a larger sector size is markedly worse than with the optimum. The 11° sector would therefore appear to be the most cost effective size. Without a cost constraint, a 6° sector is the more ideal size, but this would represent a doubling of sectors for only slight performance increases.

The absolute optimum of 6° corresponds almost exactly to the central vision size. Therefore, the size judged most cost effective can be covered in about four fixations of the eye. The subject would seem to be capable of conducting such a small term scan efficiently. When the sector is as large as 22° , requiring on the order of twenty well placed fixations, his efficiency drops dramatically. A closer study of the exact relationship between scan procedures and search effectiveness might develop a means of enlarging the optimum search area to a more economical size. Such techniques might include differently shaped sectors,

pilot training or scan guides with a single sector. If such a technique could be employed effectively, a considerable savings in PWI cost might be realized.

In summary, this study concludes that a PWI instrument should probably have the following features:

- (1) Equal area sectors throughout the field of view.
- (2) Sectors of between 10° to 15° on a side.

It also recommends that further work be devoted to a more careful study of the exact role of the central vision in a detailed search task. It also recognizes that deviation from conclusions (1) and (2) may be desirable in certain cases due to further considerations. A typical such consideration might be a concentration of PWI resolution into areas of most probable threat.

APPENDIX I

The following instructions were read by each of the subjects before the experiment. A sample table of random numbers is also included.

Instructions

This experiment is designed to test various factors involved in visual search procedures. You will be given two tasks, a primary search task and a secondary background loading task.

Primary task

You will be presented with a series of search situations to be solved. Each of these trials will be similar in nature with certain parameters varied between trials. A single trial will consist of the following:

- 1) An alarm will sound indicating the beginning of the trial.
- 2) An area to be searched will be marked out on the screen by enclosing it with a white square.
- 3) A target to be searched for will be displayed somewhere within the search sector. This target is an elongated triangle which will be pointing either up,down,left, or right.

You are to search the indicated region for the triangle and when you have located it,you should press the hand held button. This portion of the task should be performed with as much speed as possible.

After pressing the hand held button,the target and sector indication will disappear. At this time,you should press the panel button which corresponds to the direction in which the triangle was pointing. Time is not important in this phase of the trial so take your time and press the correct button. Press these buttons firmly so as to assure switch closure. If the projector motor stops without presenting a new trial,the computer is waiting for your response. Repeat your response if you have already pushed the button. If you have not yet responded,respond normally.

Return to the secondary task at this time and await the next alarm.

Note: Failure to respond within 32 sec. after the onset of the alarm is interpreted as a failure to locate the target and the computer will automatically record such and proceed to the next trial. At the end of the 32 seconds,the alarm will be turned off and you should return immediately to the secondary task.

Secondary Task

You are provided with a sheet of numbers. Work from left to right, line by line, performing the following task:

- 1) Mark through chains of 3 increasing digits with a red pen.
- 2) Mark through chains of 3 decreasing digits with a green pen.

Note:

- a) Once a chain of digits has been marked through, they may not be used or incorporated into other chains.
- b) In the case of a conflict where a single digit could be part of either of two different chains, mark the first occurring chain. For example, 25743 contains the chain 257 and 743 but only one of these chains may be marked since they share a digit. Mark the 257 chain.
- c) A 3 digit chain must not be part of a larger chain of four or more digits. For example, 234567.
- d) Ignore the spaces between groups of five digits as these are merely to assist you in keeping track of your place.
- e) Start over at the beginning of each line; do not try to run a chain off the end of one line and onto the beginning of another.

92630	78240	19267	95457	53497	23894	37708	79862	76471	66418
79445	78735	71549	44843	26104	67318	00701	34986	66751	99723
59654	71966	27386	50004	05358	94031	29281	18544	52429	06080
31524	49587	76612	39789	13537	48086	59483	60680	84675	53014
06348	76938	90379	51392	55887	71015	09209	79157	24440	30244
28703	51709	94456	48396	73780	06436	86641	69239	57662	80181
68108	89266	94730	95761	75023	48464	65544	96583	18911	16391
99938	90704	93621	66330	33393	95261	95349	51769	91616	33238
91543	73196	34449	63513	83834	99411	58826	40456	69268	48562
42103	02781	73920	56297	72678	12249	25270	36678	21313	75767
17138	27584	25296	28387	51350	61664	37893	05363	44143	42677
28297	14280	54524	21618	95320	38174	60579	08089	94999	78460
09331	56712	51333	06289	75345	08811	82711	57392	25252	30333
31295	04204	93712	51287	05754	79396	87399	51773	33075	97061
36146	15560	27592	42069	99281	59640	15221	96079	09961	05371
29553	18432	13630	05529	02791	81017	49027	79031	50912	09399
23501	22642	63081	08191	89420	67800	55137	54707	32945	64522
57888	85846	67967	07835	11314	01545	48535	17142	08552	67457
55336	71264	88472	04334	63919	36394	11196	92470	70543	29776
10087	10072	55980	64688	68239	20461	89381	93809	00796	95945
34101	81277	66090	88872	37818	72142	67140	50785	21380	16703
53362	44940	60430	22834	14130	96593	23298	56203	92671	15925
82975	66158	84731	19436	55790	69229	28661	13675	99318	76873
54827	84673	22898	08094	14326	87038	42892	21127	30712	48489
25464	59098	27436	89421	80754	89924	19097	67737	80368	08795
67609	60214	41475	84950	40133	02546	09570	45682	50165	15609
44921	70924	61295	51137	47596	86735	35561	76649	18217	63446
33170	30972	98130	95828	49786	13301	36081	80761	33985	68621
84687	85445	06208	17654	51333	02878	35010	67578	61574	20749
71886	56450	36567	09395	96951	35507	17555	35212	69106	01679
00475	02224	74722	14721	40215	21351	08596	45625	83981	63748
25993	38881	68361	59560	41274	69742	40703	37993	03435	18873
92882	53178	99195	93803	56985	53089	15305	50522	55900	43026
25138	26810	07093	15677	60688	04410	24505	37890	67186	62829
84631	71882	12991	83028	82484	90339	91950	74579	03539	90122
34003	92326	12793	61453	48121	74271	28363	66561	75220	35908
53775	45749	05734	86169	42762	70175	97310	73894	88606	19994
59316	97885	72807	54966	60859	11932	35265	71601	55577	67715
20479	66557	50705	26999	09854	52591	14063	30214	19890	19292
86180	84931	25455	26044	02227	52015	21820	50599	51671	65411
21451	68001	72710	40261	61281	13172	63819	48970	51732	54113
98062	68375	80089	24135	72355	95428	11808	29740	81644	86610
01788	64429	14430	94575	75153	94576	61393	96192	03227	32258
62465	04841	43272	68702	01274	05437	22953	18946	99053	41690
94324	31089	84159	92933	99989	89500	91586	02802	69471	68274
05797	43984	21575	09908	70221	19791	51578	36432	33494	79888
10395	14289	52185	09721	25789	38562	54794	04897	59012	89251
35177	56986	25549	59730	64718	52630	31100	62384	49483	11409
25633	89619	75882	98256	02126	72099	57183	55887	09320	73463
16464	48280	94254	45777	45150	68865	11382	11782	22695	41988

APPENDIX II

The PDP-8 computer program which conducted the experiment is listed with the appropriate data tables and their explanations.

```

*20
0020 0000 START, 0000 / CLEAR ALL D/A LINES
0021 7300 CLA CLL
0022 6552 DAL1
0023 6554 DAL2
0024 6562 DAL3
0025 6564 DAL4
0026 6572 DAL5
0027 6574 DAL6
0030 6472 DAL7
0031 6474 DAL8
0032 6422 DACG
0033 7402 HLT
0034 6046 TLS / SET PRINTER FLAG
0035 7300 CLA CLL
0036 1102 TAD BLANK / CLEAR BLANK STAORAGE TABLES
0037 3010 DCA 10
0040 1103 TAD LENGTH
0041 7041 CIA
0042 3000 DCA 0
0043 3410 DCA I 10
0044 2000 ISZ 0
0045 5043 JMP .-2
0046 7240 CLA CMA
0047 3104 DCA ANSWER
0050 1110 TAD C1
0051 3100 DCA VECTOR / SET UP INITIAL VALUES
0052 1111 TAD C2
0053 3101 DCA SP
0054 4471 JMS I SSTEPS
0055 4466 JMS I SNEXT
0056 7300 CLA CLL
0057 3104 DCA ANSWER

```

/MAIN CONTROL ROUTINE FOR CONDUCTING TEST

```

0060 4467 CONTRL, JMS I STEST
0061 4466 JMS I SNEXT
0062 4472 JMS I SSTAT
0063 4471 JMS I SSTEPS
0064 4473 JMS I PRINT
0065 5060 JMP CONTRL
0066 0600 SNEXT, NEXT
0067 0705 STEST, TEST
0070 0400 SSTEPP, STEPP
0071 0411 SSTEPS, STEPS
0072 1000 SSTAT, STAT
0073 0434 PRINT, PRNT

```

/ PRIMARY CONSTANTS SECTION

		*100		
0100	3000	VECTOR,	3000	/ POINTER TO TABLE OF PROJECTOR POINT
0101	3200	SP,	3200	/ POINTER TO SLIDE INFORMATION
0102	3377	BLANK,	3377	/ START FOR BLANK STORAGE FOR DATA
0103	3400	LENGTH,	3400	/ LENGTH OF BLANK STORAGE AREA
0104	0000	ANSWER,	0000	/ EVALUATION OF ACCURACY CODE
0105	0000	TIME1,	0000	/ LEAST SIGNIFICANT BITS OF TIME OF
0106	0000	TIME2,	0000	/ MOST SIGNIFICANT BITS
0107	3777	SSW,	3777	/ DIRECTION OF SLIDE MOTION CODE
0110	3000	C1,	3000	/ INITIAL VECTOR VALUE
0111	3200	C2,	3200	/ INITIAL SP VALUE
0112	2000	TP,	2000	/ POINTERS TO TEST REPORT GEN INFO
0113	0000	DISP,	0	/ PROJECTOR DISP FROM CENTER

```

*200
0200 0000 TYPE, 0000 / TYPE CHARACTER
0201 6041 TSF / IN THE ACCUMULATOR
0202 5201 JMP .-1
0203 6046 TLS
0204 7200 CLA
0205 2200 ISZ TYPE
0206 5600 JMP I TYPE
0207 0000 CRLF, 0000 / TYPE CARRIAGE RETURN
0210 7300 CLA CLL / LINE FEED
0211 1213 TAD .+2
0212 4200 JMS TYPE
0213 0215 215
0214 1216 TAD .+2
0215 4200 JMS TYPE
0216 0212 212
0217 2207 ISZ CRLF
0220 5607 JMP I CRLF
0221 0000 DIGIT, 0000 / TYPE A SINGLE DIGIT
0222 2221 ISZ DIGIT
0223 7440 SZA
0224 5227 JMP .+3
0225 7420 SNL
0226 5621 JMP I DIGIT
0227 1231 TAD .+2
0230 4200 JMS TYPE
0231 0260 260
0232 7120 CLL CML

0233 5621 JMP I DIGIT

0234 0000 SPACE, 0000 / TYPE A SPACE
0235 2234 ISZ SPACE
0236 7200 CLA
0237 1241 TAD .+2
0240 4200 JMS TYPE
0241 0240 240
0242 5634 JMP I SPACE
0243 0000 POINT, 0000 / TYPE DECIMAL
0244 2243 ISZ POINT
0245 7200 CLA / POINT
0246 1250 TAD .+2
0247 4200 JMS TYPE
0250 0256 256
0251 5643 JMP I POINT
0252 0000 TRIDIG, 0000 / TYPE THREE DIGIT SEQUENCE OF DIG
0253 2252 ISZ .-1
0254 7421 MQL
0255 7010 RAR
0256 3266 DCA TRI1
0257 7407 DVI
0260 0144 144
0261 3303 DCA TRI2

```

0262	1266		TAD TRI1		
0263	7004		RAL		
0264	7501		MQA		
0265	4221		JMS DIGIT		
0266	0000	TRI1,	0		
0267	7200		CLA		
0270	1303		TAD TRI2		
0271	7421		MQL		
0272	7010		RAR		
0273	3266		DCA TRI1		
0274	7407		DVI		
0275	0012		12		
0276	3303		DCA TRI2		
0277	1266		TAD TRI1		
0300	7004		RAL		
0301	7501		MQA		
0302	4221		JMS DIGIT		
0303	0000	TRI2,	0		
0304	7200		CLA		
0305	1303		TAD TRI2		
0306	4221		JMS DIGIT		
0307	0000		0		
0310	5652		JMP I TRIDIG		
0311	0000	STRING,	0000		/ TYPE STRING OF CHAR
0312	2311		ISZ	.-1	
0313	3010		DCA	10	/ STARTING ADDRESS IN
0314	1410		TAD I	10	/ STRING TERMINATED B
0315	7450		SNA		
0316	5711		JMP I	STRING	
0317	4720		JMS I	.-1	
0320	0200		TYPE		
0321	5314		JMP	.-5	

0400	0000	*400	0000		/ SELECT NEXT POINTER
0401	2100	STEPP,	ISZ	VECTOR	
0402	7300		CLL CLA		
0403	1500		TAD I	VECTOR	
0404	7440		SZA		
0405	5600		JMP I	STEPP	
0406	1110		TAD	C1	
0407	3100		DCA	VECTOR	
0410	5600		JMP I	STEPP	
0411	0000	STEPS,	0000		/ SET UP POINTERS
0412	7300		CLA CLL		/ TO NEXT SLIDE
0413	1101		TAD	SP	
0414	1233		TAD	DIR	
0415	3101		DCA	SP	
0416	1101		TAD	SP	
0417	1233		TAD	DIR	
0420	3000		DCA	Ø	
0421	1400		TAD I	Ø	
0422	7440		SZA		/ MAKE SURE NEXT STEP
0423	5611		JMP I	STEPS	/ WILL NOT BE OFF END
0424	1107		TAD	SSW	/ OF LIST
0425	7041		CIA		
0426	3107		DCA	SSW	
0427	1233		TAD	DIR	
0430	7041		CIA		
0431	3233		DCA	DIR	/ IF SO TURN ARROUND
0432	5611		JMP I	STEPS	/ DIRECTION
0433	0002	DIR,	2		
0434	0000	PRNT,	0000		
0435	7300		CLA CLL		/ PRINT REPORT IF LEF
0436	7404		OSR		/ SWITCH SET
0437	7004		RAL		
0440	7430		SZL		
0441	4643		JMS I	REPORT	
0442	5634		JMP I	PRNT	
0443	1200	REPORT,	1200		

```

*600
0600 0000 NEXT, 0000 / POSITION PROJECTOR ROUTINE
0601 6454 CLAF / CLEAR ANALOG FLAG
0602 6461 SNAF / WAIT TILL FLAG SET AGAIN
0603 7410 SKP
0604 5202 JMP .-2
0605 4263 JMS ASK / CHECK 4 BUTTONS FOR RESPONCE
0606 6541 ADCC / READ PROJECTOR POSITION
0607 6544 ADIC
0610 6532 ADCV
0611 6531 ADSF
0612 5211 JMP .-1
0613 7300 CLA CLL
0614 6534 ADRB
0615 7041 CIA / MAKE NUMBER MINUS
0616 1500 TAD I VECTOR / AC NOW EQUAL DESIRED POS. MIN
0617 0221 AND .+2 / DISCARD LEAST SIGNIFICANT BITS
0620 7410 SKP
0621 7740 7740
0622 7440 SZA / SKIP IF IN CORRECT POSITION
0623 5253 JMP MOVE
0624 7200 CLA / STOP MVEMENT
0625 6552 DAL1
0626 6551 DACX
0627 1104 TAD ANSWER
0630 7450 SNA
0631 5201 JMP NEXT+1
0632 7300 CLA CLL / DEPOSIT DISPLACEMENT
0633 1500 TAD I VECTOR
0634 7413 SHL
0635 0005 5
0636 0247 AND NX1
0637 3113 DCA DISP
0640 4650 JMS I NX2 / INCREMENT TO NEXT POSIITION
0641 2252 ISZ NXB
0642 5201 JMP NEXT+1
0643 7300 CLA CLL
0644 1251 TAD NXC
0645 3252 DCA NXB
0646 5600 JMP I NEXT
0647 0700 NX1, 0700 / MASK FOR DISP GENERATION
0650 0400 NX2, STEPP / ADD OF STEP ROUTINE
0651 7774 NXC, -4 / MINUS COUNT OF STEPS TO BE TR
0652 7774 NXB, -4 / MINUS NO. OF STEPS LEFT
0653 7510 MOVE, SPA / PUT OUT +10 VOLTS
0654 5257 JMP .+3 / IF AC POSITIVE
0655 7350 CLA CMA CLL RAR / PUT 3777 IN AC
0656 7410 SKP
0657 7330 CLA CLL CML RAR / IF NEG AC PUT 4000 IN AC
0660 6552 DAL1 / LOAD ANALOG
0661 6551 DACX / CONVERT TO ANALOG
0662 5201 JMP NEXT+1
0663 0000 ASK, 0000 / THIS ROUTINE

```

0664	7300	CLA CLL		/ CHECKS SENSE LINES
0665	1104	TAD	ANSWER	/ IF ANSWER TO QUESTION
0666	7440	SZA		/ IS REQUIRED IF NOT
0667	5663	JMP I	ASK	/ REQUIRED (ALREADY ANSWERED)
0670	6435	LASL		/ RETURN DOING NOTHING
0671	7440	SZA		
0672	7410	SKP		
0673	5663	JMP I	ASK	
0674	0501	AND I	SP	
0675	7440	SZA		
0676	5302	JMP	•+4	
0677	7340	CLA CLL CMA		
0700	3104	DCA	ANSWER	
0701	5663	JMP I	ASK	
0702	7324	CLA CLL CML RAL		
0703	3104	DCA	ANSWER	
0704	5663	JMP I	ASK	

0705	0000	TEST,	0000		/ RUN A NEW TRIAL
0706	7350		STA CLL RAR		
0707	6564		DAL4		
0710	6561		DACY		
0711	7200		CLA		/ SET CLOCK TO ZERO
0712	3105		DCA	TIME1	
0713	3106		DCA	TIME2	
0714	6454	COUNT,	CLAF		/ WAIT FOR NEXT CYCLE
0715	6461		SNAF		
0716	7410		SKP		
0717	5315		JMP	.-2	
0720	2105		ISZ	TIME1	/ COUNT TIME UNITS
0721	7410		SKP		
0722	2106		ISZ	TIME2	
0723	6545		ADCC	ADIC	/ GET TO A-D 2
0724	6544		ADIC		
0725	6532		ADCV		/ CONVERT
0726	6531		ADSF		/ IF IT HAS GONE POSITIVE
0727	5326		JMP	.-1	/ HE HAS PUSHED BUTTON
0730	7300		CLA	CLL	
0731	6534		ADRB		/ RUN OVER
0732	7510		SPA		/ IF NEGATIVE LOOP ANOTHER
0733	5314		JMP	COUNT	
0734	4360		JMS	TIME	
0735	7200		CLA		/ IF OVER TURN OFF EVERYT
0736	6564		DAL4		/ SHUT ALARM OFF
0737	1107		TAD	SSW	
0740	6562		DAL3		/ CHANGE TO BLANK SLIDE
0741	6561		DACY		
0742	7300		CLA	CLL	
0743	1357		TAD	TAU	/ WAIT FOR SLIDE TO CHANGE
0744	6454		CLAF		
0745	6461		SNAF		
0746	7410		SKP		
0747	5345		JMP	.-2	
0750	7001		IAC		
0751	7420		SNL		
0752	5344		JMP	.-6	/ NOW OPEN SWITCH
0753	7200		CLA		/ WHEN SLIDE HAS CHANGED
0754	6562		DAL3		
0755	6561		DACY		
0756	5705		JMP	I TEST	
0757	6260	TAU,	6260		/ MINUS NUMBER OF TICKS A
					/ ALLOWED FOR SLIDE CHANGE
0760	0000	TIME,	0000		/ DISPLAY TIME ON DVM
0761	7200		CLA		/ CLEAR AC
0762	1105		TAD	TIME1	
0763	7421		MQL		/ LOAD 24 BIT TIME REG
0764	1106		TAD	TIME2	/ INTO AC-MQ
0765	7415		ASR		
0766	0001		1		
0767	7300		CLA	CLL	
0770	7405		MUY		

0771 6431
0772 6554
0773 6551
0774 5760

6431
DAL2
DACX
JMP I TIME

/ CONVERT TO PROPER RA■
/ AND PUT NUMBER OUT T■

1000	0000	*800	0000	/ ROUTINE TO COMPILE STATISTICS
1001	7300	STAT,	CLA CLL	
1002	1101	TAD	SP	/ SET UP INDEX TO DATA AREA
1003	7001	IAC		
1004	3374	DCA	INDEX	
1005	1774	TAD I	INDEX	
1006	1113	TAD	DISP	
1007	3374	DCA	INDEX	
1010	2774	ISZ I	INDEX	
1011	1104	TAD	ANSWER	/ THEN FILL OUT WHETHER GOOD
1012	7510	SPA		/ OR BAD TRIAL
1013	5222	JMP	+.7	
1014	2374	ISZ	INDEX	/ IF GOOD COUNT AS GOOD
1015	2774	ISZ I	INDEX	
1016	2374	ISZ	INDEX	
1017	7300	CLA CLL		
1020	3104	DCA	ANSWER	
1021	5230	JMP	+.7	
1022	2374	ISZ	INDEX	/ IF BAD COUNT AS BAD AND
1023	2374	ISZ	INDEX	/ RETURN
1024	2774	ISZ I	INDEX	
1025	7300	CLA CLL		
1026	3104	DCA	ANSWER	
1027	5600	JMP I	STAT	
1030	2374	ISZ	INDEX	/ NOW COMPUTE
1031	7300	CLA CLL		/ SUM OF TIME
1032	1774	TAD I	INDEX	
1033	1105	TAD	TIME1	
1034	3774	DCA I	INDEX	
1035	2374	ISZ	INDEX	
1036	7430	SZL		
1037	7101	CLL IAC		
1040	1106	TAD	TIME2	
1041	1774	TAD I	INDEX	
1042	3774	DCA I	INDEX	
1043	2374	ISZ	INDEX	/ NOW COMPUTE SQUARE
1044	1105	TAD	TIME1	/ AND ADD TO SUMM OF
1045	7421	MQL		/ SQUARES
1046	1105	TAD	TIME1	
1047	3251	DCA	+.2	
1050	7405	MUY		
1051	0000	000		
1052	3371	DCA	Q2	
1053	7501	MQA		
1054	3370	DCA	Q1	
1055	1105	TAD	TIME1	
1056	7421	MQL		
1057	1106	TAD	TIME2	

1060	7104	CLL	RAL	
1061	3263	DCA		•+2
1062	7405	MUY		
1063	0000	000		
1064	3372	DCA		Q3
1065	7501	MQA		
1066	1371	TAD		Q2
1067	3371	DCA		Q2
1070	7430	SZL		
1071	7101	CLL	IAC	
1072	1372	TAD		Q3
1073	3372	DCA		Q3
1074	1106	TAD		TIME2
1075	7421	SQL		
1076	1106	TAD		TIME2
1077	3301	DCA		•+2
1100	7405	MUY		
1101	0000	000		
1102	7430	SZL		
1103	7101	IAC	CLL	
1104	3373	DCA		Q4
1105	7100	CLL		
1106	7501	MQA		
1107	1372	TAD		Q3
1110	3372	DCA		Q3
1111	7430	SZL		
1112	2373	ISZ		Q4
1113	7300	CLL	CLA	

1114	1370	TAD	Q1	/ NOW THAT SQUARE IS CALCUL
1115	1774	TAD I	INDEX	/ ADD TO SUMM
1116	3774	DCA I	INDEX	
1117	7430	SZL		
1120	7101	CLL	IAC	
1121	1371	TAD	Q2	
1122	2374	ISZ	INDEX	
1123	1774	TAD I	INDEX	
1124	3774	DCA I	INDEX	
1125	2374	ISZ	INDEX	
1126	7430	SZL		
1127	7101	CLL	IAC	
1130	1372	TAD	Q3	
1131	1774	TAD I	INDEX	
1132	3774	DCA I	INDEX	
1133	2374	ISZ	INDEX	
1134	7430	SZL		
1135	7101	CLL	IAC	
1136	1373	TAD	Q4	
1137	1774	TAD I	INDEX	
1140	3774	DCA I	INDEX	
1141	7300	CLA	CLL	/ NOW DETERMINE WHICH BLOC

1142	1105	TAD	TIME1	/ TRIAL SHOULD BE ADDED TO
1143	7421	MQL		
1144	1106	TAD	TIME2	
1145	7413	SHL		
1146	0002	002		
1147	7001	IAC		
1150	3370	DCA	Q1	
1151	1370	TAD	Q1	
1152	7041	CIA		
1153	1367	TAD	MAXSIZ	
1154	7500	SMA		
1155	5361	JMP	+.4	
1156	7300	CLL CLA		
1157	1367	TAD	MAXSIZ	
1160	5363	JMP	+.3	
1161	7300	CLL CLA		
1162	1370	TAD	Q1	
1163	1374	TAD	INDEX	
1164	3374	DCA	INDEX	
1165	2774	ISZ I	INDEX	
1166	5600	JMP I	STAT	/ FINISHED RETURN
1167	0067	MAXSIZ,	67	
1170	0000	Q1,	0	
1171	0000	Q2,	0	
1172	0000	Q3,	0	
1173	0000	Q4,	0	
1174	1174	INDEX ,	0	

ANSWER	0104
ASK	0663
BLANK	0102
CONTRL	0060
COUNT	0714
CRLF	0207
C1	0110
C2	0111
DIGIT	0221
DIR	0433
DISP	0113
INDEX	1174
LENGTH	0103
MAXSIZ	1167
MOVE	0653
NEXT	0600
NXB	0652
NXC	0651
NX1	0647
NX2	0650
POINT	0243
PRINT	0073
PRNT	0434
Q1	1170
Q2	1171
Q3	1172
Q4	1173
REPORT	0443
SNEXT	0066
SP	0101
SPACE	0234
SSTAT	0072
SSTEPP	0070
SSTEPS	0071
SSW	0107
START	0020
STAT	1000
STEPP	0400
STEPS	0411
STEST	0067
STRING	0311
TAU	0757
TEST	0705
TIME	0760
TIME1	0105
TIME2	0106
TP	0112
TRIDIG	0252
TRI1	0266
TRI2	0303
TYPE	0200
VECTOR	0100

```

*1200      / ROUTINE TO REPORT RESULTS
1200  0000  REPORT, 0000      / PRINT REPORT
1201  7300  CLA CLL      / SET UP INDEX
1202  1112  TAD TP / TO RPORT TABLE
1203  7041  CIA
1204  7040  CMA
1205  3016  DCA INDEX1

1206  1416  LOOP, TAD I INDEX1
1207  7450  SNA
1210  5600  JMP I REPORT
1211  4612  JMS I .+1
1212  0311  STRING      / TYPE HEADING

1213  1416  TAD I INDEX1 / SET UP INDEX
1214  7041  CIA
1215  7040  CMA
1216  3017  DCA INDEX

1217  4620  S1, JMS I .+1 / PRINT FIRST STATISTIC
1220  0207  CRLF
1221  7200  CLA
1222  1234  TAD T1
1223  4624  JMS I .+1
1224  0311  STRING
1225  7200  CLA
1226  1417  TAD I INDEX
1227  4630  JMS I .+1
1230  0252  TRIDIG
1231  4632  JMS I .+1
1232  0207  CRLF
1233  5256  JMP S2

1234  1234  T1, .
1235  0316  316
1236  0317  317 / "NO. OF TRIALS = "
1237  0256  256
1240  0240  240
1241  0317  317
1242  0306  306
1243  0240  240
1244  0324  324
1245  0322  322
1246  0311  311
1247  0301  301
1250  0314  314
1251  0323  323
1252  0240  240
1253  0275  275
1254  0240  240
1255  0000  000

```

INDEX=17

INDEX1=16

1256	7300	S2, CLA CLL	/ TYPE NO. OF VALID TRIALS
1257	1417	TAD I INDEX	
1260	3331	DCA NUMBER	
1261	1331	TAD NUMBER	
1262	4663	JMS I .+1	
1263	0252	TRIDIG	
1264	2017	ISZ INDEX	
1265	7300	CLA CLL	
1266	1276	TAD T2	
1267	4670	JMS I .+1	
1270	0311	STRING	
1271	7300	CLA CLL	
1272	1331	TAD NUMBER	/ IF NO VALID TRIALS REPORT FINISHED
1273	7440	SZA	
1274	5317	JMP S4	
1275	5206	JMP LOOP	
1276	1276	T2, .	
1277	0240	240	
1300	0326	326	/ " VALID TRIALS "
1301	0301	301	
1302	0314	314	
1303	0311	311	
1304	0304	304	
1305	0240	240	
1306	0324	324	
1307	0322	322	
1310	0311	311	
1311	0301	301	
1312	0314	314	
1313	0323	323	
1314	0215	215	
1315	0212	212	
1316	0000	000	
1317	7300	S4, CLL CLA	/ PRINT MEAN =
1320	1357	TAD T4	
1321	4722	JMS I .+1	
1322	0311	STRING	
1323	1417	TAD I INDEX	/ CALCULATE MEAN
1324	7421	MQL	
1325	1417	TAD I INDEX	
1326	7415	ASR	
1327	0003	3	
1330	7407	DVI	
1331	0000	NUMBER, 0	/ FORM OF MEAN
1332	7701	CLA MQA	/ FIRST 6 BITS WHOLE SEC.
1333	3356	DCA MEAN	/ SECOND 6 BITS FRACTION
1334	1356	TAD MEAN	/ OF SECOND
1335	7100	CLL	/ PRINT INTERGER
1336	7417	LSR	/ PART
1337	0005	5	
1340	4741	JMS I .+1	
1341	0252	TRIDIG	

1342	4743	JMS I .+1	
1343	0243	POINT	/ PRINT DECIMAL POINT
1344	7300	CLA CLL	
1345	1356	TAD	MEAN
1346	7417	LSR	
1347	0005	5	
1350	7405	MUY	/ PRNT FRACTIN
1351	1750	1750	
1352	7120	CLL CML	
1353	4754	JMS I .+1	
1354	0252	TRIDIG	
1355	4377	JMS	S6
1356	0000	MEAN,	0000

1357	1357	T4, .	
1360	0215	215	
1361	0212	212	/ MEAN =
1362	0315	315	
1363	0305	305	
1364	0301	301	
1365	0316	316	
1366	0240	240	
1367	0275	275	
1370	0240	240	
1371	0000	000	

```

*1377
1377 7300 S6, CLA CLL /TYPE VARIANCE
1400 1367 TAD T6
1401 4602 JMS I .+1
1402 0311 STRING
1403 7300 CLA CLL / CALCULATE VARIANCE
1404 1366 TAD D1ADD
1405 3010 DCA 10
1406 1365 TAD NM4
1407 3007 DCA 7 / MOVE SUM OF SQUARES
1410 1417 TAD I INDEX
1411 3410 DCA I 10 / TO D1 THRU D4
1412 2007 ISZ 7
1413 5210 JMP .-3
1414 1364 TAD D4 / NOW DIVIDE BY NUMBER
1415 7421 MQL
1416 1757 TAD I NUMB
1417 3221 DCA .+2
1420 7407 DVI
1421 0000 TMP, 0
1422 3221 DCA TMP
1423 7501 MQA
1424 3364 DCA D4
1425 1363 TAD D3
1426 7421 MQL
1427 1757 TAD I NUMB
1430 3233 DCA .+3
1431 1221 TAD TMP
1432 7407 DVI
1433 0000 0
1434 3221 DCA TMP
1435 7501 MQA
1436 3363 DCA D3
1437 1362 TAD D2
1440 7421 MQL
1441 1757 TAD I NUMB
1442 3245 DCA .+3
1443 1221 TAD TMP
1444 7407 DVI
1445 0000 0
1446 3221 DCA TMP
1447 7501 MQA
1450 3362 DCA D2
1451 1361 TAD D1
1452 7421 MQL
1453 1757 TAD I NUMB
1454 3257 DCA .+3
1455 1221 TAD TMP
1456 7407 DVI
1457 0000 0
1460 7701 CLA MQA
1461 3361 DCA D1
1462 7300 CLA CLL

```

1463	1362	TAD	D2	/ NOW THAT DIVISION IS
1464	7421	SQL		/ DONE REDUCE TO CORRECT
1465	1363	TAD	D3	
1466	7413	SHL		/ FORM
1467	0003	3		
1470	3364	DCA	D4	
1471	1361	TAD	D1	
1472	7421	SQL		
1473	1362	TAD	D2	
1474	7413	SHL		
1475	0003	3		
1476	3363	DCA	D3	/ D4 CONTAINS INTERGER SEC.
1477	1760	TAD	I AVE	/ D3 CONTAINS FRACTION
1500	7421	SQL		
1501	1760	TAD	I AVE	/ GET MEAN SQUARED
1502	3304	DCA	+.2	
1503	7405	MUY		
1504	0000	0		
1505	7140	CMA	CLL	
1506	3362	DCA	D2	
1507	7501	MQA		
1510	7041	CIA		
1511	7430	SZL		/ PUT IN D2 AND D1
1512	2362	ISZ	D2	/ (X**2/N)-M**2
1513	7100	CLL		
1514	1363	TAD	D3	
1515	3361	DCA	D1	
1516	1362	TAD	D2	
1517	7430	SZL		
1520	7101	CLL	IAC	
1521	1364	TAD	D4	
1522	3362	DCA	D2	
1523	7300	CLL	CLA	/ PRIN T VARIANCE
1524	1362	TAD	D2	
1525	7421	SQL		
1526	7407	DVI		/ DIGITS IN EXCESS OF 999
1527	1750	1750		
1530	3362	DCA	D2	
1531	7501	MQA		
1532	7100	CLL		
1533	7450	SNA		
1534	5340	JMP	+.4	
1535	4736	JMS	I .+1	
1536	0252	TRIDIG		
1537	7200	CLA		
1540	1362	TAD	D2	
1541	4742	JMS	I .+1	
1542	0252	TRIDIG		
1543	4744	JMS	I .+1	
1544	0243	POINT		/ FINISH INTERGER PART / THEN PUT OUT POINT
1545	7200	CLA		
1546	1361	TAD	D1	
1547	7421	SQL		

1550	7405	MUY
1551	1750	1750
1552	7120	CLL CML
1553	4754	JMS I .+1
1554	0252	TRIDIG
1555	5756	JMP I .+1
1556	1620	S10
1557	1331	NUMB, NUMBER
1560	1356	AVE, MEAN
1561	0000	D1, 0
1562	0000	D2, 0
1563	0000	D3, 0
1564	0000	D4, 0
1565	7774	NM4, -4
1566	1560	D1ADD, D1-1
1567	1567	T6, .
1570	0215	215
1571	0212	212
1572	0326	326
1573	0301	301
1574	0322	322
1575	0256	256
1576	0240	240
1577	0275	275
1600	0240	240
1601	0000	000

*1620

1620	7300	S10, CLA CLL	/ PRINT DISTRIBUTION
1621	1275	TAD T10	
1622	4623	JMS I .+1	
1623	0311	STRING	
1624	7300	CLA CLL	
1625	1273	TAD N54	
1626	3000	DCA 0	
1627	3001	DCA 1	
1630	7300	S11, CLL CLA	
1631	1417	TAD I INDEX	
1632	7450	SNA	
1633	5264	JMP SKIP	
1634	3003	DCA 3	
1635	1001	TAD 1	
1636	7417	LSR	
1637	0000	0	
1640	4641	JMS I .+1	
1641	0252	TRIDIG	
1642	4643	JMS I .+1	
1643	0243	POINT	
1644	1001	TAD 1	
1645	7010	RAR	
1646	7200	CLA	
1647	7430	SZL	
1650	1274	TAD N5	
1651	7120	CLL CML	

1652	4653	JMS I	+.1	
1653	0221	DIGIT		
1654	4655	JMS I	+.1	
1655	0234	SPACE		
1656	7300	CLA CLL		
1657	1003	TAD	3	
1660	4661	JMS I	+.1	
1661	0252	TRIDIG		
1662	4663	JMS I	+.1	
1663	0207	CRLF		
1664	2000	SKIP,	ISZ	0
1665	7410	SKP		
1666	5271	JMP	+.3	
1667	2001	ISZ	1	
1670	5230	JMP	S11	
1671	5672	JMP I	+.1	
1672	1206	LOOP		
1673	7711	N54,	-67	
1674	0005	N5,	5	

1675	1675	T10, .
1676	0212	212
1677	0212	212
1700	0215	215
1701	0212	212
1702	0323	323
1703	0305	305
1704	0303	303
1705	0256	256
1706	0240	240
1707	0326	326
1710	0323	323
1711	0256	256
1712	0240	240
1713	0306	306
1714	0322	322
1715	0305	305
1716	0321	321
1717	0256	256
1720	0215	215
1721	0212	212
1722	0212	212
1723	0000	000

CRLF=207
POINT=243
SPACE=234
STRING=311
TP=112
TRIDIG=252
DIGIT=221

AVE	1560
CRLF	0207
DIGIT	0221
D1	1561
D1ADD	1566
D2	1562
D3	1563
D4	1564
INDEX	0017
INDEX1	0016
LOOP	1206
MEAN	1356
NM4	1565
NUMB	1557
NUMBER	1331
N5	1674
N54	1673
POINT	0243
REPORT	1200
SKIP	1664
SPACE	0234
STRING	0311
S1	1217
S10	1620
S11	1630
S2	1256
S4	1317
S6	1377
TMP	1421
TP	0112
TRIDIG	0252
T1	1234
T10	1675
T2	1276
T4	1357
T6	1567

/ PATCH TO WORKING PORTION OF PROGRAM ALLOWS SYSTEM
 / TO SCORE A FAILURE AFTER 32 SEC. WITH NO RESPONCE.

*714

0714 4716 JMS I .+2 / REPLACE CLOCK WAIT
 0715 7410 SKP
 0716 0500 ALARM / WITH TIME LIMIT PLUS
 0717 7000 NOP / CLOCK TICKER

*500

0500 0000 ALARM, 0000 / CHECK TOO SEE THAT 32
 0501 7300 CLA CLL / NOT EXCEEDED
 0502 1106 TAD TIME2
 0503 1322 TAD NM32
 0504 7420 SNL
 0505 5315 JMP CONT
 0506 7340 CLA CLL CMA
 0507 3104 DCA ANSWER
 0510 7300 CLA CLL
 0511 6564 DAL4
 0512 6561 DACY
 0513 5714 JMP I .+1
 0514 0734 ENDIT
 0515 6454 CONT, CLAF
 0516 6461 SNAF
 0517 7410 SKP
 0520 5316 JMP .-2
 0521 5700 JMP I ALARM
 0522 7770 NM32, -10
 TIME2=106
 ANSWER=104
 ENDIT=734

ALARM	0500
ANSWER	0104
CONT	0515
ENDIT	0734
NM32	0522
TIME2	0106

Report Control Table

This table governs the order in which data blocks are to be printed by the report generator. Each entry is a double word. The first word contains the address of the starting location of a string of 7 bit ASCII characters. The second word contains the location of the first word of the data block. The string of ASCII will be printed then the report will be typed allowing a descriptor to precede the report. The last entry of the table must be zero. The program will generate a series of reports starting with the first entry and progressing until the zero entry is reached. Origin of the table is location 2000_8 . The character strings must consist of 7 bits full ASCII, right justified, one character per word and terminated by a zero word. Both table and string storage must fit entirely within the 2000_8 to 2777_8 block of storage.

/ REPORT CONTROL FOR CONSOLIDATED TABLES

		*2000
2000	0000	0000
2001	0000	0000
2002	2200	XS
2003	5300	5300
2004	2205	S
2005	3400	3400
2006	2211	M
2007	4100	4100
2010	2215	L
2011	4600	4600
2012	0000	0000
2013	0000	0000
		*2200
2200	0215	XS, 215
2201	0212	212
2202	0330	330
2203	0323	323
2204	0000	000
2205	0215	S, 215
2206	0212	212
2207	0323	323
2210	0000	000
2211	0215	M, 215
2212	0212	212
2213	0315	315
2214	0000	000
2215	0215	L, 215
2216	0212	212
2217	0314	314
2220	0000	000

L	2215
M	2211
S	2205
XS	2200

Slide Tray Table

This table contains all the information concerning the slides required by the program. In addition, the appropriate data area for each slide is given.

Entries in this table are each two words long. The first word contains the code corresponding to a proper switch response by the subject. For this experiment, possible codes were either 1, 2, 4 or 8 corresponding to right, up, left and down. The second word contains the starting address of the data block set aside for this slide or type of slide. This address will be modified by the amount specified in the vectoring table to arrive at a specific 64 word block of core. The statistics for this trial will then be added to accumulated statistics already resident there.

The first double word entry in this table is zero and the last double word entry is zero. The remaining entries correspond to the slides in the tray with early slides in the tray coming first in the table. Origin of the table is 3200_8 and the length is no more than 200_8 .

/ SLIDE TABLE GIVES PROPER SWITCH RESPONCE & DATA AREA

*3200

3200	0000	0
3201	0000	0
3202	0001	1
3203	4100	4100
3204	0002	2
3205	4600	4600
3206	0010	10
3207	5300	5300
3210	0001	1
3211	4100	4100
3212	0010	10
3213	4100	4100
3214	0004	4
3215	4600	4600
3216	0010	10
3217	3400	3400
3220	0004	4
3221	4600	4600
3222	0001	1
3223	5300	5300
3224	0004	4
3225	4100	4100
3226	0010	10
3227	5300	5300
3230	0004	4
3231	3400	3400
3232	0001	1
3233	4100	4100
3234	0002	2
3235	3400	3400
3236	0004	4
3237	4600	4600
3240	0002	2
3241	5300	5300
3242	0002	2
3243	3400	3400
3244	0010	10
3245	4600	4600
3246	0001	1
3247	3400	3400
3250	0002	2
3251	5300	5300
3252	0000	0
3253	0000	0000

Vectoring Table

This table describes each point on the screen to which the projector will be directed. The program will start at the top of the table and point the projector at each point listed in the table until the table is exhausted. When this happens, the program will start again at the top. Four vectoring commands are used for each trial, 3 to provide the intermediate positions of the random walk and 1 to provide the final position. If the table is not an even multiple of 4 but is divisible by 4 with a remainder of 1, the table will precess such that all the table entries will be used to point the project for a trial once every four times through the table.

The point on the screen to which the projector is to be directed is given by the bits 1-6 of the entry. 000001 points to the extreme right and 111111 points to the extreme left.

Bits 9-11 of the entry designate the azimuth grouping of this vectoring command. This number is used to modify the data address given in the slide table. In a sense, the data area can be viewed as a two dimensional array with each item in the array being the data for a single type of trial. The slide table then gives the first index and the vectoring table the second. Storage requirements for the data are 64 words of core for every cross point used.

Azimuth groupings should be assigned numbers between 0 and 7 with 0 being used first and 7 last.

Bits 0, 7, and 8 of the word must be zero. The last entry in the table must be all zero.

/ VECTORING TABLE WITH SCREEN DIVISION
*3000

3000	2000	2000
3001	2100	2100
3002	0600	0600
3003	2500	2500
3004	2200	2200
3005	0600	0600
3006	2200	2200
3007	1400	1400
3010	1100	1100
3011	0400	0400
3012	1200	1200
3013	0400	0400
3014	1200	1200
3015	0600	0600
3016	1000	1000
3017	0400	0400
3020	0200	0200
3021	0600	0600
3022	1200	1200
3023	1100	1100
3024	1500	1500
3025	2100	2100
3026	2500	2500
3027	2600	2600
3030	3200	3200
3031	3600	3600
3032	3100	3100
3033	3400	3400
3034	3000	3000
3035	3300	3300
3036	3300	3300
3037	2700	2700
3040	3000	3000
3041	2300	2300
3042	3100	3100
3043	3500	3500
3044	3300	3300
3045	3700	3700
3046	3400	3400
3047	2700	2700
3050	2200	2200
3051	3400	3400
3052	1600	1600
3053	1200	1200
3054	1300	1300
3055	0400	0400
3056	2600	2600
3057	3200	3200
3060	1500	1500
3061	0600	0600
3062	1400	1400

3063	0600	0600
3064	1200	1200
3065	1500	1500
3066	3200	3200
3067	3600	3600
3070	2700	2700
3071	0000	0000

APPENDIX III

Figures A.III.1 and A.III.2 show the wiring logic for the GPS 290T computer and the attached equipment.

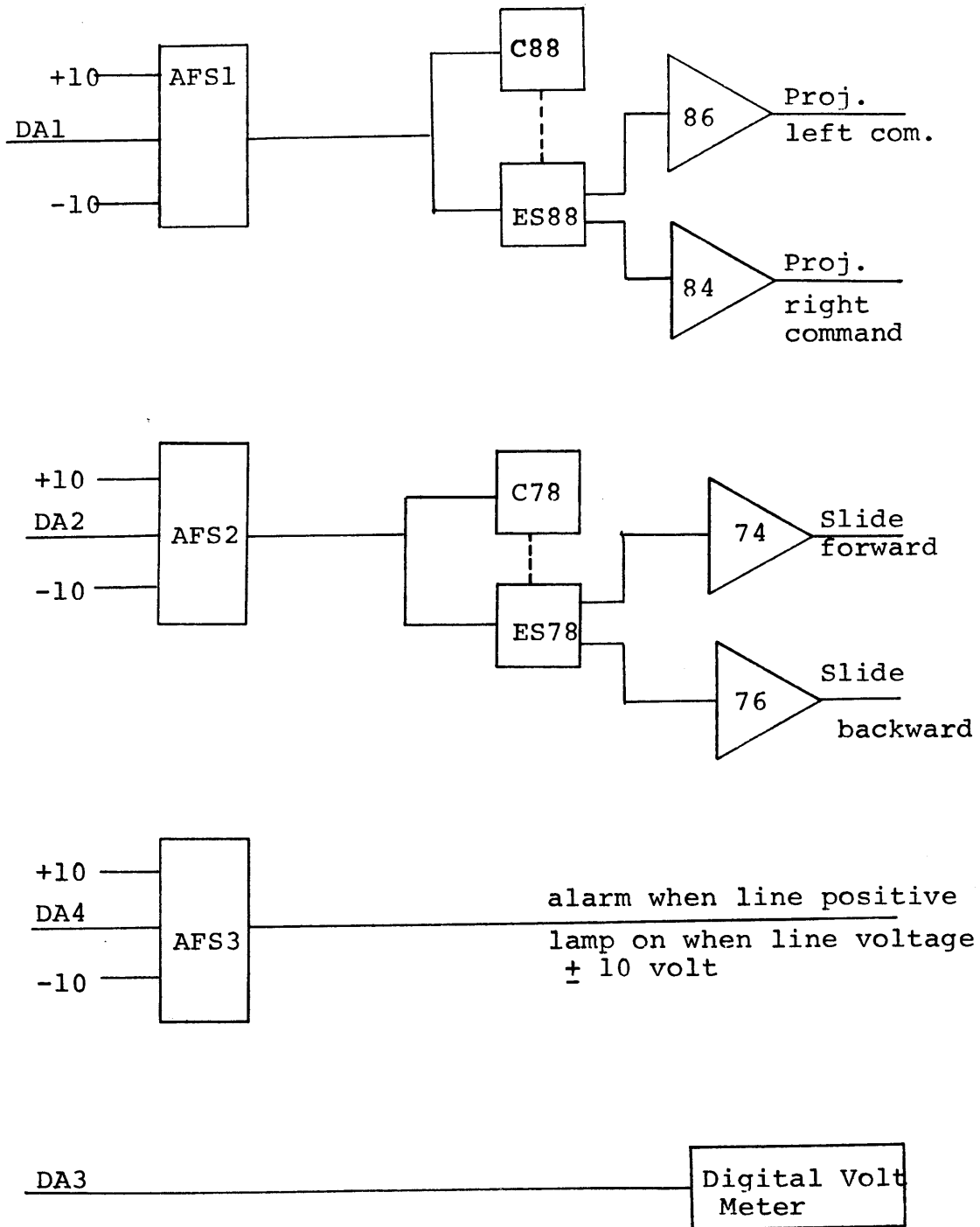

Digital to Experiment Links

Figure A.III.1

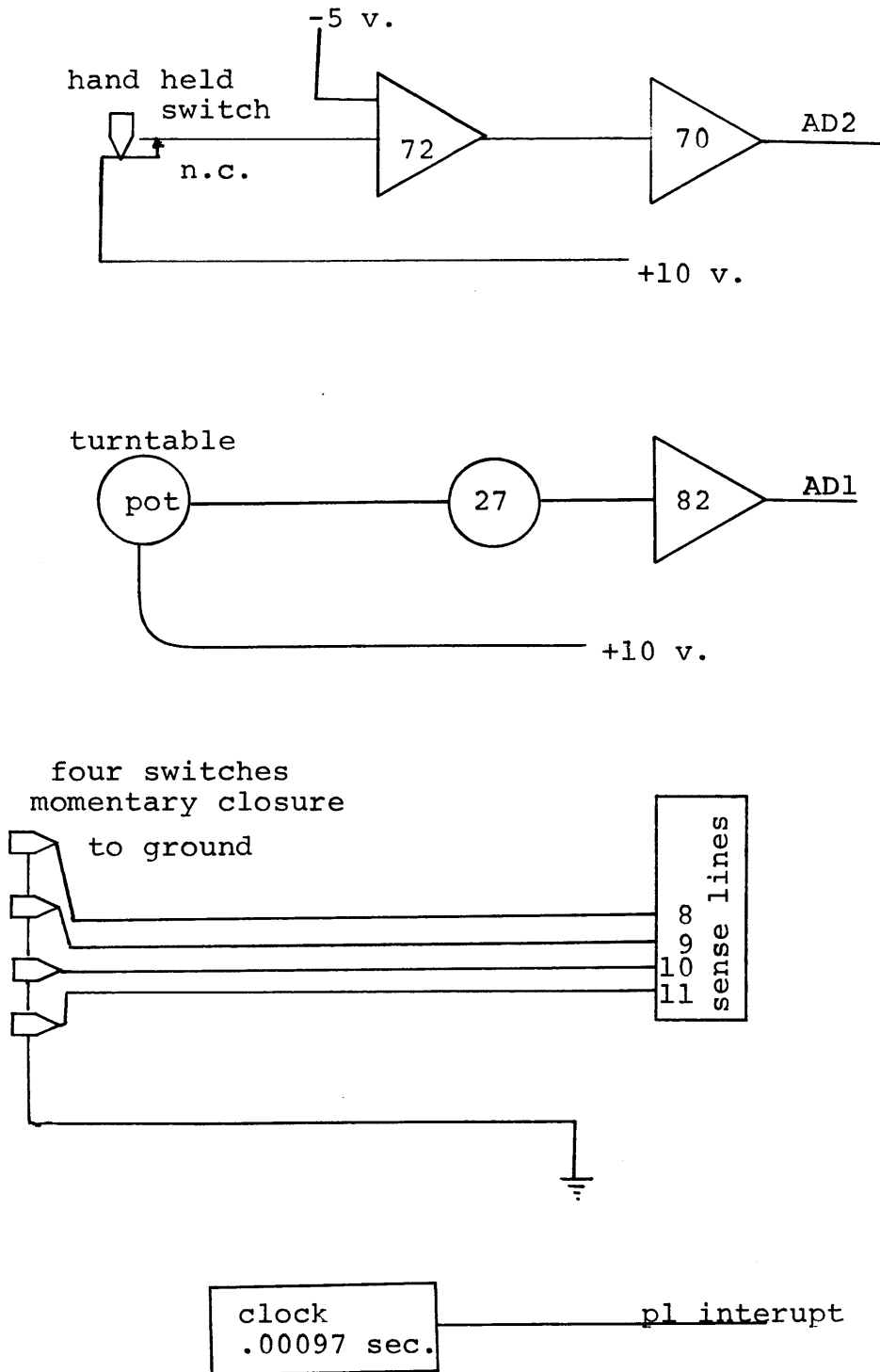

Figure A.III.2. Experiment to Digital Links

References

1. Adler, J.J., "Test and Evaluation of a Pilot Warning Indicator", NAVEPS Report 8080, AD No. 296325, January, 1963.
2. Applied Psychology Corp., "Analysis of the Usefulness of Coded Information in Visual Collision Avoidance", AD No. 259765, January, 1961.
3. Buck, Robert M., "Collision Prevention Equipment Display Factors", International Air Transport Association Thirteenth Technical Conference, Conference .13/WP-54, May, 1960.
4. Chapanis, Alphonse, Research Techniques in Human Engineering, Johns Hopkins Press, 1959.
5. Control Data Corp., "Human Factors Considerations in a PWI System, Part I", 6 April 1970.
6. Duntley, S.Q., Austin, R.W., Harris, J.L., and Taylor, J.H., "Experiments on Visual Acuity and the Visibility of Markings on the Ground in Long-Duration Earth-Orbital Space Flight", NASA CR-1134, November, 1968.
7. Johnson, Ivan S.C., "Human Tracking of Stroboscopic Beacon for Orbital Rendezvous", Master's Thesis, Department of Aeronautics and Astronautics, M.I.T., September, 1965.
8. Hasbrook, A. Howard, "A Comparison of Effects of Peripheral Vision Cues on Pilot Performance During Instrument Flight in Dissimilar Aircraft Simulators", AM 68-22, September, 1968.
9. Hasbrook, A. Howard, "Peripheral Vision Cues", FAA-AM 68-12, May, 1968.
10. Hasbrook, A. Howard, "Pilot Response to Peripheral Vision Cues During Instrument Flying Task", AM 68-11, May, 1968.
11. Ireland, Fred H., "Experimental Study of the Effects of Surround Brightness and Size on Visual Performance", AD 666-045, September, 1967.

12. Kuehn, Rudolph L., and Luxenberg, H.R., Display Systems Engineering, McGraw-Hill Book Co., 1968.
13. Linnert, Ted, "The Urgent Need for a Low Cost Short-Range Collision Prevention Device", National Transportation Safety Board Hearing into Mid-Air Collision Problem, 4-6 November 1969.
14. McDonnell, John D., "Pilot Rating Techniques for the Estimation and Evaluation of Handling Qualities", AFFDL-TR-68-76, December, 1968.
15. Paananean, Roy, Gunn, Keith, Sejfi, Protopapa, Ryan, Robert, and Story, Ann, "Compilation of Data from Related Technologies in the Development of an Optical Pilot Warning Indicator System", NASA TND-5174, May, 1969.
16. Rosenblith, Walter A., Sensory Communications, M.I.T. Press, 1961.
17. Shea, R.A., and Summers, L.G., "Visual Detection of Point Source Targets", NASA CR-563, September, 1966.
18. Siegel, P.V., and Mohler, S.R., "Medical Factors in U. S. General Aviation Accidents", AM 69-2, January, 1969.
19. Sperry Gyroscope Co., "A Study of Requirements for a Pilot Warning Instrument for Visual Airborne Collision Avoidance", AD 614-622, December, 1963.
20. Tibbeths, Paul, Perception, Quadrangle Book, Inc., 1969.
21. Vallerie, Leroy L., "Human Factors Program for the Cooperative Pilot Warning Indicator System", BSD No. 68-689, Contract NAS 12-203, 31 December 1968.
22. Volkman, John, Corbin, Horace H., Eddy, Nancy B., and Coonley, Carol, "The Range of Visual Search", ESD-TDR-64-535, AD No. 608810, November, 1964.