

A Machine for Tribological Experimentation on Indexing Continuous Media with Specific Application to Semiconductor Testing

by

Alexander D. Sprunt

S.B. Mechanical Engineering
Massachusetts Institute of Technology, 2000

SUBMITTED TO THE DEPARTMENT OF MECHANICAL ENGINEERING
IN PARTIAL FULFILLMENT OF THE DEGREE OF

MASTER OF SCIENCE

at the

MASSACHUSETTS INSTITUTE OF TECHNOLOGY

BARKER

June 2001

© 2001 Massachusetts Institute of Technology
All rights reserved

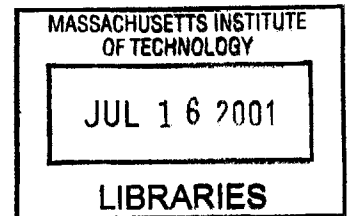

Signature of Author
Department of Mechanical Engineering
May 11, 2001

Certified by
Professor Alexander H. Slocum
Thesis Supervisor

Accepted by
Professor Ain A. Sonin
Chairman, Department Graduate Committee

A Machine for Tribological Experimentation on Indexing Continuous Media with Specific Application to Semiconductor Testing

by

Alexander D. Sprunt

Submitted to the Department of Mechanical Engineering
on May 23, 2001 in Partial Fulfillment of the
Requirements for the Degree of Masters of Science
at the Massachusetts Institute of Technology

ABSTRACT

Technology was developed to facilitate electrical contact tribology experiments on continuous media, dramatically reducing the difficulty of employing virgin material for each test. Specifically, a tester was designed to accurately reproduce semiconductor contactor operating environments while measuring contact resistance in-situ, thereby effecting the study of operating temperature, test current, cleaning method, and cleaning interval on contactor life. To manipulate the continuous media while preserving exact constraint, novel web handling machine elements were devised. Universal joints and beam type flexible couplings were employed for gimbaling and castering axes, both at standard caster radii and at roller center. A kinematic edge constraint was designed. The torque transmission properties of clamped connections were alloyed to the favorable kinematics of typical pinned type connections by compliantly mounting a spherical roller bearing as a pinch roller.

Thesis Supervisor:
Professor Alexander H. Slocum
Department of Mechanical Engineering

ACKNOWLEDGMENTS

Funding for this research was provided by Teradyne Corporation of Boston, Massachusetts. A large portion of the design work and all the assembly of the "Gummer," as the testing machine was affectionately known, took place at the Integra Test Division in Bedford, Massachusetts.

I would like to thank the future readers of this thesis. It is by no means certain there will be any, but I would like to thank these hypothetical (do I dare write it?) people just the same. On several occasions, I have been the first person to borrow a thesis from the library. Each time, I have thought with a smile about the shiver of excitement and pleasure that would pass through the author if they knew their thesis had just been checked out from the library. And on the off chance this thesis is widely read, I thank all those who follow the first reader as well. Do not feel compelled to read the whole. Chapter 1 and Chapter 4 are the most interesting.

Abstract	3
Acknowledgments	5
Nomenclature	17
Chapter 1. Realistic Spring Probe Testing Methods and Results	19
1.1 Abstract:	20
1.2 Introduction	20
1.3 Tester Description	21
1.4 Predictions and Preliminary Results	23
1.4.1 Source Current	23
1.4.2 Operating Temperature	24
1.4.3 Cleaning Interval	25
1.4.4 Cleaning Method	25
1.5 Conclusions	25
Chapter 2. Introduction	27
2.1 What is a Contactor?	27
2.2 What's the Problem?	29
2.3 A Solution	31
Chapter 3. Concept selection - Choosing a test medium	33
3.1 Why not use a handler, a tester, and real devices?	33
3.2 Gravity Feed	34
3.3 Big Disk	35
3.4 Foil Feed	38
3.5 Foil Location	38
3.6 Summary	41
Chapter 4. Applied Exact Constraint Web Handling	43
4.1 Abstract	43
4.2 Introduction	44
4.3 Kinematic Web Handling Background	45
4.3.1 Exactly Constraining Webs	45
4.3.2 Zero Constraint Rollers	47

4.3.3	Gimballed Rollers	51
4.4	Concepts	52
4.4.1	First Concept	53
4.4.2	Second Concept	54
4.4.3	The Edge Constraint	55
4.4.4	Web Plane Diagram	55
4.5	First Bench Level Prototype	57
4.5.1	Universal Joints	57
4.5.2	Making it Work	58
4.5.3	Pseudo-Stability	59
4.5.4	Edge Constraint	60
4.5.5	Limitations of the Concept	62
4.6	Second Bench Level Prototype: Internal Universal Joints	64
4.7	Third Bench Level Prototype: Internal Flexible Couplings	65
4.8	Final System	70
4.9	Conclusions	74
Chapter 5.	Plunging Module	75
5.1	Module Requirements	75
5.2	Spring Pin Arrangement	76
5.3	Bearings and Actuation	76
5.4	Preventing Foil Motion	79
Chapter 6.	Current Sourcing and in-situ resistance testing	83
6.1	Current Sourcing	83
6.2	In-Situ Resistance Testing	83
6.2.1	Worst Case	84
6.2.2	BLP Results	85
Chapter 7.	Controller Specification	87
7.1	System Components	87
7.2	System Schematic	88
7.3	Pneumatic Schematic	89
7.4	Operator Interface	89
7.4.1	Actions	89
7.4.2	Inputs	90

7.5 Sequences	90
7.5.1 Startup	90
7.5.2 Test Sequence	91
7.6 Data Logging and Operator Alert	91
Chapter 8. Test results	93
Chapter 9. Conclusions	99
9.1 Future Improvements	99
9.2 Additional Applications	101
9.3 Conclusions	101
References	103
Appendix A. Thermal Model Results	105
Appendix B. Web Handling details	107
9.4 Index Roller Wrap Angle	107
9.5 Minimum Roller Size	107
9.6 Index Roller Size	108
9.7 Slip Clutch	108
9.8 Idler Rotation Disk	109
Appendix C. Part and assembly drawings	111

Figure 1.1	Isometric view of test machine	21
Figure 1.2	Resistance test schematic. Note that conduction path includes the frame and the Graphalloy™ bearings.	23
Figure 2.1	A picture of a QA Technologies spring probe and a cross section view of a typical spring probe. (from QA Technologies Catalog)	28
Figure 3.1	A Handler-Tester System (Delta Design Company)	33
Figure 3.2	A gravity feed handler (Delta Design Company)	34
Figure 3.3	CIRRIS Tester	35
Figure 3.4	Sketch of Big Disk testing system, side and top views	36
Figure 3.5	Various Probe tip types (reproduced from QA Technologies' catalog)	37
Figure 4.1	Two methods of exactly constraining a web.	46
Figure 4.2	Decay of cross track error as the instant center moves closer to infinity	47
Figure 4.3	Adding an additional roller can cause over constraint if the new roller is not carefully chosen. Overconstraint manifests itself as multiple instant centers of rotation, which can destroy a web. The appropriate web plane diagram symbols have been overlaid on this figure.	48
Figure 4.4	A fanciful axially compliant roller that is unworkable because it has only one roller surface, and can therefore never leave contact with the web, preventing it from resetting.	50
Figure 4.5	“B” is a gimballed roller (figure reproduced from Blanding)	51
Figure 4.6	By taking advantage of the three dimensional twist compliance of section A-B, the gimballed roller (B) creates a joint in the web plane. The section A-B is exactly constrained by the edge constraint at A and the angular constraint at B. The section B-C is exactly constrained by the implied axial constraint at B and the angular constraint at C. The overlaid web plane symbology is explained below.	52
Figure 4.7	“Movie Projector” style arrangement	53
Figure 4.8	Second, and more space efficient arrangement	54
Figure 4.9	Web Plane diagram for both arrangements, mis-alignment is deliberately exaggerated to emphasize any overconstraint.	56
Figure 4.10	A universal joint mounted to provide gimbaling and castering. Note the length of the caster radius, i.e. the distance between the universal joint and the axis of rotation of the spool.	57
Figure 4.11	The plan for implementing arrangement two in hardware. Note the gravity defying positions of the supply and take-up spools. The frame is not shown.	58

Figure 4.12	Slightly modified “movie projector” arrangement. Note the counterweights and that gravity and foil tension are loading the universal joints in tension. 59	
Figure 4.13	The foil finding its own edge constraint	60
Figure 4.14	The kinematic edge constraint. A cam follower on a spring arm nests the web against the fixed cam follower to create an edge constraint. The third cam follower turned out to be superfluous.	62
Figure 4.15	Spool assembly, note the size of the counterweight.	63
Figure 4.16	A cross track position of zero indicates alignment is complete. Reducing the caster radius to zero resulted in instantaneous alignment of the roller. Determining if this was a problem was one goal of the second bench level prototype.	65
Figure 4.17	Spool core with internal universal joint providing gimbaling and castering axes.	66
Figure 4.18	Spool mount based on a flexible coupling. Functionally equivalent to the hardware in Figure 4.10.	67
Figure 4.19	Section of a spool core based on flexible coupling	69
Figure 4.20	The flexible coupling bench level prototype without foil loaded.	69
Figure 4.21	Web Plane Diagram of BLPs two and three that does not include castering at the flexible couplings. Note the “tears” in the web where it is overconstrained.	70
Figure 4.22	The spring mounted spherical roller bearing and the index roller	72
Figure 4.23	A picture of the pinch roller assembly	73
Figure 4.24	The final machine. The ribbon cables are used to test the contactors.	73
Figure 5.1	Spring Pin arrangement to optimize foil utilization while maintaining index system simplicity	76
Figure 5.2	Flexure designed for linear motion for 1/2 inch stroke over a broad temperature range	77
Figure 5.3	Contactors sub-assembly with flexures and piston attached	77
Figure 5.4	The plunge sub-system attached to the machine frame	78
Figure 5.5	A picture of the contactor assembly showing the stops and the spring pins 79	
Figure 5.6	Top view of plunging module (with the actuating piston removed) showing the two dimensional kinematic coupling used to align the contactor plate with the plunging module	80
Figure 5.7	Front View of plunge sub-system - note the feet	81

Figure 6.1	Resistance test schematic. Note that conduction path includes the frame and bushings.	84
Figure 6.2	Picture of Graphalloy resistance test bench level prototype. Note the heavy gage wire for current sourcing and the smaller gage wire for four wire resistance measurement.	85
Figure 6.3	Cross-section of bench level prototype for testing Graphalloy resistance. The BLP was connected to a power supply to simulate the effects of the current source array driving current through the contactor. The digital multimeter tested the resistance of the assembly using the four-wire method.	86
Figure 7.1	System Schematic, the contractor was responsible for the components inside the dashed box.	88
Figure 7.2	System Pneumatic Schematic. Valve assembly, regulator, etc. supplied by contractor. Actuators already installed on machine	89
Figure 8.1	Wide field view of the witness marks left by the array of spring pins on the 90/10 Sn/Pb clad Alloy 42 foil (37.5 X magnification)	93
Figure 8.2	Tight field view of the witness marks (203 X magnification)	94
Figure 8.3	A plot of contact resistance vs. number of hits for several different current settings	95
Figure 8.4	The mean of each pin's resistance measurements is plotted against the amount of current sourced through the pin. The squares represent the average of those averages for each current group.	96
Figure 8.5	Plots of the resistance data for all ten pins in the 100 mA group. For unknown reasons, the contact resistance of pin 19 is consistently higher than that of the other pins.	97
Figure 9.1	A cross section of the slip clutch	109
Figure 9.2	The idler rotation disk mounted to the shaft of the idler roller. The fiber optic sensor is mounted in the small hole in the bracket to the right of the disk.	110

TABLE 1.1	Paper Authors	19
TABLE 1.2	Properties of some contact materials	24
TABLE 2.1	Properties of some contact materials	29
TABLE 3.1	Air Properties	39
TABLE 4.1	Paper Authors	43
TABLE 4.2	The three types of zero constraint rollers	49
TABLE 4.3	61
TABLE 4.4	Modes of Helical Coupling Misalignment.	68
TABLE 7.1	Inputs	90

NOMENCLATURE

C_{res}	contact resistance [Ω]
β	beta, reciprocal temperature [1/K]
T	temperature [K]
$T_{ambient}$	ambient temperature (outside environmental chamber) [K]
$T_{chamber}$	environmental chamber temperature [K]
k	thermal conductivity [W/mK]
ν	kinematic viscosity [m ² /s]
ΔT	temperature change [K]
Gr_L	Grasshof Number with respect to length [-]
Pr	Prandtl Number [-]
Ra_L	Rayleigh Number with respect to length [-]
Nu_L	Nusselt Number with respect to length [-]
d	distance between an edge constraint and a fixed roller [m]
y	cross track displacement of a web [m]
y_0	cross track displacement boundary condition [m]
x	in-track displacement of web [m]
r_c	caster radius [m]

Chapter 1

REALISTIC SPRING PROBE TESTING METHODS AND RESULTS

This chapter is a summary of the entire thesis and was submitted to the International Test Conference as a 2001 conference paper.

TABLE 1.1 Paper Authors

Walter DiVito

Teradyne, Inc.
26 Crosby Drive
Bedford, MA 01730

vox: (781) 999-8464
fax: (781) 999-8289
Walter_Divito@teradyne.com

Alexander H. Slocum

Massachusetts Institute of Technology
Room 3-455
77 Massachusetts Avenue
Cambridge, MA 02139

vox: (617) 253-0012
fax: (617) 258-6427
slocum@mit.edu

Scott Ziegenhagen

Teradyne, Inc.
44 Simon Street
Nashua, New Hampshire 03060

vox: (603) 879-5449
fax: (603) 879-4449
Scott_Ziegenhagen@teradyne.com

David Gessel

Teradyne, Inc.
26 Crosby Drive
Bedford, MA 01730

vox: (781) 999-8366
fax: (781) 999-8289
gessel@dis.org

Alexander D. Sprunt

Massachusetts Institute of Technology
Room 3-470
77 Massachusetts Avenue
Cambridge, MA 02139

vox: (617) 253-1953
fax: (617) 258-6427
asprunt@mit.edu

Presenter: Alexander D. Sprunt

Topics: Tools for Understanding Contactor Systems

1.1 Abstract:

A tester was developed to accurately emulate spring probe operating environments. The effects of operating temperature, test current, cleaning method, and cleaning interval on spring probe life were systematically studied.

1.2 Introduction

Despite the widespread dependence on such systems for back-end testing, the lifetime and the variables that materially influence the lifetime of contactor systems have not been systematically studied. Spring probe manufacturers test mechanical life, but such data is of little use to the system designer. Mechanical lifetimes in excess of one million cycles are commonly seen during such tests, but similar performance is unheard of in the field. Fore-shortening of probe life due to plunge errors and cleaning mishaps can be prevented, or at least minimized, by a robust interface design, but the specifics of probe contamination and cleaning necessary for coherent systems design remain unknown. To remedy this omission, a probe tester has been developed. The tester reproduces actual contactor working conditions with high fidelity while measuring contactor resistance (C_{TCS}), the industry standard metric for probe health.

The tester has been used to evaluate spring probe life against the following variables over the accompanying ranges:

- Source Current (0-200mA per probe)
- Operating Temperature (20°C-150°C)
- Cleaning Interval (cleaning every 10k hits - no cleaning)
- Cleaning Method (various brush types, Electro-Hydro-Dynamic (EHD))

Future experiment variables and their current values:

- Spring Probe Base Material (BeCu)
- Spring Probe Plating Material (plated gold over nickel)
- Device Under Test Base Material (Alloy 42)
- Device Under Test Plating (90/10 SnPb)

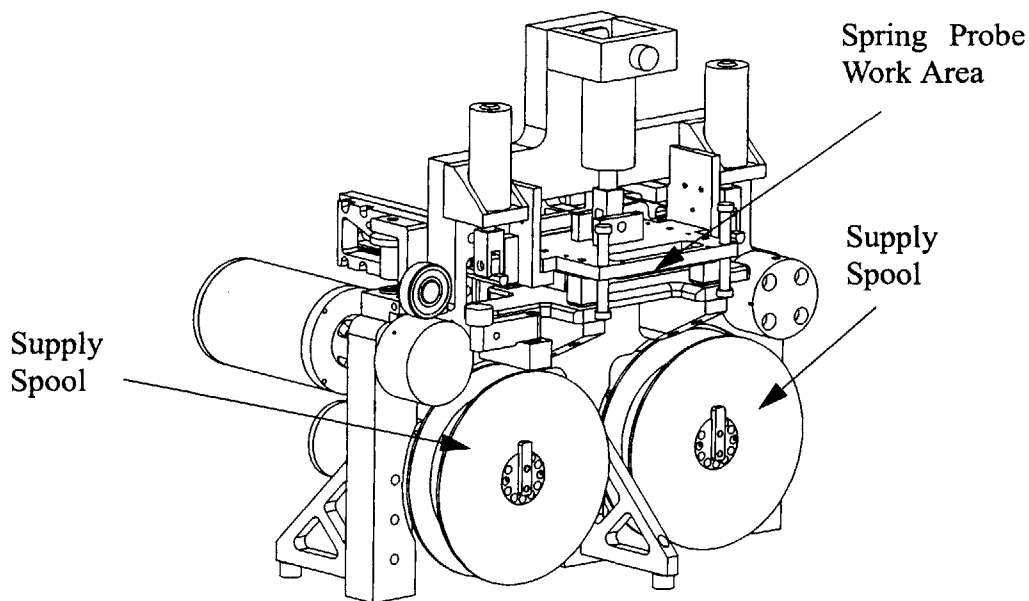

Figure 1.1 Isometric view of test machine

1.3 Tester Description

The tester was designed around the experiments it was intended to perform. The quantity of testing requires the tester to operate autonomously for extended periods of time. A single run of 20k hits, a typical cleaning interval, at one and a half seconds per hit will take over eight hours. The “lead frames” being tested also must be presented to the contactor head at operating temperature. To do otherwise invalidates the test. The solution is to store all the “lead frames” to be consumed during a test period inside the environmental chamber maintaining the tester at operating temperature.

Both cost and the necessity of fitting inside the environmental chamber make actual lead frames a poor choice for the test medium. Instead, a continuous foil with the same thickness and composition as a standard lead frame was adopted. The foil need only be wound off the supply reel, presented to the spring probe array, and wound onto the take-up reel (Figure 1.1).

The spring probes are presented with virgin material for each contact in order to mimic actual operating contamination in a handler. In a compromise between packing constraints and statistics, the tester was designed to hold fifty spring probes, that have been mounted and aligned to optimize foil use while simplifying the indexing motion.

Realistically reproducing spring probe operating conditions serves no purpose if the condition of the probes cannot be monitored. To that end, the tester does in-situ four-wire resistance measurement of each of the fifty spring probes. The two connections to each probe's receptacle are accomplished quite readily by mounting the receptacles in a circuit board, but the other two connections are somewhat more circuitous. The return path for the current used in the four-wire test and the second voltage probe connection are both made via the tester frame (Figure 1.2). Naturally, the resistance of this path was a concern.

The worst case resistance scenario for making these connections through the tester frame is if the current all travels through only one of the bearing sets supporting the foil advance sub-system. Bench level testing revealed (and later use of the tester confirmed) that this line contact inside the Graphalloy™ bearing has a negligibly small resistance of only a few milliohms.

The tester was designed with the assumption that C_{res} could be greatly influenced by the amount of current sourced through each probe. Because of this predicted coupling, the current through each of the fifty spring probes is independently sourced. If the voltage across the whole probe array had been regulated instead, more current would have flowed through the lower resistance probes. Since current affects C_{res} , sourcing current in this

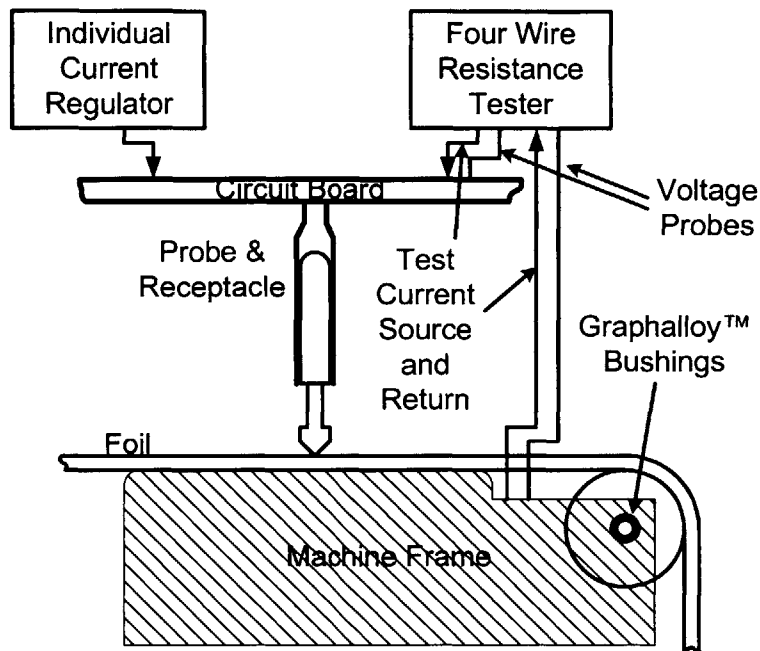

Figure 1.2 Resistance test schematic. Note that conduction path includes the frame and the Graphalloy™ bearings.

manner would have created a feedback loop, that would work to make the resistance of each probe equal to that of every other probe

1.4 Predictions and Preliminary Results

1.4.1 Source Current

It was anticipated higher source currents would decrease spring probe life. The contact regions between spring probes and devices under test are very small. The small size of these regions is not an artifact. Designers favor smaller contact regions because they are more effective at piercing any oxidation or contaminant layers that form atop the devices under test. Imagine driving a sharp stick (the probe) through a thin layer of ice (the oxidation layer) to get to the mud underneath (the base material). Oxidation films form extremely quickly. Even gold forms a 0.3 Ångstrom film within 2 minutes of exposure to air. But though quite hard (Table 1.2), oxides are also brittle and quite resistive.

TABLE 1.2 Properties of some contact materials

Element	Resistivity (ohm-cm)		Tensile Strength (MPa)	
	Pure	Oxidized	Pure	Oxidized
Aluminum	$2.65 \cdot 10^{-6}$ ^a	$>10 \cdot 10^{14}$ ^a	45 ^b	2944 ^a
Beryllium	$4 \cdot 10^{-6}$ ^c	$>10^{17}$ ^a	300 ^b	1462 ^a

a. [Shackelford, 2000]

b. [Buch, 1999]

c. [Bauccio, 1993]

Test currents are almost always small, but the ohmic heating these currents induce is intense because the regions themselves are so petit. This heating creates microscopic solder joints between solder balls or solder coated leads and probe tips. Each time a spring probe lifts off a device under test, this solder joint breaks, and some of the solder cladding from the lead frame is carried away with the probe tip. As the principal source of contamination in the testing process, this is the contaminant the various cleaning processes strive to remove. The contaminant is harmful because it degrades the probe's ability to make contact with the device under test. A stick with a big glob of mud at the tip does not punch through ice nearly so well as a clean stick.

It is anticipated that because higher source currents create more ohmic heating at the interface, contamination will be accelerated by higher currents. Testing has begun, and the tester is accurately reproducing operating conditions, but data is not available at this time

1.4.2 Operating Temperature

It was anticipated that higher temperatures would decrease spring probe life. Both anecdotal evidence from customers and our understanding of the process gave rise to this belief. Higher temperatures make the solder cladding on the lead frames softer, and softer cladding is more likely to rip away from the base material when the source current solders the probe tip to the lead frame.

1.4.3 Cleaning Interval

This experiment sequence features fewer unknowns than the others. The effectiveness of cleaning at extending spring probe life is an extremely widely held belief, especially among spring probe manufacturers. Company A recommends cleaning their contactors every shift. Not doing so voids their warranty. Company B reports that effective contact life varies by two orders of magnitude depending on installation and cleaning methods. Company C reports that contamination and a lack of reliable cleaning method is the typical cause of death for their spring probe board test products. A more quantitative understanding of the process is desired. How much cleaning is necessary to substantially improve contactor life? How should cleaning cycle interval be adjusted to accommodate particular environmental conditions? How can cleaning methods and frequencies be optimized from a systems standpoint.

1.4.4 Cleaning Method

The most widespread back-end cleaning method is brushing. We wanted to know if any type of brush is more equal than the others, and also whether there exists some other acceptable cleaning method more suitable to automation. We therefore experimented with various different kinds of brushes (fiberglass, stiff horse hair, brass, stainless steel, and low carbon steel) and different cleaning methods such as electro-hydro-dynamic (EHD).

1.5 Conclusions

The tester holds the promise of for the first time enabling systematic testing of spring probes and other contacting technologies performance under actual operating conditions.

Chapter 2

INTRODUCTION

2.1 What is a Contactor?

Semiconductors are tested throughout the manufacturing process. A tester transmits test signals to the Device Under Test (DUT), monitors the output, and determines if the device is good. DUTs are electronic devices, and the signals they receive and transmit are electrical in nature. A contactor provides the electrical connections between the tester and the DUTs. A contactor may connect a tester to one device at a time or it may have multiple regions of contact elements (each element makes one connection), and facilitate the testing of many devices in parallel. As machines on an automated manufacturing line, a tester and its contactor test thousands of devices each shift, making and breaking electrical contact each time.

There are many different types of contactors. While the principles outlined here are applicable to all contactors, this thesis will focus on contactors employing spring probes as their contact elements. With some application specific modifications, the test machine in this thesis could generate data for most any kind of contactor, but from the outset, spring probe data was seen as being of the most immediate use. For simplicity, all explanations will use the nomenclature of spring pins rather than that of generic contactors. Extension to other particular types of contactors will be left as an exercise for the reader.

Spring probes are popular for back-end testing. The back-end is defined as all processes that occur after fabrication of the transistors is complete, e.g. metallization, dicing, and packaging. Spring probes' telescoping design accommodates the variations in surface height common to the back-end. A typical spring probe has three parts: a probe, a tube, and a spring (Figure 2.1). The probe makes contact with the DUT. The tube guides the telescoping motion of the probe, and the spring applies a restoring force opposing that telescoping action.

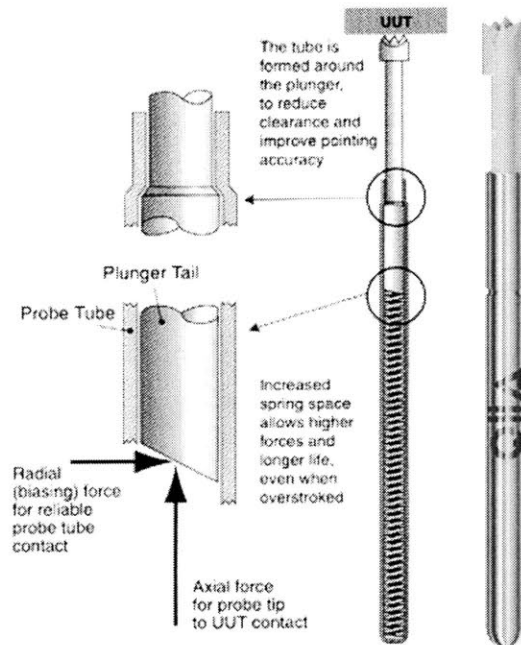

Figure 2.1 A picture of a QA Technologies spring probe and a cross section view of a typical spring probe. (from QA Technologies Catalog)

Handlers present DUTs to testers. Customers, especially the military, often require devices be tested at extreme temperatures. A typical range is -50 to 150°C . If a device is to be tested at temperature, the handler may also be responsible for slewing the device from ambient. Because good electrical connections are also good thermal connections, heat will flow between the DUT and the contactor in the presence of a temperature gradient. As the

thermal mass of a DUT is often much smaller than that of the contactor touching it, fast changes in device temperature are possible. Great care is therefore taken to maintain the contactor at the temperature of the DUTs, because to do otherwise would defeat the purpose of testing at temperature.

2.2 What's the Problem?

Even “noble” metals oxidize. Gold forms a 0.03 nm thick oxidation layer after 2 minutes of exposure to air. Aluminum oxide grows at approximately 2 nm per minute. This oxidation layer is insulative (Properties of some contact materials Table 2.1) and must be pierced before the currents associated with the signal voltages can be passed. This is what a contactors does.

Oxidation layers are ceramics and tend to be quite hard but brittle. (Table 2.1); sapphire is impure aluminum oxide. Fortunately, these oxide layers sit atop (unoxidized) base material that is much softer and conductive (Table 2.1). The tips of spring probes are often

TABLE 2.1 Properties of some contact materials

Element	Resistivity (ohm-cm)		Tensile Strength (MPa)	
	Pure	Oxidized	Pure	Oxidized
Aluminum	$2.65 \cdot 10^{-6}$ ^a	$>10 \cdot 10^{14}$ ^a	45 ^b	2944 ^a
Beryllium	$4 \cdot 10^{-6}$ ^c	$>10^{17}$ ^a	300 ^b	1462 ^a

a. [Shackelford, 2000]

b. [Buch, 1999]

c. [Baucchio, 1993]

macroscopically sharp, but when piercing oxidation layers, the microscopic peaks and valleys present on even a polished probe are what matter. The probes are made of hard metals such as beryllium copper (BeCu) or steel, and when the probe is plunged, the microscopic peaks on its surface pierce the oxidation layer just as a stick may be used to punch through

the ice atop a mud puddle. The bulk resistance of the underlying base material is low (Table 2.1), so good, i.e. low resistance, contact is achieved once the probe reaches this material.

Because of the nature the oxidation layer penetration, many small peaks punching through a hard but brittle medium, the area where one conductor makes intimate contact with the other tends to be quite small. The currents passed also tend to be small, but because the areas are also petit, the current flux is quite high. This high current flux results in enough ohmic heating to spot weld the probe tips to the DUT. When the contactor is withdrawn, these spot welds do not break cleanly. Some of the soft underlying base material is ripped off the DUT and adheres to the probe tip. The phenomenon is aggravated by increased temperature, for the base material softens, making it more susceptible to traumatic removal.

As base material accumulates on the probe tip, the probe becomes less effective at making contact with the DUT. Imagine trying to punch through a sheet of ice with a stick whose pointy end is covered with mud. The industry standard metric for contact effectiveness and health is contact resistance, C_{res} , a measurement of the resistance from the probe through to the DUT. As mentioned before, the bulk resistances of the materials on either side of the contact region are low, so the bulk of the contact resistance comes from the contact region. Contact resistance must be low for effective testing because when combined with the system's inherent capacitance it forms a low pass filter. This low pass filter interferes with testing, so after a spring probe has been made sufficiently dirty, it must either be replaced or cleaned.

In the back-end, this cleaning is done manually with a fiberglass brushes. During operation, the contactor is sandwiched between the tester and the handler. The system must therefore often be partially disassembled for contactor cleaning or replacement. During this maintenance, expensive hardware sits idle.

Worse, a whole contactor does not fail at once. Individual probes may fail long before others, and since multiple DUTs are often tested by a single contactor (parallel testing), the manufacturer is faced with a difficult choice. If operation is continued, devices at the bad sites will have to be discarded or re-tested. If operation is suspended, valuable machine time will be wasted and throughput will suffer. It is also impossible for the manufacturer to know whether replacing the single bad element will have any lasting benefit. After cleaning or replacement, testing may resume only to have another site may fail. There is no systematic predictive data, operator experience governs these decisions.

To make matters still worse, there is no bright line for contact failure. Failure is often intermittent and must be detected by tracking the yield for each region of the contactor. If the manufacturing process is under control, the operator knows some percentage of devices are expected to fail. If a contactor region detects more than its share of failures, it may come under suspicion, but until it is tested off-line, little can be known for sure.

Manufacturers of testing equipment face these same questions, but without the benefit of employing experienced line operators. The answers impinge on many important design decisions. What is the optimum level of contactor parallelism? What is the optimal contactor for a particular application? Of what material should the contactor be made? Should contactor maintenance be scheduled rather than being conducted on an ad-hoc basis, and if so, what should the interval be? How much effort should be dedicated to making the tester-contactor-handler system rapidly serviceable? How can contactor problems be better managed at a systems level

2.3 A Solution

The testing machine described in this thesis was designed to provide the data to answer these and other questions. In light of the theories about the mechanisms of contactor contamination, the machine was required to test at temperature, to provide a virgin “DUT” for each hit (more on the quotations marks later), and to source current to replicate test cur-

rent. The following machine parameters are reconfigurable (typical values and ranges are in parenthesis):

- Source Current (0-200mA per probe)
- Source Current Duration (0-arbitrary)
- Spring Probe Plunge Distance (full range)
- Spring Probe Geometry (arbitrary with 90 degree cone baseline)
- Operating Temperature (20°C-150°C)
- Cleaning Interval (cleaning every 10k hits - no cleaning)
- Cleaning Method (various brush types, Electro-Hydro-Dynamic (EHD))
- Spring Probe Base Material (BeCu)
- Spring Probe Plating Material (plated gold over nickel)
- Device Under Test Base Material (Alloy 42)
- Device Under Test Plating (90/10 SnPb)

While reproducing contactor operating conditions along the lines of the parameters above, the test machine measures and records the contact resistance of each spring pin at an operator specified interval. Tests such as auger spectroscopy of the probe tips, examination of the “DUTs,” and post-mortems on the spring probes are performed offline.

Naturally, this is not the first machine designed to test contactors. Contactor vendors do test their products. Unfortunately, their principal concern is mechanical life. And while they do test at temperature, a hard contact target is used instead of anything more akin to a DUT. Manufacturer’s testing is also done without sourcing current. The mechanical lifetimes measured are on the sunny side of 1 million hits, while semiconductor manufacturers would be astounded by lifetimes a tenth as long. It is hoped that improved testing fidelity will mend the relation between testing and practice, resulting in enhanced practice.

Chapter 3

CONCEPT SELECTION - CHOOSING A TEST MEDIUM

3.1 Why not use a handler, a tester, and real devices?

Using existing equipment conduct the testing is an obvious option. All the engineering has already been done. It might seem that after some software was written and some off-the-shelf equipment purchased, testing could begin immediately. This is likely the case, but there are some serious caveats. First, while much is made of incessant drop in the prices of semiconductor devices, such devices are still not free. With potential hit counts measured in the millions, the cost of using real devices (even at the improbable cost of \$0.01 each) is prohibitive. Finally, testers and handlers (Figure 3.1) are major pieces of capital equipment, and while obtaining the data is important, it could not justify tying up \$0.50 million of equipment indefinitely.

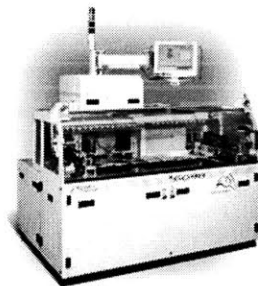

Figure 3.1 A Handler-Tester System (Delta Design Company)

3.2 Gravity Feed

A close substitute for using a full fledged handler/tester system would be to employ a gravity feed machine, a limited kind of tester like a cable tester from CIRRIS, and test devices. Each cycle, the gravity feed machine would present a test device to the contactor. The contactor would be plunged into the test device. Custom electronics would source current to approximate testing conditions. At some user specified interval, the contactor would be plunged against a “gold brick” or some other low resistance electronically inert medium while the CIRRIS tester measured contact resistance.

Gravity feed machines hold devices in a magazine, and use gravity to place devices into a work area. In addition to being readily available, they are already designed to run at temperature, so housing the whole setup in an environmental chamber would satisfy the requirement for at temperature testing. Prima facie, finding such a machine with sufficient capacity small enough to fit inside the available environmental chamber should not be extremely difficult.

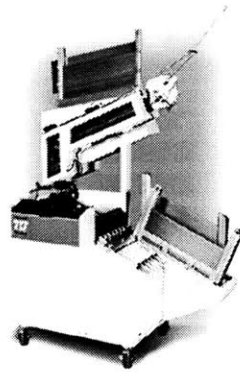

Figure 3.2 A gravity feed handler (Delta Design Company)

Unlike full fledged testers, cable testers measure only resistance. They cannot perform the more advanced input-output highly time dependant tests full-fledged testers do. Not coincidentally, they are much less expensive. Also, a Signature Touch One cable tester from

CIRRIS Systems Corporation was already available. Because of the CIRRIS' limited capabilities, custom electronics would have to be designed and built to source current through the contactor, but such circuits are well understood, so this was not considered a challenge.

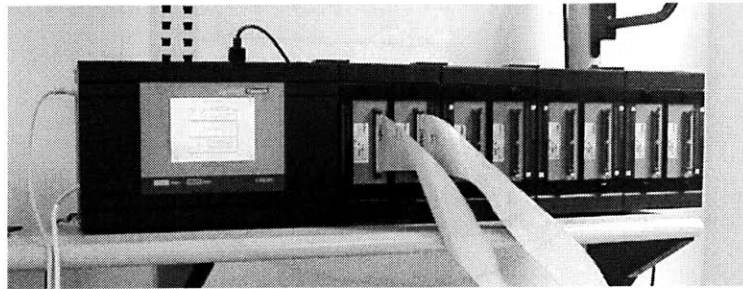

Figure 3.3 CIRRIS Tester

When testing against DUT like material has been done in the past, test devices have been used. Test devices are equivalent to real devices from a contactor's perspective. They have the same form factor and the leads are the same as those on a real device, but they are electronically inert. Alas, they are also relatively expensive (\$0.10 to \$2.00). And fresh devices must be provided every hit, for in a previous experiment using test devices, when no attempt was made to provide virgin devices for each hit, the contactor being tested eventually wore through the test device.

3.3 Big Disk

Having found the use of real devices and test devices, despite the advantages of being able to use off the shelf equipment, to be unacceptable, alternatives were sought. One such alternative to using devices is combining a big disk (or rectangle) coated with typical lead-frame cladding and a servo axis to position the contactor anywhere over the disk.

Each cycle, the contactor would be advanced to a new location above a virgin area on the test disk. The contactor would then be plunged into the disk. As before, current would be

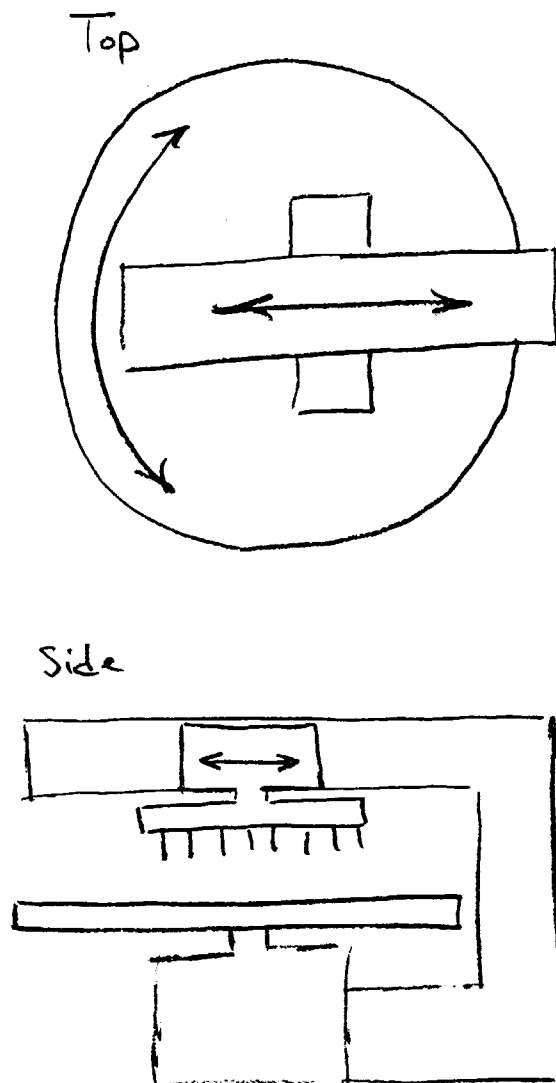

Figure 3.4 Sketch of Big Disk testing system, side and top views

sourced through the contactor by custom electronics. For resistance measurement, a cable tester could be wired into both the disk and the contactor. Measurement could be programmed to occur at the discretion of the operator.

The disk is made of the same material as typical device contacts, and has been clad similarly, so the physics of the contact mechanics and contamination process should be essentially the same. Most of the packaging congruity provided by using real or test devices is

not needed. This type of setup cannot fully reproduce the probe-DUT interaction for devices having non-planar contact regions. A typical example of this is the Ball Grid Array (BGA) type device. A BGA consists of a grid of small spheres. Each sphere is contacted by its own spring probe. Spring probes for BGA applications do not have a single point, but rather a series of them surrounding a common center (see Figure 3.5). This combination self centers and creates three point contacts between the probe and the sphere. While this is not identical to single point contact against a plane, it was felt that results of a relative nature would be sufficient.

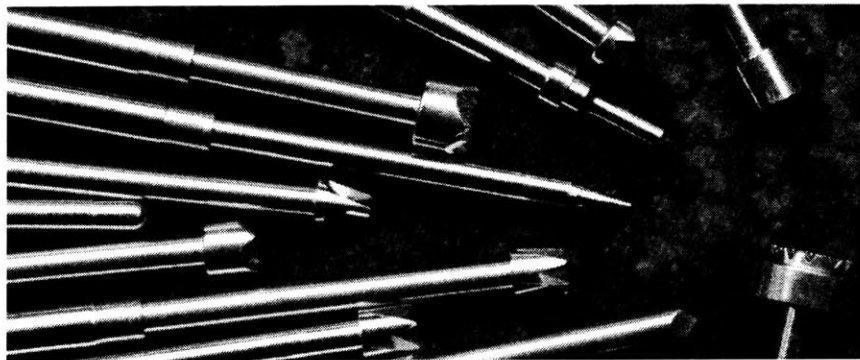

Figure 3.5 Various Probe tip types (reproduced from QA Technologies' catalog)

The problem with this solution is entirely practical. The available environmental chamber has an internal volume of only 22 by 20 by 19 inches. Being optimistic, a disk of 396 square inches ($22 \times 20 \times 0.9$ - for overhead) could be fit inside the chamber. Experts advised that maintaining virgin material conditions would require each probe to touch down in its own 0.025" by 0.025" square of pristine material. Fifty spring probes could be tested at one time by the CIRRISS tester and was large enough to make for statistically meaningful results. But the industry standard cleaning interval is every 20k hits, and it was desired that the testing machine be able to run unattended for at least that long, so the minimum area was 625 square inches ($20,000 \text{ hits} \times 50 \text{ pins} \times 0.025 \text{ in}^2 \text{ per pin hit}$). A disk big enough to meet the requirements would not fit in the available environmental chamber.

3.4 Foil Feed

Using continuous foil instead of a disk solves the area problem. The disk system made all of its area available at all times, which was not necessary. Foil can be wound off a supply spool, presented to the contactor, and wound back onto a take-up spool. Otherwise, the cycle is identical to disk cycle.

3.5 Foil Location

Indeed, switching from a disk to a foil based system could have obviated the area problem entirely. Unlike the disk, the foil was small enough to move in and out of the environmental chamber. A hole already existed in the chamber's side, and it was possible to enlarge hole without damaging the chamber's performance. Three different possibilities existed: mount both the supply and take-up reels outside the chamber, mount the supply reel inside the chamber and the take-up reel outside, and mount both reels inside the chamber.

Mount Both Spools Outside the Chamber

The key to mounting both spools outside the chamber was heat transfer. Could the incoming foil be brought to the environmental chamber's temperature before it reached the contactor working area? To answer this question, a simple thermal model was constructed.

Linear and quadratic relations are used to interpolate between the data points in Table 3.1. The temperature of the environmental chamber may be set anywhere from -50C to 150C, and as it is not obvious a priori which is the limiting case, the calculation is done a 25 C increments between the two. Beta is calculated:

$$\beta = \frac{1}{T}. \quad (3.1)$$

Because it varies as the foil is brought to temperature, ΔT is approximated as the mean of the difference between the outside ambient temperature (293K), and the chamber temperature:

TABLE 3.1 Air Properties

Temperature (K)	Kinematic Viscosity, ν (m ² /s)	Conductivity, k (W/mK)	Prandtl Number, Pr
200	$7.590 \cdot 10^{-6}$	$1.81 \cdot 10^{-2}$	0.737
250	$1.144 \cdot 10^{-5}$	$2.23 \cdot 10^{-2}$	0.720
300	$1.589 \cdot 10^{-5}$	$2.63 \cdot 10^{-2}$	0.707
350	$2.092 \cdot 10^{-5}$	$3.00 \cdot 10^{-2}$	0.700
400	$2.641 \cdot 10^{-5}$	$3.38 \cdot 10^{-2}$	0.690
450	$3.239 \cdot 10^{-5}$	$3.73 \cdot 10^{-2}$	0.686

$$\Delta T = \frac{T_{ambient} - T_{chamber}}{2}. \quad (3.2)$$

The Grasshof and Rayleigh Numbers are then calculated:

$$Gr_L = \frac{\beta g L^3 (\Delta T)}{9}, \quad (3.3)$$

$$Ra_L = Gr_L \times Pr. \quad (3.4)$$

With those calculations complete, the specific Nusselt Number relations can be used for each of the different modes the foil may be in:

Vertical Wall ($Ra_L < 10^9$) [Mills, Table 4.10]:

$$\bar{Nu} = 0.68 + 0.670 \left[Ra_L \times \left(1 + \left(\frac{0.492}{Pr} \right)^{\frac{9}{16}} \right)^{\frac{-16}{9}} \right] \quad (3.5)$$

Top surface when working above ambient ($10^5 < Ra_L < 10^{10}$) [Ibid]:

$$\bar{Nu}_L = 0.82 (Ra_L)^{\frac{1}{5}} \quad (3.6)$$

Bottom surface when working above ambient ($10^5 < Ra_L < 2 \times 10^7$) [Ibid]:

$$\overline{Nu}_L = 0.54(Ra_L)^{\frac{1}{4}} \quad (3.7)$$

As can be seen from Appendix A, which includes the numerical results, a foil with a reasonable width (1.5" in this case), can be brought to temperature within a reasonable distance after entering the environmental chamber.

Alas, after the analysis, it was decided that mounting the supply reel outside the chamber would create the appearance of a source of error, reducing confidence in the data. Measuring the temperature of the foil during testing would resolve the issue, but was considered difficult because the foil was in motion. Because the associated problems were not considered insurmountable, it was decided to mount the supply spool inside the chamber rather than incur unnecessary risk.

Mount the Take-Up Spool Outside the Chamber

Mounting the take-up spool outside the environmental chamber could have fewer adverse thermal consequences. Once the foil had been used, its temperature was of no consequence to the experiment. The only concern was that the foil outside the oven would exchange enough heat to alter the temperature of the foil still being tested, but thermal modelling indicated the effect would be negligible. Sending the used foil outside the chamber also preserved the option to unceremoniously dump it into a box rather than going to the trouble of winding it back onto a spool. Nonetheless, once it was verified by Bench Level Prototype (BLP) that winding the used foil onto a spool would not present substantial difficulty, it was decided not to pursue this option.

Mount Both Spools Inside the Chamber

Mounting both spools inside the chamber presented a small packing challenge, but it was the preferred option nonetheless. With both spools inside the chamber, the neatness of the packaging would be maintained. Furthermore, the passage out of the chamber was small, and electrical and pneumatic umbilicals were already passing through it. Pushing the foil

through such a confined space might cause unpleasantness. Also, the machine was as likely to be used outside the chamber as inside it, and provision would have to be made to mount the take-up spool in both cases.

3.6 Summary

Using foil to approximate the DUTs was found to have the right mix of fidelity and practicality. The cost of using real or proxy devices was prohibitive, and simply servoing over a sheet of material could not provide sufficient surface area. Storing all the foil inside the environmental chamber alleviated concerns about experimental integrity. Programming a soak period inside the chamber was considered more reliable than relying on heat transfer processes that were not verifiable in real-time. Nonetheless, the thermal model's predictions predicted fail safe operation. Even if the thermal soak interval was insufficient, adequate time could be provided to warm up cold foil coming off the spool.

Chapter 4

APPLIED EXACT CONSTRAINT WEB HANDLING

Based on a paper to be submitted for publication in the American Society of Mechanical Engineers' Journal of Mechanical Design

TABLE 4.1 Paper Authors

Alexander H. Slocum
Massachusetts Institute of Technology
Room 3-455
77 Massachusetts Avenue
Cambridge, MA 02139

vox: (617) 253-0012
fax: (617) 258-6427
slocum@mit.edu

Alexander D. Sprunt
Massachusetts Institute of Technology
Room 3-470
77 Massachusetts Avenue
Cambridge, MA 02139

vox: (617) 253-1953
fax: (617) 258-6427
asprunt@mit.edu

4.1 Abstract

Novel web handling machine elements were devised to manipulate exactly constrained continuous media for use in a machine to test electrical contactors. Universal joints and beam type flexible couplings were employed for gimbaling and castering axes, both at standard caster radii and the roller center. A kinematic edge constraint was designed. The torque transmission properties of clamped connections were combined with the favorable kinematics of typical pinned type connections by compliantly mounting a spherical roller bearing as a pinch roller.

4.2 Introduction

During manufacture, contactors electrically connect semiconductor devices to test equipment. Despite their widespread use, the lifetime and the variables that materially influence the lifetime of contactor systems have not been systematically studied. Contactor manufacturers do test their products, but under idealized circumstances. As part of a program to better characterize semiconductor contactors by testing them against virgin material for each hit, a web handling system with the following functional requirements was developed:

- Index a 1.5" wide strip of 0.005" thick foil (0.0046" of Alloy 42 with 0.0004" 90/10 Sn/Pb cladding) in 0.025" increments (the foil is a proxy for the leads of the semiconductor devices)
- Expose a 6" section of foil for testing
- Operate for extended (> 12 hr.) periods unattended (a typical run is 20k hits)
- Operate at temperatures ranging from -50° to 150° C (-58° to 302° F)
- Fit (along with additional test equipment) inside a 22" x 20" x 19" environmental chamber

A web¹ is “a strip of flexible material whose width is much greater than its thickness and whose length is much greater than its width” [Blanding]. The principal challenges are getting the web headed in the proper direction and stabilizing its motion in that direction. By analogy, think of a car on an perfectly straight and empty desert highway. Theoretically, if the car is placed on the road parallel with the edges, it could travel forward indefinitely and remain on the road, but because the alignment of the car’s wheels can never be perfect (for that matter, neither can the edges of the road), some feedback mechanism must be provided to steer the car back to the center of the road when it begins to wander [Blanding]. Compliant webs, e.g. rubber and leather belts, can be guided by crowned rollers, but stiff webs like metal foils, photographic film, and paper, must be guided by other means.

1. Searching for literature was considerably complicated by the concurrent use of the term as slang for the World Wide Web (WWW)

Such means typically consist of some *stable* arrangement of fixed rollers, castored rollers, gimbaled rollers, and edge constraints. Those familiar with the operation of still and motion cameras and movie projectors will know that stiff webs can also be guided by sprocket holes and similar devices. Manufacturing metal foil with analogous features for such a low volume application was dismissed as impractical, and an effort was begun to design a kinematic web handling system.

4.3 Kinematic Web Handling Background

4.3.1 Exactly Constraining Webs¹

In three dimensions, rigid bodies have six degrees of freedom, three translations and three rotations. In two dimensions, rigid bodies have three degrees of freedom, two of translation and one of rotation. A body is exactly constrained if the number of its constraints and the number of its *desired* degrees of freedom sum to the number of degrees of freedom inherent to the space in which it exists. Though they move in three dimensions, webs are two dimensional objects, and two constraints will exactly constrain them to move along a particular path. A web's path in three space is determined by the spatial arrangement of rollers, but a web's stability in its own two dimensional space is determined by the type of rollers. Practical web handling equipment leaves the web with one degree of freedom, for static webs are of limited use.

There are two kinds of web constraints: rollers and edge constraints. A pair of rollers or a roller and an edge constraint exactly constrain a web. The intersection of the axes of the roller pair or the intersection of the axis of the roller and the normal to the edge of a web at the edge constraint (Figure 4.1) is the web's instant center of rotation. Because it is unstable, the two roller arrangement is seldom used. For unless the rollers can be perfectly aligned to each other and the web perfectly aligned on them, either of which is an impossi-

1. As the principal source on kinematic web handling, Blanding's book "Exact Constraint: Machine Design Using Kinematic Principles," is the primary source for the theory in this summary.

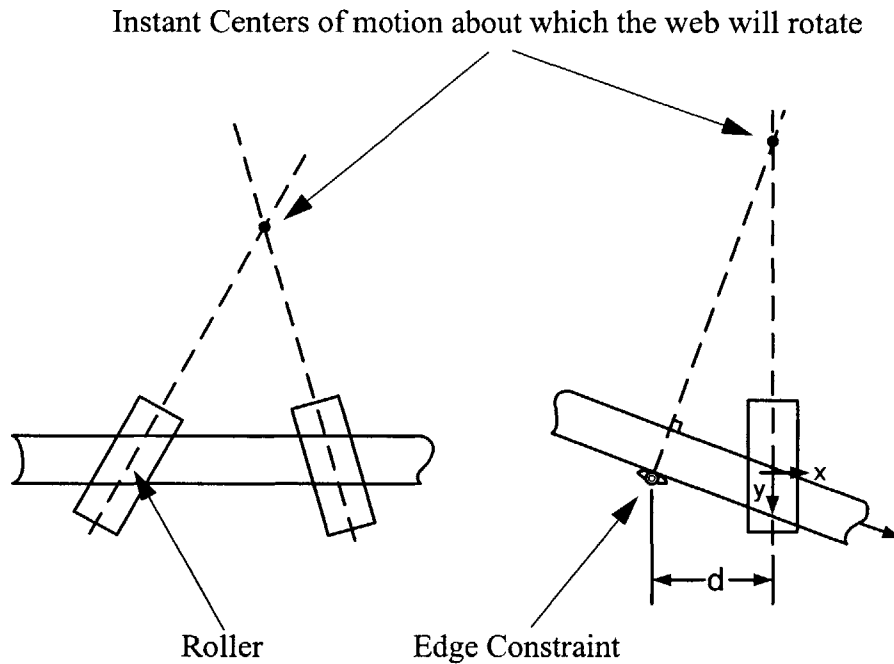

Figure 4.1 Two methods of exactly constraining a web.

bility, the web will eventually run off the rollers. Because the instant center of the roller-roller arrangement is fixed by geometry, any initial imperfection is amplified over time.

The roller and edge constraint arrangement is preferred because it is stable and because many web manipulations require a reference edge. The arrangement is stable because its instant center is not fixed (Figure 4.2), but varies as the cross track position of the foil changes. If the web is conveyed in the direction indicated, the normal to the edge of the web at the edge constraint will rotate until the intersection with the roller's axis line has moved out to infinity. With the instant center at infinity, only pure translational motion can occur. The cross track position of the web, (y), decays exponentially as the web moves downrange (x):

$$y = y_0 e^{-\frac{x}{d}}. \quad (4.1)$$

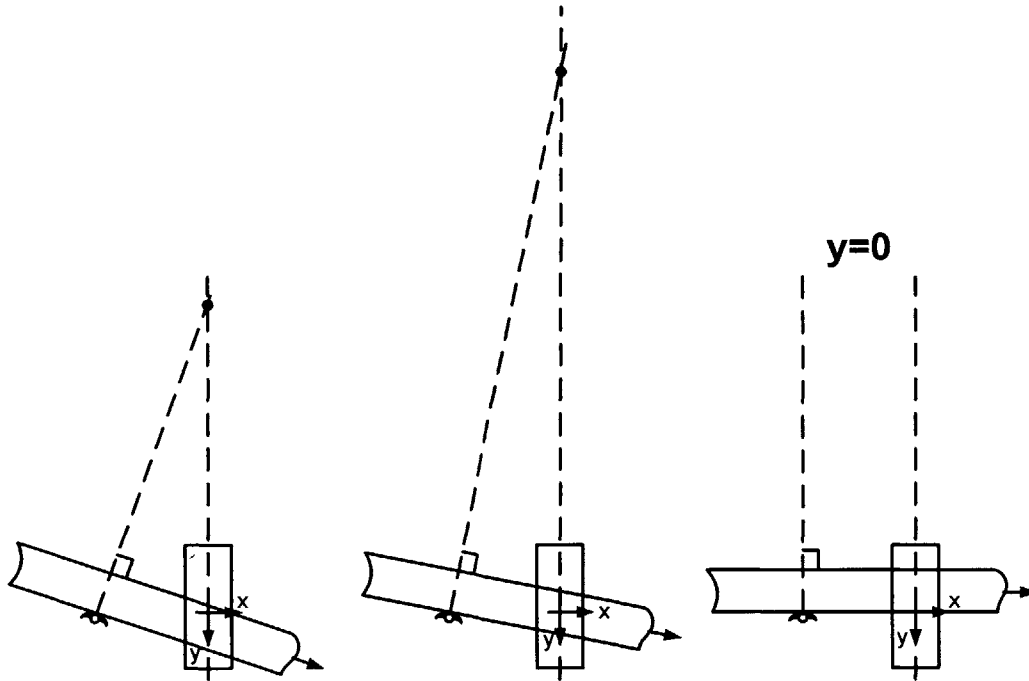

Figure 4.2 Decay of cross track error as the instant center moves closer to infinity

Adding constraints, e.g. additional rollers, creates multiple instant centers, and forcing a web to rotate about multiple instant centers can cause tearing, wrinkling, and other undesired conditions. But because practical web handling systems have more than one roller, some way must be found, which is the role of zero constraint rollers.

4.3.2 Zero Constraint Rollers

Zero constraint rollers can be added to an already exactly constrained web handling system without creating a redundant constraint. If the zero constraint roller in Figure 4.3 were a regular roller, the web would have two conflicting instant centers, with all the attendant consequences. There are three kinds of zero constraints: nonrotating shoes, axially compliant rollers, and castered rollers (Table 4.2).

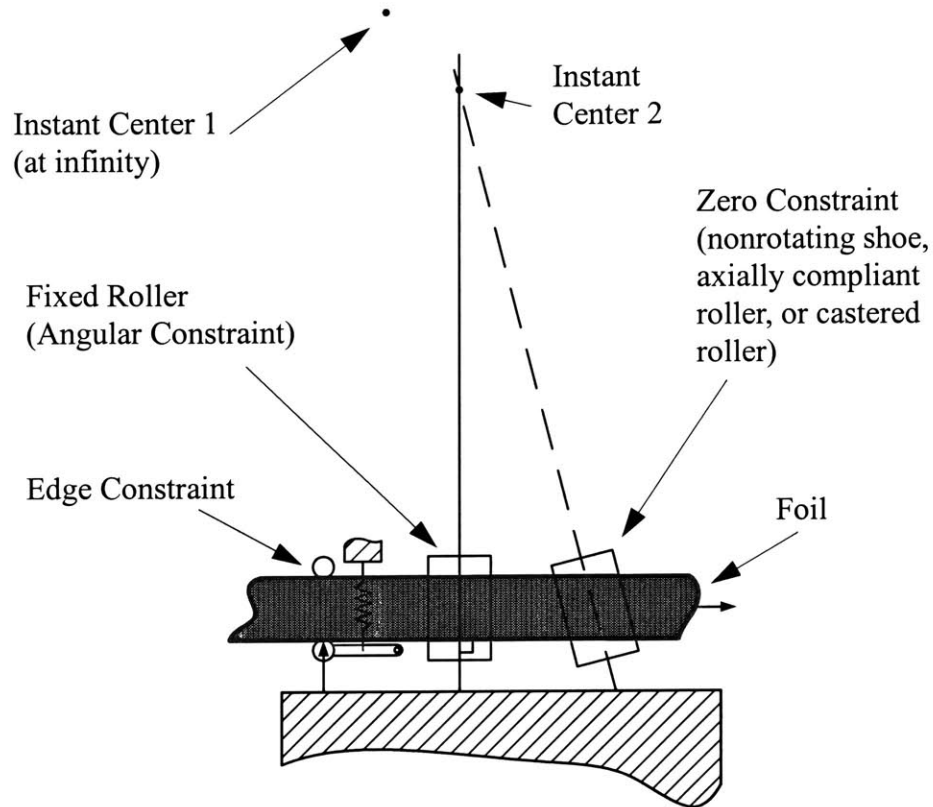
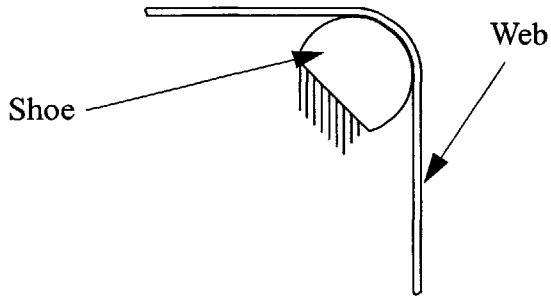
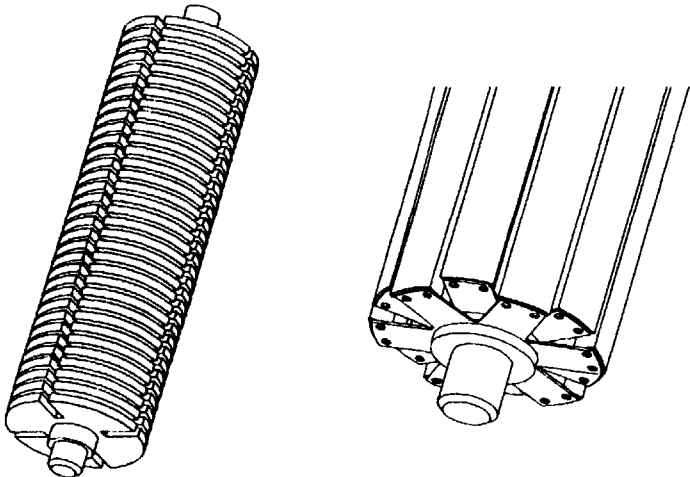
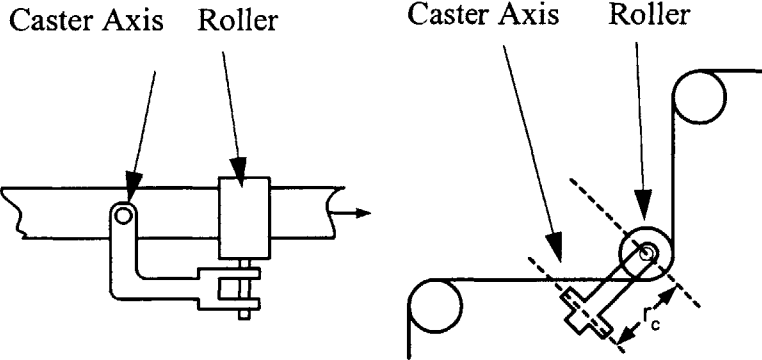

Figure 4.3 Adding an additional roller can cause over constraint if the new roller is not carefully chosen. Overconstraint manifests itself as multiple instant centers of rotation, which can destroy a web. The appropriate web plane diagram symbols have been overlaid on this figure.

Nonrotating Shoes

Nonrotating shoes are rollers that cannot rotate. The web must slide over them, breaking the friction lock normally present between a rotating roller and the web. The absence of this connection makes the web freer to slide in the cross-track direction, preventing axial constraint. Nonrotating shoes were a poor fit for the contactor testing machine, because the sliding contact between the shoe and the web would be a source of harmful lead particles. Implementing an air bearing nonrotating shoe was also unattractive, due to the inconvenience of conditioning the air prior to exhausting it inside the environmental chamber. No experimentation was done with nonrotating shoes, and they are mentioned here only for completeness.

TABLE 4.2 The three types of zero constraint rollers

 <p>Shoe</p> <p>Web</p>	<p>Non-Rotating Shoes, the flat grounded edge indicates</p>
	<p>Axially Compliant Rollers, US Patents #4,221,480 (left) and #5,244,138 (right), (images from Blanding)</p>
 <p>Caster Axis Roller</p> <p>Caster Axis Roller</p>	<p>Castered Rollers - The caster axis is normal to the roller axis and parallel to the angular bisector of the angle formed by the foil enter and leaving the roller.</p>

Axially Compliant Rollers

Axially compliant rollers (Table 4.2) are stiff in the radial direction, but compliant axially, thereby facilitating rolling contact without overconstraint. The axial compliance must be of a particular kind, however. “The roller surface will freely move in the crosstrack direction as demanded by the web and will then restore itself to its initial position after the web has left contact.” The fanciful mechanism in Figure 4.4, will not work. It cannot return to

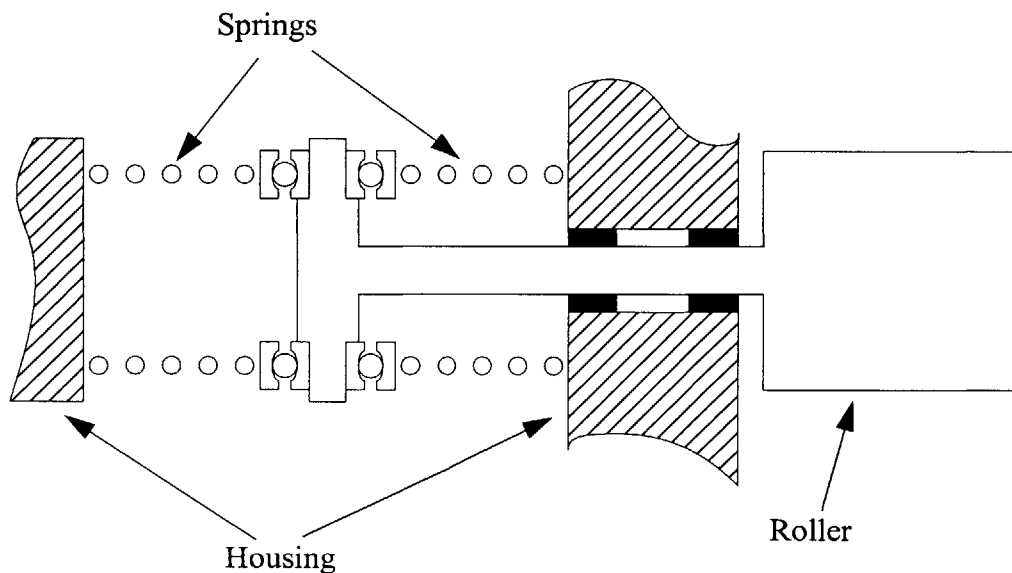

Figure 4.4 A fanciful axially compliant roller that is unworkable because it has only one roller surface, and can therefore never leave contact with the web, preventing it from resetting.

its initial position because its single surface will never lose contact with the web. A pair of rollers featuring the appropriate kind of axial compliance is shown in Table 4.2. The rubber disks of the roller on the left bend axially (while maintaining their radial stiffness) to accommodate misalignment of the web. The roller on the right is composed of sheet flexures serving the same purpose. These rollers could have been used, but neither kind was readily available. Several vendors were contacted without success. Even if a vendor had been found, the lead time for rollers of appropriate diameter and width and capable of

withstanding temperatures of up to 150°C would likely have been unacceptable. And if availability had not been a problem, the rollers would have only been useful for the idler roller. Some other solution would have had to be found for the spools.

Castered Rollers

Like axially compliant rollers, castered rollers avoid overconstraining the web by providing an additional degree of freedom between the roller and the machine frame. As with casters on shopping carts and dollies, an axis of rotation is added upstream of the roller with respect to the web motion (Table 4.2). Optimally, the caster axis is also parallel to the bisector of the angle formed by the web when it enters and leaves the roller (Table 4.2). This second requirement and gravity greatly restrict the possible configurations of real web handling mechanisms.

4.3.3 Gimballed Rollers

By twisting the two-dimensional plane the web inhabits, gimballed rollers create joints that allow for the re-direction of the web in three dimensions (Figure 4.5). A gimbal axis is

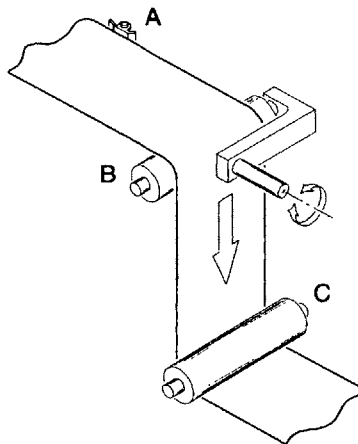

Figure 4.5 “B” is a gimballed roller (figure reproduced from Blanding)

similar to a caster axis, but instead of being parallel to the angle bisector, it is parallel to the incoming web span. By allowing the A-B section to twist, the roller at C no longer “sees” the constraint at A. From roller C’s perspective, gimballed roller B becomes an implied axial (or edge) constraint for which roller C provides the attendant angular constraint (Figure 4.6). This is the equivalent of creating a “joint” in the two dimensional space the web inhabits. The optimal wrap angle of the web around a gimballed roller is 90° , but between 45° and 135° is acceptable. Wrap angles of 180° and 0° will not work.

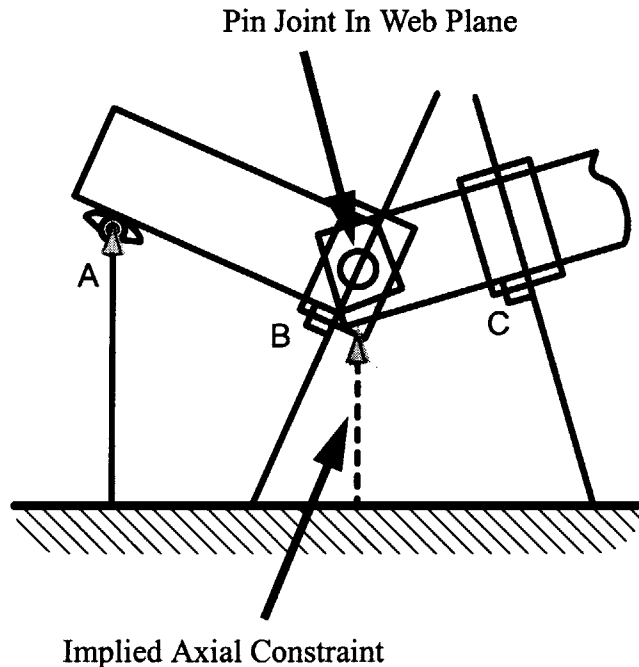

Figure 4.6 By taking advantage of the three dimensional twist compliance of section A-B, the gimballed roller (B) creates a joint in the web plane. The section A-B is exactly constrained by the edge constraint at A and the angular constraint at B. The section B-C is exactly constrained by the implied axial constraint at B and the angular constraint at C. The overlaid web plane symbology is explained below.

4.4 Concepts

After preloading on kinematic web handling theory, brainstorming produced the two arrangements shown in Figures 4.7 and 4.8. Contactors are typically plunged down into the Device Under Test (DUT). Doing so ensures that any particles or other debris gener-

ated during testing are carried away with the devices. The two arrangements sought to continue this practice, preserving experimental fidelity.

4.4.1 First Concept

The first concept bears some resemblance to a movie projector (Figure 4.7). Both spools and the idler roller are gimbaled and castered. The indexing roller is fixed. When combined with the edge constraint, the web is exactly constrained. Special care was taken to create a large wrap angle around the index roller. Torque is transmitted to the foil by the capstan effect, so a greater wrap angle increases the torque that can be transmitted to the foil. Foil tension is maintained by a torque source attached to the take-up spool and a slip clutch coupled to the supply spool. A stepper motor drives the index roller to break the equilibrium between the torque source and the slip clutch and advance the foil.

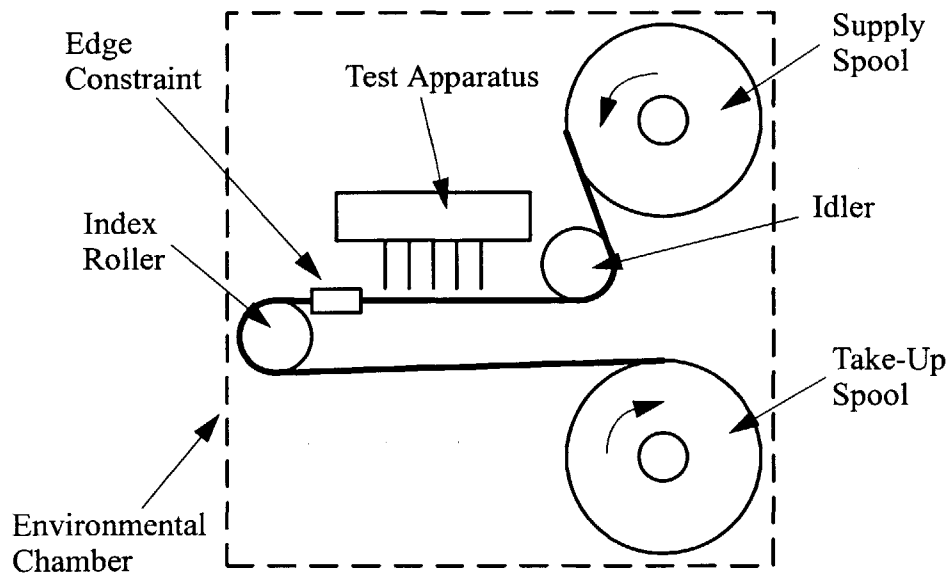

Figure 4.7 “Movie Projector” style arrangement

The requirement that the web be indexed in fixed steps could also have been met by driving the take-up spool with a servo motor and hanging an encoder on the fixed “index” roller, but it was felt that this solution did not increase mechanical simplicity and would

have considerably complicated the control system. The index roller was sized such that driving the stepper discretely in half step mode produced the desired interval of foil advance.

4.4.2 Second Concept

The second concept is very similar to the first from the perspective of the foil (Figure 4.8). As said before, webs are two dimensional structures, and despite the changes in the three dimensional positions of the various spools and rollers, the order the web passes through them is the same, and the web distances between them are roughly equal. The spools and the idler roller are once again gimbaled and castered, while the fixed index roller and the edge constraint combine to exactly constrain the foil. Also as in the first concept, a torque

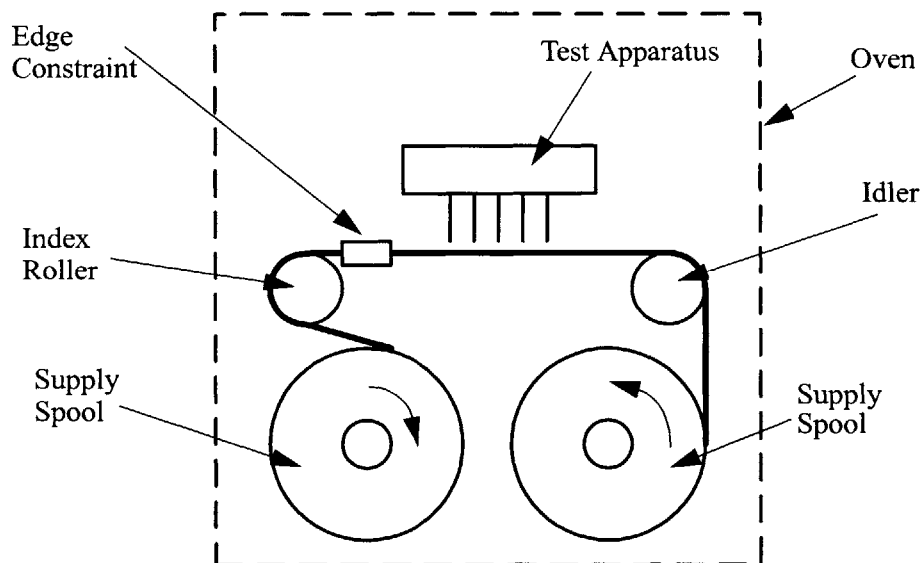

Figure 4.8 Second, and more space efficient arrangement

source is attached to the take-up spool, a slip clutch is coupled to the supply spool, and a stepper motor driving the index roller breaks the equilibrium.

4.4.3 The Edge Constraint

The edge constraint was not a part of either concept from the beginning. Both arrangements proved to be stable, though not in the way originally believed. It was thought, despite Blanding's warning, that the flanges on the sides of the spools would serve as edge constraints. Fortunately, such was not the case. If it had been, both arrangements would have been unstable. As will be seen, when a Bench Level Prototype (BLP) was constructed, the web found its own edge constraint.

4.4.4 Web Plane Diagram

Web plane diagrams are constructed to check web handling systems for overconstraint and stability. In Blanding's system, edge constraints are symbolized as arrows from ground, indicating that they fix the distance from the web edge to the machine frame (but not the angle). Fixed rollers are indicated by a solid line from the machine frame to the web, and are linked to the web edge with a right angle symbol, for when used in conjunction with an edge constraint, the web's edge will be orthogonal to the roller's axis. Zero constraints are represented by dashed lines and can intersect the web at any angle. The dashed line indicates that they can intersect the web at an arbitrary angle and at an arbitrary distance from the machine frame. Gimballed rollers are represented like a fixed roller, but with the addition of a pin joint, which allows the web to change direction with respect to the frame (Figure 4.6). To emphasize that they will not be perfectly aligned in the hardware, the lines representing constraining rollers are deliberately drawn non-squarely, and the foil is represented at an arbitrary angle with respect to ground. Different elements can be combined in the diagram by combining their symbols. A castered and gimballed connection is represented as a dashed line (without a right angle symbol) and pin joint, and would not apply an angular constraint to the web. The constraints in Figure 4.3 have been overlaid with the appropriate web plane symbology.

As mentioned before, the two configurations are essentially the same from the web's perspective, so a single web plane diagram (Figure 4.9) will suffice for both. Initially, the

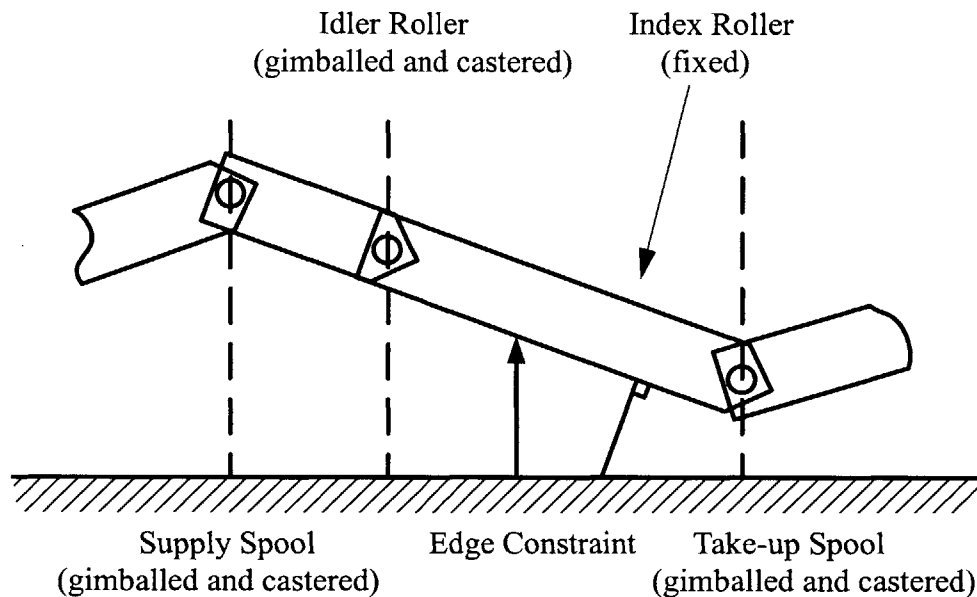

Figure 4.9 Web Plane diagram for both arrangements, mis-alignment is deliberately exaggerated to emphasize any overconstraint.

edge constraint was omitted. The literature did not describe the proper treatment of flanged spools, and it was incorrectly assumed the spools' flanges would provide the necessary crosstrack constraint. The correct treatment of spools is to assume the web emanating from them is fully constrained "upstream" of them. Immediately after being wound off the spool, the web can neither slide in the cross track direction or change its angle with respect to the spool. Because the spools are gimballed and castered, the edge constraint is necessary to properly constrain the web between them. The diagram reflects these changes. Note that the gimbaling of the idler roller appears to be unnecessary. It is not necessary for the foil to change direction there. Blanding says little about underconstraint of webs, which this appears to be, but a possible explanation will be put forth later.

4.5 First Bench Level Prototype

4.5.1 Universal Joints

Despite the deliberate skewness of web plane diagrams, the gimbaling and castering motions necessary to facilitate self-alignment are quite small. Flexures are a natural choice to accomplish such motion. But manufacturing is greatly complicated by the necessity of making the gimbaling and castering axes perpendicular. The best rapid prototyping tool available for making flexures, abrasive waterjet cutting, works in two dimensions. A minimum of two parts would therefore have to be made for each joint. While not a problem in itself, this cascading of joints consumes precious space inside the environmental chamber.

Brainstorming about machine elements that might already include a pair of cascaded orthogonal axes of rotation, turned up the universal joint. Mounted as in Figure 4.10, the

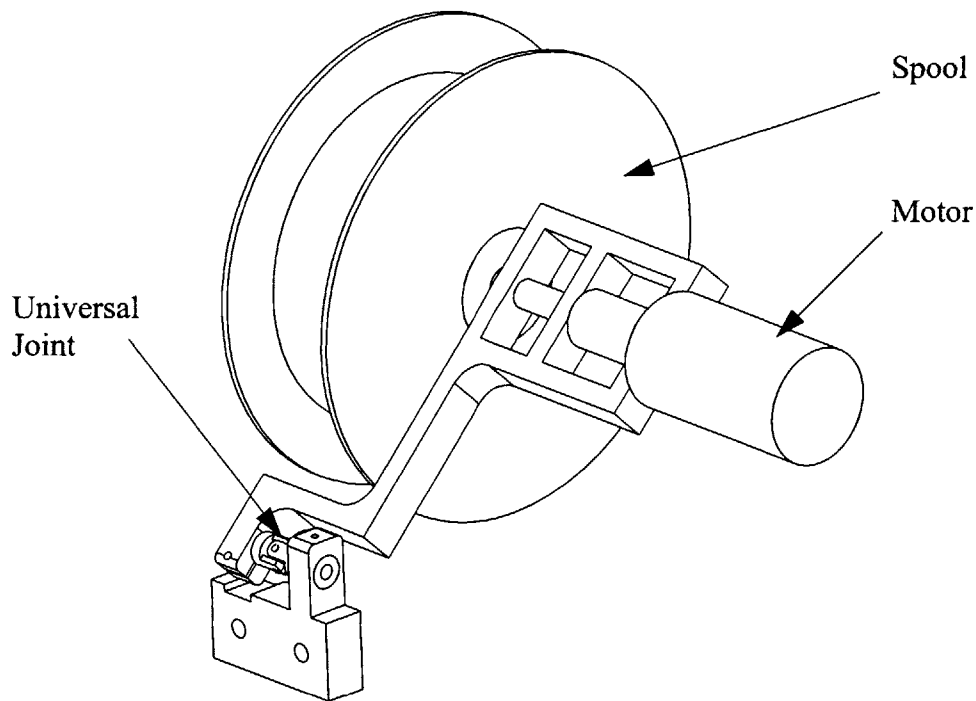

Figure 4.10 A universal joint mounted to provide gimbaling and castering. Note the length of the caster radius, i.e. the distance between the universal joint and the axis of rotation of the spool.

universal joint creates gimbal and caster axes. Gimballed and castered mounts were designed for the spools and the idler, and a fixed mount was designed for the index roller. These elements were assembled into the second arrangement concept (Figure 4.11), but in this initial configuration, the BLP did not function. The arrangement relied on the tension in the foil to hold the spools (weighing 10 lbs. each) upright. It may be feasible to apply enough tension to support the spools in that manner, but it proved to be impossible with this BLP.

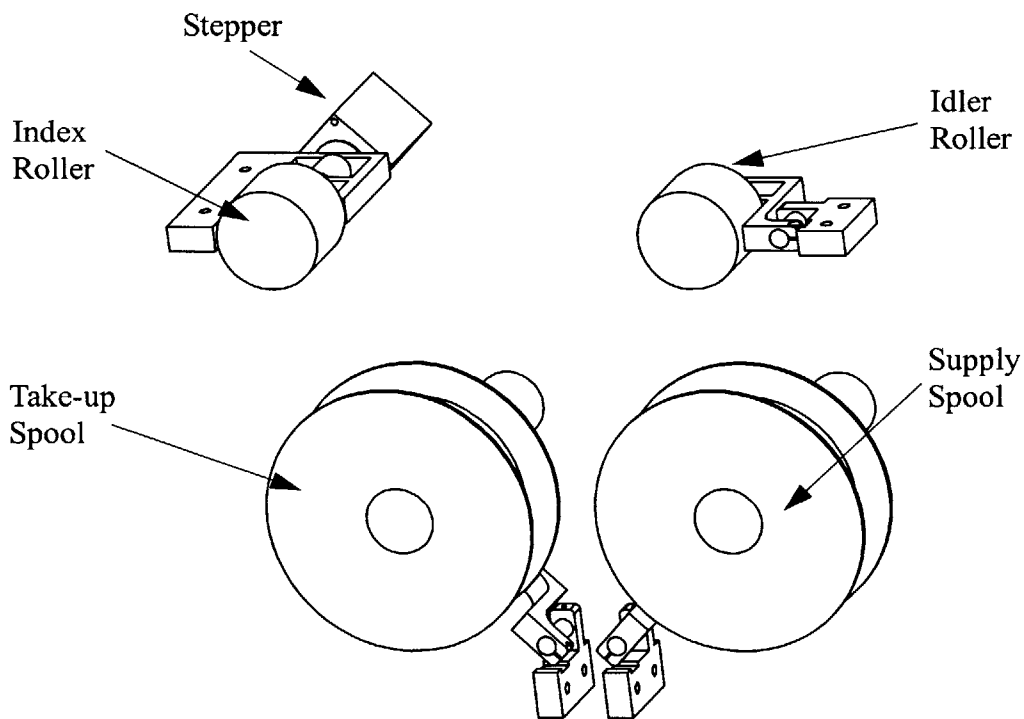

Figure 4.11 The plan for implementing arrangement two in hardware. Note the gravity defying positions of the supply and take-up spools. The frame is not shown.

4.5.2 Making it Work

The situation was salvaged by the modular design of the BLP. By re-configuring the BLP into the movie projector arrangement, the effect of gravity was effectively reversed. The BLP was re-configured rather than being turned upside down because contactors must be

plunged down to prevent debris contamination. Counterweights were also added to move the center of gravity of the gimbaling and casting assemblies to the center of the universal joint. Balancing the motors attached to the spools required a considerable amount of weight, but the results can be seen in Figure 4.12. Though careful balancing was required,

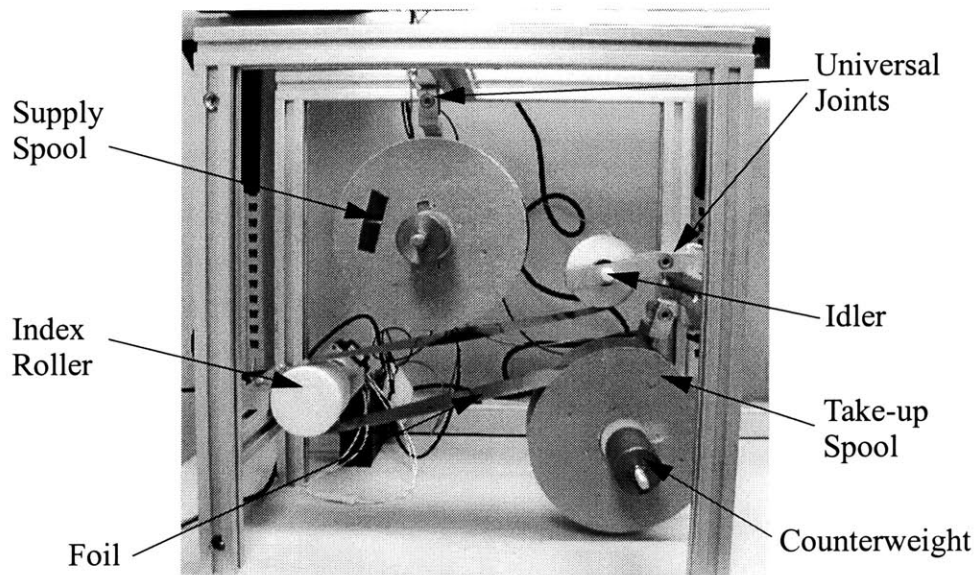

Figure 4.12 Slightly modified “movie projector” arrangement. Note the counterweights and that gravity and foil tension are loading the universal joints in tension.

the system worked. Tension was created between the powered DC motor on the take-up spool and the shorted DC motor fixed to the supply spool. The stepper motor coupled to the index roller broke the equilibrium between the two motors and advanced the foil.

4.5.3 Pseudo-Stability

There was a problem: over a number of indexes, the take-up spool was slowly pulled out of position, and the foil would climb the flange. The solution was to limit the range of the spool’s self-alignment mechanism. After the spool hit the stop, the intermittent motion of

the foil advance would work the foil back down between the flanges for the cycle to start again. The system worked, but these behaviors did not inspire confidence.

At the idler roller, the cause of the problem was revealed. While it rolled well and changed the course of the foil as intended, the idler did not self-align. Rather, it had a tendency to fall off to one side just as the take-up spool did, but less dramatically. When it moved to one side, the edge of the foil would come into contact with structure of the mount (Figure 4.13). The foil was finding its own edge constraint! Returning to an earlier anal-

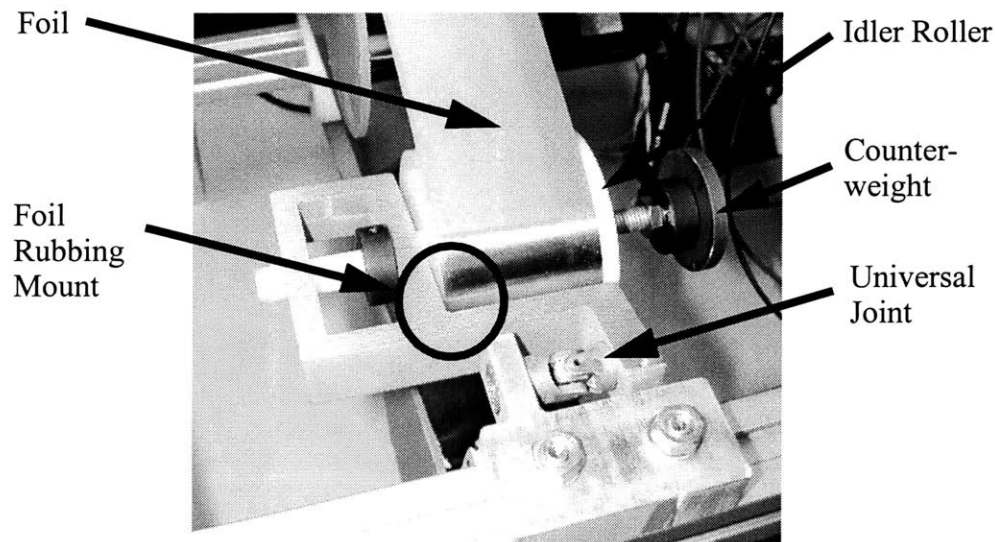

Figure 4.13 The foil finding its own edge constraint

ogy, the road had been made perfectly straight, but because it did not know where the shoulder was, the car had a tendency to depart the road anyway. The web was doing the equivalent of riding along against the guardrail, for it was only neutrally stable. This revelation prompted the design and installation of an edge constraint.

4.5.4 Edge Constraint

The edge constraint was designed with kinematic principles. The evolution of the design is illustrated in Table 4.3. The constraint holds the foil between a pair of cam followers, one

TABLE 4.3

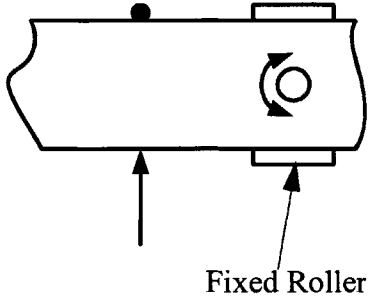
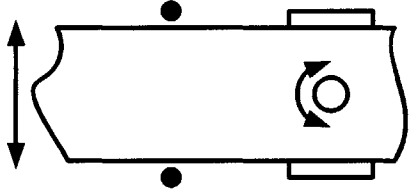
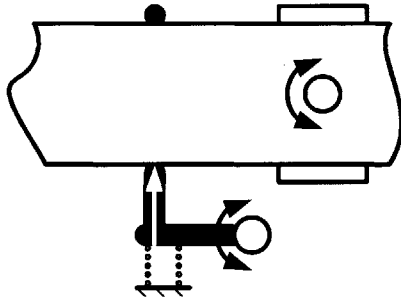
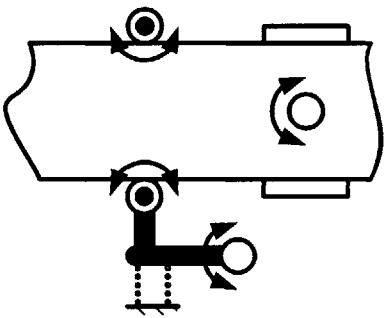
<p>1</p>  <p>Fixed Roller</p>	<p>Blanding's Idealized Edge Constraint: Web may pivot about the fixed roller. Edge constraint is shaped such that force may only be applied normal to the edge of the web (e.g. a circle). Nesting force (arrow) is provide by unspecified means.</p>
<p>2</p> 	<p>Nesting force cannot be supplied by a rigid structure. The web will either be underconstrained (as shown here) or overconstrained (pinched)</p>
<p>3</p> 	<p>Nesting force is correctly applied using a spring loaded arm. The edge constraint and the fixed roller now exactly constrain the web. The spring force must be chosen with care or the web will buckle</p>
<p>4</p> 	<p>The rigid circular sections have been replaced with rotating cam followers. In addition to greatly reducing friction, the addition of the cam followers prevents particle generation</p>

fixed, and one on a spring actuated arm (Figure 4.14). A third cam follower kept the foil in

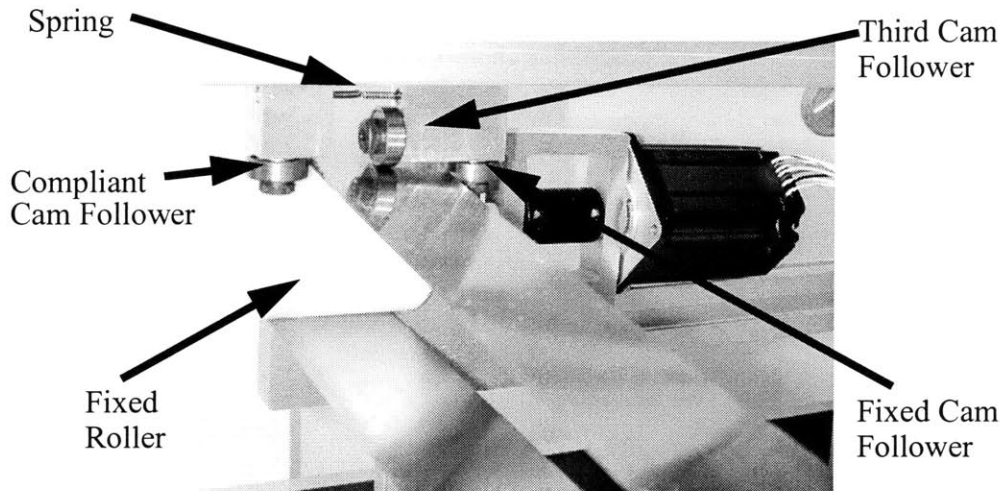

Figure 4.14 The kinematic edge constraint. A cam follower on a spring arm nests the web against the fixed cam follower to create an edge constraint. The third cam follower turned out to be superfluous.

the plane of the first two.

Some experimentation was required to find a spring that did not buckle the foil, but with that done, the edge constraint was a complete success. The idler roller now self-aligned properly, and more importantly, the foil no longer tended to climb the flange of the take-up spool. The hard stop restricting the take-up spool's range of motion was no longer necessary. The third cam follower mounted in the middle of the foil was not necessary either. It seldom contacted the foil, and was eliminated from the final design. Given there was no need to alter the path of the web as it passed through the constraint, the fixed roller was a much more effective means of guiding the foil between the other two cam followers. Figure 4.3 includes a schematic representation of the final version.

4.5.5 Limitations of the Concept

Despite the success of the BLP, the web handling problem had not been solved satisfactorily. The counterweights worked, but were unwieldy. And because the motors would

have to be thermally insulated, the counterweights would only become heavier (Figure 4.15). The weights also made the spools that much heftier and harder to load. And

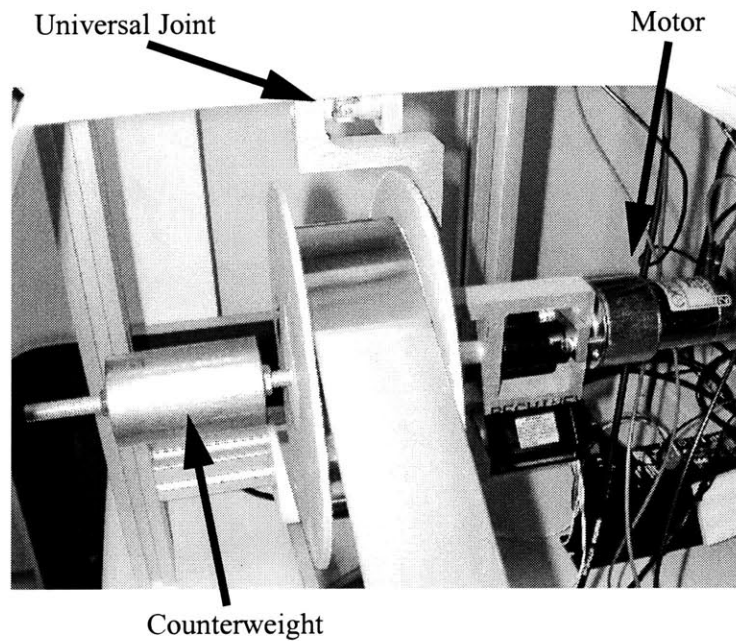

Figure 4.15 Spool assembly, note the size of the counterweight.

though the concept could likely be made to work, the space consumed and the constraints imposed by the universal joint mounting system made fitting everything inside the environmental chamber quite challenging. Finally, although it was not a technical shortcoming, the whole machine tended to tilt and sag when foil was not loaded. Desire for a more elegant solution prompted the second and third bench level prototypes.

4.6 Second Bench Level Prototype: Internal Universal Joints

The problems with the first bench level prototype would be solved if the universal joints were moved to the center of the spools and the roller. The motors would no longer gimbal and caster with the spools and the roller, thus greatly reducing the size of any counterweights. Shrinking the counterweights would greatly ease foil loading, and because the self-alignment mechanism would be balanced when unloaded, the machine would no longer sag. Finally, the space consumed by the long gimbaling and castering axes could be reclaimed.

Blanding did not recommend reducing the caster radius to zero, however: “The exact value of the caster radius is not critical,” but “the caster radius (the distance between the caster axis and the roller axis) should be about the same order of magnitude as the length of the roller (or the width of the web).” Furthermore, the roller would come into alignment as a “decaying exponential function of the caster radius:”

$$y = y_0 e^{-\frac{x}{r_c}}. \quad (4.2)$$

As the caster radius, (r_c , Table 4.2), approaches zero, the distance the foil has traveled (x , Figure 4.2) before alignment is complete (the equivalent of five time constants) approaches zero (Figure 4.16). Though this result may mean that the roller could statically self-align itself with the web, it was not clear. However, since the advantages of a system thus constructed were so great, a second (and later a third) bench level prototype was tested.

The cascaded axes of the universal joints were placed at the center of the idler roller and spool cores (Figure 4.17). There is no equivalent to the caster radius for the gimbaling axis, so the second BLP was not different from the first in that regard. Material was removed from the outside ends of the rollers and cores to make their centers of mass coincide with the axes of the universal joints. To accommodate inevitable imbalances, a threaded rod was fixed to the outside end to position counterweights.

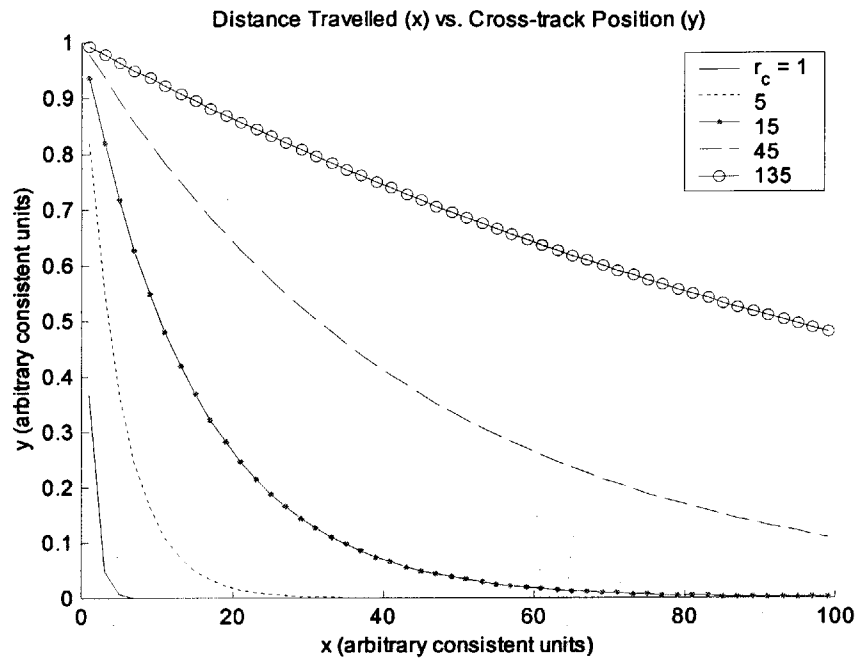

Figure 4.16 A cross track position of zero indicates alignment is complete. Reducing the caster radius to zero resulted in instantaneous alignment of the roller. Determining if this was a problem was one goal of the second bench level prototype.

The BLP functioned, but required a disappointingly large amount of fine-tuning. Less misalignment could be accommodated than in the previous prototype, and care had to be taken to assemble all the rollers in the same plane. Reducing the caster radius to zero did not appear to cause any problems, for the rollers did self-align, but misalignments that would have been accommodated by the first BLP were enough to ground the universal joint on the inside of the roller. The small clearance between the universal joint and the inside of the roller was likely at fault, but any disappointments with the second BLP were swept away by the success of the third.

4.7 Third Bench Level Prototype: Internal Flexible Couplings

During the experimentation with the first BLP, it was realized that the universal joints could be replaced with beam type flexible couplings. And the restoring force inherent to

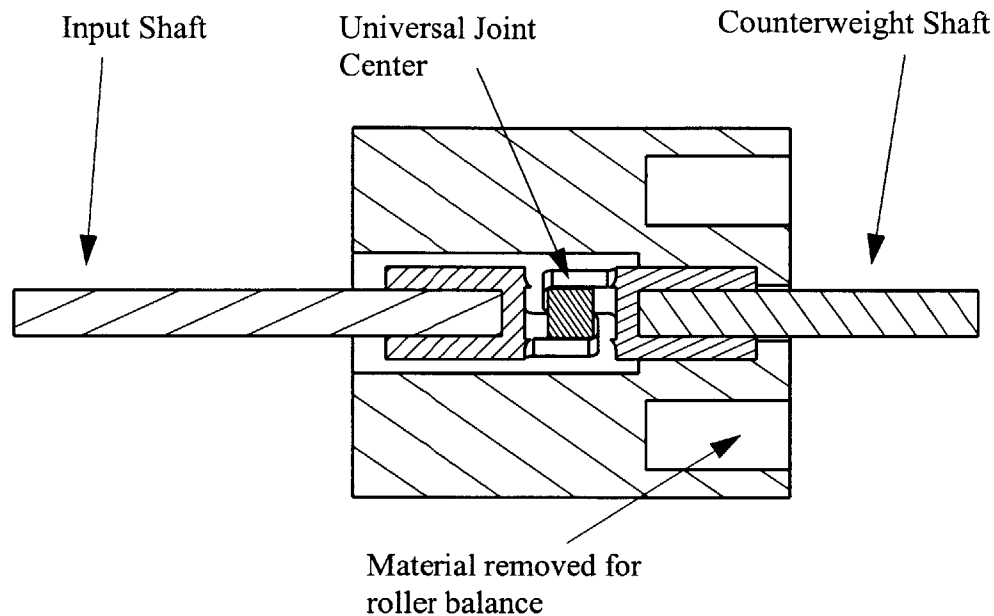

Figure 4.17 Spool core with internal universal joint providing gimballing and castering axes.

the flexible coupling held out the intriguing possibility of further simplifying the design by the eliminating the counterweights. Compare the flexible coupling based mount in Figure 4.18 with the original gimballing and castering mount in Figure 4.10. The concern was the flexible coupling's two additional degrees of freedom.

As illustrated in Table 4.4, flexible couplings deform in three relevant ways. The gimbal and caster axes are created by the coupling's accommodation of angular misalignment. Depending on the reference frame, this represents rotation about one or two axes. The other misalignments accommodated are shaft parallelism and axial misalignment. It was unknown what effect the coupling's ability to accommodate shaft parallelism misalignments would be. Such a deformation could be thought of as a motion orthogonal to the two dimensional plane inhabited by the web, i.e. the equivalent of simply translating the roller, which is known to have no effect for small motions, but it was not certain. That the amount of parallel misalignment accommodated by couplings is typically on the order of a quarter millimeter was also a source of confidence. Nonetheless, determining the impact on system performance of parallel misalignment would be a major goal of the BLP.

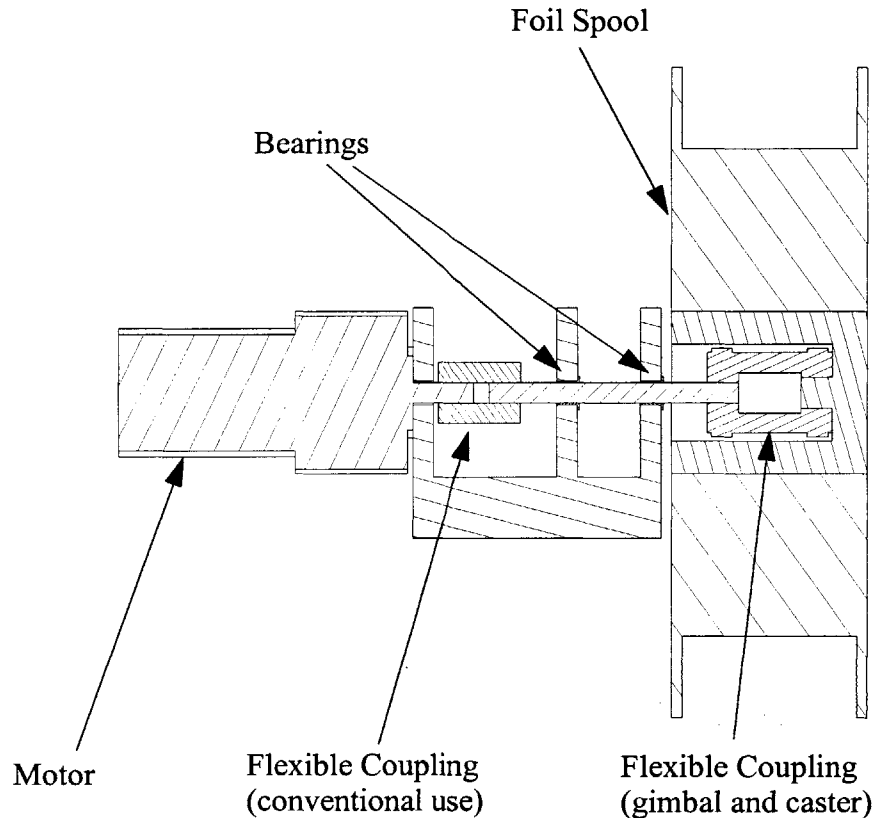
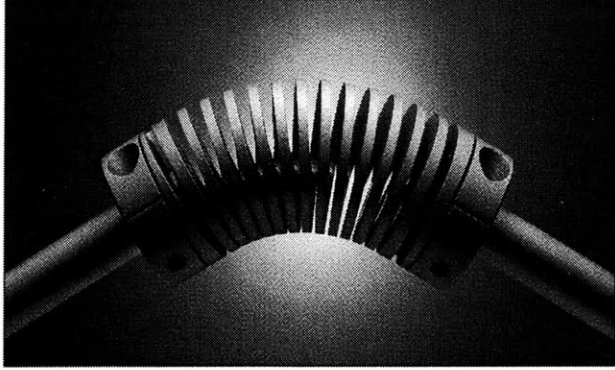
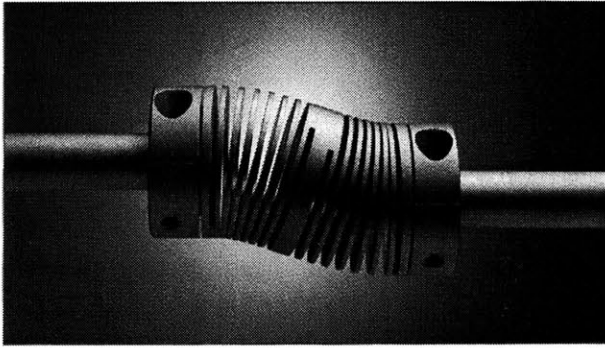
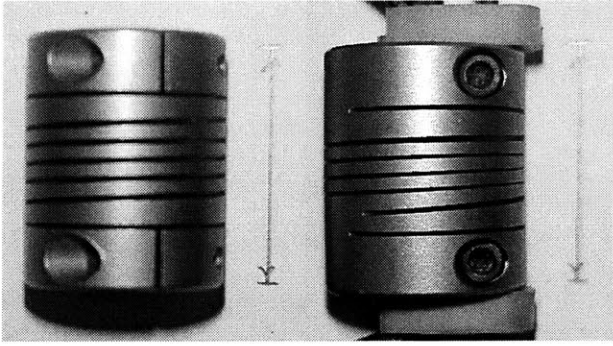

Figure 4.18 Spool mount based on a flexible coupling. Functionally equivalent to the hardware in Figure 4.10.

More was known about the impact of the coupling's accommodation of axial misalignment. Initially, it was tempting to think of the coupling's axial motion as a new way to facilitate axial compliance, but some reflection revealed this to be incorrect. The coupling's axial motion is exactly like that of the fanciful mechanism in Figure 4.4. A zero constraint roller can not be created in this fashion. Knowing that a motion will not perform a service, is not the same as knowing it will not perform a disservice, but like parallel misalignment, it was thought that the displacement would be small. According to catalog data, typical couplings can accommodate only a few tens of thousandths of an inch of axial misalignment without damage. It was believed that such small displacements would not present a problem.

TABLE 4.4 Modes of Helical Coupling Misalignment.

	<p>Angular Misalignment: two orthogonal angular misalignments create gimbaling and castering axes (photograph reproduced from the catalog of the Helical Products Company)</p>
	<p>Parallel Misalignment: equivalent to slightly changing the position of a roller on the frame. Has no alignment effect (photograph reproduced from the catalog of the Helical Products Company)</p>
	<p>Axial Misalignment: thought to be a form of axial compliance, but actually equivalent to the mechanism in Figure 4.4, and therefore does not create a zero constraint roller</p>

As shown in Figure 4.19, the center of stiffness of each flexible coupling was aligned with the center of its roller. Material was removed from the outside end of each roller to make the roller's center of mass coincident with the coupling's center of stiffness.

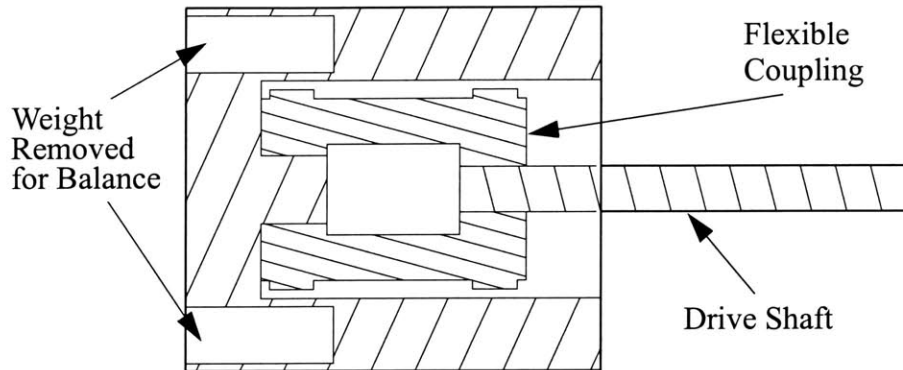

Figure 4.19 Section of a spool core based on flexible coupling

The flexible coupling BLP worked flawlessly (Figure 4.20). Practical concerns dictated

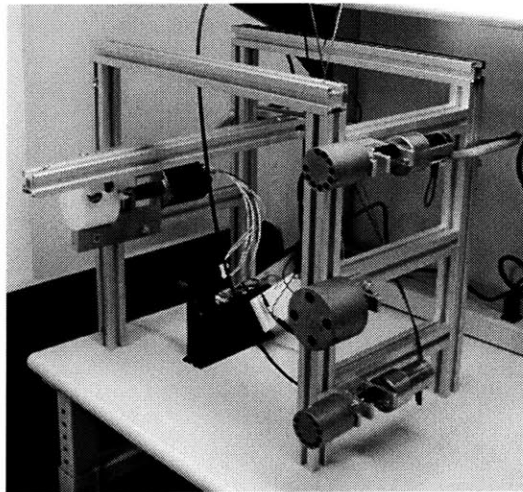

Figure 4.20 The flexible coupling bench level prototype without foil loaded.

the implementation of the film projector arrangement, but by this time, experience suggested arrangement two would also work, so because of its packing advantages over the film projector arrangement, it was chosen for the final version.

Constructing a web plane diagram (Figure 4.21) of the second and third BLP's that doesn't include a castered joint at the flexible couplings makes it clear that castering is taking place. The diagram contains multiple incidences of the web changing course between roll-

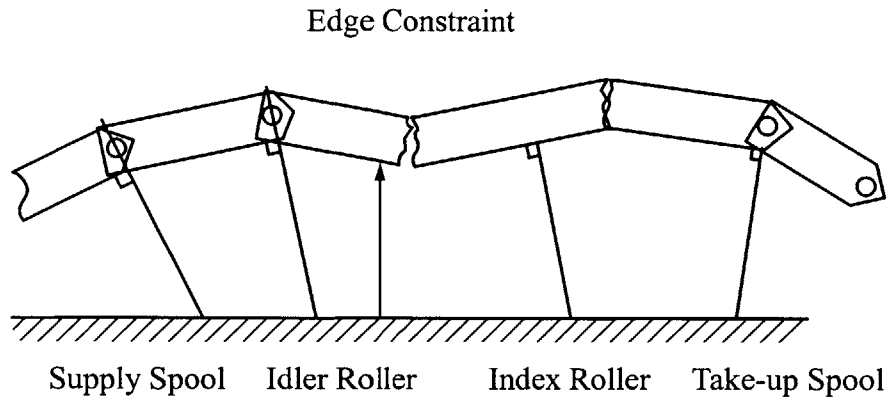

Figure 4.21 Web Plane Diagram of BLPs two and three that does not include castering at the flexible couplings. Note the “tears” in the web where it is overconstrained.

ers, something that it cannot do. If castering were not occurring at the flexible couplings, the web would be overconstrained, and the system would not work. Castering with a caster axis of zero suggests that gimbaling and castering may really be a mechanism to make the axes of all the rollers parallel.

4.8 Final System

Due to the extensive prototyping that preceded it, the final system worked almost perfectly from the beginning. The only significant problem encountered was not related to the web handling kinematics and had not been tested for by any of the prototypes, but it did have a web handling solution, so is included here.

It was not critical that the mechanism advance the web by precisely 0.025" each index, but it was essential the foil move enough that the probes contact virgin material each index. To

detect-foil motion, a sensor was hung on the idler roller's shaft. During the initial system shakedown, this failure mode was a significant problem. The cause was slippage between the web and the index roller. The wrap angle around the index roller had mistakenly been validated with quasi-static assumptions. The friction lock between the web and the index roller could not transmit enough force to rapidly accelerate the large inertia of a full supply spool. Increasing web tension was a solution, but was not attractive from a robustness standpoint.

Instead, a pinch roller was designed to clamp the web to the index roller. Like reducing the caster radius to zero, this was something explicitly discouraged by Blanding: "Such a clamped connection completely constrains the web in two dimensions. Any additional constraints would be an overconstraint." The testing machine's web was already fully constrained, so a clamped connection must be avoided, but Blanding offered some encouragement as well: "If the pressure roller were relatively short in length and centrally located relative to the platen roller, the "pinned" model might be appropriate." The machine had been designed using the pinned model. In Blanding's words: "a good conceptual model of the connection between the web and roller is to imagine that a single thumbtack has been used to secure the web to the roller surface at the approximate center of the contact area between the web and roller." Naturally, "the thumbtack would have to be repeatedly moved as the web advances." This is not as difficult as might be thought.

The torque transmission properties of a clamped connection were combined with the kinematic properties of a pinned connection by pinching the middle of the foil between a spherical roller bearing on a spring arm and the fixed index roller (Figure 4.22). A spherical ball bearing could have sufficed, but thermal concerns about cage material dictated that a spherical roller bearing be used instead. The self-aligning properties of the bearing facilitate alignment with the index roller's axis of rotation and pivoting with the web prior to equilibrium (Figure 4.2), thereby preventing web overconstraint. A picture of the final machine can be seen in Figure 4.24.

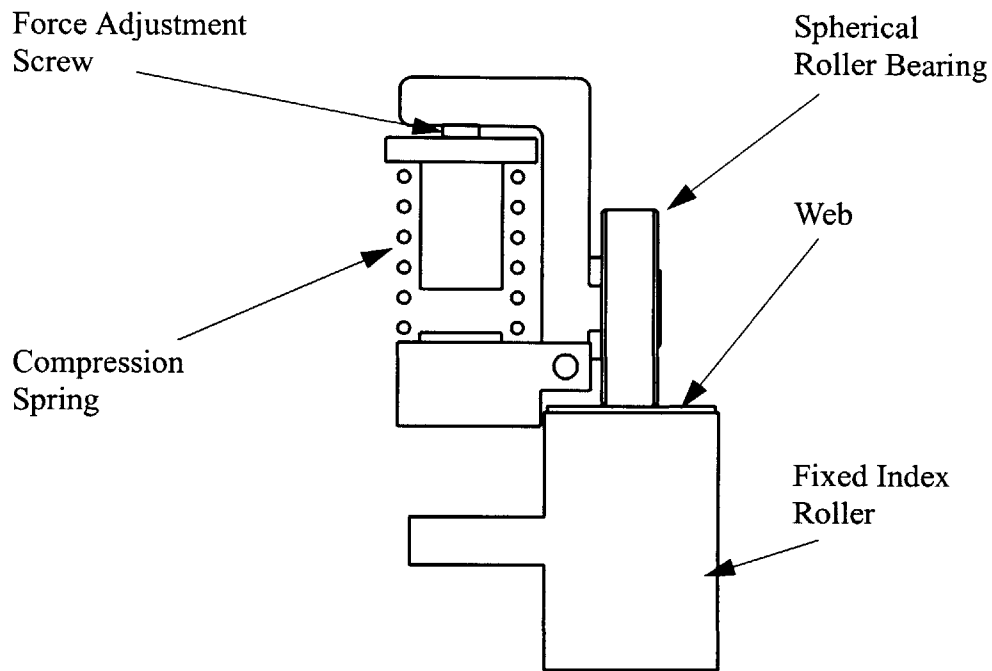

Figure 4.22 The spring mounted spherical roller bearing and the index roller

After debugging was completed and the pinch roller had been installed, a speed run was conducted to confirm that the machine's various novel elements could be used for continuously (in addition to discretely) moving webs. The web was run at speeds up to 19 cm/sec. Testing was not done at higher speeds because the DC motor on the take-up spool could not keep up with the web's rate of advance. The only anomaly encountered was a slow precession of the spring loaded pinch roller. As the web ran between it and the index roller, the pinch roller would periodically ride up on its edges. The rate of precession was proportional to web speed, so though it has never been observed, the behavior may be occurring during indexed operation. More likely, precession is prevented at low speeds by small scale sideslip between the web and pinch roller. Crowning the outer surface of the pinch roller might prevent precession, but could also result in underconstraint, i.e. what fixes the axis of rotation of a spherical bearing with a crowned outer race?

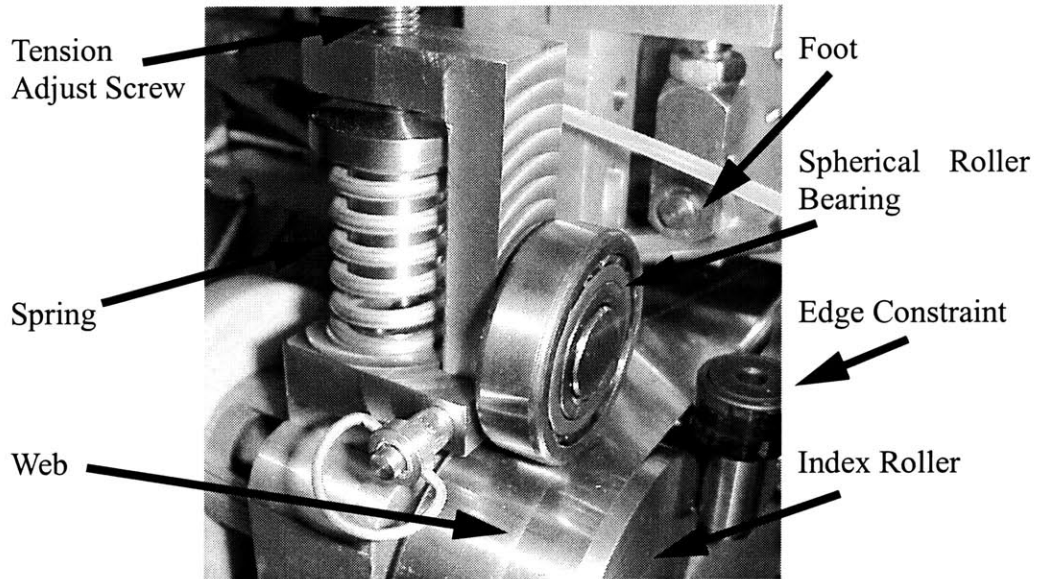

Figure 4.23 A picture of the pinch roller assembly

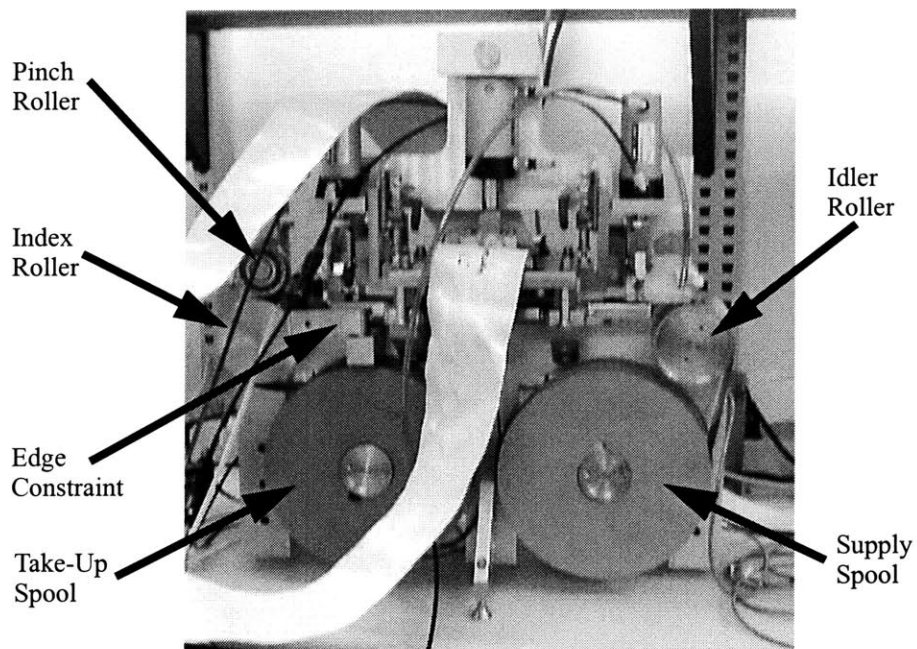

Figure 4.24 The final machine. The ribbon cables are used to test the contactors.

To test the system's sensitivity to the coupling's accommodation of parallel and axial misalignment, the machine was designed to fit two different kinds of couplings. Helical Products' HCR 100-12-12 could be used as well as a custom coupling designed for increased axial and parallel stiffness. The lower stiffness of the standard HCR coupling made for more shaking of the spools, but the machine functioned with both kinds of coupling installed, leading to the conclusion that the parasitic axial and parallel deflections are of little consequence.

4.9 Conclusions

Although the idler is underconstrained, the system works very well, so web tension may have some ability to contain underconstraint by favoring the shortest path between the sources of tension. If the first and second BLPs had not also functioned, it would be tempting to attribute some importance to the restoring force of the flexible couplings, but taking all the data into account, this seems unlikely.

The use of beam type flexible couplings and universal joints at zero caster radius to create gimbaling and castering axes is believed to be a major innovation. The fabrication and mounting of spools whose diameter is on the order of the width of the web being supported has been greatly simplified. Specialized axially compliant rollers are no longer necessary. The necessary properties can be created using readily available machine elements and parts simple enough to be machined from whole cloth. The use of a spherical bearing as a pinch roller is likely just as important. Because the web can be pinched without overconstraint, systems that would otherwise need to be highly tensioned may now be run more forgivingly. Finally, it has been demonstrated that the principals of kinematic web handling can be used to design a working machine.

Chapter 5

PLUNGING MODULE

5.1 Module Requirements

The design of the plunging module was driven by the number of pins it was required to hold, fifty, and the minimum pitch of those pins, 0.010". The machine tests fifty pins at a time as that was a large enough number to produce meaningful data quickly, and not so large as to require a prohibitively large amount of space inside the environmental chamber. Coincidentally, it is within the range of the number of pins that a typical contactor might contain. A pitch of 0.010" was chosen because it is the largest pitch for which pins are commonly available. Smaller pins can always be mounted at a pitch larger than their minimum.

The stroke of the plunge module is approximately equal to the longest stroke available for the largest size spring pin, 0.5 in. The data produced on the machine will be used to design contactor systems for handlers, so the machine was designed to equal or better the planarity provided by such systems, 0.001 inch per inch. As spring probes are specifically designed for poor planarity applications, it was not expected that poor tester planarity would substantially affect the outcome. Finally, it was also necessary that the plunging module fit inside the environmental chamber along with the web handling module and that it operate over a temperature range of -50° to 150° C.

5.2 Spring Pin Arrangement

To optimize foil use while preserving the simplicity of the indexing system, the pins were mounted 0.025" apart in the direction normal to the motion of the foil (the crosstrack direction). Since the foil is advanced in 0.025" increments, doing so allots each spring pin its own 0.025" by 0.025" square of virgin material for each plunge. To reconcile the crosstrack spacing of 0.025" with the minimum pitch requirement of 0.10," the pins were mounted on a diagonal (Figure 5.1). This diagonal determines the width of the foil, 1.5" ($0.025" \times 50 + 2 \times 0.125"$ margins).

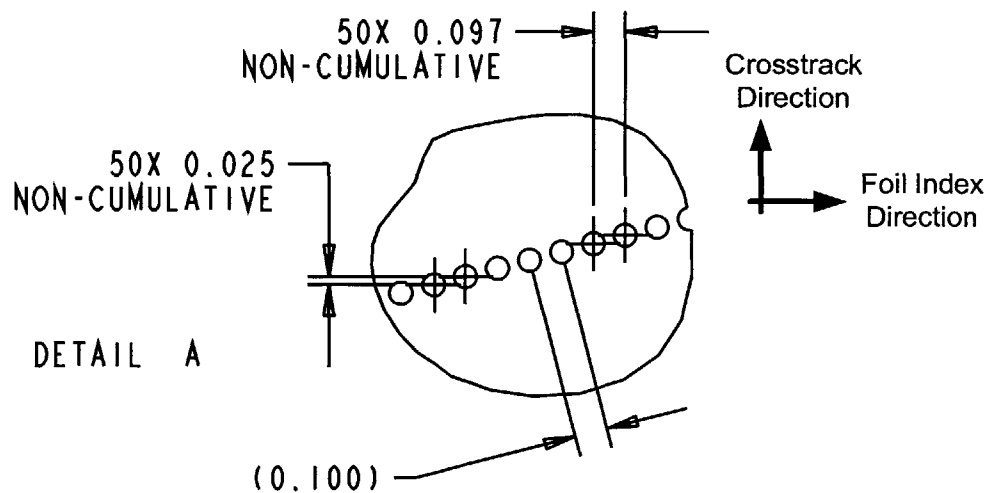

Figure 5.1 Spring Pin arrangement to optimize foil utilization while maintaining index system simplicity

5.3 Bearings and Actuation

The stroke length of 0.5 inch and the requirement that the system operate over a wide temperature range made flexures an obvious bearing option. Linear rails like those from STAR Linear or Thompson are rated to only 100° C, and provide more travel than necessary. A linear bearing could have been built from components such as the Graphalloy bearings used elsewhere in the machine, but there was no need. As part of a recently can-

celled project, a set of flexures optimized for linear travel over a 0.5 inch stroke had been designed and fabricated (Figure 5.2). The flexures had even been designed for the same temperature range. As seen in Figure 5.3, with one end of the flexure attached to the contactor assembly and one end fixed to the machine frame, the contactor is plunged by a pneumatic piston.

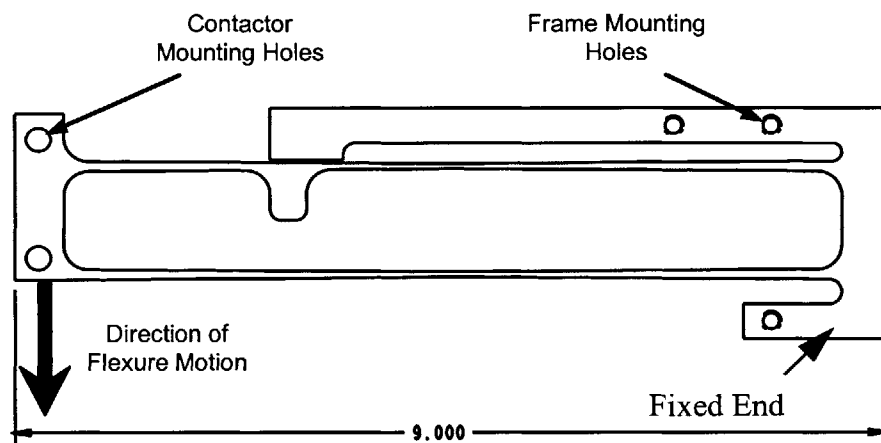

Figure 5.2 Flexure designed for linear motion for 1/2 inch stroke over a broad temperature range

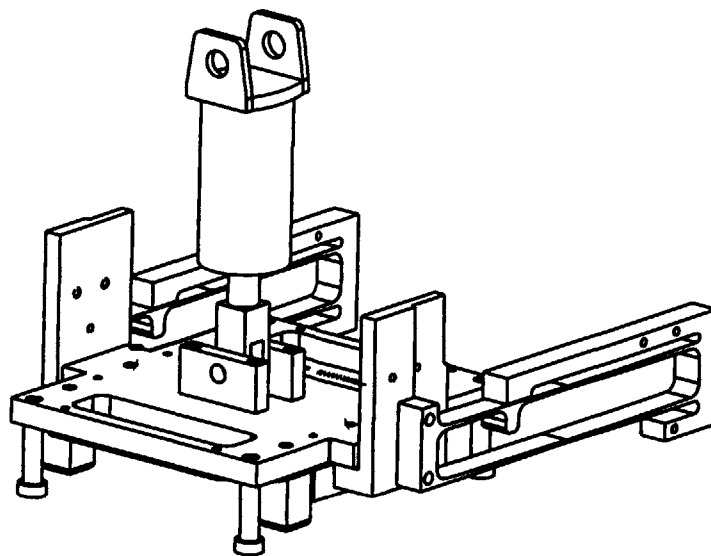

Figure 5.3 Contactor sub-assembly with flexures and piston attached

A pneumatic piston was selected for actuation. A single kind of piston could not serve for the full temperature range, but the modular nature of the actuator allows for rapid change-out between high and low temperature models. A system based on an electric actuator could have been designed and would have had certain advantages, i.e. explicit control of plunge rate and software configured plunge depth, but no off the shelf alternatives were available. As a compromise between the two, it was decided to allocate space inside the environmental chamber and controller resources for a future upgrade to electric actuation. The mounts for the pneumatic piston were fabricated as attachments to the frame and the contactor assembly to facilitate the same upgrade.

The stop inside a pneumatic piston is not a reference surface, so hard stops were mounted on the contactor to halt the plunge at the appropriate distance from the plate supporting the foil (Figure 5.4). Because each kind of spring pin has a different stroke and uncompressed

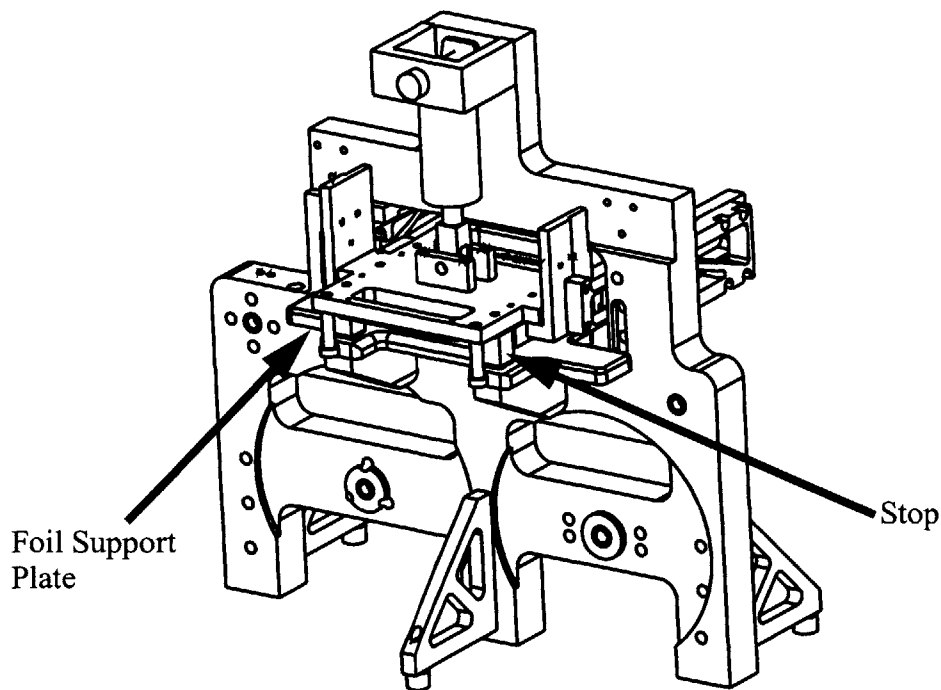

Figure 5.4 The plunge sub-system attached to the machine frame

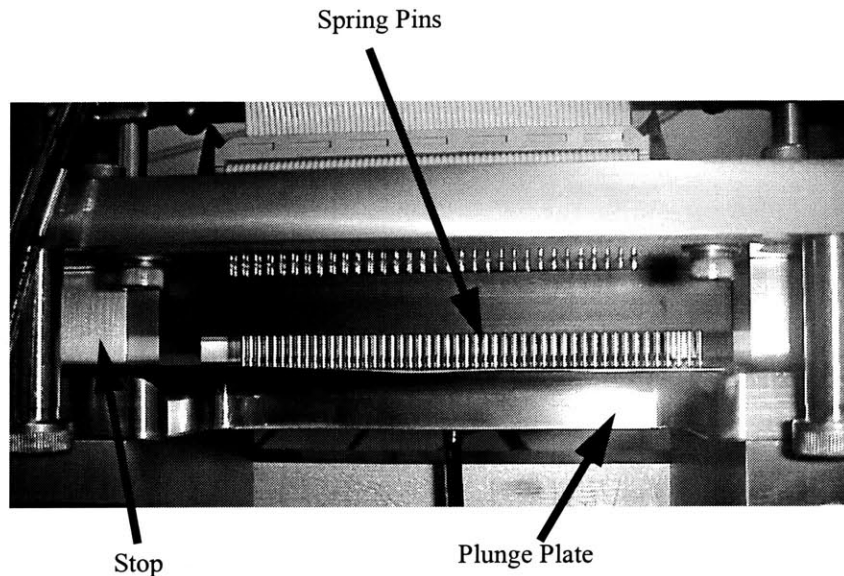

Figure 5.5 A picture of the contactor assembly showing the stops and the spring pins

height, different stops are required for each type of pin to be tested. A set of stops sized to the un-plunged height of the contactor was used to align the flexure displacement axis to the plunge plate supporting the foil. To do an alignment, the plunge module is assembled and loosely attached to the machine with screws. While holding the contactor hard against the plunge plate supporting the foil, the screws fixing the plunge module to the frame are tightened, aligning the plunge module to the frame. After an alignment has been performed, a two dimensional pin and groove kinematic coupling is employed to repeatedly fixture the contactor plate to the plunge module.

5.4 Preventing Foil Motion

During real testing, the DUT does not move. It is unknown, what effect dragging a probe across a contact pad would have on both the pad and the probe, but it is assumed it would not be good. Comparisons to fingernails being dragged across a chalk board are appropriate. To preserve test integrity, such a condition must be prevented in the test machine. The software in the controller goes a long way in this regard, but for redundancy, a pair of “feet” were added on either side of the contactor. Prior to each contactor plunge, the pneu-

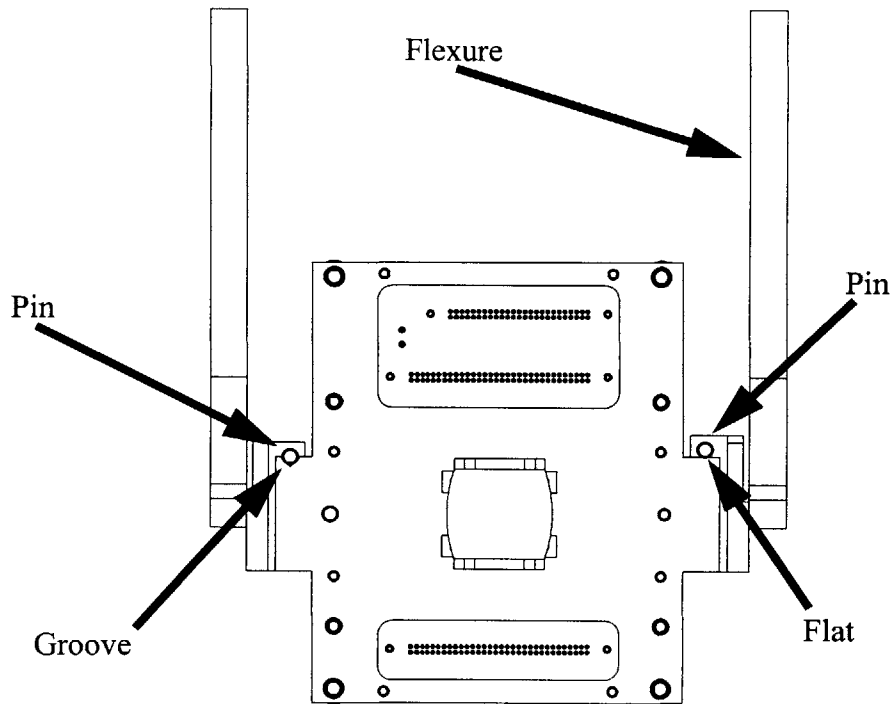

Figure 5.6 Top view of plunging module (with the actuating piston removed) showing the two dimensional kinematic coupling used to align the contactor plate with the plunging module

matic pistons the feet are mounted on are driven down, trapping the foil between the feet and the plunge plate. After checking a sensor to confirm the feet are extended, the controller cycles the contactor. After the contactor has been withdrawn, the feet are raised, the foil is indexed, and the process is repeated.

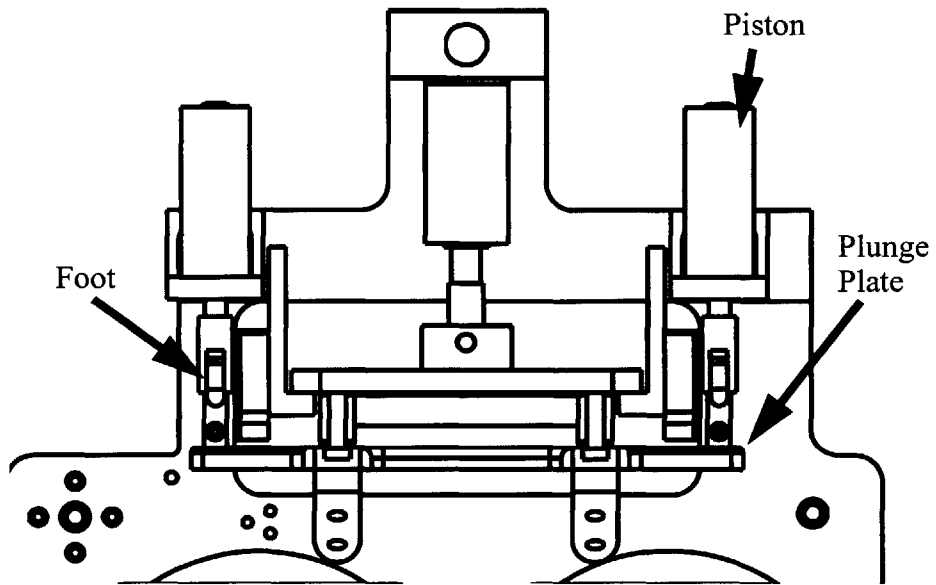

Figure 5.7 Front View of plunge sub-system - note the feet

Chapter 6

CURRENT SOURCING AND IN-SITU RESISTANCE TESTING

6.1 Current Sourcing

The tester was designed with the assumption that C_{res} could be greatly influenced by the amount of current sourced through each probe (see Chapter 1). In anticipation of this predicted coupling, a contractor was commissioned to build an array of current sources to independently drive 200 mA through each probe. If the voltage across the whole probe array had been regulated instead, more current would have flowed through the lower resistance probes. For example, if 36 pins in a 48 pin contactor have a resistance of $2\ \Omega$ and the other 12 pins have a resistance of $0.25\ \Omega$, eight times as much current will flow through the lower resistance pins. Resistance differences of that order are reasonable, both because probes can continue to function with resistances that high and because it might be desirable to simultaneously run different cleaning protocols on the same contactor. Since current affects change in C_{res} , sourcing current in parallel would have created a feedback loop that would work to make the resistance of each probe equal to that of every other probe.

6.2 In-Situ Resistance Testing

Realistically reproducing spring probe operating conditions serves no purpose if the condition of the probes cannot be monitored. To that end, the tester is equipped with a CIR-RIS tester for in-situ four-wire resistance measurement of each of the fifty spring probes. The two connections to each probe's receptacle are accomplished by soldering the recepta-

cles to a circuit board, but the other two connections are somewhat more circuitous. The return path for the current used in the four-wire test and the second voltage probe connection are both made via the tester frame (Figure 6.1). Naturally, the resistance of this path was a concern.

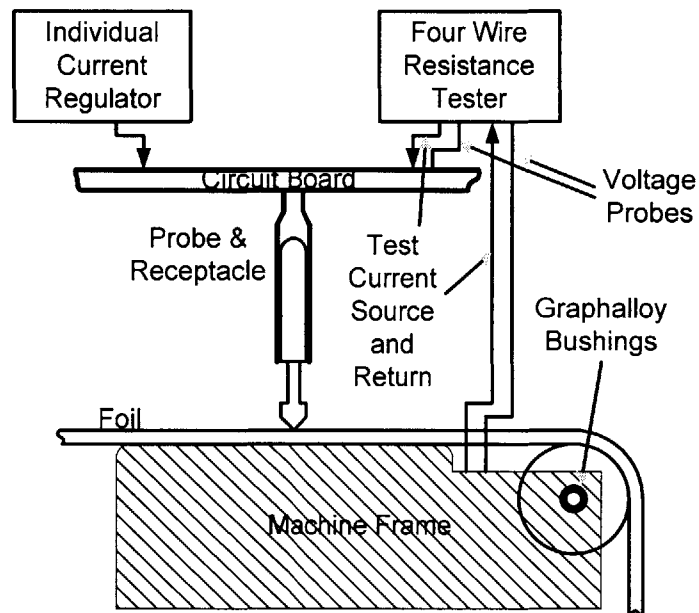

Figure 6.1 Resistance test schematic. Note that conduction path includes the frame and bushings.

6.2.1 Worst Case

The worst case resistance for making these connections through the tester frame is if the current all travels through only one of the Graphalloy bushing sets supporting the web handling sub-system. It would not have been advisable to transmit current through a ball (or other rolling element) bearing because of the tendency to arc. But Graphalloy™ (an alloy of graphite and various metals) bushings had already been selected for their superior performance at temperature extremes, and bushings do not arc. Furthermore, another Graphalloy application is as a motor brush material. Low resistance materials are favored for brushes because any resistance in the brush leads to a direct decrease in motor perfor-

mance. To test the Graphalloy's resistance under working conditions, the bench level prototype seen in cross section in Figure 6.3 and pictured in Figure 6.2 was built.

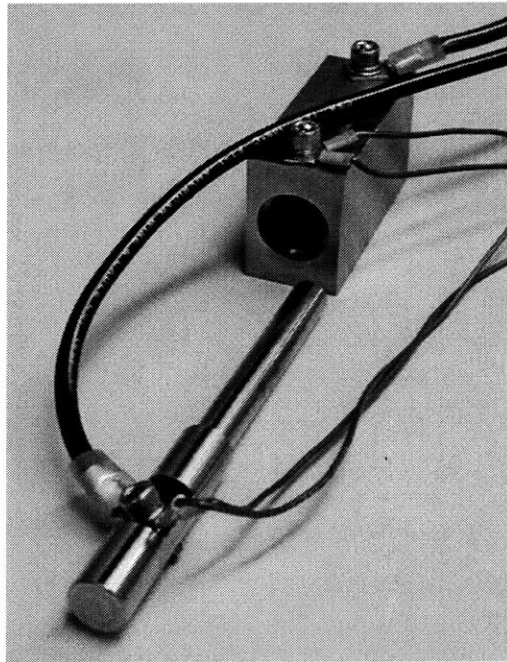

Figure 6.2 Picture of Graphalloy resistance test bench level prototype. Note the heavy gage wire for current sourcing and the smaller gage wire for four wire resistance measurement.

6.2.2 BLP Results

The resistance of BLP was measured (four wire method) at ambient conditions, at 150° C, and after 30 amps had been passed through it. The BLP revealed (and later use of the tester confirmed) that the line contact inside the bushing had a negligibly small resistance of only a few milliohms. The resistance rose with temperature, but never exceeded our self-imposed 25 milliohm limit, and once the temperature stabilized, it fell back to the ambient level. The resistance increase may have been caused by thermal resistance, but it is not certain. Because the limit was never exceeded and because a thermal soak was necessary to prepare the foil, the resistance variation was acceptable.

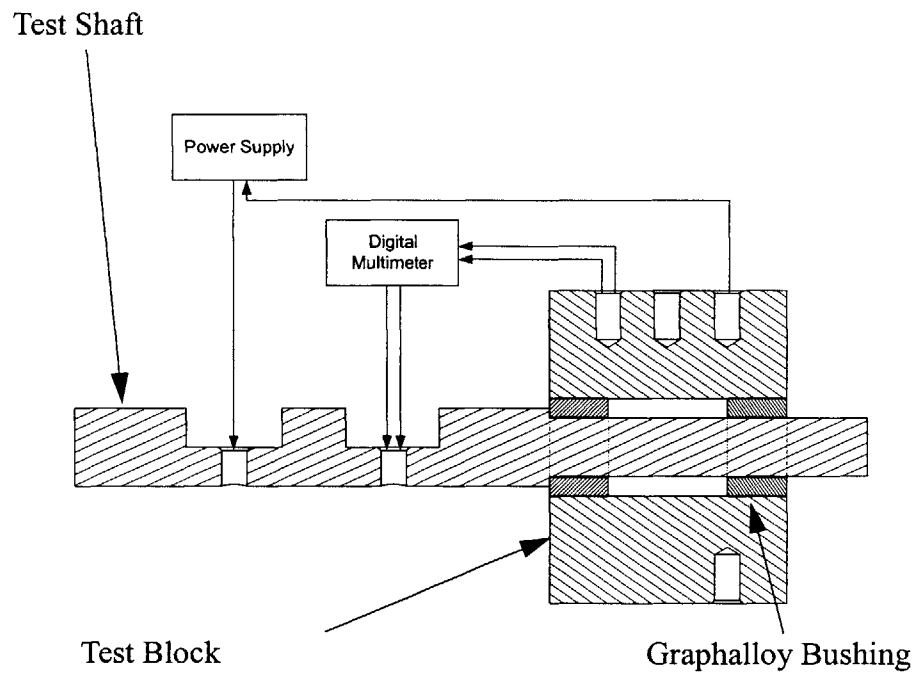

Figure 6.3 Cross-section of bench level prototype for testing Graphalloy resistance. The BLP was connected to a power supply to simulate the effects of the current source array driving current through the contactor. The digital multimeter tested the resistance of the assembly using the four-wire method.

Chapter 7

CONTROLLER SPECIFICATION

The following information was provided to the outside contractor charged with constructing the testing machine control system.

7.1 System Components

	Function	Input/Output	Interface
Current Sourcing Module (CSM)	Sources a regulated current through the contactor	Trigger	TTL Active High
CIRRIS Tester	Measures Contactor C_{res}	Trigger, End of Test	Consult CIRRIS Manual
Take-Up Motor	Tensions Foil	Current Set by Operator	DC current
Stepper Motor	Indexes Foil	Pulse to Step	5-24 VDC
Pneumatic Sub-System	Plunging Module and Actuator Cooling	See Pneumatic Sub-System Schematic	See Pneumatic Sub-System Schematic
Thermocouples	Measure temperatures of Environmental Chamber and Actuator	K-type	
Rotation Sensor	Detect Idler Roller Rotation		
Foil Sensor	Detect end of foil		
Expansion Servo	Resources on controller for future servo		

7.2 System Schematic

The schematic in Figure 7.1 was also furnished to the controls contractor. The contractor was responsible for furnishing the components inside the dashed box. The contractor selected to use fiber optic sensors for the rotation and end of foil sensors. The end of foil sensor was mounted in the stainless steel plate supporting the foil during plunging. The rotation sensor was mounted as described in Appendix B.

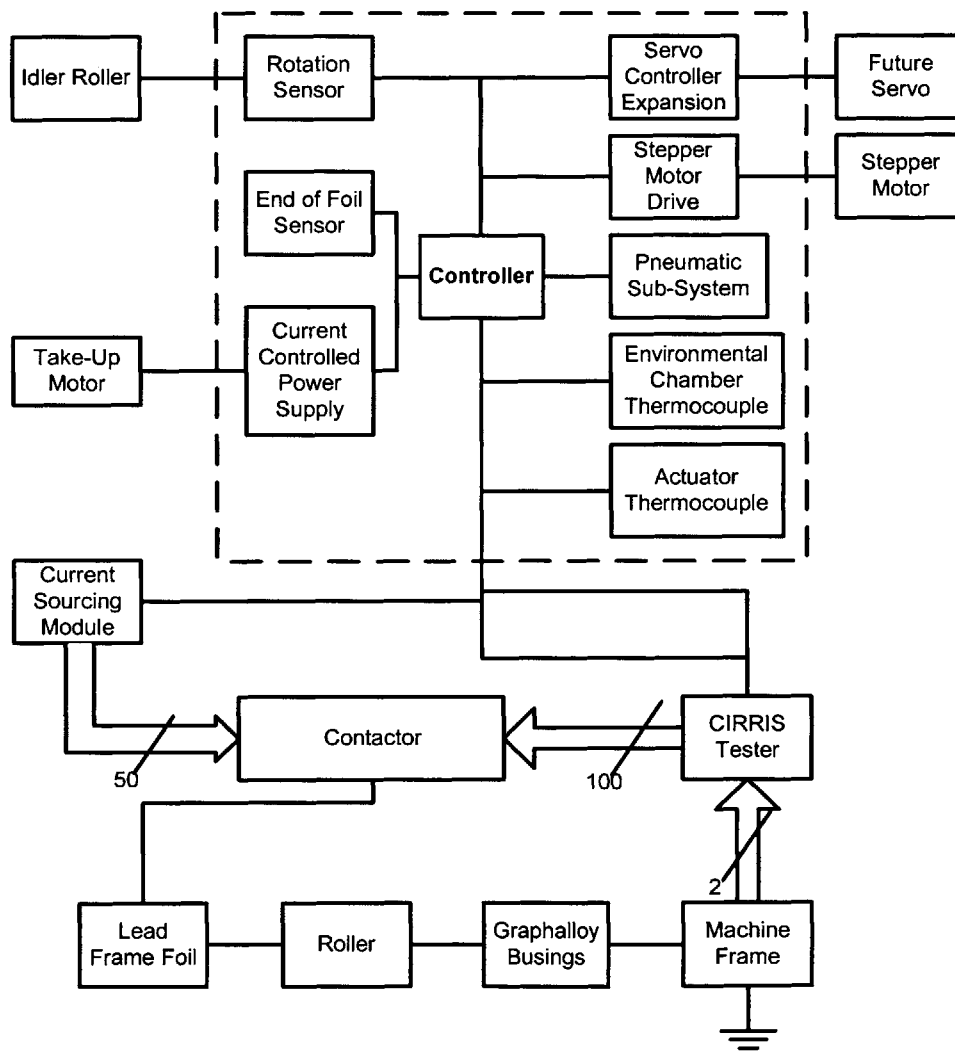

Figure 7.1 System Schematic, the contractor was responsible for the components inside the dashed box.

7.3 Pneumatic Schematic

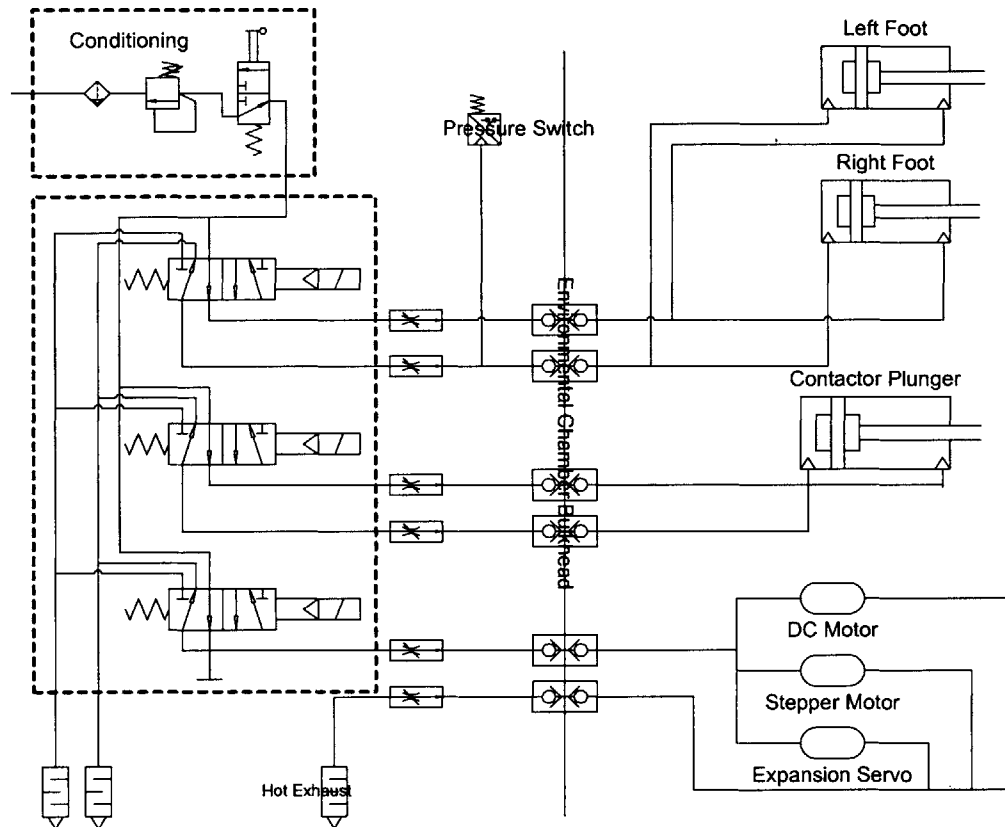

Figure 7.2 System Pneumatic Schematic. Valve assembly, regulator, etc. supplied by contractor. Actuators already installed on machine

7.4 Operator Interface

7.4.1 Actions

- Manual Foil Advance
- Manual Plunge
- Manual Cooling Air on/off
- Test Start
- Test Pause

7.4.2 Inputs

TABLE 7.1 Inputs

	Description	Typical Value(s)	Unit
Soak Time	Delay before first stepper index operation. Foil must be thermally soaked	30	minutes
Source Time	Time current is sourced through contactor by CSM	3	seconds
Cycle Time	Total index to index time, not including C_{res} test by CIRRIIS	1	second
Temperature Set Point	Environmental Chamber Set Point, alarm if out of range	-50,20,150	°C
Temperature Window	Allowable Deviation from set point	1,2,5,10	°C
Cycles in Test	Number of cycles to run before test completion	10,000	cycles
C_{res} Testing Interval	Number of cycles between C_{res} tests by CIRRIIS	10	cycles
Operator E-mail Address	Send operator E-mail when errors encountered	string	N/A

7.5 Sequences

7.5.1 Startup

1. Operator enters test parameters
2. Operator initiates test
3. Turn on Stepper
4. Turn on Take-up Motor
5. Start Cooling Air ($7^{\circ} \text{C} \leq \text{Temperature Set Point} \leq 30^{\circ} \text{C}$)
6. Open Cooling Valve
7. Wait for **Soak Time**

8. Begin Test Sequence

7.5.2 Test Sequence

1. Sensors
 - Check Foil Sensor
 - Compare Thermocouple to **Temperature Set Point & Temperature Window**
2. Index Foil
 - Check pressure switch
 - Pulse stepper motor
 - Check for rotation
3. Lower Feet
 - Actuate Feet Piston Valve
 - Check pressure switch
4. Plunge Contactor
 - Check pressure switch
 - Actuate Plunge Piston Valve
5. Source Current
 - Trigger Switching Array
 - Trigger Current Sourcing Module
 - Wait **Source Time**
 - Release Current Sourcing Module
6. Test Resistance
 - Check cycle count (multiple of C_{res} **Testing Interval?**)
 - Trigger CIRRS
 - Wait for End of Test signal
7. Raise Contactor
 - Actuate Plunge Piston Valve
8. Raise Feet
 - Actuate Feet Piston Valve
 - Check Pressure Switch
9. End Cycle
 - Wait out the rest of **cycle time**

7.6 Data Logging and Operator Alert

When the controller detects an error, it should send E-mail to the address supplied by the operator stating the nature of the error and the time it occurred. This will facilitate unattended operation of the machine.

Each time the contact resistance of the fifty sites in the contactor is tested, the controller should record cycle number, the chamber temperature, actuator temperature, and time. At the head of the file all the test variables should be recorded.

Chapter 8

TEST RESULTS

More than one hundred thousand contactor hits have been made by this point. The witness marks left on the 90/10 Sn/Pb clad Alloy 42 are the subject of the photos in Figure 8.1 and Figure 8.2.

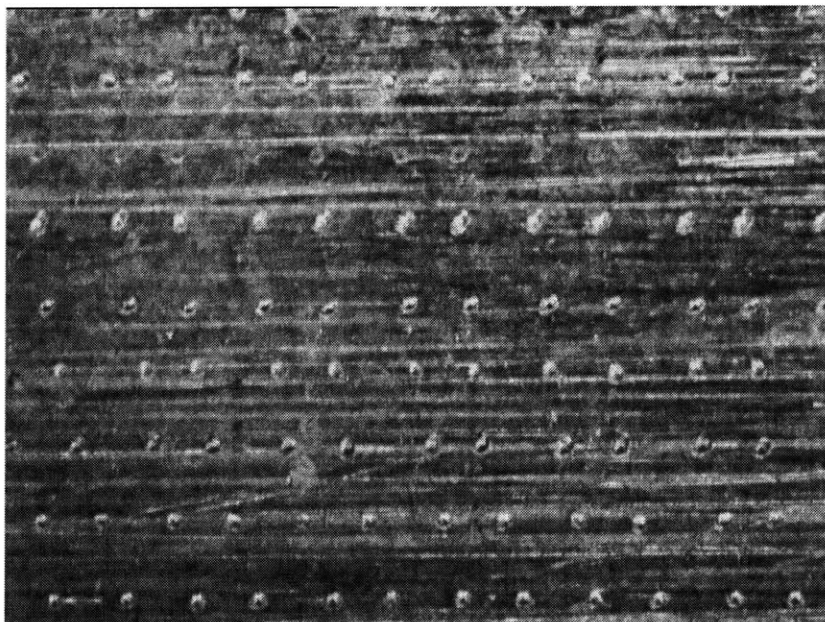

Figure 8.1 Wide field view of the witness marks left by the array of spring pins on the 90/10 Sn/Pb clad Alloy 42 foil (37.5 X magnification)

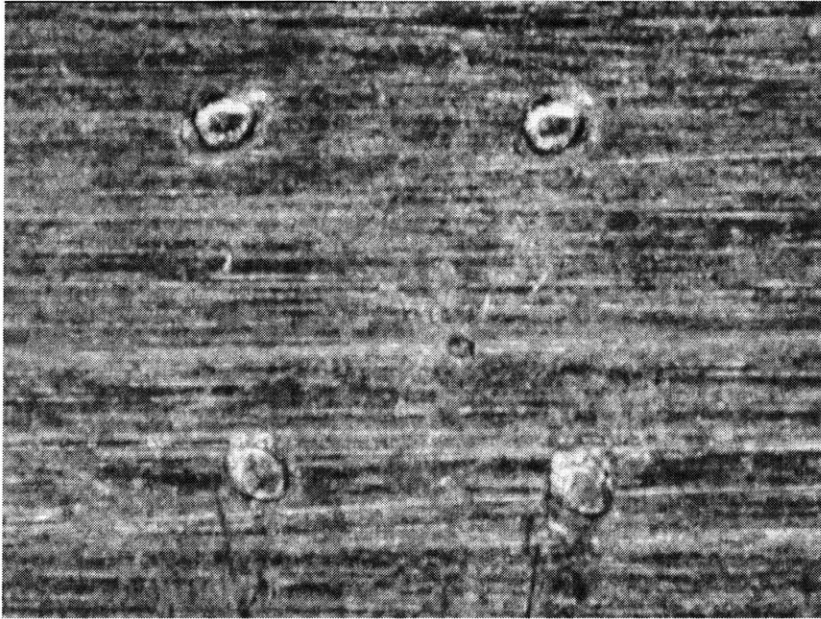

Figure 8.2 Tight field view of the witness marks (203 X magnification)

An electrical interaction between the CIRRIS tester and the rest of the system has only just been resolved, so contact resistance data is now becoming available. To resolve the problem, the machine is electrically disconnected from everything except the CIRRIS during resistance testing. There is not yet enough data to support conclusive findings, but some preliminary observations can be made.

To create the first plot in Figure 8.3, the current sourcing array was set to drive the five ten pin zones of the contactor at 0, 100, 200, 300, and 400 mA respectively. The controller was programmed to measure resistance every 10 hits. No cleaning was done throughout the experiment. The data from each set of ten pins was averaged into one curve, and a 149 point moving average was used to smooth the curve. For the second plot, the standard deviation was computed for each group of ten pins at each measurement cycle. The third plot represents the results of fitting a linear polynomial to the data from each current group.

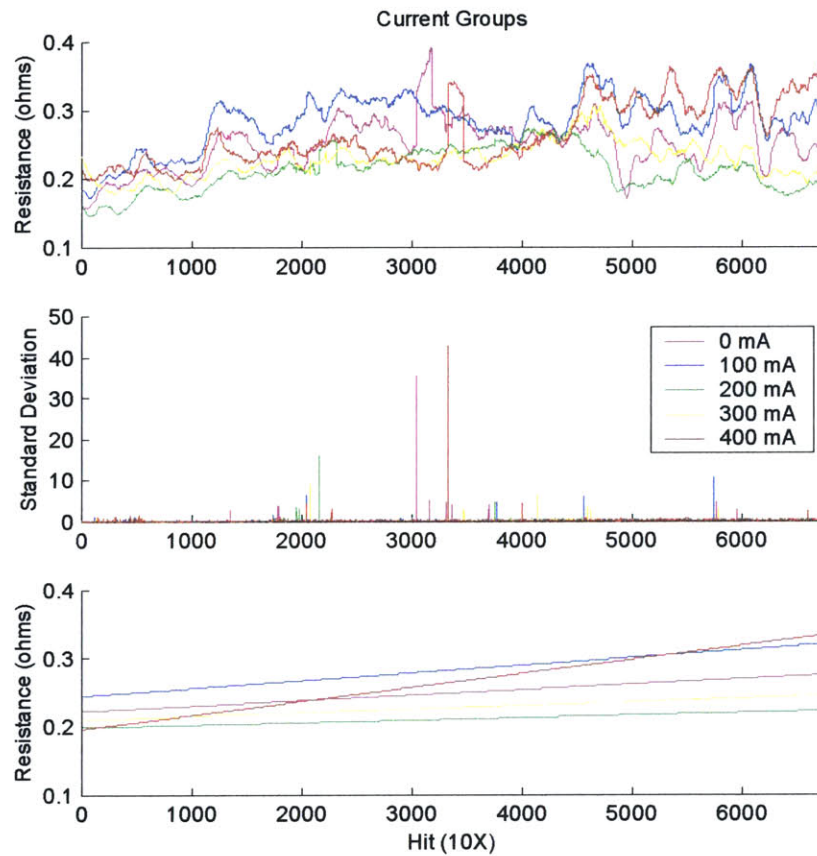

Figure 8.3 A plot of contact resistance vs. number of hits for several different current settings

As expected, the resistance of the pins increases with use. The increase can be most clearly seen in the plot of linear regression lines. The trend is slow, but distinctly upward. Some of the more abrupt peaks in the resistance curves are probably the result of single pin's poor contact. The spikes in the standard deviation plot support this conjecture, but more experimentation will be necessary before a specific cause can be assigned. A troubling aspect of the plot is that the resistance curves tend to move together. At approximately 11,000 hits, at 45,000 hits, and again at 57,000 hits, the contact resistances from several different current groups all increase. These abrupt changes do not coincide with a standard deviation spike. It is unknown what mechanism drives this system-wide phenomenon.

As hinted at in Figure 8.3 and borne out in Figure 8.4, the data does not support a link between increased current and increased resistance. To construct the plot in Figure 8.4, the mean of the resistance measurements for each pin over the whole data series was plotted against the current sourced through the pin. Each square is the average of those averages for a particular current group. Surprisingly, the series with the two highest resistances are the 400 mA series and the 100 mA series. There are several possible explanations. The effect of current on resistance may manifest itself very slowly, and 70k hits is simply not enough data to break out of the noise. Alternatively, the effect of increasing current may be negligible at the levels being studied. Further experimentation is necessary.

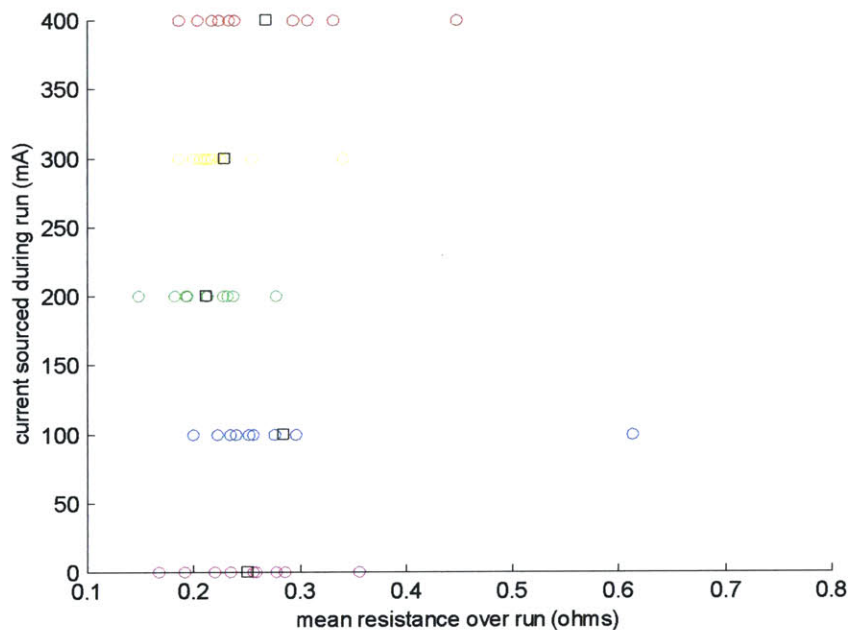

Figure 8.4 The mean of each pin's resistance measurements is plotted against the amount of current sourced through the pin. The squares represent the average of those averages for each current group.

The nature of the troubling outlying points in Figure 8.4 can be seen in Figure 8.5. There, the data for each of the pins in the 100 mA group has been plotted. The only processing was the same moving average smoothing used in the previous plots. For unknown reasons,

the contact resistance of pin 19 is consistently much greater than the resistance of its peers. An examination of the pin will be made, but it was expected that pin degradation would be a gaussian process, so pin 19 may be a completely legitimate outlier.

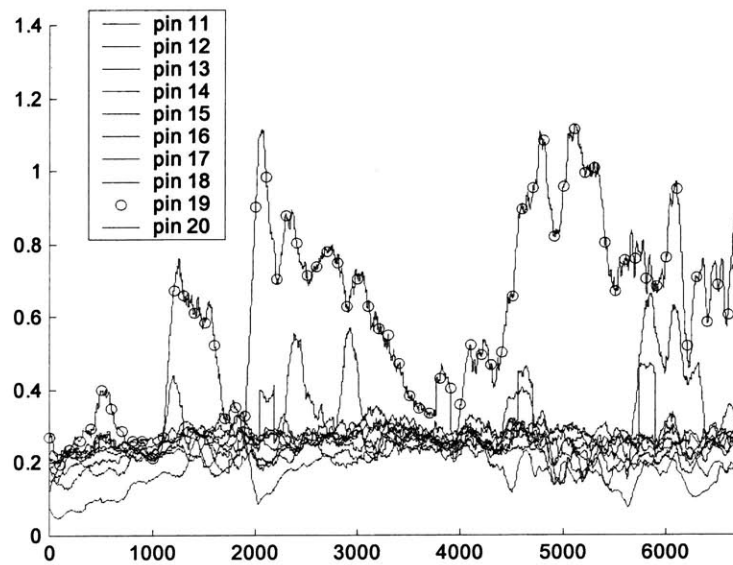

Figure 8.5 Plots of the resistance data for all ten pins in the 100 mA group. For unknown reasons, the contact resistance of pin 19 is consistently higher than that of the other pins.

Chapter 9

CONCLUSIONS

9.1 Future Improvements

Weight. For high and low temperature testing, the tester must be placed inside an environmental chamber. It is too confined inside the environmental chamber to service the tester. The machine must therefore be removed from the chamber for service. It should be light enough that one person can place it inside the environmental chamber. This is not presently the case.

Size. The tester was sized and packaged for the environmental chamber within which it was to be used. Such chambers come in a variety of different sizes and configurations. If additional testers are to be built, a survey should first be made of the chambers available on the market to ensure the tester is being designed to fit within as many of them as is reasonable.

Non-Rotating Pistons. The feet that hold the foil during the contactor plunge cycle are attached to normal (rotating) pistons. Rotation is prevented in that it is not encouraged and by a not particularly robust guidance system. Non-rotating pistons are available in the appropriate size, but the lead time is considerable. To improve system robustness, they should be ordered and installed.

Material changes. Many parts of the machine are made from type 304 stainless steel. This was done to facilitate ease of re-work, because stainless steel resists corrosion natively, while aluminum parts must be re-anodized after re-work. Many parts could be fabricated from aluminum without impacting performance, considerably reducing cost and weight.

Spool Loading. As the spool cores are now designed, it is more difficult than necessary to load and unload the foil spools. The cores should be re-designed so that the spools and cores can be detached from their flexible couplings without first removing the spool. A shoulder should also be added to the spools outer surface to provide a reference edge for mounting the spools.

Slip Clutch. For debugging purposes, the slip clutch was designed to be adjustable. An optimum torque setting should be determined, and future incarnations of the slip clutch should not be adjustable.

Refinement of the Edge Constraint. There exists a failure mode where the foil will slip beneath the cam followers of the edge constraint. The problem can almost certainly be fixed by lowering the cam followers. During the design, it was anticipated that the foil slipping *over* the cam followers would be more of a problem. The edge constraint was therefore designed such that the foil struck nearer the bottom than the top of the cam followers. If centering the foil on the edge constraint does not resolve the problem, the cylindrical profile of the cam followers could be altered to a shape contrived to drive the foil towards the center.

Dirty foil. As delivered by the cladding house, the foil is not clean. Dirt on the foil can cause spurious contact resistance measurements. Since contacting is nominally done in a clean environment, the dirt also makes for unrepresentative testing. A cleaning module should be incorporated on the machine. It could be as simple as a jet of air or a set of brushes. Or, preferably, the foil manufacturer should be instructed to clean the foil prior to shipment.

More Contactors. The contactor plunging mechanism and the configuration of the test head are too refined for testing spring pins. If other types of contactors are to be tested, they will need to be redesigned. For the time being, only spring pin testing is possible.

9.2 Additional Applications

As mentioned in the title of this thesis, the tester was designed “with Specific Application to Semiconductor Testing.” Other uses are quite imaginable. Generally, tribological testing requiring virgin material is done on a rotating disk employing a record player like mechanism. As mentioned in Chapter 3, such systems have a rather small amount of surface area. Using a machine more similar to the tester described here would make such testing much easier

9.3 Conclusions

The most technologically interesting aspect of the machine (as opposed to the data it will generate) is the manner in which the web handling is done. The use of beam type flexible couplings at zero caster radius to create gimballing and casting axes is believed to be a major innovation. The fabrication and mounting of spools whose diameter is on the order of the width of the web being supported has been greatly simplified. Specialized axially compliant rollers are no longer necessary. The necessary properties can be created using readily available machine elements and parts simple enough to be machined from whole cloth. The use of a spherical bearing as a pinch roller is likely just as important. Because the web can be pinched without overconstraint, systems that would otherwise need to be highly tensioned may now be run more forgivingly. Finally, it has been demonstrated that the principals of kinematic web handling can be used to design a working machine.

4

REFERENCES

- [Bauccio, 1993]* Bauccio, Michael and American Society for Metals eds. ASM Metals Reference Book. 3rd. ed. Materials Park, Ohio: ASM International, 1993.
- [Blanding, 1999]* Blanding, Douglas K. Exact Constraint: Machine Design Using Kinematic Principles. New York, New York, 1999
- [Buch, 1999]* Buch, Alfred. Pure Metals Properties: A Scientific-Technical Handbook. Materials Park, Ohio: ASM International, 1999
- [Helical Products Company, Inc., 1992]* Helical Products Company, Inc., The Helical Coupling Catalog. Santa Maria, CA: Privately printed, 1992.
- [Mills, 1995]* Mills, Anthony F., Basic Heat and Mass Transfer. Chicago, IL: Irwin, 1995.
- [QA Technology Company, Inc., 2000]* QA Technology Company, Inc. Product Catalog. Hampton, NH: Privately printed, 2000.
- [Shackelford, 2000]* Shackelford, James F., and William Alexander eds. CRC Materials Science and Engineering Handbook. 3rd. ed. Boca Raton, FL: CRC Press, 2000.
- [Shigley, 1989]* Shigley, Joseph E., and Charles R. Mischke. Mechanical Engineering Design. 5th. ed. New York, NY: McGraw-Hill Inc., 1989.

Appendix A

THERMAL MODEL RESULTS

Vertical Wall											
Length (m)	0.12		Ambient Temp (K)				293				
Air Temperature	Prandtl	kinematic mu (m ² /s)	Delta T (K)	k (W/mK)	Rayleigh	Psi	Nusselt	h _c (W/m ² K)	Required Length		
223K	-50°C	0.722	8.663E-06	35K	2.1E-02	8.4E+12	Invalid	0.350	9.45E+02	2.380	0.578 m
248K	-25°C	0.714	1.059E-05	22.5K	2.3E-02	3.0E+06	Valid	0.348	8.94E+01	17.016	8.081 m
273K	0°C	0.707	1.264E-05	10K	2.5E-02	2.7E+06	Valid	0.346	8.89E+01	18.407	7.470 m
298K	25°C	0.701	1.482E-05	2.5K	2.7E-02	4.5E+05	Valid	0.345	8.13E+01	18.190	7.559 m
323K	50°C	0.695	1.712E-05	15K	2.9E-02	1.9E+06	Valid	0.344	8.70E+01	20.899	6.579 m
348K	75°C	0.690	1.955E-05	27.5K	3.1E-02	2.4E+06	Valid	0.343	8.82E+01	22.671	6.065 m
373K	100°C	0.686	2.210E-05	40K	3.3E-02	2.6E+06	Valid	0.342	8.85E+01	24.212	5.679 m
398K	125°C	0.682	2.478E-05	52.5K	3.5E-02	2.5E+06	Valid	0.341	8.83E+01	25.644	5.362 m
423K	150°C	0.680	2.758E-05	65K	3.7E-02	2.4E+05	Valid	0.340	7.94E+01	24.361	5.644 m

Top Surface (when working above ambient)											
Length (m)	0.0381		Ambient Temp (K)				293				
Air Temperature	Prandtl	kinematic mu (m ² /s)	Delta T (K)	k (W/mK)	Rayleigh	Nusselt	h _c (W/m ² K)	Required Length			
223K	-50°C	0.722	8.663E-06	70K	2.1E-02	1.6E+06	Valid	1.43E+01	7.847	17.5 cm	
248K	-25°C	0.714	1.059E-05	45K	2.3E-02	6.3E+05	Valid	1.18E+01	7.096	19.4 cm	
273K	0°C	0.707	1.264E-05	20K	2.5E-02	1.8E+05	Valid	9.18E+00	5.985	23.0 cm	
298K	25°C	0.701	1.482E-05	5K	2.7E-02	2.9E+04	Invalid	6.40E+00	4.511	30.5 cm	
323K	50°C	0.695	1.712E-05	30K	2.9E-02	1.2E+05	Valid	8.50E+00	6.431	21.4 cm	
348K	75°C	0.690	1.955E-05	55K	3.1E-02	1.5E+05	Valid	8.95E+00	7.244	19.0 cm	
373K	100°C	0.686	2.210E-05	80K	3.3E-02	1.6E+05	Valid	9.05E+00	7.797	17.6 cm	
398K	125°C	0.682	2.478E-05	105K	3.5E-02	1.6E+05	Valid	9.00E+00	8.228	16.7 cm	
423K	150°C	0.680	2.758E-05	130K	3.7E-02	1.5E+05	Valid	8.88E+00	8.587	16.0 cm	

Bottom Surface (when working above ambient)										
Length	0.0381		Ambient Temp (K)				293			
Air Temperature	Prandtl	kinematic mu (m ² /s)	Delta T (K)	k (W/mK)	Rayleigh	Valid	Nusselt	h _c (W/m ² K)	Required Length	
223K	-50°C	0.722	8.663E-06	70K	2.1E-02	1.6E+06	Valid	1.9E+01	10.568	13.0 cm
248K	-25°C	0.714	1.059E-05	45K	2.3E-02	6.3E+05	Valid	1.5E+01	9.109	15.1 cm
273K	0°C	0.707	1.264E-05	20K	2.5E-02	1.8E+05	Valid	1.1E+01	7.209	19.1 cm
298K	25°C	0.701	1.482E-05	5K	2.7E-02	2.9E+04	Invalid	7.0E+00	4.966	27.7 cm
323K	50°C	0.695	1.712E-05	30K	2.9E-02	1.2E+05	Valid	1.0E+01	7.599	18.1 cm
348K	75°C	0.690	1.955E-05	55K	3.1E-02	1.5E+05	Valid	1.1E+01	8.670	15.9 cm
373K	100°C	0.686	2.210E-05	80K	3.3E-02	1.6E+05	Valid	1.1E+01	9.357	14.7 cm
398K	125°C	0.682	2.478E-05	105K	3.5E-02	1.6E+05	Valid	1.1E+01	9.861	13.9 cm
423K	150°C	0.680	2.758E-05	130K	3.7E-02	1.5E+05	Valid	1.1E+01	10.258	13.4 cm

Appendix B

WEB HANDLING DETAILS

9.4 Index Roller Wrap Angle

Torque is transmitted to the foil by the capstan effect, and as can be seen from the equation, the greater the wrap angle (θ), the greater the tension difference ($T_1 - T_2$) across the roller can be:

$$\frac{T_1}{T_2} = e^{\mu\theta}. \quad (9.1)$$

9.5 Minimum Roller Size

The index and idler rollers cannot be size arbitrarily. Too big, and they won't fit inside the oven, too small, and the foil will be plastically deformed. Besides making handling the foil more challenging, such a deformation would invalidate the experimental results. Combining the moment-curvature relation,

$$\frac{1}{\rho} = \frac{M}{EI}, \quad (9.2)$$

and relation of stress to moment in pure bending,

$$\sigma = \frac{My}{I}, \quad (9.3)$$

yields:

$$\sigma = \frac{Ey}{2\rho}. \quad (9.4)$$

With Equation 9.4, it was found that using rollers with a radius of 1.5" would result in stress equal to only 10% of the yield stress of DUT material.

9.6 Index Roller Size

As mentioned earlier, a stepper motor is used to drive the index roller. A stepper motor was chosen because the inherently discreet nature of its motion was perfectly suited to the application. Some species of DC motor could have been used as a servo instead, but that would have considerably complicated the control electronics. Running the stepper in half step mode (400 steps per revolution), a roller with a diameter of 3.183 inches creates index steps of the required 0.025 inches. This result fit in nicely with the previous calculation to find the minimum roller size.

9.7 Slip Clutch

To maintain tension in the foil, a slip clutch was attached to the shaft of the supply spool. The temperature was too great to use a magnetic particle brake, and rotary pneumatic actuators were not capable of continuous rotation. The disk based clutch (Figure 9.1) was designed based on both the constant pressure and constant wear assumptions. To facilitate debugging and robustness, the clutch was designed to be adjustable up to twice the anticipated slip torque. To ensure that the necessary temperature extremes could be accommodated, Graphalloy thrust bearings were used for the disks and a stainless steel spring supplied the compressive force.

Uniform Wear Assumption [Shigley, 646]:

$$\Gamma = \frac{F\mu(D+d)}{4}, \quad (9.5)$$

Constant Pressure Assumption [Shigley, 646]:

$$\Gamma = \frac{F\mu(D^3 - d^3)}{3(D^2 - d^2)} \tag{9.6}$$

where D is the outer diameter of the disk, d is the inner diameter, μ is the coefficient of friction, and F is the spring force.

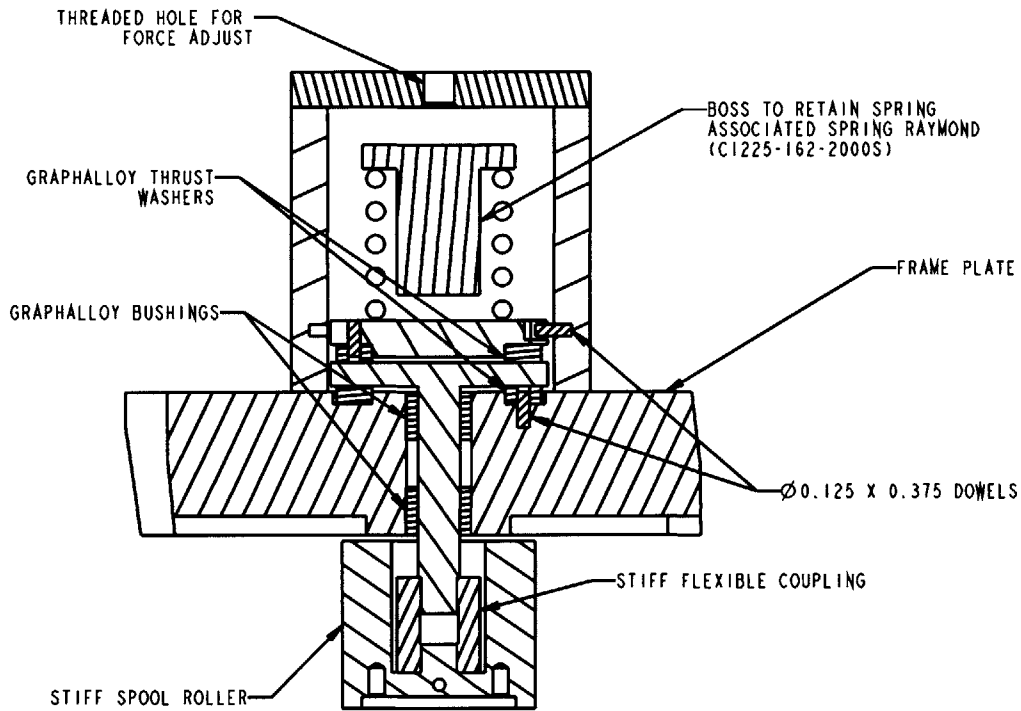

Figure 9.1 A cross section of the slip clutch

9.8 Idler Rotation Disk

Designed for use with a fiber-optic sensor, the idler disk resembles a gear. As the indentations around the disk’s periphery pass beneath the sensor, the edges are detected. If too many index cycles pass without the sensor detecting an edge, the controller logs an error that the foil is not moving, and the test is paused.

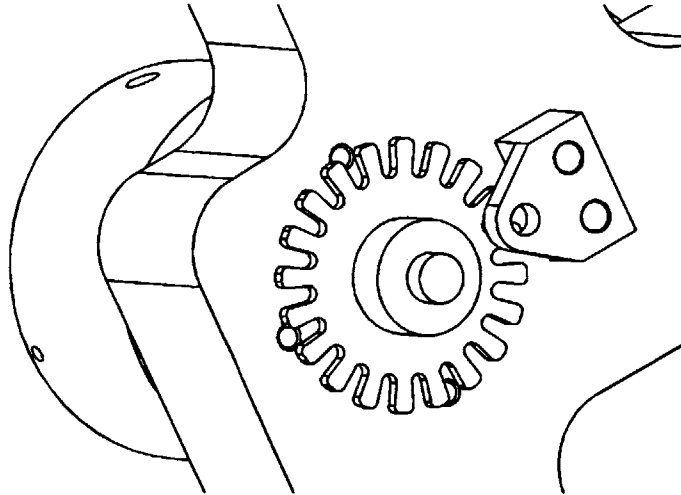
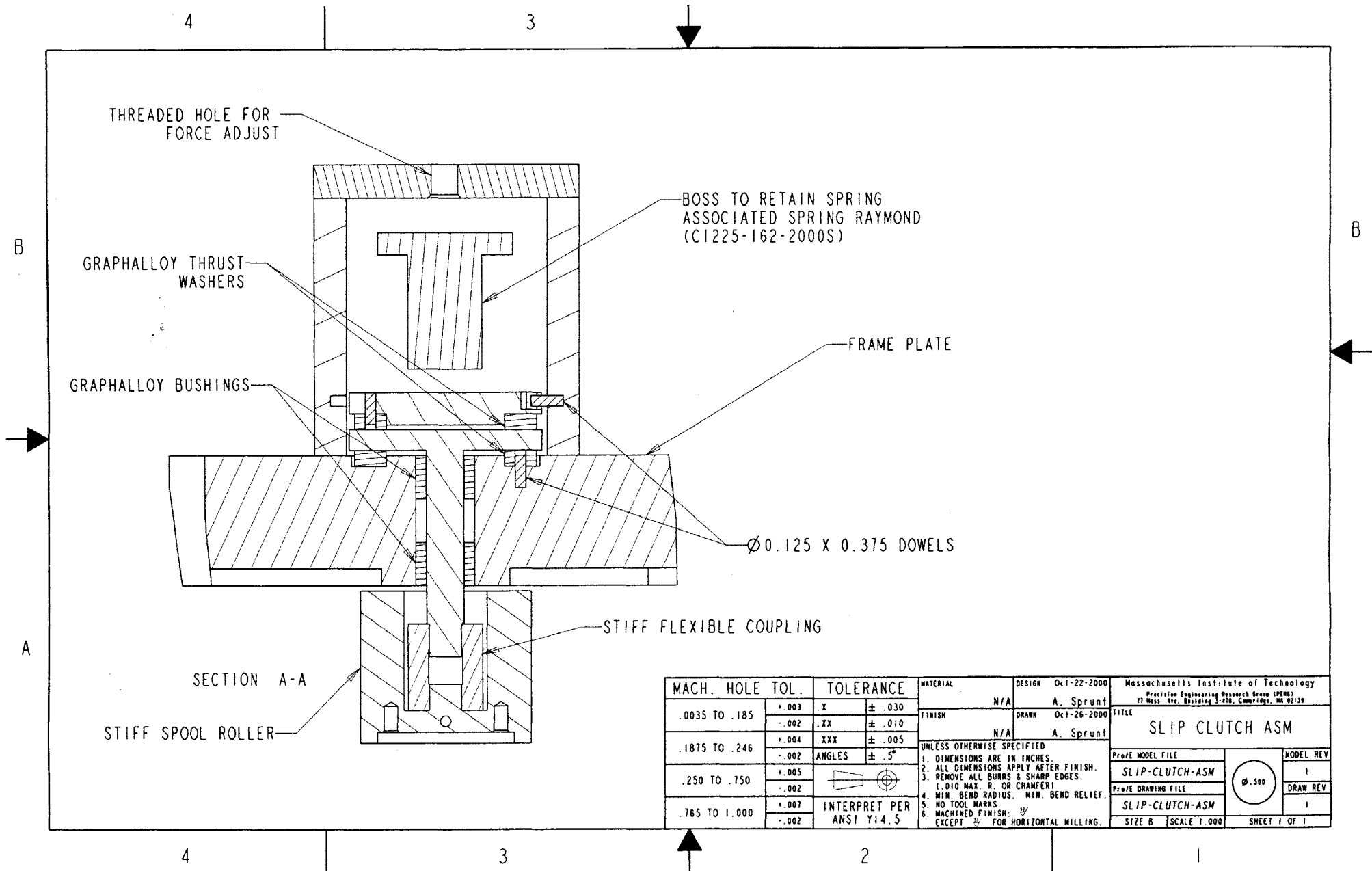

Figure 9.2 The idler rotation disk mounted to the shaft of the idler roller. The fiber optic sensor is mounted in the small hole in the bracket to the right of the disk.

Appendix C

PART AND ASSEMBLY DRAWINGS

The following pages are the part and assembly drawings for the machine.



THREADED HOLE FOR FORCE ADJUST

BOSS TO RETAIN SPRING ASSOCIATED SPRING RAYMOND (C1225-162-2000S)

FRAME PLATE

GRAPHALLOY THRUST WASHERS

GRAPHALLOY BUSHINGS

Ø0.125 X 0.375 DOWELS

STIFF FLEXIBLE COUPLING

SECTION A-A

STIFF SPOOL ROLLER

MACH. HOLE TOL.	TOLERANCE	MATERIAL	DESIGN	Oct-22-2000	Massachusetts Institute of Technology
.0035 TO .185	+ .003 X ± .030	N/A	A. Sprunt		Precision Engineering Research Group (PERG) 77 Mass. Ave. Building 3-218, Cambridge, MA 02139
	- .002 .XX ± .010	FINISH	Oct-26-2000		TITLE
.1875 TO .246	+ .004 .XXX ± .005	N/A	A. Sprunt		SLIP CLUTCH ASM
	- .002 ANGLES ± .5°	UNLESS OTHERWISE SPECIFIED			PROFE MODEL FILE
.250 TO .750	+ .005	1. DIMENSIONS ARE IN INCHES.			SLIP-CLUTCH-ASM
	- .002	2. ALL DIMENSIONS APPLY AFTER FINISH.			PROFE DRAWING FILE
		3. REMOVE ALL BURRS & SHARP EDGES. (.010 MAX. R. OR CHAMFER)			MODEL REV
		4. MIN. BEND RADIUS. MIN. BEND RELIEF.			1
		5. NO TOOL MARKS.			DRAW REV
.765 TO 1.000	+ .007 INTERPRET PER ANSI Y14.5	6. MACHINED FINISH: ψ			1
	- .002	EXCEPT ψ FOR HORIZONTAL MILLING.			SIZE B SCALE 1:000 SHEET 1 OF 1



4

3



B

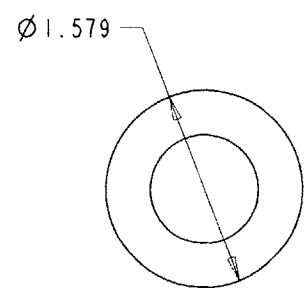
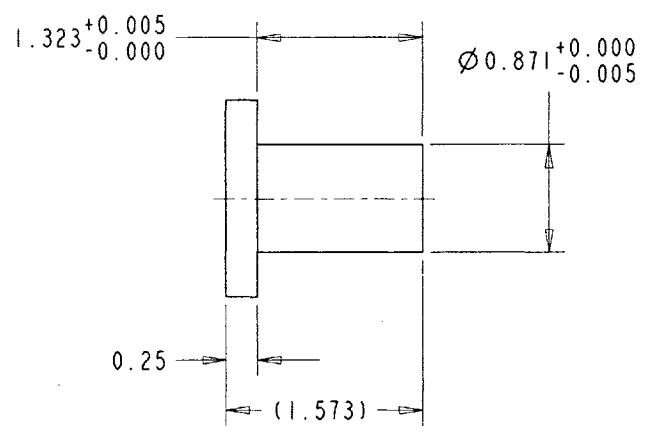

B



A

4

3



2

1

MACH. HOLE TOL.		TOLERANCE		MATERIAL	DESIGN Oct-22-2000	Massachusetts Institute of Technology	
.0035 TO .185		.003	.X	± .030	304 STAINLESS	A. Sprunt	Precision Engineering Research Group (PERG)
		.002	.XX	± .010	FINISH	DRABN Oct-26-2000	17 Mass. Ave. Building 3-470, Cambridge, MA 02139
.1875 TO .246		.004	.XXX	± .005		A. Sprunt	TITLE
		.002	ANGLES	± .5°	UNLESS OTHERWISE SPECIFIED		SPRING STOP 1225
.250 TO .750		.005			1. DIMENSIONS ARE IN INCHES.		Pre/E MODEL FILE
		.002			2. ALL DIMENSIONS APPLY AFTER FINISH.		SPRING-STOP-1225
.765 TO 1.000		.007	INTERPRET PER		3. REMOVE ALL BURRS & SHARP EDGES. (.010 MAX. R. OR CHAMFER)		Pre/E DRAWING FILE
		.002	ANSI Y14.5		4. MIN. BEND RADIUS. MIN. BEND RELIEF.		SPRING-STOP-1225
					5. NO TOOL MARKS.		SIZE B
					6. MACHINED FINISH: ∇		SCALE 1.000
					EXCEPT ∇ FOR HORIZONTAL MILLING.		SHEET 1 OF 1



MODEL REV	1
DRAW REV	1

4

3



B

B

2X 0.564

4X 0.318

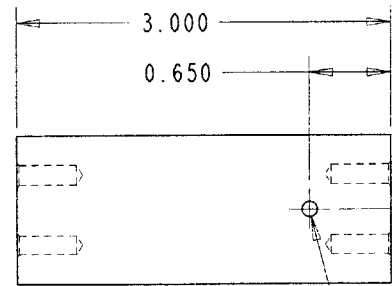

$\varnothing 0.1245^{+0.0005}_{-0.0005} 0.188 \nabla$

2X 0.188

1.200

4X 0.159 (DRILL 21) 10-32
UNF-2B FULL THREAD 0.5



A

4

3



2

1

MACH. HOLE TOL.	TOLERANCE	MATERIAL	DESIGN	Massachusetts Institute of Technology Precision Engineering Research Group (PERG) 77 Mass. Ave. Building 3-418, Cambridge, MA 02139								
.0035 TO .185	+ .003 - .002 .XX ± .030 ± .010	AL6061-T651	Oct-22-2000 A. Sprunt	TITLE SLIP CLUTCH STANDOFF								
.1875 TO .246	+ .004 - .002 .XXX ± .005 ANGLES ± .5°		Oct-26-2000 A. Sprunt									
.250 TO .750	+ .005 - .002	UNLESS OTHERWISE SPECIFIED 1. DIMENSIONS ARE IN INCHES. 2. ALL DIMENSIONS APPLY AFTER FINISH. 3. REMOVE ALL BURRS & SHARP EDGES. (.010 MAX. R. OR CHAMFER) 4. MIN. BEND RADIUS. MIN. BEND RELIEF. 5. NO TOOL MARKS. 6. MACHINED FINISH: ∇ EXCEPT ∇ FOR HORIZONTAL MILLING.	<table border="1"> <tr> <td>Proj# MODEL FILE</td> <td>MODEL REV</td> </tr> <tr> <td>SLIP-CLUTCH-STANDOFF</td> <td>1</td> </tr> <tr> <td>Proj# DRAWING FILE</td> <td>DRAW REV</td> </tr> <tr> <td>SLIP-CLUTCH-STANDOFF</td> <td>1</td> </tr> </table>		Proj# MODEL FILE	MODEL REV	SLIP-CLUTCH-STANDOFF	1	Proj# DRAWING FILE	DRAW REV	SLIP-CLUTCH-STANDOFF	1
Proj# MODEL FILE	MODEL REV											
SLIP-CLUTCH-STANDOFF	1											
Proj# DRAWING FILE	DRAW REV											
SLIP-CLUTCH-STANDOFF	1											
.765 TO 1.000	+ .007 - .002 INTERPRET PER ANSI Y14.5		SIZE B	SCALE 1.000								



SHEET 1 OF 1

4

3



DETAIL A
SCALE 3.000

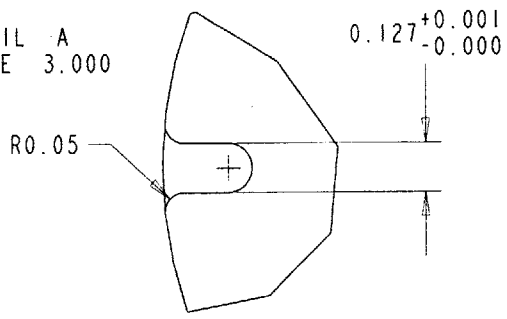

B

B

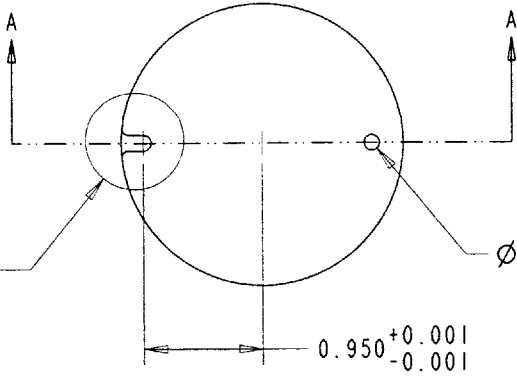

SEE DETAIL A

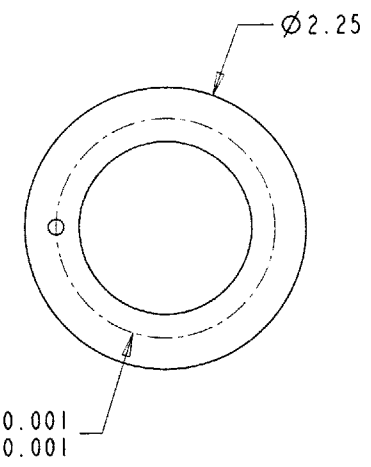
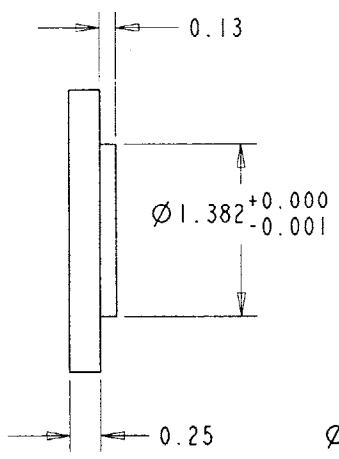

A

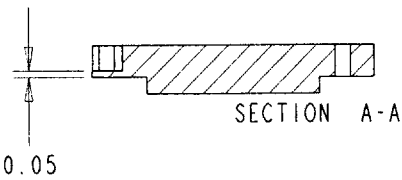

4

3



2

1

MACH. HOLE TOL.		TOLERANCE		MATERIAL	DESIGN	Massachusetts Institute of Technology Precision Engineering Research Group (PERG) 77 Mass. Ave. Building 3-210, Cambridge, MA 02139	
.0035 TO .185	+ .003	.X	± .030	304 STAINLESS	Oct-22-2000	A. Sprunt	
	- .002	.XX	± .010		Oct-26-2000	DRAWN A. Sprunt	
.1875 TO .246	+ .004	.XXX	± .005	UNLESS OTHERWISE SPECIFIED 1. DIMENSIONS ARE IN INCHES. 2. ALL DIMENSIONS APPLY AFTER FINISH. 3. REMOVE ALL BURRS & SHARP EDGES. (.010 MAX. R. OR CHAMFER) 4. MIN. BEND RADIUS. MIN. BEND RELIEF. 5. NO TOOL MARKS. 6. MACHINED FINISH: ψ EXCEPT ψ FOR HORIZONTAL MILLING.	TITLE		
	- .002	ANGLES	± 5°		PRESSURE PLATE		
.250 TO .750	+ .005		INTERPRET PER ANSI Y14.5	PRO/E MODEL FILE			MODEL REV
	- .002			PRESSURE-PLATE			I
.765 TO 1.000	+ .007	INTERPRET PER ANSI Y14.5	INTERPRET PER ANSI Y14.5	PRO/E DRAWING FILE			DRAW REV
	- .002			PRESSURE-PLATE			I
				SIZE B SCALE 1.000		SHEET 1 OF 1	

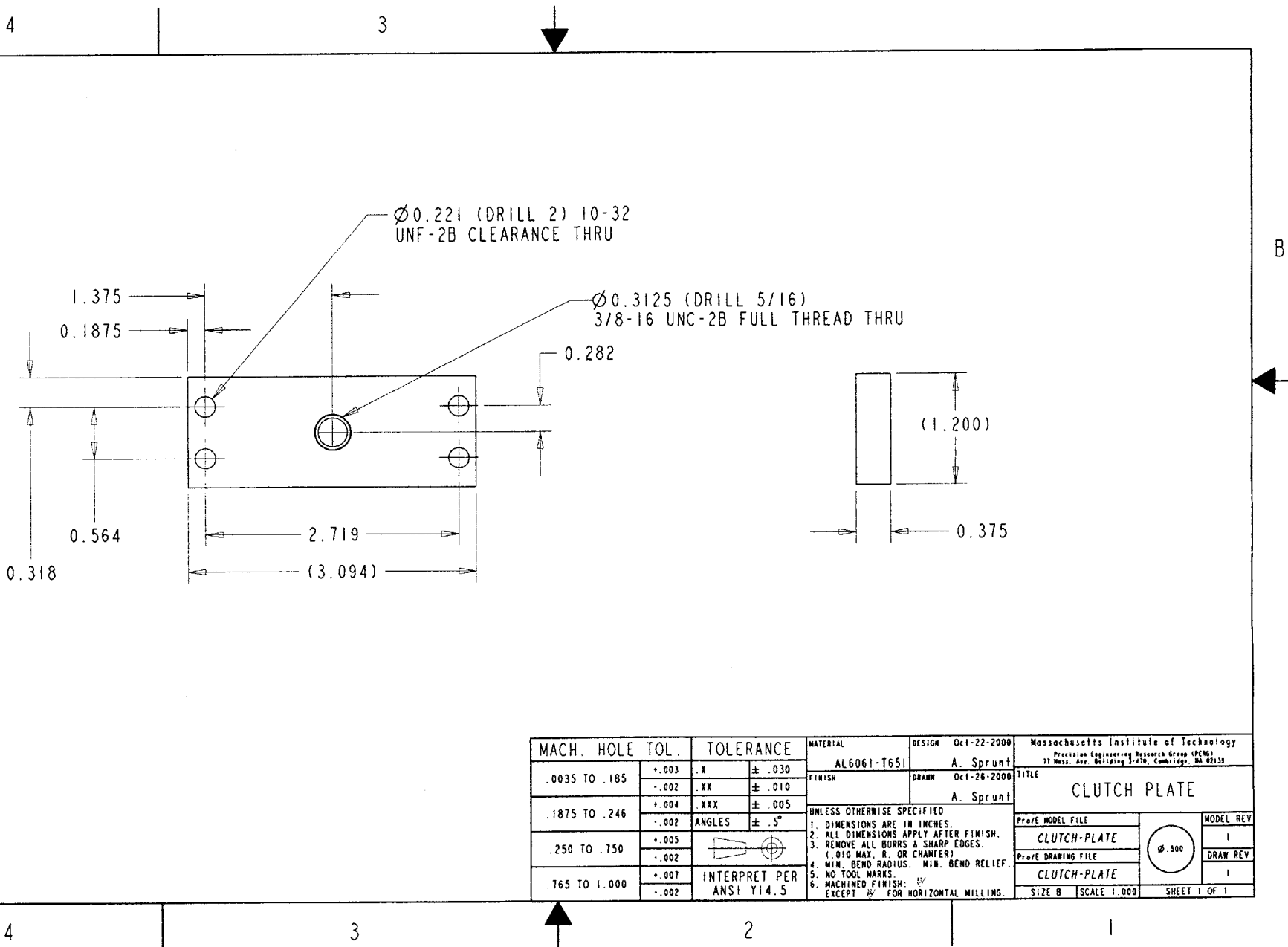

MACH. HOLE TOL.		TOLERANCE		MATERIAL	DESIGN	Massachusetts Institute of Technology Precision Engineering Research Group (PERG) 37 Resz. Ave. Building 3-470, Cambridge, MA 02139	
.0035 TO .185	+ .003	.X	± .030	AL6061-T651	Oct-22-2000	A. Sprunt	
	- .002	.XX	± .010		Oct-26-2000	A. Sprunt	
.1875 TO .246	+ .004	.XXX	± .005	UNLESS OTHERWISE SPECIFIED	1. DIMENSIONS ARE IN INCHES. 2. ALL DIMENSIONS APPLY AFTER FINISH. 3. REMOVE ALL BURRS & SHARP EDGES. 4. 0.010 MAX. R. OR CHAMFER. 5. MIN. BEND RADIUS. MIN. BEND RELIEF. 6. NO TOOL MARKS. 7. MACHINED FINISH: $\sqrt{\text{W}}$ EXCEPT $\sqrt{\text{W}}$ FOR HORIZONTAL MILLING.		
	- .002	ANGLES	± .5°				
.250 TO .750	+ .005		INTERPRET PER ANSI Y14.5				
	- .002						
.765 TO 1.000	+ .007						
	- .002						

TITLE		CLUTCH-PLATE	
Proj/E MODEL FILE		MODEL REV	I
CLUTCH-PLATE		DRAW REV	I
Proj/E DRAWING FILE	CLUTCH-PLATE	SHEET 1 OF 1	
SIZE B	SCALE 1.000		

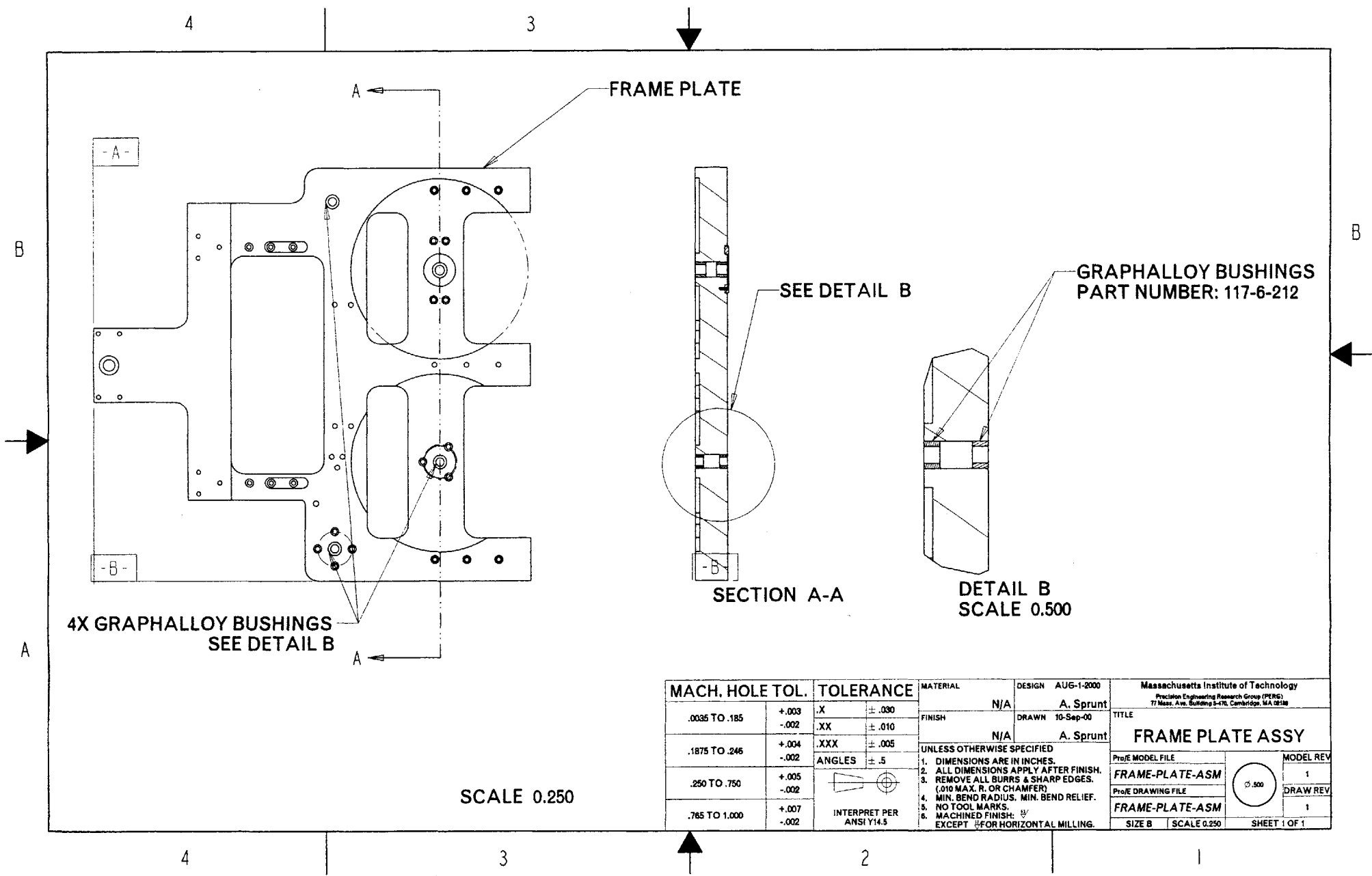

FRAME PLATE

GRAPHALLOY BUSHINGS
PART NUMBER: 117-6-212

SEE DETAIL B

SECTION A-A

DETAIL B
SCALE 0.500

4X GRAPHALLOY BUSHINGS
SEE DETAIL B

SCALE 0.250

MACH. HOLE TOL.		TOLERANCE		MATERIAL	DESIGN	Massachusetts Institute of Technology Precision Engineering Research Group (PERG) 77 Mass. Ave. Building 3-476, Cambridge, MA 02138	
.0035 TO .185	+ .003 - .002	.X .XX	± .030 ± .010	N/A	AUG-1-2000	TITLE	
.1875 TO .246	+ .004 - .002	.XXX	± .005	N/A	10-Sep-00	FRAME PLATE ASSY	
.250 TO .750	+ .005 - .002	ANGLES	± .5	UNLESS OTHERWISE SPECIFIED			
.765 TO 1.000	+ .007 - .002	INTERPRET PER ANSI Y14.5		1. DIMENSIONS ARE IN INCHES. 2. ALL DIMENSIONS APPLY AFTER FINISH. 3. REMOVE ALL BURRS & SHARP EDGES. (.010 MAX. R. OR CHAMFER) 4. MIN. BEND RADIUS. MIN. BEND RELIEF. 5. NO TOOL MARKS. 6. MACHINED FINISH: ψ EXCEPT ψ FOR HORIZONTAL MILLING.			
Pro/E MODEL FILE						MODEL REV	
FRAME-PLATE-ASM						1	
Pro/E DRAWING FILE						DRAW REV	
FRAME-PLATE-ASM						1	
SIZE B SCALE 0.250						SHEET 1 OF 1	

UNLESS SPECIFIED, ROUNDED
CORNERS ARE R0.60

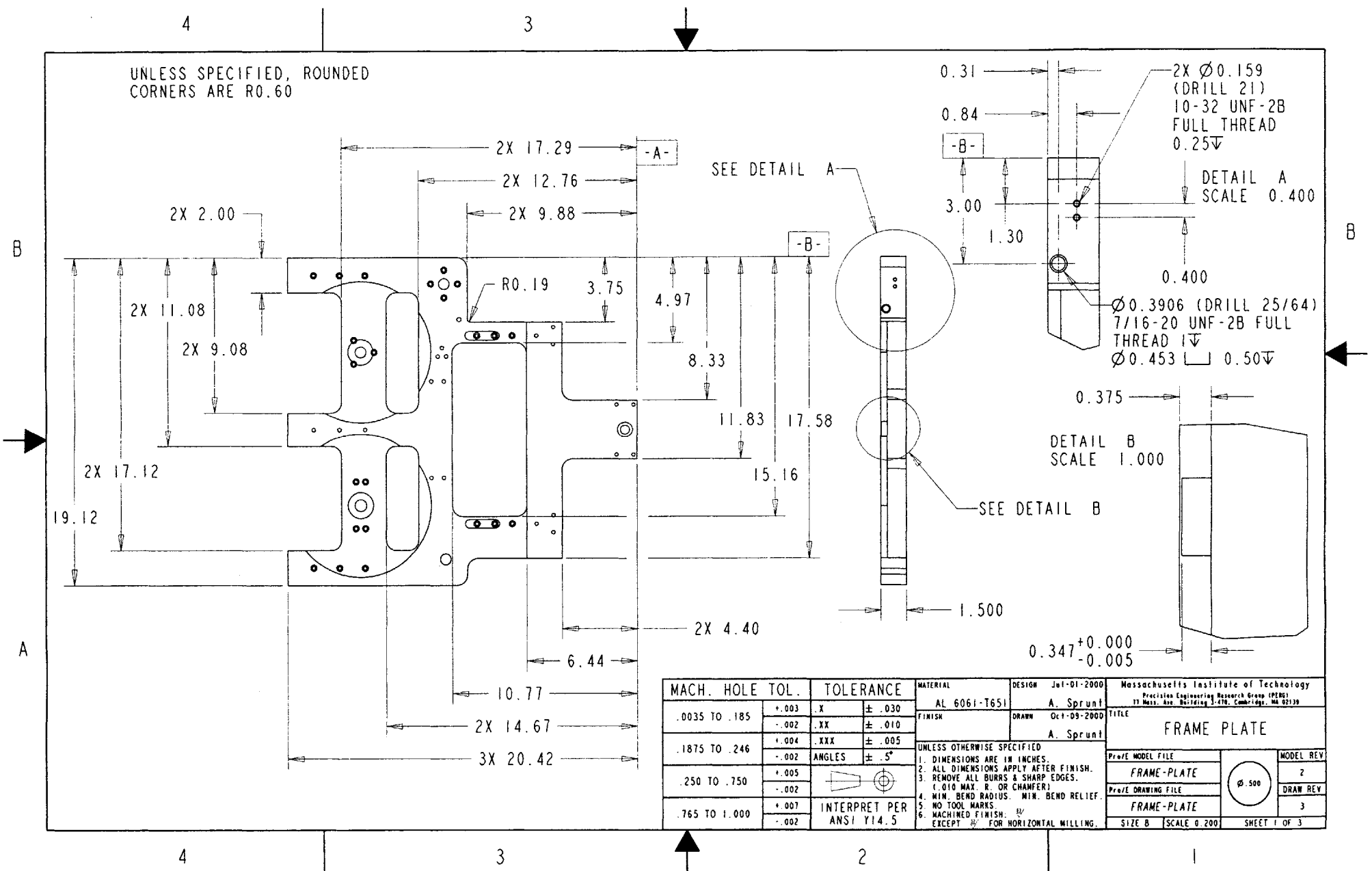

MACH. HOLE TOL.	TOLERANCE	MATERIAL	DESIGN	Massachusetts Institute of Technology Precision Engineering Research Group (PERG) 77 Mass. Ave. Building 3-276, Cambridge, MA 02139
.0035 TO .185	+ .003 .X ± .030 - .002 .XX ± .010	AL 6061-T651	Jul-01-2000 A. Sprunt	TITLE FRAME PLATE
.1875 TO .246	+ .004 .XXX ± .005 - .002 ANGLES ± 5°		Oct-09-2000 A. Sprunt	
.250 TO .750	+ .005 - .002	UNLESS OTHERWISE SPECIFIED 1. DIMENSIONS ARE IN INCHES. 2. ALL DIMENSIONS APPLY AFTER FINISH. 3. REMOVE ALL BURRS & SHARP EDGES. 4. 0.010 MAX. R. OR CHAMFER. 5. MIN. BEND RADIUS. MIN. BEND RELIEF. 6. MACHINED FINISH: $\frac{32}{\sqrt{}} \sqrt{\text{IN}}$ EXCEPT $\frac{32}{\sqrt{}}$ FOR HORIZONTAL MILLING.		PROJ MODEL FILE FRAME-PLATE
.765 TO 1.000	+ .007 - .002 INTERPRET PER ANSI Y14.5			PROJ DRAWING FILE FRAME-PLATE

MODEL REV	2
DRAW REV	3
SIZE B	SCALE 0.200
SHEET 1 OF 3	

4

3

4 PLC BC $\varnothing 1.600 \pm 0.005$
 $\varnothing 0.221$ (DRILL 2) 10-32
 UNF-2B CLEARANCE THRU
 $\varnothing 0.375 \perp 1.0 \nabla$

3 PLC BC $\varnothing 1.600 \pm 0.005$
 $\varnothing 0.221$ (DRILL 2) 10-32
 UNF-2B CLEARANCE THRU
 $\varnothing 0.375 \perp 1.0 \nabla$

2X $\varnothing 8.3$
 0.2∇

2X $\varnothing 1.5$

SEE DETAIL C

$\varnothing 0.90$

2X 8.27

-A-

-B-

4.55

15.58

SECTION Z-Z

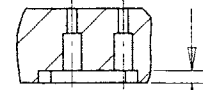

0.25

DETAIL C
 SCALE 0.400

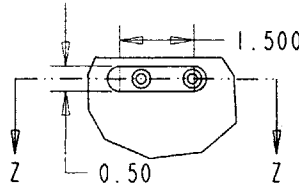

HOLE TABLE B $\varnothing \pm 0.005$

A	B	SIZE	COUNTERBORE
8.307	4.545		
9.339	4.545		
8.307	15.579		$\varnothing 0.375 \perp 0.75 \nabla$
9.339	15.579		
15.920	1.000		
17.420	1.000		
18.920	1.000	$\varnothing 0.221$ (DRILL 2) 10-32 2B CLEARANCE THRU	$\varnothing 0.375 \perp 1.0 \nabla$
7.276	4.545		
7.276	15.579		
15.888	13.125		
16.452	13.125		$\varnothing 0.375 \perp 0.8 \nabla$
15.888	15.844		
16.452	15.844		
15.920	18.124		
17.420	18.124		$\varnothing 0.375 \perp 1.0 \nabla$
18.920	18.124		

HOLE TABLE A $\varnothing \pm 0.005$

A	B	SIZE
11.262	1.500	
16.170	5.500	0.627 0.625
11.170	17.624	
16.170	14.500	0.689 0.687
0.725	10.077	0.550 ^{+0.002} -0.000 (H9)

MACH. HOLE TOL.	TOLERANCE	MATERIAL	DESIGN	Massachusetts Institute of Technology Precision Engineering Research Group (PERG) 77 Mass. Ave. Building 3-410, Cambridge, MA 02139
.0035 TO .185	+ .003 - .002 .XX $\pm .030$ $\pm .010$	AL 6061-T651	Jul-01-2000 A. Sprunt	
.1875 TO .246	+ .004 - .002 ANGLES $\pm .5^\circ$		Oct-09-2000 A. Sprunt	TITLE FRAME PLATE
.250 TO .750	+ .005 - .002	UNLESS OTHERWISE SPECIFIED: 1. DIMENSIONS ARE IN INCHES. 2. ALL DIMENSIONS APPLY AFTER FINISH. 3. REMOVE ALL BURRS & SHARP EDGES. (.010 MAX. R. OR CHAMFER) 4. MIN. BEND RADIUS. MIN. BEND RELIEF. 5. NO TOOL MARKS. 6. MACHINED FINISH: ∇ EXCEPT ∇ FOR HORIZONTAL MILLING.		PROFE MODEL FILE FRAME-PLATE PROFE DRAWING FILE FRAME-PLATE
.765 TO 1.000	+ .007 - .002 INTERPRET PER ANSI Y14.5			MODEL REV 2 DRAW REV 3
				SIZE B SCALE 0.200 SHEET 2 OF 3

4

3

2

1

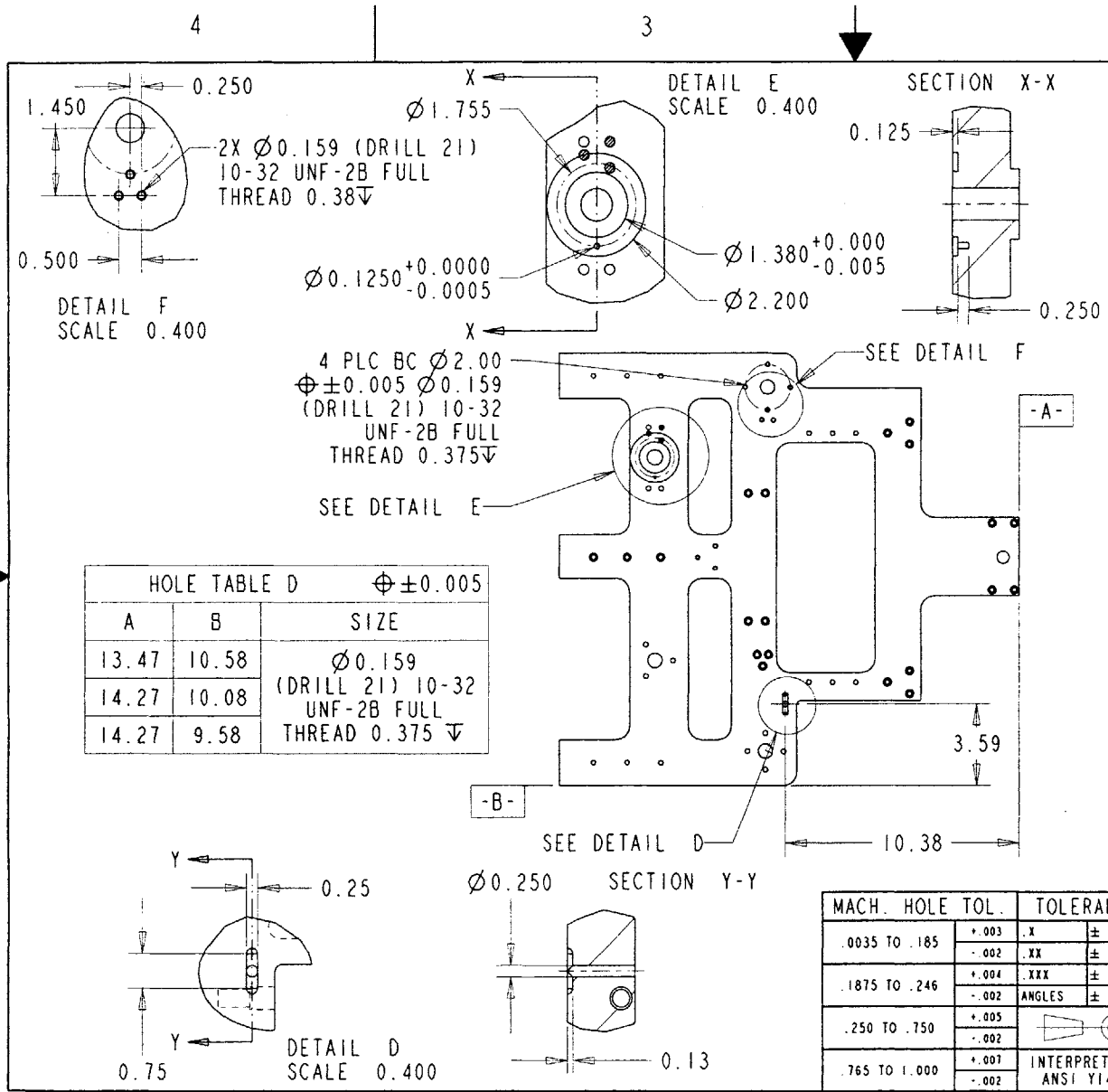

HOLE TABLE C		±0.005	
A	B	SIZE	COUNTERBORE
11.27	12.91	Ø0.221 (DRILL 2) 10-32 UNF-2B CLEARANCE THRU	0.375 L 1.007
12.02	12.91		
15.92	10.08		
17.42	10.08		
18.92	10.08		
11.27	7.22		
12.02	7.22		
11.13	5.75		
11.63	5.75		
11.38	5.25		
4.895	16.079	Ø0.375 L 0.637	
5.895	15.579		
4.895	15.079		
0.215	11.577		
1.215	11.577		
0.215	8.577		
1.215	8.577		
4.895	5.045		
5.895	4.545		
4.895	4.045		

HOLE TABLE D		±0.005
A	B	SIZE
13.47	10.58	Ø0.159 (DRILL 21) 10-32 UNF-2B FULL THREAD 0.3757
14.27	10.08	
14.27	9.58	

MACH. HOLE TOL.	TOLERANCE	MATERIAL	DESIGN	Massachusetts Institute of Technology
.0035 TO .185	+ .003 - .002	AL 6061-T651	Jul-01-2000 A. Sprunt	Precision Engineering Research Group (PERG) 77 Mass. Ave. Building 3-010, Cambridge, MA 02139
.1875 TO .246	+ .004 - .002		Oct-12-2000 A. Sprunt	
.250 TO .750	.XXX ANGLES ± .5°			
.765 TO 1.000	+ .001 - .002			

UNLESS OTHERWISE SPECIFIED:
 1. DIMENSIONS ARE IN INCHES.
 2. ALL DIMENSIONS APPLY AFTER FINISH.
 3. REMOVE ALL BURRS & SHARP EDGES.
 4. MIN. BEND RADIUS. MIN. BEND RELIEF.
 5. NO TOOL MARKS.
 6. MACHINED FINISH: EXCEPT FOR HORIZONTAL MILLING.

PROE MODEL FILE	MODEL REV
FRAME-PLATE	2
PROE DRAWING FILE	
FRAME-PLATE	3

SIZE B SCALE 0.200 SHEET 3 OF 3

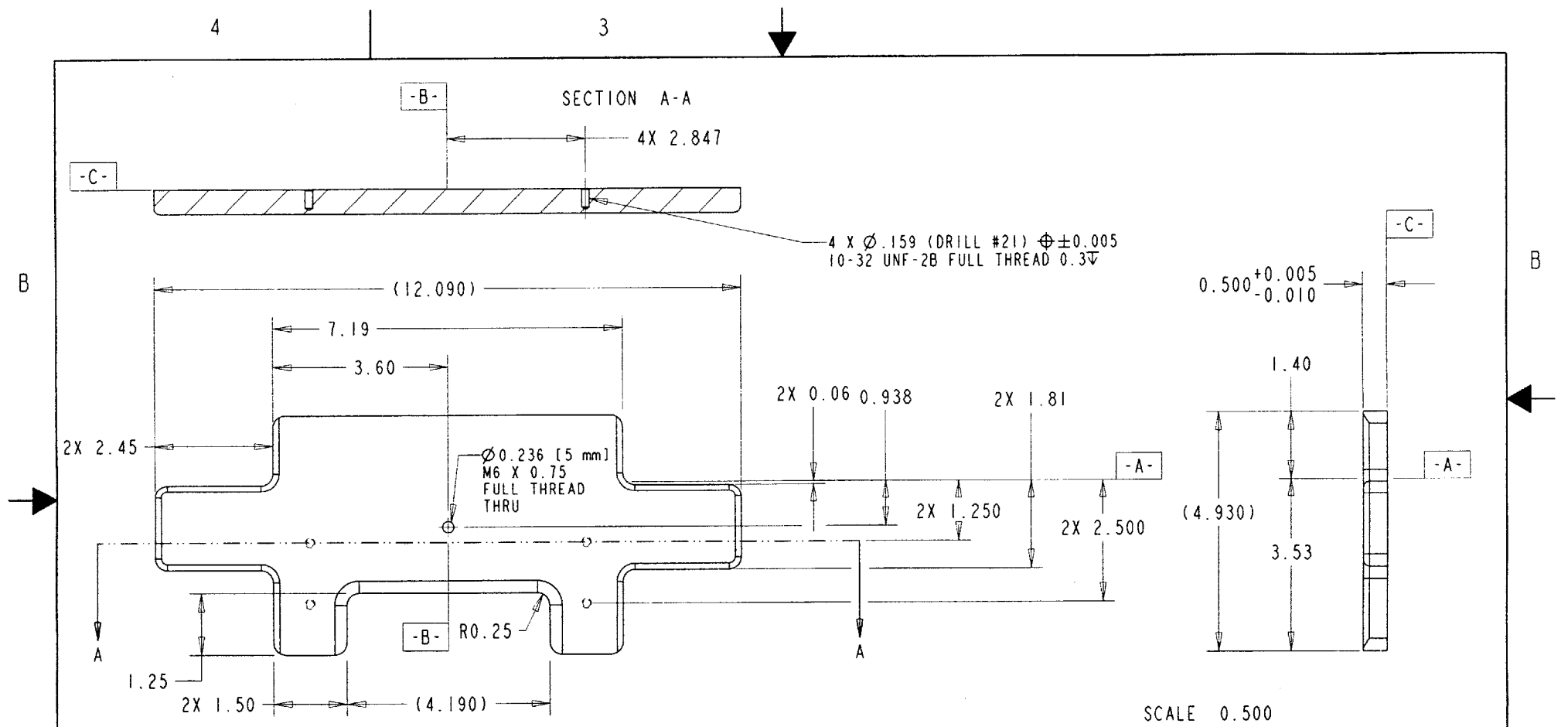

SCALE 0.500

MACH. HOLE TOL.	TOLERANCE	MATERIAL	DESIGN	Massachusetts Institute of Technology
.0035 TO .185	+ .003 - .002 X ± .030	304 STAINLESS	Aug-15-2000 A. Sprunt	Precision Engineering Research Group (PERG) 77 Mass. Ave. Building 3-070, Cambridge, MA 02138
.1875 TO .246	+ .004 - .002 XXX ± .005	FINISH	Nov-15-2000 A. Sprunt	TITLE Plunge Plate
.250 TO .750	+ .005 - .002 ANGLES ± 5°	UNLESS OTHERWISE SPECIFIED		Prj/E MODEL FILE
.765 TO 1.000	+ .007 - .002 INTERPRET PER ANSI Y14.5	1. DIMENSIONS ARE IN INCHES 2. ALL DIMENSIONS APPLY AFTER FINISH. 3. REMOVE ALL BURRS & SHARP EDGES. (.010 MAX. R. OR CHAMFER) 4. MIN. BEND RADIUS. MIN. BEND RELIEF. 5. NO TOOL MARKS. 6. MACHINED FINISH: ✪ EXCEPT ✪ FOR HORIZONTAL MILLING.		Prj/E DRAWING FILE
				MODEL REV 2
				DRAW REV 2
				SIZE B SCALE 0.750 SHEET 1 OF 1

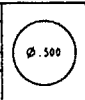

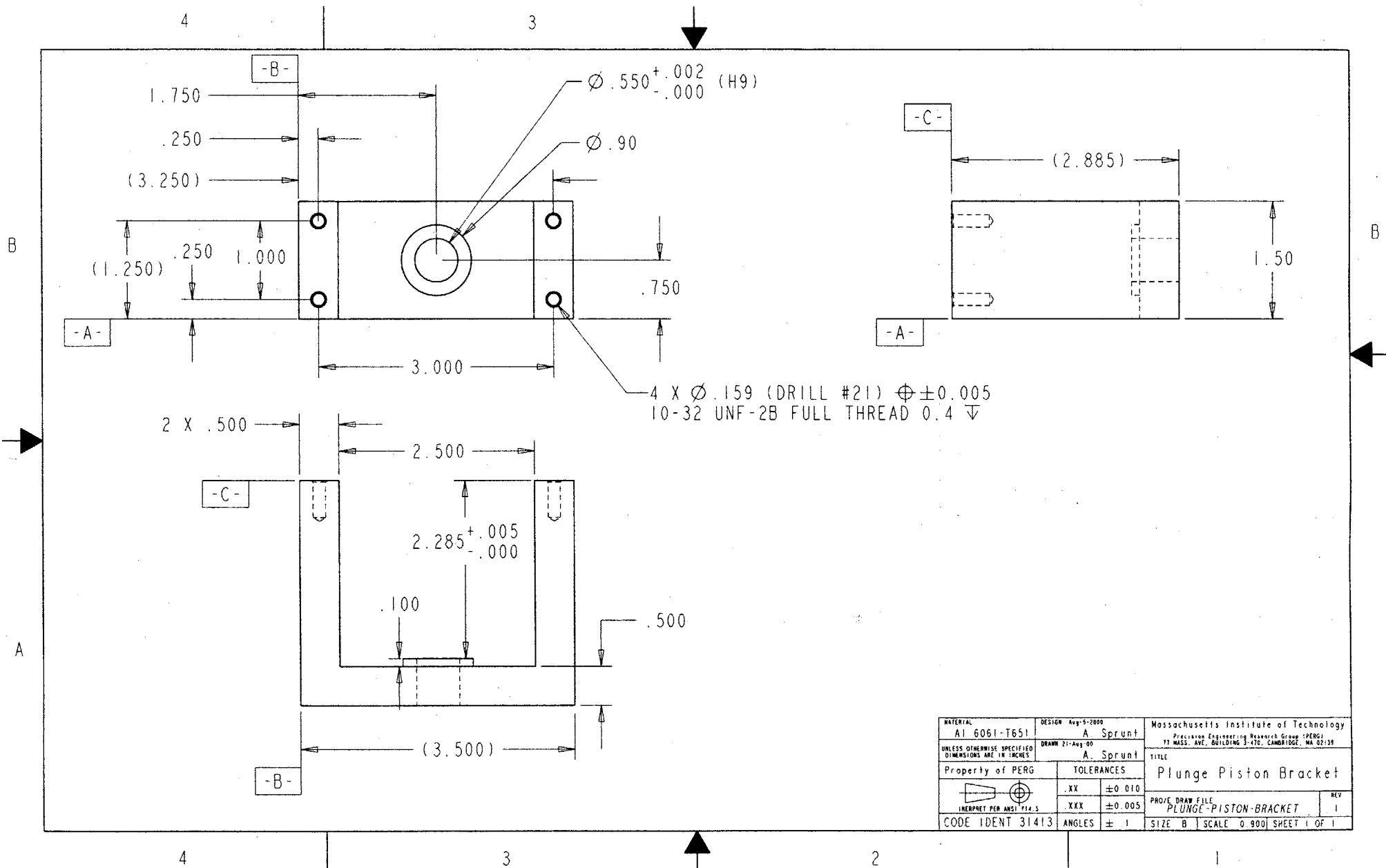

MATERIAL Al 6061-T651	DESIGN Aug-5-2000 A Sprunt	Massachusetts Institute of Technology Precision Engineering Research Group (PERG) 77 MASS. AVE., BUILDING 3-47C, CAMBRIDGE, MA 02139
UNLESS OTHERWISE SPECIFIED DIMENSIONS ARE IN INCHES	DRAWN 21-Aug-00 A. Sprunt	TITLE Plunge Piston Bracket
Property of PERG	TOLERANCES	PROJ. DRAW FILE PLUNGE-PISTON-BRACKET
	.XX ± 0.010	REV 1
	.XXX ± 0.005	SCALE 0.9001
CODE IDENT 31413	ANGLES ± 1	SHEET 1 OF 1

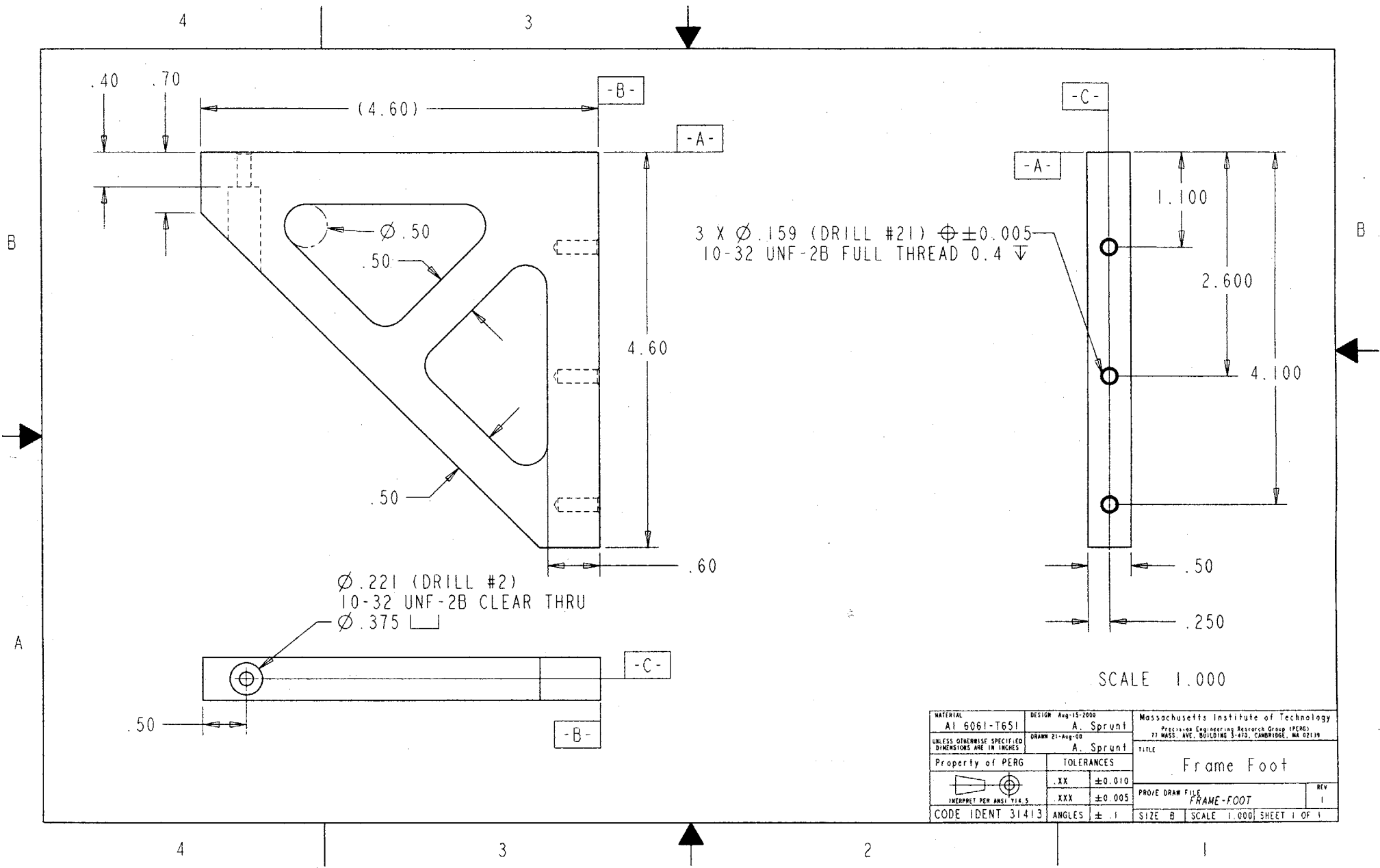

MATERIAL Al 6061-T651	DESIGN Aug-15-2000	Massachusetts Institute of Technology	
UNLESS OTHERWISE SPECIFIED DIMENSIONS ARE IN INCHES	DRAWN 21-Aug-00	Precision Engineering Research Group (PERG) 77 MASS. AVE. BUILDING 3-413, CAMBRIDGE, MA 02139	
Property of PERG	TOLERANCES	TITLE Frame Foot	
	.XX ± 0.010	PROJ/ DRAW FILE FRAME-FOOT	REV 1
CODE IDENT 31413	ANGLES $\pm .1$	SIZE B	SCALE 1.000 SHEET 1 OF 1

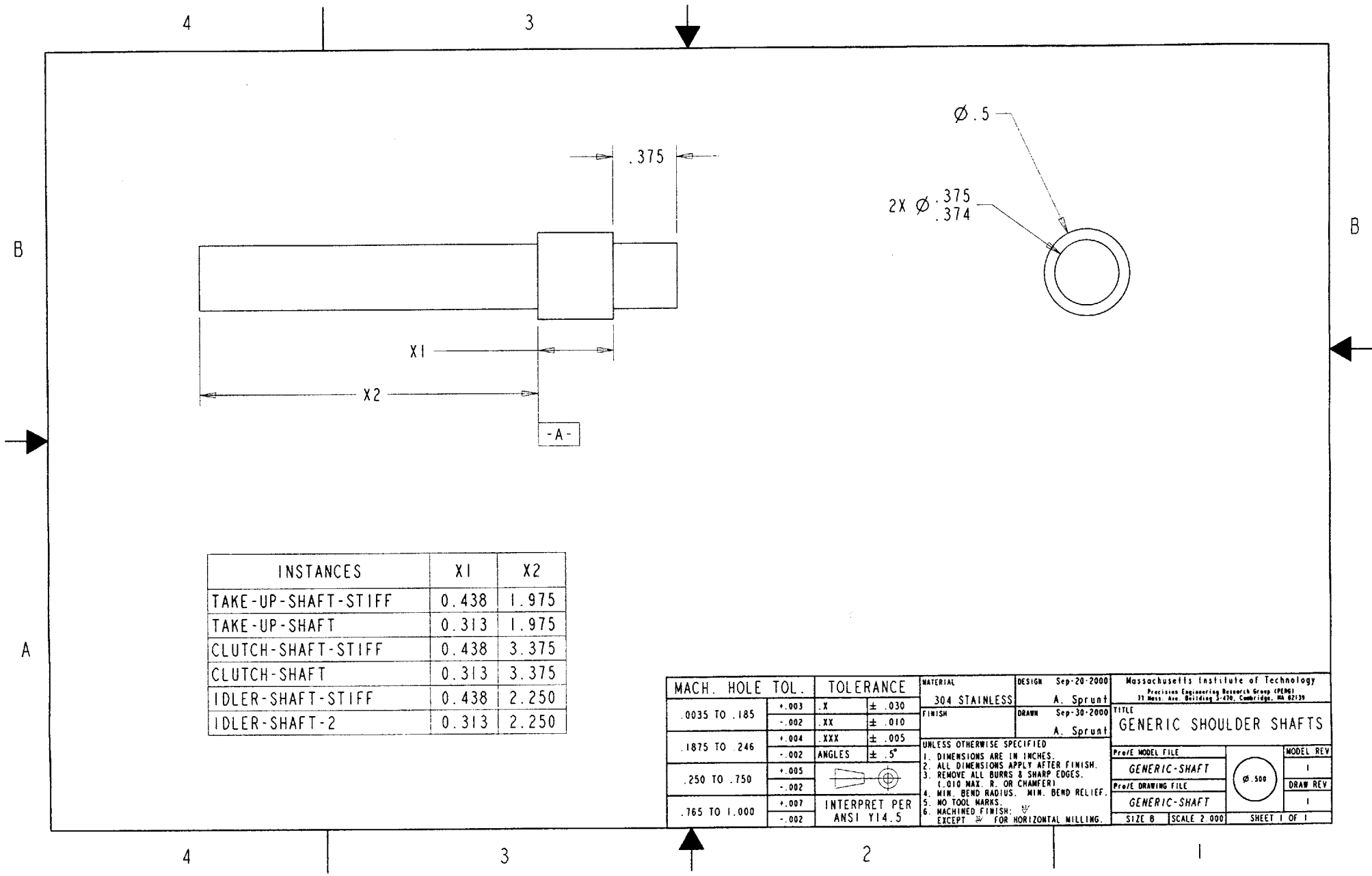

INSTANCES	X1	X2
TAKE-UP-SHAFT-STIFF	0.438	1.975
TAKE-UP-SHAFT	0.313	1.975
CLUTCH-SHAFT-STIFF	0.438	3.375
CLUTCH-SHAFT	0.313	3.375
IDLER-SHAFT-STIFF	0.438	2.250
IDLER-SHAFT-2	0.313	2.250

MACH. HOLE TOL.	TOLERANCE	MATERIAL	DESIGN	Massachusetts Institute of Technology Precision Engineering Research Group (PERG) 37 Mass. Ave. Building 3-470, Cambridge, MA 02139	
.0035 TO .185	+ .003 - .002	304 STAINLESS	Sep-20-2000 A. Sprunt	TITLE GENERIC SHOULDER SHAFTS	
.1875 TO .246	+ .004 - .002	FINISH	Sep-30-2000 A. Sprunt	PROJECT MODEL FILE GENERIC-SHAFT	MODEL REV 1
.250 TO .750	+ .005 - .002	UNLESS OTHERWISE SPECIFIED 1. DIMENSIONS ARE IN INCHES. 2. ALL DIMENSIONS APPLY AFTER FINISH. 3. REMOVE ALL BURRS & SHARP EDGES. (.010 MAX. R. OR CHAMFER) 4. MIN. BEND RADIUS. MIN. BEND RELIEF. 5. NO TOOL MARKS. 6. MACHINED FINISH: ∇ EXCEPT ∇ FOR HORIZONTAL MILLING.		PROJECT DRAWING FILE GENERIC-SHAFT	DRAW REV 1
.765 TO 1.000	+ .007 - .002	INTERPRET PER ANSI Y14.5		SIZE B	SCALE 2.000



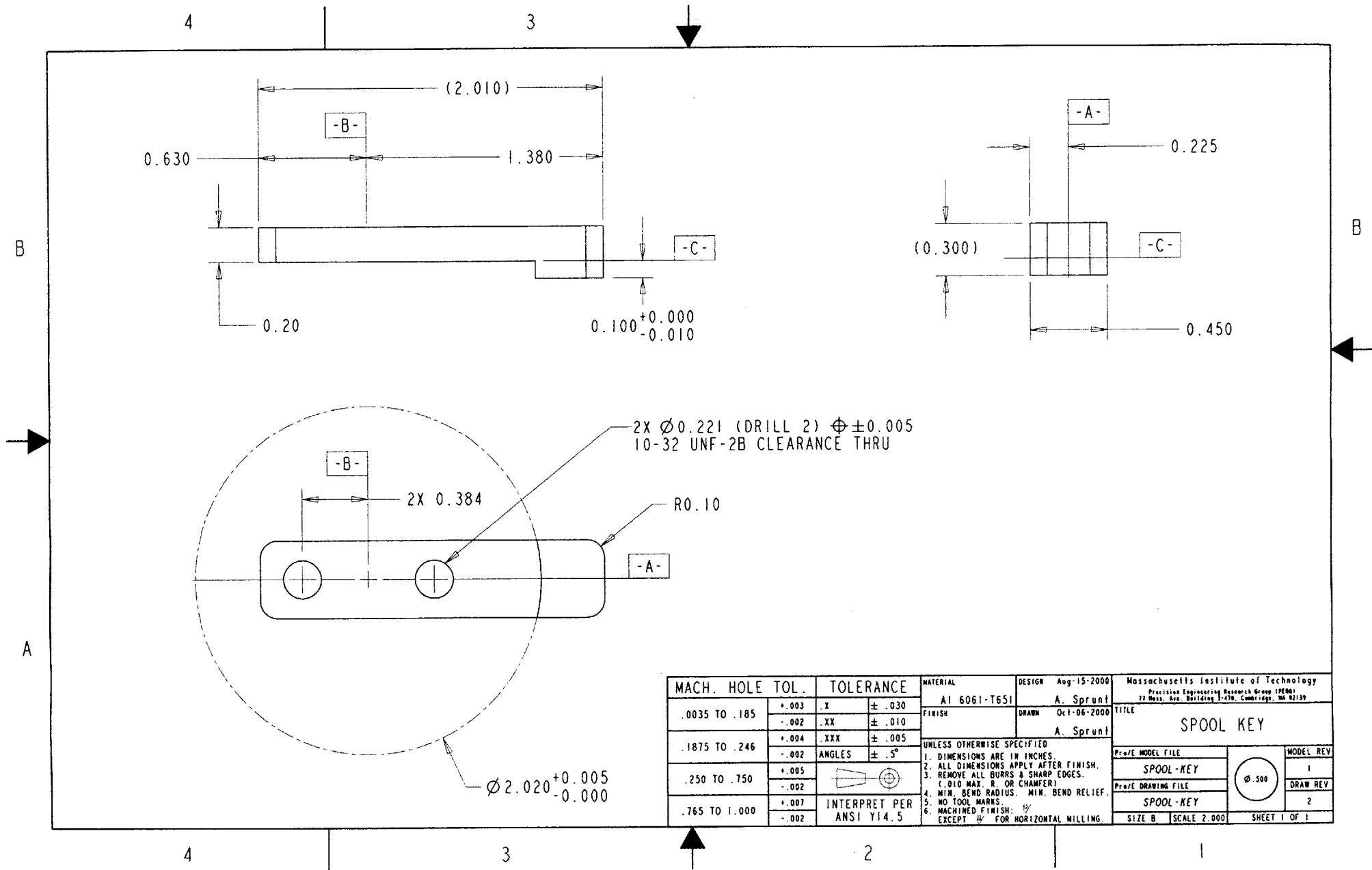

MACH. HOLE TOL.		TOLERANCE		MATERIAL	DESIGN	Massachusetts Institute of Technology	
.0035 TO .185	+ .003 - .002	.X .XX	$\pm .030$ $\pm .010$	Al 6061-T651	Aug-15-2000 A. Sprunt	Precision Engineering Research Group (PERG) 77 Mass. Ave. Building 3-270, Cambridge, MA 02139	
.1875 TO .246	+ .004 - .002	.XXX ANGLES	$\pm .005$ $\pm .5^\circ$	FINISH	DRAWN	TITLE	
.250 TO .750	+ .005 - .002		INTERPRET PER ANSI Y14.5	UNLESS OTHERWISE SPECIFIED		SPPOOL KEY	
.765 TO 1.000	+ .007 - .002			1. DIMENSIONS ARE IN INCHES. 2. ALL DIMENSIONS APPLY AFTER FINISH. 3. REMOVE ALL BURRS & SHARP EDGES. 4. MIN. BEND RADIUS. MIN. BEND RELIEF. 5. NO TOOL MARKS. 6. MACHINED FINISH: ∇ EXCEPT ∇ FOR HORIZONTAL MILLING.		Pro/E MODEL FILE SPPOOL-KEY Pro/E DRAWING FILE SPPOOL-KEY SIZE B SCALE 2.000	MODEL REV 1 DRAW REV 2 SHEET 1 OF 1

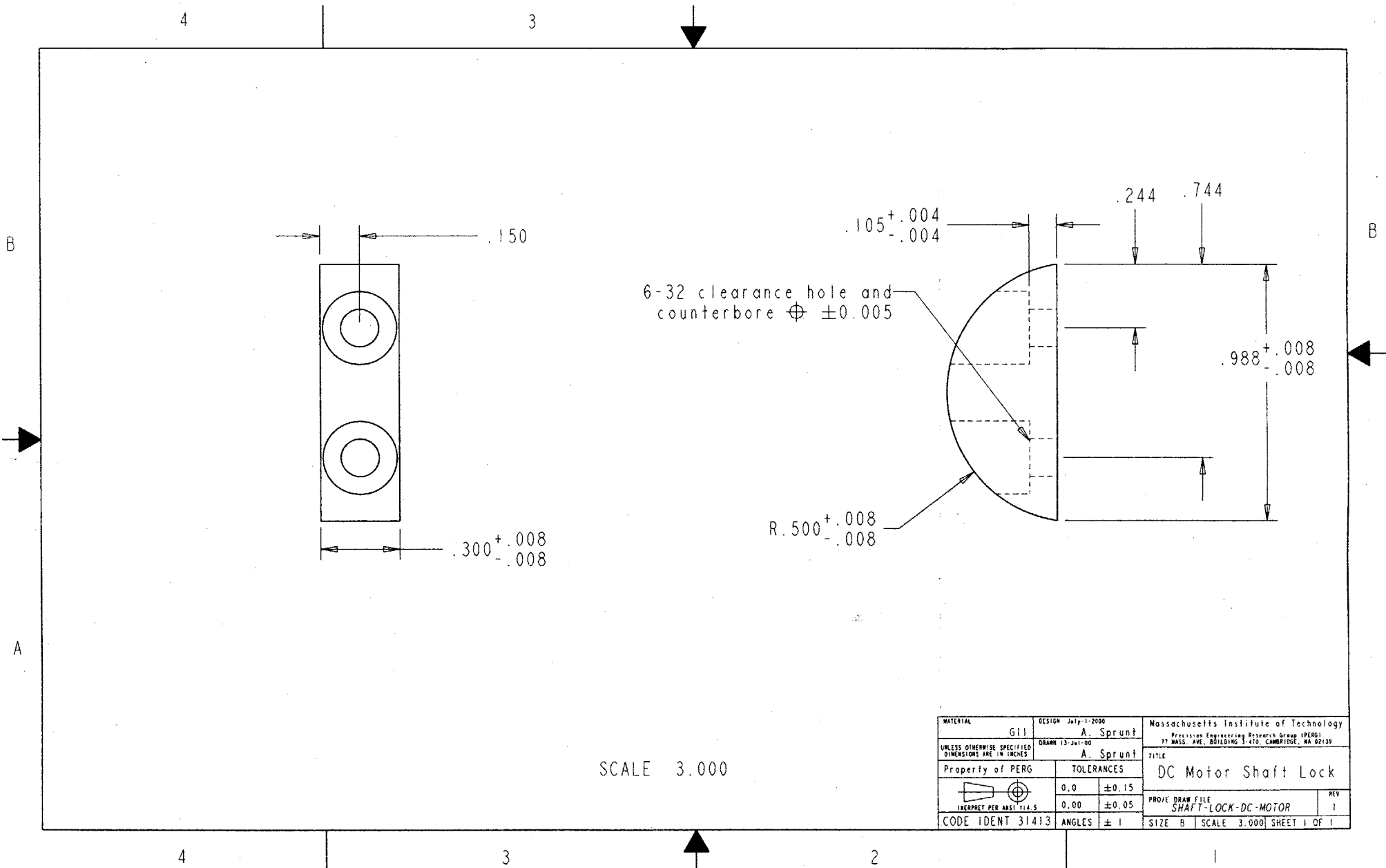

6-32 clearance hole and counterbore $\varnothing \pm 0.005$

SCALE 3.000

MATERIAL	DESIGN	Massachusetts Institute of Technology	
G11	July-1-2000	Precision Engineering Research Group (PERG)	
UNLESS OTHERWISE SPECIFIED DIMENSIONS ARE IN INCHES	DRAWN	77 MASS. AVE. BUILDING 3-470, CAMBRIDGE, MA 02139	
Property of PERG	A. Sprunt	TITLE	
TOLERANCES	A. Sprunt	DC Motor Shaft Lock	
	0.0 ±0.15	PROJ/ DRAW FILE	REV
INTERPRET PER ANSI Y14.5	0.00 ±0.05	SHAFT-LOCK-DC-MOTOR	1
CODE IDENT 31413	ANGLES ± 1	SIZE B	SCALE 3.000 SHEET 1 OF 1

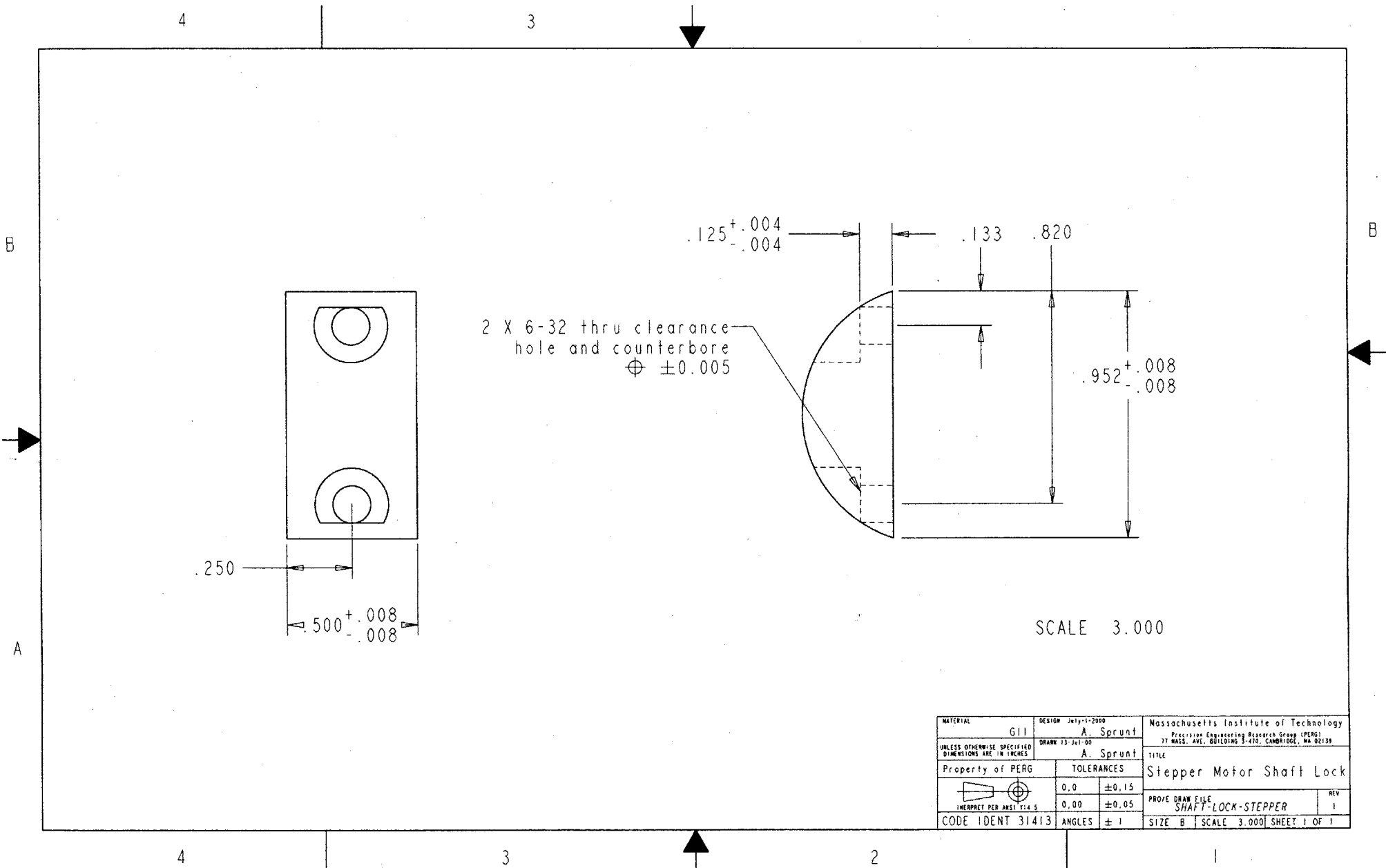

SCALE 3.000

MATERIAL	DESIGN	Massachusetts Institute of Technology	
G11	July-1-2000	Precision Engineering Research Group (PERG)	
UNLESS OTHERWISE SPECIFIED DIMENSIONS ARE IN INCHES	DRAWN	77 MASS. AVE. BUILDING 3-410, CAMBRIDGE, MA 02139	
Property of PERG	13-Jul-00	TITLE	
	A. Sprunt	Stepper Motor Shaft Lock	
	A. Sprunt	PROFE DRAW FILE	REV
		SHAFT-LOCK-STEPPER	1
CODE IDENT 31413	ANGLES ± 1	SIZE B	SCALE 3.000 SHEET 1 OF 1

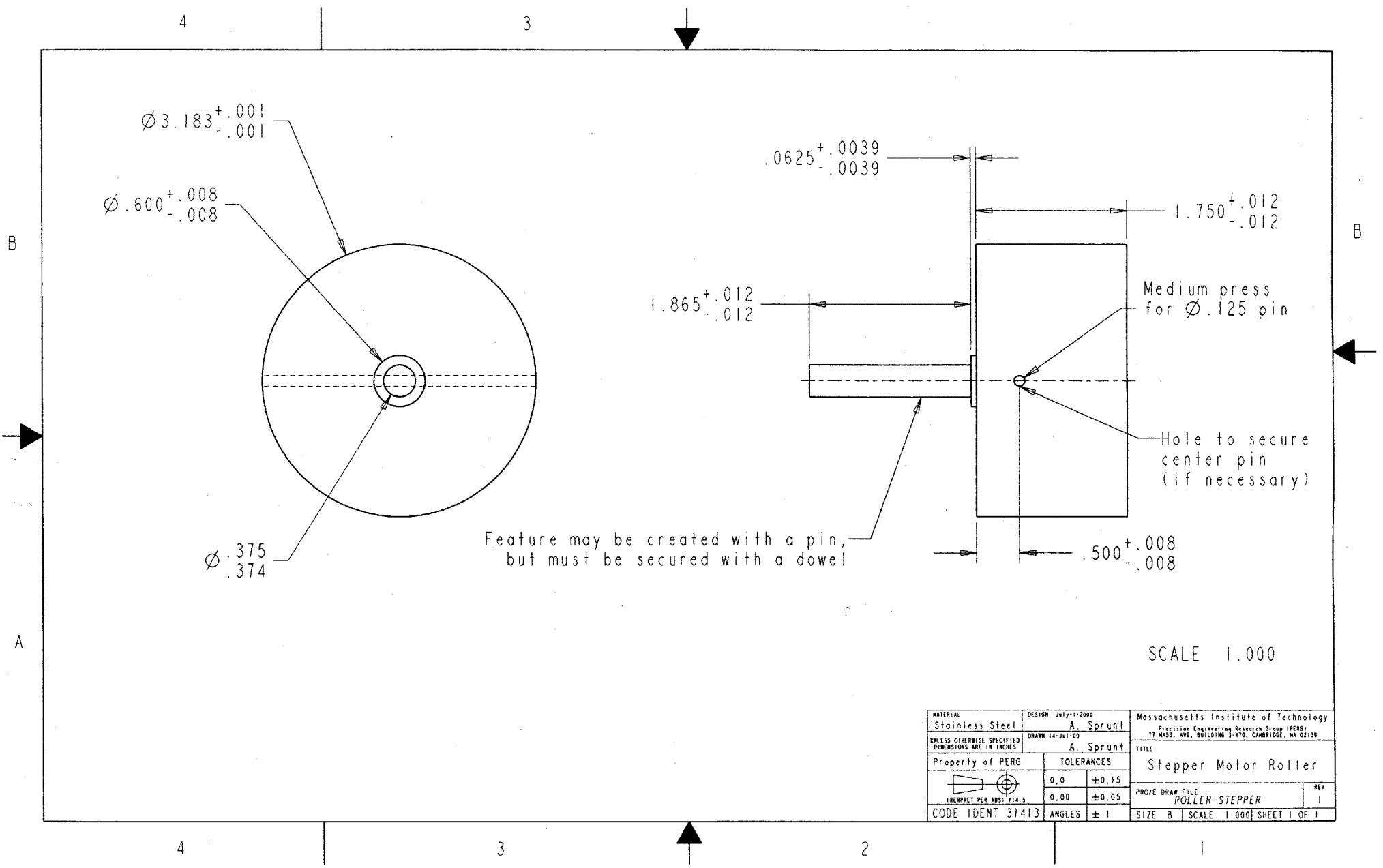

SCALE 1.000

MATERIAL Stainless Steel	DESIGN July-11-2000 A. Sprunt	Massachusetts Institute of Technology Precision Engineering Research Group (PERG) 17 MASS. AVE. BUILDING 3-470, CAMBRIDGE, MA 02139
UNLESS OTHERWISE SPECIFIED DIMENSIONS ARE IN INCHES	DRAWN 14-JUL-00 A. Sprunt	TITLE Stepper Motor Roller
Property of PERG	TOLERANCES	PROJE DRAW FILE ROLLER-STEPPER
	0.0 ±0.15	REV 1
INTERPRET PER ANSI Y14.5	0.00 ±0.05	SIZE B SCALE 1.000 SHEET 1 OF 1
CODE IDENT 31413	ANGLES ± 1	

4

3



PINCH ROLLER (PRT)

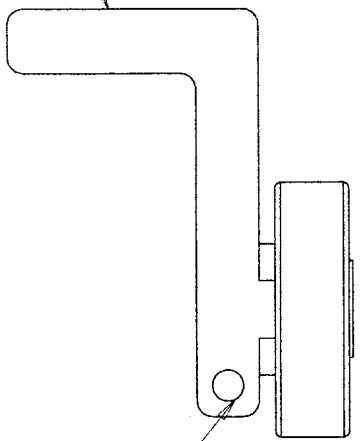

Ø0.251 HOLE FOR PIVOT
QUICK RELEASE PIN
MCMaster PN: 92384A037

3/8-16 THREADED THRU HOLE
FOR SPRING COMPRESSION
ADJUSTING SET SCREW

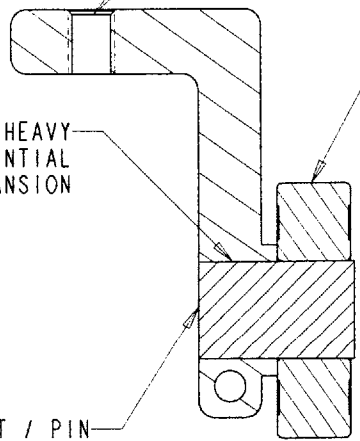

THE PRESS IS HEAVY
TO ACCOMODATE DIFFERENTIAL
THERMAL EXPANSION

SPHERICAL ROLLER
BEARING, SKF
PN: 21304CC

SHAFT / PIN
Ø20 mm NOMINAL K5

SECTION A-A

B

B



A

4

3



2

1

MACH. HOLE TOL.		TOLERANCE		MATERIAL	DESIGN	Feb-15-2001	Massachusetts Institute of Technology Precision Engineering Research Group (PERG) 77 Mass. Ave. Building 3-47B, Cambridge, MA 02139		
.0035 TO .185	+ .003	.X	± .030	NA	DRAWN	Feb-26-2001	TITLE		
	- .002	.XX	± .010				PINCH-ROLLER-ARM		
.1875 TO .246	+ .004	.XXX	± .005	NONE	A. Sprunt	A. Sprunt	Proj# MODEL FILE		
	- .002	ANGLES	± .5°				PINCH-ROLLER-ARM		
.250 TO .750	+ .005		INTERPRET PER ANSI Y14.5	UNLESS OTHERWISE SPECIFIED: 1. DIMENSIONS ARE IN INCHES. 2. ALL DIMENSIONS APPLY AFTER FINISH. 3. REMOVE ALL BURRS & SHARP EDGES. (0.010 MAX. R. OR CHAMFER) 4. MIN. BEND RADIUS. MIN. BEND RELIEF 5. NO TOOL MARKS. 6. MACHINED FINISH: EXCEPT FOR HORIZONTAL MILLING.				MODEL REV	
	- .002							PINCH-ROLLER-ARM	
.765 TO 1.000	+ .007	INTERPRET PER ANSI Y14.5						Proj# DRAWING FILE	
	- .002							PINCH-ROLLER-ARM-ASM	
						SIZE B		SCALE 1.000	
								SHEET 1 OF 1	

4

3

0.25
 $\varnothing 0.251^{+0.002}_{-0.000}$

R0.125^{+0.010}_{-0.010}

$\varnothing 0.7862$ for press
 $\varnothing 0.7857$
of $\varnothing 0.7876$ [20 mm]
K5 shaft

2.50

0.50

0.50

1.50

A

A

$\varnothing 1.06$

0.250

0.611

0.130

SECTION A-A

B

B

A

$\varnothing 0.3125$ (DRILL 5/16)
3/8-16 UNC-2B FULL
THREAD THRU

0.950^{+0.000}_{-0.005}

4

3

2

1

MACH. HOLE TOL.		TOLERANCE		MATERIAL	DESIGN	Massachusetts Institute of Technology		
.0035 TO .185	+ .003 - .002	.X XX	$\pm .030$ $\pm .010$	304 STAINLESS	Feb-12-2001	Precision Engineering Research Group (PERG) 77 Mass. Ave. Building 3-216, Cambridge, MA 02139		
.1875 TO .246	+ .004 - .002	.XXX	$\pm .005$	NONE	Feb-19-2001	TITLE		
.250 TO .750	+ .005 - .002	ANGLES	$\pm .5^\circ$	UNLESS OTHERWISE SPECIFIED	A. Sprunt	PINCH-ROLLER-ARM		
.765 TO 1.000	+ .007 - .002	INTERPRET PER ANSI Y14.5		1. DIMENSIONS ARE IN INCHES. 2. ALL DIMENSIONS APPLY AFTER FINISH. 3. REMOVE ALL BURRS & SHARP EDGES. 4. MIN. BEND RADIUS. MIN. BEND RELIEF. 5. NO TOOL MARKS. 6. MACHINED FINISH: ψ EXCEPT ψ FOR HORIZONTAL MILLING.	PROJECT MODEL FILE		MODEL REV	
						PINCH-ROLLER-ARM		1
						PROJECT DRAWING FILE		DRAW REV
						PINCH-ROLLER-ARM		1
						SIZE B SCALE 1.000		SHEET 1 OF 1



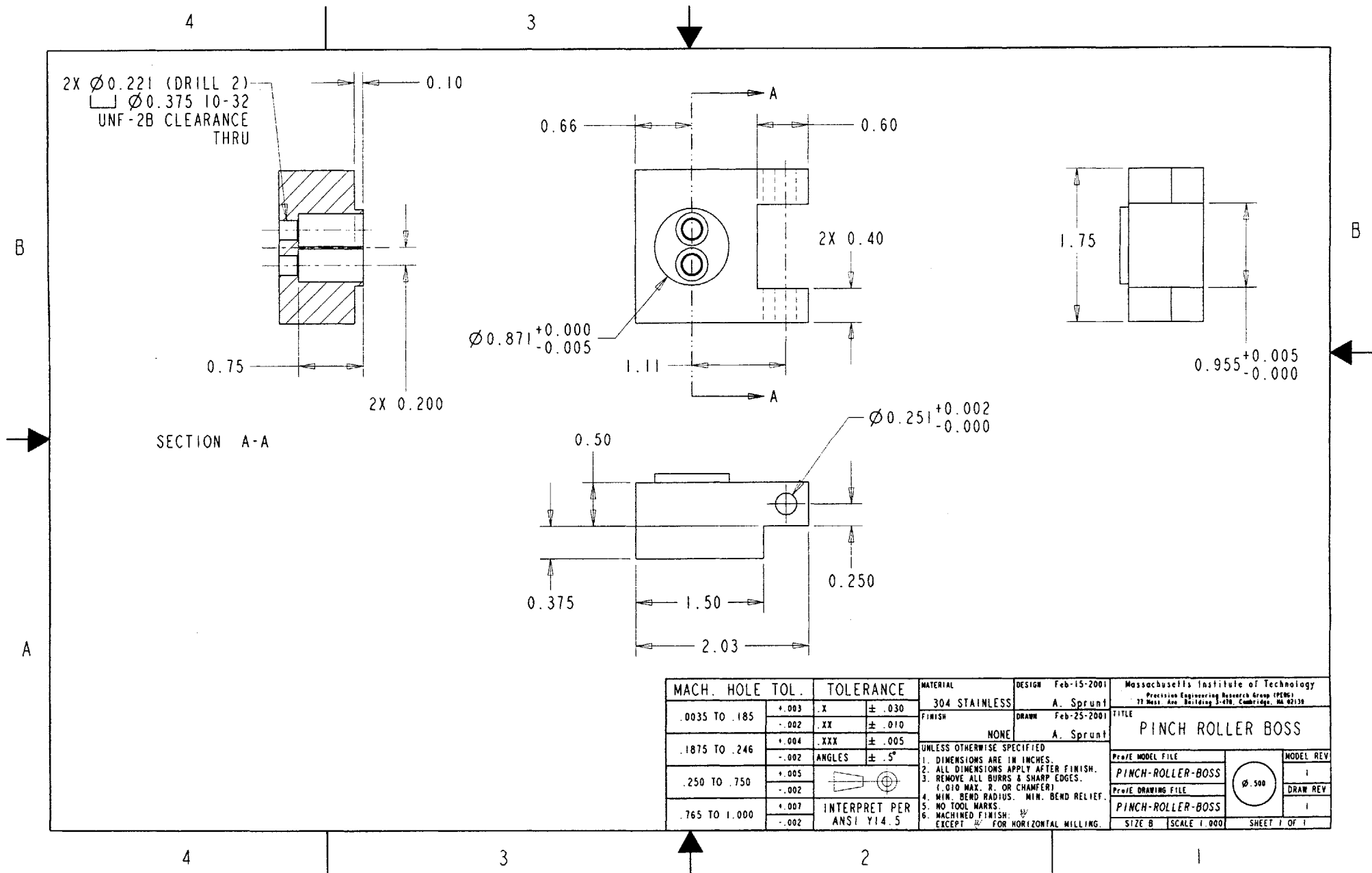

MACH. HOLE TOL.	TOLERANCE	MATERIAL	DESIGN	Massachusetts Institute of Technology Precision Engineering Research Group (PERG) 77 Mass. Ave. Building 3-670, Cambridge, MA 02139
.0035 TO .185	+ .003 - .002	304 STAINLESS	Feb-15-2001	A. Sprunt
.1875 TO .246	+ .004 - .002		Feb-25-2001	
.250 TO .750	+ .005 - .002	UNLESS OTHERWISE SPECIFIED: 1. DIMENSIONS ARE IN INCHES. 2. ALL DIMENSIONS APPLY AFTER FINISH. 3. REMOVE ALL BURRS & SHARP EDGES. (.010 MAX. R. OR CHAMFER) 4. MIN. BEND RADIUS. MIN. BEND RELIEF. 5. NO TOOL MARKS. 6. MACHINED FINISH: ψ EXCEPT ψ FOR HORIZONTAL MILLING.	NONE	
.765 TO 1.000	+ .007 - .002		A. Sprunt	
INTERPRET PER ANSI Y14.5			TITLE PINCH ROLLER BOSS	
			PROFE MODEL FILE	MODEL REV
			PINCH-ROLLER-BOSS	1
			PROFE DRAWING FILE	DRAW REV
			PINCH-ROLLER-BOSS	1
			SIZE B	SCALE 1.000
			SHEET 1 OF 1	

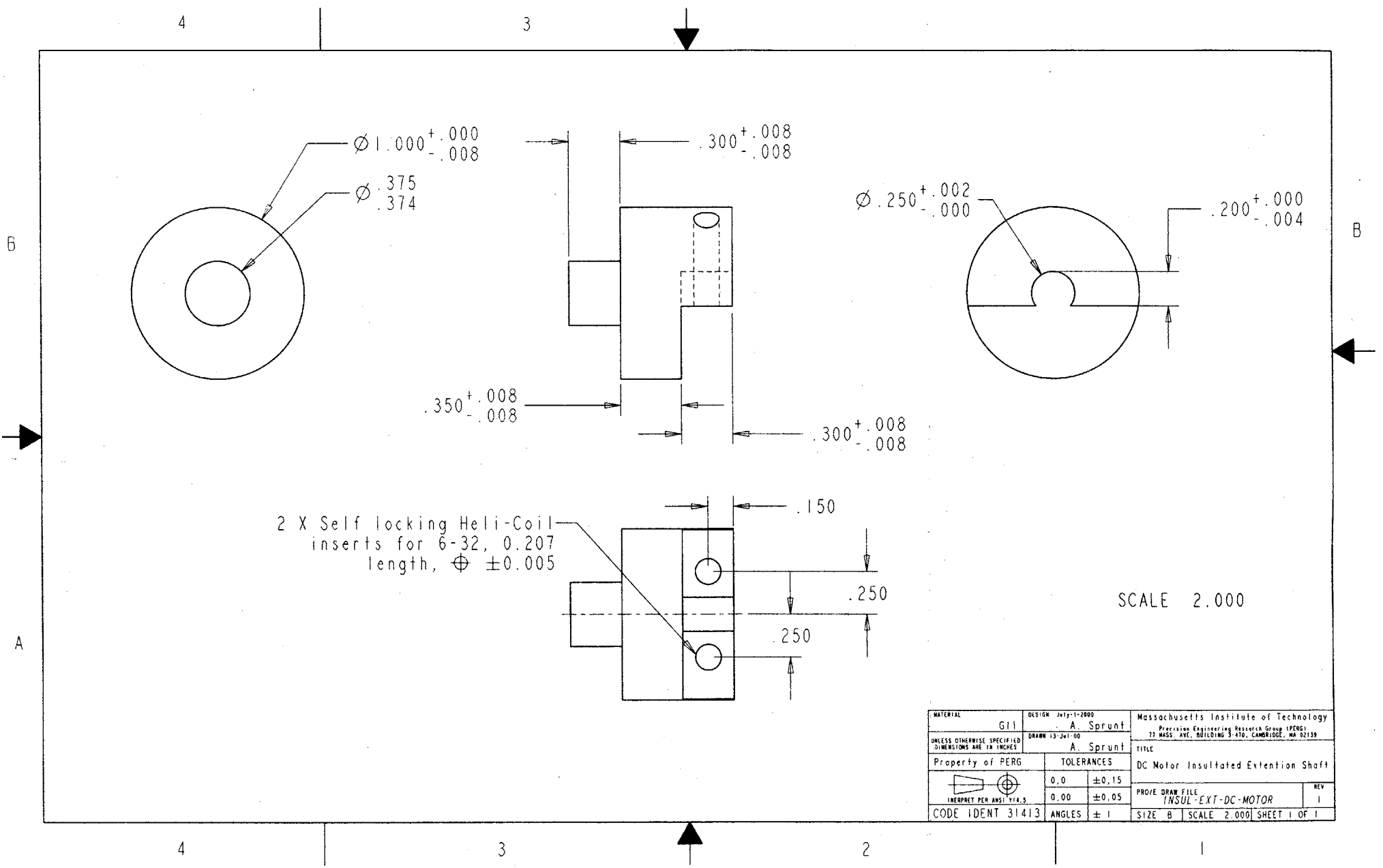

2 X Self locking Heli-Coil
inserts for 6-32, 0.207
length, $\varnothing \pm 0.005$

SCALE 2.000

MATERIAL	DESIGN July-11-2000	Massachusetts Institute of Technology	
G11	A. Sprunt	Precision Engineering Research Group (PERG) 77 MASS. AVE. BUILDING 3-430, CAMBRIDGE, MA 02139	
UNLESS OTHERWISE SPECIFIED DIMENSIONS ARE IN INCHES	DRAWN 13-JUL-00	TITLE	
Property of PERG	A. Sprunt	DC Motor Insulated Extension Shaft	
 INSPECT PER ANSI Y14.5	TOLERANCES		PROJE DRAW FILE INSUL-EXT-DC-MOTOR
	0.0	± 0.15	
0.00	± 0.05	1	1
CODE IDENT 31413	ANGLES ± 1	SIZE B	SCALE 2.000 SHEET 1 OF 1

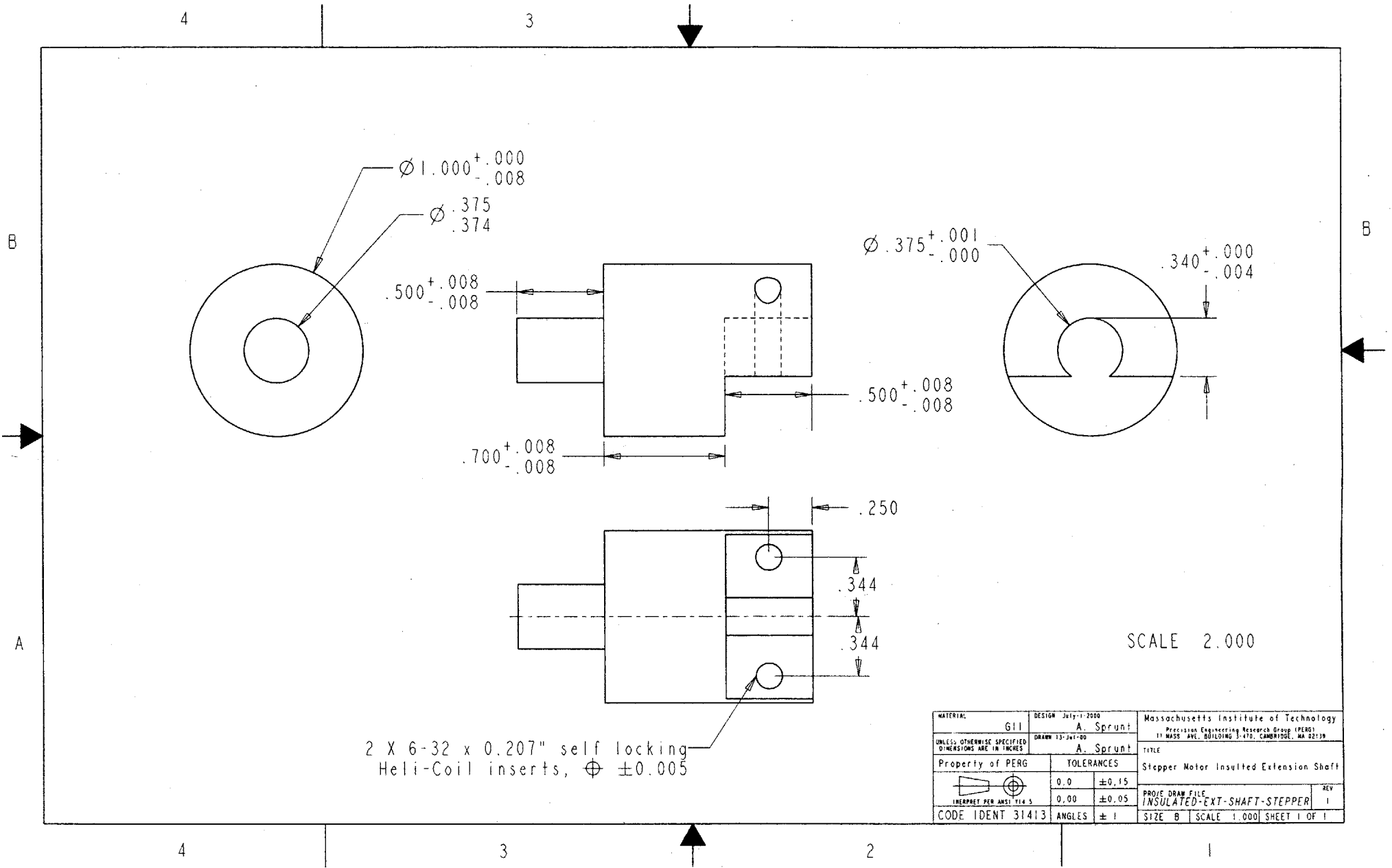

MATERIAL	DESIGN July-11-2000	Massachusetts Institute of Technology
Gil	A. Sprunt	Precision Engineering Research Group (PERG)
UNLESS OTHERWISE SPECIFIED DIMENSIONS ARE IN INCHES	DRAWN 13-JUL-00	37 MASS. AVE., BUILDING 3-470, CAMBRIDGE, MA 02139
Property of PERG	A. Sprunt	TITLE
		Stepper Motor Insulated Extension Shaft
	TOLERANCES	PROJ. DRAW FILE
	0.0 ±0.15	INSULATED-EXT-SHAFT-STEPPER
	0.00 ±0.05	REV
CODE IDENT 31413	ANGLES ± 1	1
	SIZE B	SCALE 1.000 SHEET 1 OF 1

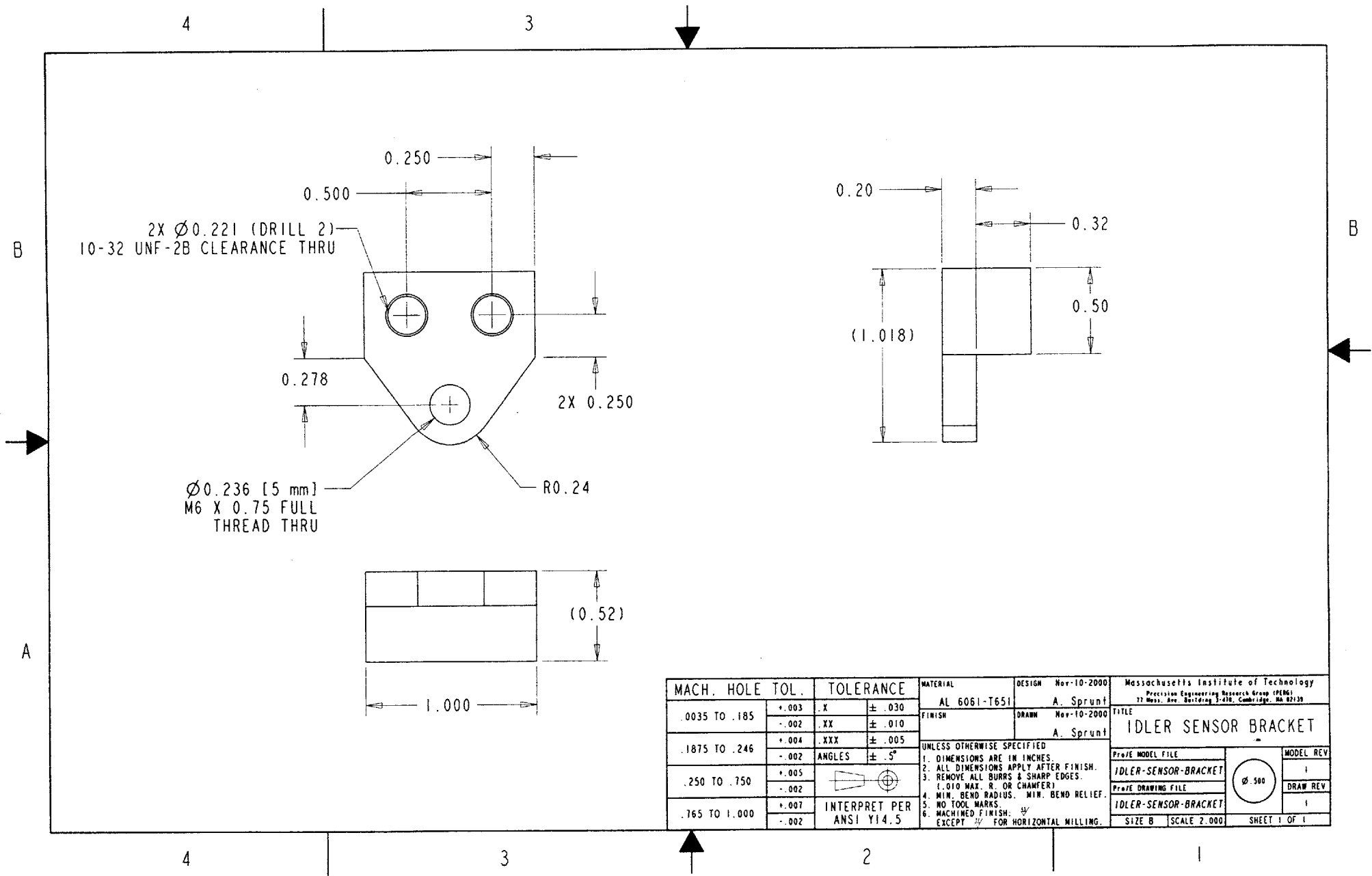

MACH. HOLE TOL.	TOLERANCE	MATERIAL	DESIGN	Nov-10-2000	Massachusetts Institute of Technology		
0035 TO .185	+ .003 .X ± .030	AL 6061-T651	A. Sprunt		Precision Engineering Research Group (PERG)		
	- .002 .XX ± .010				77 Mass. Ave. Building 3-410, Cambridge, MA 02139		
.1875 TO .246	+ .004 .XXX ± .005		FINISH	Nov-10-2000	TITLE		
	- .002 ANGLES ± .5°			A. Sprunt	IDLER SENSOR BRACKET		
.250 TO .750	+ .005	UNLESS OTHERWISE SPECIFIED 1. DIMENSIONS ARE IN INCHES. 2. ALL DIMENSIONS APPLY AFTER FINISH. 3. REMOVE ALL BURRS & SHARP EDGES. (.010 MAX. R. OR CHAMFER) 4. MIN. BEND RADIUS. MIN. BEND RELIEF. 5. NO TOOL MARKS. 6. MACHINED FINISH: $\sqrt{\text{W}}$ EXCEPT $\sqrt{\text{W}}$ FOR HORIZONTAL MILLING.			PROJ MODEL FILE	MODEL REV	
	- .002				IDLER-SENSOR-BRACKET	1	
.765 TO 1.000	+ .007 INTERPRET PER ANSI Y14.5				PROJ DRAWING FILE	DRAW REV	
	- .002				IDLER-SENSOR-BRACKET	1	
					SIZE B	SCALE 2.000	SHEET 1 OF 1

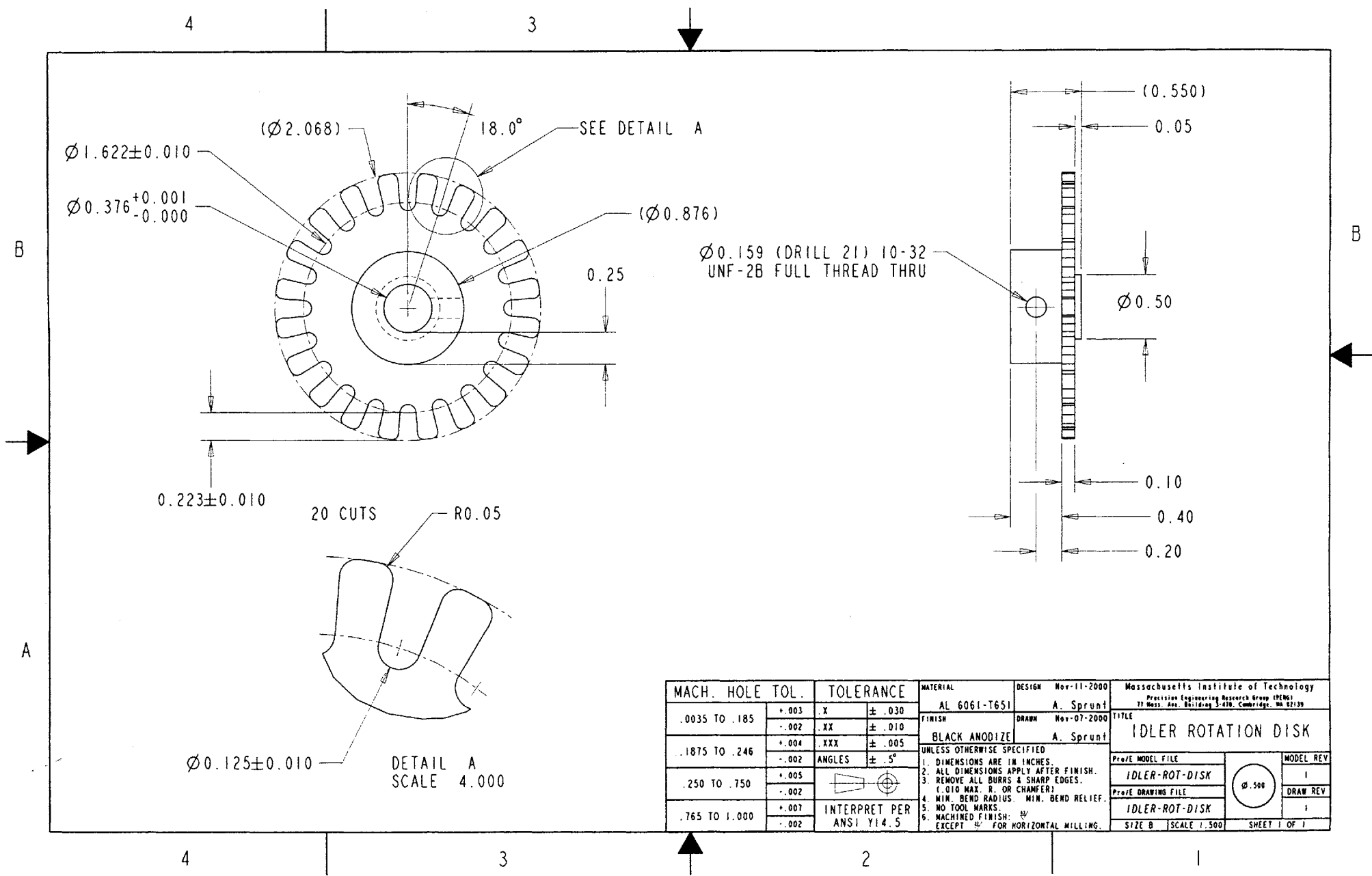

MACH. HOLE TOL.	TOLERANCE	MATERIAL	DESIGN	Massachusetts Institute of Technology
.0035 TO .185	$\pm .003$ X $\pm .030$	AL 6061-T651	Nov-11-2000	Precision Engineering Research Group (PERG) 77 Mass. Ave. Building 3-470, Cambridge, MA 02139
.1875 TO .246	$\pm .002$ XX $\pm .010$	FINISH	Nov-07-2000	TITLE
.250 TO .750	$\pm .004$ XXX $\pm .005$	BLACK ANODIZE	A. Sprunt	IDLER ROTATION DISK
.765 TO 1.000	$\pm .002$ ANGLES $\pm .5^\circ$	UNLESS OTHERWISE SPECIFIED	A. Sprunt	PROJ. MODEL FILE
	$\pm .005$	1. DIMENSIONS ARE IN INCHES.		IDLER-ROT-DISK
	$\pm .002$	2. ALL DIMENSIONS APPLY AFTER FINISH.		PROJ. DRAWING FILE
	$\pm .007$	3. REMOVE ALL BURRS & SHARP EDGES.		IDLER-ROT-DISK
	$\pm .002$	4. (.010 MAX. R. OR CHAMFER)		SIZE B SCALE 1:500
	INTERPRET PER ANSI Y14.5	5. MIN. BEND RADIUS. MIN. BEND RELIEF.		MODEL REV
		6. MACHINED FINISH: $\sqrt{\text{V}}$		1
		EXCEPT $\sqrt{\text{H}}$ FOR HORIZONTAL MILLING.		DRAW REV
				1
				SHEET 1 OF 1

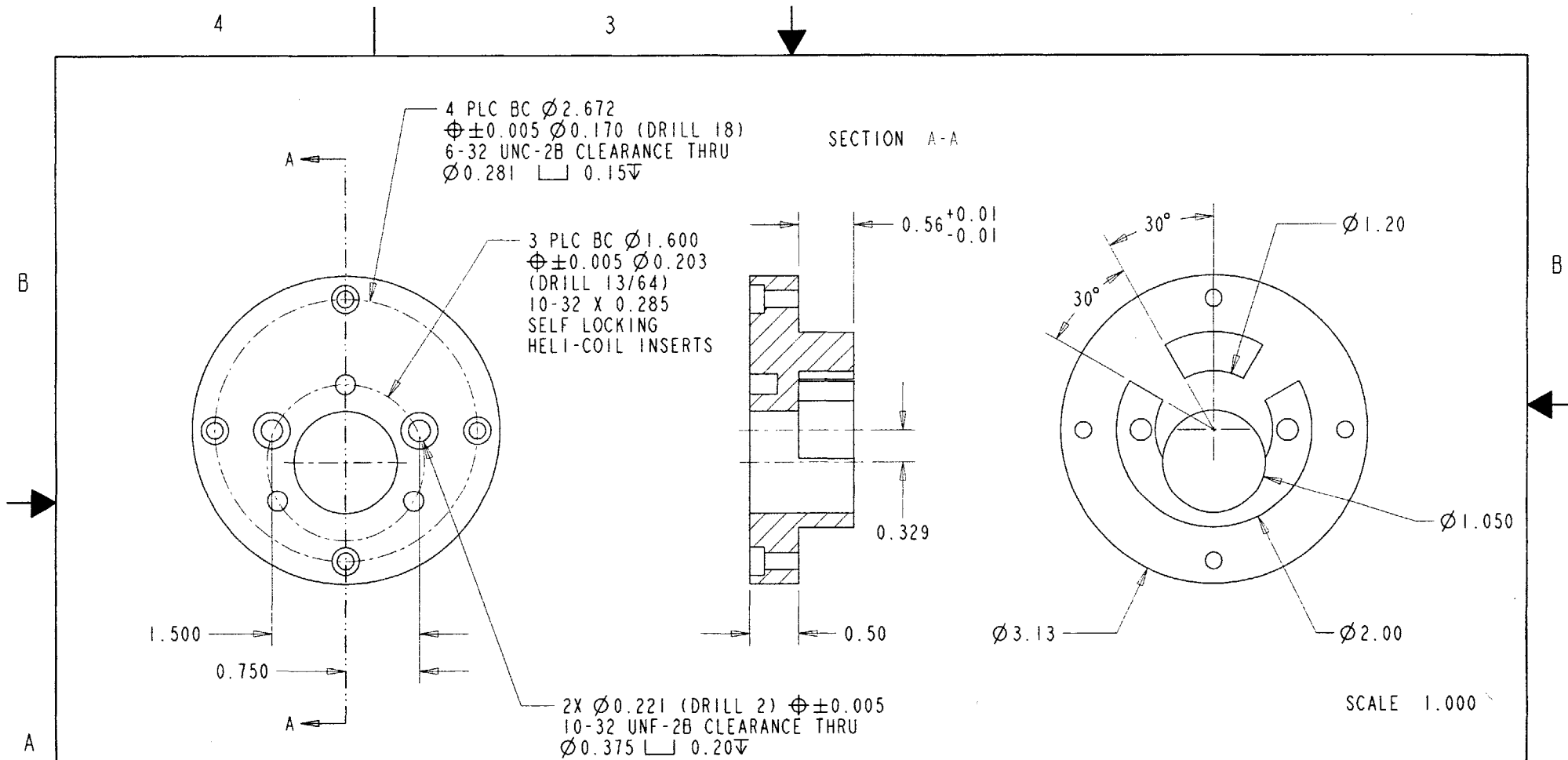

MACH. HOLE TOL.	TOLERANCE	MATERIAL	DESIGN	Massachusetts Institute of Technology Precision Engineering Research Group (PERG) 77 Mass. Ave. Building 3-420, Cambridge, MA 02139
.0035 TO .185	+ .003 - .002 XX ± .030 ± .010	G11	July-1-2000 A. Sprunt	TITLE DC Motor End Plug
.1875 TO .246	+ .004 - .002 XXX ± .005 ± .5°		Oct-16-2000 A. Sprunt	
.250 TO .750	+ .005 - .002	UNLESS OTHERWISE SPECIFIED 1. DIMENSIONS ARE IN INCHES. 2. ALL DIMENSIONS APPLY AFTER FINISH. 3. REMOVE ALL BURRS & SHARP EDGES. (.010 MAX. R. OR CHAMFER) 4. MIN. BEND RADIUS. MIN. BEND RELIEF. 5. NO TOOL MARKS. 6. MACHINED FINISH: ∇		PROFE MODEL FILE END-PLUG-DC-MOTOR
.765 TO 1.000	+ .007 - .002 INTERPRET PER ANSI Y14.5	EXCEPT ∇ FOR HORIZONTAL MILLING.		PROFE DRAWING FILE END-PLUG-DC-MOTOR
				SIZE B SCALE 1.000
				MODEL REV 1 DRAW REV 2
				$\varnothing .500$ SHEET 1 OF 1

4 3 2 1

4

3



4 X 10-32 x 0.285
self locking Heli-
Coil inserts

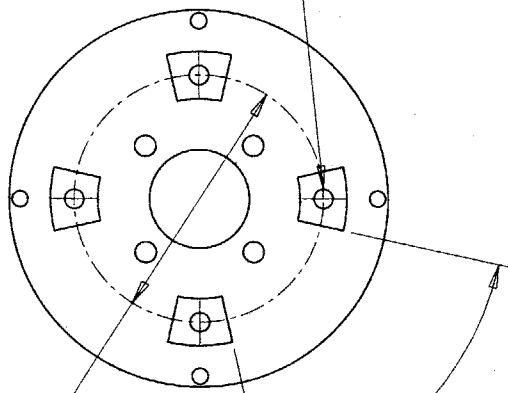

$65.000^{\circ} \pm 1.000^{\circ}$
 -1.000°

4 Plc BC $\varnothing 2.625$
 $\oplus \pm 0.005$

$\varnothing 2.125^{+0.012}$
 -0.012

$\varnothing 3.125^{+0.012}$
 -0.012

4 Plc BC $\varnothing 3.774$
 $\oplus \pm 0.005$

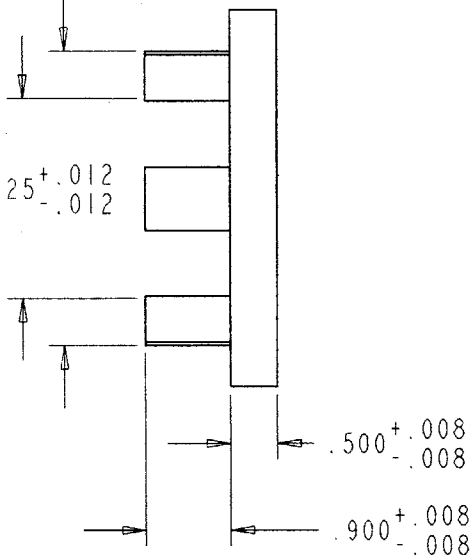

$.500^{+0.008}$
 -0.008

$.900^{+0.008}$
 -0.008

4 X 10-32
clearance hole

$\varnothing 4.000^{+0.012}$
 -0.012

$\varnothing 1.050^{+0.008}$
 -0.000

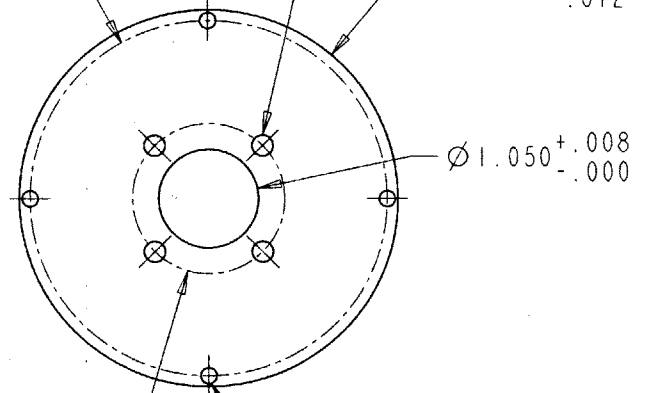

4 X 6-32 clearance hole

4 Plc BC $\varnothing 1.600$
 $\oplus \pm 0.005$

SCALE 0.750

MATERIAL	DESIGN July-1-2000	Massachusetts Institute of Technology	
Gil	A Sprunt	Precision Engineering Research Group (PERG)	
UNLESS OTHERWISE SPECIFIED DIMENSIONS ARE IN INCHES	DRAWN 13-JUL-00	77 MASS. AVE. BUILDING 3-670, CAMBRIDGE, MA 02139	
Property of PERG	A Sprunt	TITLE	
TOLERANCES		Stepper Motor Shell End Plug	
	0.0 ±0.15	PROJ/ DRAW FILE	REV
	0.00 ±0.05	END-PLUG-STEPPER	1
CODE IDENT 31413	ANGLES ± 1	SIZE B	SCALE 1:000 SHEET 1 OF 1

4

3



2

1

B

B

A



4

3



SECTION B-B

B

B

SECTION A-A

$\varnothing 1.200^{+.012}_{-.012}$

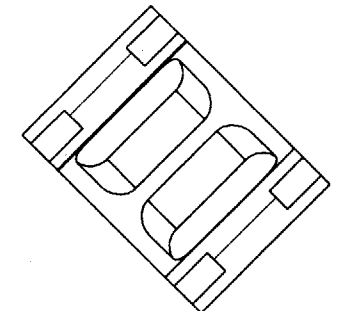
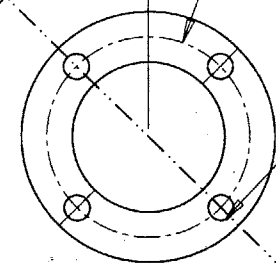
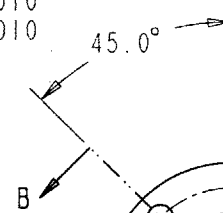
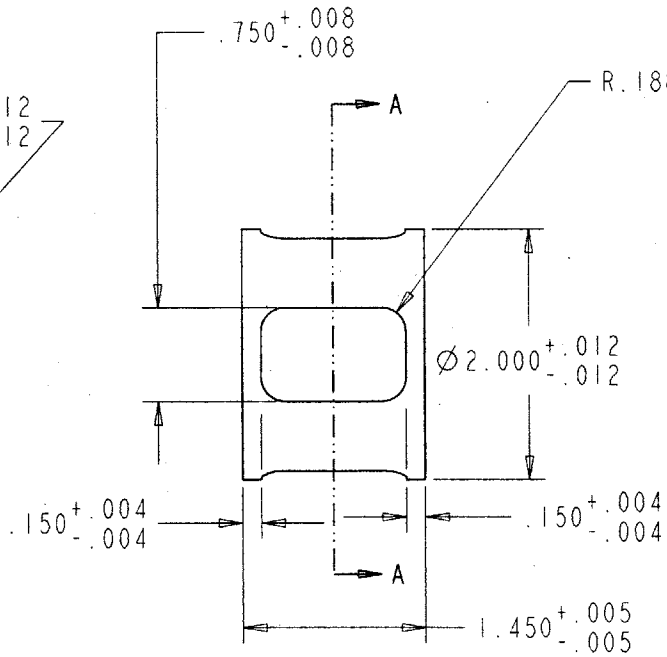
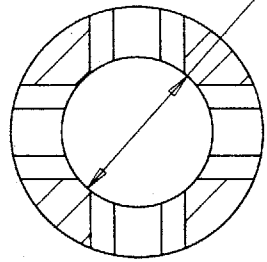

4 Plc BC $\varnothing 1.600 \pm 0.005$

Self locking Heli-Coil inserts for 10-32, 0.285" length X 8 on both sides

A

MATERIAL	DESIGN July-1-2000	Massachusetts Institute of Technology	
G11	A. Sprunt	Precision Engineering Research Group (PERG) 27 MASS. AVE. BUILDING 3-410, CAMBRIDGE, MA 02139	
UNLESS OTHERWISE SPECIFIED DIMENSIONS ARE IN INCHES	DRAWN 12-JUL-00	TITLE	
Property of PERG	A. Sprunt	Stepper Motor Spacer	
	TOLERANCES	REV	
	0,0 ±0.15	PROOF DRAW FILE	1
INTERPRET PER ANSI Y14.5	0,00 ±0.05	FLEX-COUP-L-SPACER-STEPPER	
CODE IDENT 31413	ANGLES ± 1	SIZE B	SCALE 1.000 SHEET 1 OF 1

4

3



2

1

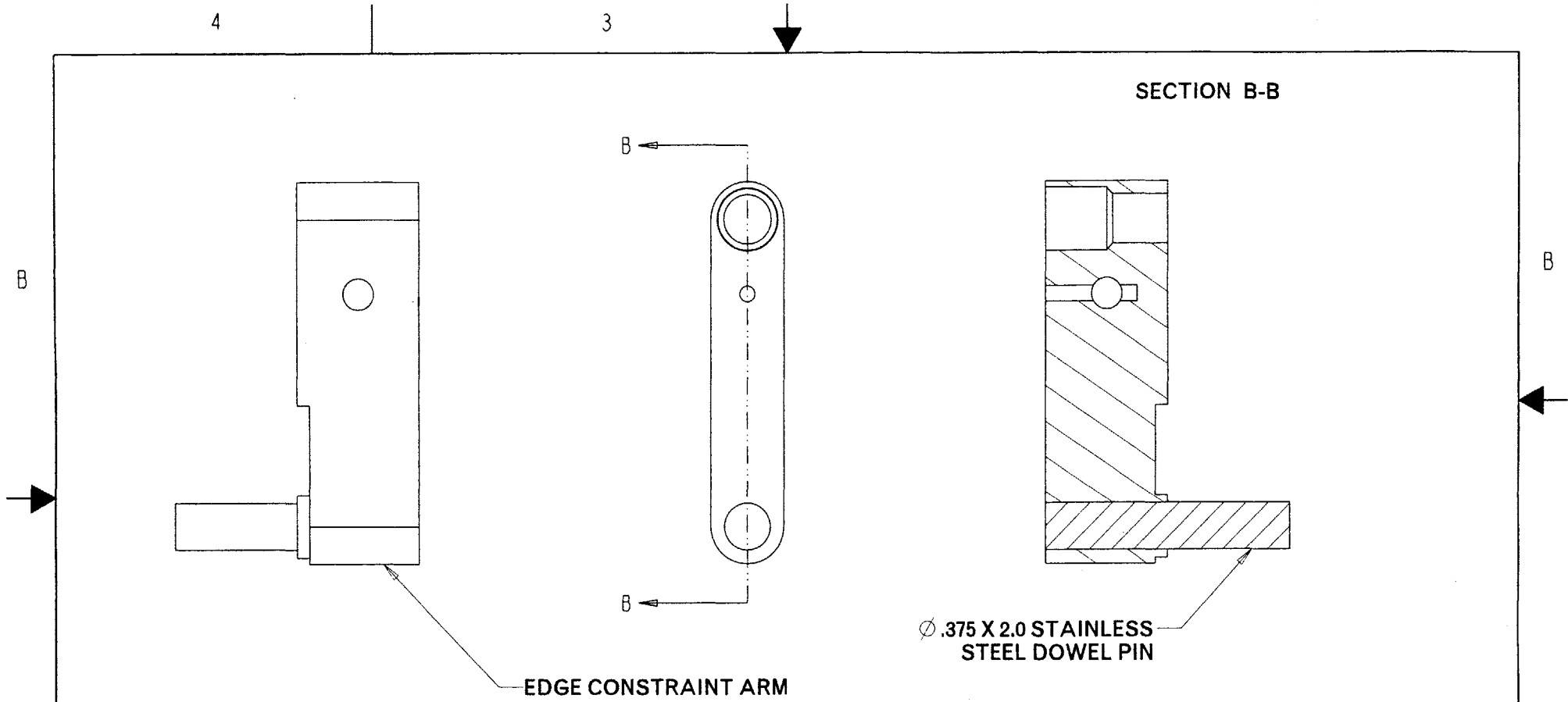

EDGE CONSTRAINT ARM

Ø.375 X 2.0 STAINLESS
STEEL DOWEL PIN

SCALE 1.250

MACH. HOLE TOL.		TOLERANCE		MATERIAL	DESIGN	AUG-1-2000	Massachusetts Institute of Technology Precision Engineering Research Group (PERG) 77 Mass. Ave. Building 5-470, Cambridge, MA 02139	
.0035 TO .185	+ .003 - .002	.X .XX	± .030 ± .010	N/A	A. Sprunt		TITLE	
.1875 TO .246	+ .004 - .002	.XXX	± .005	N/A	A. Sprunt	DRAWN	08-Sep-00	EDGE CONSTRAINT ARM ASSEMBLY
.250 TO .750	+ .005 - .002	ANGLES	± .5	UNLESS OTHERWISE SPECIFIED				
.785 TO 1.000	+ .007 - .002	INTERPRET PER ANSI Y14.5		1. DIMENSIONS ARE IN INCHES. 2. ALL DIMENSIONS APPLY AFTER FINISH. 3. REMOVE ALL BURRS & SHARP EDGES. (.010 MAX. R. OR CHAMFER) 4. MIN. BEND RADIUS. MIN. BEND RELIEF. NO TOOL MARKS. 5. MACHINED FINISH: \forall 6. EXCEPT \forall FOR HORIZONTAL MILLING.				
							Pro/E MODEL FILE	MODEL REV
							EDGE CONSTRAINT-ARM-ASM	1
							Pro/E DRAWING FILE	DRAW REV
							EDGE CONSTRAINT-ARM-ASM	1
							SIZE B	SHEET 1 OF 1



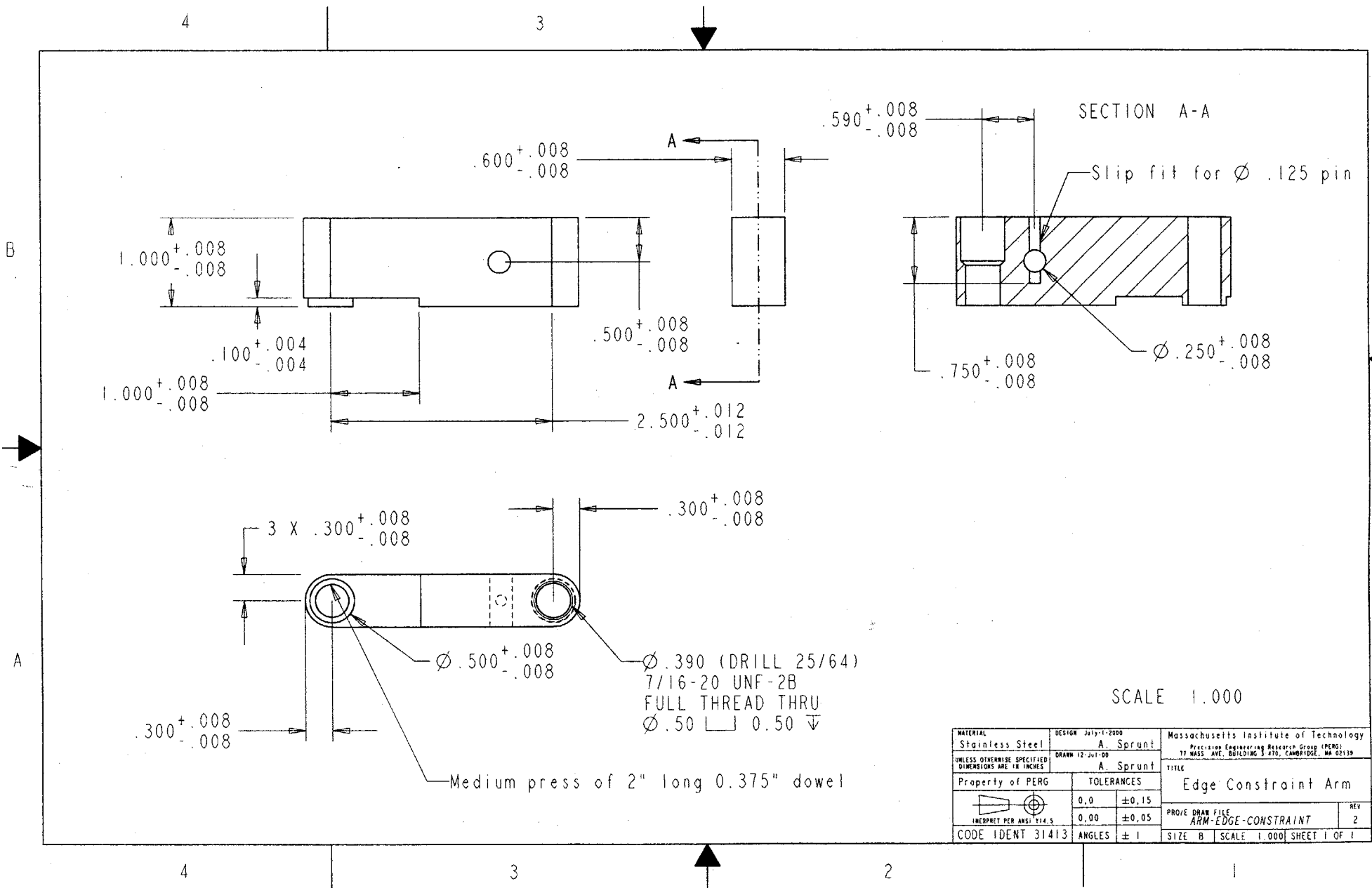

MATERIAL Stainless Steel	DESIGN July-1-2000 A. Sprunt	Massachusetts Institute of Technology Precision Engineering Research Group (PERG) 37 MASS. AVE. BUILDING 3 470, CAMBRIDGE, MA 02139
UNLESS OTHERWISE SPECIFIED DIMENSIONS ARE IN INCHES	DRAWN 12-Jul-00 A. Sprunt	TITLE Edge Constraint Arm
PROPERTY OF PERG	TOLERANCES	PROJ/ DRAW FILE ARM-EDGE-CONSTRAINT
	0.0 ±0.15	REV 2
	0.00 ±0.05	SIZE B SCALE 1.000 SHEET 1 OF 1
CODE IDENT 31413	ANGLES ± 1	

4

3

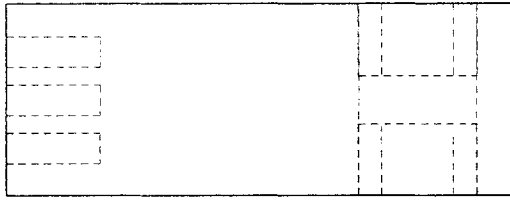

EDGE CONSTRAINT BRACKET

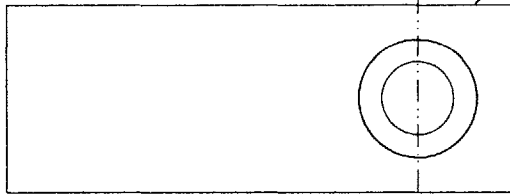

A

A

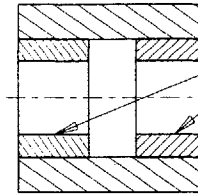

GRAPHALLY BUSHINGS
PART NUMBER: 117-6-212

SECTION A-A

B

B

A

SCALE 1.500

MACH. HOLE TOL.		TOLERANCE		MATERIAL	DESIGN	Massachusetts Institute of Technology Precision Engineering Research Group (PERG) 77 Mass. Ave. Building 3-470, Cambridge, MA 02139	
.0035 TO .185	+ .003 - .002	.X	± .030	N/A	AUG-1-2000	A. Sprunt	
.1875 TO .246	+ .004 - .002	.XX	± .010	FINISH	DRAWN 09-Sep-00	TITLE	
.250 TO .750	+ .005 - .002	.XXX	± .005	N/A		A. Sprunt	
.765 TO 1.000	+ .007 - .002	ANGLES	± .5	UNLESS OTHERWISE SPECIFIED			
				1. DIMENSIONS ARE IN INCHES.			
				2. ALL DIMENSIONS APPLY AFTER FINISH.			
				3. REMOVE ALL BURRS & SHARP EDGES. (.010 MAX. R. OR CHAMFER)			
				4. MIN. BEND RADIUS. MIN. BEND RELIEF.			
				5. NO TOOL MARKS.			
				6. MACHINED FINISH: ψ			
				EXCEPT ψ FOR HORIZONTAL MILLING.			
				INTERPRET PER ANSI Y14.5		EDGE CONSTRAINT BRACKET ASSEMBLY	
						ProjE MODEL FILE	MODEL REV
						EDGE CONSTRAINT-BRACKET-ASM	1
						ProjE DRAWING FILE	DRAW REV
						EDGE CONSTRAINT-BRACKET-ASM	1
						SIZE B	SHEET 1 OF 1

4

3



2

1

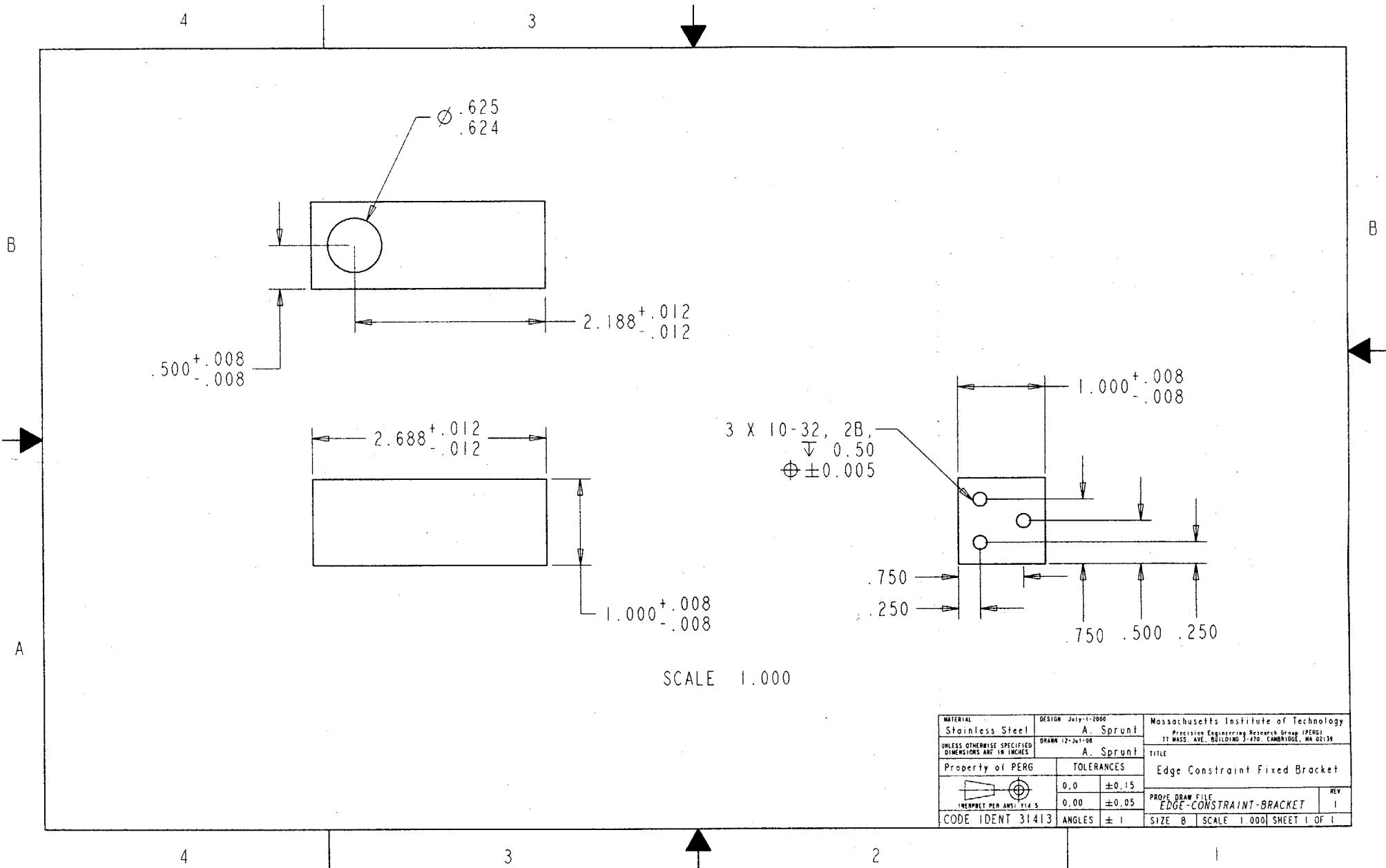

SCALE 1.000

MATERIAL Stainless Steel	DESIGN July 1-2000 A. Sprunt	Massachusetts Institute of Technology Precision Engineering Research Group (PERG) 11 MASS. AVE. BUILDING 3-470 CAMBRIDGE, MA 02139	
UNLESS OTHERWISE SPECIFIED DIMENSIONS ARE IN INCHES	DRAWN 12-JUL-90 A. Sprunt	TITLE Edge Constraint Fixed Bracket	
Property of PERG	TOLERANCES	PROJ. DRAW FILE EDGE-CONSTRAINT-BRACKET	
	0,0 ±0,15	SIZE B	REV 1
INCOMPET PER ANSI Y14.5	0,00 ±0,05	SCALE 1 000 SHEET 1 OF 1	
CODE IDENT 31413	ANGLES ± 1		

4

3



Self locking Heli-Coil
inserts for 10-32,
0.285" length X 3

$\varnothing 2.000^{+.012}_{-.012}$

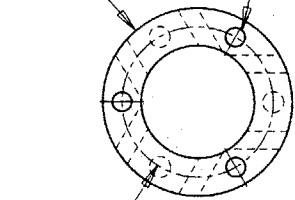

3 Plc BC $\varnothing 1.600 \pm 0.005$

$.150^{+.004}_{-.004}$

A



$R.1875^{+.0100}_{-.0100}$

$1.000^{+.008}_{-.008}$

$1.450^{+.012}_{-.012}$

A

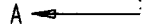

$.250^{+.008}_{-.008}$

SECTION A-A

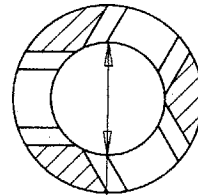

$\varnothing 1.200^{+.012}_{-.012}$

$\varnothing .221^{+.004}_{-.004}$

3 Plc BC $\varnothing 1.600 \pm 0.005$

120.0°

60.0°

Pockets are centered
on holes

B

B

A

4

3



2

1

SCALE 0.750

MATERIAL	DESIGN July 1-2800	Massachusetts Institute of Technology	
G11	A. Sprunt	Precision Engineering Research Group (PERG) 77 MASS. AVE. BUILDING 3-470, CAMBRIDGE, MA 02139	
UNLESS OTHERWISE SPECIFIED DIMENSIONS ARE IN INCHES	DRAWN 12-JUL-60	TITLE	
Property of PERG	A. Sprunt	DC Motor Spacer	
	TOLERANCES	0.0	±0.15
		0.00	±0.05
CODE IDENT 31413	ANGLES ± 1	PROJ. DRAW FILE	REV
		DC-MOTOR-SPACER	1
		SIZE B	SCALE 1.000 SHEET 1 OF 1

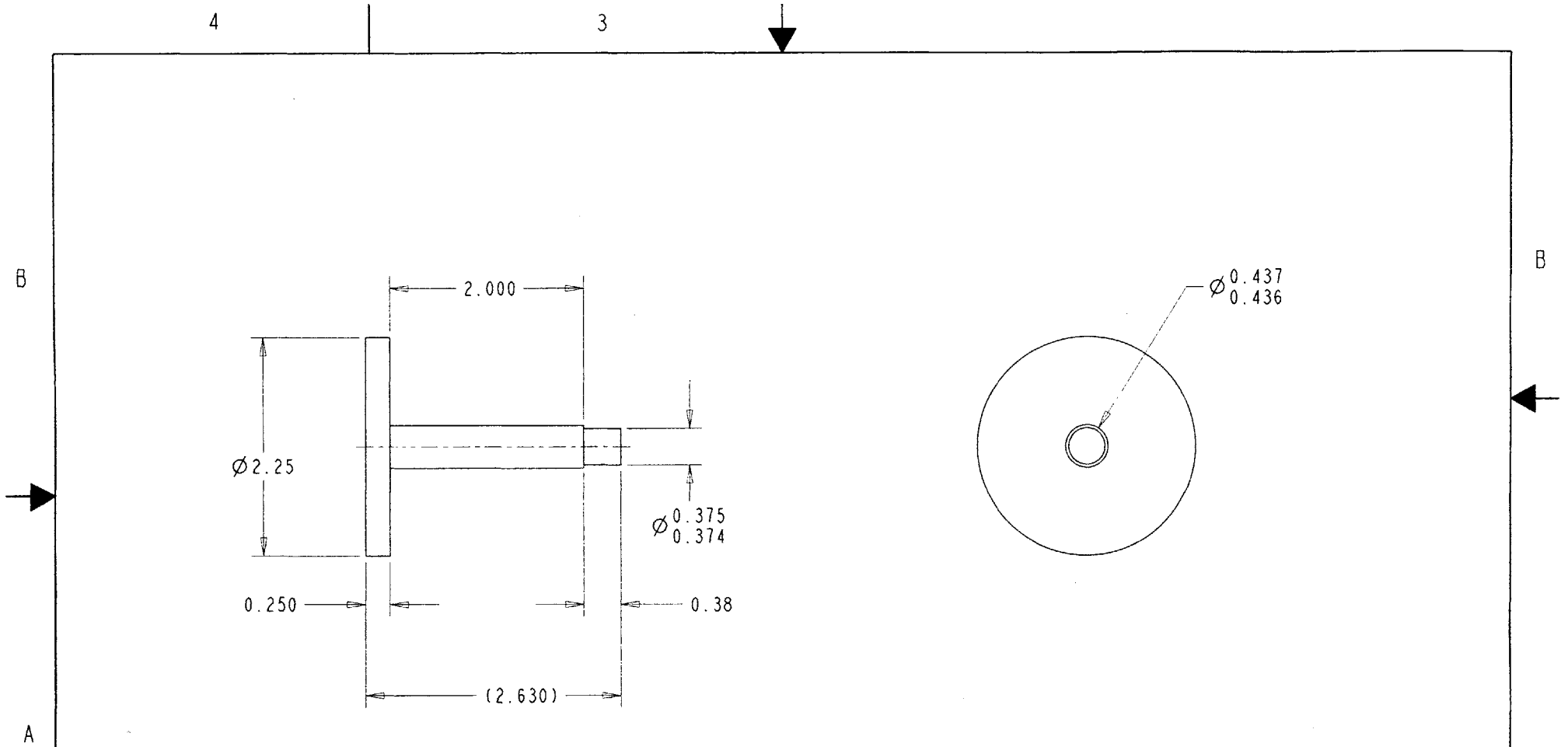

SHAFT MAY BE PRESSED INTO DISK SO LONG AS IT IS SECURED BY A $\varnothing 0.125$ STAINLESS STEEL DOWEL PIN

MACH. HOLE TOL.		TOLERANCE		MATERIAL	DESIGN	Massachusetts Institute of Technology Precision Engineering Research Group (PERG) 77 Mass. Ave. Building 3-070, Cambridge, MA 02138		
.0035 TO .185	+ .003 - .002	.X XX	$\pm .030$ $\pm .010$	304 STAINLESS	Oct-22-2000 A. Sprunt	TITLE		
.1875 TO .246	+ .004 - .002	.XXX ANGLES	$\pm .005$ $\pm .5^\circ$	FINISH	Oct-26-2000 A. Sprunt	STIFF DISK SHAFT		
.250 TO .750	+ .005 - .002			UNLESS OTHERWISE SPECIFIED 1. DIMENSIONS ARE IN INCHES. 2. ALL DIMENSIONS APPLY AFTER FINISH. 3. REMOVE ALL BURRS & SHARP EDGES. (.010 MAX. R. OR CHAMFER) 4. MIN. BEND RADIUS. MIN. BEND RELIEF. 5. NO TOOL MARKS. 6. MACHINED FINISH: ∇ EXCEPT ∇ FOR HORIZONTAL MILLING.			PROE MODEL FILE DISK-SHAFT-STIFF	MODEL REV 1
.765 TO 1.000	+ .007 - .002	INTERPRET PER ANSI Y14.5					PROE DRAWING FILE DISK-SHAFT-STIFF	DRAW REV 1
						SIZE B	SCALE 1.000	SHEET 1 OF 1

4

3

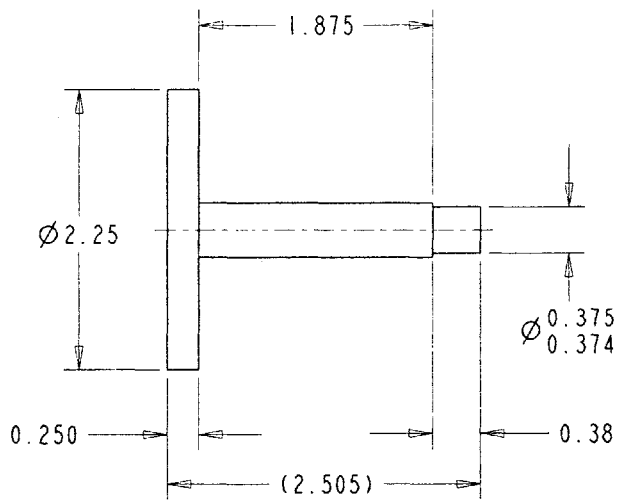
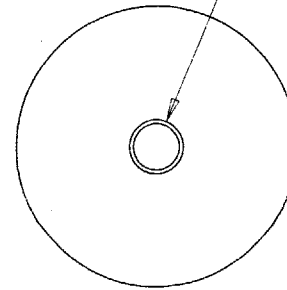

B

 $\varnothing 0.437$
 0.436

B



A

SHAFT MAY BE PRESSED INTO
 DISK SO LONG AS IT IS
 SECURED BY A $\varnothing 0.125$
 STAINLESS STEEL DOWEL PIN

MACH. HOLE TOL.		TOLERANCE		MATERIAL	DESIGN	Massachusetts Institute of Technology
.0035 TO .185	+ .003	X	$\pm .030$	304 STAINLESS	Oct-22-2000	Precision Engineering Research Group (PERG) 77 Mass. Ave. Building 3-470, Cambridge, MA 02139
	- .002	.XX	$\pm .010$		A. Sprunt	
.1875 TO .246	+ .004	.XXX	$\pm .005$	UNLESS OTHERWISE SPECIFIED	Oct-26-2000	TITLE
	- .002	ANGLES	$\pm .5^\circ$		A. Sprunt	
.250 TO .750	+ .005		$\pm .010$	1. DIMENSIONS ARE IN INCHES. 2. ALL DIMENSIONS APPLY AFTER FINISH. 3. REMOVE ALL BURRS & SHARP EDGES. 4. .010 MAX. R. OR CHAMFER) 5. MIN. BEND RADIUS. MIN. BEND RELIEF. 6. MACHINED FINISH: \forall EXCEPT \forall FOR HORIZONTAL MILLING.	DRAWN	Pro/E MODEL FILE
	- .002					
.765 TO 1.000	+ .007	INTERPRET PER ANSI Y14.5	$\pm .010$	FINISH	DRAWN	Pro/E DRAWING FILE
	- .002					

DISK SHAFT

$\varnothing .500$	MODEL REV
	1
	DRAW REV
	1
SIZE B	SCALE 1:000
SHEET 1 OF 1	

4

3



2

1

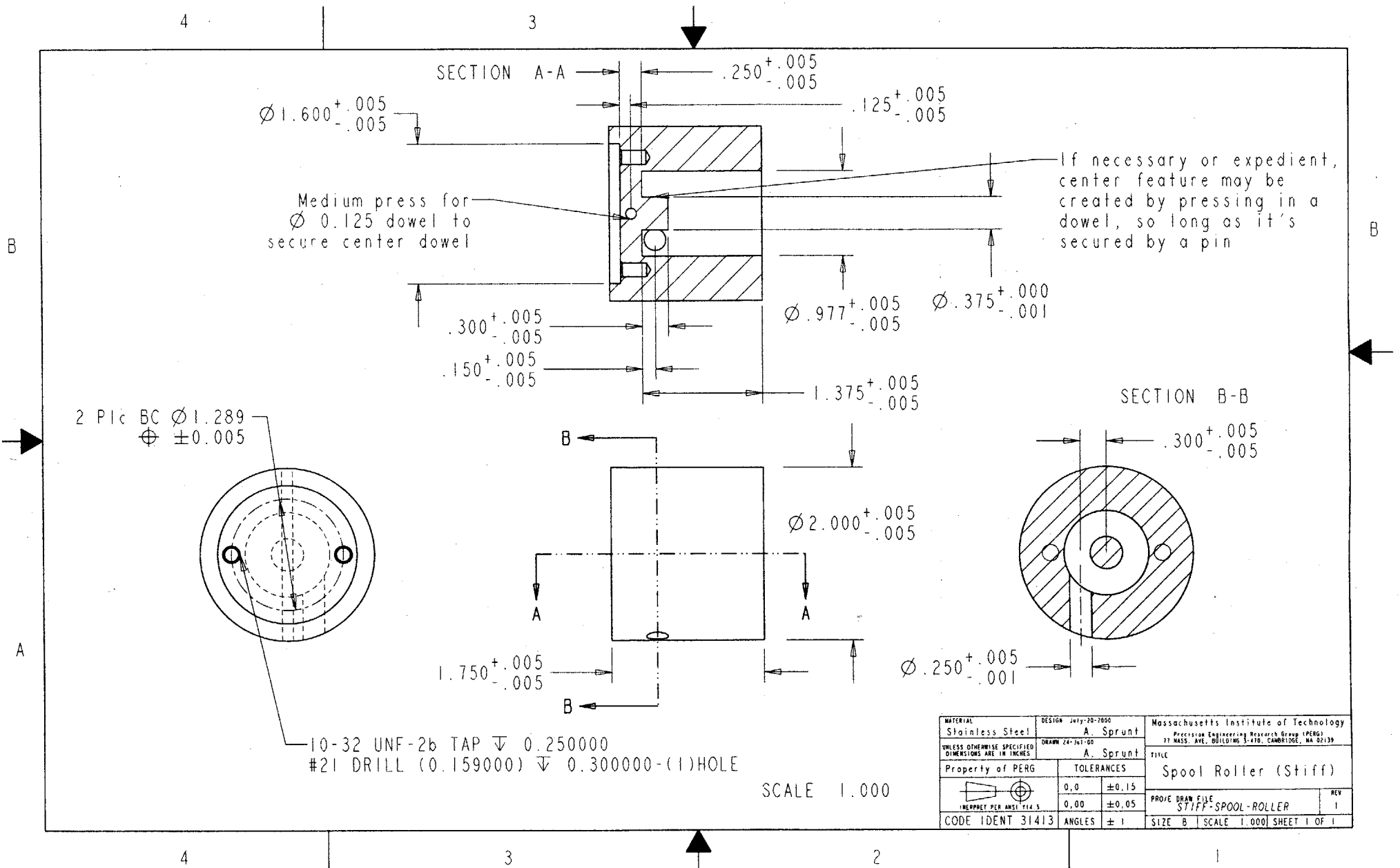

Medium press for
 \varnothing 0.125 dowel to
 secure center dowel

If necessary or expedient,
 center feature may be
 created by pressing in a
 dowel, so long as it's
 secured by a pin

2 Pk BC \varnothing 1.289
 \varnothing \pm 0.005

10-32 UNF-26 TAP ∇ 0.250000
 #21 DRILL (0.159000) ∇ 0.300000-(1)HOLE

SCALE 1.000

MATERIAL Stainless Steel	DESIGN July-20-2000 A. Sprunt	Massachusetts Institute of Technology Precision Engineering Research Group (PERG) 77 MASS. AVE., BUILDING 3-470, CAMBRIDGE, MA 02139
UNLESS OTHERWISE SPECIFIED DIMENSIONS ARE IN INCHES	DRAWN 24-JUL-00 A. Sprunt	TITLE Spool Roller (Stiff)
Property of PERG	TOLERANCES	PROJ. DRAW FILE STIFF-SPOOL-ROLLER
	0,0 \pm 0,15	REV 1
	0,00 \pm 0,05	SIZE B SCALE 1.000 SHEET 1 OF 1
CODE IDENT 31413	ANGLES \pm 1	

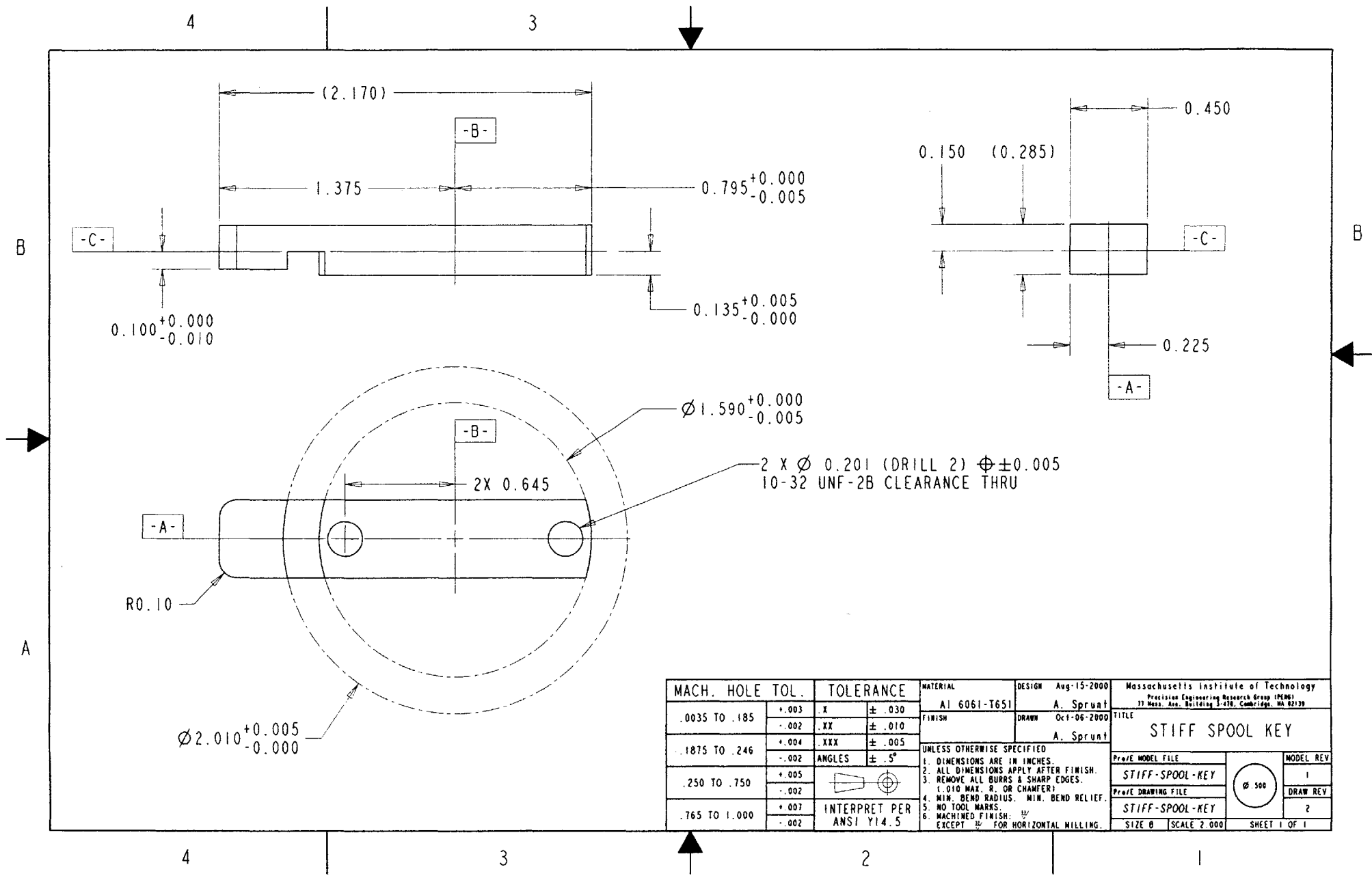

MACH. HOLE TOL.	TOLERANCE	MATERIAL	DESIGN	Aug-15-2000	Massachusetts Institute of Technology Precision Engineering Research Group (PERG) 77 Mass. Ave. Building 3-218, Cambridge, MA 02139	
.0035 TO .185	+ .003 - .002 .XX ± .010	Al 6061-T651	A. Sprunt	Oct-06-2000	TITLE STIFF SPOOL KEY	
.1875 TO .246	+ .004 - .002 ANGLES ± .5°		A. Sprunt			
.250 TO .750	+ .005 - .002	UNLESS OTHERWISE SPECIFIED 1. DIMENSIONS ARE IN INCHES. 2. ALL DIMENSIONS APPLY AFTER FINISH. 3. REMOVE ALL BURRS & SHARP EDGES. (.010 MAX. R. OR CHAMFER) 4. MIN. BEND RADIUS. MIN. BEND RELIEF. 5. NO TOOL MARKS. 6. MACHINED FINISH: $\frac{1}{2}$ EXCEPT $\frac{1}{4}$ FOR HORIZONTAL MILLING.			PROVE MODEL FILE STIFF-SPOOL-KEY	MODEL REV 1
.765 TO 1.000	+ .007 - .002 INTERPRET PER ANSI Y14.5				PROVE DRAWING FILE STIFF-SPOOL-KEY	DRAW REV 2
					SIZE B SCALE 2:000	SHEET 1 OF 1

4

3

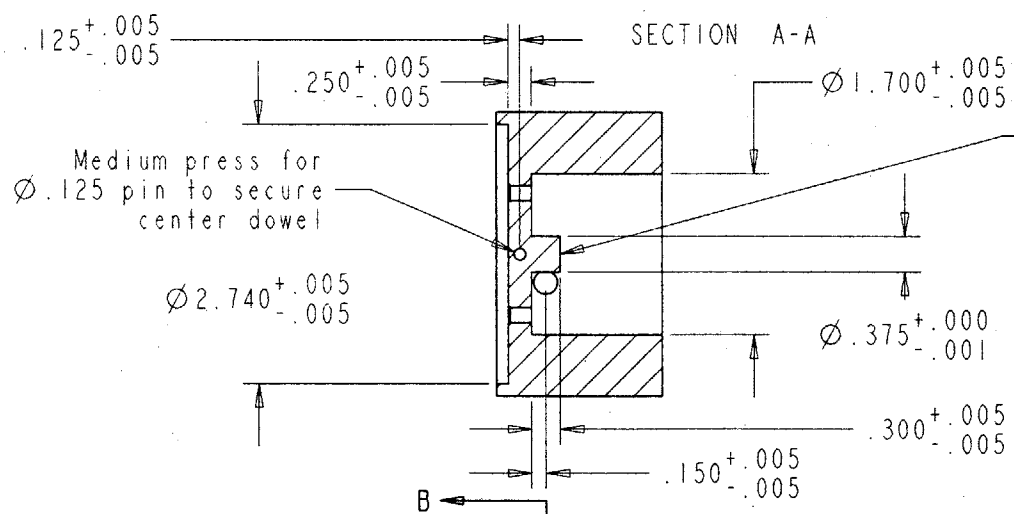

If necessary or expedient, center feature may be created by pressing in a dowel, but only if it is secured with a pin.

B

B

2 Plc BC $\phi 1.289$
 $\phi \pm 0.005$

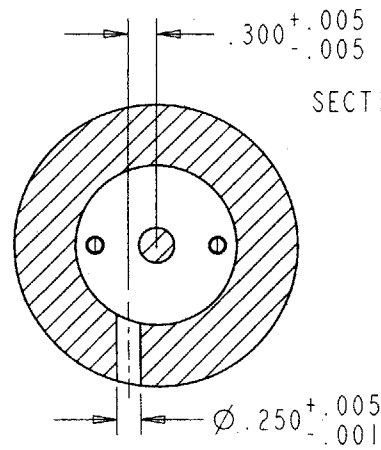
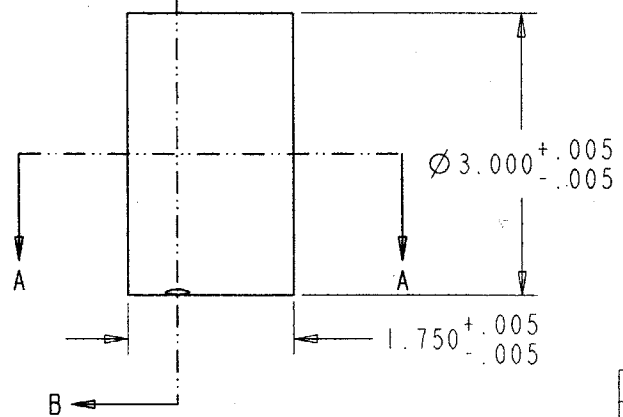
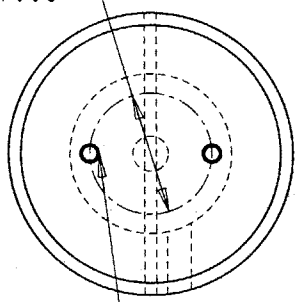

10-32 UNF-2b TAP $\nabla 0.250000$
 #21 DRILL (0.159000) $\nabla 0.300000$ -(1)HOLE SCALE 0.750

4

3



2

1

MATERIAL Stainless Steel	DESIGN July 27, 2000 A Sprunt	Massachusetts Institute of Technology Precision Engineering Research Group (PERG) 77 MASS. AVE. BUILDING 3-470, CAMBRIDGE, MA 02139
UNLESS OTHERWISE SPECIFIED DIMENSIONS ARE IN INCHES	DRAWN 27-Jul-00 A Sprunt	TITLE Idler Roller (Stiff)
Property of PERG	TOLERANCES	PROJ. DRAW FILE STIFF-IDLER-ROLLER
	0.0 ±0.15	REV 1
CODE IDENT 31413	ANGLES ± 1	SIZE B SCALE 1.000 SHEET 1 OF 1

4

3

If necessary or expedient,
center feature may be
created by pressing in a
dowel.

If creating center feature with dowel,
press a retaining pin into this
hole. Hole not necessary if not
using dowel

$.400^{+.008}$
 $-.008$

$.125^{+.004}$
 $-.004$

SECTION A-A

$\phi .375$
 $.374$

$.300^{+.008}$
 $-.008$

$\phi 1.200^{+.012}$
 $-.012$

SECTION B-B

2 Plc BC $\phi .7688$,
 $\oplus \pm 0.005$

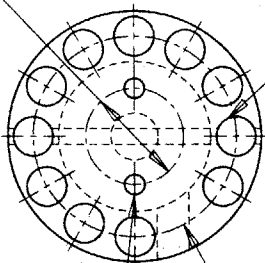

11 X $\phi .313^{+.008}$
 $-.008$
 $\nabla .525^{+.008}$
 $-.008$

Medium press for
 $\phi .125$ dowel

B

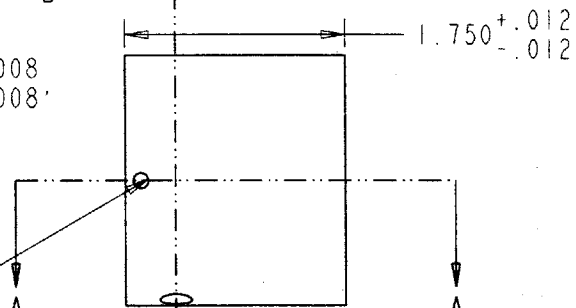

B

2 X 10-32, 2B thru
debur and $\nabla .01$
max inside

11 Plc BC $\phi 1.600^{+.012}$
 $-.012$
at $30.0^{+.5}$
 $-.5$ pitch

$\phi .250^{+.008}$
 $-.008$

$.300^{+.008}$
 $-.008$

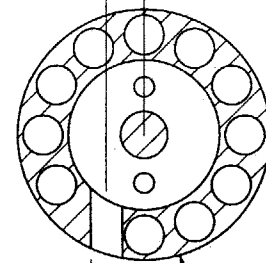

$\phi 2.000^{+.012}$
 $-.012$

SCALE 1.000

MATERIAL Stainless Steel	DESIGN July-1-2000	Massachusetts Institute of Technology Precision Engineering Research Group (PERG) 77 MASS. AVE., BUILDING 3-470, CAMBRIDGE, MA 02139
UNLESS OTHERWISE SPECIFIED DIMENSIONS ARE IN INCHES	DRAWN 14-Jul-00	TITLE Spool Roller
PROPERTY OF PERG	TOLERANCES	PROJ/DRAW FILE SP00L-ROLLER
	0.0 ±0.15	REV 1
INTERPRET PER ANSI Y14.5	0.00 ±0.05	SIZE B SCALE 1.000 SHEET 1 OF 1
CODE IDENT 31413	ANGLES ± 1	

4

3

2

1

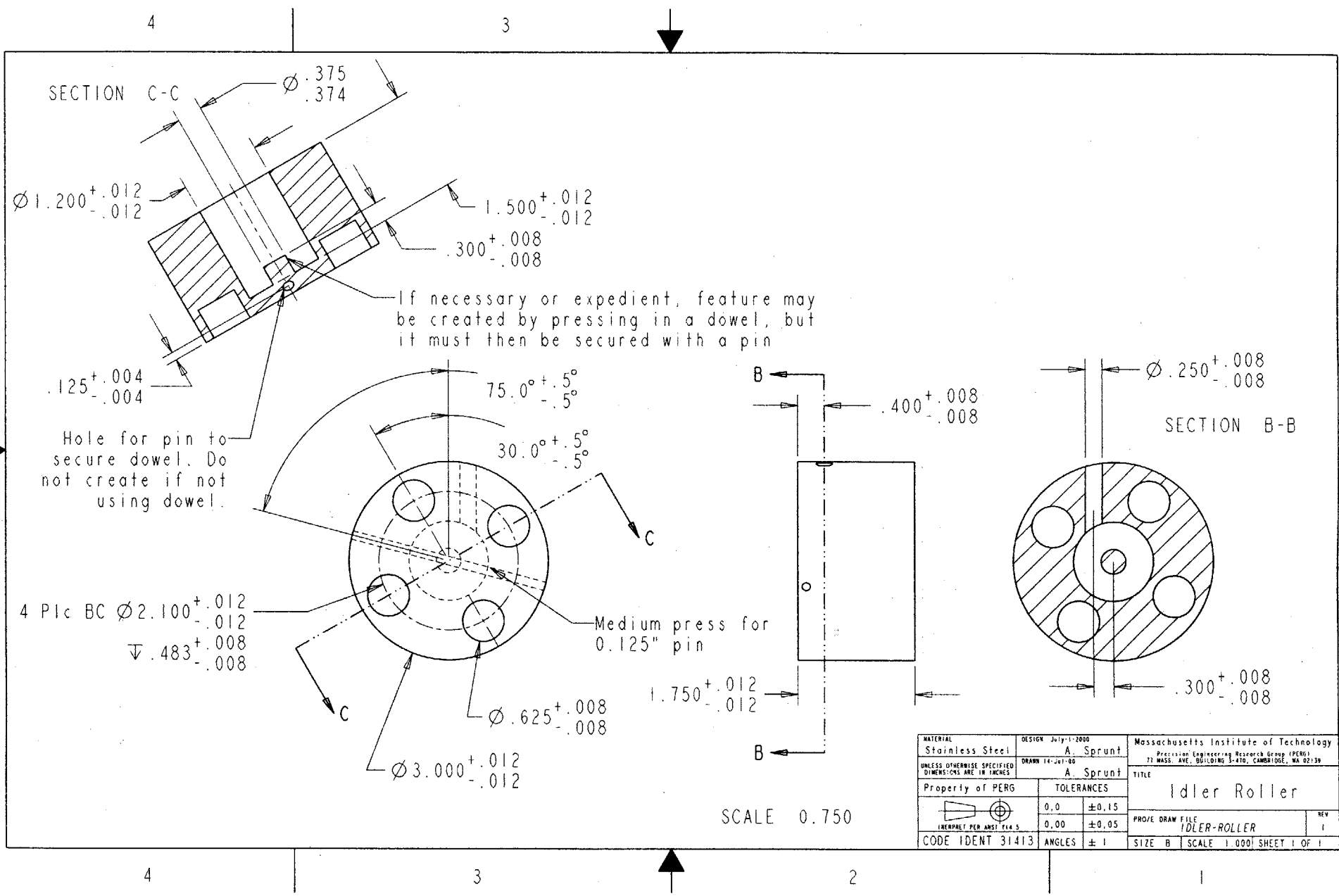

SCALE 0.750

MATERIAL Stainless Steel	DESIGN July-1-2000 A. Sprunt	Massachusetts Institute of Technology Precision Engineering Research Group (PERG) 77 MASS. AVE., BUILDING 3-810, CAMBRIDGE, MA 02139
UNLESS OTHERWISE SPECIFIED DIMENSIONS ARE IN INCHES	DRAWN 14-JUL-00 A. Sprunt	TITLE Idler Roller
Property of PERG	TOLERANCES	PROJ/ DRAW FILE IDLER-ROLLER
	0.0 ±0.15	REV 1
	0.00 ±0.05	SIZE B SCALE 1:000 SHEET 1 OF 1
CODE IDENT 31413	ANGLES ± 1	

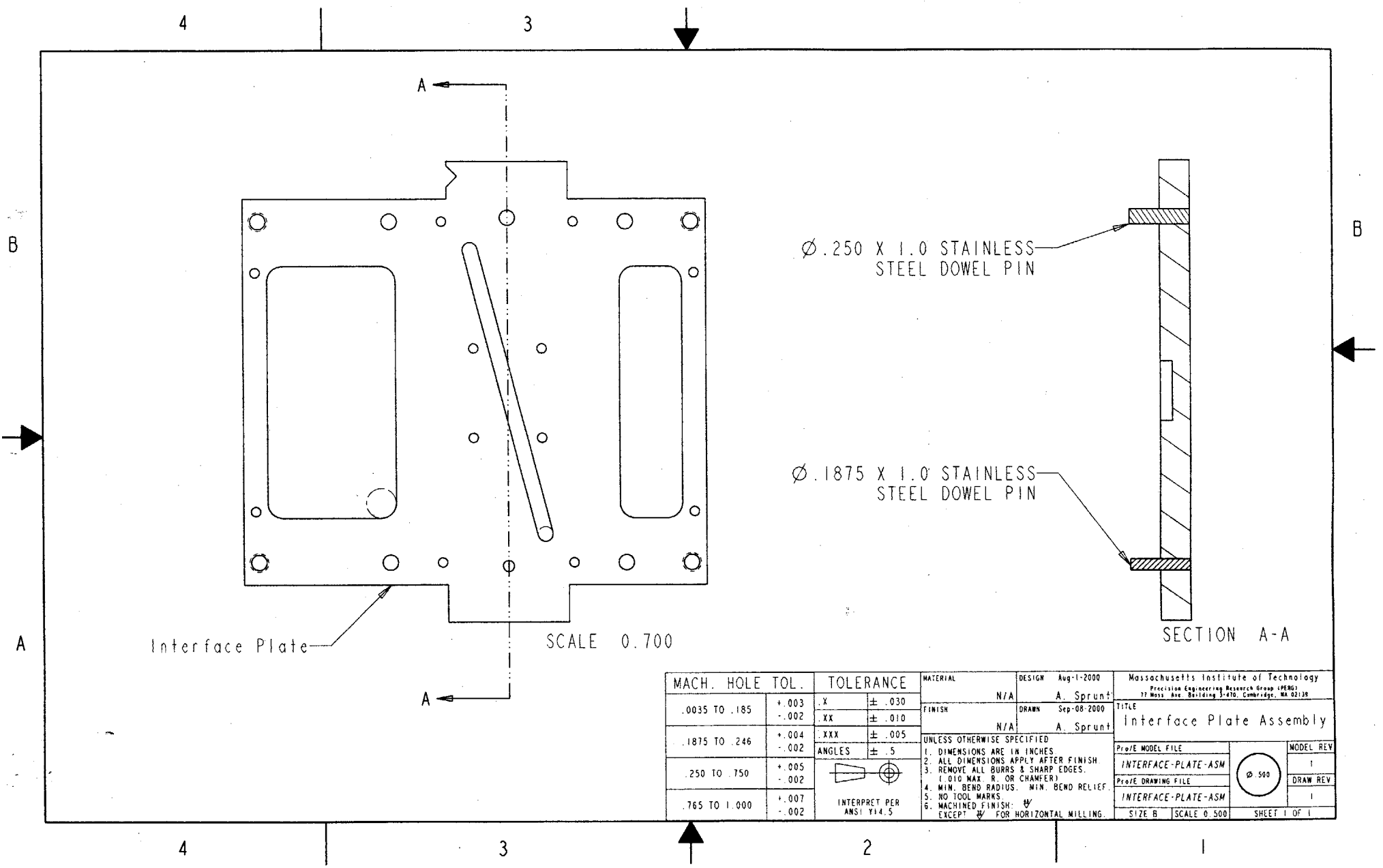

Interface Plate

SCALE 0.700

Ø.250 X 1.0 STAINLESS
STEEL DOWEL PIN

Ø.1875 X 1.0 STAINLESS
STEEL DOWEL PIN

SECTION A-A

MACH. HOLE TOL.		TOLERANCE		MATERIAL	DESIGN	Massachusetts Institute of Technology Precision Engineering Research Group (PERG) 77 Mass. Ave. Building 3-470, Cambridge, MA 02138	
.0035 TO .185	+ .003 - .002	.X .XX	± .030 ± .010	N/A	Aug-1-2000 A. Sprunt	TITLE	
.1875 TO .246	+ .004 - .002	.XXX	± .005	N/A	Sep-08-2000 A. Sprunt	Interface Plate Assembly	
.250 TO .750	+ .005 - .002	ANGLES	± .5	UNLESS OTHERWISE SPECIFIED			
.765 TO 1.000	+ .007 - .002	INTERPRET PER ANSI Y14.5		1. DIMENSIONS ARE IN INCHES 2. ALL DIMENSIONS APPLY AFTER FINISH 3. REMOVE ALL BURRS & SHARP EDGES. (.010 MAX. R. OR CHAMFER) 4. MIN. BEND RADIUS. MIN. BEND RELIEF. 5. NO TOOL MARKS. 6. MACHINED FINISH: ∇ EXCEPT ∇ FOR HORIZONTAL MILLING.			
						PROJE MODEL FILE	MODEL REV
						INTERFACE-PLATE-ASM	1
						PROJE DRAWING FILE	DRAW REV
						INTERFACE-PLATE-ASM	1
						SIZE B	SCALE 0.500
						SHEET 1 OF 1	

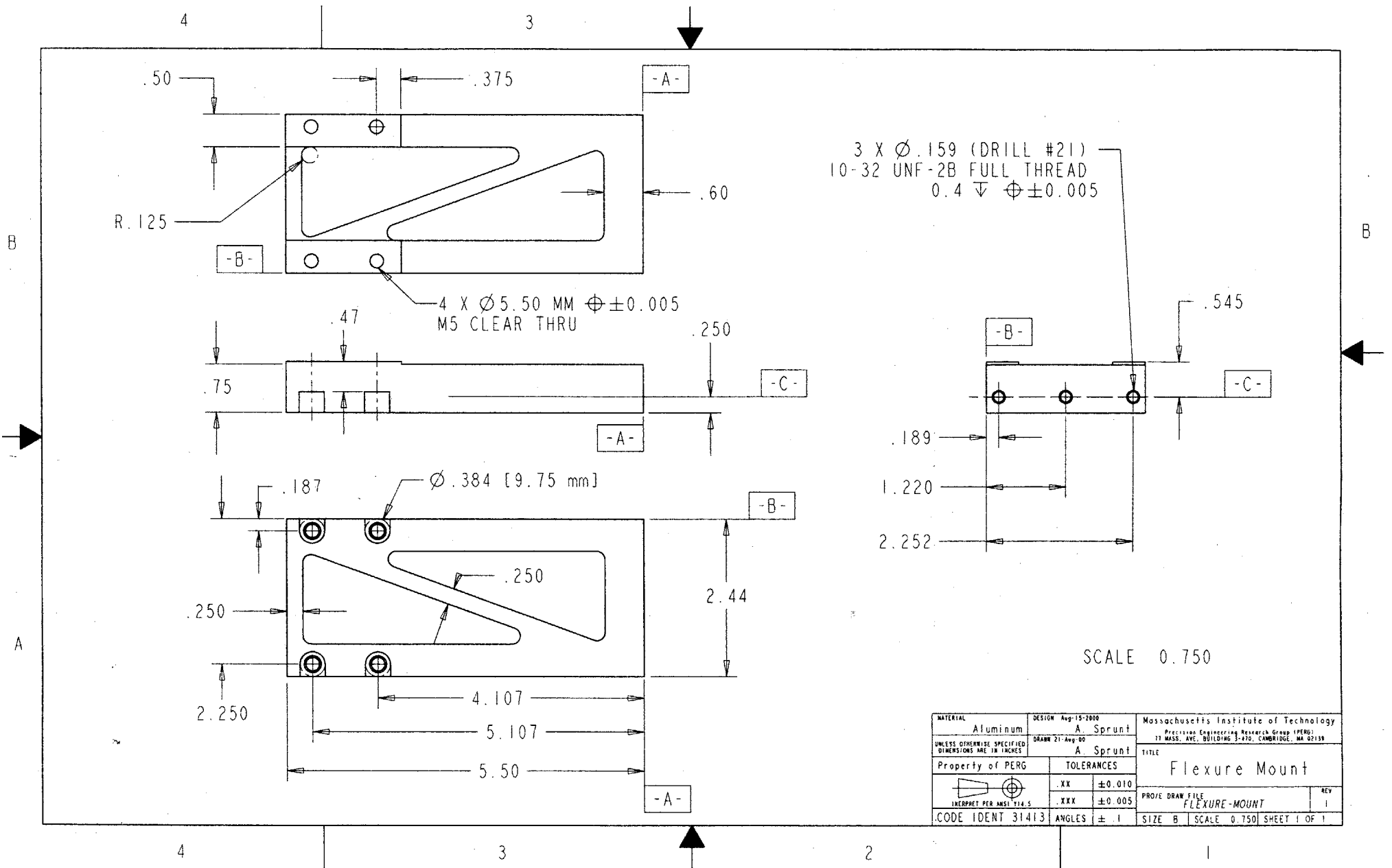

MATERIAL	DESIGN	DATE	Massachusetts Institute of Technology
Aluminum	Aug-15-2000	A. Sprunt	Precision Engineering Research Group (PERG)
UNLESS OTHERWISE SPECIFIED DIMENSIONS ARE IN INCHES	DRAWN	A. Sprunt	77 MASS. AVE. BUILDING 3-470, CAMBRIDGE, MA 02139
Property of PERG	TOLERANCES		TITLE
 INTERPRET PER ANSI Y14.5	.XX	±0.010	Flexure Mount
	.XXX	±0.005	
PROJ/ DRAW FILE	ANGLES		REV
CODE IDENT 31413	± .1	SIZE B	1
SCALE 0.750		SHEET 1 OF 1	

4

3

4 X $\varnothing 0.221$ (DRILL #2) $\oplus \pm 0.005$
 10-32 UNF-2B CLEARANCE THRU
 $\varnothing 0.375$ $\square 0.20$ ∇

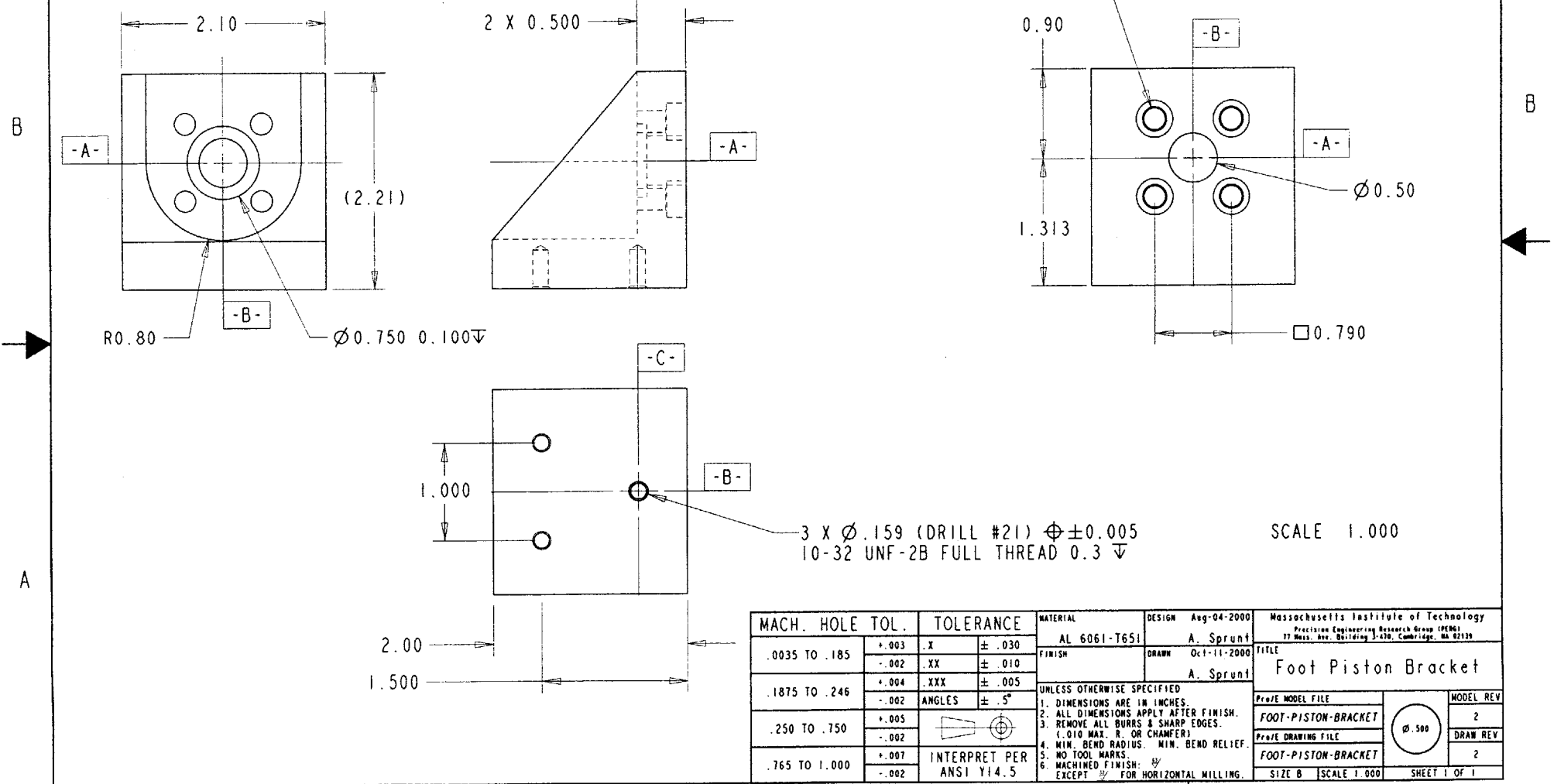

SCALE 1.000

MACH. HOLE TOL.	TOLERANCE	MATERIAL	DESIGN	Massachusetts Institute of Technology	
.0035 TO .185	+ .003 .X $\pm .030$ - .002 .XX $\pm .010$	AL 6061-T6S1	Aug-04-2000 A. Sprunt	Precision Engineering Research Group (PERG) 17 Mass. Ave. Building 3-226, Cambridge, MA 02139	
.1875 TO .246	+ .004 .XXX $\pm .005$ - .002 ANGLES $\pm .5^\circ$		Oct-11-2000 A. Sprunt	TITLE Foot Piston Bracket	
.250 TO .750	+ .005 ∇ - .002	UNLESS OTHERWISE SPECIFIED		Proj/E MODEL FILE	MODEL REV
.765 TO 1.000	+ .007 INTERPRET PER - .002 ANSI Y14.5	1. DIMENSIONS ARE IN INCHES. 2. ALL DIMENSIONS APPLY AFTER FINISH. 3. REMOVE ALL BURRS & SHARP EDGES. (.010 MAX. R. OR CHAMFER) 4. MIN. BEND RADIUS. MIN. BEND RELIEF. 5. NO TOOL MARKS. 6. MACHINED FINISH: ∇ EXCEPT ∇ FOR HORIZONTAL MILLING.		Proj/E DRAWING FILE	DRAW REV
				Foot-Piston-Bracket	2
				Foot-Piston-Bracket	2
				SIZE B SCALE 1.000	SHEET 1 OF 1

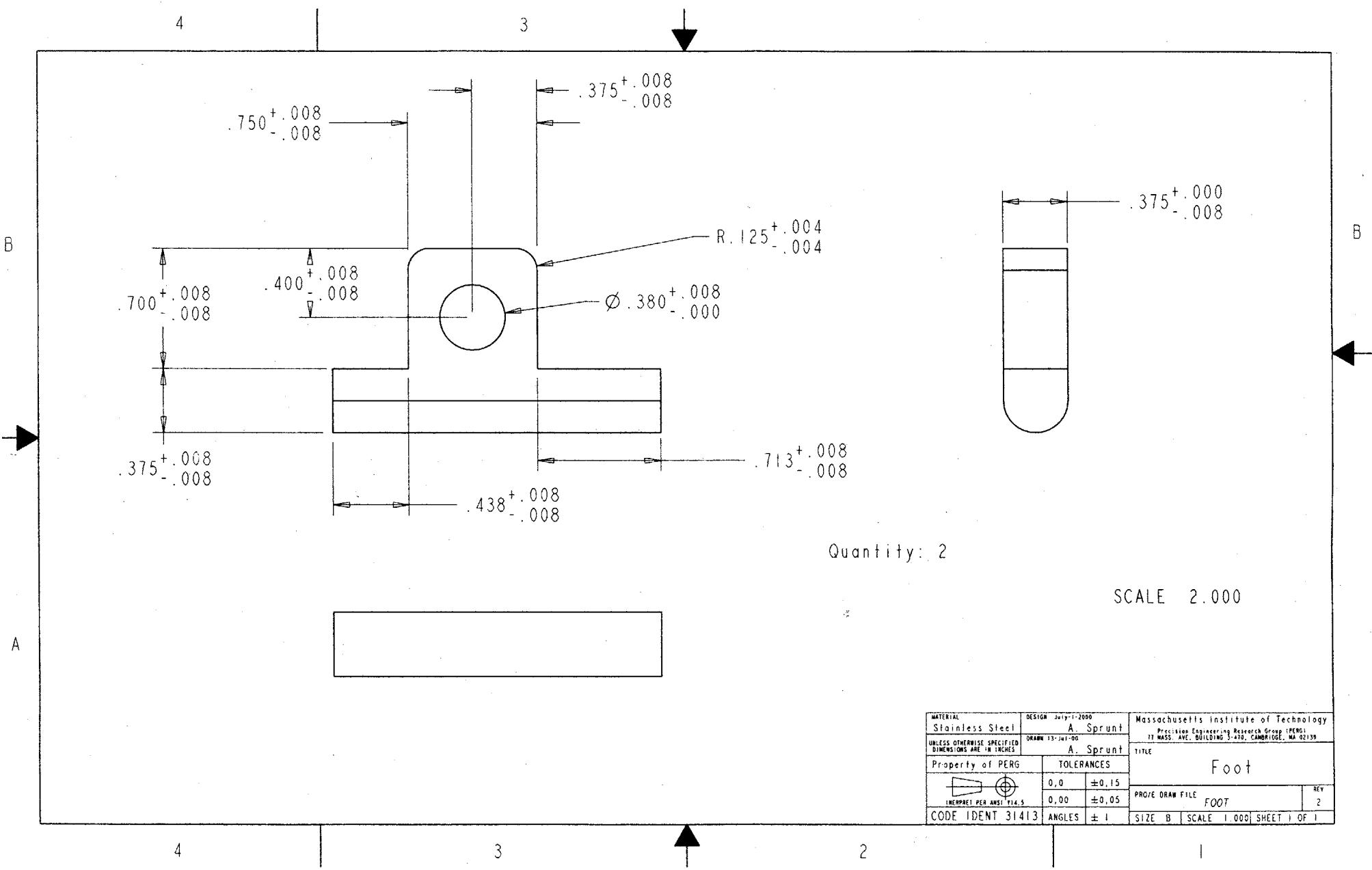

MATERIAL Stainless Steel	DESIGN July-11-2000 A. Sprunt	Massachusetts Institute of Technology Precision Engineering Research Group (PERG) 77 MASS. AVE. BUILDING 3-410, CAMBRIDGE, MA 02139
UNLESS OTHERWISE SPECIFIED DIMENSIONS ARE IN INCHES	DRAWN 13-Jul-00 A. Sprunt	TITLE Foot
Property of PERG	TOLERANCES	PROJ. DRAW FILE FOOT
	0,0 ±0,15	REV 2
CODE IDENT 31413	0,00 ±0,05	SIZE B SCALE 1.000 SHEET 1 OF 1
	ANGLES ± 1	

4

3



SECTION A-A

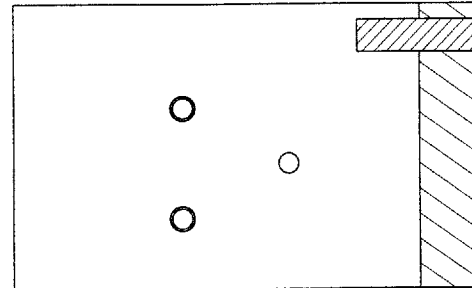
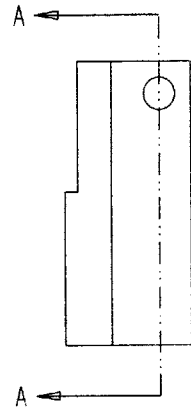

B



B





A

LEFT FLEXURE BRACKET

Ø .250 X 1.0 STAINLESS STEEL DOWEL PIN

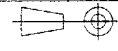
SCALE 1.000

MACH. HOLE TOL.		TOLERANCE		MATERIAL	DESIGN	Massachusetts Institute of Technology Precision Engineering Research Group (PERG) 77 Mass. Ave. Building 9-775, Cambridge, MA 02138		
.0035 TO .185	+ .003 - .002	.X .XX .XXX	± .030 ± .010 ± .005	N/A	AUG-1-2000	A. Sprunt	TITLE	
.1875 TO .246	+ .004 - .002	ANGLES	± .5	N/A	DRAWN 10-Sep-00	A. Sprunt	LEFT FLEXURE BRACKET ASSY	
.250 TO .750	+ .005 - .002	 INTERPRET PER ANSI Y14.5		UNLESS OTHERWISE SPECIFIED			ProjE MODEL FILE	
.765 TO 1.000	+ .007 - .002			1. DIMENSIONS ARE IN INCHES. 2. ALL DIMENSIONS APPLY AFTER FINISH. 3. REMOVE ALL BURRS & SHARP EDGES. (.010 MAX. R. OR CHAMFER) 4. MIN. BEND RADIUS. MIN. BEND RELIEF. 5. NO TOOL MARKS. 6. MACHINED FINISH:  EXCEPT $\frac{1}{4}$ FOR HORIZONTAL MILLING.			MODEL REV	
								DRAW REV
						SIZE B	SCALE 1.000	SHEET 1 OF 1

4

3



2

1

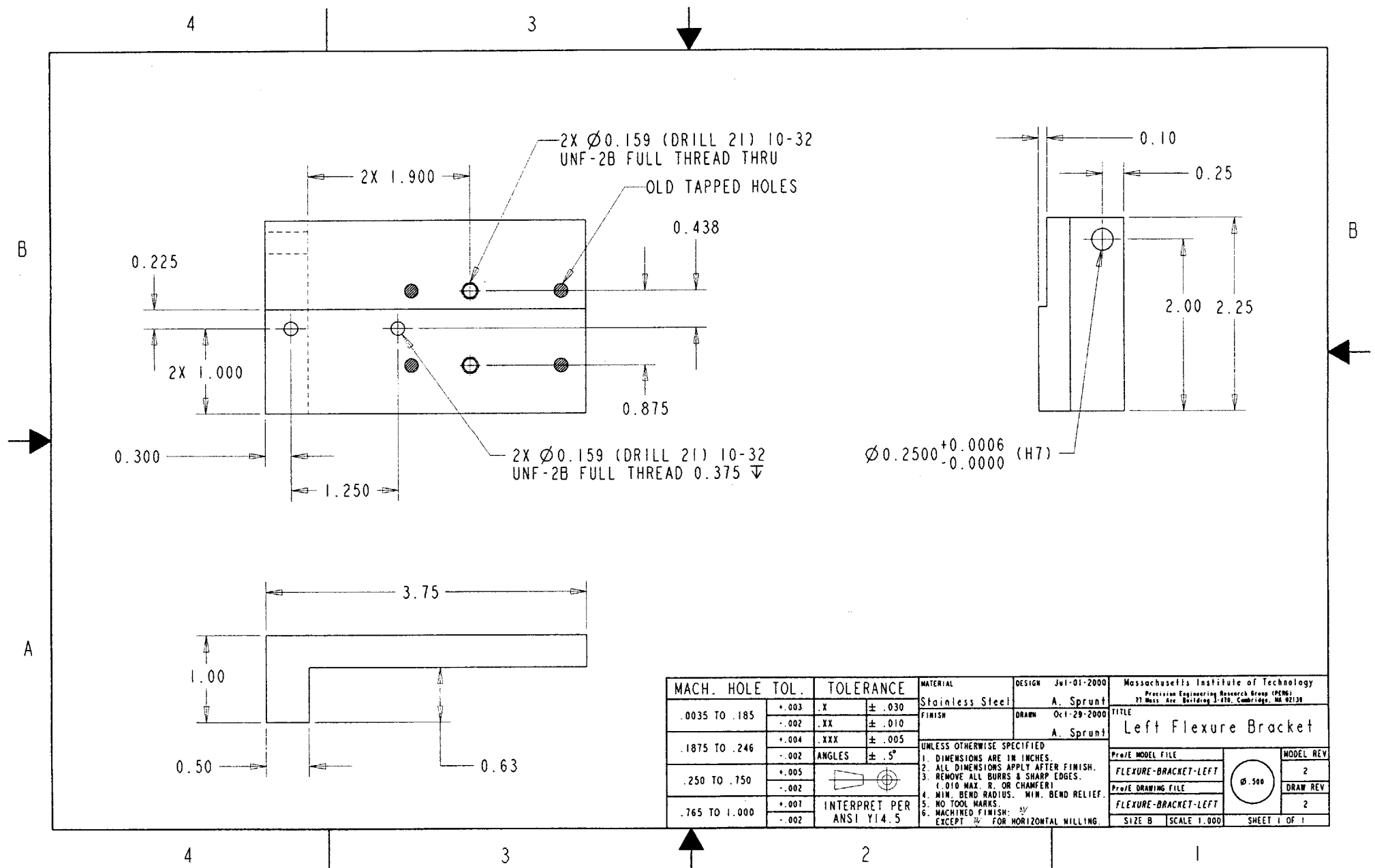

MACH. HOLE TOL.		TOLERANCE		MATERIAL	DESIGN	Massachusetts Institute of Technology Precision Engineering Research Group (PERG) 77 Mass. Ave. Building 3-210, Cambridge, MA 02139	
.0035 TO .185	+ .003	.X	$\pm .030$	Stainless Steel	Jul-01-2000	A. Sprunt	
	- .002	.XX	$\pm .010$		Oct-29-2000	A. Sprunt	
.1875 TO .246	+ .004	.XXX	$\pm .005$	UNLESS OTHERWISE SPECIFIED	1. DIMENSIONS ARE IN INCHES.		
	- .002	ANGLES	$\pm 5^\circ$		2. ALL DIMENSIONS APPLY AFTER FINISH.		
.250 TO .750	+ .005		INTERPRET PER ANSI Y14.5	3. REMOVE ALL BURRS & SHARP EDGES.			
	- .002			4. .010 MAX. R. OR CHAMFER			
.765 TO 1.000	+ .007			5. NO BEND RADIUS. MIN. BEND RELIEF.			
	- .002			6. MACHINED FINISH: $\frac{32}{100}$ EXCEPT $\frac{32}{100}$ FOR HORIZONTAL MILLING.			
TITLE					Left Flexure Bracket		
ProjE MODEL FILE					FLEXURE-BRACKET-LEFT		MODEL REV
ProjE DRAWING FILE					FLEXURE-BRACKET-LEFT		DRAW REV
ProjE MODEL FILE					FLEXURE-BRACKET-LEFT		2
ProjE DRAWING FILE					FLEXURE-BRACKET-LEFT		2
SIZE B					SCALE 1.000		SHEET 1 OF 1

4

3

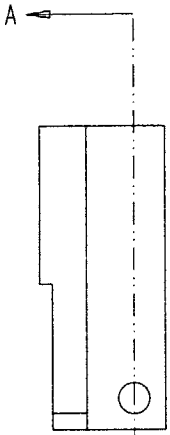

SCALE 1.000

SECTION A-A

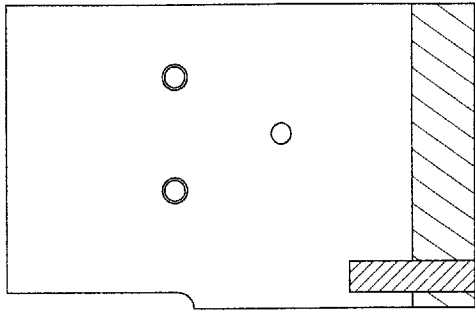

B

B

A

RIGHT FLEXURE BRACKET

Ø .250 X 1.0 STAINLESS STEEL DOWEL PIN

A

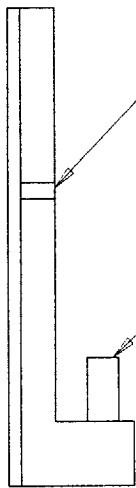

MACH. HOLE TOL.		TOLERANCE		MATERIAL	DESIGN AUG-1-2000	Massachusetts Institute of Technology Precision Engineering Research Group (PERG) 77 Mass. Ave. Building 3-170, Cambridge, MA 02139	
.0035 TO .185	+ .003 - .002	.X = .030 .XX = .010 .XXX = .005		N/A	A. Sprunt	TITLE	
.1875 TO .246	+ .004 - .002	ANGLES ± .5		N/A	A. Sprunt	RIGHT FLEXURE BRACKET ASSY	
.250 TO .750	+ .005 - .002			UNLESS OTHERWISE SPECIFIED			
.765 TO 1.000	+ .007 - .002	INTERPRET PER ANSI Y14.5		1. DIMENSIONS ARE IN INCHES. 2. ALL DIMENSIONS APPLY AFTER FINISH. 3. REMOVE ALL BURRS & SHARP EDGES. (.010 MAX. R. OR CHAMFER) 4. MIN. BEND RADIUS. MIN. BEND RELIEF. 5. NO TOOL MARKS. 6. MACHINED FINISH: EXCEPT FOR HORIZONTAL MILLING.			
						ProjE MODEL FILE	MODEL REV
						FLEXURE-BRACKET-RIGHT-ASM	1
						ProjE DRAWING FILE	DRAW REV
						FLEXURE-BRACKET-RIGHT-ASM	1
				SIZE B	SCALE 1.000	SHEET 1 OF 1	

4

3



2

1

4

3



2X Ø0.159 (DRILL 21) 10-32
UNF-2B FULL THREAD 0.375

2X Ø0.159 (DRILL 21) 10-32
UNF-2B FULL THREAD THRU

OLD TAPPED HOLES

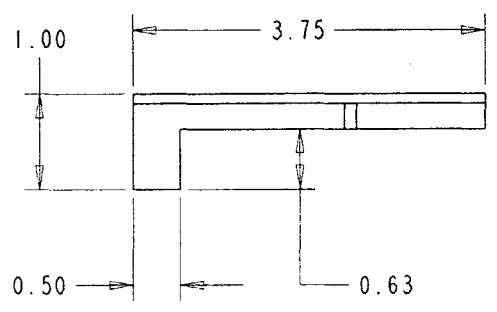
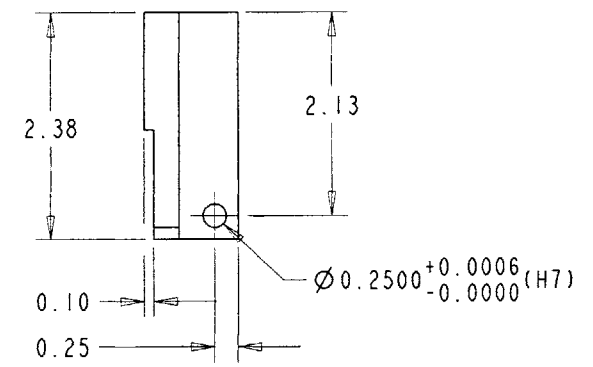
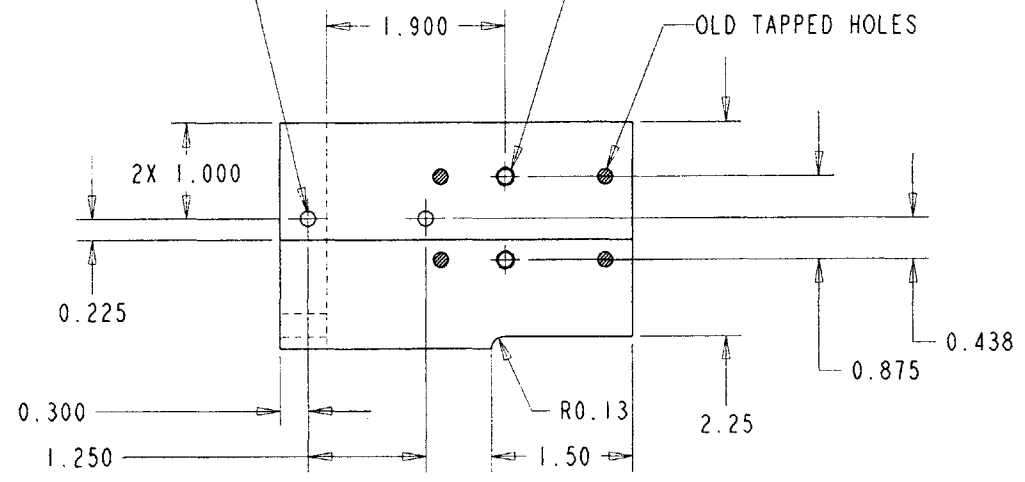

B

B

A

4

3



2

1

MACH. HOLE TOL.	TOLERANCE	MATERIAL	DESIGN	Massachusetts Institute of Technology Precision Engineering Research Group (PERG) 77 Mass. Ave. Building 3-47B, Cambridge, MA 02139
.0035 TO .185	+ .003 - .002 .XX ± .010	304 STAINLESS	Jul-01-2000 A. Sprunt	TITLE Right Flexure Bracket
.1875 TO .246	+ .004 - .002 .XXX ± .005 ANGLES ± .5°	FINISH	Oct-11-2000 A. Sprunt	
.250 TO .750	+ .005 - .002	UNLESS OTHERWISE SPECIFIED 1. DIMENSIONS ARE IN INCHES. 2. ALL DIMENSIONS APPLY AFTER FINISH. 3. REMOVE ALL BURRS & SHARP EDGES. (.010 MAX. R. OR CHAMFER) 4. MIN. BEND RADIUS. MIN. BEND RELIEF. 5. NO TOOL MARKS. 6. MACHINED FINISH: EXCEPT FOR HORIZONTAL MILLING.		PROJ MODEL FILE FLEXURE-BRACKET-RIGHT
.765 TO 1.000	+ .007 - .002 INTERPRET PER ANSI Y14.5			PROJ DRAWING FILE FLEXURE-BRACKET-RIGHT
				MODEL REV 3
				DRAW REV 3
				SIZE B SCALE 1:000 SHEET 1 OF 1

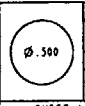

4

3



4X \varnothing 0.221 (DRILL 2)
 \varnothing \pm 0.005 10-32 UNF
 2B CLEARANCE THRU
 \varnothing 0.375 \square 0.200 ∇

INSPECT "DIAMETER" HOLES WITH
 SUPPLIED PG-100 PIN GAGE

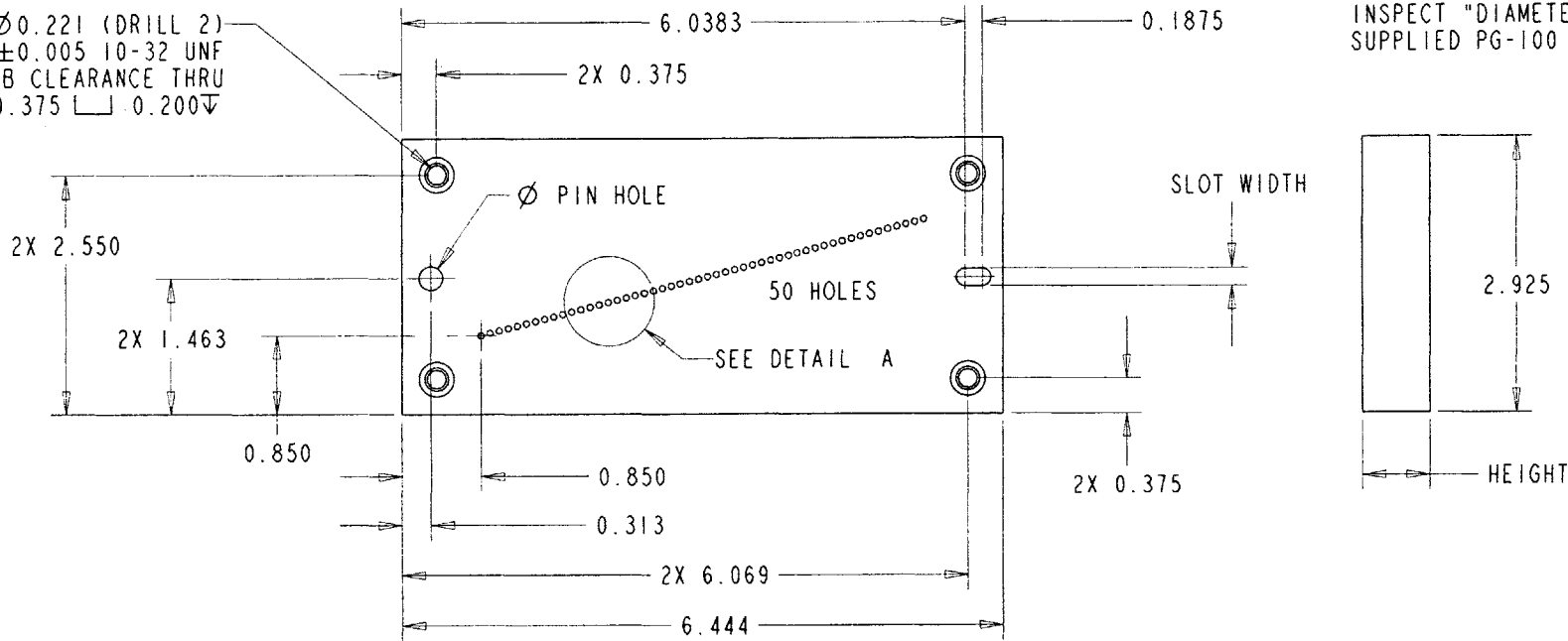

B



50X 0.097
 NON-CUMULATIVE

INSTANCE	HEIGHT	MAX_DIAMETER	MIN_DIAMETER	PIN HOLE	SLOT WIDTH
100-16-SERIES	0.775	0.069	0.067	\varnothing 0.255	0.193

50X 0.025
 NON-CUMULATIVE

DETAIL A
 SCALE 2.000

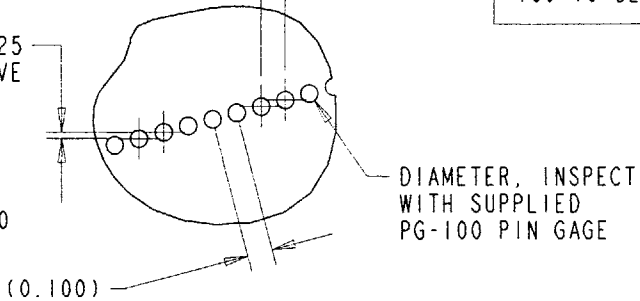

A

4

3



2

1

MACH. HOLE TOL.	TOLERANCE	MATERIAL	DESIGN	Massachusetts Institute of Technology Precision Engineering Research Group (PERG) 77 Mass. Ave. Building 3-470, Cambridge, MA 02139	
.0035 TO .185	+ .003 - .002	4030 TORLON	Jul-01-2000 A. Sprunt	TITLE EXPERIMENT COUPONS	
.1875 TO .246	+ .004 - .002	FINISH	Oct-28-2000 A. Sprunt	Prw/E MODEL FILE EX-COUPON	MODEL REV 2
.250 TO .750	+ .005 - .002	UNLESS OTHERWISE SPECIFIED 1. DIMENSIONS ARE IN INCHES. 2. ALL DIMENSIONS APPLY AFTER FINISH. 3. REMOVE ALL BURRS & SHARP EDGES. (.010 MAX. R. OR CHAMFER) 4. MIN. BEND RADIUS. MIN. BEND RELIEF. 5. NO TOOL MARKS. 6. MACHINED FINISH: ∇		Prw/E DRAWING FILE EXPERIMENT-COUPONS	DRAW REV 2
.765 TO 1.000	+ .007 - .002	INTERPRET PER ANSI Y14.5		SIZE B SCALE 0.750	SHEET 1 OF 1

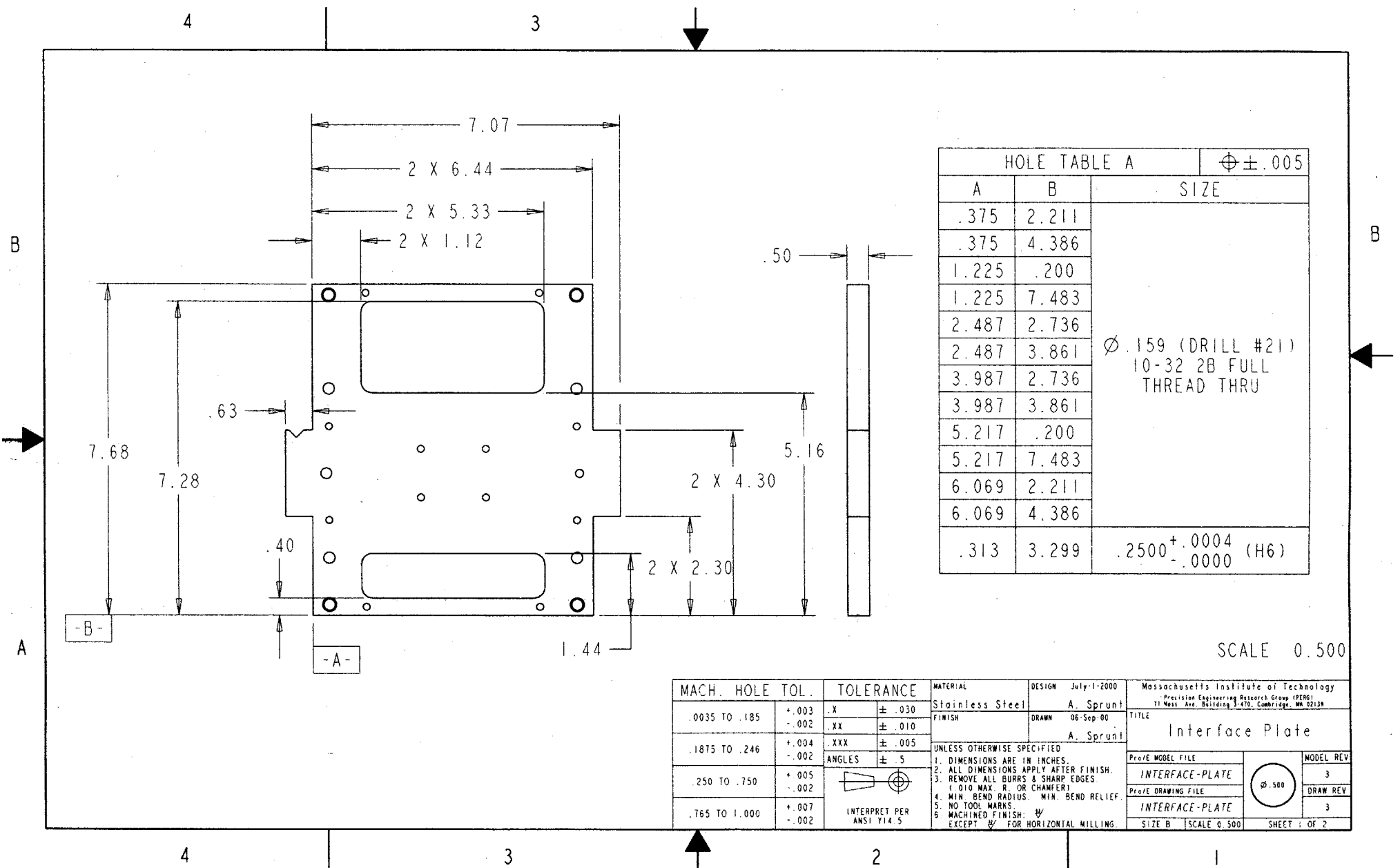

HOLE TABLE A		$\pm .005$
A	B	SIZE
.375	2.211	$\varnothing .159$ (DRILL #21) 10-32 2B FULL THREAD THRU
.375	4.386	
1.225	.200	
1.225	7.483	
2.487	2.736	
2.487	3.861	
3.987	2.736	
3.987	3.861	
5.217	.200	
5.217	7.483	
6.069	2.211	$.2500^{+.0004}$ $-.0000$ (H6)
6.069	4.386	

SCALE 0.500

MACH. HOLE TOL.	TOLERANCE	MATERIAL	DESIGN	Massachusetts Institute of Technology
.0035 TO .185	+ .003 - .002	.X $\pm .030$.XX $\pm .010$	July-1-2000 A. Sprunt	Precision Engineering Research Group (PERG) 77 Mass. Ave. Building 3-470, Cambridge, MA 02138
.1875 TO .246	+ .004 - .002	.XXX $\pm .005$ ANGLES ± 5	FINISH DRAWN 06-Sep-00 A. Sprunt	TITLE Interface Plate
.250 TO .750	+ .005 - .002	UNLESS OTHERWISE SPECIFIED 1. DIMENSIONS ARE IN INCHES. 2. ALL DIMENSIONS APPLY AFTER FINISH. 3. REMOVE ALL BURRS & SHARP EDGES (.010 MAX. R. OR CHAMFER) 4. MIN. BEND RADIUS. MIN. BEND RELIEF. 5. NO TOOL MARKS. 6. MACHINED FINISH: $\#$ EXCEPT $\#$ FOR HORIZONTAL MILLING.	Prof# MODEL FILE INTERFACE-PLATE Prof# DRAWING FILE INTERFACE-PLATE	MODEL REV 3 DRAW REV 3
.765 TO 1.000	+ .007 - .002		INTERPRET PER ANSI Y14.5	SIZE B SCALE 0.500

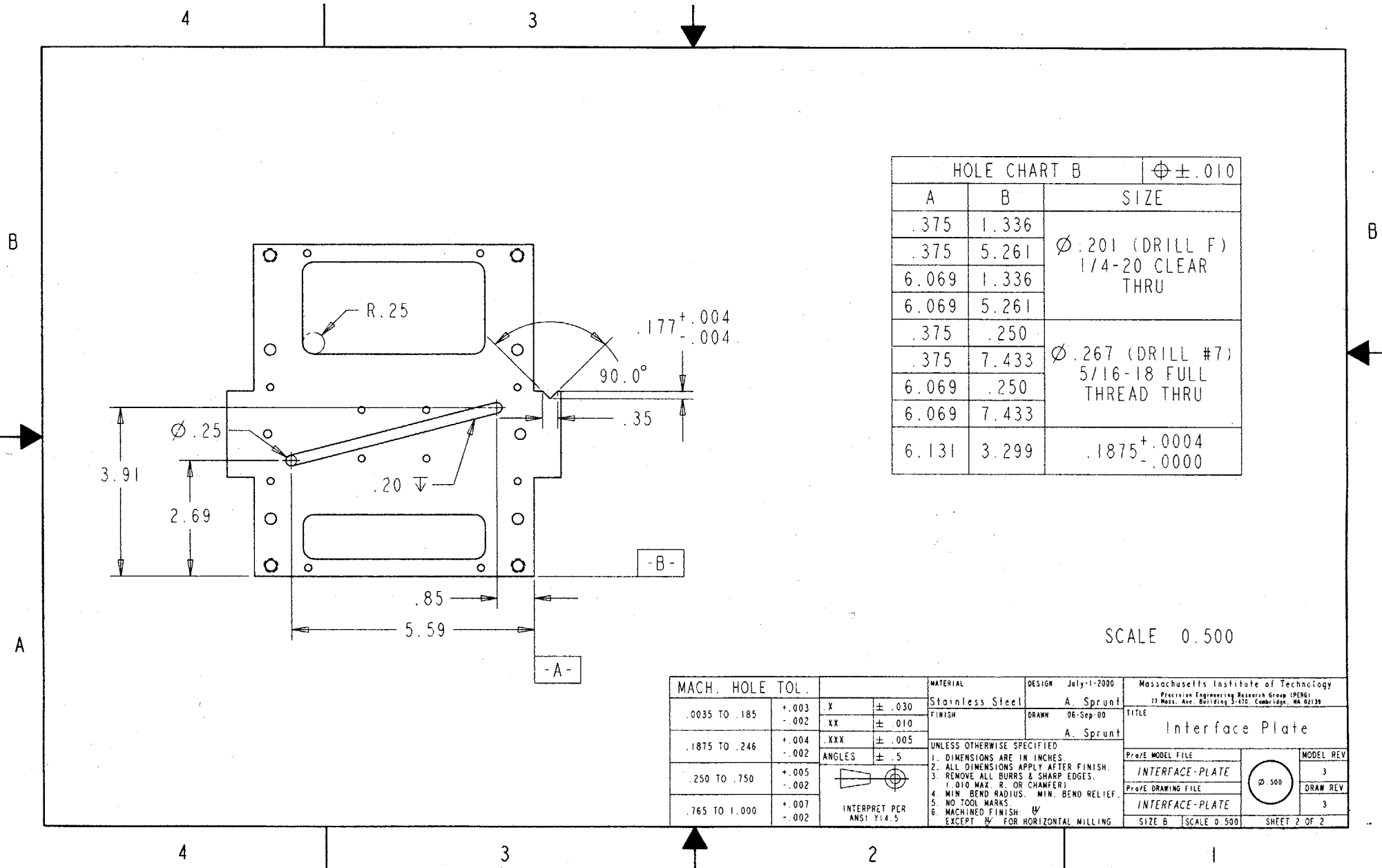

HOLE CHART B		$\pm .010$
A	B	SIZE
.375	1.336	$\varnothing .201$ (DRILL F) 1/4-20 CLEAR THRU
.375	5.261	
6.069	1.336	
6.069	5.261	
.375	.250	$\varnothing .267$ (DRILL #7) 5/16-18 FULL THREAD THRU
.375	7.433	
6.069	.250	
6.069	7.433	
6.131	3.299	$.1875^{+.0004}_{-.0000}$

SCALE 0.500

MACH. HOLE TOL.		MATERIAL		DESIGN	Massachusetts Institute of Technology	
.0035 TO .185	+ .003 - .002	X	$\pm .030$	July-1-2000	Precision Engineering Research Group (PERG) 77 Mass. Ave. Building 3-470, Cambridge, MA 02139	
.1875 TO .246	+ .004 - .002	XX	$\pm .010$	A. Sprunt	TITLE	
.250 TO .750	+ .005 - .002	.XXX	$\pm .005$	FINISH	INTERFACE-PLATE	
.765 TO 1.000	+ .007 - .002	ANGLES	$\pm .5$	DRAWN	INTERFACE-PLATE	
				A. Sprunt	Prof. MODEL FILE INTERFACE-PLATE Prof. DRAWING FILE INTERFACE-PLATE	
		INTERPRET PER ANSI Y14.5		UNLESS OTHERWISE SPECIFIED 1. DIMENSIONS ARE IN INCHES. 2. ALL DIMENSIONS APPLY AFTER FINISH. 3. REMOVE ALL BURRS & SHARP EDGES. (.010 MAX. R. OR CHAMFER) 4. MIN. BEND RADIUS. MIN. BEND RELIEF. 5. NO TOOL MARKS 6. MACHINED FINISH UNLESS OTHERWISE SPECIFIED		MODEL REV 3 DRAW REV 3
				SIZE B SCALE 0.500		SHEET 2 OF 2

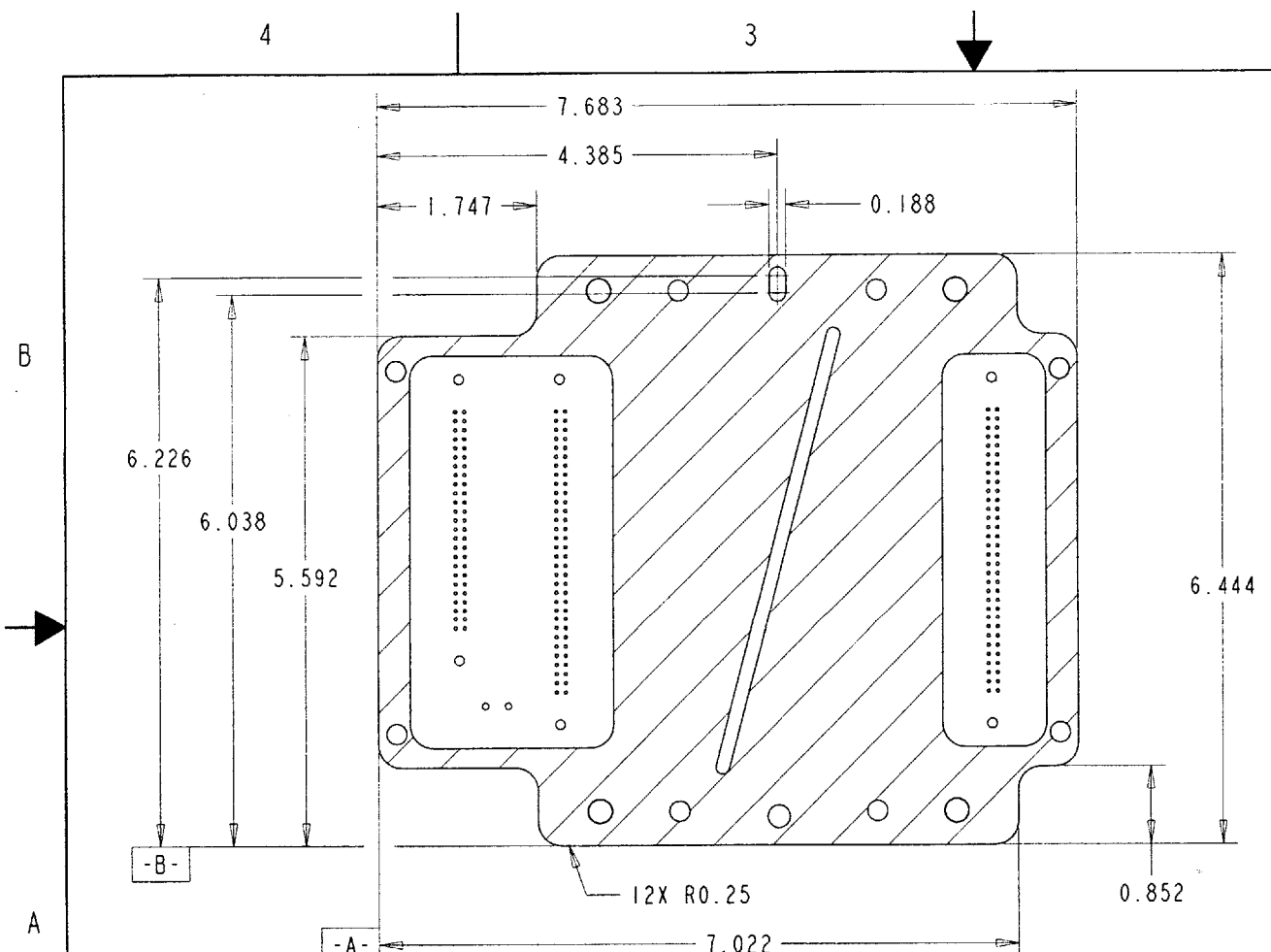

TOOLING HOLES		
A	B	SIZE
0.200	1.225	Ø0.221 (DRILL 2)
0.200	5.217	Ø0.221 (DRILL 2)
2.422	0.375	Ø0.266 (DRILL 17/64)
2.422	6.069	Ø0.266 (DRILL 17/64)
3.297	0.375	Ø0.221 (DRILL 2)
3.297	6.069	Ø0.221 (DRILL 2)
4.385	0.313	Ø0.250 ^{+0.004} _{-0.000} (H10)
5.472	0.375	Ø0.221 (DRILL 2)
5.472	6.069	Ø0.221 (DRILL 2)
6.347	0.375	Ø0.266 (DRILL 17/64)
6.347	6.069	Ø0.266 (DRILL 17/64)
7.483	1.225	Ø0.221 (DRILL 2)
7.483	5.217	Ø0.221 (DRILL 2)

ALL HOLES ARE UNPLATED UNLESS OTHERWISE SPECIFIED $\text{Ø} \pm 0.005$

J2 EXPERIMENT SPECIFICS		
BOARD	EXPERIMENT	J2 GEOMETRY
K1-019-00	DOUBLE ENDED SPRING PINS	Ø0.090 PLATED PADS
K1-020-00	100-16 SERIES SPRING PINS	Ø0.050 PLATED THRU HOLES

MACH. HOLE TOL.	TOLERANCE	
.0035 TO .185	+ .003 X	± .030
	- .002 .XX	± .010
	+ .004 .XXX	± .005
.1875 TO .246	- .002	ANGLES ± 5°
	+ .005	
.250 TO .750	- .002	
	+ .007	INTERPRET PER ANSI Y14.5
.765 TO 1.000	- .002	

MATERIAL	DESIGN Jun-29-2000	Massachusetts Institute of Technology
FR-4	A. Sprunt	Precision Engineering Research Group (PERG)
FINISH	DRAWN Nov-02-2000	37 Mass. Ave. Building 3-270, Cambridge, MA 02139
	A. Sprunt	TITLE
UNLESS OTHERWISE SPECIFIED		274-674-00
1. DIMENSIONS ARE IN INCHES.		PROJ. MODEL FILE
2. ALL DIMENSIONS APPLY AFTER FINISH.		CIRCUIT-BOARD
3. REMOVE ALL BURRS & SHARP EDGES.		PROJ. DRAWING FILE
4. (1.0 MAX. R. OR CHAMFER)		274-674-00
5. MIN. BEND RADIUS. MIN. BEND RELIEF.		Ø.500
6. MACHINED FINISH. ψ		EXCEPT ψ FOR HORIZONTAL MILLING.
SIZE B	SCALE 0.750	SHEET 1 OF 2

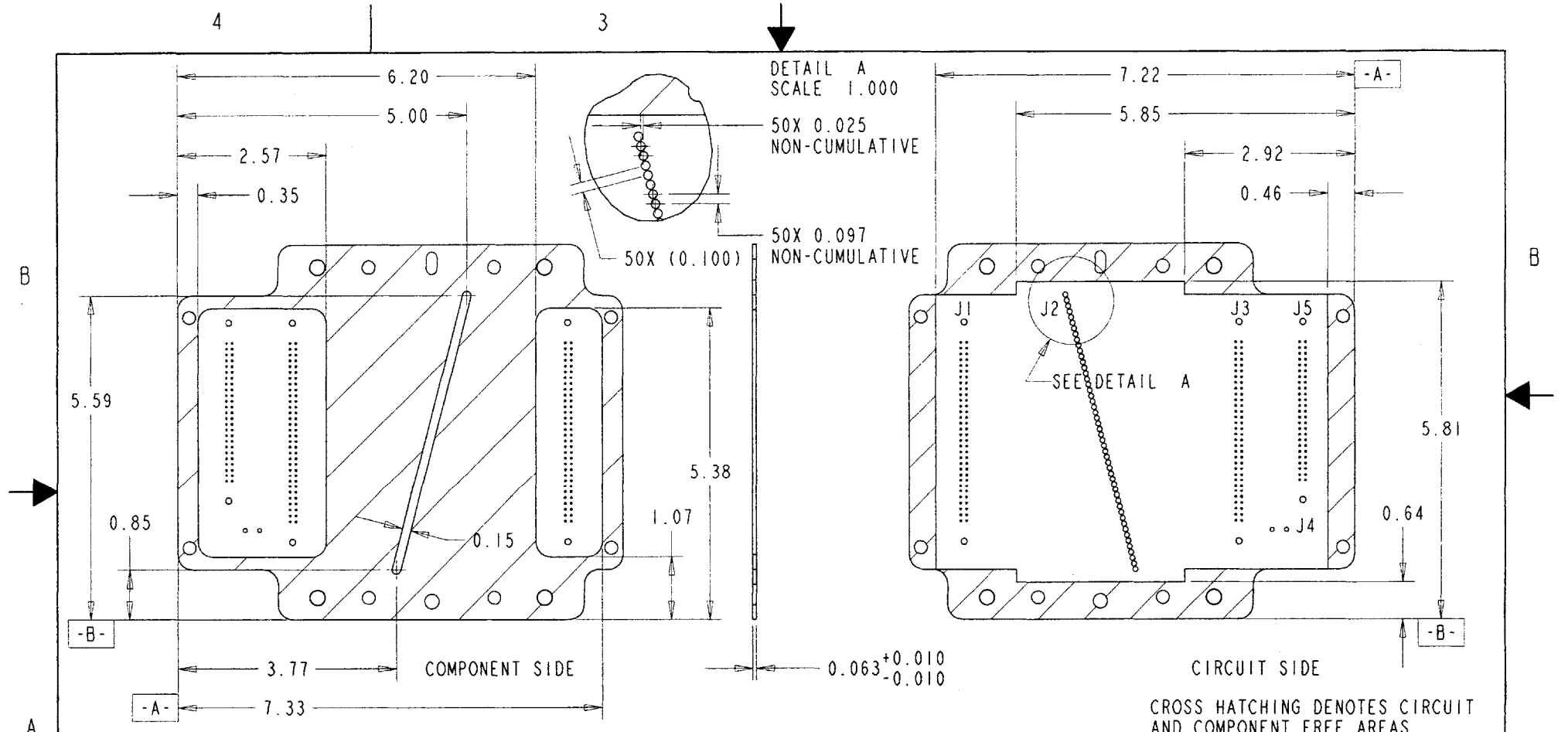

CONNECTOR PIN ONE LOCATIONS

	A	B	CONNECTOR TYPE	DRAWING	TOLERANCE
J1	6.700	4.775	AMP 1-1111008-2	C111008	± 0.010
J2	4.997	5.593	SPRING PINS - SEE J2 EXPERIMENT TABLE		± 0.005
J3	1.950	4.775	AMP 1-1111008-2	C111008	
J4	1.175	1.525	AMP 350428-2	350428	± 0.010
J5	0.850	4.775	AMP 1-1111008-0	C111008	

MACH. HOLE TOL.	TOLERANCE	MATERIAL	DESIGN	Massachusetts Institute of Technology
.0035 TO .185	+ .003 - .002 XX $\pm .030$ $\pm .010$	FR-4	Jun-29-2000 A. Sprunt	Precision Engineering Research Group (PERG) 77 Mass. Ave. Building 3-010, Cambridge, MA 02139
.1875 TO .246	+ .004 - .002 XXX $\pm .005$		Nov-03-2000 A. Sprunt	TITLE 274-674-00
.250 TO .750	+ .005 - .002 INTERPRET PER ANSI Y14.5	UNLESS OTHERWISE SPECIFIED		PROJ MODEL FILE CIRCUIT-BOARD
.765 TO 1.000		1. DIMENSIONS ARE IN INCHES. 2. ALL DIMENSIONS APPLY AFTER FINISH. 3. REMOVE ALL BURRS & SHARP EDGES. 4. MIN. BEND RADIUS. MIN. BEND RELIEF. 5. NO TOOL MARKS. 6. MACHINED FINISH: \forall EXCEPT \forall FOR HORIZONTAL MILLING.		PROJ DRAWING FILE 274-674-00
				MODEL REV 4
				DRAW REV 4
				SIZE B SCALE 0.600 SHEET 2 OF 2

4

3



B

B

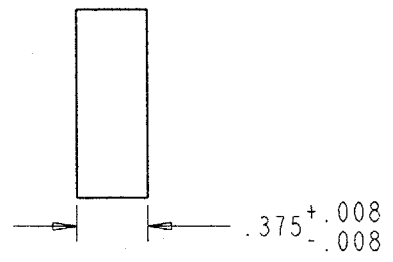
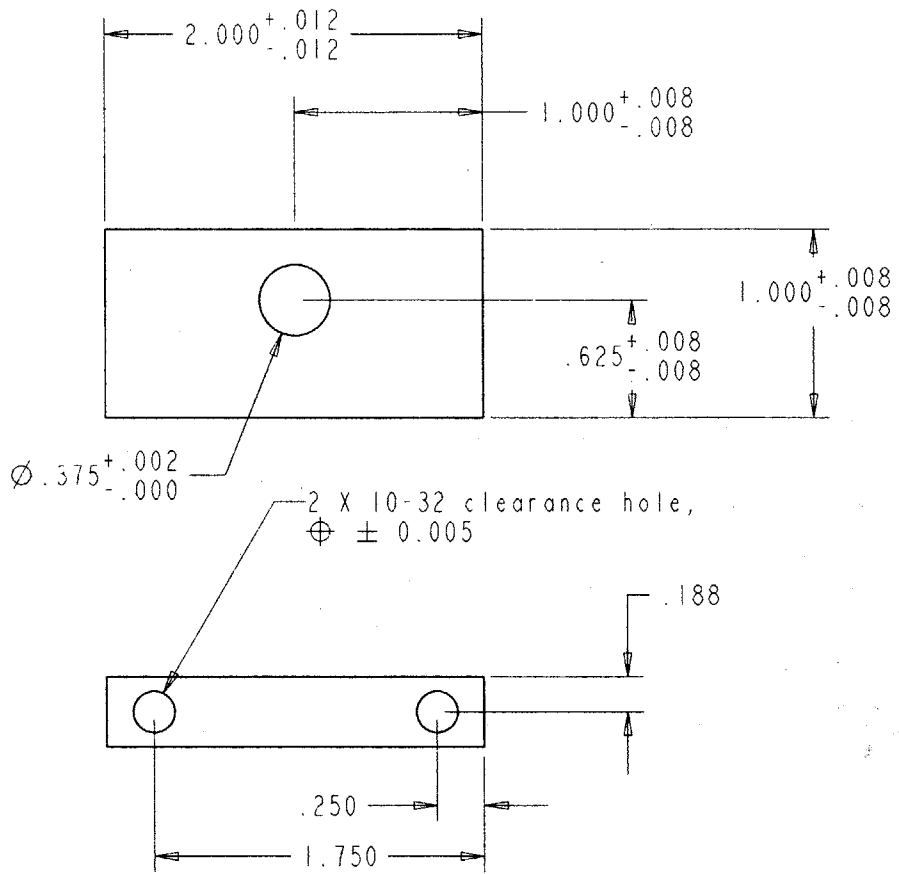

A

4

3



2

1

SCALE 1.500

MATERIAL Stainless Steel	DESIGN July-1-2000 A. Sprunt	Massachusetts Institute of Technology Professional Engineering Research Group (PERG) 77 MASS. AVE., BUILDING 3-470, CAMBRIDGE, MA 02139
UNLESS OTHERWISE SPECIFIED DIMENSIONS ARE IN INCHES	DRAWN 13-JUL-00 A. Sprunt	TITLE Clevis Bracket
Property of PERG	TOLERANCES	PROJ/ DRAW FILE CLEVIS-BRACKET
	0,0 ±0,15	REV 1
CODE IDENT 31413	0,00 ±0,05	SIZE B SCALE 1,000 SHEET 1 OF 1
	ANGLES ± 1	

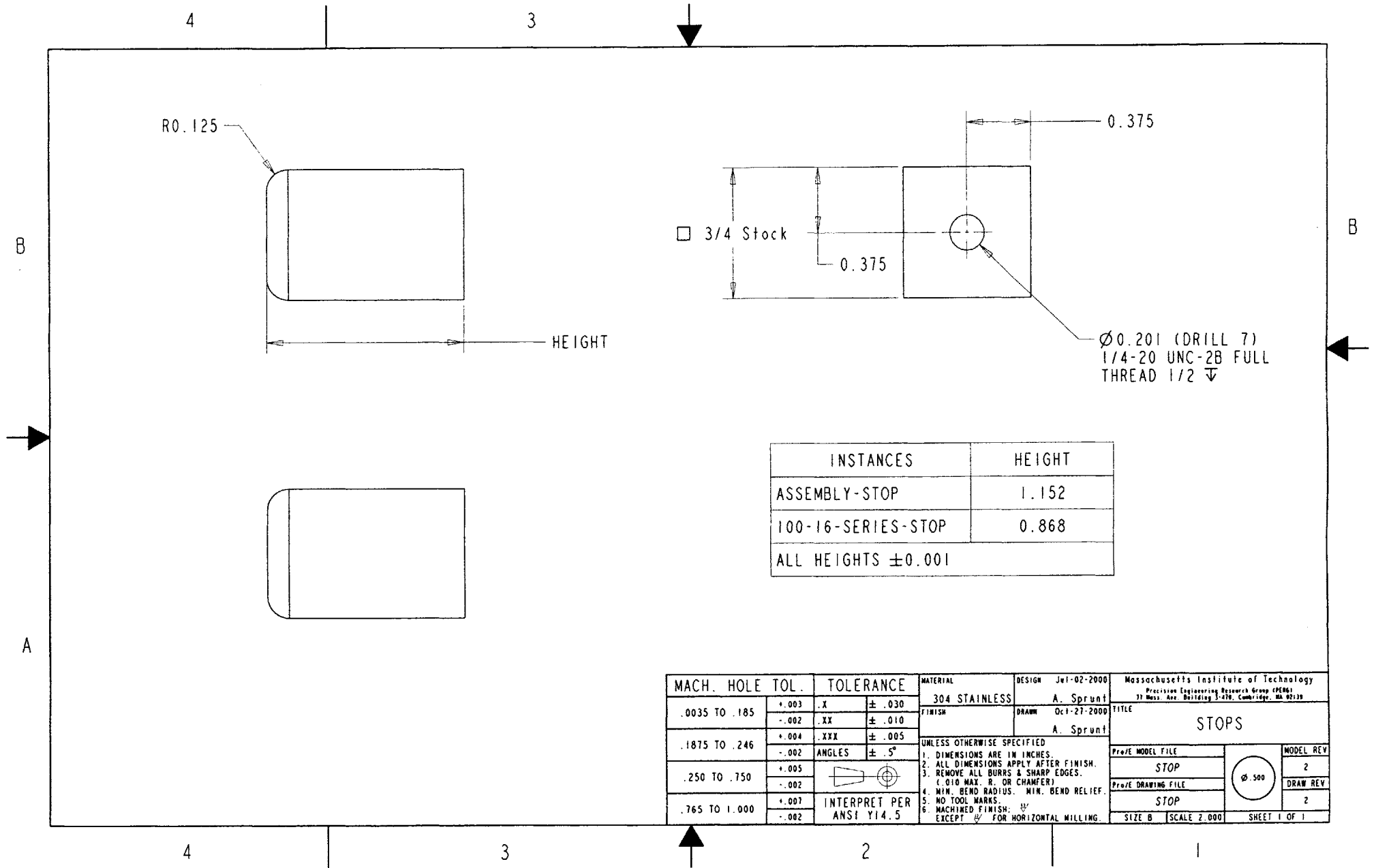

R0.125

□ 3/4 Stock

0.375

0.375

∅0.201 (DRILL 7)
1/4-20 UNC-2B FULL
THREAD 1/2

HEIGHT

INSTANCES	HEIGHT
ASSEMBLY-STOP	1.152
100-16-SERIES-STOP	0.868
ALL HEIGHTS ±0.001	

MACH. HOLE TOL.	TOLERANCE	MATERIAL	DESIGN	Massachusetts Institute of Technology Precision Engineering Research Group (PERG) 37 Mass. Ave. Building 3-470, Cambridge, MA 02139							
.0035 TO .185	+ .003 - .002 .XX ± .030 ± .010	304 STAINLESS	Jul-02-2000 A. Sprunt	TITLE STOPS							
.1875 TO .246	+ .004 - .002 .XXX ± .005 ± .5°	UNLESS OTHERWISE SPECIFIED	Oct-27-2000 A. Sprunt								
.250 TO .750	+ .005 - .002	1. DIMENSIONS ARE IN INCHES. 2. ALL DIMENSIONS APPLY AFTER FINISH. 3. REMOVE ALL BURRS & SHARP EDGES. (.010 MAX. R. OR CHAMFER)	<table border="1"> <tr> <td>PROJE MODEL FILE</td> <td>MODEL REV</td> </tr> <tr> <td>STOP</td> <td>2</td> </tr> <tr> <td>PROJE DRAWING FILE</td> <td>DRAW REV</td> </tr> <tr> <td>STOP</td> <td>2</td> </tr> </table>	PROJE MODEL FILE	MODEL REV	STOP	2	PROJE DRAWING FILE	DRAW REV	STOP	2
PROJE MODEL FILE	MODEL REV										
STOP	2										
PROJE DRAWING FILE	DRAW REV										
STOP	2										
.765 TO 1.000	+ .007 - .002	4. MIN. BEND RADIUS. MIN. BEND RELIEF. 5. NO TOOL MARKS. 6. MACHINED FINISH: $\frac{32}{\sqrt{}} \sqrt{\text{ }}$ EXCEPT $\frac{32}{\sqrt{}} \sqrt{\text{ }}$ FOR HORIZONTAL MILLING.	<table border="1"> <tr> <td>SIZE B</td> <td>SCALE 2.000</td> <td>SHEET 1 OF 1</td> </tr> </table>	SIZE B	SCALE 2.000	SHEET 1 OF 1					
SIZE B	SCALE 2.000	SHEET 1 OF 1									

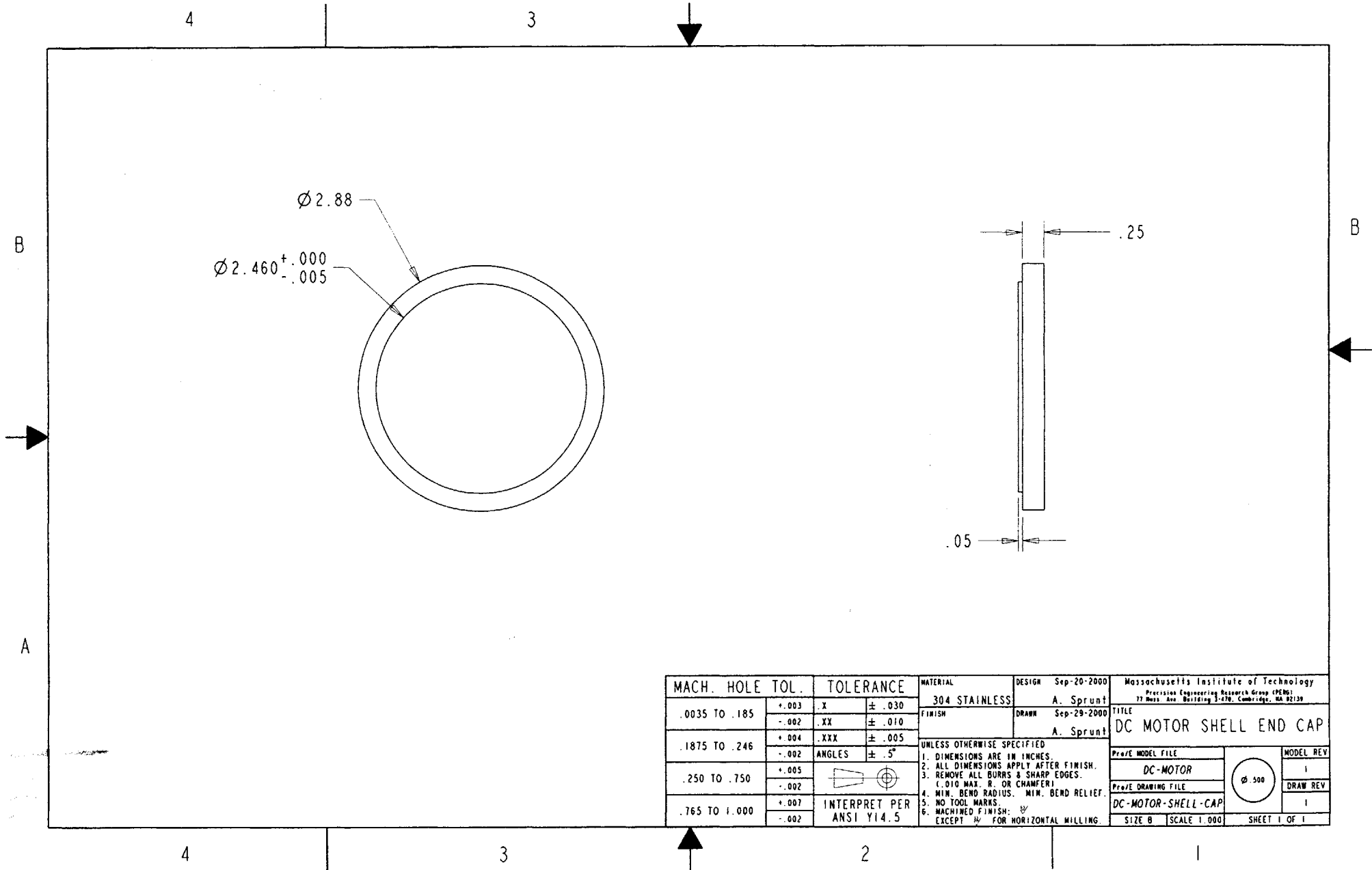

MACH. HOLE TOL.		TOLERANCE		MATERIAL	DESIGN	Massachusetts Institute of Technology Precision Engineering Research Group (PERG) 77 Mass. Ave. Building 3-270, Cambridge, MA 02139	
.0035 TO .185	+ .003	.X	± .030	304 STAINLESS	Sep-20-2000	TITLE	
	- .002	.XX	± .010		A. Sprunt	DC MOTOR SHELL END CAP	
.1875 TO .246	+ .004	.XXX	± .005	FINISH	DRAWN	Pre/E MODEL FILE	
	- .002	ANGLES	± .5°		Sep-29-2000	DC-MOTOR	MODEL REV
.250 TO .750	+ .005		INTERPRET PER ANSI Y14.5	UNLESS OTHERWISE SPECIFIED			
	- .002			1. DIMENSIONS ARE IN INCHES. 2. ALL DIMENSIONS APPLY AFTER FINISH. 3. REMOVE ALL BURRS & SHARP EDGES. (.010 MAX. R. OR CHAMFER) 4. MIN. BEND RADIUS. MIN. BEND RELIEF. 5. NO TOOL MARKS. 6. MACHINED FINISH: Ψ EXCEPT Ψ FOR HORIZONTAL MILLING.			
.765 TO 1.000	+ .007					Pre/E DRAWING FILE	DRAW REV
	- .002					DC-MOTOR-SHELL-CAP	1
						SIZE B	SHEET 1 OF 1

4

3



INNER AND OUTER DIAMETERS
FOR REFERENCE ONLY. PIPE IS
ANSI STANDARD, Ø2.5 NOMINAL

4.5^{+ .01}₀

Ø2.875
Ø2.469

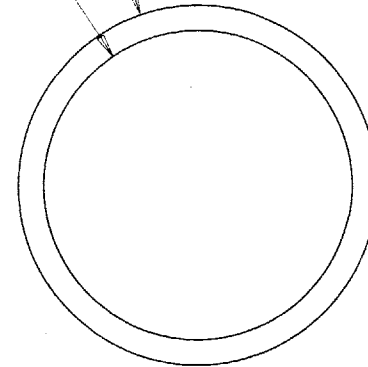

B



SCALE 1.000

B



A

4

3



2

1

MACH. HOLE TOL.	TOLERANCE	MATERIAL	DESIGN	Massachusetts Institute of Technology Precision Engineering Research Group (PERG) 77 Mass. Ave. Building 3-270, Cambridge, MA 02139
.0035 TO .185	+ .003 - .002	STAINLESS STEEL	Sep-20-2000 A. Sprunt	TITLE DC MOTOR SHELL PIPE
.1875 TO .246	+ .004 - .002		FINISH NATURAL A. Sprunt	
.250 TO .750	+ .005 - .002	UNLESS OTHERWISE SPECIFIED 1. DIMENSIONS ARE IN INCHES. 2. ALL DIMENSIONS APPLY AFTER FINISH. 3. REMOVE ALL BURRS & SHARP EDGES. (.010 MAX. R. OR CHAMFER) 4. MIN. BEND RADIUS. MIN. BEND RELIEF. 5. NO TOOL MARKS. 6. MACHINED FINISH: 	PROJE MODEL FILE 25-INCH	MODEL REV 1
.765 TO 1.000	+ .007 - .002		INTERPRET PER ANSI Y14.5	PROJE DRAWING FILE DC-MOTOR-SHELL-PIPE
			SIZE B	SCALE 1.000
			SHEET 1 OF 1	



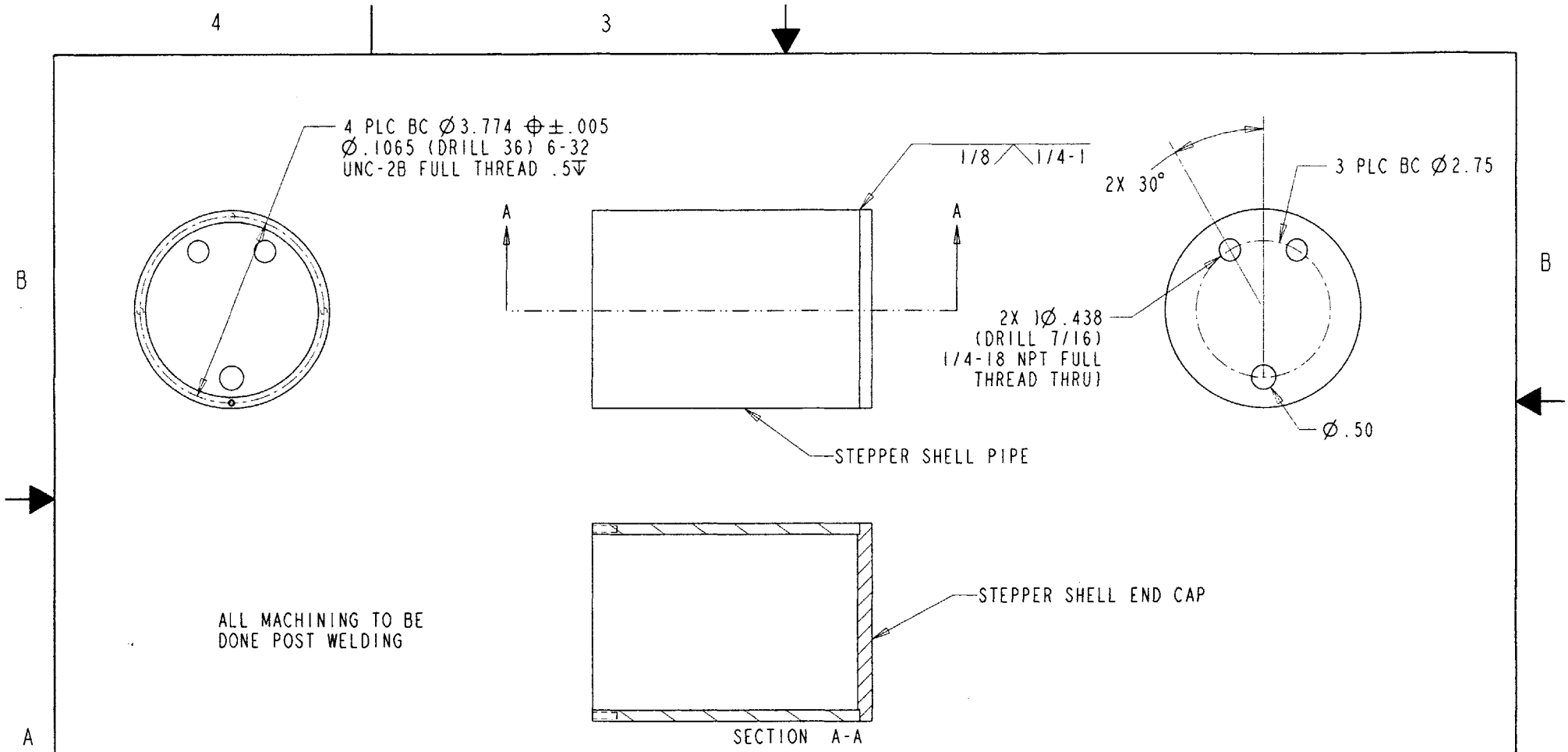

MACH. HOLE TOL.	TOLERANCE	MATERIAL	DESIGN	Massachusetts Institute of Technology
.0035 TO .185	+ .003 - .002	.X .XX	± .030 ± .010	77 Mass. Ave. Building 3-010, Cambridge, MA 02138
.1875 TO .246	+ .004 - .002	.XXX	± .005	
.250 TO .750	+ .005 - .002	ANGLES	± .5°	
.765 TO 1.000	+ .007 - .002	INTERPRET PER ANSI Y14.5		

FINISH	N/A	DESIGN	Sep-20-2000	A. Sprunt	Massachusetts Institute of Technology
FINISH	N/A	DESIGN	Sep-29-2000	A. Sprunt	77 Mass. Ave. Building 3-010, Cambridge, MA 02138
UNLESS OTHERWISE SPECIFIED					TITLE
1. DIMENSIONS ARE IN INCHES.					STEPPER-SHELL
2. ALL DIMENSIONS APPLY AFTER FINISH.					MODEL FILE
3. REMOVE ALL BURRS & SHARP EDGES. (.010 MAX. R. OR CHAMFER)					STEPPER-SHELL
4. MIN. BEND RADIUS. MIN. BEND RELIEF.					MODEL REV
5. NO TOOL MARKS.					1
6. MACHINED FINISH: ∇					DRAW REV
EXCEPT ∇ FOR HORIZONTAL MILLING.					1
SIZE B SCALE 0.500				SHEET 1 OF 1	

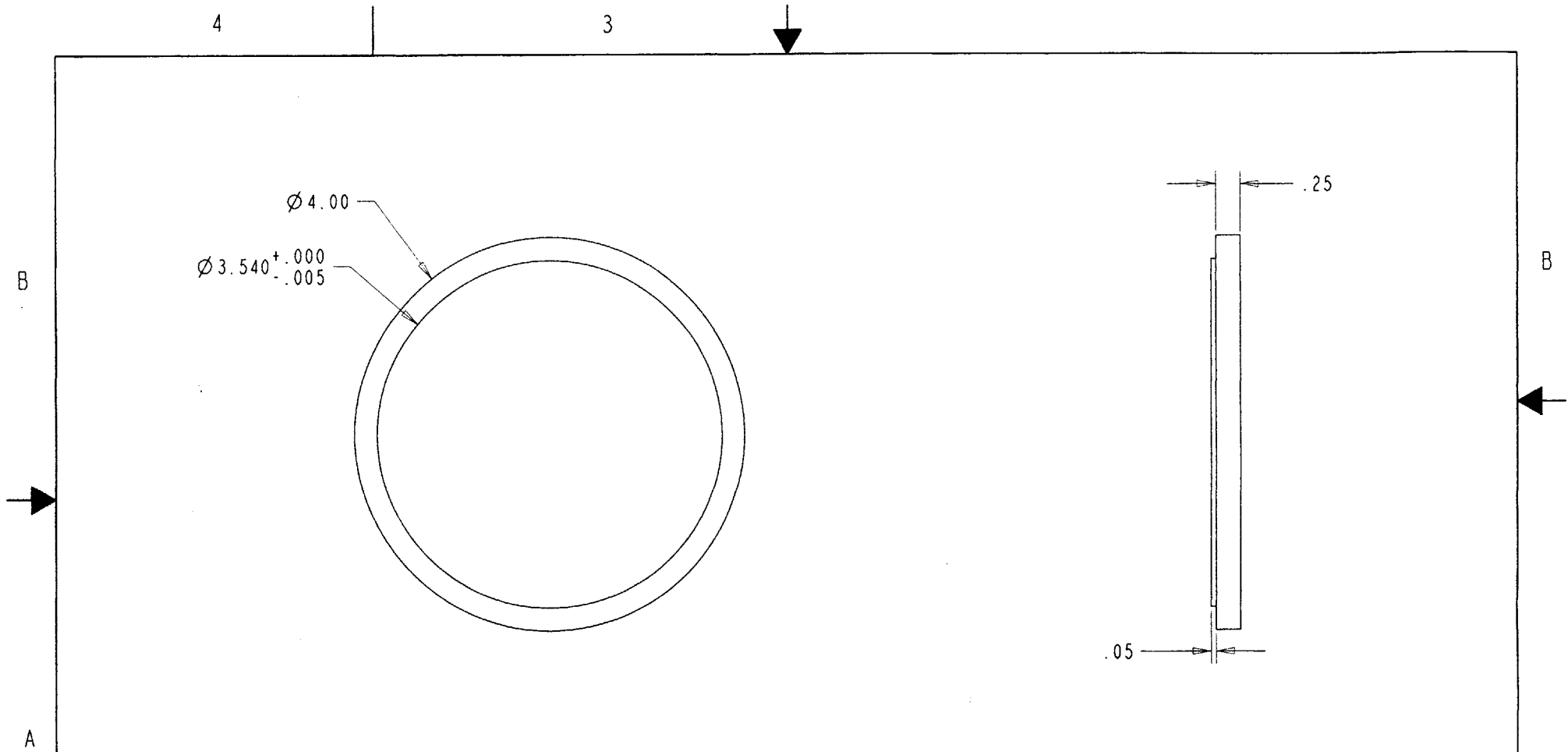

MACH. HOLE TOL.		TOLERANCE		MATERIAL	DESIGN	Massachusetts Institute of Technology Precision Engineering Research Group (PERG) 77 Mass. Ave. Building 3-410, Cambridge, MA 02139	
.0035 TO .185	+ .003	.X	± .030	304 STAINLESS	Sep-20-2000	A. Sprunt	
	-.002	.XX	± .010	FINISH	DRAWN	Sep-29-2000 A. Sprunt	
.1875 TO .246	+ .004	.XXX	± .005	UNLESS OTHERWISE SPECIFIED 1. DIMENSIONS ARE IN INCHES. 2. ALL DIMENSIONS APPLY AFTER FINISH. 3. REMOVE ALL BURRS & SHARP EDGES. (1.010 MAX. R. OR CHAMFER) 4. MIN. BEND RADIUS. MIN. BEND RELIEF. 5. NO TOOL MARKS. 6. MACHINED FINISH: ✓ EXCEPT ✗ FOR HORIZONTAL MILLING.			
	-.002	ANGLES	± .5°				
.250 TO .750	+ .005						
	-.002						
.765 TO 1.000	+ .007	INTERPRET PER ANSI Y14.5					
	-.002						
TITLE				STEPPER-SHELL-END-CAP		STEPPER-MOTOR	
P/FILE MODEL FILE				STEPPER-MOTOR		MODEL REV	
P/FILE DRAWING FILE				STEPPER-END-CAP		DRAW REV	
SIZE B				SCALE 1.000		SHEET 1 OF 1	

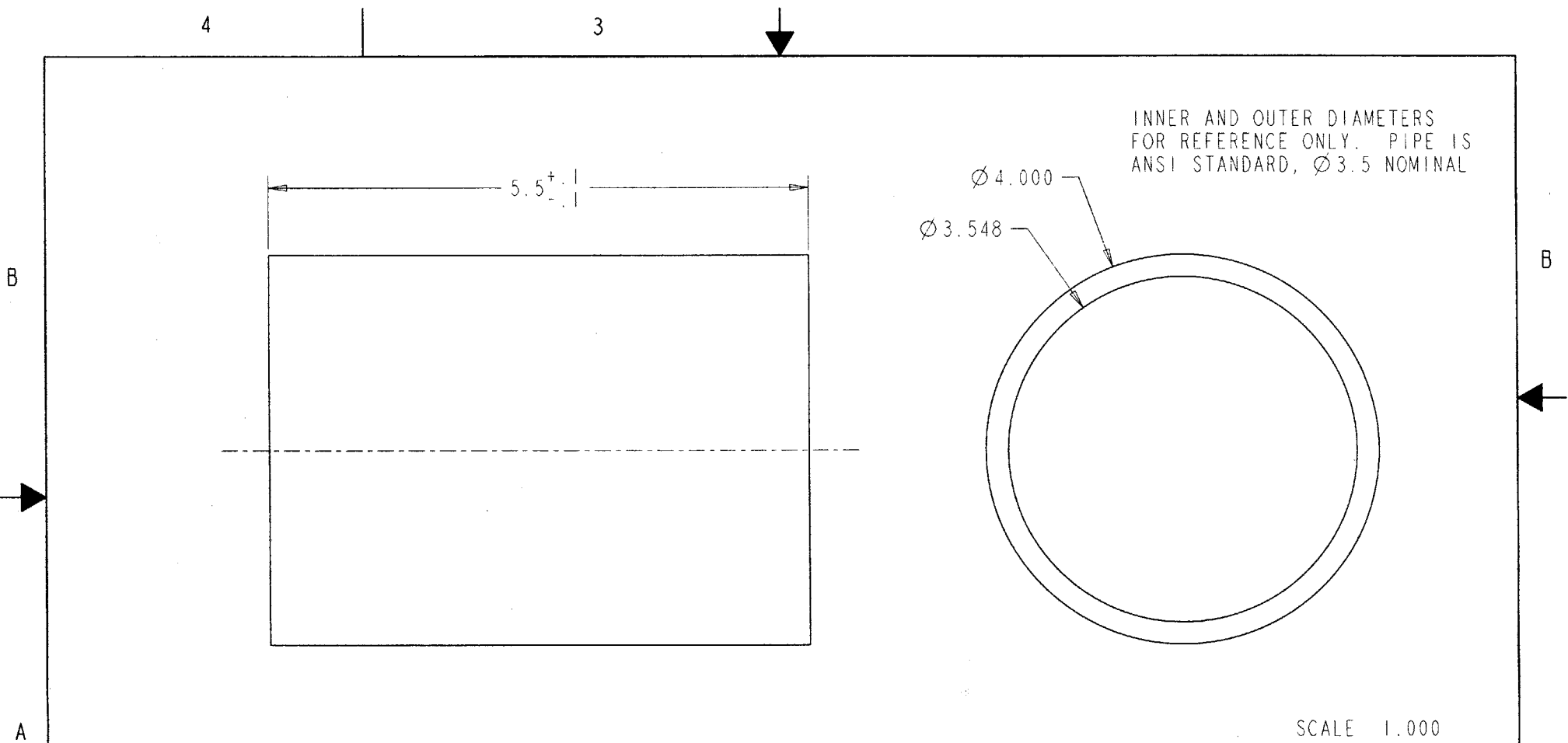

SCALE 1.000

MACH. HOLE TOL.		TOLERANCE		MATERIAL	DESIGN	Massachusetts Institute of Technology											
.0035 TO .185	+.003	.X	± .030	STAINLESS STEEL	Sep-20-2000	Precision Engineering Research Group (PERG)											
	-.002	.XX	± .010	FINISH	A. Sprunt	17 Mass. Ave. Building 3-410, Cambridge, MA 02139											
.1875 TO .246	+.004	.XXX	± .005	NATURAL	DRWN	Sep-29-2000	TITLE										
	-.002	ANGLES	± 5°	A. Sprunt		STEPPER SHELL PIPE											
.250 TO .750	+.005			UNLESS OTHERWISE SPECIFIED													
	-.002			1. DIMENSIONS ARE IN INCHES. 2. ALL DIMENSIONS APPLY AFTER FINISH. 3. REMOVE ALL BURRS & SHARP EDGES. (1.010 MAX. R. OR CHAMFER) 4. MIN. BEND RADIUS. MIN. BEND RELIEF. 5. NO TOOL MARKS. 6. MACHINED FINISH: ∇ EXCEPT ∇ FOR HORIZONTAL MILLING.													
.765 TO 1.000	+.007	INTERPRET PER		<table border="1"> <tr> <td>PROF MODEL FILE</td> <td rowspan="2"> </td> <td>MODEL REV</td> </tr> <tr> <td>35-INCH</td> <td>1</td> </tr> <tr> <td>PROF DRAWING FILE</td> <td rowspan="2"> </td> <td>DRAW REV</td> </tr> <tr> <td>STEPPER-SHELL-PIPE</td> <td>1</td> </tr> </table>				PROF MODEL FILE		MODEL REV	35-INCH	1	PROF DRAWING FILE		DRAW REV	STEPPER-SHELL-PIPE	1
	PROF MODEL FILE		MODEL REV														
35-INCH	1																
PROF DRAWING FILE		DRAW REV															
STEPPER-SHELL-PIPE		1															
	-.002	ANSI Y14.5		<table border="1"> <tr> <td>SIZE B</td> <td>SCALE 1.000</td> <td>SHEET 1 OF 1</td> </tr> </table>				SIZE B	SCALE 1.000	SHEET 1 OF 1							
SIZE B	SCALE 1.000	SHEET 1 OF 1															