

ORIGINAL ARTICLES

Authors alone are responsible for opinions expressed in the contribution and for its clearance through their federal health agency, if required.

MILITARY MEDICINE, 178, 6:596, 2013

A Conceptual Model of the Psychological Health System for U.S. Active Duty Service Members: An Approach to Inform Leadership and Policy Decision Making

Judy Y. Wang, MS; Wiljeana J. Glover, PhD; Alison M. Rhodes, MSW, EdM; Deborah Nightingale, PhD

ABSTRACT The influence of individual-level factors such as pretraumatic risk and protective factors and the availability of unit-level and enterprise-level factors on psychological health outcomes have been previously considered individually, but have not been considered in tandem across the U.S. Military psychological health system. We use the existing literature on military psychological health to build a conceptual system dynamics model of the U.S. Military psychological health system “service-cycle” from accession and deployment to future psychological health screening and treatment. The model highlights a few key observations, challenges, and opportunities for improvement for the system that relate to several topics including the importance of modeling operational demand combined with the population’s psychological health as opposed to only physical health; the role of resilience and post-traumatic growth on the mitigation of stress; the positive and negative effects of pretraumatic risk factors, unit support, and unit leadership on the service-cycle; and the opportunity to improve the system more rapidly by including more feedback mechanisms regarding the usefulness of pre- and post-traumatic innovations to medical leaders, funding authorities, and policy makers.

INTRODUCTION

It has been suggested that the current system for delivering quality psychological care to U.S. Military service members is insufficient to meet projected demand for psychological health services in the near future related to the high rates of mental health problems seen among troops returning from current conflicts.^{1,2} Improving the Military Healthcare System calls for increased coordination along the continuum of clinical care^{3,4} and attention to the various factors that influence mental health across a service member’s possible “service-cycle” (e.g., over time, from accession to final separation from the U.S. Military). Taking a systems approach to this problem would better enable a successful strategy to the delivery of services and improvement of psychological health in the U.S. Military.^{5,6}

A systems approach involves examination of a set of interacting components that collectively have a defined function

and purpose.⁷ Within a systems approach, system dynamics modeling is one method that can be used to better conceptualize these interacting components. System dynamics models are commonly used by senior leaders to assist them in solving organizational problems,⁸ and are commonly used to model health care systems^{9,10}. Here, we use system dynamics to conceptually model the service-cycle. We account for the effects of individual-level (e.g., pretraumatic risk and protective factors for post-traumatic stress disorder [PTSD])^{11,12}, unit-level (e.g., combat team or squadron), and enterprise-level factors (e.g., the Army or Navy Force and Medical Commands; media coverage and/or broader public awareness of PTSD in the military) and how they may impact the potential development or resolution of mental health problems.

There have been several efforts in the civilian and military sectors to model psychological health-related individual- and unit-level factors to improve psychological health outcomes related to post-traumatic stress. Table I summarizes examples of published models using various approaches, from the presentation of conceptual models to quantified, empirical simulation models. These studies present models of a subset of factors, for example, individual-level factors^{13,14} or unit-level factors,^{15,16} but do not combine individual-, unit-, and

Sociotechnical Systems Research Center, Massachusetts Institute of Technology, 77 Massachusetts Avenue, Building E38-642, Cambridge, MA 02139.

This article was presented orally at Institute for Industrial Engineers, Industrial Engineering and Research Conference, Orlando, FL, May 21–25, 2012.

doi: 10.7205/MILMED-D-12-00429

TABLE I. Examples of Previous Psychological Health-Related Analyses

Reference	Application	Description	Limitations
Bates et al, 2010 ¹³	Conceptual military demand-resource model	Accounted for key interactions across demands and factors to predict service member resilience and performance outcomes	Presents a conceptual, not an analytical, model. Does not account for individual-level risk factors that may predispose a service member to experiencing stress reactions.
Morris, et al, 2010 ¹⁴	System dynamics model of stress	Quantitatively assessed the physical and behavioral factors that generate the dynamics of stress in humans	Does not account for individual-level risk factors that may predispose a service member to experiencing stress reactions.
Griffith, 2002 ¹⁵	A multilevel analysis of unit cohesion's relationship to stress and perceived combat readiness	Examined the association between aggregate unit stress and unit cohesion while accounting for individual-level differences	Does not consider other unit factors, e.g., unit leadership.
Bacharach, et al, 2008 ¹⁶	Examined the relationship between the intensity of critical work place incidents experienced by firefighters, resulting stress experienced, and drinking to cope	Found that the adequacy of unit-level performance factors such as training and preparedness factors attenuates the relationships between critical incidents and resulting stress, and stress and drinking to cope	Does not account for individual-level risk factors that may predispose a service member to experiencing stress reactions. Focuses on critical incidences as opposed to the cumulative effect of continuous stressors in the work environment.
Atkinson et al, 2009 ¹⁷	Modeled the relationship between deployment tempo, combat stress, and PTSD prevalence	Accounted for variation in risk across different service member populations, assigning different stress strengths to individual service members and allowing service members to accumulate stress in a stochastic process	Does not account for individual-level risk factors that may predispose a service member to experiencing stress reactions. Focuses on the deployment cycle.

enterprise-level factors. For example, Morris et al¹⁴ present an extensive system dynamics model of how individuals react to stress, accounting for an individual's physical reactions such as cortisol levels as well as an individual's behavioral reactions related to coping. However, they do not account for unit- or enterprise-level supports or resources that may influence the individual's capacity to cope.

We expand on these previous studies by presenting a conceptual model that focuses on the impact of post-traumatic stress and where the majority of service members share a similar service-cycle in the context of Operation Enduring Freedom and Operation Iraqi Freedom. In the model, we consider how individual-level psychological health factors and unit-level and enterprise-level factors positively and negatively influence operational and deployment requirements and psychological health outcomes, e.g., lowered incidence of mental health problems.

This service-cycle model is designed to assist senior leadership in conceptualizing the full continuum of care and to support a more holistic approach to decisions regarding psychological health policies and resource allocation. Conceptualizing the full continuum of care will enable the creation of a strategy to increase coordination of care across the entire service member lifecycle and effective resource allocation across the enterprise, leading to improved psychological health outcomes in the U.S. Military. The model we propose is not intended to be a definitive depiction of the psychological health enterprise. Rather, it serves as a baseline conceptual

model that can be used to engender discussions and inform policy. Conceptual models are based on theoretical and empirical studies, but are not fully quantified (and may be quantified only to the extent data is available). Such conceptual representations are encouraged to develop insight into the emergent behaviors of a system and develop various possible strategies to enhance the system's performance,¹⁸ e.g., operational requirements and psychological health outcomes. The conceptual model we propose could be further quantified in future research to allow strategists to experiment with different change and policy scenarios before implementation.

METHODS

Vensim PLE, system dynamics software capable of developing and analyzing high-level feedback models, was used to build the model. Three sources of data were used to identify model variables and construct the model: published data, a literature review, and interviews. We describe each of these in turn. First, available published data regarding service member deployment and PTSD symptoms,^{19,20} as well as service member accession data from the Accession Medical Standards Analysis & Research Activity 2010 Annual Report²¹ were used to define and quantitatively populate the stocks and flows of service members through the system from accession through treatment. A summary of values is provided in Table II, and unless otherwise specified, all fractional process rates (i.e., fractional accession rate) were

TABLE II. Service-Cycle Stock and Flow Values

Source	Variables	Values	Units
AMSARA 2010 Annual Report ²¹	Military Service Applicants	251,370	Service Members
	Accepted Military Service Members	234,547	
	Applicants Granted Health Waivers ^a	16,823	
	Applicants Eligible for Health Waivers	27,421	
	Accepted Reserve Service Members	45,683	
AMSARA 2010 Annual Report ²¹	Accepted Guard Service Members	56,866	Unitless
	Fractional Accession Rate ^b	0.593	
	Fractional Waiver Approval Rate	0.614	
	Fractional Health Waiver Rejection Rate	0.386	
	Fractional Health-Related Rejection Rate	0.109	
Belasco, 2009 ¹⁸	Fractional Waiver Acceptance Rate ^c	0.394	Service Members
	Service Members Deployed	186,300	
Tanielian and Jaycox, 2008 ¹⁹	Fractional Deployment Rate	0.12	Unitless
	Fractional Diagnosis Rate ^d	0.25	Unitless
	Fractional Onset Rate ^e	0.26	
	Fractional Treatment Rate	0.30	

^aApplicants who receive a permanent medical disqualification are eligible for waivers, in contrast to temporary disqualifications that cover medical conditions such as being overweight.²¹ ^bNo accession rate was given for Guard or Reserves. ^cApplicants who received waivers and accessed within 1 year of application. Regulations state that accessions must occur within 1 year of application, although it is fairly common for applicants to request and be granted a 1-year extension.²¹ For simplification purposes, this model considered all accessions to occur within 1 year as per the regulations. ^dTanielian and Jaycox (2008)¹⁸ found that the diagnosis rate for any given fiscal year ranges from 10% to 31% depending on the study and methods used. Twenty-five percent was chosen as the value used for this model based on a model sensitivity analysis performed predicting an incidental percent change in diagnosed service members between 25% and 31% compared to the range of 10% to 25% (5% vs. 51%). A diagnosis rate of 25% was therefore considered a good estimate of the upper bound of predicted diagnosed service members. ^eThis fractional onset rate is considered underreported, as it only reports the percentage of service members who seek psychological health treatment without being formally diagnosed.¹⁹

held constant across the military service-cycle regardless of service affiliation or deployment status.

Second, individual-, unit-, and enterprise-level factors were identified from a comprehensive review of relevant literature, and added to the model as causal loops. These factors are not intended to be an exhaustive set of factors comprising the service-cycle, but do represent key individual-, unit-, and enterprise-level factors that influence population-wide post-traumatic stress. Because the values of these factors vary greatly depending on the specific service member population, and limited data is available to quantify these factors, these factors were not quantified in the model, but were conceptually modeled to consider their potentially reinforcing or balancing effects on the stock and flow diagram. Table III summarizes the variables explained further in the following sections. The full model (Appendix A) includes additional variables that are summarized in the full model documentation (Appendix B).

Third, six interviews, each lasting approximately 1 hour, were conducted to refine the model. Three interviewees were from the Defense Centers of Excellence for Psychological Health and Traumatic Brain Injury, one interviewee was from the Navy Bureau of Medicine and Surgery, one from the office of the Chairman of the Joint Chiefs of Staff, and another from the Psychological Health Strategic Operations Office of the Office of the Deputy Assistant Secretary of Defense for Force Health Protection and Readiness Programs. Participants were provided with the research purpose and the preliminary model before the interview, and during

the interview they provided feedback and additional insights on the key individual-, unit-, and enterprise-level dynamics that impacted the system. In addition to their current roles, our interviewees were asked to reflect on their past experiences, e.g., as line leadership or mental health providers in a deployed environment. Taken together, these three data sources enabled the construction of the system dynamics model.

Refer to Appendix A for additional details on system dynamics modeling, Appendix B to view the model in its entirety, and Appendix C for the formula documentation. In the sections that follow, we explain various figures that are “screenshots” or segments of the whole model (i.e., Appendix B), including service members’ movement from accession to treatment, individual-level factors, unit-level factors, and enterprise-level factors.

MODEL DISCUSSION

Service Members’ Movement From Accession to Treatment

Figure 1 shows the portion of the model illustrating stocks and flows from accession through treatment. This diagram and associated Table II show various paths that a service member could take from accession to treatment. More specifically, it depicts how many service members are entering the system, why a potential service member would or would not be accepted into the military (e.g., the waiver process), the deployment and return stages, and the diagnoses and treatment stages. This portion of the model could be quantified to

TABLE III. Central Factors of Interest and Definitions

Category	Factor	Description	Example References
Individual-Level Factors	Service Member Stress	Aggregate level of all stress conditions experienced across a health-illness continuum, including PTSD, acute stress reaction, and combat and operational stress reaction	13, 19, 22
	Service Member Resilience	Aggregate ability to which the service member population withstands, recovers, and adapts under challenging conditions	13
	Post-Traumatic Growth	Aggregate experience of feeling transformed and thriving after experiencing stress	23
	Education	Years of education	23-25
	Mental Health History	Prior history or display of criteria for mental health disorders	26
	Family/Social Support	Size and complexity of social network, and perceived emotional sustenance and instrumental assistance from others	11
Unit-Level Factors	Unit Support	Aggregate level of unit cohesion and other protective contextual factors such as collective efficacy	16
Enterprise-Level Factors	Unit Leadership	Aggregate level to which leadership supports and provides group identity	13
	DHP Funding	Funding allocated by DoD Military Health System's Health Affairs for operations and maintenance of health-related programs and services	27
	Line Discretionary Funding	Funding allocated by the individual military service branches, U.S. Army, Navy, Air Force, and Marines for force-fitness-related programs and services, e.g., resilience	28
	Government Pressure	Attention from DoD, Congressional, and other officials, e.g., via legislation	29
	PTSD Awareness	The general U.S. public's recognition of PTSD as a pathology of war, particularly Operation Enduring Freedom/Operation Iraqi Freedom	30
	Pretrauma Innovations	Includes resilience training programs or preventative screening measures	13, 31-33
	Post-Trauma Innovations	Advances in measures, programs, and services to detect and treat post-traumatic stress and related problems	34
	Pretrauma Screening Stringency	Includes advancements to psychological health screening mechanisms	32

show the number of service members who are at any given stage at a particular time. Furthermore, one can see the attrition rate over time, as service members leave the system via a health waiver rejection, being honorably or dishonorably discharged, or completing treatment. Operational demand,

a key factor influencing service member movement from accession to treatment, particularly with regards to deployment rate, is also depicted; with greater operational demand (the demand for additional service members as dictated by operational needs and combat intensity), it is necessary to

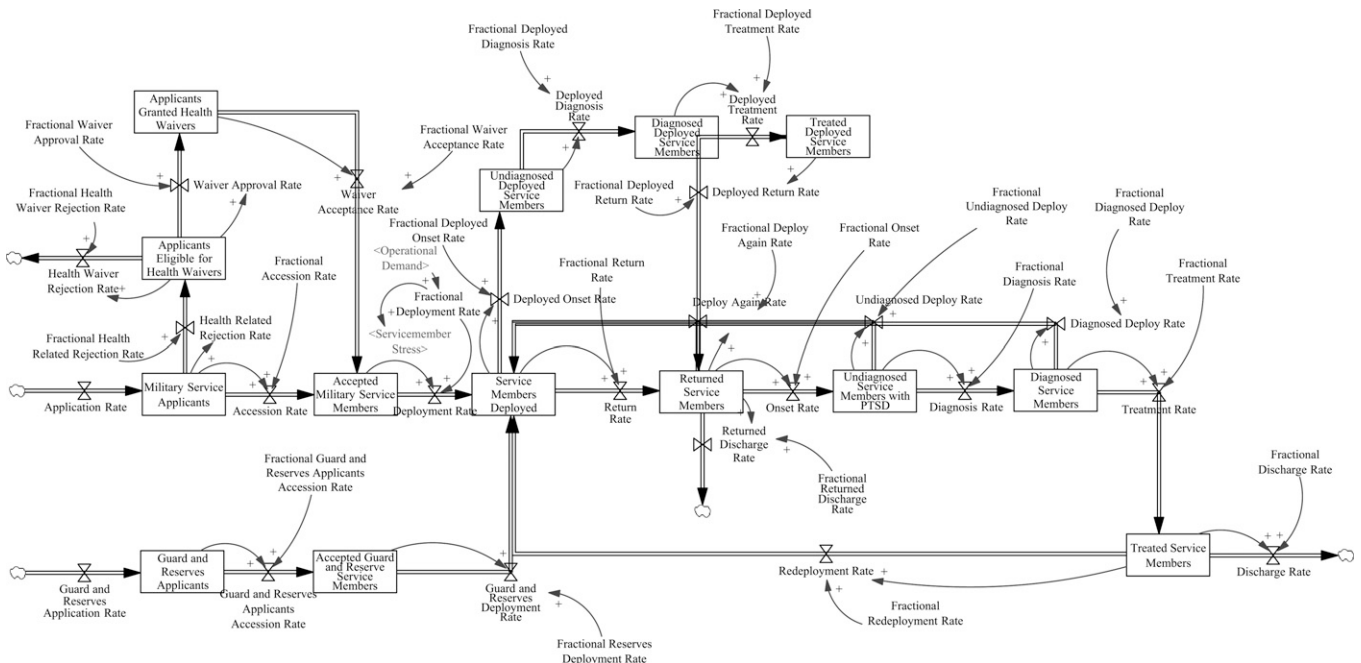

FIGURE 1. Service-cycle stock and flow diagram.

increase the deployment rate and vice versa. A senior leader could use this diagram to better conceptualize levers of change. For instance, by increasing the accession rate via different screening tools or policies,³⁵ more service members could be available for deployment, thus lessening the stress associated with combat exposure on any given service member since more available service members could reduce the number of redeployments or increase dwell time.

Individual-Level Factors

Individual-level factors interact with the movement of the service members from accession to treatment to influence service member mental health and their need to seek services. There is a direct relationship between deployment rate and service member stress, and in turn stress influences the number of service members reporting an onset of mental health problems in the short term. The balancing loop in Figure 2 shows the portion of the model depicting individual-level factors: the aggregate levels of service member stress, resilience, and post-traumatic growth in the active duty service member population and pretraumatic risk and protective factors (e.g., mental health history, education) that have been found to impact post-traumatic stress.

Recent literature describes service member stress as a health-illness continuum to encourage early recognition of stress behaviors and early access to preclinical and clinical services when needed.^{13,22} For example, Nash³⁶ presents the U.S. Navy’s Combat and Operational Stress Control continuum paradigm that spans stress responses and outcomes “from adaptive coping and full readiness (color-coded green as the “ready” zone), to mild and reversible distress or loss of function (the yellow “reacting” zone), to more severe and

persistent distress or loss of function (the orange “injured” zone), to clinical mental disorders arising from stress and unhealed stress injuries (the red “ill” zone).” Our model adopts this view of stress to not only include formally diagnosed PTSD,³⁷ but as a rate that reflects a continuum from health to illness. Service member resilience, defined as the ability to withstand, recover, and adapt under challenging conditions,^{38,39} is currently considered by the U.S. Military as critical to managing service member stress.^{11,13,25} In addition, the literature suggests that the experience of distress can lead to post-traumatic growth, i.e., perceived positive changes in one’s sense of self, outlook on life, and/or relationships.^{23,40} It has been suggested that post-traumatic growth may facilitate service members’ ability to cope with combat-related stress, and over time individuals who experience post-traumatic growth may become more resilient.^{41,42}

The relationship between service member stress, resilience, and post-traumatic growth can be modeled as a balancing loop. As depicted in Figure 2, greater resilience is associated with lesser stress. In addition, based on theoretical discussions suggesting that resilience may be expected to relate to the tendency to perceive benefits in the aftermath of trauma,^{41,42} the balancing loop also illustrates that post-traumatic growth may be positively associated with service member resilience. It is important to note that the relationship between stress, growth, and resilience is likely more complex than a direct linear relationship. For instance, in the immediate aftermath of a traumatic event, post-traumatic growth may serve as a coping strategy to avoid one’s suffering, but over time post-traumatic growth may become more constructive leading to genuine positive changes and increased resilience.⁴³ Our model reflects this complexity such that service member

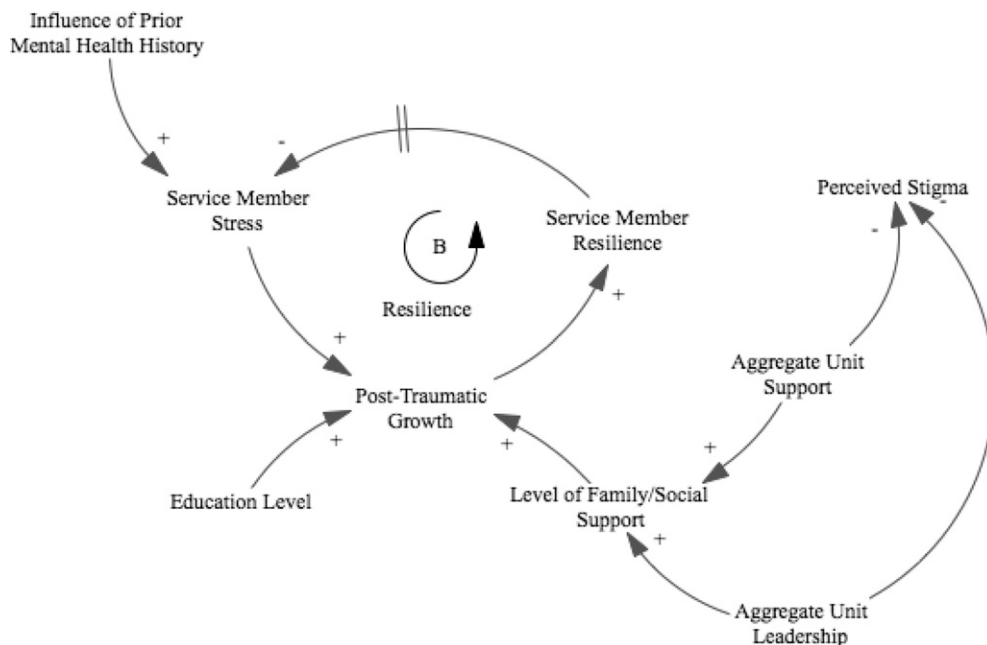

FIGURE 2. Impact of individual- and unit-level factors.

resilience decreases initially because of service member stress but builds over time with post-traumatic growth as the service member learns to cope and deal with stress.

Service member stress, resilience, and post-traumatic growth are also impacted by the individual-level pretraumatic risk and protective factors. These factors include socio-demographic variables (age, education, gender, and income), social support, and previous psychological distress.^{23,24,44} We focus on three representative pretraumatic factors that are prominent in the literature and monitored by the Department of Defense (DoD), namely education (e.g., Armed Services Vocational Aptitude Battery scores before service), mental health history (e.g., number of psychological health-related diagnoses before service), and family/social support.^{11,12} Factors such as high levels of family/social support and education serve to mitigate service member stress and build their resilience.¹¹ The inclusion of family/social support as an individual-level factor as opposed to a unit-level factor is not to suggest that interpersonal and family dynamics are a sum of each individual's level of support, but rather that the extent of family/social support will likely vary by individual rather than by unit.

Unit-Level Factors

Unit-level factors, including unit support and unit leadership, interact with individual-level factors to influence service members' mental health. Unit-level factors, namely unit leadership and unit support are also included in Figure 2. Unit leadership is considered a key resource in the U.S. Military, as it pervades both the morale and effectiveness of the unit, affecting all aspects of a unit's operational routine.¹³ Unit support has been emphasized as a key external resource for building individual service member resilience, as it provides external support via friendships and group identity for service members as the unit performs its mission.¹³ Although we recognize that there are other unit-level factors (e.g., personnel, information systems) that can influence mental health of service members, these factors have been explored elsewhere⁴⁵; therefore, we focus on socially relevant factors that are less often modeled, yet essential to mental health.^{13,25}

Our model illustrates the interaction between individual- and unit-level factors. For example, higher levels of unit leadership and unit support may mitigate lower levels of family/social support throughout the service-cycle. This implies that, via supportive relationships between service members and their peers and leadership, prior unsupportive interpersonal relationships may be less influential on psychological health outcomes of the population. The model also suggests that high levels of unit leadership and unit support may mitigate the stigma previously associated with seeking psychological health care and vice versa.¹⁹

Enterprise-Level Factors

Three key categories of enterprise-level factors are accounted for in the model, including sources of funding, broader social

and institutional pressures, and pre- and post-trauma innovations. Within the DoD, there are two major sources of funding for personnel, health prevention, resilience training programs, screenings, treatment, and research. First, the Military Health System is responsible for health policy and allocating government-mandated Defense Health Program (DHP) funding to provide programs and services.²⁷ Second, each military service has what we term line discretionary funding to provide supplementary programs and services for active duty service members.²⁸ In addition to these funding sources, several social and institutional pressures frame PTSD as a significant problem among U.S. service members, including government pressure (i.e., attention from DoD, Congressional, and other officials), PTSD awareness (i.e., the public's awareness of PTSD), and media coverage of PTSD among U.S. service members.

Pre- and post-trauma innovations are influenced by these funding sources and broader social and institutional pressures. Pretrauma innovations include, for example, resilience training programs or preventative screening measures. These innovations may reduce the impact of deployment-related stressors. Post-trauma innovations are advances in measures, programs, and services to detect and treat post-traumatic stress and related problems. The following presents the military preventative screening process to illustrate the influence of enterprise-level factors.

Figure 3 shows the current state dynamics of military preventative screening for PTSD and related conditions, and accounts for the funding sources and broader social and institutional pressures that influence such innovations.

When the stock of diagnosed service members increases, there is also an increase in PTSD awareness both within the military and in the general public, which results in an increase of government pressure through legislation like the National PTSD Awareness Day,²⁹ and eventually through additional DHP funding, and line discretionary funding.⁴ This increase in funding can be funneled toward pretrauma innovations, e.g., improved psychological health screening mechanisms.³² If actual usefulness of pretrauma innovations increases, the more likely they will be used, and pretrauma screening stringency should increase as a result. This also increases the health-related rejection rate, decreasing the accession rate, and eventually decreasing the number of service members who require treatment for PTSD. This represents an inherent trade-off between the number of diagnosed service members and the number of accepted military service members. Time delays in this balancing loop occur because of the relationship between onset rate, diagnosis rate, PTSD awareness, government pressure to enact action for providing services for returning service members and the subsequent legislation enacted to provide funding for these services via DHP and line discretionary funding.

In addition, the operational mechanisms for funding programs such as the DHP often increase in complexity as execution powers are held by external agents such as the Office of

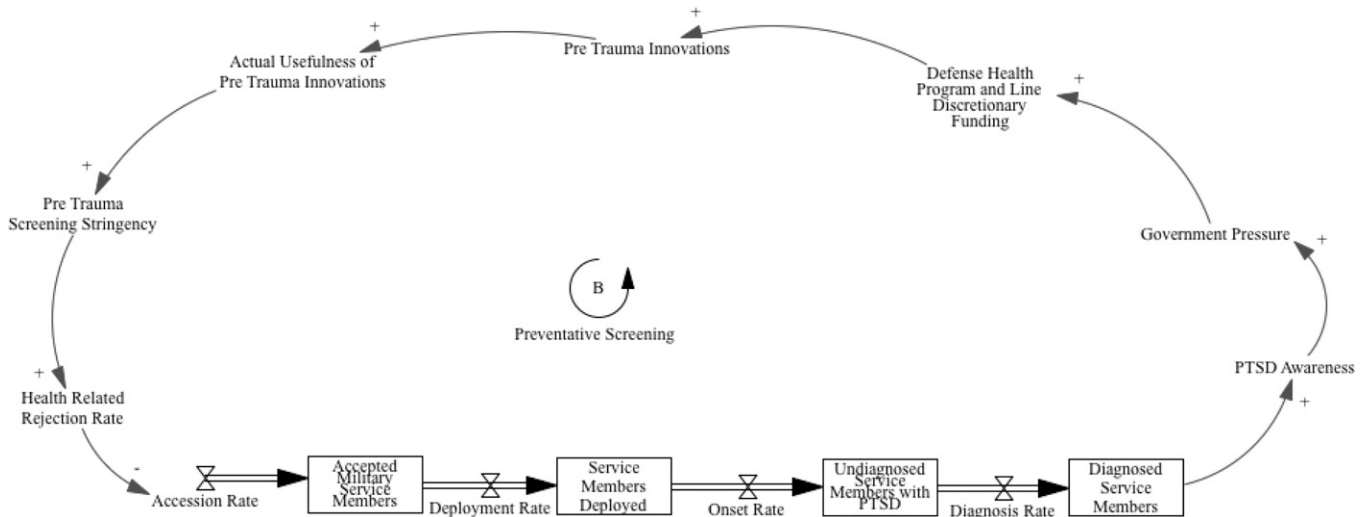

FIGURE 3. Example of enterprise-level factors—preventative screening dynamics.

the Assistant Secretary of Defense for Health Affairs. Hence, the model does not link actual usefulness of pretrauma innovations to DHP funding and line discretionary funding directly, but rather through several other variables. As this instance demonstrates, the model can be useful not just for showing what links exist between variables, but also which links are delayed, or even lacking—links that would be useful for system improvement and would encourage more timely, direct feedback, particularly to military medical departments with analysis in conjunction with the Defense Centers of Excellence and recommendations made to the Office of the Assistant Secretary of Defense for Health Affairs.

IMPLICATIONS FOR SENIOR LEADERSHIP AND LIMITATIONS

Based on our conceptual system dynamics model, there are several complexities of enacting change to the U.S. Military psychological health system to inform senior leaders' decision making. First, our model simultaneously accounts for multiple stages and levels of complexity of the psychological health system from accession to treatment, enabling senior leaders to consider enacting change at various points. For example, in our discussion of the influence of operational demand on the system (Fig. 1), we discussed how senior leaders have multiple levers to meet the needed demand, including increasing the accession rate, the deployment rate, and the treatment rate. In practice, these rates can be changed by different policy-making organizations, e.g., accession rate is controlled by Accession Policy, the direct orders to increase the deployment rate are made by the individual branches of the U.S. Military, and the treatment rate can be changed by Health Affairs (e.g., by funding more providers).⁶ Insight into these multiple stages can inform current efforts to create “systems of care” or “patient pathways” to not only include clinical stages, but also to account for stages as early as

deployment or accession as contextual or input states to these systems or pathways.

Second, there are inherent time delays in the psychological health system, causing additional complexity in decision making. For example, in our discussion of improved preventative screening mechanisms as a pretrauma innovation (Fig. 3), there is a delay from onset rate and diagnosis rate to PTSD awareness and government pressure to enact action and subsequent legislation regarding PTSD. Initiatives such as public service awareness campaigns and increased communication between military leadership and lawmakers may assist in counteracting these time delays and enact even more timely policies. Third, several measurement challenges were identified during the modeling process that also have implications for the system of care. This model uses the available literature to indicate relationships and values where available, and interview data allowed us to account for complexities that the quantitative data could not provide. Future research should be conducted to further quantify these variables and relationships. We do not expect, even with additional quantitative data, that such a model can truly capture all data elements essential to the complex issue of mental health. However, further quantification would provide senior leaders with more data-driven representations to inform their thinking regarding psychological health policy decisions.

There are also limitations associated with our model. First, as a research method, system dynamics studies high-level effects and aggregates population differences into a continuous function, allowing conclusions to be made about a population at large. However, this means that any individual differences and data outliers are lost. These differences include temporality (e.g., 1 year versus multiple years in service), condition (e.g., PTSD vs. depression), deployment location (e.g., Middle East vs. South Korea), deployment rate (e.g., one vs. multiple deployments), and profession (e.g., by

rank and functional role). Future models depicting different subsets of the military population, different deployment locations, etc. would address this limitation. Also, this conceptual system dynamics model was developed with a limited interview set and with retrospective input from interviewees. Additional interviews with other service members from the line and medical settings, as well as with military psychological health providers, strategic analysts, and decision makers, would provide further information for model development and validation. In addition, this work could drive the expansion of the system dynamics model in this work into a collaborative model for future research in the area of military health care delivery.

ACKNOWLEDGMENTS

We acknowledge the support of the Post-Traumatic Stress Innovations Research Team at the Massachusetts Institute of Technology (Tenley Albright, Jayakanth Srinivasan, Mehmet Erkan Ceyhan, Jorge Fradinho, John Carroll, Donna Rhodes, Ken Kaplan, Ellie Carlough, and Paula Buick) as well as staff at the Defense Center of Excellence for Traumatic Brain Injury and Psychological Health for comments on an earlier draft of this manuscript. This effort was funded through FA 7014-09-D-0011 Task Order 0002: Applying Lean to Mental Health Services Enterprise.

APPENDIX A: AN OVERVIEW OF SYSTEM DYNAMICS MODELING

System dynamics involves two different tools for modeling a complex system: causal loop diagrams and stock and flow diagrams. Causal loop diagrams illustrate a causal relationship between two or more variables and can demonstrate nonlinear relationships and feedback mechanisms; positive or reinforcing loops amplify whatever is happening in a system while negative or balancing loops counteract and oppose change.⁸ In addition, time delays can be accounted for in causal loops as indicated by two parallel lines that bisect the linking arrow between two variables. For example, Figure A1 illustrates a positive causal relationship between birth rate and population—as the birth rate increases, population increases (reinforcing loop); as the death rate increases, population

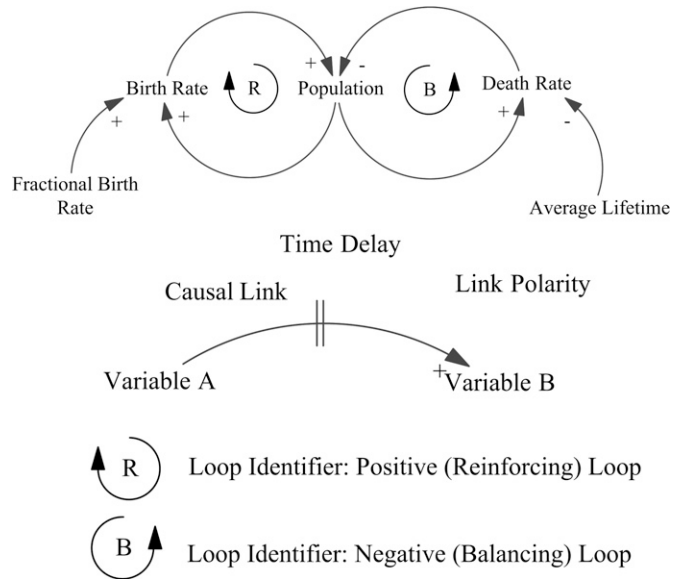

FIGURE A1. Example of causal loop diagram. Adapted from Sterman (2000).⁸

always decreases (balancing loop). Because there are time delays for the aggregate population between birth and death, the figure denotes a time delay between the two variables.

Causal loop and stock and flow diagrams come together in a full system dynamics model to depict processes and delays, and various resources that impact the system. In this study, we use stock and flow diagrams to depict how service members move through the system from accession to treatment (Fig. A2). We use causal loop diagrams to show the social and financial factors that influence service member flow through the system.

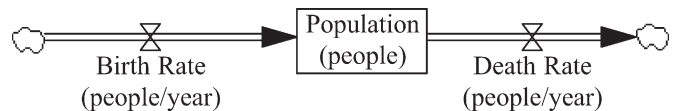
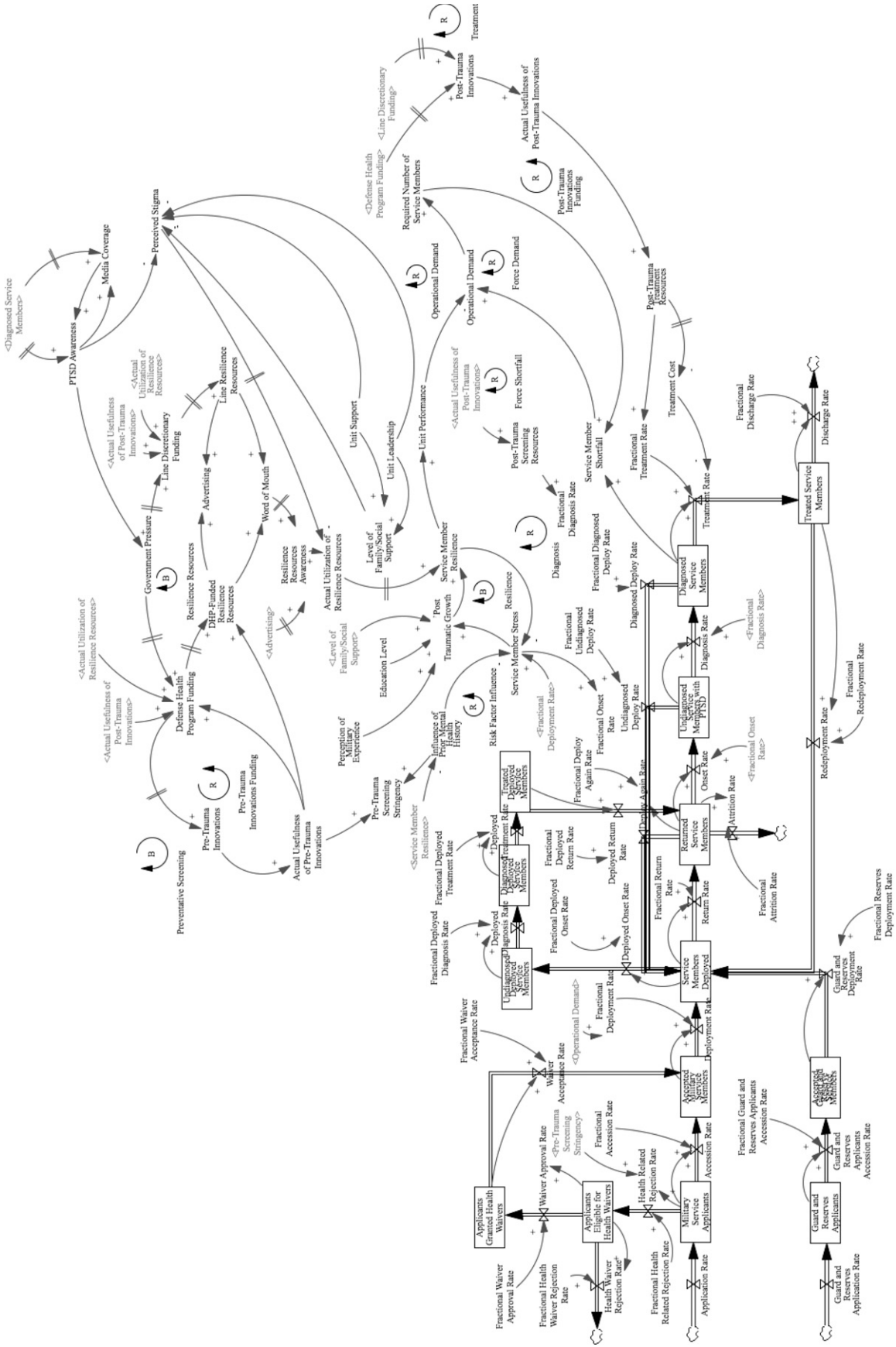

FIGURE A2. Example of stock and flow diagram. Adapted from Sterman (2000).⁸

APPENDIX B: A SYSTEM DYNAMICS MODEL OF THE MILITARY PSYCHOLOGICAL HEALTH ENTERPRISE⁶



APPENDIX C: EQUATION DOCUMENTATION

- (1) Accepted Guard and Reserve Service Members = Integral (INTEG) (Guard and Reserves Deployment Rate + Guard and Reserves Applicants Accession Rate, 102,549) Units: Service Members
- (2) Accepted Military Service Members = INTEG (Accession Rate + Waiver Acceptance Rate – Deployment Rate, 234,547) Units: Service Members
- (3) Accession Rate = Fractional Accession Rate × Military Service Applicants; Units: Service Members/Year
- (4) Applicants Eligible for Health Waivers = INTEG – (Health Waiver Rejection Rate – Waiver Approval Rate + Health-Related Rejection Rate, 27,421) Units: Service Members
- (5) Applicants Granted Health Waivers = INTEG – (Waiver Acceptance Rate + Waiver Approval Rate, 234,547) Units: Service Members
- (6) Application Rate = 251,370; Units: Service Members/Year
- (7) Deploy Again Rate = Fractional Deploy Again Rate × Returned Service Members; Units: Service Members
- (8) Deployed Diagnosis Rate = Fractional Deployed Diagnosis Rate × Undiagnosed Deployed Service Members; Units: Service Members/Year
- (9) Deployed Onset Rate = Service Members Deployed × Fractional Deployed Onset Rate; Units: Service Members/Year
- (10) Deployed Return Rate = Fractional Deployed Return Rate × Treated Deployed Service Members; Units: Service Members/Year
- (11) Deployed Treatment Rate = Diagnosed Deployed Service Members × Fractional Deployed Treatment Rate; Units: Service Members/Year
- (12) Deployment Rate = Fractional Deployment Rate × Accepted Military Service Members; Units: Service Members/Year
- (13) Diagnosed Deploy Rate = Diagnosed Service Members × Fractional Diagnosed Deploy Rate; Units: Service Members/Year
- (14) Diagnosed Deployed Service Members = INTEG (Deployed Diagnosis Rate – Deployed Treatment Rate, 0) Units: Service Members
- (15) Diagnosed Service Members = INTEG (Diagnosis Rate – Diagnosed Deploy Rate – Treatment Rate, 0) Units: Service Members
- (16) Diagnosis Rate = Fractional Diagnosis Rate × Undiagnosed Service Members With PTSD; Units: Service Members/Year
- (17) Discharge Rate = Treated Service Members × Fractional Discharge Rate; Units: Service Members/Year
- (18) Final Time = 100; Units: Year the Final Time for the Simulation
- (19) Fractional Accession Rate = 0.593; Units: Service Members/Service Members/Year
- (20) Fractional Deploy Again Rate = 0.12; Units: 1/Year
- (21) Fractional Deployed Diagnosis Rate = 0.25; Units: 1/Year
- (22) Fractional Deployed Onset Rate = $-0.122 \times \text{Unit Support} + 0.56$; Units: 1/Year
- (23) Fractional Deployed Return Rate = 0.12; Units: 1/Year
- (24) Fractional Deployed Treatment Rate = 0.3; Units: 1/Year
- (25) Fractional Deployment Rate = 0.12; Units: 1/Year
- (26) Fractional Diagnosed Deploy Rate = 0.12; Units: 1/Year
- (27) Fractional Diagnosis Rate = 0.25; Units: 1/Year
- (28) Fractional Discharge Rate = 0.17; Units: 1/Year
- (29) Fractional Guard and Reserves Applicants Accession Rate = 0.862; Units: 1/Year
- (30) Fractional Health-Related Rejection Rate = 0.108; Units: 1/Year
- (31) Fractional Health Waiver Rejection Rate = 0.386; Units: 1/Year
- (32) Fractional Onset Rate = $-0.122 \times \text{Unit Support} + 0.56$; Units: 1/Year
- (33) Fractional Redeployment Rate = 0.12; Units: 1/Year
- (34) Fractional Reserves Deployment Rate = 0.12; Units: 1/Year
- (35) Fractional Return Rate = 0.12; Units: 1/Year
- (36) Fractional Returned Discharge Rate = 0.17; Units: 1/Year
- (37) Fractional Treatment Rate = 0.3; Units: 1/Year
- (38) Fractional Undiagnosed Deploy Rate = 0.12; Units: 1/Year
- (39) Fractional Waiver Acceptance Rate = 0.394 Units: 1/Year
- (40) Fractional Waiver Approval Rate = 0.614; Units: 1/Year
- (41) Guard and Reserves Applicants = INTEG – (Guard and Reserves Applicants Accession Rate + Guard and Reserves Application Rate, 102549) Units: Service Members
- (42) Guard and Reserves Applicants Accession Rate = Fractional Guard and Reserves Applicants Accession Rate × Guard and Reserves Applicants; Units: Service Members/Year
- (43) Guard and Reserves Application Rate = 102549; Units: Service Members/Year
- (44) Guard and Reserves Deployment Rate = Accepted Guard and Reserve Service Members × Fractional Reserves Deployment Rate; Units: Service Members/Year
- (45) Health-Related Rejection Rate = Fractional Health-Related Rejection Rate × Military Service Applicants; Units: Service Members/Year
- (46) Health Waiver Rejection Rate = Fractional Health Waiver Rejection Rate × Applicants Eligible for Health Waivers; Units: Service Members/Year
- (47) Initial Time = 0; Units: Year, the Initial Time for the Simulation.
- (48) Military Service Applicants = INTEG – (Accession Rate – Health-Related Rejection Rate + Application Rate, 353,919) Units: Service Members
- (49) Onset Rate = Fractional Onset Rate × Returned Service Members; Units: Service Members/Year
- (50) Redeployment Rate = Fractional Redeployment Rate × Treated Service Members; Units: Service Members/Year
- (51) Return Rate = Fractional Return Rate × Service Members Deployed; Units: Service Members/Year
- (52) Returned Discharge Rate = Returned Service Members × Fractional Returned Discharge Rate; Units: Service Members/Year
- (53) Returned Service Members = INTEG (Deployed Return Rate + Return Rate – Deploy Again Rate – Onset Rate – Returned Discharge Rate, 0) Units: Service Members
- (54) SAVEPER = TIME STEP; Units: Year [0,?], the Frequency With Which Output is Stored
- (55) Service Members Deployed = INTEG (Deployment Rate + Diagnosed Deploy Rate + Guard and Reserves Deployment Rate + Redeployment Rate + Undiagnosed Deploy Rate – Deployed Onset Rate – Return Rate, 186,300) Units: Service Members
- (56) TIME STEP = 1; Units: Year [0,?], the Time Step for the Simulation
- (57) Treated Deployed Service Members = INTEG – (Deployed Return Rate + Deployed Treatment Rate, 0) Units: Service Members
- (58) Treated Service Members = INTEG (Treatment Rate – Redeployment Rate – Discharge Rate, 0) Units: Service Members
- (59) Treatment Rate = Diagnosed Service Members × Fractional Treatment Rate; Units: Service Members/Year
- (60) Undiagnosed Deploy Rate = Fractional Undiagnosed Deploy Rate × Undiagnosed Service Members With PTSD; Units: Service Members/Year
- (61) Undiagnosed Deployed Service Members = INTEG (Deployed Onset Rate – Deployed Diagnosis Rate, 0) Units: Service Members
- (62) Undiagnosed Service Members With PTSD = INTEG (Onset Rate – Undiagnosed Deploy Rate – Diagnosis Rate, 0) Units: Service Members
- (63) Unit Support = 2.447; Units: Dimensionless
- (64) Waiver Acceptance Rate = Applicants Granted Health Waivers × Fractional Waiver Acceptance Rate; Units: Service Members/Year
- (65) Waiver Approval Rate = Fractional Waiver Approval Rate × Applicants Eligible for Health Waivers; Units: Service Members/Year

REFERENCES

1. Sundin J, Fear NT, Iversen A, Rona RJ, Wessely S: PTSD after deployment to Iraq: conflicting rates, conflicting claims. *Psychol Med* 2010; 40(3): 367–82.
2. Defense Health Board: An achievable vision. Report of the Department of Defense Task Force on Mental Health. Falls Church, VA, Defense Health Board, 2007. Available at <http://www.health.mil/dhb/mhtf/mhtf-report-final.pdf>; accessed September 25, 2012.
3. Jackonis MJ, Deyton L, Hess WJ: War, its aftermath, and U.S. health policy: toward a comprehensive health program for America's military personnel, veterans, and their families. *J Law Med Ethics* 2008; 36: 677–89.

4. U.S. Department of Defense Task Force on the Future of Military Health Care: Final report of the Department of Defense Task Force on the Future of Military Health Care. Washington, DC, U.S. Department of Defense, 2007. Available at http://www.dcoe.health.mil/Content/Navigation/Documents/103-06-2-Home-Task_Force_FINAL_REPORT_122007.pdf; accessed September 25, 2012.
5. Burnam MA, Meredith LS, Tanielian T, Jaycox LH: Mental health care for Iraq and Afghanistan War veterans. *Health Affairs* 2009; 28: 771–82.
6. Wang JYH: The Impact of Individual-, Unit-, and Enterprise-level Factors on Psychological Health Outcomes: A System Dynamics Study of the U.S. Military. Massachusetts Institute of Technology, Master's thesis, Cambridge, MA, 2011. Available at <http://hdl.handle.net/1721.1/68447>; accessed September 25, 2012.
7. de Weck OL, Daniel Roos D, Magee CL: *Engineering Systems: Meeting Human Needs in a Complex Technological World*. Cambridge, MA, The MIT Press, 2011.
8. Sterman JD: *Business Dynamics: Systems Thinking and Modeling for a Complex World*. Boston, MA, McGraw-Hill Companies, 2000.
9. Homer JB, Hirsch GB: System dynamics modeling for public health: background and opportunities. *Am J Public Health* 2006; 96(3): 19–25.
10. Wolstenholme E: A patient flow perspective of U.K. Health Services: exploring the case for new “intermediate care” initiatives. *Sys Dyn Rev* 1999; 15(3): 253–71.
11. King DW, King LA, Foy DW, Keane TM, Fairbank JA: Posttraumatic stress disorder in a national sample of female and male Vietnam veterans: risk factors, war-zone stressors, and resilience-recovery variables. *J Abnorm Psychol* 1999; 108(1): 164–70.
12. Phillips CJ, LeardMann CA, Gumbs GR, Smith B: Risk factors for posttraumatic stress disorder among deployed US male marines. *BMC Psychiatry* 2010; 2(10): 52.
13. Bates M, Bowles S, Hammermeister J, Stokes C, Pinder E: Psychological fitness. *Mil Med* 2010; 175(8): 21–38.
14. Morris A, Ross W, Uliuru M: A System Dynamics View of Stress: Towards Human-Factor Modeling with Computer Agents. Paper presented at IEEE International Conference on Systems, Man and Cybernetics, Istanbul, Turkey, October 10–13, 2010. Available at http://cs.unb.ca/~uluru/Publications/stress_dynamics_paper_070610.pdf; accessed September 25, 2012.
15. Griffith J: Multilevel analysis of cohesion's relation to stress, well-being, identification, disintegration, and perceived combat readiness. *Mil Psychol* 2002; 14(3): 217–39.
16. Bacharach SB, Bamberger PA, Doveh E: Firefighters, critical incidents, and drinking to cope: the adequacy of unit-level performance factors as a source of vulnerability and protection. *J Appl Psychol* 2008; 93(1): 155–69.
17. Atkinson M, Guezt A, Wein L: A dynamic model for posttraumatic stress disorder among U.S. troops in Operation Iraqi Freedom. *Manage Sci* 2009; 55(9): 1454–68.
18. Mostashari A, Sussman JM: Engaging Stakeholders in Engineering Systems Representation and Modeling. Presented at the MIT Engineering Systems Symposium, Cambridge, MA, March 31, 2004. Available at <http://esd.mit.edu/symposium/pdfs/papers/mostashari.pdf>; accessed September 25, 2012.
19. *Invisible Wounds of War: Psychological and Cognitive Injuries, Their Consequences, and Services to Assist Recovery*. Edited by Tanielian T, Jaycox LH. Santa Monica, CA, RAND Corporation, 2008.
20. Belasco A: Troop Levels in the Afghan and Iraq Wars, FY2001–FY2012: Cost and Other Potential Issues. Congressional Research Service Report to Congress, July 2009. Available at <http://www.fas.org/sgrp/crs/natsec/R40682.pdf>; accessed September 25, 2012.
21. Accession Medical Standards Analysis and Research Activity: Annual Report 2010: Attrition and Morbidity Data for FY2009 Accessions. 2010. Available at http://www.amsara.amedd.army.mil/Documents/AMSARA_AR/AMSARA_AR_2010.PDF; accessed September 25, 2012.
22. Jonas WB, O'Connor FG, Deuster P, Peck J, Shake C, Frost SS: Why total force fitness? *Mil Med* 2010; 175(8): 6–12.
23. Park CL, Cohen LH, Murch RL: Assessment and prediction of stress-related growth. *J Pers* 1996; 64(1): 71–104.
24. Fontana A, Rosenheck R: Psychological benefits and liabilities of traumatic exposure in the war zone. *J Trauma Stress* 1998; 11(3): 485–503.
25. Bartone PT: Resilience under military operational stress: can leaders influence hardiness? *Mil Psychol* 2006; 18(Suppl): S131–48.
26. Hoge CW, Castro CA, Messer SC, McGurk D, Cotting DI, Koffman RL: Combat duty in Iraq and Afghanistan, mental health problems, and barriers to care. *New Engl J Med* 2004; 351(1): 13–22.
27. Department of Defense Office of Security Review: Fiscal year (FY) 2012 Budget Estimates: Operation and Maintenance Procurement Research, Development, Test and Evaluation. Defense Health Program, February 2011. Available at http://comptroller.defense.gov/defbudget/fy2012/budget_justification/pdfs/09_Defense_Health_Program/DHP_FY2012_Budget_Estimates_Vol_I.pdf; accessed September 25, 2012.
28. Carey B: Mental Stress Training is Planned for U.S. Soldiers. *New York Times* August 18, 2009. Available at http://www.nytimes.com/2009/08/18/health/18psych.html?_r=0; accessed September 25, 2012.
29. Conrad K: Senate Approves National PTSD Awareness Day. United States Senator Kent Conrad. Available at <http://www.conrad.senate.gov/pressroom/record.cfm?id=336885>; accessed August 24, 2012.
30. McCombs M: The agenda-setting function of the press. In: *The Press: Institutions of American Democracy Series*, Chapter 9, pp 156–68. Edited by Overholser G, Jamieson KH. New York, Oxford University Press and The Annenberg Foundation Trust at Sunnyslans, 2005.
31. Office of the Surgeon Multi-National Force-Iraq, Office of the Command Surgeon, and Office of the Surgeon General United States Army Medical Command: Mental Health Advisory Team (MHAT) V: Operational Iraqi Freedom 06-08, Operation Enduring Freedom. 8 February 2008. Available at http://www.armymedicine.army.mil/reports/mhat/mhat_v/Redacted1-MHATV-4-FEB-2008-Overview.pdf; accessed September 25, 2012.
32. Pols H, Oak S: War & military mental health: the US psychiatric response in the 20th century. *Am J Public Health* 2007; 97: 2132–42.
33. Bowles S, Bates M: Military organizations and programs contributing to resilience building. *Mil Med* 2010; 175(6): 11–21.
34. Grady BJ: A comparative cost analysis of an integrated military telemental health-care service. *Telemed J E-Health* 2002; 8(3): 293–300.
35. Cardona RA, Ritchie EC: U.S. military enlisted accession mental health screening: history and current practice. *Mil Med* 2007; 172: 31–5.
36. Nash WP: U.S. Marine Corps and Navy combat and operational stress continuum model: a tool for leaders. In: *Combat and Operational Behavioral Health*. Edited by Ritchie EC. Washington, DC, Borden Institute Press, 2011.
37. National Center for PTSD: DSM-IV-TR criteria for PTSD. National Center for PTSD. Available at <http://www.ptsd.va.gov/professional/pages/dsm-iv-tr-ptsd.asp>; accessed August 1, 2010.
38. Luthar SS, Sawyer JA, Brown PJ: Conceptual issues in studies of resilience: past, present, and future research. *Ann NY Acad Sci* 2006; 1094: 105–15.
39. Werner EE: Resilience research: Past, present, and future. In: *Resilience in Children, Families, and Communities*. Edited by Peters RDV, Leadbeater B, McMahon RJ. New York, Kluwer, 2005.
40. Linley PA, Joseph S: Positive change following trauma and adversity: a review. *J Trauma Stress* 2004; 17(1): 11–21.
41. Janoff-Bulman R: Schema-change perspectives on posttraumatic growth. In: *Handbook of Posttraumatic Growth: Research and Practice*. Edited by Galhoun LG, Tedeschi RG. Mahwah, NJ, Erlbaum, 2006.
42. Tedeschi G, McNally RJ: Can we facilitate posttraumatic growth in combat veterans? *Am Psychol* 2011; 66 (1): 19–24.
43. Zoellner T, Maercker A: Posttraumatic growth and psychotherapy. In: *Handbook of Posttraumatic Growth: Research and Practice*. Edited by Calhoun LG, Tedeschi RG. New York, Lawrence Erlbaum Associates, 2006.
44. Koenig HG, Pargament KI, Nielsen J: Religious coping and health status in medically ill hospitalized older adults. *J Nerv Ment Dis* 1998; 186(9): 513–21.
45. Harris D, Marr LM: A Population-Based, Risk-Adjusted Model for Forecasting Psychological Health Provider Workforce Needs. Presented at the Academy Health Annual Research Meeting, June 13, 2011. Available at <http://www.cna.org/sites/default/files/HRP%20ARM%202011%20harris.pdf>; accessed September 25, 2012.