

MIT Open Access Articles

Variable Frequency Multiplier Technique for High-Efficiency Conversion Over a Wide Operating Range

The MIT Faculty has made this article openly available. **Please share** how this access benefits you. Your story matters.

Citation: Inam, Wardah, et al. "Variable Frequency Multiplier Technique for High-Efficiency Conversion Over a Wide Operating Range." IEEE Journal of Emerging and Selected Topics in Power Electronics 4, 2 (June 2016): 335–343 © 2016 Institute of Electrical and Electronics Engineers (IEEE)

As Published: <http://dx.doi.org/10.1109/jestpe.2015.2461615>

Publisher: Institute of Electrical and Electronics Engineers (IEEE)

Persistent URL: <http://hdl.handle.net/1721.1/111024>

Version: Author's final manuscript: final author's manuscript post peer review, without publisher's formatting or copy editing

Terms of use: Creative Commons Attribution-Noncommercial-Share Alike



Variable Frequency Multiplier Technique for High Efficiency Conversion Over a Wide Operating Range

Wardah Inam, *Student Member, IEEE*, Khurram K. Afridi, *Member, IEEE*, and David J. Perreault, *Fellow, IEEE*

Abstract—This paper presents a Variable Frequency Multiplier (VFX) technique that enables design of converters for wide input and/or output voltage ranges while preserving high efficiency. The technique is applied to an LLC converter to demonstrate its effectiveness for converters having wide input voltage variation such as universal input power supplies. This technique compresses the effective operating range required of a resonant converter by switching the inverter and/or rectifier operation between processing energy at a fundamental frequency and one or more harmonic frequencies. The implemented converter operates over an input voltage range of 85 V to 340 V but the resonant tank and conversion ratio has only been designed for half this range; a VFX mode of the inverter is used to enhance this to the full range. Experimental results from a 50 W converter show an efficiency of 94.9% to 96.6% across the entire input voltage range, demonstrating the advantage of using this technique in such applications.

Index Terms- dc/dc converter, power supplies resonant converter, high efficiency power converter, variable frequency multiplier

I. INTRODUCTION

A trend in power electronics has been to strive for high power density and high efficiency across a wide operating range [1]. High power density can be achieved by switching power converters at a high frequency. At these high frequencies, resonant converters use soft switching (i.e. Zero Voltage Switching (ZVS) and/or Zero Current Switching (ZCS)) to reduce switching losses to achieve high efficiency [2], [3]. Although soft-switched resonant converters can achieve high efficiency at a nominal operating point, the efficiency tends to degrade considerably with variations in input voltage, output voltage and power level [4].

Resonant converters commonly use frequency control [2], [3] and/or phase shift control [5], [6] to compensate for variations in input voltage and power levels. If switching frequency is increased to reduce output power or gain of the converter, such as in a series resonant converter operated above resonance to maintain ZVS, switching losses increase. Also, with operation over a wide frequency range as often required in resonant converters, the magnetics cannot be optimally designed. Furthermore, circulating currents may increase proportionally as load is decreased resulting in higher losses at light loads. With phase shift control, operation over a wide range is likewise challenging. In many resonant converters, when two legs of the inverter are phase shifted with respect to each other, they have asymmetrical current levels at the switching transitions. The leading inverter leg can lose ZCS and the lagging leg can lose ZVS. Other control techniques such as

asymmetrical current mode control [7] and asymmetrical duty cycle PWM control [8] also have limitations such as loss of ZVS.

In this paper, a Variable Frequency Multiplier (VFX) technique is introduced and its effectiveness is demonstrated for a universal input power supply. In the VFX technique, additional "frequency multiplier" modes of operation of the inverter and/or rectifier are used to provide additional sets of operating characteristics for the converter to achieve and maintain high performance across a wide operating range. Frequency multiplier circuits are often used in extreme high-frequency RF applications (e.g., where transistor f_T is a concern), and are sometimes used in switched-mode inverters and power amplifiers (e.g., [9], [10]). While it has been proposed to employ frequency multipliers in dc-dc converters (e.g., [11]), this is not usually done, as the output power of a frequency multiplier inverter is inherently low relative to the needed device ratings. However, here we propose using frequency multiplication as an additional operating mode of the inverter and/or rectifier, for wide-range voltage and/or power conditions. In this context, frequency multiplication can be used to extend the efficient operating range of a converter and improve its performance across power and voltage. It is noted that the concept of using frequency multiplication with multiple gain settings was employed in the inverter of a high-power dc-dc converter in reference [12]. However, this approach is suited to extremely high-power/high-voltage designs where multilevel inverter structures are feasible and enable flexibility in selecting operating methodologies. In comparison we describe an approach which does not require the high flexibility of multilevel inverters to provide wide-range operation. Moreover, we exploit the proposed concept in the context of a universal-input power supply, in which two separate gain settings can be effectively utilized in different operating environments (different regions of the world) without frequent mode shifting. As will be seen, this application of the concept is valuable because mode shifting imposes rebalancing of dc capacitor voltage levels which can be difficult to apply on a frequent basis.

While the proposed VFX technique can be applied to the inverter and/or rectifier and for wide input and/or output voltage ranges, here we demonstrate it for wide input voltage range using VFX operation of the inverter and describe how this can be applied to the rectifier. Universal input power supplies need to operate over a wide input voltage range and

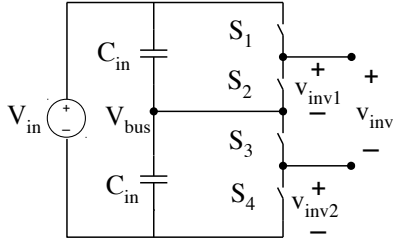

Figure 1: Stacked bridge inverter with input voltage V_{in} and output voltage v_{inv} .

it is a challenge to design resonant power converters for such wide range of operation. In this paper, we demonstrate the VFX technique employed in the inverter of an LLC resonant converter designed to operate across a 4:1 input voltage range of 85 V to 340 V.

This paper is organized as follows. In section II, the Variable Frequency Multiplier technique is introduced and discussed for an inverter and rectifier. Section III presents the design and analysis of a dc/dc LLC converter operating in two VFX modes for a universal input power supply. Experimental results of the prototype are presented in section IV, and section V concludes the paper.

II. VARIABLE FREQUENCY MULTIPLIER

The Variable Frequency Multiplier (VFX) technique can be applied to the inverter stage and/or rectifier stage of a converter to achieve wide input voltage and/or output voltage range operation or to extend the efficient operating power range. In this technique, the duty ratio and the switching frequency of an inverter and/or rectifier is changed as input and/or output voltages change such that it processes power between dc and a specific harmonic of its switching frequency (rather than just its fundamental) to create different modes of operation. By operating between dc and a higher harmonic, the dc-ac (or ac-dc) voltage gain of the inverter or rectifier changes, and one gains an added operating mode with different transfer characteristics. In case of frequency control this allows the converter to be operated over a narrower (intermediate ac) frequency range for a wide voltage conversion range and/or power range. Depending on the circuit architecture, more than two modes can be created.

This paper describes the use of the VFX technique applied to the inverter stage and/or rectifier stage of resonant or other ac-link converters. To demonstrate the utility of this technique, we have built an LLC converter with a two-mode VFX technique applied to the inverter stage to efficiently extend the input voltage range of the converter.

A. Technique Applied to an Inverter

To understand the VFX technique applied to an inverter consider the stacked bridge inverter as shown in Fig. 1 with an output voltage v_{inv} ($v_{inv} = v_{inv1} + V_{bus} - v_{inv2}$).

This inverter under VFX control operates in two modes: Fundamental VFX mode (mode 1) and second harmonic VFX

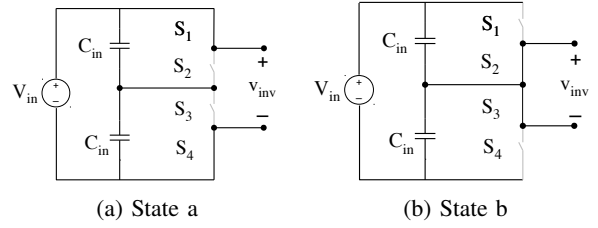

Figure 2: Stacked bridge inverter with input voltage V_{in} and output voltage v_{inv} in mode 1.

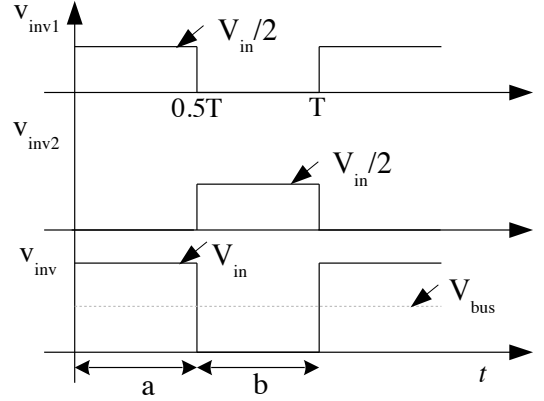

Figure 3: Output voltages of the two inverters v_{inv1} and v_{inv2} and the resultant inverter voltage v_{inv} in Mode 1.

mode (mode 2). This change in mode is synthesized by changing the switching pattern of the inverter switches and it results in an output voltage (v_{inv}) which is of different magnitude hence it changes the voltage gain of the inverter. In mode 1, there are two switching states in one switching period as summarized in Table I. In state a switches 1 and 4 are on and in state b switches 2 and 3 are on as shown in Fig. 2. Mode 1 results in twice the amplitude of the individual inverter outputs as shown in Fig. 3.

In mode 2, there are four switching states in one switching period as summarized in Table II. The VFX mode results in half the gain and double the frequency of the output waveform for a single switching cycle as shown in Fig. 5. Thus for the transformation stage to see the same frequency as in mode 1, in this mode the converter is operated at half the switching frequency of mode 1 (with each switching device operating at half the rate of the output ac waveform).

To create these switching patterns and to extend this to other topologies, frequency analysis is useful. Considering Fourier analysis, the square pulse output of inverter 1 (Fig. 6) can be

Table I: Switch states and the output voltage of the inverter in fundamental VFX mode (Mode 1).

State	On switches	v_{inv}
a	1, 4	V_{in}
b	2, 3	0

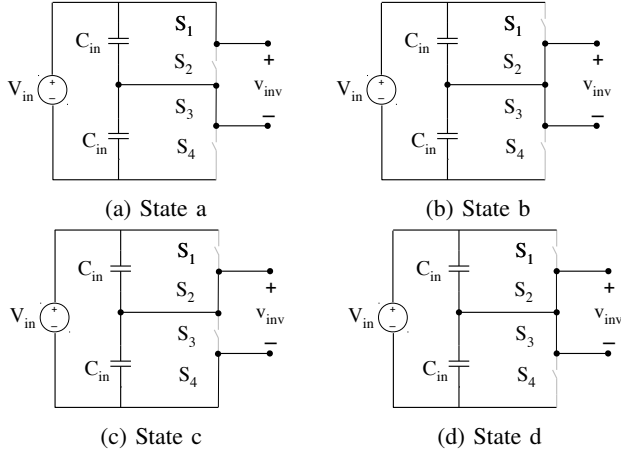

Figure 4: Stacked bridge inverter with input voltage V_{in} and output voltage v_{inv} in mode 2.

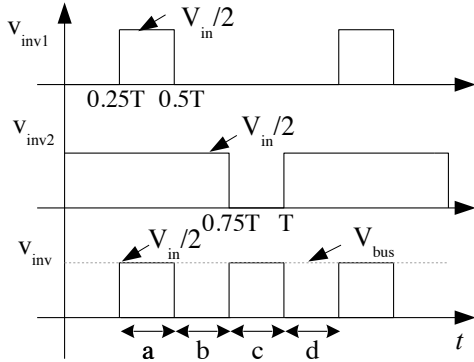

Figure 5: Output voltages of the two inverters v_{inv1} and v_{inv2} and the resultant inverter voltage v_{inv} in Mode 2.

expressed as the following Fourier series:

$$v_{inv1} = \frac{D_1 V_{in}}{2} + \sum_{n=1}^{\infty} \frac{V_{in}}{\pi n} \sin(n\pi D_1) \cos\left(\frac{2\pi n t}{T}\right). \quad (1)$$

Here V_{in} is the input voltage, T is the switching period and D_1 is the duty ratio of inverter 1. The output of inverter 2 (v_{inv2}) is described by a similar equation but with duty ratio D_2 .

Figure 7 shows the amplitude of the fundamental of this waveform and several harmonic voltages as a function of the selected duty ratio. The amplitude has been normalized to

Table II: Switch states and output voltage of the inverter in the second harmonic VFX mode (mode 2).

State	On switches	V_{inv}
a	1, 3	$V_{in}/2$
b	2, 3	0
c	2, 4	$V_{in}/2$
d	2, 3	0

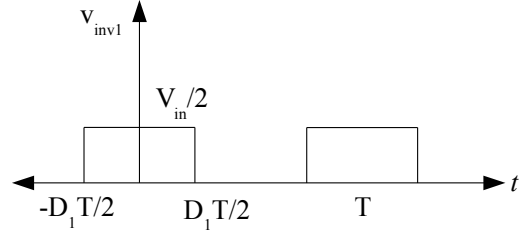

Figure 6: Square pulse train output (v_{inv1}) with duty cycle D_1 and time period T .

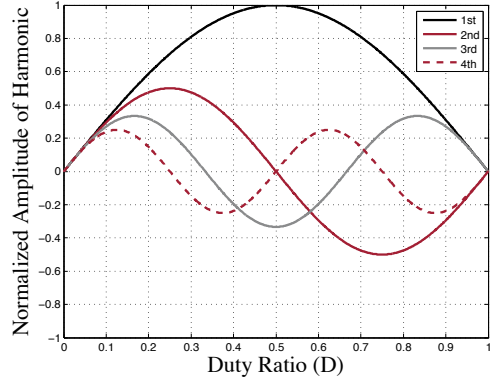

Figure 7: Normalized amplitude of fundamental and harmonics of a rectangular wave with duty ratio D .

the maximum amplitude ($\frac{V_{in}}{\pi}$). By choosing the duty ratio of the half bridges correctly, we can synthesize a desired output waveform, while canceling (or reducing) undesired frequencies. In mode 1, the fundamental of the half-bridge inverter waveforms have to be reinforced. Hence, the duty ratios $D_1 = 0.5$ and $D_2 = 0.5$ are chosen. As the output is the difference between the inverter output voltages (v_{inv1} and v_{inv2}) hence to reinforce these waveforms the two half bridges have to be switched 180° out of phase, as shown in Fig. 3 and expressed in Equation (2).

$$v_{inv1} = \frac{V_{in}}{2} + \sum_{n=1}^{\infty} \frac{2V_{in}}{\pi n} \sin(n\pi 0.5) \cos\left(\frac{2\pi n t}{T}\right). \quad (2)$$

In mode 2, the second harmonic has to be reinforced hence $D_1 = 0.25$ and $D_2 = 0.75$ are chosen which correspond to the maximum amplitude of the second harmonic. As the output voltage of the inverter is the difference between the two half bridge inverter voltages (v_{inv1} and v_{inv2}) hence to reinforce the second harmonic the two waveforms have to be in phase. In this mode the fundamental of the half bridge waveforms is canceled while the second harmonic is reinforced so the output frequency doubles while the output amplitude is halved, as shown in Fig. 5 and expressed in Equation (3), where $k = 2n$.

$$v_{inv1} = \frac{V_{in}}{4} + \sum_{k=1}^{\infty} \frac{2V_{in}}{\pi k} \sin(k\pi 0.5) \cos\left(\frac{2\pi k t}{T}\right). \quad (3)$$

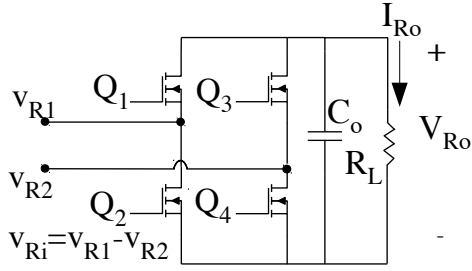

Figure 8: Full bridge synchronous rectifier with a resistive output load.

For the same output frequency the two inverters switch at half the frequency. Note that in each case (for the two-mode VFX inverter) the ac output waveform is a square wave. This technique can thus be used in any number of ac link topologies, including all kinds of resonant converters and dual-active bridge converters.

B. Technique Applied to a Synchronous Rectifier

A rectifier receives an ac current (or voltage) at its input and presents an ac voltage (or current) at its output, which results in dc power being absorbed and delivered to the output as dc voltage and current. The amount of power absorbed depends on the amplitude of the voltage (or current) presented at the input of the rectifier. Hence, the VFX technique can likewise be applied to the rectifier to make the ac voltage at its input be either at the fundamental of the rectifier devices switching frequency or at a harmonic of the devices switching frequency in order to convert the ac input power to dc.

For example, consider a full bridge synchronous rectifier as shown in Fig. 8. Similar to the inverter presented in the previous section, we can create two modes of operation by changing the switching pattern of Q_1, Q_2, Q_3 and Q_4 , which determines the rectifier input voltage. In mode 1, the input voltage of leg 1 of the rectifier (v_{R1}) is equal to the rectifier output voltage (V_{Ro}) for half the switching cycle (Q_1 and Q_4 switched on), while the input voltage of leg 2 of the rectifier (v_{R2}) is zero. In the second half of the switching cycle (Q_2 and Q_3 switched on) v_{R2} is equal to V_{Ro} and v_{R1} is zero, as shown in Fig. 9. The resulting voltage at the input of the rectifier v_{Ri} is the difference of the input voltages of the two rectifier legs ($v_{Ri} = v_{R1} - v_{R2}$) and is either $+V_{Ro}$ or $-V_{Ro}$ with 50% duty ratio. The voltage waveform at the input of the rectifier (shown in Fig. 9), can be used to determine the gain of the rectifier in mode 1.

$$M_{R,mode1} = \frac{V_{Ro}}{v_{Ri,pk-pk}} = \frac{V_{Ro}}{2V_{Ro}} = 0.5. \quad (4)$$

In mode 2, v_{R1} is equal to V_{Ro} for 75% duty cycle and v_{R2} is phase shifted by 90 degrees and equal to V_{Ro} for 25% duty

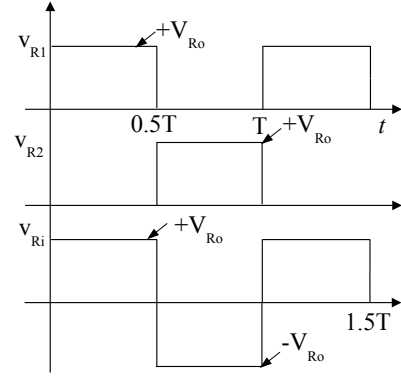

Figure 9: Voltage waveforms at the rectifier input during mode 1.

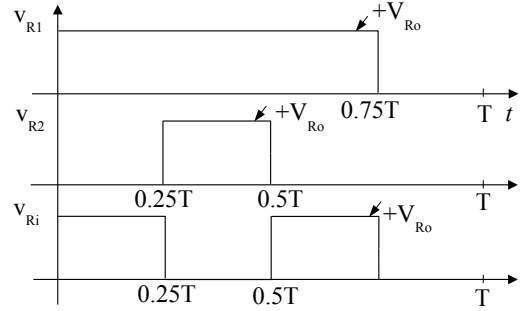

Figure 10: Voltage waveforms at the rectifier input during mode 2.

cycle. The resulting rectifier input voltage v_{Ri} has twice the frequency of the rectifier switches and is either V_{Ro} or 0. In order to have the same input (ac) voltage frequency as mode 1, the rectifier switches are switched at half the frequency of mode 1 (with all devices operating at the same frequency). The resulting voltage waveforms are shown in Fig. 10 and as seen from the figure the gain of the rectifier doubles in mode 2.

$$M_{R,mode2} = \frac{V_{Ro}}{v_{Ri,pk-pk}} = \frac{V_{Ro}}{V_{Ro}} = 1. \quad (5)$$

This gives us the opportunity to operate the converter with double the output voltage (if the input voltage remains the same) effectively increasing the output voltage range of the converter.

With the rectifier driven by a nearly sinusoidal current waveform (due to a resonant tank in a resonant converter), we can control the amount of power transferred by controlling the phase difference between the current and the input voltage of the rectifier. Consider a simplified case when the input voltage and current are in phase: using Fundamental Harmonic Approximation (FHA) we can represent the effective input of the rectifier as an equivalent resistor ($R_{eqv} = k_0 R_L$) where

R_L is the output load resistor, and k_o is a constant which depends on the ratio between the fundamental harmonic of the voltage and the current.

In mode 1, the fundamental frequency components of the voltage waveform and the current waveform for the rectifier of Fig. 9 are given by:

$$v_{Ri-ac,mode1} = \frac{4}{\pi} V_{Ro} \sin(\omega t). \quad (6)$$

$$i_{Ri-ac,mode1} = \frac{\pi}{2} I_{Ro} \sin(\omega t). \quad (7)$$

Where V_{Ro} is the dc rectifier output voltage, I_{Ro} is the dc rectifier output current. The ratio of the ac voltage and current, representing the equivalent resistance, is given as:

$$R_{eqv,mode1} = \frac{v_{Ri-ac,mode1}}{i_{Ri-ac,mode1}} = \frac{8}{\pi^2} R_L. \quad (8)$$

Where R_L is the dc load resistor at the output of the rectifier, equal to V_{Ro}/I_{Ro} (for continuous steady-state operation). Using two-mode VFX technique, we alter the rectifier characteristics (while still operating with a “resistive” characteristic) by changing the switching pattern of the switches. The magnitude of the fundamental frequency component of the ac rectifier input voltage v_{Ri-ac} decreases by half:

$$v_{Ri-ac,mode2} = \frac{2}{\pi} V_{Ro} \sin(\omega t). \quad (9)$$

For the same output power, I_{Ro} increases by half, so the input current is given by:

$$i_{Ri-ac,mode2} = \pi I_{Ro} \sin(\omega t). \quad (10)$$

Hence, the equivalent resistance is equal to:

$$R_{eqv,mode1} = \frac{2}{\pi^2} R_L. \quad (11)$$

The second operating mode in VFX gives us the opportunity to adjust the voltage and current profile of the rectifier (e.g., keeping an equivalent ac input resistance at a different dc output voltage, or changing the effective ac output resistance for a given dc resistive loading on the rectifier).

The two-mode VFX technique presented can be easily extended to higher modes, given an appropriate rectifier structure. It can likewise be applied to many other rectifier topologies, such as stacked rectifiers, voltage-fed rectifiers, current-doubler rectifier, etc.

III. DESIGN OF AN LLC CONVERTER OPERATING WITH VFX TECHNIQUE

We demonstrate the proposed technique in a dc-dc converter designed for a two-stage universal laptop power supply. The ac voltage varies in different countries but the nominal voltage is either 110-120 Vrms at 60 Hz, or 220-240 Vrms at 50 Hz. Therefore, 120 Vrms and 240 Vrms have been selected as the upper limits for the two modes of converter operation, corresponding to peak dc voltages of 170 V and 340 V applied to the dc-dc converter. The variable frequency multiplier

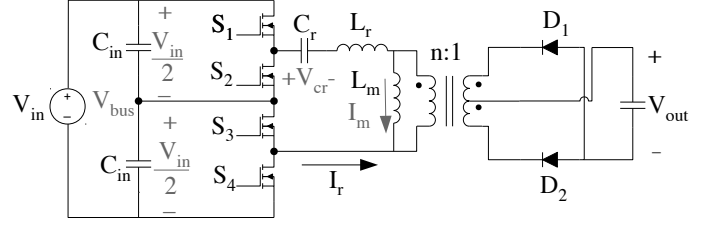

Figure 11: Schematic of the LLC converter with a stacked bridge inverter incorporating the VFX technique.

technique is very useful for this application because there are two distinct peak input voltages.

An LLC converter has been selected for the dc/dc stage. It uses frequency control to regulate the output voltage and has many advantages. The main advantages are that it has the capability to regulate the output voltage over a wide range of input voltage and power with only a small variation in the switching frequency [13]. Also, it achieves zero voltage switching (ZVS) over the entire range of operation thus reducing the switching losses. Moreover, the leakage and magnetizing inductance of the transformer can be incorporated into the design.

Figure 11 shows the schematic of the LLC converter with an inverter appropriate for voltage step-down and VFX operation. As it has a high input voltage, stacked half bridges are used. This reduces the voltage stress of the transistors by half, which increases their performance with available devices. The transformation stage consists of a series inductor (L_r) and a capacitor (C_r) and a parallel inductor (L_m). The capacitor not only provides resonant filtering but also provides dc blocking for flux balancing.

The transformer parasitics, leakage and magnetizing inductance, can be used instead of separate inductors [14]. A center-tapped transformer is used to reduce the number of series diodes in the rectification path. This increases the loss of the transformer and the voltage stress of the diodes. However, this trade off is still beneficial because of the low output voltage. Synchronous rectification can be used to further reduce losses in the rectification stage [15], [16], [17]. The converter is designed using the method outlined in [18]. Fundamental Harmonic Approximation (FHA) is used to analyze and design the converter. Time-based [19] and approximate methods [20], [21] can be used for more accurate gain analysis.

The converter is designed for a maximum input voltage of 170 V in the fundamental mode and an output voltage of 20 V. To ensure that the power supply (of which the dc/dc converter is the second stage) has a sufficiently high power factor (i.e., greater than 0.95), the minimum input voltage for the dc-dc stage is 85 V. For input voltages above 170 V, the second harmonic VFX mode is used to decrease the voltage that the transformation stage sees by half.

Using Fundamental Harmonic Approximation, all the voltages and currents are represented by their fundamental components and the secondary-side variables are reflected to the primary side to obtain the approximated circuit shown in Fig.

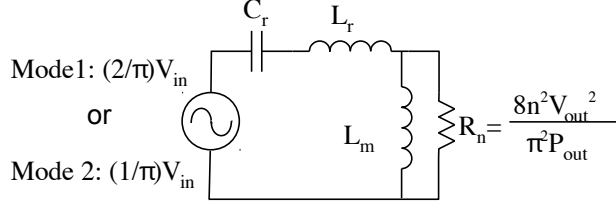

Figure 12: Fundamental harmonic model of the LLC converter.

12.

In mode 1, the dc output voltage of the inverter is $V_{in}/2$ as shown in Fig. 3. Hence, transformer turns ratio has been selected as:

$$n = \frac{V_{in-max}}{2V_{out}} = 4.25. \quad (12)$$

The recommended range for the ratio of L_m/L_r (referred to as k) is between 3 to 10 [18]. Smaller values of k result in a narrow and steep gain curve but a much higher magnetizing current, resulting in higher loss. To have a reasonable minimum frequency, magnetizing current and dead time, the value of k is chosen as 7. The value of k can be optimized for a narrower frequency range or a higher efficiency depending on the intended application. The maximum gain (M_{max}) of the resonant network is selected higher than 2 (i.e., 2.4) to ensure sufficient gain even with the inaccuracies of using FHA.

To ensure ZVS, the input impedance of the resonant network needs to be inductive at the drive frequency. The borderline between the inductive and capacitive region is when the impedance is purely resistive. By equating the imaginary part of input impedance ($x - \frac{1}{x} + \frac{xk}{1+k^2x^2Q^2}$) equal to zero the value of Q is found.

$$Q = \sqrt{\frac{1}{(1-x^2)k} - \frac{1}{k^2x^2}} \quad (13)$$

Here $x = f_{inv}/f_r$, where f_{inv} is the inverter output frequency (which is the switching frequency in mode 1 and twice the switching frequency in mode 2) and f_r is the resonant tank frequency ($f_r = \frac{1}{2\pi\sqrt{L_r C_r}}$). Substituting the value of Q in the expression for gain M we can get the maximum gain (M_{max}).

$$M = \sqrt{\frac{1}{(1 + \frac{1}{k}(1 - \frac{1}{x^2})^2 + Q^2(x - \frac{1}{x})^2)}, \quad (14)$$

$$M_{max} = \frac{x}{\sqrt{x^2(1 + \frac{1}{k}) - \frac{1}{k}}}$$

At the maximum gain we get the minimum normalized frequency. This value of x_{min} is substituted in the expression of Q to get the maximum Q below which ZVS is maintained.

$$Q_{max} = \frac{1}{k} \sqrt{\frac{1 + k(1 - \frac{1}{M_{max}^2})}{M_{max}^2 - 1}} = 0.1706. \quad (15)$$

Table III: Components used in the experimental prototype.

Components	Type
Controller	150 MHz digital signal controller (TI's TMS320F28335).
Signal Isolators	150 Mbps two channel digital isolator (NVE Corporation's IL711), Qty: 2.
Gate Drivers	600-V/4-A High and low side gate driver (IR's IRS21867), Qty: 2.
Transistors	200-V/34-A OptiMos power transistor (Infineon's IPD320N20N3), Qty: 4.
Capacitors	Cr: 15.99 pF/250 V, Cout: 20 μ F/25-V, Cin: 1 μ F/250-V Qty: 2.
Inductors	Lr: 3.6 μ H, RM8A100 3F3 core, litz wire (6 turns, 48 AWG, 1000 strands).
Transformer	RM10A160 3F3 core, Primary litz wire (17 turns, 46 AWG, 450 strands). Secondary litz wire (4 turns, 46 AWG, 450 strands).
Diodes	60-V/3-A Schottky diode (NXP's PMEG6030), Qty: 2.

The values of n, k, R_n and Q_{max} are used to calculate L_r, L_m and C_r :

$$L_r = \frac{Q_{max} R_n}{\omega_r} = 6.36 \mu H,$$

$$L_m = k L_r = 44.5 \mu H, \quad (16)$$

$$C_r = \frac{1}{Q_{max} R_n \omega_r} = 15.9 \mu F.$$

The dead time should be sufficient such that the current in the inductor L_m at the switching instant can discharge the voltage on the MOSFET before it is switched on. By equating the charge required to discharge the capacitors to the current in inductor L_m during the dead-time, the dead-time is calculated as $t_d = 8C_{ds} f_r L_m = 62 ns$. Using Fundamental Harmonic Approximation, the gain curve of the transformation stage is given in Fig. 13a.

If the converter had been designed without considering the VFX technique as a half bridge implementation, the operating voltage range would have been 85 V to 340 V. This results in transformer being designed for double the transformer turns ratio, 8.5 rather than 4.25, as calculated from Equation. 12. Also, the maximum gain (M_{max}) of the transformation stage would have to be double, 4 rather than 2, resulting in higher inductor loss. As the rest of the components would remain the same the overall loss would increase.

IV. EXPERIMENTAL PROTOTYPE AND RESULTS

Using the design values from the previous section, a prototype for the converter was built as seen in Fig. 14. The components used for the experimental prototype are summarized in Table III.

The dc/dc converter is a step-down converter operating at the series tank (L_r, C_r) resonant switching frequency (f_r) of 500 kHz. It has an input voltage range of 85 V - 340 V, fixed output voltage of 20 V and a rated output power of 50 W. Table IV summaries the converter specifications. To control the output power and gain, frequency control is utilized, while the

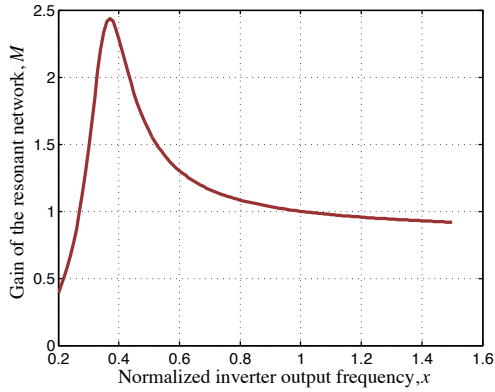

(a) The gain (M) of the transformation stage using FHA. It has a peak gain at inverter output voltage frequency (f_{inv}) of 0.4 times the resonant tank (L_r and C_r) frequency.

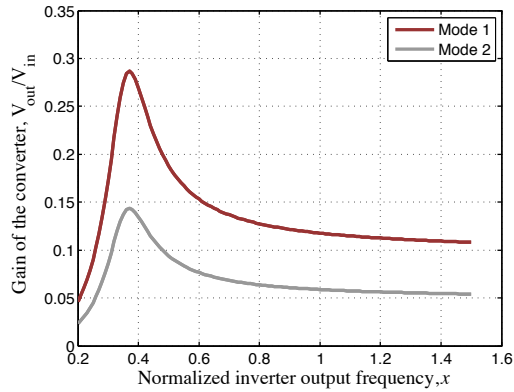

(b) The gain of the converter (V_{out}/V_{in}) using FHA. In mode 1 the voltage gain is twice the voltage gain of Mode 2.

Figure 13: Gain of (a) the transformation stage and (b) converter, using FHA.

Table IV: Prototype converter specifications

Parameter	Value
Input voltage (V_{in})	85 - 340 V
Output voltage (V_{out})	20 V
Output power (P_{out})	5 - 50 W

appropriate VFX mode is used based on input voltage being above or below 170 V. The transformer was designed to exploit the integrated magnetizing inductance. The leakage inductance was used as part of the resonant inductance. However, this was insufficient and a series inductor was added to provide the required series resonant inductance.

The prototype was tested using a resistive load. The converter operates with ZVS across the entire range of operation. The switching waveforms for input voltages of 170 V and 85 V at 50 W output power, in mode 1, are given in Fig. 15 (a) and (b), respectively. It shows the current input to the

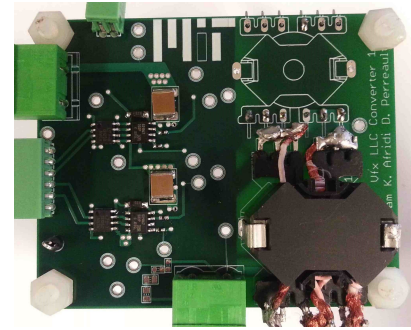

(a) Top side

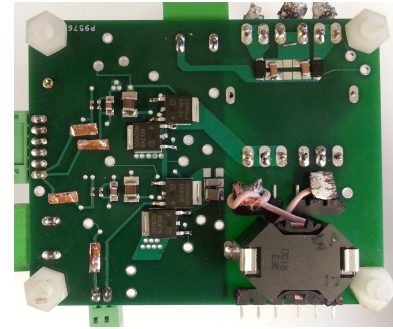

(b) Bottom side

Figure 14: Picture of the (a) top side and (b) bottom side of the prototype board.

transformer primary which is also the output current of the bottom inverter, the gate drive voltage of switch S_4 and the drain-source voltage of switch S_4 . At 170 V (Fig. 15 (a)) the current is sinusoidal with a cusp at the switching instants. In this mode, the voltage across the two input capacitors was not completely balanced, however, the voltage difference was very less (around 10 V). Hence additional voltage balancing techniques were not utilized. The converter was operated below resonance, to increase the gain of the transformation stage, as the input voltage decreased. As the converter is operated away from resonance the current waveform distorts and does not remain sinusoidal, as seen from Fig. 15 (b). However, the experimental gain is very similar to that calculated by fundamental harmonic approximation and ZVS is still maintained.

For input voltages above 170 V, operation is changed to the VFX mode and the waveforms for 340 V and 170 V are given in Fig. 15 (c) and (d), respectively. The converter is operated at half the normal-mode switching frequency, which decreases the frequency-dependent switching losses and ZVS is still maintained resulting in high efficiency.

The efficiency of the converter was measured across input voltage in both modes and across output power. The measured efficiency of the converter at rated power as a function of input voltage is plotted in Fig. 16 (a). The converter continues to operate with high efficiency with the mode change and the converter efficiency varies from 94.9% to 96.6% across the entire range of input voltages. The measured efficiency as a

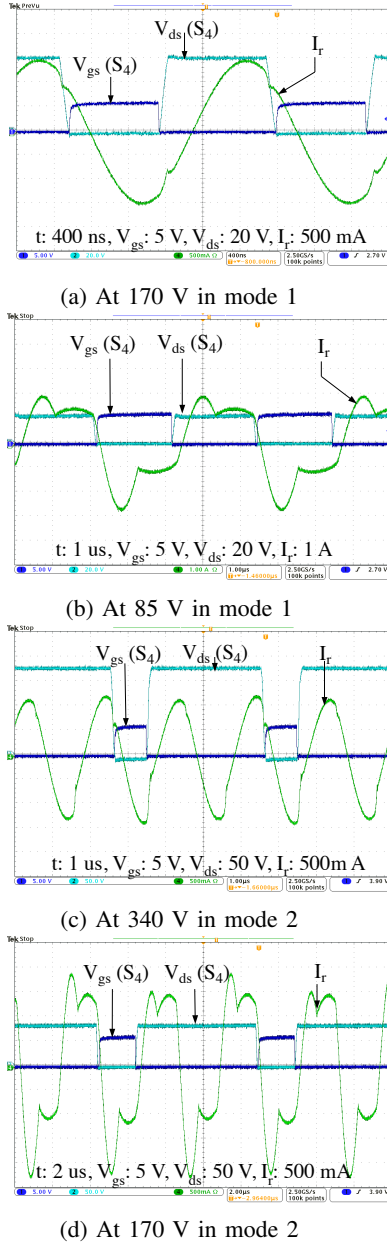
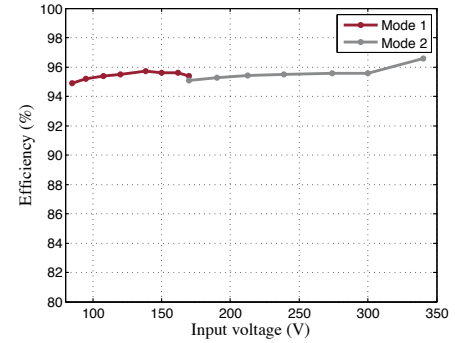

Figure 15: Current and voltage waveforms of the converter at 50 W when operated in mode 1, fundamental mode, and in mode 2, VFX mode. (1-Blue) Gate voltage of switch S_4 , (2-Turquoise) drain-source voltage of switch S_4 , and (4-Green) current output of lower half-bridge that is flowing in to the transformer primary.

function of output power and fixed input voltage of 170 V in fundamental mode varies from 86% to 95.4% and is plotted in Fig. 16 (b). The high efficiency over a wide operation range demonstrates the effectiveness of the VFX technique.

V. CONCLUSION

Variable Frequency Multiplier (VFX) technique is applied to the inverter of an LLC converter, to demonstrate the effectiveness of this technique for universal input power supplies. This



(a) Efficiency vs Input voltage

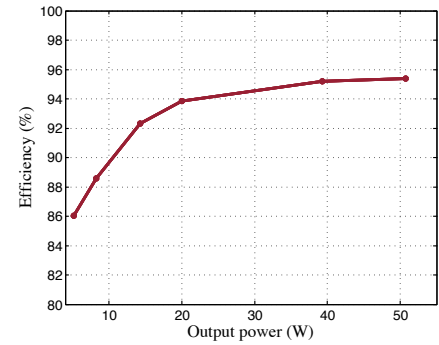

(b) Efficiency vs output power

Figure 16: Efficiency of the converter (a) with variation in input voltage with fixed output voltage and 50 W output power operating in mode 1 and 2 and (b) with variation in output power with 170 V input voltage and fixed output voltage operating in mode 1.

technique increases the input voltage range by a factor of two and the converter achieves high efficiency over a wide range of operation. The experimental prototype is able to achieve an efficiency of 94.9% to 96.6% across the entire input voltage range at 50 W output power and 86% to 95.4% across a 10:1 power range with 170 V input voltage. Hence, the VFX technique can be very useful to obtain high efficiency across a wide range of operation.

ACKNOWLEDGMENT

The authors gratefully acknowledge the support provided for this work by the MIT-SkTech Strategic Development Project and by the National Science Foundation under NSF award number 1307699.

REFERENCES

- [1] D. Huang, D. Gilham, W. Feng, P. Kong, D. Fu, and F. Lee, "High power density high efficiency dc/dc converter," in *Energy Conversion Congress and Exposition (ECCE), 2011 IEEE*, Sept 2011, pp. 1392–1399.
- [2] R. Steigerwald, "High-frequency resonant transistor dc-dc converters," *Industrial Electronics, IEEE Transactions on*, vol. IE-31, no. 2, pp. 181–191, May 1984.
- [3] —, "A comparison of half-bridge resonant converter topologies," *Power Electronics, IEEE Transactions on*, vol. 3, no. 2, pp. 174–182, Apr 1988.

- [4] S. Bai, Z. Pantic, and S. Lukic, "A comparison study of control strategies for zvs resonant converters," in *IECON 2010 - 36th Annual Conference on IEEE Industrial Electronics Society*, Nov 2010, pp. 256–262.
- [5] J.-P. Vandellac and P. D. Ziogas, "A dc to dc pwm series resonant converter operated at resonant frequency," *Industrial Electronics, IEEE Transactions on*, vol. 35, no. 3, pp. 451–460, 1988.
- [6] P. Jain, A. St-Martin, and G. Edwards, "Asymmetrical pulse-width-modulated resonant dc/dc converter topologies," *Power Electronics, IEEE Transactions on*, vol. 11, no. 3, pp. 413–422, May 1996.
- [7] F.-S. Tsai, P. Materu, and F. Lee, "Constant-frequency clamped-mode resonant converters," *Power Electronics, IEEE Transactions on*, vol. 3, no. 4, pp. 460–473, Oct 1988.
- [8] P. Jain, A. St-Martin, and G. Edwards, "Asymmetrical pulse-width-modulated resonant dc/dc converter topologies," *Power Electronics, IEEE Transactions on*, vol. 11, no. 3, pp. 413–422, May 1996.
- [9] R. Zulinski and J. W. Steadman, "Idealized operation of class e frequency multipliers," *Circuits and Systems, IEEE Transactions on*, vol. 33, no. 12, pp. 1209–1218, Dec 1986.
- [10] K. Shinoda, T. Suetsugu, M. Matsuo, and S. Mori, "Idealized operation of class de amplifier and frequency multipliers," *Circuits and Systems I: Fundamental Theory and Applications, IEEE Transactions on*, vol. 45, no. 1, pp. 34–40, Jan 1998.
- [11] K. Shinoda, M. Fujii, H. Koizumi, T. Suetsugu, and S. Mori, "Phase-controlled resonant dc/dc converter with class e frequency multiplier," in *Telecommunications Energy Conference, 1995. INTELEC '95., 17th International*, Oct 1995, pp. 107–113.
- [12] R. Li, M.-F. Vancu, F. Canales, and D. Aggeler, "High performance dc-dc converter for wide voltage range operation," in *Power Electronics and Motion Control Conference (IPEMC), 2012 7th International*, vol. 2, June 2012, pp. 1151–1158.
- [13] B. Yang, F. Lee, A. Zhang, and G. Huang, "Llc resonant converter for front end dc/dc conversion," in *Applied Power Electronics Conference and Exposition, 2002. APEC 2002. Seventeenth Annual IEEE*, vol. 2, 2002, pp. 1108–1112 vol.2.
- [14] B. Yang, R. Chen, and F. Lee, "Integrated magnetic for llc resonant converter," in *Applied Power Electronics Conference and Exposition, 2002. APEC 2002. Seventeenth Annual IEEE*, vol. 1, 2002, pp. 346–351 vol.1.
- [15] D. Fu, Y. Liu, F. Lee, and M. Xu, "A novel driving scheme for synchronous rectifiers in llc resonant converters," *Power Electronics, IEEE Transactions on*, vol. 24, no. 5, pp. 1321–1329, May 2009.
- [16] D. Fu, B. Lu, and F. Lee, "1mhz high efficiency llc resonant converters with synchronous rectifier," in *Power Electronics Specialists Conference, 2007. PESC 2007. IEEE*, June 2007, pp. 2404–2410.
- [17] D. Fu, Y. Liu, F. Lee, and M. Xu, "An improved novel driving scheme of synchronous rectifiers for llc resonant converters," in *Applied Power Electronics Conference and Exposition, 2008. APEC 2008. Twenty-Third Annual IEEE*, Feb 2008, pp. 510–516.
- [18] H. Ding, "Design of resonant half-bridge converter using irs2795 (1, 2) control ic," *International Rectifier Application note, AN*, pp. 11–60.
- [19] J. Lazar and R. Martinelli, "Steady-state analysis of the llc series resonant converter," in *Applied Power Electronics Conference and Exposition, 2001. APEC 2001. Sixteenth Annual IEEE*, vol. 2, 2001, pp. 728–735 vol.2.
- [20] G. Ivensky, S. Bronshtein, and A. Abramovitz, "Approximate analysis of resonant llc dc-dc converter," *Power Electronics, IEEE Transactions on*, vol. 26, no. 11, pp. 3274–3284, Nov 2011.
- [21] X. Fang, H. Hu, Z. Shen, and I. Batarseh, "Operation mode analysis and peak gain approximation of the llc resonant converter," *Power Electronics, IEEE Transactions on*, vol. 27, no. 4, pp. 1985–1995, April 2012.