

A FINITE DIFFERENCE
TECHNIQUE FOR THE ANALYSIS
OF THIN, ELASTIC PLATES

27200/1
302
by
27201
3020

STUART DAVID WERNER
SB, University of Illinois
(1961)

MS, Northwestern University
(1962)

Submitted in partial fulfillment
of the requirements for the degree of
Civil Engineer

at the
Massachusetts Institute of Technology
(1965)

Signature of Author
Department of Civil Engineering (August 22, 1965)

Certified by

Accepted by
Chairman, Departmental Committee on Graduate Students

ABSTRACTA FINITE DIFFERENCE TECHNIQUE
FOR THE ANALYSIS OF THIN ELASTIC PLATES

by

STUART DAVID WERNER

Submitted to the Department of Civil Engineering on August 22, 1965 in partial fulfillment of the requirements for the degree of Civil Engineer.

In the past, the analysis of plates using finite differences has utilized artificial points lying off the surface of the plate when assembling molecules for gridpoints in the vicinity of the boundary. This method of accounting for the boundary conditions introduces serious errors in the resulting molecules.

The primary purpose of the finite difference plate analysis presented herein is to provide an accurate, systematic method of accounting for boundary conditions when assembling molecules for gridpoints in the vicinity of the boundary. This is done by expressing v^a_w at the gridpoint as a linear combination of the boundary conditions for the side, the displacements at neighboring gridpoints, and, if necessary, the values of v^a_w at neighboring gridpoints. Each of these quantities is expanded in a Taylor series about the central gridpoint, and the coefficients of like derivatives on each side of the above expression for v^a_w at the central gridpoint are equated. This will result in a system of equations which can be solved for the molecule at the central gridpoint.

In addition to the above method of accounting for boundary conditions, this analysis also presents a method for computing the bending and twisting moments at the interior gridpoints, the principal moments at the interior gridpoints, and the bending moments, transverse shear force, and/or vertical displacement, (depending on the particular boundary condition), at up to 1000 points along the boundary.

Thesis Supervisor:

Jerome Connor

Title:

Associate Professor of Civil Engineering

ACKNOWLEDGMENT

The author wishes to express his appreciation to Professor Jerome Connor for his guidance and encouragement throughout the course of this thesis work. The author would also like to thank fellow graduate students John Wolf and Roger Miller for their assistance with the organization and computer programming of this plate analysis.

TABLE OF CONTENTS

	PAGE
I. Title page	1
II. Abstract	11
III. Acknowledgment	111
IV. Table of Contents	1v
V. Body of Text	
A. Introduction	1
B. Assumptions and Limitations	6
C. Procedure	
Chapter I - Input	8
Chapter II - Boundary Conditions	23
Chapter III - Automatic Assemblage of Difference Equations at the Gridpoints	34
Chapter IV - Determination of Moments, Reactions, and/or Displacements Along the Boundaries	47
Chapter V - Solution, Back Substitution, and Output for Plate Analysis	57
D. Computing Programming of the Plate Analysis	64
E. Conclusions	68
VI. Figures	69
VII. Bibliography and References	95
VIII. Appendices	
A. Definition of Symbols	96
B. List of Figures	99
C. List of Tables	102

IX. Source Programs for Plate Analysis

V

BODY OF TEXT

A. INTRODUCTION

One of the primary problems faced when analyzing thin elastic plates using standard finite differences methods is that of properly accounting for the boundary conditions in assembling the molecule for gridpoints near the boundary. In the standard method, artificial gridpoints lying outside of the plate are created. As will be shown, this could conceivably result in an inaccurate molecule for the interior gridpoints in the vicinity of the boundary.

To illustrate this, let us consider a gridpoint such as point 0 in figure (1) which is located near the boundary of a simply supported plate. The numbers in parenthesis in figure (1) are the molecule for point 0 obtained using the standard finite difference approach.

In order to evaluate the accuracy of the standard finite difference molecule $\nabla^4 w$ at point 0 can be expressed as a linear combination of the surrounding points lying within the plate. (The deflection at point 11 is dependent on that of the interior gridpoints and therefore does not have to be considered). This is expressed mathematically as follows:

$$(1) \quad A_0 w_0 + \sum_{\substack{i=1 \\ i \neq 11}}^{12} A_i w_i = \nabla^4 w_0$$

where the A's are arbitrary constants. Each of the above displacements can now be expanded in a Taylor Series about point. In this example, these expansions will be up to the sixth derivative of the displacement at 0, and are as follows:

$$\omega_1 = \omega_0 + h\omega_{0,x} + \frac{h^2}{2}\omega_{0,xx} + \frac{h^3}{6}\omega_{0,xxx} + \frac{h^4}{24}\omega_{0,xxxx} + \frac{h^5}{120}\omega_{0,xxxxx}$$

$$\omega_2 = \omega_0 + h\omega_{0,y} + \frac{h^2}{2}\omega_{0,yy} + \frac{h^3}{6}\omega_{0,yyy} + \frac{h^4}{24}\omega_{0,yyyy} + \frac{h^5}{120}\omega_{0,yyyyy}$$

⋮

$$\omega_3 = \omega_0 + h\omega_{0,x} + h\omega_{0,y} + \frac{h^2}{2}\omega_{0,xx} + h^2\omega_{0,xy} + \frac{h^2}{2}\omega_{0,yy} + \frac{h^3}{6}\omega_{0,xxx} + \frac{h^3}{2}\omega_{0,xyx} + \frac{h^3}{2}\omega_{0,xyy} + \frac{h^3}{6}\omega_{0,yyy} + \dots + \frac{h^5}{120}\omega_{0,yyyyy}$$

⋮

(2)

$$\omega_{12} = \omega_0 - 2h\omega_{0,y} + 2h^2\omega_{0,yy} - \frac{4}{3}h^3\omega_{0,yyy} + \frac{2h^4}{3}\omega_{0,yyyy} - \frac{32h^5}{120}\omega_{0,yyyyy}$$

After substitution of (2), (1) is written in the following form:

$$\begin{aligned} & \omega_0 [A_1 + A_2 + \dots + A_5 + \dots + A_{12}] + h\omega_{0,x} [A_1 + \dots + A_5 + \dots] \\ & + h\omega_{0,y} [A_2 + \dots + A_5 + \dots - 2A_{12}] + \dots \\ & \vdots \\ & + \frac{h^5}{120}\omega_{0,yyyyy} [A_2 + \dots + A_5 + \dots - 32A_{12}] = \nabla^4 \omega_0 \end{aligned}$$

or, in matrix form:

		ω_0	ω_1	ω_2	ω_3	ω_4	ω_5	ω_6	ω_7	ω_8	ω_9	ω_{10}	ω_{12}	$\nabla^2 \omega$
ω_0	1	1	1	1	1	1	1	1	1	1	1	1	1	0
$\omega_{0,x}$	0	1	0	-1	0	1	-1	-1	1	1	2	0	0	0
$\omega_{0,y}$	0	0	1	0	-1	1	1	-1	-1	0	0	2	-2	0
$\omega_{0,xx}$	0	1	0	1	0	1	1	1	1	4	0	0	0	0
$\omega_{0,yy}$	0	0	0	0	0	2	-2	2	-2	0	0	0	0	0
$\omega_{0,xy}$	0	0	1	0	1	1	1	1	1	0	4	4	4	0
$\omega_{0,xxx}$	0	0	0	-1	0	1	-1	-1	1	8	0	0	0	0
$\omega_{0,xyy}$	0	0	0	0	0	3	3	-3	-3	0	0	0	0	0
$\omega_{0,yyx}$	0	0	0	0	0	3	-3	-3	3	0	0	0	0	0
$\omega_{0,yyy}$	0	0	-1	0	-1	1	1	-1	-1	0	8	-8	0	0
$\omega_{0,xxxx}$	0	1	0	1	0	1	1	1	1	16	0	0	0	-1
$\omega_{0,xyxx}$	0	0	0	0	0	4	-4	4	-4	0	0	0	0	0
$\omega_{0,xyyy}$	0	0	0	0	0	6	6	6	6	0	0	0	0	2
$\omega_{0,xyyx}$	0	0	0	0	0	4	-4	4	-4	0	0	0	0	0
$\omega_{0,xyyy}$	0	0	-1	0	1	1	1	1	1	0	16	16	1	0
$\omega_{0,xxxxx}$	0	1	0	-1	0	1	-1	-1	1	32	0	0	0	0
$\omega_{0,xxxxy}$	0	0	0	0	0	5	5	-5	-5	0	0	0	0	0
$\omega_{0,xxxxy}$	0	0	0	0	0	10	-10	-10	10	0	0	0	0	0
$\omega_{0,xxxxy}$	0	0	0	0	0	10	10	-10	-10	0	0	0	0	0
$\omega_{0,xyyyy}$	0	0	0	0	0	5	-5	-5	5	0	0	0	0	0
$\omega_{0,xyyyy}$	0	0	1	0	-1	1	1	-1	-1	0	32	-32	0	0

Now, if the standard finite difference molecule were accurate up to the sixth derivative of the series expansions, the solution of equation (3) would yield:

$$(4) \quad \begin{array}{ll} A_0 = 19 & A_6 = 2 \\ A_1 = -8 & A_7 = 2 \\ A_2 = -8 & A_8 = 2 \\ A_3 = -6 & A_9 = 1 \\ A_4 = -8 & A_{10} = 1 \\ A_5 = 2 & A_{12} = 1 \end{array}$$

which corresponds to the molecule given in Fig. (1).

The constants given in (4) can be shown to identically satisfy the first 10 equations in (3). However, upon substitution into the equation for $\omega_{0,xxxx}$, we have:

$$(5) \quad \begin{aligned} & 1x(A_1=-8) + 1x(A_3=-6) + 1x(A_5=2) + 1x(A_6=2) + 1x(A_7=2) \\ & + 1x(A_8=2) + 16x(A_9=1) = 10 \neq 1x \frac{4!}{h^4} \end{aligned}$$

Therefore, the standard finite difference molecule leads to a contradiction in the fourth derivative of the series expansion for the displacement at point 0. Since the quantity being solved for is also a fourth derivative term, $(\nabla^4 \omega_0)$, it is seen that the standard finite difference method gives molecules

for gridpoints in the vicinity of the boundary that are inherently inaccurate.

In view of the above falacies, the need for a modification of the standard finites difference method is readily apparent. Therefore, in what follows, a new type of finite difference technique for the analysis of plates is proposed. This new technique considers only points within the plate domain and, as will be shown, is well within the accuracy required for a satisfactory solution of the plate problem.

B. ASSUMPTIONS AND LIMITATIONS

1. Shape of Plate

This analysis will be valid for plates with up to 100 straight sides, but is not valid for curved plates.

2. Interior Conditions

Any holes that exist in the interior of the plate are made up of straight sides. Also, the theory is valid for any transverse loading distribution.

3. Boundary Conditions

The following boundary conditions can be handled by this analysis:

- a) Fixed edges
- b) Simply supported edges
- c) Free edges
- d) Edges elastically restrained against rotation
- e) Edges elastically restrained against vertical displacement
- f) Edges elastically restrained against both rotation and displacement
- g) Edge of plate connected to free edgebeam
- h) Edge of plate connected to simply supported edgebeam

In boundary conditions (g) and (h), the centroid of the edge beams is assumed to coincide with the center of flexure

4. Assumptions in Small Deflection Plate Theory

- a) Effect of deflections on bending of plate is negligible
- b) σ_z , (normal stress in transverse direction), is negligible.
- c) The plate thickness is negligible compared to any representative length or width of the plate.
- d) The thickness of the plate is constant.
- e) An infinite transverse shear rigidity is assumed.
- f) St. Venant beam theory is assumed valid.

5. Orientation of Plate (see figure (2))

- a) The plate will be in the x-y plane and all displacements, w, will be in the z direction.
- b) The positive direction along the tangent to each edge of the plate will be such that the interior of the plate will be on the left (+s direction)
- c) The positive direction of the normal to each edge of the plate will be pointing away from the interior of the plate. (+n direction)

6. Direction of Stress Resultants and Bending Moments

The positive directions of all stress resultants and bending moments is given by figure (3).

CHAPTER I

INPUT

An example problem will be used to explain the input. It is seen that, although the exterior boundary and interior contours can each have an unlimited number of sides, each side must be straight, and not curved. This particular example has one exterior, and two interior boundaries, and is shown in figure (4).

1. Title Cards

The first card to be read in as input will contain the name of the deck, "Plate Analysis", and will be in the form shown in figure (5a).

The next card will be a title card and will contain the name of the particular problem being considered. This name is completely arbitrary; for example, the name of this example problem was chosen to be "Example Thesis Problem, Superplate". The form by which the problem name is to be punched on the data card is shown in figure (5b).

2. Plate Data And Connectivity Data

The user will next read in the following constants for the plate:

- a) DP = flexural rigidity of plate (lb. in²/in)
- b) POIS = poissons ratio
- c) NS = total number of sides (= cornerpoints) (up to 100 sides)
- d) NC = total number of contours (no limit to this number)

This will all be on one card, as shown in figure (6).

The user then numbers all cornerpoints and sides arbitrarily and, for each side, reads in the side number, initial and terminal points, and boundary conditions of the side. There will be one such card for each side in the plate, and the form of these cards is shown in figure (7).

Internally, this set of side data cards will be stored as a connectivity matrix MCONS (I,J) ; I = 1, -- 4, J = 1 --- NS, in which the first row contains the side numbers, the second row contains the initial cornerpoints for each side, the third row contains the terminal cornerpoints, and the fourth row contains the boundary conditions for each side. Note that only the first three rows are actually concerned with the connectivity of the various contours.

The method of boundary condition input and internal storage are indicated in detail in Table (1), (2), and (3).

Table 1

Boundary Condition Input

<u>BOUNDARY CONDITION</u>	<u>READ IN</u>
1) Fixed ended	<u>FIXED</u>
2) Simply supported	<u>SIMPLE SUPPORT</u>
3) Free edges	<u>FREE</u>
4) Elastically restrained against displacement and rotation	<u>ELASTIC</u>
5) Edge of plate connected to free edgebeam	<u>FREE EDGEBEAM</u>
6) Edge of plate connected to simply supported edgebeam	<u>SIMPLY SUPPORTED EDGEBEAM</u>

Table 2

Internal Storage of Boundary Conditions

<u>BOUNDARY CONDITION INPUT</u>	<u>STORED IN COMPUTER AS:</u>
FIXED	1
SIMPLE SUPPORT	2
FREE	3
ELASTIC	4
FREE EDGEBEAM	5
SIMPLY SUPPORTED EDGEBEAM	6

Table 3

Formation of Connectivity Matrix for Superplate

READER INPUT:

Side 10	From 4 to 10	FREE
Side 3	From 8 to 4	SIMPLE SUPPORT
Side 8	From 10 to 9	FIXED
Side 6	From 5 to 11	ELASTIC
Side 4	From 1 to 3	FREE
Side 1	From 2 to 1	FIXED
Side 2	From 2 to 6	ELASTIC
Side 5	From 13 to 11	SIMPLE SUPPORT
Side 9	From 9 to 8	FREE EDGEBEAM
Side 14	From 3 to 6	FIXED
Side 7	From 5 to 13	SIMPLY SUPPORTED EDGEBEAM

INTERNAL STORAGE IN COMPUTER:

CONNECTIVITY MATRIX

Side No.	10	3	8	6	4	1	2	5	9	14	7
FROM CORNER PT	4	8	10	5	1	2	2	13	9	3	5
TO CORNER PT	10	4	9	11	3	1	6	11	8	6	13
B. C.	3	2	1	4	3	1	4	2	5	1	6

3. Initial Rearrangement of Connectivity Matrix

The computer will now determine successive cornerpoints and sides using MCONS(4,NS) for each contour, check the numbers of contours with NC, and will check that all sides and cornerpoint numbers have been used.

In the rearranged connectivity matrix, neighboring columns (of the same contour) correspond to consecutive sides. The second and third rows are rearranged so that the direction of travel about each contour is consistent; the second row contains all negative adjoint corners, and the third row contains all positive adjoint corners. The actual direction of travel for an interior or exterior contour (ie, whether clockwise or counterclockwise) is arbitrary. This initial rearrangement of the connectivity matrix for this example problem is shown in Table(8a).

After rearranging MCONS(4,NS), the computer will form the vector NSC(NC) (= number of sides per contour). For this example:

$$NSC(1) = 4$$

$$NSC(2) = 3$$

$$NSC(3) = 4$$

4. Corner Point Input and Final Rearrangement of Connectivity Matrix

The user will now input the cornerpoint numbers MC(I), I =1,----NS, along with their absolute coordinates in inches, CPC(K,I), K=1,2, I=1,---NS. The order in which these cornerpoints and their coordinates is read in is completely arbitrary.

A typical cornerpoint data card is shown in figure (8).¹⁴

The manner in which this matrix of cornerpoints and their coordinates is stored internally is as indicated in Table (4).¹⁴

The connectivity matrix will now be rearranged once again, in order to coincide with a consistent direction of travel along exterior contours and interior contours. These assumed directions of travel and the corresponding rearrangement of the connectivity matrix will now be examined in detail.

Table 4

Internal Storage of Corner Point Data for Superplate

MC(I)	1	2	6	3	4	8	9	10	5	11	13
CPC(1,I)	4.8	18.	8.7	59.	46.8	31.2	30.	48.	60.	60.5	47.
CPC(2,I)	24.	4.	18.	74.5	34.8	39.	24.	24.2	55.7	44.4	51.6

a) The positive direction of a boundary is such that the interior lies on the left as one traverses the boundary. This corresponds to the counterclockwise direction for an exterior contour and clockwise for an interior boundary. Using this as a guide, the computer will rearrange the columns of the connectivity matrix such that:

(1) The exterior boundary occupies the first few columns of MCONS(4,NS).

(2) The second and third rows will be rearranged, if necessary, so that the direction of travel about each contour will be positive. This will correspond to a counterclockwise arrangement of cornerpoints for the exterior boundary, and a clockwise arrangement of cornerpoints for the interior boundaries.

The criteria used in examining the direction consists of determining the sign of the area inside a contour, as described below.

b) Positive Direction of Travel about Contours.

(1) Determine area under each contour (A_n)

$$A_n = \frac{Y_P + Y_N}{2} (X_P - X_N)$$

where

P = cornerpoint positive adjoint (row 3 in MCONS)

N = cornerpoint negative adjoint (row 2 in MCONS)

(2) Determine total area of contour: $A_T(I)$, $I=1, \dots, NC$

$$AC = \sum_n^{NS} A_n$$

(3) We now examine the sign of the area:

If AC(-), direction of travel is counterclockwise

If AC(+), direction of travel is clockwise

(4) We now examine the relative magnitudes of the areas

of the contours. The contour with the largest

absolute magnitude will correspond to the external

boundary. This contour will be moved to the left

so that it occupies the first few columns of MCONS(4,NS).

Example:

$$AC(1) = +20$$

$$AC(2) = +15$$

$$AC(3) = +100$$

Since AC(3) is largest, it is the exterior boundary. The direction of travel about this external boundary is clockwise since AC(3) is positive. However, since the positive direction of travel about an exterior contour is counterclockwise, rows 2 and 3 of contour 3 will have to be interchanged.

AC(2) and AC(1) are also clockwise since the sign of their area is positive. However, since they are interior points, the clockwise sense is positive. Therefore, rows 2 and 3 of contours 1 and 2 do not have to be interchanged.

See table (8b) for the rearranged matrix MCONS(4,NS) for the plate of figure (1).

Table 4a

Initial Rearrangement of Connectivity Matrix

Side No.	10	8	9	3	6	5	7	4	14	2	1
From Corner Pt.	4	10	9	8	5	11	13	1	3	6	2
To Corner Pt.	10	9	8	4	11	13	5	3	6	2	1
B.C.	3	1	5	2	4	2	6	3	1	4	1
	First contour				Second contour			Third contour			

Table 5b

Final Rearrangement of Connectivity Matrix

Side No.	4	1	2	14	10	8	9	3	6	5	7
From Corner Pt.	3	1	2	6	4	10	9	8	5	11	13
To Corner Pt.	1	2	6	3	10	9	8	4	11	13	5
B.C.	3	1	4	1	3	1	5	2	4	2	6
	external contour				internal contour			internal contour			

- (c) After rearranging the rows and columns as shown in Table (8b), the computer will now compute the direction cosine and sine for each side in each contour.

For Side I:

$$\cos \alpha_i = \text{COSS}(I) = \frac{XP - XN}{[(XP - XN)^2 + (YP - YN)^2]^{1/2}}$$

$$\sin \alpha_i = \text{SINS}(I) = \frac{YP - YN}{[(XP - XN)^2 + (YP - YN)^2]^{1/2}}$$

where XN, YN are the second and third rows in CPC(2,NS) for the cornerpoint corresponding to the second row in the rearranged matrix, MCONS (4,NS), of Table (8b). XP, YP, are the second and third rows in CPC(2,NS)

for the cornerpoint corresponding to the third row of the rearranged connectivity matrix.

5. Additional Information Data for Boundary Conditions

If an edge of the plate is either elastically restrained, connected to a free edgebeam, or connected to a simply supported edgebeam, additional structural constants must be read in. This is done as follows:

a) On the first card in this sequence, the total number of sides that are either elastically restrained, connected to a free edgebeam, or connected to a simply supported edgebeam are read in. This total number of sides for additional information is needed, (NSAI), is read in as shown in figure (10a).

b) Two cards must now be read in for each side. The first card will have the side number on it, and the second card will have whatever additional information is needed for that side.

c) The additional information for each type boundary condition is read into the computer in the following manner:

- 1) If the sides is fixed, simply supported, or free, no additional information is needed.
- 2) For an elastically restrained edge, the quantities SCR and SCD must be read in on the second card, where:

SCR = rotational spring constant - $\frac{(lb-in)}{in}$

SCD = translational spring constant - (lb/in^2)

3) If the side is connected to a free edgebeam,
EI, GJ, and HOR must be read in on the second card,
where:

EI = flexural rigidity of edgebeam about n axis $(lb-in^2)$

GJ = torsional rigidity of edgebeam $(lb-in^2)$

HOR = horizontal distance from shear center of edgebeam
to junction of plate and beam (inches).

4) For a side connected to a simply supported edgebeam,
the quantities GJ and HOR, defined as for a free
edgebeam, are read in.

See figures (10b)-(10d) for the format of these data
cards.

6. Interior Grid Information

The interior grid information will now be read in. This
input will be generated in the following manner:

- a) On the first card, the grid size in inches, H, the
total number of internal points, NP, and the total number
of loading conditions, NL, are punched. This program has
a capacity of 1000 gridpoints and 3 loading conditions.
- b) There will be one subsequent card for each internal
gridpoint. The first item on a given card will be the
absolute number of the given gridpoint, where the absolute
number is a four digit co-ordinate expressed as a multiple
of the grid size, H. The first two digits in the absolute

number correspond to the y coordinate, and the second two digits correspond to the x coordinate of the gridpoint. (Example: An absolute number of 0203 means that the gridpoint has a y coordinate of $2xH$ and an x coordinate of $3xH$.)

c) The next 3 items on the gridpoint card will be vertical load at the point per unit area (lb/in^2) corresponding to each loading condition.

See figure (11) for typical interior grid information cards.

7. Rearrangement of Gridpoint List

The computer now rearranges the gridpoints so that they are now listed parallel to the smallest side of the rectangle enclosing the plate. This will tend to minimize the width of the band matrix in the final system of equations.

Now, let us define MDIM as the maximum number of points spaced a distance H apart that can be placed along the shortest side of the enclosing rectangle ab . Since this shortest side corresponds to the maximum possible width of the actual plate, it follows that MDIM is the maximum number of gridpoints that can be spaced along the width of the actual plate. Since MDIM will be important when solving the final system of equations, it is now computed and stored.

8. Computation of Boundary Points

The computer now determines the points along the boundary

(their coordinates) at which the reactions will later be calculated.

a) Determination of number of cornerpoints for a given side.

- 1) The computer first determines the distance between the 2 cornerpoints of the side, by using their coordinates which have been previously read in.
- 2) This distance is then divided by the gridpoint spacing H , and the result is truncated.
- 3) The number of equally spaced boundary points = truncated result - 1.
- 4) This process is repeated for each side.

Example: length of side = 9.0 ft; grid spacing = 7.0 in.

a) Divide by H : $9.0 \times \frac{12}{7.0} = 15.4$

b) Truncated result = 15

c) Number of equally spaced boundary points on the side = $15 - 1 = 14$

b) Each interior boundary point (except cornerpoints) is assigned the number zero. As an example, we consider the plate of figure (12).

c) The computer first lists the boundary points as follows:

LBPE = (3,0,0,0,5,5,0,0,0,0,0,0,14,14,0,0,----etc.)

where

LBPE = list of boundary points expanded

Note that each corner point is listed twice- once for each side that frames into it (see Fig. 13)

d) The computer then lists the side number corresponding to each successive point number

LBPSE = (11,11,11,11,11,12,12,12,12,12,12,12,12,19,19,19,etc.)

where

LBPSE = list of boundary points with respect to a side expanded

e) The computer then lists the x and y coordinates of each boundary point:

XBPE = (--,--,--,--,--, etc.) = x coordinates

YBPE = (--,--,--,--,--, etc.) = y coordinates

The successive numbers in XBPE and YBPE are the x,y coordinates respectively of each successive boundary point given in LBPE

9. Problem Specified Card

The final input card in the data reads "PROBLEM SPECIFIED", as shown in figure (13). This tells the computer that the complete set of data has been read in and that the computations can now begin.

CHAPTER II

BOUNDARY CONDITIONS

The various boundary conditions discussed in Chapter I will now be formulated.

1) Fixed ended case

The boundary conditions for a fixed edge are:

$$(2-1) \quad w = \frac{dw}{dn} = 0$$

where, from Fig. (14a), we obtain:

$$\frac{dw}{dn} = \frac{dw}{dx} \frac{dx}{dn} + \frac{dw}{dy} \frac{dy}{dn} = w_{,x} \sin \alpha - w_{,y} \cos \alpha$$

In Cartesian coordinates, the boundary conditions corresponding to a fixed edge are:

$$(2-2) \quad w = 0$$

$$(2-3) \quad w_{,x} \sin \alpha_i - w_{,y} \cos \alpha_i = 0$$

2) Simply supported case

The boundary conditions corresponding to a simply supported edge are:

$$(2-4) \quad w = 0$$

$$(2-5) \quad M_n = \frac{d^2 w}{dn^2} + \nu \frac{d^2 w}{ds^2} = 0$$

where

$\frac{\partial^2 w}{\partial s^2}$ is identically zero at the boundary.

Now

$$\frac{\partial^2 w}{\partial n^2} = \frac{\partial}{\partial x} \left(\frac{\partial w}{\partial n} \right) \frac{\partial x}{\partial n} + \frac{\partial}{\partial y} \left(\frac{\partial w}{\partial n} \right) \frac{\partial y}{\partial n} = \frac{\partial}{\partial x} \left(\frac{\partial w}{\partial n} \right) \sin \alpha_i - \frac{\partial}{\partial y} \left(\frac{\partial w}{\partial n} \right) \cos \alpha_i$$

Performing differentiation

$$\frac{\partial^2 w}{\partial n^2} = w_{,xx} \sin^2 \alpha_i - 2w_{,xy} \sin \alpha_i \cos \alpha_i + w_{,yy} \cos^2 \alpha_i$$

Utilizing figure (14b) to evaluate $\frac{\partial w}{\partial s}$,

we get:

$$\frac{\partial w}{\partial s} = \frac{\partial w}{\partial x} \frac{\partial x}{\partial s} + \frac{\partial w}{\partial y} \frac{\partial y}{\partial s} = w_{,x} \cos \alpha_i + w_{,y} \sin \alpha_i$$

$$\frac{\partial^2 w}{\partial s^2} = \frac{\partial}{\partial x} \left(\frac{\partial w}{\partial s} \right) \frac{\partial x}{\partial s} + \frac{\partial}{\partial y} \left(\frac{\partial w}{\partial s} \right) \frac{\partial y}{\partial s}$$

or, upon substituting for $\frac{\partial w}{\partial s}$:

$$\frac{\partial^2 w}{\partial s^2} = w_{,xx} \cos^2 \alpha_i + 2w_{,xy} \sin \alpha_i \cos \alpha_i + w_{,yy} \sin^2 \alpha_i$$

Now, since $\frac{\partial^2 w}{\partial s^2} = 0$:

$$-2w_{,xy} \sin \alpha_i \cos \alpha_i = w_{,xx} \cos^2 \alpha_i + w_{,yy} \sin^2 \alpha_i$$

Substituting into the expression for $\frac{\partial^2 w}{\partial n^2}$:

$$\frac{\partial^2 w}{\partial n^2} = w_{,xx} + w_{,yy}$$

Therefore, the boundary conditions in Cartesian coordinates are:

$$(2-6) \quad \omega = 0$$

$$(2-7) \quad \omega_{,xx} + \omega_{,yy} = 0$$

3) Free Edges

The boundary conditions for a free edge are:

$$(2-8) \quad M_n = DP \left[\frac{\partial^2 \omega}{\partial n^2} + \nu \frac{\partial^2 \omega}{\partial s^2} \right] = 0$$

$$(2-9) \quad Q_{ne} = DP \left[\frac{\partial^3 \omega}{\partial n^3} + (2-\nu) \frac{\partial^3 \omega}{\partial n \partial s^2} \right] = 0$$

It has been shown that:

$$\frac{\partial^2 \omega}{\partial n^2} = \omega_{,xx} \sin^2 \alpha_i - 2\omega_{,xy} \sin \alpha_i \cos \alpha_i + \omega_{,yy} \cos^2 \alpha_i$$

$$\frac{\partial^2 \omega}{\partial s^2} = \omega_{,xx} \cos^2 \alpha_i + 2\omega_{,xy} \sin \alpha_i \cos \alpha_i + \omega_{,yy} \sin^2 \alpha_i$$

Therefore, the boundary condition in Cartesian coordinates corresponding to $M_n=0$ takes the form:

$$(2-10) \quad \omega_{,xx} [\sin^2 \alpha_i + \nu \cos^2 \alpha_i] + \omega_{,yy} [\cos^2 \alpha_i + \nu \sin^2 \alpha_i] \\ - 2\omega_{,xy} \sin \alpha_i \cos \alpha_i (1-\nu) = 0$$

In the boundary condition for Q_{ne} , we evaluate $\frac{\partial^3 \omega}{\partial n^3}$

as:

$$\frac{\partial^3 \omega}{\partial n^3} = \frac{\partial}{\partial x} \left(\frac{\partial^2 \omega}{\partial n^2} \right) \frac{\partial x}{\partial n} + \frac{\partial}{\partial y} \left(\frac{\partial^2 \omega}{\partial n^2} \right) \frac{\partial y}{\partial n}$$

where

$$\frac{\partial x}{\partial n} = \sin \alpha_i ; \quad \frac{\partial y}{\partial n} = -\cos \alpha_i$$

Substituting for $\frac{\partial^2 \omega}{\partial n^2}$:

$$\frac{\partial^3 \omega}{\partial n^3} = \omega_{,xxx} \sin^3 \alpha_i - 3\omega_{,xyx} \sin^2 \alpha_i \cos \alpha_i + 3\omega_{,xyy} \sin \alpha_i \cos^2 \alpha_i - \omega_{,yyy} \cos^3 \alpha_i$$

Now, evaluating $\frac{\partial^3 \omega}{\partial n \partial s^2}$:

$$\frac{\partial}{\partial n} \left(\frac{\partial^3 \omega}{\partial s^2} \right) = \frac{\partial}{\partial x} \left(\frac{\partial^3 \omega}{\partial s^2} \right) \frac{\partial x}{\partial n} + \frac{\partial}{\partial y} \left(\frac{\partial^3 \omega}{\partial s^2} \right) \frac{\partial y}{\partial n}$$

Substituting for $\frac{\partial^3 \omega}{\partial s^2}$, $\frac{\partial x}{\partial n}$, and $\frac{\partial y}{\partial n}$:

$$\begin{aligned} \frac{\partial^3 \omega}{\partial n \partial s^2} = & \omega_{,xxx} \sin \alpha_i \cos^2 \alpha_i + \omega_{,xyx} [2 \sin^2 \alpha_i \cos \alpha_i - \cos^3 \alpha_i] \\ & + \omega_{,xyy} [\sin^3 \alpha_i - 2 \sin \alpha_i \cos^2 \alpha_i] - \omega_{,yyy} \sin^2 \alpha_i \cos \alpha_i \end{aligned}$$

The effective shear now becomes:

$$\begin{aligned} Q_{ne} = DP [& \omega_{,xxx} \sin \alpha_i (\sin^2 \alpha_i + (2-\nu) \cos^2 \alpha_i) \\ & + \omega_{,xyx} \cos \alpha_i (-3 \sin^2 \alpha_i + (2-\nu)(2 \sin^2 \alpha_i - \cos^2 \alpha_i)) \\ & + \omega_{,xyy} \sin \alpha_i (3 \cos^2 \alpha_i + (2-\nu)(\sin^2 \alpha_i - 2 \cos^2 \alpha_i)) \\ & + \omega_{,yyy} \cos \alpha_i (-\cos^2 \alpha_i - (2-\nu) \sin^2 \alpha_i)] \end{aligned}$$

where:

$$\begin{aligned} \sin^2 \alpha_i + 2\cos^2 \alpha_i &= 1 + \cos^2 \alpha_i \\ -3\sin^2 \alpha_i + 4\sin^2 \alpha_i - 2\cos^2 \alpha_i &= 1 - 3\cos^2 \alpha_i \\ 3\cos^2 \alpha_i + 2\sin^2 \alpha_i - 4\cos^2 \alpha_i &= 3\sin^2 \alpha_i - 1 \\ -\cos^2 \alpha_i - 2\sin^2 \alpha_i &= -1 - \sin^2 \alpha_i \end{aligned}$$

Therefore, the boundary condition in Cartesian Coordinates corresponding to $Q_{ne} = 0$ becomes:

$$\begin{aligned} (2-11) \quad & w_{,xxx} \sin \alpha_i (1 + \cos^2 \alpha_i (1 - \nu)) + w_{,xyx} \cos \alpha_i (1 - 3\cos^2 \alpha_i - \nu(3\sin^2 \alpha_i - 1)) \\ & + w_{,xyy} \sin \alpha_i (3\sin^2 \alpha_i - 1 - \nu(1 - 3\cos^2 \alpha_i)) + w_{,yyy} \cos \alpha_i (-1 - \sin^2 \alpha_i (1 - \nu)) \\ & = 0 \end{aligned}$$

4) Elastic Support

The boundary conditions corresponding to an elastically restrained edge are:

$$(2-12) \quad M_n = (SCR) \frac{\partial w}{\partial n}$$

$$(2-13) \quad Q_{ne} = -(SCD)w$$

Substituting for M_n $\frac{\partial w}{\partial n}$ and dividing through by DP , the

first boundary condition becomes:

$$\begin{aligned}
 & \omega_{,xx}[\sin^2 \alpha_i + \nu \cos^2 \alpha_i] + \omega_{,yy}[\cos^2 \alpha_i + \nu \sin^2 \alpha_i] \\
 (2-14) \quad & -2\omega_{,xy} \sin \alpha_i \cos \alpha_i (1-\nu) + \frac{SCD}{DP} (\omega_{,x} \sin \alpha_i - \omega_{,y} \cos \alpha_i) \\
 & = 0
 \end{aligned}$$

Substituting for Q_{ne} and dividing through by DP , the second boundary condition becomes:

$$\begin{aligned}
 (2-15) \quad & \omega_{,xxx} \sin \alpha_i (1 + \cos^2 \alpha_i (1-\nu)) + \omega_{,xxy} \cos \alpha_i (1 - 3\cos^2 \alpha_i - \nu(3\sin^2 \alpha_i - 1)) \\
 & + \omega_{,xyy} \sin \alpha_i (3\sin^2 \alpha_i - 1 - \nu(1 - 3\cos^2 \alpha_i)) + \omega_{,yyy} \cos \alpha_i (-1 - \sin^2 \alpha_i (1-\nu)) \\
 & + \left(\frac{SCD}{DP}\right) \omega = 0
 \end{aligned}$$

5) Edge of Plate Connected to Free Edgebeam

The boundary conditions corresponding to this case are:

- 1) Twist of Beam = $M_n + Q_{ne}(\text{HOR})$
- 2) Distributed Load on Beam = Q_{ne}

We will work with the positive face of the beam when formulating these B.C.'s. Now, it was previously stated that S is positive when the interior of the plate is on the left, and n is positive when pointing outward from the plate interior. Therefore, the positive face of the edge beam is as shown in Figure (16a).

a) Equilibrium Equations (See figure 16b))

$$\underline{\sum F_z = 0}: \quad \frac{\partial F_z}{\partial s} + b_z = 0$$

or

$$(2-16) \quad \frac{\partial F_z}{\partial s} - Q_{ne} = 0$$

$$\underline{\sum M_A = 0}: \quad$$

$$(2-17) \quad \frac{\partial M_{nb}}{\partial s} - F_z = 0$$

$$\underline{\sum T = 0}: \quad$$

$$\frac{\partial M_{sb}}{\partial s} + t = 0$$

where $t = M_{np} + Q_{ne}(\text{HOR})$

$$(2-18) \quad \frac{\partial M_{sb}}{\partial s} + M_{np} + Q_{ne}(\text{HOR}) = 0$$

Differentiate (2-17) and substitute (2-16):

$$(2-19) \quad \frac{\partial^2 M_{nb}}{\partial s^2} - Q_{ne} = 0$$

b) Force displacement Relations:

$$(2-20) \quad M_{nb} = -EI_n \frac{\partial^2 \omega}{\partial s^2}$$

where, for compatibility to be satisfied, $\omega(\text{beam}) = \omega(\text{plate})$ at their line of intersection

From eq'ns (2) and (5):

$$(2-21) \quad F_z = -EI_n \frac{\partial^3 w}{\partial s^3}$$

Torsional moment:

$$(2-22) \quad M_{sb} = GJ \frac{\partial \eta}{\partial s} \quad \text{where } \eta = \text{angle of twist of beam}$$

and

for compatibility to be satisfied

$$\eta(\text{beam}) = \frac{\partial w}{\partial n} (\text{plate}) \text{ at boundary}$$

$$(2-23) \quad M_{sb} = GJ \frac{\partial^2 w}{\partial n \partial s}$$

where

GJ = torsional rigidity of beam

c) Formulation of Boundary Conditions

Differentiate (2-20) twice and substitute (2-19):

$$(2-24) \quad EI_n \frac{\partial^4 w}{\partial s^4} + Q_{ne} = 0$$

where

$$\begin{aligned} \frac{\partial}{\partial s} \left(\frac{\partial^2 w}{\partial s^2} \right) &= \frac{\partial}{\partial x} \left(\frac{\partial^2 w}{\partial s^2} \right) \frac{\partial x}{\partial s} + \frac{\partial}{\partial y} \left(\frac{\partial^2 w}{\partial s^2} \right) \frac{\partial y}{\partial s} \\ &= \cos \alpha_j \left[w_{,xxx} \cos^2 \alpha_j + 2w_{,xxy} \sin \alpha_j \cos \alpha_j + w_{,xyy} \sin^2 \alpha_j \right] \\ &\quad + \sin \alpha_j \left[w_{,xxy} \cos^2 \alpha_j + 2w_{,xyy} \sin \alpha_j \cos \alpha_j + w_{,yyy} \sin^2 \alpha_j \right] \end{aligned}$$

or

$$\frac{\partial^3 \omega}{\partial s^3} = \omega_{,xxx} \cos^3 \alpha_j + 3\omega_{,xxy} \cos^2 \alpha_j \sin \alpha_j + 3\omega_{,xyy} \sin^2 \alpha_j \cos \alpha_j + \omega_{,yyy} \sin^3 \alpha_j$$

$$\frac{\partial}{\partial s} \left(\frac{\partial^3 \omega}{\partial s^3} \right) = \frac{\partial}{\partial x} \left(\frac{\partial^3 \omega}{\partial s^3} \right) \frac{\partial x}{\partial s} + \frac{\partial}{\partial y} \left(\frac{\partial^3 \omega}{\partial s^3} \right) \frac{\partial y}{\partial s}$$

Substituting for $\frac{\partial x}{\partial s}$, $\frac{\partial y}{\partial s}$, and $\frac{\partial^3 \omega}{\partial s^3}$:

$$\begin{aligned} \frac{\partial^4 \omega}{\partial s^4} = & \cos \alpha_j \left[\omega_{,xxxx} \cos^3 \alpha_j + 3\omega_{,xxxxy} \cos^2 \alpha_j \sin \alpha_j + 3\omega_{,xxyyy} \sin^2 \alpha_j \cos \alpha_j \right. \\ & \left. + \omega_{,yyyyy} \sin^3 \alpha_j \right] \\ & + \sin \alpha_j \left[\omega_{,xxxxy} \cos^3 \alpha_j + 3\omega_{,xxyyy} \cos^2 \alpha_j \sin \alpha_j + 3\omega_{,xyyyy} \sin^2 \alpha_j \cos \alpha_j \right. \\ & \left. + \omega_{,yyyyy} \sin^3 \alpha_j \right] \end{aligned}$$

or

$$\begin{aligned} \frac{\partial^4 \omega}{\partial s^4} = & \omega_{,xxxx} \cos^4 \alpha_j + 4\omega_{,xxxxy} \cos^3 \alpha_j \sin \alpha_j + 6\omega_{,xxyyy} \cos^2 \alpha_j \sin^2 \alpha_j \\ & + 4\omega_{,xyyyy} \sin^3 \alpha_j \cos \alpha_j + \omega_{,yyyyy} \sin^4 \alpha_j \end{aligned}$$

Substituting for Q_{ne} and dividing through by DP , the boundary condition corresponding to (2-24) becomes:

$$\begin{aligned} & \omega_{,xxx} \sin \alpha_j [1 + \cos^2 \alpha_j (1 - \nu)] + \omega_{,xxy} \cos \alpha_j [1 - 3\cos^2 \alpha_j - \nu(3\sin^2 \alpha_j - 1)] \\ (2-25) \quad & + \omega_{,xyy} \sin \alpha_j [3\sin^2 \alpha_j - 1 - \nu(1 - 3\cos^2 \alpha_j)] + \omega_{,yyy} \cos \alpha_j (-1 - \sin^2 \alpha_j (1 - \nu)) \\ & + EI/DP \left[\omega_{,xxxx} \cos^4 \alpha_j + \omega_{,xxxxy} (4\cos^3 \alpha_j \sin \alpha_j) + \omega_{,xxyyy} (6\sin^2 \alpha_j \cos^2 \alpha_j) \right. \\ & \left. + \omega_{,xyyyy} (4\cos \alpha_j \sin^3 \alpha_j) + \omega_{,yyyyy} \sin^4 \alpha_j \right] = 0 \end{aligned}$$

Differentiate (2-23) and substitute (2-18):

$$(2-26) \quad GJ \frac{\partial^3 \omega}{\partial n \partial s^2} + Mnp + Qnc(HOR) = 0$$

where

$$\frac{\partial^3 \omega}{\partial n \partial s^2} = \omega_{,xxx} \sin \alpha_j \cos^2 \alpha_j + \omega_{,xxy} \cos \alpha_j (2 - 3 \cos^2 \alpha_j) \\ + \omega_{,xyy} \sin \alpha_j (3 \sin^2 \alpha_j - 2) - \omega_{,yyy} \sin^2 \alpha_j \cos \alpha_j$$

Substitute for $\frac{\partial^3 \omega}{\partial n \partial s^2}$ and divide through by DP to obtain boundary condition in Cartesian Coordinates corresponding to (2-26):

$$(2-27) \quad \omega_{,xx} [\sin^2 \alpha_j + \nu \cos^2 \alpha_j] + \omega_{,yy} [\cos^2 \alpha_j + \nu \sin^2 \alpha_j] - 2 \omega_{,xy} \sin \alpha_j \cos \alpha_j (1 - \nu) \\ + \omega_{,xxx} [GJ/DP \sin \alpha_j \cos^2 \alpha_j + HOR \sin \alpha_j (1 + \cos^2 \alpha_j (1 - \nu))] \\ + \omega_{,xxy} [GJ/DP \cos \alpha_j (2 - 3 \cos^2 \alpha_j) + (HOR) \cos \alpha_j (1 - 3 \cos^2 \alpha_j - \nu (3 \sin^2 \alpha_j - 1))] \\ + \omega_{,xyy} [GJ/DP \sin \alpha_j (3 \sin^2 \alpha_j - 2) + (HOR) \sin \alpha_j (3 \sin^2 \alpha_j - 1 - \nu (1 - 3 \cos^2 \alpha_j))] \\ + \omega_{,yyy} [-GJ/DP \sin^2 \alpha_j \cos \alpha_j + (HOR) \cos \alpha_j (-1 - \sin^2 \alpha_j (1 - \nu))] \\ = 0$$

6) Edge of Plate Connected to Simply Supported Edgebeam.

The boundary conditions for this case are:

$$(2-28) \quad w = 0$$

$$(2-29) \quad M_n(\text{plate}) = \text{Twist (beam)}$$

where, since $\frac{\partial^2 w}{\partial s^2} = 0$ along boundary of plate :

$$M_{np} = -DP[w_{,xx} + w_{,yy}] \quad (\text{see B.C's for simply supported edge conditions})$$

From free edgebeam formulation:

$$GJ \frac{\partial^3 w}{\partial n \partial s^2} + M_{np} + Q_{nc}(\text{HOR}) = 0$$

Second B.C. becomes (after dividing through by DP)

$$(2-30) \quad \begin{aligned} & w_{,xxx} \sin \alpha_j [GJ/DP \cos^2 \alpha_j + (\text{HOR})(1 + \cos^2 \alpha_j (1 - \nu))] \\ & + w_{,xxy} \cos \alpha_j [GJ/DP (2 - 3\cos^2 \alpha_j) + (\text{HOR})(1 - 3\cos^2 \alpha_j - \nu(3\sin^2 \alpha_j - 1))] \\ & + w_{,xyy} \sin \alpha_j [GJ/DP (3\sin^2 \alpha_j - 2) + (\text{HOR})(3\sin^2 \alpha_j - 1 - \nu(1 - 3\cos^2 \alpha_j))] \\ & + w_{,yyy} \cos \alpha_j [-GJ/DP \sin^2 \alpha_j + (\text{HOR})(-1 - \sin^2 \alpha_j (1 - \nu))] \\ & - [w_{,xx} + w_{,yy}] = 0 \end{aligned}$$

CHAPTER III

AUTOMATIC ASSEMBLAGE OF
DIFFERENCE EQUATIONS AT THE GRIDPOINTS

The assemblage of the molecules for the gridpoints on the plate can be thought of as being generated by:

- a) The boundary conditions (for those points in the vicinity of the boundary.)
- b) The surrounding points in the interior of the plate.

The manner in which the boundary conditions and internal gridpoints combine to form the molecule will now be described in detail.

1. Internal Points and Boundary Points

Each gridpoint in the plate is assumed to be affected by 36 other gridpoints with relative numbers shown in figure (17). The absolute number of each of these surrounding gridpoints relative to that of the central gridpoint is given in Table 6.

The computer will first classify each gridpoint in the plate as to whether it is an interior point or a boundary point. A boundary point is defined as a central gridpoint with one or more of its relative points shown in figure (17) lying off the surface of the plate. Analogously, an interior point is a central gridpoint that has all 36 of its relative points lying on the surface of the plate.

If a point is classified as interior, the standard operators shown in figure (18) will be used. The remainder of this chapter will be devoted to obtaining the finite difference molecule for a boundary point.

TABLE 6

ABSOLUTE COORDINATES OF POINTS RELATIVE TO CENTRAL GRIDPOINT

Relative Point	Absolute Coordinate	Relative Point	Absolute Coordinate
1	LP(I)	19	LP(I)-201
2	LP(I)+1	20	LP(I)-98
3	LP(I)-1	21	LP(I)+98
4	LP(I)+100	22	LP(I)+202
5	LP(I)-100	23	LP(I)-202
6	LP(I)+101	24	LP(I)+198
7	LP(I)-101	25	LP(I)-198
8	LP(I)+99	26	LP(I)+3
9	LP(I)-99	27	LP(I)-3
10	LP(I)+2	28	LP(I)+300
11	LP(I)-2	29	LP(I)-300
12	LP(I)+200	30	LP(I)+103
13	LP(I)-200	31	LP(I)-103
14	LP(I)+102	32	LP(I)+299
15	LP(I)-98	33	LP(I)-299
16	LP(I)+199	34	LP(I)+301
17	LP(I)-199	35	LP(I)-301
18	LP(I)+201	36	LP(I)+97
		37	LP(I)-97

2. Boundary Conditions

The method in which the boundary conditions are taken into account will now be explained.

Since the basic plate equation ($\nabla^4 w = \frac{q}{Dp}$) is a 4th order differential equation, 2 boundary conditions are needed for each side. These boundary conditions (for a given side), are classified as follows:

- 1) Simple Boundary Condition - Boundary Condition with lower derivative
- 2) Complicated Boundary Condition - Boundary Condition with higher derivative

It is seen that each side will have one simple boundary condition and one complicated boundary condition.

The governing criteria as to how many boundary conditions will be used in formulating the operator for a given central point, is the perpendicular distance from that point to the side of any contour. (see figure (19a)).

Since the coordinates of the corner points of each side, and the coordinates of the central point are given, d_i can be easily computed.

The magnitude of d_i governs just how much influence the boundary conditions will have on the operator for the central gridpoint. Four cases are considered:

- (1) $d_i > 2H$:

No boundary condition is formulated here.

(2) $\sqrt{2}H < d_i < 2H$:

The simple boundary condition is formulated at the closest boundary point only. There is a maximum of 1 boundary condition for this case (figure (19b)).

(3) $H < d_i < \sqrt{2}H$:

The simple boundary condition is formulated at the closest point and at points on either side of the closest point, a distance H away. There is a maximum of 3 boundary conditions for this case. (see figure (19c)).

(4) $d_i < H$:

The simple and complicated boundary conditions are formulated at the closest point, and the simple boundary condition is formulated at points on either side of the closest point, a distance H away. There is a maximum of 4 boundary conditions for this case. (see figure (19d)).

Note that in cases (2), (3), and (4), the boundary conditions are formulated at points a , b , and c only if these points lie on the side. To illustrate, consider the central point shown in figure (20).

Now, point C_i does not fall on side i . Therefore, in assembling the operator for central point x , we would consider the simple B.C. of side i at points a_i and b_i . Also, for side j , we would consider the simple B.C.'s at points a_j , b_j , and c_j , and the complicated B.C. at b_j . This results in a total of 6 B.C.'s to be considered in the formulation of the operator at point x .

c. Method of Formulation of Molecules for Boundary Points.

The method of determining the molecule for a boundary point can best be illustrated by the example shown in figure (21). In this the boundary conditions and distances to the sides are given below:

a) BOUNDARY CONDITIONS:

Side 1: Fixed

Side 2: Simply supported

b) DISTANCES TO SIDES

$$d_1 = 0.62H$$

$$d_2 = 0.40H$$

From the criteria of the previous section, the boundary conditions to be considered in the formulation of the $\nabla^4 w$ operator at point 1 are:

Side 1:

$$b_1: \quad w = 0$$

$$w_{,x} \sin \phi_1 - w_{,y} \cos \phi_1 = 0$$

$$c_1: \quad w = 0$$

Side 2:

$$b_2: \quad w = 0$$

$$w_{,xx} + w_{,yy} = 0$$

$$c_2: \quad w = 0$$

Since points Q_1 and Q_2 do not fall on sides 1 and 2 respectively, no boundary conditions are considered at these points. Therefore, 6 boundary conditions to be incorporated

into the operator for point 1.

$\nabla^4 w_i$ will be expressed as a linear combination of the boundary conditions, the displacements, w , at adjacent points, and if necessary, the values of $\nabla^4 w$ at adjacent points (called multi-point operators). Each of these quantities will be expanded in a Taylor Series about central point 1. The number of these quantities that are to be considered depends on the desired accuracy, that is, on the order of the non-vanishing derivative contained in the expansion.

For the plate problem accuracy up to the sixth derivative is desired. Therefore, the first 21 terms in the Taylor Series expansion for w_i about the central gridpoint 1 must be identically satisfied. In order to satisfy these 21 conditions, $\nabla^4 w_i$ must be expressed as a linear combination of a total of 21 boundary conditions, displacements, and multi-point operators.

In general, there will be N boundary conditions in the formulation of the operator for point 1. Therefore, we need $21-N$ interior conditions, in general. However, the case may arise in which there are less than $21-N$ points lying in the interior of the plate. For this case, the computer will proceed in the following manner:

- 1) Determine the expansion for the displacement at all points adjacent to central point 1 lying in the interior of the plate.
- 2) Multi-Point Operators: Determine the expansion for $\nabla^4 w$ at as many points adjacent to point 1 as are needed

to bring the total number of interior conditions to 21-N. The computer first expands $\nabla^4 w$ at the adjacent point closest to 1, then at successively further points until enough interior points are considered. (We know from the plate equation that at any point m in the interior of the plate, $\nabla^4 w_m = \frac{q_m}{DP}$ where q_m is the load per unit at point m).

Now this example has a total of 6 boundary conditions. Therefore, an additional 15 interior conditions are needed in order that the error be in the sixth derivative of the expansion. However, from Fig. 21, it is seen that there are only 9 points adjacent to point 1 lying on the plate surface. Therefore, expansions for $\nabla^4 w$ at the 6 adjacent points nearest to point 1 will also have to be made. In equation (1) below, the coefficients of $A_{16} - A_{21}$ are the multi-point operators.

The equation for $\nabla^4 w_1$ can be written as:

$$\begin{aligned}
 & A_1 (\text{SIMPLE B.C. AT B1}) + A_2 (\text{SIMPLE B.C. AT C1}) + A_3 (\text{COMPL. B.C. AT B1}) \\
 & + A_4 (\text{SIMPLE B.C. AT B2}) + A_5 (\text{SIMPLE B.C. AT C2}) + A_6 (\text{COMPL. B.C. AT B2}) \\
 (3-1) \quad & + A_7 w_1 + A_8 w_5 + A_9 w_7 + A_{10} w_{13} + A_{11} w_{17} + A_{12} w_{19} + A_{13} w_{29} \\
 & + A_{14} w_{33} + A_{15} w_{35} + A_{16} (q_5/DP) + A_{17} (q_7/DP) + A_{18} (q_{13}/DP) \\
 & + A_{19} (q_{17}/DP) + A_{20} (q_{19}/DP) + A_{21} (q_{29}/DP) \\
 & = \frac{\partial^4 w_1}{\partial x^4} + 2 \frac{\partial^4 w_1}{\partial x^2 \partial y^2} + \frac{\partial^4 w_1}{\partial y^4} \left(= \frac{q_1}{DP} \right)
 \end{aligned}$$

where A_1, \dots, A_6 are constants. Note that since the boundary conditions are homogeneous, the coefficients of A_1, A_2, \dots, A_6 in equation (3-1) above, are zero.

The left side of equation (1) is now expanded in a series about point 1 and the coefficients of like derivatives of ω_1 on each side of the equation are equated. This results in the required 21 equations necessary for the operator to be accurate up to the sixth derivative of the series expansion.

Expanding the left side, we get

$$(3-2) \quad A_1[\dots] + A_2[\dots] + \dots + A_{21}[\dots] = \frac{\partial^4 \omega_1}{\partial x^4} + 2 \frac{\partial^4 \omega_1}{\partial x^2 \partial y^2} + \frac{\partial^4 \omega_1}{\partial y^4}$$

which can be written in matrix form as

$$(3-3) \quad \left[\begin{array}{c} \zeta \\ \text{(CO-EFFICIENT MATRIX)} \end{array} \right] \left\{ \begin{array}{c} A_1 \\ \vdots \\ A_{21} \end{array} \right\} = \left\{ \begin{array}{c} 0 \\ \vdots \\ 0 \\ 0 \\ 0 \\ 0 \end{array} \right\}$$

Note that the first 6 columns of the coefficient matrix

are the Taylor Series expansions for the boundary conditions, the next 9 columns are the expansions for the displacements at the interior points, and the final 6 columns are the expansions for $\nabla^4 w$ at the 6 adjacent points nearest to w_i .

In addition to deflections, it is also desirable to determine the bending moments, M_{xx} and M_{yy} , and the twisting moment, M_{xy} , at each gridpoint. This is done in the same way as previously described for deflections. We determine M_{xx} , M_{yy} , and M_{xy} at point 1 as a linear combination of the boundary conditions, the displacements at adjacent gridpoints, and, if necessary, the values of $\nabla^2 w$ at adjacent gridpoints. From this it is seen that the equations for the A's for these 3 cases will be of the same form as for the determination of deflections. In fact the coefficient matrix for the A's will be exactly the same as in equation (3-3); only the right hand sides of the equations will be different.

In summary, we see that for each interior gridpoint, we have 4 different sets of eq'ns for the constants A_i , 1 each for $\nabla^2 w$, $\frac{M_{xx}}{DP}$, $\frac{M_{yy}}{DP}$, and $\frac{M_{xy}}{DP}$. However the left side of all 4 of these sets of equations is the same, only the right side is changed.

- 3) Now, for boundary points, equation (3-4) must be solved for a set of A's corresponding to each of M_{xx} , M_{yy} , and M_{xy} . The standard operators for these moments at interior points are given in figures (18b)-(18d).
- 4) One of the molecules for the moments are known. The actual values of M_{xx} , M_{yy} , and M_{xy} at each gridpoint can be obtained by back substituting the displacements.

Error Analysis

It has been stated previously that the plate analysis described herein will be accurate up to the sixth derivative. This accuracy will be satisfied except for the following limitations of the method.

- a) It is possible that, for a central point located very close to a corner of the plate, the 37 points given in figure (17) will not give a sufficient number of interior conditions. For example, consider central point 1 as pictures in figure (22).

Assuming that the perpendicular distance from point 1 to sides 1 and 2 is less than H in each case, we have 6 boundary conditions. Then, 15 additional interior conditions are needed. However, we see that only 6 points adjacent to point 1 lie in the interior of the plate. Thus even if we consider both the displacement expansion and many point operator at each of these interior points, we get a total of 17 conditions - while 21

are actually needed. Therefore, for the case of figure (22), the error in the analysis will occur in the fifth derivative.

NOTE:

The case in figure (22), is quite extreme and probably will not occur often in practice.

- b) It is possible that one or more of the columns of the coefficient matrix C (in the determination of the A'S) is linearly dependent on the other columns. If this occurs, it is possible that a solution for the A'S will not be able to be found. To safeguard against this, the computer will determine 30 columns in C , and will consider the first 21 linearly independent columns when solving for . Since each column in C corresponds to a Taylor Series expansion for either the boundary conditions, displacements at interior points, or multi-point operators at the interior points, this means that the computer is making 30-N expansions at interior points, instead of 21-N (Where N = number of boundary conditions).

CHAPTER IV

DETERMINATION OF FINITE DIFFERENCE EQUATIONS FOR REACTIONS
AND/OR DISPLACEMENTS AT POINTS ALONG THE BOUNDARY OF THE PLATE

A. Quantities to be Computed at Boundary

The reactions and/or displacements at the boundary will be computed at points listed in LBPE, whose coordinates are given in XBPE and YBPE. The side on which each point is located is given by LBPSE.

The actual quantities to be computed at each boundary point depends on the boundary condition of the side on which the boundary point is located. The boundary condition for each side of the plate is given as input in MCONS(4,NS). For each boundary condition, the quantities to be computed at each point along the boundary are as follows:

1) Fixed Edge

a) Bending Moment, M_n :

$$M_n = -DP \left[\frac{\partial^2 w}{\partial n^2} + \nu \frac{\partial^2 w}{\partial s^2} \right]$$

where, along the fixed edge, $\frac{\partial^2 w}{\partial s^2} = 0$.

Final expression for M_n becomes:

$$(4-1) \quad M_n = -DP [w_{,xx} + \nu w_{,yy}]$$

b) Transverse shear,

$$Q_{ne} = DP \frac{d}{dn} \left[\frac{\partial^2 w}{\partial n^2} + (2-\nu) \frac{\partial^2 w}{\partial s^2} \right]$$

Again setting $\frac{\partial^2 w}{\partial s^2} = 0$ along the boundary and substituting for $\frac{\partial^2 w}{\partial n^2}$, the expression for transverse shear becomes:

$$(4-2) \quad Q_{ne} = DP \left[w_{,xxx} \sin^3 \alpha_i - 3w_{,xxy} \sin^2 \alpha_i \cos \alpha_i + 3w_{,xyy} \sin \alpha_i \cos^2 \alpha_i - w_{,yyy} \cos^3 \alpha_i \right]$$

2) Simply Supported Edge

The transverse shear, Q_{ne} , will be the only quantity computed for this boundary condition. The expression is exactly the same as that in the fixed edge.

3) Free Edge

The vertical displacement, w , will be the only quantity computed for this boundary condition.

4) Elastically Restrained Edge

(free edge with rotational spring and translational spring)

a) Restrained Against Rotation

The vertical displacement w , and bending moment M_n will be computed, where:

$$(4-3) \quad M_n = SCR [w_{,x} \sin \alpha_i - w_{,y} \cos \alpha_i]$$

b) Restrained Against Translation

The transverse shear, Q_{ne} is to be computed and is given by:

$$(4-4) \quad Q_{ne} = -(SCD)\omega$$

5) Edge of Plate Attached to Free Edgebeam

a) Torsional Moment of Beam

$$M_{sb} = GJ \frac{\partial^2 \omega}{\partial n \partial s} = GJ \left[\frac{\partial}{\partial x} \left(\frac{\partial \omega}{\partial n} \right) \frac{\partial x}{\partial s} + \frac{\partial}{\partial y} \left(\frac{\partial \omega}{\partial n} \right) \frac{\partial y}{\partial s} \right]$$

or, upon substituting for $\frac{\partial \omega}{\partial n}$, $\frac{\partial x}{\partial s}$, and $\frac{\partial y}{\partial s}$:

$$(4-5) \quad M_{sb} = GJ \left[\omega_{,xx} \sin \alpha_i \cos \alpha_i + \omega_{,xy} (2 \sin^2 \alpha_i - 1) - \omega_{,yy} \sin \alpha_i \cos \alpha_i \right]$$

b) Bending Moment of Beam:

$$M_{nb} = -EI_n \frac{\partial^2 \omega}{\partial s^2}$$

or upon substitution:

$$(4-6) \quad M_{nb} = -EI_n \left[\omega_{,xx} \cos^2 \alpha_i + 2 \omega_{,xy} \sin \alpha_i \cos \alpha_i + \omega_{,yy} \sin^2 \alpha_i \right]$$

c) Shear of Beam:

$$F_z = -EI_n \frac{\partial^3 \omega}{\partial s^3}$$

$$(4-7) \quad F_z = -EI\eta \left[\omega_{,xxx} \cos^3 \alpha_i + 3\omega_{,xxy} \cos^2 \alpha_i \sin \alpha_i + 3\omega_{,xyy} \sin^2 \alpha_i \cos \alpha_i + \omega_{,yyy} \sin^3 \alpha_i \right]$$

d) compute transverse deflection, ω .

6) Edge of Plate Connected to Simply-Supported Edgebeam

a) Torsional moment of beam:

$$(4-8) \quad M_{sb} = GJ \left[\omega_{,xx} \sin \alpha_i \cos \alpha_i + \omega_{,xy} (2\sin^2 \alpha_i - 1) - \omega_{,yy} \sin \alpha_i \cos \alpha_i \right]$$

b) Shear/unit width of plate = Q_{np} .

(Distributed load transmitted from plate to edge beam)

$$(4-9) \quad Q_{np} = DP \left[\omega_{,xxx} \sin^3 \alpha_i - 3\omega_{,xxy} \sin^2 \alpha_i \cos \alpha_i + 3\omega_{,xyy} \sin \alpha_i \cos^2 \alpha_i - \omega_{,yyy} \cos^3 \alpha_i \right]$$

B. Method of Computation of Boundary Quantities

This can best be illustrated by an example. Consider point I in Figure 23, which lies along a fixed side J.

Since side J is fixed, the bending moment, M_n , and the transverse shear, Q_{ne} , will be computed at point I. This is done in a manner similar that employed in analyzing the interior gridpoints in Chapter III.

First, the force displacement relations are utilized to express the moment and shear at point I as a function of derivatives of the displacement at I.

$$a) \quad M_n = -DP[\omega_{,xx} + \omega_{,yy}]$$

$$b) \quad Q_n = DP[\omega_{,xxx} \sin^3 \alpha_i - 3\omega_{,xxy} \sin^2 \alpha_i \cos \alpha_i + 3\omega_{,xyy} \sin \alpha_i \cos^2 \alpha_i - \omega_{,yyy} \cos^3 \alpha_i]$$

Q_n and M_n at point I will be determined as a linear combination of the boundary conditions, the displacements, ω , at the neighboring interior gridpoints, and, if necessary, the multi-point operators, $(\nabla^4 \omega)$, at as many interior gridpoints as are needed to give the desired accuracy. The boundary conditions, displacements, and multi-point operators are then expanded in a Taylor Series about point I, and coefficients of like derivatives of ω_I on each side of the equations for Q_n & M_n are equated.

To be consistent with the formulation of Chapter III, final accuracy is required up to the sixth derivative of the Taylor Series expansions.

a) Boundary Conditions:

For a fixed edge, the boundary conditions are:

Simple boundary condition: $\omega = 0$

Complicated boundary condition: $\omega_{,x} \sin \alpha_i - \omega_{,y} \cos \alpha_i = 0$

Now, for all points on all sides, the following B.C.'s will be considered:

- 1) Simple boundary condition at point I.
- 2) Simple boundary condition at point A, a distance above point I on side J
- 3) Simple boundary condition at point C, a distance below point I on side J.
- 4) Complicated boundary condition at point I.

However, inasmuch as point A lies off of side J, as shown in figure (23), we cannot use the boundary condition at this point. Therefore, we have 3 boundary conditions, and need 18 additional interior conditions to result in the total of 21 required for the desired accuracy.

b) Interior Conditions

The numbering of the points shown in figure (23) is determined by choosing the central gridpoint (relative number = 1) as that interior gridpoint closest to the boundary point I. The other gridpoints to be considered are those with the relative numbering given in figure (17) which lie in the interior of the plate.

From figure (23), it is seen that a total of 9 of the gridpoints of figure (17) lie in the plate. Therefore expansions are needed for both ω and $\nabla^4 \omega$ at all 9 of these points in order to result in the required 18

interior conditions. These expansions will be in terms of the displacement at point I and all derivatives of the displacement at I up to the sixth derivative. It can be seen that, in general, the difference in x and y coordinates between point I and the various internal gridpoints (Δx and Δy) will not be integral multiples of the grid size H , as was the case in Chapter III.

The expansion for the moment at point I can be written as follows:

$$\begin{aligned}
 & A_1[\omega_{AT I}] + A_2[\omega_{AT C}] + A_3[(\omega_{yx} \sin \alpha_i - \omega_{iy} \cos \alpha_i)_{AT I}] \\
 & + A_4 \omega_1 + A_5 \omega_5 + A_6 \omega_7 + A_7 \omega_{13} + A_8 \omega_{17} + A_9 \omega_{19} + A_{10} \omega_{29} \\
 (4-10) \quad & + A_{11} \omega_{33} + A_{12} \omega_{35} + A_{13}(q_1/DP) + A_{14}(q_5/DP) + A_{15}(q_7/DP) \\
 & + A_{18}(q_{19}/DP) + A_{19}(q_{29}/DP) + A_{20}(q_{33}/DP) + A_{21}(q_{35}/DP) \\
 & = -DP[\omega_{I,xx} + \omega_{I,yy}]
 \end{aligned}$$

where, since the boundary conditions are homogeneous, the coefficients of A_1 , A_2 , and A_3 are zero. Also note that the coefficients of A_{13} - A_{21} are multi-point operators. A similar expression can be written for the transverse shear force.

As in Chapter III, the left side of equation (4-10) is expanded in a Taylor Series and coefficients of like

derivatives of the displacement at I on the left and right sides are equated. From this it is seen that the left side of the matrix equation will have exactly the same coefficient matrix for both the moment and the shear - and only the right side of the equation will be different.

In matrix form, the series of equations corresponding to equating coefficients of like displacement derivatives can be written in the following form:

$$(4-11) \quad [C] \{A\} = \left\{ \begin{array}{l} \text{(a)} \\ 0 \\ 0 \\ 0 \\ 0 \\ -1 \\ 0 \\ 0 \\ 0 \\ 0 \\ 0 \\ 0 \\ 0 \\ 0 \\ \dots \\ 0 \end{array} \right\} \left\{ \begin{array}{l} \text{(b)} \\ 0 \\ 0 \\ 0 \\ 0 \\ 0 \\ 0 \\ \sin^2 \alpha_j \\ -3 \sin^2 \alpha_j \cos \alpha_j \\ 3 \sin \alpha_j \cos^2 \alpha_j \\ -\cos^3 \alpha_j \\ 0 \\ \dots \\ 0 \end{array} \right\}$$

in which column (a) is the right hand side corresponding to M_n , and column (b) is the right hand side corresponding to Q_{ne} .

The coefficient matrix C in equation (4-11) can now be inverted in order to determine the A's for each right hand side. Once the A's are known, the bending moment and effective shear at point I can be written

as:

$$(4-12) \quad \begin{aligned} M_{II} \text{ AT I} &= \sum_i^{\text{displ.}} A_i \omega_i + C_1 \\ Q_{II} \text{ AT I} &= \sum_j^{\text{displ.}} A_j \omega_j + C_2 \end{aligned}$$

where C_1 and C_2 are the effects of the multi-point operators, and, once the A's are determined, are known constants.

$$(4-13) \quad \begin{aligned} &A_{13} [q_1/DP] + A_{14} [q_5/DP] + A_{15} [q_7/DP] + A_{16} [q_{13}/DP] \\ &+ A_{17} [q_{17}/DP] + A_{18} [q_{18}/DP] + A_{19} [q_{20}/DP] + A_{20} [q_{33}/DP] \\ &+ A_{21} [q_{35}/DP] \end{aligned}$$

The A's in equation (4-13) correspond to the first hand side in equation (4-11). The expression for C_2 will be of the same form as (4-13), except that the A's will correspond to the second right hand side in (4-11). It is obvious that as soon as the deflections at the interior gridpoints are determined, the moment and shear at point I can be computed directly. This will be demonstrated in Chapter IV.

As in Chapter III, it is desirable to have more than 21 columns in \tilde{C} in case any of the columns are linearly dependent. In fact, the computer will calculate a maximum of 30 columns for \tilde{C} , and will consider the first 21 linearly independent

columns in computing the A's (as was done in Chapter II). For this particular example, there is a maximum of 21 columns in \mathcal{C} . Therefore, if any of these columns are linearly dependent, the error will result in the fifth derivative, rather than the sixth.

Finally, it is interesting to note that as the boundary point approaches a corner, this plate analysis will give results that are somewhat inconsistent with experimental results. This is because of the fact that the standard plate theory predicts a concentrated corner force, while a more gradual increase in reaction intensity with decreasing distance to the corner actually occurs.

CHAPTER V

SOLUTION, BACKSUBSTITUTION AND OUTPUT FOR PLATE ANALYSIS

A. Solution of System of Finite Difference Equations

The large system of equations involving the displacements at each gridpoint as the unknowns will be solved using a Gauss elimination technique on the partitioned band-matrix. This large system of equations is given by RDE(I) in the flowchart for Link II. A detailed description of this method of solution now follows:

1) Band Matrix Character of System of Equations.

In part I, it was stated that, in the solution of the large system of equations, the gridpoints would be rearranged parallel to the smallest side of the rectangle enclosing the plate (upward & to the left). The reason for this will now be explained.

Consider the plate shown in figure (24), and assume we are writing the operator for point I in the interior of the plate.

It is seen that the shaded portion of figure (24) corresponds to the maximum zone of influence of point I; that is, the gridpoints contained in this shaded region could be included in the difference operator for point I, but all gridpoints outside of the shaded region will definitely not be

included in the operator for point I.

Now, let us consider the form of the difference operator for point I. It was shown in Part I, that a maximum of MDIM gridpoints can be placed along the plate parallel to the smaller sides of the enclosing rectangle. Therefore, in figure (24), a maximum of MDIM gridpoints can be placed along the distances IA+BC, DE+FG, and HJ+KL, and 2 additional gridpoints can be placed along LN. Since the gridpoints are to be listed in the final system of equations from IA-BC-DE--FG-HJ-KL-LN, we see that there will be a maximum number of $3MDIM+2$ gridpoints to the right of point I in the final difference eq'ns. Due to the symmetry of the shaded area of figure (13), there will also be a maximum total of $3MDIM+2$ gridpoints to the left of point I, resulting in a total of $6MDIM+4$ terms in the difference equation for point I. Therefore, we see that the final set for equations will be in the form of a band matrix, with the maximum width of the band = $6MDIM+4$. See figure (25) for an illustration of the band matrix character of the difference equations.

Now, it is seen that by listing the gridpoints parallel to the shortest side of the enclosing rectangle, we have made the final system of equations into a band matrix, and have minimized the width of the band. This will greatly diminish the complexity of solving this large system of simultaneous equations.

Observe that within the above band there will originally be 3 corridors of zeros (corresponding to regions AA'+BB', DE'=FG', and H'J+KL in figure (24)). However, since these corridors fill up once the Gauss Elimination procedure begins, they cannot be utilized to shorten the amount of computation required in solving the equations.

2) Gauss Elimination Procedure in Solving a Partitioned Band Matrix

Due to the extremely large size of the system, it is necessary to partition the resulting band matrix. A detailed discussion of the mathematics involved is given in reference (4).

B. Output for Interior Gridpoints (for each loading condition)

As previously described, the computer will first solve the large system of equations for the displacements at the interior points.

After determining the displacements, the moments M_{xx} , M_{yy} and M_{xy} at each gridpoint can be computed by back substitution into the appropriate difference equations. These moments will enable the engineer to determine the state of stress at any point in the plate.

Finally, the principal moments M_1 and M_2 and the angle the maximum principal moment makes with the positive x axis, ϕ , can be determined at any point on the surface of the plate. At any point on the plate, the stresses are given by:

$$\sigma_x = \pm \frac{6M_{xx}}{t^2}; \quad \sigma_y = \pm \frac{6M_{yy}}{t^2}; \quad \tau_{xy} = \pm \frac{6M_{xy}}{t^2}$$

Since t (plate thickness) is constant, the bending and twisting moments at any point on the plate are constant multiples of the normal and shear stresses respectively at that point on the plate surface.

From this, the Mohr Circle Theory for combined stresses at a point on an elastic body can be readily extended to consider a point of "combined moment" at a point on a plate, and can be utilized to determine the principal moments at that point on the plate.

It is now desirable to determine a sign convention for the Mohr Circle for moments. The positive direction for moments that has been used in the plate analysis is shown in figure (3). These moments will be assumed to be represented by the Mohr Circle of figure (26a), and by the moment vectors of figure (26b).

The positive moment vector sign convention of Fig. (26b) corresponds to the directions of the stresses on the bottom fiber of the plate, caused by the moments shown in Fig. (3).

From Fig. (26b), the following equations for principal moments are obtained:

$$M_1 = \frac{M_{xx} + M_{yy}}{2} + \left[\left(\frac{M_{xx} - M_{yy}}{2} \right)^2 + M_{xy}^2 \right]^{1/2}$$

$$M_2 = \frac{M_{xx} + M_{yy}}{2} - \left[\left(\frac{M_{xx} - M_{yy}}{2} \right)^2 + M_{xy}^2 \right]^{1/2}$$

Now, from Fig. (26c), we define the angle ϕ as the angle that M_1 makes with the positive x axis. ϕ is computed from:

$$M_{xx} > M_{yy} : \quad \phi = \frac{1}{2} \text{TAN}^{-1} \left[\frac{2M_{xy}}{M_{xx} - M_{yy}} \right]$$

$$M_{yy} > M_{xx} : \quad \phi = \frac{1}{2} \text{TAN}^{-1} \left[\frac{2M_{xy}}{M_{yy} - M_{xx}} \right]$$

where ϕ is positive if clockwise.

For interior gridpoints the output will have the following

form:

LOADING CONDITION 1

COORDINATE	DISPL. (In)	MXX ($\frac{\text{lb-in}}{\text{in}}$)	M ($\frac{\text{lb-in}}{\text{in}}$)	MYX ($\frac{\text{lb-in}}{\text{in}}$)	MY ($\frac{\text{lb-in}}{\text{in}}$)	M1 ($\frac{\text{lb-in}}{\text{in}}$)	M2 ($\frac{\text{lb-in}}{\text{in}}$)	PHI (RAD)
0103	XXX	XXX	XXX	XXX	XXX	XXX	XXX	XXX
XXXX	XXX	XXX	XXX	XXX	XXX	XXX	XXX	XXX

XXXX

LOADING CONDITION 2

COORDINATE	DISP. (IN)	MXX ($\frac{\text{lb-in}}{\text{in}}$)	MYX ($\frac{\text{lb-in}}{\text{in}}$)	MY ($\frac{\text{lb-in}}{\text{in}}$)	M1 ($\frac{\text{lb-in}}{\text{in}}$)	M2 ($\frac{\text{lb-in}}{\text{in}}$)	PHI (RAD)
0103	XXX	XXX	XXX	XXX	XXX	XXX	XXX
XXXX	XXX	XXX	XXX	XXX	XXX	XXX	XXX

XXXX

XXXX

b) Boundary Points (for each loading condition)

Having determined the displacements at each interior gridpoint, the required reactions and/or displacements at each boundary point can be determined by back substitution into RBP1(I), RBP2(I), RBP3(I), RBP4(I). Since the output for each point depends on the boundary condition of the side where the point is located, the output will be of the following

form:

SIDE 15 FIXED EDGE

COORDINATE	(lb/in)	MN (ln-in/in)
------------	---------	------------------

xxx	xxx	xxx
xxx	xxx	xxx

SIDE 16 FREE EDGE BEAM

COORDINATE	MSB (lb-in)	MNB (lb-in)	FZ (lb)	DISPL (in)
------------	----------------	----------------	------------	---------------

xxx	xxx	xxx	xxx	xxx
xxx	xxx	xxx	xxx	xxx

D. Computer Programming of the Plate Analysis

In addition to the formulation of the plate analysis, it was also attempted to program the Input Phase and Assemblage of Molecules Phase of the problem on an I.B.M. 7040 computer. The results of this programming effort will now be described in detail.

PART I - INPUT, SORTING, AND PRELIMINARY CALCULATIONS

This phase of the programming effort is as described in Chapter I. The flowchart for this link is given in figure (27-1) and the source program for this link is given in Section IX-A.

It is important to note that this link, termed LINK1, makes use of subroutine MATCH, a previously developed program, in converting the boundary condition input (in MCONS) to numerical data. Therefore, it is important to include a binary deck of MATCH when loading LINK1 on the computer.

A feature of LINK1 is that it prints out all data previously fed in as input. This enables the user to check his data for numerical mistakes.

PART 2 - AUTOMATIC ASSEMBLAGE OF DIFFERENCE EQUATIONS

Originally, it was intended to have this portion of the program assembled as one link, the flowchart for which is given in figure (27-2). However, early programming attempts revealed that this original link far exceeded the storage capacity of the computer. Therefore, it was decided to break the link given in figure (27-2) into two separate links.

The first of these new links, termed LINK2, will perform the following calculations:

- a) The computer first classifies each gridpoint on the plate as to whether it is a boundary point or an interior point. As described in Chapter II, the standard operators can be used for interior points, while new molecules will have to be formulated for the boundary points.
- b) The perpendicular distance from the gridpoint to each side in the plate is then computed.
- c) The computer then assembles that portion of the matrix corresponding to the series expansions for the boundary conditions of sides less than $2H$ away from the gridpoint. It is assumed that each gridpoint has up to 8 boundary condition expansions, The total number of these boundary condition expansions, NBC, is also computed.
- d) Finally, that portion of the AW matrix corresponding to the boundary conditions and the number of boundary conditions, NBC, is stored on tape.

e) In this link, if sense switch 5 is down, the computer will print out the distance from the gridpoint to each side, the number of boundary conditions, NBC, and the first 8 columns of the matrix (containing the boundary condition expansions.) If sense switch 5 is left up, this printout will be deleted.

The other portion of Part 2, termed LINK3 in the computer, performs the remaining calculations involved in assembling the gridpoint molecules as follows:

- a) The computer assembles the standard molecules for all interior gridpoints.
- b) For boundary points, the portion of the AW matrix corresponding to the boundary conditions is read in from the tape on which it was stored. The remaining displacement and multi-point operator expansions necessary to fill 30 columns in the AW matrix are then carried out.
- c) The right hand sides corresponding to $\nabla^4\omega$, M_{xx} , M_{yy} , and M_{xy} are then filled in.
- 8 d) The AW matrix is inverted to obtain the molecules for $\nabla^4\omega$, M_{xx} , M_{yy} , and M_{xy} . These molecules are then stored on tape.
- e) Steps (b) - (d) are repeated for each boundary point.
- f) Finally, the band matrix corresponding to the calculation of the gridpoint deflections is assembled and stored. Due to the large size of this matrix, it is necessary to store it on 2 separate tapes.

g) In LINK3, if sense switch 6 is down, the computer will print the complete AW matrix prior to its inversion. If sense switch 6 is left up, this printout will not occur.

The output for Part 2 consists of a listing of the molecules for V^u , M_{xx} , M_{yy} , and M_{xy} for each gridpoint in the plate. This program also computes and prints out the effective load for each loading condition to which the plate is subjected. The effective load at point I is computed as:

$$q_{\text{eff}}(I) = q(I) - \sum_{\substack{\text{multi-} \\ \text{point} \\ \text{operators}}} A_j (V^u \omega)_j$$

The source programs for LINK2 and LINK3 are given in Section IX-D.

It remains to program the portion of the plate analysis corresponding to the computation of reactions and displacements along the boundary, and that portion of the analysis that inverts the band matrix and back substitutes to obtain the moments at each gridpoint. However, the flowcharts corresponding to these phases of the analysis have been worked out and are given in figures (27-3) and (27-4).

E. Conclusions

The following conclusions and suggestions for future work can now be stated as follows:

1) The finite difference plate analysis presents a far more accurate method of obtaining molecules for gridpoints in the vicinity of the boundary than does the standard method. The actual criteria for distance from the gridpoint to each side used in this particular analysis is somewhat arbitrary; however the method itself is systematic and theoretically sound.

2) The generality of plate shapes, loadings, and boundary conditions that can be handled by this method of analysis should render it invaluable as a research and analysis tool. Therefore, it is strongly recommended that the programming of this plate analysis, begun as a part of this thesis, be continued to completion.

VI

FIGURES

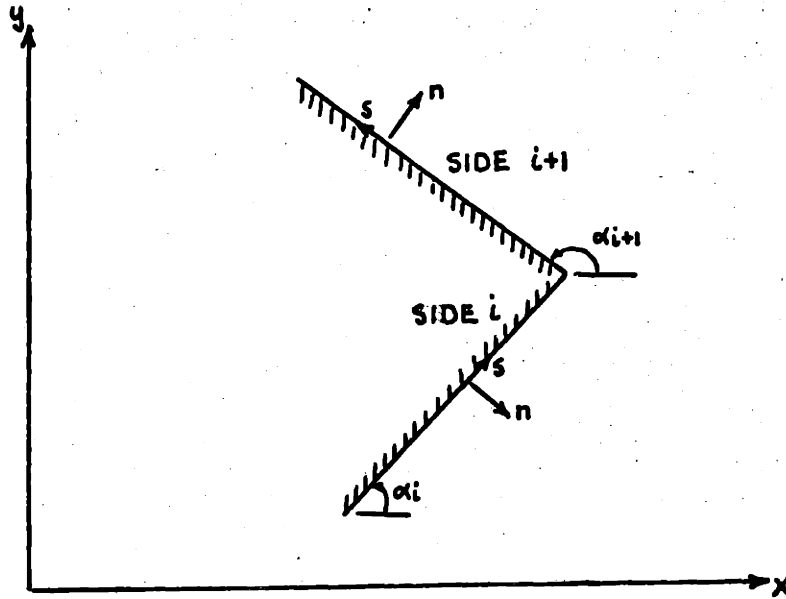

a) POSITIVE DIRECTION
FOR EXTERIOR CONTOUR

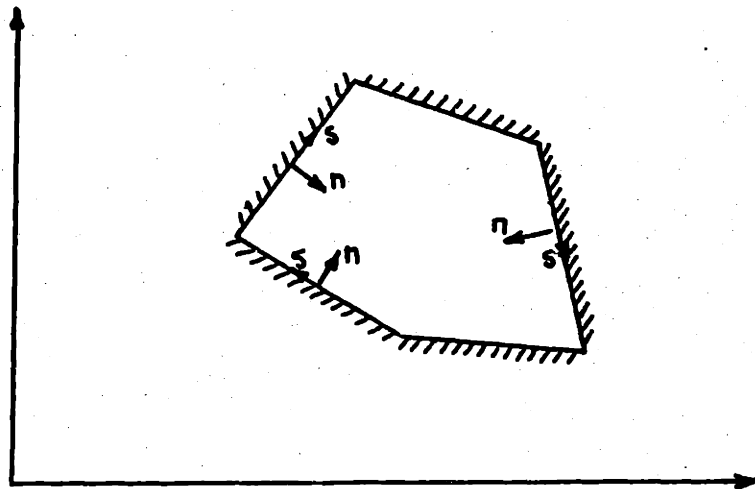

b) POSITIVE DIRECTION
FOR INTERIOR CONTOUR

FIGURE 2
ASSUMED POSITIVE DIRECTIONS
FOR PLATE CONTOURS

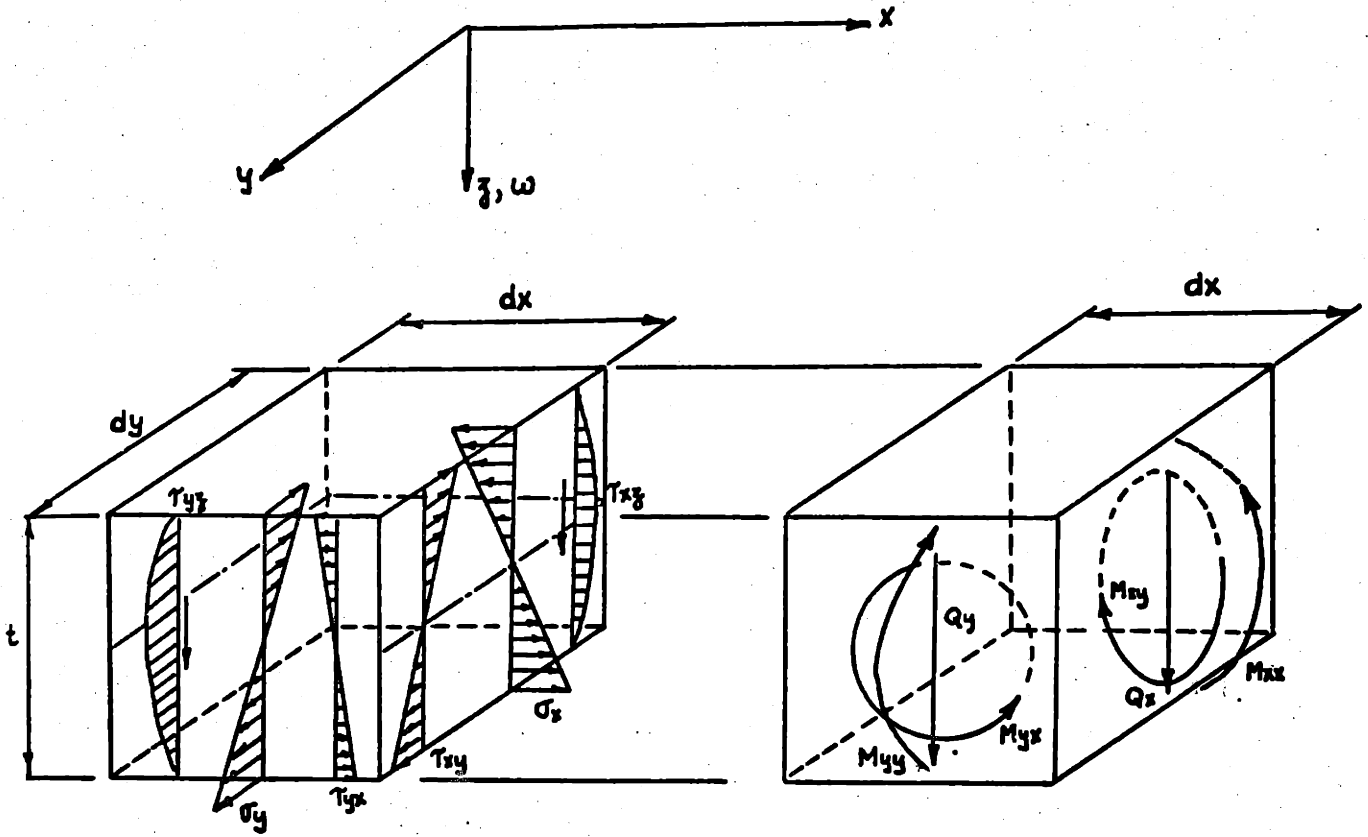

FIGURE 3
POSITIVE DIRECTION FOR
MOMENTS, SHEARS, & DISPLACEMENTS

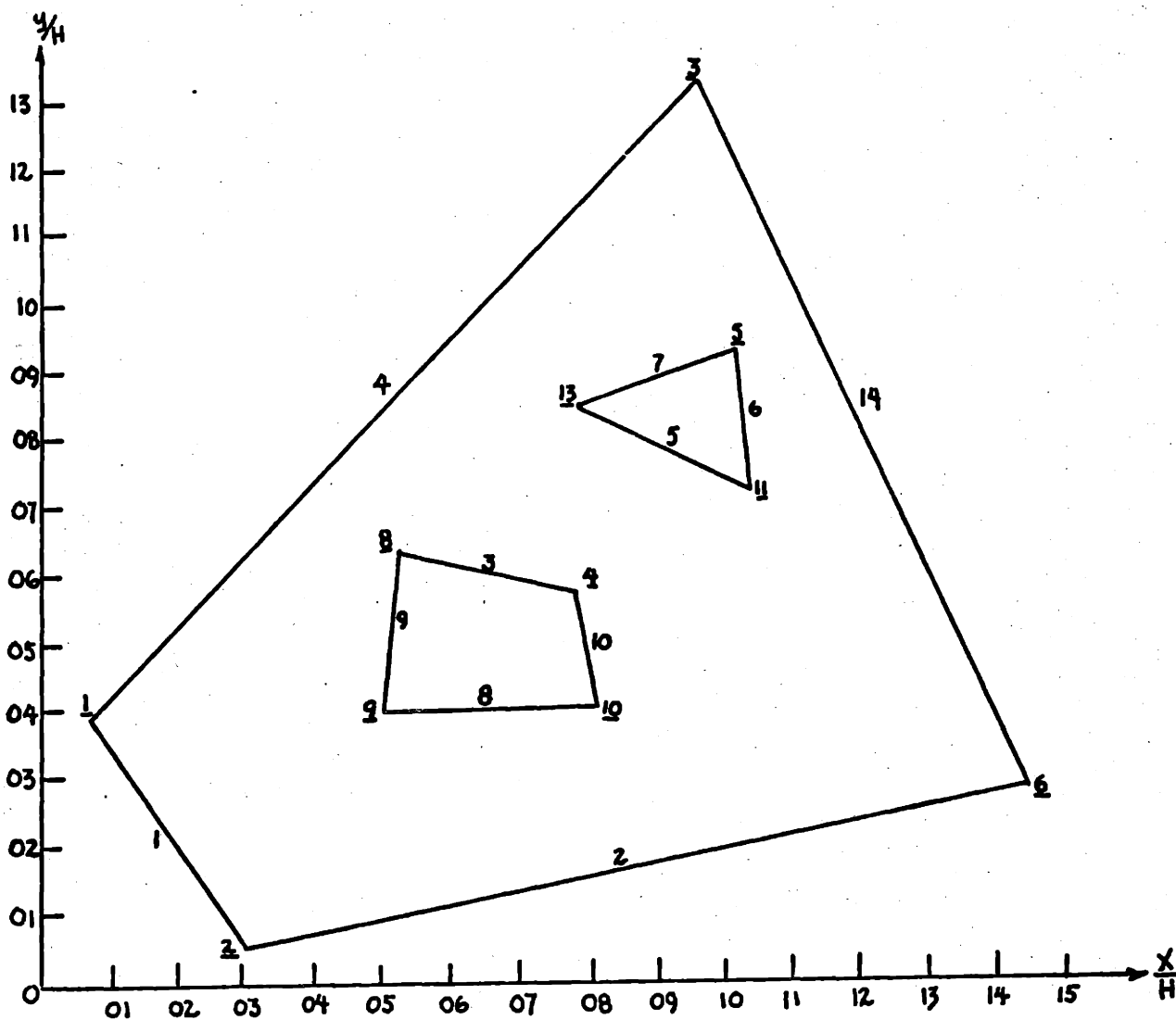

FIGURE 4
EXAMPLE PLATE TO
EXPLAIN INPUT -
SUPERPLATE

col 2

PLATE ANALYSIS

FIGURE (5a)

NAME OF DECK CARD

col 1

EXAMPLE THESIS PROBLEM, SUPERPLATE

FIGURE (5b)

TITLE CARD

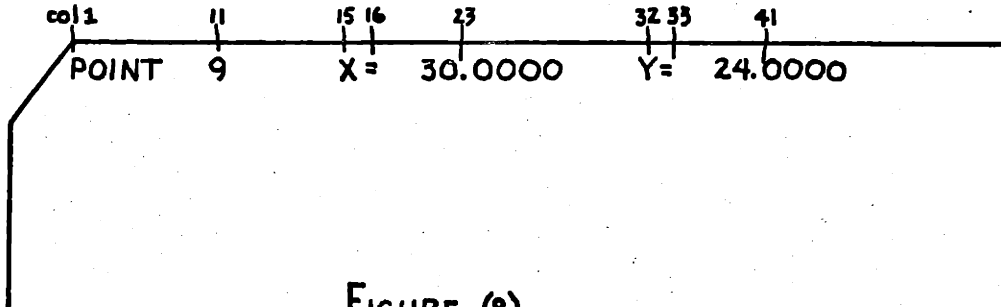

FIGURE (8)
CORNER POINT DATA CARD

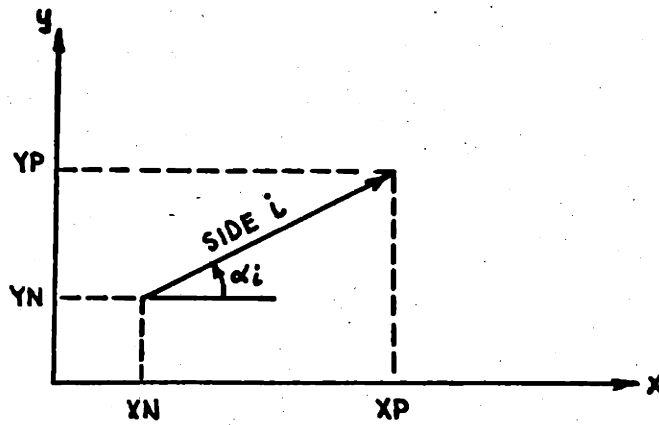

FIGURE (9)
SKETCH DEFINING α_i , XN ,
 YN , XP , & YP

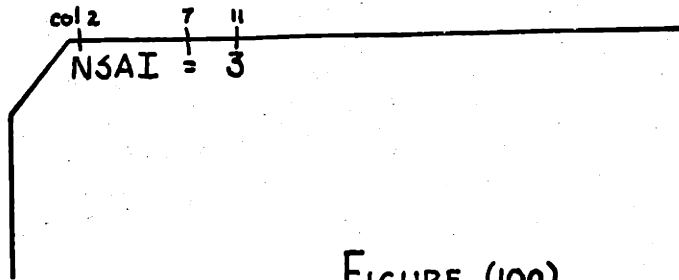

FIGURE (10a)
INITIAL CARD FOR BOUNDARY CONDITION INPUT

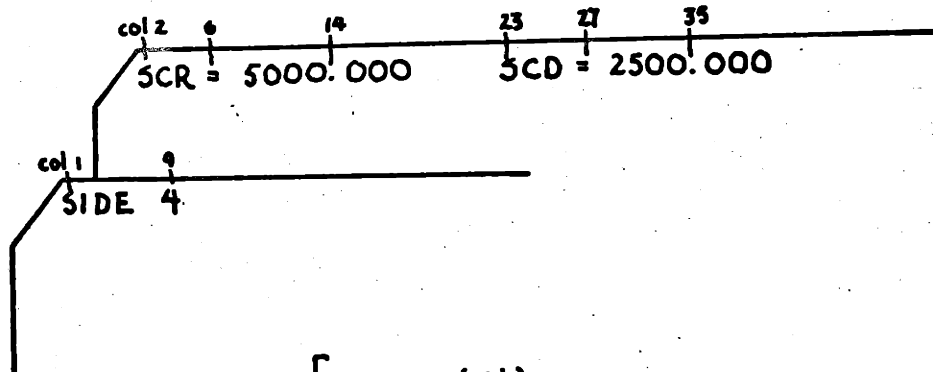

FIGURE (10b)
SEQUENCE OF CARDS FOR ELASTICALLY RESTRAINED EDGE

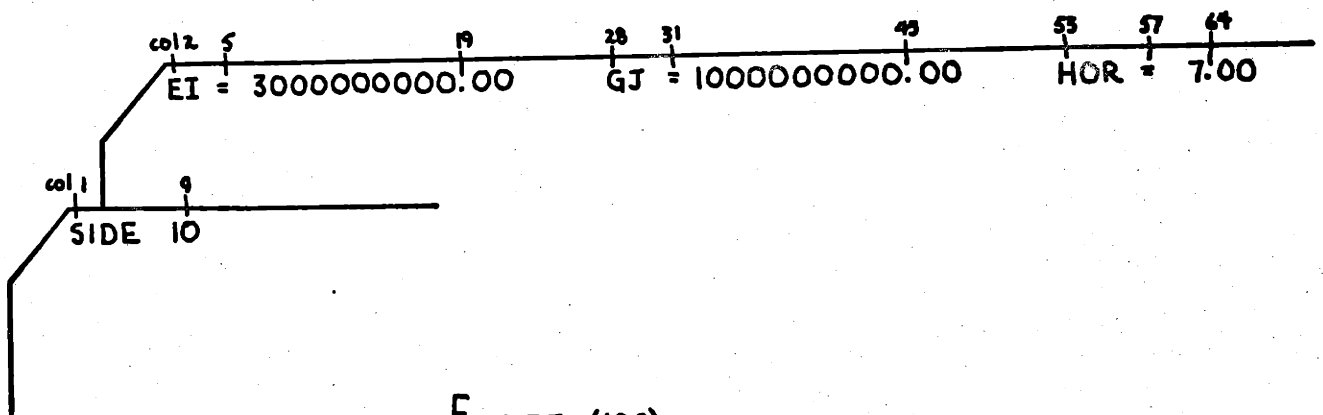

FIGURE (10c)
SEQUENCE OF CARDS FOR EDGE OF PLATE
CONNECTED TO FREE EDGEBEAM

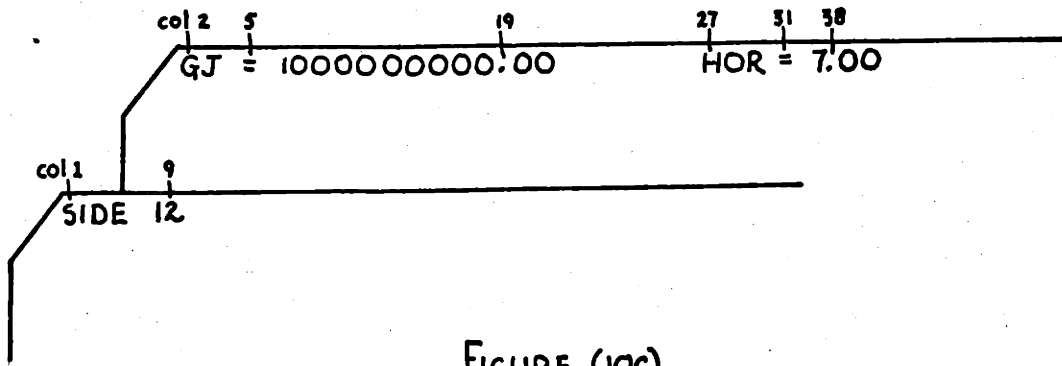

FIGURE (10c)
SEQUENCE OF CARDS FOR EDGE OF PLATE
CONNECTED TO SIMPLY SUPPORTED EDGEBEAM

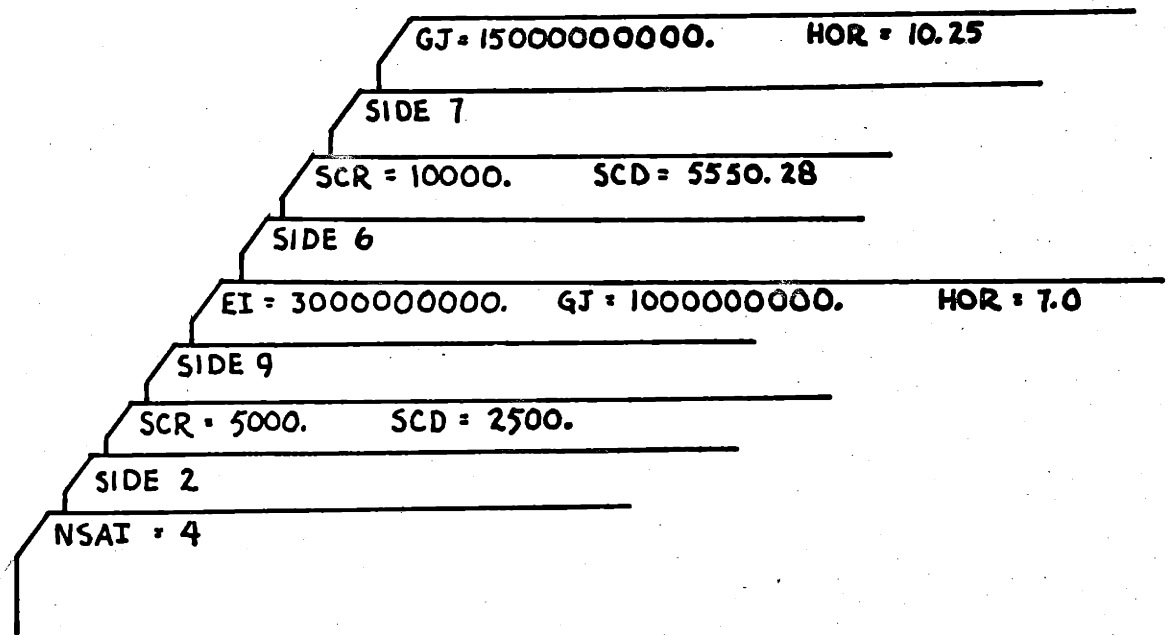

FIGURE (10d)
SEQUENCE OF ADDITIONAL INFORMATION
CARDS FOR SUPERPLATE

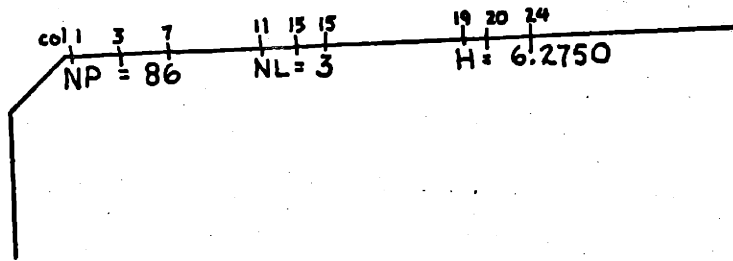

FIGURE (11a)
FIRST INTERNAL GRIDPOINT CARD

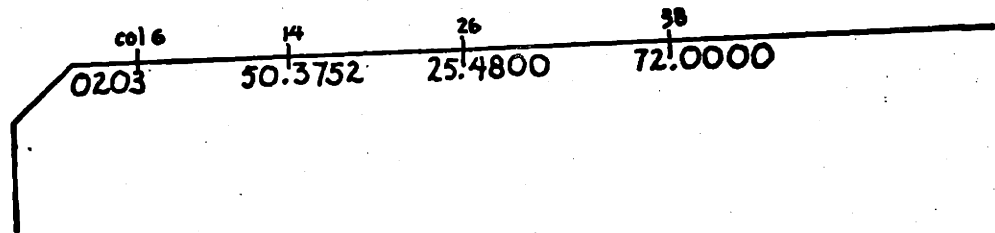

FIGURE (11b)
TYPICAL GRIDPOINT CARD
(ONE FOR EACH GRIDPOINT)

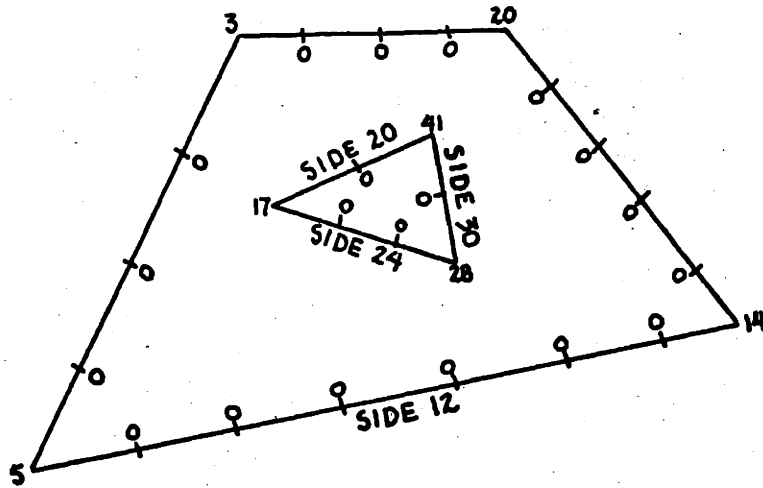

FIGURE (12)
NUMBERING OF BOUNDARY
POINTS AS GENERATED BY COMPUTER

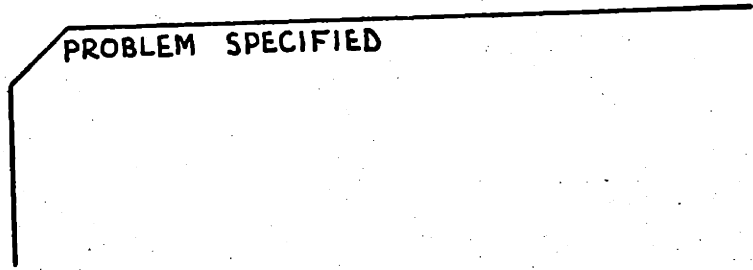
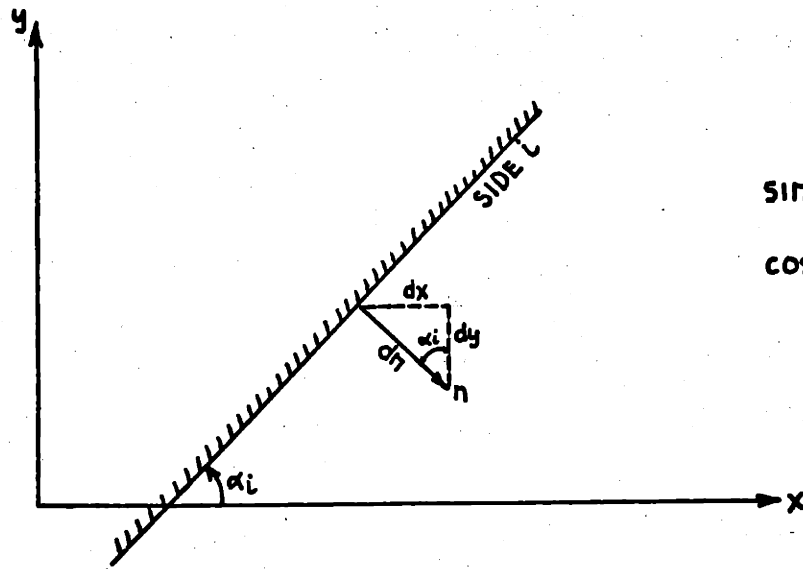

FIGURE (13)
PROBLEM SPECIFIED CARD



$$\sin \alpha_i = \frac{dy}{ds}$$

$$\cos \alpha_i = -\frac{dx}{ds}$$

FIGURE (14a)
ORIENTATION OF SIDE i AS
DEFINED BY NORMAL DERIVATIVE

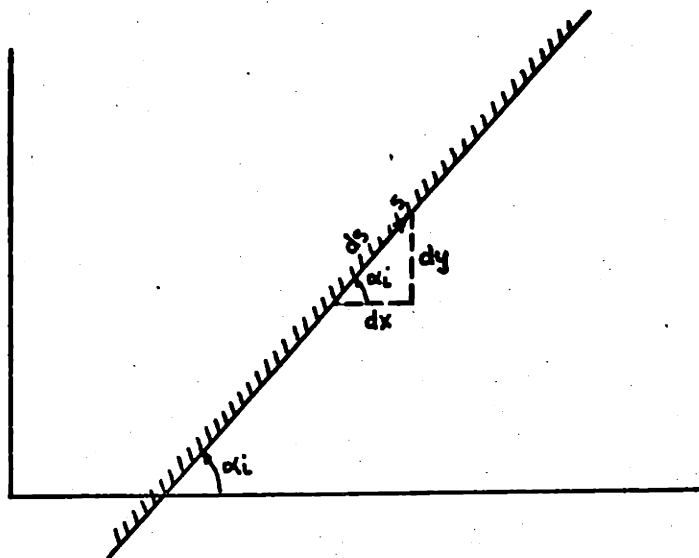

$$\sin \alpha_i = \frac{dx}{ds}$$

$$\cos \alpha_i = \frac{dy}{ds}$$

FIGURE (14b)
ORIENTATION OF SIDE i AS
DEFINED BY TANGENT DERIVATIVE

SCD

SCR

∞

∞

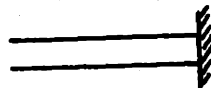

∞

0



0

∞

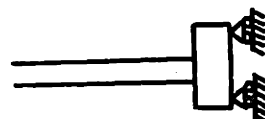

0

0

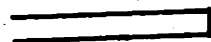

finite

0

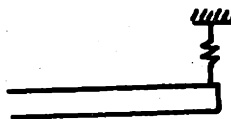

finite

∞

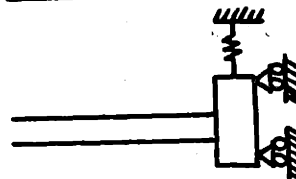

0

finite

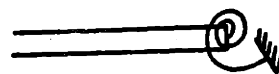

∞

finite

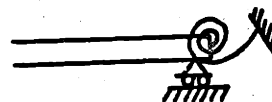

finite

finite

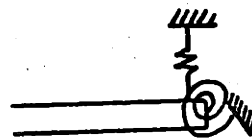

FIGURE (15)
LIMITING VALUES OF SPRING CONSTANTS

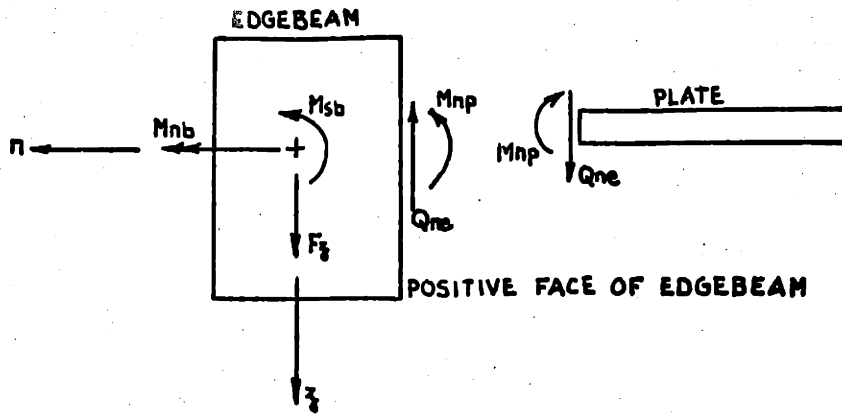

FIGURE (16a)
ASSUMED DIRECTIONS OF STRESS RESULTANTS
AND COUPLES ACTING ON POSITIVE FACE OF
FREE EDGEBEAM

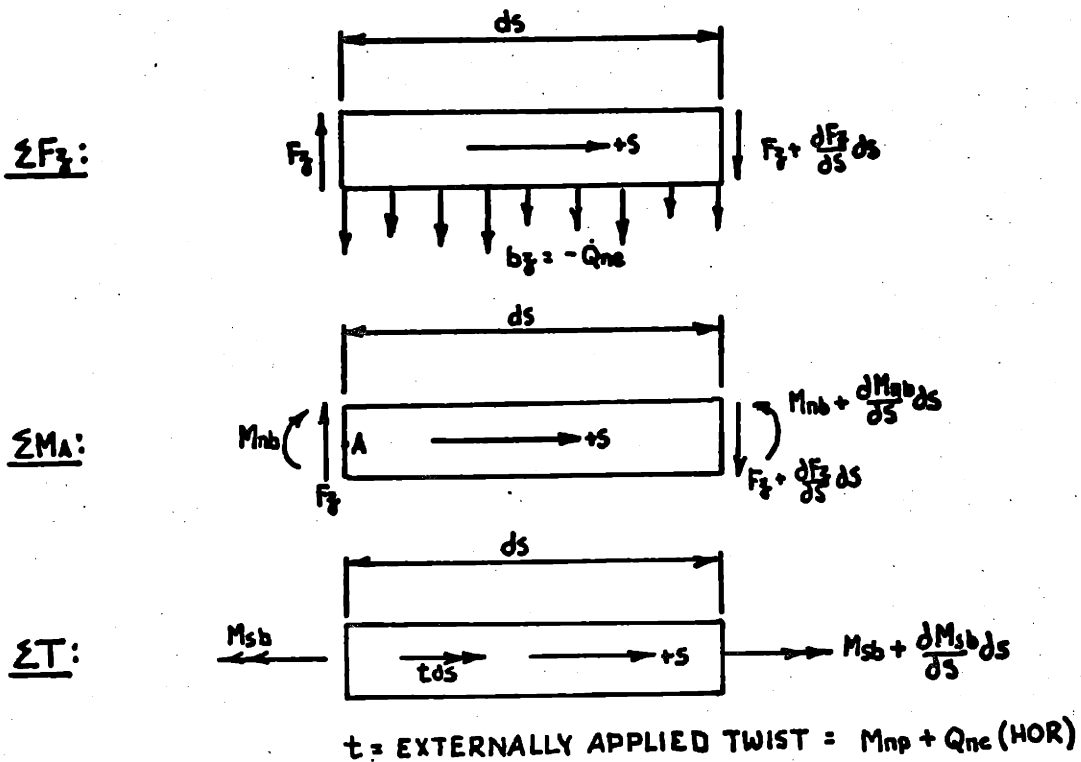

FIGURE (16b)
ORIENTATION OF FORCES AND COUPLES USED
IN FREE EDGEBEAM EQUILIBRIUM EQUATIONS

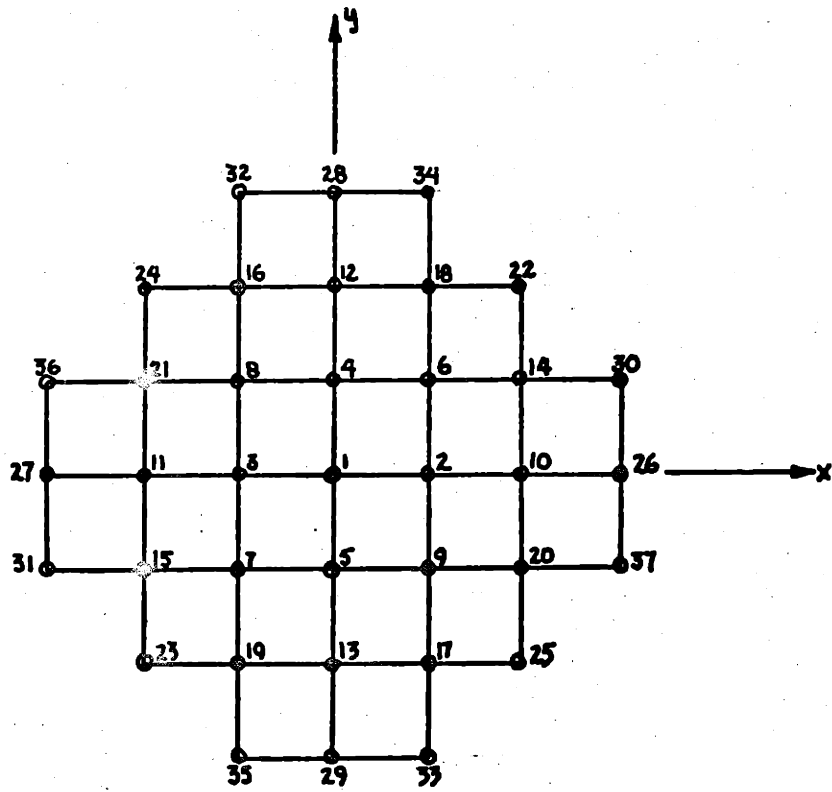

FIGURE (17)
RELATIVE NUMBERING OF GRIDPOINTS
(CENTRAL POINT = 1)

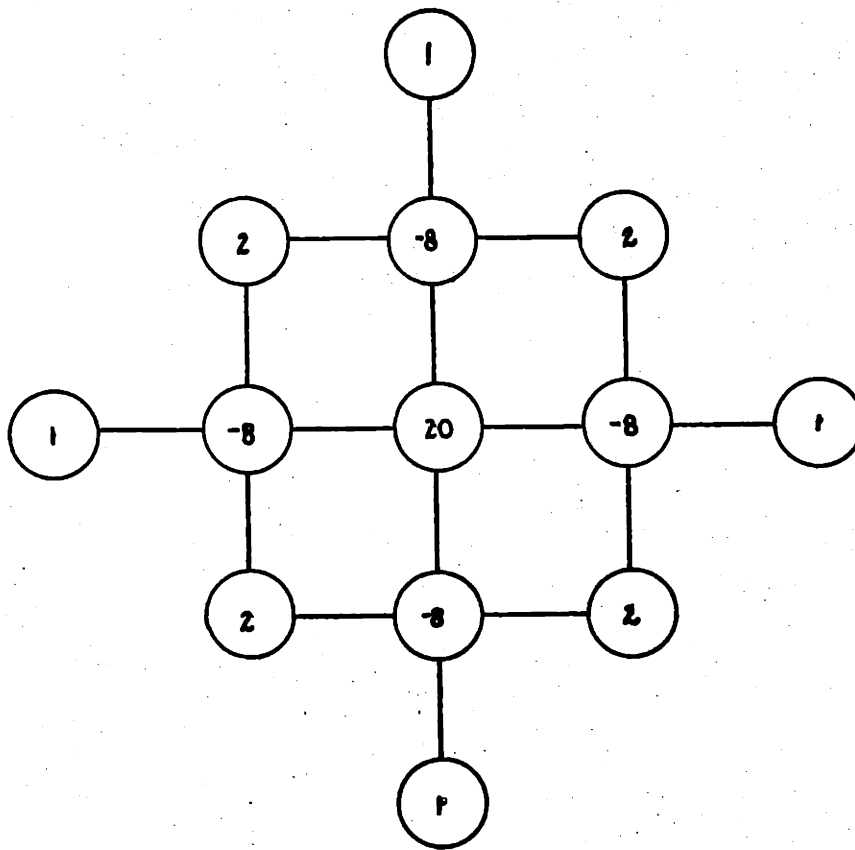

FIGURE (18a)
STANDARD MOLECULE FOR $\nabla^4 w$

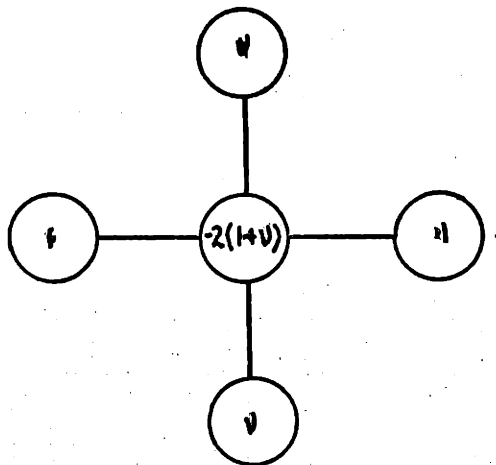

FIGURE (18b)
STANDARD MOLECULE FOR M_{xx}/D_p

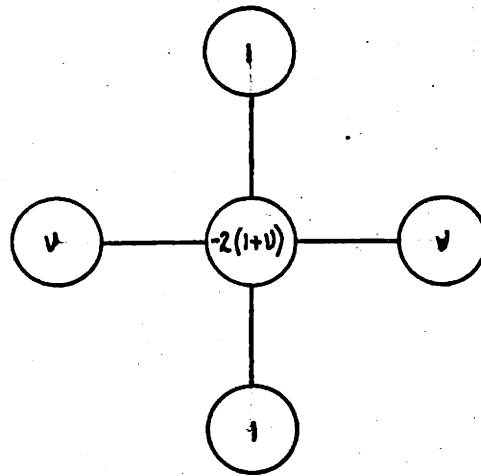

FIGURE (18c)
STANDARD MOLECULE FOR M_{1+V}/DP

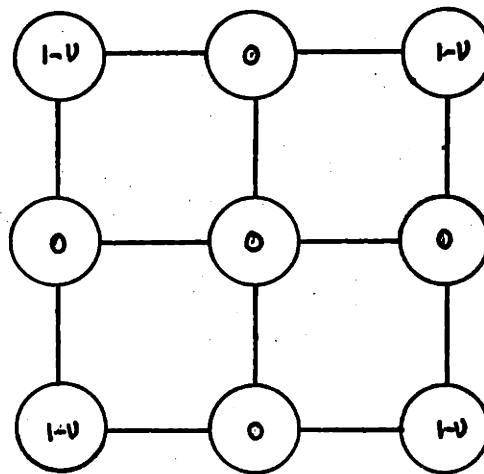

FIGURE (18d)
STANDARD MOLECULE FOR M_{1+V}/DP

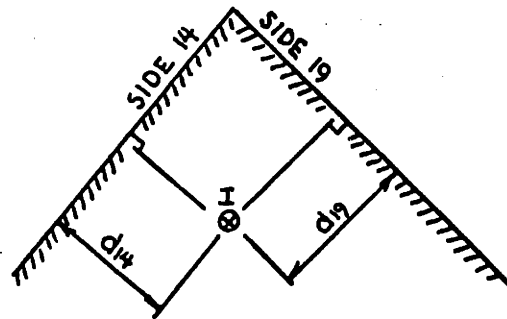

FIGURE (19a)
DISTANCE FROM CENTRAL GRIDPOINT
TO EACH SIDE - d_j

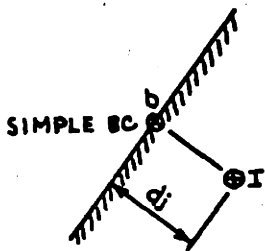

FIGURE (19b)
BOUNDARY CONDITIONS - $\sqrt{2}H < d_i < 2H$

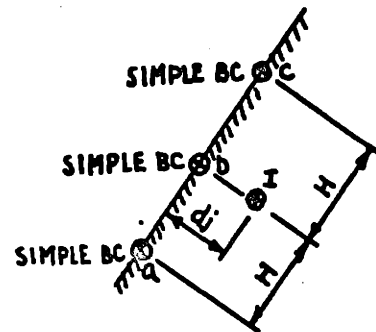

FIGURE (19c)
BOUNDARY CONDITIONS - $H < d_i < \sqrt{2}H$

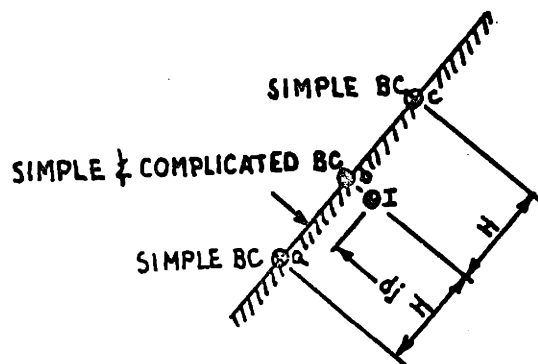

FIGURE (19d)
BOUNDARY CONDITIONS - $d_i < H$

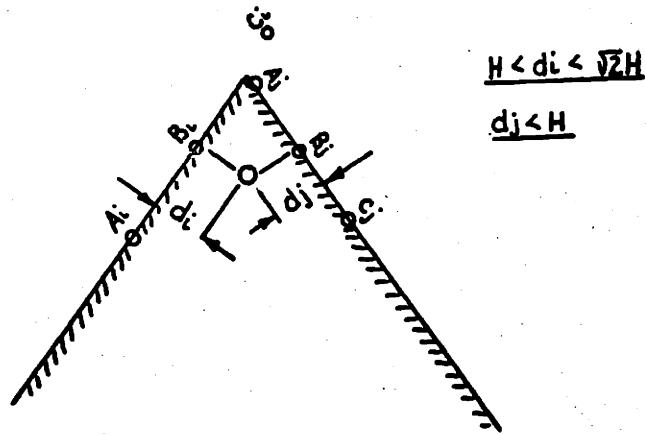

FIGURE (20)
EXAMPLE OF CASE WHERE SOME
BOUNDARY POINTS DO NOT FALL ON
THE SIDE OF THE PLATE

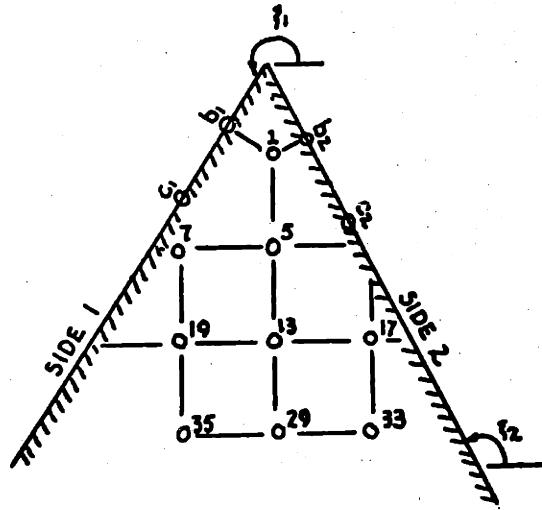

FIGURE (21)
EXAMPLE PROBLEM USED IN ILLUSTRATING
METHOD OF FORMULATING MOLECULE
FOR GRIDPOINT NEAR BOUNDARY

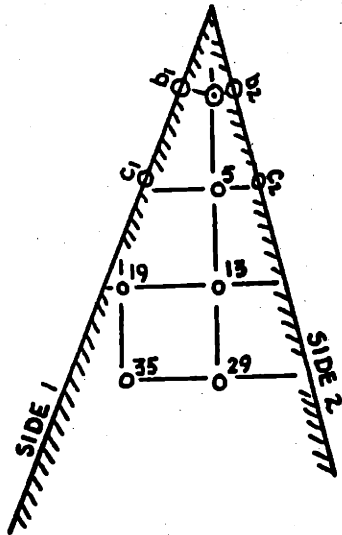

FIGURE (22)

EXAMPLE OF MOLECULE IN WHICH
ACCURACY WILL NOT BE UP TO SIXTH
DERIVATIVE OF SERIES EXPANSION

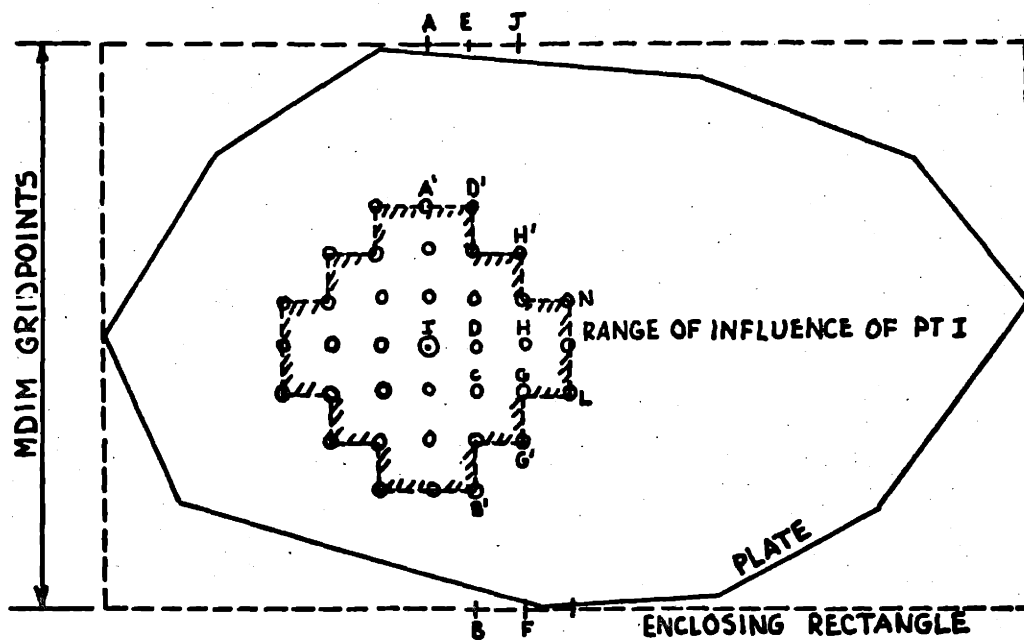

FIGURE (24)
PLATE ILLUSTRATING BAND
MATRIX CHARACTERISTICS
OF FINITE DIFFERENCE EQUATIONS

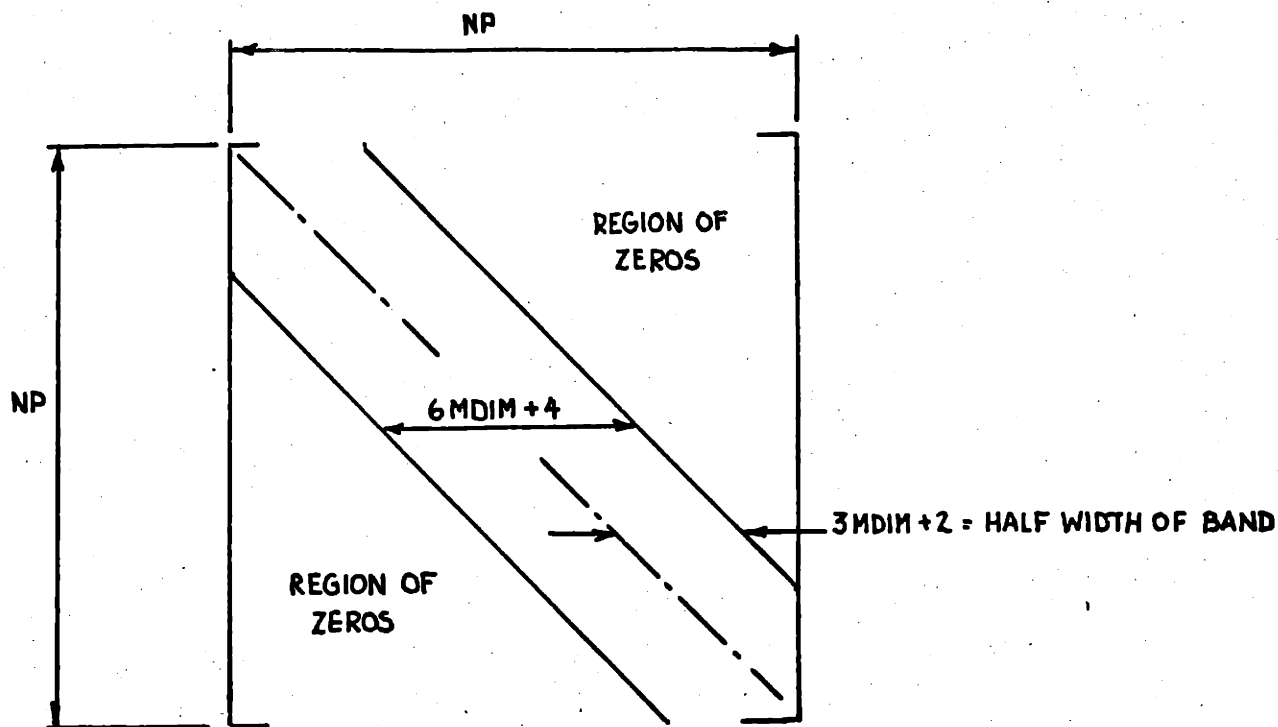

FIGURE (25)
COEFFICIENT MATRIX, C , IN
FINAL SET OF SIMULTANEOUS
DIFFERENCE EQUATIONS:

$$\underline{[C]} \{w\} = \{q\}$$

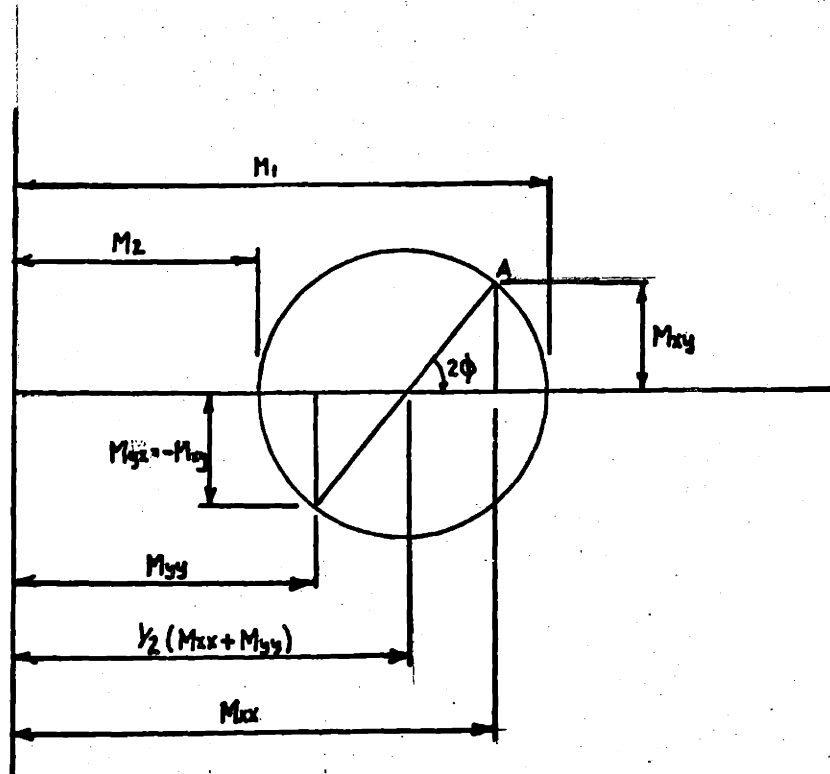

FIGURE (26a)
POSITIVE MOMENTS -
MOHR CIRCLE REPRESENTATION

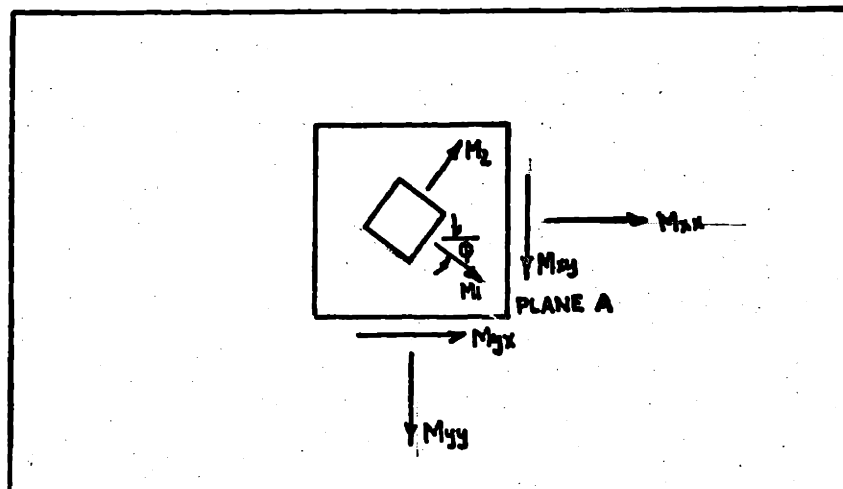
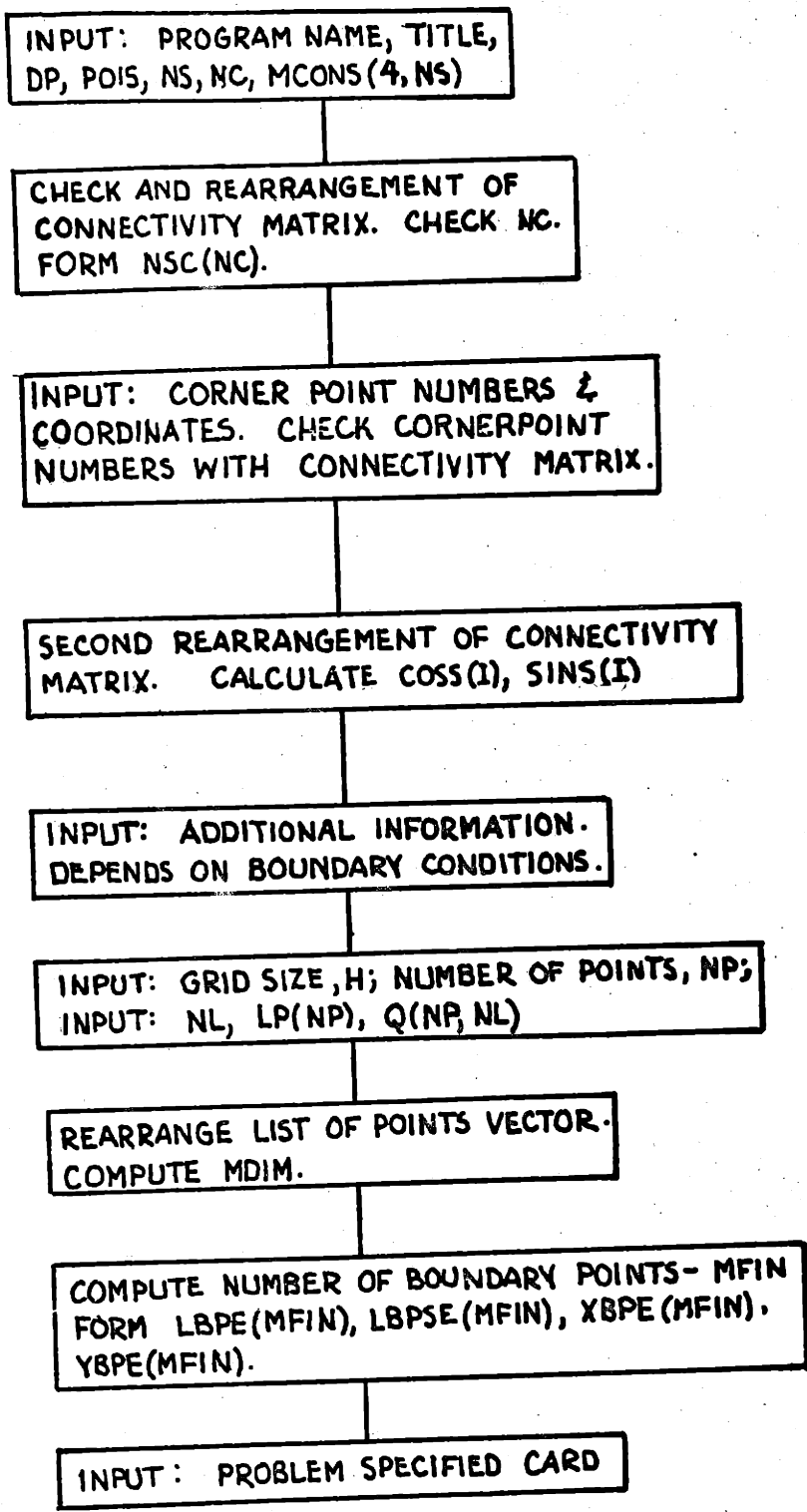
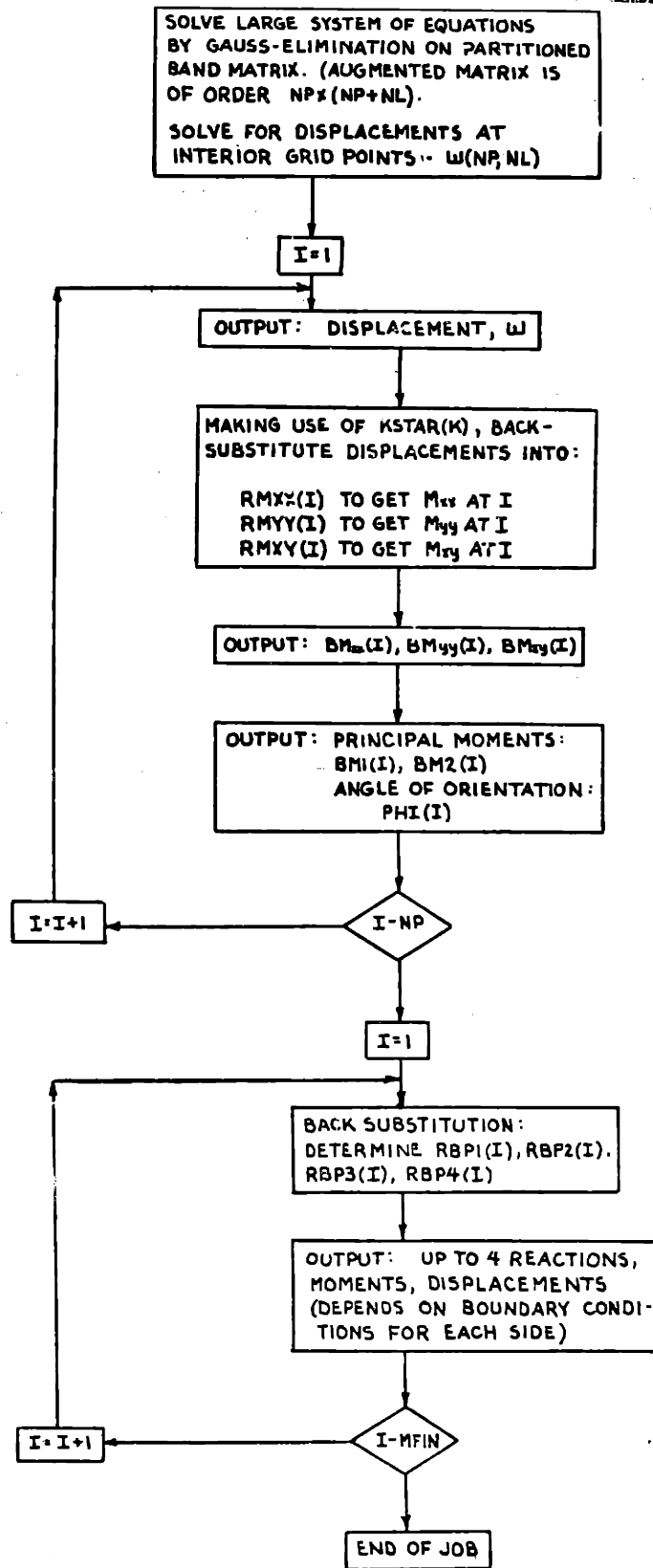

FIGURE (26b)
POSITIVE MOMENTS
VECTOR REPRESENTATION



LINK 1
INPUT, SORTING, PRELIMINARY CALCULATIONS

FIGURE 27-1



LINK 4
SOLUTION, BACK-SUBSTITUTION
AND OUTPUT

VII BIBLIOGRAPHY AND REFERENCES

1. M. Engeli: "Automatisierte Behandlung elliptischer Randwertprobleme", ETH Thesis, (1962).
2. L. Collatz. "Numerical Treatment of Differential Equation", Springer-Verlag, Berlin (1959)
3. S. Timoshenko and S. Woinowky-Krieger:
"Theory of Plates and Shells" McGraw-Hill,
New York (1959)
4. Wolf, John: "Automatic Assemblage of Pucher's Equation",
MIT M.S. Thesis (1965)
5. S. Crandall: "Engineering Analysis" McGraw-Hill, New York,
(1956)
6. V. R. Zurmühl: "Behandlung der Plattenaufgabe nach dem
verbesserten Differenzverfahren", Zeitschrift
Für Angewandte Mathematik und Mechanik, Band
37, Heft 1/2, January, February, 1957.

VIII

APPENDICES

A. Definitions of Symbols

- AC(I) = Total area enclosed by contour I.
- A_1 = Value of molecule at point 1 for a gridpoint.
- AN = Area enclosed by one side of a contour and the x axis.
- A_w = Augmented matrix of order 21×34 used when solving for gridpoint molecules.
- C = Coefficient matrix to be inverted when obtaining gridpoint molecules.
- COSS(I) = Cosine of angle between positive direction of side I and the positive x axis.
- CPC = Corner point coordinates (in.).
- d_1 = Perpendicular distance from the gridpoint to side 1.
- DP = Flexural rigidity of plate ($lb \cdot in^2/in$).
- EI_n = Flexural rigidity of edgebeam about n axis ($lb \cdot in^2$).
- F_z = Transverse shear force on positive face of edgebeam (lb).
- GJ = Torsional rigidity of edgebeam ($lb \cdot in^2$).
- H = Gridpoint spacing (in).
- HOR = Horizontal distance from shear center of edgebeam to function of plate and beam (inches).
- LBPE = List of boundary points (at which reaction, moment, and/or displacement will be computed.)
- LBPSE = List of sides on which each boundary point in LBPE is located.

- LP = List of gridpoints.
- LPRA = Absolute number of gridpoint as obtained from relative number of central gridpoint.
- MC = List of cornerpoint numbers
- MCONS = Connectivity matrix of plate; contains each side, its initial and terminal cornerpoint, and its boundary condition.
- MDIM = Maximum number of points spaced a distance H apart that can be placed along the shortest side of the rectangle enclosing the plate.
- M_{nb} = Bending moment acting on positive face of edgebeam.
- M_{np} = Bending moment of plate at junction of plate and edgebeam.
- M_{sb} = Twisting moment acting on positive face of edgebeam.
- M_{xx}, M_{yy} = Bending moment acting on the side of a plate element that is perpendicular to the x, y axis respectively.
- M_{xy} = Twisting moment acting on above plate element.
- M_1, M_2 = Principal moments acting on plate element.
- NC = Total number of contours in plate.
- NL = Total number of loading conditions to be considered by the analysis (up to 3)
- NP = Total number of gridpoints on the plate (up to 1000).
- NS = Total number of sides of the plate (up to 100)

- NSAI = Number of sides for which additional information about boundary conditions is to be read in.
- NSC(1) = Number of sides in contour 1.
- POIS, U = Poissons ratio of plate.
- Q_n, Q_{ne} = Transverse shear stress resultant of plate.
- q_r = Distributed force per unit area acting on grid-point r. (lb/in²).
- SCD = Translational spring constant (lb/in/in).
- SCR = Rotational spring constant (lb-in/in).
- SINS(1) = Sine of angle between positive direction of side 1 and positive x axis.
- t = Thickness of plate (inches).
- w = Vertical displacement of plate.
- XBPE, YBPE = Cartesian Coordinates of points along boundary at which reactions, moments, and/or displacements will be computed.
- XN, YN = Cartesian coordinates of negative cornerpoint of a side of the plate.
- XP, YP = Cartesian coordinates of positive cornerpoint of a side of the plate.
- α_i = Angle of inclination at negative end of side 1 between side 1 and positive x axis.
- ϕ = Angle that principal moment M_1 makes with positive x axis.
- σ_i = Stress^{at} point in plate in the i direction.
- τ = Angle of twist of positive face of edgebeam

B. List of Figures

<u>FIGURE</u>		<u>PAGE</u>
1.	Example Problem Illustrating Inaccuracies of Standard Difference Method	69
2.	Assumed Positive Directions for Plate Contours	70
3.	Positive Directions for Moments, Shears, and Displacements	71
4.	Example Plate to Explain Input-Superplate	72
5.	Name of Deck Card and Title Card	73
6.	Plate Constant	74
7.	Data Card for Connectivity Matrix	74
8.	Corner Point Data Card	75
9.	Sketch Defining XN, YN, XP, YP	75
10.	Boundary Condition Data Cards	76
11.	Gridpoint Data Cards	78
12.	Numbering of Boundary Points as Generated by Computer	79
13.	Problem Specified Card	80
14.	Orientation of Side 1 as Defined by Normal Derivative and by Tangent Derivative	81
15.	Limiting Values of Spring Constants	82
16.	Stress Resultants and Forces Acting on Edgebeam.	83
17.	Relative Numbering of Gridpoints	84
18.	Standard Molecules for M_{xx} , M_{yy} and M_{xy}	85

	PAGE
19. Criteria Used in Accounting for Boundary Conditions	87
20. Example of Case where Some Boundary Points do not Fall on the Side of the Plate	88
21. Example Problem Used in Illustrating Method of Formulating Molecule for Gridpoint Near Boundary	89
22. Example of Molecule in which Accuracy will not be up to Sixth Derivative of Series Expansion	90
23. Example Problem to Illustrate Computation of Boundary Quantities	91
24. Plate Illustrating Band Matrix Characteristics of Finite Difference Equations	92
25. Coefficient Matrix in Final Set of Simultaneous Difference Equations	93
26. Positive Moments - Mohr Circle and Vector Representation	94

	<u>Page</u>
27. <u>Flow Charts</u>	
1. Input, Sorting Preliminary Calculations	94a
2. Automatic Assemblage of Difference Equations	94b
3. Difference Equations for Boundary Points	94c
4. Solution, Back-Substitution, and Output	94d

C. List of Tables

<u>TABLE</u>	<u>PAGE</u>
1. Boundary Condition Input	10
2. Internal Storage of Boundary Conditions	10
3. Formation of Connectivity Matrix for Superplate	11
4. Internal Storage of Corner Point Data for Superplate	13
5. Initial and Final Rearrangements of Connectivity Matrix	16
6. Absolute Coordinates of Points Relative to Central Gridpoint	36

0
1
2
3
4
5

IX
SOURCE PROGRAMS
FOR
PLATE ANALYSIS

LINK1.....INPUT, SORTING, AND PRELIMINARY CALCULATIONS.

```
DIMENSION TITLE(12)
DIMENSION MCONS(4,100)
DIMENSION MC(100)
DIMENSION CPC(100,2)
DIMENSION LBPE(1000)
DIMENSION LBPSF(1000)
DIMENSION XBPE(1000)
DIMENSION YBPE(1000)
DIMENSION COSS(100)
DIMENSION SINS(100)
DIMENSION LP(1000)
DIMENSION LPC(1000)
DIMENSION Q(1000,3)
COMMON TITLE,MCONS,MC,CPC,LBPE,LBPSE,XBPE,YBPE,COSS,SINS,LP,LPC,
1Q,INTSW,IFXQ,INEXT,NS,NC,NP,NL,MDIM,H,MFIN
DIMENSION AREA(33)
DIMENSION NSC(33)
DIMENSION SCR(100)
DIMENSION SCD(100)
DIMENSION EI(100)
DIMENSION GJ(100)
DIMENSION HOR(100)
DIMENSION JSIDE(100)
EXTERNAL LIST,LIST1
INEXT=1
800 GO TO (901,1001),INEXT
C INPUT OF PROGRAM NAME AND TITLE OF PROBLEM.
901 I=MATCH(LIST,K,1)
IF(I-5) 901,902,901
902 IF(K-3) 1001,1001,901
1001 IEXQ=0
INEXT=1
IERR=0
READ 35,(TITLE(I),I=1,12)
35 FORMAT (12A6)
PRINT 36
36 FORMAT(1H1,15X,12HPROBLEM NAME//)
PRINT 37,(TITLE(I),I=1,12)
37 FORMAT (20X,12A6//)
C INPUT OF PLATE DATA.
1002 READ 1, DP,POIS,NS,NC
1 FORMAT (6H DP = F15.2,3X,7HPOIS = F5.3,3X,5HNS = I4,3X,5HNC = I4)
1003 PRINT 1, DP,POIS,NS,NC
C USE SUBROUTINE MATCH TO READ IN MCONS(I,J), AND TO CHANGE
C MCONS(4,J) FROM ALPHABETIC TO NUMERICAL DATA
DO 600 J=1,NS
I=MATCH(LIST1,K,1)
IF(I-5) 401,601,401
601 IF(K-7) 402,602,402
602 DO 603 L=1,3
I=MATCH(LIST1,K,2)
603 MCONS(L,J)=K
I=MATCH(LIST1,K,0)
```

```
IF(K-3) 606,605,606
605 I=MATCH(LIST1,K,0)
GO TO (607,401,401,401,608,401),I
607 K=3
GO TO 606
608 IF(K-5) 401,606,401
606 MCONS(4,J)=K
GO TO 600
401 PRINT 63, J
63 FORMAT(25H SIDE DATA ON CARD NUMBER, 15 , 19HIS IN WRONG FORMAT.)
STOP
402 PRINT 64
64 FORMAT(62H CARDS FOR SIDE DATA ARRANGED IMPROPERLY. EXECUTION DE
1LETED.)
STOP
600 CONTINUE
PRINT 56
56 FORMAT(///15X,19HCONNECTIVITY MATRIX//)
IF(NS-15) 1005,1005,1006
1005 PRINT 1009, (MCONS(1,I), I=1,NS)
1009 FORMAT(/11X,11H SIDE NUMBER,8X,15I6)
PRINT 1007, (MCONS(2,I), I=1,NS)
1007 FORMAT(/75X,25H FROM CORNER POINT NUMBER 15I6)
PRINT 1008, (MCONS(3,I), I=1,NS)
1008 FORMAT(/6X,22H TO CORNER POINT NUMBER,2X,15I6)
PRINT 2001, (MCONS(4,I), I=1,NS)
2001 FORMAT(/7X,18H BOUNDARY CONDITION,5X,15I6)
PRINT 21
21 FORMAT (1X,////)
GO TO 1011
1006 PRINT 1012
1012 FORMAT(10X,11H SIDE NUMBER,15X,19H CORNER POINT NUMBER,15X,
18H BOUNDARY)
PRINT 2002
2002 FORMAT(36X,4H FROM,13X,2H TO,15X,9H CONDITION//)
DO 1013 I=1,NS
1013 PRINT 1014, (MCONS(J,I), J=1,4)
1014 FORMAT(16X,I3,13X,I3,18X,I3//)
C FIRST REARRANGMENT OF CONNECTIVITY MATRIX
1011 NCCHEC=0
NSIDEC=1
DO 1010 JSORT=1,NS
IF(JSORT-NS) 1020,1031,1020
1020 ISERCH=JSORT+1
DO 1030 ISORT=ISERCH,NS
IF(MCONS(3,JSORT)-MCONS(2,ISORT)) 1035,1040,1035
1035 IF(MCONS(3,JSORT)-MCONS(3,ISORT)) 1030,1036,1030
1030 CONTINUE
1031 NCCHEC=NCCHEC+1
NSC(NCCHEC)=NSIDEC
IF(NSIDEC-2) 1900,1900,1050
1050 NSIDEC=1
GO TO 1010
1036 ITEMP=MCONS(2,ISORT)
MCONS(2,ISORT)=MCONS(3,ISORT)
MCONS(3,ISORT)=ITEMP
1040 DO 1060 ISWICH=1,4
```



```
ITEMP=MCONS(ISWICH,ISERCH)
MCONS(ISWICH,ISERCH)=MCONS(ISWICH,ISORT)
1060 MCONS(ISWICH,ISORT)=ITEMP
NSIDEC=NSIDEC+1
1010 CONTINUE
DO 1802 I=1,NC
1802 PRINT 31, I,NSC(I)
31 FORMAT(/9H CONTOUR I4,3X,17H NUMBER OF SIDES=I4)
IF(NCCHEC-NC) 1910,1070,1910
1070 DO 1100 ITWICE=1,3
DO 1101 JTWICE=1,NS
DO 1102 KTWICE=1,NS
IF(KTWICE-JTWICE) 1110,1102,1110
1110 IF(MCONS(ITWICE,JTWICE)-MCONS(ITWICE,KTWICE)) 1102,1115,1102
1115 IF(ITWICE-1) 1940,1930,1940
1102 CONTINUE
1101 CONTINUE
1100 CONTINUE
LCLOSE=0
KCLOSE=1
DO 1120 JCLOSE=1,NC
LCLOSE=NSC(JCLOSE)+LCLOSE
IF(MCONS(3,LCLOSE)-MCONS(2,KCLOSE)) 1950,1120,1950
1120 KCLOSE=LCLOSE+1
DO 1130 ICPRED=1,NS
C INPUT OF CORNER POINT NUMBERS AND COORDINATES
1140 READ 4,MC(ICPRED),(CPC(ICPRED,JCPRED),JCPRED=1,2)
4 FORMAT(6HPOINT I6,3X,2HX=F12.4,3X,2HY=F12.4)
JMCHEK=0
DO 1150 IMCHEK=1,NS
IF(MC(ICPRED)-MCONS(3,IMCHEK)) 1150,1160,1150
1160 JMCHEK=1
1150 CONTINUE
IF(JMCHEK) 1960,1960,1130
1130 CONTINUE
PRINT 57,NS
57 FORMAT(////15X,21HLIST OF CORNER POINTS,//5X,23HNUMBER OF CORNER P
POINTS,I4/)
PRINT 59
59 FORMAT(10X,12HCORNER POINT,13X,1HX,18X,1HY,18X,/13X,6HNUMBER,11X,
111HCOORDINATES,8X,11HCOORDINATES///)
PRINT 58,(MC(I),(CPC(I,J),J=1,2),I=1,NS)
58 FORMAT(14X,I3,10X,F12.4,7X,F12.4//)
C FINAL REARRANGEMENT OF CONNECTIVITY MATRIX
AMAX=0.0
JAREA2=0
DO 1170 IAREA=1,NC
AREA(IAREA)=0.0
JAREA=NSC(IAREA)
DO 1185 KAREA=1,JARFA
JAREA2=JAREA2+1
DO 1181 IFIND=1,NS
IF(MC(IFIND)-MCONS(3,JAREA2)) 1182,1183,1182
1183 MAREA=IFIND
1182 IF(MC(IFIND)-MCONS(2,JARFA2)) 1181,1184,1181
1184 NAREA=IFIND
1181 CONTINUE
```

```
1185 AREA(IAREA)=AREA(IAREA)+(CPC(MAREA,1)-CPC(NAREA,1))*(CPC(MAREA,2)+
1CPC(NAREA,2))/2.0
IF(ABS (AREA(IAREA))-AMAX) 1170,1170,1190
1190 IMAX=IAREA
AMAX=ABS (AREA(IAREA))
1170 CONTINUE
IF(IMAX-1) 1180,1180,1195
1195 ISUM=0
JSUM=NSC(IMAX)
DO 1200 I=1,IMAX
1200 ISUM=ISUM+NSC(I)
LSUM=ISUM-1
DO 1210 I=1,4
DO 1220 J=1,JSUM
ITEMP=MCONS(I,ISUM)
DO 1230 K=1,LSUM
KSUM=ISUM-K
1230 MCONS(I,KSUM+1)=MCONS(I,KSUM)
1220 MCONS(I,1)=ITEMP
1210 CONTINUE
ISUM=IMAX-1
DO 1250 I=1,ISUM
LSUM=IMAX-I
1250 NSC(LSUM+1)=NSC(LSUM)
NSC(1)=JSUM
1180 DO 1260 IFINAL=1,NC
IF(IFINAL-1) 1270,1280,1270
1280 IF(AREA(1)) 1260,1260,1290
1270 IF(AREA(IFINAL)) 1290,1290,1260
1290 JFINAL=NSC(IFINAL)
IFTOT=0
DO 1300 KFINAL=1,IFINAL
1300 IFTOT=IFTOT+NSC(KFINAL)
MFINAL=IFTOT-NSC(IFINAL)+1
JBEEP=MFINAL
KBEEP=IFTOT
1310 ITEMP=MCONS(1,JBEEP)
JTEMP=MCONS(4,JBEEP)
MCONS(1,JBEEP)=MCONS(1,KBEEP)
MCONS(4,JBEEP)=MCONS(4,KBEEP)
MCONS(1,KBEEP)=ITEMP
MCONS(4,KBEEP)=JTEMP
JBEEP=JBEEP+1
KBEEP=KBEEP-1
IF(KBEEP-JBEEP) 1320,1320,1310
1320 KBEEP=IFTOT
DO 1330 I=MFINAL,IFTOT
ITEMP=MCONS(3,KBEEP)
MCONS(3,KBEEP)=MCONS(2,I)
MCONS(2,I)=ITEMP
1330 KBEEP=KBEEP-1
1260 CONTINUE
DO 1350 IANGLE=1,NS
DO 1351 I=1,NS
IF(MC(I)-MCONS(3,IANGLE)) 1352,1353,1352
1352 IF(MC(I)-MCONS(2,IANGLE)) 1351,1354,1351
1353 JANGLE=I
```

```
GO TO 1351
1354 KANGLE=I
1351 CONTINUE
      COSS(IANGLE)=(CPC(JANGLE,1)-CPC(KANGLE,1))/(SQRT ((CPC(JANGLE,1)-C
      IPC(KANGLE,1))*2+(CPC(JANGLE,2)-CPC(KANGLE,2))*2))
1350 SINS(IANGLE)=(CPC(JANGLE,2)-CPC(KANGLE,2))/(SQRT ((CPC(JANGLE,1)-
      IPC(KANGLE,1))*2+(CPC(JANGLE,2)-CPC(KANGLE,2))*2))
C      ADDITIONAL INFORMATION
      READ 2020, NSAI
2020 FORMAT(8H NSAI = I3)
      PRINT 2020, NSAI
      DO 2050 I=1,NSAI
      READ 2021, JSIDE(I)
2021 FORMAT(6H SIDE ,I3)
      PRINT 2021, JSIDE(I)
      K=1
2022 IF(MCONS(1,K)-JSIDE(I)) 2023,2024,2023
2024 IF(MCONS(4,K)-4) 2028,2026,2025
2026 READ 2027, SCR(K), SCD(K)
2027 FORMAT(7H SCR = ,F10.3,5X,6HSCD = ,F10.3)
      PRINT 2027, SCR(K), SCD(K)
      GO TO 2050
2028 PRINT 2029, I
2029 FORMAT(37H ADDITIONAL INFORMATION DATA IN CARD ,I3,13HIS INCORRECT
      1.,3X,18HEXECUTION DELETED.)
      CALL CHNXIT
2025 IF(MCONS(4,K)-5) 2031,2031,2033
2031 READ 2032, EI(K),GJ(K),HOR(K)
2032 FORMAT(6H EI = F15.2,5X,6H GJ = F15.2,5X,6HHOR = F8.2)
      PRINT 2032, EI(K),GJ(K),HOR(K)
      GO TO 2050
2033 READ 2034, GJ(K), HOR(K)
2034 FORMAT(6H GJ = F15.2,5X,6HHOR = F8.2)
      PRINT 2034, GJ(K), HOR(K)
      GO TO 2050
2023 IF(K-NS) 2040,2028,2028
2040 K=K+1
      GO TO 2022
2050 CONTINUE
C      INPUT OF GRIDPOINT DATA
      READ 5, NP,NL,H
      5 FORMAT(3HNP=I4,3X,3HNL=I2,3X,2HH=F8.4)
      PRINT 60
      60 FORMAT (1H1,15X,23HLIST OF INTERNAL POINTS,/)
      PRINT 41,NP,NL
      41 FORMAT (5X,25HNUMBER OF INTERNAL POINTS,I4,10X,28HNUMBER OF LOADING
      1G CONDITIONS,I3/)
      PRINT 42,H
      42 FORMAT (5X,13HGRID SPACING,F8.3/)
      DO 1360 LSTRED=1,NP
1360 READ 6, LP(LSTRED),(Q(LSTRED,MSTRED),MSTRED=1,NL)
      6 FORMAT(I6,3F12.4)
C      REARRANGEMENT OF GRIDPOINT LISTING TO MINIMIZE WIDTH OF BAND
C      IN FINAL BAND MATRIX
1729 MINLP1=9999
      MINLP2=9999
      MAXLP1=0000
```

```
MAXLP2=0000
IDIR3=1
DO 1730 I=1,NP
IF(MAXLP1-LP(I)) 1731,1732,1732
1731 MAXLP1=LP(I)
1732 IF(MINLP1-LP(I)) 1733,1733,1734
1734 MINLP1=LP(I)
1733 KTEMP=LP(I)/100
JTEMP=LP(I)-KTEMP*100
LTEMP=JTEMP*100+KTEMP
IF(MAXLP2-LTEMP) 1735,1736,1736
1735 MAXLP2=LTEMP
1736 IF(MINLP2-LTEMP)1730,1730,1737
1737 MINLP2=LTEMP
1730 CONTINUE
MIN3=MAXLP1-MINLP1
MIN2=MAXLP2-MINLP2
IF(MIN3-MIN2) 1738,1739,1739
1739 IDIR3=2
MDIM=((MAXLP1/100-MINLP1/100)+1)*3+2
GO TO 1362
1738 DO 1740 I=1,NP
MDIM=((MAXLP2/100-MINLP2/100)+1)*3+2
KTEMP=LP(I)/100
1740 LP(I)=(LP(I)-KTEMP*100)*100+KTEMP
1362 DO 1720 JSORT=1,NP
DO 1720 I=1,ITEMP
IF(LP(I)-LP(I+1)) 1720,1720,1701
1701 KTEMP=LP(I)
DO 1703 IFT=1,NL
1703 QTEMP(IFT)=Q(I,IFT)
LP(I)=LP(I+1)
DO 1704 IFT=1,NL
1704 Q(I,IFT)=Q(I+1,IFT)
LP(I+1)=KTEMP
DO 1706 IFT=1,NL
1706 Q(I+1,IFT)=QTEMP(IFT)
1720 CONTINUE
GO TO (1749,1751),IDIR3
1749 DO 1750 I=1,NP
KTEMP=LP(I)/100
1750 LP(I)=(LP(I)-KTEMP*100)*100+KTEMP
1751 DO 1702 J=1,NP
1702 PRINT 6, LP(J),(Q(J,MSTRD),MSTRD=1,NL)
C DETERMINATION OF NUMBER OF EQUALLY SPACED POINTS ALONG THE
C BOUNDARY, THEIR SIDENUMBERS, AND THEIR COORDINATES
M=1
DO 2500 J=1,NS
DO 2499 IJ=1,NS
IF(MCONS(2,J)-MC(IJ)) 2499,2498,2499
2499 CONTINUE
2498 X1=CPC(IJ,1)
Y1=CPC(IJ,2)
DO 2497 IK=1,NS
IF(MCONS(3,J)-MC(IK)) 2497,2496,2497
2497 CONTINUE
2496 X2=CPC(IK,1)
```

```
      Y2=CPC(IK,2)
C      COMPUTATION OF LENGTH OF SIDE J IN FEET
      DISTJ=SQRT((X1-X2)**2 + (Y1-Y2)**2)
C      DETERMINATION OF NUMBER OF EQUALLY SPACED POINTS ALONG SIDE J
      XNUM=DISTJ*12.0/H
      NUM=XNUM
      NMPTJ=NUM-1
      IF(NMPTJ) 2407,2407,2408
2407 NMPTJ=0
2408 KTERM=NMPTJ+2
      BNM=NMPTJ
      DPTJ=DISTJ/(BNM+1.0)
C      DETERMINATION OF LBPE, LBPSE, XBPE, YBPE
      DO 2400 K=1,KTERM
      IF(K-1) 2398,2398,2397
2398 LBPE(M)=MCONS(2,J)
      LBPSE(M)=MCONS(1,J)
      XBPE(M)=X1
      YBPE(M)=Y1
      GO TO 2390
2397 IF(K-KTERM) 2396,2395,2395
2396 LBPE(M)=0
      LBPSE(M)=MCONS(1,J)
      XBPE(M)=XBPE(M-1)+DPTJ*COSS(J)
      YBPE(M)=YBPE(M-1)+DPTJ*SINS(J)
      GO TO 2390
2395 LBPE(M)=MCONS(3,J)
      LBPSE(M)=MCONS(1,J)
      XBPE(M)=X2
      YBPE(M)=Y2
2390 M=M+1
2400 CONTINUE
2500 CONTINUE
      MFIN=M-1
1699 I=MATCH(LIST,K,1)
      IF(I-5) 1651,1652,1651
1652 IF(K-3) 1654,1653,1653
1654 PRINT 1656
1656 FORMAT (/13X,88HTHE FINAL CARD,WHICH SHOULD BE A PROBLEM SPECIFIED
1 CARD,IS MISSING OR WRONGLY FORMULATED//15X,27HHOWEVER EXECUTION C
2CONTINUES//)
      INEXT=2
      GO TO 1653
1651 IEXQ=1
      PRINT 1657
1657 FORMAT (/10X,36HMORE DATA IS SUPPLIED THAN REQUIRED.//)
      PRINT 12
12 FORMAT(10X,54HERRORS,AS LISTED,HAVE BEEN FOUND IN THE SUPPLIED DAT
1A.//34H PLEASE CORRECT THESE AND RESUBMIT//57H EXECUTION PHASE DEL
2ETED IN ANTICIPATION OF YOUR NEXT RUN//11H THANK YOU.//////////1H)
1658 I=MATCH(LIST,K,1)
      IF(I-5) 1658,1659,1658
1659 IF(K-3) 1661,1658,1658
1661 GO TO 1001
1653 IF(IEXQ) 1700,1700,1710
1700 PRINT 21
      PRINT 11
```

```

11 FORMAT(1H1,10X,50HNO CONTRADICTIONS ENCOUNTERED IN THE SUPPLIED DA
ITA//5X,31HEXECUTION PHASE WILL NOW BEGIN.//////////10X,8HRESULTS.//)
CALL CHNXIT
1710 PRINT 12
GO TO 800
1900 IEXQ=1
PRINT 13
13 FORMAT(5X,59HTHE FOLLOWING BOUNDARY HAS AN INSUFFICIENT NUMBER OF
SIDES.//)
DO 1901 I=1,NSIDEC
ICR=JSORT-I+1
1901 PRINT 18,MCONS(1,ICR)
GO TO 1050
1910 IEXQ=1
PRINT 14
14 FORMAT(5X,67HTHE NC GIVEN IS INCONSISTENT WITH THE SUPPLIED CONNEC
TIVITY MATRIX.////////)
GO TO 1070
1930 IEXQ=1
PRINT 15,MCONS(ITWICE,JTWICE)
15 FORMAT(5X,21HTHE SAME SIDE NUMBER,I2,24H,IS USED MORE THAN ONCE.//
1//)
GO TO 1100
1940 IEXQ=1
PRINT 16,MCONS(ITWICE,JTWICE)
16 FORMAT(5X,29HTHE SAME CORNER POINT NUMBER,I2,24H,IS USED MORE THAN
1 ONCE.////////)
GO TO 1100
1950 IEXQ=1
PRINT 17
17 FORMAT(5X,39HTHE FOLLOWING BOUNDARY IS DISCONTINUOUS//5X,43HTHIS B
OUNDARY IS COMPRISED OF SIDE NUMBERS-//)
IE=NSC(JCLOSE)
IBCE=0
DO 1951 I=1,IE
1951 IBCE=IBCE+NSC(I)
IBCS=IBCE-NSC(IE)+1
DO 1952 J=IBCS,IBCF
1952 PRINT 18,MCONS(I,J)
18 FORMAT(30X,I6/)
GO TO 1120
1960 IEXQ=1
PRINT 19,MC(ICPRED)
19 FORMAT(5X,17HTHE SIDE NUMBERED,I4,84H MENTIONED IN THE LIST OF BOU
NDARY POINTS,DOES NOT APPEAR IN THE CONNECTIVITY TABLE.//)
GO TO 1130
END

```

LISTS FOR SUBROUTINE MATCH.....LINK1

\$IBMAP	LISTS	REF,LIST
	ENTRY	LIST
	ENTRY	LIST1
LIST1	DEC	7
	BCI	1,0FIXD
	BCI	1,SIMPLE
	BCI	1,0FREE

LINK2.....EXPANSIONS OF BOUNDARY CONDITIONS.

```

DIMENSION MCONS(4,100)
DIMENSION COSS(100)
DIMENSION SINS(100)
DIMENSION AW(21,12)
DIMENSION GJ(100)
DIMENSION SCR(100)
DIMENSION SCD(100)
DIMENSION EI(100)
DIMENSION HOR(100)
DIMENSION TITLE(12)
DIMENSION MC(100)
DIMENSION CPC(100,2)
DIMENSION LBPE(1000)
DIMENSION LBPSE(1000)
DIMENSION XBPE(1000)
DIMENSION YBPE(1000)
DIMENSION LP(1000)
DIMENSION LPC(1000)
DIMENSION Q(1000,3)
DIMENSION KSTAR(30)
DIMENSION MJ(100)
COMMON TITLE,MCONS,MC,CPC,LBPE,LBPSE,XBPE,YBPE,COSS,SINS,LP,LPC,Q,
IINTSW,IEXQ,INEXT,NS,NC,NP,NL,MDIM,H,MFIN,SCR,SCD,DP,POIS,EI,GJ,HOR
REWIND 1
CALL CLGRD(LP,NP,LPC)
DO 3089 I=1,NP
NOBC=0
DO 3044 IT=1,21
DO 3044 JT=1,8
3044 AW(IT,JT)=0.
IF(LPC(IT)-2) 4445,4501,4445
4501 K=1
DO 3090 JSIDE=1,NS
CALL DIST(CPC,H,LP,I,MCONS,JSIDE,D,XD,YD,X1,X2,Y1,Y2,X3,Y3,NS,MC)
CALL SSWTCH(5,KK)
IF(KK-2) 550,553,553
550 PRINT 551, LP(I),MCONS(1,JSIDE),D
551 FORMAT(//20H DISTANCE FROM POINT,I5,8H TO SIDE,I3,2H =,F12.4//)
PRINT 552, XD,YD,X1,X2,Y1,Y2
552 FORMAT(19H XD,YD,X1,X2,Y1,Y2=6F12.4//)
553 IF(D-2.0*H) 4508,3091,3091
C SINCE D LESS THAN 2H,BOUNDARY CONDITIONS FOR SIDE JSIDE ARE NEEDED
4508 KD=1
3110 IF(KD-2) 3120,4509,4510
4509 XD=XD+H*COSS(JSIDE)
YD=YD+H*SINS(JSIDE)
GO TO 3120
4510 IF(KD-4) 4511,4509,4509
4511 XD=XD-2.0*H*COSS(JSIDE)
YD=YD-2.0*H*SINS(JSIDE)
C CHECK TO SEE IF XD,YD ARE ON SIDE
3120 IF(ABS(SINS(JSIDE))-0.707) 3180,3180,3190
3180 IF(XD-X1) 3200,3210,3210

```

```

3200 IF(XD-X2) 3220,3230,3230
3210 IF(XD-X2) 3230,3220,3220
3190 IF(YD-Y1) 3240,3250,3250
3240 IF(YD-Y2) 3220,3230,3230
3250 IF(YD-Y2) 3230,3220,3220
C   SINCE XD,YD ARE ON SIDE, EXPAND B.C. AT THIS POINT
3230 ALFA=(XD-X3)/H
      BETA=(YD-Y3)/H
C   EXPAND BOUNDARY CONDITIONS FOR SIDE AND INSERT INTO AW MATRIX
      DO 4800 LM=1,21
4800 AW(LM,K)=0.
      C=COSS(JSIDE)
      S=SINS(JSIDE)
      LYNN=MCONS(4,JSIDE)
      IF(KD=4) 4600,4700,4700
4600 GO TO (4601,4601,4603,4604,4605,4601), LYNN
C   SIMPLE BC FOR FIXED EDGES, SIMPLY SUPPORTED EDGES, AND
C   FOR SIMPLY SUPPORTED EDGE BEAM
4601 AW(1,K)=1.
      AW(2,K)=ALFA
      AW(3,K)=BETA
      AW(4,K)=ALFA*ALFA/2.
      AW(5,K)=ALFA*BETA
      AW(6,K)=BETA*BETA/2.
      AW(7,K)=(ALFA**3)/6.
      AW(8,K)=ALFA*ALFA*BETA/2.
      AW(9,K)=ALFA*BETA*BETA/2.
      AW(10,K)=(BETA**3)/6.
      AW(11,K)=(ALFA**4)/24.
      AW(12,K)=(ALFA**3)*BETA/6.
      AW(13,K)=(ALFA**2)*(BETA**2)/4.
      AW(14,K)=ALFA*(BETA**3)/6.
      AW(15,K)=(BETA**4)/24.
      AW(16,K)=(ALFA**5)/120.
      AW(17,K)=(ALFA**4)*BETA/24.
      AW(18,K)=(ALFA**3)*(BETA**2)/12.
      AW(19,K)=(ALFA**2)*(BETA**3)/12.
      AW(20,K)=ALFA*(BETA**4)/24.
      AW(21,K)=(BETA**5)/120.
      GO TO 4710
C   SIMPLE BC FOR FREE EDGE
4603 AW(4,K)=(S**2)+POIS*(C**2)
      AW(5,K)=-2.0*S*C*(1.0-POIS)
      AW(6,K)=(C**2)+POIS*(S**2)
      AW(7,K)=ALFA*AW(4,K)
      AW(8,K)=BETA*AW(4,K)+ALFA*AW(5,K)
      AW(9,K)=BETA*AW(5,K)+ALFA*AW(6,K)
      AW(10,K)=BETA*AW(6,K)
      AW(11,K)=(ALFA**2)*AW(4,K)/2.
      AW(12,K)=ALFA*BETA*AW(4,K) + (ALFA**2)*AW(5,K)/2.
      AW(13,K)=(BETA**2)*AW(4,K)/2. + (ALFA**2)*AW(6,K)/2.
      1+ALFA*BETA*AW(5,K)
      AW(14,K)=(BETA**2)*AW(5,K)/2. + ALFA*BETA*AW(6,K)
      AW(15,K)=(BETA**2)*AW(6,K)/2.
      AW(16,K)=(ALFA**3)*AW(4,K)/6.
      AW(17,K)=(ALFA**2)*BETA*AW(4,K)/2. + (ALFA**3)*AW(5,K)/6.
      AW(18,K)=ALFA*(BETA**2)*AW(4,K)/2. + (ALFA**3)*AW(6,K)/6.

```

1+(ALFA**2)*BETA*AW(5,K)/2.
 AW(19,K)=(BETA**3)*AW(4,K)/6. + (ALFA**2)*BETA*AW(6,K)
 1+ALFA*(BETA**2)*AW(5,K)/2.
 AW(20,K)=(BETA**3)*AW(5,K)/6. + ALFA*(BETA**2)*AW(6,K)/2.
 AW(21,K)=(BETA**3)*AW(6,K)/6.
 GO TO 4710

C SIMPLE BC FOR EDGE WITH ELASTIC RESTRAINT

4604 SPR=SCR(JSIDE)/DP
 TM1=S*S+POIS*C*C
 TM2=-2.0*S*C*(1.-POIS)
 TM3=C*C+POIS*S*S
 AW(2,K)=SPR*S
 AW(3,K)=-SPR*C
 AW(4,K)=TM1+ALFA*SPR*S
 AW(5,K)=TM2+BETA*SPR*S-ALFA*SPR*C
 AW(6,K)=TM3-BETA*SPR*C
 AW(7,K)=ALFA*TM1+(ALFA**2)*SPR*S/2.
 AW(8,K)=BETA*TM1+ALFA*TM2+ALFA*BETA*SPR*S-(ALFA**2)*SPR*C/2.
 AW(9,K)=ALFA*TM3+BETA*TM2+(BETA**2)*SPR*S/2.-ALFA*BETA*SPR*C
 AW(10,K)=BETA*TM3-(BETA**2)*SPR*C/2.
 AW(11,K)=(ALFA**2)*TM1/2.+(ALFA**3)*SPR*S/6.
 AW(12,K)=ALFA*BETA*TM1+(ALFA**2)*TM2/2.+(ALFA**2)*BETA*SPR*S/2.
 1-(ALFA**3)*SPR*C/6.
 AW(13,K)=(BETA**2)*TM1/2.+(ALFA**2)*TM3/2.+ALFA*BETA*TM2
 1+ALFA*(BETA**2)*SPR*S/2.-(ALFA**2)*BETA*SPR*C/2.
 AW(14,K)=ALFA*BETA*TM3+(BETA**2)*TM2/2.+(BETA**3)*SPR*S/6.
 1-ALFA*BETA*BETA*SPR*C/2.
 AW(15,K)=(BETA**2)*TM3/2.-(BETA**3)*SPR*C/6.
 AW(16,K)=(ALFA**3)*TM1/6.+(ALFA**4)*SPR*S/24.
 AW(17,K)=(ALFA**2)*BETA*TM1/2.+(ALFA**3)*TM2/6.
 1+(ALFA**3)*BETA*SPR*S/6.-(ALFA**4)*C*SPR/24.
 AW(18,K)=ALFA*(BETA**2)*TM1/2.+(ALFA**3)*TM3/6.+(ALFA**2)*BETA*TM2
 1/2. + ((ALFA*BETA)**2)*SPR*S/4.-(ALFA**3)*BETA*SPR*C/6.
 AW(19,K)=(BETA**3)*TM1/6.+(ALFA**2)*BETA*TM3/2.+ALFA*(BETA**2)*TM2
 1/2.+ALFA*(BETA**3)*SPR*S/6.-(ALFA*BETA)**2)*SPR*C/4.
 AW(20,K)=ALFA*(BETA**2)*TM3/2.+(BETA**3)*TM2/6.+(BETA**4)*SPR*S/24
 1.-ALFA*(BETA**3)*SPR*C/6.
 AW(21,K)=(BETA**3)*TM3/6.-(BETA**4)*SPR*C/24.
 GO TO 4710

C SIMPLE BC FOR FREE EDGE BEAM AND COMPLICATED BC FOR SIMPLY

C SUPPORTED EDGE BEAM

4605 T1=-(S*S+POIS*C*C)
 T2=2.0*S*C*(1.-POIS)
 T3=-(C*C+POIS*S*S)
 T4=GJ(JSIDE)*S*C*C/DP +HOR(JSIDE)*S*(1.+C*C*(1.-POIS))
 T5=GJ(JSIDE)*C*(2.-3.0*C*C)/DP +HOR(JSIDE)*C*(1.-3.0*C*C
 1-POIS*(3.0*S*S-1.0))
 T6=GJ(JSIDE)*S*(3.0*S*S-2.)/DP +HOR(JSIDE)*S*(3.0*S*S-1.0
 1-POIS*(1.-3.0*C*C))
 T7=-GJ(JSIDE)*S*S*C/DP +HOR(JSIDE)*C*(-1.-S*S*(1.-POIS))
 AW(4,K)=T1
 AW(5,K)=T2
 AW(6,K)=T3
 AW(7,K)=ALFA*T1+T4
 AW(8,K)=BETA*T1+ALFA*T2+T5
 AW(9,K)=BETA*T2+ALFA*T3+T6
 AW(10,K)=BETA*T3+T7

AW(11,K)=ALFA*ALFA*T1/2.+ALFA*T4

AW(12,K)=ALFA*BETA*T1+(ALFA**2)*T2/2.+BETA*T4+ALFA*T5

AW(13,K)=(BETA**2)*T1/2.+ALFA*BETA*T2+(ALFA**2)*T3/2.+BETA*T5

1+ALFA*T6

AW(14,K)=(BETA**2)*T2/2.+ALFA*BETA*T3+BETA*T6+ALFA*T7

AW(15,K)=(BETA**2)*T3/2.+BETA*T7

AW(16,K)=(ALFA**3)*T1/6.+(ALFA**2)*T4/2.

AW(17,K)=ALFA*ALFA*BETA*T1/2.+(ALFA**3)*T2/6.+ALFA*BETA*T4

1+ALFA*ALFA*T5/2.

AW(18,K)=ALFA*BETA*BETA*T1/2.+ALFA*ALFA*BETA*T2/2.+(ALFA**3)*T3/6.

1+BETA*BETA*T4/2.+ALFA*BETA*T5+ALFA*ALFA*T6/2.

AW(19,K)=(BETA**3)*T1/6.+ALFA*BETA*BETA*T2/2.+ALFA*ALFA*BETA*T3/2.

1+BETA*BETA*T5/2.+ALFA*BETA*T6+ALFA*ALFA*T7/2.

AW(20,K)=(BETA**3)*T2/6.+ALFA*BETA*BETA*T3/2.+BETA*BETA*T6/2.

1+ALFA*BETA*T7

AW(21,K)=(BETA**3)*T3/6.+BETA*BETA*T7/2.

GO TO 4710

4700 GO TO (4701,4702,4704,4705,4707,4605), LYNN

C COMPLICATED BC FOR FIXED EDGE

4701 AW(2,K)=S

AW(3,K)=-C

AW(4,K)=ALFA*S

AW(5,K)=BETA*S-ALFA*C

AW(6,K)=-BETA*C

AW(7,K)=(ALFA**2)*S/2.

AW(8,K)=ALFA*BETA*S-(ALFA**2)*C/2.

AW(9,K)=(BETA**2)*S/2.-ALFA*BETA*C

AW(10,K)=-(BETA**2)*C/2.

AW(11,K)=(ALFA**3)*S/6.

AW(12,K)=(ALFA**2)*BETA*S/2.-(ALFA**3)*C/6.

AW(13,K)=(BETA**2)*ALFA*S/2.-(ALFA**2)*BETA*C/2.

AW(14,K)=(BETA**3)*S/6.-(BETA**2)*ALFA*C/2.

AW(15,K)=-BETA**3)*C/6.

AW(16,K)=(ALFA**4)*S/24.

AW(17,K)=(ALFA**3)*BETA*S/6.-(ALFA**4)*C/24.

AW(18,K)=((ALFA*BETA)**2)*S/4.-(ALFA**3)*BETA*C/6.

AW(19,K)=ALFA*(BETA**3)*S/6.-(ALFA*BETA)**2)*C/4.

AW(20,K)=(BETA**4)*S/24.-ALFA*(BETA**3)*C/6.

AW(21,K)=-BETA**4)*C/24.

GO TO 4710

C COMPLICATED BC FOR SIMPLY SUPPORTED EDGE

4702 AW(4,K)=1.

AW(6,K)=1.

AW(7,K)=ALFA

AW(8,K)=BETA

AW(9,K)=ALFA

AW(10,K)=BETA

AW(11,K)=(ALFA**2)/2.

AW(12,K)=ALFA*BETA

AW(13,K)=(ALFA**2)/2.+(BETA**2)/2.

AW(14,K)=ALFA*BETA

AW(15,K)=(BETA**2)/2.

AW(16,K)=(ALFA**3)/6.

AW(17,K)=(ALFA**2)*BETA/2.

AW(18,K)=0.5*ALFA*(BETA**2)+(ALFA**3)/6.

AW(19,K)=(BETA**3)/6.+(ALFA**2)*BETA/2.

AW(20,K)=ALFA*(BETA**2)/2.

AW(21,K)=(BETA**3)/6.

GO TO 4710

C COMPLICATED BC FOR FREE EDGE

4704 AW(7,K)=S*(1.0+(C**2)*(1.-POIS))

AW(8,K)=C*(1.0-3.0*(C**2)-POIS*(3.0*(S**2)-1.))

AW(9,K)=S*(3.0*(S**2)-1.0-POIS*(1.0-3.0*(C**2)))

AW(10,K)=C*(-1.-(S**2)*(1.-POIS))

AW(11,K)=ALFA*AW(7,K)

AW(12,K)=BETA*AW(7,K)+ALFA*AW(8,K)

AW(13,K)=BETA*AW(8,K)+ALFA*AW(9,K)

AW(14,K)=BETA*AW(9,K)+ALFA*AW(10,K)

AW(15,K)=BETA*AW(10,K)

AW(16,K)=(ALFA**2)*AW(7,K)/2.

AW(17,K)=ALFA*BETA*AW(7,K)+(ALFA**2)*AW(8,K)/2.

AW(18,K)=(BETA**2)*AW(7,K)/2.+ALFA*BETA*AW(8,K)+(ALFA**2)*AW(9,K)/

12.

AW(19,K)=(BETA**2)*AW(8,K)/2.+ALFA*BETA*AW(9,K)+(ALFA**2)*AW(10,K)

1/2.

AW(20,K)=(BETA**2)*AW(9,K)/2.+ALFA*BETA*AW(10,K)

AW(21,K)=(BETA**2)*AW(10,K)/2.

GO TO 4710

C COMPLICATED BC FOR FLASTICALLY RESTRAINED EDGE

4705 SPD=SCD(JSIDE)/DP

TM1=S*(1.+C*C*(1.-POIS))

TM2=C*(1.-3.0*C*C-POIS*(3.0*S*S-1.))

TM3=S*(3.0*S*S-1.-POIS*(1.-3.0*C*C))

TM4=C*(-1.-S*S*(1.-POIS))

AW(1,K)=SPD

AW(2,K)=ALFA*SPD

AW(3,K)=BETA*SPD

AW(4,K)=(ALFA**2)*SPD/2.

AW(5,K)=ALFA*BETA*SPD

AW(6,K)=(BETA**2)*SPD/2.

AW(7,K)=(ALFA**3)*SPD/6.+TM1

AW(8,K)=(ALFA**2)*BETA*SPD/2.+TM2

AW(9,K)=ALFA*(BETA**2)*SPD/2.+TM3

AW(10,K)=(BETA**3)*SPD/6.+TM4

AW(11,K)=(ALFA**4)*SPD/24.+ALFA*TM1

AW(12,K)=(ALFA**3)*BETA*SPD/6.+BETA*TM1+ALFA*TM2

AW(13,K)=((ALFA*BETA)**2)*SPD/4.+BETA*TM2+ALFA*TM3

AW(14,K)=ALFA*(BETA**3)*SPD/6.+BETA*TM3+ALFA*TM4

AW(15,K)=(BETA**4)*SPD/24.+BETA*TM4

AW(16,K)=(ALFA**5)*SPD/120.+(ALFA**2)*TM1/2.

AW(17,K)=(ALFA**4)*BETA*SPD/24.+ALFA*BETA*TM1+(ALFA**2)*TM2/2.

AW(18,K)=(ALFA**3)*(BETA**2)*SPD/12.+(BETA**2)*TM1/2.

1+ALFA*BETA*TM2+(ALFA**2)*TM3/2.

AW(19,K)=(ALFA**2)*(BETA**3)*SPD/12.+(BETA**2)*TM2/2.

1+ALFA*BETA*TM3+(ALFA**2)*TM4/2.

AW(20,K)=ALFA*(BETA**4)*SPD/24.+(BETA**2)*TM3+ALFA*BETA*TM4

AW(21,K)=(BETA**5)*SPD/120.+(BETA**2)*TM4/2.

GO TO 4710

C COMPLICATED BC FOR FREE EDGE BEAM

4707 T1=S*(1.+C*C*(1.-POIS))

T2=C*(1.-3.0*C*C-POIS*(3.0*S*S-1.))

T3=S*(3.0*S*S-1.-POIS*(1.-3.0*C*C))

T4=C*(-1.-S*S*(1.-POIS))

T5=EI(JSIDE)*(C**4)/DP

```
T6=4.0*EI(JSIDE)*(C**3)*S/DP
T7=6.0*EI(JSIDE)*S*S*C/C/DP
T8=4.0*EI(JSIDE)*C*(S**3)/DP
T9=EI(JSIDE)*(S**4)/DP
AW(7,K)=T1
AW(8,K)=T2
AW(9,K)=T3
AW(10,K)=T4
AW(11,K)=ALFA*T1+T5
AW(12,K)=BETA*T1+ALFA*T2+T6
AW(13,K)=BETA*T2+ALFA*T3+T7
AW(14,K)=BETA*T3+ALFA*T4+T8
AW(15,K)=BETA*T4+T9
AW(16,K)=(ALFA**2)*T1/2.+ALFA*T5
AW(17,K)=ALFA*BETA*T1+(ALFA**2)*T2/2.+BETA*T5+ALFA*T6
AW(18,K)=(BETA**2)*T1/2.+ALFA*BETA*T2+(ALFA**2)*T3/2.+BETA*T6
1+ALFA*T7
AW(19,K)=(BETA**2)*T2/2.+ALFA*BETA*T3+(ALFA**2)*T4/2.+BETA*T7
1+ALFA*T8
AW(20,K)=(BETA**2)*T3/2.+ALFA*BETA*T4+BETA*T8+ALFA*T9
AW(21,K)=(BETA**2)*T4/2.+BETA*T9
4710 KSTAR(K)=0.
      K=K+1
3220 KD=KD+1
      IF(D-1.414*H) 4550,4550,3090
4550 IF(KD-4) 3110,4551,3090
4551 IF(D-H) 3110,3110,3090
3091 NOBC=NOBC+1
3090 CONTINUE
      IF(NOBC-NS) 4444,4445,4445
4445 PRINT 17, LP(I)
      17 FORMAT(/28H NO BCS FORMULATED FOR POINT, I6//)
      GO TO 3089
4444 NBC=K-1
      CALL SSWTCH(5,LL)
      IF(LL-2) 4450,4460,4460
4450 PRINT 100, LP(I),NBC
      100 FORMAT(///29H EXPANSIONS FOR BCS FOR POINT,I7,3X,4HNBC=,I5//)
      PRINT 101, ((AW(IS,JS),JS=1,8),IS=1,21)
      101 FORMAT(8F10.3)
4460 WRITE (1) ((AW(IP,JP),JP=1,8),IP=1,21),NBC
3089 CONTINUE
      CALL CHNXIT
      END
$IRSYS
$IRFTC DIST
      SUBROUTINE DIST (CPC,H,LP,I,MCONS,IDIST,D,XD,YD,X1,X2,Y1,Y2,X3,Y3,
INS,MC)
      DIMENSION CPC(100,2)
      DIMENSION LP(1000)
      DIMENSION MCONS(4,100)
      DIMENSION MC(100)
      ISIDF=MCONS(1,IDIST)
      JSID2=MCONS(2,IDIST)
      KSID2=MCONS(3,IDIST)
      DO 2310 IS=1,NS
      IF(MC(IS)-JSID2)2320,2330,2320
```

2320 IF(MC(IS)-KSID2)2310,2340,2310
2330 JSIDE=IS

GO TO 2310

2340 KSIDF=IS

2310 CONTINUE

X1=CPC(JSIDE,1)

Y1=CPC(JSIDE,2)

X2=CPC(KSIDF,1)

Y2=CPC(KSIDE,2)

CONX=LP(I)

ICONX=LP(I)/100

CON2=ICONX

CONX=(CONX-CON2*100.)

CONY=CON2

X3=CONX*H

Y3=CONY*H

$XD = (X3 * ((X1 - X2) ** 2) + X1 * ((Y1 - Y2) ** 2) - (X1 - X2) * (Y1 - Y2) * (Y1 - Y3)) / (((X1 - X2) ** 2) + ((Y1 - Y2) ** 2))$

$YD = ((Y3 * (Y2 - Y1) ** 2) + (Y1 * (X2 - X1) ** 2) + (X3 * (Y2 - Y1) * (X2 - X1)) - (X1 * (X2 - X1) * (Y2 - Y1))) / (((Y2 - Y1) ** 2) + ((X2 - X1) ** 2))$

D=SQRT((X3-XD)**2+(Y3-YD)**2)

RETURN

END

\$IRFTC CLGRD

SUBROUTINE CLGRD(LP,NP,LPC)

DIMENSION LP(1000)

DIMENSION Q(1000)

DIMENSION LPC(1000)

DO 4000 I=1,NP

DO 4001 M=1,37

CALL RELABS(M,I,LP,LPRA)

DO 4003 J=1,NP

IF(LP(J)-LPRA) 4003,4001,4003

4003 CONTINUE

LPC(I)=2

PRINT 4008, LP(I),LPC(I)

GO TO 4000

4001 CONTINUE

LPC(I)=1

PRINT 4008, LP(I),LPC(I)

4008 FORMAT(7H POINT=,I7,3X,4HLPC=,I4)

4000 CONTINUE

RETURN

END

\$IRFTC RELABS

SUBROUTINE RELABS(M,I,LP,LPRA)

DIMENSION LP(1000)

GO TO (80,81,82,83,84,85,86,87,88,89,90,91,92,93,94,95,96,97,98,99,100,101,102,103,104,105,106,107,108,109,110,111,112,113,114,115,1216),M

80 LPRA=LP(I)

GO TO 120

81 LPRA=LP(I)+1

GO TO 120

82 LPRA=LP(I)-1

GO TO 120

83 LPRA=LP(I)+100

GO TO 120
84 LPRA=LP(I)-100
GO TO 120
85 LPRA=LP(I)+101
GO TO 120
86 LPRA=LP(I)-101
GO TO 120
87 LPRA=LP(I)+99
GO TO 120
88 LPRA=LP(I)-99
GO TO 120
89 LPRA=LP(I)+2
GO TO 120
90 LPRA=LP(I)-2
GO TO 120
91 LPRA=LP(I)+200
GO TO 120
92 LPRA=LP(I)-200
GO TO 120
93 LPRA=LP(I)+102
GO TO 120
94 LPRA=LP(I)-102
GO TO 120
95 LPRA=LP(I)+199
GO TO 120
96 LPRA=LP(I)-199
GO TO 120
97 LPRA=LP(I)+201
GO TO 120
98 LPRA=LP(I)-201
GO TO 120
99 LPRA=LP(I)-98
GO TO 120
100 LPRA=LP(I)+98
GO TO 120
101 LPRA=LP(I)+202
GO TO 120
102 LPRA=LP(I)-202
GO TO 120
103 LPRA=LP(I)+198
GO TO 120
104 LPRA=LP(I)-198
GO TO 120
105 LPRA=LP(I)+3
GO TO 120
106 LPRA=LP(I)-3
GO TO 120
107 LPRA=LP(I)+300
GO TO 120
108 LPRA=LP(I)-300
GO TO 120
109 LPRA=LP(I)+103
GO TO 120
110 LPRA=LP(I)-103
GO TO 120
111 LPRA=LP(I)+299
GO TO 120

```
112 LPRA=LP(I)-299  
GO TO 120  
113 LPRA=LP(I)+301  
GO TO 120  
114 LPRA=LP(I)-301  
GO TO 120  
115 LPRA=LP(I)+97  
GO TO 120  
116 LPRA=LP(I)-97  
120 RETURN  
END
```

LINK3.....ASSEMBLAGE OF DIFFERENCE MOLECULES.

\$IRFTC LINK3

DIMENSION MCONS(4,100)

DIMENSION COSS(100)

DIMENSION SINS(100)

DIMENSION AW(21,34)

DIMENSION GJ(100)

DIMENSION SCR(100)

DIMENSION SCD(100)

DIMENSION EI(100)

DIMENSION HOR(100)

DIMENSION SUM(3)

DIMENSION SUM1(3)

DIMENSION SUM2(3)

DIMENSION SUM3(3)

DIMENSION TITLF(12)

DIMENSION MC(100)

DIMENSION CPC(100,2)

DIMENSION LBPF(1000)

DIMENSION LBPSE(1000)

DIMENSION XBPF(1000)

DIMENSION YBPE(1000)

DIMENSION LP(1000)

DIMENSION LPC(1000)

DIMENSION Q(1000,3)

DIMENSION KSTAR(30)

DIMENSION RDFL(21)

DIMENSION RMXX(21)

DIMENSION RMYX(100)

DIMENSION RMYX(100)

DIMENSION A1(63,63),A2(63,60)

COMMON TITLE,MCONS,MC,CPC,LBPE,LBPSE,XBPE,YBPE,COSS,SINS,LP,LPC,Q,
1INTSW,IEXQ,INEXT,NS,NC,NP,NL,MDIM,H,MFIN,JSIDE,KD,DP,POIS,EI,GJ,HO
2R,SCR,SCD

REWIND 1

REWIND 2

REWIND 3

REWIND 4

C CALCULATE NUMBERS OF ROWS OF SUBMATRICES

NOM=NP/MDIM+1

C CLEAR BAND MATRIX

DO 8200 MAT=1,NOM

DO 8000 I=1,MDIM

DO 8000 J=1,MDIM

A1(I,J)=0.

8000 A2(I,J)=0.

DO 8170 MROW=1,MDIM

C CLEAR RIGHT HAND SIDE OF JUDY

DO 3010 J=1,21

RDFL(J)=0.

RMXX(J)=0.

RMYX(J)=0.

3010 RMYX(J)=0.

C DETERMINE ROW IN LARGE BAND MATRIX AT WHICH WE ARE NOW WORKING

```
ITWO=MDIM*(MAT-1)+MROW
IF(ITWO-NP) 8005,8005,8210
C CLEAR LEFT HAND SIDE OF JUDY
8005 DO 3040 IS=1,30
3040 KSTAR(IS)=0
DO 3031 IR=1,21
DO 3031 JR=1,34
3031 AW(IR,JR)=0.
C IS GRIDPOINT AN INTERIOR POINT OR A BOUNDARY POINT
IF(LPC(ITWO)-2) 4800,4799,4799
C DETERMINATION OF STANDARD OPERATORS
C STANDARD OPERATOR FOR RDEL(J)
4800 I=ITWO
DO 4850 M=1,13
CALL RELABS(M,I,LP,LPRA)
DO 4851 J=1,NP
IF(LPRA-LP(J)) 4851,4872,4851
4851 CONTINUE
4872 IF(M-2) 4852,4853,4854
4852 AL=20.
GO TO 4860
4853 AL=-8.
GO TO 4860
4854 IF(M-6) 4853,4855,4856
4855 AL=2.
GO TO 4860
4856 IF(M-10) 4855,4857,4857
4857 AL=1.
C DETERMINE WHETHER TO READ OPERATOR INTO A1,A2, OR A3 SUBMATRICES
4860 IF(J-MDIM*(MAT-1)) 4861,4861,4862
4861 K=J-MDIM*(MAT-2)
A1(MROW,K)=AL
GO TO 4850
4862 IF(J-MDIM*MAT) 4863,4863,4864
4863 K=J-MDIM*(MAT-1)
A2(MROW,K)=AL
GO TO 4850
4864 K=J-MDIM*MAT
A1(MROW,K)=AL
4850 CONTINUE
DO 4869 LYNN=1,NL
SUM1(LYNN)=0.
SUM2(LYNN)=0.
SUM3(LYNN)=0.
4869 SUM(LYNN)=0.
GO TO 9000
C DETERMINATION OF OPERATORS FOR BOUNDARY POINTS
4799 READ (1) ((AW(I,J),J=1,8),I=1,21),NBC
C DETERMINE COORDINATES OF RELATIVE POINT M
I=ITWO
MI=0
M=1
K=NBC+1
4900 CALL RELABS(M,I,LP,LPRA)
C DOES RELATIVE POINT M LIE ON PLATE SURFACE
DO 4901 J=1,NP
IF(LPRA-LP(J)) 4903,4902,4903
```

4903 IF(J-NP) 4901,4908,4908

4901 CONTINUE

C POINT LIES ON PLATE. GET SERIES EXPANSION FOR POINT

4902 CALL ALBETA(M,ALFA,BETA)

IF(MI) 4906,4905,4906

4905 CALL TSW(ALFA,BETA,K,AW)

KSTAR(K)=LPRA

GO TO 4907

4906 CALL TSMPO(ALFA,BETA,AW,K)

KSTAR(K)=-LPRA

4907 K=K+1

IF(K-31) 4908,4910,4908

4908 IF(M-37) 4904,4909,4909

4904 M=M+1

GO TO 4900

4909 IF(MI) 4911,4911,4910

4911 MI=1

M=2

GO TO 4900

C MOVE RIGHT HAND SIDES INTO AW MATRIX

4910 IF(K-32) 4914,4915,4916

4914 AW(11,K)=1.

AW(13,K)=2.

AW(15,K)=1.

GO TO 4920

4915 AW(4,K)=-1.

AW(6,K)=-POIS

GO TO 4920

4916 IF(K-34) 4918,4917,4917

4918 AW(4,K)=-POIS

AW(6,K)=-1.

4920 K=K+1

GO TO 4910

4917 AW(5,K)=- (1.0-POIS)

CALL SSWTCH(6,MM)

IF(MM-2) 4777,4778,4778

4777 PRINT 553, LP(ITWO)

553 FORMAT(/9H AT POINT,I5,2X,11HBEFORE JUDY//)

DO 554 JT=1,30

554 PRINT 555, (AW(IT,JT),IT=1,21)

555 FORMAT(1X,21F5.1)

4778 CALL JUDY (AW,21,30,KSTAR,NBC,LP,ITWO,IEXQ,4)

PRINT 556, LP(ITWO)

556 FORMAT(/20H AFTER JUDY AT POINT,I5///)

PRINT 599

599 FORMAT(2X,6HDISPL.,6X,3HMXX,7X,3HMY,7X,3HMY,12X,5HPOINT///)

DO 557 J=1,21

557 PRINT 558, (AW(J,I),I=31,34),KSTAR(J)

558 FORMAT(1X,4F10.2,8X,16//)

DO 4919 I=1,21

RDEL(I)=AW(I,31)

RMXX(I)=AW(I,32)

RMYY(I)=AW(I,33)

RMXY(I)=AW(I,34)

4919 CONTINUE

DO 3711 LYNN=1,NL

SUM1(LYNN)=0.

```
SUM2(LYNN)=0.
SUM3(LYNN)=0.
3711 SUM(LYNN)=0.
C READ RDEL(I) INTO BAND MATRIX
DO 5000 I=1,21
IF(KSTAR(I)) 5008,5000,5011
5008 LYNN=-KSTAR(I)
GO TO 5009
5011 LYNN=KSTAR(I)
5009 DO 5001 K=1,NP
IF(LYNN-LP(K)) 5001,5012,5001
5001 CONTINUE
C ELEMENT GOES INTO COLUMN K OF BAND MATRIX
C DETERMINE WHETHER TO READ ELEMENT INTO A1,A2, OR A3 SUBMATRICES
5012 IF(K-MDIM*(MAT-1)) 5002,5002,5003
5002 L=K-MDIM*(MAT-2)
A1(MROW,L)=RDEL(I)
GO TO 5010
5003 IF(K-MAT*MDIM) 5004,5004,5005
5004 L=K-MDIM*(MAT-1)
A2(MROW,L)=RDEL(I)
GO TO 5010
5005 L=K-MAT*MDIM
A1(MROW,L)=RDEL(I)
C DETERMINE EFFECTIVE LOAD AT GRIDPOINT(RHS OF BAND MATRIX)
5010 IF(KSTAR(I)) 5006,5000,5000
C ONLY MULTI-POINT OPERATOR AFFECTS LOAD AT GRIDPOINT
5006 DO 5007 LYNN=1,NL
SUM1(LYNN)=SUM1(LYNN)+RMXX(I)*Q(K,LYNN)
SUM2(LYNN)=SUM2(LYNN)+RMYX(I)*Q(K,LYNN)
SUM3(LYNN)=SUM3(LYNN)+RMYX(I)*Q(K,LYNN)
5007 SUM(LYNN)=SUM(LYNN)+RDEL(I)*Q(K,LYNN)
5000 CONTINUE
9000 DO 3712 KM=1,NL
Q(ITWO,KM)=Q(ITWO,KM)-SUM(KM)
PRINT 560, KM,LP(ITWO)
560 FORMAT(18H LOADING CONDITION,I3,5X,5HPOINT,I5)
3712 PRINT 561, Q(ITWO,KM)
561 FORMAT(15X,15HEFFECTIVE LOAD=F7.2//)
WRITE (3) (KSTAR(I),RMXX(I),RMYX(I),RMYX(I),I=1,21),(SUM1(L),SUM2(L),SUM3(L),L=1,NL)
8170 CONTINUE
GO TO 8175
C IF LAST SUBMATRIX NOT OF ORDER MDIM, ADJUST BAND MATRIX
8210 MBIG=NOM*MDIM
NP1=NP+1
DO 8211 I=NP1,MBIG
K=I-MDIM*(NOM-1)
8211 A2(K,K)=1.0
DO 8071 I=IROW,MBIG
DO 8071 K=1,NL
8071 Q(I,K)=0.0
8175 WRITE (4) ((A2(I,J),J=1,MDIM),I=1,MDIM)
DO 8176 I=1,MDIM
DO 8176 J=1,MDIM
8176 A2(I,J)=0.0
DO 8177 I=1,MDIM
```

```
J=1
DO 8177 K=1,J
A2(I,K)=A1(I,K)
8177 A1(I,K)=0.0
WRITE (2) ((A1(I,J),J=1,MDIM),I=1,MDIM)
8200 WRITE (2) ((A2(I,J),J=1,MDIM),I=1,MDIM)
REWIND 2
REWIND 4
CALL CHNXIT
END
$IRBTC JUDY LIST
SUBROUTINE JUDY(A,JIM1,JIM4,KVECT,NBC,LP,ITWO,IEXQ,NRHS)
DIMENSION A(21,42),KVECT(37),LP(1000)
IF(NRHS-3) 2560,2570,2570
2570 NCHEC=3
GO TO 2580
2560 NCHEC=NRHS
2580 JIM2=JIM4+NRHS
DO 2529 I=1,JIM1
DO 2529 K=1,NRHS
JIM3=JIM4+K
2529 A(I,JIM3)=-A(I,JIM3)
IF(NBC) 2524,2524,2525
2525 NPS=NBC
GO TO 2527
2524 NPS=JIM4
2527 J=1
2515 PIVOT=0.0
DO 2500 IP=J,NPS
DO 2500 JP=J,JIM1
IF(ABS(PIVOT)-ABS(A(JP,IP))) 2501,2500,2500
2501 PIVOT=A(JP,IP)
IPIV=JP
JPIV=IP
2500 CONTINUE
IF(ABS(PIVOT)-.00100)2541,2541,2502
2502 DO 2504 IEXC=1,JIM1
ATEMP=A(IEXC,JPIV)
A(IEXC,JPIV)=A(IEXC,J)
2504 A(IEXC,J)=ATEMP
DO 2505 JEXC=1,JIM2
ATEMP=A(IPIV,JEXC)
A(IPIV,JEXC)=A(J,JEXC)
2505 A(J,JEXC)=ATEMP
ITEMP=KVECT(J)
KVECT(J)=KVECT(JPIV)
KVECT(JPIV)=ITEMP
DO 2506 IKELR=1,JIM2
2506 A(J,IKELR)=A(J,IKELR)/(-1.*PIVOT)
K=J+1
DO 2507 IELSE=1,JIM1
IF(IFLSE-J)2508,2507,2508
2508 DO 2509 JELSE=K,JIM2
2509 A(IELSE,JELSE)=A(IFLSE,JELSE)+(A(IELSE,J)*A(J,JELSE))
2507 CONTINUE
DO 2510 ICOL=1,JIM1
2510 A(ICOL,J)=A(ICOL,J)/PIVOT
```

```
A(J,J)=0.0
A(J,J)=+1.0/PIVOT
J=J+1
IF(J-JIM1-1)2511,2512,2512
2511 IF(J-NPS-1)2513,2514,2514
2514 NPS=NPS+1
2513 IF(NPS-1-JIM4) 2515,2503,2503
2503 DO 2516 I=J,JIM1
      DO 2516 K=1,NCHEC
      JIM3=JIM4+K
      IF(ABS(A(I,JIM3))-0.000100) 2516,2516,2521
2516 CONTINUE
2520 DO 2522 I=J,JIM4
2522 KVECT(I)=0
      DO 2517 I=J,JIM1
      DO 2517 K=1,NRHS
      JIM3=JIM4+K
2517 A(I,JIM3)=0.0
2512 RETURN
2541 DO 2543 I=1,JIM1
      DO 2542 K=1,NCHEC
      JIM3=JIM4+K
      IF(ABS(A(I,JIM3))-0.0001) 2542,2542,2514
2542 CONTINUE
2543 CONTINUE
      GO TO 2520
2521 PRINT 2550,LP(ITWO)
      PRINT 389,J,IPIV,JPIV
      DO 289 I=1,JIM1
289 PRINT 290,(A(I,M),M=1,JIM2)
      PRINT 400,(KVECT(I),I=1,37)
      RETURN
290 FORMAT(/20F6.2)
389 FORMAT (1H1,2HJ=,I4,//6H IPIV=,I4,5HJPIV=I4//)
400 FORMAT (//20I6)
2550 FORMAT (5X,59HTHERE ARE INSUFFICIENT POINTS IN THE NEIGHBOURHOOD O
1F POINT,15,46H TO ASSEMBLE THE REQUIRED DIFFERENCE EQUATION ,/50X1
23HAT THAT POINT//9X,31HHOWEVER EXECUTION WILL CONTINUE/////))
END
$IRFTC ALBETA LIST
SUBROUTINE ALBETA(M,ALFA,BETA)
GO TO (2601,2602,2603,2604,2605,2606,2607,2608,2609,2610,2611,2612
1,2613,2614,2615,2616,2617,2618,2619,2620,2621,2622,2623,2624,2625,
22626,2627,2628,2629,2630,2631,2632,2633,2634,2635,2636,2637,2638,2
3639,2640,2641,2642,2643,2644,2645,2646,2647,2648,2649),M
2601 ALFA=0.0
      BETA= 0.0
      RETURN
2602 ALFA=1.0
      BETA= 0.0
      RETURN
2603 ALFA=-1.
      BETA=0.0
      RETURN
2604 ALFA=0.0
      BETA= 1.0
      RETURN
```

2605 ALFA=0.0
BETA=-1.0
RETURN

2606 ALFA=1.0
BETA= 1.0
RETURN

2607 ALFA=-1.0
BETA=-1.0
RETURN

2608 ALFA=-1.0
BETA= 1.0
RETURN

2609 ALFA=1.0
BETA=-1.0
RETURN

2610 ALFA=2.0
BETA= 0.0
RETURN

2611 ALFA=-2.0
BETA= 0.0
RETURN

2612 ALFA=0.0
BETA= 2.0
RETURN

2613 ALFA=0.0
BETA=-2.0
RETURN

2614 ALFA=2.0
BETA= 1.0
RETURN

2615 ALFA=-2.0
BETA=-1.0
RETURN

2616 ALFA=-1.0
BETA= 2.0
RETURN

2617 ALFA=1.0
BETA= -2.0
RETURN

2618 ALFA=1.0
BETA= 2.0
RETURN

2619 ALFA=-1.0
BETA=-2.0
RETURN

2620 ALFA=2.0
BETA=-1.0
RETURN

2621 ALFA=-2.0
BETA= 1.0
RETURN

2622 ALFA= 2.0
BETA= 2.0
RETURN

2623 ALFA=-2.0
BETA=-2.0
RETURN

2624 ALFA=-2.0
BETA= 2.0
RETURN
2625 ALFA=+2.0
BETA=-2.0
RETURN
2626 ALFA=+3.0
BETA=+0.0
RETURN
2627 ALFA=-3.0
BETA=+0.0
RETURN
2628 ALFA=+0.0
BETA=+3.0
RETURN
2629 ALFA=-0.0
BETA=-3.0
RETURN
2630 ALFA=+3.0
BETA=+1.0
RETURN
2631 ALFA=-3.0
BETA=-1.0
RETURN
2632 ALFA=-1.0
BETA=+3.0
RETURN
2633 ALFA=+1.0
BETA=-3.0
RETURN
2634 ALFA=+1.0
BETA=+3.0
RETURN
2635 ALFA=-1.0
BETA=-3.0
RETURN
2636 ALFA=-3.0
BETA=+1.0
RETURN
2637 ALFA=+3.0
BETA=-1.0
RETURN
2638 ALFA=+3.0
BETA=+2.0
RETURN
2639 ALFA=-3.0
BETA=-2.0
RETURN
2640 ALFA=-2.0
BETA=+3.0
RETURN
2641 ALFA=+2.0
BETA=-3.0
RETURN
2642 ALFA=+2.0
BETA=+3.0
RETURN

2643 ALFA=-2.0
BETA=-3.0

RETURN

2644 ALFA=-3.0
BETA=+2.0

RETURN

2645 ALFA=+3.0
BETA=-2.0

RETURN

2646 ALFA=+4.0
BETA=+0.0

RETURN

2647 ALFA=-4.0
BETA=+0.0

RETURN

2648 ALFA=-0.0
BETA=+4.0

RETURN

2649 ALFA=+0.0
BETA=-4.0

RETURN

END

\$IBFTC TSMPO LIST
SUBROUTINE TSMPO(ALFA,BETA,AW,K)

DIMENSION AW(21,34)

DO 3269 I=1,21

3269 AW(I,K)=0.

AW(11,K)=1.

AW(13,K)=2.

AW(15,K)=1.

AW(16,K)=ALFA

AW(17,K)=BETA

AW(18,K)=2.0*ALFA

AW(19,K)=2.0*BETA

AW(20,K)=ALFA

AW(21,K)=BETA

RETURN

END

\$IBFTC TSW LIST
SUBROUTINE TSW (ALFA,BETA,K,AW)

DIMENSION AW(21,34)

AW(1,K)=1.0

AW(2,K)=ALFA

AW(3,K)=BETA

AW(4,K)=ALFA*ALFA/2.0

AW(5,K)=ALFA*BETA

AW(6,K)=BETA*BETA/2.0

AW(7,K)=(ALFA**3)/6.0

AW(8,K)=ALFA*ALFA*BETA/2.0

AW(9,K)=ALFA*BETA*BETA/2.0

AW(10,K)=(BETA**3)/6.0

AW(11,K)=(ALFA**4)/24.0

AW(12,K)=(ALFA**3)*BETA/6.0

AW(13,K)=(ALFA**2)*(BETA**2)/4.0

AW(14,K)=ALFA*(BETA**3)/6.0

AW(15,K)=(BETA**4)/24.0

AW(16,K)=(ALFA**5)/120.0

```
AW(17,K)=(ALFA**4)*BETA/24.0  
AW(18,K)=(ALFA**3)*(BETA**2)/12.0  
AW(19,K)=(ALFA**2)*(BETA**3)/12.0  
AW(20,K)=ALFA*(BETA**4)/24.0  
AW(21,K)=(BETA**5)/120.0  
RETURN  
END
```