

A MAN-INTERACTIVE SIMULATOR SYSTEM  
FOR ABOVE-KNEE PROSTHETICS STUDIES

by

WOODIE C. FLOWERS

B.S.M.E., Louisiana Polytechnic Institute  
(1966)

S.M., Massachusetts Institute of Technology  
(1968)

M.E., Massachusetts Institute of Technology  
(1971)

SUBMITTED IN PARTIAL FULFILLMENT  
OF THE REQUIREMENTS FOR THE  
DOCTOR OF PHILOSOPHY

at the

MASSACHUSETTS INSTITUTE OF TECHNOLOGY

August 1972

Signature of Author.....  
Department of Mechanical Engineering  
August 22, 1972

Certified by.....

.....  
Thesis Supervisor

Accepted by.....  
Chairman, Departmental Committee of Graduate Studies



A MAN-INTERACTIVE SIMULATOR SYSTEM  
FOR ABOVE-KNEE PROSTHETIC STUDIES

by

WOODIE C. FLOWERS

Submitted to the Department of Mechanical Engineering  
on August 22, 1972, in partial fulfillment of the  
requirements for the Degree of Doctor of Philosophy.

ABSTRACT

Improvements in the function of prosthetic devices for persons having above-knee amputations must involve both the development of better artificial knee mechanisms and the establishment of a more complete cybernetic link between the amputee and his prosthesis. To facilitate progress in both of these areas, a man-interactive simulator system has been designed and constructed. The simulator system is analogous to flight simulators used to evaluate aircraft and spacecraft controllability. Essentially, an amputee wears an above-knee prosthesis with dimensions and weight similar to typical artificial legs, but having a knee mechanism that is controlled by an analog and/or digital simulation of proposed hardware and control schemes. Through use of the system, prosthetic knee mechanism designs can be evaluated and refined before the hardware is developed. The simulator will first be used in a feasibility study of proportional, electromyographically-controlled knee mechanisms.

An electro-hydraulic servo actuator is used to control the simulator prosthesis knee joint. A performance evaluation has shown that the actuator capabilities allow simulation of existing knee mechanisms and expected proposed designs. Initial tests show that the actuator is easily interfaced with bioelectric signals.

Thesis Supervisor: Robert W. Mann  
Title: Germeshausen Professor

DOCTORAL COMMITTEE

SUPERVISOR

Robert W. Mann, Sc.D.  
Germeshausen Professor  
Massachusetts Institute of Technology

COMMITTEE MEMBERS

Melvin J. Glimcher, M.D.  
Orthopedist-in-Chief  
The Children's Hospital

Phillip F. Meyfarth, Ph.D.  
Engineering Consultant

Borivoje B. Mikic, Sc.D.  
Professor  
Massachusetts Institute of Technology

Thomas B. Sheridan, Sc.D.  
Professor  
Massachusetts Institute of Technology

ACKNOWLEDGMENTS

I would like to thank my wife Margaret for her incredible tolerance and patience.

To Professor Mann, I am most grateful for his influence. He invited me to M.I.T., introduced me to biomedical engineering and the topic of this thesis, and guided me through the research effort.

The most detailed and continuous assistance came from fellow students. If I gave credit for each of their contributions, what I had contributed might appear negligible. I thank them.

I am grateful to Professor T.B. Sheridan, Professor B.B. Mikic, and Doctor M.J. Glimcher for serving on the Doctoral Committee. Their suggestions and comments have been most valuable.

Special thanks are due to Phil Meyfarth for spending many hours organizing my thoughts.

This project has been funded by the National Science Foundation Grant K31230.

TABLE OF CONTENTS

	<u>Page</u>
ABSTRACT.....	2
DOCTORAL COMMITTEE.....	3
ACKNOWLEDGMENTS.....	4
TABLE OF CONTENTS.....	5
LIST OF FIGURES.....	7
Chapter 1 - INTRODUCTION.....	10
Prostheses and the Scope of this Thesis.....	10
Basic Requirements for A/K Prosthesis Knee Mechanisms.....	11
Why Man-Interactive Simulation?.....	15
Chapter 2 - BACKGROUND.....	18
Swing Control.....	18
Stance Control.....	28
Knee Mechanism Summary.....	28
Voluntary Knee Mechanism Control.....	28
EMG Control.....	33
Chapter 3 - SELECTION AND PRELIMINARY EVALUATION OF A KNEE TORQUE CONTROLLER.....	37
Chapter 4 - DESCRIPTION OF THE SIMULATOR SYSTEM.....	46
The Prosthesis and Feedback Elements.....	46
The Hydraulic System.....	61
Electrical System.....	64
Chapter 5 - PERFORMANCE EVALUATION.....	67
Case 1 - Locked Knee.....	67
Case 2 - Free Swinging.....	67
Case 3 - Controlled Damper.....	76

	<u>Page</u>
Case 4 - Powered Knee.....	81
Performance Summary.....	84
EMG Control Demonstrations.....	84
Chapter 6 - SUMMARY AND SUGGESTIONS.....	88
REFERENCES.....	90
BIOGRAPHICAL NOTE.....	93

LIST OF FIGURES

<u>Figure No.</u>	<u>Title</u>	<u>Page</u>
1-1	BEHAVIOR OF AN UNDAMPED KNEE HINGE DURING SWING PHASE	14
2-1	TYPICAL CONSTANT-FRICTION SWING CONTROL MECHANISM	19
2-2	NORTHWESTERN UNIVERSITY INTERMITTENT FRICTION SWING CONTROL UNIT	21
2-3	SCHEMATIC OF ORFICE-FLOW SWING PHASE DAMPER	22
2-4	HYDRAULIC SWING CONTROL UNITS	23
2-5	SCHEMATIC OF THE UCB PNEUMATIC SWING CONTROL UNIT	25
2-6	KNEE-MOMENT PROFILES OF TYPICAL SWING CONTROL UNITS IN COMPARISON WITH AN "IDEAL" PROFILE (25)	26
2-7	STANCE STABILITY RESULTING FROM ALIGNMENT AND HYPEREXTENSION STOPS	29
2-8	MULTIAXIS KNEE JOINT DESIGNED FOR ADDED STANCE STABILITY	30
2-9	SCHEMATIC OF WEIGHT-BEARING KNEE LOCK IN THE UNLOCKED POSITION	31
2-10	OUTLINE OF KNEE MECHANISM FUNCTION (20)	32
3-1	SERVO ACTUATOR IN TORQUE CONTROL CONFIGURATION	39
3-2	ILLUSTRATION OF THE EXPERIMENTAL PROSTHESIS FITTED TO NORMAL LIMB	40
3-3	EXPERIMENTAL PROSTHESIS	42
3-4	CHANGING RATIO OF $\Delta x$ AND $\Delta \theta$	43
3-5	LOAD CELL FOR EXPERIMENTAL PROSTHESIS	45

<u>Figure No.</u>	<u>Title</u>	<u>Page</u>
4-1	OVERALL SYSTEM SCHEMATIC	47
4-2(A)	ASSEMBLED SIMULATOR SYSTEM PROSTHESIS	48
4-2(B)	ASSEMBLED SIMULATOR SYSTEM PROSTHESIS	49
4-3	PROSTHETIC KNEE JOINT RANGE OF ROTATION	50
4-4	PROSTHESIS FRAME	52
4-5	UPPER KNEE BRACKET	53
4-6	TORQUE COUPLER	54
4-7	MANIFOLD AND CYLINDER UNIT	55
4-8	SERVO VALVE	57
4-9	KNEE POSITION TRANSDUCER	58
4-10	VELOCITY TRANSDUCER	59
4-11	LOAD CELL	60
4-14	OVERHEAD CART HYDRAULIC SYSTEM	62
4-15	OPERATIONAL MODES FOR SAFETY VALVE	63
4-16	SCHEMATIC OF ELECTRICAL SYSTEM	65
4-17	MAIN CONTROL CABINET	66
4-18	OVERHEAD CART ELECTRICAL COMPONENTS	66
5-1	FOUR POSSIBLE MODES OF OPERATION FOR KNEE MECHANISM	68
5-2	PENDULUM MODEL OF PROSTHESIS	70
5-3	PROSTHESIS RESPONSE TO OSCILLATING FORCE ON SHANK	73
5-4	STEP RESPONSE IN FREE-SWING MODE	75



<u>Figure No.</u>	<u>Title</u>	<u>Page</u>
5-5	FLOW RESISTANCES IN HYDRAULIC CIRCUIT	78
5-6	ACTUATOR RESPONSE IN PASSIVE MODE	80
5-7	ACTUATOR RESPONSE IN THE ACTIVE MODE	82
5-8	ACTUATOR RESPONSE WITHOUT FORCE FEEDBACK	83
5-9	SUMMARY OF PERFORMANCE LIMITS FOR SIMULATOR SYSTEM	85
5-10	EMG CONTROL DEMONSTRATION SCHEMATIC	86

Chapter 1

INTRODUCTION

Prostheses and The Scope of This Thesis

Trauma, disease, congenital anomalies and age lead to physiological deficiencies involving loss or diminished function of parts of the human body. Unless these causes are eliminated, or purely organic replacement and substitution techniques are developed, prosthetic and orthotic devices must be employed to sustain life and/or provide partial restoration of "normal" function. Progress in this field requires improved devices and techniques as well as establishing a more complete cybernetic link between the prosthesis and its user. This thesis deals with a microcosm of prosthetic development. Its focus is on control of the "knee joint" of articulated artificial legs used by persons having above-knee (A/K) amputations.

Assuming that the goal is emulation of the replaced normal limb, tremendous improvements are yet to be made. It is a testimonial to the elegance and sophistication of the human body to note that despite thousands of man-years of effort, "state-of-the-art" practice produces artificial legs that require the amputee to significantly compromise his mobility and comfort.

A typical A/K prosthesis consists of a socket, a knee unit, a shank, and an ankle-foot unit. It is the produce of research encompassing topics ranging from surgical techniques to psychological

conditioning of amputees. These efforts produce a slowly changing definition of "current practice". The work described herein is the first phase of an effort to develop a knee mechanism that is compatible with current practice, while providing the amputee with additional voluntary knee control. It is hoped that "natural" control can result from properly interfacing the knee mechanism with electromyographic (EMG) signals from the amputee's remaining musculature.

In particular, the subject of this thesis is the description of a man-interactive simulator system designed and constructed to facilitate research on EMG-controlled knee mechanisms. This system was created in order to provide a test bed for realistic evaluation of knee control concepts and to allow evaluation of hardware designs proposed for the implementation of such control schemes.

The remainder of this chapter gives an explanation of the basic function of a knee mechanism and explains why the man-interactive simulation technique was chosen. Chapter 2 provides background information on knee mechanism function and EMG control of prostheses. Chapter 3 discusses preliminary experiments concerning the interface between the simulated portion of the system and the amputee-hardware portion. Chapters 4, 5, and 6 discuss the construction and evaluation of the final system.

#### Basic Requirements for A/K Prosthesis Knee Mechanisms

Only a brief discussion of the functional requirements for A/K prostheses will be presented. This section is provided for those not

familiar with the vernacular. A more complete treatment can be found in the following texts:

- 1) Klopsteg and Wilson et al. Human Limbs and Their Substitutes. New York: Hafner, 1968.
- 2) Wilson A. Bennett, Jr. "Recent Advances in Above-Knee Prosthetics," Artificial Limbs, Vol. 12, Autumn, 1968.

Normal gait is very harmonious and involves precise timing and continuous balanced energy transfer among the body parts. The legs and lower body skeletal members form linkages that change lengths and velocities so that the center of gravity of the head, arms, and body rises and falls only slightly. This oscillation is similar to that of a conservative pendulum<sup>(18)</sup>. Small variations in this pattern cause increased energy consumption<sup>(4)</sup> and are easily detected by an observer. Considerable gait changes can be caused by as trivial an alteration as a poorly fitted shoe. One can see, therefore, that stringent requirements must be met if an amputee is to approach "natural" gait. Many of these requirements are not directly related to the knee joint function and will not be discussed here.

The walking cycle consists of two main phases: the stance (weight-bearing) phase, representing approximately 65% of one cycle, and the swing phase wherein the body is supported completely by the opposite leg. The period in which both feet contact the ground is referred to as double support.

The first requirement for an A/K prosthesis is that it not collapse during stance. This does not mean, however, that locking the knee throughout stance is optimum. In normal gait, the knee joint is fully extended at heel contact. It then flexes slightly and re-extends during weight-bearing. This action allows the hip to follow a more harmonic path and therefore requires less energy consumption.

In the swing phase, a passive A/K prosthesis can be considered as a pendulum subjected to driving forces by the hip. See Figure 1-1. At the beginning of the swing, the upper part of the artificial leg is subjected to a forward acceleration. If no resisting moment is applied by the knee mechanism, an excessive heel rise will occur. Also, at the end of swing, the shank will have a high rotational velocity and must stop abruptly. Both problems become more serious as walking speed increases. Therefore, the minimum requirement is that some damping be provided for the knee during the swing phase. Detailed analyses of optimum swing control have been published and are discussed in Chapter 2.

Aside from these very basic functional requirements knee mechanisms must:

- Be safe and reliable.
- Be cosmetically acceptable.
- Not be too heavy.
- Allow the user to climb and descend stairs and ramps.
- Not demand excessive energy input during walking.
- Flex for sitting.

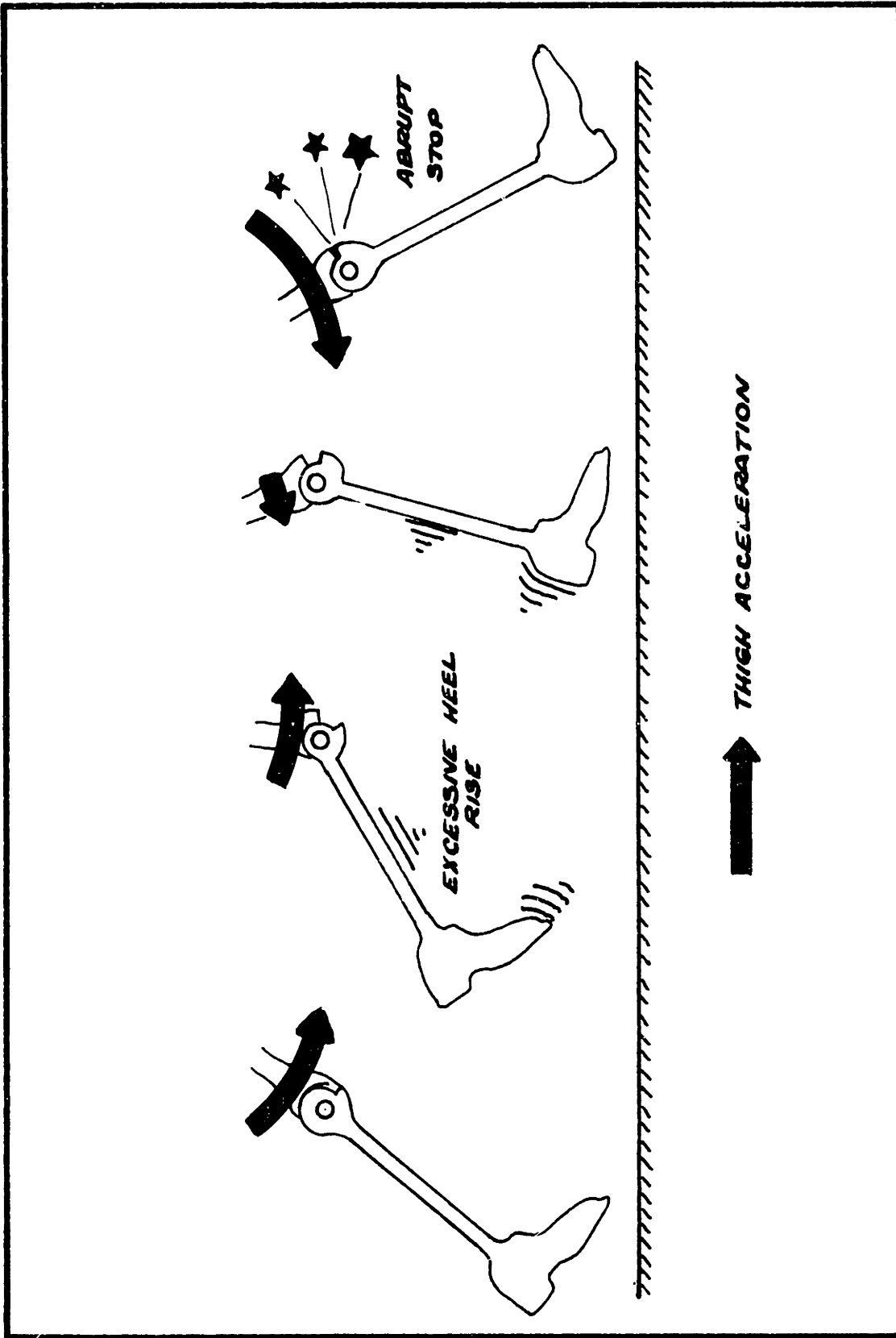

Figure 1-1 BEHAVIOR OF AN UNDAMPED KNEE HINGE DURING SWING PHASE

Why Man-Interactive Simulation?

Paul<sup>(15)(16)</sup> and Morrison<sup>(12)(13)(14)</sup> conducted studies which illustrated the kinematics and dynamics of the muscles controlling the hip and knee movements in normal persons under various walking conditions. They developed dynamic modeling techniques which predicted the geometry and loading of the human leg as a function of time. Also, EMG data was correlated with the models. Several different publications offered optimum dynamic characteristics for A/K swing control devices<sup>(11)(17)(23)</sup>.

At first it seemed, therefore, that all the information was available for a mathematically modeled computer simulation of an amputee-prosthesis combination. The models established by Paul and Morrison could be modified to predict the behavior of the stump of an amputated leg and then be properly coupled to a mathematical model of an A/K prosthesis with an ideal knee mechanism. This overall system would then define the control system transfer functions required for "natural" EMG control, i.e. define the performance criteria for an "MIT Knee".

Further study revealed that the solution is not that straightforward. The absence of a skeletal link makes the interface between the amputee and his prosthesis difficult to describe mathematically. Man's complex adaptive and learning capabilities must be included as an input and are virtually impossible to adequately model. Also, a meaningful feasibility study for a lower limb prosthesis must include evaluation of acceptability by and safety of the amputee, in contingent situations.

These and other complications suggested that another approach had to be devised.

The system described in this thesis appears to offer a viable approach to an EMG-controlled knee mechanism feasibility study. It is a compromise between a complete simulation and the traditional "build it and try it" technique. The man is retained in his essential role in the system while the more readily modeled components are replaced by simulation. The amputee wears an A/K prosthesis with dimensions, weight, and function similar to present limbs, but controlled through an umbilical line. The umbilical also transmits the dynamic state of the prosthesis, as well as selected EMG signals to a computer model of the controller under study. The model output then effects knee torque control. This system allows evaluation of proposed control schemes and mechanisms by an amputee moving about in an environment representative of actual conditions without necessitating construction of the device under study. There is a strong analog between this system and flight simulators used to evaluate the controllability of aircraft and spacecraft. The purpose of both systems is the same: to obtain as much information as possible about the feasibility of proposed designs before undertaking the expensive and laborious task of transforming ideas into hardware.

As design of the amputee-interactive simulator progressed, it became obvious that such a facility would be a valuable tool for other prosthetics research topics. With this in mind, the design effort was expanded to assure that the system be as flexible as possible.



At the beginning of the project, it was hoped that this thesis would present a qualitative and quantitative evaluation of EMG controlled knee joints. That schedule was too optimistic. At this point, only the technique and facility for the study have been developed. Specific studies have been temporarily postponed in the interest of enhancing the general applicability of the system. Plans and financial support exist for a continuing effort.

## Chapter 2

### BACKGROUND

"Probably no other component of artificial limbs has received as much attention from designers and 'gadgeteers' as the knee joint. Several hundred patents have been issued for knee designs..."<sup>(25)</sup> Even a condensed description of the multitude of knee mechanisms would be laborious and in many cases redundant. Therefore, representative types will be presented. Swing and stance control traditionally have been considered independent functions and most devices were designed to accomplish one or the other. For that reason, they will be discussed separately.

#### Swing Control

Swing control devices have utilized dry friction and turbulent fluid flow for energy dissipation. Units providing energy storage during part of the swing employ either mechanical or compressible fluid springs.

The simplest device is the "constant friction" type. See Figure 2-1. Resistance to rotation is provided by friction between the knee bolt, which rotates with the shank, and a mating surface fixed to the upper leg. Adjustment of the resistive torque is provided by varying the contact force in the brake. Once set, this system produces a constant resistive force independent of walking speed and angle of flexion. Typical early brakes employed steel and leather. Recently more wear-

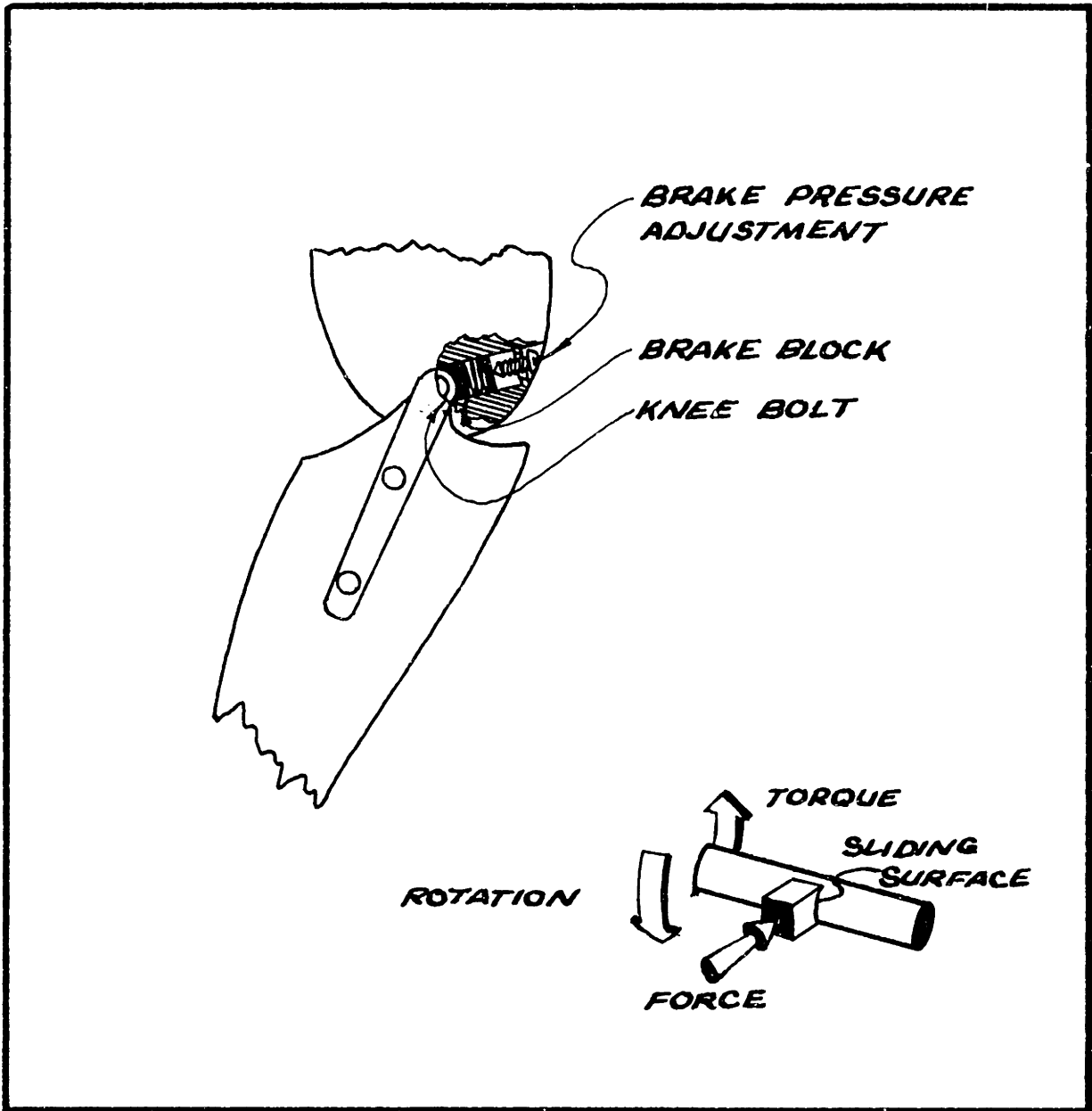

Figure 2-1 TYPICAL CONSTANT-FRICTION SWING CONTROL MECHANISM

resistant materials have been offered<sup>(22)</sup>. In most cases "bumper" springs have been provided to help control deceleration at the end of swing.

In order to provide resistive torque that is a function of knee flexion angle, "intermittent friction" brakes were developed<sup>(7)(20)(22)</sup>. In essence, a programmed torque results from engaging different numbers of friction elements or varying the "clamping" force during the swing phase. A typical device is illustrated in Figure 2-2. Even though such devices provide a better torque profile than the constant-friction type, they function best at only one cadence and are purely dissipative.

Recently, mechanisms having orifice-flow damping have received much attention. If the spatial gait pattern is a weak function of cadence and the driving forces exerted on the shank during swing are due only to accelerations, the required damping forces should be proportional to the square of the cadence<sup>(11)(23)</sup>. This condition is satisfied by a dashpot configured as in Figure 2-3.

The Henschke-Mauch and DuPaCo "Hermes" units (See Figure 2-4) are well-developed examples of this type. They contain flow channels and orifices that are much more complex than the schematic in Figure 2-3. Intraphasic resistance change is accomplished by exposing different orifices as the piston moves. Check valves switch fluid flow to separate channels for extension and flexion, thereby allowing independent adjustment of flexion and extension resistance. A spring is incorporated for extension bias, thus providing increased stability and allowing energy storage and release during heel rise and swing through.

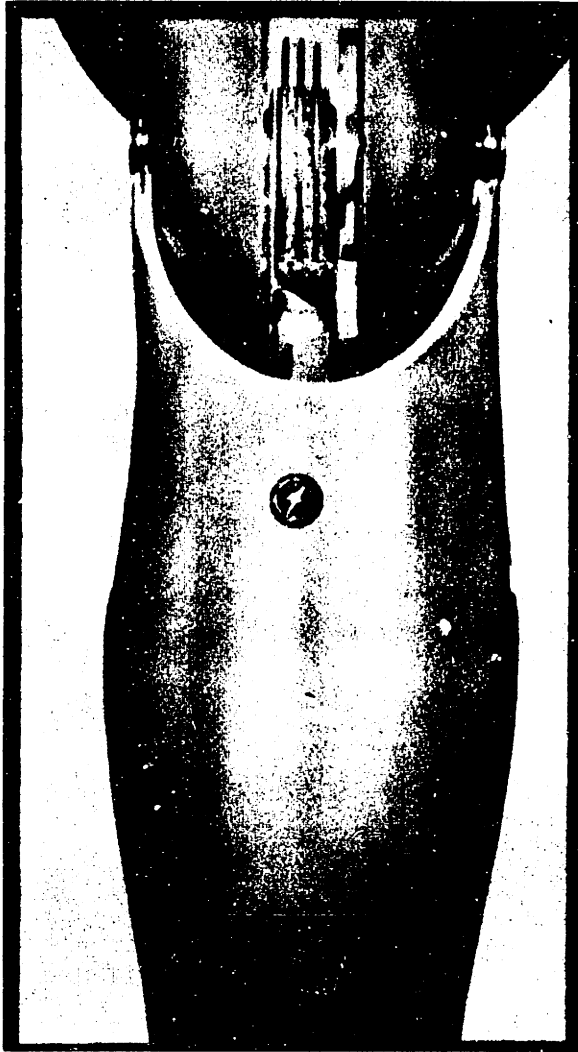

Figure 2-2 NORTHWESTERN UNIVERSITY INTERMITTENT  
FRICTION SWING CONTROL UNIT

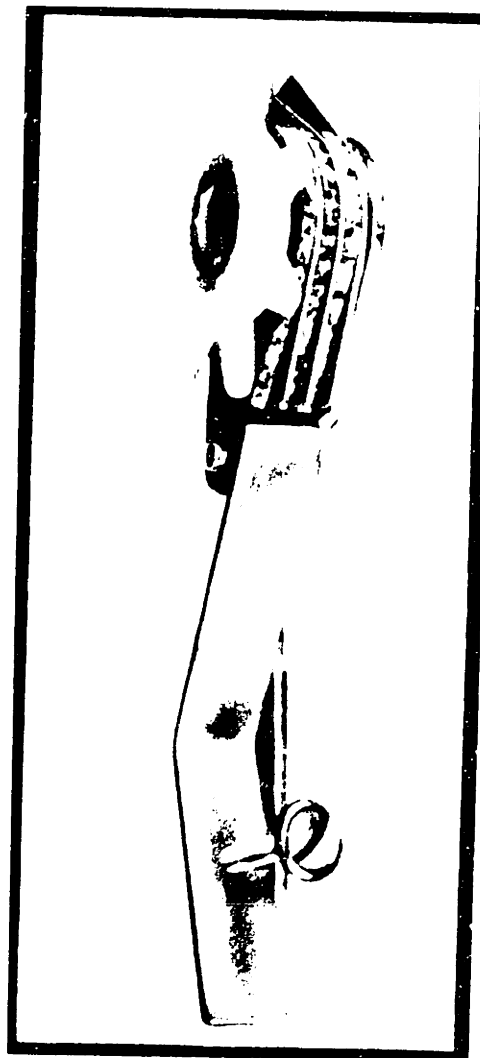
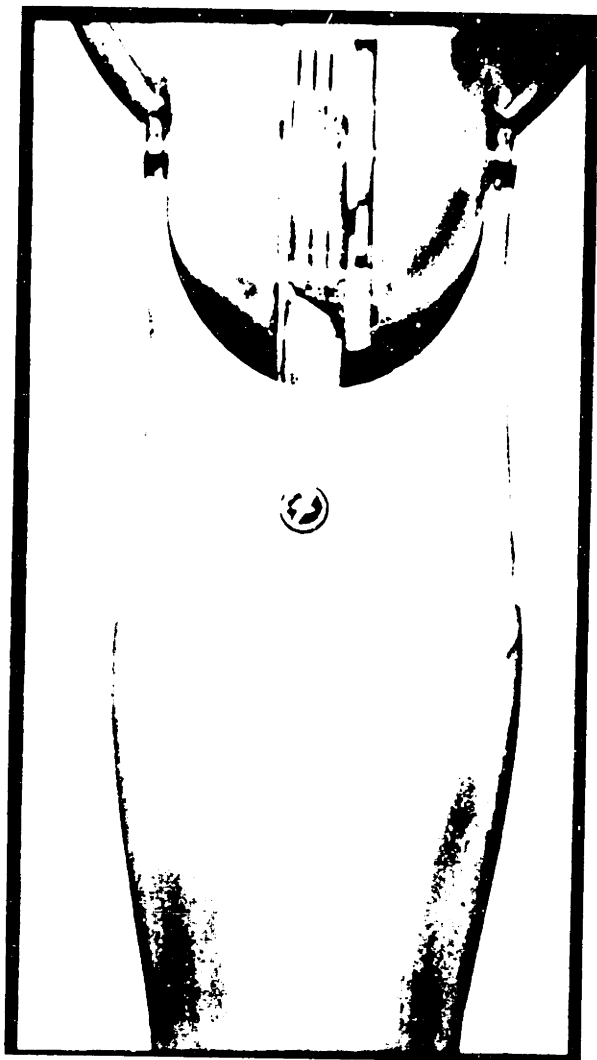

Figure 2-2 NORTHWESTERN UNIVERSITY INTERMITTENT  
FRICTION SWING CONTROL UNIT

INTENTIONAL DUPLICATE EXPOSURE

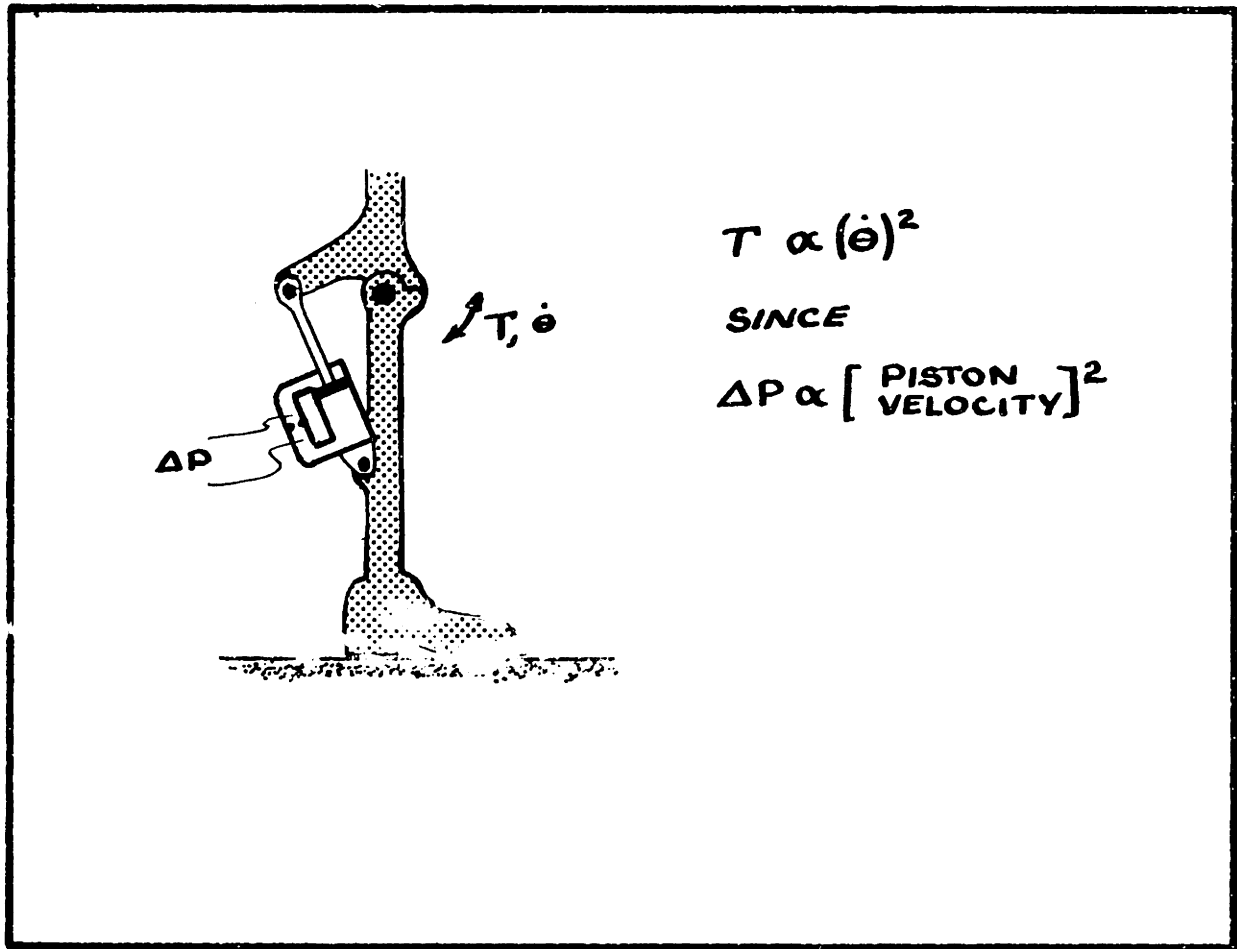
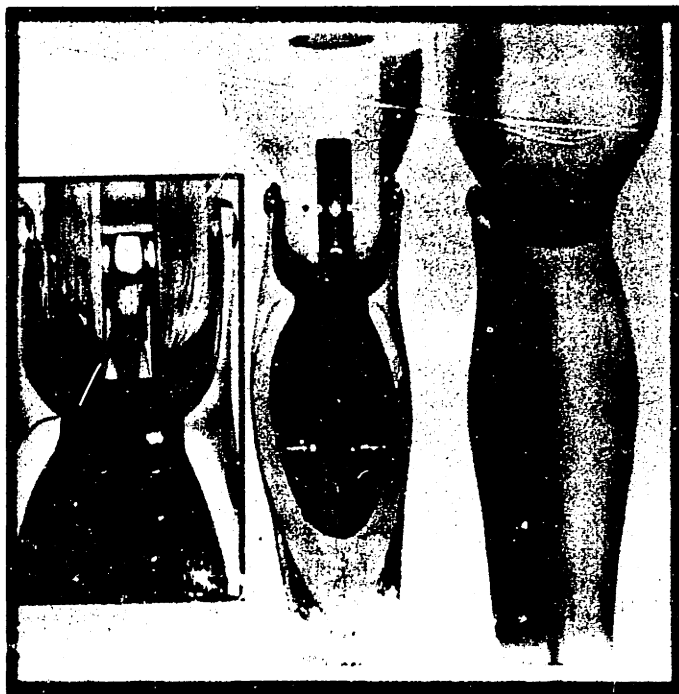
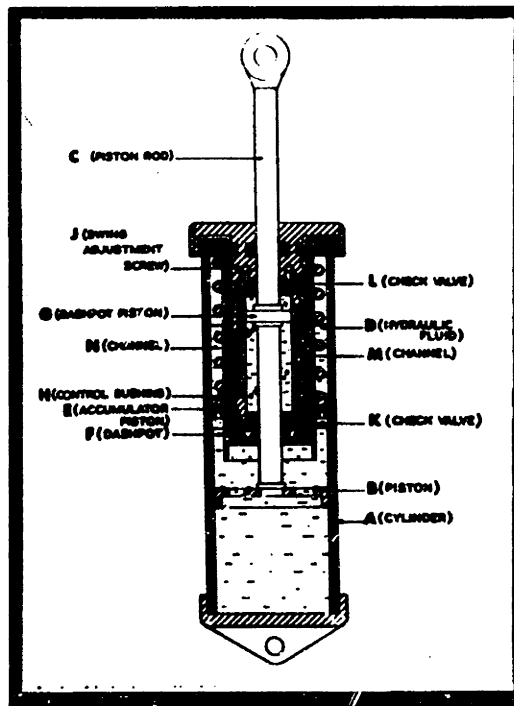

Figure 2-3 SCHEMATIC OF ORFICE-FLOW SWING PHASE DAMPER



A) DuPaCo "Hermes"  
Hydraulic Swing  
Phase Unit in  
Wooden Prosthesis  
Assembly



B) Henschke-Mauch Swing Hydraulic Swing Control Unit

Figure 2-4 HYDRAULIC SWING CONTROL UNITS



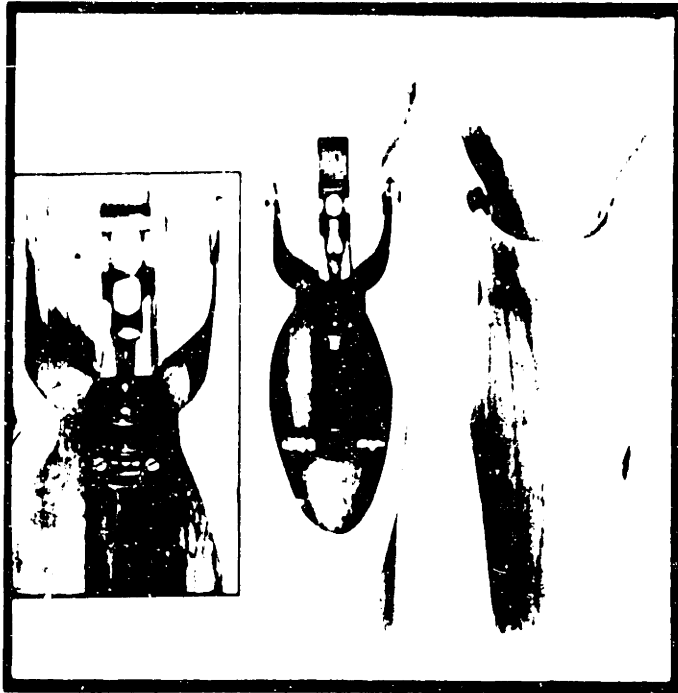

A) DuPaCo "Hermes"  
Hydraulic Swing  
Phase Unit in  
Wooden Prosthesis  
Assembly

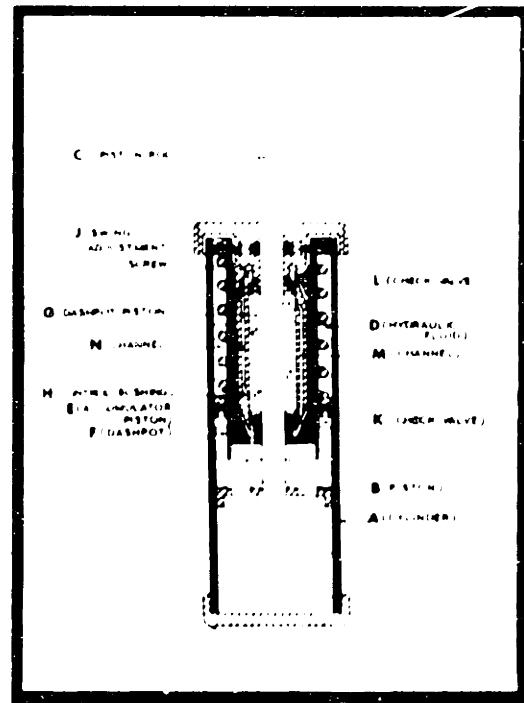
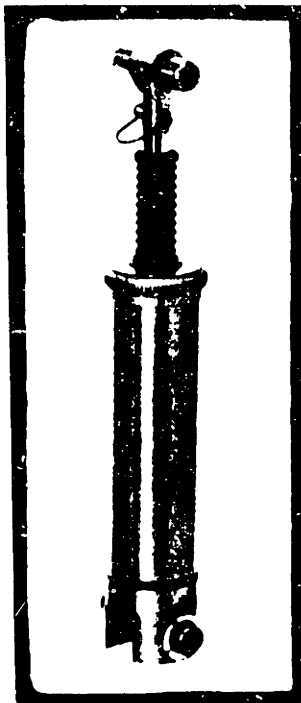

B) Henschke-Mauch Swing Hydraulic Swing Control Unit

Figure 2-4 HYDRAULIC SWING CONTROL UNITS

A fourth type of control unit utilizes an air dashpot. A schematic of the UCB A/K swing control system is shown in Figure 2-5. The main advantage of such units is that fluid leakage is not important and therefore the cost of manufacturing is lowered. The air in the cylinder serves both as an energy dissipator and a spring.

Figure 2-6 compares the knee moment profile of 5 representative devices with an "ideal" profile. This ideal profile was established from the observation of normal subjects<sup>(17)</sup>. It should be emphasized that this comparison is not meant to show which unit is most desirable. Clinical evaluation of these devices must take into account other factors, many of which involve subjective judgments by the amputees. It does seem safe to say, however, that the pneumatic and hydraulic units offer great promise.

Several studies have been conducted to establish the optimum swing-phase, knee-mechanism behavior<sup>(11)(17)(23)</sup>. Also, Morrison<sup>(12)</sup> investigated the power absorbed and produced by normal knee joints during several walking situations. These studies are in close agreement on the following points:

- A. The average energy flow over one swing cycle is "into" the knee joint. Therefore, if energy storage and release capability is available, there would be no need for an external power input.
- B. The intraphasic torque profile can be described as follows:

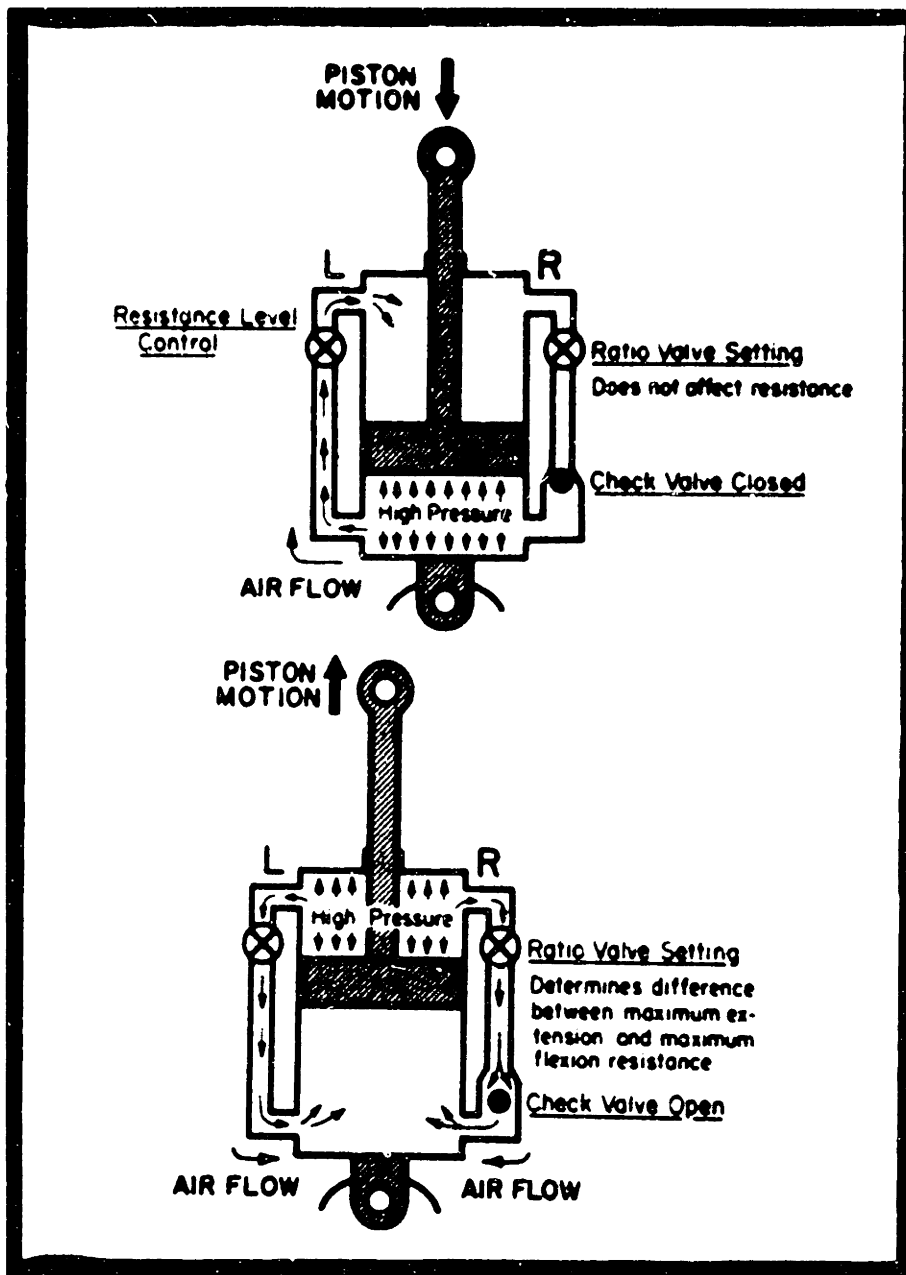
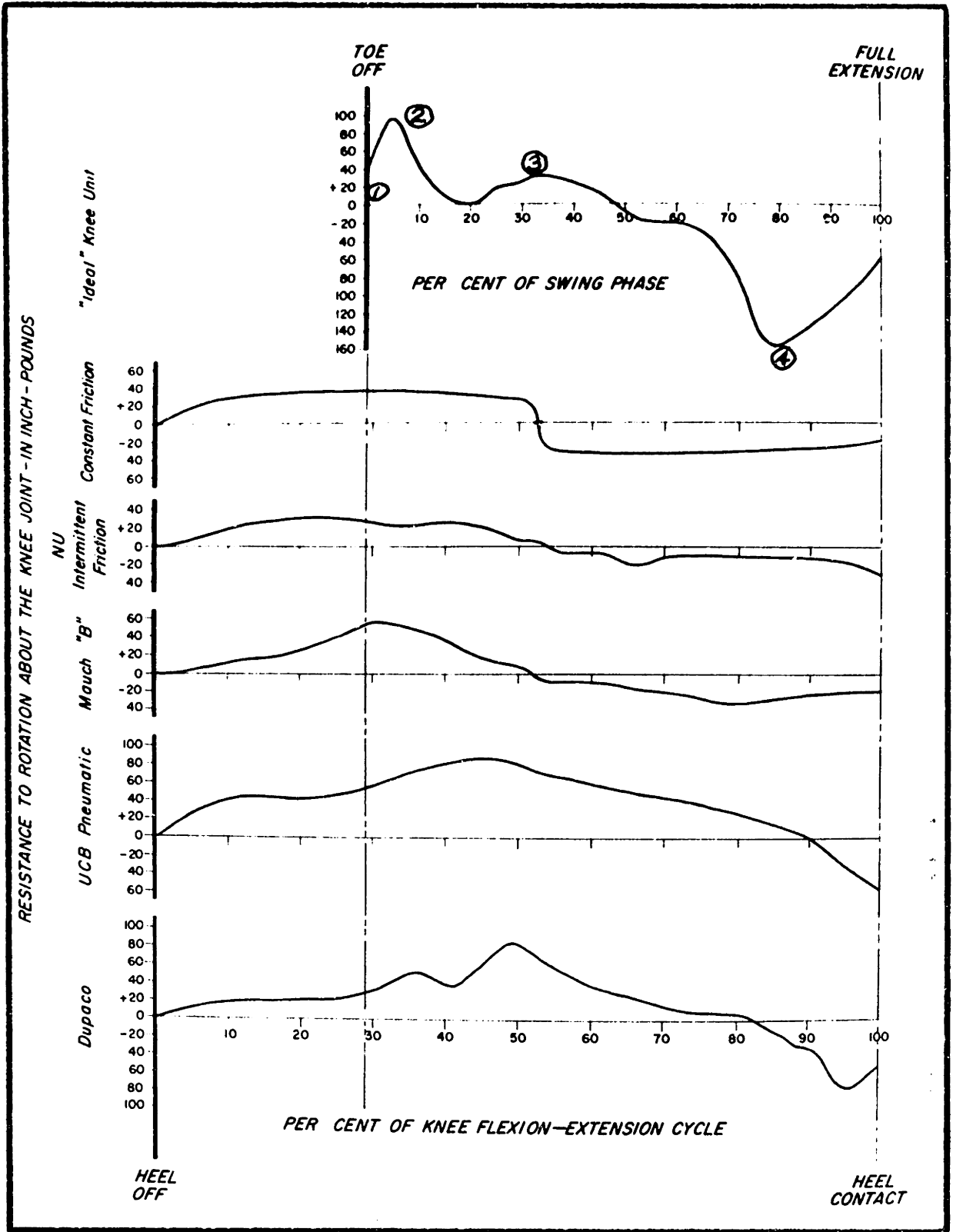

Figure 2-5 SCHEMATIC OF THE UCB PNEUMATIC SWING CONTROL UNIT



**Figure 2-6** KNEE-MOMENT PROFILES OF TYPICAL SWING CONTROL UNITS IN COMPARISON WITH AN "IDEAL" PROFILE (25)  
Note: ① ② ③ ④ refer to interphasic profile description in text.

1. Just prior to toe-off, the resistive torque should be low so that the initiation of knee flexion does not require large extension moments at the hip.
  2. Immediately after toe-off, the torque should remain low and in a direction opposite to the rotation of the knee. This damping moment should then increase as the heel lifts and reach a minimum at maximum heel rise.
  3. At this point, energy output from the mechanism is desirable to aid in initiating swing through.
  4. During swing through, an increasing, resistive torque is required to decelerate the rotating shank. This moment should peak just prior to heel strike.
- C. As cadence increases, the moments should be proportional to the square of the cadence.
- D. The mechanism must be tuned to the amputee and prosthesis, i.e., the mass distribution of the dynamic system establishes the needed torques.

### Stance Control

As was stated earlier, the primary purpose of stance control is to prevent buckling of the knee when the prosthesis is bearing the amputee's weight. The most popular way to achieve this stability is to

align the limb so that the center of rotation of the knee is dorsal to the load line; see Figure 2-7. This alignment applies a hyperextension moment to the hinge locking it against the stops. Multiaxial joints have been designed to accomplish stability in the same manner; see Figure 2-8. The main disadvantage of such devices is their inability to lock if the knee is partially flexed. In some contingent situations, this condition can be hazardous.

Another common method of stance control utilizes weight-bearing locks. When a compressive load is applied across the knee, a braking mechanism is engaged. Figure 2-9 is a functional schematic of the archetype. Variations of this control scheme include mechanisms engaged or disengaged by heel contact, toe contact, ankle angle, etc.

Still another system involves the hydraulic, swing-control devices. By simply stopping or severely restricting the flow from one side of the cylinder to the other, an effective lock is established.

#### Knee Mechanism Summary

Staros<sup>(20)</sup> has presented an outline of the types of knee mechanisms. It is shown in Figure 2-10.

#### Voluntary Knee Mechanism Control

The devices discussed thus far are essentially "automatic". The amputee cannot voluntarily change the mechanism's behavior independent of other inputs. The algorithms for control are based on the series of events in the gait cycle. Human mobility, however, is not uniquely satisfied by ambulation on smooth level surfaces at a fixed speed. These

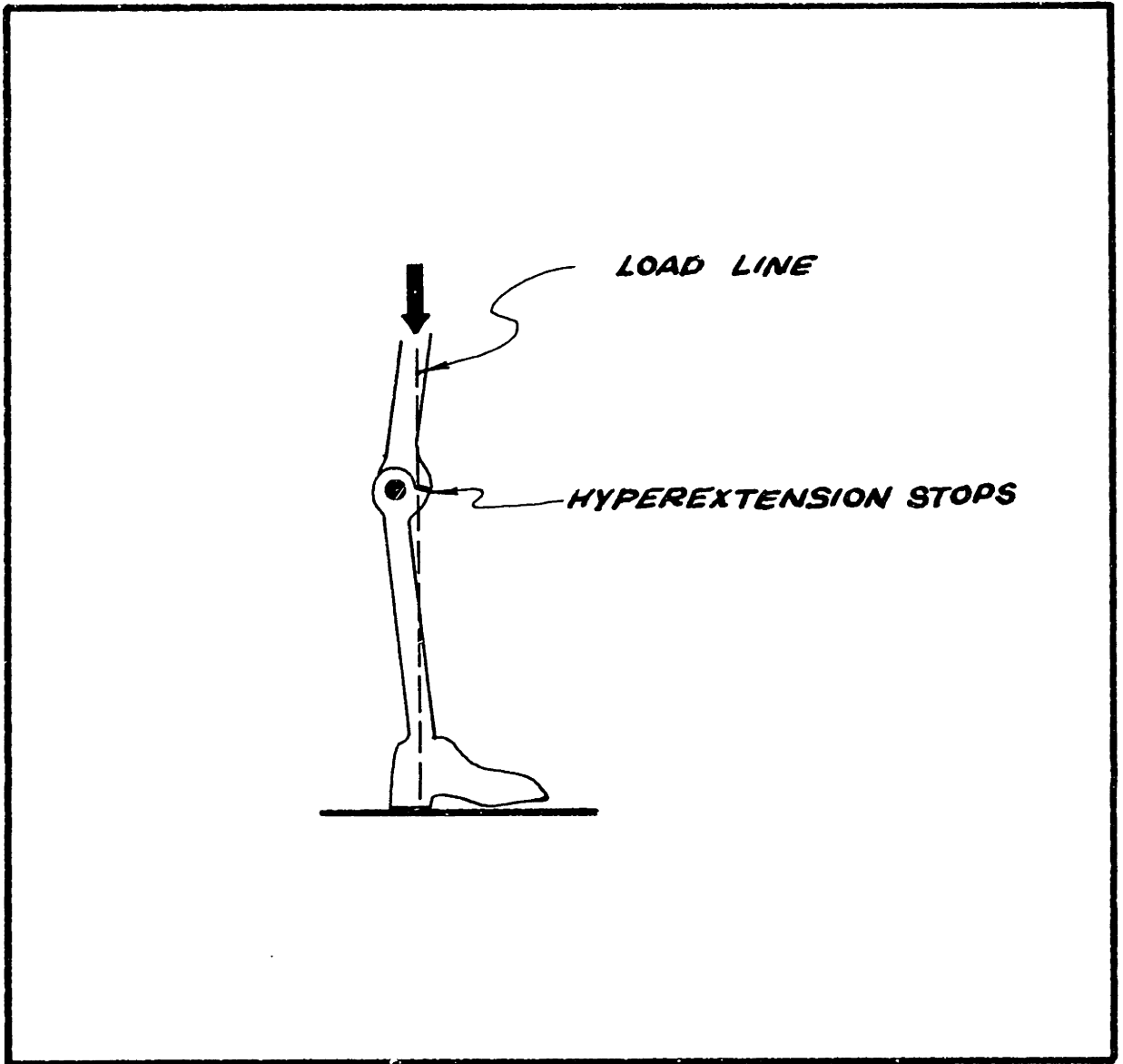

Figure 2-7 STANCE STABILITY RESULTING FROM ALIGNMENT AND HYPEREXTENSION STOPS

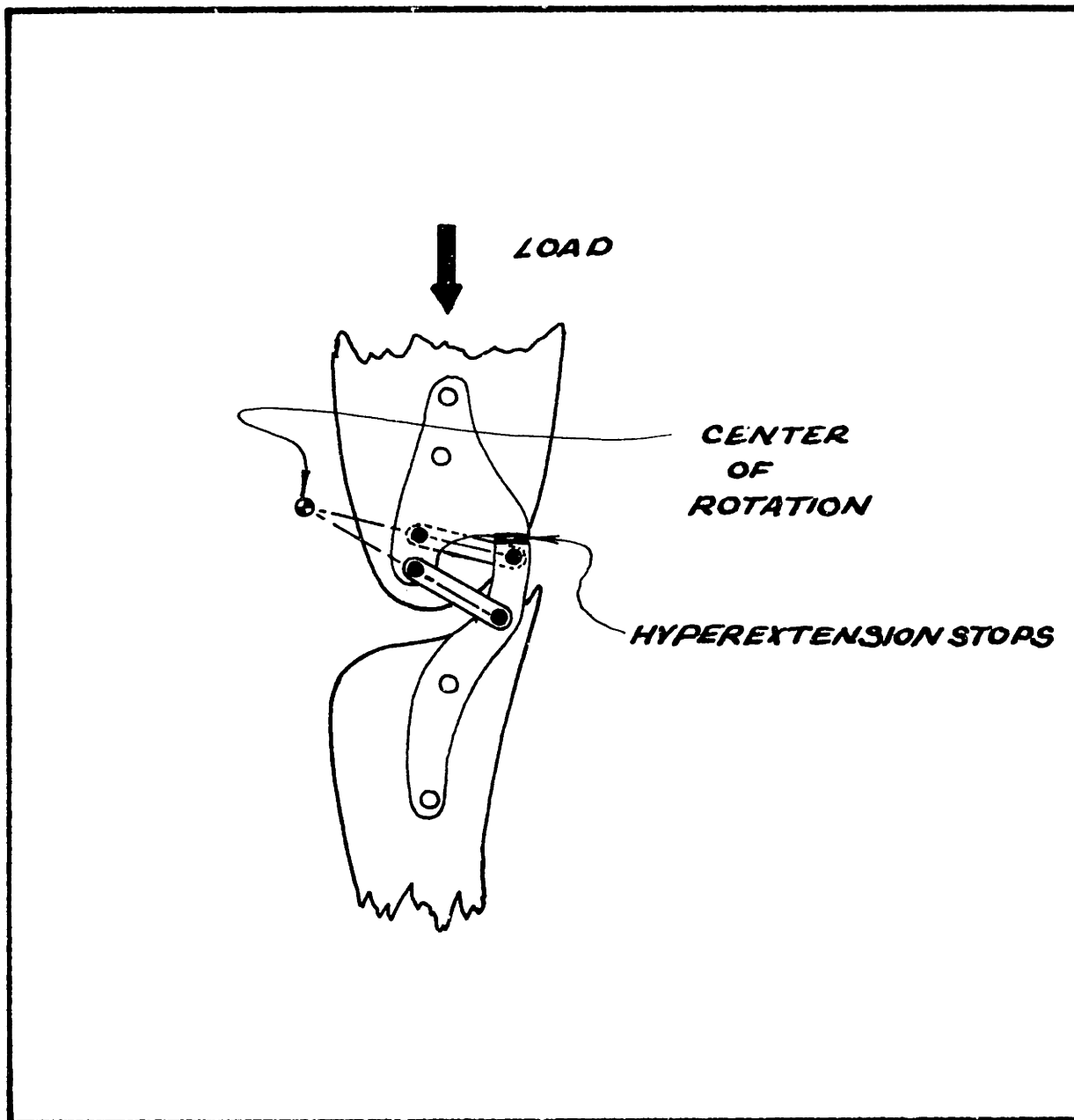

Figure 2-8 MULTIAXIS KNEE JOINT DESIGNED FOR ADDED STANCE STABILITY



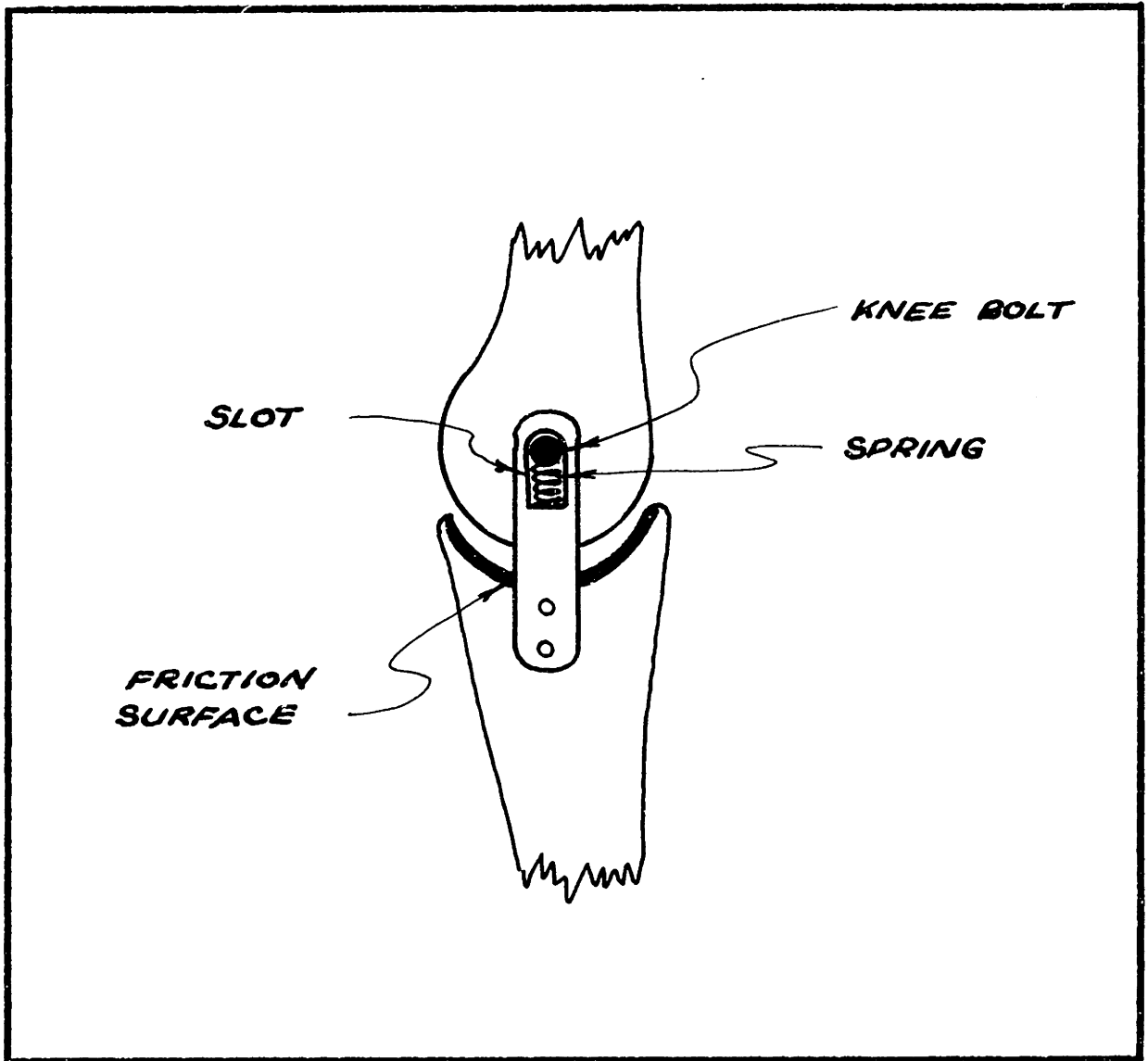

Figure 2-9 SCHEMATIC OF WEIGHT-BEARING KNEE LOCK  
IN THE UNLOCKED POSITION

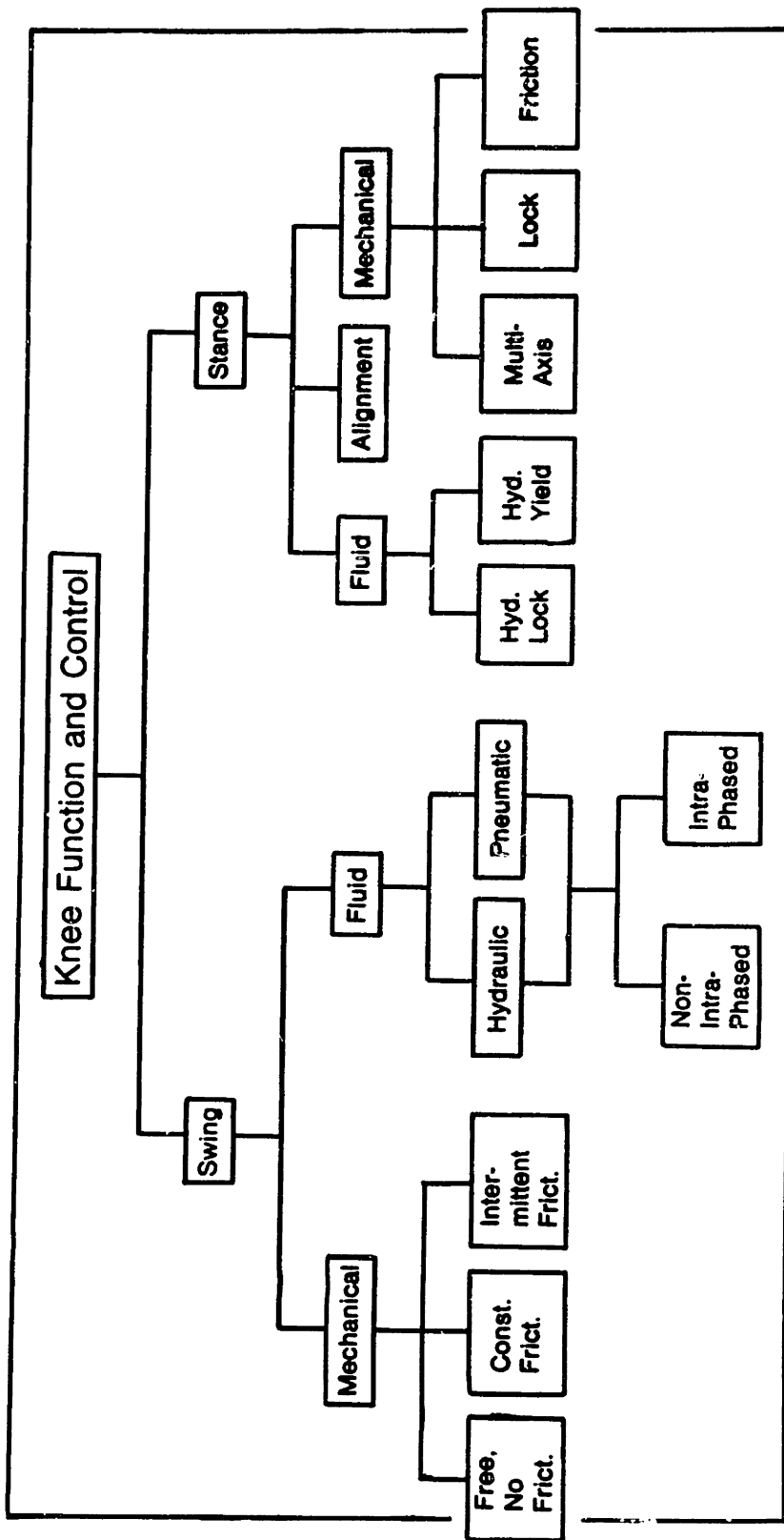

Figure 2-10 OUTLINE OF KNEE MECHANISM FUNCTION (20)

fully automatic systems can benefit little from man's ability to change modes of operation as the environment demands. Despite what seems to be an obvious need, relatively little work has been done on voluntary control. Some attention was given to "muscle bulge" switches for knee lock<sup>(7)</sup>. This idea was abandoned when it was determined that the brake being used was too unyielding and increased the probability of damage to the user's stump in stumbling situations. More recently, Horn<sup>(3)</sup> has tested an EMG-controlled flexion lock. Initial reports claim great advantages are afforded the user even though the degree of control is minimal. The amputee activates the lock from a muscle not normally used in walking. After the lock is turned on, extension is allowed and flexion is prohibited until full extension is reached. The brake is then automatically switched off.

#### EMG Control

The functional unit of a striated muscle is the motor unit. It consists of a single nerve cell and the muscle fibers to which it is connected. The nerve fiber acts as a transmission line from the spinal column to the muscle fibers. Each of the fibers in a motor unit are innervated by the same nerve cell; therefore, they contract nearly simultaneously. The number of fibers per unit varies from less than 20 in small precisely controllable muscles to more than 1000 in the gross skeletal muscles<sup>(8)</sup>. The units can contract and relax at rates up to 50 times per second<sup>(1)</sup>. The total force generated by a muscle is the result of two factors: the number of fibers that are "firing" and the

frequency of "firing". The second factor is a weak influence<sup>(24)</sup>, and increases in the muscle force are usually discussed in terms of a "recruitment" process wherein additional motor units are activated until the desired force is achieved.

As a byproduct of fiber contractions, a very complex electrical current flow exists in the muscle. The potentials associated with these currents are not difficult to detect with electrodes placed in the muscle or placed outside the skin near the muscle. These electromyographic (EMG) signals can be processed to yield an electrical signal roughly proportional to the isometric muscle force. The surface EMG levels are in the millivolt range. These signals have a spectrum that peaks near 20 cps and is very weak above 1000 cps<sup>(24)</sup>.

Electromyographic signals are now being used for control of prosthetic and orthotic devices. The raw EMG signals can be conditioned in many ways to yield a smooth command signal. Some examples follow:

1. Time average of the rectified signal.
2. Time average of the number of zero crossings.
3. Time average of the number of slope reversals.
4. A pulse train whose frequency is controlled by 1,2, or 3.
5. Threshold or discrete state signals that are controlled by 1,2,3, or 4.

The main thrust of the effort to use EMG signals for control has been directed toward improvements in upper extremity prosthetics.

Several EMG activated artificial hands have been produced<sup>(19)</sup>. The "Boston Arm"<sup>(9)</sup> has demonstrated the value of EMG for proportional control. Elbow joints of orthotic devices have been controlled in both on-off and proportional modes<sup>(2)</sup>. Wirta and Taylor<sup>(26)</sup> have used statistical methods to establish pattern-recognition criteria for developing a control scheme for a multiaxial whole-arm prosthesis utilizing EMG signals from 10 muscle sites. In research in progress at The Massachusetts Institute of Technology, a generalized analytical treatment of multiaxial, EMG control is being compared to experimental results<sup>(5)</sup>. Also, a superior EMG electrode and miniaturized preamplifier have been developed<sup>(6)</sup>.

Despite this virtual flurry of activity around EMG and its use as a control signal, only one lower limb prosthesis utilizes it for control<sup>(3)</sup>. As mentioned earlier, this Electro-control Prosthesis employs EMG signals as a convenient electronic "button" activated by a muscle carefully selected as one not involved in locomotion. By contrast, it is the spirit of this project to aim toward a more complete "symbiotic, synergistic relationship"<sup>(10)</sup> between the man and his artificial limb.

If a closed, conclusive argument could be presented showing quantitative increases in mobility and satisfaction resulting from a particular knee mechanism and EMG control scheme, the man-interactive simulator system discussed in this thesis would be unnecessary. The study has only begun, and the arguments are speculative, but there seems to be reason for optimism. If one assumes that the state-of-the-art technologies

will some day be applied to prostheses, control schemes can involve memory and extensive calculation involving the dynamic state of the man-limb system. The force inputs from the amputee to the limb, as well as assorted volitional and reflexive instructions, are available through EMG signals. It is therefore much more difficult to argue that EMG control will not be successful than to advocate its use. In short, EMG signals are a measurable indication of the intent or desire of the amputee and are, therefore, valuable as control information.

### Chapter 3

#### SELECTION AND PRELIMINARY EVALUATION

#### OF A KNEE TORQUE CONTROLLER

The most critical element in the simulator system is the torque controller for the knee joint of the prosthesis. In order to interface with analog or digital models, this device must provide proportional output torque in response to electrical inputs. It must also be lightweight (preferably less than 5 pounds) and compatible with the geometry of an A/K prosthesis. The required performance limits can not be defined precisely, but if the human knee is chosen as the epitome of the needed mechanism, the specifications are stringent. For example, consider the stall torque (maximum static torque) and the slewing rate (maximum no-load velocity) of the normal knee. A simple experiment with a stop watch shows that more than two 90° flexion-extension cycles per second can be accomplished without difficulty, thus yielding a slewing rate of  $2\pi$  radians per second. A deep knee bend on one leg requires knee moments in excess of 1000 inch pounds. These specifications are prohibitive for small, lightweight actuators, especially when both passive (power absorber) and active (power generator) operation is desired. The best approximation to the optimum device was found to be an electro-hydraulic servo.

Many other types of controllers were considered, but none approached the power density and controllability of the electro-hydraulic

actuator. Since such systems are used in military and space vehicles, they are the product of extensive research and are highly developed. Their only disadvantage in this application is that hydraulic lines must be provided between the moving amputee and a stationary pump. This requirement does not appear to be prohibitive for a feasibility study.

Figure 3-1 provides a basic explanation of the manner in which a flow control servo system can be used as a knee torque actuator. Negative force feedback is provided so that the control signal to the servo valve represents the difference between the input and the current state of the system. The valve closes only when the input command signal has been cancelled by the load cell output, i.e. when output equals input.

An experimental limb and actuator were assembled prior to beginning the final system design. Tests performed with this first prosthesis showed the electro-hydraulic system to be a reasonable solution and provided experience which influenced several practical aspects of the second-generation limb design.

For convenience, since only basic walking tests were to be conducted, the leg was fitted to the fully flexed knee of the author. See Figure 3-2. The socket and limb was fabricated by Mr. Michael Amrich, Prosthetist at the Liberty Mutual Rehabilitation Center in Boston. The knee joint and shank were made from orthotic knee brace parts. The knee



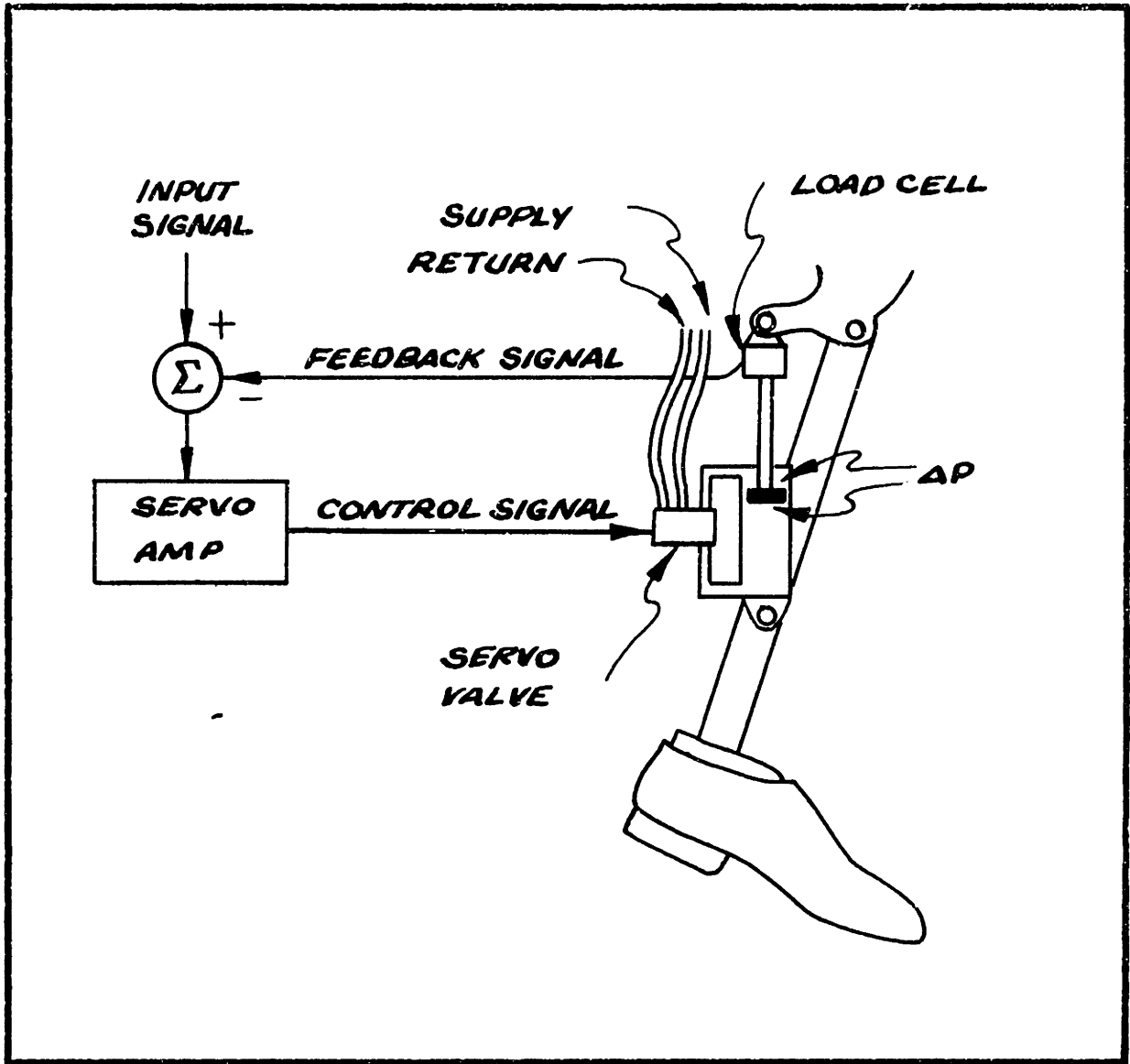

Figure 3-1 SERVO ACTUATOR IN TORQUE CONTROL CONFIGURATION

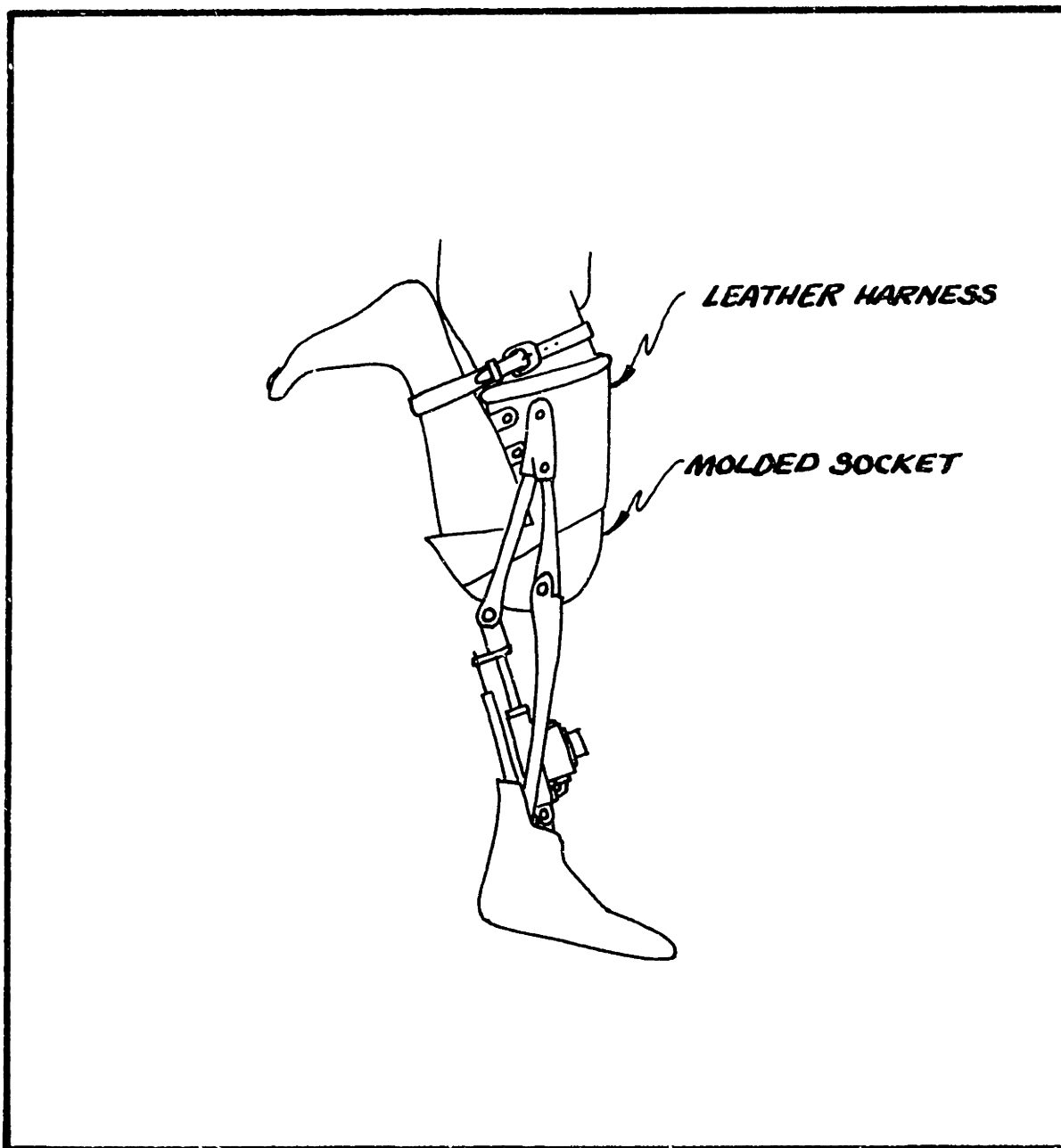

Figure 3-2 ILLUSTRATION OF THE EXPERIMENTAL PROSTHESIS FITTED TO NORMAL LIMB

hinge of the limb was aligned with the approximate center of rotation of the extended normal limb. A SACH (Solid Ankle Cushion Heel) foot was used.

Figure 3-3 shows the experimental prosthesis. The actuator was assembled largely from borrowed components. Its performance, therefore, was not optimum but adequate for a working mock-up. The author walked short distances with the prosthesis. Swing and stance control was provided by an assistant who varied the force feedback gain. The prosthesis was quite stable in stance and smooth during swing, but using it with one leg strapped in the fully flexed position proved too awkward and unnatural for meaningful EMG control experiments. Valuable experience, however, was obtained through tests conducted with the prosthesis on the test stand shown in Figure 3-3.

One of the first realizations was that nonlinear geometry is very troublesome. Figure 3-4 illustrates the drastically changing ratio between  $\Delta\theta$  of the knee and  $\Delta x$  of the cylinder. This change causes the feedback coefficients to be a function of the position of the knee. In the fully flexed position, for instance, force feedback gain became very large. In real, non-ideal systems, high feedback gains usually cause dynamic instabilities manifested by uncontrolled oscillations. In this case, the tendency for instability increased as the knee joint was flexed. To stabilize the system, an approximate reciprocal non-linearity was used in the feedback loop. It was necessary to reduce the torque feedback gain ( $K_t$ ) as  $\theta$  increased. The decreasing  $K_t$

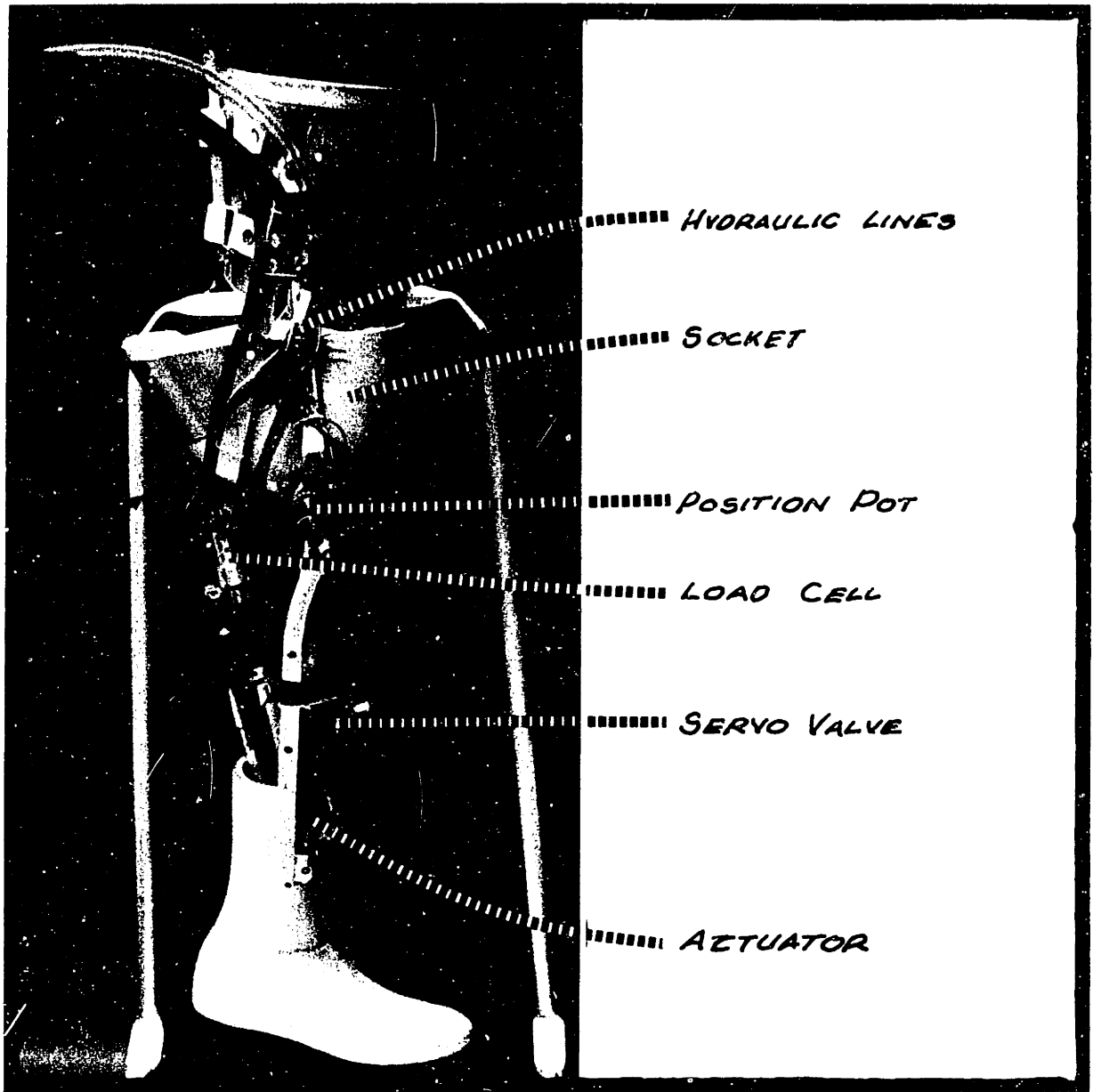

Figure 3-3 EXPERIMENTAL PROSTHESIS

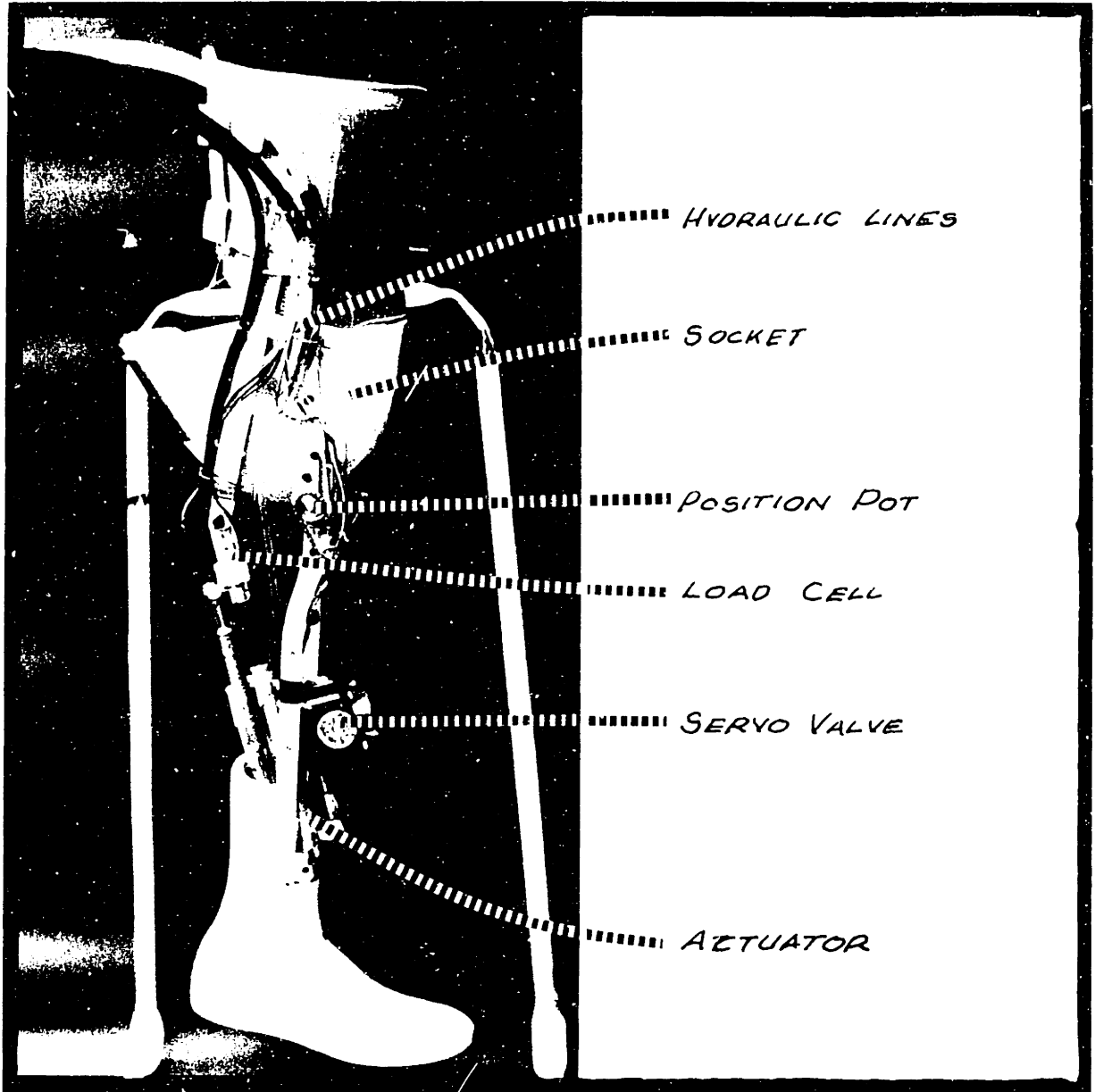

Figure 3-3 EXPERIMENTAL PROSTHESIS

INTENTIONAL DUPLICATE EXPOSURE

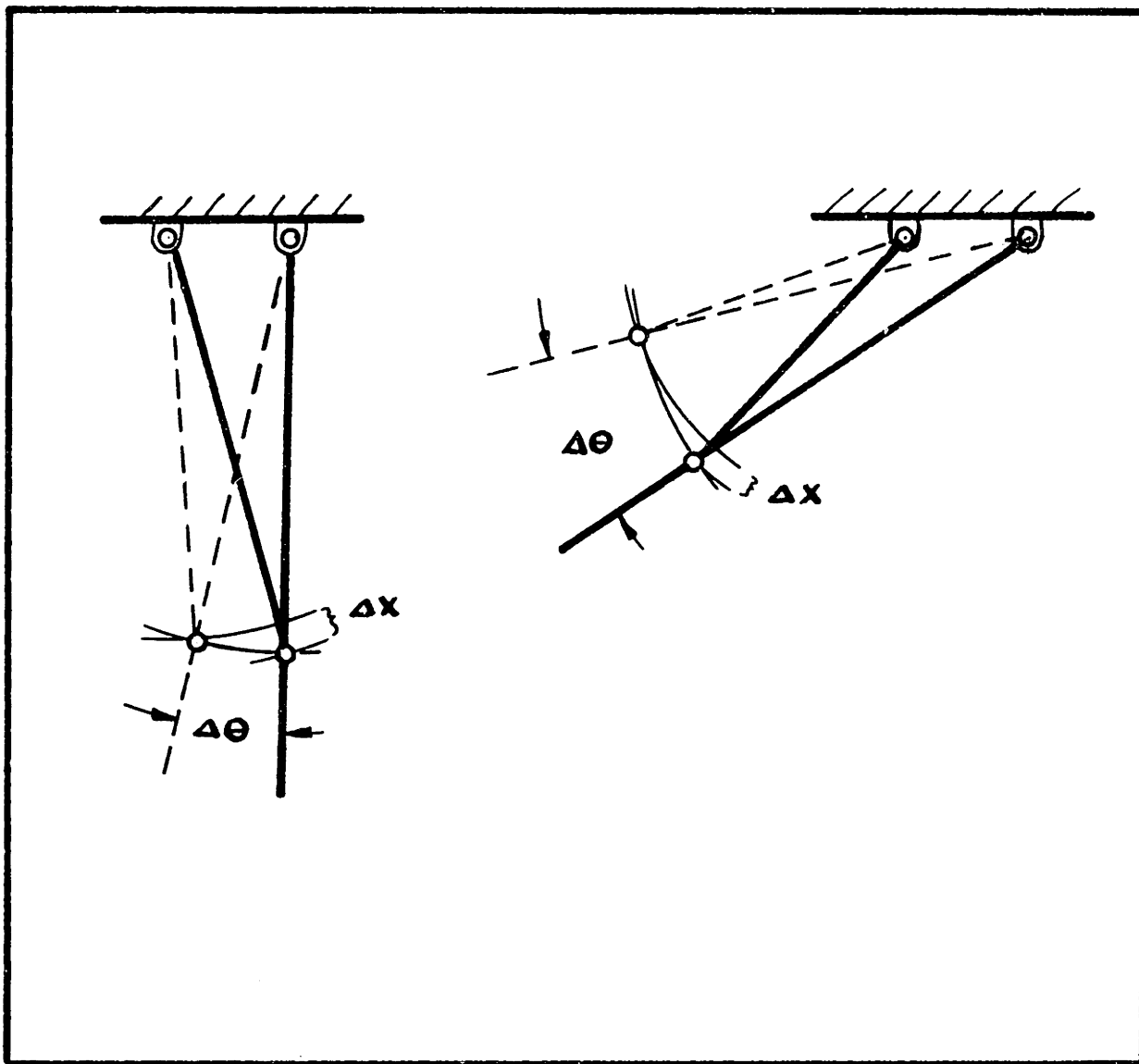

Figure 3-6 CHANGING RATIO OF  $\Delta x$  to  $\Delta\theta$

resulted from multiplication by a nonlinear function of  $\theta$  obtained from a special potentiometer arrangement. This point is mentioned only to emphasize that a single linear relationship between the actuator position and the knee position greatly simplifies control.

Second, it became obvious that the load cell requirements were unusual. When the knee is locked, the load cell can be subjected to loads approaching 1000 pounds. In the swing phase, however, it must provide an accurate feedback signal from force inputs as low as one pound. Also, it must exhibit very little hysteresis since an error in zero indication is equivalent to a bias torque command.

Figure 3-5 illustrates the load cell designed for the prototype. The nonlinear characteristic of the double diaphragm yielded the needed sensitivity variation, but this device was not designed to withstand the loads anticipated in the final simulator.

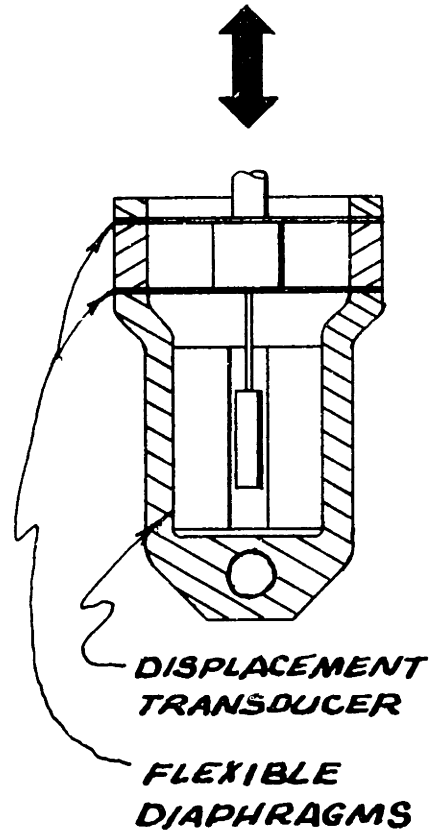
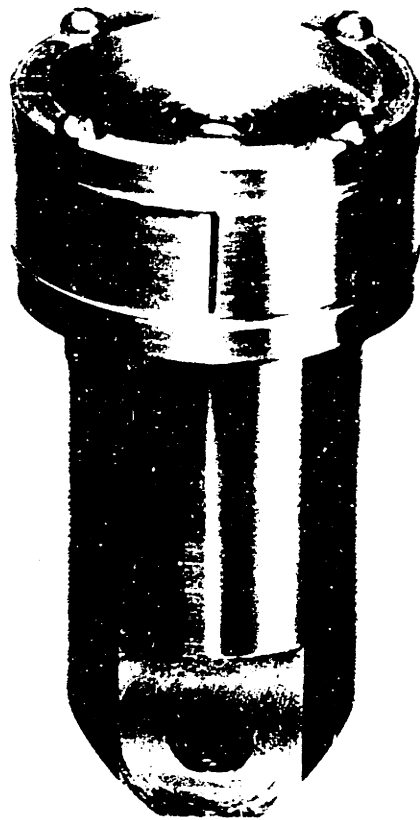

Figure 3-5 LOAD CELL FOR EXPERIMENTAL PROSTHESIS.  
Note: See Figure 3-3 for location in prosthesis.



## Chapter 4

### DESCRIPTION OF THE SIMULATOR SYSTEM

After the initial experiments had shown that an electro-hydraulic actuator is a suitable knee torque controller, a final prosthesis and support system was designed and constructed. The description of the apparatus will be presented in three basic divisions: the prosthesis itself, the hydraulic system, and the electrical system. An overall schematic is provided in Figure 4-1. The present installation site allows the amputee to move freely in a space approximately 30 feet by 8 feet.

#### The Prosthesis and Feedback Elements

Figure 4-2 shows the assembled prosthesis with overall dimensions. Figure 4-3 shows various positions including full flexion.

The device was designed to be compatible with modular prosthesis components. The top of the knee bracket fits a Staros-Gardner alignment coupling. A standard 1.625 inch diameter tubular shank attaches to the lower end. Symmetry was maintained so that the mechanism could be used on either the right or left side. The overall length allows using the device in prostheses having short shank lengths. Long stumps can be accommodated since the top of the knee bracket is less than 2 inches above the knee axis. One hundred and five degrees of flexion is provided. Flexion and extension stops are inside the hydraulic cylinder. The overall weight including hydraulic fluid, a tubular shank,

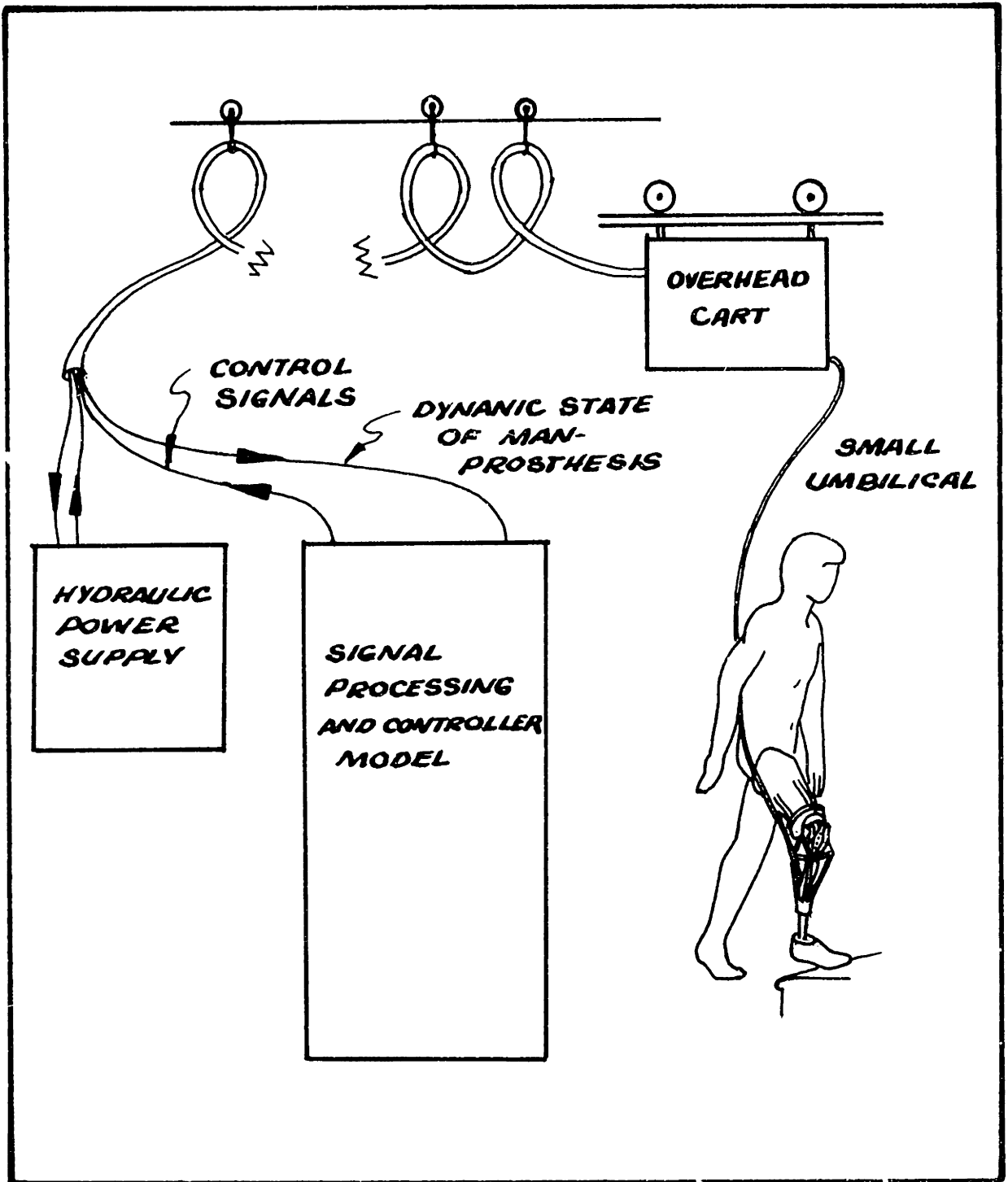

Figure 4-1 OVERALL SYSTEM SCHEMATIC

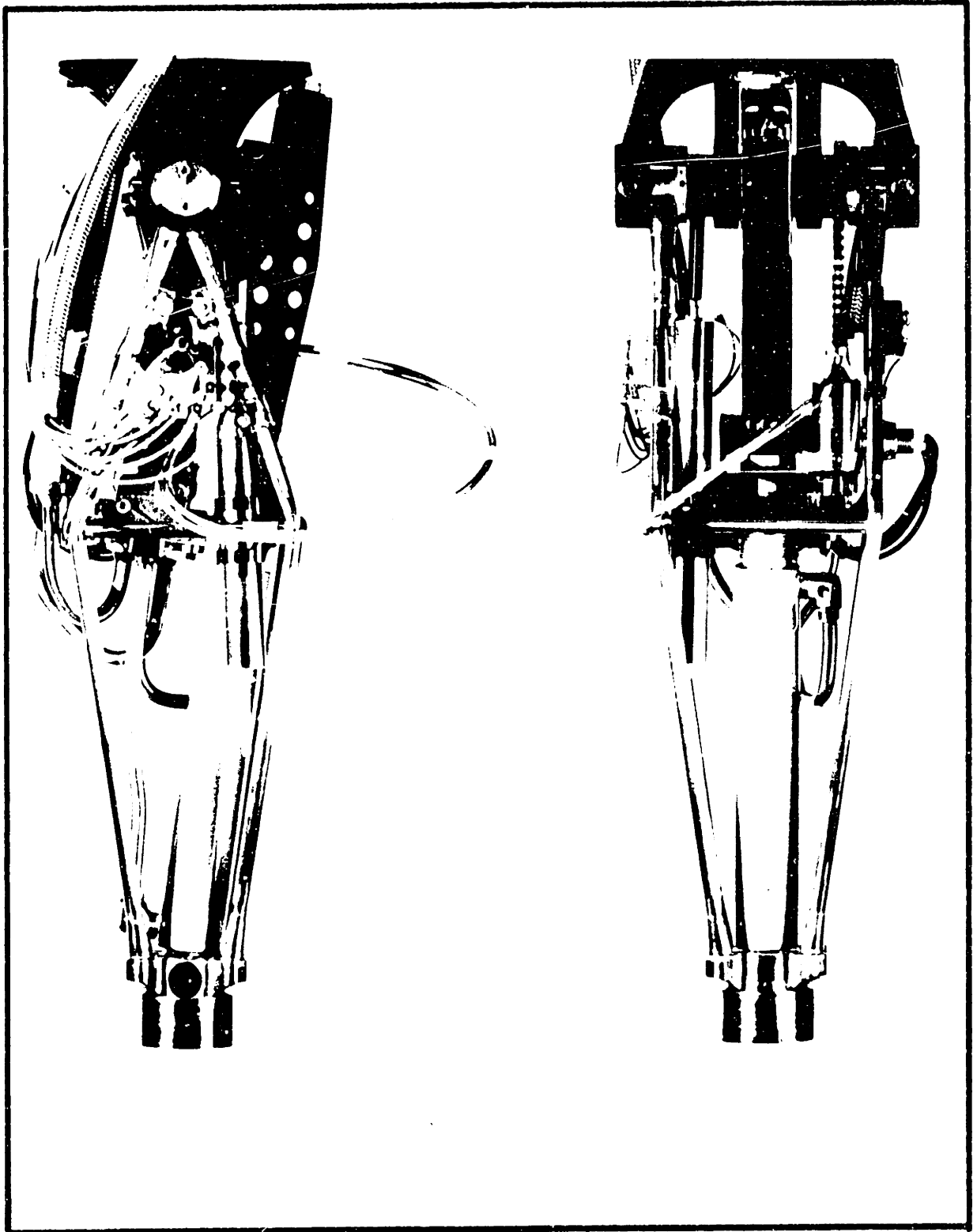

Figure 4-2(A) ASSEMBLED SIMULATOR SYSTEM PROSTHESIS

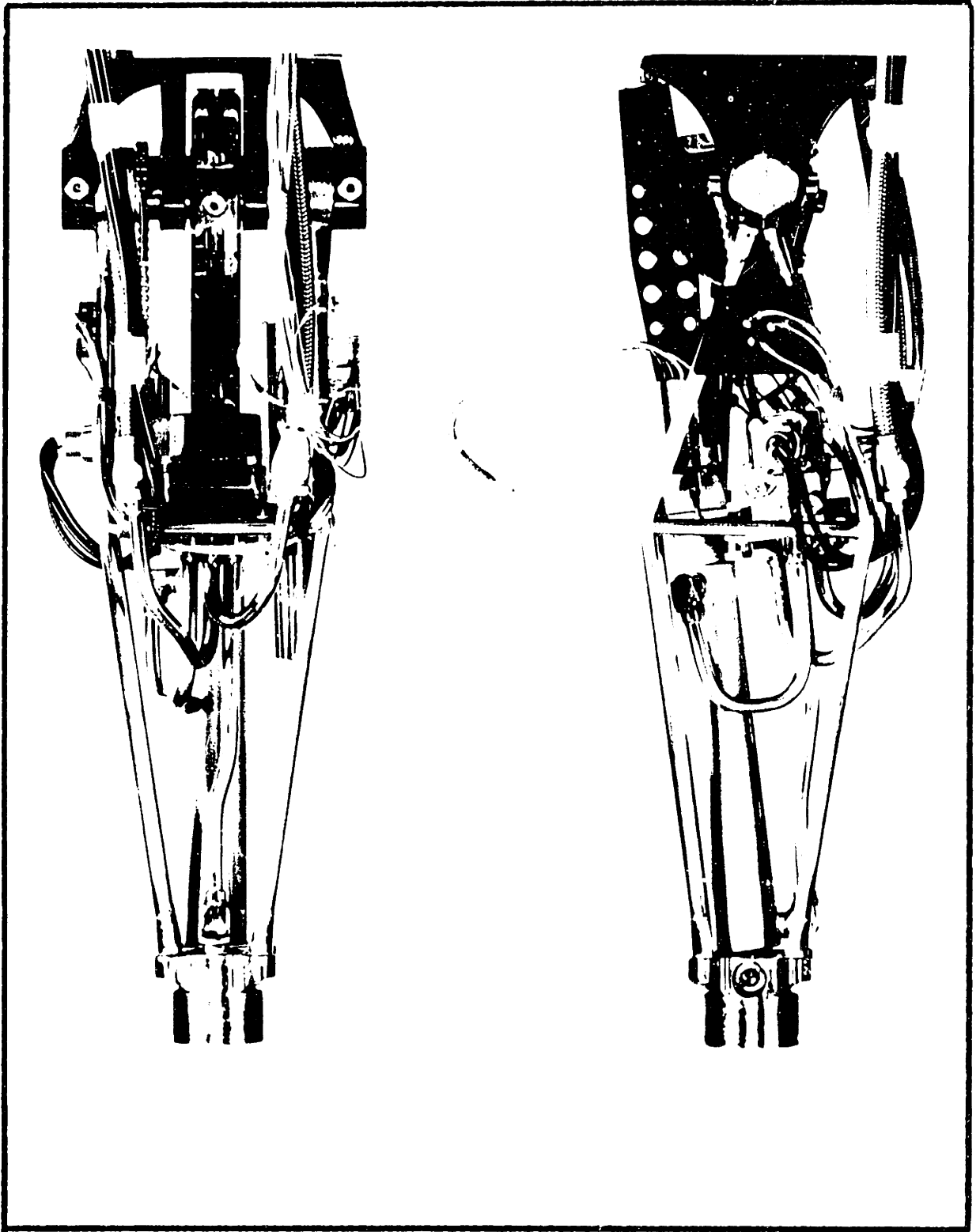

Figure 4-2(B) ASSEMBLED SIMULATOR SYSTEM PROSTHESIS

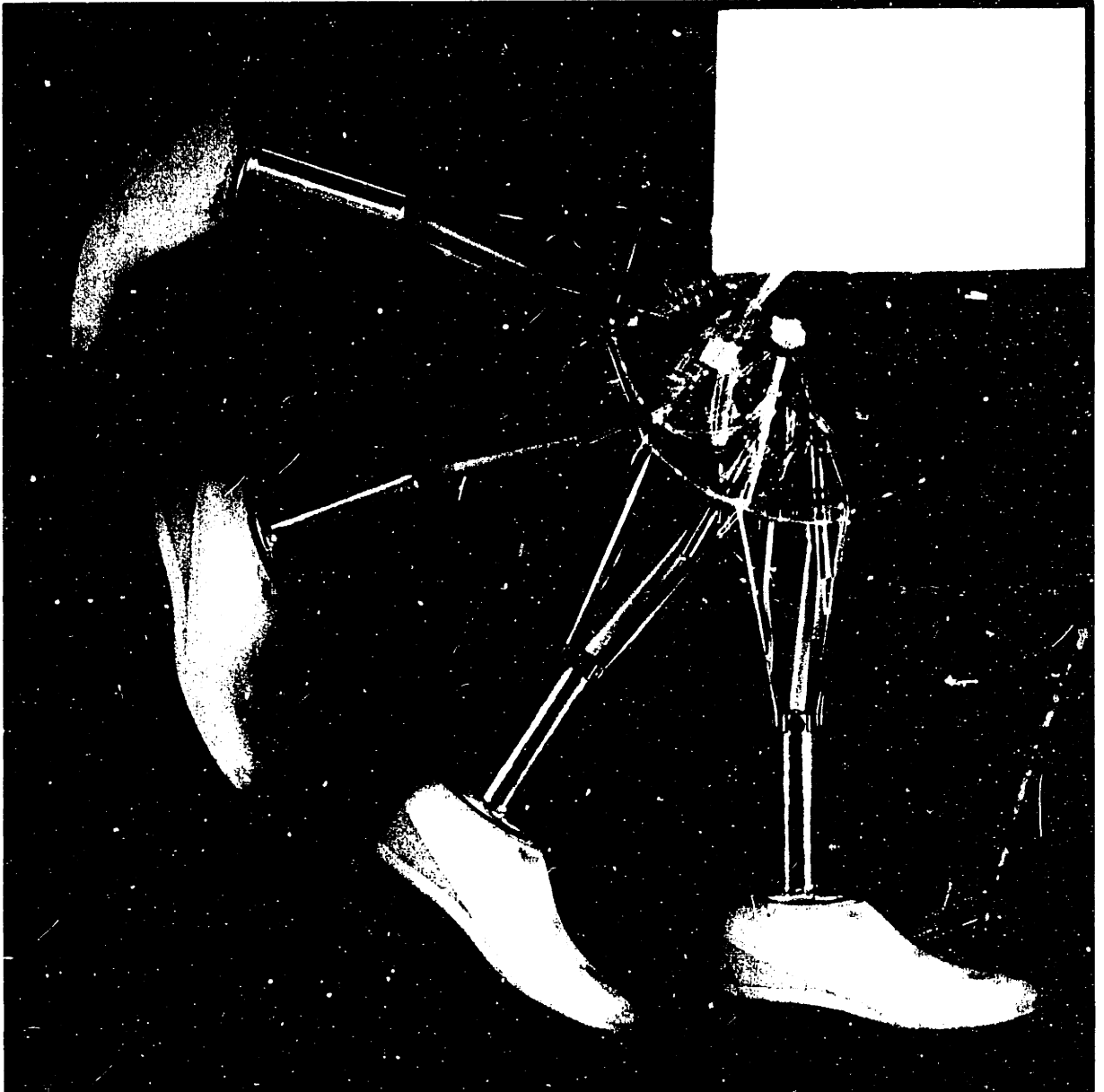
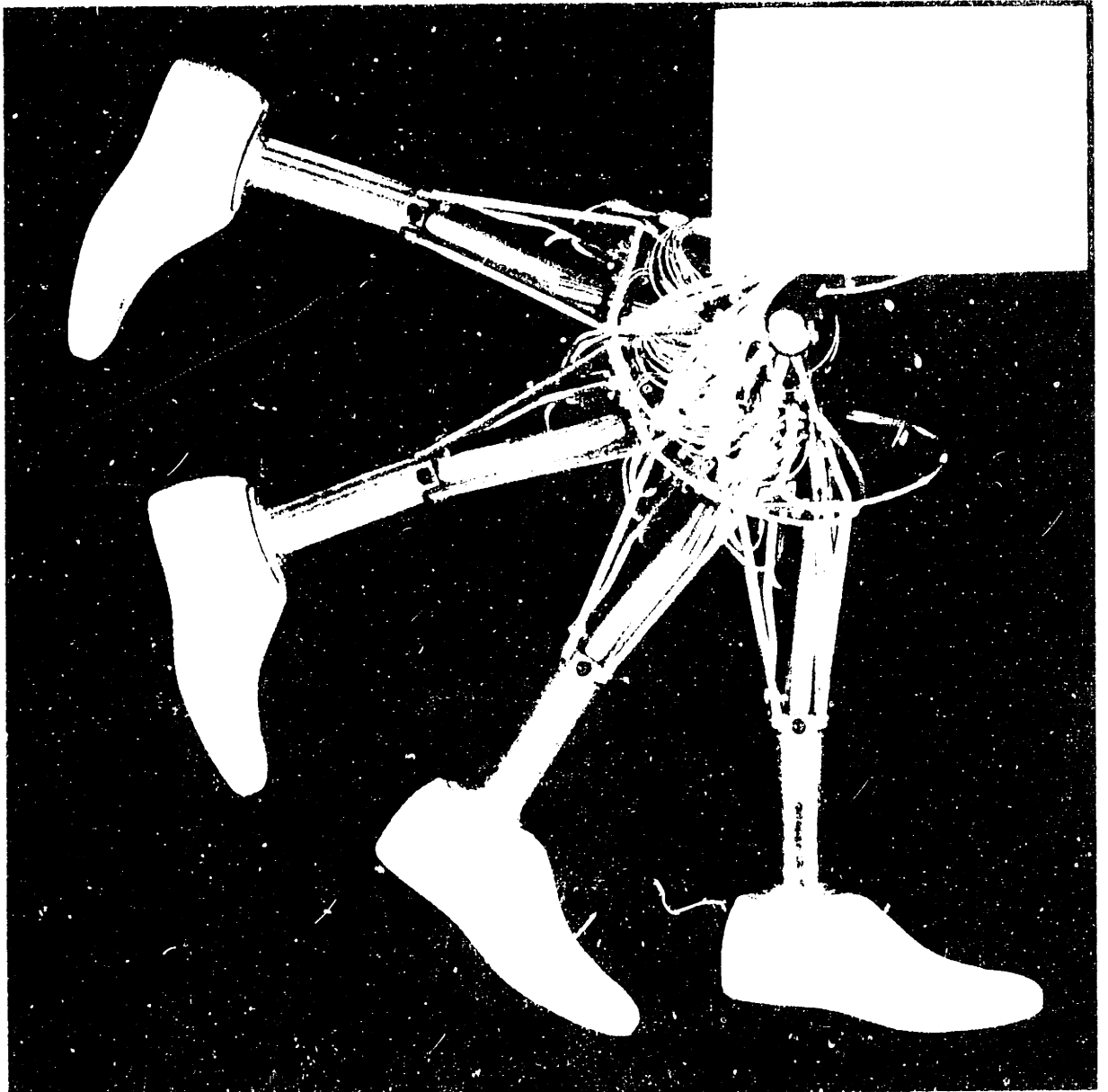

Figure 4-3 PROSTHETIC KNEE JOINT RANGE OF ROTATION



a SACH foot, and a shoe is approximately 6.5 pounds. The center of gravity is 10.5 inches below the knee axis.

Because of the intrinsic weight of the servo valve and cylinder, the remaining components had to be carefully designed for minimum weight. A lightweight frame was made of stainless steel tubing 1/4 inch in diameter with 0.025 inch walls; see Figure 4-4. The joints were silver brazed, achieving a frame weight of 11 ounces. A similar but cruder frame was compression tested on an Instron Machine. A load of 1200 lbf was required before plastic deformation occurred. The compressive spring constant was 22,500 lbf/inch.

The upper knee bracket was made of two pieces of 2024 aluminum. In Figure 4-5, it is shown with the knee shaft in position. The function of the bracket is to transmit the knee torques and axial loads from the shaft to the base of the socket.

The torque coupler is shown in Figure 4-6. Its purpose is to transform the linear motion of the actuator to rotation about the knee shaft without backlash. The cable system was chosen because of its high strength-to-weight ratio. A cable preload adjustment screw is located at the top of the compression strut. The knee shaft is shown in position to illustrate its coupling to the cable holder and cable drum. Black parts are made of aluminum; the others are of steel.

Space and weight requirements dictated unorthodox design and assembly of the manifold and cylinder unit. See Figure 4-7. A modified Clippard double-acting cylinder was used. The 3.0 inch stroke was

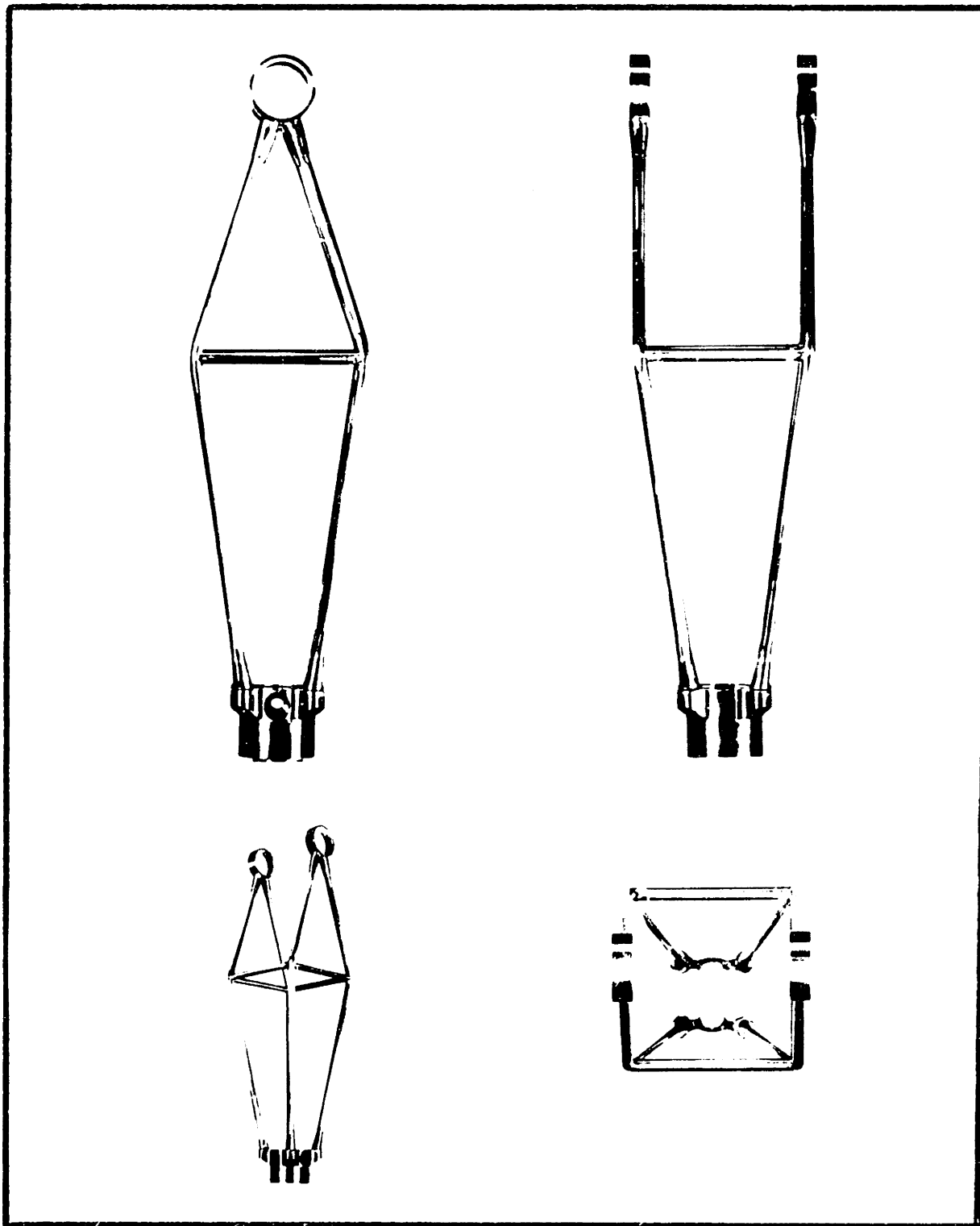

Figure 4-4 PROSTHESIS FRAME



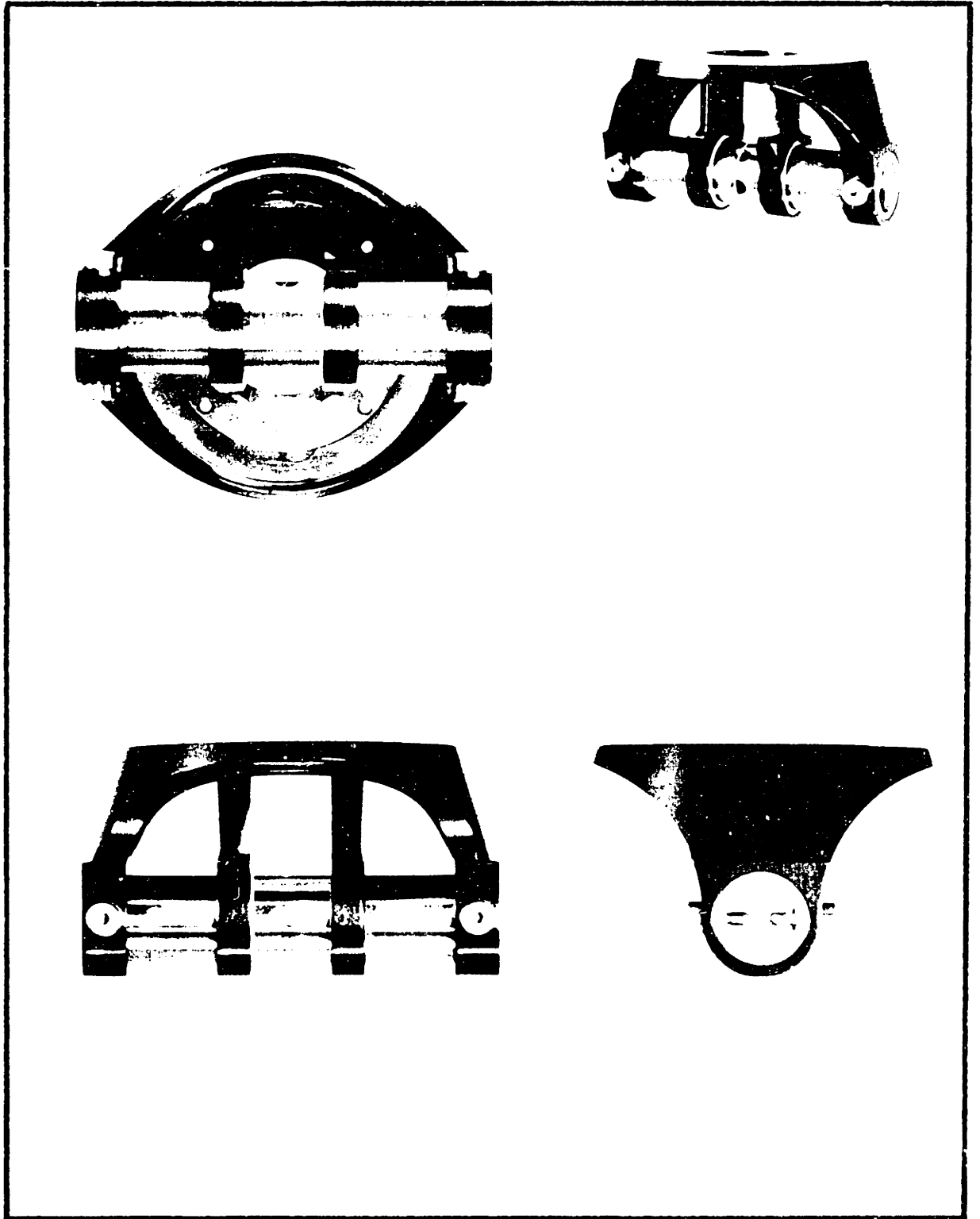

Figure 4-5 UPPER KNEE BRACKET

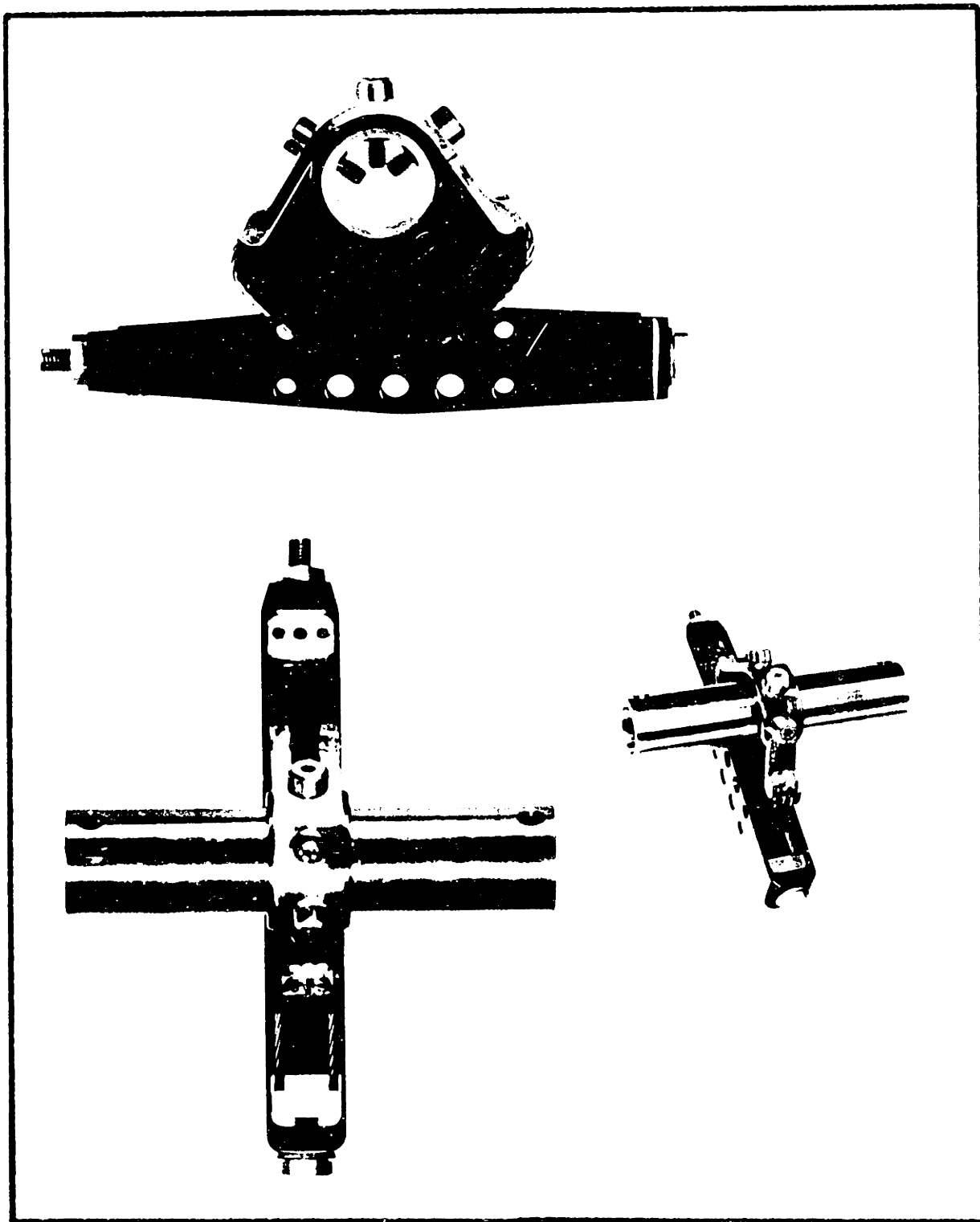

Figure 4-6 TORQUE COUPLER

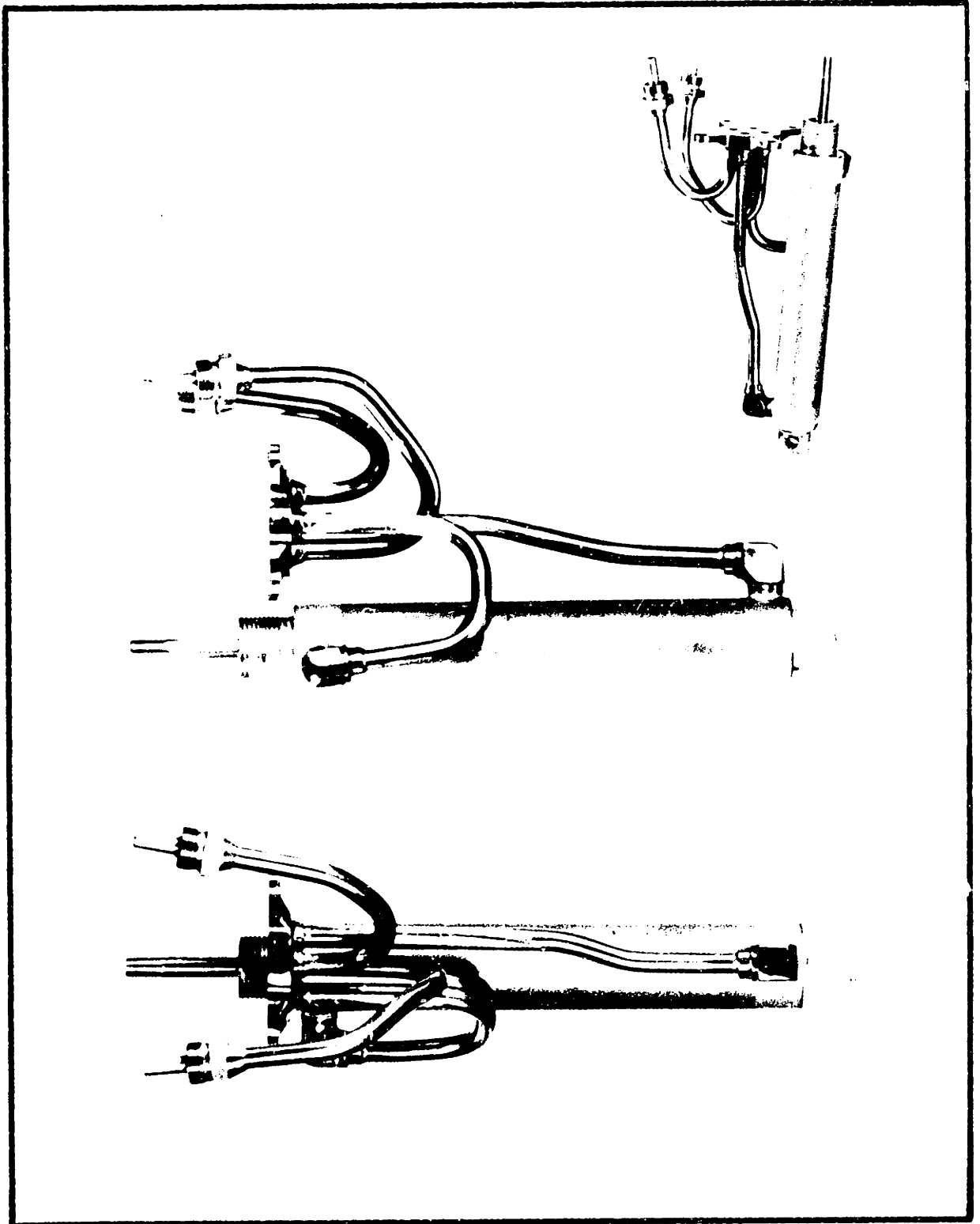

Figure 4-7 MANIFOLD AND CYLINDER UNIT

reduced to 2.875 inches by the addition of an extra shock washer on the piston rod. The front cylinder port was rotated by slightly shortening the cylinder so that the threaded end-piece would seal in the desired new position. The cylinder bore is 0.875 inches. The stainless steel manifold tubing has a 0.250 inch O.D. and .049 inch walls. The manifold plate is also stainless steel. Except for the 1/8 N.P.T. connections at each end of the cylinder, all tubing connections are silver brazed. This minimizes weight and volume but complicates disassembly.

The servo valve was manufactured by MOOG Inc. It is a two-stage, flow-control valve of the type commonly used in military and aerospace applications. The overall dimensions are shown in Figure 4-8.

The knee position potentiometer is operated by a chain drive as shown in Figure 4-9. Sprocket ratios were chosen so that full knee flexion represents the full range of the potentiometer. A spring was incorporated to prevent backlash.

Rotational velocity can be obtained by differentiation of the position signal; however, analog differentiation is very sensitive to input noise. Therefore, a velocity transducer was included to insure the availability of a "clean" velocity signal if it is needed. The transducer mounting and operation is illustrated in Figure 4-10.

The load cell was designed to be very sensitive to small forces and insensitive to large overloads. Figure 4-11 illustrates how the forces are transferred from flexures to mechanical stops as the load increases. The flexures can be changed to provide the desired

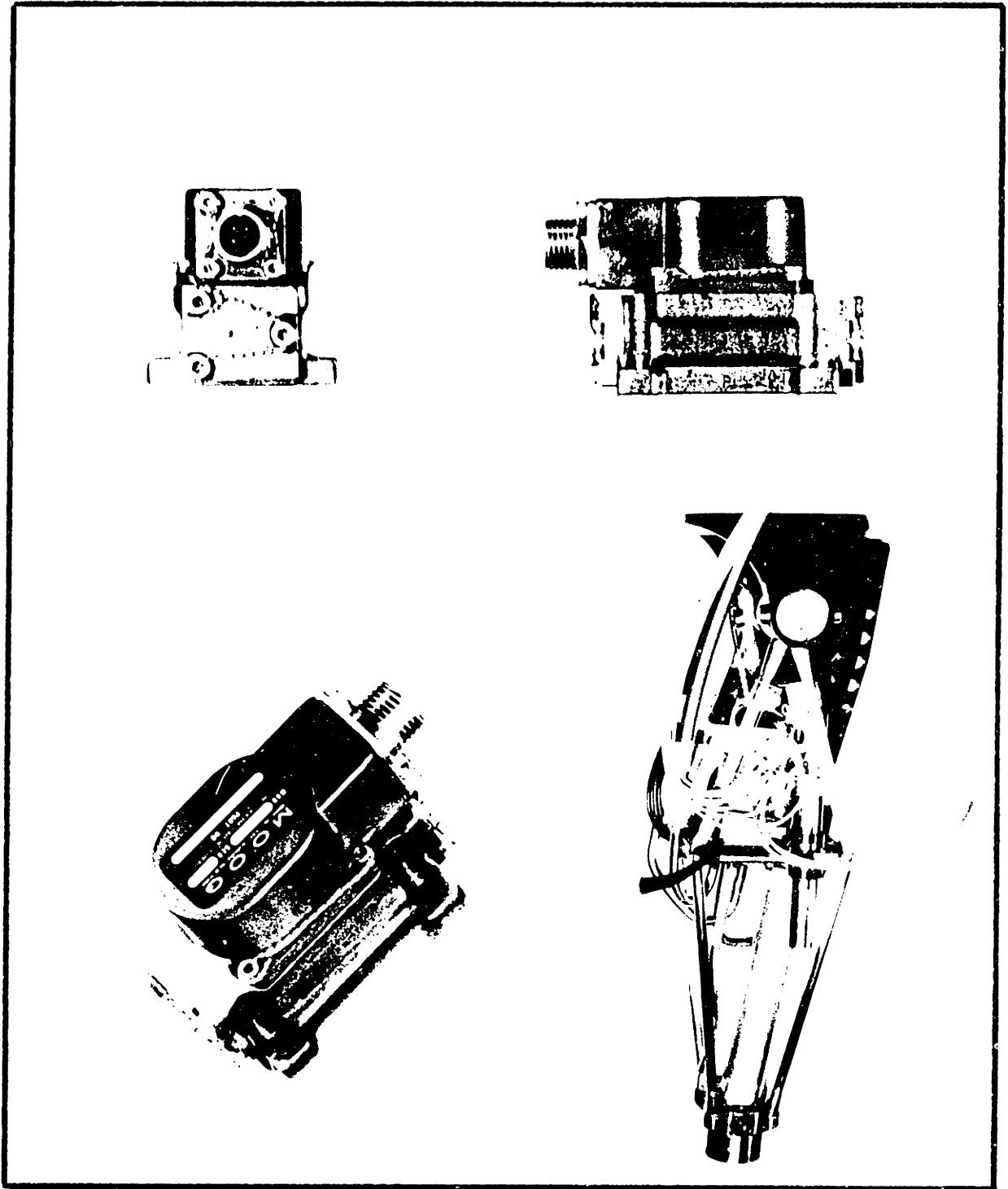

Figure 4-8 SERVO VALVE

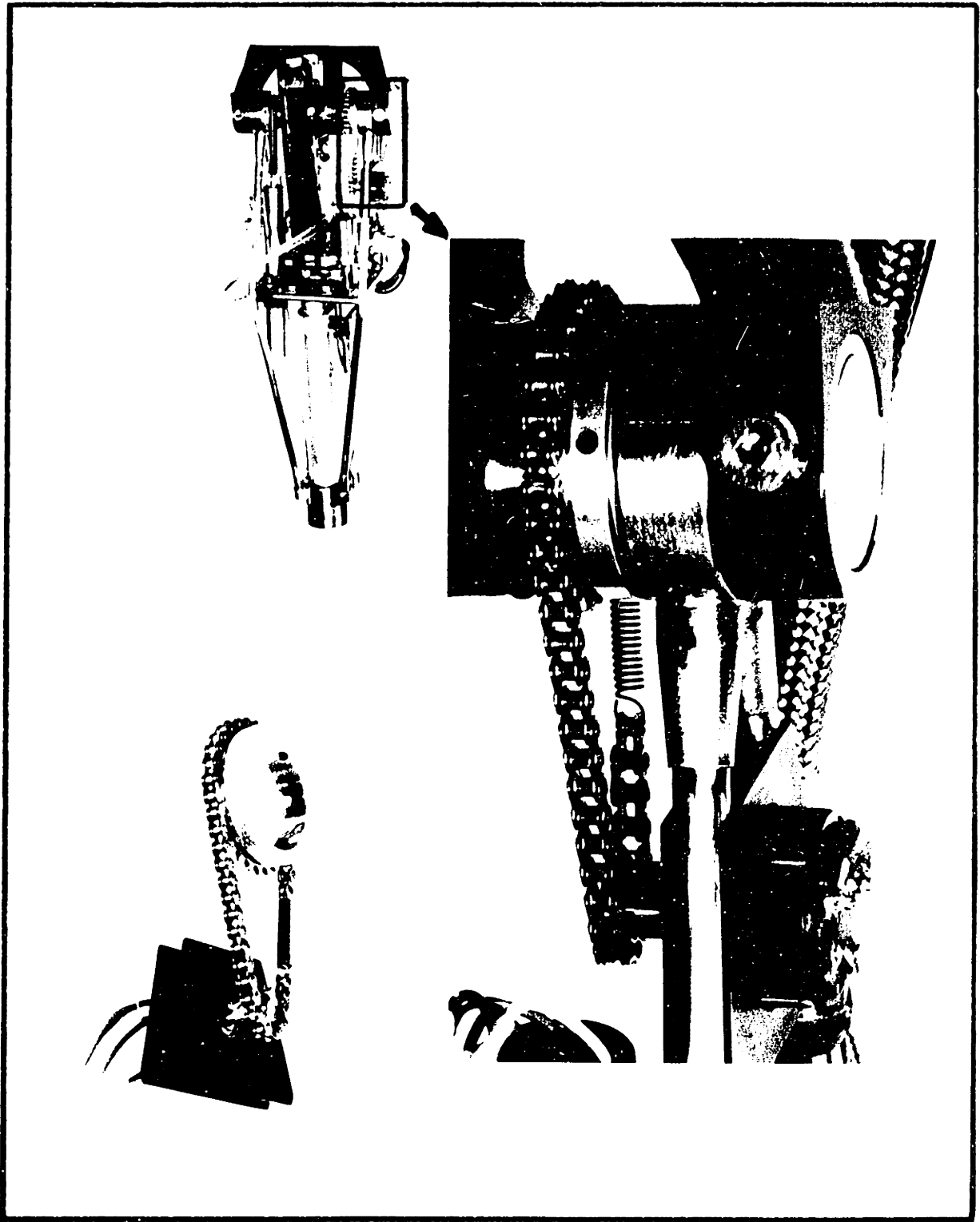

Figure 4-9 KNEE POSITION TRANSDUCER

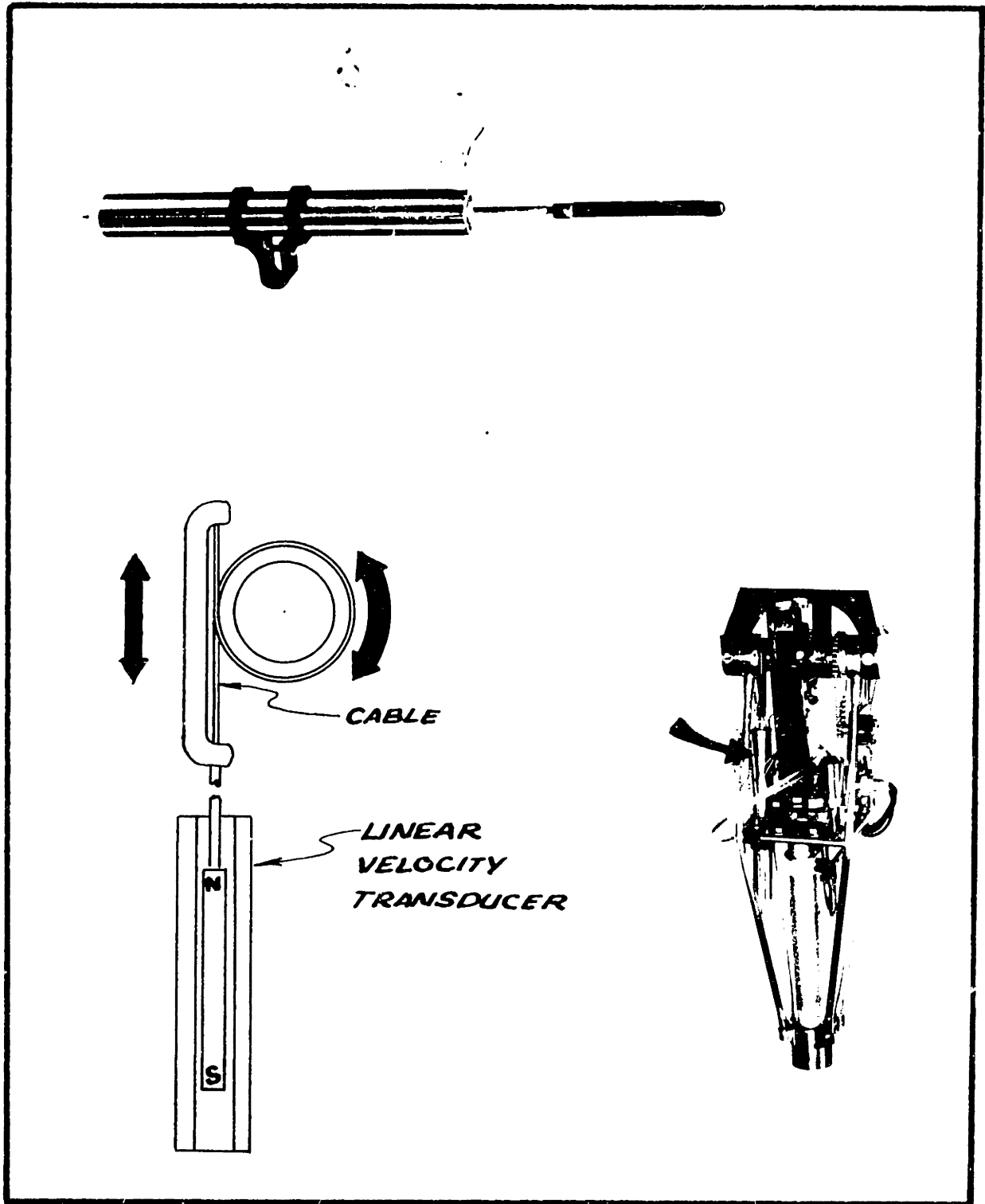

Figure 4-10 VELOCITY TRANSDUCER

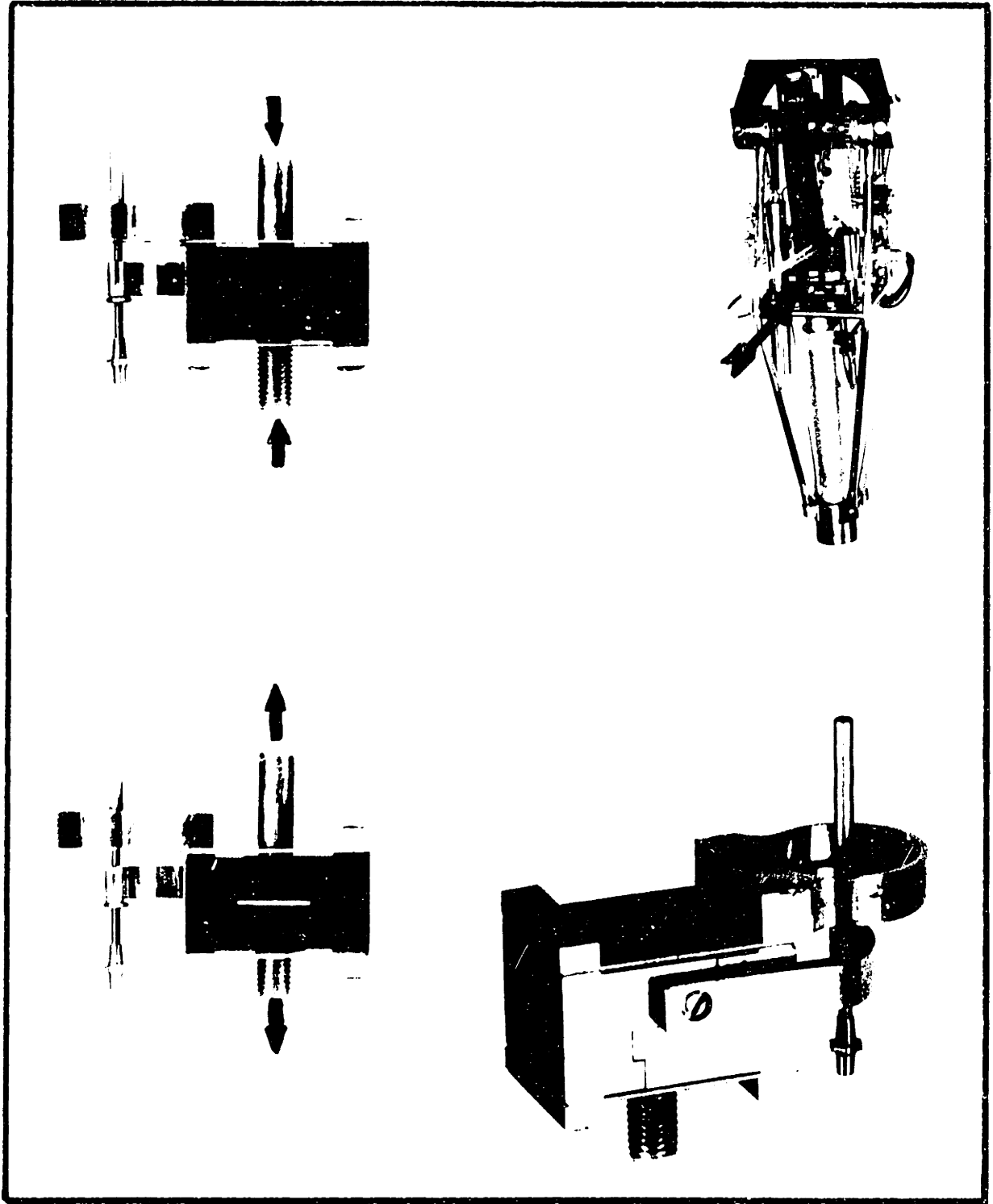

Figure 4-11 LOAD CELL



sensitivity and limit level. Deflection is sensed by a displacement transducer having a sensitivity of 90 volts/inch. This provides signal levels of approximately  $\pm 1$  volt at the stop limits. The output impedance of the displacement transducer is sufficiently low so that no additional amplification is needed before the transmission of its output through the umbilical lines.

### The Hydraulic System

A hydraulic power supply was provided so that the simulator system would not have to be located near existing hydraulic facilities. The hydraulic pump has a maximum capacity of 3 gallons per minute (11.4 cubic inches/second) at 1000 psi. The pump relief valve is adjustable to allow operation at lower pressures. A twenty gallon reservoir minimizes oil temperature rise. An acoustic enclosure around the hydraulic power supply reduces the noise level so that normal conversation is not impaired. See Figure 4-12.

A flexible pressure hose connects the pump to the overhead cart. To allow its extension and compression as the cart moves, the hose is coiled and suspended from a cable as shown in Figure 4-13.

Figure 4-14 is a photograph of the hydraulic components on the overhead cart. The 10 micron filter traps particles that might harm the servo valve. The accumulator reduces the effect of pressure drop in the supply line from the pump. An electrically operated spool valve is provided for use as a safety device. This "abort" valve can operate in either configuration shown in Figure 4-15. The valve can be operated

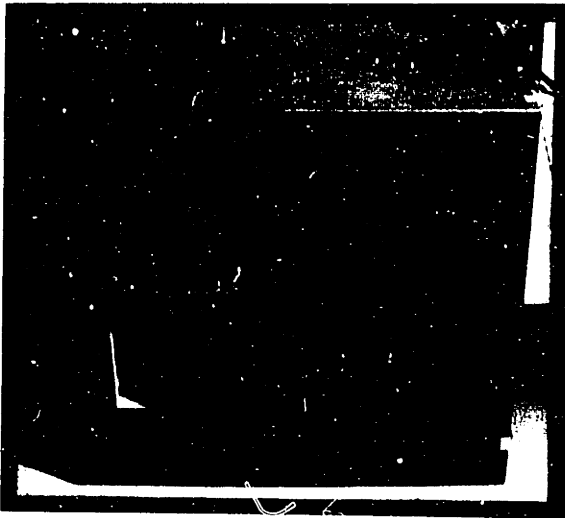

Figure 4-12 ACOUSTIC ENCLOSURE FOR HYDRAULIC POWER SUPPLY

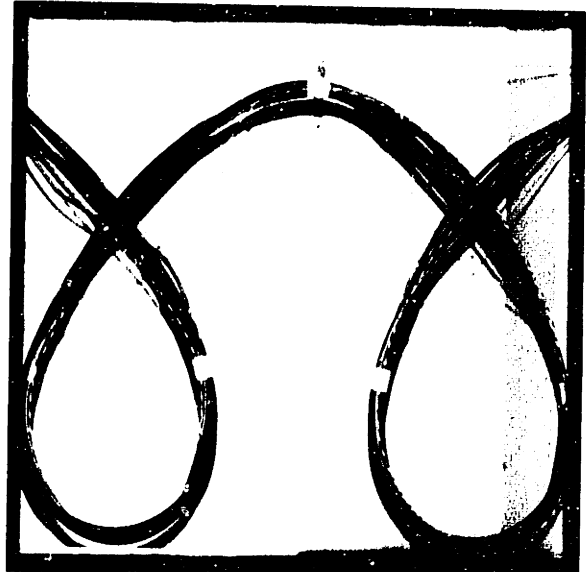

Figure 4-13 UMBILICAL LINE TO OVERHEAD CART

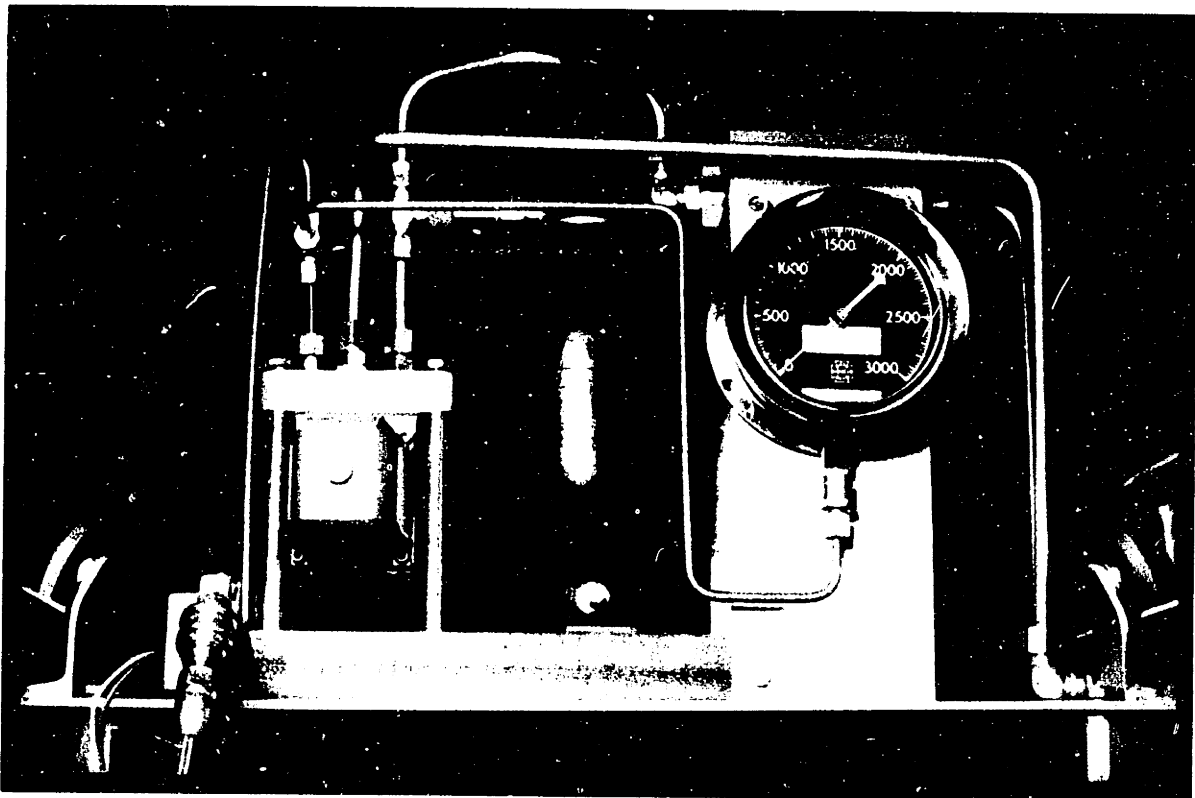

Figure 4-14 OVERHEAD CART HYDRAULIC SYSTEM

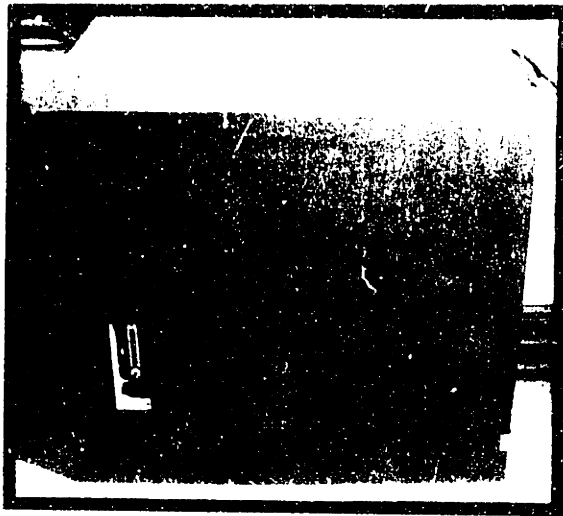

Figure 4-12 ACOUSTIC ENCLOSURE FOR HYDRAULIC POWER SUPPLY

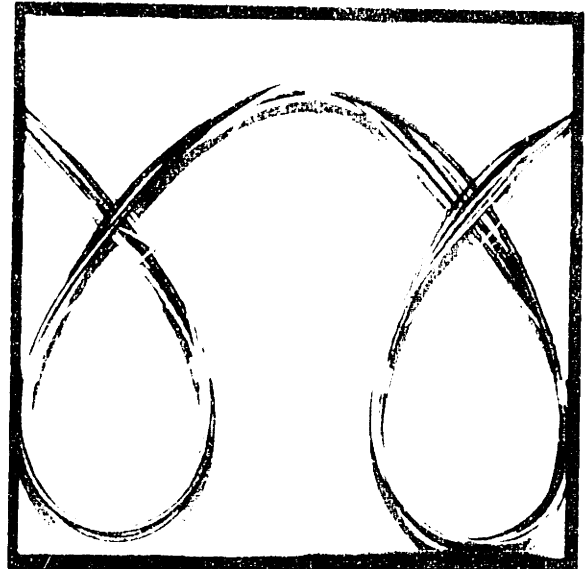

Figure 4-13 UMBILICAL LINE TO OVERHEAD CART

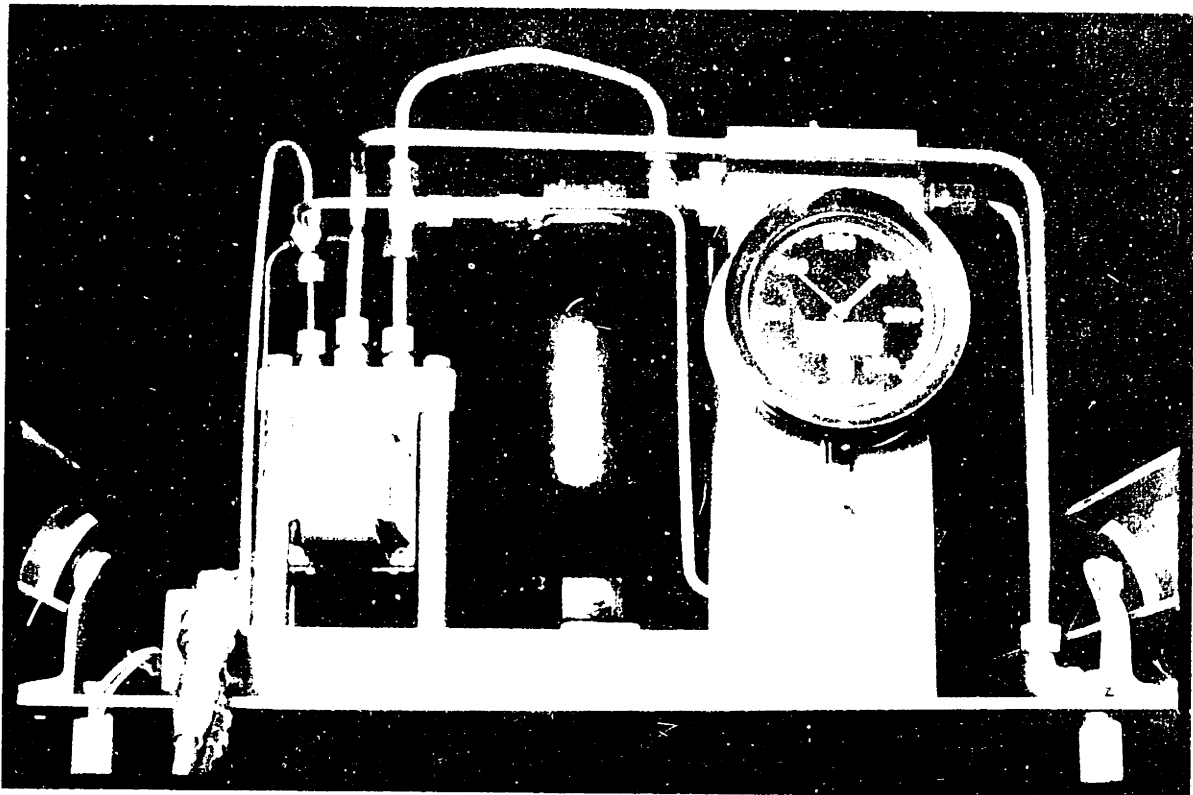

Figure 4-14 OVERHEAD CART HYDRAULIC SYSTEM

INTENTIONAL DUPLICATE EXPOSURE

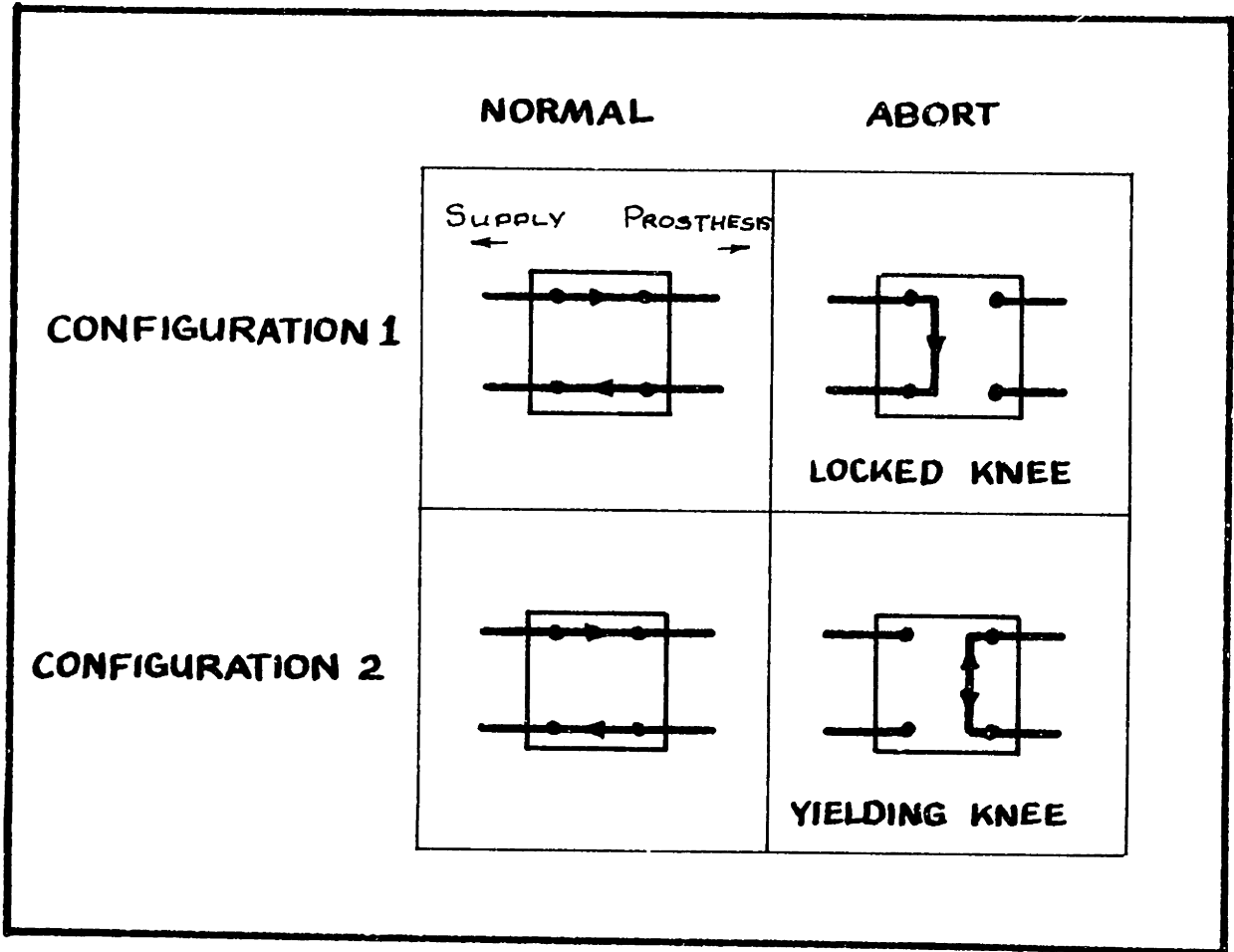

Figure 4-15 OPERATIONAL MODES OF SAFETY VALVE

by a button held by the amputee or by a switch located on the main control panel. This feature allows immediate isolation of the prosthesis acuator in the event of a system malfunction or amputee apprehension.

Stainless steel jacketed nylon pressure hoses connect the overhead system to the leg actuator.

The hydraulic components were designed with a safety factor of 4 referenced to a 1000 psi working pressure.

#### Electrical System

Figures 4-16, 4-17, and 4-18 describe the electrical system.

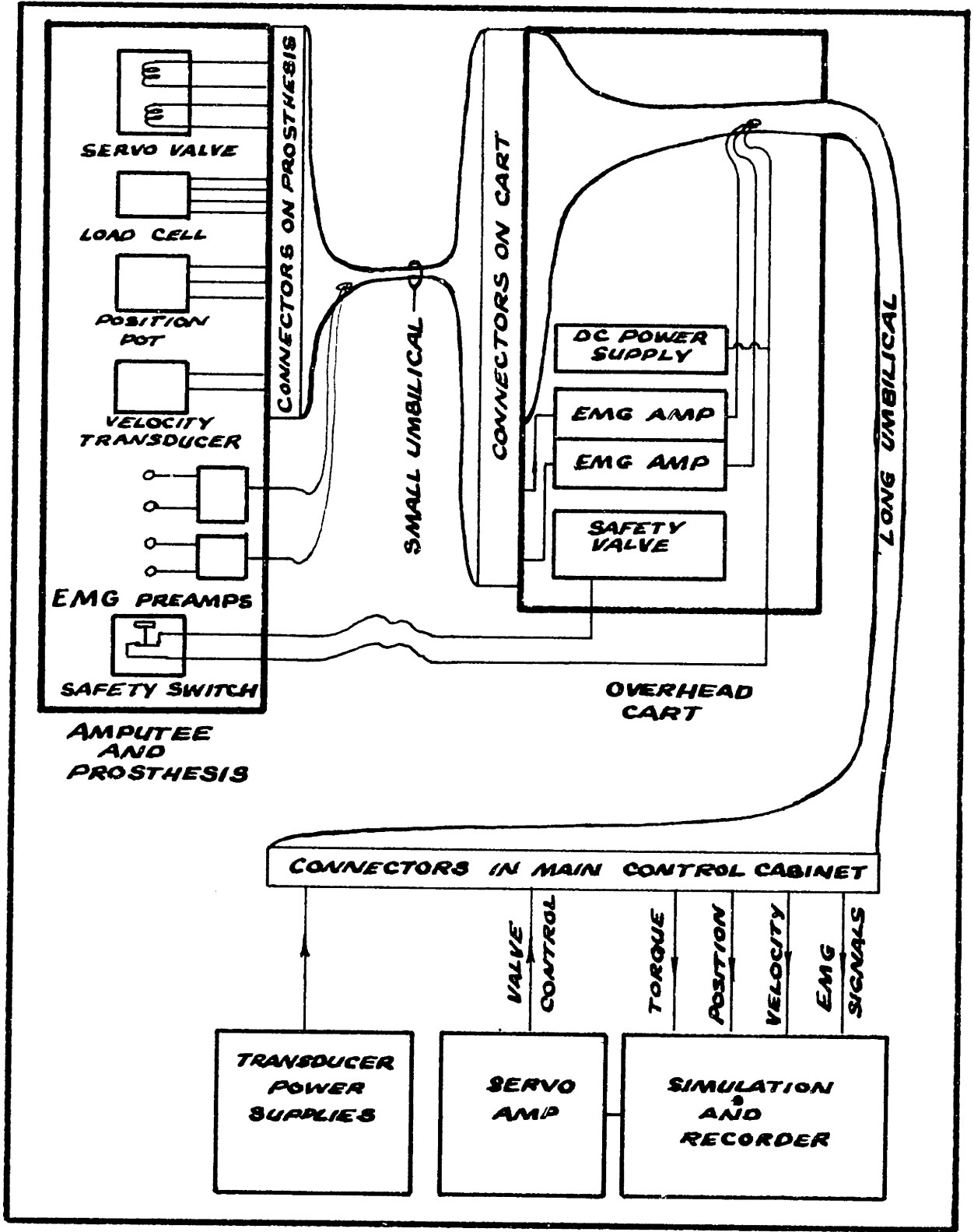

Figure 4-16 SCHEMATIC OF ELECTRICAL SYSTEM

Figure 4-17 MAIN CONTROL  
CABINET

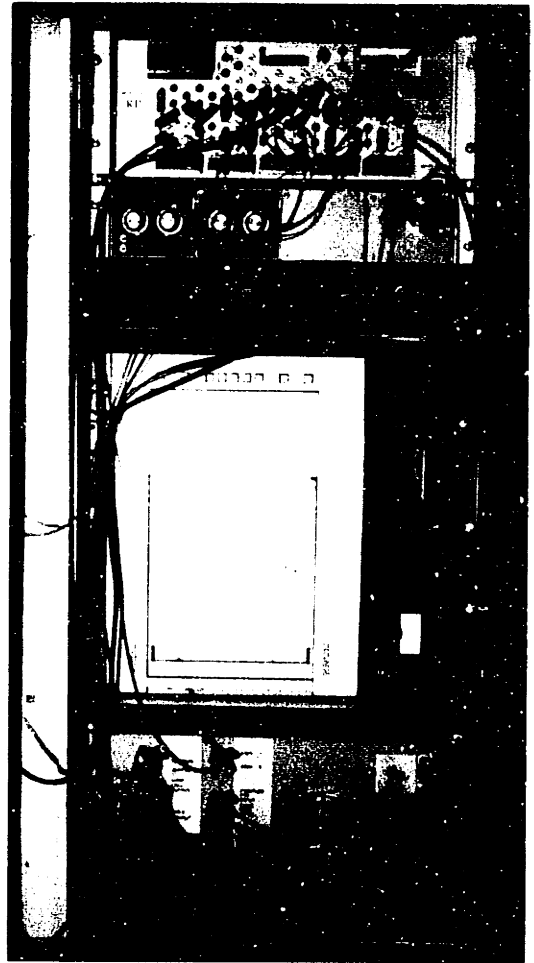

Figure 4-18 OVERHEAD CART  
ELECTRICAL COMPONENTS

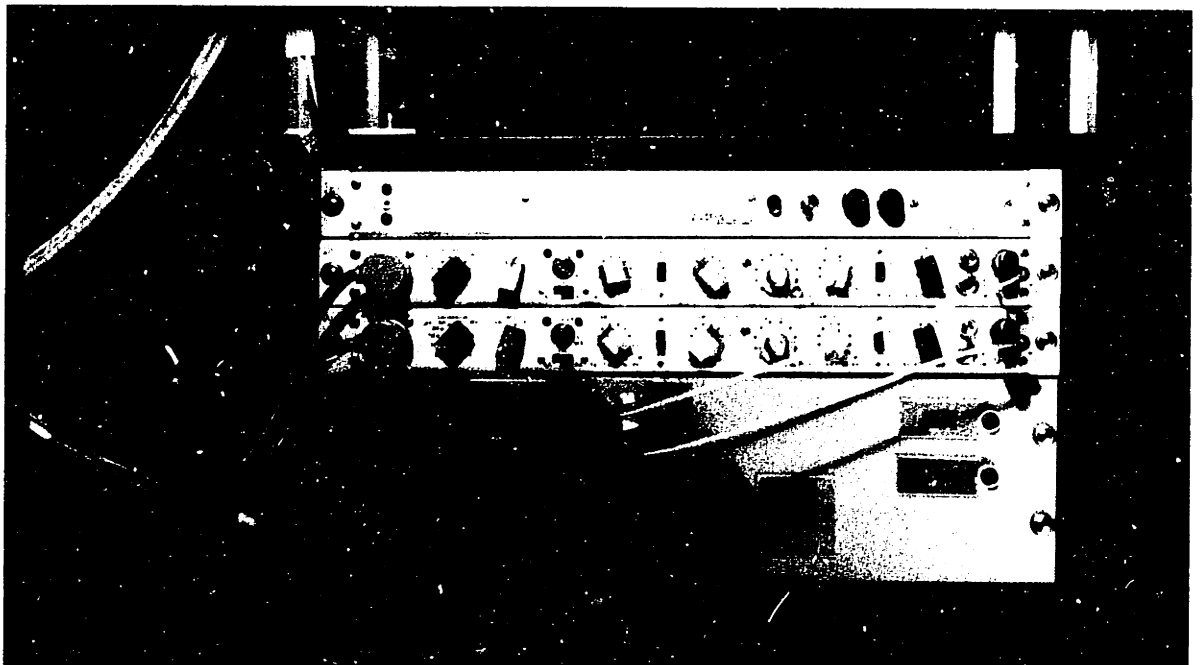

Figure 4-17 MAIN CONTROL  
CABINET

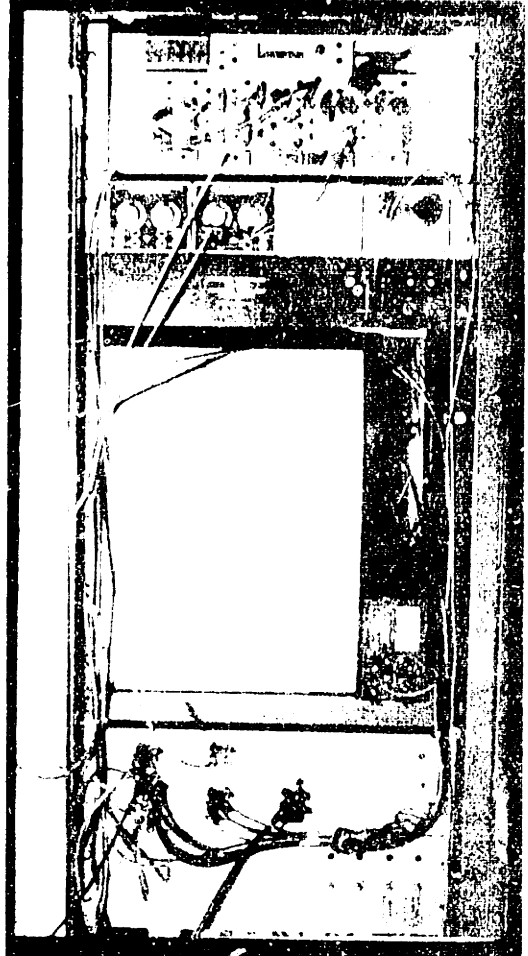
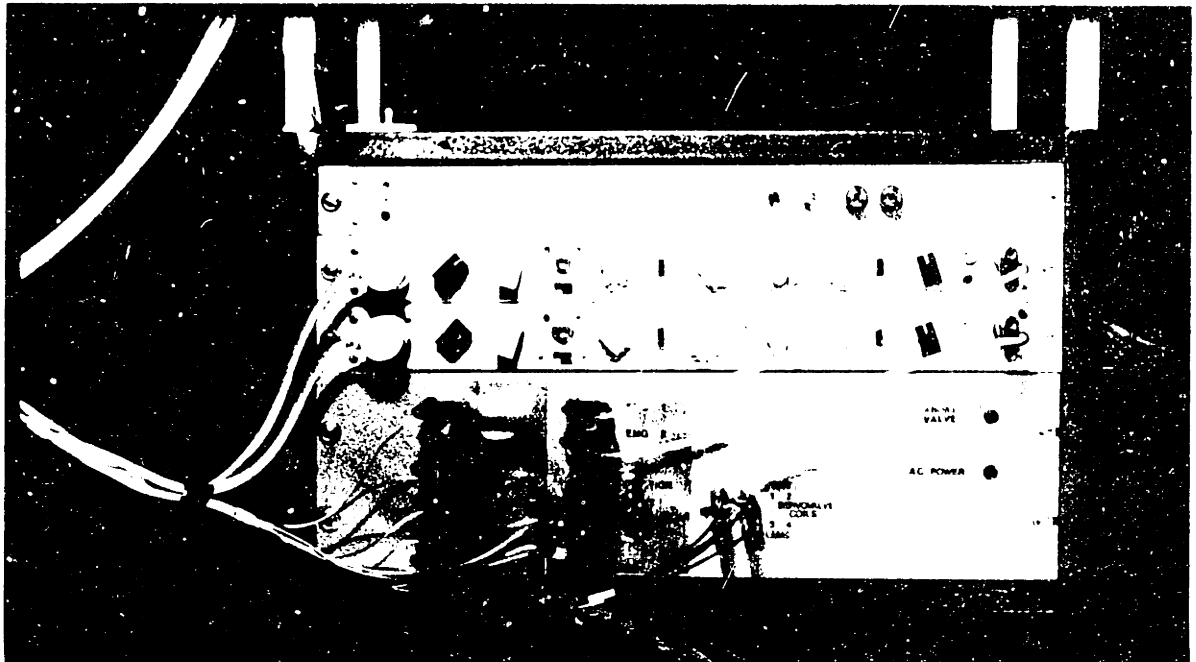

Figure 4-18 OVERHEAD CART  
ELECTRICAL COMPONENTS



INTENTIONAL DUPLICATE EXPOSURE



## Chapter 5

### PERFORMANCE EVALUATION

This chapter defines the performance limits of the simulator system and describes two basic demonstrations in which EMG control was used.

There are four modes of behavior for the prosthesis. See Figure 5-1. The first two cases are zero-power conditions. Case 3 involves power absorption by the knee mechanism, and Case 4 represents its operation as a power source. The performance of the system will be discussed with reference to those four modes.

#### Case 1 - Locked Knee

The servo valve is a flow-control device. With no input signal, the valve is closed preventing knee rotation. This condition constitutes a positive lock which will yield only as a result of structural failure. The leg was designed to withstand over 2000 in-lbs of flexion torque. The extension limit is somewhat lower because of the tendency for buckling in the piston rod. Such high torques should not occur in normal use of the system. An average natural knee joint, for instance, experiences only a maximum of 400 in-lbs in level walking.

#### Case 2 - Free Swinging

This mode involves the most delicate control of the actuator. The potentially powerful piston (500+ pounds force) must maintain minimal force (less than one pound) on the load cell while tracking the

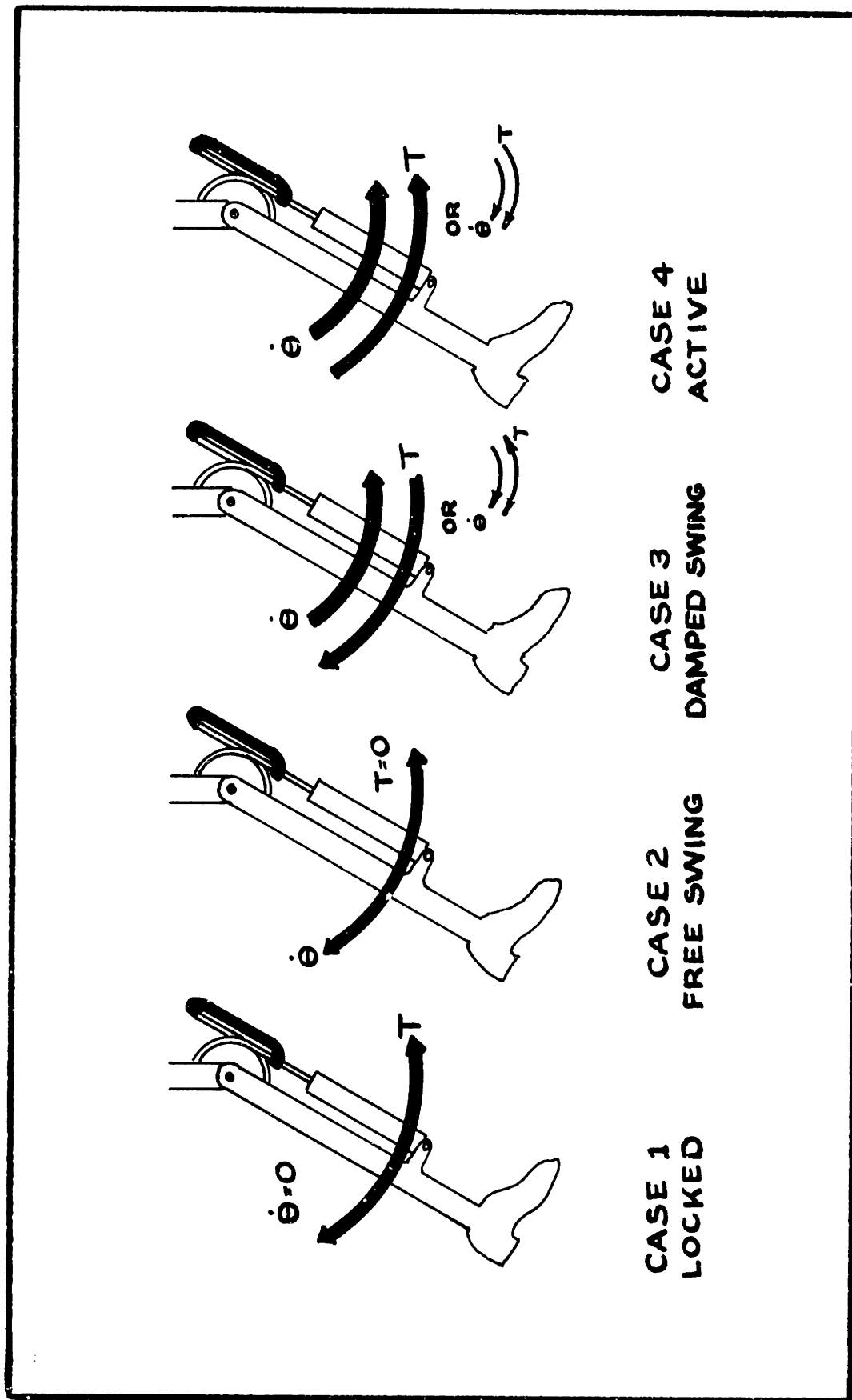

Figure 5-1-1 FOUR POSSIBLE MODES OF OPERATION FOR KNEE MECHANISM

motion of the shank. The model shown in Figure 5-2 will be used to assess the performance of the actuator by comparing its damping to that associated with the knee hinge. The following assumptions are inherent in the model:

- 1) The hinged mass has a uniform distribution and can be considered as a slender rod.
- 2) The servo valve has the linear characteristic

$$P_1 - P_2 = K_p i_c - K_Q Q \quad (5-1)$$

- 3) The dynamics of the transducers and controllers can be neglected.
- 4) The damping in the knee hinge and cable hub assembly can be modeled as viscous in nature ( $b_o$  in Figure 5-2).

These simplifications do not appreciably degrade the model and allow a straightforward comparison between the prosthesis and a damped pendulum.

From Figure 5-2, the following basic equations can be written:

$$I\ddot{\theta} = mg\ell\theta + RF - b_o \dot{\theta} \quad (5-2)$$

since, for small angles,  $\theta \approx \sin\theta$ .

$$F = A_p (P_1 - P_2) \quad (5-3)$$

$$i_c = -K_{FB} K_{LC} F \quad (5-4)$$

$$I = m\ell^2 + \frac{m}{12} (2\ell)^2 \quad (5-5)$$

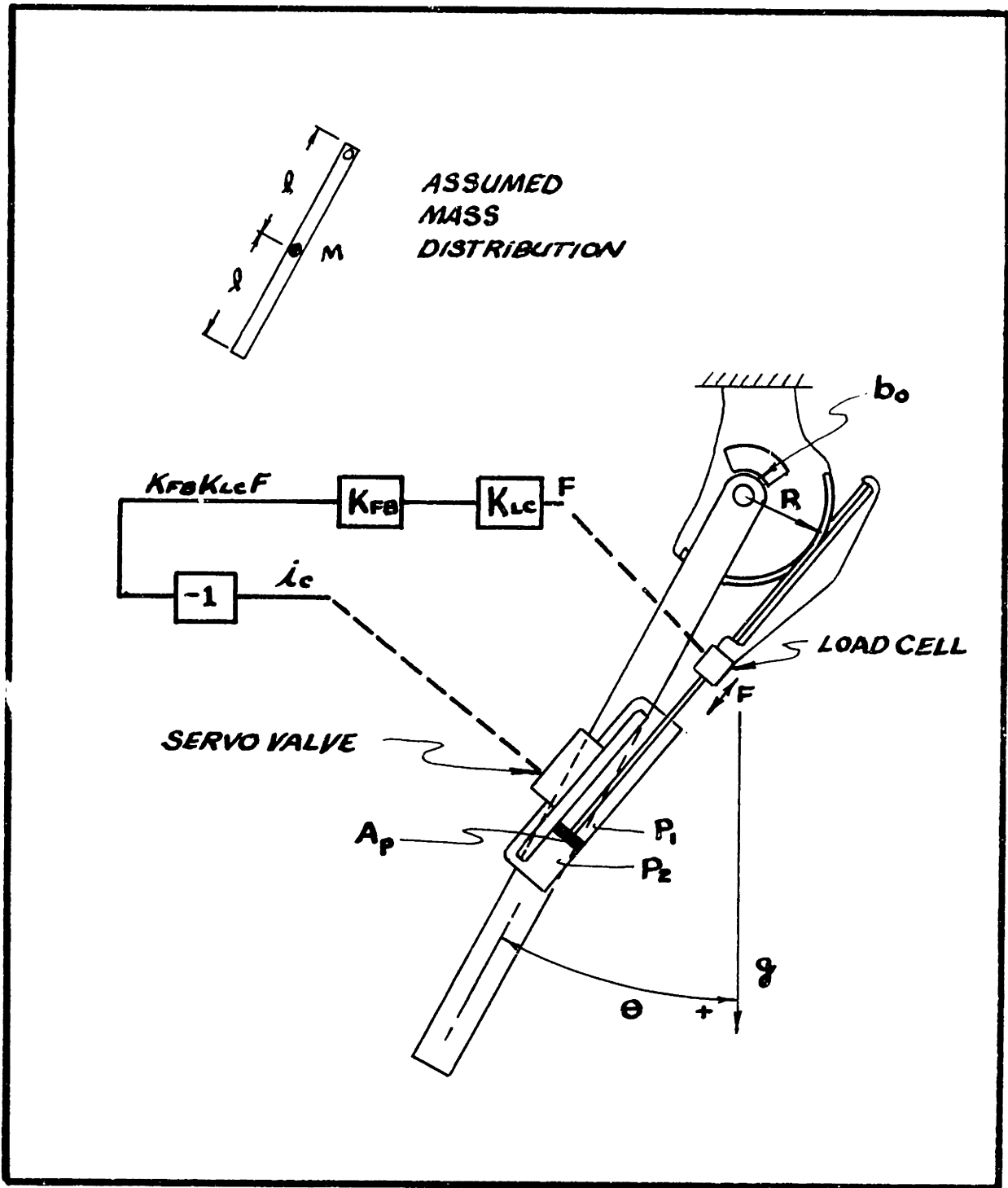

Figure 5-2 PENDULUM MODEL OF PROSTHESIS

Combining and solving in terms of  $\theta$

$$\frac{4\ell}{3g} \ddot{\theta} + \frac{1}{mg\ell} \left[ b_0 + \frac{A^2 K_Q R^2}{1 + \frac{A K_P K_{FB} K_{LC}}{P}} \right] \dot{\theta} + \theta = 0 \quad (5-6)$$

This is an example of a classical second-order equation of the form

$$\left[ \frac{D^2}{\omega_N^2} + \frac{2\zeta D}{\omega_N} + 1 \right] \theta = 0 \quad (5-7)$$

where

$$\omega_N \equiv \text{natural frequency}$$

and

$$\zeta \equiv \text{damping ratio} \quad .$$

The step response of such a second-order equation is a damped harmonic oscillation with a frequency  $\omega_N$ . The rate of amplitude decay is governed by the damping ratio  $\zeta$ . A free-swinging condition requires  $\zeta$  be small. From Equation (5-6) we see that

$$\omega_n = \sqrt{3g/4\ell} \quad (5-8)$$

and

$$\frac{2\zeta}{\omega_n} = \frac{1}{mg\ell} \left[ b_0 + \frac{A^2 K_Q R^2}{1 + \frac{A K_P K_{FB} K_{LC}}{P}} \right]$$

therefore

$$\zeta = \frac{\sqrt{3}}{4m\ell\sqrt{g\ell}} [b_0 + b_1] \quad (5-9)$$

where

$$b_1 \equiv \frac{A_p^2 K_Q R^2}{1 + A_p K_p K_{FB} K_{LC}} \quad .$$

In Equation (5-9) it is seen that the damping is composed of two parts. The first term is a constant determined by the characteristics of the knee hinge and torque coupler. The second term is the contribution of the actuator. In this case

$$A_p K_p K_{FB} K_{LC} \gg 1$$

since the numerator of  $b_1$  is approximately 200, and  $b_1$  is less than 1. Therefore

$$b_1 \approx \frac{A_p K_Q R^2}{K_p K_{FB} K_{LC}} \quad . \quad (5-10)$$

Equation (5-10) points out the need to maximize  $K_{FB}$  to reduce damping. In the real system, the maximum  $K_{FB}$  is limited by instabilities. It can be made large enough, however, to make  $b_1$  very small as illustrated in Figure 5-3. This experimental data allows determination of  $b_1$  by dividing the amplitude of the torque oscillation by the amplitude of the velocity oscillation. This shows

$$b_1 \approx 0.300 \frac{\text{in lbf sec}}{\text{radian}} \quad .$$

Direct calculation of  $b_1$  from Equation (5-10) is not reliable since  $K_p$  is not known and is difficult to determine accurately.

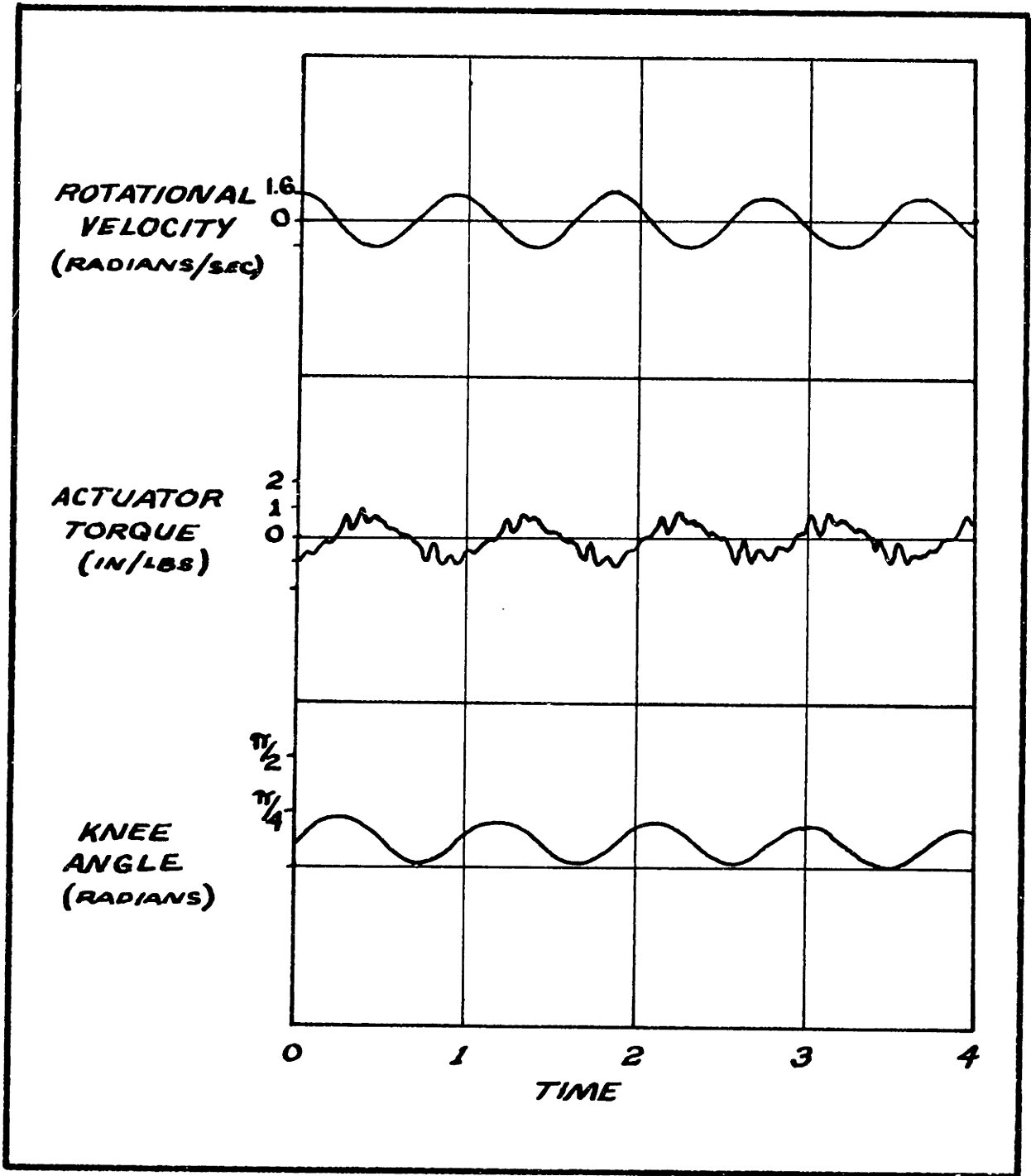

Figure 5-3 PROSTHESIS RESPONSE TO OSCILLATING FORCE ON SHANK

By comparison of  $b_0$  and  $b_1$ , a more intuitive feel for the performance of the actuator can be developed. As shown in Figure 5-4, the prosthesis swings quite freely. The amplitude decay rate is characteristic of a second-order system in which  $\zeta = 0.15$ . Using these experimentally determined values,  $b_0$  can be calculated from Equation (5-9)

$$\zeta = \frac{\sqrt{3}}{4m\ell\sqrt{g\ell}} [b_0 + b_1] \quad (5-9)$$

or

$$0.15 = 0.039[b_0 + 0.300] .$$

Therefore

$$b_0 = 3.58 .$$

This result shows that the actuator is contributing less than 10% of the damping in a lightly damped system.

To attain such precise control very high feedback gains are required. When operating such a responsive system, compensation is usually needed to avoid instabilities. In this system, two additions in the feedback circuit stabilized the actuator. First, a first-order, low-pass filter (break frequency 3 Hz) was added in the torque feedback loop. This filter eliminated the high frequency instabilities by attenuating their feedback. Second, the negative derivative of the torque signal was fed back to control an oscillation associated with



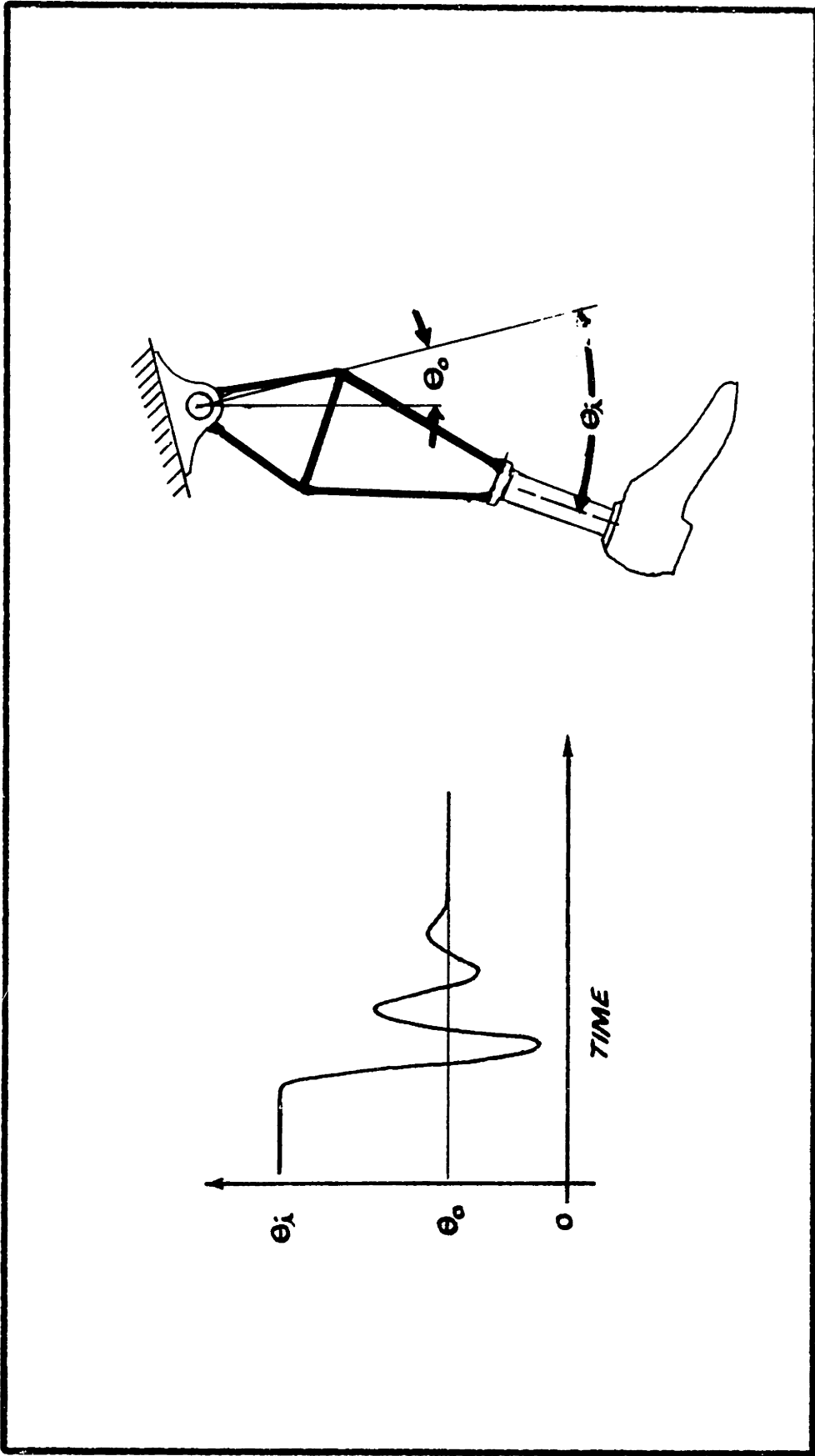

Figure 5-4 STEP RESPONSE IN FREE-SWING MODE

the load-cell-spring and hinged-mass resonance. The residual of this oscillation can be seen on the load cell output in Figure 5-3. As shown by the smooth position and velocity data, the oscillation is too small to noticeably affect the movement of the leg.

### Case 3 - Controlled Damper

A steady-state model will be used to discuss the actuator's behavior as a damper. The model is presented in terms of pressure-flow relations to avoid confusion. At the end of this chapter, these relationships are transformed into rotational velocity-torque curves.

The servo valve is a variable orifice. Its characteristic can be written

$$Q = K_d i_c \sqrt{\Delta P_{\text{valve}}} \quad (5-11)$$

where

- Q ≡ Volume flow rate
- K<sub>d</sub> ≡ Empirical constant
- i<sub>c</sub> ≡ Control signal
- ΔP<sub>valve</sub> ≡ Pressure drop in the valve .

In the simulator system, the valve is not the only source of pressure loss. Pressure drops in the supply and return lines significantly influence the overall flow-pressure characteristics. The hydraulic line flow is laminar in the operating range of the system, therefore

$$\Delta P_{\text{loss}} = R_L Q \quad (5-12)$$

where

$$\begin{aligned} \Delta P_{\text{loss}} &\equiv \text{line pressure drop} \\ R_L &\equiv \text{empirical constant .} \end{aligned}$$

The hydraulic circuit can be modeled as in Figure 5-5. From Equation (5-11),

$$\Delta P_{\text{value}} = \frac{Q^2}{K_d^2 i_c^2} \quad (5-13)$$

therefore,

$$\begin{aligned} \sum \Delta P\text{'s} &= P_{\text{accumulator}} \\ &= R_{LS}Q + R_{LR}Q + \frac{Q^2}{K_d^2 i_c^2} + P_{\text{load}} . \quad (5-14) \end{aligned}$$

Pressure-flow measurements made in the circuit allow the determination of the necessary constants to yield

$$\frac{440 Q^2}{i_c^2} + 250 Q - 900 + P_{\text{load}} = 0 \quad (5-15)$$

where

$$\begin{aligned} i_c &= \text{control signal (milliamps)} \\ Q &= \text{load flow (in}^3\text{/sec)} \\ P_{\text{load}} &= \text{load pressure (lbf/in}^2\text{)} \\ P_{\text{accumulator}} &= \text{average accumulator output pressure} \\ &\quad \text{(lbf/in}^2\text{)} . \end{aligned}$$

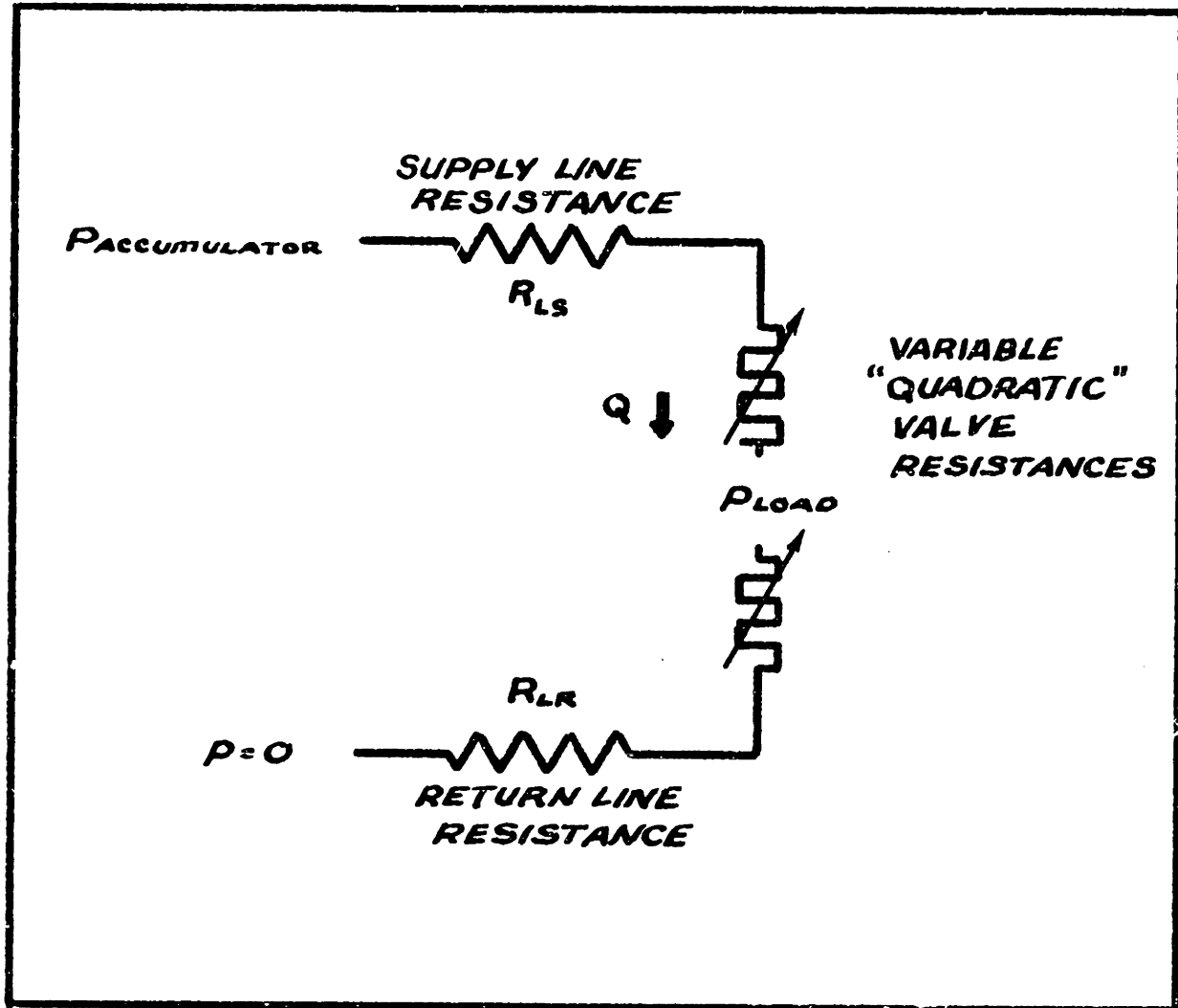

Figure 5-5 FLOW RESISTANCES IN HYDRAULIC CIRCUIT

An average accumulator output pressure of approximately 900 lbf/in<sup>2</sup> results from cycling the actuator to represent the duty cycle of medium gait.

When the system is operated in the passive mode, using torque feedback,

$$i_c = -\kappa_{FB} P_{load} \quad (5-16)$$

where

$$\kappa_{FB} \equiv \kappa_{FB} \kappa_{LC} A_P \quad \dots \text{ composite feedback gain.}$$

making this substitution in (5-15),

$$\frac{440 Q^2}{[\kappa_{FB} P_{load}]^2} + 250 Q - 900 + P_{load} = 0 \quad (5-17)$$

This equation describes the behavior of the actuator when it is operated as a damper.  $\kappa_{FB}$  is considered to be variable. Figure 5-6 illustrates solutions to Equation (5-17) for several values of  $\kappa_{FB}$ . Equation (5-17) is valid for positive Q's as defined in Figure 5-5. The curves for negative values of Q are obtained by rotating the positive-Q curves 180° about the origin.

It is seen that the braking or damping pressure is always in opposition to the flow and is increased as  $\kappa_{FB}$  decreases. The slope of these curves at any point is the damping coefficient. When Q is small, the slope is nearly constant -- indicating the behavior of an ideal viscous dashpot. For large values of Q, flow saturation causes the actuator characteristic to approach an asymptote regardless of the

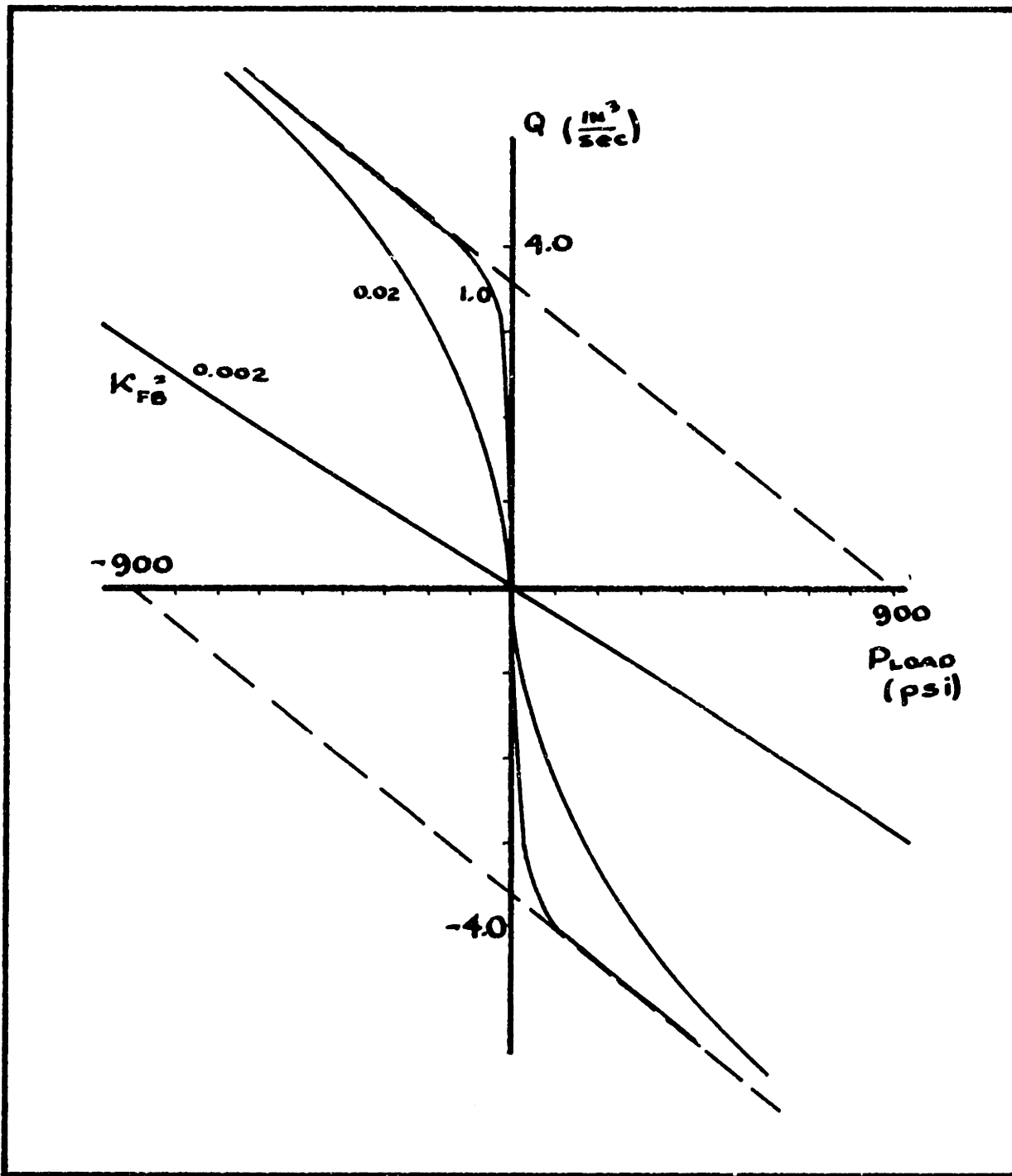

Figure 5-6 ACTUATOR RESPONSE IN PASSIVE MODE

magnitude of  $\kappa_{FB}$ . The asymptote is the performance limit for no pressure drop in the valve, i.e. only supply and return line losses.

Case 4 - Powered Knee

In the active mode, the knee mechanism produces a torque in the same direction as the rotational velocity in response to an input signal. Using the same model as in Case 3,

$$i_c = i_o - \kappa_{FB} P_{load} \quad (5-18)$$

where  $i_o$  is the input signal. Substituting in Equation (5-15)

$$\frac{440 Q^2}{[i_o - \kappa_{FB} P_{load}]^2} + 250 Q - 900 + P_{load} = 0 \quad (5-19)$$

The solutions to this equation are shown in Figure 5-7 for  $\kappa_{FB} = 0.01$ . In the first and third quadrants, the actuator is exhibiting typical motor characteristics. If no flow is allowed, the output pressure is proportional to the input signal. As the flow rate increases, the output pressure drops until the load pressure is zero (Q axis in Figure 5-7). If the load becomes negative, work is done on the actuator and the state of the system is described in the second and fourth quadrant.

$\kappa_{FB}$  determines when the constant- $i_o$  curves intersect the  $P_L$  axis. Figure 5-7 illustrates a mid-range value for  $\kappa_{FB}$ . When  $\kappa_{FB}$  is zero, the characteristic is as Figure 5-8. When  $\kappa_{FB}$  is infinite the valve is always open and the system behavior is governed only by the hydraulic line resistance.

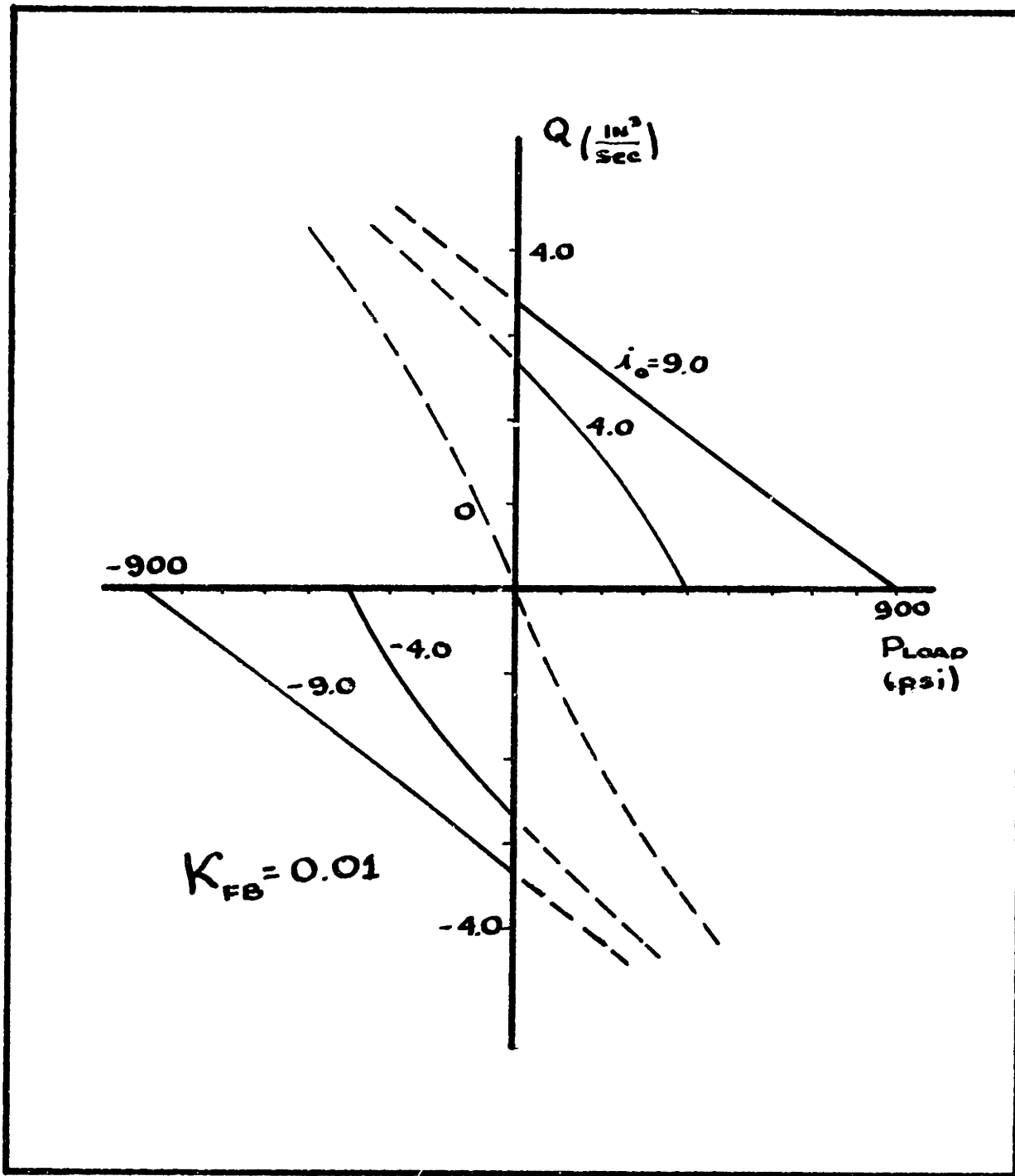

Figure 5-7 ACTUATOR RESPONSE IN THE ACTIVE MODE



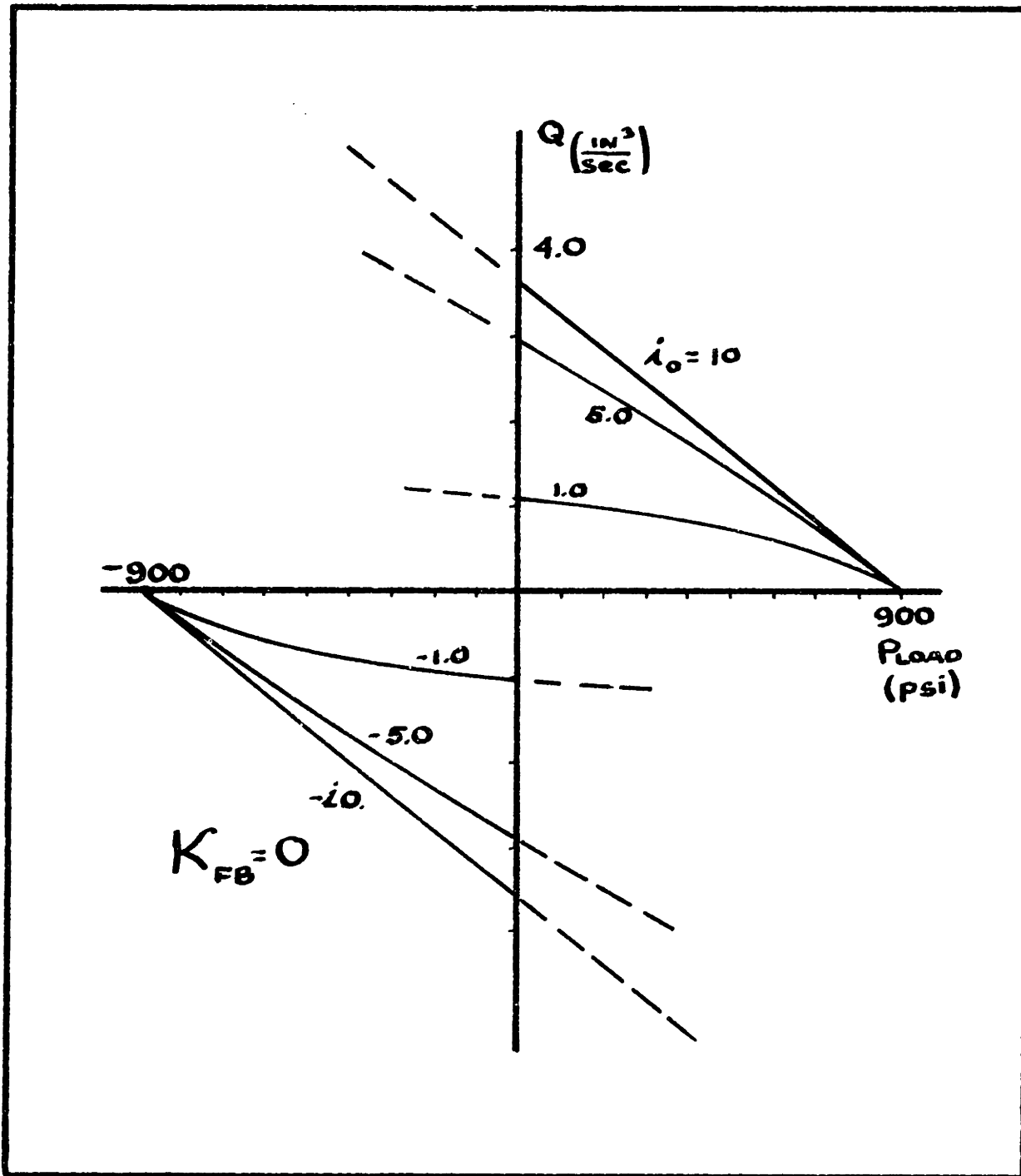

Figure 5-8 ACTUATOR RESPONSE WITHOUT FORCE FEEDBACK

### Performance Summary

Figure 5-9 is a condensation of the performance limits. The shaded region indicates the approximate limits of a human knee joint. That region is imprecise because of the human variability and the wide range of man's capabilities, but it does serve to elucidate the significance of the performance limits of the simulator system. As has been explained in this chapter, the characteristics of the prosthesis can be electronically adapted to any curve or curves within the indicated region, thus providing the capability of simulating any currently existing mechanism and variants not otherwise available.

### EMG Control Demonstrations

Two preliminary experiments involving EMG control were conducted for demonstrative purposes. They were designed for an illustrative movie and qualitatively show the ease with which the simulator knee mechanism can be interfaced with bioelectric signals. For convenience, the extensor muscles on the dorsal surface of the forearm were used as control sites. Figure 5-10 is a schematic of the control scheme.

With no EMG input, the system was adjusted to allow the knee to swing freely.  $V_{ADD}$  was a constant bias to insure that the feedback gain remains finite when  $EMG = 0$ . Increased EMG activity caused the torque feedback gain ( $\kappa_{FB}$ ) to be reduced. With this simple scheme, it was possible to proportionally control the damping torque. An essentially locked knee joint resulted from full, but unstrained, dorsiflexion of the wrist.

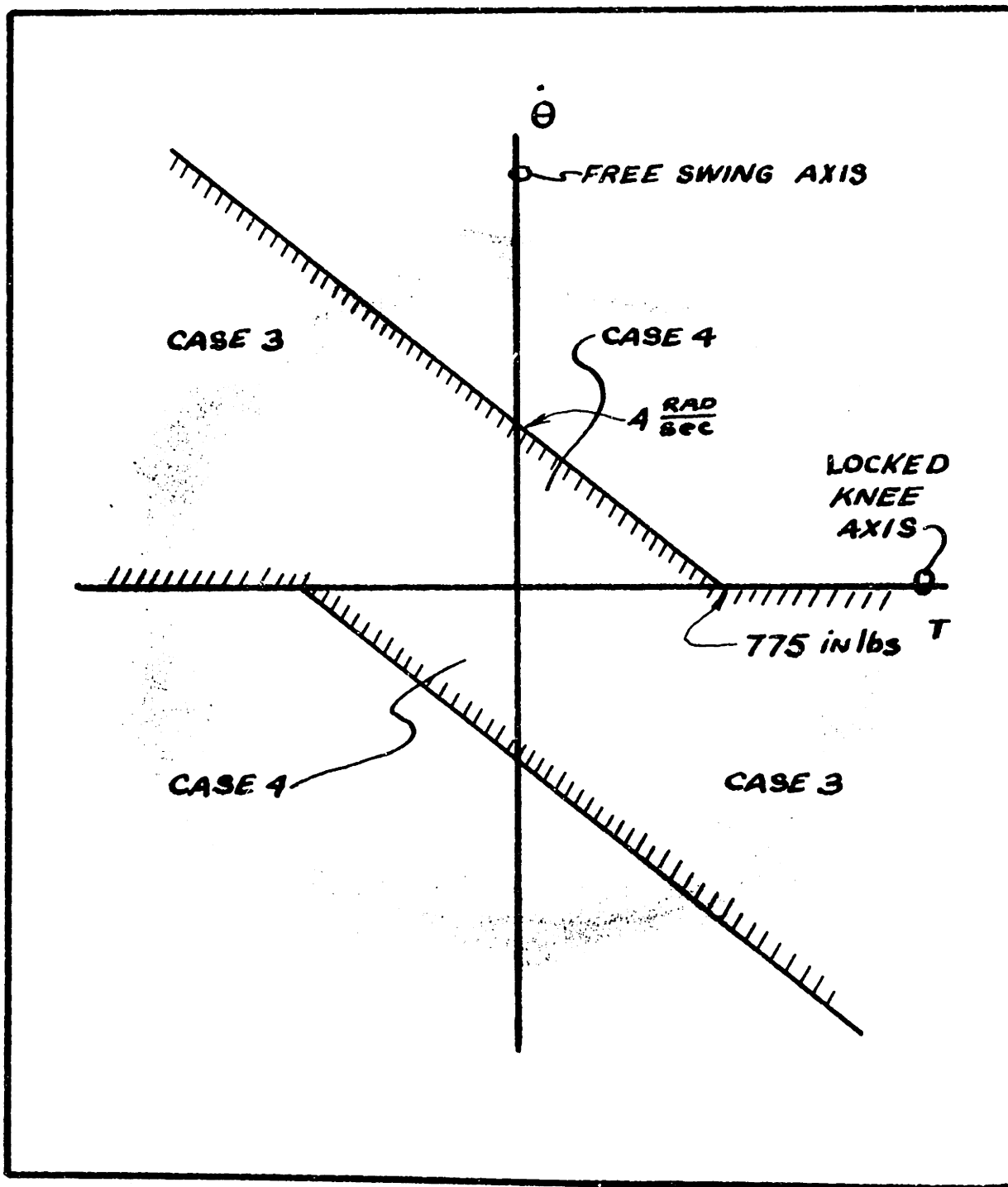

Figure 5-9 SUMMARY OF PERFORMANCE LIMITS FOR SIMULATOR SYSTEM

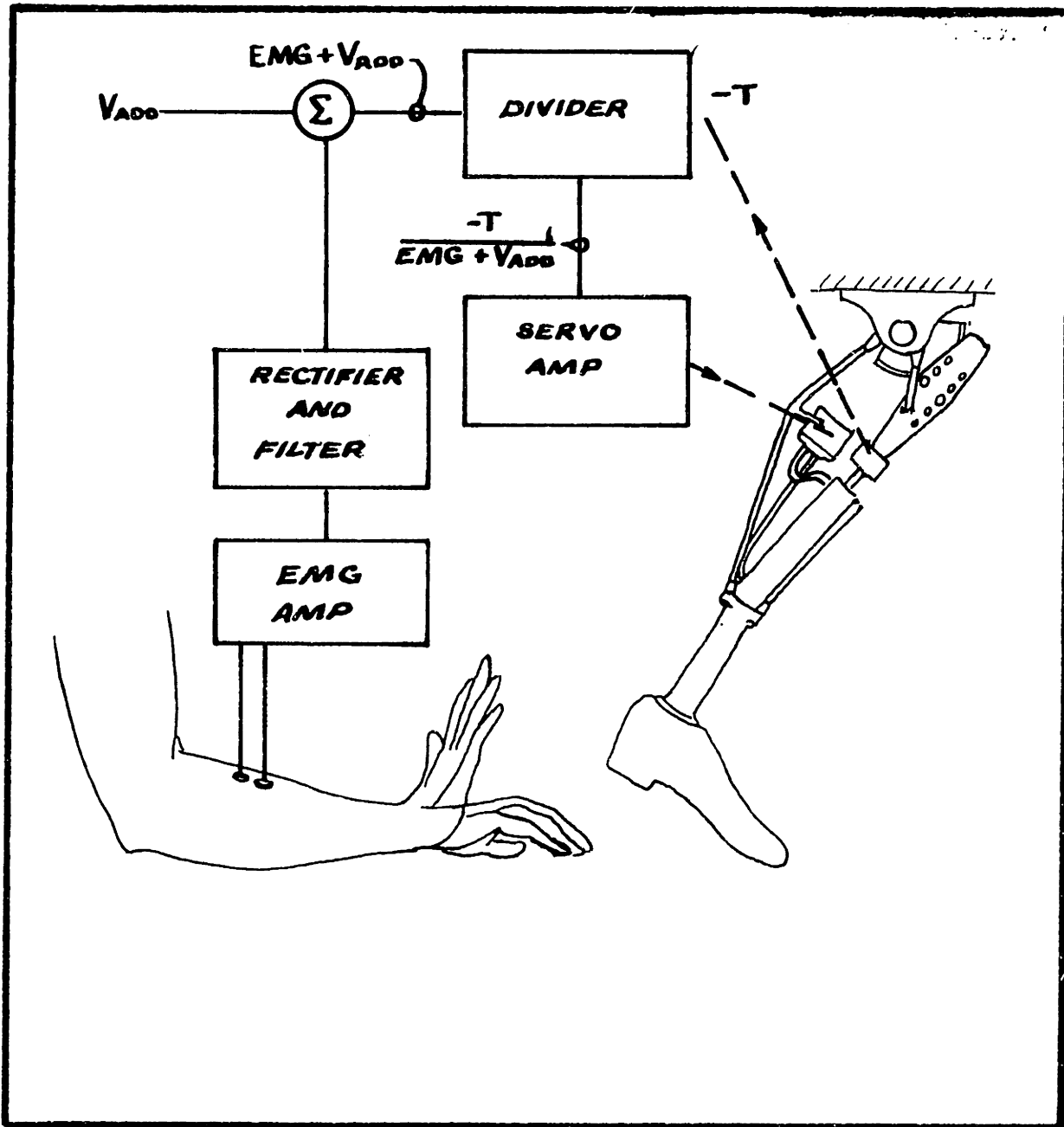

Figure 5-10 EMG CONTROL DEMONSTRATION SCHEMATIC

The second demonstration illustrated active flexion control. Torque feedback allows the shank to hang vertically and eliminate torque at the knee. If a flexion bias is added in the servo amplifier, the leg will flex against gravity until the bias signal is cancelled by the load cell output. If the torque feedback gain is reduced, additional flexion occurs before an equivalent feedback voltage is generated. Therefore, with the same circuit as used in the previous experiment, the knee behavior was changed from passive to active by the addition of a bias. In this configuration, the prosthesis knee flexed as the controller's wrist extended.

In both cases, rapid response and smooth control were easily accomplished. Another pleasing aspect of the system is that the prosthesis itself generates very little noise, even at maximum slewing rate.

Chapter 6

SUMMARY AND SUGGESTIONS

A man-interactive simulator system for A/K-prosthesis knee mechanism control studies has been designed, constructed and tested. Its performance limits encompass existing prosthetic mechanism characteristics. The system is easily interfaced with analog or digital computational facilities and with bioelectric signals. Therefore, it should allow evaluation, by an amputee, of any EMG control scheme and/or knee mechanism whose characteristics can be electronically simulated.

The next step in the program will be recruiting an amputee and having a socket fabricated so that the EMG control feasibility study can proceed.

The following procedure might be appropriate:

- 1) After the amputee is fitted and the prosthesis aligned, the system could be set up to simulate a classical knee mechanism. A simple example would be a viscous swing phase damper with a load-bearing activated lock and extension bias. Chapter 5 has shown that this behavior can be obtained by adjusting two parameters (turning two potentiometer knobs) and providing a sensor for recognition of weight bearing. A heel-contact switch, for instance, could make  $\kappa_{FB}$  zero and lock the knee during stance.

- 2) The amputee could then "tune" the prosthesis to optimize his mobility (possibly through a hand-held console allowing adjustments as he walks).
- 3) Then, EMG data should be collected to establish the manner in which the amputee's musculature is "driving" the artificial limb in various walking situations.
- 4) From comparison of the leg's temporal behavior with the muscle groups' activity, control schemes can be hypothesized.
- 5) The hypotheses can then be tested.

This particular man-interactive technique appears to have wide applicability in prosthetic research, especially in studies concerning lower limb prostheses and orthoses. The most unfortunate feature of the system described in this thesis is its complexity. Therefore, aside from the EMG control studies, the system might be used to design a simpler simulator system. If an acceptable, controllable, passive actuator could be developed, the power-transmitting umbilical lines could be replaced by information channels. Thus communication between the mobile amputee and the stationary simulation could be accomplished through telemetry.

REFERENCES

1. Basmajian, J.V., Muscles Alive, Baltimore: Williams & Wilkins Co., 1967.
2. Hartman, H. et al., "Myoelectric Control of Upper-Extremity Joint Motion", Proceedings of the Third International Symposium on External Control of Human Extremities. Dubrounik; pp. 254-260, 1969.
3. Horn, G.W., "Electro-Control: An EMG-Controlled A/K Prosthesis", Medical and Biological Engineering, Vol. 10, pp. 61-73, 1972.
4. Inman, V.T., "Conservation of Energy in Ambulation", Bulletin of Prosthetics Research, BPR 10-9, pp. 26-35, 1968.
5. Jacobsen, S.C., "Control of ~~Multi-Axis~~ Prosthetic Limbs", Doctoral Thesis, to be published, M.I.T., 1972.
6. Jacobsen, S.C. and Hogan, N., EMG Preamplifiers, Amplifiers and Processors. Research in progress. M.I.T., 1972.
7. Klopsteg and Wilson, et. al., Human Limbs and Their Substitutes, New York, Hafner, 1968.
8. Lemman, J.A.R., and Ritchie, H.E., Clinical Electromyography, Philadelphia; Lippincott, 1970.
9. Mann, R.W., "Efferent and Afferent Control of an Electromyographic, Proportional-Rate, Force Sensing Artificial Elbow with Cutaneous Display of Joint Angle", The Basic Problems of Prehension Movement and Control of Artificial Limbs, London; The Institution of Mechanical Engineers, 1969.



10. Mann, R.W., "Man-Interactive Systems in the Design of Prostheses for the Maimed and Blind", IEEE Systems Science and Cybernetics Conference, Pittsburgh, Pa., 1970.
11. May, D.R.W., "The Development of a Comprehensive External Prosthetic Knee Control", Proceedings of the Conference on Human Locomotor Engineering, University of Sussex, pp. 179-198, 1971.
12. Morrison, J.B., "The Mechanics of Muscle Function in Locomotion", Journal of Biomechanics, Vol. 3, pp. 431-451, 1970.
13. Morrison, J.B., "Function of the Knee Joint in Various Activities", Bio-Medical Engineering, pp. 573-580, December 1969.
14. Morrison, J.B., "Bioengineering Analysis of Force Actions Transmitted by the Knee Joint", Bio-Medical Engineering, pp. 164-170, 1968.
15. Paul, J.P., "The Biomechanics of the Hip-Joint and its Clinical Relevance", Proceedings of the Royal Society of Medicine, Vol. 59, No. 10, pp. 943-948, 1966.
16. Paul, J.P., "Comparison of EMG Signals from Leg Muscles with the Corresponding Force Actions Calculated from Walkpath Measurements", Proceedings of the Conference on Human Locomotor Engineering, University of Sussex, pp. 13-28, 1971.
17. Radcliffe, C.W., "Biomechanical Design of an Improved Leg Prosthesis", Biomechanics Laboratory, University of California, Berkeley, Ser. 11, Issue 33, 1957.

18. Ralston, H.J. and Lukin, L., "Energy Levels of Human Body Segments During Level Walking", Ergonomics, Vol. 12 , No. 1, pp. 39-46, 1969.
19. Scott , R.N., "Myoelectric Control of Prostheses and Orthoses", Bulletin of Prosthetics Research, BPR 10-7, pp. 93-114, 1967.
20. Staros , A., "Joint Designs for Orthotics and Prosthetics", Prosthetics International, Vol. 3, No. 10, pp. 1-20, 1970.
21. "UCB Pneumatic A/K Swing Control Knee Mechanism", Bulletin of Prosthetics Research, BPR 10-6 , p. 234, 1966.
22. "Variable Friction Knee Unit for Swing Phase Control in Artificial Legs", Final Technical Report, Navy Prosthetic Research Laboratory, Oakland, Calif., 1970.
23. Wallach, J., "Control Mechanisms Performance Criteria for an Above-Knee Leg Prosthesis", Ph.D. Thesis , Rensselaer Polytechnic Institute, 1966.
24. Weltman, G., Groth, H. and Lyman, J., "An Analysis of Bioelectrical Prosthesis Control", Biotechnology Laboratory Technical Report No. 1, University of California, Los Angeles, Report No. 59-49, 1959.
25. Wilson, A.B. , "Recent Advances in Above-Knee Prosthetics", Artificial Limbs, Vol. 12, No. 2, pp. 1-27, 1968.
26. Wirta, R.W. and Taylor, D.R., Jr., "Development of a Multiple-Axis Myoelectrically Controlled Prosthetic Arm", Proceedings of the Third International Symposium on External Control of Human Extremities. Dubrounik, pp. 254-260, 1969.

BIOGRAPHICAL NOTE

WOODIE CLAUDE FLOWERS

EDUCATION

Jena High School  
Jena, Louisiana  
1957-1961

Northwestern State College  
Natachitoches, Louisiana  
Freshman Year 1961-62

University of Texas  
Austin, Texas  
National Science Foundation Summer Research Program  
Summer 1965

Louisiana Polytechnic Institute  
Ruston, Louisiana  
1962-1966  
Bachelor of Science Degree

Massachusetts Institute of Technology  
Cambridge, Massachusetts  
1966-1972  
Master of Science Degree 1968  
Thesis: "Sound Transmission in Paper Pulp Slurries"  
Mechanical Engineering Degree 1971

SOCIETIES AND HONORS

Louisiana Polytechnic Institute

Tau Beta Pi; Pi Tau Sigma; Phi Kappa Phi; Omicron Delta Kappa; American Society of Mechanical Engineers; Baker Foundation Scholarship; Magna Cum Laude Graduate; Who's Who in American Colleges and Universities.

Massachusetts Institute of Technology

Sigma Xi; Ralph E. Teetor Award by The Society of Automotive Engineers; The Goodwin Medal by the Massachusetts Institute of Technology.

PROFESSIONAL AND TEACHING EXPERIENCE

Instructor, Massachusetts Institute of Technology  
1968-1972

Research Assistant, Massachusetts Institute of Technology  
1966-1968

Assorted summer jobs

PUBLICATIONS

"A Sound-Source Ball for Blind Children", Research Bulletin,  
1968, American Foundation for the Blind.

Accepted for presentation:

"A Man Interactive Simulator System for Above-Knee  
Prosthetic Studies", Annual Conference on Engineering  
in Medicine and Biology, October 1972, Bal Harbour, Florida.