

TOWARDS A THEORY OF PHONOLOGICAL ALPHABETS

by

ANDREA CALABRESE

Laurea in Lettere e Filosofia, Università di Padova

(1980)

Submitted to the Department of
Linguistics and Philosophy
in partial fulfillment of the requirements for the degree of

DOCTOR OF PHILOSOPHY

at the

MASSACHUSETTS INSTITUTE OF TECHNOLOGY

May, 1988

© Andrea Calabrese, 1988

The author hereby grants to M.I.T. permission to reproduce and to distribute copies of this thesis document in whole or in part.

Signature of Author _____

Department of Linguistics and Philosophy
May, 1988

Certified by _____

Thesis Supervisor

Accepted by _____

Chairman, Departmental Committee

MASSACHUSETTS INSTITUTE OF TECHNOLOGY

JUN 8 1988
ARCHIVES

TOWARDS A THEORY OF PHONOLOGICAL ALPHABETS

by

Andrea Calabrese

Submitted to the Department of Linguistics and Philosophy
on May 20, 1988 in partial fulfillment of the
requirements for the degree of Doctor of Philosophy in
Linguistics

Abstract

One of the basic tenets of phonology is that every language has an inventory of phonological segments used to distinguish lexical items in underlying representations. I call the inventory of phonological segments of a given language the phonological alphabet of that language. Each phonological alphabet is always organized according to a precise pattern and has a well-defined structure. In this thesis, I argue that negative conditions on feature cooccurrence are the correct means to represent the structure of a phonological alphabet. I call these negative conditions on feature cooccurrence filters. An example of filter is the following: (i) *[+low, -back]. (i) represents the fact that the feature values [+low] and [-back] cannot occur together in the same feature bundle. I hypothesize that when a filter holds in a given language, the phonological segment which is characterized by the configuration of features disallowed by the filter is absent from the phonological alphabet of that language. Thus, I represent the fact that the low front vowel /æ/ is absent from the phonological alphabet of Italian by hypothesizing that the filter *[+low, -back] holds in Italian.

I propose that there is a set of filters provided by Universal Grammar, which I call UG filters. I propose that UG filters are hierarchically ordered: the more complex a phonological segment is, the higher the filter that excludes it is in the hierarchy. The hierarchy of UG filters is also intended to account for Jakobson's (1941) observations on language learning and loss, as well his observations on the universal implications about the structure of phonological alphabets.

In Chapter 1, I demonstrate that hierarchically ordered UG filters

are needed to represent generalizations about phonological alphabets. In this chapter, I also argue that Universal Grammar provides a set of rules that have the function of repairing configurations of features which violate filters. I call these rules clean up rules. By hypothesizing an interaction among phonological rules, filters and clean up rules, I account for several phonological phenomena in a straightforward way. Finally, I attempt to account for situations in which filters can block the application of rules and how configurations of features disallowed by filters may surface without being repaired by clean up rules. In doing this, I also present some arguments against the Structure Preservation Principle proposed by Kiparsky (1984, 1985).

In Chapter 2, I discuss the Theory of Underspecification. The central idea of the Theory of Underspecification is that not all of the feature values characterizing a segment are phonologically relevant, and that the phonologically irrelevant feature values are underlyingly unspecified. In this chapter, I argue that the feature values which are phonologically relevant in the segments of a given phonological alphabet are determined by the structure of that phonological alphabet, and specifically by the UG filters which are underlyingly violated in that phonological alphabet. In this chapter, I also discuss the Theory of Underspecification proposed by Archangeli (1984) and Archangeli and Pulleyblank (1986) and the Theory of Underspecification proposed by Steriade (1987).

In Chapter 3, I argue that language-specific filters are needed in addition to the UG filters in order to account for the structure of phonological alphabets. These language specific filters can be acquired only through negative evidence and have a very marginal phonological status. I will show that they do not play a role in the Theory of Underspecification.

In Chapter 4, I discuss the different clean up rules which I propose. In this chapter, some modification of the formalism adopted to represent them will be proposed.

Thesis Supervisor: Morris Halle
Title: Institute Professor-Professor of Linguistics

Acknowledgements

In every act of thanks, there is the history of a soul which realized its desires. In the following acknowledgements, there is the history of my soul during the last five years.

At the beginning of my first paper in Phonology, two years ago, I quoted the following passage from Plato's Phaedrus:

"Socrates [...] What ground, you may ask, have I for saying so? Good sir, there is something welling up within my breast, which makes me feel that I could find something different, and something better, to say. I am of course well aware it can't be originating in my own mind, for I know my own ignorance: so I suppose it can only be that it has been poured into me, through my ears, as into a vessel, from some external source, though in my stupid fashion I have actually forgotten how, and from whom, I heard it."

(Plato, Phaedrus 235c)

If in that confused time I was not able to remember who was pouring knowledge into my ears, now that I begin to distinguish light from shadows, I clearly know to whom I owe my knowledge and to whom I owe my gratitude. If this thesis exists, it is because Morris Halle, Donca Steriade and Jim Harris, like ancient masters, have taught a little of their art to me, the apprentice, in that "bottega d'arte" that is the Department of Linguistics at MIT.

Morris Halle's maieutic formed me not only as a linguist, but also as a person. Morris, my Socrates, will remain an unforgettable example of great scientific and moral teaching for me for the rest of my life.

When I first met Donca Steriade, I knew nothing about Phonology. Donca was my first teacher of Phonology. From her, I not only learned Phonology, I learned an entirely new way of thinking in Phonology. Only thanks to her continuously challenging me to give arguments was I

able to overcome my lack of mental discipline enough to write this thesis with a minimum of coherence and theoretical interest.

The matchless ability of Jim Harris in dissecting an argument and in individuating the weak points of a theory has been fundamental in my growing as a phonologist and linguist.

There is a fundamental truth that I learned in these last years at MIT that I need to disclose here because I believe it is the most important thing that I have learned at MIT. For years, I thought that I knew too little and had to learn more and more to overcome that. At MIT, I have finally realized that I will always know very little because of the limits of my mind and my memory and because of the unending nature of knowledge. This discovery would have only anguished me just a few years ago. But now I can face it with serenity, because I have also discovered something else of fundamental importance. What matters--and this is what I finally realized--is not learning, accumulating knowledge or facts, but the desire to understand, to imagine solutions, ideas, to capture the facts in order to guess their secret. What matters is in the depth of the researcher's soul, in that divine spark that urges human beings to search for an answer: "Fatti non foste per vivere come bruti, ma per seguir virtute e conoscenza" Ulisses says in Dante's *Inferno*. I learned with fatigue and pain that the most important virtue is humility: history changes, theories die and come to life, like human beings in this world of vanity. We cannot assume to have arrived at a perfect, still point. In every idea, in every fact there can be the gold of knowledge.

There are a lot of people to whom I feel gratitude for what they gave me in these last years. This is the right place to thank them.

I want to thank Ken Hale. Ken represents a lot for me. There was a moment during my stay at MIT when I decided to abandon Linguistics which, at that time, was only Syntax for me. In speaking with Ken about the topics that were of interest to me at that time, I understood that studying Linguistics still had a meaning for me.

I thank Luigi Rizzi and Adriana Belletti for their help and support during these last years, in Pisa and Cambridge. I especially thank Luigi. Without his help this thesis would not exist. I will be grateful to him

forever.

I thank my friends from Padova: Paola Benincà, Guglielmo Cinque, Lorenzo Renzi and Laura Vanelli. If I have achieved anything in linguistics, it is because of their teaching, encouragement and friendship.

I thank Ewa Higgins who has been my friend in my most difficult moments. I could not have survived MIT without Ewa's support

I thank all of the members of MIT linguistic community, but in particular I thank Jay Keyser for his encouragement and his *simpatia* during all these years, Luigi Burzio for his encouragement, support and help, and Maggie Browning, Maggie Carracino, Hyon Sook Choe, Jennifer Cole, Alicja Gorecka, Isabelle Haik, Sabine Iatridou, Kyle Johnson, Betsy Klipple, Dinette Massam, Kate Mc Creight Young, Janis Melvold, Nancy Peters, Tova Rapoport, Betsy Ritter, Marc Ryser, Doug Saddy, Danilo Salamanca, Michelle Sigler, Carol Tenny, Loren Trigo, and Corey Washington. Thanks to them my experience at MIT has been less difficult. I want to apologize for my shyness, which has been a thorn in my side.

I thank my family: my father, my mother, my grand-parents. This thesis originates in that desire for life, that love for knowledge and freedom that they gave me.

And last, but not least my gratitude and love to Lori, my wife. I cannot enumerate the reasons that I have for being grateful to her, because they are too many. I can only say that this thesis is also a fruit of her love. Grazie di cuore, Lori.

TABLE OF CONTENTS

ABSTRACT	2
ACKNOWLEDGMENTS	4
Chapter 1 A THEORY OF UG FILTERS	9
1.0 Introduction	9
1.1 UG filters	20
1.2 Vowel Harmony in Finnish and Akan	27
1.3 Pronunciation of foreign segments	43
1.4 Metaphony in southern Italian dialects	56
1.5 Disallowed configurations of features and the specifications of feature values	75
1.5.1 Brief excursus	77
1.6 The application of phonological rules and filters	78
1.7 Vowel Harmony in Ogori	83
1.8 Vowel Harmony in Paleo-Siberian languages	106
1.8.1 Koryak and Nez Perce	135
1.9 Surfacing of disallowed configurations of features	147
1.10 Okpe and Kwa languages	172
1.11 Romance languages	185
1.12 Against Structure Preservation	195
1.13 Two-vowel systems: the case of Kabardian	210
FOOTNOTES	234
Chapter 2 UNDERSPECIFICATION	246
2.1 A critique of Archangeli and Pulleyblank's Theory of Underspecification	246
2.2 Steriade's Theory of Underspecification	257
2.3 A Theory of Underspecification based upon UG filters	291
2.4 Underlyingly Absent distinctive values	324
2.5 Post-nasal voicing in Japanese	337
FOOTNOTES	343

Chapter 3	UG FILTERS AND AUXILIARY FILTERS	347
3.1	A tentative list of UG filters	348
3.2	Comments on the UG filters proposed in Sect. 1.	357
3.3	Auxiliary filters.	373
3.4	Auxiliary filters and the Theory of Underspecification	387
3.4.1	Appendix to Sect.4	404
3.5	Chain Shifts	412
	FOOTNOTES	422
Chapter 4	CLEAN UP RULES	436
4.1	Fission	436
4.2	Delinking	457
4.3	Negation	460
BIBLIOGRAPHY		466

CHAPTER 1

A THEORY OF UG FILTERS

0. INTRODUCTION.

Every linguist agrees that every language has an inventory of phonological segments used to distinguish lexical items in underlying representations. I will call the inventory of phonological segments of a language the phonological alphabet of that language. Each segment of the phonological alphabet of a given language is selected from the entire range of possible phonological segments, and the selection of the segments may vary according to the language. Thus, French has the front rounded vowels / \ddot{u} / and / \ddot{o} / in its phonological alphabet, whereas Italian does not.

Linguists agree that these phonological alphabets are organized along certain fundamental parameters. For example, vowel inventories are organized along the parameters of height and backness intersected by rounding, length, nasalization, etc. But vowel inventories are not constructed by simply randomly choosing items along these parameters: some vowel inventories are apparently impossible, others common, and yet others rare. All seem to be built according to certain basic criteria.

Every linguist also agrees that any adequate grammar must have a formal means to describe the structure and the properties of phonological alphabets.

In Generative Phonology, various proposals have been made in this regard (cf. Halle (1962), Stanley (1967), Chomsky and Halle (1968), Stampe (1972), Kiparsky (1981), (1985) among many others). There is, however, no established agreement regarding the formal means that should be used. In this thesis, I will take my stand on this issue and I will propose a formal means to represent the structure and the properties of phonological alphabets. I will argue that this formal means consists of negative conditions on the cooccurrence of features, similar to those originally proposed by Stanley (1967) and adopted by Kiparsky (1981), (1985). A negative condition on feature cooccurrence (which I will call a filter) has the following form where aF1,..., bF2 represent feature values:

$$(1) \quad *[aF1, \dots, bF2] \quad (a, b = +/-)$$

(1) represents the fact that the feature values aF1 and bF2, ..., cannot cooccur in the same feature bundle. Therefore, if a filter like (1) holds in a phonological system, a feature bundle that contains the configuration of feature values aF1, bF2, ..., is disallowed in this system. Thus, the segment or the class of segments which is peculiarly defined by the presence of the feature values aF1, bF2, ..., in its feature bundle is missing in this system since its feature bundle is disallowed. I also assume that if a segment or class of segments is missing in a segmental system, this means that a filter like (1), which disallows the configuration of feature values peculiar to this segment or class of segments, holds in this system. Therefore, I assume that there is a

biunivocal correspondence between the absence of a segment or class of segments from a phonological system and the presence of a given filter in this system. For example, consider Italian. In the Italian vowel system, there is no front low vowel. According to what I have said, this means that the filter in (2) holds in the phonological system of Italian:

(2) *[+low, -back]

(2) states that the feature values [+low] and [-back] cannot cooccur in the same feature bundle in Italian. Therefore, the feature bundle of the front low vowels that contains the configuration [+low, -back] is disallowed in Italian.

I propose that there is a set of filters provided by Universal Grammar, which I call UG filters. I propose that UG filters are hierarchically ordered: the more complex a phonological segment is, the higher the filter that excludes it is in the hierarchy. I assume that more complex segments are less frequent in phonological alphabets across languages. Therefore the hierarchy also reflects the frequency of segments across languages. The hierarchy of UG filters is also intended to capture Jakobson's (1941) observations on language learning and loss, as well his observations on the universal implications about the structure of phonological alphabets. I will demonstrate that hierarchically ordered UG filters are needed to represent generalizations on phonological alphabets.

I propose that Universal Grammar provides a set of rules which

function to repair configurations of features that violate filters. I will call these rules clean up rules. By hypothesizing an interaction among phonological rules, filters and clean up rules, I account for several phonological phenomena in a straightforward way. I show that it is possible to explain certain cases of phonological variation by hypothesizing that a given disallowed configuration of features may be repaired by different possible clean up rules.

I propose a Theory of Underspecification based upon UG filters. The central idea of the Theory of Underspecification is that not all of the feature values characterizing a segment are phonologically relevant and that the phonologically irrelevant feature values are underlyingly unspecified. It is assumed that the features which are phonologically irrelevant in a feature bundle are those features that can be predicted given the presence of other features in that feature bundle. I argue that the UG filters needed to describe the structure of a given phonological alphabet determine what features are underlyingly specified or unspecified in the feature bundles of that phonological alphabet. In this way, the Theory of Underspecification is tied to the theory of phonological alphabets in a crucial way.

I argue that language-specific filters are needed in addition to the UG filters in order to account for the structure of phonological alphabets. These language specific filters may be acquired only through negative evidence and have a very marginal phonological status. I show that they do not play a role in the Theory of Underspecification. This provides further evidence in support of the

hypothesis that the Theory of Underspecification must be based only upon UG filters

This thesis is written in the framework of non-linear phonology. For readers not familiar with this approach, I will give a brief summary of it and refer those interested to the literature for a more exhaustive account (cf. Goldsmith (1976), Steriade (1982), (1983), Halle (1986), Halle and Vergnaud (1980), Levin (1985) among others). In the model of Chomsky and Halle (1968), the phonological representation is unilinear, i.e., it consists of a single sequence of segments and boundary symbols where the segments are composed of linearly unordered sets of features. The study of tone languages, however, led linguists like Williams and Goldsmith to more complex representations. They proposed that certain distinctive features are represented on tiers which are separate from, and run parallel to the string of segments (cf. Williams 1976, Goldsmith 1976). Thus, in (3) tonal features are represented on the tone tier, and segments receive tone specifications by being associated with tones - where association is represented by drawing a vertical line between the segment and the tone.

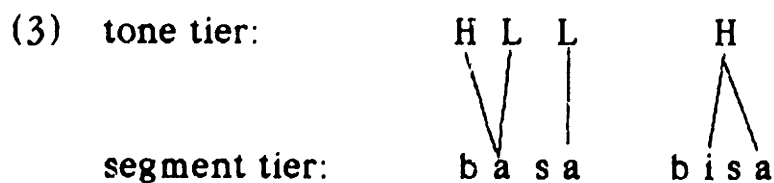

Observe that in (3) the tones do not need a one-to-one correspondence with the segment. That is, there can be different kinds of associations between tones and segments, e.g., one tone can be associated with two

segments, and one segment with two tones, as in (3). This proposal of multi-tiered representations represented the starting point of non-linear phonology.

The crucial point in this approach is that distinctive features behave as autonomous objects in phonological representations as indicated by the fact that they can have their own tier. This means that they are independent of the feature matrices and therefore that they can be manipulated by phonological rules independently of the other features in the matrix. This need for multi-tiered representations leads to representations that have a three-dimensional structure, in which we find not just one sequence of segments, but several sequences geometrically organized in the three dimensions of space. These three-dimensional representations consist of a number of half-planes, all of which intersect in a central line made up of a sequence of timing units, X-slots. Some of the half-planes in a non-linear representation are the syllable structure plane, the stress plane and the segmental melody plane, as can be seen in (4) with a partial representation of the Italian word 'frutto':

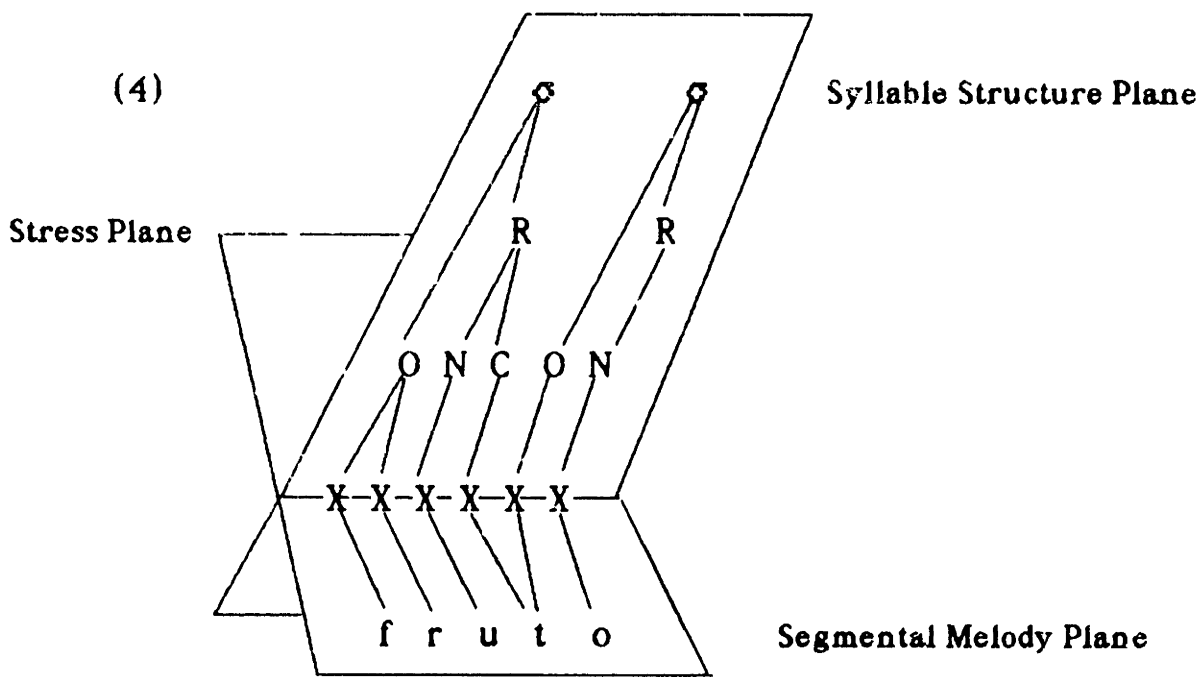

Developments of this model (cf. Clements (1985), Halle (1986), Sagey (1986)) have shown that phonological segments must be analyzed as being composed of a timing slot and a melody containing all the distinctive features that are peculiar to this segment. These features are represented on distinct tiers or planes which are associated with a single root node. This root node with all the feature planes it dominates characterizes the phonological segment. The root node is linked to one of the timing units lacking phonological or phonetic properties represented by the sequences of *x* that compose the core skeleton. A timing unit together with all the distinctive features which are linked to it represents a phoneme. The distinctive features are hierarchically ordered into a feature tree. The terminal nodes are all articulatory features. The terminal nodes are further grouped together under various class nodes. Following Sagey (1986), Halle (1987), the tree is organised as in (5):

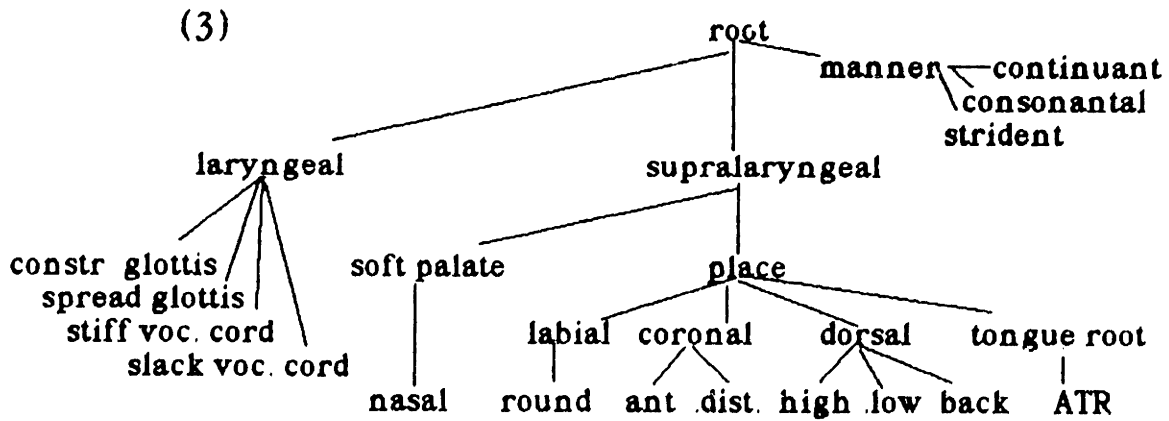

The correct way of representing the tree in (5) is to imagine it as a three-dimensional structure like that in (4). Each terminal node is linked to skeletal positions (via intermediate class nodes) on its own plane, and there is a plane corresponding to every terminal node in the feature tree. In this way, the feature tree in (5) appears to be most properly a set of half-planes intersecting with each other. A sequence of three skeletal slots together with the feature trees that are linked to them should therefore be represented:

(7)

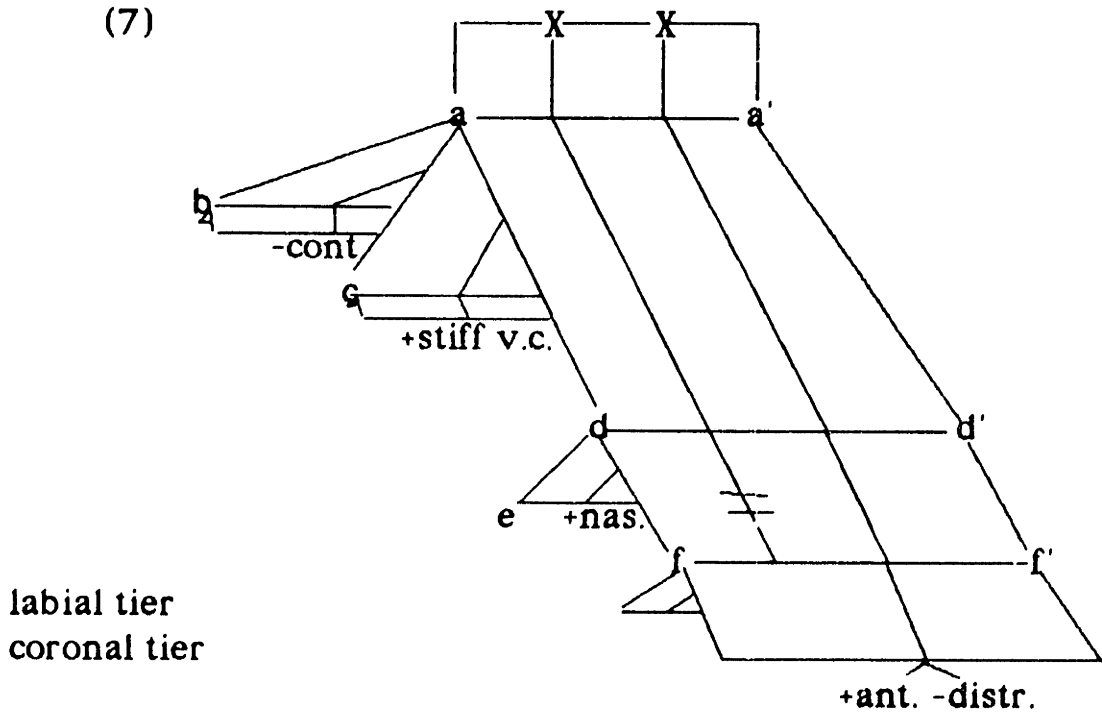

With representations like these any node may act as an independent object, linking and delinking from skeletal positions independently of the linkings between the other nodes and the skeleton. For reasons of graphical simplicity, three-dimensional representations like those in (4), (6) and (7) are not used. They are instead transformed into bidimensional representations like that in (8) which corresponds to (7), but with the difference that every node is seen from the perspective of looking down the axis of the skeletal core:

(8)

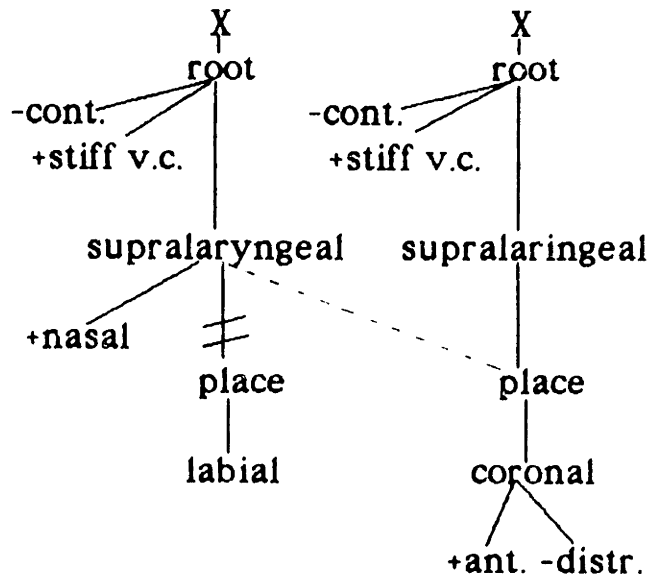

This is the type of representations that will be used in this thesis. Observe that simplified representations will be used where intermediate class nodes are omitted if they are not independently needed

1. UG FILTERS

In this chapter, I will argue that filters are needed in order to have an explanatory analysis of several phonological phenomena.

In this section, I shall show that generalizations about the structure of phonological alphabets must be formally represented with negative conditions that constrain feature cooccurrence.

I propose that there is a set of filters provided by Universal Grammar and that only these filters are possible in a given language (see Chapter 3 for a modification of this proposal). I will call these filters UG filters.

I assume that the UG filters are hierarchically ordered. The more complex a phonological segment is, the higher the filter that excludes it is in the hierarchy. I assume that more complex segments are less frequent in phonological systems across languages. Therefore the hierarchy reflects also the frequency of segments across languages. The hierarchy of UG filters is also intended to capture Jakobson (1941)'s observations on language learning and loss, as well as his observations on the universal implications about the structure of possible phonological systems. My idea is that a child can learn a segment violating a filter in a certain position in the hierarchy only after he learns a segment violating a filter in a lower position. In contrast, an aphasic loses a segment violating a filter in a higher position in the

hierarchy before he loses a segment violating a filter in a lower position. Another claim is that a segment disallowed by a filter at a higher position can be present in a phonological system only if a segment disallowed by a filter at a lower position is also present in that phonological system. In this way, I am able to account for the well known facts that the presence of mid-vowels presupposes the presence of high vowels in vowel systems and that the presence of voiced stops presupposes the presence of voiceless stops in consonantal systems.

I assume that a phonological system is maximally unmarked when no UG filter is violated. In the normal case, however, each particular language violates a subset of UG filters, i.e., its phonological system has a number of segments which violate these UG filters. The complement set of unviolated UG filters defines the shape and the structure of the phonological system of that particular language. I will call these unviolated UG filters underlying filters of that language.

I propose that the markedness of a phonological system increases with the height in the hierarchy of the filter that the system violates, and I want to suggest that a UG filter can be violated only if all filters lower in the hierarchy are violated.

I propose the set of UG filters in (1) for vocalic systems (in Section 12 of this Chapter and in Section 3 of Chapter 2, I will introduce other two filters to this hierarchy):

Observe that the ranking is given only by numbers and not letters. Therefore, (V)a) and b) have the same hierarchical position.

(1)

- VIII) * [+low, +high]
- VII) * [-conson., +nasal]
- VI) a) * [+back, -round] / [____ , -low] b) * [+low,+ATR]
- V) a) * [-back, +round] b) * [+high, -ATR]
- IV) * [+low,+round]
- III) * [-high, +ATR]
- II) * [+low, -back]
- I) * [-high, -low]

With the upside down ranking of (1), I intend to capture the relation between numerical height and spatial height so that no confusion in the use of the terms high and low is created. Observe also that the ordering in (1) is a tentative one and that it is subject to modifications based on empirical grounds.

Most unmarked is the three vowel system in (2) where all the UG filters in (1) are respected; in this vocalic system, the set of underlying filters corresponds to the set of all UG filters.

- (2) i u
 a

A language with a five vowel system as in (3) violates only the UG filter (1) I); in this vocalic system, the set of the underlying filters contains the UG filters from (II) to (VIII).

(5) i u
 ε o
 a

This means that a phonological system is learned only through positive evidence: if a child encounters a certain segment in his or her learning process, then he or she learns that the UG filter that blocks that segment is violated. The absence of a segment does not lead to a new filter. There is no learning based on negative evidence. (In Chapter 3, a slightly different hypothesis will be proposed to account for segments that are actually absent in a phonological system, but should be present, given the UG filters that are underlyingly violated in this system, i.e., to account for the missing /e/ in a vowel system that contains only the vowels / i, u, o, a/.).

Let us suppose that all features may be combined freely. For each phonological system, the underlying filters of this system will "filter out" some of these combinations of features. The combinations that are not "filtered out" make up the feature bundles allowed in this system. Thus, for example, consider the vowel system in (4); all the UG filters in (1) are underlying filters of this vowel system. Therefore, the only combinations of features that are allowed in (1) are those in (4):

(4)	+low	-low	-low
	-high	+high	+high
	-ATR	+ATR	+ATR
	+back	-back	+back
	-round	-round	+round

These are precisely the feature bundles of /a/, /i/ and /u/.

Stanley (1967) proposed that another formalism could also be used to represent generalizations about sound systems, an if-then condition. Hyman (1975), following Schachter and Fromkin (1968), argues that negative conditions are not needed since they can always be restated as if-then conditions. Thus, for example, the negative condition *[+low, -back] could be restated as the if-then condition in (5):

(5) if: [+low]
 then: [+back]

(5) states that a feature bundle that contains the feature value [+low] must also contain the feature value [+back]. I do not agree with Hyman. I believe, in contrast, that only negative conditions are needed to represent the structure of vowel systems. Observe that whereas the emphasis of negative conditions is on the configurations of feature that are disallowed in a system, the emphasis of if-then conditions is on the configurations of features that must occur in the same feature bundle. As I said above, by assuming that negative conditions "filter out"

configurations of freely combined features, we obtain the fact that only certain features can cooccur in the same feature bundle in a given system. Therefore, if-then conditions can also be derived from negative conditions. In the next sections, I will argue that the notion of disallowed configuration of features is of crucial importance in the treatment of several phonological phenomena: phonological rules can be prevented from applying if their application would produce disallowed configurations of features; disallowed configurations of features found in foreign sounds are repaired in a limited number of ways; disallowed configurations of features produced by application of phonological rules in the case in which they are not blocked are also repaired in the same limited number of ways.

Now, a condition like that in (5) also predicts that a configuration of features [+low, -back] is disallowed in Italian. This is a consequence of the fact that according to (6), the presence of the feature value [+low] implies the presence of the feature value [+back] in the same feature bundle. This is not what happens if the configuration [+low, -back] is contained in the same feature bundle. Therefore this configuration is disallowed. In this way, a crucial role is given to the configuration [+low, +back] in explaining the "agrammaticality" of [+low, -back] in Italian. Now, it can be shown that this configuration [+low, +back] does not play any role in Italian in disallowing the configuration [+low, -back]. Consider the Italian pronunciation of English /æ/, which has the configuration [+low, -back] disallowed in Italian. Now /æ/ can be pronounced either as [ɛ] or as [a] by an Italian speaker. Thus, English

/kæt/ 'cat' can be pronounced either [ket] or [kat] by an Italian speaker. In Section 3, I will account for this fact by hypothesizing that whenever a speaker has to deal with a configuration of features disallowed by a filter in his/her own language, he/she has access to a series of rules that repair this disallowed configuration. One of these rules is delinking, which has the effect of changing the value of one of the features of the disallowed configuration into its opposite. This is the rule that appears to be working in the Italian pronunciation of English /æ/: the configuration [+low, -back], which is disallowed in Italian, is repaired either as [+low, +back] or as [-low, -back]. Now, if it were true that the configuration [+low, -back] is disallowed in Italian because the if-then condition (6) is active in this language, we should expect that delinking of [-back] which produces the configuration [+low,+back] be the normal repair of the disallowed [+low, -back] since this is the configuration predicted as correct by the implication in (6). But this is not what actually happens. The repair can produce both [-low,-back] and [+low, +back]. This is what a negative condition like *[+low, -back] would predict: both [+low, +back] and [-low, -back] are equally allowed by this negative condition, and neither of them enjoys a preferential status according to it. It is for reasons like this that I believe that negative conditions must be preferred over if-then conditions.

In the next sections , I will attempt to show what is achieved in terms of simplification and explanatory power if filters are adopted as the correct formalism to represent generalizations about phonological systems.

In section 2, I will consider two cases of vowel harmony with neutral vowels, i.e., vowels that can occur with both sets of harmonic vowels. The first case is that of Finnish, where we have transparent neutral vowels, i.e., neutral vowels that can be skipped by the harmony rule; the second case is that of Akan, where we have opaque neutral vowels, i.e., neutral vowels that cannot be skipped by the harmony rule. The properties of these vowel harmony systems can be easily accounted for if the analysis takes into consideration the underlying filters of these systems.

In section 3, I will consider the case of the pronunciation of foreign segments. I will show that the range of possible pronunciations of these segments can be accounted for if the underlying filters that block these segments in the phonological system of the speaker are considered.

In section 4, I will show that by taking into consideration the underlying filters that define the structure of a phonological system, it is possible to account for the peculiar phonological phenomena of several languages where there is a phonological rule whose outputs violate underlying filters.

2. VOWEL HARMONY IN FINNISH AND AKAN.

In this section, I will analyze the behavior of neutral vowels in the harmony systems of Finnish and Akan and show how the properties

of these vowels can be accounted for by taking into consideration the underlying filters that hold in the vowel systems of these two languages. The analysis that I propose here essentially follows the development of Kiparsky (1981)'s theory made by Cole and Trigo (1987) and Steriade (1987). I shall begin by discussing the vowel harmony of Finnish. Here, for reasons of simplicity, I will discuss only what would be the correct analysis of Finnish vowel harmony if only native words were taken into consideration. Therefore, I will not consider the case of non-native disharmonic words. In Chapter 2, I will present a more elaborate analysis of Finnish vowel harmony that takes into consideration also non-native disharmonic words.

Finnish has the following eight vowels (each vowel can be either long or short):

- (1)
- | | | |
|---|---|---|
| i | y | u |
| e | ö | o |
| ä | | a |

They have the following feature composition:

- (2)
- | | u | o | a | y | ö | ä | i | e |
|-------|---|---|---|---|---|---|---|---|
| back | + | + | + | - | - | - | - | - |
| round | + | + | - | + | + | - | - | - |
| high | + | - | - | + | - | - | + | - |
| low | - | - | + | - | - | + | - | - |

In the vowel system in (1), the UG filters 1.(1) I), II), III), V) are underlyingly violated. The remaining UG filters are not violated and therefore form the set of underlying filters. In particular, observe that in (1) the UG filter 1.(1) V_ia), which disallows nonlow unrounded back vowels, is in the set of underlying filters. I repeat this filter in (3):

(3) * [+back, -round] / [____, -low]

The vowel harmony of Finnish could be described by a constraint like the following:

(4) Front and back vowels do not co-occur in words.

However, (4) does not hold for vowels /i/ and /e/ which, although front, can cooccur with back vowels in the same word -- vowels that have this property are called neutral vowels in the literature. Therefore, (4) must be reformulated as (5):

(5) Non-neutral front and back vowels do not cooccur in words.

(5) is a constraint on stems, as we can see in (6a), and on combinations of stems and suffixes as we can see in (6b):

(6) a)	makkara	"sausage"
	vakkara	"pinwheel"
	palttina	"linen cloth"

varttina	"spinning wheel"
kaura	"oats"
kayra	"curve"
luo	"creates"
lyö	"hits"

b) palettina + lla + ni + han "with my linen cloth,
as you know"

varttina + lla + ni + han "with my spinning wheel,
as you know"

luo + da + kse + ni + ko "for me to create?"

lyö + dä + kse + ni + kö "for me to hit?"

In the forms in (6) we can observe that the neutral vowels /i/ and /e/ can occur both with back and non-back vowels in the same word without any problem. Stems containing only neutral vowels assign front harmony to their suffixes:

(7) meteli + llä + ni + han "with my nose , as you know"
vie + dä + kse + ni + kö "for me to bring away?"

Finnish vowel harmony can be characterized by a rule that makes non-neutral vowels back when preceded by back vowels. This does not present a problem. The most problematic aspect of the analysis is, instead, the treatment of neutral vowels. There are two important observations concerning neutral vowels that the analysis of Finnish vowel harmony must take into consideration. The first observation is

that the behavior of the neutral vowels /i/ and /e/ could be explained if the harmony rule can be prevented from applying to them, and if there is a way to represent the fact that the harmony rule skips them as if they were transparent. The other observation is that if the vowels /i/ and /e/ were targets of the harmony rule, they would be changed by that rule into the vowels /ɨ/ and /ʏ/, which are disallowed by the underlying filter in (1). If these two observations are combined, one can conclude that the explanation of the behavior of vowels /i/ and /e/ in the Finnish vowel harmony should be linked to the fact that the vowels /ɨ/ and /ʏ/ are disallowed by the underlying filter in (1): in fact it is possible to hypothesize that the vowel harmony rule is prevented from applying to vowels /i/ and /e/ precisely in order not to produce the disallowed vowels /ɨ/ and /ʏ/.

What we need to say is simply that an underlying filter has the property of blocking the spreading or the assignment of one of the features contained in the filter to a feature bundle that contains the other feature of the filter. Therefore, the underlying filter in (1) has the property of blocking the spreading or the assignment of the feature [+back] to [-low, -round] vowels. This explains why the vowels /i/ and /e/ do not undergo the harmony rule in Finnish. In fact, the application of the harmony rule to /i/ and /e/ is blocked by (7), since it would create the disallowed configuration [-low, -round, +back].^[1]

By assuming the underlying filter in (1) and hypothesizing that it can block the application of phonological rules, we can explain why the

harmony rule of Finnish does not apply to the vowels /i/ and /e/. However, we must also explain why the harmony rule can skip them without difficulty. This is what we are going to do now.

It is possible to hypothesize that the values of certain features are not underlyingly specified. Steriade (1987) argues that the pattern in which feature values are absent from underlying representations in a language L is determined simply by considering what are the distinctive and non-distinctive assignments of feature values in the phonological inventory of L. In particular, she proposes that the feature values that are systematically absent from the underlying representations of L are the feature values that have a non-distinctive assignment in L. Now distinctive and non-distinctive assignments of feature values in a phonological inventory are determined precisely by the underlying filters. Underlying filters establish that a certain feature value a^F is non-distinctive in a feature bundle containing other feature values by forbidding the occurrence of the distinctive value $-a$ of a^F in that feature bundle. Thus, for example in the case of the underlying filter in (3), [-back] is non distinctive in a feature bundle containing the feature values [-round, -low], since by (3) its distinctive value [+back] cannot occur in that feature bundle. We can therefore say that the feature value [-back] is underlyingly absent in feature bundles which contain the feature values [-round,-low] since it is non-distinctive, and that it is filled in in a later stage of the derivation by a redundancy rule like (8):

(8) [-round, -low] > [-back]

Steriade, following Kiparsky (1981), proposes also that the values that are the complements of the underlying feature values can be underlyingly absent. They will be filled in by a redundancy rule like the following:

(9) [] > -aF (where a is the underlying value for F)

She calls the value introduced by rules like (8) redundant values and the rules that introduce them R-rules. In addition, she calls the values introduced by rules like (9) distinctive values and the rules that introduce them D-rules. (In Chapter 2, a more detailed analysis and discussion of Steriade's theory will be given.)

Let us consider Finnish vowel harmony now. The behavior of the neutral vowels of Finnish is explained in the following way: given what was said before, filter (3) establishes not only that the feature value [+back] is impossible in a feature bundle that contains also [-round, -low] in Finnish, but also that the feature value [-back] is underlyingly absent in that environment. It will be filled in later by the R-rule in (8).

I assume then that [+back] is the underlying value for [back]. Therefore we can hypothesize the following D-rule for [back]:

(10) [] > [-back]

Thus, the feature value [-back] is underlyingly absent in Finnish.

The Finnish vowel system should then be underlyingly specified for backness as in (11) (I do not consider the pattern of underspecification for the other features here):

(11)		u	o	a	y	o	a	i	e
	back	+	+	+					
	round	+	+	-	-	-	-	-	-
	high	+	-	-	+	-	-	+	-
	low	-	-	+	-	-	+	-	-

Now, it is possible to assume that the stage at which the harmony rule applies in Finnish precedes the stage at which D-rule (10) and, in particular, R-rule (8) apply. Therefore, at the stage at which the harmony rule applies, the feature bundles of /y, o, a/ and, in particular, /i/ and /e/ have the value for [back] unspecified.

The harmony rule of Finnish must then be characterized as a rule which spreads the feature [+back] of a back vowel to the neighboring vowels filling in the values for [back] which are not underlyingly present:

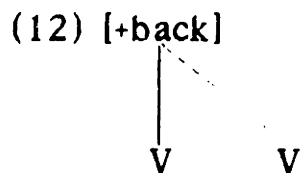

If the target of the harmony rule is one of the neutral vowels /i/ or /e/

In (15) the I's are still unspecified. After the application of (8) we will obtain (16), where all the vowels are specified:

(16) palltina + lla + ni + han

(16) is the correct form.

Let us consider now värttinällanihan. The underlying form is the following:

(17) v A r t t I n A + l l A + n I + h A n

In (17) there is no vocalic segment associated with [+back]. Therefore there is no [+back] to be spread. Thus we obtain the right form in (18) by introducing R-values through the application of (8) and D-values through the application of (10):

(18) v_{-b.} a_{-b.} r_{-b.} t_{-b.} t_{-b.} i_{-b.} n_{-b.} ä_{-b.} + l_{-b.} l_{-b.} a_{-b.} + n_{-b.} i_{-b.} + h_{-b.} a_{-b.} n_{-b.}

In the case of a word with only neutral vowels, we have the same situation as we had in (16):

(19) m E t E I I + l l A + n I + h A n

In (19), there is no [+back] to be spread. Therefore the R-values will be

inserted by (8) and the D-values by (10).

Therefore the proposal that phonological representations can be unspecified at certain stages of the derivation, in conjunction with the idea that the underlying filters can block the assignment of a feature to a feature bundle, allows a straightforward analysis of the transparent neutral vowels in the vowel harmony system of Finnish.

The same analysis can be used to account for the vowel harmony system of Akan, a West African language of the Kwa family, where instead of transparent neutral vowels, we have an opaque neutral vowel, i.e., a vowel which does not undergo the harmony rule, but which cannot be skipped by it .

Phonemically, Akan has nine vowels, grouped into two sets according to their specification for the feature [Advanced Tongue Root]:

(20)	i	u	ɪ	ʊ
	e	o	ɛ	ɔ
			a	
	[+ATR]		[-ATR]	

In the vowel system in (20), the UG filters 1.(1)I), III), V)b) are underlyingly violated. The remaining UG filters are therefore the underlying filters of the Akan vowel system. The underlying filter that will be of crucial importance in the analysis of the Akan harmony

system proposed here is 1.(1) VI) b). I repeat it as (21):

(21) * [+low, +ATR]

(21) states that the feature values [+ATR] and [+low] cannot cooccur in the same feature bundle. (21) therefore disallows [+ATR] low vowels in the phonological system of Akan.

Let us now consider the harmony system of Akan. In words which do not contain low vowels, all vowels must be either [+ATR] or [-ATR], e.g. e-bu-o 'nest', e-bu-ɔ 'stone'. The low vowel /a/ co-occurs with either set of vowels, e.g. bisa 'to ask', pira 'to sweep'. Moreover, vowels of the two sets freely co-occur if /a/ intervenes, e.g. fupani 'to search', and otherwise rarely cooccur, e.g. pinseɲ 'to be pregnant'. Prefix and suffix harmony are controlled by the first and last root vowel, respectively, e.g. o-bisa-l 'he asked (if)'; o-pinseɲ-l 'she became pregnant'.

The underlying filter in (21) also establishes that the feature value [-ATR] is non-distinctive in a feature bundle which contains the feature value [+low]. Therefore, it is underlyingly absent and must be introduced by the following R-rule:

(22) [+low] --> [-ATR]

The feature value [+ATR] is considered to be underlying.

Therefore we can hypothesize the following D-rule:

(23) [] --> [-ATR]

The vowel harmony rule is then formulated as in (24):

(24) +ATR
|
V1 V2 V1 and V2 must be in adjacent syllables

I assume that rule (24) applies iteratively.

The crucial constraint in (24) is that the trigger and the target of rule (24) must be in adjacent syllables. If the requirement of adjacency is violated, the rule cannot apply.

It is possible to assume that the Akan affixes are inherently unspecified for the feature [ATR]. Therefore, the feature [+ATR] is spread in order to fill in the unspecified values for [ATR]. If there is no spreading of [+ATR], the unspecified values are filled in with the feature value [-ATR] by rule (23).

In assuming that (21) blocks the spreading of [+ATR] to a low vowel, it is possible to explain the facts of vowel harmony in Akan. The feature cooccurrence constraint (21) prohibits the feature value [+ATR] from latching onto the feature bundle of /a/. Therefore /a/ cannot be a target of the rule. At the same time, the adjacency requirement of (24)

states that a vowel which is in a syllable separated from the trigger of the harmony rule by a syllable containing /a/ will not be able to be a target of the spreading, since it is not in a syllable adjacent to the syllable containing the trigger of the rule. Therefore, /a/ is the opaque vowel of the harmony system of Akan. Given that it cannot be associated with [+ATR], it may occur freely with the two sets of vowels in (20) and will block spreading of the harmonic value. Thus in the following word:

(25) [+ATR]
 |
 funan -ɔ

the presence of /a/ in the middle syllable impedes the spreading of [+ATR] to the last vowel, which is then specified as [-ATR] by the D-rule (23).

In this section, a very restrictive and explanatory theory of neutral vowels has been proposed. I have assumed that the structure of a phonological system is determined by a set of underlying filters, a subset of the UG filter set, which define the segments or class of segments that are absent in that system. I then assumed that these filters can block the application of a phonological rule to a feature bundle if the application of this rule to the feature bundle creates a violation of an underlying filter. These two assumptions account for the phenomenon of neutral vowels: a vowel is neutral in a vowel harmony system if the application of the vowel harmony rule to it creates a

violation of a filter. Because of this, the application of the vowel harmony rule to that vowel is blocked. Opacity and transparency of neutral vowels are accounted for by assuming that the redundant values of these vowels are unspecified, and that there can be a prosodic locality constraint on the application of the harmony rule which states that the trigger and the target of the harmony rule must be in adjacent syllables. If the harmony rule is limited by this constraint, we have a harmony system with opaque neutral vowels. If there is no such constraint on the rule, we have a harmony system with transparent neutral vowels.

In this theory, no stipulations on neutral vowels are needed and the explanation of their behavior is derived on independent grounds. Observe, however, that there is no real motivation for using filters in this approach. We could assume that there are no static conditions -- like the filters -- that define the structure of a phonological system by disallowing certain configurations of features and allowing certain others as was assumed here. Instead, there would be only the R-rules of the theory of underspecification, and one of the functions of these rules would be to establish which configurations of features are allowed and which are disallowed. This could be done very easily in the following way. In the theory of underspecification, the fact that certain feature values must always cooccur in the same feature bundle can be expressed by stating that some of these values are underlyingly unspecified and that there are R-rules like that of (26) which specify them:

(26) [aF1] --> [bF2]

(26) not only says that [bF2] is underlyingly unspecified, but also that it always occurs in a feature bundle that contains [aF1].

In the preceding pages, I have proposed that an R-rule like that in (26) is correlated to the presence of a filter that constrains the cooccurrence of [aF1] and [-bF2] in the same feature bundle. In the interpretation of (26) given here, instead, the fact that [aF1] and [-bF2] cannot cooccur in the same feature bundle is correlated to the fact that only the feature value [bF2] can occur in a feature bundle that contains [aF1]. There is therefore a complete reversal of perspective. The structure of a vowel system is no longer defined by negative conditions that block the cooccurrence of certain features, but rather by positive rules that state that certain features must always cooccur with other features. In this way, the lack of non-low non-round back vowels in Finnish would be explained by the fact that non-low non-round vowels are always front in Finnish. The lack of a low [ATR] vowel in Akan would be explained by the fact that low vowels are always [-ATR] in this language. In other words, the structure of the vowel systems of these two languages would be determined by R-rules like the following:

(27) [-low, -round] --> [-back]

(28) [+low] --> [-ATR]

The properties of neutral vowels would be easily explained in this framework by assuming that the vowel harmony rule applies before

the R-rules in (27)-(28) apply, and by assuming that the redundant values can be filled in only by an R-rule. In this way, we obtain the fact that the harmony rule cannot apply to neutral vowels: the feature value spread by the harmony rule is redundant in the feature bundle of the neutral vowels. Therefore it cannot be assigned to this feature bundle by the harmony rule, but only by the appropriate R-rule. Opacity is then obtained in the same way as before by assuming that there can be a prosodic constraint of locality on the application of the harmony rule.

In the next sections, I will attempt to demonstrate that we need to use filters to define the structure of a phonological system, and that we would not be able to account for several phonological phenomena by using only R-rules like those in (27) - (28).

3. PRONUNCIATION OF FOREIGN SEGMENTS.

In the preceding section, we have seen cases in which underlying filters are used to prevent phonological rules from assigning certain values to features in given feature bundles by blocking the application of these rules.

In Calabrese (1986), I individuated a different function of underlying filters. In that paper, I observed that underlying filters also have the function of preventing the surfacing of configurations of features they disallow by triggering a series of rules that repair these

configuration.^[2] These disallowed configurations of features may be created in the course of the phonological derivation, as we will see in Section 5, or may occur when speakers deal with phonological systems different from their own. I shall begin by considering this last case.

Let us consider the way in which a speaker of a certain language attempts to pronounce a sound that is not present in his language.^[3] Excluding the rare case in which he pronounces it correctly, he usually replaces that sound with a similar sound in his language. Interestingly, the original sound can be replaced only in a limited number of ways.

Let us consider Italian. Italian has the following vowel system:

(1)	i	u
	e	o
	ɛ	ɔ
	a	

(This is the system of standard Italian. In other varieties of Italian, there are no mid [+ATR] vowels)

Observe that there are no front rounded vowels in this vowel system. In the approach with negative conditions like filters, this fact implies that the UG filter 1.(1)V) (here repeated as (2)) is an underlying filter in Italian:

(2) *[-back, +round]

(2) states that the feature [-back] and [+round] cannot cooccur in the same feature bundle in the phonological system of Italian.

In the approach in which there are no negative conditions like filters and in which only R-rules are used, the lack of front rounded vowels in Italian is a consequence of the fact that there are only front unrounded vowels and back rounded vowels in this language. This is explained by hypothesizing that one of the following R-rules holds in Italian:

(3) [αback, -low] --> [αround]

(4) [αround, -low] --> [αback]

(3) states that a feature bundle that contains the feature value [αback] and [-low] must also contain the feature value [αround]. In contrast, (4) states that a feature bundle that contains the feature value [αround] and [-low] must also contain the feature value [αback]. Observe that (3) and (4) cannot coexist in the same system, since they lead to opposite predictions. Therefore either (3) or (4) must hold in Italian, but not both.

Now, let us consider the Italian pronunciation of the German front rounded vowel /ü/. An Italian speaker usually cannot pronounce this vowel and replaces it with the vowels [i], [u] or, more commonly, with the diphthong [iu]. No other replacement is possible in this case. Thus, for example, the German word /fö:rer/'führer' may be pronounced as [firer], [furer], [fiurer]. My proposal is that this is not accidental, but

that there is a principled explanation for it.

In the following pages, I will discuss the solution that I propose for the different pronunciations of German /ü/ within the framework that adopts filters. Then I will show that it is not possible to account for these different pronunciations within the framework that uses only R-rules without using filters.

I hypothesize that the underlying filter in (2) not only blocks the configuration of features peculiar to /ü/, but also triggers a certain number of strategies which repair the disallowed configuration of features. I therefore assume that whenever a speaker must deal with a configuration of features which is disallowed by a filter, the configuration must be repaired in some way.^[4] I hypothesize that UG provides a set of strategies which have the function of repairing this disallowed configuration. I propose that the possible pronunciations of the German front rounded vowel / ü / by Italian speakers are examples of applications of these strategies. I will call these strategies clean up rules.

I propose that there are essentially three kinds of clean up rules. One is fission [5], by which the feature bundle containing two features incompatible because of a filter is broken into two feature bundles, each of which contains only one of the incompatible features. Another one is delinking, by which one of the incompatible features is delinked and replaced with a compatible feature. The third clean up rule is negation, by which the values of the incompatible features are negated

and thus changed into their opposites. (See Chapter 4 for a more extensive discussion of these strategies).

Let us begin with the fission rule. The existence of a phenomenon like fission has been recognized by several linguists, cf. for example Trubetzkoy (1969), Kiparsky (1973), Krohn (1975), Andersen (1970). While discussing the pronunciation of foreign sounds, Trubetzkoy observes the following: *"Whenever we hear a sound in a foreign language which does not occur in our mother tongue, we tend to interpret it as a sound sequence and to regard it as the realization of a combination of phonemes of our mother tongue. Very often the sound perceived gives reason for doing this since every sound is a sequence of "sound atoms". The aspirates actually consist of occlusion, plosion, and aspiration; the affricates of occlusion and friction. It is therefore not surprising if a foreigner in whose mother tongue these sounds are not present, or where they are not considered monophonemic, regards them as realizations of phoneme sequences. Likewise, it is quite natural that speakers of Russian and Czech consider the English vowels, regarded as clearly monophonemic by English speakers, as diphthong, that is, as combinations of two vowel phonemes. For these vowels are actually "diphthong of movement". But the polyphonemic interpretation of foreign sounds is very often based on a delusion: different articulatory properties, which in reality occur simultaneously, are perceived as occurring in succession. [emphasis mine. A.C.] Speakers of Bulgarian interpret German ü as iu ("juber" - "über" [over]), etc. They perceive the frontal position of the tongue and the protraction of the lips, which in German occur simultaneously, as*

separate stages." (Trubetzkoy (1969, pp. 63-64)). No linguist, however, has analyzed fission in explicit terms. This is what I attempt to do here. I assume that fission is essentially a rule that cleans up a configuration of features disallowed by a filter by matching each feature of that configuration with the value of the other feature required by the filter. This is obtained in the following way: the feature bundle that contains the configuration of features disallowed by the filter is split into two copies different only in the features that compose the disallowed configuration. In fact, each copy contains one of the features of the disallowed configuration C matched with the opposite value of the other feature of C. This process does not affect the timing slot associated with the feature bundle that contained the disallowed configuration. I formalize fission in the following way: (I do not represent the internal structure of the feature bundles in order to preserve the abstractness of the rule. Therefore the feature value aF1...dF4 that I use must be actually considered nodes in the feature tree.)

(5)

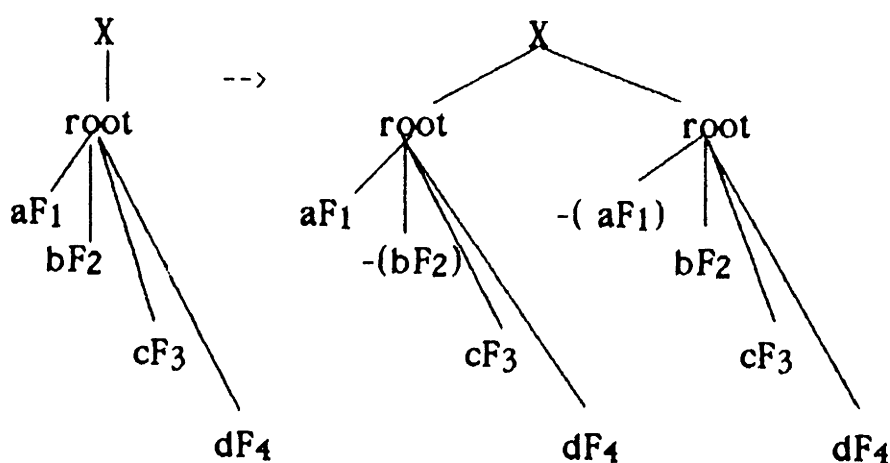

where the feature bundle on the left of the arrow contains the configuration of features [aF1, bF2] disallowed by the filter *[aF1, bF2] (a,b, c, d =+/-).

I will discuss the problem of the linear order of the two copies in Chapter 4 .

I assume then that the output of (5) is automatically simplified by a rule that merges adjacent identical nodes when dominated by the same timing unit. (I will not discuss the relation between this rule and the Obligatory Contour Principle (OCP) here.(For a discussion of the OCP, see McCarthy (1986))) In this way, the output of (5) will automatically be changed into (6):

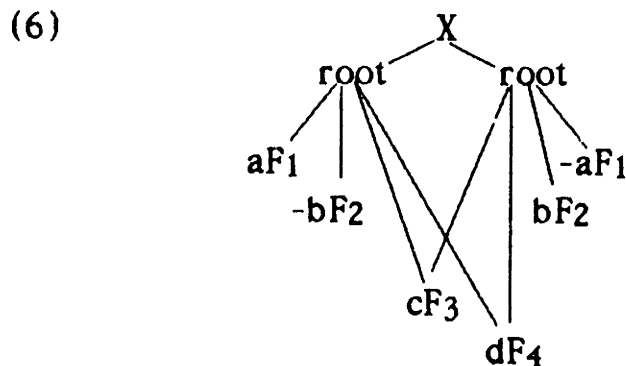

Given the automatic character of the rule that produces (6), I shall omit the intermediate stage in (5) and consider (6) as the final output of fission for the remainder of this thesis.

I assume that (6) is a contour segment. Therefore, I assume that the representation of contour segments with a branching root node proposed by Clements (1987) (see also Clements and Keyser (1983) for a similar proposal) is correct. I thus disagree with Sagey (1986)'s proposal that contour segments must be represented only through

branching of terminal nodes. I will argue more thoroughly for the hypothesis that the output of fission is that in (6) in Chapter 4. For now, observe that my reason to formulate the output of fission as in (6) is the following: the peculiarity of fission is that one feature bundle with a configuration of features disallowed by a filter is split into two feature bundles with configurations that are allowed by this filter, where by definition a feature bundle is a set of features dominated by a root node. We need to obtain two feature bundles, since a filter is sensitive only to cooccurrence of features in the same feature bundle. Now, a contour segment like that in (6) would be represented in Sagey's approach with only one root node and two branching terminal nodes. Therefore, we would have only one feature bundle, and the filter would then still be violated.

Delinking is a much less problematic clean up strategy. I define delinking as a rule that delinks one of the features blocked by a filter. The delinked feature is then replaced with its opposite value. I represent this in (7):

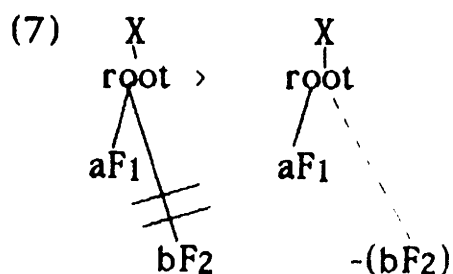

where aF_1 conflicts with bF_2 because of the filter $*[aF_1, bF_2]$
 $(a, b = +/-)$

The negation rule is more problematic. I assume that the negation rule is a rule which negates the feature values conflicting because of a filter, so that each feature comes out with its opposite value. This rule is represented in (8):

$$(8) \quad [aF_1, bF_2] \rightarrow - ([aF_1, bF_2]) \rightarrow [-aF_1, -bF_2]$$

where aF1 and bF2 are conflicting feature values because of the filter *[aF1, bF2] (a,b = +/-)

Thus, given a configuration where [-F1] and [+F2] are conflicting feature values because of a filter, (8) will yield the clean up in (9):

$$(9) \quad [-F_1, +F_2] \rightarrow - ([-F_1, +F_2]) \rightarrow [+F_1, -F_2]$$

As we shall see, negation seems to be triggered only by filters containing features representing vocalic height. I will discuss this constraint in Chapter 4.

Delinking could also be considered to be a rule that operates in just one step by changing the value of one of the incompatible features into its opposite value. In this sense, it would be a case of negation applied to just one of the incompatible features, instead of to all of them. However, I prefer to distinguish delinking from negation for the following reason: whereas negation seems to be triggered only by filters containing features representing vocalic height, delinking is not constrained in this way. I will discuss this further in Chapter 4.

Let us go back to the Italian pronunciation of the German front rounded vowel / ü /. (2) states that the features [+round] and [-back] cannot cooccur in the same feature bundle in Italian. This means that for an Italian speaker, the German phoneme / ü / has the disallowed configuration of features [+round, -back]. The solution that the Italian speaker provides to this problem is usually the diphthong [iu]. In this case, a German word like führer would be pronounced [fiurer]. This means that the disallowed configuration with two incompatible features [+round], [-back] is cleaned up by the application of fission. Thus, we have the derivation in (10):

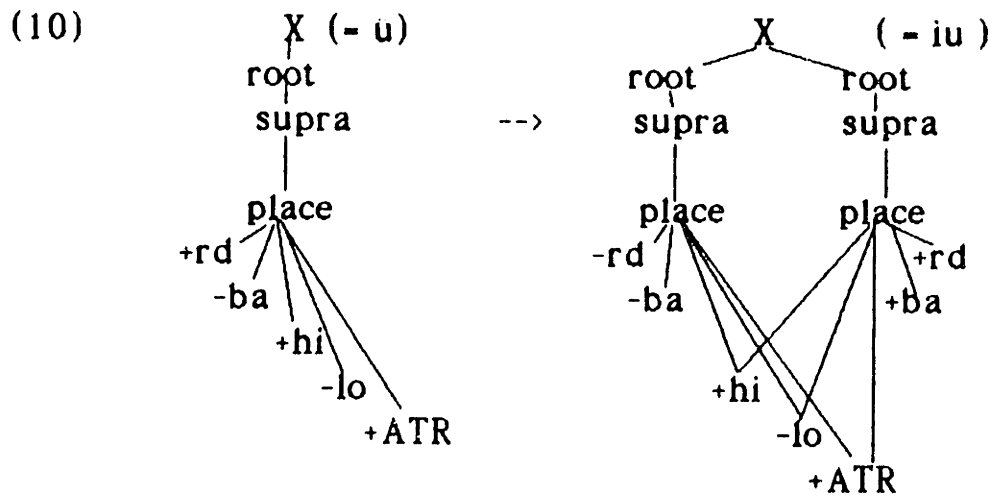

With (10), we can explain how we get the Italian [iu] from the German /ü/.

However, as I mentioned earlier, there are two other possible pronunciations of the German front rounded /ü/. One is [i] and the other [u]. Thus, the word führer can be also pronounced as [firer] or [furer]. These two cases are obtained by applying delinking to one of

the incompatible feature values as the clean up strategy. In the first case, the feature [+round] is delinked and replaced by [-round] so that we get the feature bundle in (11):

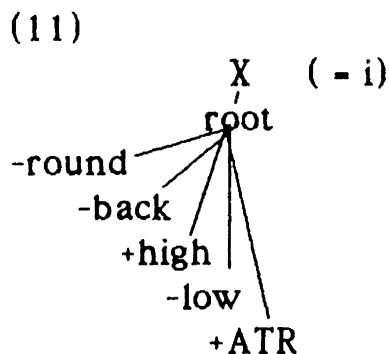

In the second case, the feature [-back] is delinked and replaced by [+back] so that we get the feature bundle in (12):

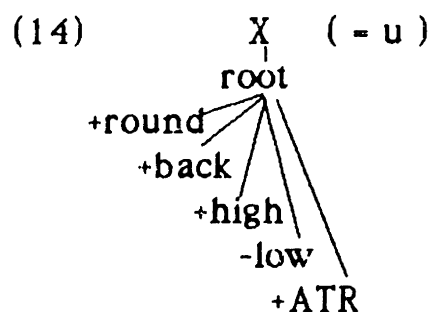

I suppose that all three forms /fiurer, firer, furer/ are available to the speaker, and that the choice of one of them in the phonetic performance is purely arbitrary. In the history of a language, it happens that only one of the forms derivable by the clean up rules is grammaticalized as the lexical norm. When this occurs, the loan word is apparently cleaned up by only one rule. I will discuss this further in section 4.

In the preceding cases we have not seen an application of the rule

of negation. The explanation for this is that the filter *[+round, -back] is composed of features that do not represent vocalic height and, as I said earlier, negation applies only when the triggering filter is composed of such features. However, we will see several applications of this rule in the next sections.

Let us consider now how the different pronunciation of German /u/ would be accounted for within the framework that has only R-rules and no filters. Repair strategies are motivated only if there are static conditions --like filters-- that trigger them. Therefore, in the framework without filters, repair strategies would not have any motivation and should not be allowed. The only solution that can be proposed within this framework is to assume that the R-rules have the property of changing feature values as well as the property of filling them. However, if this were correct, we would expect that the disallowed configuration would be changed only in the way predicted by the R-rules. Thus for example, if Italian had the R-rule (3), German /u/ should always be pronounced as [i]. On the other hand, if Italian had the redundancy rule (4), /u/ should always be pronounced [u]. But this is not true. An Italian speaker can pronounce /u/ as [i], [u] or [iu], although this last pronunciation is perhaps preferred. Observe then that it is impossible to account for the pronunciation [iu] by supposing only R-rules. Therefore, in the approach in which only redundancy rules are used, one cannot account for the fact that there are different and all equally possible ways of treating the same disallowed configuration. We can thus conclude that filters are needed: only with static conditions like filters can we account for the fact that

configurations of features disallowed in a language are eliminated in a series of different ways, rather than in just one way: in fact a static condition may not have an active role in changing a disallowed configuration, but it can trigger different rules that alter it and therefore provide a variety of means by which this configuration is eliminated.

4. METAPHONY IN SOUTHERN ITALIAN DIALECTS.

One of the most interesting phenomena that characterize Italian dialects, especially in the South of Italy, is the phenomenon called metaphony. Metaphony consists of the change in quality of a stressed vowel in the context of high vowel suffixes.

In Calabrese (1986), I proposed the following analysis of metaphony in Salentino, a southern Italian dialect.

Northern Salentino has the underlying seven vowel vocalic system in (1)a) with the feature specifications in (1)b):

(1)a)	i	u						
	e	o						
	ɛ	ɔ						
		a						
(1)b)		i	e	ɛ	a	ɔ	o	u
	high	+	-	-	-	-	-	+
	low	-	-	-	+	-	-	-
	back	-	-	-	+	+	+	+
	round	-	-	-	-	+	+	+
	ATR	+	+	-	-	-	+	+

In the vowel system in (1) only the UG filters I.(1)I) and III) are

violated. Therefore, the remaining UG filters of 1.(1) are underlying filters in this vowel system

In this dialect, the metaphony rule affects stressed mid vowels in the following way. When the mid vowel target of the rule is [+ATR], it is raised to its high counterpart; when it is [-ATR], it is diphthongized. For example, we have the alternations in (2) (data from Ribezzo (1912)):

(2) in case of [+ATR] vowels:

<u>sing.</u>	<u>plur.</u>
paréte	paríti 'wall'
mése	mísi 'months'
ngrése	ngrísi 'english'
krótje	krútji 'cross'

<u>fem.</u>	<u>masc.</u>
pilósa	pilúsu 'hairy'
karósa	karúsu 'young'
frédda	friddu 'cold'

in case of [-ATR] vowels:

<u>sing.</u>	<u>plur.</u>
péte	piéti 'foot'
dénte	diénti 'tooth'
córe	cuéri 'heart'
fóрте	fuéрти 'strong'

<u>fem.</u>	<u>masc.</u>
lénta	liéntu 'slow'
bóna	buénu 'good'
mórta	muértu 'dead'

All the forms in (2) are intermediate forms. To derive the right surface forms we need to apply a rule that raises mid vowels in unstressed syllables and another rule that laxes tense mid vowels. I shall not discuss these rules here (See Calabrese (1986) for a more complete analysis of these facts). This underlying vocalic system is superficially reduced to a five-vowel system / i, u, e, ɔ, a / by a late rule that laxes tense vowels. See Calabrese (1986) for arguments in support of the existence of the underlying vocalic system in (1) in northern Salentino.

One could propose that metaphony be split into two rules: one of raising which applies to [+ATR] mid vowels, and one of diphthongization, which applies to [-ATR] mid vowels. But the point is that [-ATR] mid vowels are diphthongized exactly in the same environment in which [+ATR] mid vowels are raised, i.e., precisely when they are stressed and followed by a high vowels. Now, if we suppose that these changes are brought about by two different rules, these two rules would overlap strikingly in their structural description. If we assume that maximal simplicity and generality are required in the formulation of a phonological analysis, an overlap like this in the structural description of the two rules should be excluded. A correct

phonological analysis should therefore account for the two metaphonic changes of Salentino through the application of a single phonological rule. This is what I attempt here. I hypothesize that in Salentino there is only one metaphony rule: the effect of this rule is to raise stressed mid-vowels to high vowels when followed by a high vowel. I formulate the metaphony rule of northern Salentino as follows (I use simplified tree structures):

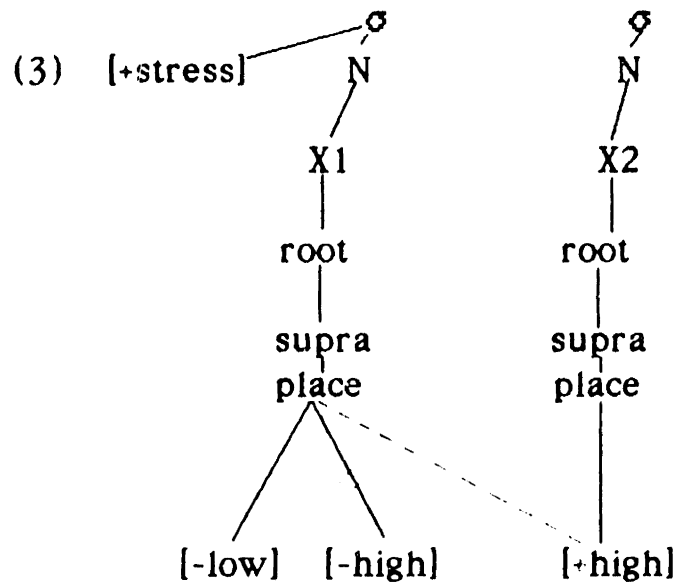

As shown, the metaphony rule spreads the feature [+high] of a high vowel X2 onto the preceding vowel X1, if X1 contains the features [-high, -low] and if X1 is stressed. In (4) and (5), I give two sample derivations:

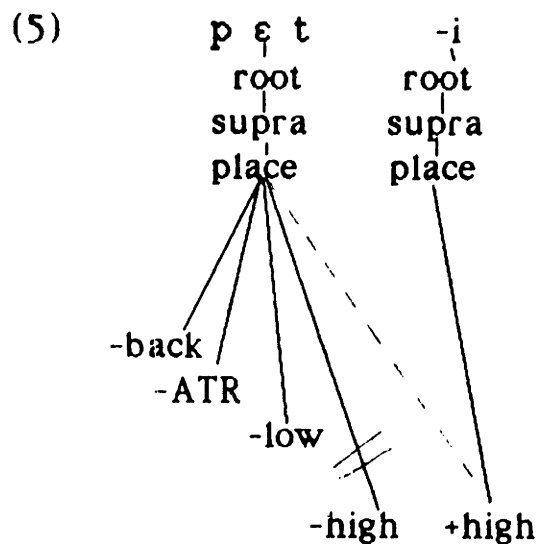
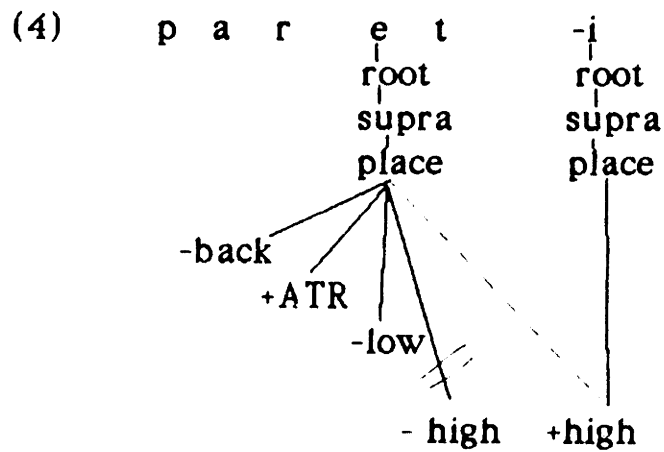

Thus, in the case of [-ATR] vowels, I assume that the metaphony rule creates a high [-ATR] vowel. The problem is why there is diphthongization in this case.[6]

Observe now that the UG filter 1.(1)V)b) -- repeated here as (6) -- is an underlying filter of northern Salentino as is shown by the fact that there are no high [-ATR] vowels:

(6) * [+high, -ATR]

The application of the rule of metaphony to [-ATR] vowels creates feature bundles containing exactly the configuration blocked by filter (6). In Section 6, I will discuss the problem of why the application of a rule like the metaphony rule is not blocked even if it creates a configuration disallowed by a filter, whereas the application of a rule like the harmony rule in Finnish and Akan would be blocked in this case. For the time being, let us assume that the application of a rule like the metaphony rule cannot be blocked. My hypothesis is then that the disallowed configuration [+high, -ATR] obtained in this way is repaired by a clean up rule, precisely, the rule of fission. Therefore, given the feature bundles in (7)a) and b) created by application of the metaphony rule to the [-ATR] mid vowels /ɛ/ and /ɔ/:

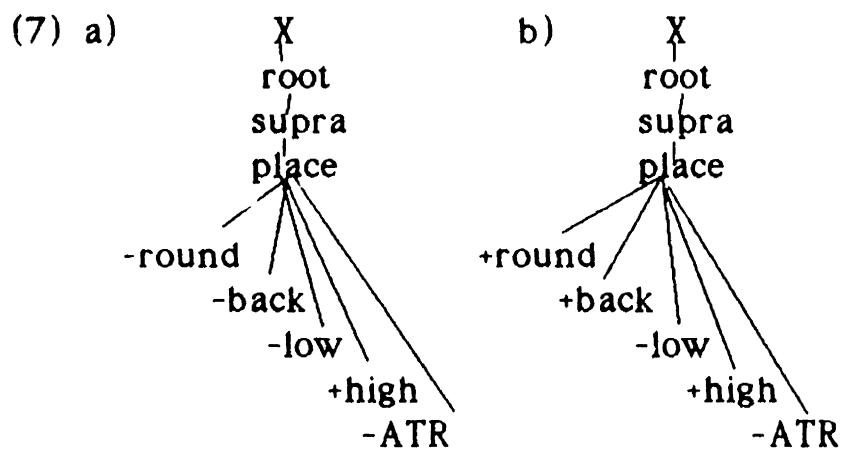

by fission, we will obtain the contour segments in (8)a) and (8)b):

(8) a)

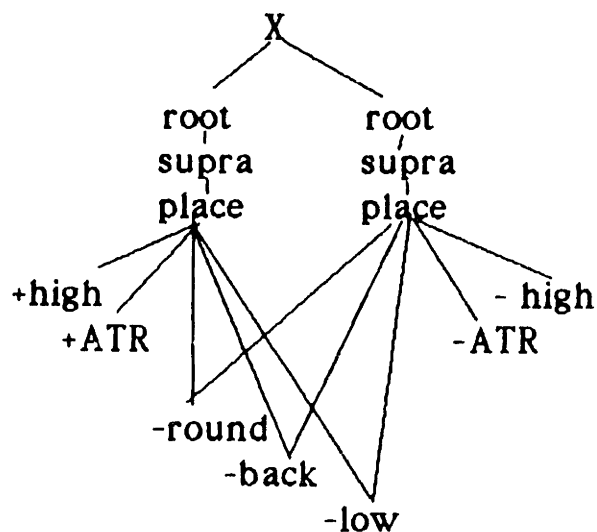

b)

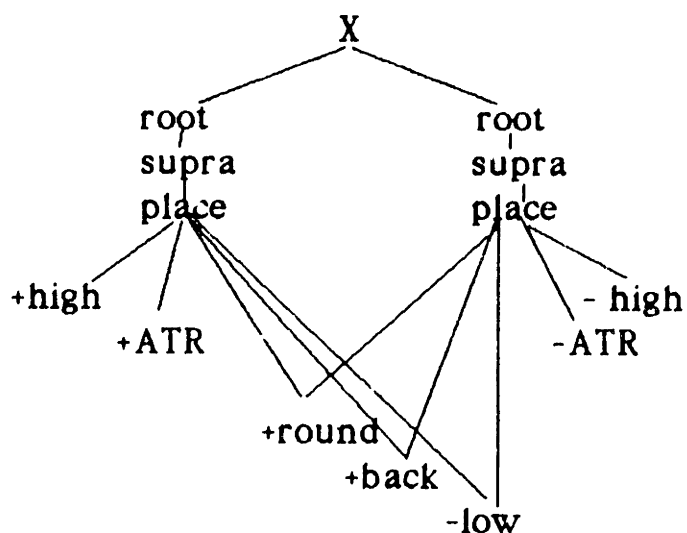

(8)a) represents the diphthong [ɛɔ], (8)b) represents the diphthong [uɔ]. For (8)b), I must hypothesize that there is a dissimilation rule in Salentino that changes [uɔ] into [uɛ]. Observe that /uɔ/ is the output of /ɔ/ in a metaphonic environment in several other southern Italian dialects similar to Salentino.[7]

We now come to a very important point. In the autosegmental representation that we see in (5), the feature value [+high] is associated

with the root node of the trigger and the root node of the target of the metaphony rule. However, the rule of fission has repaired only the disallowed configuration [+high, -ATR] which is found in the set of features dominated by the root node of the target of the rule. This is what we should expect, if we assume a principle like (9):

- (9) A clean up rule operates only inside the feature bundle that contains a configuration of features disallowed by a filter.

Therefore, when the clean up rule applies, the feature value [+high] of the trigger of the rule must be distinct from that of the target. I thus hypothesize that (9) triggers a rule which splits a feature value that belongs simultaneously to two feature bundles, when this feature value will be affected by a clean up rule in only one of these feature bundles. I propose that this rule is the following:

- (10) Given a node n_1 that is linked to two root nodes: if n_1 , together with other nodes n_2, \dots, n_3 linked to only one of these root nodes, forms the structural description of a clean up rule, then n_1 is split into two identical copies, each one linked to only one of the root nodes.

This rule can be formally represented as follows:

(11) If [F1 , ..., F2] form the structural description of a clean up rule change (i) into (ii):

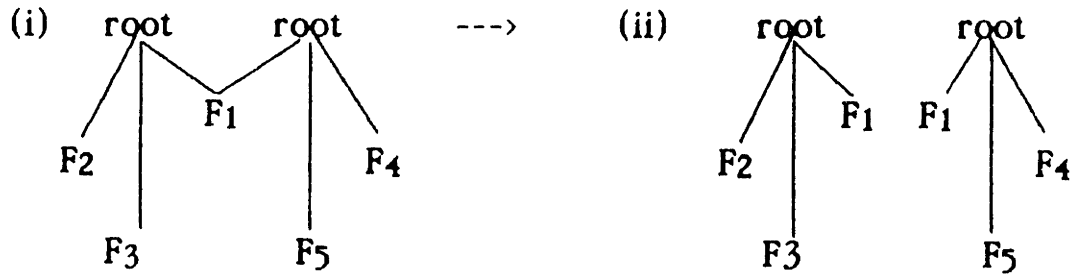

Let us consider (12), which is the configuration that we obtain through the application of the metaphony rule in (5). In (12), the disallowed configuration [+high, -ATR] created by the application of the metaphony rule to mid [-ATR] /ε/ is cleaned up by fission. Fission has the configuration [+high, -ATR] in its structural description where [+high] is associated with root node of the trigger and the target. Therefore (12) must be changed to (13) before fission can apply:

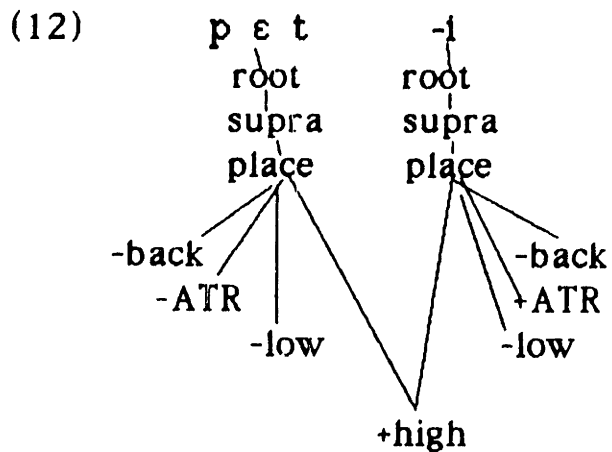

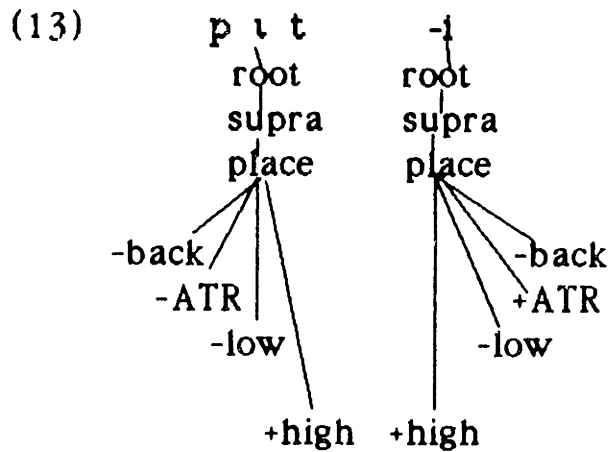

At this point the fission rule may be applied.

By hypothesizing an interaction among a phonological rule, an underlying filter and a clean up rule, I can formulate a rather simple and restrictive analysis of the Salentino facts: I can propose a very general rule of metaphony [8] and derive the different surface outputs of it by using independently motivated filters and clean up rules. The crucial hypothesis of my analysis is therefore that the phonological component contains static conditions (like the filters I am proposing) which can trigger the application of rules that repair the configurations that violate them. Without such a hypothesis, the analysis of Salentino metaphony would have to stipulate a rule that diphthongizes the [-ATR] high vowels created by the application of the metaphony rule. This would lead to a complication of the analysis, since a non-motivated phonological rule is needed to account for the facts. In my theory, this rule of diphthongization is just an instance of one of the clean up rules provided by the theory when configurations of features in violation of filters are met. This is the case of the configuration [+high, -ATR] created by application of the metaphony rule to mid [-ATR] vowels in

northern Salentino.

Observe that if I am correct in proposing that the diphthongization of northern Salentino is simply an instance of fission applied to repair the configuration [+high, -ATR] created by the application of the metaphony rule to [-ATR] mid vowels, we should expect to find also instances in which the other clean up rules are applied to repair the same configuration. And in fact, if we consider the different southern Italian dialects that have metaphonic alternations in the case of mid-vowels, we observe that although the outputs of the metaphony rule are always the same across these dialects when the targets are mid [+ATR] vowels, there is a lot of dialectal variation in the outputs when the targets are mid [-ATR] vowels. Mid [+ATR] vowels are always raised; in contrast, mid [-ATR] vowels can be diphthongized, as in northern Salentino, or tensed or raised to high [+ATR] vowels, depending on the dialect. I have shown that diphthongization is actually an instance of fission which repairs the disallowed configuration [+high, -ATR] created by the metaphony rule. I will now show that the tensing and raising of mid-vowels in a metaphonic environment are instances of application of the other clean up rules.

Let us consider southern Umbro, for example. Southern Umbro has the same vowel inventory as northern Salentino. Therefore, southern Umbro has the same set of underlying filters as northern Salentino. In southern Umbro, we have the following metaphonic alternations: [+ATR] mid-vowels are raised to their high counterparts as in Salentino, but [-ATR] mid vowels are simply tensed. For example, we

have alternations like those in (14) (data from Rohlfs (1966) and AIS):

(14) in case of [+ATR] /e/:

vérde	vírdi	'green'
néra	níru	'black'

in case of [+ATR] /o/:

tónna	túnnu	'round'
róssa	rússu	'red'

in case of [-ATR] /e/:

tʃéka	tʃéku	'blind'
péde	pédi	'foot/feet'

in case of [-ATR] /o/:

nóstra	nóstru	'our'
nóva	nóvu	'new'

Instead of postulating different rules of metaphony to explain this dialectal variation, I propose that the rule of metaphony is always the same and that the variation is due to different clean up rules. In particular, I propose that negation is the relevant clean up rule in southern Umbro.

In southern Umbro, as in northern Salentino, the application of the metaphony rule to [-ATR] mid-vowels produces the configuration [

-ATR, +high] blocked by filter (6), which holds in both dialects. My proposal is that this disallowed configuration is cleaned up by negation in southern Umbro, rather than cleaned up by fission as in northern Salentino. Thus, we have a clean up like the one in (15):

(15) [-ATR, +high] > -([-ATR, +high]) > [+ATR, -high]

That is, the high -ATR vowels produced by metaphony are changed into [+ATR] mid-vowels.

Observe that in southern Umbro, we crucially need the application of rule (10) in order to have a correct application of the clean up rule. If the feature value [+high] linked to the root node of the trigger and the target of the metaphony rule were not split into two independent copies, then negation would also affect the feature bundle of the trigger of the rule. In this way, the suffixal i would be changed into a mid-vowel. This is not correct. If, instead, rule (10) changes (16)a), the configuration obtained by application of the metaphony rule, into (16)b), then we can have a correct application of negation:

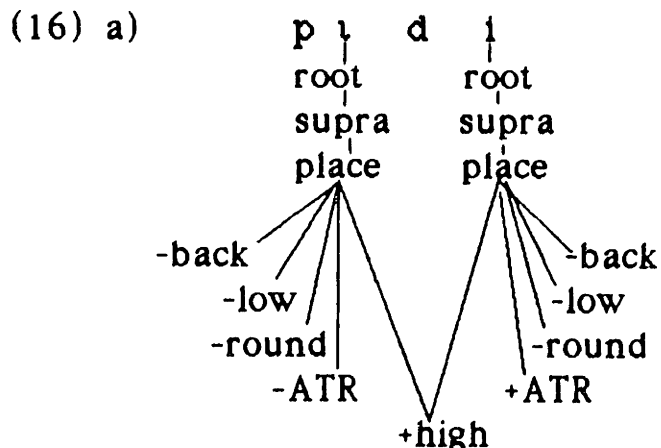

c

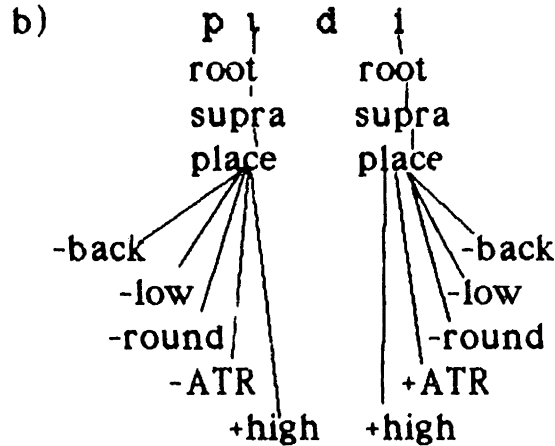

Let us consider another southern Italian dialect: the northern Pugliese dialect spoken in the town of Foggia (data from Valente (1975)). In this dialect we have the same seven-vowel system as in northern Salentino. Therefore the same underlying filters that are active in northern Salentino are active in this dialect. In northern Pugliese, we have metaphonic alternations like the following:[9]

- | | | | |
|------|--------|--------|-------------|
| (17) | mójfa | mújfu | 'soft' |
| | kyéna | kyínu | 'full' |
| | péte | píti | 'foot/feet' |
| | gróssa | grússu | 'big' |

I propose that the metaphony rule of the Pugliese of Foggia is identical to that of northern Salentino and southern Umbro. Therefore, we obtain high [+ATR] vowels from mid [+ATR] vowels, and we obtain high [-ATR] vowels from mid [-ATR] vowels. My hypothesis is then that the disallowed configuration [-ATR, +high] is cleaned up in this dialect

by delinking the feature [-ATR], which is replaced with the feature [+ATR] as we see in (18):

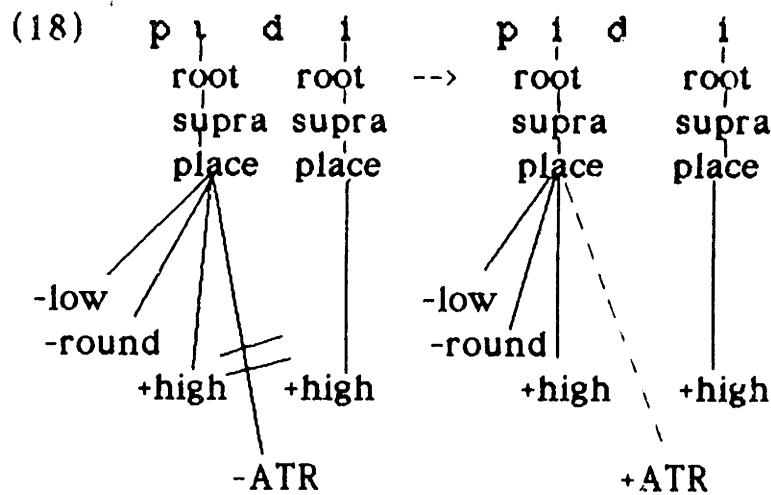

In (18), the high [-ATR] vowel which is produced by metaphony is changed into a high [+ATR] vowel.

There is a northern Italian dialect, the Veneto spoken in Vicenza, Padova and Rovigo, in which only [+ATR] mid vowels are raised in a metaphonic context; lax vowels are instead not affected by the rule. Veneto, which has the vowel system in (19), has metaphonic alternations like those in (20)a) in the case of [+ATR] vowels (from Renzi (1985), Rohlf's (1966):

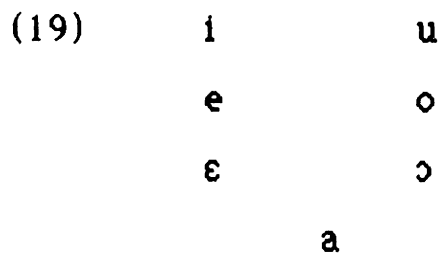

(20) a)	vedo	te vidi	'I see/ you see
	coro	te curi	'I run/you run
	toso	tusi	'boy/boys

There is, however, no metaphonic alternation in the case of [-ATR] vowels:

(20) b)	prete	preti	'priest sing./pl.'
	mɔdo	mɔdi	'way sing./pl.'

One might be tempted to account for this different behavior of mid-vowels by assuming that the metaphony rule of Veneto, like that of northern Salentino, southern Umbro and northern Pugliese, applies to all mid-vowels, and that the configuration [+high, -ATR] created when the rule applies to mid [-ATR] vowels is cleaned up by delinking of [-ATR]. However, I assume that if a disallowed configuration created by application of a phonological rule to a feature bundle is repaired by delinking the feature assigned by this rule, then there is an automatic reanalysis of the derivation in which there is no application of the phonological rule to this feature bundle. This reanalysis is probably an instance of the Derivational Simplicity Criterion (DSC) proposed by Kiparsky (1982). The DSC states the following:

- (21) Among alternative maximally simple grammars select that which has the shortest derivations.

In a situation in which the same form can be derived through application of a phonological rule and successive application of a clean up rule, or simply through non-application of this phonological rule, the DSC imposes the selection of the latter alternative. In this way, I exclude the possibility that the application of a clean up rule makes the application of a phonological rule vacuous.

An interesting consequence follows from this analysis of metaphony. We have seen that the results of metaphony can vary from dialect to dialect. Instead of proposing a different rule of metaphony for each different dialect to account for this dialectal variation, I have proposed that the metaphony rule is always the same, and that the dialectal variation is a result of the fact that a different clean up rule is chosen to repair the disallowed configuration produced by the metaphony rule in the case of the [-ATR] mid-vowels. I hypothesize that in the historical development of each particular dialect, one of the possible clean up strategies has been grammaticalized as the solution to the disallowed configuration produced by the metaphony rule. In this way, I account for the observed dialectal variation in the phenomenon of metaphony. Therefore, the range of variation that we find should be limited to the range of results produced by the clean up rules. And in fact this is what we find. Therefore by using a theory that contains static conditions, like filters, and a set of clean up rules that repair violations of these conditions, we are able to achieve a meaningful simplification of the treatment of dialectal variation found in the case of a phonological rule like metaphony. A theory which does not contain such conditions and rules would instead assume that each dialect has

different metaphony rules, and therefore would not account for the common properties that these rules have.

Now I need to discuss an important difference between the application of the clean up rules in the case of the Italian pronunciation of German /ü/, and the application of the clean up rules in the case of metaphony. In the first case, any one of the available clean up strategies for the disallowed configuration [+round, -back] [10] can be applied in the same dialect of Italian. For example, I can pronounce German /ü/ sometimes as [i], sometimes as [u], and sometimes as [iu], although I prefer the last pronunciation. This is not what happens in the application of the clean up strategies in the case of the disallowed configuration produced by metaphony. In this case, for each dialect, only one of the possible clean up strategies is used. I know of no cases where in a given dialect, the output of metaphony applied to [-ATR] mid vowels can be variable, i.e., sometimes a diphthong, sometimes a [+ATR] mid vowel, sometimes a high [+ATR] vowel.

I propose that the difference between these two cases lies in the fact that they belong to two different linguistic levels. The case of the different pronunciations of a foreign sound properly belongs to phonetic performance. The case of the different treatments of the outputs of metaphony applied to [-ATR] mid-vowels properly belongs to phonology. This hypothesis has two implications. First I assume that filters are active also in phonetic performance; in this case they trigger variable application of the clean up rules. Secondly, I assume that the

choice among one of the clean up strategies is a grammaticalized aspect of the phonology of a language. Therefore, I assume that for each configuration of features in violation of a filter which may be produced in the course of the phonological derivation, the grammar must state which clean up strategy is selected to repair it. This is similar to the choice of a parameter within a given language, but differs in that here we select a solution from a set of several alternatives instead of selecting a value of a binary alternative.

Now the problem is to account for why we do not have variable application of the clean up rules in the phonological component, so that they must be grammaticalized. I propose that this is a consequence of the following principle that imposes the selection of a clean up rule in the phonological component:

(22) Variable application of rules is disallowed in the phonological component.

Thus, I hypothesize, quite obviously, that grammaticalization is the historical process which transforms low phonetic variable processes into phonological ones. In this way, for example, one of the possible variable Italian pronunciations of the German word fuhrer can become a lexical borrowing of Italian. And I hypothesize that this is the way in which different clean up rules historically were chosen as repair strategies of the disallowed outputs of the metaphony rule in the southern Italian dialects discussed above.

5. DISALLOWED CONFIGURATIONS OF FEATURES AND THE SPECIFICATIONS OF FEATURE VALUES

It is obvious that if the application of a rule produces a configuration of features in violation of a filter, then the features of this configuration which are not introduced by the rule must be already specified before the rule applies. Only in this way can we obtain a configuration of conflicting features. Let us consider a concrete example to clarify this point. There is a series of southern Italian dialects which have a five vowel system rather than a seven vowel one. This is the case of central Salentino, for example, where we have the vowel system in (1):

(1) i u
 ε ɔ
 a

In this dialect, as in the dialects discussed previously, we have metaphonic alternations in the case of mid vowels: in particular, they are diphthongized, when they are stressed and followed by a high vowel. In (2) I give examples from the dialect of Campi Salentina, my hometown:

(2) pete pletɪ 'foot/feet'
 sta ttene stə ttieni 'he has/you have'
 lenta lɛntu 'slow fem./masc.'

bona buenu 'good fem./masc.'
sta mmore sta mmueri 'he is dying /you are dying'

If the analysis of metaphony proposed in the preceding section is correct, the diphthongization that we have in (2) is actually a case of fission applied to repair the disallowed configuration [+high, -ATR] created by the metaphony rule.

Now in the vowel system in (1) the UG filter 1.(1)III) --repeated here as (3) --, as well as 3.(6), belong to the set of underlying filters:

(3) *[-high, +ATR]

If, as I discussed in Section 3, an R-rule corresponds to each underlying filter, we must suppose that the following R-rules hold in central Salentino:

(4) a) [-high] --> [-ATR]
 b) [+high] --> [+ATR]

It is now obvious that in this dialect, the feature value [-ATR] must already be specified by (4)a) in the feature bundle of the mid vowels, when the metaphony rule applies. If it were not specified, the metaphony rule would create a feature bundle that contained the feature value [+high], but no feature value for [ATR]. Therefore, we

should expect an application of the R-rule in (4)b). And therefore, we would get a feature bundle that contains the configuration [+high, +ATR]. In this way, the mid-vowels would be changed into high vowels. This is not what happens in central Salentino. If the diphthong that we find in this dialect is the result of fission used to to repair the disallowed configuration [+high, -ATR] created by the application of the metaphony rule, we must then suppose that the feature value [-ATR] is already specified when the metaphony rule applies.

Given what I will propose in the Section 6, I now want to hypothesize that if the application of a rule produces a configuration of features in violation of an underlying filter, all the features of this configuration must already be specified before the rule applies, not just the features not introduced by the rule. Therefore, I hypothesize that the feature value affected by the rule must also be specified when the rule applies. In this sense, rules whose application can produce configurations of features that vioiate filters must always be feature-changing rules.

5. BRIEF EXCURSUS.

I would like to exclude the possibility that the clean up rule that applies to repair the configuration [+high, -ATR] in a language like central Salentino could be delinking of [-ATR]. If this were possible, we would obtain the same configuration that we would get if the metaphony rule had applied before the application of the R-rules. I

want to exclude situations in which we can obtain the same surface form through two different derivations. Now if we assume the Derivational Simplicity Criterion in 3.(21), this is exactly what we get. In fact, according to the DSC, if there is a possibility of deriving a certain configuration either by successive applications of a phonological rule and the R-rules or by successive application of the R-rules, a phonological rule and then a clean up rule, the shortest derivation is automatically chosen. Therefore, I assume that if delinking of [-ATR] were chosen to repair the configuration [+high, -ATR] in a language like central Salentino, the DSC would have forced an immediate reanalysis in which the metaphony rule applies before the R-rules apply. I dare to hypothesize that this is the way in which transparent neutral vowels usually appear in the phonology of a language.

6.THE APPLICATION OF PHONOLOGICAL RULES AND FILTERS.

We now come to a crucial problem that must be solved. In Section 3, we saw that the application of phonological rules is blocked if it produces configurations disallowed by underlying filters; this was the case of the vowel harmony rule of Finnish and Akan. In Section 5, I have instead proposed that the application of phonological rules can produce configurations disallowed by underlying filters, but that clean up rules then apply to repair these configurations. I assume that the metaphony rule in southern Italian dialects applies in this way. In my analysis of metaphony, the metaphony rule is allowed to apply to the mid [-ATR] vowels and thereby creates a configuration in violation of the underlying filter 3.(6). After this configuration is produced, the

presence of this filter triggers the application of the clean up rules to repair it. Therefore, I am proposing that there are two possible cases. The first is one in which the application of a rule which produces a violation of an underlying filter is blocked by the presence of that filter. The second is one in which this application is allowed, but the presence of the filter violated by the application of the rule then triggers the application of the clean up rules. I hypothesize that the difference between these two cases is related to the way in which the feature bundle to which the rule applies is specified.

Observe that there is an important difference between a vowel harmony rule like that of Finnish and the metaphony rule. The vowel harmony rule of Finnish affects the value [-back], which is redundant and underlyingly absent in the feature bundle of the neutral vowels /i/ and /e/. Only in this way can we account for the fact that these vowels are transparent to the harmony rule. Therefore, if the harmony rule could have applied to the feature bundle of the neutral vowels, it would have behaved as a feature filling rule. This could not occur with the metaphony rule. The feature value [-high] affected by the rule is a distinctive value, not a redundant one, in the feature bundle of the mid-vowels which are targets of the rule. As I proposed in Section 5.1, this feature value is specified when the metaphony rule applies. Therefore, this rule must be considered to be a feature-changing rule.

Now I want to propose that a crucial difference exists between the ways in which rules are applied: a rule whose application to a feature bundle would produce a violation of an underlying filter is

prevented from applying to this feature bundle if it affects a feature value that is redundant and unspecified in this feature bundle. It is instead free to apply to this feature bundle if it affects a feature value that is specified in it.

I therefore propose that the different modes of application of a phonological rule are due to the following principle:

- (1) Given a feature F in a feature bundle B, one cannot fill in the unspecified value of F with a value a disallowed by an underlying filter in B.

In order to make (1) clearer, I need to consider the relationship between underlying filters and redundant values. Observe that in a phonological system that has the underlying filter *[bF₁, aF₂], if bF₁ is underlyingly specified, then we have to suppose the R-rule (2):

- (2) [bF₁] --> [-aF₂]

Therefore, if a feature bundle in this phonological system contains [bF₁], then it also contains [-aF₂] as a redundant value. Given this, we can say that principle (1) prevents a rule from applying to a feature bundle B if it assigns to B a feature value that is the opposite of a feature value redundant and unspecified in B. However, principle (1) predicts that this rule is free to apply if this redundant feature value is already specified when the rule applies or if the rule assigns a value to a

feature that is distinctive in this feature bundle. This last case is possible because, by definition, a feature is distinctive in a certain feature bundle if neither of its values is disallowed by an underlying filter in that feature bundle.

Therefore, the application of a phonological rule P to a feature bundle B is governed in the following way: a) If P assigns a value to B that is the opposite of a redundant feature value in B and if P applies before the R-rules are applied, then principle (1) prevents P from applying. b) If P affects a distinctive value or a specified redundant value in B, it is not constrained by principle (1) and therefore can be freely applied. Configurations of features that violate underlying filters can be created in this way. And clean up rules that repair them must be applied.

Finnish vowel harmony is a clear case in which principle (1) prevents a rule from applying to a feature bundle. According to what I am proposing, the harmony rule of Finnish cannot apply to the feature bundle of neutral vowels /i/ and /e/ because its redundant value [-back] is not specified when the rule applies, and because the rule assigns the feature value [+back]. As I observed before, it is easy to show that the redundant feature value [-back] is absent when the rule applies. In fact, in this way, it is possible to explain the fact that neutral segments /i/ and /e/ are transparent to the harmony rule: the harmonic value can be spread across them since they do not have a value on the tier on which the spreading occurs. In Chapter 2, Section 2, we will see several cases that support this proposal. The case of the

vowel harmony rule of Akan is more problematic. There is no clear argument that demonstrates that the redundant value [-ATR] of the opaque neutral /a/ of Akan is underlyingly unspecified. I will not discuss the case of opaque neutral vowels here. If we consider only transparent neutral vowels, however, there is supporting evidence for the hypothesis that the application of a phonological rule to a feature bundle is blocked by the presence of a filter, if this rule applies at a stage in which the redundant values are not yet specified.

Let us consider now the cases in which phonological rules create configurations in violation of filters. According to (1), these rules should affect distinctive values or redundant values that have already been specified. We have two cases: 1) the phonological rule can modify a distinctive feature value; 2) the phonological rule can modify a specified redundant feature value. Let us consider the first case. This is the case of the metaphony rule which affects the distinctive feature value [-high] of the mid vowels. It may be applied even if it creates a configuration disallowed by a filter. Therefore the prediction made by (1) is correct. Rules of this kind can freely violate filters.

Let us consider now the case of a rule which affects a redundant value. This is a crucial case in support of my approach. Principle (1) makes the following prediction: if a rule can affect a feature value that is redundant in a given feature bundle and can thereby create a disallowed configuration, then this feature value must already be specified when the rule applies.^[11] I will now consider two languages.

which display a rule that affects redundant values and produces configurations in violation of a filter. In both cases it can be shown that the the redundant values are already specified when the rule applies as expected from principle (1). These languages are Ogori, a Kwa language of Nigeria, (Section 7) and Chukchi, a Paleo-Siberian language (Section 8).

7. VOWEL HARMONY IN OGORI.

The first language that I will consider is Ogori, an eastern Kwa language spoken in Nigeria. My data are drawn from a very interesting article by S. Chumbow (1982).

The Ogori vowel system has seven oral vowels paralleled by seven nasalized vowels, as we can see in (1):

(1)	i	í	u	ú
	e	ẽ	o	õ
	ɛ	ẽ	ɔ	õ
		a	ã	

According to Chumbow, the nasalized vowels behave like their oral counterparts with respect to vowel harmony. Therefore, in the discussion of vowel harmony that follows, they will not be given a separate treatment.

The vowels of Ogori are specified in the following way:

(2)

	i	ɪ	e	ẽ	ɛ	ě	a	ǎ	ɔ	ɔ̃	o	õ	u	ũ
high	+	+	-	-	-	-	-	-	-	-	-	-	+	+
low	-	-	-	-	-	-	+	+	-	-	-	-	-	-
back	-	-	-	-	-	-	+	+	+	+	+	+	+	+
round	-	-	-	-	-	-	-	-	+	+	+	+	+	+
ATR	+	+	+	+	-	-	-	-	-	-	+	+	+	+
nasal	-	+	-	+	-	+	-	+	-	+	-	+	-	+

In the vowel system of Ogori, the UG filters 1.(1)I), III), VII) are underlyingly violated. Therefore the remaining UG filters in 1.(1) are the underlying filters of Ogori. The fact that the UG filters 1.(1)V)b) and VI)b) are underlying filters of Ogori is particularly important for my analysis is . I repeat them as (3) and (4):

(3) *{+low, +ATR}

(4) *{+high, -ATR}

Given (3) and (4), I suppose the following R-rules:

(5) [+low] --> [-ATR]

(6) [+high] --> [+ATR]

(5) states that the feature value [-ATR] is redundant in a feature

bundle that contains [+low] and (6) states that the feature value [+ATR] is redundant in a feature bundle that contains [+high].

Let us consider vowel harmony in Ogori. An interesting property of vowel harmony in this language is that root harmony must be clearly distinguished from affix harmony: the two kinds of harmony phenomena are apparently very different. Let us begin with root harmony. The mid vowels /e/ and /o/ never cooccur with /ɛ/ and /ɔ/ in roots while, on the other hand, /i/, /u/ and /a/ may cooccur with any of the four mid-vowels and with each other. This is illustrated in the following roots: (12)

- | | | |
|-----|---------|------------|
| (9) | òbòrò | 'good' |
| | róró | 'think' |
| | džé | 'eat' |
| | ìgbegbě | 'knife' |
| | ógbě | 'child' |
| | fó | 'die' |
| (8) | śáś | 'axe' |
| | śɔre | 'fry' |
| | śè | 'hold' |
| | wśré | 'deceive' |
| | śrś | 'laughter' |
| | śtélé | 'pot' |

(9)	ójí	'röpe'	ǰgà	'shout'
	úbó	'house'	físe	'disappear(caus.)'
	íwú	'body'	kpáré	'pluck'
	úwóbigbe	'force'	béfuwà	'spoil'
	èbà	'type of food'	múwé	'laugh'
	tíjégúró	'sing'	bílá	'return'
	gúbà	'help'	fúrá	'leave'
	síjéré	'play'	rúwá	'divide'

If one considers only what happens in roots, it is possible to say that we have a normal case of +/- [ATR] harmony with /i/, /u/ and /a/ as neutral vowels. However, this is not true if we consider affix harmony. In Ogori, root vowels determine the harmonic category of the affixes. There is no affix that can control the harmonic category of the root or of another affix. In this language, we have prefixes and suffixes whose harmonic category is determined by the closest vowel in the root. No neutral vowels are found in the affixes. Affixes that are in a [+ATR] environment display the vowels [i], [u], [e] and [o]; the same affixes in a [-ATR] environment display the vowels [ɛ], [ɔ], [a] and [ɔ] respectively. Therefore, we have the following alternations ((24) of (Chumbow (1982))):

(10)	A	B	Examples of alternating affixes	
	+ATR	-ATR		
(i)	i	ɛ	<i>i - è</i> <i>bí - be</i> <i>bì - bè</i> <i>tì - tè</i> <i>nì - nè</i> <i>dèkì - dàkè</i>	1st pers. singular(I) infinitive marker 3rd pers. plur. 1st pers. plur. 2nd pers. plur. habitual aspect
(ii)	e	a	<i>é - á</i> <i>è - à</i> <i>e - a</i> <i>be - ba</i> <i>eke - aka</i> <i>me - ma</i> <i>dèkì - dàkè</i>	incompletive aspect 3rd p. s. sub. pron.. 3rd p. s. obj. pron. 3rd p. p. obj. pron. future aspect negation habitual aspect
(iii)	u	o	<i>ù - ò</i> <i>ù - o</i> <i>tù - tò</i> <i>nù - nò</i> <i>mù - mò</i>	2nd p. s. subj. pron. 2nd p. s. obj.pron. 1st p. p. obj.pron. 2nd p. p. obj. pron. 1st p. s. obj .pron.
(iv)	o	o	<i>o - o</i>	nominalization

I give a series of examples that illustrate affix harmony. I consider first the infinitive marker that exhibits the two alternating prefixes **bí** - **bé**:

(11) Verb	Infinitive	Verb	Infinitive
sú 'have'	bísú	jó 'go'	béjọ
dí 'know'	bídí	džó 'sell'	bédžó
múné 'run'	bímúné	šá 'come'	béšá
síjé 'do'	bísíjé	wóré 'cheat'	béwóré
jí 'buy'	bíjí	sé 'hold'	bésé

The 3rd person singular subject pronoun exhibits the two alternating suffixes **è** - **a** :

(12)	è-jé	'he calls'
	à-né	'he flings'
	è-roró	'he thinks'
	à-kpọ	'he climbs'

In (13) I consider some cases of object pronouns. They are suffixal morphemes and can also be attached to a preposition:

(13) mú/mó 'me'	tùrùtò-mú 'near me'	nè-mò 'for me'
ú/ó 'you(s.)	tùrùtò-ú 'near you(s.)	nè-ò 'for you(s.)'
é/á 'him'	tùrùtò-é 'near him'	nè-à 'for him'
tú/tó 'us'	tùrùtò-tú 'near us'	nè-tò 'for us'
nú/nó 'you(p.)	tùrùtò-nú 'near you'	nè-nò 'for you(p.)'
bé/bá 'them'	tùrùtò-bé 'near them'	nè-bà 'for them'

Let us consider the behavior of affixes with roots that contains the vowels /i/, /u/ and /a/: affixes display their [+ATR] alternant when the closest root vowel is /i/ or /u/ and their [-ATR] alternant when the closest vowel is /a/. This is illustrated in (14):

(14) a) è é fúrá	b) * à á fúrá
he - is - standing	
c) bì rùwá tó	d) * bè rùwá tó / * bì rùwá tú
they - divide - us	
a) ní síjára	e) * nɛ síjára
You (plur.) - play	

If we consider affix harmony, we can say that vowel harmony in Ogori is a case of root dominant bidirectional vowel harmony. There are two problems that an analysis of this vowel harmony system must account for. One problem concerns why the vowels /i/, /u/ and /a/ appear to

be neutral in roots, but have harmonic alternants in the affixes. The other concerns the fact that the harmonic alternations between vowels i - ε, u - ɔ, and e - a are not the ones that should be phonetically expected in this harmony system based on +/- [ATR] alternations.

In order to answer these questions, we have to analyse the different properties of root and affix harmony. As we shall see below, there is clear evidence to say that affix harmony must be accounted for by hypothesizing a feature-changing rule that can apply to all vowels, including /i/, /u/ and /a/. If this is correct, we then have to assume that this rule does not apply in roots. I therefore hypothesize that the proper way to account for the difference between root and affix harmony is to assume that the rule that accounts for affix harmony is a cyclic rule, so that it is prevented from applying morpheme-internally, and therefore root-internally by the strict cycle. The harmonic properties of the roots should then be treated by a morpheme structure condition that constrains the cooccurrence of [ATR] values in roots. Observe that this morpheme structure condition must be sensitive only to [ATR] values of mid-vowels. In fact it must state that they are always identical within the same root. However, the condition must not be sensitive to the [ATR] values of high and low vowels that can occur freely with any other value for [ATR] within the same root. The obvious difference between the [ATR] values of the mid-vowels and those of the high and low vowels in the phonological system of Ogori is that whereas the former values are distinctive, the latter are redundant. Therefore, the morpheme structure condition that constrains vowel cooccurrence

in Ogori roots seems to be sensitive to distinctive values, but not to redundant values. This fact can be accounted for by the following hypotheses: first, that distinctive feature values are underlyingly specified in Ogori, whereas redundant feature values are underlyingly unspecified; and secondly that the morpheme structure condition which is formulated in (15) holds only for underlying representations:

$$(15) \text{ if: } \begin{array}{c} \text{N} \\ | \\ \dots \text{X} \dots \text{X} \dots \\ | \quad | \\ \alpha\text{ATR} \quad \alpha\text{ATR} \end{array}$$

Observe that if this analysis is correct, I need to assume that /i/ and /u/ are underlyingly specified as [+high], and that /a/ is underlyingly specified as [+low]. In fact, only in this way can the R-rules (5) and (6) characterize [+ATR] as redundant in the feature bundles of /i/ and /u/ and [-ATR] as redundant in the feature bundle of /a/.

I therefore account for the neutrality of /i/, /u/ and /a/ in roots by hypothesizing that their value for [ATR] is underlyingly unspecified, and that there is a morpheme structure condition which blocks the cooccurrence of disharmonic [ATR] values in underlying representations. [13]

Now the harmonic alternations in the affixes remain to be explained. The first thing to determine is what vowels are underlying in the affixes that display harmonic alternation between $\underset{-}{i}$ and $\underset{-}{e}$, $\underset{-}{u}$ and

ɔ̄ . a and e. Let us first consider the affixes that display the alternations between i and ɛ and u and ɔ̄. If ɛ and ɔ̄ were the underlying vowels in these affixes, we should expect that they would be changed into e and o when they are in a [+ATR] environment. There is no reason in the Ogori phonological system to prevent the appearance of the vowels e and o in this case. They are possible phonemes of Ogori and appear both in roots and affixes. To explain the fact that ɛ and ɔ̄ are raised to i and u, we should hypothesize an ad hoc rule like (16), which applies after the harmony rule has assigned [+ATR] to ɛ and ɔ̄ in the affixes:

$$(16) \begin{bmatrix} -\text{high} \\ +\text{ATR} \end{bmatrix} \rightarrow [+high]$$

But then why doesn't this rule affect /e/ and /o/ in the roots or, more particularly, the e and o that we find in affixes as [+ATR] variants of /a/ and /ɔ̄/. Observe that underspecification would not help in accounting for the change from mid-vowels to high vowels in a [+ATR] context, since we would have to rely upon a R-rule like the following:

$$(17) [+ATR] \rightarrow [+high]$$

(17) is absolutely not justified on theoretical grounds, as we will see in Chapter 2. Furthermore, it is not justified in the Ogori vowel system, where there are [+ATR] mid-vowels. Observe also that if /ɔ̄/ were the

underlying vowel in the alternation $\underset{\sim}{\text{ɔ}} - \underset{\sim}{\text{u}}$, we would then have two /ɔ/'s which have different variants in a [+ATR] environment: one becomes [u] and the other becomes [o]. This cannot be correct.

Therefore, if we hypothesize that /ɛ/ and /ɔ/ are the underlying vowels in the alternations $\underset{\sim}{\text{i}} - \underset{\sim}{\text{ɛ}}$, $\underset{\sim}{\text{u}} - \underset{\sim}{\text{ɔ}}$ in the Ogori affixes, then we cannot explain these alternations. If the underlying vowels of these affixes cannot be the mid-vowels /ɛ/ and /ɔ/, they must then be the high vowels /i/ and /u/. Now, given the theory that I proposed in the preceding sections, if the high vowels /i/ and /u/ are the underlying vowels in these alternations, we have a straightforward explanation of why [ɛ] and [ɔ] are the variants of /i/ and /u/ in a [-ATR] environment. Observe that /i/ and /u/ must be underlyingly specified as [+high]. As we have seen before, it is only in this way that we can explain why they appear to be neutral in roots. Now when they are in a [-ATR] context, they will be assigned the feature value [-ATR]. Therefore, we will obtain feature bundles with the configuration of feature values [+high, -ATR], which is disallowed by the underlying filter in (6). Therefore, a clean up strategy must apply to repair this configuration. I hypothesize that the clean up strategy chosen in this case is delinking of [+high]. In this way, the configuration [+high,-ATR] is changed into the configuration [-high, -ATR]. Thus /i/ and /u/ are changed into [ɛ] and [ɔ] in a [-ATR] environment. We can conclude then that there is clear motivation to suppose that the underlying vowels of the harmonic alternations $\underset{\sim}{\text{i}} - \underset{\sim}{\text{ɛ}}$, $\underset{\sim}{\text{u}} - \underset{\sim}{\text{ɔ}}$ are the high vowels, and that the explanation for

these alternations must rely upon the idea that there are configurations of features that are blocked by filters and repaired by clean up rules.

There are also arguments to show that the underlying vowel in the affixes that display the alternation a - e is the low vowel. In fact, if it were the mid-vowel /e/, we would not be able to explain the alternation. If it were /e/, why do we not find the [-ATR] mid-vowel [ɛ] in a [-ATR] environment --/ɛ/ is a possible phoneme of Ogori. We could therefore suppose a rule that lowers [ɛ] to [a]. But this is impossible since this rule would also lower the [ɛ] which is the [-ATR] variant of /i/ as well as the /ɛ/ in the roots. Underspecification would not provide any better solution in this case either, since we should hypothesize that the following R-rule hold in Ogori:

(18) [-ATR] --> [+low]

This R-rule rule, like (17), is not possible for theoretical reasons, as we will see in Chapter 2. Moreover, it cannot be justified in the vowel system of Ogori since there are mid [-ATR] vowels. If /e/ cannot be the underlying vowel of the alternation e - a, then of course it must be /a/. But if it is /a/ then, as with /i/ and /u/, we have a straightforward explanation of why /a/ is changed to [ɛ] in a [+ATR] environment. Observe that /a/ must be underlyingly specified as [+low] as we have seen previously in the discussion of root harmony: if /a/ is underlyingly [+low], it is then possible to explain why it appears to be neutral in that case. Now when /a/ is in a [+ATR] environment, it will

be assigned the feature value [+ATR]. Therefore, the configuration [+low, +ATR], which is disallowed by the underlying filter in (5) is produced. Thus a clean up rule must be applied to repair this disallowed configuration. I hypothesize that delinking of [+low] is chosen as the clean up strategy. Therefore, we will obtain the configuration [-low, +ATR].^[14] Hence, /a/ is changed into [e] in a [+ATR] environment. There is then clear motivation to hypothesizing that /a/ is the underlying vowel in the alternation a - e and that [e] is derived from /a/ through application of a clean up rule which repairs the disallowed configuration created by the harmony rule.

Therefore, I can conclude that if we suppose 1) that /i/, /u/ and /a/ are underlying vowels in the affixes that display alternations like i - e, u - ə and e - a; 2) that the harmony rule spreads both values of [ATR] and 3) that we have application of clean-up rules to repair the disallowed configurations [+low, +ATR], [+high, -ATR] created by the harmony rule, then we can account for the unexpected harmonic alternations found in the affixes straightforwardly.

If this analysis is correct, then by principle 6.(1) we are forced to assume that the harmony rule of Ogori applies when the redundant values for [ATR] are already filled in in the feature bundles of the high and low vowels. In fact, I can demonstrate that this is true. The argument is very simple. Let us suppose that the harmony rule applies before the R-rules apply. Then, when the harmony rule applies, the redundant value [-ATR] should be unspecified in the feature bundle of

/a/ in a root like šá. Therefore, we should expect that a prefix like pí should not be assigned a harmonic value when it is combined with such a root. We should thus expect that the unspecified feature [ATR] in the feature bundle of /i/ in this prefix be filled in by (6) since it was not assigned a harmonic value. The prefix should thus surface with its variant pí when combined with the root šá and we should obtain the sequence pí šá. But this is not what we get. In fact, what we actually obtain is béšá. This is what we expect if /a/ in the root has its redundant value [-ATR] already specified when the harmony rule applies. This redundant value is assigned by the harmony rule to the high vowel of the prefix. Therefore, the disallowed configuration [+high, -ATR] is created, and delinking of [+high] is applied to repair it. In this way, we obtain [-high, -ATR] ɛ of béšá.

In the same way, if the /u/ of a root like sú were unspecified for [ATR] when the harmony rule applied, we should expect that a prefix like à should not get a harmonic value. Therefore we should expect that the feature bundle of the /a/ of this prefix is filled in by (5) so that we obtain the sequence *à sú. But this is not what we get. What we actually obtain is è sú, which is what we expect if the redundant value [+ATR] is already specified in the feature bundle of /u/ of the root when the harmony rule applies. This means that by the time the harmony rule applies, the R-rules have already been applied. If the R-rules have applied in the roots, they must also have applied in the affixes. Therefore, the feature bundle of /i/, /u/ and /a/ in the affixes

must contain the redundant values [+ATR], [-ATR] when the harmony rule applies. This is what principle (1) predicts: the application of the harmony rule to affixes in Ogori may affect redundant values and create configurations of features that violate underlying filters. Therefore, it must apply only when the redundant values have already been specified.

If my argument and analysis are correct, the harmony rule that applies in affix harmony in Ogori must be a feature-changing bidirectional rule. Therefore, it should be formulated as in (19):



An interesting problem now arises. If the rule is that in (19), how can I account for the fact that only vowels in the roots can trigger it -- never vowels in the affixes. I have shown that both vowels in the roots and vowels in the affixes already have their values for [ATR] specified when the harmony rule applies. Therefore, if (19) is the harmony rule, it should be triggered by the feature value for [ATR] present in vowels of both roots and affixes. This is not only incorrect, but impossible, since we would not be able to decide what value of [ATR] would be a trigger or a target of the rule.

Observe that (19) must also be prevented from applying root-internally, since /i/, /u/ and /a/ are not affected by (19) root-

internally. I could assume that rule (19) applies cyclically. The strict cycle would then prevent (19) from applying root-internally; it would not, however, prevent a vowel in an affix from being the trigger of the rule. Therefore, we would still need to explaining why (19) is triggered only by vowels in the root and not by vowels in the affixes.

Thus I am forced to hypothesize that (19) must be constrained in such a way that only a vowel belonging to the root can be a trigger of the rule. I propose therefore that (19) must be reformulated as (20):

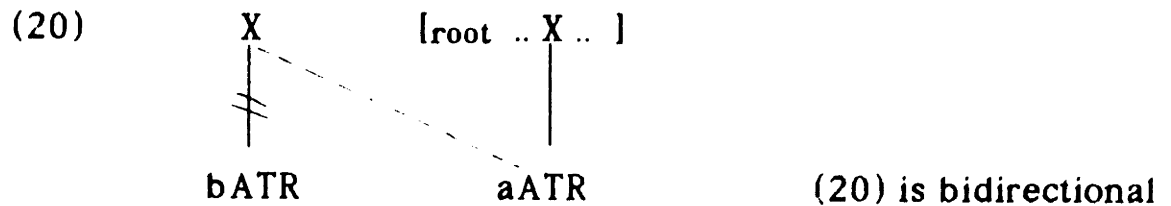

(20) must be a cyclic rule, since its application is blocked root internally.

I will now discuss some sample derivations. Let us consider the two sentences in (21):

- (21) a) à á bè mś
 he - inc. - beats - me
 he beats me

b) è é rú mú
 he- inc. - hurts me
 he hurts me

For (21)a), I hypothesize the following underlying representation:

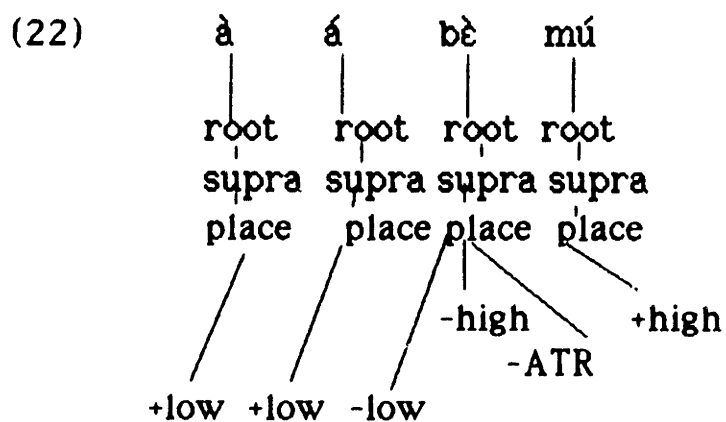

When the harmony rule applies, (22) is specified as in (23) -- remember that the redundant values are also present (I represent only the tiers that are important to us: [high], [low], and [ATR]):

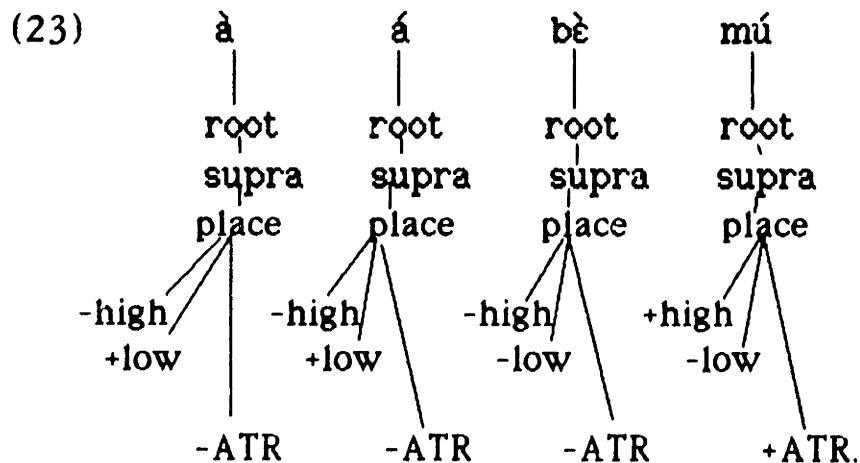

The harmony rule applies sequentially: at each step it spreads the

Let us now consider (21)b). I hypothesize that it has the following underlying representations:

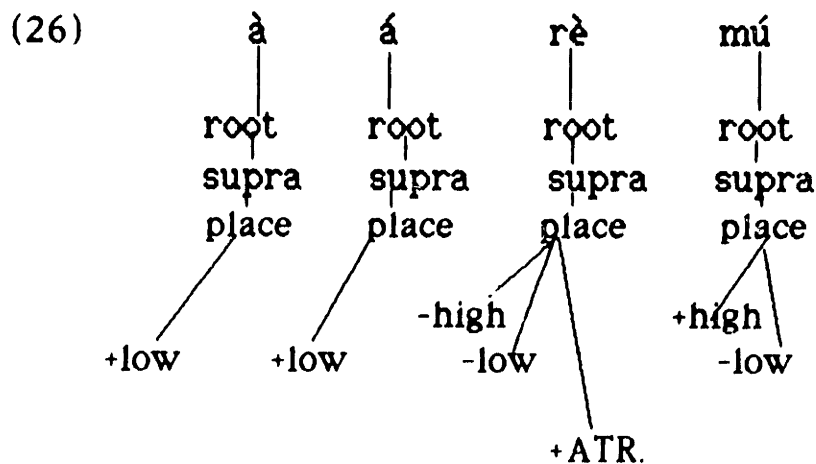

It is specified as in (27), when the harmony rule applies:

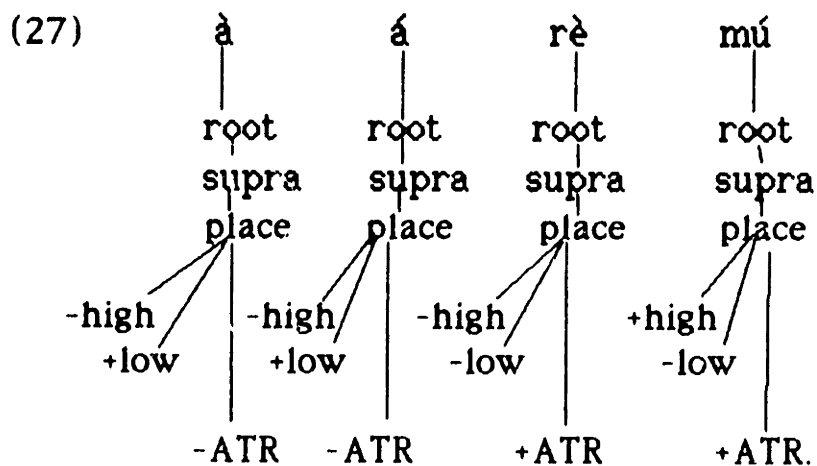

The application of the harmony rule to (27) will create the following configuration:

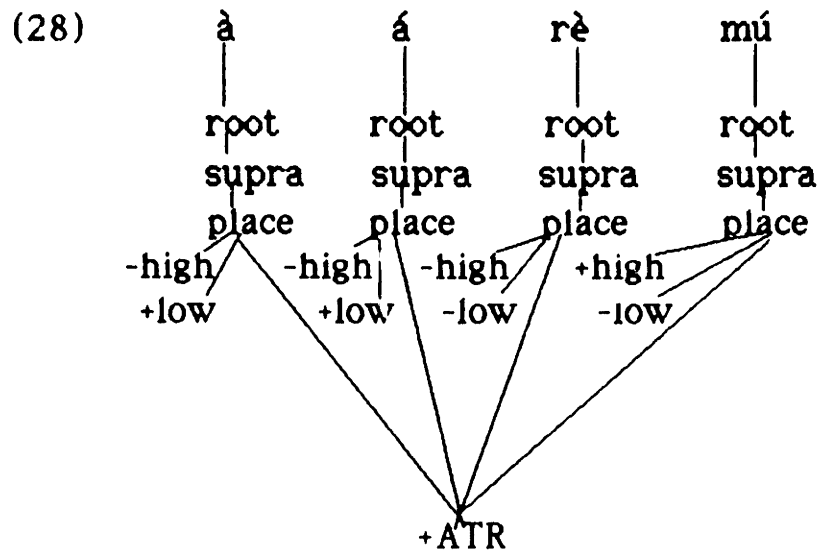

In the case of the two affixes \grave{a} and \acute{a} , we have the disallowed configuration [+low, +ATR]. I represent the feature bundle that we have obtained in this case as a feature matrix:

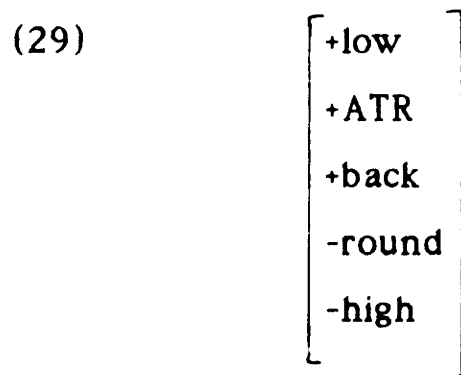

The disallowed configuration [+low, +ATR] is repaired by delinking of [+low]. We thus obtain (30):

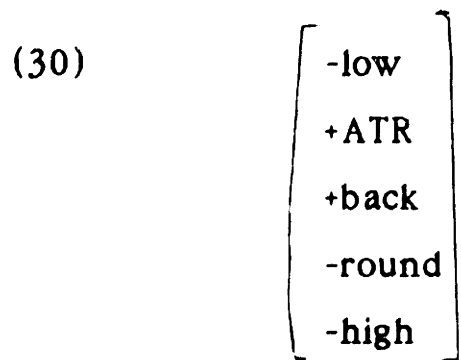

The harmony rule applies when the redundant values are all specified as in (34):

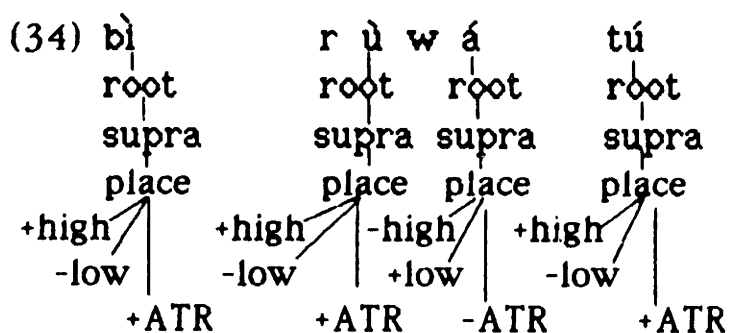

The application of the harmony rule will produce the configuration in (35):

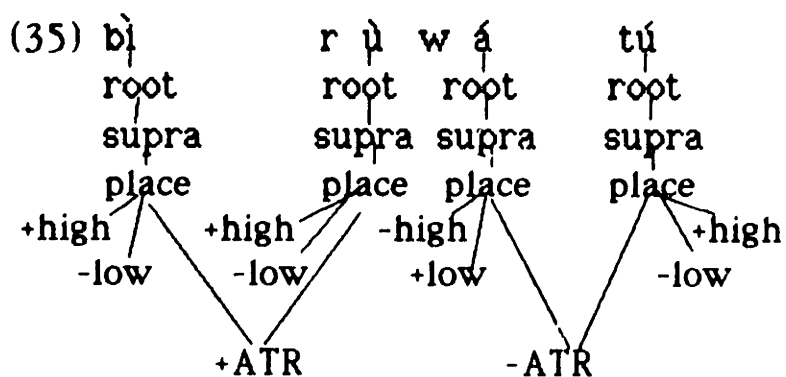

We have the disallowed configuration [+high, -ATR] in the case of the underlying affix tú. We apply delinking of [+high] as a clean-up strategy and thus obtain (36):

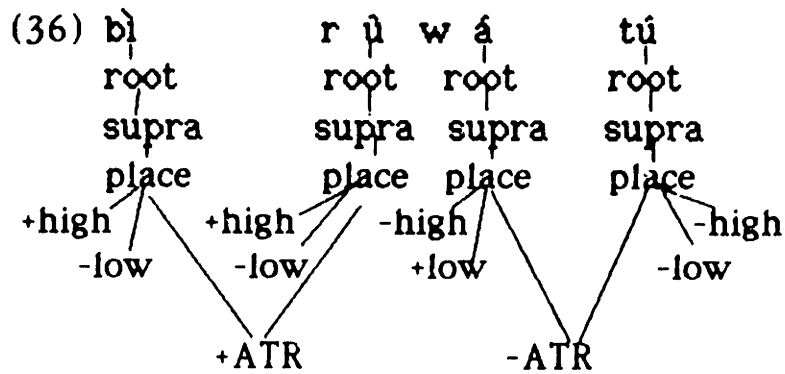

I believe that the Ogori vowel system can be nicely accounted for in my theoretical framework.^[15] Moreover, I hope to have shown that there is evidence that the prediction made by principle (1) is correct: if a rule affects redundant values by changing them into their opposite values, and thereby creating configurations in violation of underlying filters, then the redundant values were already specified when the rule was applied.

8. VOWEL HARMONY IN PALEO-SIBERIAN LANGUAGES.

Let us consider another language which appears to support principle 6.(1). This language is Chukchi, a Paleo-Siberian language spoken in Siberia.

Chukchi is reported as having a classic dominant-recessive vowel harmony (cf. Anderson (1980), Bogoraz (1922), Comrie (1981), Jakobson (1952)). The dominant vowels do not alternate. The recessive vowels undergo harmonic mutations when they appear in a word containing a dominant vowel. The series of the dominant vowel contains the vowels { e, o, a }. The series of recessive vowels contains the vowels { i, u, e }. There is also a schwa vowel that is usually inserted by epenthesis. A given morpheme in Chukchi contains either all dominant vowels or all recessive vowels (as well as possibly the vowel schwa). When morphemes are combined together into words, if the word as a whole contains at least one morpheme with dominant vowels, then all the recessive vowels are changed in the following way:

(1) i --> e, u --> o, e --> a

Observe that the direction of this harmonic change is determined only by the distinction between dominant and recessive: dominant vowels always trigger the harmonic change, regardless of whether they are in a root or an affix. In Chukchi, there is a syntactic process of incorporation by which new words can be formed. The harmonic changes also apply automatically in these new words.

Now, I wish to point out a very interesting dialectal variation. According to Bogoraz (1922) (cf. also Jakobson (1952) and Comrie (1981)), the harmonic counterparts of the recessive *i*, *u* and *e*, i.e., *e*, *o* *a*, respectively, are identical to the dominant vowels *e*, *o*, *a*. (Later I will consider the phonetic value that Bogoraz assigns to these vowels.) In contrast, Skorik (1961) (quoted by Krause (1980)) claims that there is a phonetic difference between the dominant vowels and the harmonic counterparts of the recessive vowels: the *e* derived from *i* is slightly higher and more fronted than dominant *e*, the *o* derived from *u* is slightly higher than dominant *o*, and the *a* derived from recessive *e* is slightly higher and more fronted than dominant *a*. I assume that the descriptions of Bogoraz and Skorik are both accurate, and conclude that we are dealing with two different dialects.

I shall discuss both dialects and propose a tentative explanation of the way in which they became differentiated. I will begin by discussing the dialect of Chukchi described by Skorik, which is very important for me because it gives support to the predictions made by principle (1). I will refer to it as Skorik-Chukchi (hereafter S-Chukchi). I begin my analysis of S-Chukchi by establishing the phonetic value of its vowels. I will rely on Kenstowicz (1979)'s interpretation of Skorik's description (however, see Krause (1980) for a criticism of Kenstowicz's interpretation and for a different proposal.) Kenstowicz proposes the following: recessive *i*, *u* and dominant *a* are phonetically [i], [u], and [a], respectively. The *e* derived from *i*, recessive *e*, and the *o* derived from *u* are all [+ATR] mid-vowels. The *a* derived from recessive *e* is

the [-ATR] mid-vowel [ɛ], and dominant *o* is phonetically the [-ATR] mid-vowel [ɔ]. He assumes then that dominant *e* is the low front vowel [æ]. This last assumption is problematic. Given what Skorik says, one would be tempted to say that this vowel should actually be [ɛ]. But then it should be identical to the [ɛ] derived from recessive *e*. I was not able to consult Skorik's grammar; therefore, I could not check this point. It could be that these two vowels are actually phonetically identical, but that Skorik considers them distinct for morphophonemic reasons. But this would be very strange. I thus assume that Kenstowicz's proposal of interpreting dominant *e* as [æ] is correct.

S-Chukchi's vowel system should therefore be that shown in (2) (harmonic changes are represented with arrows; dominant vowels are circled):

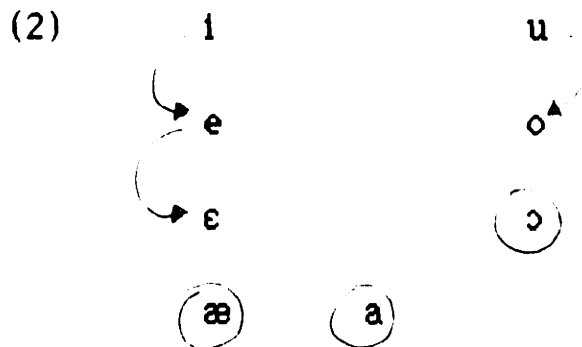

Observe that the vowels [ɛ] and [ɔ] appear only as allophonic variants of /e/ and /u/, respectively, in the environment of a dominant vowel. Therefore, the underlying vowel system of S-Chukchi is that in (3):

(3) i u
 e
 o
 æ a

The vowels are fully specified as in (4):

(4)		i	e	æ	a	o	u
	high	+	-	-	-	-	+
	low	-	-	+	+	-	-
	back	-	-	-	+	+	+
	round	-	-	-	-	+	+
	ATR	+	+	-	-	-	+

In the vowel system of S-Chukchi, the UG filters 1.(1)I), II) III) are underlyingly violated. The remaining UG filters are thus underlying filters of this system. The underlying filter 1.(1)V)b) is of crucial importance in my analysis, so I shall repeat it as (5):

(5) * [+high, -ATR].

I will now give a series of examples. Given the preceding interpretation of the S-Chukchi vowel system, we can say that the three recessive vowels { i, u, e } undergo the following mutations when they appear in a word containing a dominant vowel: i -> e , u -> o, e -> ε. Remember that the schwa vowel does not experience any harmonic mutations. It

can be inserted by epenthesis.

The Chukchi vowel harmony is bidirectional: the recessive vowels in the affixes change if the dominant values are in the root and the recessive values in the root change if the dominant vowels are in the affixes. In (6)a, I give examples with recessive vowels in affixes and dominant vowels in the root.

(6)a	<u>abs.pl. / -ti/</u>	<u>verbalizing / -tku/</u>
	tintin -ti 'ice'	rəpe-tku-k 'to hammer'
	mukəl-ti 'button'	(cf. rəpe-nə 'hammer')
	ener-ti 'star'	wil-ətku-k 'to trade'
	məməl-te 'seal'	(cf. wilwil 'price')
	qʔawal-te 'corner'	wəpa-tko-k 'to shovel'
	ɔcc-te 'leader'	(cf. wəpa-t 'shovels')
		panr-ətko-k 'to attack'
		(cf. panr-ək 'to fall on')
	<u>instr. /-te/</u>	<u>past II /ge-root-lin/</u>
	titi-te 'needle'	ge-nwit-lin 'stop'
	ekke-te 'son'	ge-gnu-lin 'be needless'
	milute-te 'hare'	ge-jne-lin 'transport'
	wəpa-te 'shovel'	ge-panr-əlen 'fall on'
	qɔra-te 'reindeer'	ge-wjat-len 'unharness'
		ge-jn -len 'sniff'

In (6)b), I give examples with recessive vowels in the root and dominant vowels in the affixes:

(6)b)	keli-k	'to write'	kele-ɟ	'written'
	eɟp-ək	'to close'	ɛɟp-əɟ	'closed'
	tip-ək	'to poke through'	teɟp-ɟ	'poked through'

<u>abs.sg.</u>	<u>comitative</u> /ge-root- ma/	
titi-nə	ge-tete-ma	'needle'
rʔew	ge-rʔew-ma	'whale'
milut	ge-melotɛ-ma	'hare'

Following Kenstowicz (1979), I will hypothesize that the feature [-ATR] is the crucial feature which defines the class of the dominant vowels is. This is the only feature common to all the dominant vowels /æ/, /a/ and /ɔ/. If this is correct, it is possible to propose an autosegmental treatment of this harmony system: this would consist in spreading of [-ATR].

Observe that no other feature value is common to the dominant vowels. Therefore any other way of characterizing the class of the dominant vowels should use more features. We would thus not be able to account for the harmony of S-Chukchi with a simple autosegmental rule. Instead, we would have to hypothesize either a spreading of more

than one node or a segmental rule that affects more features. Either hypothesis would complicate the grammar of S-Chukchi.

If the harmony rule of S-Chukchi consists in the spreading of [-ATR], we explain why we obtain [-ATR] mid [ɛ], when the rule applies to recessive [+ATR] mid /e/. However, we must account for the outputs of the rule when it applies to recessive /i/ and /u/. Recessive /i/ and /u/ are changed into mid [+ATR] /e/ and /o/, respectively. Given the harmony rule that I am hypothesizing, we obtain [-ATR] high vowels when this rule applies to /i/ and /u/. These vowels have the configuration [+high, -ATR] which is blocked by the underlying filter (5). Thus, we have to apply a clean-up rule to repair the disallowed configuration. It is evident that the clean up rule which is applied in this case is negation. Therefore, given the disallowed configuration in (7) a) produced by application of the harmony rule to recessive /i/ and /e/, we have the repair in (7) b);

(7) a) [+high, -ATR]

b) -([+high, -ATR]) -> [-high, +ATR]

In this way, I can explain why we get /e/ and /o/ from /i/ and /u/, respectively, when the latter undergo the harmony rule in S-Chukchi.[16]

Before discussing this analysis in more detail, I must discuss a

crucial point. When the harmony rule of S-Chukchi applies to the feature bundles of /i/ and /u/, it assigns to them the feature value [-ATR] which is the opposite of the feature value [+ATR] redundant in them. In this way, it produces a configuration that violates an underlying filter. If principle 6.(1) is correct, we have to assume that this redundant value was already specified when the rule applied. If it were not, then the rule should have been blocked according to principle (1). Now it is very simple to show that when the harmony rule applies, the redundant feature value [+ATR] must already be specified in the feature bundle of /i/ and /u/. I have observed that Chukchi morphemes must contain either all dominant vowels or all recessive vowels. In S-Chukchi, as discussed above, the dominant vowels are all [-ATR]. Recessive vowels, in contrast, are all [+ATR]. Therefore, we need a morpheme structure condition which can account for this striking characteristic of S-Chukchi (When I discuss the Chukchi dialect described by Bogoraz, I will propose a diachronical explanation of this property of S-Chukchi morphemes). I hypothesize that this morpheme structure condition is the following:

$$\begin{array}{l}
 (8) \text{ If: } \quad \begin{array}{c} \text{N} \\ \downarrow \\ [\dots \text{X} \dots] \end{array} \quad \begin{array}{c} \text{N} \\ \downarrow \\ \text{X} \dots] \end{array} \\
 \text{then: } \quad \alpha\text{ATR} \quad \alpha\text{ATR}
 \end{array}$$

(8) states that all S-Chukchi morphemes must contain vowels with the same [ATR] value. Observe that (8) cannot hold for words, since it would be violated by words which contain morphemes with recessive /i/ and /u/ and morphemes with dominant vowels. In these words, in

fact, the harmonic counterparts of /i/ and /u/ are [+ATR] /e/ and [o]. Therefore, (8) does not overlap with the harmony rule and must be kept clearly distinct from it.

(8) holds for underlying representations, since a morpheme with the recessive vowels /i/ (or /u/) and /e/ will contain [+ATR] /e/ (or [o]) and [-ATR] [ɛ] in surface representations when it is in a word which contains dominant vowels. We are then forced to say that the feature value [+ATR] is underlyingly specified in the feature bundles of /i/ and /u/, although it is redundant there. If the feature value [ATR] were not underlyingly specified in the feature bundles of /i/ and /u/, we would expect to find morphemes that underlyingly contain /i/ and/or /u/ together with a dominant vowel, because (8) could not be sensitive to their unspecified value [+ATR]. The presence of a dominant vowel in these morphemes would then trigger the application of the harmony rule; therefore underlying /i/ and /u/ would be changed to surface [e] and [o], respectively, in these morphemes. Thus, we would expect to find morphemes that superficially contain [e] and/or [o] together with a dominant vowel. But this is not the case. In S-Chukchi, there are no morphemes with this combination of vowels. All morphemes of S-Chukchi contain either vowels from the set (i, u, e) or vowels from the set (æ, a, ɔ). To explain this striking characteristic of S-Chukchi, we must hypothesize that there is a morpheme structure condition like that in (8), and that the feature [ATR] is underlyingly specified in all vowels. In particular, [+ATR] must be underlyingly specified in the feature bundles of /i/ and /u/.

It is obvious then that the feature value [+ATR] is already specified in the feature bundle of /i/ and /u/ when the harmony rule applies. This is what we expect given principle 6.(1). I can now formulate the harmony rule of S-Chukchi as the feature-changing rule in (9):

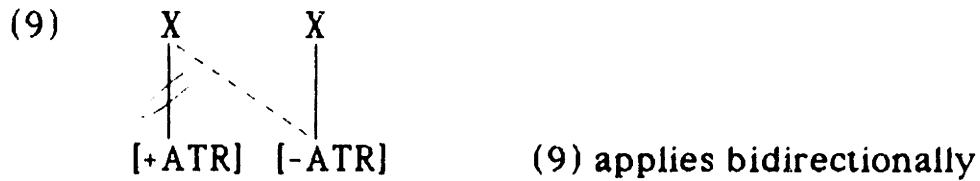

(9) is iterative. The feature bundles to which it applies are fully specified.

Let's now consider what happens when rule (9) applies. If its target is the vowel /e/, i.e.,

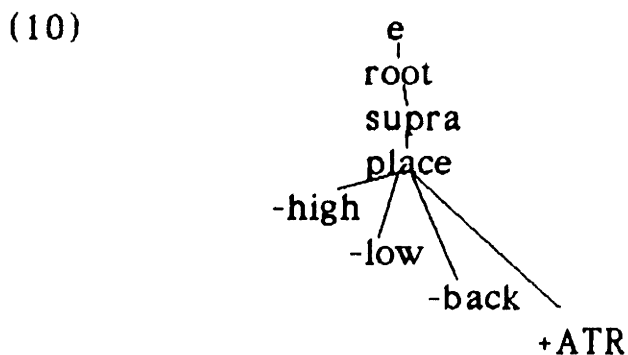

we will obtain the following configuration:

(11)

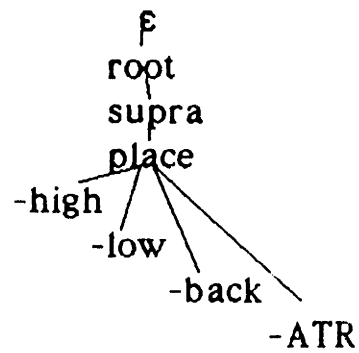

This is the vowel [ɛ]. [ɛ] is not blocked by any underlying filter, even if it is not present in the vowel system of S-Chukchi (In Chapter 3 I will discuss the theoretical status of situations like this in which the absence of a segment from an inventory cannot be accounted for by an underlying UG filter).

If the target of (9) is the vowel /i/ , i.e.,

(12)

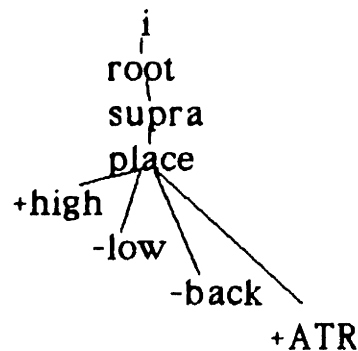

we will obtain the configuration in (13):

(13)

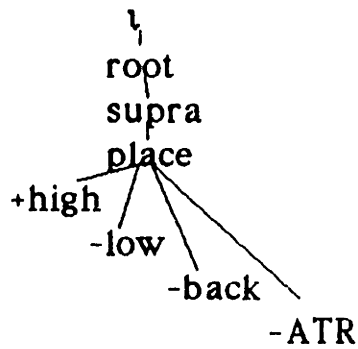

In (13), we have a configuration blocked by filter (5). Therefore, we have to clean it up. I propose that negation applies in this case as a clean up rule. The incompatible features in (13) are [+high] and [-ATR]. By applying the negation rule to them, we obtain the following feature bundle:

(14)

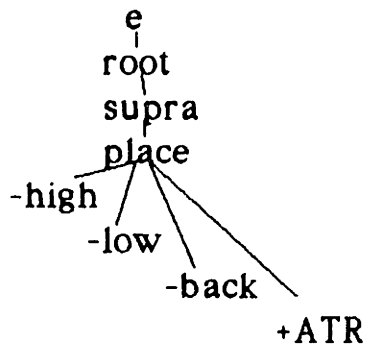

This is the feature bundle associated with the vowel /e/. We can thus understand why the vowel /i/ in Chukchi is changed into /e/ in a harmonic environment.

The same process holds for the vowel /u/. When it is the target of the harmony rule, we obtain the following configuration:

(15)

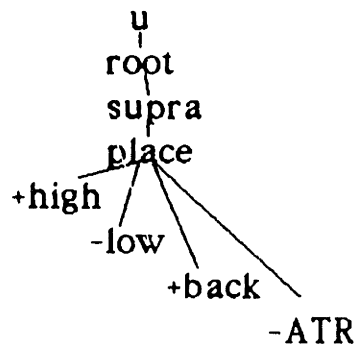

In (15), we have the disallowed configuration [+high, -ATR], which must be cleaned up. If we apply the negation rule, as we did for /i/, we will obtain the following configuration:

(16)

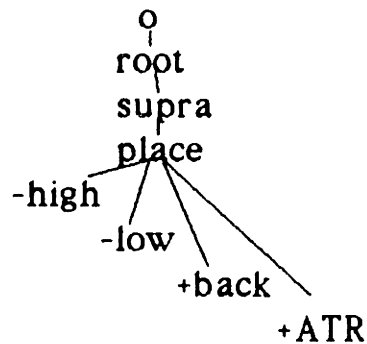

This is the feature bundle of the vowel [o]. Thus we can explain why /u/ is changed into [o] in a harmonic environment. Note that the vowel [o] is not blocked by an underlying filter, despite the fact that it is not present in the underlying vocalic system of Chukchi. (see Chapter 3 for discussion of the case in which absence of segments from a phonological inventory cannot be accounted for by an underlying UG filter.) .

I will give a sample derivation: I shall consider how the comitative ge-melote-ma is derived from the root milute 'hare' (I represent only the tiers that are important to us here). Before the

harmony rule in (9) applies, we have the following representations:

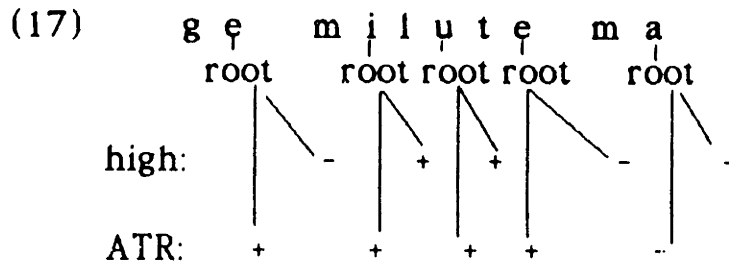

The application of rule (9) is iterative. We thus have the following steps.

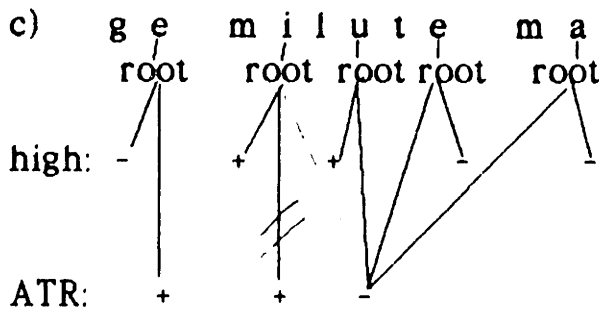
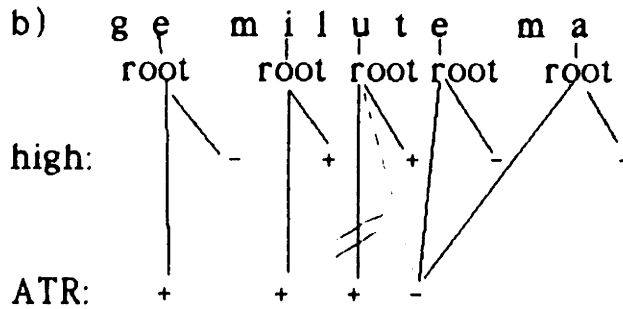
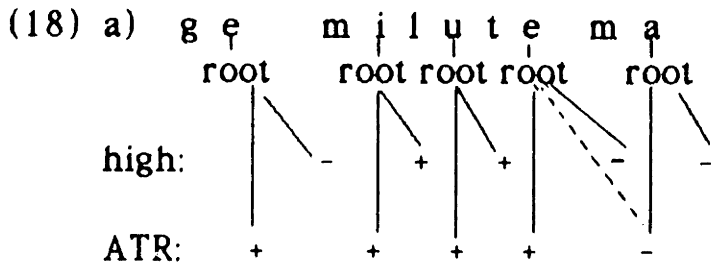

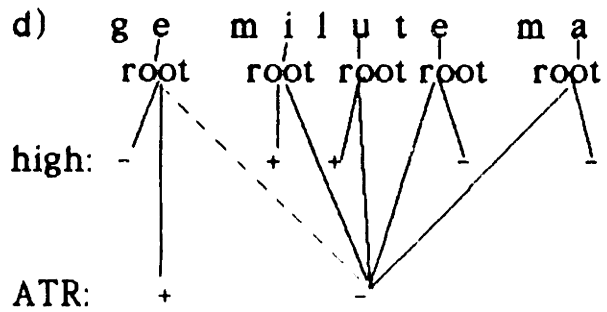

We will then obtain the following configuration:

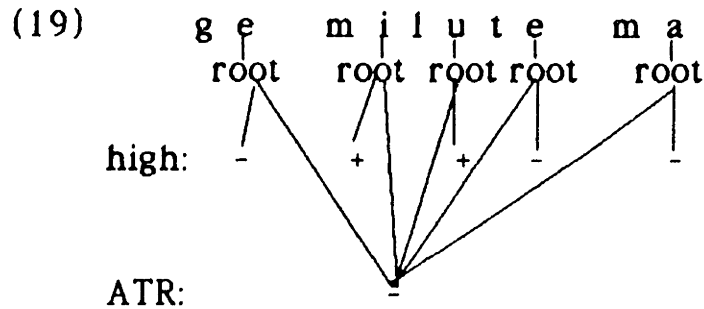

In (19) we have the disallowed configuration [+high, -ATR] in the case of the two high vowels of the root. Therefore, negation must be applied as a clean up strategy. Rule (10) of Section 5 must apply to allow the application of the clean-up rule:

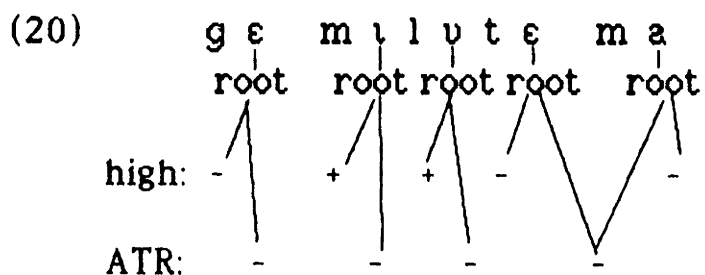

The [-ATR] value associated with the first vowel of the word must also be affected by the rule 5.(10) to prevent crossing of association lines. Negation then applies to repair the configurations that violate the filter

*[+high, -ATR] and we get (21):

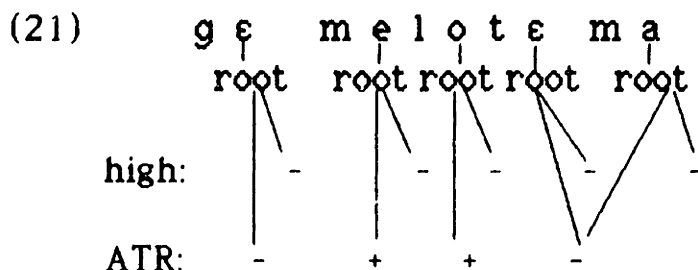

The form gɛ melote ma is thus derived.

In Chukchi, there is a vocalic segment that seems to be transparent neutral: the schwa vowel ə. As mentioned, ə is the epenthetic vowel of Chukchi; we see this in the following alternations:

abs.sg.	abs.pl.
(22) a) imət	b) imti-t "load"
ekək	ekke-t "son"
lɔnəl	lɔnla-t "walrus fat"

There is a rule which deletes the final stem vowel in Chukchi. Therefore, the vowels that we see in the corresponding forms of (22)b) have been deleted in the forms in (22)a). Thus, in the forms in (22)a) we have a final consonantal cluster CC##, which is impossible in Chukchi. Therefore, we must insert the epenthetic vowel ə (For a more thorough analysis of epenthesis in Chukchi cf. Kenstowicz (1979)). Epenthetic ə is not modified in a harmonic environment, as we can see in lɔnəl or in tip-ək where the ə is not affected by harmony in any

way. This is what we expect, however, if we hypothesize that epenthesis applies after harmony.

There are, however, cases in which the schwa does not appear to be inserted by epenthesis. Consider the following pair, for example:

	abs.sg.	abs.pl.	
(23)	a) mæməl	b) mæməl-te	"seal"

(23)a) cannot be derived from a form like mæmV, because we would see this form in (23)b); thus, we must suppose that ə is not inserted by epenthesis. Now, ə in (23) is not affected by the presence of the dominant vowel /a/, and it does not interfere with the spreading of the harmonic feature to the suffixal vowel. It is possible to see that ə does not interfere with the harmony rule by comparing (23)b) with (24), where the suffix -ti undergoes harmonic change:

	abs.sg.	abs.pl.	
(24)	tintin	tintin-ti	'ice'
	ener	ener-ti	'star'
	ɔccɔc	ɔccɔc-te	'leader'
	qʔawal	qʔawal-te	'corner'

A case of non-inserted ə in a non-harmonic environment is presented in (25):

	abs.sg.	abs.pl.	
(25)	mukəl	mukəl-ti	"button"

Therefore, the vowel ə of (23) and (25) seems to behave like a neutral vowel. If this is true, we have an example which contradicts my idea that we should find neutral segments in a vowel harmony system when harmony the rule applies to feature bundles with unspecified redundant values and assigns a value which is the opposite of one of these values.

However, non inserted schwas have strange properties. Kenstowicz (1979) observes the following fact: "*[It is] necessary to recognize a +/- [ATR] contrast for underlying schwa vowels in the roots of forms like /təlg/ "thaw" and /pəlm/ "dark": cf. təlgətət "a thaw", təlg-ət-ək "to get warm", versus pəlməpəl "darkness", pəlm-ət-ək "to get dark". The schwa in these roots never alternates with zero and thus is most properly considered part of the underlying form. Nevertheless, /pəlm/ triggers the harmonic change of /-ət/ to /-et/, while /təlg/ does not. Since, as far as I know, schwas do not exhibit any phonetic difference in təlgətət versus pəlməpəl, a phonological rule neutralizing the underlying +/-[ATR] contrast will be required.*" (Kenstowicz (1979) p.410)

This means that non-epenthetic ə cannot be considered to be a neutral vowel. Given what Kenstowicz claims, the non-inserted ə seems to be the superficial merging of two vowels: one that belongs to the

recessive class, e.g., the underlying vowel in /təlg/, and one that belongs to the dominant class, e.g., the underlying vowel in /pəlm/. We could hypothesize that non-epenthetic ə is the result of a rule of vowel reduction which merges two different vowels. However, I cannot provide data to argue this hypothesis here. As a final point, I want to suggest that the underlying vowel of the second syllable of the root in (23) is either a recessive vowel harmonized with the dominant vowel of the first syllable, or simply a dominant vowel. Clearly, it is not a neutral vowel.

Let us now consider the dialect of Chukchi described by Bogoraz (1922). I will refer to it as Bogoraz-Chukchi (hereafter B-Chukchi). As I said before, in B-Chukchi, the harmonic counterparts of recessive vowels are identical to the dominant vowels. As in S-Chukchi, morphemes must contain either all dominant vowels or all recessive vowels. B-Chukchi differs from S-Chukchi in that an entire word must contain either all dominant vowels or all recessive vowels, given the identity between dominant vowels and the harmonic counterparts of recessive vowels.

What is the phonetic value of B-Chukchi vowels? If I interpret Bogoraz's transcription correctly, recessive *i* and *u* and dominant *a* and *e* have their normal phonetic value; recessive *e* is a [+ATR] mid vowel; dominant *e* and *o* are mid [-ATR] ϵ and ɔ . Therefore, the recessive vowels are phonetically (i, u, e); the dominant vowels are (ϵ , ɔ , a) when they are in a word that contains dominant vowels. The

The problem is now that of accounting for the different surface vowels of B-Chukchi. I propose that in B-Chukchi, as in S-Chukchi, [ATR] is the key feature in understanding the harmony system. I hypothesize, however, that in B-Chukchi, the feature [ATR] is not only specified on the phonological plane of the segmental melody, but that it is also specified on an autonomous morphological plane (see Note 13 for a similar proposal for Ogori following Cole (1987)). I assume that each morpheme in B-Chukchi has this plane, and that only one value for [ATR] is specified on this plane for each morpheme. This value is finally spread onto the feature bundles of the vowels contained in the morpheme. Observe that this spreading can be considered to be a case of tier conflation (see Cole (1987)). I represent this rule of spreading in (29). I assume that given a morpheme M, the rule spreads the morphological [ATR] value associated with \dot{M} onto the feature bundles of the vowels in M thereby delinking the phonological [ATR] value present there:

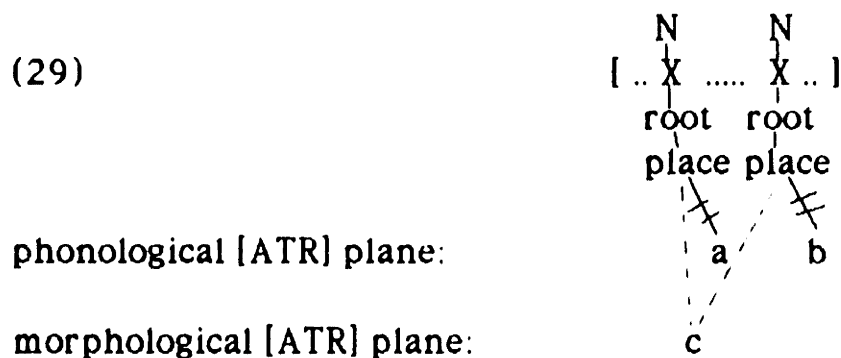

I will call the [ATR] value specified on the morphological plane the morphological [ATR] value.

It is evident that I assume that each morpheme underlyingly contains only the vowels /i/, /u/, /a/. Let us consider a morpheme that has the morphological feature value [-ATR]. If this morpheme contains the underlying vowels /i/ and /u/, when this morphological [-ATR] is spread onto their feature bundles, we will obtain the configuration [+high, -ATR] disallowed by the underlying filter (27). A clean up rule must be applied to repair this configuration. Delinking of [+high] is the strategy chosen. Therefore, we obtain the configuration [-high, -ATR]. In this way, the underlying /i/, /u/ surface as [ɛ] and [ɔ], respectively, in a [-ATR] morpheme. Let us suppose that this morpheme contains the underlying vowel /a/. When the morphological feature value [-ATR] is spread onto its feature bundle, it will not create a disallowed configuration. Therefore, the underlying /a/ surfaces as [a] in a [-ATR] morpheme.

Let us consider a morpheme that has the morphological feature value [+ATR]. If it contains the vowels /i/ and /u/, no disallowed configuration will be formed when this morphological [+ATR] is spread. Therefore, underlying /i/, /u/ surface as [i] and [u], respectively, in a [+ATR] morpheme. If the morpheme contains underlying /a/, when the morphological [+ATR] is spread onto its feature bundle we obtain the configuration [+low, +ATR], which is disallowed by the underlying filter in (28). A clean up rule must then be applied. Delinking of [+low] is chosen, and we thus obtain the configuration [-low, +ATR]. At this point, as in the similar case of Ogori (see Section 7), another clean up rule must be applied, since we have the configuration [+back, -round,

-low] disallowed by the underlying filter *[+back, -round]/[____, -low] in the feature bundle obtained by delinking of [+low]. Delinking of [+back] is applied and thus we get the feature bundle of /e/. Therefore, underlying /a/ surfaces as [e] in a [+ATR] morpheme. (Observe that in the variety of Chukchi described by Jakobson (1952), the counterpart of this [e] is [ə]. We can explain this fact by hypothesizing that delinking of [+back] is not applied in this variety.) In this way, I can account for the different surface phonetic vowels of B-Chukchi.

Observe that in the preceding analysis, it has been assumed that the feature value for [ATR] of the phonological segments is already specified when the morphological [ATR] value is spread. This is what is required by principle 6.(1). In fact, if the phonological [ATR] value were not specified in the feature bundle of /i/, /u/, and /a/, the spreading would be blocked by this principle.

Observe then that in B-Chukchi the application of the clean up rules produces configurations of features which violate an underlying filter of this language. In fact, the cleaning up of the disallowed configurations [+low, +ATR], [+high, -ATR] by delinking of [+low] and [+high], respectively, creates mid-vowels. Now, mid-vowels are underlying absent in B-Chukchi. This means that the UG filter *[-high, -low] is underlying in this language. In Section 11, similar cases will be discussed. The point, as we will see in that Section, is that the function of the clean up rules is not that of preserving the underlying inventory of segments by eliminating all of the configurations of features

disallowed by underlying filters that can appear in the course of the phonological derivation, but that of decreasing the markedness of a phonological system. The markedness of a phonological system is increased only when configurations of features in violation of underlying filters that are in high positions in the UG filter hierarchy are produced. The creation of configurations of features in violation of underlying filters at a low position in the hierarchy does not cause an increase in the markedness of the system. Therefore, if a configuration of feature of a certain feature bundle violates an underlying filter at a high position in the filter hierarchy, we might expect that a clean up rule repairs this configuration by changing it in such a way that a configuration of features in violation of an underlying filter at a lower position in the hierarchy is formed in that feature bundle. This is what happens in B-Chukchi, where, for example, the configuration [+high, -ATR] that violates the filter (27) is repaired by delinking of [+high]. In this way, we obtain a feature bundle with the configuration [-high, -low], which violates the filter *[-high, -low] at a much lower position than (27) in the UG filter hierarchy.

Let us consider the vowel harmony rule of B-Chukchi. I would like to propose that this rule is different from the one I proposed for S-Chukchi, only in that the harmony rule applies on the morphological [ATR] tier. We can formulate the rule as in (30):

b) Phon. [ATR] plane

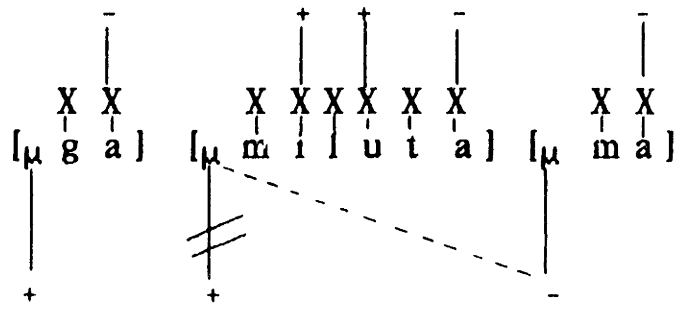

c) Phon. [ATR] plane

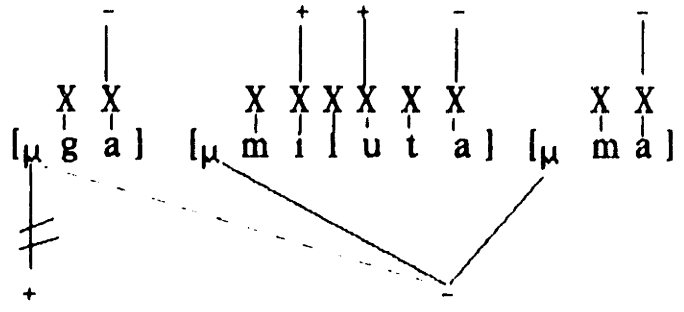

d) Phon. [ATR] plane

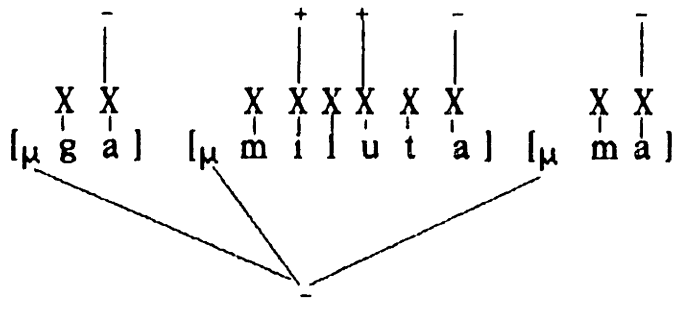

After the harmony rule is applied, rule (29) spreads the morphological [ATR] value from the morphological [ATR] plane onto the phonological [ATR] plane. (I consider only the phonological tiers that are pertinent to the discussion here):

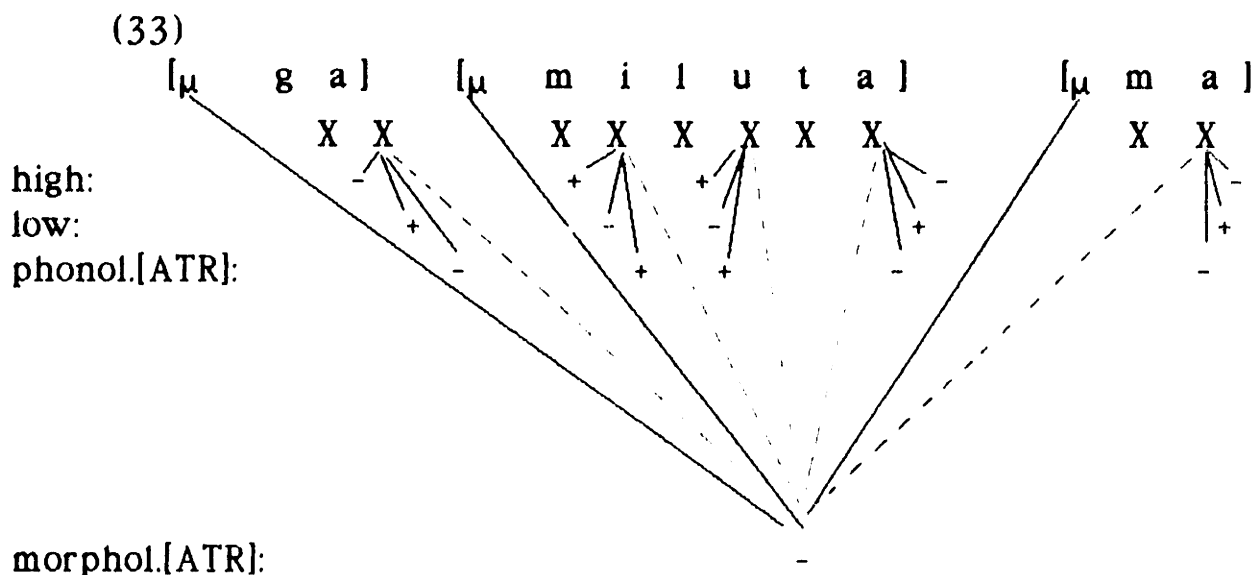

Disallowed configurations are formed in the case of the underlying /i/ and /u/ of miluta. Delinking of [+high] applies and therefore we obtain

(34):

(34)

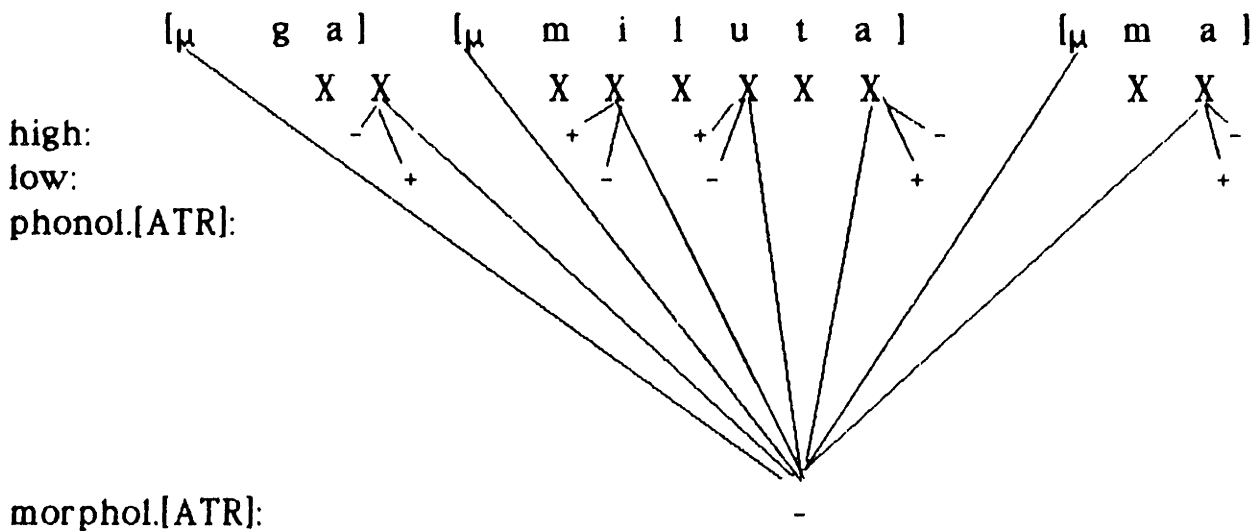

At this point, I would like to attempt an analysis of the reasons for the dialectal differentiation between S-Chukchi and B-Chukchi. I hypothesize that these two dialects stemmed from two varieties of the

same "proto-language." One variety was identical to B-Chukchi. The other differed only in the fact that the clean up rule used to repair the configurations [+high, -ATR] created by spreading morphological [-ATR] onto the feature bundle of high vowels was negation, not delinking of [+high]. Therefore, this second dialect had [i], [u], [e] as recessive vowels and [e], [o], [a] as dominant vowels or harmonic counterparts of the recessive vowels. Observe that among the dialects of Koryak, a sister language of Chukchi, there appears to be a dialect that has precisely this system. This is the Koryak of Paren, if my interpretation of Bogoraz (1922) is correct. I propose that the variety of "Proto-Chukchi" which used negation was the ancestor of S-Chukchi. I hypothesize that another change also occurred in this variety: the morphological [ATR] plane was lost and the surface vowels of this variety were interpreted as having the morphological [ATR] value of the morpheme in which they occurred, instead of their phonological [ATR] value. In this way, the harmony rule (which was unchanged) became sensitive only to phonological [-ATR] values, and it was triggered by the [-ATR] vowels obtained by this historical change. This brought about a restructuring of the underlying vowel system: the surface vowels of "dominant" morphemes, i.e., morphemes that were specified as [-ATR] in the morphological [ATR] plane in the older system, were interpreted as underlyingly [-ATR], and the surface vowels of "recessive" morphemes, i.e., morphemes that were associated with [+ATR], were interpreted as underlyingly [+ATR]. [17] Therefore, we obtained the vowel system in (35):

(35)

i	u
e	
ε	ɔ
	a

The clean up strategy used to repair the disallowed configurations produced by the harmony rule when it applied to high vowels was not changed. And therefore, [+ATR] [e] and [ɔ] continued to be the harmonic counterparts of recessive /i/ and /u/. The restructuring in (35), however, produced an important change: [e]--which was an allophone of /a/ in a [+ATR] morpheme--became an underlying recessive vowel. At this point, when it was a target of the harmony rule, it was simply changed to [ε].

In (36), I present the various surface vowels of this variety of Chukchi. The dominant vowels are circled and the harmonic changes of the recessive vowels are indicated by arrows:

(36)

i	u
e	[ɔ]
ε	ɔ
	a

To obtain S-Chukchi, we need a rule that lowers dominant /ε/. I have already observed that I have some doubts about the fact that there is a real phonetic difference between dominant e and the harmonic

counterpart of *e* besides the clear morphophonemic difference. However, I can suppose that it is this latter difference that leads to a phonetic differentiation of the two vowels: in particular, I hypothesize that the underlying dominant vowel /*ε*/ was interpreted as polarized towards a lower position. Thus (36) was changed into (37):

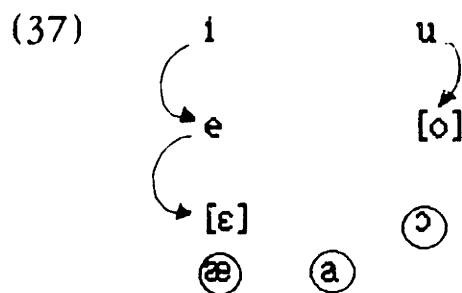

Observe that we now have an explanation of the morpheme structure condition (8) of S-Chukchi. It is a consequence of the fact that the morphological [ATR] value associated with each morpheme of the proto-language (as well as of B-Chukchi) is now reflected in the phonological [ATR] value of the vowels contained in that morpheme. This implies that all the vowels of a given morpheme must have an identical [ATR] value.

8.1 KORYAK AND NEZ PERCE

There is a dialect of Koryak, the Koryak of Kamenskoye (see Bogoraz (1922)), which differs from the two dialects of Chukchi discussed above in an interesting way. In the Koryak of Kamenskoye, the vowel [a] belongs both to the recessive and the dominant series and

therefore does not alternate. Putting aside the case of [a], the harmony system of Koryak of Kamenskoye is similar to that of B-Cukchi: the harmonic counterparts of recessive *i* and *u*, i.e., *e* and *o*, respectively, are identical to dominant *e* and *o*. If I interpret Bogoraz (1922) correctly, the vowels *e* and *o* of the Koryak of Kamenskoye are phonetically mid [+ATR] vowels, as in the Koryak of Paren mentioned above. Therefore the Koryak of Kamenskoye has the following two vocalic series: recessive (*i*, *u*, *a*) and dominant (*e*, *o*, *a*). The recessive vowels change in the following way when they are in a word with a morpheme with dominant vowels: *i* --> *e*, *u* --> *o*, *a* --> *a*.

Thus in the Koryak of Kamenskoye, the vowel [a] seems to be neutral. This would lead to a very interesting problem. According to principle 6.(1), in fact, the harmonic change of recessive [i] and [u] can be explained only if the harmony rule applies when the redundant values are already specified. At the same time, principle 6.(1) states that neutral vowels are possible only in vowel harmony systems in which the harmony rule applies before the redundant values are filled in. Therefore, in the Koryak of Kamenskoye, we would have a situation in which the harmony rule applies at the same time to a feature bundle with an unspecified redundant value -- in the case of /a/ -- and to feature bundles with specified redundant values -- in the case of /i/ and /u/. As we will see in Chapter 2, I believe this situation is not possible because I hypothesize that all redundant values are specified at the same time and that there is no ordering of R-rules.

Observe now that it is not correct to consider /a/ to be a real

neutral vowel. There is clearly a dominant [a], as we can see in the following morphemes, which triggers the harmonic change of the recessive vowels (examples from Bogoraz (1922)):

(1) a) *evəl* - *tamtam* 'long tumor' (from the stems *ivəl*
'long' and *tamtam* 'tumor')

b) *qatap* -*emat* 'load of food for winter use' (from the
stems *qatap* 'fish for winter use' and *imt* 'load')

The point is that in the Koryak of Kamenskoye, as in the Koryak of Paren and in B-Chukchi, the harmonic [ATR] value is not a property of phonological segments, but of morphemes, as is shown by the identity between the dominant vowels [e] and [o] and the [e] and [o] harmonic counterpart of recessive [i] and [u].

If my analysis of B-Chukchi is correct, I am led to conclude that we also have the underlying three vowel system /i, u, a/ in the Koryak of Kamenskoye. When underlying /i/ and /u/ are in a [+ATR] morpheme, they surface as [i] and [u]. When they are in a [-ATR] morpheme or in a word that contains a [-ATR] morpheme, they surface as the mid [+ATR] [e] and [o] by negation of the disallowed configuration [+high, -ATR] created by the spreading of morphological [-ATR] onto their feature bundle. Recall that according to principle 6.(1), in order to obtain this derivation, the redundant value [+ATR] must already be specified in the feature bundle of /i/ and /u/ when spreading applies.

What about underlying /a/? When it is in a [-ATR] morpheme or in a word with a [-ATR] morpheme, it surfaces unchanged, as in B-Chukchi and in the Koryak of Paren. When it is in a [+ATR] morpheme, we have a problem since it is not changed to [e] as it is in B-Chukchi or in the Koryak of Paren. I could assume that the redundant value [-ATR] is not specified in the feature bundle of /a/, and that therefore principle 6.(1) prevents the spreading of morphological [ATR] to this feature bundle. In this case I should assume that redundant values can be specified at different points of the derivation. This is something that I believe is impossible. In contrast, I assume that the redundant value [-ATR] is specified in the feature bundle of /a/ when spreading applies. I assume then that the spreading of morphological [+ATR] creates the disallowed configuration [+low, +ATR] and delinking of [+ATR] applies to repair this configuration. In this way, we again obtain the configuration [+low, -ATR] of /a/. Thus underlying /a/ surfaces unchanged as [a] in [+ATR] morphemes.

In Section 5., I proposed that if delinking of a feature value assigned by a rule to a feature bundle results in a value that is redundant in that feature bundle, the Derivational Simplicity Criterion ((21) of Section 5) requires a reanalysis in which the rule applies to a feature bundle unspecified for that value. In this way, the rule cannot apply to this feature bundle by principle 6.(1). The unspecified feature value will be filled in later by the appropriate R-rule.

Observe now that the DSC cannot lead to a reanalysis of the

derivation of recessive [a] that involves just two steps: 1) blockage of the spreading of morphological [+ATR] to the unspecified feature bundle of underlying /a/; 2) successive application of the R-rule: [+low] --> [-ATR]. In fact, this would have the consequence that the R-rule which fills in the value [-ATR] in the feature bundle of /a/ would apply at a point in the phonological derivation different from the point in which the R-rule that fills in [+ATR] in the feature bundles of /i/ and /u/ applies. I believe that ordering of R-rules is impossible in principle, and suppose that they always apply *en bloc*. It is obvious that the DSC cannot impose incorrect derivations. Therefore it does not hold in this case. Thus, the only possible derivation is that in which three steps are needed to derive recessive [a]: (1) filling in of redundant [-ATR]; (2) spreading of morphological [+ATR], which produces the disallowed configuration [+low, +ATR]; (3) delinking of [+ATR], which gives a configuration [+low, -ATR]. (Observe that we also need a derivation with three steps to derive dominant [e] and [o] and the harmonic counterparts of recessive [i] and [u] from underlying /i/ and /u/.)

Support for this analysis of the facts of Koryak of Kamenskoye comes from another language belonging to a completely different linguistic family with a vowel harmony system whose facts are similar to that of Koryak of Kamenskoye. This language is Nez Perce (cf. Aoki (1966), (1970), Rigsby (1965), Chomsky and Halle (1968), Kiparsky (1973) and Hall and Hall (1980))

Nez Perce, like Koryak and Chukchi, has a vowel harmony system of the dominant-recessive type. The dominant vowels are (i, o, a); the

recessive vowels are (i, u^[18], æ). As in Chukchi, the vowel harmony rule states that if any morpheme in a word has a vowel of the dominant series, then all recessive vowels in the word become dominant. The harmonic changes are the following: [i] -> [i], [u] -> [o], [æ] -> [a]. If no morpheme containing a dominant vowel is present, then naturally all vowels in the word are recessive. Morphemes whose vowels are dominant can occur as either roots or as affixes.

The peculiar characteristic of Nez Perce is that the vowel [i] is a member of both the dominant and recessive series. There are some [i]'s which behave as dominant vowels: they can occur with other dominant vowels in plurisyllabic morphemes as in tali 'short' and they can cause harmonic change of recessive vowels if they are in monosyllabic morphemes. This is shown in examples (2) and (3):

- (2) a) ʔi·c 'mother'
 b) næʔi·c 'my mother'
 c) ʔi·cæʔ 'mother!'

where the [i] is non-dominant, and in (3):

- (3) a) ci·c 'paternal aunt'
 b) naʔci·c 'my paternal aunt'
 c) ci·caʔ 'paternal aunt!'

Linguists have been fascinated by the Nez Perce vowel system because of two problems it presents. The first problem is that of describing the two morphophonemically distinct but phonetically identical *i*'s. The other problem concerns the fact that "*the set of vowels in the two classes of words -- [i, a, o] and [i, æ, u] -- are not natural classes in any reasonable phonetic framework*:" (Chomsky and Halle (1968 p.377))

I propose that the Nez Perce vowel harmony system is essentially similar to that of B-Chukchi. Namely, I propose that the underlying vowel system is composed of the vowels /i, a, u/ and that each morpheme is associated with a morphological [ATR] plane. I hypothesize that the harmony rule of Nez Perce is the same as that of B-Chukchi, i.e., it is 8.(30), and that as in B-Chukchi, the spreading of morphological [ATR] onto the feature bundles of underlying /i/, /u/, and /a/ occurs after the harmony rule is applied.

I then propose that Nez Perce and B-Chukchi differ only in which one of the clean up rules applies to repair the disallowed configurations created by spreading of morphological [ATR] onto the feature bundles of underlying /i/, /u/ and /a/.

I assume first of all, like Aoki and Kiparsky, that the surface recessive [æ] is the result of a low-level phonetic rule which causes lowering of a front mid vowel. I assume that this front mid vowel is derived from underlying /a/ in a [+ATR] morpheme in the same way as

the recessive [e] of B-Chukchi is derived: the morphological [+ATR] of a recessive morpheme is spread onto the feature bundle of underlying /a/. The disallowed configuration [+low, +ATR] is thus created and a clean up rule must then be applied. As in B-Chukchi, I propose that delinking of [+low] is applied, so that we get the configuration [-low, +ATR]. Delinking of [+back] must also apply in this case for the reasons discussed for the similar B-Chukchi case (cf. also the discussion of the same derivation in Ogori). Thus, we get [e].^[19]

When underlying /a/ is in a [-ATR] morpheme or in a word with a [-ATR] morpheme, it will surface as [a] because the morphological [-ATR] that is spread onto its feature bundle does not create a disallowed configuration. In this way, I explain why recessive [æ] is changed to [a] in Nez Perce: the underlying vowel /a/ from which it is derived can surface unchanged in a [-ATR] word.

Let us now consider underlying /u/. When it is in a [+ATR] morpheme, it can surface unchanged since the spreading of morphological [+ATR] onto its feature bundle would not create a disallowed configuration. When it is in a [-ATR] morpheme or in a word with a [-ATR] morpheme, then morphological [-ATR] would be spread onto its feature bundle and the disallowed configuration [+high, -ATR] would be created. I propose that this configuration is repaired by negation as it is in S-Chukchi or in Koryak dialects. Therefore we get the configuration [-high, +ATR] of [o]. Thus, I explain the change from recessive [u] to dominant [o].

Let us now consider underlying /i/. When it is in a [+ATR] morpheme, it can surface unchanged since the spreading of morphological [+ATR] does not create a disallowed configuration in this case. This is similar to what happens in B-Chukchi and both Koryak dialects. There is a difference, however, when underlying /i/ is in a [-ATR] morpheme. In this case, the spreading of [-ATR] onto the feature bundle of /i/ creates the disallowed configuration [+high, -ATR] which must be repaired. Nez Perce differs from B-Chukchi and the Koryak dialects in that the clean up strategy used for it is different than that used to repair the same configuration created in the case of /u/. In this case, in fact, delinking of [-ATR] is chosen instead of negation, which is chosen in the case of /u/. Therefore, underlying /i/ in a [-ATR] morpheme or in words with [-ATR] morphemes surfaces as [i] with no apparent change.

If my analysis is correct, the case of "dominant" [i] in Nez Perce is identical to the case of recessive [a] in Koryak of Kamenskoye: the spreading of morphological [ATR] to a feature bundle has created a disallowed configuration. This disallowed configuration is repaired by applying delinking of one of the incompatible feature values. Delinking of this feature value results in a feature value that is redundant in that feature bundle. In a situation like this, the DSC would require a reanalysis of the derivation by which spreading applies before the R-rules are applied. However, in the Koryak of Kamenskoye, we must assume that the R-rules have already applied in the case of the feature bundles of underlying /i/ and /u/, when the spreading occurs.

Therefore, since I hypothesize that no ordering of R-rules is possible, the DSC cannot require this reanalysis because it would lead to an ordering of the R-rules.

Now, the Nez Perce facts support the idea that no ordering of R-rules is possible. Observe, first of all, that we cannot hypothesize two different R-rules like the following

(4) [+high, -back] --> [+ATR]

(5) [+high, +back] --> [+ATR]

(4) and (5) cannot be distinguished--first, for reasons of simplicity and secondly, because there seems to be no difference between front and back high vowels with respect to the feature [+ATR] in any language. This is what distinguishing (4) and (5) would imply, given that, in the theory proposed here where R-rules correspond to filters, we would have to suppose two UG filters like *[+high, -back, -ATR] and *[+high, +back, -ATR] to correspond to (4) and (5). Therefore, (4) and (5) must be simplified into the R-rule (6), which corresponds to the well-established UG filter 1.(1)IV)b):

(6) [+high] --> [+ATR]

Now, in Nez Perce, the change from recessive [u] to dominant [o] clearly shows that spreading of morphological [-ATR] creates a disallowed configuration that must be repaired by a clean up rule, i.e., negation in this case. But this means that spreading of morphological

[ATR] occurs when the redundant value [+ATR] is already specified in the feature bundle of /u/. If we suppose that the /i/ in [-ATR] morphemes and words with [-ATR] morphemes results from the fact that the spreading of morphological [-ATR] occurs when the redundant [+ATR] value is unspecified in its feature bundle, we are forced to suppose that in Nez Perce we have the two R-rules (4) and (5) and that these two rules are ordered with respect to the spreading rule: in particular (5) must apply before spreading of morphological [ATR] applies and (4) afterwards. But we have assumed it is impossible to distinguish the two rules (4) and (5). There is only one R-rule that introduces the redundant value in the feature bundle of high vowels: (6). Now, the redundant feature value [+ATR] must be specified in the feature bundle of /u/ before the spreading applies. Therefore, the redundant feature value [+ATR] in the feature bundle of /i/ must also be specified before the spreading applies.

Therefore, we are forced to hypothesize that [i] in [-ATR] morphemes and words with a [-ATR] morpheme is derived by application of the R-rule in (6), followed by spreading of morphological [-ATR] and then delinking of [-ATR].

Observe now that if the R-rules could be ordered, the DSC would force us to apply spreading before applying the R-rule (6) since this would make the derivation from underlying /i/ to surface [i] in [-ATR] morphemes and words shorter. But then the feature [+ATR] in the feature bundle of /u/ would be unspecified when the spreading rule applies. However, this is not correct as we saw above. Now, the DSC

seems to be a very natural and correct condition. Therefore, we have to conclude that R-rules cannot be ordered.

9. SURFACING OF DISALLOWED CONFIGURATIONS OF FEATURES

Let us now turn to a crucial problem which arises in my approach. In a series of cases, clean up rules do not apply to repair configurations of features that violate underlying filters.

If clean up rules always applied to repair configurations of features that violate underlying filters, we would expect that a configuration of features that violates an underlying filter could never surface in any language. This would mean that for each language, the surface segmental inventory would always be identical to the underlying one. But this is absolutely not true. Surface segmental inventories always tend to be richer than underlying ones. This means that configurations of features that violate underlying filters can indeed surface without being repaired by clean up rules

Before discussing this point more fully, I want to show that the possibility of surfacing of configurations of features that violate underlying filters is independent of the stage of the derivation in which the rule that creates them applies, although surfacing is more probable when this rule applies in the later stages of the phonological derivation. Therefore, I will argue against Kiparsky (1984) and (1985)'s proposal that surfacing of configurations of features in violation of underlying filters is only possible in word-sequence phonology ("post-lexical phonology" in Kiparsky's terminology)

First of all, let us consider configurations of features in violation of an underlying filter created by the applications of rules in word-sequence phonology. It is often the case that configurations of features produced by rules in word-sequence phonology can surface unchanged. All of the cases discussed by Kiparsky (1985), by definition, belong to this stage of the derivation. Typically the surfacing of disallowed configurations of features created by rules of word sequence phonology is dependent on the tempo and style of speech. Lass (1984) gives a nice example of the surfacing of disallowed configurations of features in word-sequence phonological rules tied to the tempo and style of speech. Consider the following string:

(1) d:ɪfɪkəlɪzəʔəɪn:əʔsɪrəβærɪʔt°

Apparently, the string in (1) belongs to a language with nasalized vowels, a bilabial fricative β, a velar fricative ɣ and a syllabic fricative like ʔ. But the language of the string in (1) is actually English. (1) is the casual fast speech version in Lass's variety of English of the following sentence in *lento* speech:

(2) ðə dɪfɪkəlɪʔtɪ ʔɪz ðæʔt əɪm nəʔt sɪrə ʔəbæʊʔt ʔɪʔt

That is, "The difficulty is that I'm not sure about it." In Lass's variety of English, the rules of word-sequence phonology produce configurations of features that violate underlying filters. These disallowed configurations of features are clearly not cleaned up and thus may

freely surface.

However, style and tempo of speech are not always determining factors in the surfacing of disallowed configurations of features in word-sequence phonology. This is what we find in the case of vowel nasalization in French, where style and tempo of speech do not play any role. According to Schane (1968) (see also Dell (1973), Levin (1987)), there are no underlying nasal vowels in French, only oral vowels.^[20] Therefore it must be supposed that the UG filter 1.(1)VIII), repeated here as (3), is underlying in French:

(3) * $[+nasal, -consonantal]$

According to Schane, nasal vowels must be derived by an underlying sequence of oral vowel and nasal consonant through the following two ordered rules (I propose an autosegmental representation of these two rules, not Schane's original one):

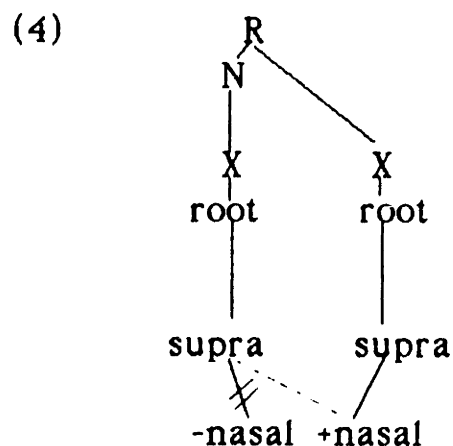

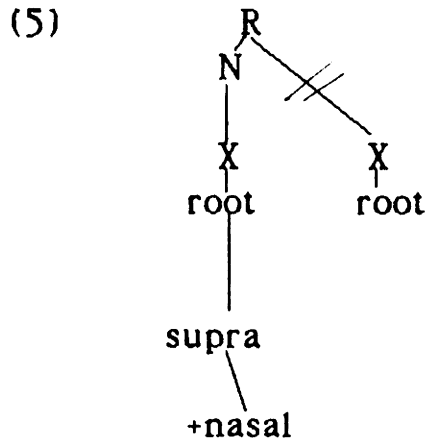

These rules belong to the word-sequence phonology, since they apply after resyllabification across word-boundaries, as can be seen by the alternations displayed by the adjective /bɔ̃n/ 'good,' which appears as [bɔ̃] before words beginning with a consonant, as in 'un bon frere' [œ̃ bɔ̃ frɛr], or pause, as in 'c'est bon' [sɛ bɔ̃], but as [bɔ̃n] 'un bon ami' [œ̃ bɔ̃n ami] before words beginning with a vowel. Observe that vowel nasalization in French is not dependent on style and tempo of speech like the English vowel nasalization seen in (1), which is possible only in casual fast speech.

Let us now consider configurations of features in violation of underlying filters created by the application of rules of word-internal phonology. Even disallowed configurations created by these rules may surface without being repaired by clean up rules.

In their analysis of Malayalam, Mohanan and Mohanan (1984) demonstrate that there are only three underlying nasals, i.e., m, n, ŋ, in Malayalam, but that there are seven nasals, i.e., m, n, n, ŋ, ñ, ŋ', ŋ, at the

end of word-internal phonology (where \underline{n} is a dental nasal, \tilde{n} is a palatal alveolar nasal, and η' is a palatal nasal). These nasals are the output of several rules of word-internal phonology: a rule of nasal assimilation, a rule which changes n into \underline{n} in morpheme initial positions, and a rule of palatalization. Clearly the application of word-internal phonology rules in Malayalam creates configurations of features that are not repaired by clean up rules and surface unchanged.

Now let us consider another example concerning nasals where there is surfacing of disallowed configurations of features created by a word-internal phonology rule. This example comes from Catalan.

Catalan underlyingly has the nasal consonants m , n , η . Observe that nasals with other points of articulation are underlyingly absent in Catalan, and therefore must be blocked by underlying filters. In Catalan, there is a rule that assimilates coronal nasals to the consonants that follow them. This rule produces the velar nasal $[\eta]$ and the post-alveolar nasal $[n,]$. Neither of these segments is present in the underlying inventory of Catalan and therefore must be considered to have configurations of features in violation of underlying filters of this language. $[\eta]$ has a configuration of features in violation of $*[+nasal, +back]$ and $[n,]$ has a configuration in violation of $*[+nasal, -anterior]$. However, neither disallowed configuration is repaired and can freely surface.

Now it is possible to show that nasal assimilation of Catalan is a

cyclical rule and, therefore, clearly a rule of the word-internal phonology of this language. In Catalan, there is a rule that simplifies homorganic nasal + consonant clusters in word final position or before a consonant. We can see the effect of this rule in the following examples:

- (6) a) /kamp + et/ --> [kampét] 'little field'
 b) /kamp+s/ --> [kams] 'fields'
 b) [kámp][és] --> kám és 'the field is'
 c) [kámp][sígi] --> kám sígi 'the field were (s.)'
 d) [kámp] --> kám 'the field'

Let us now consider the following surface sentence:

- (7) beŋ bim pans 'I sell twenty loaves of bread'

The underlying representation of (7) is the following:

- (8) [[[ben]k] [bint] [[pan]s]]

Observe that no ordering between nasal assimilation and cluster simplification can give the surface output in (9):

(9)a)	/benk	bɪnt	pan + s/
Nasal Assimilation	ŋ	n	n
Cluster Simplification	∅	∅	-
	bɛŋ	ˈbɪn	páns
b)	/benk	bɪnt	pan + s/
Cluster Simplification	∅	∅	-
Nasal Assimilation	m	m	-
	*bem	bɪm	páns

The only way to derive the surface form in (9) correctly is to assume that the rules of nasal assimilation and cluster simplification apply cyclically first in word-internal phonology and then in word-sequence phonology. In this way, the surface output in (7) is accounted for straightforwardly:

(10)	/benk	bɪnt	pan + s/
word-internal :			
Nasal Assimilation	ŋ	n	n
Cluster Simplification	∅	∅	-
word-sequence:			
Nasal Assimilation	-	m	-
Cluster Simplification	-	-	-
	bɛŋ	bɪm	páns

We can conclude then that configurations of features in violation of underlying filters produced by word-internal rules may surface unchanged.

Let us now consider the case of another rule of word-internal phonology, the rule of palatalization in Malayalam (cf. Mohanan and Mohanan (1984)). In Malayalam, there are no underlying palatals. The palatals are derived from velars preceded by front vowels by a rule of palatalization. We see the effect of this rule in the following alternations: in (11) there is no palatalization of the dative suffix; in (12), there is palatalization of this suffix because of the preceding front vowel:

	<u>Nominative</u>	<u>Dative</u>	<u>Gloss</u>
(11)	makal	makalkkə	'daughter'
(12)	kuṭṭi	kuṭṭik'kə	'child'

Observe now that there are numerous lexical exceptions to this rule, as is shown in the following contrast:

(13)	wikkan	'stammerer'	mik'k'a	'most'
(14)	ṭikkə	'crowd'	aṭik'kə	'beat-imp'

Observe also that the palatalization rule of Malayalam is sensitive to morphological information: stem final /i/ palatalizes the velar in the dative, causative, or verbalizing suffixes. The same vowel, however,

does not palatalize the velar in the plural suffix, nor does it apply across the stems of a compound. This is shown in (15) a) and b):

- (15) a) kuttikal -> kuttikkal 'children'
b) [[kutti][kali]] -> kuttikali 'childish games'

The fact that there are lexical exceptions to the palatalization rule in Malayalam and that the rule is sensitive to morphological information clearly demonstrates that the rule of palatalization is a rule of word-internal phonology. Now, the fact that no palatal consonants are present in the underlying inventory implies that the configuration of features produced by the application of the rule of palatalization is disallowed by an underlying filter. Nevertheless, this disallowed configuration of features is not repaired by the clean up rules and can surface unchanged.

We have seen that configurations of features disallowed by underlying filters may surface unchanged without being repaired by clean up rules, regardless of whether they are produced by word-sequence phonology or word-internal phonology. I must now account for why clean up rules do not apply in these cases.

In discussing the applications of the clean up rules in B-Chukchi in Section 8, I observed that the application of a clean up rule may produce a configuration of features that violates an underlying filter, provided that this configuration violates an underlying filter at a lower position in the UG filter hierarchy than the filter violated by the

configuration of features that the clean up rule repaired. I then hypothesized that this is possible because the function of the clean up rules is not that of preserving the underlying inventory of segments by eliminating all configurations of features that violate underlying filters, but that of preventing an increase in the complexity of a phonological system by repairing complex configurations of features. The problem is to decide what configurations of features must be considered to be complex. At this point in my research, it is not clear to me what parameters must be used to establish when a configuration is complex. What is clear to me, however, is that configurations of features in violation of underlying filters are not repaired or allowed to surface in a random way, but that there exists a precise pattern: if a given disallowed configuration of features is allowed to surface, other given disallowed configurations of feature must also be allowed to surface. If a given disallowed configuration of features is repaired, other disallowed configurations of features must also be repaired. More precisely, given the UG filter hierarchy, if a configuration of features in violation of a filter at a certain position of the hierarchy is allowed to surface, then a configuration of features in violation of a filter at a lower position in the hierarchy must be allowed to surface. If a configuration of features in violation of a filter at a certain position in the hierarchy is repaired, then a configuration of features at a higher position in the hierarchy must also be repaired. In order to represent this, I will propose that each configuration of features in violation of a UG filter is associated with a certain degree of complexity: configurations of features in violation of filters at higher position in the hierarchy have a higher degree of complexity than configurations of

features at lower positions in the hierarchy. I assume then that each grammar allows a certain degree of complexity X. By this, I mean that configurations of features with a degree of complexity inferior or equivalent to this degree of complexity X are allowed to surface. In contrast, configurations of features with a degree of complexity superior to this degree of complexity X are repaired. I propose the following principle:

- (16) Given a language L, only configurations of features with a degree of complexity superior to the degree of complexity X are repaired in L.

I assume that the degree of complexity X allowed by each grammar may vary among languages. Therefore, it must be established on a language-specific basis. I propose that it is principle (16) which triggers the application of clean up rules. If a certain configuration of features in a language L violates an underlying filter at a high position in the UG filter hierarchy, and has a degree of complexity superior to that allowed in the grammar of L, then principle (16) requires a clean up rule to repair this configuration. For example, in the case of B-Chukchi, I assume that the grammar allows a degree of complexity superior to that of a configuration of features that violates the underlying filter [-high, -low], but inferior to that of configurations of features that violate the underlying filters *[+high, -ATR], *[+low, +ATR]. Therefore, principle (16) requires the repair of a configuration which violates one of the latter filters, and the clean up rule that effects this repair can freely create a configuration that violates the former

underlying filter. In Sect.11, we will see other cases in which clean up rules can create configurations of features disallowed by underlying filters.

Given the preceding proposals, I predict that we should not find a case in which a configuration of features in violation of a filter at a high position in the UG filter hierarchy is allowed to surface, but a configuration of features in violation of a filter at a lower position is repaired. Let us consider a hypothetical case of a language L with a vowel system like that in (17):

- (17)
- | | |
|---|---|
| i | u |
| ε | ɔ |
| a | |

The UG filters in (18) are underlying filters in the vowel system in (17), where (18)a) is in a higher position than (18)b):

- (18) a) * [+high, -ATR]
 b) * [-high, +ATR]

In L, there are one or more rules which create(s) the configurations [+high, -ATR], [-high, +ATR] in violation of (18)a) and b), respectively. According to my proposals, it would be impossible to have the surfacing of the configuration [+high, -ATR] and, at the same time, the repair of the configuration [-high, +ATR]. Given the UG filter hierarchy, the

degree of complexity of the configuration [+high, -ATR] is superior to that of the configuration [-high, +ATR]. Therefore, according to (16), if the former configuration is allowed to surface, then the latter must also be allowed to surface. (16), in conjunction with the hypothesis that the degree of complexity of configurations of feature is determined by the UG filter hierarchy, predicts that we can have only the following situations in L: (i) the configuration [+high, -ATR] is repaired and the configuration [-high, +ATR] is allowed to surface; (ii) both of the configurations [+high, -ATR] and [-high, +ATR] are repaired; (iii) both of the configurations [+high, -ATR] and [-high, +ATR] are allowed to surface. In Sections 10 and 11, we will see several cases which support these predictions. In contrast, in the course of my research, I have not come upon any case similar to the one that I exclude, in which the configuration [+high, -ATR] is allowed to surface, whereas the configuration [-high, +ATR] is repaired.

I hypothesize that the degree of complexity X allowed by a given grammar is sensitive to tempo and style of speech, and propose the following principle:

- (19) The degree of complexity X allowed by a given grammar increases according to tempo and style of speech.

According to (19), the degree of complexity of a configuration of features to which a grammar is sensitive increases depending on the tempo and style of speech: when the tempo is faster and/or the style is more casual, a grammar allows more complexity to surface. Therefore, I

hypothesize that configurations of features with the highest degree of complexity can appear only in fast casual speech.

If I am correct in proposing the UG filter hierarchy and principles (16) and (19), we should find languages in which the following cluster of facts holds: there is a rule that applies at different tempos and creates two configurations of features disallowed by two underlying filters in different hierarchical positions. At a slower tempo only the configuration of features at a lower position in the UG filter hierarchy surfaces, the other is repaired. At a faster tempo, both configurations of features surface. This cluster of facts is predicted to exist if the configurations of features are associated with a degree of complexity according to the hierarchical position of the filter they violate and if principles (16) and (19) are correct. In the slower tempo, only the degree of complexity of the configuration of features in violation of a filter at a lower position is allowed. Therefore, this configuration of features is allowed to surface; the configuration of features in violation of the filter at the higher position must instead be repaired by (16), since it has a degree of complexity superior to that of the other configuration. At a faster tempo, the degree of complexity of the configuration of features in violation of the filter at a higher position in the hierarchy is allowed. Therefore, both this configuration of features and the configuration of features in violation of the filter at the lower position must be allowed to surface. According to my proposal, at a faster tempo we cannot find a situation in which only the configuration of features in violation of the filter at the higher position in the hierarchy is allowed to surface, whereas the configuration of features in

violation of the filter at the lower position is repaired.

Vowel devoicing in Japanese seems to support these predictions. Vowel devoicing in Japanese is a clear example in which we see that the surfacing of disallowed configurations of features is sensitive to the change of tempo (cf. Block (1950), Haraguchi (1977) (1984), Hasegawa (1979)). Underlying vowels are voiced in Japanese. The fact that underlying vowels in Japanese are voiced means that the UG filters which disallow the feature value [-voice] in the feature bundles of vowels are underlying in the phonological system of Japanese. I propose that these UG filters are the following:

- (20) a) *[-voice]/ [____ , -high, +syllabic]
b) *[-voice]/ [____ , +high, +syllabic]

(with the feature [+syllabic], I simply represent the fact that the feature blocked by the filter cannot occur in a feature bundle associated with a syllabic nucleus. Therefore, [+syllabic] in (20) must be considered to be an abbreviatory symbol, and not a distinctive feature (cf. Levin (1985) for arguments against the use of [syllabic] as a distinctive feature)).

I assume that (20)a) is in a higher position in the UG filter hierarchy than (20)b). (The reasons that lead me to hypothesize the two UG filters in (20) will be discussed below.)

However, surface vowels of Japanese may be voiceless if they are preceded by voiceless consonants and followed by another voiceless consonant or a pause (cf. Hasegawa (1979), but not if they are followed

[+voice] is multiply linked to two different root nodes.

I then assume that geminate blockage, effected by either the Uniform Applicability Condition (cf. Schein, and Steriade (1986)) or the Linking Constraint (cf. Hayes (1984)), prevents (22) from applying to the multiply linked configuration produced by (23). Therefore, rule (22) can apply to a vowel only if this vowel is followed by a voiceless consonant or by a pause. This is because only in these cases is the feature value [+voice] of the vowel not linked to another root node.

Now, according to Block (1950), in *lento* speech, high vowels may or may not be devoiced, whereas non-high vowels may not be devoiced. In contrast, in *allegro* speech high vowels are always devoiced in the proper environment, whereas non-high vowels may or may not be devoiced.

Observe that we cannot explain the optional devoicing of vowels according to the tempo of speech by assuming that (22) applies optionally because in this way we would lose the generality of (22). In fact, we would be forced to say that vowel devoicing is not effected by a single rule like (22), but by several rules: a rule that optionally devoices high vowels in *lento* speech; a rule that devoices high vowels in *allegro* speech and a rule that optionally devoices non-high vowels in *allegro* speech. If we do not want a multiplication of quasi-identical rules of vowel devoicing in the phonology of Japanese, we must find another explanation for the optional devoicing of vowels.

I propose that rule (22) is a rule of word-sequence phonology and that it applies obligatorily to all vowels in the proper environment. The application of (22) to vowels creates configurations of features in violation of the UG filters in (20)a) and b).

I assume that the degree of complexity of the configurations of features obtained through this rule is determined by the hierarchical position of filters (20)a) and (20)b). I assume that filter (20)a) is in a higher position in the hierarchy than that of (20)b). The point is that non-high vowels are more sonorous than high vowels. I assume that a more complex configuration of features is created by devoicing the most sonorous vowels than by devoicing the least sonorous vowels. (cf. Haraguchi (1984) on this point). Observe that it is this difference in the complexity of the configurations of features in violation of (20)a) and (20)b) that led me to propose that voicing in vowels must be treated by hypothesizing two different UG filters. Observe that among the languages listed by Maddieson (1984), we find only two languages with voiceless vowels. One is Ik, an eastern Sudanic language, which has the following five voiceless vowels:

(24) ɨ ɥ
 ɛ ɜ
 ɞ

The other is Dafla, a Burmese language, which has only two voiceless vowels:

(25) ɨ ʉ

There is no language which has the following three voiceless vowels:

(26) ɸ ɸ
 ɸ

If we use UG filters to describe the two vowel systems in (24) and (25) and the fact that there is no vowel system that has the voiceless vowels in (26), then we have to assume the two UG filters in (20) with their different hierarchical positions: (20)b) can be violated independently of (20)a), but (20)a) cannot be violated unless (20)b) is also violated. Therefore, the configuration of features produced through (22) in the case of high vowels is less complex than the configuration of features produced through (22) in the case of non-high vowels.

I propose that the degree of complexity allowed in lento speech in Japanese oscillates between being either slightly inferior or equivalent to the degree of complexity of the configuration of features that violates (20)b). Therefore, this configuration is either allowed to surface or is repaired. In contrast, the configuration of features is violation of (20)a), which has a higher degree of complexity than that which violates (20)b), is not allowed to surface and must be repaired. I assume that the repair in both cases is effected by delinking of [-voice]. In this way a voiced vowel is obtained.

In allegro speech, a higher degree of complexity than in lento speech is allowed. Therefore, the configuration of features that violates (20)b) is always allowed to surface without being repaired. However, the degree of complexity allowed in allegro speech is not higher than the degree of complexity of the configuration of features in violation of (20)a). It is equivalent or slightly inferior to it so that this configuration of features is either allowed to surface or is repaired. The repair strategy that is used in this case is also delinking of [-voice].

In this way a straightforward explanation of Japanese vowel devoicing is attained.

At this point, I shall compare the cases of vowel nasalization in French and in English. I assume that the grammar of French allows the degree of complexity of the disallowed configuration of features [-consonantal, +nasal] in lento and careful speech. This configuration of features is allowed to surface in all tempos and styles of speech in French, that is, its appearance is independent of tempo and style of speech. In contrast, in English, the degree of complexity of the configuration [-consonantal, +nasal] is allowed only in fast speech. This configuration is allowed to surface only in fast speech, and cannot appear in other tempos and style of speech.

I will now discuss the case of vowel assimilation in Catalan and Malayalam and the case of palatalization in Malayalam. The conclusions that I will draw are speculative, as the repercussions of my analysis are not entirely clear to me. However, given the importance of the issue, I

believe that these conclusions are worthy of discussion.

I propose that there are cases in which a configuration of features disallowed by an underlying filter may surface without being repaired, independently of its intrinsic degree of complexity. I hypothesize that this occurs when the "syntagmatic configuration" through which this configuration of features is obtained is characterized by being structurally simple (I shall explain the term "syntagmatic configuration" shortly). In this case, the configuration of features must be considered not to have a high degree of complexity, although it violates underlying filters at high positions in the UG hierarchy. In this way, this configuration of feature may be allowed to surface by (16).

First of all, I want to define what I mean with "syntagmatic" configurations created by the application of a phonological rule. I believe that there are two basic aspects of linguistic representations: a paradigmatic aspect and a syntagmatic one. Given the model of non-linear phonology adopted in this thesis, I assume that the paradigmatic components of a non-linear phonological representation are all of the different half-planes that compose it: the syllable structure plane, the stress plane, the segmental melody plane. Furthermore, I assume that feature bundles, i.e., the set of features dominated by the same root node, are paradigmatic components of the segmental melody plane. In this way, I express the traditional idea that phonological segments are paradigmatic components of phonological representations. When all of these paradigmatic components are combined through association with the skeletal slots of the phonological string, we have syntagmatic

configuration. I assume that all context-sensitive phonological rules are adjustments and modifications of these syntagmatic configurations by which features dominated by a root node are linked to (or delinked from) a different root node, or relationships between feature bundles and certain positions in the syllable structure are changed, and so on. Therefore, with syntagmatic configuration I mean the set of the structural relationships between the different paradigmatic components obtained by combining these components in the phonological string.

I hypothesize now that a series of syntagmatic configurations produced by phonological rules are universally marked as highly simple. For example, I hypothesize that this is the case of the syntagmatic configuration produced by nasal assimilation. I represent it in (27):

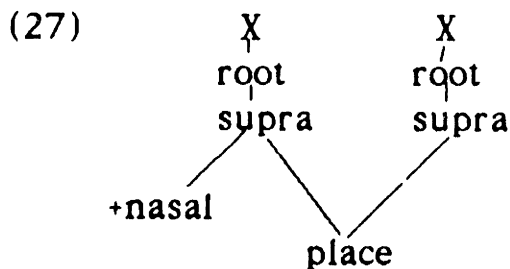

Now I assume that the global degree of complexity of a disallowed configuration of features is given by the sum of the intrinsic degree of complexity of the configuration of features determined by the hierarchical position of the UG filter it violates, plus the degree of complexity of the syntagmatic configuration through which this disallowed configuration is produced. I assume that the degree of complexity of disallowed configurations of features is expressed with

integers, whereas the degree of complexity of syntagmatic configurations must be expressed with negative numbers. The more simple a syntagmatic configuration is, the smaller the value of the negative number is that expresses its degree of complexity. Therefore, a very simple syntagmatic configuration renders simple a disallowed configuration of features with a high degree of complexity. This is very important. In this case, principle (16) will not trigger the application of the clean up rules to repair the disallowed configuration. I hypothesize that this is what happens in the case of nasal assimilation in Catalan and Malayalam (and most other languages of the world). The nasal assimilation rule creates the syntagmatic configuration in (27), which I assume is characterized as being highly simple. If a disallowed configuration of features is produced through this syntagmatic configuration, it must be considered to be simple, i.e., having a low degree of complexity, regardless of the hierarchical position of the filter it violates. Thus for example, velar nasals, which are very complex segments as the hierarchical position of the underlying filter they violate indicates, may surface when they are produced through a configuration like that in (27). In fact, in this case they have a very low degree of complexity. The same holds for palatalization in Malayalam. I assume that the syntagmatic configuration produced by the palatalization rule is very simple. I represent it in (28):

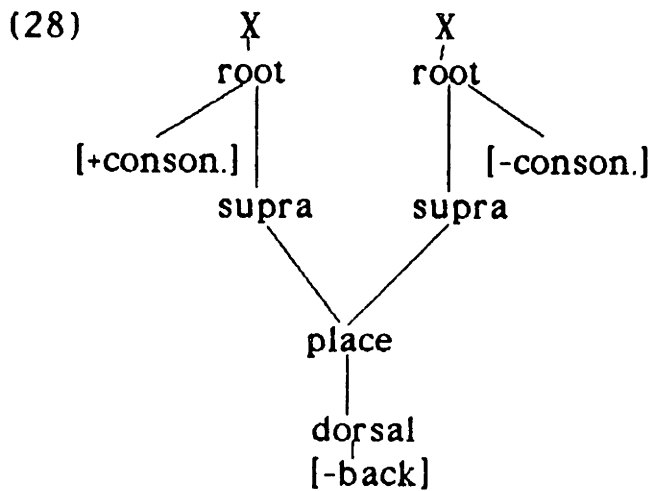

Given the simplicity of the syntagmatic configuration in (28), front dorsal consonants may be produced by it regardless of the filters that these segments violate: the disallowed configurations that these segments will have can surface freely since principle (16) does not trigger the application of the clean up rules to repair them.

My hypothesis is that the syntagmatic configurations in (27) and (28) are universally simple. And in fact, in all the languages in which we find (27) and (28), the disallowed configurations of features that were produced through them can surface without being repaired. In this way, nasal assimilation and palatalization may create segments that are not allowed in the underlying inventory, independently of the complexity of these segments. I hypothesize that there are probably phonetic reasons like ease of articulation behind the simplicity of (27) and (28). However, I will not discuss this point here.

I hypothesize that the syntagmatic configurations produced by phonological rules are always associated with a certain degree of

simplification which renders the disallowed configurations of features produced through them somewhat more simple. In this way, it is possible to explain why disallowed configurations may be allowed to surface by principle (16) if they are the output of the application of a rule, but not if they are introduced by borrowing foreign sounds. Introduction of new sounds by borrowing foreign sounds is quite rare and occurs only in particular situations of bilingualism, or if the lending language has a high prestigious status. I shall not consider this very important issue any further here and I leave it to further research.

10. OKPE AND KWA LANGUAGES

In the analysis of metaphony in southern Italian dialects and harmony in Ogori and Chukchi, I crucially relied on the UG filters in (1):

- (1) c) * $[+low, +ATR]$
- b) * $[+high, -ATR]$
- a) * $[-high, +ATR]$

I proposed that these filters are precisely in the hierarchical order in which they are given in (1). A consequence of the hierarchical order in (1) is that the filter * $[+high, -ATR]$ cannot be violated unless the filter * $[-high, +ATR]$ is also violated. Similarly, the filter * $[+low, +ATR]$ cannot be violated unless the two other filters are violated. Moreover, given the peculiar hierarchical order of the three filters in (1), the configuration of features $[+low, +ATR]$ has a higher degree of complexity than the configuration of features $[+high, -ATR]$. And the configuration of features $[+high, -ATR]$ has a higher degree of complexity than the configuration of features $[-high, +ATR]$.

I now want to discuss the status of UG filters in languages in which they are underlyingly violated. I hypothesize that they always play a role in the phonology of these languages and that what is learned is the knowledge of their underlying violation. Thus for example, in the case of language loss, or aphasia, what happens is that the memory of this knowledge is lost thereby resulting in a restriction of the phonological inventory.

I will first discuss the case of Okpe, a West African language spoken in Nigeria. Okpe displays the following surface vocalic inventory:

(2) i u
 e o
 ε ɔ
 a

However, one can show that the underlying vowel inventory is that in (3) and that the surface vowel inventory in (2) is derived from (3) by rule (4) which merges underlying [+ATR] mid-vowels with underlying [-ATR] high vowels:

(3) i u
 ɪ ʊ
 e o
 ε ɔ
 a

(4) ɪ, ʊ --> e, o

Hoffman (1973) clearly demonstrates this. Okpe has a root-controlled [-ATR] vowel harmony system. Given the seven vowel system in (2), one would expect that [e] and [o] belong to the set of [+ATR] vowels.

However, this is not true. The surface vowels [e] and [o] clearly belong both to the set of [+ATR] vowels and to the set of [-ATR] vowels. This can be seen in the harmonic behavior of affixes combined with monosyllabic verbs containing these vowels. With some of these verbs, the vowels of the prefixes and suffixes must have the [+ATR] form, with others, the vowels of the prefixes and suffixes must have the [-ATR] form. This is shown in (5)a) and b), where the harmonic behavior of the third person singular prefix [o/ɔ-] of the past tense is considered. This prefix appears with its [+ATR] variant [o-] in combination with [+ATR] stems, whereas it appears with its [-ATR] variant [ɔ-] in combination with [-ATR] stems. In (4)a), I present a series of verbs with vowels different from the [+ATR] mid-vowels in order to show the harmonic alternations of the prefix. In (5)b), I present verbs with [+ATR] mid-vowels (the suffix ri/re/ru/ro will be discussed later):

(5)	a)	da	'drink'	ɔ́ááré	'he/she drank'
		dɛ	'buy'	ɔ́dɛ́ré	'he/she bought'
		ti	'pull'	ɔ́tírí	'he/she/it pulled'
		ru	'do'	ɔ́rúrú	'he/she did'
	b)	re	'eat'	ɔ́réré	'he/she ate'
		so	'sing'	ɔ́sóró	'he/she sang'
		se	'fall'	ɔ́sérí	'he/she/it fell'
		so	'steal'	ɔ́sórí	'he/she stole'

If we restrict our attention to the prefix [o/ɔ-], we observe that there are two kinds of [+ATR] mid-vowels in (5)b): [+ATR] mid-vowels that trigger [+ATR] harmony, as expected, and [+ATR] mid-vowels that trigger [-ATR] harmony.

Hoffman (1973) shows that the latter vowels also behave like high vowels. In the case of the infinitive and the continuous tense, monosyllabic verbs with high stem vowels require an additional vowel suffix that is lacking after monosyllabic stems with a non-high stem vowel. Now consider monosyllabic verbs which have a [+ATR] mid-vowel as stem vowel and trigger [-ATR] harmony. Crucially, they behave like monosyllabic verbs with a high stem vowel by taking an additional vowel suffix. We see this in the examples in (6), where, I consider the infinitive formation in Okpe. The infinitive in Okpe is formed from a monosyllabic verb by prefixing [e-] or [ɛ-], the choice between the two depending on whether the stem vowel is [+ATR] or [-ATR]. No suffix is added to non-high vowel verbs, as you can see in (6)a). However, a high tone suffix -ò or -ḥ is added to high vowel verbs (the choice between these two vowels again depends on whether the stem vowel is [+ATR] or [-ATR]. The stem vowel is changed into a glide in front of this high tone suffix. We see this in (6)b):

		<u>Verb</u>		<u>Infinitive</u>
(6)	a)	dá 'drink'		èdá 'to drink'
		dé 'buy'		èdé 'to buy'
		ló 'grind'		èló 'to grind'

	sé	'fall'	èsé	'to fall'
	só	'steal'	èsó	'to steal'
b)	tí	'pull'	ètyó	'to pull'
	rú	'do'	èrwó	'to do, to make'
	ré	'eat'	èryó	'to eat'
	só	'sing'	èswó	'to sing'

In (6)b), the monosyllabic verbs ré and só apparently have non-high vowels. However, they behave like verbs with high vowels by requiring an additional suffix. At the same time, although they apparently have [+ATR] vowel, they trigger [-ATR] harmony].

If we hypothesize that the underlying vowels of the verbs ré and só of (6)b) are the [-ATR] vowels /ɪ/ and /ʊ/, we can account for the behavior of ré and só straightforwardly. Given that these monosyllabic verbs have high vowels, they must receive the additional suffix -o/-ɔ. Given that their vowels are [-ATR], they trigger [-ATR] harmony. Therefore, we must assume that the underlying vowel inventory of Okpe is that in (3) and that there is a rule like (4) which changes underlying high [-ATR] /ɪ/ and /ʊ/ into mid [+ATR] [e] and [o], respectively. Observe that if we assume this, we can immediately account for the different variants of the suffix of the past tense in (5). First of all, we have to assume that there is a rule that changes a high vowel into a back vowel when preceded by a high back vowel. We can

then assume that the underlying form of the suffix is /-ri/. When it is combined with a stem that has an underlying high back vowel, it will become [-ru] if this vowel is [+ATR] and [-rv] if this vowel is [-ATR]; in this last case, it will surface as [-ro] by (4). When it is combined with a stem that has an underlying a non-high back vowel or a non-back vowel, it will become [-ri] if the underlying vowel is [-ATR] and it will surface as [re] by (4). If the underlying stem vowel is [+ATR], the underlying [-ri] will surface unchanged as [-ri].

Let us now turn to rule (4). I hypothesize that (4) is not an arbitrary rule and that it is fully justified in the theoretical approach I am proposing. I propose that (4) is an instance of the clean up rule of negation applied to repair the configuration [+high, -ATR] yielding the derivation in (7):

$$(7) \quad [+high, -ATR] \quad \rightarrow \quad -([+high, -ATR]) \quad \rightarrow \quad [-high, +ATR]$$

The question now is why the configuration [+high, -ATR] should be repaired in Okpe. As a matter of fact, the UG filter *[+high, -ATR] is underlyingly violated in this language, as is shown by the fact that there are high [-ATR] vowels in its underlying inventory.

First of all, I hypothesize that in each language every configuration of features always has the intrinsic degree of complexity determined by the hierarchical position of the UG filter that it violates, regardless of whether this UG filter is underlying or not in this

language.

I assume then that in the normal case the degree of complexity allowed by the grammar is superior to the degree of complexity of the configurations of features allowed by the underlying filters, i.e., the configurations of features or the segments present in the underlying inventory.

However, in order to explain why the configuration [+high, -ATR], which is allowed by the underlying filters of Okpe, is repaired in this language, I propose that the degree of complexity allowed by the grammar may be lowered at a certain point of the phonological derivation. When this happens, underlying configurations of features with a degree of complexity higher than this lowered degree of complexity must be repaired by 9.(16).

I hypothesize that this is what happens in Okpe. At a certain point of the phonological derivation of Okpe, after the application of the harmony rule and the other morphological rules that determines the selection of the suffixes, the degree of complexity allowed by the grammar is lowered in such a way that only the degree of complexity of the configuration [-high, +ATR] is allowed. Therefore, this configuration is allowed to surface. Now, given the hierarchical order in (1), the configuration [+high, -ATR] will have an intrinsic degree of complexity higher than that of the configuration [-high, +ATR]. Therefore, according to principle 9.(16), the configuration [+high, -ATR] must be repaired. I hypothesize that it is repaired by negation. In this

way I account for rule (4).

I hypothesize that the lowering of the degree of complexity allowed by the grammar of a language is one of the possible linguistic changes that can occur. In particular, I hypothesize that it represents a change towards the simplification of the underlying phonological inventory, i.e., towards the stage in which the UG filters that were previously underlyingly violated are reinstated as underlying filters. If this is correct, we would expect that context-free rules like (4) tend to be instances of clean up rules triggered to repair configurations of features with a high degree of complexity, i.e., configurations of features that violate UG filters at high positions in the UG filter hierarchy. This seems to be correct. Configurations of features with a very low degree of complexity, i.e., configurations of features that violate filters at low positions in the UG hierarchy--configurations of features like [-high, -low] of mid vowels, for example--tend not to be eliminated by context-free changes like that in (4).

Support for this hypothesis comes from the historical changes which occurred in a group of African languages under the name of Niger Congo Kwa analyzed by Stewart (1971). In the vocalic system of these languages, we have the [+/- ATR] opposition which characterizes most of the central African languages. If we had a [+/- ATR] opposition for each vowel, we would get the ten vowel vocalic system in (8), where capital /A/ is the [+ATR] counterpart of [-ATR] /a/:

(8)	-ATR		+ATR	
	ɪ	ʊ	i	u
	ɛ	ɔ	e	o
	a		A	

In a vocalic system like the one in (8), all of the UG filters in (1) are violated. Stewart argues that the proto-language from which all of the Niger Congo Kwa languages are derived had precisely the vocalic system in (8).

As Stewart shows, however, only a few of the modern Kwa languages have a vocalic system like that in (8) where the UG filters in (1)a)-c) are violated. Stewart shows that the [+ATR] low /A/, i.e., the violation of (1)c), and the [-ATR] high /ɪ, ʊ/, i.e., the violations of (1)b), are most commonly eliminated. Therefore, from a common ancestor that had to have the ten vowel vocalic system in (8)--as the comparative analysis of the languages of this group requires--we obtain different languages differentiated in the structure of their vocalic systems according to whether configurations of features in violation of (1)b) or in violation of (1)c) or in violation of both are repaired. It is very interesting to see how these configurations of features were repaired.

In some languages, Stewart observes, [+ATR] /A/ is replaced with its [-ATR] counterpart /a/, and in others the [-ATR] /ɪ, ʊ/ are replaced

with their [+ATR] counterparts /i, u/.

According to Stewart, there are also languages in which the low [+ATR] /A/ is replaced by the mid [+ATR] /e/ and/or in which the high [-ATR] /ɪ, ʊ/ are replaced by their mid [-ATR] counterparts /ɛ, ɔ/.

The most interesting fact that Stewart observes is that "quite commonly, [...], the awkward vowels are eliminated by an interesting combination of two changes in tongue position; root-advanced low /A/ is replaced with one or both of its root-unadvanced mid-counterparts /ɛ, ɔ/ , and root -unadvanced high /ɪ, ʊ/ are replaced with their root advanced mid counterparts /e, o/." (Stewart (1971) p.180).

I can account for these phonological changes quite simply. I assume that at a certain point in the history of these languages, a lowering of the degree of complexity allowed by their grammars occurred. In particular, only a degree of complexity equivalent to that of a configuration of features in violation of the UG filter (1)a), i.e., *[-high, +ATR], was allowed. Therefore, configurations of features that underlyingly violated the two UG filters (1)b) and c), which were at higher positions in the UG filter hierarchy, had to be repaired according to principle 9.(16). Thus, the feature configurations of the segments [-ATR] /ɪ, ʊ/ and [+ATR] /A/ became disallowed in the phonological systems of those languages, because of the presence of the configuration of features [+high, -ATR] in the former case and the configuration of features [+low, +ATR] in the latter. These disallowed

configurations of features had to be cleaned up in some way. The different repair strategies were delinking of [ATR], delinking of [high] or [low], or negation. In (9)a)-c), I correlate the different diachronical changes from the proto-vowel system with the different clean up strategies. In (9)a), we have the case in which delinking of [ATR] was applied. Therefore, we obtained [+low, -ATR] from [+low, +ATR], and [+high, +ATR] from [+high, -ATR]. In (9)b), we have the case in which delinking of [high] and [low] was applied. In (9)c), we have the case in which negation was applied. Therefore, we got [-high, +ATR] from [+high, -ATR], i.e., [-ATR] /ɪ, ʊ/ changed into /e, o/; and we got [-low, -ATR] from [+low, +ATR], i.e., /A/ changed into /ɛ/.

- (9) a. A > a (delinking of [+ATR])
 ɪ, ʊ > i, u (delinking of [-ATR])
- b. A > e (delinking of [+low])
 ɪ, ʊ > ɛ, ɔ (delinking of [+high])
- c. A > ɛ (negation)
 ɪ, ʊ > e, ɔ (negation)

In (9)d) I give a series of comparative correspondences of the different results of the original *ɪ, *ʊ in the Kwa Languages (from Stewart (1971) p. 180):

(9) d

	<u>father</u>	<u>under</u>	<u>on</u>	<u>ear</u>
Cama	n- t ^h e	a- t ^h e	a- t ^h o	
Betibe	e- he			o- ho
Anyi-Bawule(Anyi)	si			su
Anyi-Bawule(Bawule)	si		su	
Akan	o- si	a- si	su	(a- s ^u)
Awutu	se	a- in se	e- so	
Chiripon-leter-Amun	si	a-si	su	su

Stewart observes that it is quite common for Kwa languages to have [-ATR] /ɹ, ʋ/, but not [+ATR] /A/, whereas it is quite uncommon for them to have [+ATR] /A/ but not [-ATR] /ɹ, ʋ/.

This observation supports the hierarchical ordering of the UG filters proposed in (11). The hierarchical ordering in (1) indicates that the degree of complexity of a configuration of features that violates (1)a) is inferior to the degree of complexity of a configuration of features that violates (1)b), and the degree of complexity of a configuration of features that violates (1)b) is inferior to the degree of complexity of a configuration of features that violates (1)c). Therefore, we should expect that the degree of complexity of a configuration of features that violates (1)c) is allowed, then the degree of complexity of the configurations of features that violate (1)b) and (1)a) must also be allowed. Therefore, in a given language, if the surfacing of the

configuration [+ATR, +low] is allowed, then the surfacing of the configurations [+high, -ATR], [-high, +ATR] must also be allowed. However, the inverse does not hold: if the degree of complexity of a configuration of features that violates (1)b) is allowed, then the degree of complexity of a configuration of features that violates (1)c) is not necessarily allowed, since the latter degree of complexity is higher than the former.

In other words, if A is allowed to surface in a language, then ɿ and ʊ must also be allowed to surface in that language, but if ɿ and ʊ are allowed to surface, A is not necessarily allowed to surface. This accounts for the facts observed by Stewart. Then, given the degree of complexity of the configuration of [+ATR, +low] of A shown by (1), we can also expect that this configuration should tend to be repaired more often. The rarity of A supports this prediction.

Observe also that the configuration [-high, +ATR] is not repaired in any of the Kwa languages, so that [+ATR] mid-vowels are present in the vowel inventory of all of the Kwa languages. This can be explained by hypothesizing that the degree of complexity of configurations of features in violation of (1)a) is very low, much lower than that of configurations of features in violation of (1)b), and that degree is much lower than the degree of complexity allowed by the grammar in the Kwa languages. In this way, the configuration [-high, +ATR] is never repaired and is always allowed to surface in these languages.

In summary, we have seen how dialectal and diachronic changes may be explained by the hypothesis that a lowering of the degree of complexity allowed by the grammar can occur and by the hypothesis that the degree of complexity of segments is established by the hierarchical ordering of UG filters.

11. ROMANCE LANGUAGES.

It is interesting now to consider the diachronic development of the vowel system which occurred in a completely different group of languages, the Romance languages. This development seems to be very nicely accounted for in my approach based on the interaction among phonological rules, hierarchically ordered UG filters and clean up rules.

The rule in (1) is traditionally assumed to explain the evolution of the vocalic system of classical Latin into the vocalic system of most of the Romance languages.

(1) +high > -high
 -ATR +ATR

Rule (1) changes into /e/, /o/ the supposed [-ATR] high vowels /ɪ/, /ʊ/ which are produced by the interpretation in late Latin of the opposition in quantity as opposition in [ATR]. Now, it is interesting to note that

rule (1) resembles the cases of the negation rule that we used to explain the alternation between [-ATR] mid-vowels and [+ATR] mid-vowels in a metaphonic context in southern Umbro, the neutralization rule of Okpe and the historical changes in the Kwa languages. In this Section, I shall consider this similarity and propose an analysis of the evolution of Latin into the Romance languages.

In Calabrese (1986), I proposed that classical Latin had the vocalic system in (2):

(2) i u
 ε o
 a

In this vocalic system, the three filters in 10.(1) are respected. There are no [+ATR] mid-vowels, [-ATR] high vowels or [+ATR] low vowels.

The peculiar characteristic of classical Latin is that vowels may be associated with two timing slots, independently of the presence of another timing slot in the rime. thus, in the same syllabic context, there is an opposition between vowels associated with one timing slot and vowels associated with two timing slots, i.e. the opposition in quantity of the traditional grammar, as we can see in (3):

(3) X X X
 | |
 v v

We, therefore, have the oppositions between short and long vowels in

(4):

(4)	X	~	X X	(= í ~ ī)
			/ \	
	i		i	
	X	~	X X	(= ě ~ ē)
			/ \	
	ε		ε	
	X	~	X X	(= ā ~ ā)
			/ \	
	a		a	
	X	~	X X	(= ŏ ~ ȏ)
			/ \	
	o		o	
	X	~	X X	(= ů ~ ū)
			/ \	
	u		u	

Let us suppose now that at a certain point in the history of Latin the rules in (5) were introduced:

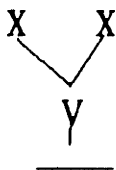
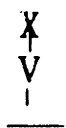
(5) a.	[]	>	[+ATR]	
b.	[]	>	[-ATR] /	

The rules in (5) applied when the feature bundles of the vowels were already fully specified. We can hypothesize that the features assigned by (5) affected the feature bundle of the vocalic segment, delinking the feature [ATR] when it had a different value. Thus we got the four cases in (6) (we consider only the [-back] series):

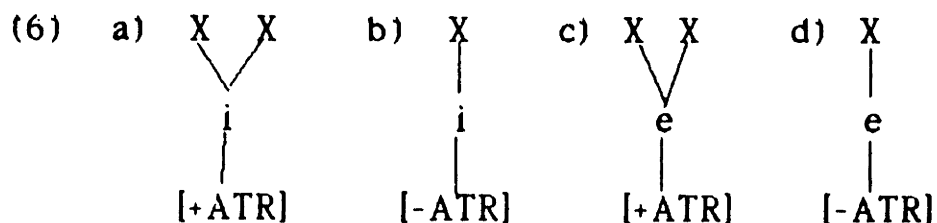

After the feature assigned by (5) affected the feature bundles of the vowels, we obtained the following feature bundles (we consider only the features [high] and [ATR]; the other features are not important):

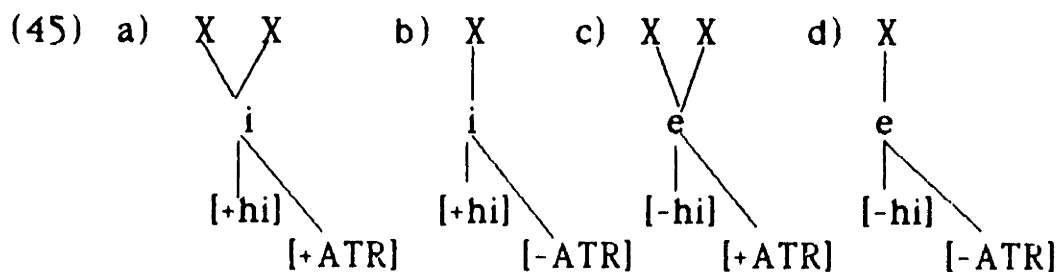

The most interesting question for me to consider is how we got from the classical Latin vocalic system to the Romance vocalic system. I propose that in the variety of Latin from which most of the Romance languages are derived, the maximum degree of complexity allowed by principle 9.(16) corresponds to the degree of complexity of the configuration of features that violates the UG filter 10.(1)a). Therefore in this variety, the degree of complexity of the configurations of features that violate 10.(1)b) and 10.(1)c) is disallowed by 9.(16), and hence those configurations must be repaired. Thus while [+ATR] mid-vowels were allowed to surface, high [-ATR] and low [+ATR] vowels were blocked and had to be cleaned up. The clean-up strategy that was selected for high [-ATR] vowels was negation; that for low [+ATR] vowels was delinking of [+ATR]. Thus, we had the derivations in (8)

and (9):

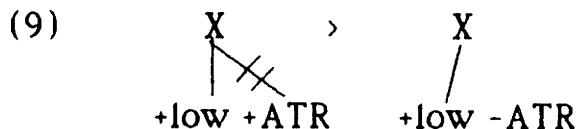
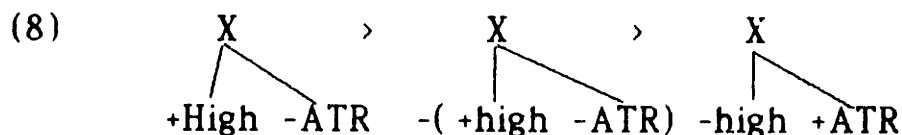

Therefore, the short [-ATR] high vowels /ɪ, u/ produced by rule (5)b) were changed into the [+ATR] mid-vowels /e, o/; and the long [+ATR] low /A/ produced by rule (5)a) was changed into the [-ATR] /a/.

Therefore, I hypothesize that the superficial vocalic system of this variety of Latin at this stage differed from that of classical Latin as indicated by the correspondences in (10):

(10)

i	y	ē	ě	ā	ǎ	ǝ	ō	ū	ū
i	ě	ē	ě	ā	ǎ	ǝ	ō	ǝ	ū

What happened then was that short vowels were lengthened in stressed open syllables and long vowels were shortened in unstressed and closed syllables. In this way the opposition in quantity was lost. I will not discuss this well-known phenomenon here.

When the distinction in quantity was lost, the new quality of the vowels was preserved. Thus, we had the evolution in the vocalic system that we see in (11):

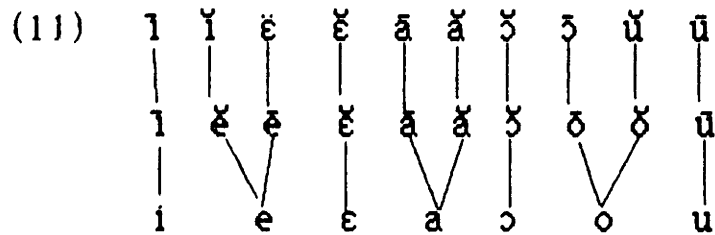

With the loss of the distinction in quantity, the [+ATR] mid-vowels /e, o/ were phonologized, where with phonologization I mean that the UG filter 10.(1)a) was grammaticalized as being underlyingly violated.

The evolution that we show in (11) is the evolution characteristic of several Romance languages, like standard Italian for example. The evolution of the Latin vocalic system into the vocalic system of southern Lucanian and Sardinian, however, is different. In these vocalic systems, we have the following correspondences with the Latin vocalic system:

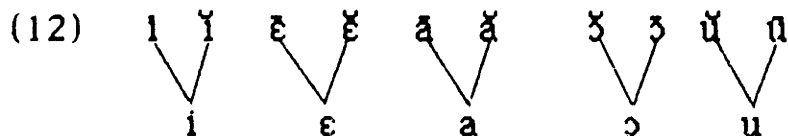

The degree of complexity allowed by principle 9.(16) in the variety of Latin that brought about these languages was inferior to the degree of complexity of the configuration of features [-high, +ATR] which violates 10.(1)a). Therefore, no new segment with respect to the classical Latin system in (2) was allowed to surface. In this case, the clean up rule that applied was delinking of the feature [ATR] in all of

the disallowed configurations produced by rules (5)a) and b).

What this variety of Latin shared with the other varieties of Latin was the loss of opposition in quantity. Thus we have the system shown in the bottom line of (12).

Observe that if the other option of delinking is applied to the case of [-high, +ATR], namely, delinking of [-high], we would get the configuration of features [+high, +ATR]. This is actually what happened in several southern Italian dialects like Sicilian and Southern Salentino, where the Latin vocalic system evolved into a five-vowel system, that of Sardinian and southern Lucanian, but with a different evolution of the long mid-vowels. This is shown in the correspondences in (13):

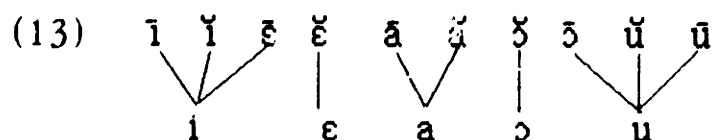

Now let us consider the cases of Romanian and eastern Lucanian, two varieties of Romance languages geographically very distant from each other. The characteristics of these languages is that the front and back vowels of Latin did not develop in the same way, but had different outcomes. The correspondences between the Latin vowels and the vowels of these two languages are as follows:

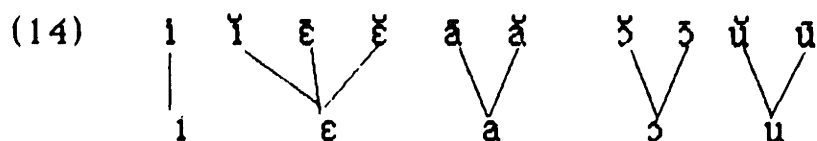

Observe that the historical evolution brought about a five vowel system similar to that of southern Lucanian, Sardinian, Sicilian and southern Salentino. This means that in Romanian and eastern Lucanian, as well as in this group of languages, the degree of complexity of a configuration of feature in violation of the UG filter *[-high, +ATR] was not allowed by 9.(16). Thus we got a standard five vowel system /i, u, ε, o, a/. [22], [23]

The crucial peculiarity which characterizes the evolution of Romanian and eastern Lucanian is the asymmetric development of the Latin short vowels /i/ and /u/. I propose a very straightforward explanation of the change that led to the Romanian and eastern Lucanian vowel systems. In these two languages, the UG filters of the Latin vocalic system were preserved, as they were in the other languages in which we get five vowel systems. The peculiarity of these two languages is that the disallowed configuration [+high, -ATR] is cleaned up in front vowels in a way different from that in which it is cleaned up in back vowels. Thus we had delinking of [+high] in the case of front vowels, and delinking of [-ATR] in the case of back vowels. So given the results of the application of rule (5) in late Latin in (15), where the configurations in b), c), f) and g) are disallowed by the UG filters 10.(1)a) and b), we get the configurations in (16). I consider only the case of the [-low] vowels, since the development of the Latin low vowel is identical in all Romance languages:

- | | | | | | |
|---------|------------------------|----|------------------------|----|------------------------|
| (15) a) | -back
+high
+ATR | b) | -back
+high
-ATR | c) | -back
-high
+ATR |
| d) | -back
-high
-ATR | e) | +back
+high
+ATR | f) | +back
+high
-ATR |
| g) | +back
-high
+ATR | h) | +back
-high
-ATR | | |

- (16) (15)b) > -back (by delinking of [+high])
-high
-ATR
- (15)c) > -back (by delinking of [+ATR])
-high
-ATR
- (15)f) > +back (by delinking of [-ATR])
+high
+ATR
- (15)g) > +back (by delinking of [+ATR])
-high
-ATR

In the case of mid-vowels, we have the same clean up strategy that we had in southern Lucanian and Sardinian, i.e., symmetric delinking of [+ATR] in both front and back vowels. As I said, the peculiarity of the clean up strategy in (16) is the asymmetric treatment of front and back high vowels.

In conclusion, my hypothesis is that a rule was introduced in the phonology of Latin that produced configurations of features disallowed by the UG filters in 10.(1). In the variety of Latin that brought about standard Italian, principle 9.(16) allowed the degree of complexity of configurations of features in violation of 10. (1)a). Therefore, whereas the configuration [-high, +ATR] was allowed to surface, the configurations of features that violated 10.(1)b)-c) were disallowed and had to be repaired. In the other varieties of Latin, principle 9.(16) allowed a degree of complexity inferior to that of configurations of features in violation of 10.(1)a). Therefore, configurations of features in violation of the UG filters in 10.(1) had to be repaired. Different clean up rules operated on the configurations disallowed by 10.(1)a)- c) in order to repair them. These clean up rules produced the different outputs that we have seen.

In this way, a simplification of the treatment of the diachronic changes of the Latin vowel system is achieved, as well as a straightforward account of its different possible outputs which created a situation of dialectal variation.

12. AGAINST STRUCTURE PRESERVATION

Kiparsky (1985, 1986) proposes that for a given language L, there is a principle that prevents lexical (word-internal in the terminology used in this thesis) phonological rules of L from creating segments that do not belong to the underlying inventory of L. He calls this principle Structure Preservation. The function of Structure Preservation is that of preventing the underlying inventory of segments from being modified in word-internal phonology. Kiparsky (1981, 1985) argues that the behavior of transparent neutral segments must be accounted for by using Structure Preservation. Let us consider the case of Finnish discussed in section 3. Kiparsky essentially proposes that if the harmony rule could apply to the feature bundles of the neutral vowels /i/ and /e/, then it would create configurations of features that are not present in the underlying inventory of segments. Therefore, by Structure Preservation, the harmony rule is not applied to neutral vowels /i/ and /e/. The redundant value for [back] is unspecified when the harmony rule applies to these segments. Therefore, since the neutral vowels do not have any value on the tier on which the harmonic value is spread, the harmony rule can apply across them without any problem. In this way the harmony rule does not apply to neutral vowels and , moreover, skips them. This is one of the most interesting and compelling aspects of Structure Preservation.

In the theoretical framework I am proposing, Structure Preservation may be interpreted as a principle which states the

following:

- (1) Word-internal application of phonological rules may not create configurations of features that violate underlying filters.

It is obvious that principle (1) cannot hold in my theoretical framework. If my analysis of Ogori and Chukchi in section 7 and 8 is correct, we have a word-internal application of a phonological rule, i.e., the harmony rule, which creates configurations of features that violate underlying filters. In both cases, contrary to what principle (1) would predict, the harmony rule is not prevented from applying to feature bundles where it creates configurations of features disallowed by underlying filters. Recall that the disallowed configurations of features produced in this way are then repaired by clean up rules. Therefore, we have to conclude that contrary to what principle (1) would predict, the application of word-internal phonological rules may actually create configurations of features disallowed by underlying filters.

However, there are situations in which configurations of features that violate underlying filters cannot be created by the application of word-internal phonological rules, as is the case of the neutral transparent vowels. In Sect. 6, I proposed that the behavior of neutral transparent vowels must be accounted for by principle 6.(1). (6).1 states that phonological rules are prevented from applying to a feature bundle B if they fill in a feature unspecified in B with a value that is disallowed by an underlying filter in B. I argued then that this is what

happens in the case of the neutral transparent vowels of Finnish. The redundant feature [-back] is unspecified when the harmony rule applies. The harmony rule assigns the feature [+back]. If the rule applied to the feature bundle of /i/ and /e/, it would create the disallowed configuration [+back, round]/ [-low, ____]. Therefore, by 6.(1), the rule cannot be applied to these feature bundles. Thus (1) is not needed to account for the behavior of neutral transparent segments. Given that (1) otherwise makes incorrect predictions, it can simply be abandoned.

At this point, one could propose that Structure Preservation is not a principle that blocks the application of phonological rules in word-internal phonology, but instead a principle that ensures that configurations of features that are not present in the underlying inventory of segments (that is configurations of features that violate underlying filters) do not appear at the end of word-internal phonology. This principle is formulated in (2):

- (2) In a language S, at the end of the word-internal phonology of S, there cannot be any configurations of features that violate underlying filters of S.

The fact that there cannot be any configurations of features that violate underlying filters of S would be obtained by assuming that principle (2) can trigger the application of clean up rules that repair configurations of features disallowed by underlying filters, by changing them into allowed ones. This is absolutely incorrect. In Sect. 9, we

have seen that the application of the clean up rules is ruled by principle 9.(16). Now, according to principle 9.(16), the function of the clean up rules is that of repairing complex configurations of features, where their degree of complexity is determined by the hierarchical position of the UG filter they violate plus the degree of complexity of the syntagmatic configurations through which they are obtained.

Principle 9.(16) allows situations that principle (2) would not allow. Given that these situations actually occur, we have support for principle 9.(16) against principle (2). First of all, at the end of word-internal phonology, we can find configurations of features disallowed by underlying filters if they are obtained through syntagmatic configurations that are marked as highly simple. In this case, in fact, the degree of complexity of the configurations of features is simple enough to be allowed to surface by principle 9.(16) without being repaired by the clean up rules. In Sect. 9, we saw that this was the case of the velar nasals created by nasal assimilation in Catalan and Malayalam, and the palatal consonants created by palatalization in Malayalam. These cases would be excluded by principle (2) since principle (2) would require in all of them that the configuration of features disallowed by the underlying filters be repaired by the clean up rules. The fact that this does not occur indicates that principle (2) is incorrect.

Secondly, observe that according to principle 9.(16), clean up rules need not be structure-preserving and, in particular, they need not be structure-preserving in word-internal phonology. In word-internal

phonology, clean-up rules may create configurations of features that violate underlying filters by repairing complex configurations of features. The crucial point for principle 9.(16) is that the disallowed configurations of features that the clean up rules create must be less complex than the configurations of features they repair. Principle (2) would prohibit such behavior of the clean up rules in word-internal phonology: if the function of the clean up rules is that of preserving the underlying inventory of segments, they obviously cannot create new segments themselves.

I will now consider three cases which clearly show non-structure-preserving applications of the clean up rules. I will first consider the vowel harmony system of B-Chukchi which was discussed in Section 8. Vowel harmony in B-Chukchi clearly belongs to word-internal phonology: it governs the combination of morphemes into words and it has the word as its domain. If my analysis of the vowel harmony system of B-Chukchi is correct, we must assume that this language has the underlying three vowel system /i, u, a/ where all of the UG filters in 1.(1) are underlying filters. Now the clean up rules that apply to repair the disallowed configurations [+high, -ATR], [+low, +ATR] created through the complex vowel harmony rules of this language create configurations of features that are disallowed by underlying filters(see Sect. 8 for more details). They create the configurations [-high, -low] in the case of the underlying vowels [i] and [u], and the configurations [-high, -low], [-high, +ATR] in the case of the vowel [a]. We can see this in (3). In (3)a), I present the feature bundles with the disallowed configuration [+high, -ATR] in (i) and (ii), and the disallowed

configuration [+low, +ATR] in (iii):

(3)a (i)	-high	(ii)	+high	(iii)	-high
	-low		-low		+low
	-ATR		-ATR		+ATR
	-back		+back		+back
	-round		+round		-round

The disallowed configuration in (3)a) are repaired by the delinking of [+high] in the case of (i) and (ii), and by the delinking of [+low] in (iii). (Recall that in the last case delinking of [+back] also applies.) Thus we get the feature bundles in (3)b):

(3)b (i)	-high	(ii)	-high	(iii)	-high
	-low		-low		-low
	-ATR		-ATR		+ATR
	-back		+back		-back
	-round		+round		-round

(3)B) (i) and (ii) represent the vowels [ɛ] and [ɔ], respectively; (iii) represents the vowel [e]. In the feature bundles in [ɛ] and [ɔ], we have the configuration [-high, -low] disallowed by the underlying filter *[-high, -low]; and in the feature bundle of [e], we have the configurations [-high, -low], [-high, +ATR] disallowed by the underlying filters: *[-high, -low], [-high, +ATR]. The crucial point is that the position of these filters in the UG hierarchy is lower than the position of

the filters *[+high, -ATR], *[+low, +ATR]. Therefore, the degree of complexity of the configurations that violate the former filters is lower than the degree of complexity of the configurations that violate the latter filters. I assume that the maximal degree of complexity allowed by principle 9.(16) in the word-internal phonology of B-Chukchi is superior to that of the configurations that violate the former filters, but inferior to that of the configurations that violate the latter filters. Thus, the degree of complexity of the configurations in violation of the latter filters is disallowed by 9.(16) and therefore these configurations must be repaired. The repairing then creates the configuration in (3)b) whose degree of complexity is allowed in B-Chukchi by 9.(16). In conclusion, we can say that the application of the clean up rules in B-Chukchi is not aimed at eliminating configurations of features in violation of underlying filters, as principle (2) would predict, but simply at preventing an increase in the phonological complexity of the system.

Let us now consider metaphony in the central Salentino dialect of Campi Salentina discussed in Sect. 5.1. In this dialect, metaphony clearly belongs to the word-internal phonology. In fact, not all of the high vowels in this dialect trigger metaphony. This can be seen in the following verbal paradigms in (4):

- | | | | | | | | |
|-----|----|------------|------------|----|-----|--------|------------|
| (4) | a) | sta séntu | 'I feel' | b) | sta | kkóʝ | 'I pick' |
| | | sta siénti | 'you feel' | | sta | kkuéʝi | 'you pick' |
| | | sta sénte | 'he feels' | | sta | kkóʝe | 'he picks' |

Observe that in (4)a) and b), the high vowel e of the first person

singular does not trigger the metaphony rule. However, the -u of the masculine singular of the adjectives does trigger metaphony, as we can see in (5):

	<u>masc.s.</u>	<u>fem.s.</u>	<u>masc.p.</u>	<u>fem.p.</u>	
(5)	liéntu	lénta	liénti	lénte	'slow'
	buénu	bóna	buéni	bóne	'good'

Therefore, we have to assume that the metaphony rule in the dialect of Campi Salentina must contain morphological information that constrains the class of its possible triggers, and, in particular, excludes the u of the first person singular as a possible trigger. Observe then that there are also lexical exceptions to the metaphony rule in this dialect. I give some exceptions to metaphony in (6)

(6)	méʃʃu	'master'	vs.	nuéʃʃu/nóʃʃa	'our(masc.s./fem.s.)
	bédðu	'beautiful'	vs.	pédðe/piédði	'skin(sing/plur)'
	óssu	'bone'	vs.	ruéssu/róssa	'big(masc.s./fem.s.)

The lexical exceptionality and sensitivity to morphological information show that metaphony in the dialect of Campi Salentina must belong to the word-internal phonology.

Observe now that the distribution of the diphthongs ɛ and uɛ is predictable in this dialect: they occur only in a metaphonic environment. If my analysis of this dialect proposed in Sect.5.1 is

correct, [iɛ] and [uɛ] are always derived by fission, which repairs the complex configuration [+high, -ATR] created by the metaphony rule. [iɛ] and [uɛ] thus do not belong to the underlying inventory. Therefore, in this case as well in the preceding case, the clean up rules have created segments which are not in the underlying inventory, and so the clean up rules are not structure-preserving. As in the preceding case, the crucial point is that the complex configuration [+high, -ATR] is repaired by changing it into a less complex configuration, in this case a short diphthong that contains the two configurations [+high, +ATR], [-high, -ATR] allowed by the underlying filters of this dialect.

Let us now consider a height harmony rule found in Campidanese, a Sardinian dialect spoken in southern Sardinia. My analysis of Campidanese is based upon a very interesting article by Loi Corvetto (1975). In this article, Loi Corvetto describes and analyzes the variety of Italian spoken by speakers of Campidanese and other dialects of Sardinia. She shows that the same height harmony rule that holds in these Sardinian dialects also holds in the different varieties of Italian spoken by the speakers of these dialects, with certain peculiar dialectal variations. Here I am more interested in the phenomena that we find in Campidanese than in the variety of Italian spoken by the speakers of this dialect. Campidanese has the five-vowel system in (7):

(7) i u
 ɛ ɔ
 a

All of the UG filters in 1.(1) are underlying filters of the vowel system in (7), except 1.(1)l). Those of interest to us here are shown in (8) in their peculiar hierarchical order (where d) is the lowest position in the hierarchy):

- (8) a) * [+high, -ATR]
- b) * [+low, +round]
- c) * [-high, +ATR]
- d) * [+low, -back]

Given the filters in (8), we have to suppose the R-rules in (9):

- (9) a) [+high] --> [+ATR]
- b) [+low] --> [-round]
- c) [-high] --> [-ATR]
- d) [+low] --> [+back]

Campidanese has a height harmony rule --similar, in part, to metaphony-- by which the quality of stressed mid-vowels is modified according to the height of the final vowel: if the final vowel is high, the stressed mid-vowel is changed into a [+ATR] mid-vowel; if the final vowel is low, the stressed mid-vowel is changed into a low vowel; and if the final vowel is mid, the stressed mid-vowel is left unchanged.

Unfortunately, the example that Loi Corvetto gives to illustrate the range of modifications in height of the stressed mid-vowels belongs

to the variety of Italian spoken by the speakers of Campidanese, not to the dialect. I assume that the same range of modifications holds for the dialect. Loi Corvetto's example is that in (10). In (11) I give the vowel polygon that she uses to describe the difference in height of the stressed mid-vowels (I give a different interpretation of Loi Corvetto's phonetic transcription):

(10) $sij\eta\text{ɔ}\epsilon^{[24]}/sij\eta\text{ɔ}\text{ra}/sij\eta\text{ɔ}\text{r}$ 'mister (mas.s./fem.s./mas.pl.)'

(11) a)

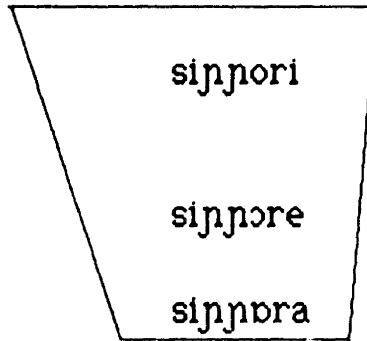

I give the following interpretation to the vowel polygon in (11)a):

(11) a)

sij\eta\text{ɔ}\text{ri}	+ATR	-low
	-ATR	
sij\eta\text{ɔ}\text{ra}	-ATR	+low

I hypothesize that the rule responsible for the alternations in (8) is a rule that spreads the height features of the final vowel onto a stressed mid-vowel. I hypothesize here that the features [high] and

[low] are dominated by another node under the dorsal node, the node "height". This is the node that is spread by the rule of height harmony in Campidanese: I represent the rule of height harmony in (12):

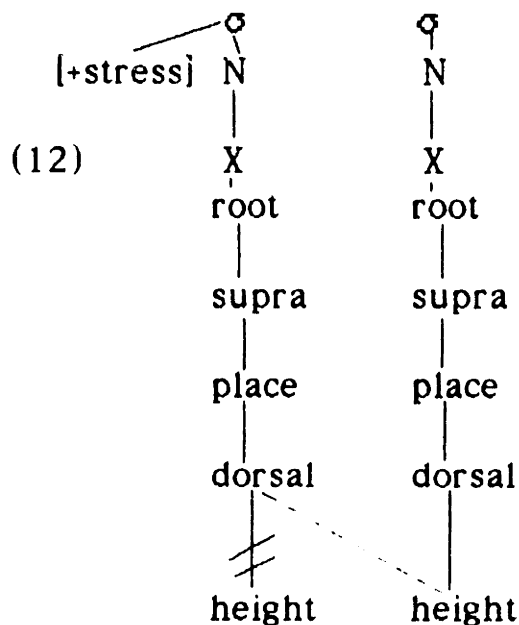

I assume that (12) applies when the R-rules have already applied. In this way, the feature value [-ATR] is present in the feature bundle of the mid-vowels when (12) applies. Thus, if the trigger of (12) is a high vowel, we will obtain the disallowed configuration [+high, -ATR] in target of the rule. The maximal degree of complexity allowed by 9.(16) in the Campidanese word-internal phonology is inferior to that of the configuration that violates (8)a), but superior to that of the configuration that violates (8)b). Therefore, whereas configurations in violation of (8)a) must be repaired, configurations in violation of (8)b) -d) may be allowed. Configurations of features in violation of (8)b) and d) are created by (12) as we see in the following alternations (Loi

Corvetto's examples are in the variety of Italian spoken by Campidanese speakers):

- | | <u>masc. s.</u> | <u>fem. s.</u> | <u>masc. pl.</u> | |
|---------|-----------------|----------------|------------------|-------------------------------------|
| (13) a) | rosso | rossa | rossi | 'red' |
| b) | letto | lætta | letti | 'bed(sing.)' 'red(fem.)' 'bed(pl.)' |

Let us consider the complex configuration [+high, -ATR], which must be repaired according to 9.(16), as I have said. It is repaired by negation and we thus obtain the clean up in (14):

$$(14) \text{ [+high, -ATR] } \rightarrow \text{ -([+high, -ATR]) } \rightarrow \text{ [-high, +ATR]}$$

In (14), the configuration [-high, +ATR] is obtained. This configuration is disallowed by the underlying filter (8)c). But it is allowed to surface by 9.(16), given its low degree of complexity. In this way, underlying /ɛ/ and /ɔ/ are changed to [e] and [o] when the final vowel is a high vowel.

Observe now that [e] and [o] do not belong to the underlying inventory of vowels. Therefore, the application of the clean up rules in Campidanese is not structure preserving and freely produces configurations in violation of underlying filters, provided that they have a lower degree of complexity than that maximally allowed in that language by 9.(16).

Observe now that rule (12) must be considered to belong to the word-internal phonology of Campidanese. Some final high vowels, in fact, do not trigger rule (12). In particular, rule (12) is not triggered by the high vowel i of the suffix of the masculine plural -us, or by the high vowel e of certain suffixes. Thus we have alternations like those in (11)a) in the case of the class of nouns with plural in -us in (11)b) in the case of the verbal conjugation:

	<u>Sing.</u>	<u>Plural</u>	
(11) a)	témp-us	témp-us	'time'
	córp-us	córp-us	'body'
	<u>2nd pers.sing</u>	<u>3rd pers.sing</u>	
b)	ben-i	ben-i	'come'

Therefore rule (12) must be constrained in such a way that it may be triggered by vowels in certain suffixes, but not in others. Thus it must be sensitive to morphological information. But this is a typical property of rules of word-internal phonology. Therefore, we must conclude that rule (12) is a rule of word-internal phonology. But then the negation rule that repairs the complex configuration [+high, -ATR] created by (12) must also apply in word-internal phonology. We thus have another instance of a clean up rule that applies in word-internal phonology and creates a configuration of features disallowed by underlying filters, provided that it is not complex.

We can therefore conclude that the application of the clean up rules is not structure-preserving and that principle (2) is incorrect.

The arguments and the facts discussed in the preceding paragraphs allow us to also exclude another possible interpretation of Structure Preservation. One could in fact propose that underlying filters do not play any role in word-internal phonology, and that only the UG filters that are not violated at the end of word-internal phonology have phonological importance. If this is correct, we should expect that there is no need for clean up rules in word-internal phonology. But this is absolutely not correct. We have seen several word-internal applications of clean up rules, and in all of these cases the clean up rules are triggered by underlying filters. This clearly means that underlying filters actually do play an important phonological role, and that we need them if we wish to explain several phonological phenomena.

12. TWO VOWEL SYSTEMS: THE CASE OF KABARDIAN

According to the set of UG filters for vowel systems proposed in 1.(1), the smallest vowel system should have the three vowels /i, u, a/. This is not correct, as a vowel system smaller than this is possible. We find it in the western Caucasian languages. In this Section, I will discuss the vowel system of Kabardian, one of these western Caucasian languages (cf. Trubetzkoy (1969), Allen (1956), Kuipers (1960), Halle (1970), Anderson (1978), Comrie (1981)). I will add another UG filter to the set of UG filters in 1.(1). This new UG filter will allow me to describe the vowel system of these languages. I will then attempt to account for the rarity of this vowel system among the languages of the world.

To begin, I shall give a brief description of Kabardian segmental inventory, relying on Halle (1970)'s summary of Kuipers (1960). Kabardian, like many other Caucasian languages, exhibits a very rich consonantal system. The obstruent system of this language is shown in table (1), where I reproduce a table analogous to one of Halle (1970)'s tables, in a slightly modified form.

Following Halle (1970), I assume that the palato-alveolar fricatives are [+round], since Kuipers describes them as being "characterized by a slight, wide rounding of the lips" (Kuipers (1960) p. 20).

In addition to the obstruents in (1), Kabardian has the following

(1) Kabardian obstruents:

	stiff				const. glot.		lat.	ant.	distr.	high	back	low	round	[ATR]	
	+	-		+											
labial	p	f	b	v	p'	f'							-		labial
dental	t/c	s	d/ʒ	z	t'/c'	s'	+								coronal
alveopalatal		ʃ		ʒ			-								
pal.-alveolar		ʂ		ʐ			-						+		
palatal		tʃ		ʎ	tʃ'		+								dorsal
pal.-velar (palatal)	k	x	g		k'				+	-					
pal.-velar (labial)	k'	x'	g'		k''				+	+			+		
uvular (plain)	q	ʁ		ʁ'	q'				-	+					
uvular (labial)	q'	ʁ'		ʁ''	q''				-	+			+		
pharyngeal		ħ										+			
	-	+	-	+	-	+									
	cont.		cont.		cont.										

other consonants: the liquid [r], the nasals [m, n] and the glides [ʔ,ʔ°, h, ɣ, y, w), where ɣ is a pharyngeal comparable to the Arabic ʕ. (Kuipers (1960), p. 21).

Let us now consider the vowels of Kabardian. Phonetically, Kabardian vowels can be short or long. Confining our attention to short vowels, we note that short vowels can cover nearly the whole of the traditional vowel triangle. Their distribution is severely limited by the surrounding consonants. However, only two possible qualities may occur in a given consonantal environment. "The two possible qualities found in [a] given environment differ from one another only in relative height, with other features of their articulation being determined in a clear assimilatory fashion by the surrounding consonants".(Anderson 1978,p.78)

Kuipers (1960) describes the distribution of the short vowels in great detail:

Front vowels, a higher one and a lower one, appear after laterals, palatalized palato-velars and glide [y], i.e., after dorsal consonants that are [+high, -back].

Back unrounded vowels, a higher one and a lower one, appear after plain uvulars, i.e., after dorsal consonants that are [-high, +back, -round]. The same vowels can appear after laryngeals and pharyngeals.

Rounded back vowels, a higher one and a lower one, appear after labialized palato-velars, uvulars and laryngeals, i.e., after consonants that are [+back, +low, +round].

Central vowels, a higher one and a lower one, appear after other consonants, i.e., labials and coronals.

Further modifications are due to the following consonant. If this consonant is rounded, then the vowels are rounded. When this is the case, we can obtain front rounded vowels if a front consonant precedes the vowel.

From a phonological point of view, we are then forced to say that in Kabardian there are only two contrasting short vocalic elements, distinct only in relative height: the higher one is usually represented with ə and the lower one is usually represented with a . Colarusso (1975) (quoted by Anderson (1978)) characterizes these two vocalic elements in the following way: "the sequence $C_1\text{ə}C_2$ means 'go from 1 to 2 letting your tongue follow the shortest path that permits an interval of sonorant voicing'. $C_1\text{a}C_2$ means 'go from 1 to 2, permitting an interval of sonorant voicing, but at the same time imposing upon this trajectory an articulatory gesture which pulls the tongue body down and back'".

Let us consider the long vowels of Kabardian now. Phonetically,

there are five long vowels in this language: i:, e:, u:, o:, a:. Kuipers (1960) demonstrates that the long vowels i:, e:, u:, o: must be analyzed phonologically as sequences of a short vowel plus a semivowel, as /əy, ay, əw, aw/. He points out that when these sequences belong to the same syllable (i.e., when they are not followed by a vowel) they are changed into [i:, e:, u:, o:], respectively. Kuipers then demonstrates that the long vowel a: is also phonologically the result of a sequence /ah/ (alternating with /ha/ by a rule which also relates /ay/ and /ya/, etc.).

Therefore from the phonological point of view, we need to posit at most two vocalic elements in Kabardian, a low one and a non-low one. I propose the following filter to account for the Kabardian vowel system (recall that the context [+syllabic, ____] must be considered to represent the fact that the feature in the filter is in a feature bundle associated with a syllabic nucleus) :

(2) * [+high]/[+syllabic, ____]

(2) states that a feature bundle associated with a syllabic nucleus, i.e., the feature bundle of a vowel, cannot contain the feature [+high]. I propose that (2) has a hierarchical position lower than that of the UG filter 2.(6).1. Therefore, if (2) is not underlyingly violated in a phonological system, then none of the filters in 2.(6) are underlyingly violated in that system. To see the consequences of the adoption of (2), let us consider the only vowels that are allowed if all of the UG filters in 2.(6) are not underlyingly violated: /a, i, u/. I give their feature

bundles in the form of matrices in (3):

(3)	a)	i	b)	u	c)	a
		+high		+high		-high
		-low		-low		+low
		-back		+back		+back
		-round		+round		-round
		+ATR		+ATR		-ATR

(2) disallows the feature bundles of the high vowels /i/ and /u/ in (3). Therefore, in a vowel system in which (2) is not underlyingly violated, i.e. in which it is an underlying filter, only the feature bundle of the vowel /a/ is allowed.

I propose that a syllabic nucleus does not need to be associated with a feature bundle in the phonological component. I assume then that in the phonetic execution, such a syllabic nucleus is interpreted as having the articulatory configuration of the vowel schwa.^[25]

Let us now turn back to Kabardian. I propose that the vowel system of Kabardian is composed of the vowel /a/ and the vowel /Ø/ where with vowel /Ø/ I mean a syllabic nucleus not associated with a feature bundle. I represent this vowel system in (4):

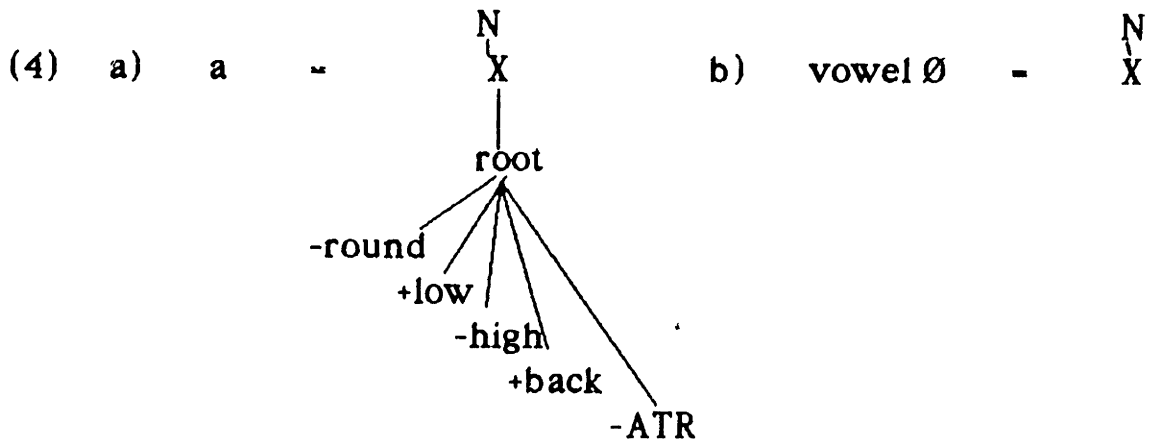

Observe that (4)a) and b) cannot be eliminated in phonological representations in Kabardian, as proposed by Anderson (1978), who develops a similar proposal made by Kuipers (1960). First of all, the position of the syllabic nucleus cannot be predicted in Kabardian. The onset of a syllable in this language may be composed of either one or more consonants, as we see in (5) (from Kuipers (1960):

- | | | | | | | |
|-----|-----|----------------------|---------|--------------|-------|--------------|
| (5) | pə | 'choking with anger' | psə | 'water' | | |
| | fa | 'rotting' | fta | 'sex-organs' | | |
| | žə | 'old' | bžə | 'yoke' | | |
| | t'ə | 'ram' | k'əa | 'going' | t'k'ə | 'melt' |
| | šə | 'horse' | šk'əəmp | 'bad egg' | | |
| | ɬə | 'blood' | ɬx'ə | 'millet' | ɬx'ə | 'give birth' |
| | k'ə | 'twig' | psk'ə | 'washing' | | |
| | ʃə | 'fishing net' | stʃə | 'scratching' | | |

Now consider words like those in (6):

- (6) a) pəʔ 'hanging' pʔə 'getting hot'
 b) ʂət 'being' ʂtə 'freezing'

There is no rule that can predict the position of the syllabic nucleus in the words in (6). Therefore, we must assume that the position of the syllabic nucleus is specified in underlying representations in the words in (6). Thus, the two words in (6)a) must be underlyingly represented as in (6)c):

- (6) c) $\begin{array}{c} \text{N} \\ | \\ \text{X} \text{X} \text{X} \\ | \quad | \\ \text{p} \quad \text{ʔ} \end{array}$ $\begin{array}{c} \text{N} \\ | \\ \text{X} \text{X} \text{X} \\ | \quad | \\ \text{p} \quad \text{ʔ} \end{array}$

I do not agree with Anderson (1978), who following Kuipers (1960), proposes that the consonantal clusters of Kabardian should not be treated as combinations of different consonants, but as "complex segments," where with complex segments he means a cluster of segments linked to the same autosegment. Anderson bases his proposal on the fact that the members of a consonantal cluster always share the same laryngeal features, a fact that can be accounted for by hypothesizing that they are linked to the same laryngeal node. Following Kuipers in this, he assumes that consonantal clusters, being complex segments, behave as consonantal units. If this is correct, the position of the syllabic nucleus in (5) becomes predictable: it always occurs after a single consonantal unit. Therefore the words in (5)a) could be underlyingly represented as in (7) where I represent the

complex segment by supersigning the symbol on the segments that compose it:

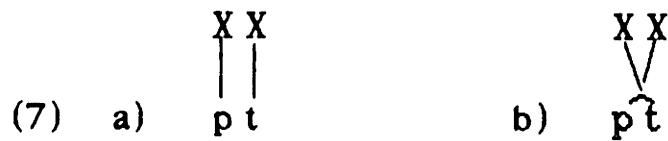

The rule that inserts the syllabic nucleus would be that in (8):

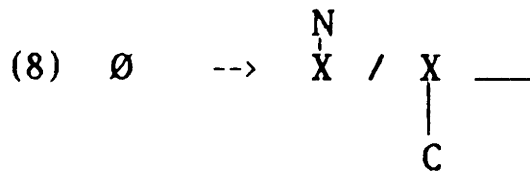

Anderson's analysis can hold only if complex segments like that in a) are underlying, and not the result of a rule that spreads laryngeal features of a consonant to an adjacent consonant, since then the contrast between (7)a) and b) would be lost. But if the consonantal clusters of Kabardian are underlyingly complex segments, then the already very complex consonantal inventory of this language would be increased in a gigantic way, since there are not many restrictions on combinations among consonants in clusters, as can be seen in (5). This would lead to an incredible complication of the Kabardian grammar which clearly cannot be counterbalanced by the predictability of the position of the syllabic nucleus.

Observe then that consonantal clusters in Kabardian can also be obtained through a morphological process of prefixation. Kabardian indicates the 1st and 2nd person sing. and pl. with the following prefixes

t'ə-zə 'old man' (--> təz by a rule that deletes morph.-
final ə)

If syllabic nuclei are not present in underlying representations, then there is no difference in underlying representations between the prefixation of the 1st person sing. in (10)a) and the morpheme concatenation in (11)a). They should both be underlyingly represented as in (12):

$$(12) \quad \begin{array}{c} X \\ | \\ s \end{array} + \begin{array}{c} X \\ | \\ t \end{array} (= (10)a)) \quad \begin{array}{c} X \\ | \\ \check{s} \end{array} + \begin{array}{c} X \\ | \\ d \end{array} (= (11)a))$$

Why then does the syllabic nucleus appear after the second consonant in (12)a), but after the first in (12)b). Obviously, we cannot say that the sequence st in (12)a) is an underlying "complex segment." Anderson (1978) would explain the difference between (12)a) and b) by proposing that the s of (12b) is associated with a diacritic feature [+syllabic] which triggers the formation of a syllabic head, whereas the s of (12)a) is not associated with such a feature. But this move would not only introduce more and more distinctive consonants into the already huge underlying inventory of segments, but would also be essentially equivalent to the proposal that the syllabic nucleus is present in underlying representations.^[26] Therefore, I propose that the correct underlying representations for (12)a) and b) are those in (13)a) and b):

$$(13) \quad \begin{array}{c} X \\ | \\ s \end{array} + \begin{array}{c} N \\ | \\ X \\ | \\ t \end{array} (= (10)a)) \quad \begin{array}{c} N \\ | \\ X \\ | \\ \check{s} \end{array} + \begin{array}{c} N \\ | \\ X \\ | \\ d \end{array} (= (11)a))$$

At this point we can explain the fact that members of consonantal clusters share the same laryngeal features by assuming a phonological rule of spreading of laryngeal features in (14). This rule is independently needed to account for the assimilation in laryngeal features of the prefixes in (9).

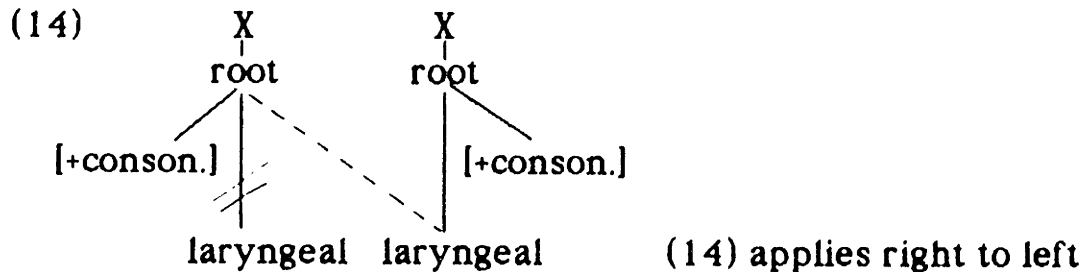

Anderson (1978), following Kuipers (1960), also argues that vowel /a/ could be eliminated from underlying representations. He proposes that the feature [+low] is not a feature of syllabic nuclei, but an underlying feature of consonantal unities. In order to account for the surface occurrences of [a], Anderson proposes that the same rule that spreads the glottal and labial features of a consonant to the following syllabic nucleus also spreads the feature [+low] associated with the consonants to the following syllabic nucleus.

I reject this proposal. First of all, if we accept it we would add another series of consonants to the already complex underlying inventory of consonants. I believe that this leads to a complication, not a simplification, of the Kabardian grammar. Note that the feature [+low] of consonants would then not have the same status as the palatal and labial features of consonants. Palatal and labial features are actual

articulatory properties of consonants. In contrast, the feature [+low] is not connected to any articulatory modification of consonants, and therefore must be essentially considered to be a phonological diacritic.

Observe that whereas palatal and labial features occur only in dorsal consonants, the diacritic [+low] should occur in all consonants and its presence should be indicated only by the quality of the syllabic nucleus that follows the [+low] consonant. But this is equivalent to saying that the feature [+low] is a property of the syllabic nucleus. Complicating the underlying consonantal inventory with consonants that have the diacritic [+low] offers no advantage.

I hence assume that the correct vowel inventory of Kabardian is that in (4), where all of the UG filters in 1.(1), as well as the UG filter in (1), are underlying filters.

I must now account for all of the surface phonetic qualities of the Kabardian vowels. I hypothesize that there are two rules that explain the different qualities of the Kabardian vowels: one of these is a rule of assimilation and the other is a rule of merging. I shall discuss the rule of assimilation first. I propose the rule in (15):

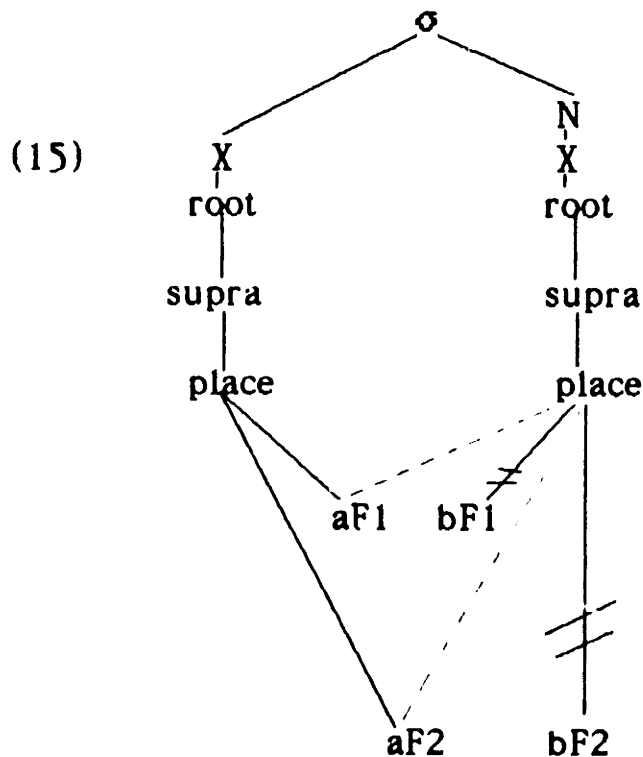

(15) is bidirectional

Rule (15) is a rule of assimilation by which the vowel acquires the terminal features of the adjacent consonant in the onset or in the coda. (see below for an argument in support of this rule). Labial nonrounded consonants and coronal consonants do not affect the quality of the syllabic nucleus in Kabardian, which surfaces as a central [ə] or [a] in this case. This fact indicates that only the terminal features of the consonants that can be terminal features of vowels are spread.

Let us consider the underlying syllables in (16):

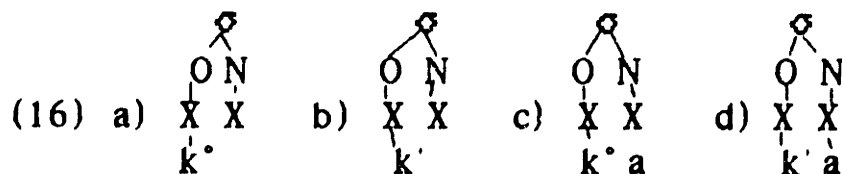

The syllables in (16) have the feature tree representations in (17), respectively:

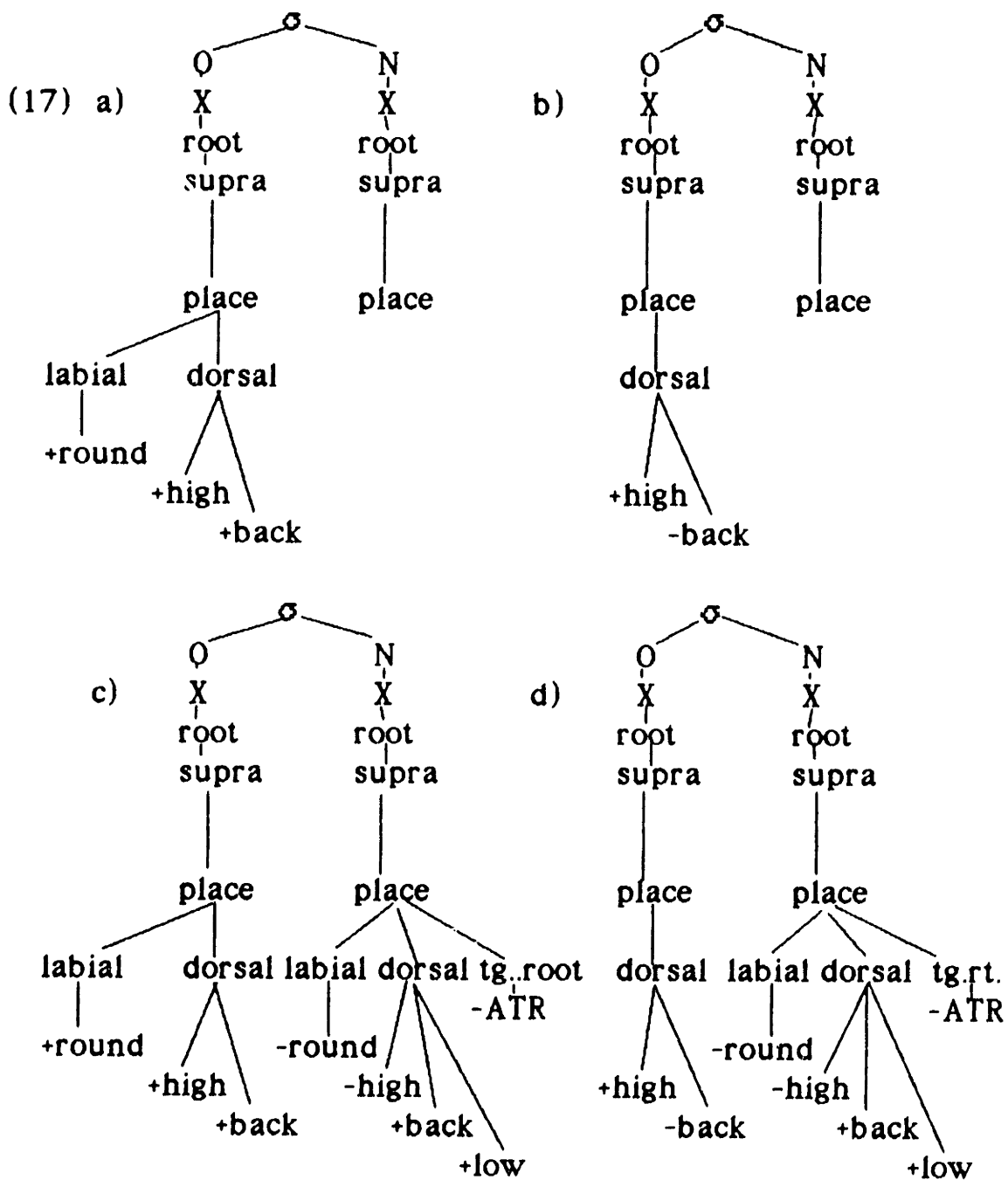

After the application of (15), (17)a)-d) will become (18)a)-d) (I assume that in a series of cases in (18) Steriade's (1982) Shared Features

Convention has simplified the output of the application of (15) by merging nodes dominating the same features):

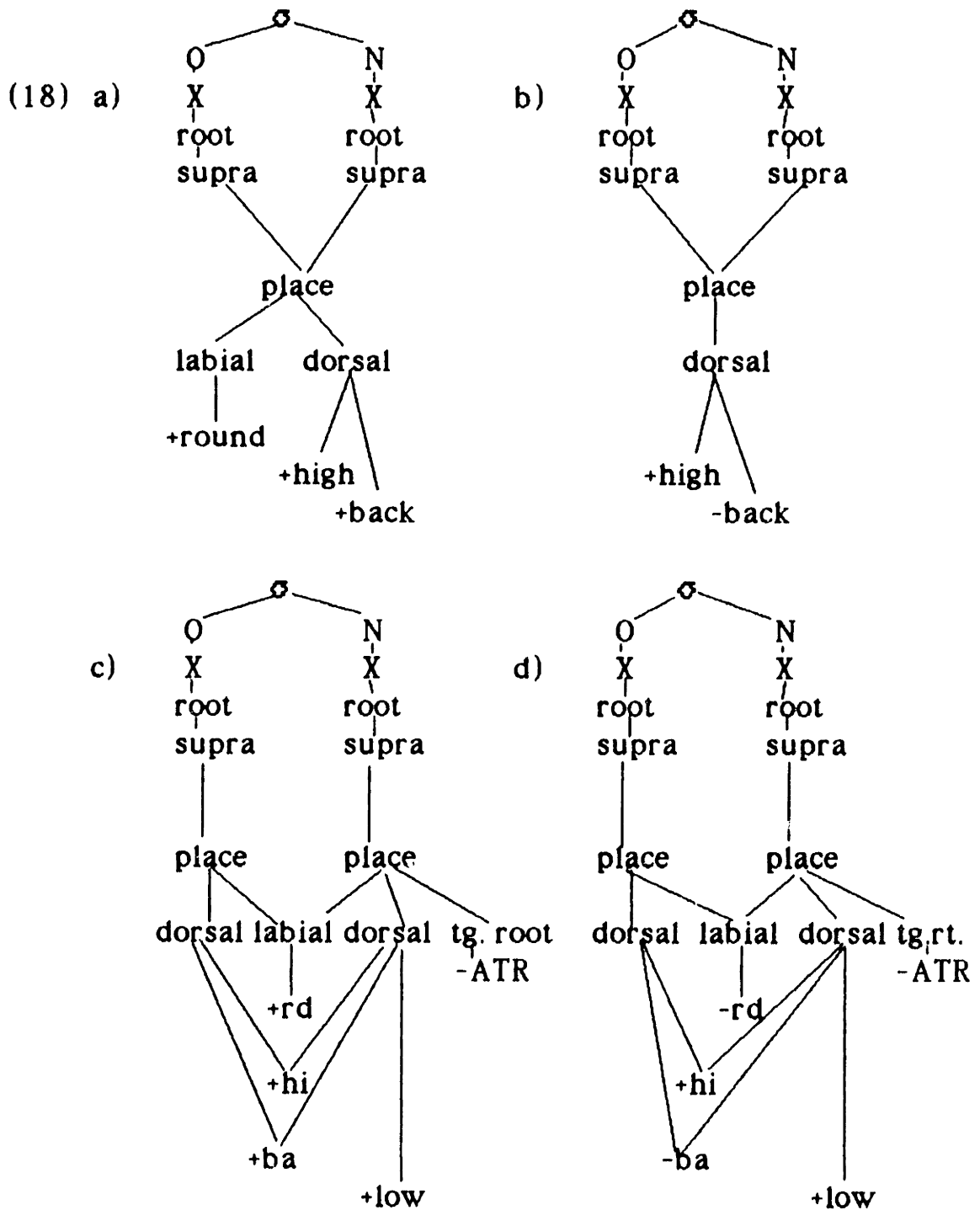

In (18)a) and b) we have the vowels [i] and [u]. These are the vowels

that Kuipers describes as occurring after palatal and labial-velar consonants. In (18)c) and d), we have instead the configuration [+high, +low] disallowed by the UG filter 1.(1)IX), which can never be violated. Kuipers transcribes the vowels that occur after palatal velars and labial velars as \underline{e} and \underline{o} . We can therefore suppose that the clean up rule used to repair this disallowed configuration is negation, so that we obtain the following repair::

[+high, +low] --> ((+high, +low)) --> [-high, -low]

Observe that the assimilation rule cannot be analyzed as a rule that spreads a node higher than a terminal node. If it were such a rule, we would expect that /a/ loses its feature [+low], when it is a target of the assimilation rule. Let us consider (17) d), for example. In this case both the labial features and the dorsal features should be spread. Therefore, if the assimilation rule were a rule that spreads a node higher than a terminal node, we would have to assume that spreads the place node. Thus, when the assimilation rule applies to (17), we would obtain (19):

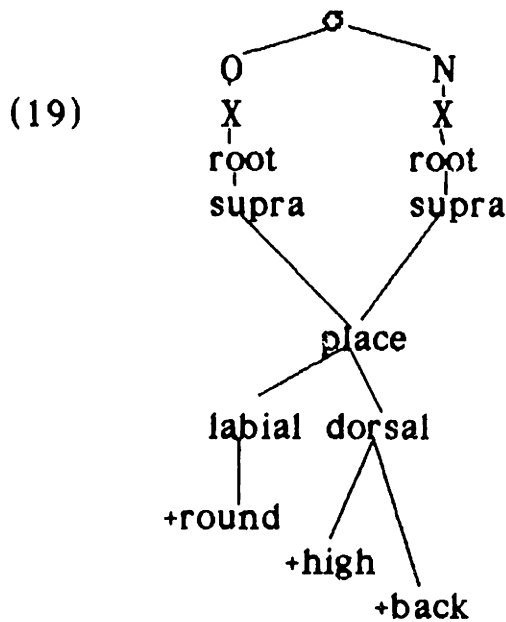

In (19), we obtain the high vowel [u]. But this is not correct. High vowels are obtained only when the target of the assimilation rule is /ə/ and not when the target is the low vowel /a/. In order to explain this fact, we have to suppose that the feature [+low] is not affected by the assimilation rule. This is what we can obtain if the assimilation rule is represented as in (15).

Let us now consider the rule of merging that accounts for the long vowels of Kabardian. We have seen that the long vowels of Kabardian must be derived from the sequence syllabic nucleus + glide, i.e., əy, əw, ay, aw, ah. I assume that only glides can belong to the rime in Kabardian and I formalize the rule of merging as a rule which merges the tree of the vowel with the tree of the following glide and replaces the terminal features of former, if there are any, with the corresponding terminal features of latter, if there are any. This rule can be formalized as in (20):

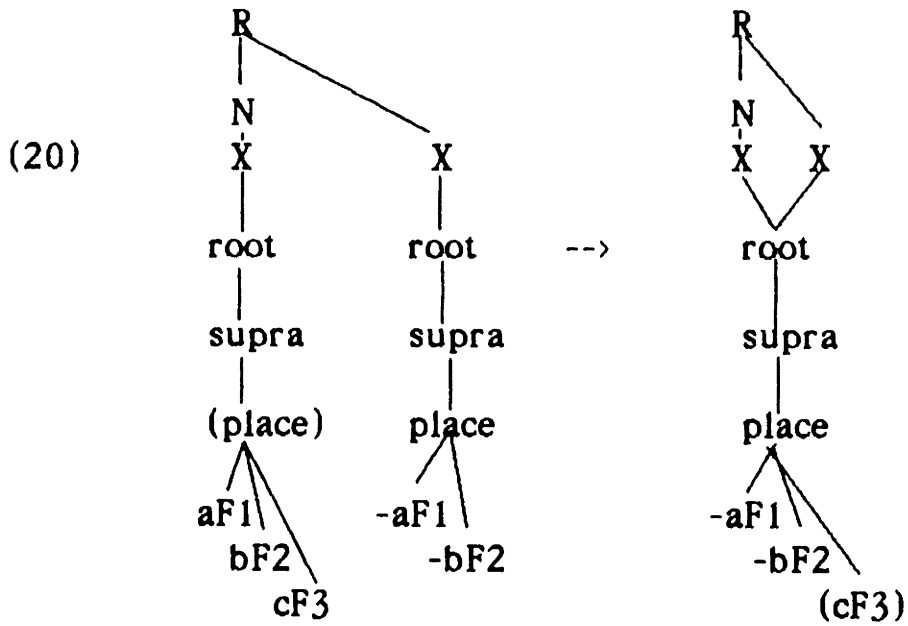

In (21) I present the feature tree representations of the rimes of Kabardian:

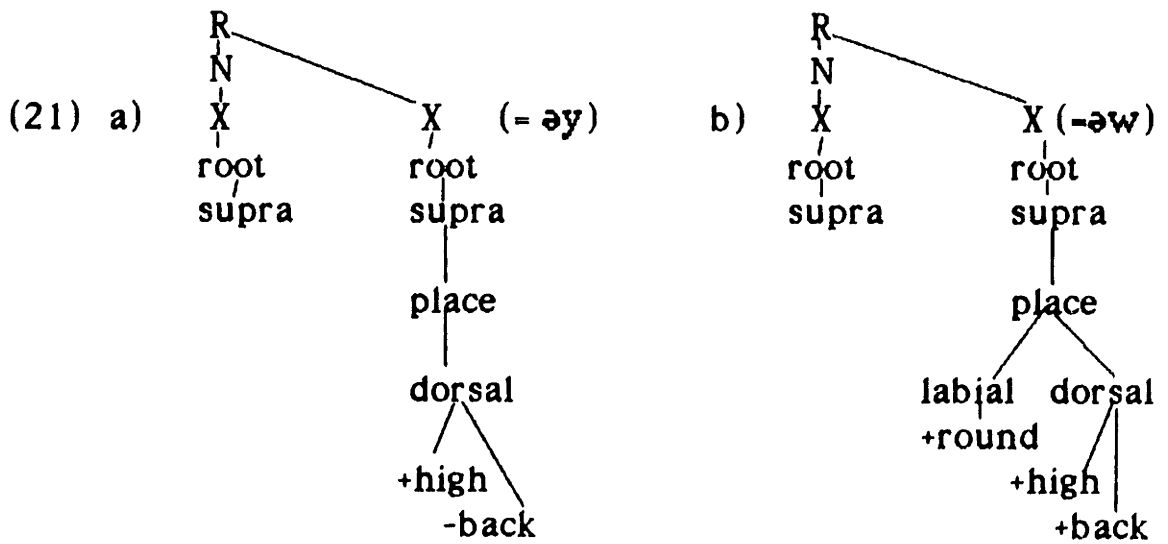

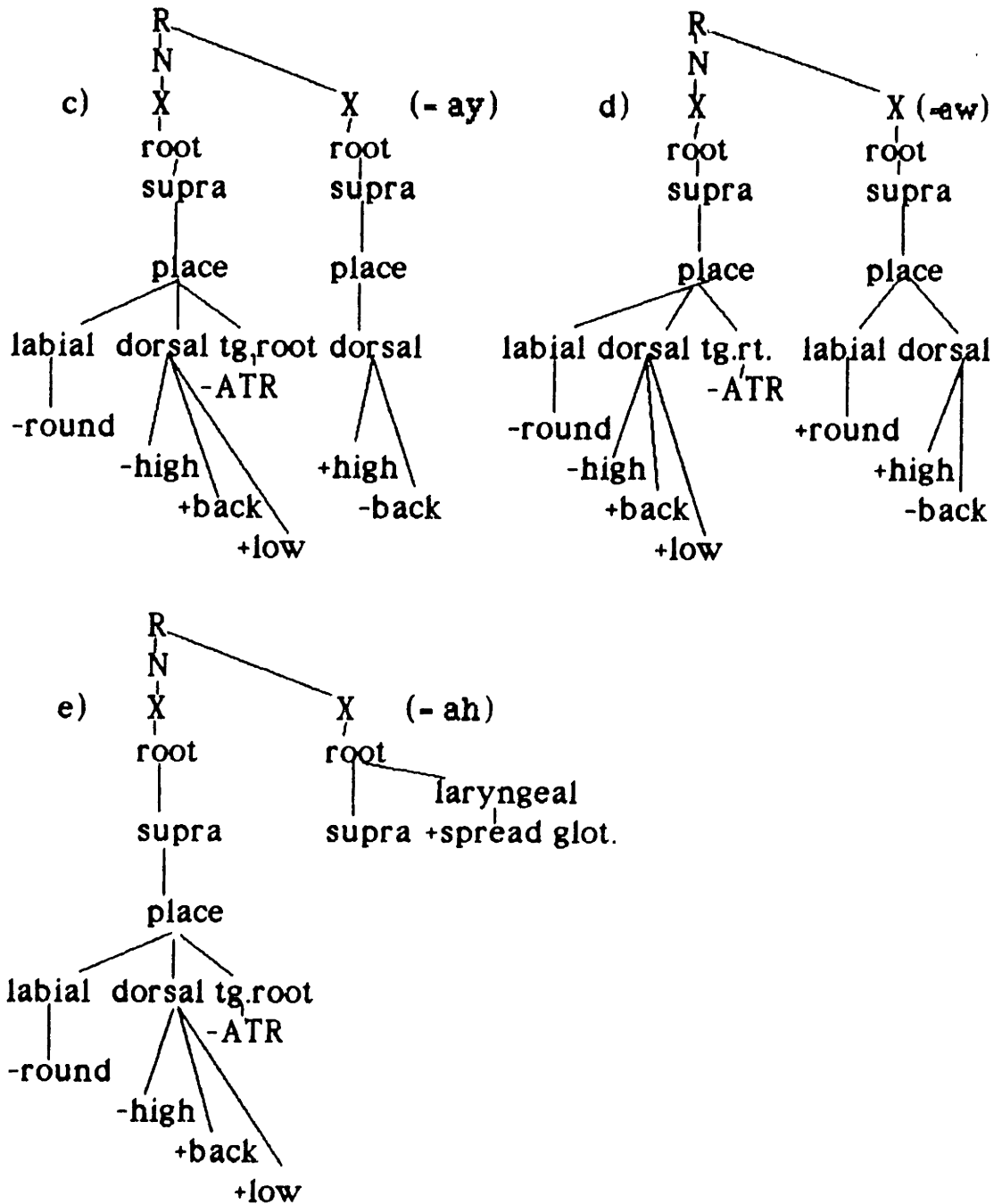

(I assume that the sequence ah is impossible because the laryngeal glide requires that there are terminal features in the syllabic nucleus in order to be articulated.)

Rule (19) changes the rimes in (21) into the configurations in (22):

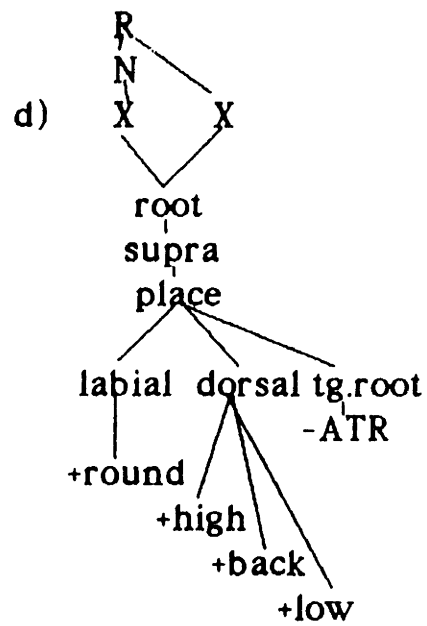
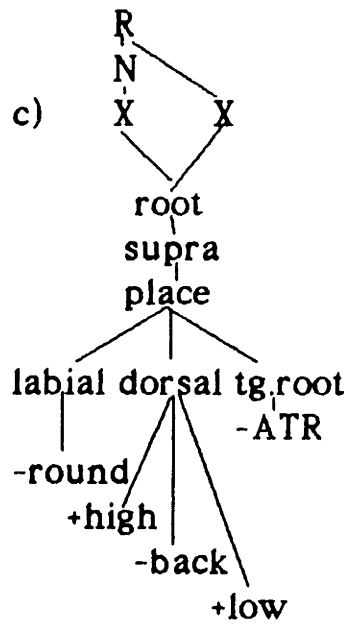
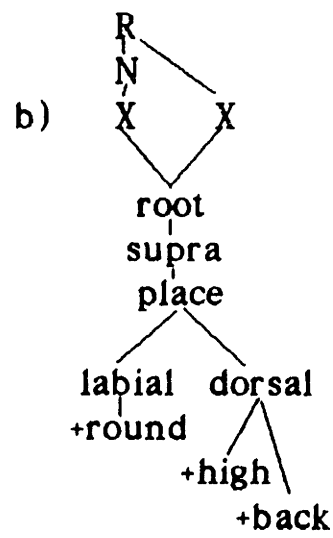
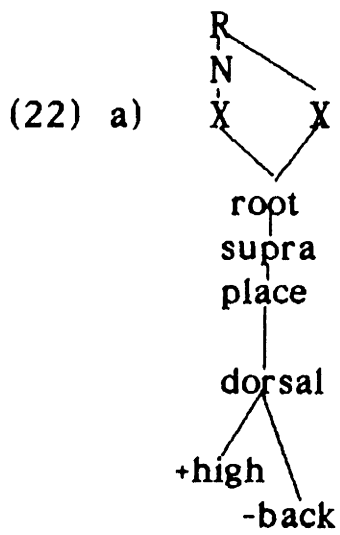

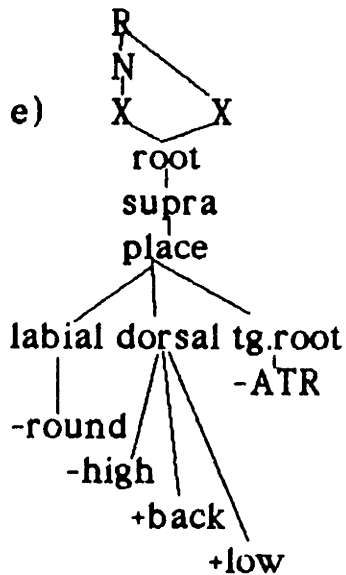

(22)a) represents the vowel [i:], (22)b) the vowel [u:], (22)e) the vowel [a:]. In(22)c) and d) we have the configuration [+high, +low] disallowed by the UG filter 1.(1)IX), which can never be violated. As before, this configuration is repaired by negation. Therefore (22)c)-d) are changed in (23)a)-b):

(23)

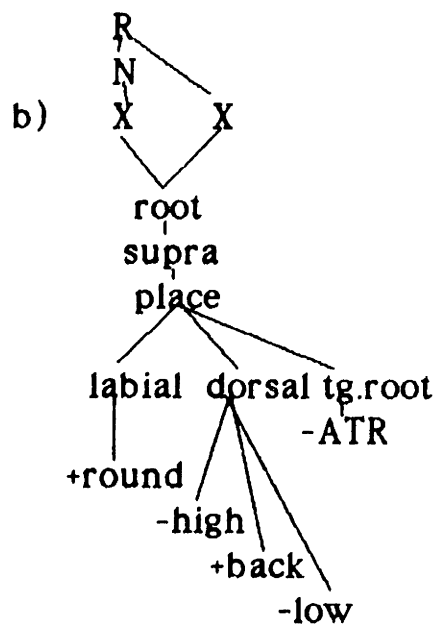
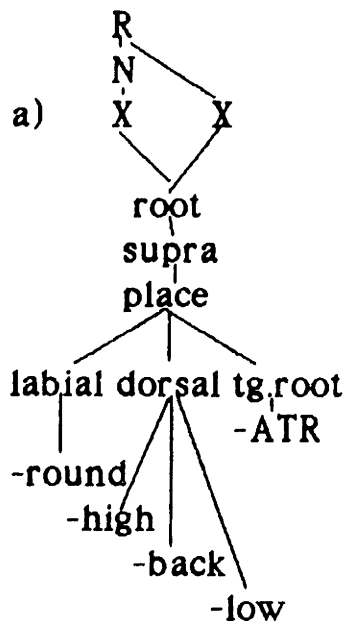

(23)a) and b) represent the long mid-vowels [ɛ:] and [ɔ:]. (No phonetic description of the +/- ATR quality of the long mid-vowels of Kabardian is given in the literature. I assume that they are [-ATR].)

Kuipers observes that the quality of long vowels is more stable than that of short vowels. I assume that this must be explained by hypothesizing that the rule of assimilation (14) applies only to short vowels and that the rule of merging (20) must apply before the rule of assimilation (14). In this way the rule of merging bleeds the rule of assimilation..

Given the wide range of phonetic qualities that are possible in surface representations in Kabardian, we have to hypothesize that principle 9.(16) allows a very high degree of complexity in this language so that configurations of features in violation of underlying filters may surface unchanged. However, given the sketchy description of the different surface vowels in the literature, it is quite difficult to determine what actually surfaces and what is instead repaired.

Finally, I must account for the fact that vowel systems like that of Kabardian or the other western Caucasian languages are quite rare, if not exclusively peculiar to these languages. In order to do this, I propose the following principle:

- (24) The degree of complexity of an underlying vowel system must be superior or equivalent to the degree of complexity of a configuration of features that violates UG filter (2).

Principle (24) establishes that underlying vowel systems should be composed of at least the three vowels /i, u, a/. Thus it excludes vowel systems like that of Kabardian.

Now I hypothesize that the peculiarity of Kabardian and the other western Caucasian languages lies in the fact that they have very complex consonantal inventories, probably among the most complex consonantal systems known, and that it is just this property that permits them to have a reduced underlying vowel system. I thus propose the following principle:

- (25) (24) can be suspended if the underlying consonantal system allows a degree of complexity superior to the degree of complexity X.

At this point in my research, I am unable to individuate what this degree of complexity X is. And so I simply propose that the underlying consonantal systems of the western Caucasian languages allows a degree of complexity superior to the degree of complexity X.

FOOTNOTES CHAPTER 1

1. Observe that I assume that a filter like (3) holds in the phonology of a language if and only if it is an underlying filter of that language and therefore defines a segment or a class of segments that is absent in that language. This deviates from Kiparsky (1981)'s original proposal where constraints like [α voice, +sonorant], which cannot represent any segment, are allowed.

2. M. Yip in Yip (1988) proposes a similar idea, with the difference that the disallowed configurations are not feature bundles, but sequence of features in the phonological string. She proposes that whenever a sequence of features violates the OCP, a series of rules apply to repair this violation. See also C. Paradis (1987) and R. Singh (1987) for similar proposals.

3. On loan phonology see Hyman 1970, Kiparsky 1973, Lovins 1973, 1974.

4. In Section 9, I will present a series of cases in which disallowed configurations of features are not repaired so that they may surface unchanged, and I will account for these cases.

5. In Calabrese (1986), forthcoming a, forthcoming b, I used the term linearization, instead of fission, to name this phenomenon. I believe now that the term fission is more appropriate.

6. Observe that there is an interesting class of exceptions to the rule of metaphony. In Salentino, the words in (i) do not have metaphonic change where expected:

- | | |
|---------------|-----------|
| (i) spekky -u | 'mirror' |
| vekky -u | 'old' |
| superky -u | 'outrage' |
| cuperky -u | 'cover' |

What is characteristic of these exceptions is the presence of a palatal occlusive between the target and the trigger of metaphony. Observe that a velar occlusive does not block the application of the rule in the

same way as we see in (ii):

- (ii) fuek -u 'fire'
 səkk -i 'he dries' siəkk -i 'you dry'
 cərk -i 'he looks for' clərk -i 'you look for'

If the metaphony rule is the autosegmental rule of spreading hypothesized in (3), we can understand why palatal occlusives act as blockers. Let's suppose that the palatal occlusives are different from the velars by their being specified by the features [+high, -back]. They are both dorsal, but palatal occlusives distinctively have the features [+high, -back], whereas velars do not have these features.

Now, we can say that this specification [+high] blocks the spreading of [+high] from the trigger to the target of the metaphony rule, as we can see in (iii):

(iii)

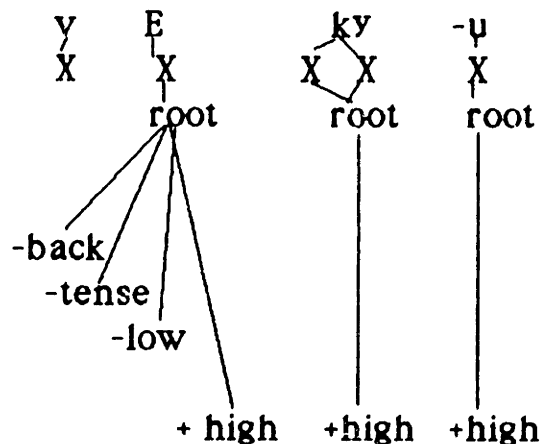

This property of the palatal occlusive can be nicely accounted for only in an autosegmental framework. And therefore, it is an argument for an autosegmental treatment of metaphony. Observe that if this analysis is correct we have also an argument in support of the hypothesis that diphthongization and raising are obtained by the same rule.

However, I should note that the only exceptions to the metaphony rule that I was able to find have [-ATR] front vowels. In my research, I did not come across an exception that displays a different mid vowel. Thus, in northern Salentino we find sequences like ..əkyu, but there are

no sequences like the following: ..ekyu, ..okyu, ..okyu. If the analysis proposed in this note were valid, we should expect to find them. Therefore, I have some doubts about its validity.

7. See chapter 4, for evidence that the diphthong that we obtain by fission is a short diphthong, i.e., a diphthong that is associated with only one timing unit.

8. Another solution would be to hypothesize that the metaphony rule is a rule of diphthongization that affects stressed mid-vowels and assigns an initial high glide to them when they are followed by a high vowel. This rule cannot be formulated as a rule which assigns to the stressed vowel an additional (initial) timing unit associated with a [+high] feature as in (i) because of the facts of central Pugliese discussed in note 7 which show that the diphthong created by metaphony is associated with only one timing unit.

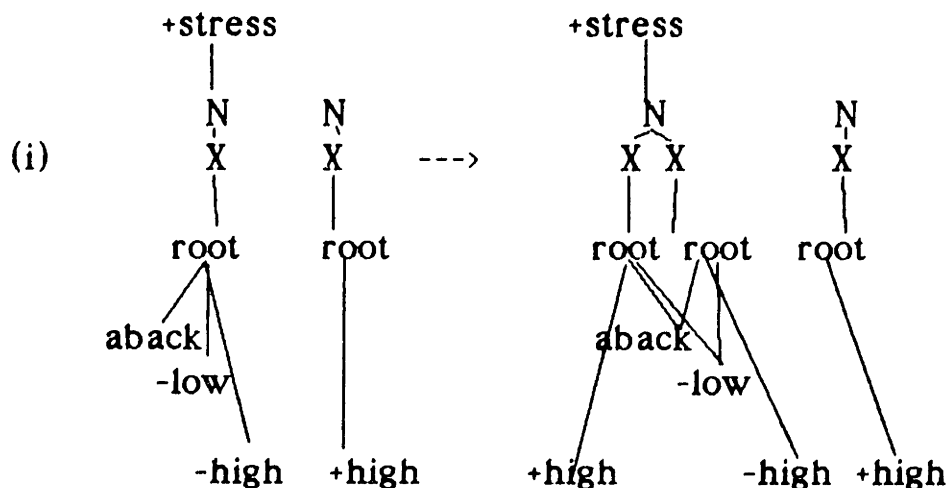

If the metaphony rule cannot (i) for the reasons mentioned above, then it must be a rule that creates a contour segment, where the first subsegment is a high vowel, as in (ii):

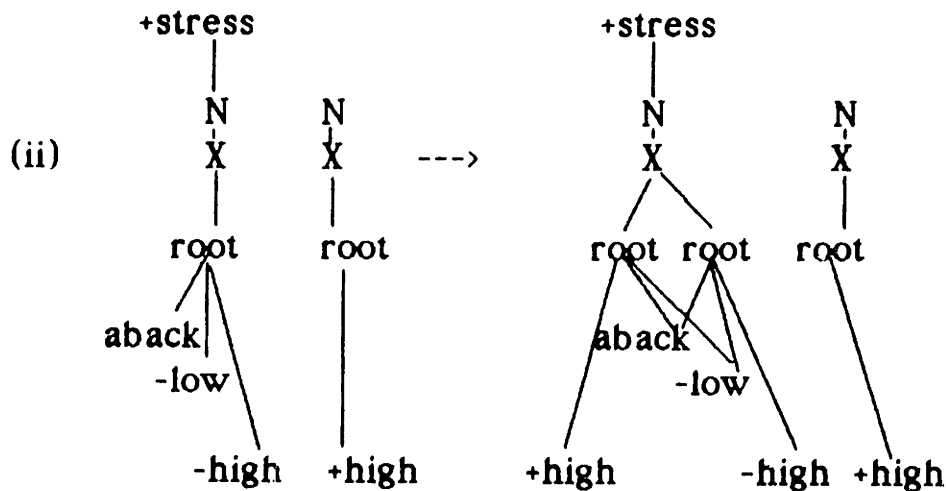

Observe that (ii) is highly stipulative and that there is absolutely no reason to propose it.

Observe then that if we propose (ii) despite its oddness, we must still explain why we do not get [ie], [uo] when the rule applies to mid [+ATR] vowels. We should then stipulate that there is a rule that contracts [ie] and [uo] into high vowels, but not [iɛ], [uɔ]. There is no motivation for this rule either. I can therefore dismiss the possibility of treating metaphony with a single rule of diphthongization.

9. According to the historical grammars (cf. Rohlf's (1966)), the cases in which we find [i, u] from /ɛ, ɔ/ in a metaphonical context are to be explained as cases of reduction of the original diphthongs *iɛ, *uɔ/*ue through the following stages: (I consider the front series) iɛ --> iə --> i₁ --> í, where the crucial trigger is the shift of stress from the second member of the diphthong to the first. The first step of the historical chain is well attested and occurs in dialects in which unstressed vowels are changed to schwas. The second step, however, is more problematic. It should be assimilation or dropping of schwa after a stressed high vowel. In the dialects in which this should happen, there is no synchronic reason for such a rule. Therefore it must be stipulated as an ad hoc change. I believe that the last steps of the historical chain were usually proposed because there was no other alternative explanation for the data. I suppose that such an explanation is now possible in my framework. However, I cannot substantiate it at this point.

Observe that Valente (1975) in a short footnote claims that some

of high metaphonic counterparts of /ε, ɔ/ which he represents as short /i/ and /u/ in his transcription of the dialect of Foggia are reported as long in the literature. I do not understand if his claim is meant to imply that /i/ and /u/ are actually phonetically long when they are the metaphonic counterparts of /ε/ and /ɔ/. This could be considered as evidence for the approach taken in historical grammars. Observe, however, that vowels are always lengthened in open syllables. Therefore, it is not possible to distinguish underlying high vowels from high vowels derived from /ε/ and /ɔ/ in open syllables. The crucial test would be to consider the behavior of the high vowels derived from /ε/ and /ɔ/ in closed syllables. Observe, however, that in this environment vowels are usually short. Research in the field is needed in order to clarify this point.

10. Remember that negation cannot be applied in this case.

11. If no configuration in violation of a filter is created, the rule applies vacuously in this case, since it would assign a value identical to the redundant value. Therefore if a rule spreads [+ATR] onto a feature bundle where [+ATR] is a specified redundant value, essentially no change will occur in that feature bundle.

12. In the data presented by Chumbow (1982), I observed some roots with a disharmonic cooccurrence of mid-vowels:

- (i) a) wòrííwe 'write a book'
 b) wòrédze 'deceive'.

(i)a)-b) would be counterexamples to Chumbow's claim that there is no disharmonic cooccurrence of mid-vowels in roots. A more careful consideration of these examples, however, indicates that they are not true counterexamples to that claim. The domain of harmony in Ogori is restricted to words and the harmony rule cannot cross word boundaries. This may be seen in the following constructions, where there is deletion of the first of two contiguous vowels separated by a word boundary:

- (ii) a) wòré # ìtítšá --> wòrìtítšá
 deceive - teacher deceive the teacher

b) ésá # òrírí --> ésòrírí
 cloth - black black cloth

No harmony rule applies between the different words. Now, the first counterexample (i)b)i)a) belongs to the class of the cognate object-verb and the second (i) belongs to the class of the splitting verbs that I will discuss in note . I believe that these examples should be analyzed as being composed of two different words. Observe example (i) b) and its gloss and compare it with (ii)a) and its gloss.

13. Observe that we have to hypothesize that the morpheme structure condition in (15) applies only to underlying representations and not to representations in which redundant values are filled in. If it were applied to fully specified representation in Ogori, it would block all the root with "neutral" vowels. The restriction of the condition to underlying representation seems a little strange, even though there are other cases of morpheme structure conditions restricted only to underlying representations as we will see in Chapter for the case of Nkaba and Tamil. In this note, I will propose an alternative analysis of root harmony in Ogori which does not use a morpheme structure condition.

Cole (1987) argues extensively that there are harmony systems in which the harmonic feature [F] is placed and spreads on a plane distinct from the [F] plane of the phonological segments. Assuming this proposal, I hypothesize that the feature [ATR] of Ogori is not specified on segments in underlying representations, but is instead specified on an autonomous morphological plane. I then assume that each root is associated with only one value for [ATR]. This plane value for [ATR] is spread onto the unspecified segments contained in the root. Given principle (1), and given that redundant values are unspecified, the feature bundles of /i/ and /u/ cannot be assigned the feature [-ATR] in roots associated with [-ATR], since that would create a configuration in violation of filter (4). In roots associated with [+ATR], the feature bundle of /a/ cannot be assigned the feature [+ATR] since that would create a configuration in violation of filter (3). Therefore, the feature value for [ATR] associated with the root can be assigned freely only to mid-vowels in whose feature bundle it is distinctive. For example,

consider roots like béfùwà 'spoil' and síjáré 'play'. We should have the following underlying multiplanar representations:

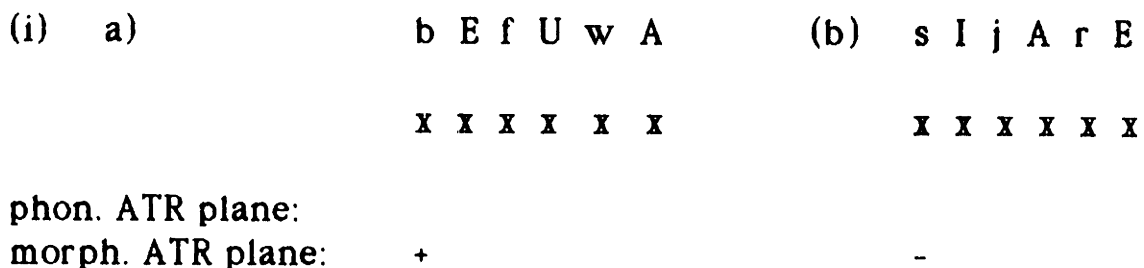

The morphological [ATR] would be spread onto the segments of the root in the following way.

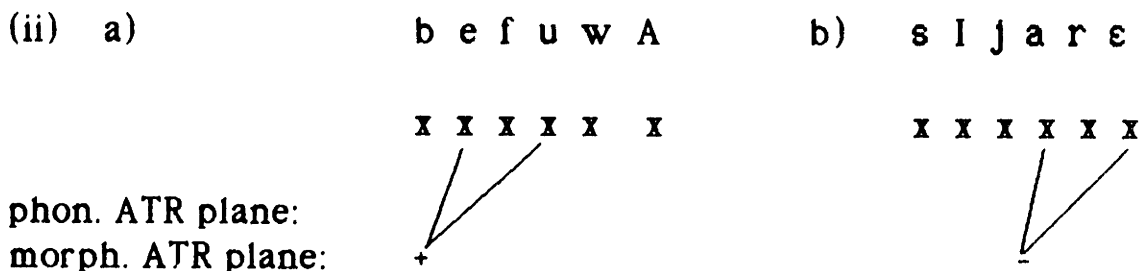

Because of principle 6.(1), [+ATR] cannot be spread onto the feature bundle of /A/ in (ii)a), and [-ATR] cannot be spread onto the feature bundle of /I/ in (ii)b). The value for [ATR] for the high and low vowels will then be filled in by the R-rules (5) and (6) respectively, as we can see in (iii).

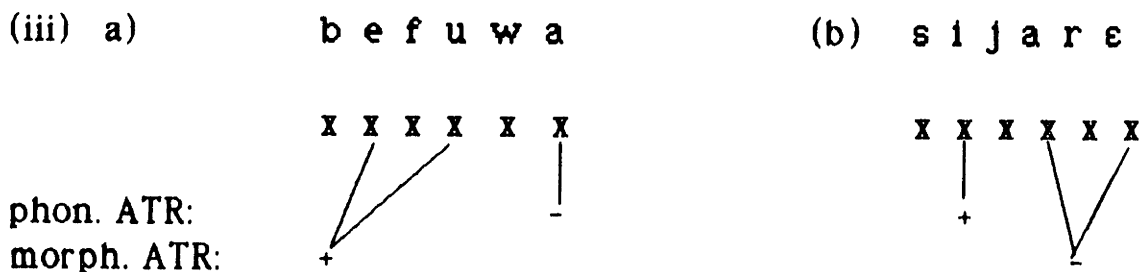

In order to explain why the value for [ATR] of the root is not also spread onto the unspecified vowels of the affixes, I will assume that spreading of the morphological [ATR] is restricted to the vowels in the root. Therefore, the rule that assigns the harmonic value to the affix must be a different one. I shall discuss it in the following paragraphs.

14. At this point, delinking of [+back] must also be applied, as I will discuss below when I consider some sample derivations.

15. In front of deki/dake prefixes in Ogori, we always find the [+ATR] variants of the personal pronouns. Consider the following sentences:

- (i) è - dàkè - nè èbàtà
he - habit. -fling -shoe
he always flings the shoe
- (ii) bí - dàkè - bé - bù úmǔ
they - habit. -beat their goat
they always beat their goat

In (i) and (ii), the personal pronoun prefix should have the variant [-ATR] since the verbal root contains a [-ATR] vowel. In front of the other tense-aspect prefixes, we cannot know what variant of the personal prefix is chosen: they all begin with a vowel and therefore they always assimilate the vowels of the personal prefixes because of an independent rule of vowel assimilation that applies to sequences of vowels:

In front of the negative prefix ma/me, we have the variant determined by the root:

- (iii) á mà jɔ
he - neg. - go
he did not gó
- é mé je
he - neg. call
he did not call

Chumbow proposes that there is a word boundary in front of tense-aspect prefixes. Therefore, given that the harmony rule does not cross word boundary, the harmonic value of the verbal root cannot be assigned to the personal prefix in front of the tense-aspect marker.

Thus, he supposes that if the vowels of the personal pronouns do not receive a harmonic value, they are specified as [+ATR].

I do not know enough about Ogori to challenge Chumbow's idea. However, I do not see why there should be a word boundary in front of tense-aspect morphemes which excludes personal markers from the verbal complex. I propose instead that personal pronouns always belong to the verbal complex, even if they precede a tense-aspect marker, and that there is a special morphological rule triggered by the morpheme dèki/dàkè that assigns [+ATR] to them.

16. Krause (1980) claims that the surface high vowels are phonetically lax. he bases this claim on Skorik(1962)'s description of [i] as being acoustically similar to the English vowel [I] of [pIt] and [tIp]. Krause supposes that the same must be true of [u] as well, although Skorik does not say anything about [u]. Given that Skorik's statement is vague and restricted only to the front vowels, I believe that it is too weak to support the claim that the high vowels are lax.

However, if this were true, one might hypothesize that the filter *[+high, -ATR] is underlyingly violated in S-Chukchi. But there is no known vowel system that contains only high lax vowels. It would be quite strange if S-Chukchi were an exception. Therefore this hypothesis must be dismissed.

Krause (1980) hypothesize that the high lax vowels are derived from underlying tense high vowels by a low level phonetic rule. This is the solution that I would adopt if the high vowels of S-Chukchi were really lax. The problem with this would be that the configuration [+high, -ATR] produced by this low phonetic rule would not be repaired by a clean up rule even if it is disallowed by the underlying filter (5). Now, in Section 9, I hypothesize that clean up rules tend not to not repair disallowed configurations of features that are produced by fast speech phonetic rules. I would, therefore, assume that the rule that creates high lax vowels in S-Chukchi is a fast speech rule so that the high lax vowels produced by this rule can surface without being repaired

17. In Alyutor, a language strictly related to Chukchi (cf. Comrie (1981)), we find the three-vowel system /i, u, a/ and no vowel harmony. This language could be analyzed as a development of "Proto-Chukchi" in which the morphological plane was lost. I hypothesize that the variety of "Proto-Chukchi" that lead to Alyutor differs from the

variety which lead to S-Chukchi in that its harmony rule did not become sensitive to the phonological [-ATR] value. Therefore, also the harmony rule was lost.

18. According to Aoki (1970), there is a considerable individual variation in the degree of rounding of /u/. Thus, [ɯ] occurs as a free variant of /u/.

19. Also negation could be the clean up strategy used to repair the disallowed configuration [+low, +ATR]. In this way we would get the configuration [-low, -ATR]. If we apply also delinking of [+back] we get the vowel [ɛ].

20. D. Steriade (p.c.) pointed out to me an argument proposed by Levin (1987) that clearly supports the hypothesis that French does not have underlying nasal vowels. In French, we can find tautosyllabic sequence nasal vowel + obstruent as in [lãt] (lente) 'slow+fem.', [tõb] (tombe) 'tomb', [ʃãs] 'chance', but we never find a tautosyllabic sequence nasal vowel + sonorant: ṽl , * ṽr . This fact is easily accounted for if nasal vowels are derived from an underlying sequence /v + n/. In this way, in fact, the impossible sequences [ṽl] and [ṽr] should be derived from the tautosyllabic sequences /vnl/ and /vnr/. At this point, it is clear why the sequences [ṽl], [ṽr] are impossible: the reason is that the tautosyllabic sequences /vnl/, /vnr/ are impossible because of the sonority hierarchy. If nasal vowels were underlying segments, we could not have this explanation, and we should expect that sequences like [ṽl] and [ṽr] be possible.

21. Haraguchi (1984) observes that this rule appears to be conditioned by a number of factors. For ex., he mentions that it is blocked in the accented syllable of a two-syllable word when the accented syllable carries high tone. I am not going to discuss these restrictions here.

22. In Romanian, the mid-vowels are not lax, but have an articulation intermediate between lax and tense. I suppose that this articulation is produced by a late phonetic rule.

23. In some varieties of Eastern Lucanian, the non-low vowels have

contextual variants according to whether they are in closed syllables or in open syllables. They are [+ATR] in open syllables and [-ATR] in closed syllables. In this way, we obtain configurations of features in violation of the filters *[-high, +ATR] and *[+high, -ATR], that are underlying in these varieties, if I am correct in assuming that in standard five-vowel systems like that of eastern Lucanian, the set of underlying filters includes all the UG filters in 10.(1) I explain this fact in the following way: I assume that there is a rule that affects non low vowels in these varieties and assigns the feature [+ATR] or [-ATR] to them depending on whether they are in open or closed syllables. This rule will produce I then assume that the grammar of these varieties allows a degree of complexity superior to that of the configuration [+high, -ATR], but inferior to that of the configuration [+low, +ATR]. Therefore, the configurations of features [-high, +ATR], [+high, -ATR] are allowed to surface by 9. (16).

24. Loi Corvetto does specify the quality of mid vowels in word final position. I assume that they have the same quality of of the mid vowels in other positions.

25. Observe that in this way, I hypothesize that epenthetic schwa must be analysed as insertion of a syllabic nucleus that is then phonetically interpreted as schwa

Note now that Halle (1983) proposes that among the different values of vocalic features, only some are connected to positive muscular contractions: [+back], [-back], [+round], [+low]. I suppose that the opposite values are not connected to a muscular contraction. Therefore, [-high], [-low], [+back], [-round] should represent articulatory configurations without a positive muscular contraction. If we combine these features, we should have a vowel that is produced with all the muscles in rest position. What is this vowel? Let us combine [-high], [-low], [+back], [-round] in the same feature bundle, as in (i):

- (i) -high
- low
- +back
- round

(i) is the feature bundle of the vowel [ə]. I propose now that if no

feature value is assigned to a syllabic nucleus, it will surface with an articulatory configuration with all the muscles in rest position. Given what I proposed before, this configuration will have the feature values of the vowel [ə].

26. A similar point was made by Halle (1970) against Kuipers (1960).

CHAPTER II

UNDERSPECIFICATION

In this chapter, I will develop and clarify the theory of underspecification which was introduced in the preceding chapter. The first section is dedicated to a critique of the theory of underspecification proposed by Archangeli and Pulleyblank (cf. Archangeli (1984), Archangeli & Pulleyblank (1986), Pulleyblank (1987)). In Section 2, I shall discuss in more detail Steriade's theory of underspecification which was introduced in Chapter 1. I will argue that although this theory is quite adequate in most respects, it presents problems which must be addressed. In Section 3, I shall introduce a theory of underspecification based upon the theory of UG filters proposed in Chapter 1. I will argue that this theory encompasses Steriade's theory of underspecification, but does not have the problems that Steriade's theory presents.

1. A CRITIQUE OF ARCHANGELI AND PULLEYBLANK'S THEORY OF UNDERSPECIFICATION.

Archangeli (1984) and Archangeli and Pulleyblank (1986) refine and develop Kiparsky (1981), (1983)'s theory of underspecification.

Their idea, following Kiparsky, is that only nonredundant feature values may be included in underlying representations; predictable feature values are filled in by redundancy rules. In this way underspecified representations are obtained. According to them, only a proper subset of the set of distinctive features must be used underlyingly to distinguish the sounds of a language. Moreover, only one of the values of the features that are used is present in underlying representations. The opposite value is supplied by a redundancy rule. Although some redundancy rules are language-specific, Archangeli and Pulleyblank claim that most redundancy rules are not: they are either (i) provided by Universal Grammar--"default rules" in their terminology--or (ii) derived by a general principle of Universal Grammar, the Complement Rule Formation principle. For the first case, they propose that all features have at least one default rule determined by universal markedness theory. This default rule specifies the unmarked value of the feature. For example, let us consider a feature like [nasal]. If we assume that the unmarked value for this feature is [-nasal], then there must be the default rule in (1):

$$(1) [] > [-nasal]$$

This means that in the unmarked case, underlying representations may contain only [+ nasal] specifications. The value [-nasal] is assigned by the default rule to any segment that does not otherwise receive a nasal specification in the phonology.

However, Archangeli and Pulleyblank hypothesize that in certain

cases, considerations of a phonological nature require that a feature value [aF] be underlyingly specified, even though, according to markedness theory, [aF] should be assigned by a default rule. This occurs when [aF] is required in underlying representations either because it occurs as a floating feature or because a phonological rule crucially refers to it at a stage of the phonological derivation in which other feature values appear to be missing. At the same time, they argue that a feature value that should be underlying according to the markedness theory may be underlyingly missing if phonological rules are not sensitive to its underlying presence. At this point, we understand the function of the Complement Rule Formation principle which states that for a given underlying feature value aF, there is a rule like (2) that inserts the complement value -aF of the feature F:

(2) [] > -aF (if aF is an underlying feature value)

Thus, Archangeli and Pulleyblank assume that language-specific phonological considerations may establish underlying specifications different from those expected from the theory of markedness. When this occurs, the default rule inserting an unmarked feature value [aF] is superseded by a complement rule triggered by the underlying presence of aF. This complement rule assigns the feature value [-aF]. For example, Archangeli and Pulleyblank hypothesize on markedness grounds that the feature [+high] is inserted by the default rule in (3):

(3) [] > [+high]

Now if phonological considerations in a certain language require that [+high] be underlying because it is a floating feature value, then a complement rule that supersedes the default rule in (3) is needed. This complement rule is shown in (4):

(4) [] > [-high]

In this way, Archangeli and Pulleyblank establish a difference between universal and language specific redundancy rules: universal redundancy rules are the default rules provided by UG, whereas language-specific redundancy rules are the complement rules triggered by the underlying values established on a language specific basis.

It follows from this that the presence of a default rule in a certain language can be motivated if and only if there is no phonological rule in that language which requires a different underlying specification. This means that in Archangeli and Pulleyblank's approach, one establishes whether a certain feature is unspecified or not in a given language only by considering the phonological rules needed to account for the phonological alternations of that language. Thus for example, they argue that if a phonological rule applies at a stage of incomplete specification and requires the presence of a certain feature, then this feature value must be postulated as present at that stage. Or, for example, they argue that if a rule is not triggered by or skips a segment in which there should be a feature value that could be the trigger or the target of the rule, then this feature value must be postulated as missing at the stage in which the rule applies.

At this point, Archangeli & Pulleyblank's theory runs into a serious problem. Let us examine it by considering an imaginary language L with the seven vowel system in (5):

- (5) i u
 e o
 ε ɔ
 a

in which only the following sequences of non-low vowels are possible: (I consider only the front series and assume that the same properties hold for the back series)

- (6) i...i, i...e, i...ε, e...i, ε...i, e...e, ε...e, ε...ε

In contrast, the following sequence is not possible in L:

- (7) *e...ε

If we consider the facts in (6) and (7) that concern non-high vowels, we are led to hypothesize that in L there is a rule which spreads the feature value [+ATR] from left to right, i.e., to the rule in (8):

- (8) X X (left to right)
 | /
 +ATR

Crucially, rule (8) is not triggered by /i/ in (6).

If one assumes, with Archangeli and Pulleyblank, that one establishes whether a feature is specified or not in a given language only by considering the phonological rules needed to account for the phonological alternations in that language, then the fact that in L (8) is not triggered by /i/ in (6) motivates the assumption that in L [+ATR] is unspecified in a feature bundle that contains the feature value [+high], i.e., the feature bundle of /i/.^[1] We can state this in (9):

(9) [+ATR] is unspecified in a feature bundle that contains [+high] because (8) is not triggered by /i/.

But now, we may ask why (8) is not triggered by /i/ in L. The obvious answer is that in (10):

(10) (8) is not triggered by /i/ because [+ATR] is unspecified in a feature bundle that contains [+high].

If we combine (10) and (9), we would obtain something like (11):

(11) (8) is not triggered by /i/ because [+ATR] is unspecified in a feature bundle that contains [+high], and this is because (8) is not triggered by /i/.

In (11) we have a circular argument. Quite simply, the relationship

between the unspecified status of a feature value and the phonological rule that motivates it cannot be verified. This means that if the argument that a certain feature value is unspecified is based on phonological considerations, then the argument reduces to simply postulating that that feature value is unspecified. There is simply no argument.[2]

Observe that the hypothesis that a feature value is unspecified cannot even be falsified in Archangeli and Pulleyblank's theory. In fact, they propose the following principle:

- (12) A redundancy rule assigning "a" to F, where "a" is "+" or "-", is automatically ordered prior to the first rule referring to [aF] in its structural description.

The effect of principle (12) is that if a phonological rule requires the presence of a certain feature value, a redundancy rule will provide it, even if it is underlyingly unspecified. This means that a phonological rule will never be able to falsify the hypothesis that a certain feature value is underlyingly unspecified, since the required feature value will always be present when the rule applies. As a consequence, in Archangeli and Pulleyblank's model, there is no way to verify the correctness of the hypothesized underlying specifications of feature values.

Archangeli (1984)'s analysis of vowel epenthesis is an example of

the problems of this approach. Archangeli (1984) argues that the simplest analysis for vowel epenthesis is one in which there is insertion of a syllable-head position, devoid of phonemic material. The missing vocalic features are then filled in by the redundancy rules supposed for vowels in general. Given this analysis, the fact that a vowel is an epenthetic vowel in a phonological system implies that this vowel is devoid of phonemic material, i.e., it is unspecified at a certain level. For example, in Spanish, /e/ is the epenthetic vowel (cf. Harris 1969). This leads Archangeli to suppose that /e/ is the unspecified vowel of the Spanish vowel system. She hypothesizes the underspecified system in (13):

(13)	i	e	a	o	u
	high	+			+
	low		+		
	back			+	+

with the redundancy rules in (14):

- (14) a. [] --> [-high]
 b. [] --> [-low]
 c. [] --> [+back, -round] / [____, +low]
 d. [] --> [-round]
 e. [] --> [aback] / [____, -low, around]

At this point, however, we may ask why /e/ is the epenthetic vowel. In Archangeli's model, the obvious answer is that /e/ is the epenthetic

vowel because it is the vowel unspecified in (13), and because there are the redundancy rules in (14). Then it follows that, in her approach, /e/ is the epenthetic vowel because it is unspecified, and /e/ is unspecified because it is the epenthetic vowel. This is impossible to verify.

Another problem for this approach arises when we consider the diachronical development which led to the use of a certain vowel as the epenthetic vowel. Let us suppose a language L in its contemporary stage S_n . L has the vowel system / i, e, a, o, u /. L has a rule that inserts the vowel /e/ in the context $_ \#sC$. According to Archangeli, this fact would motivate the hypothesis that the feature bundle of /e/ is underlyingly unspecified. Therefore the vowel system of L at this stage S_n should be underlyingly specified as the vowel system of Spanish in (13) with the redundancy rules in (14).

Let us now suppose a previous historical stage S_{n-1} of the language L. L at stage S_{n-1} differs from L at stage S_n only in the fact that there is no epenthesis rule in L at stage S_{n-1} , so that we can freely have the sequence $\#sCV$. The change from L at stage S_{n-1} to L at stage S_n is due to adding the epenthesis rule to the grammar of L. The obvious question is now why /e/ was selected as the epenthetic vowel. In Archangeli's approach, we would be forced to say that /e/ was selected as the epenthetic vowel because its feature bundle was underlyingly unspecified. But, this is problematic. Whereas there are motivations (i.e., the rule of \underline{e} -epenthesis) to hypothesize the underlying specifications in (13) in language L at stage S_n , there are no motivations present in L at stage S_{n-1} that motivate /e/ as the

unspecified vowel. Therefore, in L at the stage S_{n-1} , the underlying specifications of the features could only be those derived from the default rules provided by UG, i.e., those in (15) given the default rules in (16):

(15)	i	e	a	o	u
	high	-		-	
	low		+		
	back			+	+

- (16) a. [] --> [+high]
 b. [] --> [-low]
 c. [] --> [+back, -round] / [____, +low]
 d. [] --> [-round]
 e. [] --> [aback] / [____, -low, around]

According to (15), /i/ should be the epenthetic vowel. Therefore, the quality of the epenthetic vowel is not that expected by the underlying specifications in (15), and therefore must be explicitly stated in the epenthesis rule. Thus the epenthesis rule must be that in (17):

$$(17) \quad \emptyset \rightarrow \begin{array}{c} \text{N} \\ \text{X} \\ \text{e} \end{array} / \# \text{ ____ sC}$$

Observe now that there is no reason to believe that the epenthesis rule must be different in L at stage S_n . Therefore, the hypothesis that claims that the epenthesis rule motivates the underlying specification of a

vowel system is not correct.

The problem with an approach like that of Archangeli and Pulleyblank lies in the fact that they use phonological rules to motivate the underlying specification of feature values. At the same time, the properties of these very phonological rules are accounted for by supposing the peculiar underlying specifications that they motivate. In this way a circular argument is created. To avoid this problem, we must establish that phonological rules may not motivate the underlying specifications of feature values. I state this in the following principle:

- (18) Underlying specifications of feature values cannot be motivated by phonological alternations.

Therefore, if we wish to pursue the idea that underlying representations are somewhat unspecified, we must find a different way of determining when a feature value is unspecified. In the next section, I will discuss Steriade (1987)'s theory of underspecification. In Steriade's theory, we find a way to determine the pattern of underspecification of a phonological system that does not violate (18).

2. STERIADE'S THEORY OF UNDERSPECIFICATION

Sterjade (1987) argues that the pattern in which feature values are absent from underlying representations in a given language L is determined simply by considering what the distinctive and non-distinctive assignments of feature values are in the segmental inventory of L. In particular, she proposes that the feature values that are systematically absent from underlying representations of L are the feature values that have a non-distinctive assignment in L. Now distinctive and non-distinctive assignment of feature values in a segmental inventory are determined by the structure of this segmental inventory. A feature value is non-distinctive in a segmental inventory when only that feature value, but not its opposite value, may cooccur with another feature value or set of feature values in the same feature bundle. Thus, for example, in a vowel inventory with no opposition between [+ATR] and [-ATR] low vowels, the value of the feature [ATR] is non-distinctive in a feature bundle that contains the feature value [+low]. In fact in this vowel inventory, only [-ATR], but not its opposite value [+ATR] may cooccur with the feature [+low]. To recapitulate, the structure of the phonological inventory determines what constraints on feature cooccurrence hold in that inventory. These feature cooccurrence constraints indicate what the non-distinctive assignments of feature values are. The hypothesis is then that feature values that are non-distinctive because of these constraints on feature cooccurrence are systematically unspecified. In this way one poses a strict limitation on what can be an unspecified feature. Phonological rules do not motivate the underlying specifications of the phonological system. Only the

consideration of the structure of the inventory can determine its underlying specifications. Therefore, Steriade's approach does not violate principle 2.1.(18) and thus avoids the vicious circles of Archangeli and Pulleyblank's approach.

In Steriade's approach, therefore, feature cooccurrence constraints determined by the structure of the segmental inventory establish that a certain feature value aF is non-distinctive in a feature bundle that contains other feature values. Thus, in the case of the vowel inventory mentioned before, $[-ATR]$ is non-distinctive in a feature bundle which contains $[+low]$ because its opposite value $[+ATR]$ cannot occur in a feature bundle which contains $[+low]$. Steriade proposes that since the feature value $[-ATR]$ is non-distinctive, it is underlyingly absent in feature bundles that contain the feature value $[+low]$. The $[-ATR]$ underlyingly absent in these feature bundles is then filled in at a later stage of the derivation by a rule like (1):

(1) $[+low] \rightarrow [-ATR]$

Steriade also proposes that there are cases in which only one of the distinctive values of a feature is underlyingly specified. In these cases, the opposite value of this feature value is underlyingly absent. It is then filled in at a later stage of the derivation by a rule like (2):

(2) $[] \rightarrow -aF$ (where \underline{a} is the underlying value for F)

She calls the non-distinctive feature values introduced by rules like (1)

R-values, and the rules that introduce them R-rules. On the other hand, she calls the distinctive feature values introduced by rules like (2) D-values, and the rules that introduce them D-rules.

I will repeat the example Steriade uses in order to make the distinction between non-distinctive values and distinctive values clear. Consider the distribution of voicing in a segmental inventory similar to that of English:

(3)

p	t	k	s
b	d	g	z
m	n		
	l		
	r		

In this consonantal inventory, all sonorants are voiced. We do not have any sonorant that is voiceless. Therefore, there is a constraint on feature cooccurrence which determines that only [+voice] can occur in a feature bundle which also contains [+sonorant]. We can thus say that the feature value [+voice] is non-distinctive, i.e., it is an R-value in Steriade's terminology, when it cooccurs with the feature value [+sonorant]. We therefore establish that [+voice] is underlyingly absent in sonorants and that there is a R-rule like (4) which introduces it:

(4) [+sonorant] → [+voice]

In the class of the obstruents, both feature values [+voice] and [-voice]

may occur. They are therefore distinctive values, i.e., D-values in Steriade's terminology. If we assume that only one value of [voice] is underlyingly present, [+voice] for example, then we can assume that the opposite value of [+voice], i.e., [-voice], is underlyingly absent and that there is the following D-rule which introduces it:

(5) [] -> [-voice]

The underlying values for [voice] are thus those in (6):

(6)

	p	t	k	s	b	d	g	z	m	n	l	r
son	-	-	-	-	-	-	-	-	+	+	+	+
cont	-	-	-	+	-	-	-	+	-	-	-	+
voic					+	+	+					

Steriade then shows that the patterns of underspecification obtained in this way appear to be the correct ones by analyzing a vast corpus of facts. She proceeds in the following way: first she establishes the considerations to be used as criterial to establish evidence of unspecified values. She proposes the following:

"The consideration I will appeal to in determining when a redundant value is missing will involve primarily the terms in which locality conditions on phonological rules must be stated. I will assume that if a rule propagating F has applied to a string, then any segment intervening between target and trigger was unspecified for F when the

rule applied. This is represented schematically in (7)[her(2)], where (a) is the rule, (b) is a surface string resulting from the rule and (c) is the underlying representation of the string in (b).

(7)

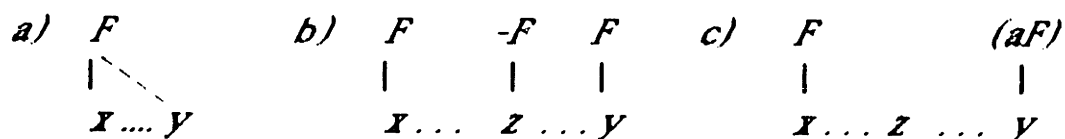

Similarly I assume that dissimilation rules apply under strict adjacency between the target and the trigger autosegment. Therefore if any segment z intervenes on the surface between the target and the trigger of a dissimilation rule, it will count here as underlyingly unspecified for the dissimilating feature" (Steriade (1987)p.339).

This means that only certain phenomena may be considered as evidence for underspecification, i.e., those that can be accounted for in terms of locality conditions, but not others. For example, harmony phenomena in which the same feature is spread on a sequence of segments are not direct evidence for unspecified feature values, according to Steriade. In fact, she assumes that it is not true that phonological rules apply simultaneously to multiple targets. If this were always true, all harmony phenomena would be evidence for the unspecified status of the harmonic feature in the segments target of the rule. Thus, Steriade proposes that harmony phenomena may also be treated by a sequential iterative application of the harmony rule. We can see this in (8), where the vowel harmony rule applies sequentially

letters. I shall not consider that rule here (see McCarthy (1984) for a discussion of this phenomenon):

- | | | | |
|-----|----|------------------------------|-----------------------------------|
| (9) | a) | /beb/ 'drink' | /sint/ 'feel' |
| | | bib- ís | sint- ís |
| | | beb- émus | sent- émus |
| | | beb- ámus | sint- áis |
| | b) | el mál 'the evil' | Il mAdI'rU 'the log' |
| | | en kwénta 'because of' | in il kalíxu 'in the lane' |
| | | po la káfe 'down the street' | pU l ArrU'yU 'along the
arroyo |

As you can see in (9), both mid and high vowels trigger the height harmony rule when they are stressed. The underlying quality of the stem vowel remains unaffected only when the stressed vowel is /a/, as in /beb-amus/ and /sint-áis/. Therefore, the low vowel is not a trigger of the rule. It is not an undergoer or blocker either, as we can see in the forms in (9)b), where the harmony rule does not apply to /a/, but applies across it, and therefore changes /el/ into /il/ in /Il mAdI'rU/ and /po/ in /pU/ into /pU l ArrU'yU/.

The Pasiego facts are easily explained if one hypothesizes that the low vowel does not underlyingly have any value for the feature [high], and that the height harmony rule applies before this value is filled in. Therefore, the harmony rule will be sensitive only to the feature values

[+high] and [-high] of high and mid vowels. Steriade accounts for the fact that vowel /a/ does not undergo the height harmony rule by assuming structure preservation.^[3] The fact that it is not a blocker is then explained by the fact that /a/ does not have a feature value on the tier on which the feature [high] is spread. Therefore, it is possible to account for why /a/ behaves as a transparent neutral vowel in Pasiego.

Thus if we suppose that the feature value [-high] which is non-distinctive in the feature bundle of /a/ is underlyingly absent, as predicted by Steriade's theory, we obtain the correct results.

Ngbaka, a central African language displays an interesting height disharmony (cf. Thomas (1963) and Ito (1984)). Ngbaka has the following vowel system:

- (10)
- | | |
|------|------|
| i(:) | u(:) |
| e(:) | o(:) |
| ɛ(:) | ɔ(:) |
| a(:) | |

The peculiarity of Ngbaka is that vowels of the same height can occur morpheme-internally only if they are identical: therefore, for example, the two high vowels /i/ and /u/ cannot cooccur in the same morpheme, although either may cooccur with an identical vowel in morphemes of the form CiCi, CuCu. The same holds for mid vowels: they can cooccur

morpheme-internally only if they are identical. The low vowel however, is an exception since it can cooccur inside a morpheme which contains any of the following mid vowels /e, o, ε, ə/, as is shown in the following examples: /kalo/ 'chair', /mona/ 'navel', /kakpe/ 'slave'. Steriade, following Ito (1984), proposes that tautomorphemic V(C)V sequences with identical vowels involve a single multiply-linked vocalic autosegments rather than involving distinct identical vowels. Given this, vowel disharmony of Ngbaka can be accounted for by a constraint like that in (11) which blocks sequences of identical values for [high] morpheme-internally:

$$(11) \quad *[\text{ahigh}][\text{ahigh}]$$

$$\quad \quad \quad \begin{array}{c} | \qquad \qquad | \\ [\text{X} \qquad \qquad \text{X}] \end{array}$$

But now the fact that /a/ can cooccur with mid-vowels indicates that its feature value [-high] is not present at the stage in which (11) applies. This is what is expected in Steriade's approach given that [-high] is a non-distinctive value in the feature bundle of /a/.

In many vowel systems, there is no opposition between [-back] and [+back] low vowels. Therefore the value for [back] is non-distinctive in a feature bundle which also contains the feature value [+low]. In these systems, only the feature value [+back], and not the feature value [-back], can occur in the feature bundle of the low vowels. We should therefore expect that [+back] is underlyingly absent in a feature bundle that contains [+low].

Tamil, a Dravidian language of Southern India, has the following vowel system: / i, e, a, o, u /. Tamil (cf. Christdas (1986)) is characterized by the fact that the front vowels /e/ and /i/ do not occur underlyingly (i.e., morpheme-internally, before phonological rules apply) after the front glide /y/. Nor do the back vowels /o/, /u/ occur in underlying representations after the back glide /w/. In contrast, the unique low vowel of Tamil can occur underlyingly after both /y/ and /w/. The Tamil facts may be accounted for by supposing that there is a constraint which prohibits vowels from having a value for the feature [back] identical to the feature value of the preceding glide. The behavior of /a/ with respect to this disharmony constraint indicates that the low vowel does not have an underlying value for [back]. If it had an underlying value for back, the constraint would affect it. This is what should be expected since there is no distinctive assignment of [back] in the feature bundle of low vowels.

In Ainu (cf. Ito (1984)) we found a situation similar to that of Tamil. Ainu has a five-vowel system like that of Tamil. In Ainu, transitive verbal stems take the form CV_i C-V_j where V_j is either a copy of the preceding vowel or a high vowel whose value for backness differs from that of the preceding non-low vowel. Examples of the case in which V_j is a copy of the preceding vowel are /tem-e/ 'to measure', /yoko/ 'to aim'; examples of the case in which V_j is a high vowel whose value for backness differs from that of the preceding non-low vowel

are /sir-u/ 'to rub', /pok-i/ 'to lower'. Ito (1984) proposes that cases like /yok-o/ must be analyzed as having a single, multiply-linked vowel. In cases like /pok-i/, the suffixal vowel is high and undergoes dissimilation: it is [-aback] after a stem with [aback] specification. What is of interest to us is the fact that the low vowel /a/ is neutral in this process and it occurs with both /u/ and /i/ as can be seen in the following forms: /kar-i/ 'to rotate' and /ram-u/ 'to think'. This property of /a/ in Ainu can be accounted for if the feature value [+back] is underlyingly absent in the feature bundle of /a/ and if the dissimilation rule of Ainu applies before underlyingly absent values are filled in. This is yet another case in which the phonological inventory indicates that the value for [back] is non-distinctive in the case of low vowels. Therefore we should expect that it is underlyingly missing in their feature bundle. This prediction is correct.

As I mentioned above, in many systems there is no opposition between [+ATR] and [-ATR] low vowels. In these systems we have a unique low vowel which has the feature value [-ATR]. In these systems, therefore, [-ATR] is a non-distinctive feature value in feature bundles which contain [+low]. We thus expect that this feature value is underlyingly missing. And indeed, this is what we find. For example let us consider Kinande, a Bantu language spoken in Zaire. Kinande has the vowel system in (12):

Kinande displays further evidence that non-distinctive feature values are underlyingly missing.

Let us now consider the correlation between the features [back] and [round] in vowel systems. In many vowel systems, there is a biunivocal correlation between these two features in the case of non-low vowels. In these systems, all non-low front vowels are unrounded and all non-low back vowels are rounded. One of the two feature values [a back] and [a round] must then be non-distinctive in a feature bundle that contains the other. The evidence seems to be that it is the feature value [a round] which is non-distinctive, as we will see in Maori. However, regardless of which feature value is non-distinctive in a given language, the important point is that the non-distinctive value appears to be underlyingly missing. This is what is predicted by Steriade's theory.

Maori (cf. Krupa (1968)) has the standard five-vowel system in (14):

(14) i u
 e o
 a

Observe that in (14) all non-low front vowels are unrounded and all non-low back vowels are rounded. Therefore in the case of non-low vowels, either the feature value [a back] or the feature value [a round]

is non-distinctive, and therefore underlyingly absent.

Maori, like other Malayo-Polynesian languages, presents an interesting constraint on morpheme structure: it prohibits the morpheme-internal cooccurrence of labial segments. Therefore, the following types of morphemes are not possible in Maori: /mVpV/, mVwV/, /wVpv/, hwVmV/, /wVhwV/, pVmV/. This prohibition can be represented by a condition that blocks the cooccurrence of labial segments inside a morpheme:

$$(15) \quad * [\dots \underset{\text{lab}}{\text{X}} \dots \underset{\text{lab}}{\text{X}} \dots]_{\mu}$$

Now, it is interesting to consider how the rounded vowels /o/ and /u/ behave with respect to the constraint in (15). First of all, the rounded vowels /o/ and /u/ are neither incompatible with tautomorphemic labials nor incompatible with each other. Secondly, a sequence of labial consonants separated by a rounded vowel is ill-formed in the same way that a sequence of labial consonants separated by unrounded vowels is illformed: neither /*mawa/ nor /*mowa/ occur. It is clear, therefore, that the constraint in (15) is not sensitive to the presence of labiality in the rounded vowels. This fact can be straightforwardly accounted for if we suppose that the feature value [a round], which is [+round] in this case, is missing in underlying representations. Thus we can simply say that the constraint in (15) applies on underlying representations.

The Maori facts can therefore be accounted for if [around] is considered to be the non-distinctive feature value in the pair [around], [aback], so that it is underlyingly absent.

Cantonese has the vowel inventory in (16): (A is a tense low vowel)

(16)	i	ü	u
	ɪ		ʊ
	e	ø	o
	ɛ	ɔ	ɔ
		A	
		a	

In (16), although not all rounded vowels are back, all non-low back vowels are rounded. The consequence of this is that [+round] is non-distinctive in a feature bundle that contains [+back]. We should then expect that this feature value is underlyingly missing in such feature bundles. And indeed, this is what we actually find.

Cantonese has a series of three apparently distinct labial disharmony constraints that operate inside the syllable (cf. Yip (1987)): an onset labial may not be followed by a front rounded vowel (ɜ, ø, ü); a rounded vowel, front or back, may not be followed by a labial consonant; an onset labial may not be followed by a coda labial. The first constraint disallows syllables like /pø/ but allows /po/. The

second constraint disallows /op/ as well as /öp/. The third eliminates sequences like /pam/. It is possible to argue that the same constraint underlies all three prohibitions (cf. Yip (1987)), the constraint in (17):

$$(17) \quad *[\dots X \dots X \dots]_{\sigma}$$

$\begin{array}{c} | \quad | \\ \text{lab} \quad \text{lab} \end{array}$

This constraint determines the way in which segments are syllabified and it is sensitive to when their labial specifications are introduced. Steriade assumes that [+round] is underlyingly specified in the case of feature bundles which contain [-back]. Therefore the segments that are underlyingly specified for labiality are the labial consonants and the front rounded vowels. Now, if it is correct that non-distinctive values are underlyingly missing, it is possible to account for all of the facts. When the string of segments undergoes the first rule of syllabification, i.e., the formation of CV syllables, only underlying feature values are present. Therefore the constraint in (17) blocks only underlying labial values: thus only /po/ will be blocked, but not /po/, since in the last case the feature value [+round] is underlyingly absent. [+round] is then filled in before the other rules of syllabification apply. Thus, when these rules apply, /o/ and /u/ are specified as labials and therefore their presence is constrained by (17). Thus, the rule of syllabic coda incorporation cannot incorporate a labial consonant in a syllable containing /o/ or /u/ since these vowels are labial at this stage of the derivation. And therefore the structural description of (17) is met. For the same reason, a labial coda cannot be incorporated into a /pV/ syllable.

Cantonese then provides further evidence that non-distinctive values are underlyingly missing.

Steriade has three cases that deal with properties of consonantal systems and show that the hypothesis that non-distinctive values are underlyingly missing is also correct in the case of consonantal systems.

In Chumash (cf. Poser (1982) based on an unpublished thesis of R.B. Applegate), there are the following coronal consonants /t/, /l/, /n/ /s/ and /š/. Now /t/, /l/, /n/ and /s/ are characterized by having the feature value [+anterior], /š/ by having the feature value [-anterior]. Observe now that the contrast between [+] and [-] values for the feature [anterior] is present only in the case of continuant consonants. All of the other consonants are [+anterior]. This means that the feature value [+anterior] is non-distinctive in the case of the consonants /t/, /l/, /n/. We can expect then that the feature value [+anterior] is underlyingly missing in the feature bundles of these three consonants. And in fact, this is the correct prediction. In Chumash, there is a harmony rule by which the feature value for [anterior] of the rightmost sibilant is spread onto the preceding sibilants, delinking whatever value for [anterior] they have. We can see the effect of this harmony rule in (18):

- (18) a) k - sunon - us 'I obey him' = k - šunon- š 'I am
obedient'

- b) ušla 'with the hand' ⇨ usla - siq 'to press firmly by hand'
- c) uqsti 'of throwing' ⇨ š-uxšti-meš 'throw over to'

Intervening segments are transparent to the rule. In particular, the coronal segments /t/, /n/ and /l/ are transparent to this harmony rule: they do not trigger or block it, as we can see in (19):

- (19)a) š-**ap**i-tšo-it 'I have good luck' ⇨ s-**ap**i-tso-us 'he has good luck'
- b) k-šunon-š 'I am obedient' ⇨ k-sunon-us 'I obey him'
- c) ha-s-xintila 'his Indian name' ⇨ ha-š-hintila-waš 'his former Indian name'

Observe that the harmony rule requires that both specifications [+anterior] and [-anterior] be underlyingly present in the case of the sibilants. In fact underlying /s/ is changed to /š/ as in (18)c) and (19)c), and underlying /š/ is changed to /s/ as in (18)b). Therefore, it is very interesting that the rule is not sensitive to the feature value [+anterior] of /t/, /n/ and /l/. This lack of sensitivity is straightforwardly accounted for if this feature value is underlyingly absent in the case of the feature bundles of /t/, /n/ and /l/. And this is what is predicted by the fact that [+anterior] is non-distinctive in these feature bundles.

In most languages, we find an opposition between [+] and [-]

values for the feature [lateral] only in the case of non-nasal sonorants, the so called liquids. All of the other consonants, glides and vowels are specified as [-lateral]. This means that the feature value [-lateral] is non-distinctive in the case of non-liquid segments, while the two feature values [+lateral] and [-lateral] are distinctive in the case of liquids in systems that show a contrast between lateral and non-lateral liquids. We therefore expect that the feature value [-lateral] is underlyingly missing in the feature bundles of non-liquids.

The case of dissimilation of laterals in Latin appears to support this hypothesis. The phenomenon concerns the behavior of the suffix -alis. The facts are the following: with stems in which a lateral is not present, the suffix appears with the form -alis, which we suppose is its underlying form:

- (20) nav -alis
 semin -alis

However with stems in which a lateral is present, the suffix appears with the form -aris:

- (21) a) sol -aris
 b) aliment -aris
 c) milit -aris
 d) line -aris

The interesting and important fact here is that the presence of an /r/

between the two laterals blocks the application of the rule:

- (22) a) littor -alis
- b) flor -alis
- c) sepulchr -alis

Observe that only /r/--no other sonorant or coronals--can block the application of the dissimilation rule, as we can see in (21).

How can we explain this fact? The feature [-lateral] associated with /r/ represents the distinctive value with respect to the [+lateral] of /l/. The feature value [-lateral] associated with all the other consonants instead represents a non-distinctive value for [lateral]. In fact the distinction [+/- lateral] can be relevant only in the case of liquids in Latin. In the case of non liquid consonants, the specification - for [lateral] represents a non-distinctive value in Latin.

Therefore, the phenomenon of lateral dissimilation in Latin may be analyzed by proposing the following rule of dissimilation:

- (23) [+lateral] > [-lateral] / [+lateral] ___ in the suffix -alis

The rule applies on the tier where the feature [lateral] is placed, and is sensitive to adjacent underlying specifications for [lateral]. We can therefore analyze (21)a) in the following way:

Ito and Mester (1986) have shown that this prediction is correct. In Japanese, there is a rule of voice dissimilation which prevents the surfacing of more than one voiced obstruent in the same stem (Lyman's law). There is also a rule which voices stem-initial obstruents in the second member of a compound (Rendaku). What is of interest to us at this point is the interaction between these two rules: Lyman's rule in fact creates violations of Rendaku, precisely in the case where Rendaku would produce a stem-internal sequence of two voiced obstruents. Now, observe that the presence of a sonorant inside the stem does not produce a violation of Rendaku, although a sonorant superficially has the specification [+voice]. This is illustrated in the following examples:

- (26) a) /garasu tana/ 'glass shelf' --> garasu dana (by
Rendaku)
- b) /kami kaze/ 'divine wind' --> kami gaze (by
Rendaku) --> kami kaze (by Lyman's law)

In (26)b) the presence of a voiced obstruent in the stem triggers the application of Lyman's law, so that a violation of Rendaku is superficially created. In (26)a) the presence of a sonorant does not trigger the application of Lyman's law, so that Rendaku is not violated. The obvious explanation for this fact is that the non-distinctive value [+voice] in the case of sonorants is underlyingly missing and is filled in only after Lyman's law has applied. Therefore Lyman's law will be triggered only by the specification [+voice] of voiced obstruents. This hypothesis is supported by the fact that Lyman's law applies when two

voiced obstruents are separated by a sonorant, as we can see in (27):

(27) /taikutsu ŝinogi/ 'time killing' --> /taikutsu jinogi/ (by R.) -
-> taikutsu ŝinogi (by L.L.)

(27) indicates that the specifications [+voice] of the voiced obstruents are adjacent on their own tier. This means that the specification [+voice] of the sonorant is absent when the Lyman's law applies.

In conclusion, there is overwhelming evidence that if there is any feature value that is underlyingly unspecified, that feature value is a non-distinctive feature value. The hypothesis that non-distinctive feature values are underlyingly unspecified is then well supported.

Such evidence, however, is missing for the case of distinctive feature values. In fact, as Steriade points out, we have evidence of the contrary. In several cases, it appears that both distinctive values of a given feature must be underlyingly present. This is the case of the rule of disharmony of Tamil that we discussed previously, for example. The disharmony constraint of Tamil applies in underlying representations and requires that non-low vowels do not occur after glides that have the same value for the feature [back]. This means that the [+] and [-] values for the feature [back] of non-low vowels must be underlyingly specified (cf. Christdas (1986)). Therefore, in Tamil both distinctive values of [back] must be underlyingly present. The same holds for Ngbaka. We have seen that in this language there is a constraint on the

cooccurrence of vowels of the same height morpheme-internally: vowels of the same height can cooccur inside the same morpheme only if they are identical. This constraint holds for both the high vowels and the mid vowels; it does not hold for low vowels. Since this constraint should be formulated as a prohibition against sequences of identical specification for [high] in underlying representations, we are forced to assume that both values for [high] occur underlyingly in the case of non-low vowels. Chumash also shows the same fact: both feature values [+anterior] and [-anterior] appear to be underlyingly present in the case of continuant consonants. And in Latin, too, it is possible to argue that both of the feature values [+lateral] and [-lateral] are underlyingly specified in the case of non-nasal sonorants.

Steriade, however, shows that there are two cases in which a distinctive feature value seems to be underlyingly missing: Rendaku in Japanese and the vowel harmony of Finnish. I shall discuss these two cases in section 4.

There are problems in Steriade's theory, and the problems concern the status of the R-rules. The function of the R-rules is that of introducing the underlyingly absent non-distinctive feature values, i.e., R-values in Steriade's terminology. The form of the R-rules should then be determined by the way in which feature values are distributed in a segmental inventory. Consider a segmental inventory I in which a feature value [aF] must cooccur with a feature value [bG], whereas the feature value [bG] does not have to cooccur with [aF]. This means that in I, whereas [bG] is non-distinctive in a feature bundle that contains [aF],

[aF] is distinctive in a feature bundle that contains [bG]. If it is correct to hypothesize that non-distinctive values are underlyingly absent, we are then forced to propose the R-rule (28) in I:

$$(28) \quad [aF] \rightarrow [bG]$$

This, for example, is the case of a consonantal system that contains voiceless stops, voiced stops and sonorants. In this consonantal system, the feature value [+sonorant] must cooccur with the feature value [+voice], whereas the feature value [+voice] does not have to cooccur with the feature value [+sonorant]. The feature value [+voice] in this consonantal system can occur in both a feature bundle that contains [-continuant] and a feature bundle that contains [+sonorant]; [+sonorant], on the other hand, can appear only in a feature bundle that contains [+voice]. Therefore, [+voice] is a non-distinctive value in a feature bundle that contains [+sonorant] and we have to hypothesize the R-rule in (29):

$$(29) \quad [+sonorant] \rightarrow [+voice]$$

There is no problem with proceeding in this way. A problem does arise, however, when there is biunivocal correspondence between feature values. This case occurs when two feature values imply each other. In this case, there is no way to determine from the distribution of the feature values which feature value is the non-distinctive one. Let us suppose, for example, a three-vowel system /a, i, u/ fully specified as in (30):

(30)	a	i	u
high	-	+	+
low	+	-	-
back	+	-	+
round	-	-	+
ATR	-	+	+

In (30), there are a series of feature values in biunivocal correspondence: [+low] and [-high], [-low] and [+high], [+high] and [+ATR], [-low] and [-ATR], [+round] and [+high], [-back] and [-round], [+back] and [+round]. There is no procedure in Steriade's approach that allows one to determine the non-distinctive values in those pairs. Therefore, we could have either R-rules like [+low] → [-high], [+high] → [+round], or R-rules like [-high] → [+low], [+round] → [+high]. Observe that the feature value at the left of the arrow in the R-rule must be an underlying feature value. Therefore, an approach like Steriade's allows different possible underlying specifications; in fact, (30) could be underlyingly specified at least as in (31)a) or (31)b):

(31) a)	a	i	u
high		+	+
low	+		
back		-	+
round			
ATR			

(31) b)	a	i	u
high	-		
low		-	-
back		-	+
round			
ATR			

(31)a) would be filled in by the R-rules in (32)a), and (31)b) would be filled in by the R-rules in (32)b):

(32) a) [+high] --> [-low]
 [+low] --> [-high]
 [+low] --> [+back]
 [+high] --> [+ATR]
 [+low] --> [-ATR]
 [+low] --> [-round]
 [+back] --> [+round]
 [-back] --> [-round]

(32) b) [-low] --> [+high]
 [-high] --> [+low]
 [-high] --> [+back]
 [-low] --> [+ATR]
 [-high] --> [-ATR]
 [-high] --> [-round]
 [+back] --> [+round]
 [-back] --> [-round]

Every linguist would accept (31)a) as representing the correct underlying specifications of (30), but not many linguists would accept (31)b) as representing the correct underlying specifications of (30). The point is that it seems natural to characterize /a/ as a [+low] vowel. Moreover, [+low] seems to be the underlying value of /a/ in many phonological systems, as we have seen in Pasiego and Ngbaka. It would be strange that in the simplest vowel system /a, i, u/, /a/ is not underlyingly [+low].

In order to avoid this kind of problem, Steriade proposes two constraints on possible R-rules: R-rules can be of two classes. First, there is a class of R-rules that express enhancement relations in Stevens, Keyser and Kawasaki (1983)'s sense. According to these authors, some relations between features, such as the relation between backness and roundness in non-low vowels, reflect the enhancement of perceptual salience. And since it is roundness which enhances backness, the R-rule should be stated as [+back] --> [+round]. Secondly, according to Steriade, there is another class of R-rules in which a "content" feature has a defective distribution within a class of segments defined in terms of stricture features. For example, [voice] has a restricted distribution within the class of sonorants; [lateral] has a restricted distribution within the class of non-nasal sonorants and so on. Steriade also proposes that vocalic height must be considered a stricture feature so that the relation between [+high] and [+ATR], [+low] and [+back], for example, becomes similar to the relation between [sonorant] and [voice]. So she proposes that R-rules have always the

form [aF] --> [bG], where [F] is a stricture feature and [G] a content feature, or where the feature value [bG] enhances the feature value [aF]. In this way, Steriade is able to constrain the R-rules and exclude, for example, a default rule like [+round] --> [+high]. A rule like this would not be possible in her approach in the three-vowel system /a, i, u/ since the feature value [+round] occurs only in the feature bundle of the high vowel /u/. Observe that such a R-rule would claim that there could be a system in which the high vowel /u/ would behave phonologically as if its feature value [+high] were underlyingly missing, whereas the high vowel /i/ would appear to have that feature value. As Steriade notes, such a system seems not to exist.

However the constraints that Steriade poses on the R-rules do not disallow the R-rules in (32)b) with the correlated underlying specifications in (31)b). In fact, the R-rules needed in that case comply with the rule schemata proposed by Steriade since feature values like [-high] and [-low] are obviously height features, and therefore stricture type features.

There is also another point that must be clarified. In an approach like Steriade's, R-rules should not have any independent status. They should be used only to introduce underlyingly absent feature values that appear to be non-distinctive through the consideration of the structure of the segmental inventory. By imposing restrictions on R-rules, Steriade seems to imply that they have an independent status and that the R-rules actually determine the restrictions on the distribution of feature values. Furthermore, given that in many cases in

Steriade's approach there is no clear way to establish what the underlying feature values are as we have seen in the case of the three vowel system /a, i, u/, the formulation of the R-rules becomes somewhat arbitrary. And therefore, the R-rules become such a powerful tool that they can also allow wrong analyses. An example of the arbitrary use of R-rules can be seen in Steriade's analysis of Hungarian vowel harmony.

Hungarian has the vowel system in (33):

(51)	short vowels			long vowels			
	front		back	front		back	
	-rd	+rd		-rd	+rd		
	high	i	ú	u	i:	ü:	u:
	mid		ö	o	e:	ö:	o:
	low	æ[5]		ɒ			a:

/æ/ is traditionally represented as /e/ and /ɒ/ is traditionally represented as /a/.

Hungarian has a harmony rule which constrains the distribution of the feature value for [back] inside the word. Within native roots vowels may belong to either of the two sets (o(:), u (:), a(:)), (o (:), u(:)) but not to both. The vowels of a third set (e(:), i(:)) may co-occur within native roots with any vowel: /pelda/ 'example', /tömeg/ 'crowd', /bika/ 'bull', /rövid/ 'short'. The vowels of this third set are usually

called neutral vowels. Non-native roots have no restrictions on vowel co-occurrence: /buro/ 'bureau', /parfum/ 'perfume'.

Suffixal vowels agree with the backness of the last stem vowel, when this vowel is not neutral: /buro-nak/ 'bureau-DAT', /parfüm-
nek/ 'perfume-DAT'. The situation is more complex when the last stem vowel belongs to the set { e(:), i(:) } Kontra and Ringen (1986) demonstrated that stems ending in /e:/ or /i(:)/ preceded by a back vowel take suffixal back vowels: /papir-nak/ 'paper-DAT', /produktív-nak/ 'productive-DAT', /anke:t-nak/ 'meeting-DAT'. This rule holds for the majority of lexical items and for most speakers, although there are some exceptions to it. In contrast, stems like /ma:gnes/ 'magnet', which contain back vowels followed by /e/, take primarily front suffixes. Kontra and Ringen conclude, in line with Ringen's earlier findings (1978, 1980), that /e/, i.e. [æ], is not transparent with respect to the harmony rule in contemporary Hungarian, whereas /i(:)/, /e:/ are transparent to the harmony rule.

What must be explained is why there should be a disparity between the inventories of long and short neutral segments of Hungarian: why short /e/ is not neutral while long /e:/ is.

Steriade observes that " *there is an important disparity between the long and the short vowel systems of Hungarian: the low and mid short vowels are paired as to backness, with [æ] (-/e/) opposed to [ɒ] (-/a/) and [ɔ] opposed to [ɔ:], while the long vowel system has no direct back*

counterpart for the mid vowel [e:]. On the other hand, in both long and the short vowel systems, backness is non-distinctive among unrounded high vowels: neither /i/ nor /i:/ have direct back counterparts" (Steriade (1987) p. 346).

At this point, in Steriade's framework, it is possible to explain nicely why /e/, i.e. [æ], is not neutral: /e/ is paired for backness with /a/, and thus its feature value [-back] is distinctive in its feature bundle. In contrast, /e:/ has no back counterpart and therefore its feature value [-back] is non-distinctive in its feature bundle. Similarly, both long and short /i/ are neutral because they both lack a minimally different [+back] vowel.

The problem of Steriade's analysis is long /a:/. In fact, according to her procedure, the feature value [+back] of long /a:/ should be non-distinctive since there is no low front vowel /æ:/. Therefore, we would expect that the feature value [+back] be missing in the feature bundle of /a:/. Thus, /a:/ should be a neutral vowel. But this is not correct. /a:/ is a harmonic vowel. Steriade's theory cannot explain this fact. Her solution to this problem is to establish that R-rules are ordered, and that a phonological rule can apply after the application of certain R-rules but before the application of other R-rules. She can therefore propose the following analysis:

(52) Stage a: Underlying representations: all distinctive values for [back] are present. Vowel specified at this stage:
 (a, æ, o, ö, u, ü, o:, ö:, u:, ü:)

Stage b: R-rule 1: [+low] --> [+back]
 Vowels specified at this stage:
 (a, æ, o, ö, u, ü, a:, o:, ö:, u:, ü:)

Stage c: Harmony rule (iterative, feature-changing):

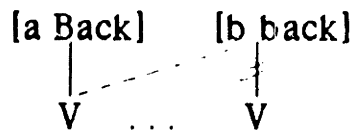

Stage d: R-rule 2: [-low, -round] --> [-back]
 (affects /i/, /i:/, /e:/)

This analysis relies on the following assumptions. First, Steriade adopts Farkas and Beddor's (1987) conclusion that [+back] and [-back] must be spread by harmony: Farkkas and Beddor show that harmony must take place both in forms like /büro:-tol/ and in forms like /parfüm-töl/. In each of these cases, the last stem vowel has a distinctive value for [back]. This distinctive feature value determines the backness of the suffixal vowels. If both distinctive [+back] and [-back] are present when harmony operates, then the harmony must be feature-changing. This conclusion was already reached earlier by Vago (1976). Secondly, Steriade follows Ringen(1980) and Kiparsky (1981) in assuming that neutralizing applications of harmony are prohibited morpheme-

internally by the Alternation/Strict Cycle Condition: this is why /buro:-töl/ becomes /büro:-tol/, rather than /*bürö:-töl/. Then, Steriade assumes that Structure Preservation prohibits harmony from affecting the default vowels. Finally, in order to account for the fact that stems consisting exclusively of neutral vowels take generally front suffixes (cf. Kontra and Ringen (1986) (experimental results)), Steriade assumes that Hungarian suffixes are specified as [-back] in the unmarked case.

Observe that Steriade's analysis is very simple and straightforward. The problem is that there is no motivation in her approach to hypothesize an ordering of the R-rules, since, according to her, they should only be an expression of the restriction on the distribution of feature values in class of segments in a segmental inventory. Steriade relies on the ordering of R-rules in order to account for the Hungarian facts. Now, if R-rules are ordered, this means that they have an autonomous status with respect to the just-mentioned restrictions. But the R-rules cannot have an autonomous status in Steriade's framework.

3. A THEORY OF UNDERSPECIFICATION BASED UPON UG FILTERS

In the preceding chapter, I argued that the structure of a segmental inventory is determined by a finite set of UG filters. Each UG filter represents the absence of a segment or class of segments in this segmental inventory. I hypothesized that the set of UG filters is hierarchically organized. The more complex a phonological segment is, the higher the filter is that excludes it in the hierarchy.

Each underlying segment in the segmental inventory of a given language violates some of these UG filters. I consider these UG filters to be underlyingly violated in that language. The UG filters that are not underlyingly violated are the underlying filters of that language. They define the segments that are underlyingly absent in that language.

In this section, I will hypothesize that the pattern of underspecification of a certain segmental inventory may be automatically derived from the set of the UG filters that are underlyingly violated in this segmental inventory. In this way, I wish to propose a theory of underspecification that encompasses the very desirable results of Steriade's theory of underspecification with all its desirable results, yet avoids the problems her theory contains.

Before introducing my theory of underspecification, it is important to make a distinction between "trivial" and "non-trivial" underspecification (cf. Steriade (1987)). In order to do so, we have to

consider an important difference between features in the feature tree. In a feature tree, we have terminal features and class features, where terminal features are always dominated by one and only one class feature. Terminal features are specified with the value plus or minus, which indicates the position of the articulator represented by the class feature that dominates them. Class features, on the other hand, are either present or absent. Now, if a class feature is underlyingly absent in the representation of a certain segment, it cannot be inserted later in the course of a phonological derivation; simply stated, the articulator that it represents is not active in the articulation of that segment. In contrast, if the value of a terminal feature is underlyingly absent in the representation of a certain segment, but the class feature that dominates it is present, then the value of the terminal feature must be specified later in the course of the phonological derivation.

I assume now that a segment is trivially unspecified for a given feature if it is underlyingly unspecified for it, and if it will not acquire a specification for it at any stage of the derivation. In contrast, a segment is non-trivially unspecified for a given feature if it is underlyingly unspecified for it, and if it must acquire a specification for that feature in the course of the derivation. This means that the underlying absence of a class feature leads to trivial underspecification, whereas the underlying absence of a terminal feature value leads to non-trivial underspecification, provided that the class feature node that dominates the terminal feature value is present. Thus, a labial is trivially underspecified for the feature [coronal], or for the feature [anterior] dominated by coronal, since the class feature coronal is

underlyingly absent in labials and cannot be inserted later in the derivation. In contrast, coronals are non-trivially underspecified for the terminal feature [anterior] since they must receive a specification for [anterior] in the course of the derivation, if they are underlyingly underspecified for it.

I assume that the theory of underspecification is concerned only with non-trivial underspecification. Therefore, in the next section, I will be concerned only with the different specifications of the values of the terminal features.

Since I will illustrate my theory with examples drawn from vowel systems, in (1) I will repeat the UG filters that I proposed in 1.1.(1) for describing vowel systems, adding two other filters to them. These filters are $*[+high]/ [+syllabic, __]$ and $*[+low]/ [+syllabic, __]$ (Recall that the context [+syllabic, ___] must be considered to represent the fact that the feature value in the filter is in a feature bundle associated with the syllabic nucleus.). The UG filter $*[+high]/ [+syllabic, __]$ was introduced to describe two-vowel systems. Here I propose another filter, $*[+low]/ [+syllabic, __]$, the only UG filter which must be underlyingly violated in two-vowel systems. I hypothesize that this filter must always be underlyingly violated. The UG filters needed to describe vowel systems are therefore those in (1):

- (1) IX) * [+low, +high]
- VIII) * [+syllabic, +nasal]
- VII) a) * [+back, -round]/ [-low, ___] b) * [+low,+ATR]
- VI) a) * [-back, +round] b) * [+high, -ATR]
- V) * [+low,+round]
- IV) * [-high, +ATR]
- III) * [+low, -back]
- II) * [-high, -low]
- I) * [+high]/ [+syllabic, ___]
- 0) * [+low]/ [+syllabic, ___]

Now I shall introduce my theory of underspecification.

First of all, I hypothesize the following principle, which I will call the Redundancy principle:

- (2) In a phonological system S, given an underlying filter * [aF, bG] in S, -bG is predictable in a feature bundle in S that contains aF.

I now propose the following principle:

- (3) Predictable feature values are underlyingly missing.^[6]

Principles (2) and (3) require that a series of feature values be underlyingly missing. They will be filled in by the following rule that I

call the Redundancy rule:

- (4) In a phonological system S, given an underlying filter *[aF, bG] in S, fill in -bG in a feature bundle in S that contains aF.

If a series of feature values is underlyingly missing, other feature values must be underlyingly present. Now, it is crucially important to establish what these underlying feature values are. I propose that the underlying feature values of a phonological system are established by considering the UG filters that are underlyingly violated in this system. I propose the following principles (The parenthesized (bG) in (5) indicates that (5) applies also in the case of filters with only one feature like (1)0 and I):

- (5) Given a phonological system S, a feature bundle in S that underlyingly violates a UG filter *[aF, (bG)] has the feature values aF, (bG) as underlying feature values.
- (6) Given a phonological system S, if the UG filter *[aF, bG] is underlyingly violated in S, a feature bundle that underlyingly contains aF, but not bG, will underlyingly contain -bG.

I shall now present a series of examples which illustrate the predictions made by my theory concerning the pattern of underspecification of different vowel systems.

Let us consider the vowel system in (7):

(7) i u
 a

This system is fully specified as in (8):

(8)	a	i	u
high	-	+	+
low	+	-	-
back	+	-	+
round	-	-	+
ATR	-	+	+

In (7), the feature bundle of /a/ violates the UG filter (1)0) and the feature bundles of /i/ and /u/ violate (1)I). Therefore according to principle (5) the feature bundle of /a/ has [+low] as an underlying feature value, and the feature bundles of /i/ and /u/ have [+high] as an underlying feature value. Principle (6) does not apply in (7) because there is no UG filter containing two features that is underlyingly violated in (7). Observe that there is no UG filter that constrains the presence of [+ and - back] and [+ and - round] in a feature bundle which contains the feature value [+high]. However, such filters do occur in the case of [+low] vowels; they are (1)III) and (1)V). Given these filters, the Redundancy principle (2), in conjunction with (3), predicts that the feature values [+back] and [-round] are underlyingly missing in

the feature bundle of the [+low] vowel. A consequence of the fact that there are no UG filters that constrain [back] and [round] in the feature bundle of the high vowels might be that we get the fully specified configurations [+high, -back, -round] and [+high, +back, +round] in the feature bundles that contains [+high]. But this would be a violation of principles (2) and (3) since the UG filters (1)VI)a) and (1)VII)a) which are underlying filters for (7) predict that one of preceding feature values must be predictable and therefore underlyingly missing. I propose that a principle independent of (4) and (5) determines what the underlying feature values are in this case:

- (9) In a phonological system S, given the feature values [a round, b back] in a feature bundle B which does not contain [+low], the feature value [a round] is underlying in B only if the UG filter *[-a round, b back], but not the UG filter *[a round, -b back], is underlyingly violated in S. Otherwise, the feature value [b back] is underlying in B.

(9) states that in a phonological system S, the feature values [+back] and [-back] are underlying feature values in feature bundles that do not contain [+low] when the UG filters (1)VI)a) and (1)VII)a) are either both underlying in S or both underlyingly violated in S. When the UG filters (1)VI)a) and (1)VII)a) are both underlying in S, we have a system which has non-low vowels like /i/ and /u/. (In the following discussion, I will consider only the case of high vowels for reasons of simplicity. However, the same points also hold for mid-vowels.) According to (9), in this system, the feature bundle of /i/ will have the underlying feature value [-back] and the feature bundle of /u/ will have the underlying feature value [+back]. When the UG filters (1)VI)a) and (1)VII)a) are both underlyingly violated, we have a vowel system that has non-low vowels like /ɪ, ʊ, ɨ, u/. According to (5), the feature

bundles of vowels /ɨ/ and /ʉ/ will have the underlying feature values [+back, -round] and [-back +round], respectively. According to (9), the feature bundles /i/ and /u/ will have the underlying feature values [-back] and [+back], respectively. Given that the UG filters (1)VI)a) and (1)VII)a) are underlyingly violated, principle (6) inserts [-round] in the feature bundle that contains only [-back], i.e., in the feature bundle of /i/ and [+round] in the feature bundle that contains only [+back], i.e., in the feature bundle of /u/. Therefore in this system, the feature bundle of /i/ will have the underlying feature values [-back] and [-round], and the feature bundle will have the underlying feature values [+back] and [+round].

In a vowel system in which the filter *[-back, +round], i.e., (1)VI)a), but not the filter *[+back, -round]/ [__, -low], i.e., (1)VII)a), is underlyingly violated, i.e., in a system which has non-low vowels like /ɨ, ʉ, u/, (9) requires that the feature bundle of /u/ has the underlying feature [+back] and that the feature bundle of /i/ has the underlying feature value [-round]. In this system, the feature bundle of /ʉ/ has the underlying feature values [-back, +round] because of (5).

In a vowel system in which the filter *[+back, -round]/[-low, __], but not the filter * [-back+, +round], is underlyingly violated, i.e., in a system which has non-low vowels like /ɨ, ɨ, u/, (9) requires that the feature bundle of /i/ has the underlying feature value [-back], and that the feature bundle of /u/ has the underlying feature value [+round]. In this system, the feature bundle of /ɨ/ has the underlying feature values [+back, -round].

At this point, the vowel system in (7) may be underlyingly specified as in (10):

(10)	a	i	u
high		+	+
low	+		
back		-	+
round			
ATR			

Given the UG filters (1)II) - IX) which are underlying filters for the vowel system in (7), the Redundancy rule (4) properly fills in the unspecified feature values in (10). In the feature bundle that contains [+low], the Redundancy rule will fill in the feature value [-high] because of the underlying filter (1) IX), [+back] because of the underlying filter (1)III), [-round] because of the underlying filter (1)V), [-ATR] because of the underlying filter (1)VII)b). In the feature bundle that contains [+high, -back], the Redundancy rule will fill in the feature value [-low] because of the underlying filter (1)IX), [-round] because of the underlying filter (1)VI)a), [+ATR] because of the underlying filter (1)VI)b). In the feature bundle that contains [+high, +back], the Redundancy rule will fill in the feature value [-low] because of the underlying filter (1)IX), [+round] because of the underlying filter (1)VII) a) [+ATR] because of the underlying filter (1)VI)b).

Let us now consider a four-vowel system like that in (11):

(11)	i	u
	æ	a

(11) is fully specified as in(12):

(12)	a	i	u	æ
high	-	+	+	-
low	+	-	-	+
back	+	-	+	-
round	-	-	+	-
ATR	-	+	+	-

In (1) the feature bundles of /a/ and /æ/ violate filter (1)0). The feature bundles of /i/ and /u/ violate the UG filter (1)I) and the feature bundle of /æ/ violates the UG filter (1)III). Therefore, according to (5), the feature bundle of /a/ has [+low] as an underlying feature value, the feature bundle of /i/ and /u/ have [+high] as an underlying feature value, and the feature bundle of /æ/ has [+low] and [-back] as underlying feature values. In the case of the feature bundle of /a/, underlying [+back] must be present according to (6) because the following two conditions are met: the UG filter (1)III) is underlyingly violated in (11), and underlying [+low] is present in the feature bundle of /a/, but not [-back]. Principle (9) determines that [+back] and [-back] are underlying feature values in the feature bundles that contain [+high], since neither filter (1)5)a) nor (1)5)b) are underlyingly violated in (11). Therefore the vowel system in (11) will be underlyingly specified as in (13):

(13)	a	i	u	æ
high		+	+	
low	+			+
back		-	+	-
round				
ATR				

Given the UG filters (1) II) and (1) IV) - IX), which are underlying filters for the vowel system in (11), the Redundancy rule will properly fill in the feature values that are unspecified in (13). The feature bundles of /i/ and /u/ will be filled in as they were in the unspecified system in (10). In the case of the feature bundle of /a/ which contains underlying [+low] and [+back], and in the case of the feature bundle of /æ/ which contains underlying [+low] and [-back], the Redundancy rule will fill in [-high] because of the underlying filter (1)IX), [-round] because of the underlying filter (1)V), [-ATR] because of the underlying filter (1)VII)b).

Let us now consider a five-vowel system like that in (14):

(14)	i	u
	ɛ	ɔ
	a	

(14) is fully specified as in (15):

(15)		a	ε	ɔ	i	u
	high	-	-	-	+	+
	low	+	-	-	-	-
	back	+	-	+	-	+
	round	-	-	+	-	+
	ATR	-	-	-	+	+

In (14), the feature bundle of /a/ violates the UG filter (1)0), the feature bundles of /i/ and /u/ violate the UG filter (1)I) and the feature bundles of /ε/ and /ɔ/ violate the UG filter (1)III). Therefore according to (5), the feature bundle of /a/ has [+low] as underlying feature value, the feature bundles of /i/ and /u/ have [+high] as underlying feature values, and the feature bundles of /ε/ and /ɔ/ have [-high] and [-low] as underlying feature values. (6) does not apply in (14) since (1)0) and (1)I) are filters with just one feature value, and since there are no feature bundles in which [-high] or [-low] occur without the other feature value contained in the violated filter *[-high, -low]. Given that neither the UG filter (1)VI)a) nor the UG filter (1)VII)a) are violated in (14), principle (9) establishes that the feature values [-back] and [+back] are underlying in the feature bundles that contain [+high] or in the feature bundles that contain [-high, -low]. Thus, the vowel system in (14) is underlyingly specified as in (16):

(16)	a	ɛ	ɔ	i	u
high	-	-	-	+	+
low	+	-	-	-	-
back	-	+	-	-	+
round					
ATR					

Given the UG filters (1) III) - IX) which are underlying filters for (14), the Redundancy rule will properly fill in the underspecified feature bundles in (16).

Let us now consider a more complicated vowel system like that in (17):

(17)	i	ü	ɨ	u
	ɛ	ø	ʌ	ɔ
			a	

(17) is fully specified as in (18):

(18)	i	ü	ɨ	u	ɛ	ø	ʌ	ɔ	a
high	+	+	+	+	-	-	-	-	-
low	-	-	-	-	-	-	-	-	+
back	-	-	+	+	-	-	+	+	+
round	-	+	-	+	-	-	-	+	-
ATR	+	+	+	+	-	-	-	-	-

In (17), the UG filters (1)0), I), II), VI)a), and VII)a) are underlyingly violated. (5) establishes that the following feature values are underlying: [+low] is underlying in the feature bundle of /a/, [+high] is underlying in the feature bundles of /i, ü, ɨ, u/, [-high, -low] are underlying in the feature bundles of /ɛ, ø, ʌ, ɔ/. [+back, -round] are underlying in the feature bundles of /ɨ, ʌ/,^[7] and [-back, +round] are underlying in the feature bundles of /ü, ø/.

Given that both (1)VI)a) and (1)VII)a) are underlyingly violated in (17), [-back] and [+back] are underlying feature values in the feature bundles of /i, e/ and /u, o/ because of principle (9). Given that the UG filter *[+back, -round]/ [-low ___] , i.e., (1)VII)a), is underlyingly violated in (17), (6) requires that [+round] is an underlying feature value in the feature bundles of /u/ and /o/ which contain [+back], but not [-round]. Given that the UG filter *[+round, -back], i.e., (1)VI)a) is underlyingly violated in (17), (6) requires that [-round] is an underlying feature value in the feature bundles of /i/ and /e/ which contain [-back] but not [+round].

Therefore the vowel system in (17) will be underlyingly specified as in (19):

(19)		i	ü	ɨ	u	ɛ	ø	ʌ	ɔ	a
	high	+	+	+	+	-	-	-	-	
	low					-	-	-	-	+
	back	-	-	+	+	-	-	+	+	
	round	-	+	-	+	-	-	-	-	+
	ATR									

Given the UG filters (1)III) , ıV), V), VI)b), VII)b)-IX), which are underlying filters for (17), the Redundancy rule will properly fill in the underspecified feature bundles in (19).

Let us now consider the vowel system in (20):

(20)	i	u
	ɨ	ʊ
	e	o
	ɛ	ɔ
		a

(20) is fully specified as in (21):

(21)		a	ɛ	ɔ	e	o	ɪ	ʊ	i	u
	high	-	-	-	-	-	+	+	+	+
	low	+	-	-	-	-	-	-	-	-
	back	+	-	+	-	+	-	+	-	+
	round	-	-	+	-	+	-	+	-	+
	ATR	-	-	-	+	+	-	-	+	+

In (21), the feature bundle of /a/ violates the UG filter (1)0), the feature bundles of /i, u, ɪ, ʊ/ violate the UG filter (1)I), and the feature bundles of /ɛ, ɔ, e, o/ violate the UG filter (1)II). The feature bundles of /e, o/ violate the UG filter (1)IV). The feature bundles of /ɪ, ʊ/ violate the UG filter (1)VI)b). Therefore, according to (5), the feature bundle of /a/ has [+low] as an underlying feature value, the feature bundles of /i, u/ have [+high] as underlying feature value, the feature bundles of /ɪ, ʊ/ have [+high, -ATR] as underlying feature values, the feature bundles of /ɛ, ɔ/ have [-high, -low] as underlying feature values and the feature bundles of /e, o/ have [-high, -low, +ATR] as underlying feature values. Given that the UG filter filter (1)VI)b) is underlyingly violated, (6) requires that [+ATR] is an underlying feature value in the feature bundles of /i/ and /u/, which have [+high], but not [-ATR]. Given that the UG filter (1)IV) is underlyingly violated (6) requires that [-ATR] is an underlying feature value in the feature bundle of /ɛ/ and /ɔ/, which have the feature value [-high], but not the feature value [+ATR]. Principle (9) then states that [+back] and [-back] are underlying in the feature bundles that contain the feature values [+high] and [-high, -low]. Therefore (20) is underlyingly specified as in (22):

(22)	a	ε	ɔ	e	o	ɪ	ʊ	i	u
high	-	-	-	-	+	+	+	+	
low	+	-	-	-	-				
back	-	+	-	+	-	+	-	+	
round									
ATR	-	-	+	+	-	-	+	+	

Given the UG filters (1)III), V), VI)a), VII)a), VIII) -IX), which are underlying filters in (18), the Redundancy rule will properly fill in the underspecified feature bundles in (22).

Given the theory that I am proposing, only positive evidence is needed to determine the underlying specifications of the segments of a given language. In fact, what is needed is to establish the underlying inventory of segments of that language. Each underlying segment of that language will violate one or more UG filters. Once we establish which UG filters are violated by each segment, principle (5) and (6) (and also (9) in case of vowel systems) determine the underlying specifications of that segment. Nothing else is needed. I believe that this affords us a highly restrictive and easily learnable theory of underspecification.

At this point, it is important to compare my theory to Steriade's. In section 2.1, I discussed the problems that arise in the approach to underspecification based on the idea that the pattern of

underspecification of a certain phonological system is motivated by considering the pattern of phonological alternations found in that system. This approach leads to a circular argument. I therefore proposed principle 2.1.(18) which disallows this kind of approach. I then observed that the superiority of Steriade's approach to underspecification lies in the fact that in her theory the pattern of underspecification of a phonological system is strictly motivated by the consideration of its structure. According to Steriade, it is the analysis of the distribution of feature values in the segments that compose a phonological inventory that determines how this system is underspecified. I argued however that Steriade's theory stipulates R-rules which do not have any status in that approach and therefore are, in part, arbitrary.

My theory shares the same basic approach as that of Steriade's: only the consideration of the structure of the phonological inventory can determine the underlying specifications of the segments of the inventory. However, no arbitrary R-rules are needed in my approach. What is important to know in my approach is which segments compose the underlying phonological inventory. In this way, the UG filters that are underlyingly violated, and consequently also the underlying filters, are established. The underlying specifications and the redundant values are then derived by the general principles (5) - (6) (and (9)) in conjunction with the Redundancy rule. No arbitrary R-rules are needed.

All of Steriade's cases can be treated straightforwardly in my approach.

Given the UG filter *[+high, +low], which is always an underlying filter, the Redundancy principle predicts that the feature value [-low] is redundant in feature bundles that contain [+high] and in particular that the feature value [-high] is redundant in feature bundles that contain [+low]. Principle (3) requires that redundant values are underlyingly unspecified. Therefore, [-low] is missing underlyingly in a feature bundle that contains [+high] and, in particular, [-high] is missing underlyingly in a feature bundle that contains [+low]. At this point, we can account for the facts of Pasiego and Ngbaka: in both of these languages the feature value [-high] appeared to be missing underlyingly in the feature bundle of the low vowels. And this is what my theory predicts.[8]

In a system where the UG filter *[+low, -back] is an underlying filter, the Redundancy rule predicts that the feature value [+back] is redundant in the feature bundle that contains the feature value (+low). Therefore, because of the Redundancy principle and principle (3) it must be underlyingly unspecified. This is the case of triangular vowel systems like Ainu and Tamil discussed by Steriade, where the lack of a front low vowels indicates that the UG filter *[+low, -back] is an underlying filter. Steriade shows that the feature value [+back] is underlyingly absent in the feature bundle of /a/ in systems like Ainu and Tamil.

In vowel systems in which the UG filters *[+back, -round] / [_____ ,

-low] and *[-back, +round] are underlying filters, that is, in vowel systems that contain only non-low vowels that are front unrounded and back rounded, principle (9) states that the feature value [-back] is underlying in the feature bundle of the front vowel and [+back] is underlying in the feature bundle of the back vowels. Given this and given the underlying filters mentioned earlier, the Redundancy rule predicts that [-round] and [+round] are redundant values in these feature bundles; in particular, [+round] is redundant, and therefore underlyingly unspecified in the feature bundle of the back vowels. This is the case of Maori, where Steriade shows that the feature value [+round] is underlyingly missing in the feature bundles of the vowels /o/ and /u/.

In vowel systems in which the UG filter *[-back, +round] is underlyingly violated, but not the UG filter *[+back, -round]/ [___ -low], that is, in systems that contain vowels like /i/, /u/ and /u/, principle (9) states that [-round] is the underlying feature value in the feature bundle of vowels like /i/ and that [+back] is the underlying feature in the feature bundle of vowels like /u/. The feature bundle of the vowel /u/ has the underlying feature values [-back, +round] because of principle (5). Given that the filter *[+back, -round][___ -low] is an underlying filter in these systems, the feature bundle of vowels like /o, u/ that contains the underlying feature value [+back] because of (9) will have [+round] as a redundant feature value. Therefore, [+round] has to be underlyingly unspecified in the feature bundles of /o/ and /u/. This is what Steriade observes in the case of vowel systems like that of

Cantonese, where back rounded vowels, but not front rounded vowels, seem to show the underlying absence of [+round].

In vowel systems like that discussed in the preceding paragraph, [-round] should be an underlying feature in the feature bundle of /i, e/. Therefore given the underlying filter *[-round, +back] / [____ -low], the Redundancy rule predicts that the feature [-back] is redundant in that feature bundle. Therefore, this feature value should be underlyingly missing. And indeed this is what we actually find in Finnish and Hungarian that have vowel systems with front rounded, front unrounded and back rounded vowels. The harmony systems of these languages shows in fact that the feature value [-back] of the front unrounded vowels /i, e/ is underlyingly missing, as we saw in Chapter 1.

In a vowel system where the UG filter *[+low, +ATR] is underlying, that is, in a system in which there is no [+ATR] low vowels, the Redundancy principle predicts that the feature value [+ATR] is redundant in the feature bundle of a low vowel. Therefore according to principle (3) it has to be underlyingly unspecified. And in fact, as Steriade observes, the feature value [+ATR] appears to be underlyingly missing in the case of vowel /a/ of Kinande, which has a vowel system with no [+ATR] low vowels.^[9]

In a consonantal system in which there are no underlying post-alveolar stops, laterals and nasals, we know that the UG filters

*[-continuant, -anterior], *[+nasal, -anterior] and *[+lateral, -anterior] are underlying filters. The Redundancy rule predicts that the feature value [-anterior] is redundant in the feature bundles of stops, nasals and laterals. According to principle (3), then, the feature value [-anterior] is unspecified in these feature bundles. This is what we find in Chumash coronal consonants /t, n, l, s, š / where the feature value [-anterior] is possible only in the feature bundle of a continuant consonant-- a fact that indicates that the UG filter *[+continuant, -anterior] is underlyingly violated-- but it is not possible in the feature bundle of stops, nasals and laterals. My theory predicts then that the coronal consonants of Chumash are underlyingly specified for the feature [anterior] as in (23):

(23)	t	n	l	s	š
	ant.			+	-

Steriade shows that an explanatory account of the sibilant harmony of Chumash where the value for [anterior] of the rightmost sibilant is spread onto the other sibilant in the word regardless of their quality requires exactly the underlying specification in (23).

In consonantal systems where *[-sonorant, +lateral] and *[+nasal, +lateral] are underlying filters, i.e. in consonantal systems that have lateral consonant only in the class of the liquids, the Redundancy principle predicts that [-lateral] is redundant in all the feature bundles containing either [-sonorant] or [+nasal]. This is what Steriade observes

in the case of Latin lateral dissimilation where a rule of dissimilation between [-lateral] segments is blocked by the presence of an intermediate non-lateral non-nasal sonorant, but not by the presence of another intermediate obstruent or nasal. My theory predicts exactly the underlying specifications required by Steriade's analysis. Taking in consideration only the coronal segments, these in fact are the underlying specifications predicted by my theory:

(24)	d	s	n	r	l
	later			-	+

[+lateral] is an underlying feature value in the feature bundle of /l/ because in this feature bundle the UG filter *[+sonorant, +lateral] / [____, -nasal] is violated. [-lateral] is an underlying feature value in the case of the feature bundle of /r/ because the UG filter *[+sonorant, +lateral] / [____, -nasal] is violated in the system in (24), and [+sonorant] is contained in its feature bundle, but not [+lateral]. The feature value [-lateral] is unspecified in the feature bundles of /d/, /n/ and /s/ as the Redundancy principle and principle (3) predict given that the UG filters *[-sonorant, +lateral] and *[-nasal, +lateral] are underlying in this consonantal system.

In consonantal systems where the UG filter *[+sonorant, -voice] is underlying, that is, in which no voiceless sonorants are present, the Redundancy principle predicts that the feature value [+voice] is redundant in the case of sonorants. This is shown by Ito and Mester (1986) in the case of Japanese where sonorants do not trigger a rule

that blocks voiced obstruents in the same word. This can be explained if they do not have an underlying specification for [voice] and this rule is triggered only by underlying specification for the feature [voice]. And this is precisely what my theory also predicts.

Observe that both Steriade's theory and mine share the same intuition that what is important in determining the unspecification of a feature value is whether or not a certain feature value is used distinctively or not in a feature bundle: if it is distinctive, it is underlying; if it is not, it is underlyingly absent. But there is a crucial difference. According to Steriade, this is the primitive on which the theory is based. According to me, instead, the distinctiveness or nondistinctiveness of a feature value in a certain feature bundle in a certain phonological system depends of the UG filters which are underlying in that system. It is possible to see the difference very well by comparing Steriade's analysis of Hungarian with what would be my analysis of it.

I would propose the following analysis: let us consider the vowel system of Hungarian again:

(24)	short vowels			long vowels		
	front		back	front		back
	-rd	+rd		-rd	+rd	
high	i	ü	u	i:	ü:	u:
mid		ö	o	e:	ö:	o:
low	æ		ɒ			a:

Since Steriade's underspecification theory is based only on the consideration of distinctive of nondistinctive assignments of feature values in phonological systems, in the case of (24) she is forced to say that the feature value [+back] is non-distinctive in the feature bundle of /a:/ since there is no distinctive contrast between front and back low vowels in the long vowel series. Therefore she must postulate that the feature value [+back] in long low vowels is underlyingly absent and that there is a R-rule that fills in [+back] in the feature bundle of /a:/. The problem with her analysis is that the feature value [+back] of the long /a:/ does not behave like an unspecified value in the vowel harmony system of Hungarian. So she must postulate that the R-rule that supplies [+back] in /a:/ applies before the vowel harmony rule applies. But this ordering of R-rules is completely ad hoc. There is no independent reason in Steriade's approach that supports its postulation, other than that of accounting for behavior of long /a:/. The postulation of an ordering of R-rules is therefore arbitrary.

My theory imposes a different solution. In my approach, what is important in determining underlying specifications of features of a

segmental inventory I is the consideration of which UG filters are underlyingly violated in I. Now the distinction in length does not play any role in the UG filters that are proposed to account for the various segments that can occur in vowel systems. Distinctions in length are probably ruled by conditions on syllabic structure and not by constraints on feature cooccurrence. Therefore the distinction between long and short vowels of the Hungarian vowel system is not important in determining what UG filters are underlyingly violated in that system. We establish what UG filters are violated simply by considering what are the feature bundles of the segments in the inventory, independently of their length. Now what are the UG filters that are violated in (24)?: The feature bundle of /a/ violates (1)0), the feature bundle of /æ/ violates (1)0) and (1)III), those of /e/ and /o/ violate (1)II), that of /ü/ violates (1)I) and (1)VI)a), that of /ö/ violates (1)II) and VI)a), those of /i/ and /u/ violate (1)I). Therefore, according to (5), the feature bundle of /a/ contains [+low] as underlying feature; the feature bundle of /æ/ [+low, -back]; those of /e/, /o/ [-high, -low]; that of /ü/ [+high, -back, +round]; that of /ö/ [-high, -low, -back, +round]; those of /i/ and /u/ [+high]. Given that the filter *[-back, +low] is underlyingly violated in Hungarian, Principle (6) requires that the feature value [+back] be underlyingly present in the feature bundle of /a/, which contains [+low] but not [-back]. Finally, principle (9) establishes that the feature bundle of /i/, /e/ must contain underlying [-round] and the feature bundle of /u/ /o/ underlying [+back]. This is a consequence of the fact that the UG filter *[-back, +round] is underlyingly violated, but not the UG filter *[+back,

-rd)/[____, -low].

The feature bundles of the vowels composing the Hungarian vowel system are therefore underlyingly specified as in (25):

(25)	a	æ	e	o	ö	ü	i	u
high			-	-	-	+	+	+
low	+	+	-	-	-			
back	+	-		+	-	-		+
round			-		+	+	-	
ATR								

Therefore, my theory requires correctly that /a/ is underlyingly specified as [+back]. In contrast, Steriade's theory requires that the feature value [+back] is non-distinctive and therefore underlyingly missing. And this is incorrect.

At this point, I have to address a problem that my theory encounters. I am assuming that the underlying inventory of a phonological system with its underlying specifications is a result of the process of determining what UG filters are underlyingly violated in this phonological system, and therefore of determining what UG filters are underlying filters of this phonological system. This process determines what segments must be considered as underlying in a phonological system independently of their prosodic quantities. This leads to a problem in the case of Hungarian, where we have two vowel series

differentiated by length. In fact, my procedure would lead one to assume that the same set of vowels should be present in the two series. But as a matter of fact, this is not what we find: certain segments that should be expected in both series are actually missing in one of the series: /e/ is missing in the series of the short vowels and /æ:/ is missing in the series of the long vowels. This situation is brought about by diachronical changes that affected the vowel series and created asymmetries that cannot be accounted for by the UG filters. In Chapter 3, I will propose that such situations must be dealt with by postulating auxiliary filters. Therefore, I propose that the two following auxiliary filters must be postulated for the Hungarian vowel system:

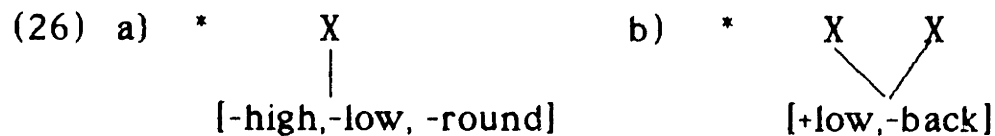

(26) a) and b) states that in Hungarian vowel inventory short front mid vowels and long low front vowels do not occur. Auxiliary filters do not play any role in the underspecification theory, since I assume that it is based only on the consideration of UG filters. Auxiliary filters represent segments whose absence is accidental, and therefore, I assume, devoid of phonological relevance. The consequence is that the presence of the auxiliary filters (26) a) and b) does not interfere with the underlying assignments in (25).[10]

In this way, a straightforward account of Hungarian vowel

harmony is possible. The vowel harmony rule is like that proposed by Steriade: an iterative feature changing harmony rule which applies to representations containing only underlying features:

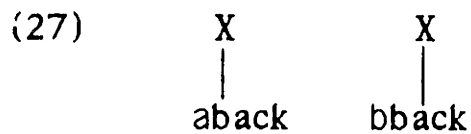

Of course, as in Steriade's model, the rule cannot apply morpheme-internally by the strict cycle.

The vowels /i(:)/ and /e:/ do not have an underlying feature value for [back] as you can see from (25). Therefore, according to principle 6.(1) of Chapter 1, the harmony rule cannot apply to them if it spreads the feature value [+back]. In fact, this principle states that the application of a phonological rule to a feature bundle cannot fill an unspecified value with a value that is blocked by a filter in that feature bundle. Given the underlying filter [-round, +back]/[-low, ____], this is what happens with the feature bundles of /i/ and /e/. Therefore, if the harmony rule spreads [+back], it cannot be applied to them. However given that no value for [back] is present in their feature bundles, when the harmony rule applies, /i(:)/ and /e:/ will be transparent to it. If the harmony rule spreads the feature value [-back], the harmony rule can apply to the feature bundles of /i/ and /e/. Once it is applied, /i/ and /e/ will be possible triggers of it and can spread the value [+back] to the following vowel. In this way, the neutrality of these vowels with respect to the harmony rule is accounted for.

All the other vowels of Hungarian are instead underlyingly specified for [back] according to (25). In particular /æ/ is [-back] and /a:/ is [+back]. Therefore they will all behave as harmonic vowels.

It is possible to see the effect of the presence of the auxiliary filter (26)b) by considering the harmonic alternations of the suffixes that contain the long low vowel /a/, for example, the suffix na:l /ne:l/. In fact, in the case of the alternants of these suffixes that we find in harmonic contexts with front vowels, we do not have the low front vowel that we should expect, but instead we have a long mid front vowel. Thus, we do not find /næ:l/, but we find /ne:l/ with a stem that contains front vowels. The harmony rule should have applied as in (28) in this case:

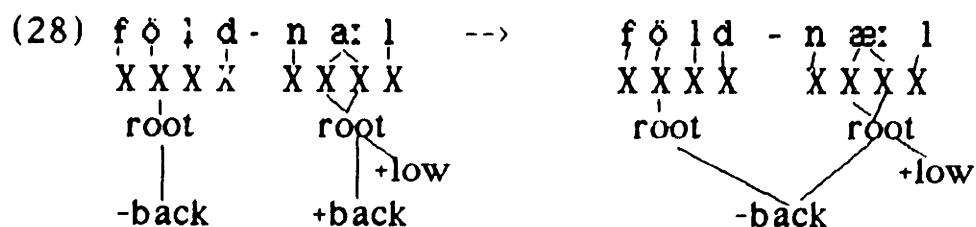

But the result that we obtain in (28) is not the correct result, since we obtain /földne:l/ from /föld-næ~l/, rather than /földnæ:l/. I can explain this by saying that when the harmony rule produces a configuration in violation of (26)b), the auxiliary filter triggers the application of a clean-up rule in order to repair this violation. I suppose that the clean up rule that applies in this case is delinking of [+low]. Therefore, we obtain the configuration in (29) through the application of delinking of [+low].

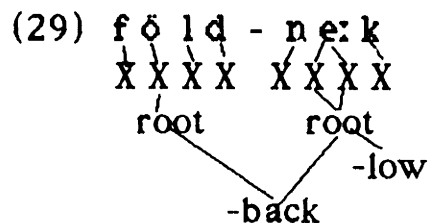

Observe that the auxiliary filter (26)b) does not block the application of the harmony rule as the the underlying UG filter * $[+back, -round]/ [___ , -low]$ does. The difference is in the fact that auxiliary filters do not play any role in establishing the pattern of underspecification in phonological systems, whereas underlying UG filters do. In particular, the underlying filter * $[+back, -round]/ [___ -low]$ in conjunction with principle (9) establishes that the feature value $[-back]$ is redundant in a feature bundle that contains the feature value $[-round]$. Remember that the harmony rule is prevented from applying to the feature bundles of $/i(:)/$ and $/e:/$, precisely because the value for $[back]$ in these feature bundles is redundant, and therefore unspecified, and according to principle 6.(1) of Chapter 1, a rule cannot assign to an unspecified feature a value that would create a violation of an underlying filter. The auxiliary filter (26)b) instead does not affect the underlying specifications of the feature bundle of $/a:/$ in any way. Therefore, the harmony rule can apply to it without being blocked by principle 6.(1) of Chapter 1.

Observe that it is not possible to replace (26)b) with a language-specific rule like (31): (I will discuss (26)a) in note 10)

(31) [+low, -back] --> [-low, -back]/

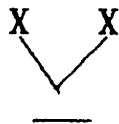

In fact, if we supposed a rule like (31), we would have to assume that there is an underlying long /æ:/. Now this long /æ:/ would be a harmonic vowel as its short counterpart. Therefore, we should expect that certain instances of long e, precisely those derived from long /æ:/, (31) should trigger the harmony rule. But this is not correct. Long /e:/ is always neutral. Therefore, the correct approach is to assume (26)b) that states that there is no underlying long /æ:/.

Observe that I am supposing that /na:l/ is the underlying form for this suffix. Only by supposing that, can I explain the alternation in height of the vowel of the suffix. This, however, goes against Steriade's hypothesis that Hungarian suffixes are underlyingly specified as [-back]. Steriade hypothesizes this in order to explain the fact that suffixes are specified as [-back] when they occur with roots that contains only neutral vowels. I hypothesize instead that suffixes can also be underlyingly specified as [+back], for example in the case of /-na:l/. I have the problem then to explain why a suffix like /-na:l/ occurs in its front form after root with neutral vowels as you can see in (31):

(31)	vɪ:z	'water'	vɪ:z-ne:l
	ve:r	'blood'	ve:r-ne:l

I will suppose that roots that contain only neutral vowels must be assigned a diacritic floating value for the feature [back]. It is this floating feature value that triggers the harmony rule. Thus the stems /vi:z/ and /ve:r/, for example, are assigned the feature value [-back]. Observe that floating feature values must be supposed in Hungarian since there is a set of fifty roots containing only neutral vowels that require back suffixes, as in the following example:

- (31) hi:d 'bridge' hi:d-nak hi:d-na:l hi:d-tol
 ce:l 'goal' ce:l-nak ce:l-na:l ce:l-tol

In Chapter 3, when I will discuss the status of the auxiliary filters in my theory, another case will be provided that supports my theory of underspecification against that of Steriade's. It is the case of Russian voicing. Russian voicing shows the following: the sonorants, which are predicted to be underlyingly unspecified for the feature [voice] by the underlying filters of this language, are neutral and transparent to the voicing rule, as expected. In contrast, the voiceless affricates and velar continuants, which according to the underlying filters of this language cannot be underlyingly unspecified for the feature [voice], may be the trigger and target of the voicing rule, even if their voicing is non-distinctive in the consonantal system of Russian, given that they lack voiced counterparts in the underlying inventory. According to Steriade's theory, the latter segments should be underlyingly unspecified for the feature [voice]. In fact, her theory establishes that a feature value is unspecified in a feature bundle if it is not distinctive in that feature bundle. This is precisely the case of affricates and velar

continuants in Russian, which are always voiceless in the underlying inventory.

4. UNDERLYINGLY ABSENT DISTINCTIVE VALUES

Let us now consider a different point. As we have seen, Steriade (1987) proposes a distinction between non-distinctive values and distinctive values of features. A feature has a non-distinctive value in a feature bundle if only one value of this feature is possible in this feature bundle. There is overwhelming evidence that non-distinctive feature values are underlyingly missing. A feature has a distinctive value in a feature bundle if the opposite value of this feature is also possible in an identical feature bundle. Steriade shows that there is some evidence that both distinctive values of a feature are underlyingly present: this was the case of Ngbaka and Tamil, for example. However, she observes that there are a few cases in which there is compelling evidence that one of the distinctive values is underlyingly missing. The theory that I have developed up to this point can account for all Steriade's cases of underlyingly missing redundant feature values. But it cannot admit any other underlyingly missing value that is not a redundant value. Therefore, I will now consider the evidence for underlyingly missing complement feature values and I will propose an improvement of my theory.

One of the phenomena that Steriade discusses as evidence for the hypothesis that one of the complement feature values is underlyingly unspecified is Lyman's Law of Japanese that I discussed earlier.

Remember that Lyman's Law is a rule that prevents two feature values [+voice] from appearing in the same stem. Following Ito and Mester (1986), she argues that a test can be built for determining whether a segment is underlyingly specified for [voice]. The test is the following: If a segment is underlyingly specified for [voice], it will trigger and/or block Lyman's Law'. If instead a segment is not underlyingly specified for [voice], it will be transparent to it. We have seen that sonorants are transparent to Lyman's law. This is something we expect since [+voice] is a redundant feature value in a feature bundle that contains the feature value [+sonorant]. However, the same test shows that the feature value [-voice] is underlyingly unspecified. In fact an intervening voiceless obstruent does not block the application of Lyman's Law, as you can see in the following example: (remember that Rendaku is a rule that voices a word-initial obstruent in a second member of a compound):

- (1) /onna kotoba/'feminine speech' -->(Rendaku-->
 /onna gotoba/ --> (Lyman's Law)--> /onna kotoba/

The last step of the derivation in (1) must be represented as in (2):

- (2) / o n n a g o t o b a / --> / o n n a k o t o b a /
 | | |
 [+voice] [+voice] [+voice]

Observe that the presence of the voiceless /t/ between the voiced /g/ and /b/ did not prevent the application of Lyman's law. Therefore, it must be supposed that the feature value is underlyingly absent and that it is introduced by the D-rule in (3);

(3) [] --> [-voice]

Thus, we have to hypothesize that in Japanese only one of the distinctive values for [voice] is underlyingly specified, i.e., [+voice], and that the other one is introduced by the rule in (3).

In this way Lyman's Law can be represented as a rule that deletes a feature value [+voice] when it occurs in a stem that contains another feature value [+voice]. The unspecified feature bundle that we obtain in this way will be then filled by (3) together with all the other feature bundles that are instead underlyingly unspecified.

An analysis like that just proposed is not possible in the theory that I developed up to this point since according to it, all non-redundant feature values are underlyingly specified, and therefore there cannot be any stage in which a "distinctive" value is underlyingly missing. A possible proposal could be to hypothesize that principles 2.3.(5) and 2.3.(6) apply at two different stages of the derivation, and to allow applications of phonological rules between them. The consequence of this would be that there could be rules that would be sensitive to the presence of features resulting from the violations of UG filters, but not to other feature values, and in particular, not to feature values determined by principle 2.3.(6). This could be very plausible if we suppose that feature values that are underlyingly secondary to violation of UG filters are in some sense marked in comparison to feature values which are underlyingly secondary to principle 2.3.(6).

The latter feature values are in fact previous redundant values that are not redundant any more because the UG filter that made them predictable is violated. The case of Japanese could thus be analyzed in this way: In a phonological system like that of Japanese in which voiced obstruents are present, the UG filters: *[-continuant, +voice] and * [+continuant, +voice] / [____, -sonorant] are underlyingly violated.^[11] Therefore according to rule 2.3.(5) the feature bundle of voiced obstruents must be underlyingly specified for [+voice], besides [-] or [+] [continuant. I could then hypothesize that Rendaku and Lyman's Law apply at this stage before rule 2.3.(6) specifies the feature value [-voice] in the feature bundles of the other obstruents. All the facts of this phenomenon would then be accounted for.

However, observe that if I am right in what I am proposing, we should expect to find phonological rules that are sensitive only to the distinctive values of a feature that are introduced by principle 2.3.(5), but not to the distinctive values of the same feature that are introduced by principle 2.3.(6). Consider, for example, a vowel system that is composed of the vowels / i, ɪ, e, ε, a, ɔ, o, ʊ, u /. In this system the configurations [+high -ATR], [-high +ATR] are underlying because of the underlying violations of the UG filters * [+high, -ATR], * [-high +ATR]. If I were right in my proposal, we should expect that in this system there could be a rule that is sensitive to the values [+ATR] of the configuration [-high +ATR] and to the value [-ATR] of the configuration [+high -ATR], but not to the value of [+ATR] of the configuration [+high +ATR] or the value [-ATR] of the configuration [-high -ATR], since the

former values are introduced by principle 2.3.(5) and the latter by principle 2.3.(6).

I do not know of any such system. Therefore, I conclude that my proposal to make it possible for a rule to apply between principles 2.3.(5) and 2.3.(6) is not correct and that the two principles 2.3.(5) and 2.3.(6), as well as 2.3.(9) apply simultaneously. They are part of a component that defines what the underlying features of the vowels are, independently of the phonological rules. Therefore, we need a different solution for cases like that of Japanese.

Observe that the peculiarity of cases like that of Japanese is that a rule is sensitive to an underlying value of a feature, but not to its opposite. This is what is captured by assuming that a certain value of a feature is underlying, but not its distinctive value. As we have seen, this solution is not possible in my approach where there is no difference between underlying and distinctive values because of the way in which underspecification is determined. I believe, however, that there is something correct in the difference between underlying and distinctive values. To capture this difference in my framework, I will propose that UG provides the following parametrical rule. By proposing that it is parametrical, I hypothesize that certain languages can adopt it as a parameter, whereas others do not:

- (4) Given aF and -aF in the underlying representations of a morpheme, simplify the representations by assuming
[] --> [-aF]

(4) is a rule that simplifies the structural complexity of the representation of morphemes. It states that certain values are predictable in representation of a morpheme. Therefore, by principles 2.3.(3) and 2.3.(4), they are missing, and the rule defined by 2.3.(5) will act as a feature filling rule. Observe that principle 2.3.(5) does not affect the underlying specifications of the segment that are as defined by the principles 2.3.(5)-(6) and principle (9), but just the representation of morphemes. This means that the underlying representation of a segment in a morpheme is the underlying configuration defined by 2.3.(5)-(6) and (9) less the feature values defined by (4). Observe that improper applications of the rules defined by (4) will be blocked by principle 6.(1) of Chapter 1 that says that unspecified feature value in a given feature bundle cannot be filled in with a value disallowed by an underlying filter in this feature bundle.

Given a morpheme that has an underlying representation like that in (5):

$$(5) \quad \begin{array}{cc} [\dots X \dots X \dots] \\ | \quad | \\ +F \quad -F \end{array}$$

if rule (4) is active in the language to which the morpheme belongs, the morpheme will be simplified as in (6) where + is chosen as the basic value:

$$(6) \quad [\dots X \dots X \dots]$$

$$\quad \quad \quad |$$

$$\quad \quad \quad +F$$

What is the value that must be considered as underlying in the morphemes? I do not have any suggestions concerning this point. I will assume that it is a matter of language specific choice, even if in the examples that I will discuss it seems that it is always the value [+] to be underlying and the value [-] to be missing by (4).

Given that there are only few cases that can be analyzed by supposing the phonological presence of a feature value, but not of its opposite. I will hypothesize that rule (4) is very marked so that its presence in the grammar is very costly. Therefore, only few languages will adopt it. For example, I hypothesize that rule (4) is not parametrically adopted in Tamil, Ngbaka and Chumash.

Let's consider Japanese. Given the presence of voiceless stops and continuant, we know that the UG filters *[-continuant, +voice] and *[+continuant, +voice] / [___ -sonorant] are underlyingly violated. Therefore, according to (4) and (5) we should have the following underlying specifications for these segments:

(7)

voiceless stops	voiced stops	voiceless cont.	voiced cont
-cont	-cont	+cont	+cont
-voice	+voice	-voice	+voice

However, I assume that in Japanese rule (4) applies to simplify the

harmony rule which propagates stem [back] values onto suffixal vowels is not triggered or blocked by these vowels:

(11) a) talo-ssa 'house-inessive' mykä-ssä 'mute-inessive'

b) lune-ssa 'snow-inessive' lase-i-ssa 'glass-plur-iness.'

c) Pariisi-ssa 'Paris-inessive' Bysanti-ssa 'Byzantium-iness.'

As in the case of Hungarian, the behavior of the neutral vowels is accounted for by the presence of the underlying filter *[+back, -round] /[____, -low], which makes the values [-back] redundant in the cases of the feature bundles of /i/ and /e/. Principle 6.(1) of Chapter 1 then blocks the application of the harmony rule to these vowels because a configuration of features disallowed by an underlying filter would be created if the feature value [+back] spread by the harmony rule fills in their unspecified value for back. Then given that they do not have any specified value for [back], they will be also transparent to the harmony rule.

Native stems are generally harmonic: their non-neutral vowels are either all back or all front. Loanwords may be disharmonic, mixing freely the vowels of the two sets:

(12) a) marttyri 'martyr', jonglööri 'juggler', analyysi 'analysis'

b) syntaksi 'syntax', tyranni 'tyrant', dōsa 'bus',

följetongi 'feuilleton'

Disharmonic stems have a different harmonic behavior depending on whether the last non-neutral vowel of the stem is back or front. If it is front, the disharmonic stem can take either a back suffix or a front suffix: both the following forms are considered possible in Finnish:

(13) a) analyysi-a

b) analyysi-ä

Campbell (1980) observes, however, that there is a difference of style between the two forms in (13): (13)a) is considered as belonging to a more prestigious, more learned style; (13)b) instead belongs to a more colloquial style.

In contrast, if the last non-neutral vowel of the disharmonic stem is back, the disharmonic stems take always back suffixes:

(14) tyranni-ko , följetongi-a

They cannot have front suffixes independently of the style in which these forms are used:

(15) * tyranni-kö , * följetongi-ä

The problem is then to explain the different patterns of harmonic behavior of the suffixes with the disharmonic stems: the prestigious

/analyysi-a/ and the colloquial /analyysi-ä/ seem to be differentiated by the fact that the vowel /y/ in the prestigious style behaves as a non-neutral harmonic vowel, whereas the vowel /y/ in the colloquial style behaves as a neutral vowel. How is it possible to explain this fact? Steriade (1987), following Kiparsky (1981), proposes that the front vowels in the colloquial style are not specified with the feature [-back] in the same way as the neutral vowels are not underlyingly specified with the same feature. I will adopt the same proposal and modify it in my framework.

I will propose the following. Given the UG filters that are underlyingly violated in the case of the Finnish vowel system, principles 2.3.(5), 2.3.(6) and 2.3.(9) establish that the vocalic segments of Finnish have the following underlying specification:

(16)	i	e	ü	ö	æ	a	o	u
high	+	-	+	-			-	+
low		-		-	+	+	-	
back			-	-	-	+	+	+
round	-	-	+	+				
ATR								

I assume that rule (4) applies in the representation of morphemes in Finnish (in the formal style). Assuming that only [+] values are underlying, (16) will be simplified as in (17):

(17)a)	i	e	ü	ö	æ	a	o	u
high	+		+					+
low					+	+		
back						+	+	+
round			+	+				
ATR								

For (17) we need the following rules determined by (4) to fill in the feature bundles:

- (17)b)
- a) [] --> [-high]
 - b) [] --> [-low]
 - c) [] --> [-back]
 - d) [] --> [-round]

At this point, my analysis is identical to that of Steriade. The vowel harmony rule applies at underlying representations and spreads the feature [+back] to unspecified target. It does not apply to morpheme internally because of the strict cycle.

The behavior of disharmonic roots in the formal style is easily accounted for. The feature [-back] will be underlyingly missing in morphemes. Therefore, at this stage, the form /analyysi-a/ will be as in (18):

(18) a n a l y y si - A
 | |
 +back +back

Therefore, the [+back] feature can spread to the suffix without any problem:

(19) a n a l y si - a
 | |
 +back +back

I hypothesize that rule (4) does not apply in the colloquial style. Therefore, the underlying representation of the morphemes will have the underlying specification determined by principle 2.3.(5)-(5) and principle (9) that we see in (16). Therefore, a form like /analyysi-ä/ must be crucially represented as in (20):

(20) a n a l y si - A
 | | |
 +back +back -back

Therefore, the harmony rule cannot be triggered any more by the feature [+back], which is no longer the last harmonic feature of the root. In (20) [-back] is the last harmonic feature of the root, and it will be this feature that will be spread onto the suffixal vowel.

(21) a n a l y si - ä
 | | |
 +back +back -back

if a phonological rule is sensitive to a given redundant value, it must then also be sensitive to the other redundant values.

I know of only one possible exception to this claim. In Japanese, there is a rule that voices an obstruent when it immediately follows a nasal within the domain of a simple word (cf. Ito and Mester (1986)). Consider the gerundive that is formed by adding the suffix /-te/. Given this rule, the gerundive forms of /kam/ 'chew' and /šin/ 'die' are *kande* and *šinde*, not **kante* and **šinte*. This reflects a constraint on Japanese native morphemes that requires voicing agreement in nasal + consonant clusters, e.g., *tombo* 'dragonfly', *kambašii* 'fragrant', *šindoi* 'tired', *unzari* 'disgusted', *kanjōe* 'thought,' but not *mp, *nt, *ns, *nk.

This rule of post-nasal voicing is restricted to early levels of the morphology and applies morpheme-internally and to primary affixes. This rule does not apply in Sino-Japanese compounds, e.g., *sam + po*, **sam + bq* 'stroll, *han + tai*, **han + dai*, 'opposition,' or in Yamato compounds, e.g., *hyootan + kago*, **hyootan + gago*, where its effect would only be observable when Rendaku is blocked by Lyman's Law (cf. Ito and Mester (1986); see also the description of Japanese in the preceding section). Now Ito and Mester (1986) argue that this rule of post-nasal voicing should be subsumed under another rule that must be postulated in the Japanese phonology: the rule of voicing spread represented in (1):

(1) [+voice]
 |
 X X

Rule (1) is needed to account for the fact that after a voiced obstruent, a voiceless consonant is voiced, as is seen in the gerundive form of the stem /tog/ 'sharpen':

(2) tog + te --> tog de

The form /tog de/ is then changed into /toi de/ by an independent rule of velar vocalization.

If the rule of post-nasal voicing is subsumed under (1), we have the problem that all of the other sonorants, /r/ and /w/ and vowels, do not trigger it. In order to solve this problem, Ito and Mester propose that the redundant value [+voice] of nasal is specified before the rule (1) applies, whereas the redundant value [+voice] of the other sonorants is specified later. In this way, we would obtain the situation that is prohibited by the theory of underspecification I am proposing, in which there is only one Redundancy rule.

However, even if the attempt to subsume the rule of post-nasal voicing under (1) is desirable, given the simplification of the grammar that would result in this way, it faces serious problems.

Observe that in the preceding section we have seen that in Japanese, sonorants including nasal must be unspecified for the feature

[+voice] when the Rendako rule applies in compounds. Only in this way can we explain why Lyman's Law does not apply when a sonorant is present in the second member of a compound. If a voiced obstruent was instead there, Lyman's Law must apply:

- (3) a) /garasu tana/ 'glass shelf' --> garasu dana (by Rendaku).
b) /kami kaze/ 'divine wind' --> kami gaze (by Rendaku) --> kami kaze (by Lyman's law).

We are then forced to say that the morphological level of compounding precedes the morphological level of verbal affixation. At the level of compounding the redundant value [+voice] is not present in words, therefore they cannot trigger (1) together with the other nasals. At the level of verbal affixation, the redundant feature [+voice] is specified in nasals and therefore they can trigger (1). The problem is then why (1) does not apply in at this level. Ito and Mester (1986) propose that it is because of the strict cycle: the feature value [-voice] is present at this stage and therefore (1) is feature-changing. Thus it cannot apply in a compound like /hyootan-kago/ because it is an underived environment at this stage. But if this is correct, as Ito and Mester (1986) also note, we can no longer explain why there voicing agreement in nasal + consonant cluster inside morphemes, since (1) cannot apply morpheme-internally at this stage because of the strict-cycle.

Observe then that there is a rule of nasal assimilation in Japanese. We can see the effect of this rule in the already-mentioned gerundive form of the root /kam/, that is, *kande*, and in the already-mentioned morpheme-internal clusters /mb/, /nd/, /nz/, /ŋg/. Observe that this rule of nasal assimilation does not apply in compounds, as we can see in the compound *hyootan-kago* 'gourd basket'. Observe that the fact that this rule of nasal assimilation applies morpheme-internally and in verbal affixation, but not in compounding seems to indicate that the boundary between affixes and verbal root is somewhat weaker than the boundary between compounds. This runs counter to the preceding assumption that the level of compounding precedes the level of verbal affixation.

Note now that post-nasal voicing seems to be a phenomenon different from voicing assimilation, contrary to what (1) would indicate. Herbert (1986) observes in fact that post-nasal voicing is "perhaps the most common process to apply to the oral consonant given a series of phonetic reasons to explain it." We can therefore guess that it can apply in languages that do not have voicing assimilation. This is probably the case of Malayalam (cf. Mohanan and Mohanan (1981) where we have a rule of post-nasal voicing, but we cannot assume that it is an instance of a more general rule of voicing assimilation. It would then be incorrect to subsume it under voicing assimilation since we would miss the peculiarity of this phenomenon. Therefore, I propose that post-nasal voicing in Japanese cannot be treated as an instance of rule (1).

Observe now that in Japanese post-nasal voicing is always correlated with nasal assimilation, as is possible to see by comparing the case of verbal affixations where there is post-nasal voicing and nasal assimilation with the case of compounding, where there are neither post-nasal voicing nor nasal assimilation. I therefore hypothesize that post-word voicing is dependent on nasal assimilation, and I propose the following rule:

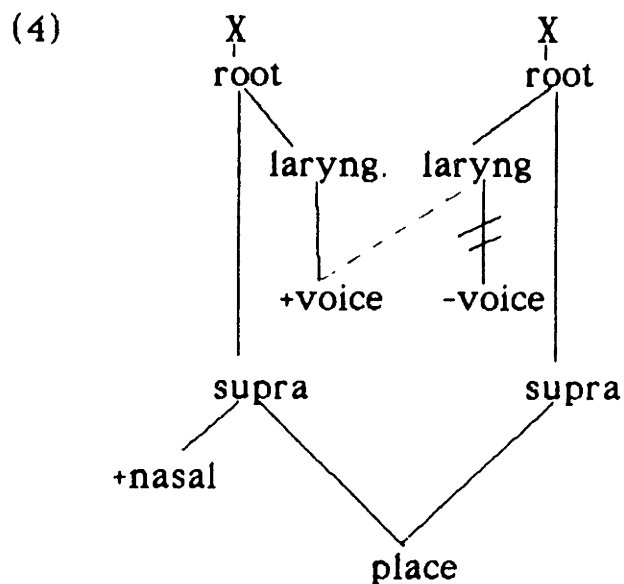

I propose that (4) applies after all the redundant values are specified by the Redundancy rule. Therefore, Japanese post-nasal voicing does not represent a counterexample to my claim that all redundant values are specified simultaneously by the redundancy rule.

FOOTNOTES CHAPTER 2

1. Even if there is the default rule (i) provided by UG, the only consideration that would lead Archangeli and Pulleyblank to establish that [+ATR] is unspecified in a feature bundle that contains [+high] is the fact that rule (8) is not triggered by /i/.

(i) [+high] --> [+ATR]

2. Observe the following: even if there are more rules that motivate the same unspecified status of a feature value or a set of feature values, we do not escape the vicious circle. In fact, given rule 1, rule 2, rule 3, rule 4 in Archangeli and Pulleyblank's approach, the unspecified status of a feature value would be motivated as follows:

The feature value aF is unspecified because rule 1, rule 2, rule 3, .. rule n, have the property of not seeing it.

The point is then that rules 1, 2, 3, .. n, have the property of not seeing the feature value aF because this feature value is unspecified. We would therefore have the same vicious circle that we would have when there is just one rule that motivates it. As before, this means that the unspecified status of a feature value cannot be verified in Archangeli and Pulleyblank's framework, but only postulated.

3. In Section 1.1, I argued that Structure Preservation is not a correct principle. This fact does not have any consequence for Steriade's argument. See note 8 from my account of the same fact.

4. See Note 9 for my account of the same fact.

5. I represent the low front vowel of Hungarian with the symbol æ. In the literature (see Vago (1976), (1980), Ringen (1980), Steriade (1987)) the symbol ɛ is used to represent the same sound.

6. In S-Chukchi (see 1.8), I have argued that feature values [+ATR] of high vowels and [-ATR] of low vowels are underlyingly specified, although they are redundant, and therefore predictable in the feature bundles of those vowels. Therefore, principle (4) should be relaxed to allow cases like that of S-Chukchi and instead (i) should be proposed:

- (i) Predictable feature values tend to be underlyingly missing.

7. I assume that the features in the context of a UG filter do not become underlying features by (5) when this filter is violated. This is the case for example of (1) VII)a); the context of this UG filter simply indicates that the filter does not apply in the case of low vowels, where the configuration [+back, -round] is possible. Observe that we need the context /[____-low] in the UG filter (1)VII)a) to have the proper filling in of [-round] in the feature bundle of /a/ in the vowel system in (11), which underlyingly contains both [+low] and [+back]. If there were no context in the case of (1)VII)a), the Redundancy rule would fill in that feature bundle with [+round]. And this is a wrong result.

It could be that the UG filter (1)VII)a) is wrong and that it should actually be divided into two different UG filters: (i) *[+back, -round, +high] and (ii) *[+back, -round, -high, -low], since the vowels /ɨ/ and /ʌ/ that are possible in violation of (i) and (ii), respectively, seem to have different degrees of markedness.

8. The fact that in Pasiego /a/ behaves as a neutral transparent vowel is explained in the following way: the fact that /a/ is not affected by the height harmony rule is accounted for by principle 1.6.(1). Recall that principle 1.6.(1) blocks the application of a rule to a feature bundle if this rule cannot fill a feature unspecified in this feature bundle with a value that would create a disallowed configuration in this feature bundle. This is what would happen in the case of /a/ in Pasiego if the height harmony rule spreads the feature [+high] onto it. In fact, this feature value would create the disallowed configuration [+low, +high]. Therefore, if the rule spreads [+high], its application to the feature bundle of /a/ is blocked. If the rule spreads [-high], the rule can apply to the feature bundle of /a/, since no disallowed configuration would be created in this case. In this way, /a/ receives the feature value [-high] and can be a trigger of the height rule. At the same time, given that /a/ does not have a feature value on the tier on which the spreading of [+high] occurs, it does not pose any obstacle to a further spreading of this feature value to a successive target. Therefore, the fact that /a/ does not undergo and does not block the spreading of [+high] in (29)b) is easily explained. In this way I account for why /a/ behaves as a transparent neutral vowel.

9. The fact that /a/ is a transparent neutral vowel with respect to the [ATR] harmony rule is explained by supposing principle 1.6.(1). The harmony rule spreading [+ATR] cannot apply to the feature bundle of /a/ because it would create a disallowed configuration. At the same time, /a/ does not have a value of the tier on which [+ATR] is spread. Therefore, the rule can apply across it without any problem.

10. However, while it is correct to assume a filter like (26)b), probably filter (26)a) is too strong. (26)a) would predict that there is no short neutral /e/. First of all, there are native words in which short /e/ occurs with back vowels like the native /betyar/ "skamp." I believe that it would not be correct to assume that words like this are really disharmonic words similar to non-native disharmonic words. The point is then that in non-native words, /e/ can also behave as a neutral vowel. For example, in the following words

Agnes	'Agnes'
dzsungel	'jungle'

which have the following doublets

Agnesnek/Agnesnak	'to Agnes'
dzsungelnek/dzsungelnak	'to the jungle'

I could propose that instead of the auxiliary filter (26)a), we have the rule (i) that applies after the Redundancy rule has applied:

(i)	-back	-->	-back
	-low		+low
	-high		-high

(i) merges an underlying neutral /e/ with harmonic low [ɛ]. I suppose that this merging creates ambiguous superficial representations which allow two possible underlying representations.

11. Observe that the two filters *[-continuant, +voice] and *[+continuant, +voice]/[____, -sonorant] cannot be subsumed under a simple filter like *[-sonorant, +voice]. In fact, we have a consonantal system with voiced stops but not with voiced fricatives, or systems

with voiced fricatives but not voiced stops. Therefore, two different UG filters must be established; one that accounts for voiced stops and one that accounts for voiced fricatives. If we have only one UG filter for both these series of consonants--this would be the case of [-sonorant, +voice]--we would have to predict that if there are voiced stops in a system, there are also voiced fricatives, and vice versa. This is clearly not correct.

12. A word like /hydrosfäri-ä/, in which (4) seems not to apply, is not an exception, because it can be analyzed as a compound /hydro-sfäri-/, and in compounds only the second part of the compound rules the harmonic change of the suffix (see Campbell (1980)).

CHAPTER III

UG FILTERS AND AUXILIARY FILTERS

This chapter is organized in the following way: in Section 1, I propose a tentative list of the UG filters needed to account for phonological inventories. In the same section, I hypothesize that the UG filters are organized in a complex branching hierarchy. I then propose that all of the UG filters have a well defined format. In Section 2, I discuss each UG filter introduced in Section 1. In Section 3, I argue for the existence of auxiliary filters, i.e., for the existence of filters which are not contained in the list of UG filters, but which are determined on a language-specific basis. These filters are needed in order to account for the absence of segments which should be present in an underlying inventory given the UG filters that are underlyingly violated in it. In Section 4, I show that auxiliary filters do not play a role in determining the pattern of underlying specifications of segments. This gives further support to the theory of underspecification proposed in Chapter 2, Section 3. In Section 5, I argue that certain aspects of the structuralist theory of chain shifts may be derived from the theory I am proposing by imposing restrictions on the use of auxiliary filters.

1. A TENTATIVE LIST OF UG FILTERS

In this section, I propose that the UG filters needed to account for phonological systems are those listed in (1). The list in (1) is provisional, not exhaustive, and must be verified empirically. In (1), I divide the UG filters into sets. Each set corresponds to a stricture type. Each filter will be indicated by a symbol representing the stricture type and by a Roman numeral: Symbols: S - Stops, F - Fricatives, N- Nasals, L- Liquids, G- Glides, V- Vowels, SN- sonorant. Filters with SN are intended to describe properties that hold for all sonorants. Filters with STR represent the different degrees of stricture. The filters in (1) are not in the correct hierarchical order. Their correct hierarchical order will be given in Table 1. Each UG filter in (1) will be briefly discussed in Section 2. In (1), there is no filter to account for clicks, because I do not have a clear idea of the UG filters needed to describe these segments at this point in my research. Complex segments like \widehat{kp} are represented by the generic filter *[place, place]/[__, -cont. , -sonor.]. This filter must actually be interpreted as a template for other filters like *[-cont., dorsal, labial], *[-cont., dorsal, coronal], etc., with different hierarchical positions (see discussion in section 2). Recall that I use the symbols [-syllabic] and [+syllabic] to represent syllable margin and syllable nucleus .respectively.[1].

(1)

UG FILTERS

- STR.I. * [+consonantal, -sonorant]
STR.II. * [+consonantal, +sonorant]
STR.III. * [-consonantal, -sonorant]
STR.IV * [-consonantal, -continuant]
STR.V. * [-sonorant, -continuant]
STR.VI. * [-sonorant, +continuant]
STR.VII. * [+sonorant, +nasal]
STR.VIII. * [+sonorant, +lateral]
STR.IX. * [-sonorant, +nasal]
STR.X. * [-sonorant, +lateral]
- S.I. * [-cont., labial]/[____, -sonorant]
S.II * [labial, +round]/[____, -continuant, -sonorant]
S.III. * [-cont., dorsal]/[____, -sonorant]
S.IV. * [-cont., -back]/[____, -sonorant]
S.V. * [-cont., -high]/[____, -sonorant]
S.VI. * [-cont., +low]/[____, -sonorant]
S.VII. * [-cont., +distributed]/[____, -sonorant]
S.VIII * [-cont., -anterior]/[____, -sonorant]
S.IX * [place, place]/[____, -cont., -sonorant]
S.X * [-cont., +voice]/[____, -sonorant]
S.XI * [-cont., +spread gl.]/[____, -sonorant]
S.XII * [-cont., +constricted gl.]/[____, -sonorant]
S.XIII * [+spread gl., +voice]/[____, -cont., -sonorant]
S.XIV * [+constricted gl., +voice]/[____, -cont., -sonorant]

S.XV	*[-cont., +strident]/[____ , -sonorant]
F.I	*[+cont., -anterior]/[____ , -sonorant]
F.II	*[+cont. labial]/[____ , -sonorant]
F.III	*[+cont., dorsal]/[____ , -sonorant]
F.IV	*[+cont., +back]/[____ , -sonorant]
F.V	*[+cont., +low]/[____ , -sonorant]
F.VI	*[+cont., -high]/[____ , -sonorant]
F.VII	*[+continuant, -distributed]/[____ , -sonorant]
F.VIII	*[+cont, +voice]/[____ , -sonorant]
F.IX	*[+cont., +spread gl.]/[____ , -sonorant]
F.X	*[+cont., +constricted gl.]/[____ , -sonorant]
F.XI	*[+cont., -strident]/[____ , -sonorant]
F.XII	*[-strident, +voice]/[____ , +cont., -sonorant]
F.XIII	*[+strident, +voice]/[____ , +cont., -sonorant]
F.XIV	*[+spread glot., +voice]/[____ , +cont., -sonorant]
F.XV	*[+constricted glot., +voice] ____ , +cont., -sonorant]
N.I	*[+nasal, labial]
N.II	*[+nasal, -back]
N.III	*[+nasal, dorsal]
N.IV	*[+nasal, -high]
N.V	*[+nasal, +low]
N.VI	*[+nasal, +distributed]
N.VII	*[-anterior, -distributed]/[____ , +nasal]]
N.VIII	*[-anterior, +distributed]/[____ , +nasal]]

N.IX	*[+nasal, -voice]
N.X	*[+nasal, +constricted gl.]
N.XI	*[+nasal, +continuant]
L.I	*[+sonorant, -nasal]
L.II	*[+lateral, -back]
L.III	*[+lateral, +back]
L.IV	*[-anterior, -distributed/[__ , +lateral]
L.V	*[+lateral, -high]
L.VI	*[+lateral, labial]
L.VII	*[+lateral, +low]
L.VIII	*[-anterior, +distributed/[__ , +lateral]
L.IX	*[+lateral, +strident]
L.X	*[+lateral, +nasal]
L.IX	*[+sonorant, -lateral]/ [__ , -nasal]
SN.I	*[+sonorant, -voice]
SN.II	*[+sonorant, +spread gl.]
SN.III	*[+sonorant, +constricted gl.]
SN.V	*[+sonorant, +strident]
G.I	*[-consonantal, -syllabic]
G.II	*[-syllabic, -high]

V.I	*[-consonantal, +syllabic]
V.II	*[+syllabic, +low]
V.III	*[+syllabic, +high]
V.IV	*[-high, -low]
V.V	*[+low, -back]
V.VI	*[-high, +ATR]
V.VII	*[-back, +round]
V.VIII	*[+high, -ATR]
V.IX	*[+back, -round]/[____ , -low]
V.X	*[+low, +ATR]
V.XI	*[+low, +round]
G&V.I	*[-consonant., +nasal]
V.XII	*[+low, +high]

I hypothesize that the set of UG filters in (1) is organized as a complex hierarchical tree. If a UG filter at a higher node in each branch is underlyingly violated, then a UG filter at a lower node in the same branch must also be underlyingly violated. At the same time, each hierarchical branch indicates the fact that if the degree of complexity of a configuration of features in violation of a filter at a certain node in this branch is allowed by the grammar, Chapter 1, then the degree of complexity of a configuration in violation of a filter at a lower node in the same branch must also be allowed by the grammar. The degree of complexity of a configuration of features is indicated by the distance between the filter and the root of the tree; the further the distance, the

I hypothesize that all UG filters are organized together as in the complex tree in Table 1. In Table 1, the UG filters have been simplified and can be derived automatically from the tree through the algorithm in (5):

- (5) Given a UG filter F:
- (i) if F is composed of only one feature, insert in F the first stricture type feature contained in a UG filter which dominates F;
 - (ii) if F is composed of two features, add the stricture type features that are contained in filters that dominate F to the environment of F;
 - (iii) (i) applies before (ii).

For example consider the filter *[labial] in the leftmost branch of Table 1a; it is composed of only one feature. The first stricture type feature contained in a filter that dominates it is [-continuant]. Therefore, this feature is inserted into the filter and we thus get *[-continuant, -labial]. There is another stricture type feature which dominates this filter, i.e., [-sonorant]. This feature is added to the environment of the filter so that the UG filter *[-continuant, labial]/[____, -sonorant] corresponding to S.I in (1) is created. Now, consider the UG filter *[+spread, +voice] in Table 1a. This filter contains two features. It is dominated by the stricture type features [-sonorant], [-continuant]. Therefore, by (5), it will become *[+spread gl., +voice]/[____, -sonorant, -continuant] corresponding to S.XIII.

The UG filters outside the hierarchical tree in Tables 1a and 1b are UG filters which can never be violated.

I propose that the UG filters in the peculiar hierarchical order given in Table 1 express most of the meaningful generalizations that can be made for phonological systems. Obviously, I hypothesize that a minimal number of UG filters in Table 1 must be violated in order for a phonological system to exist. At this time in my research, I am not able to say whether there is a principle that determines how many and which filters must be underlyingly violated in order to have a possible phonological system. Surely, all languages have stops, sonorants and low vowels. Therefore, the UG filters *[+consonantal, -sonorant], *[-sonorant, -continuant], *[+consonantal, +sonorant], *[-consonantal, +syllabic], and *[+syllabic, +low] must always be underlyingly violated. I assume that there is no UG filter which contains the terminal feature value [+anterior]. Therefore, I assume that all segmental inventories should have coronal [+anterior] segments.

I hypothesize that UG filters have a peculiar format. This is clear in the case of the UG filters needed to describe consonantal systems. First of all, there is a series of filters that define degree of strictures. These filters are always composed of two stricture type features, where with stricture type features I mean features like [sonorant], [continuant], [nasal] and [lateral]. All the other UG filters needed to describe consonantal systems constrain the cooccurrence of a stricture configuration with either a place of articulation configuration or a state

of the glottis configuration. In other words, all UG filters needed to describe consonantal systems contain either one stricture type feature or a combination of stricture type features together with one of the following features: (i) a stricture feature; (ii) a place feature; (iii) a terminal feature value defining the positions of an articulator; (iv) a terminal feature value describing the state of the glottis. I will therefore propose the following principle: (I call the UG filters needed to describe consonantal systems consonantal UG filter)

- (6) All consonantal UG filters constrain the cooccurrence of a given stricture configuration either with another stricture configuration or with a place configuration, or with a state of the glottis configuration.

I assume that no UG filters violate principle (6).

At this point, I am unable to say whether there is any generalization that can be expressed about the UG filters needed to describe vowel systems (I call them vocalic UG filters). If the association with a syllabic nucleus, which I represent with the symbol [+syllabic, ____], can be thought of as representing a degree of stricture, i.e., the most open degree of stricture of the oral cavity, then vocalic UG filters also respect principle (6). And therefore principle (6) holds for all UG filters. The problem posed by the vocalic UG filters, however, concerns the constraints on the combinations of terminal feature values found in them. It is clear that most of the vocalic UG filters, i.e., those of the main sub-branch associated with the vocalic UG filters, define the degree of

height found in vowel systems. However, vocalic UG filters like *[+low, +round], *[+low, -back], *[+round, -back] and *[+back, -round]/ [____, -low] do not have anything to do with the degree of height. Instead they appear to exclude vowels which are not acoustically optimal. However, more research is needed in this area.

The UG filter hierarchical tree is of course an idealized representation: there are many phonological systems in which some of the segments predicted to be present by the tree are absent. In Section 3, I will discuss some of these situations in which a segment predicted to be present by the UG filter hierarchical tree is absent.

2. COMMENTS ON THE UG FILTERS IN (1).

In this section, I will briefly discuss the UG filters I am proposing. With each of the filters I am proposing, it must be possible to express a meaningful generalization on the composition of phonological alphabets. I will use the following terminology: I will say that a UG filter accounts for the presence/absence of a segment or a class of segments to indicate the fact that when that filter is underlyingly violated in a phonological alphabet, that segment or class of segments is present in that phonological alphabet and the fact that when that filter is underlying in a phonological alphabet, that segment or class of segments is absent in that phonological alphabet.

With the UG filters in (1) in the hierarchical ordering given in the

tables 1a and 1b, I attempt to express formally the generalizations on phonological systems made by Maddieson (1984). I want to stress the fact that the UG filters I propose must not be considered to be definitive, and that they must carefully reconsidered and refined. I consider the filters proposed in (1) to be just a first step towards the elaboration of the appropriate set of UG filters needed to describe phonological systems.

The UG filters *[+consonantal, -sonorant], *[+consonantal, +sonorant], *[-sonorant, -continuant], *[-sonorant, +continuant], *[+sonorant, +nasal], *[+sonorant, +lateral], [+sonorant, -lateral]/[___ , -nasal] are needed to determine the degrees of stricture that are present in phonological alphabets. The UG filters *[+consonantal, -sonorant], *[+consonantal, +sonorant], *[-sonorant, -continuant] must be always violated: all phonological alphabets have stops and sonorants. The UG filters *[-sonorant, +continuant], *[+sonorant, +nasal], *[+sonorant, +lateral], *[+sonorant, -lateral]/[___ , -nasal] may instead be underlying filters in phonological alphabets, although only one of them may be underlying in a given phonological system (I do not understand the reasons of this restriction at this point of my research): thus we have phonological alphabets that do not have either the series of fricatives, or the series of nasals, or the series of liquids. The UG filters *[-consonantal, -sonorant], *[-consonantal, -continuant], *[-sonorant, +nasal], *[-sonorant, +lateral] may never be underlyingly violated and therefore they will be underlying filters in all phonological alphabets. The unviolable UG filters *[-consonantal, -sonorant] and *[-consonantal, -continuant] state that all nonconsonantal segments are redundantly

sonorant and continuant. The unviolable UG filters *[-sonorant, +nasal] and *[-sonorant, +lateral] indicate that there are no segments which are nonsonorant and nasal or nonsonorant and lateral.

Let us consider the UG filters that concern stops, i.e., the filters that are preceded by S in (1). Observe, first of all, that there is no UG filter that constrains the occurrence of the feature value [+anterior] in stops. Therefore, the configuration [-continuant, +anterior] will never be constrained in a phonological system. In this way, I express the fact that dental or alveolar stops are present in almost all languages of the world, the only exception being Hawaiian and some Samoan dialects. The UG filters *[-continuant, labial], *[-continuant, dorsal], *[-continuant, -back], *[-continuant, -high], *[-continuant, +low] are needed to determine what place of articulation are used among stops in phonological alphabets. *[-continuant,labial] accounts for the presence/absence of labial stops. Give the independent UG filter *[labial, +round]/[— , -continuant], a feature bundle that contains the feature [labial] and [-continuant] will be specified as [-round] according to the theory of Underspecification proposed in Chapter 2. (2) Therefore, the UG filter *[-continuant, labial] accounts for the presence/absence of labial unrounded stops in phonological alphabets, whereas the filter *[labial, +round]/[— , -continuant] accounts for the presence/absence of labial rounded stops. Given the hierarchical position of the latter filter, labial rounded stops can be present in a phonological alphabet, only if labial unrounded stops are also present in this phonological alphabet. Let us consider the UG filter *[-continuant,

dorsal]. Given the independent UG filters *[-continuant, -back], *[-continuant, -high] and *[-continuant, +low], a feature bundle that contains only the feature [dorsal] and [continuant], but not the features [-back], [-high] and [+low], will be specified with the features [+back], [+high] and [-low] according to the theory of underspecification proposed in Chapter 2, Section 3.⁽³⁾ In this way, we obtain the feature bundle of a velar stop. Thus, the filter *[-continuant, dorsal] accounts for the presence/absence of velar stops in phonological alphabets. Let us now consider the UG filter *[-continuant, -back], a feature bundle that contains only the feature [-back] and [-continuant] must be specified as [+high], [-low] according to the theory of underspecification I am proposing. This is the feature bundle of palatal stops. Therefore, the UG filter *[-continuant, -back] accounts for the presence/absence of palatal stops in phonological alphabets. Let us now consider the UG filter *[-continuant, -high], a feature bundle that contains only the feature [-high] and [-continuant] must be specified as [+back], [-low] according to the theory of underspecification I am proposing. This is the feature bundle of uvular stops. Therefore, the UG filter *[-continuant, -high] accounts for the presence/absence of uvular stops in phonological alphabets. Let us now consider the UG filter *[-continuant, +low], a feature bundle that contains only the feature [+low] and [-continuant] must be specified as [+back] [-high] according to the theory of underspecification I am proposing. This is the feature bundle of pharyngeal stops. Therefore, the UG filter *[-continuant, -back] accounts for the presence/absence of pharyngeal stops in phonological alphabets. Given the hierarchical position of the filters *[-continuant, -back],

*[-continuant, -high] and *[-continuant, +low] with respect to the UG filter *[-continuant, dorsal], palatal stops, uvular stops, and pharyngeal stops may be present in a phonological alphabet only if velar stops are also present in this alphabet.

The UG filter *[-continuant, +distributed] is needed to account for the presence/absence of laminal stops in phonological alphabets. By giving this filter a position far away from the root of the UG filter hierarchical tree, I want to represent the phonological complexity of laminal stops that --I assume--is reflected in their rare occurrence in phonological alphabets. With its hierarchical position at the end of a branch that contains also the filters *[-continuant, labial], *[-continuant, dorsal], I want to express the fact that laminal stops may occur only in phonological alphabets that contain also labial, velar and naturally coronal stops. I assume that there is no UG filter that constrain the feature [-distributed] in the feature bundle of stops. With this , I want to express the fact that phonological alphabets always contain apical coronal stops so that laminal stops can occur in a phonological alphabet only if also apical stops occur in this alphabet.[4]

The UG filter *[-continuant, -anterior] is needed to account for the presence/absence of post-alveolar stops. This UG filter crucially interacts with the filter *[-continuant, +distributed]. A feature bundle that contains violations of both the UG filters *[-continuant, +distributed] and *[-continuant, -anterior], i.e., the feature bundle of a post-alveolar laminal stop, is phonologically highly complex. Therefore,

I predict that post-alveolar laminal stops have a very rare occurrence in phonological alphabets. A feature bundle in which only the filter *[-continuant, -anterior] is underlyingly violated, i.e., the feature bundles of retroflex stops--I assume that retroflex stops are [-distributed] as proposed in Chomsky and Halle (1968)-- is instead less complex phonologically and we can expect that it occurs more frequently in phonological alphabets. With the hierarchical positions that I assign to this filter, I intend to express the fact that post-alveolar stops occur in phonological alphabets only if velar, labial and coronal stops also occur in these alphabets.

The UG filter *[place, place]/[____, -continuant] represents a template for UG filters that constrain the cooccurrence of place features inside the same feature bundle, i.e., for filters that constrain the presence/absence of complex segments. It represents a series of filters which are organized hierarchically, which include the following: *[dorsal, labial]/[____, -continuant] which accounts for the presence/absence of labial velar stops like /k^hp/ of Yoruba, *[coronal, labial] which accounts for the presence/absence of coronal labial stops as /p^ht/ of Margi, and *[labial, coronal, velar], which accounts for [labial-coronal-velar stops] as /tk^hw/ of Kinyarwanda (cf. Sagey (1986)). At this point in my research, due to the limits of my knowledge on complex segments, I am unable to propose any tentative hierarchical ordering for the UG filters that account for them. I can only observe that the UG filter *[dorsal, labial] must have a hierarchical position lower than that of the other just-mentioned filters, given that labial-velar segments are

more frequently found in phonological alphabets (cf. Maddieson (1984).

Let us now consider the UG filters that constrain the occurrence of laryngeal features in the feature bundle of stops. First of all, I assume that there is no UG filter that constrains the feature *[-voice] in feature bundles that contain the feature *[-continuant]. [5] Therefore, the configuration [-continuant, -voice] is always possible in a phonological alphabet. In this way, I express the fact that all phonological alphabets contain a voiceless stop series. The UG filter *[-continuant, +voice] accounts for the presence/absence of voiced stops. The UG filter *[-continuant, +spread glottis] accounts for the presence/absence of aspirated stops. The UG filter *[+spread glottis, +voice] accounts for the presence of voiced aspirated stops. With the hierarchical position in the tree of this filter, I express the fact that the presence of a voiced aspirated stops in a phonological alphabet requires the presence of both aspirated stops and voiced stops in this phonological alphabet.

The UG filter *[-continuant, +constricted glottis] accounts for the presence/absence of ejective stops in phonological alphabets. The UG filter *[+voice, +constricted glottis]/[____ , -continuant] accounts for the presence/absence of laryngealized voiced stops in phonological alphabets. The hierarchical position of this filter indicates that the presence of voiced laryngealized stops in phonological alphabets requires the presence of both voiced stops and ejective stops.[6] The UG filter *[-continuant, +strident] may never be violated, and it is needed to represent the fact that stops are always non-strident.

Let us consider the UG filters needed to account for fricatives. I assume that there is no UG filter which constrains the cooccurrence of the features [+continuant] and [+anterior]. Therefore, the configurations *[+continuant, +anterior] will never be blocked in any phonological alphabets. I also assume that there are no UG filters which block the features [-voice], [+continuant] and the features [+strident], [+continuant]. Therefore, I propose that the feature bundle that contains the features [+continuant, +anterior, -voice, +strident], i.e., the feature bundle of /s/ will be present in all phonological alphabets.

The UG filter *[+continuant, -anterior] accounts for the presence/absence of post-alveolar fricatives, the UG filter *[labial, +continuant] accounts for the presence/absence of labial fricatives. The hierarchical position of these two filters in the tree indicates that labial fricatives can occur in a phonological alphabet only if post-alveolars also occur in this phonological alphabet. Given the presence of the UG filters *[+continuant, -back], *[+continuant, +low], *[+continuant, +high], a feature bundle which contains the feature [+continuant, +dorsal] must be specified as [+high] [-low] [+back]. Thus, we have the feature bundle of a velar continuant. Therefore, the UG filter *[+continuant, dorsal] accounts for the presence/absence of velar fricatives. The UG filter *[+continuant, -back] constrains the presence/absence of palatal fricatives. The UG filter *[+continuant, -high] accounts for the presence/absence of uvular fricatives. The UG filter *[+continuant, +low] accounts for the presence/absence of pharyngeal fricatives. Observe that I assume that the presence of palatal fricatives in a phonological

alphabet does not require the presence of velar fricatives. Therefore, I place the filter *[+continuant, -back] in a position in the hierarchical tree not dominated by the UG filter *[+continuant, dorsal].

The filter *[+continuant, -distributed] constrains apical fricatives. I assume that it may never be violated. In this way, I account for the fact that there are no phonological alphabet in which there is a contrast between apical and laminal continuants. From this assumption, it follows that fricatives should normally be laminal. This seems correct in the case of strident fricatives. A problem, however, can be posed by nonstrident coronal fricatives that can be considered to be laminal. Probably, this filter must be constrained so that it applies only to strident fricatives.

Let us consider the UG filters which constrain laryngeal features in the feature bundle of fricatives. Given that there is no UG filter which constrains the feature [-voice], if fricatives are present in a phonological alphabet, then the series of voiceless fricatives must be present.

The UG filter *[+continuant, +voice]/[____, -sonorant] constrains the presence/absence of voiced fricatives. Given what I said before, the UG filter hierarchy predicts that if voiced fricatives are present in a phonological alphabet, also voiceless fricatives must be present in this phonological alphabets.

The UG filter *[+continuant, +spread glottis] constrains the

presence/absence of aspirated fricatives in phonological alphabets. The UG filter $*[+continuant, +constricted\ glottis]$ accounts for the presence/absence of ejective fricatives in phonological alphabets. The UG filters $*[+spread\ glottis, +voice]/[____, +continuant]$ and $*[+constricted\ glottis, +voice]/[____, +continuant]$ may never be violated. Therefore, no phonological alphabet can contain voiced aspirated fricatives or voiced laryngealized fricatives.

There is no UG filter which contains the feature $[+strident]$ in fricatives. Therefore, if there are fricatives in a phonological system, a series of them will be composed of strident fricatives. The UG filter $*[+continuant, -strident]$ accounts for the presence/absence of nonstrident voiceless fricatives in phonological alphabets. Given what was said before, nonstrident fricatives can be present in a phonological alphabet only if strident fricatives are also present in this phonological alphabet. The UG filter $*[-strident, +voice]$ accounts for the presence/absence of voiced nonstrident fricatives. The hierarchical position I assign to this filter indicates that the presence of voiced nonstrident fricatives in a phonological alphabet does not imply the presence of nonstrident voiceless fricatives, but it implies the presence of voiced fricatives.

Let us now consider the UG filters that concern sonorants. I assume that there is no UG filters that constrain the feature $[+voice]$, $[-spread\ glottis]$ and $[-constricted\ glottis]$ in the case of sonorants. Therefore, there will always be a series of sonorants that are voiced nonaspirated nonejective in every phonological alphabets. The UG filters

*[+sonorant, -voice], *[+sonorant, +spread glottis], *[+sonorant, +constricted glottis] account for the presence/absence of voiceless sonorants, aspirated sonorants and laryngealized sonorants. With the hierarchical position of these filters, I express the fact that these sonorant series are phonologically very complex and therefore rarely occur in phonological alphabets.

The UG filter *[+sonorant, +nasal] accounts for the presence/absence of nasal consonants in phonological alphabets. I assume that there is no UG filter that constrain the feature value [+anterior] in nasals. In this way, I express the fact that dental/alveolar nasals are always present in the series of the nasals, if the series of the nasals is present in a phonological alphabet. The UG filter *[+nasal, +labial] accounts for the presence/absence of labial nasals. Given the UG filters *[+nasal, -back], *[+nasal, -high] and *[+nasal, +low], a feature bundle that contains the feature [+nasal] and [dorsal], but not the feature [-back], [-high] and [+low] must be specified with the features [+back], [+high] and [-low]. This is the feature bundle of a velar nasal. Therefore, the UG filter *[+nasal, dorsal] accounts for the presence/absence of velar nasals in phonological systems. The UG filter *[+nasal, -back] accounts for the presence/absence of palatal nasals. I assume that this filter has a hierarchical position independent of that of the filter *[+nasal, dorsal]. In this way, palatal nasals can occur in a phonological alphabet independently of the presence of velar nasals in this alphabet. The UG filters *[+nasal, -high] and *[+nasal, +low] may never be violated. Therefore, uvular or pharyngeal nasals will never appear in a phonological alphabet. The UG filter *[+nasal, +distributed]

accounts for the presence/absence of laminal nasals. The hierarchical position I assign to this filter indicates that laminal nasals can appear in a phonological alphabet only if velar nasals are also present in this phonological alphabet. The UG filter *[-anterior, -distributed]/[___, +nasal], accounts for the presence of retroflex nasals. The hierarchical position I assign to this filter indicates that retroflex nasals can appear in a phonological alphabet only if velar nasals are also present in this phonological alphabet. I assume that the UG filter *[-anterior, +distributed]/[___, +nasal], may never be violated. Therefore, I assume that post-alveolar laminal nasals are not found in phonological alphabets.

The UG filter *[+nasal, +strident] may never be violated. Thus nasal strident segments will never be found in phonological alphabets.

A problem with my proposal must be pointed out at this point. One of the generalizations on nasal systems made by Maddieson (1984) (cf. also Ferguson (1963)) is that in a given phonological alphabet, the presence of a nasal at a given place of articulation usually implies the presence of a stop at the same place of articulation. Now, there is no way to express this generalization in the theory I am proposing. More research is therefore needed on this point in order to modify the theory I propose so that it can account for this generalization.

Let us consider the UG filters that I propose to account for liquids. I do not have any clear idea on what filters are needed to account for liquids. Therefore, all my proposals here must be considered to be very

tentative.

I propose the UG filter *[+sonorant, -nasal] to account for phonological alphabets that contain only one liquid. According to Maddieson (1984), when this occurs, the single liquid is a flap. In order to account for this, I assume the following: if the UG filter *[+sonorant, -nasal] is violated, but the UG filters *[+sonorant, +lateral], *[+sonorant, -lateral]/[___, -nasal] are not violated, we have a segment with the feature bundle that contains only the features [+sonorant], [-nasal]. I assume that this feature bundle is specified with the feature value [+anterior] that is the only place terminal feature value that can be available at this position in the hierarchy. I assume that a feature bundle that contains the features [+sonorant], [-nasal], [+anterior], but no value for the feature [lateral] is implemented phonetically as a flap. I propose that if the UG filters *[+sonorant, +lateral] and *[+sonorant, -lateral]/ [--, -nasal] are violated, a feature bundle that contains the features [+sonorant], [-nasal], but not [+/-lateral] cannot exist. Therefore, I assume that the violation of the filter *[+sonorant, -nasal] cannot create an independent liquid series in a phonological alphabet that also contains laterals and R-sounds.

Let us now consider the filters that I propose in the case of laterals. The UG filter *[+sonorant, +lateral] accounts for the presence/absence of laterals in phonological alphabets. I assume that there is no UG filter that constrains the feature value [+anterior] in the case of laterals. In this way, I obtain the fact that if laterals are present in a phonological alphabet, one of them must be an anterior lateral. The

UG filter *[+lateral, -back:] accounts for the presence/absence of front laterals in phonological alphabets. The UG filter *[-anterior, -distributed]/[__ , +lateral] accounts for the presence/absence of retroflex laterals. The hierarchical position I assign to this filter indicates that retroflex laterals may be present in a phonological alphabet independently of other filters. The UG filters *[+lateral, +labial], *[+lateral, -high] and *[+lateral, +low] may never be violated. Therefore, I assume that no phonological alphabet may contain labial laterals, uvular laterals and pharyngeal laterals. These are in fact segments that are not possible from an articulatory point of view. The UG filters *[-anterior, +distributed]/[__ , +lateral] and *[+lateral, +back]. I assume that no phonological alphabets contain laminal post-alveolar laterals and velar laterals and that therefore these UG filters are never violated. However, counterexamples to this claim are reported in Maddieson (1984). More research is needed on this point.

The UG filter *[+lateral, +strident] accounts for the presence/absence of lateral strident segments like the lateral fricatives of Kabardian or Chukchi.

The UG filter *[+lateral, +nasal] may never be underlyingly violated and accounts for the fact that there are no phonological alphabets with lateral nasals or nasal lateral.

Let us now consider R-sounds. With the branch that connects the UG Filters *[+sonorant, +lateral] and *[+sonorant, -lateral]/[__ , -nasal] horizontally, I indicate that the violation of one of these two filters

implies the violation of the other. Therefore, a phonological alphabet that contains laterals must also contain R-sounds and viceversa.

I assume that there is no UG filter that constrain the feature value [+anterior] in R-sounds. In this way, if R-sounds are present in a phonological alphabet, at least one of them must have a dental/alveolar articulation.. The UG filter *[-anterior, -distributed]/[___ , -lateral, -nasal] accounts for the presence/absence of retroflex R-sounds. I assume that the UG filter *[-anterior, +distributed]/[___ , -lateral, -nasal] may never be violated.

It is not clear to me how to treat uvular trills. More research is needed on this point.

The UG filters *[-lateral, labial]/[___, -nasal] and *[-lateral, dorsal]/[___ , -nasal] may never be violated, given that it is impossible to produce R-sounds with the lips or with the tongue dorsum.

The UG filter *[-lateral, +strident]/[___ , -nasal] accounts for the presence/absence of strident R-sounds like /ř/ of Czeck.

In the case of glides, I proposed only the unviolable UG filter *[-syllabic, -high]/[___ , -consonantal] that accounts for the fact that there no nonhigh glides. The reason of this is that at this point of my research, I do not know what filters are needed to account for glides. I leave this topic to future research.

I will not discuss the UG filters that I propose for vowels, since they have been extensively discussed in the preceding chapters.

3. AUXILIARY FILTERS

Given the UG filters that are underlyingly violated in a phonological inventory, we expect that a certain set of segments is present in this phonological inventory. This is not always true. There are phonological inventories in which we do not find segments that should be present, given the UG filters that are underlyingly violated in these inventories.

Given the segments present in an underlying inventory, the theory of UG filters predicts that the segments that are absent from this inventory are divided into two classes. One class contains the segments which cannot occur in this inventory given the UG filters that are underlying in it. I will say that these segments are necessarily absent from this inventory. The other one contains the segments that could occur in this phonological inventory, but are actually absent from it. I will say that these segments are accidentally absent from this inventory. In the next pages, I will discuss a series of phonological inventories with segments that are accidentally absent.

The first of these is the vowel system of Hungarian, discussed in Chapter 2, Section 3. I will briefly repeat my analysis here. Hungarian has the following vowel system:

(1)	short vowels			long vowels		
	front		back	front		back
	-rd	+rd		-rd	+rd	
high	i	ü	u	i:	ü:	u:
mid		ö	o	e:	ö:	o:
low	æ		ɒ			a:

The interesting characteristic of this vowel system is given by the asymmetries that we find between the short and long series: a long mid front vowel is present, but a short one is absent. At the same time, a short low front vowel is present, but a long one is absent. Now according to the UG filters underlyingly violated in (1), the short mid front vowel and the long low front vowel should be present in the vowel inventory of Hungarian. But, as a matter of fact, these segments are not present in this inventory. There are two options: one is to assume that these segments are underlyingly present in the vowel inventory of Hungarian and that there are surface rules that change these underlying vowels into other vowels of the system. The other option is to assume that these segments are simply absent from the underlying inventory. It is possible to demonstrate that the second option is the correct one.

Let us examine the first option. I will discuss the case of the long front low vowel æ:. Given the harmonic behavior of the suffix na:l / ne:l, which displays the alternant with the long low back vowel after stems with back vowels and the alternant with the mid long front

vowel after stems with front vowels, we should hypothesize that there is a rule which changes long front low vowels into long front mid vowels, i.e. a rule like that in (2):

(2) $\text{æ:} \rightarrow \text{e:}$

In this way, we can account for the behavior of the suffix na:l / ne:l: It contains an underlying /a:/. The harmony rule changes it into long æ: when it occurs after a stem with front vowels. Then, rule (2) changes this æ: into e:, so that we get ne:l. If this is correct, we would expect that there are cases of surface e: which actually represent an underlying æ:. Observe that given the behavior of the suffix na:l / ne:l, we have to assume that rule (2) applies after the harmony rule applies. Now, æ: should behave as a harmonic front vowel, as its short counterpart does. Therefore, we would expect that in some instances surface e: should behave as a harmonic front vowel and trigger front harmony, precisely when surface e: is derived from underlying /æ:/. But this is absolutely not correct: long e: is always a neutral vowel in Hungarian. Therefore, we can reject the hypothesis that the vowel æ: is present in the underlying vowel system of Hungarian and is later merged with e: by rule (2). Thus, we must say that the long low front vowel æ: is underlyingly absent from the vowel inventory of Hungarian.

The problem is now whether or not the absence of a vowel like æ: from the underlying inventory of Hungarian is to be represented by a

language specific constraint. There are two possibilities: one is to propose that only UG filters are possible, and that therefore no language specific constraint can be formulated to describe a situation like that of Hungarian; the other possibility is to propose that in addition to UG filters, language specific filters are also possible (I will call them auxiliary filters). The second possibility appears to be the correct one. If no auxiliary filter were possible, we would expect that the long /a:/ of the suffix /na:l/ be freely changed into æ: when this suffix occurs after a stem with front vowels. In fact, if there were no constraint on the long front low vowel æ:, nothing could block the surfacing of æ:. However, as we know, this is not correct. In fact na:l becomes ne:l and not næ:l after a stem with harmonic front vowels. This fact can be nicely accounted for if we hypothesize, as I did in Section 3, Chapter 2, an auxiliary filter like that in (3):

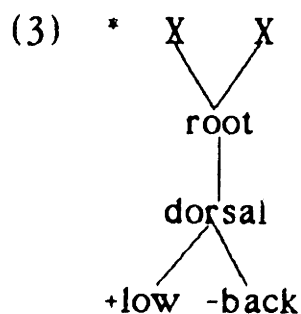

I hypothesize that auxiliary filters like that in (3) may trigger the application of clean up rules to repair configurations which violate them. This is what happens in Hungarian when the harmony rule applies to the vowel of the suffix na:l, as in (4):

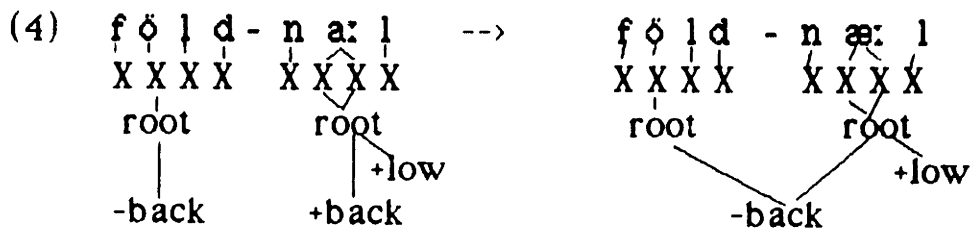

In the output of the harmony rule in (4) we have the configuration disallowed by (3). I hypothesize that delinking of [+low] is used to repair this configuration. Therefore, we obtain the form in (5), which is the correct form.

I shall now consider two other examples in support of the hypothesis that auxiliary filters are needed to represent the accidental absence of segments from a segmental inventory.

The Australian language Bandjalang described by Crowley (1978) has the vowel system in (6)

- (6)
- | | |
|------|------|
| i(:) | u(:) |
| ε(:) | |
| a(:) | |

In Bandjalang, there is a rule that lowers long high vowels, as clearly shown by Crowley (1978). This is illustrated in the following alternation:

	imper.	present	past definite	future	purpos.
(7)	wɑɖɛ:	wɑɖɛ:lɑ	wɑɖɛni	wɑɖɛ:ŋ	wɑɖɛyɑ: 'say'

In (7) the long front high vowel /i:/ is lowered to a long front mid vowel. It is interesting to see what happens when the target of the rule is the high back vowel /u/. We expect that the same rule would lower it, when it is long. However, this is not what we find. As a matter of fact, as we can see in (8), long u is not only lowered, but also fronted.

	imper.	present	past definite	future	purpos.
(8)	buliɖɛ:	buliɖɛ:lɑ	buliɖɛni	buliɖɛ:ŋ	buliɖɛyɑ 'bump'

As we can see in (8), the rule of lowering produces /ɛ:/, when it applies to the lengthened /u:/, not the [ɔ:] which would otherwise be expected.

The problem is to give an explanatory analysis of these facts. First of all, I reject the possibility that the lowering rule may be stated as in (9):

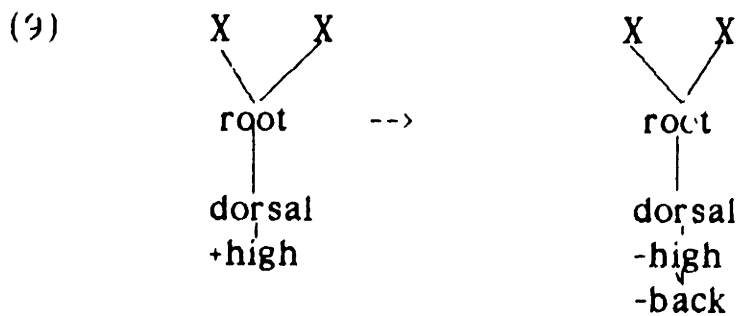

A rule like (9) would be description of the facts and would not explain anything. I hypothesize that an explanatory account of the facts is possible only if the structure of the vowel inventory of Bandjalang is taken into consideration. I hypothesize that the lowering rule is that in (10):

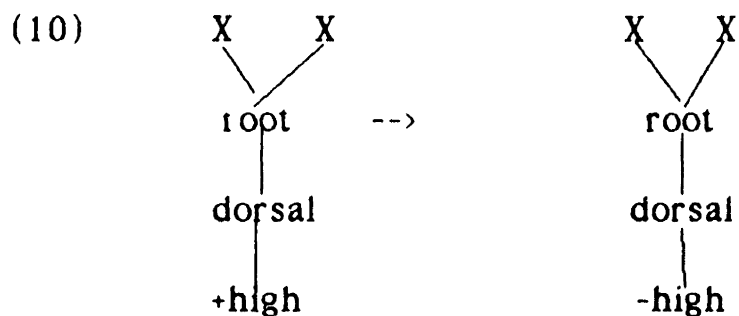

Rule (10) produces the mid front vowel [ɛ:] when it applies to a long front high vowel and the mid back vowel ɤ: when it applies to a long high back vowel.

The crucial point now is that the vowel ɤ: is not present in the vowel inventory of Bandjalang. I hypothesize that the underlying inventory of Bandjalang is identical to the surface one that we see in (6). Given that there is a mid-vowel in this inventory, we have to conclude that the UG filter *[-high, -low] is underlyingly violated in Bandjalang. This predicts that the back mid-vowel should also be present in this phonological inventory. If we hypothesize that the accidental absence of segments must be represented by auxiliary filters, we must conclude that the following auxiliary filter holds in the phonology of Bandjalang:^[7]

(11) *[-high, +back]/[-low, ____]

If I am correct in assuming that auxiliary filters can trigger the application of clean up rules to repair configurations of features which violate them, we have a straightforward explanation of the change u: -- > ε. In fact, the application of rule (10) to high back vowels creates the configuration [-high, +back, -low] which is disallowed by (11). If we suppose that this configuration is repaired by delinking of [+back], we obtain the configuration [-high, -low, -back], which is the configuration peculiar to ε. In this way, a very simple and straightforward analysis of vowel lowering in Bandjalang is achieved.^[8] Observe that if we reject the hypothesis that an auxiliary filter like that in (11) is present in Bandjalang, we are forced to complicate the analysis of vowel lowering. I have already rejected the possibility of using (9) to explain this phenomenon. Let us consider another alternative.

Let us hypothesize, for example, that the vowel inventory of Bandjalang is underlyingly that in (12) and that there is the late context-free rule in (13) which changes all /æ/ into [ε]:

(12) i u
 æ a

(13) æ ---> ε

In the vowel system in (12), the UG filter *[-high, -low] is underlying. This underlying filter cannot distinguish the configurations created by the application of (10) to long high front vowels from the configurations created by the application of (10) to long high back vowels. Both of them would be treated in the same way. Therefore, in order to explain the fact that u: is not simply lowered but also fronted when it is lengthened, we must assume that the lowering rule is actually that in (9), or that it is still that in (10), but that there is an ad hoc rule that changes the ɔ: obtained through (10) into ɛ:. Neither these alternatives are very explanatory.

The identical problem would arise if we suppose that the underlying inventory of Bandjalang is that in (14) and that there is a late context-free rule like that in (15) which changes ɔ into ɛ:

(14) i u
 ɛ ɔ
 a

(15) ɔ --> ɛ

In this case, the application of (10) to u: would produce ɔ: which would then be changed into ɛ:. The problem with this analysis is that a context-free rule like that in (15) is absolutely arbitrary. One can argue that the context-free rule in (13) is possible, since it could be interpreted as an instance of a clean up rule triggered to repair the vowel æ which has a

degree of complexity superior to that of the vowel ξ , as discussed in Chapter 1, Section 10. However, such interpretation is not possible in the case of rule (15), since ξ and ζ have an identical degree of complexity. Given the arbitrariness of (15), I assume that the analysis which proposes (14) as the underlying vowel system for Bandjalang is implausible.

I therefore believe that the best and most explanatory analysis for vowel lowering in Bandjalang is the one which assumes a vowel lowering rule like that in (10) and a auxiliary filter like that in (11).

In order to discuss the third case in support of auxiliary filters, I must introduce a new clean up strategy which I call transfer. This clean up rule can be formalized as follows:

(16) Given the feature bundle B_1 in (i):

- i) aF
- bG
- cH
- dT

where the configuration [aF, bG] is disallowed by the filter $*[aF, bG] / cH_ dT$ in the language L, find the feature bundle B_2 minimally distinct from B_1 in which the configuration [aF, bG] is allowed in L, if there is any, and

change B₁ into B₂.

- (17) In a language L, feature bundle F₁ is the feature bundle minimally distinct from another feature bundle F₂ in L if F₁ and F₂ are distinct but share the most number of features among the feature bundles in L.

An example of transfer is the change from ɨ to ɘ found in several languages, e.g., in the Philippino languages (cf. Reid (1973)). Given the feature bundle of /ɨ/ as in (18):

- (18) +high
 -low
 +ATR
 +back
 -round

in which the configuration [+back, -round] is blocked by the UG filter *[+back, -round]/ [____, -low], (16) forces us to look for the minimally distinct feature bundle in which the the configuration [+back, -round] is allowed. In a standard vowel system, there is a feature bundle that satisfies this requirement. This is the feature bundle of the vowel /a/, i.e., the feature bundle in (19). In this feature bundle we have the configuration [+back,-round], but the UG filter *[+back, -round]/ [____, -low] does not apply because there is no feature [-low]. At this point, we can apply (16) and change (18) into (19):

- (19) -high
 +low
 -ATR
 +back
 -round

In this way, $\underset{\cdot}{i}$ is changed into a.

Maddieson, in an interesting article on borrowed sounds, reports on an interesting case found in Yoruba (cf. Maddieson (1985)). Yoruba has the following stop inventory:

- (20) t k \widehat{k}
 b d g \widehat{g}

The peculiarity of the stop system in (20) is that the expected voiceless labial stop /p/ is accidentally absent. If my idea concerning auxiliary filters is correct, an auxiliary filter like (21) is needed in the phonological system of Yoruba in order to express the accidental absence of /p/.

- (21) *[labial, -voice] / [__ , -continuant]

It is interesting to see how loans containing /p/ were treated in Yoruba.

We can distinguish two historical stages. In an earlier period, loans containing /p/ were borrowed with /k^hp/ or /b/, e.g., /k^hpotogi/ 'Portuguese', /k^hpoũ/ 'pound', /k^hbò/ penny (< 'copper'). However in a more recent period, loans mostly from English (now a much more widely spoken language in the community) retain /p/, e.g. /pílò/ 'pillow', /pidzɔt/ 'Peugeot'. These two periods can be characterized in the following way: in the first period, the auxiliary filter (21) required the repair of the disallowed configuration [labial, -voice, -continuant] and therefore in pronouncing the disallowed configuration of features, the Yoruba speakers had to apply clean up rules to repair it. The two strategies that were used were delinking of [-voice] and transfer. The strategy of delinking of [-voice] does not require any explanations; transfer is realized in this way: a feature bundle that is minimally distinct from the feature bundle of the disallowed /p/ and in which the disallowed configuration blocked by (21) is possible is looked for in the phonological inventory of Yoruba. Yoruba has such a feature bundle, i.e., the feature bundle of /k^hp/. The feature bundle of the disallowed /p/ is therefore changed into the feature bundle of /k^hp/. Thus, we got the two following clean ups:

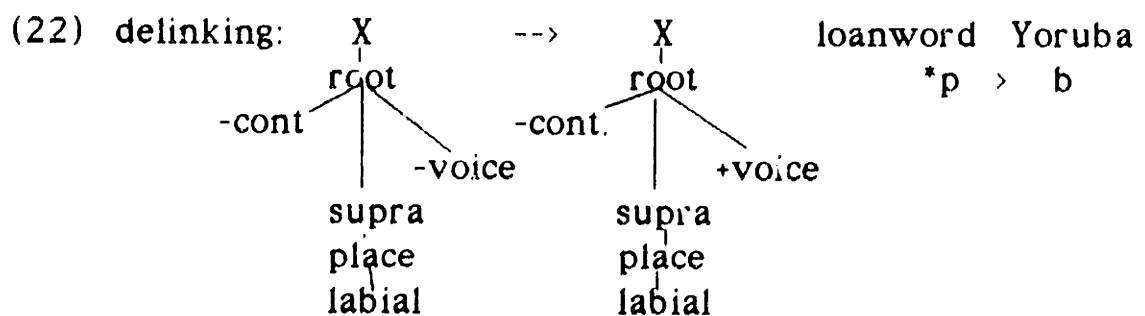

4. AUXILIARY FILTERS AND THE THEORY OF UNDERSPECIFICATION

In the preceding section, we have seen that we need devices like auxiliary filters in order to represent the accidental absence of segments from a phonological inventory, which should be present according to the UG filters underlyingly violated in that inventory.

Observe now that if underspecification were based only on the structure of the phonological inventory, we would expect that auxiliary filters play a role in determining the pattern of specification of a phonological inventory. By representing the accidental absence of segments from a phonological inventory, auxiliary filters also indicate that certain features are not used distinctively in certain feature bundles of that inventory. For example, in the following vowel inventory (1):

(1) i u
 ε
 a

the auxiliary filter needed to represent the accidental absence of ϱ also indicates that the feature [back] is not used distinctively in the mid-vowels. If the non-distinctive use of features determined underspecification, we would be required to say that the auxiliary filter

needed for (1) would determine that the feature [back] is unspecified in the case of the feature bundle of \underline{e} .

Now given the theory of underspecification outlined in Chapter 2, Section 3, which is based only on UG filters, we predict that auxiliary filters do not play a role in determining the pattern of underspecification of the phonological inventory in which they hold. This prediction is borne out, as we shall see in this section.

For example, recall the case of Hungarian discussed in the preceding section and in Chapter 2, Section 3. Long $\underline{a:}$ is accidentally absent in the Hungarian vowel system, and we need an auxiliary filter to represent its absence. The filter is repeated in (2):

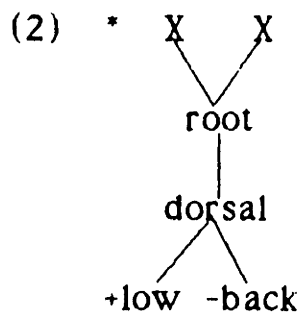

If the filter (2) could play a role in establishing underspecification, we would expect that the feature value [+back] is underlyingly unspecified in the feature bundle of long $\underline{a:}$. Therefore, we would expect that long $\underline{a:}$ behaves as a transparent neutral vowel in the vowel harmony system of Hungarian, as do the vowels \underline{i} and \underline{e} , which are unspecified

for [back] because of the underlying UG filter *[+back,-low]/ [____,-low]. Then this long a: in Hungarian would not be a trigger or an undergoer of the vowel harmony rule. But this is absolutely incorrect. As we have seen in Chapter 2, Section 3, long a: behaves like the other harmonic vowels of Hungarian. It is both a trigger and an undergoer of the harmony rule.

This case supports the hypothesis that underspecification is based only on UG filters, and not on auxiliary filters. In other words, this means that only features that are non-distinctive because of underlying UG filters are unspecified. Features that are non-distinctive because of auxiliary filters are specified. The accidental absence of segments from a phonological inventory does not determine the underlying specifications of the segments of that inventory.

Russian voicing assimilation (cf. Jakobson (1956, 1968), Halle and Vergnaud (1981), Hayes (1984), Kiparsky (1985)) provides further evidence that this hypothesis is correct. Russian has the following underlying consonantal inventory, where each phoneme may also have a palatal variant: (Given that the distinction between palatal/nonpalatal consonants in Russian does not have any bearing on the following discussion, I have omitted it in (3).)

(3) p t k
 b d g
 ts tʃ
 f s ʃ x
 z ʒ
 m n
 l
 r
 w y

I hypothesize that Russian does not have v in its underlying inventory, as hypothesized in Jakobson (1948), Halle (1973) and Lightner (1972). (See Appendix to this section for a discussion of [v].)

Now I will compare the pattern of underlying specifications predicted by a theory of underspecification based only upon UG filters, i.e., the theory of underspecification outlined in Chapter 2, Section 3, with the pattern of underlying specifications which would be predicted by a theory of underspecification that also takes auxiliary filters into

account. First, I consider the underlying specifications for the feature [voice] which are derived from the theory of underspecification based only upon UG filters. The UG filters that are of interest to us are the following:

- (4) a) *[-continuant, +voice]/[____, -sonorant]
 b) *[+continuant, +voice]/[____, -sonorant]
 c) *[+sonorant, -voice]

Given the presence of /b, d, g/ in (3), we know that the UG filter (4)a) is underlyingly violated in Russian. Given the presence of /z, ʒ/ we also know that (4)b) is underlyingly violated in Russian. There is no segment in (3) that violates (4)c). Therefore, we conclude that (4)c) is an underlying filter of Russian.

Now given principle (5) of Chapter 2., Section 3, /b, d, g/ must be underlyingly specified as [-continuant, +voice], and /z , ʒ/ as [+continuant, +voice]. Given principle (6) of Chapter 2. Section 3 , /p, t, k/ are underlyingly specified as [-continuant, -voice], because filter (4) a) is underlyingly violated and they contain the feature value [-continuant], but not [+voice]. By the same principle, /f, s, ʃ, x/ are underlyingly specified as [+continuant, -voice], because filter (4) b) is underlyingly violated and they contain the feature value [+continuant], but not [+voice]. In the same way, /ts/ and /tʃ/ are underlyingly

specified as [-voice], depending on whether we consider them to be [-continuant] or [+continuant]. In the case of sonorants which are underlyingly specified as [+sonorant], because the UG filter [+continuant, +sonorant] is underlyingly violated in Russian, the redundancy principle in conjunction with principle (3) of Chapter 2, Section 3 predicts that the feature value [+voice] is unspecified in their feature bundle. Therefore, we obtain the following pattern of underlying specification:

(5)		p	t	k	b	d	g	ts	tʃ	f	s	ʃ	x	z	ʒ	m	n	l	r	w	y
sonorant		-	-	-	-	-	-	-	-	-	-	-	-	-	-	+	+	+	+	+	+
continuant		-	-	-	-	-	-	- +	- +	+	+	+	+	+	+	-	-	-	+	+	+
voice		-	-	-	+	+	+	-	-	-	-	-	-	-	+	+					

Now let us consider the auxiliary filters which are needed for the Russian consonantal system. Given the UG filters that are violated in (3), the segments v, y, dz, dʃ should be present in the consonantal inventory of Russian. But these segments are actually absent from this consonantal inventory. If I am correct in proposing that the accidental absence of segments must be represented by auxiliary filters, as I proposed in Section 3, we need the following auxiliary filters for the consonantal inventory of Russian:

For the accidental absence of:

- (6) a) **v**: * [+labial, +voice] / [+continuant, -sonorant ____]
 b) **y**: * [+dorsal, +voice] / [+continuant, -sonorant ____]
 c) **dz**: * [+anterior, +voice] / [-cont. | +cont., ____]
 d) **dʃ**: * [-anterior, +voice] / [-cont. | +cont., ____]

If the auxiliary filters in (6) played a role in determining underspecification, the redundancy principle of 2.3 in conjunction with principle 3 of 2.3 would predict that the feature [-voice] is underlyingly unspecified in the feature bundles of /f, x, ts, tʃ/. Therefore, the underlying specifications for the feature [voice] of the Russian consonants would be those in (7):

(7)	p	t	k	b	d	g	ts	tʃ	f	s	ʃ	x	z	ʒ	m	n	l	r	w	y
sonorant	-	-	-	-	-	-	-	-	-	-	-	-	-	-	+	+	+	+	+	+
continuant	-	-	-	-	-	-	- +	- +	+	+	+	+	+	+	-	-	-	+	+	+
voice	-	-	-	+	+	+					-	-	+	+						

However, there is clear evidence that Russian consonants are underlyingly specified for the feature [voice] as in (5), not as in (7). We find this evidence if we consider Russian voicing assimilation.

In Russian, all members of an obstruent cluster assimilate in voicing to the last obstruent word-internally as well as across words. A case of word-internal voicing assimilation is illustrated in (8)a), and a case of word-sequence voicing assimilation is illustrated in (8)b), with the prepositions ot 'from' and bez 'without', which contrast in voicing before vowels, but lose this contrast before obstruents:

(8) a) gorod+k+a --> gorotka 'little town'

b) ot+ozera 'from a lake' bez+ozera 'without a lake'

ot <u>strasti</u>	'from passion'	bez <u>strasti</u>	'without passion'
ot <u>Pragi</u>	'from Prague'	bez <u>Pragi</u>	'without Prague'
ot <u>ptits</u>	'from birds'	bez <u>ptits</u>	'without birds'
od <u>banka</u>	'from a bank'	bez <u>banka</u>	'without a bank'
od <u>grexa</u>	'from a sin'	bez <u>grexa</u>	'without a sin'
od <u>bdenija</u>	'from a vigil'	bez <u>bdenija</u>	'without a vigil'

Sonorant consonants do not trigger voicing assimilation, as illustrated in the forms in (9):

(9)	pes <u>n</u> '	'song'	tr <u>i</u>	'three'	trav <u>a</u>	'grass'
	ziz <u>n</u> '	'life'			drov <u>a</u>	'wood'

Furthermore, sonorant consonants allow voicing assimilation to apply across them. In other words, they are transparent to voicing assimilation, as we can see in (10):

(10)	ot <u>n</u> ravov	'from morals'	bez <u>n</u> ravov	'without morals'
	ot <u>M</u> tsenska	'from Mtsensk'	bez <u>M</u> tsenska	'without Mtsensk'
	ot <u>m</u> stitel'nosti	'from	bez <u>m</u> stitel'nosti	'without
		vindictivness'		vindictivness'
	od <u>m</u> gli	'from fog'	bez <u>m</u> gli	'without fog'
	od <u>l</u> guni	'from the liar'	bez <u>l</u> guni	'without the liar'

I discuss the behavior of surface [v] derived from underlying /w/ in the Appendix to this section.

In Russian there is a rule which devoices consonants in word-final position. This rule applies to obstruents, but not to sonorants. Final devoicing feeds voicing assimilation. These facts are illustrated in (11):

- (11) zvezda 'star' tolsta 'stout' zizn'i 'life' misl'i 'thought'
 zvest tolst zizn' misl'

I hypothesize the following analysis of Russian voicing (I adopt some parts of the analysis proposed by Kiparsky (1985)).

I assume that the rule of voicing assimilation is the following:

- (12) X .. W.. X where w must not contain a
 root root syllabic peak.
 | |
 laryng. laryng.
 | |
 ≠ |
 α voice β voice (12) applies right to left

The condition on the content of the variable w constrains the application of the rule in the following way: the rule applies if (i) the two consonants are in the same rime, or (ii) the two consonants are in the same onset, or (iii) the consonant on the right is the onset and the consonant on the left is the rime of the immediately preceding syllable.

I assume that (12) applies iteratively by spreading and delinking at each step.

With rule (12), it is possible to account for cases like [bes ptits] and [od bdeniya]. These two word sequences are underlyingly represented as in (13): (I consider only the [voice] tier.)

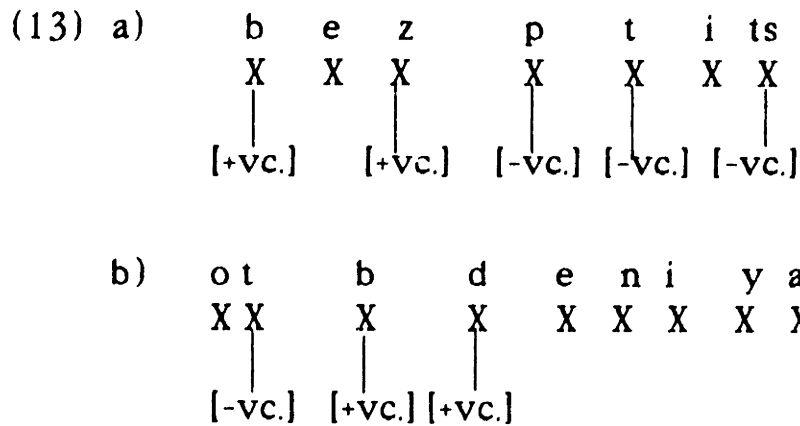

Rule (13) can apply only in the sequences [z pt], [t bd], in which the consonants are not separated by any syllabic peak. Therefore, (13)a) and b) are changed into (14) a) and b), respectively, which are the correct forms:

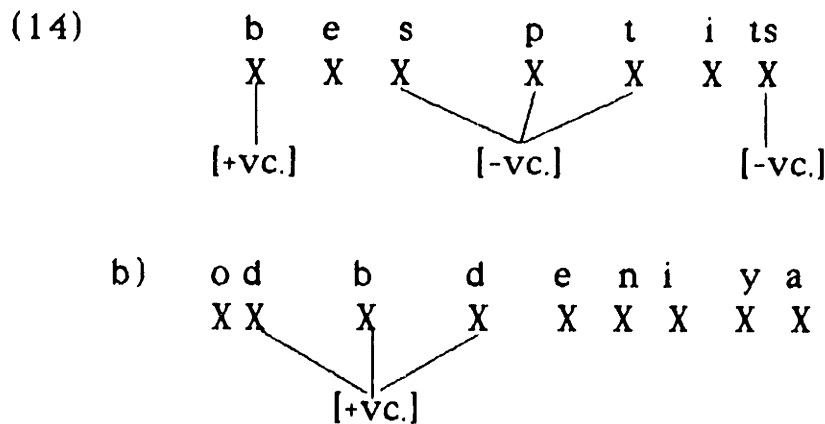

In this way, the forms [bes ptits] and [od bdeniya] are accounted for.

Let us consider final devoicing. I propose that the rule of final devoicing is the following:

$$(15) [a \text{ voice}] \quad \rightarrow \quad [-\text{voice}] / \quad \begin{array}{c} \text{X} \quad \#\# \\ \downarrow \\ \text{---} \end{array}$$

The rule of final devoicing must precede the rule of voicing assimilation, as we have seen in (11). In this way, we can explain a case like [zvest] of (11). [zvest] is underlyingly represented as in (16):

$$(16) \begin{array}{cccccc} z & v & e & z & d & \\ X & X & X & X & X & \#\# \\ | & & & | & | & \\ [+ \text{ voice}] & & & [+ \text{ voice}] & [+ \text{ voice}] & \end{array}$$

By the rule of final devoicing (16) is changed into (17):

$$(17) \begin{array}{cccccc} z & v & e & z & t & \\ X & X & X & X & X & \#\# \\ | & & & | & | & \\ [+ \text{ voice}] & & & [+ \text{ voice}] & [- \text{ voice}] & \end{array}$$

At this point, the voicing assimilation rule applies and we obtain (18)^[9]:

$$(18) \begin{array}{cccccc} z & v & e & s & t & \\ X & X & X & X & X & \#\# \\ | & & & \diagdown & / & \\ [+ \text{ voice}] & & & [- \text{ voice}] & & \end{array}$$

Let us now consider the sonorants. I assume that rule (12) and rule (15) apply before the redundancy rule of Chapter 2, Section 3 applies to fill in the underlyingly unspecified values. Therefore, when (12) and (15) apply, the feature value [+voice] is unspecified in the feature bundles of sonorants. In this way, it is possible to explain the behavior of sonorants with respect to voicing assimilation straightforwardly.

The fact that sonorants cannot be triggers of (12) is easily accounted for since sonorants do not have a feature value for [voice] when (12) applies.

The fact that sonorants are not affected by the voicing assimilation rule and by the final devoicing rule is accounted for by principle 1.6.(1). Recall that principle 1.6.(1) blocks the application of a rule to a feature bundle if this rule cannot fill in a feature unspecified in this feature bundle with a value that would create a disallowed configuration in this feature bundle. This is what would happen in the case of sonorants if the voice assimilation rule spreads the feature [-voice] onto it. In fact, this feature value would create the disallowed configuration [+sonorant, -voice]. Therefore, if the rule spreads [-voice], its application to the feature bundle of sonorants is blocked. If the rule spreads [+voice], the rule can apply to the feature bundle of sonorants, since no disallowed configuration would be created in this case. In this way, sonorants receive the feature value [+voice] and can be triggers of the voicing assimilation rule. At the same time, given that sonorants do not have a feature value on the tier on which the spreading of [voice]

In the case of [od lguni], we have the underlying representations in (21):

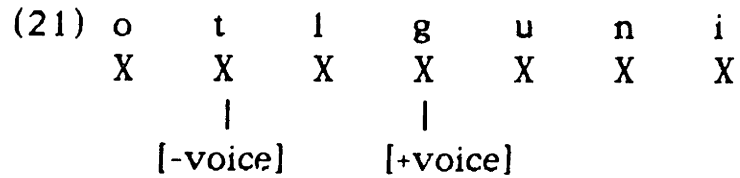

In (21), the voicing assimilation rule spreads the feature [+voice]. Therefore, according to principle 1.6.(1), it can apply to the sonorant /l/. In this way, /l/ receives the feature value [+voice] and is a trigger of the voicing assimilation rule. Therefore, we have the derivation in (22):

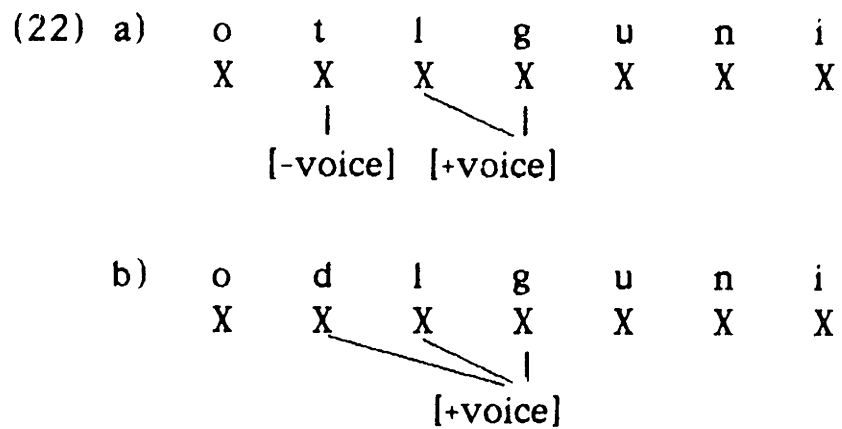

In the case of [ʒizn'], we have the underlying representation in (23):

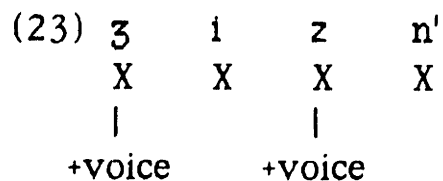

The final devoicing rule cannot apply in (23). By principle 1.6.(1), it cannot apply to the sonorant, since its application would create the disallowed configuration [+sonorant, -voice] in the feature bundle of the sonorant. It cannot apply to the obstruent /z/ either, because it is not in word-final position. Thus /zizn'/ will surface unchanged.

By assuming that sonorants are unspecified for the feature [voice] and that rules (12) and (15) apply before the redundancy rule fills in the unspecified features values, I account for the Russian facts very straightforwardly.[10]

The fact that the feature [+voice] is underlyingly unspecified in the feature bundle of the sonorants in Russian is predicted by the UG filter *[+sonorant, -voice], which is underlying in this language. Now, if auxiliary filters were to play a role in determining underspecification, we would expect that in Russian, the segments that are predicted to be underlyingly unspecified by the auxiliary filters of this language should behave as the sonorants do with respect to voicing assimilation. In (7), we saw that /f, ts, tʃ, x/ are the segments of the consonantal inventory of Russian which should be unspecified for the feature [voice], according to the auxiliary filters that hold in this inventory. We should then expect that /f, ts, tʃ, x/ behave as sonorants do with respect to voicing assimilation. In particular, they should not trigger the voicing assimilation rule, since they should not have a value for the feature [voice] when this rule applies. However, this is not correct. /f, ts, tʃ, x/ behave like all other obstruents and trigger voicing assimilation,

specifically spreading of [-voice], as we can see in (24):

(24)	bes forsa	'without a swagger'
	bes xleba	'without bread'
	bes tseni	'without price'
	bes tʃesti	'withot honor'

From (24), it is clear that /f/, /ts/, /tʃ/ and /x/ are underlyingly specified as [-voice], as is predicted by the pattern of underlying specification in (5) derived by considering only UG filters. Therefore, we may conclude that auxiliary filters do not play any role in establishing underspecification.

As a final point, I must note that the auxiliary filters (6)a) - d) are violated without any problem by the application of the voicing assimilation rule, as we can see in (25) for the case of /tʃ/. Recall that the fact that the voiced counterparts of /ts, tʃ, x/ may appear under voicing assimilation represented the core of the argument by Halle (1959) against autonomous phonemics:

(25)	a)	m'ok l _i	b)	m'og b _i
		"was (he) getting wet?"		"were (he) getting wet?"
	a)	ʒetʃ l _i	b)	ʒedʒ b _i
		"should (one) burn?"		"were one to burn?"

I believe that auxiliary filters tend to be easily violated by rules and actually eliminated from grammars. This is due to their intrinsic complexity, which derives from the fact that they are acquired through exposure to negative evidence. This is the case of Russian. I thus believe that cases like those discussed in Section 3 where auxiliary filters can actively trigger the application of clean up rules must be considered to be exceptions.

APPENDIX, SECTION 4

In this Appendix, I shall examine the behavior of the voiced labial fricative v in the consonantal inventory of Russian. In doing so, I shall discuss some of the differences that exist between my analysis of Russian voicing assimilation and the most recent analyses of the same phenomenon by Kiparsky (1985) and Hayes (1984).

The voiced labial fricative v has very interesting properties: it acts like an obstruent since it appears as the voiceless f in final word position and before a voiceless obstruent, but it also acts like a sonorant since it cannot be a trigger of the voicing assimilation rule. The properties of /v/ are illustrated in the following examples:

- (1) a) jazva "wound" trezva "sober" xorugv'i "banner"
 jazf trezf xorugf'
- b) tvoj 'your' ot vas 'from you'
 dva 'two' bez vas 'without you'
- c) korov + ka --> korofka 'little cow'
- d) ot vdov+y --> od vdovy 'from the window'
 ot vtor+ogo --> ot ftorogo 'from another'

The phonology of Russian independently motivates deriving v from an

underlying glide /w/ (Jakobson (1948), Halle (1973)). For example, Halle and Vergnaud (1981) observe that glides are deleted before consonants in the verbal conjugation, whereas obstruents are preserved:

- 2) znaj-u 'I know' nes-u 'I carry'
 zna-la 'I know' f.s. nes-la 'carried'

v patterns with the glides:

- 3) ziv-u 'I live'
 zi-la 'lived(f.s.)'

Therefore, one must postulate a rule which changes the underlying glide /w/ into the labial fricative [v]. This rule is formulated in 4):

- 4) -consonantal --> -sonorant / [-syllabic, ____]
 labial

where [-syllabic, ____] represents the fact that the rule applies only in the syllable margin, and not in the syllabic nucleus, so that it does not affect the vowel /u/.

Hayes's (1984) main proposal concerning voicing assimilation is to explain the transparency of sonorant with respect to voicing

assimilation by assuming that sonorants do undergo voicing assimilation and final devoicing. According to Hayes, the reason why they do not show assimilation is that the phonetic interpretation of the feature [voice] in terms of vocal cord vibration is different in obstruents and sonorants: in particular, the articulatory state which produces voicelessness in obstruents produces voicing in sonorants. This would explain why sonorants surface as voiced, despite the fact that they receive the feature [-voice] by voicing assimilation and final devoicing. In this way, the behavior of y is explained quite easily. The underlying glide /w/ receives the feature [-voice] like all of the sonorants when it is in the environment of a voiceless obstruent or in final word position. Given that it becomes a non-sonorant by rule (5), the feature [-voice] which it receives in the environment of a voiceless consonant and in word final position cannot correspond to vocal cord vibration, as would have happened if it remained a sonorant. Therefore, it surfaces as voiceless f.

There are two problems with Hayes' analysis. The first is that of explaining why sonorants do not trigger the voicing assimilation rule, although they undergo it. Hayes is forced to stipulate that only obstruents can trigger it.

The second problem concerns a fact that Hayes uses as evidence for his idea that sonorants do undergo voicing assimilation and final devoicing. In fast speech, voiceless sonorants do optionally appear before a voiceless obstruent and in word final position, as we can see in the following examples:

(5) rta [ɣt] 'mouth' mysl [sʲ] 'thought'

kontrfors [ɣfoɣs] 'buttress'

But why then can the same glottal configuration which is associated with vocal cord vibration in sonorants in lento speech be phonetically associated with lack of vocal cord vibration in fast speech? If it is just a problem of articulatory adjustment of the larynx, we would expect that voiceless sonorants also appear in lento speech, given that voicing assimilation and final devoicing should also apply to sonorants in lento speech. As far as I know, this is not correct: voiceless sonorants do not appear in lento speech.

Kiparsky (1985) solves the first of the two preceding problems. He proposes that sonorants are underlyingly unspecified for the feature [voice] and that the rule of voicing assimilation applies before the sonorants are specified as [+voice]. The consequence of this is that sonorants cannot be the trigger of voicing assimilation, which is thus sensitive only to the value for [voice] of the obstruents. Kiparsky uses Structure Preservation (see Chapter 1, Section 11) to explain why sonorants cannot be the target of voicing assimilation and final devoicing in word-internal ("lexical") phonology. In this way, he explains why final devoicing is blocked in zdorov-li (underlyingly [[zdorowU]-li]-- the jer falls before final devoicing applies--), but not in rat-li (underlyingly [[radU]-li]). According to Kiparsky, in word-

sequence ("post-lexical") phonology, Structure Preservation no longer holds. Therefore, at this stage, voicing assimilation and final devoicing can apply to sonorants and devoice them. Kiparsky therefore assumes that all of the instances of \underline{f} derived from underlying /w/ are produced by word-sequence ("post-lexical") application of voicing assimilation and final devoicing.

Observe now that by doing this, Kiparsky arbitrarily puts together what happens in *lento* and fast speech. According to Kiparsky's proposal, we should have voiceless sonorants in word-sequence phonology independently of the rate of speech. But, this is not correct. As far as I understand the literature, all of the examples reported in which sonorants do not undergo voicing assimilation belong to *lento* speech. Devoiced sonorants, in contrast, may appear only in fast speech, as pointed out by Hayes. Kiparsky cannot explain this, given that what is important for him is only the distinction between word-internal ("lexical") and word-sequence ("post-lexical") phonology.

I will propose a different approach to explain the behavior of [v] and the appearance of voiceless consonants.

First of all, I assume the analysis of voicing assimilation proposed in this section. I then propose that devoicing of sonorants results from a rule different from the voicing assimilation rule and the final devoicing rule. As a matter of fact, Avanesov (1972) (quoted by Kiparsky (1985)) observes that in fast speech sonorants can be voiceless only when they are adjacent to a voiceless consonant, regardless of whether they are on

the right or the left of this consonant, as in [ɾt]a, my[sɿ], kon[ɾfɔɾs]. They are not voiceless in final word position. Thus /l/ in /byl/ is not voiceless. This is clear evidence that sonorants are not affected by the same rules which affect obstruents.

I assume that the rule which devoices sonorants is the following:

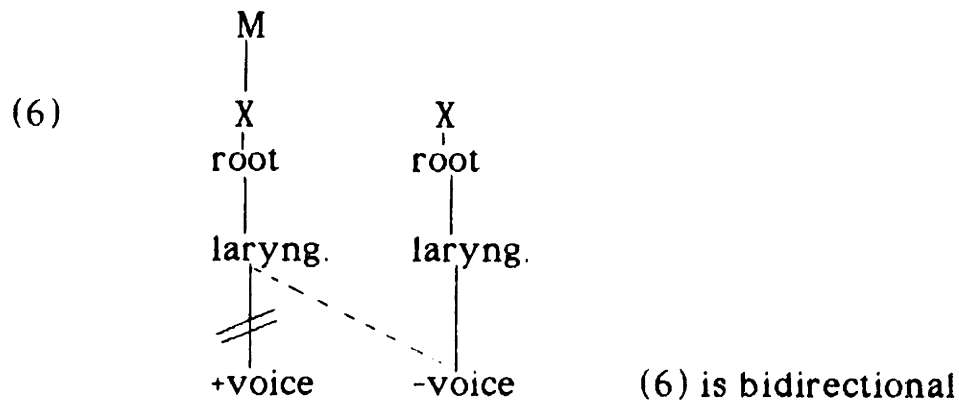

(with M I indicate the fact that the target of the rule must belong to the margin of a syllable, and not to the syllabic nucleus)

Rule (6) applies after the Redundancy rule (4) of Chapter 2, Section 3 has filled in the feature value [+voice].

Rule (6) applies after the rule of voicing assimilation has applied. Therefore, in rule (6) we do not need to specify that the target of the rule must be a sonorant since the only situations in which we find a sequence of a voiced segment and a voiceless segment adjacent to each other can be created by the Redundancy rule which fills in sonorants with [+voice]. In fact, the rule of voicing assimilation has eliminated all

other situations in which there are sequences of voiced and voiceless segments.

In (7), I give examples of application of (6) in the case of the forms rta and msl:



The application of (6) creates the configuration [+sonorant, -voice] disallowed by the UG filter *[+sonorant, -voice] which is underlying in Russian.

I assume that the configuration [-sonorant, -voice] must be repaired in lento speech. I hypothesize that the clean up rule which is used to repair this configuration is delinking of [-voice]. Therefore, in lento speech, the forms rta, msl' of (7) will surface unchanged. I then assume that in fast speech the configuration [+sonorant, -voice] is optionally either allowed to surface or repaired. Thus we can have [ɾt]a and mɬ[s]' , if it is allowed to surface, or [rt]a and mɬ[sl]', if it is repaired.

What about underlying /w/? I assume that the rule that changes /w/ into the non-sonorant [v] applies after the redundancy rule has filled in the feature [+voice] in sonorants, but before rule (6) applies. Therefore, we have the following derivation in the case of the

5 CHAIN SHIFTS.

In this highly speculative section, I will attempt to account for some cases of reorganization of a vowel system. Cases like these are analyzed as cases of "chain shifts" by structuralist linguists, i.e., as phonological changes, each of which in some way entails the next, because of the intrinsic properties of phonological systems. They are therefore used as evidence that the notion of phonological system must be considered a structural primitive, with the behavior of the individual elements composing it determined not just by their own content, but by their place in the system as well. I will propose that these cases of "chain shifts" can be accounted for in the framework proposed in this thesis by imposing restrictions on the use of auxiliary filters in the grammar.

I wish to propose that if a vowel system has one of the high vowels {i, u}, then it must also have the other high vowel. I obtain this in the following way. If there is a high vowel in a vowel system, this means that the UG filter *[+high, +syllabic] is underlyingly violated. If the UG filter *[+high, +syllabic] is underlyingly violated in a vowel system, then according to the UG filters, we expect that both /i/ and /u/ are present in this system. Therefore, the absence of one of these vowels can be expressed only by an auxiliary filter. I then propose the following principles:

- (1) No auxiliary filter can block a high vowel.

- (2) a) No unexpected absence of a segment in a phonological system is possible if it cannot be represented by an auxiliary filter.
- b) The absence of a segment is unexpected in a phonological system, if the UG filters violated in S predict its presence.

By (1) and (2), if there is one of the high vowels /i, u/ in a vowel system, then the other high vowel must also be present in this system.[11]

I will not try to derive principle (1) here, but I believe that it can be done. What I shall do instead is to examine the consequences of principles like (1) and (2).

First of all, I must solve a problem posed by principles (1) and (2). Several vocalic systems are reported in which /u/ seems to be absent. I believe that this is only superficially true and that all those systems actually have /u/ underlyingly. All of the systems which are reported to have /u/ absent have the vowel /o/. For example, there are several vowel systems like those in (3) and (4):

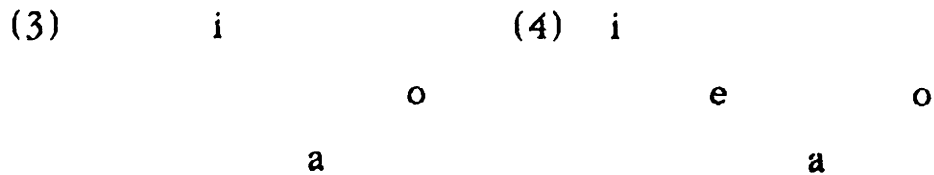

However in the phonetic description of languages with these vocalic systems, it is said that [u] actually occurs in the language and that it is an allophone of the mid back vowel. For example in discussing the vocalic system of the Philippine languages Reid (1973) observes that "*it is interesting to note that in phonemic descriptions of a number of languages (Bantoc, Cuyun^o, Iribaloi, Itneg (Binongan), Ivatan, Kankamay (Northern), Mananwa, Maranao and Sambal (Botolan) the back vowel has been represented by /o/ rather than /u/, reflecting the fact that although [u] does occur in some environment the lower variant [o] is more frequent and is considered the phonemic norm*" (Reid (1973 p. 490)

My proposal is that /u/ is underlyingly present in all of these languages, as predicted by the UG filters in conjunction with the principles (1) and (2), and that there is a surface rule which changes /u/ into /o/, i.e., rule (5):

$$(5) \quad \left[\begin{array}{c} +\text{high} \\ +\text{back} \\ +\text{round} \end{array} \right] > [-\text{high}]$$

Evidence for this hypothesis, I believe, lies in the fact that there are no vocalic systems like those in (6) or (7)(cf. Ferrari-Disner (1984))

:

(6)	i	(7)	i
	ɛ		e
	a		ɛ
			a

There is no way to explain the absence of the vowel systems in (6) and (7) unless we hypothesize that /u/ can be missing. If /u/ cannot be missing, then we immediately explain the absence of these kinds of systems.[12]

If what I am proposing is correct, a prediction can be drawn. If a context-free phonological change affects one of the vowels /i, u/, changing its feature bundle and therefore its identity, we get a system with an unacceptable gap. I propose that speakers cannot tolerate this situation, and that they will reorganize the system to avoid an unacceptable gap.

I believe that this is what happened in Old French. Old French had the vocalic system in (8):

(8)	i	u
	e	o
	ɛ	ɔ
	a	

Old French was characterized by a context-free phonological change by which /u/ was fronted. I will not discuss this very important phenomenon here. I shall represent this change with the following rule:

(9)	+high	+high
	+round	+round
	+back	-back

I hypothesize that context-free rules like that in (9) tend to result in a reorganization of the phonological system by which the segment or class of segments which is the target of the rule is eliminated from the underlying inventory. I suppose that this is what happened in Old French, so that the final effect of (9) was the elimination of /u/ from the vocalic system in (8), as we see in (10):

(10)	i	ü	
	e		o
	ɛ		ɔ
		a	

But principles (1) and (2) disallow a system like this. Therefore, something must be done to eliminate the disallowed situation in (10). I propose that UG provides the following means to solve the problem of a

disallowed gap like that in (10):

- (11) a) If a segment Z is absent in a system S, but its presence is required by (2), find a segment W in S with a feature bundle minimally distinct from that of Z and change it into Z.
- b) In a language L, a feature bundle F₁ is minimally distinct from a feature bundle F₂ in L if F₁ and F₂ are distinct but share the most number of features among the feature bundles in L.

By (2), a segment is required in a phonological system S if the UG filters violated in S predict its presence and there is no auxiliary filter to describe its absence.

(11) picks up the feature bundle of /o/ in (10), which is the feature bundle minimally distinct from that of the absent /u/ in (10), and changes it into this feature bundle. Thus we have the following phonological change:

(12) o --> u

(12) repairs the disallowed structure of (10) which is modified into asymmetric system in (13):

(13) i ü u
 e
 ε o
 a

The same kind of development of the vocalic system occurred in Ancient Greek, several northern Italian dialects and Portuguese. In all of them, there is the change /u -> ü/, and correlated to it the change /o -> u/. Observe that if my proposal is correct, I can explain the correlation between the two changes very easily: the change /o -> u/ is required in order to satisfy principles (1) and (2) which are violated by the context-free change /u -> ü/ which eliminates /u/ from the vocalic system. If my proposal is not correct, there is no other way to correlate the two changes, and the fact that they occur in the same diachronic development should be considered accidental. But this does not appear true, given that there has been the change /o -> u/ in all the languages in which there has been the change /u -> ü/.

Observe that the change /o -> u / cannot be the factor triggering the change /u -> ü/, simply because if the change /o -> u/ were to have applied first, there would have been a merging between the original /u/ and the /u/ from /o/. And therefore the change /u -> ü/ should have affected both /u/'s. This is not what happened.

I also propose that the low vowel /a/ must be always present in vowel systems. I have hypothesized that the UG filter *[+low, +syllabic]

must always be violated. According to the UG filters, the vowel which results from the violation of this filter is the low back vowel /a/. I propose that an auxiliary filter can never block a low vowel. I therefore modify (1) in the following way:

(14) No auxiliary filter can block a high vowel or a low vowel.

By (14) and (2), we can then expect that the vowel /a/ should always be present in every vowel system.

Martinet (1955) reports a context-free change of /a/ and a subsequent reorganization of the vocalic system in the French dialect of Hauteville. Martinet reconstructs the following vocalic system for an earlier stage of this dialect:

(15)

i	ü	u
e	ö	o
ɛ		
æ	a	

This vocalic system is found in several patois spoken around the town of Hauteville. In these patois /ɔ/ is often a contextual variant of /a/.

In Hauteville, however, a context-free rule changed all of the /a/'s into /ɔ/'s. Therefore, this rule eliminated /a/ from the vocalic system in (15). If nothing else had been done, we would have had the

system in (16):

(16)	i	ü	u
	e	ö	o
	ɛ		ɔ
	æ		

But (16) is excluded by principles (14) and (2) which require the presence of low back /a/. Therefore, (11) had to apply to repair this disallowed system. The feature bundle minimally distinct from that of /a/ in (19) is the feature bundle of /æ/. Therefore /æ/ was changed into /a/. In this way, we get the vocalic system in (17):

(17)	i	ü	u
	e	ö	o
	ɛ		ɔ
	a		

(17) is the vocalic system reported by Martinet for the contemporary dialect of Hauteville.

One might now object that there are languages with only one low vowel in which the low vowel is not back as predicted by the UG filters, but central or fronted. I assume that in these cases, the fronted or central low vowel is actually underlyingly back, as predicted by the UG filters, and that there is a rule of phonetic adjustment that fronts it. My

hypothesis is the that the low front vowel /æ/ is underlyingly possible in a certain vocalic system only if low back /ɑ/ is also present in that system.

FOOTNOTES CHAPTER 3

1. As can be observed in (1), I excludes that filters of the format in (i) are possible:

(i) $*[aF_1, bF_2, \dots cF_n]$

I therefore hypothesize that UG filters may only constrain the cooccurrence of two features in a feature bundle. If a third feature is needed to define the configuration disallowed by the UG filter, this feature must be in the environment of the filter. Therefore, UG filters may only have the format in (ii):

(ii) $*[aF_1, bF_2]/[_ , \dots cF_n]$

There are various reasons for this choice. First of all, the Redundancy Principle (2) of section 3, Chapter 2, requires that filters have the format in (ii) to make the correct predictions. If the filter had the format in (i) the Redundancy principle would give the wrong results. For example, consider the filter $*[+back, -round]/[_ , -low]$. Given this format, the Redundancy Principle correctly predicts that the feature [+round] is redundant in a feature bundle which underlyingly contains the feature [+back]. If this filter had the format $*[+back, -round, -low]$, the Redundancy Principle would incorrectly predict that the feature values [+round], [+low] are redundant in a feature bundle that

underlyingly contains [+back]. Secondly, fission requires that UG filters have the format in (ii) and not that in (i). Consider the same filter *[+back, -round]/[___ , -low]. Given this format, fission may correctly repair a configuration that violates it by creating two feature bundles with the configurations [+back, +round, -low], [-back, -round, -low]. If this filter actually had the format *[+back, -round, -low], we should expect that fission could repair a configuration that violates it by creating two feature bundles with configurations like [+low, +back, -round] [-low, -back, -round] or [+back, +round, -low] [-back, -round, +low], and so on. This is clearly incorrect.

2. If the filter *[-continuant, labial] is violated, we have a feature bundle that contains the feature [-continuant] and [labial] by principle (5) of the theory of underspecification discussed in Chapter 2, Section 3. In this feature bundle, the place node does not dominate any terminal feature values. This creates a situation of nontrivial underspecification. Given a system in which the UG filter *[-continuant, +round] are underlying, the redundancy rule in this case fills in the feature [-round]. Therefore, we will obtain the feature bundle of a labial unrounded stop. In a system, in which the filter *[-continuant, +round] is underlyingly violated, if a feature bundle contains the features [-continuant], [labial], but not the feature [+round], then it must be specified with the feature value [-round] by principle (6) of Chapter 2, Section 3. Therefore, in the same way as in the preceding system, we will have the feature bundle of a labial unrounded stop. Observe that in order to obtain this last case, principle (6) must be slightly modified in

the following way:

(i) Given a phonological system S, if the UG filter *[aF, bG] is underlyingly violated in S, a feature bundle that contains aF and the place feature that dominates the feature G, but not bG, will underlyingly contain -bG.

3. If the filter *[-continuant, dorsal] is violated, we have a feature bundle that contains the feature [-continuant] and [dorsal] by principle (5) of the theory of underspecification discussed in Chapter 2, Section 3. In this feature bundle, the place node does not dominate any terminal feature values. This creates a situation of nontrivial underspecification. Given a system in which the UG filters *[-continuant, -back], *[-continuant, -high], *[-continuant, +low] are underlying, the redundancy rule in this case fills in the features [+back], [+high], [-low] in this feature bundle. Therefore, we will obtain the feature bundle of a labial unrounded stop. In a system, in which the filters *[-continuant, -back], *[-continuant, -high], *[-continuant, +low] are underlyingly violated, if a feature bundle contains the features [-continuant], [labial], but not the features [-back], [-high], [+low], then it must be specified with the feature values [+back], [+high] and [-low] by principle (i) of note 2. Therefore, in the same way as in the preceding system, we will have the feature bundle of a labial unrounded stop.

4. I propose the following: dentality and alveolarity must not be directly connected to the features [+distributed] and [-distributed]. What [+/- distributed] really represents is the difference between apicality

and laminality. What I propose, however, is that dentality and alveolarity are connected to apicality and laminality in the following way: Anterior apical stops tend to be alveolar, but can also be dental. I hypothesize, however, that this correlation is essentially a matter of articulatory implementation in the sense that it does not play any significant linguistic role. The crucial linguistic distinction is that between laminality and apicality that is represented by the feature values + and - distributed. The difference between dentality and alveolarity is a matter of articulatory implementation of this more basic difference in the case of anterior consonants. I hypothesize the following rules of articulatory implementation:

- | | | | |
|---------|------------------------------|-----|----------|
| (62) | [+distributed, +anterior] | --> | dental |
| (63) a) | [-distributed, +anterior] | --> | alveolar |
| | b) [-distributed, +anterior] | --> | dental |

In the case of (63)a) and b), I assume that a language has the parametrical choice of adopting one of the two options. If a language adopts (63)a), it will have apico-alveolar consonants, if it adopts (63)b), it will have apico-dental consonants. I hypothesize that the rules of articulatory implementation belongs to the phonetics of a language, and therefore they do not have any linguistic role.

5. I adopted the feature [voice] in order to describe voicing essentially for reasons of expository simplicity. The features [stiff vocal cords], [slack vocal cords] proposed by Halle and Stevens (1979) could be used instead of [voice] in all of the filters I propose.

6. I assume that implosive stops are an articulatory implementation of voiced laryngealized stops. In particular I propose the following rule of articulatory implementation that can be adopted language specifically :

(i)	-continuant	--->	+laryngeal lowering
	+constricted glottis		(or +suction)
	+voice		

(i) states that voiced laryngealized stops can be implemented by making them implosive. This accounts for the fact that that laryngealized stops and implosive stops are never contrastive in the same language: implosive stops, if (i) is correct, are simply laryngealized stops implemented with implosion.

7.. I assume that auxiliary filters have the same format as UG filters: therefore only the cooccurrence of two features can be constrained by a auxiliary filter, and other features, needed to individuate the configuration of features peculiar to the segment accidentally absent, must belong to the context of the filter.

8 For reasons of simplicity, I omit an important step in this analysis of Bandjalang. The application of rule (10) to high vowels creates the configuration [-high, +ATR], which is disallowed by the UG filter *[-high, +ATR], which is underlying in this language. I assume that this configuration is repaired in all cases by delinking of [+ATR]. In this

way, we obtain the configuration [-high, -ATR] of a mid [-ATR] vowel like ɛ of Bandjalang.

9. Note that in order to explain cases like the following:

(i)	zvezda	'star'	tolsta	'stout'
	zvest	li	tolst	li
	zvest	to	tolst	to
	zvezd	ʒe	tolzd	ʒe

we must assume that the voice assimilation rule applies cyclically.

10. I must point out a problem observed by Jakobson (1956) and discussed by Halle-Vergnaud (1981). Sonorants in word final position are opaque, as we can see in the following examples:

(i)	ʒizn' i	'life'	misl' i	'thought'
	ʒizn'		misl'	
	ʒizn' li		misl' li	
	ʒizn' to		misl' to	
	ʒizn' ʒe		misl' ʒe	

The tentative solution that I propose to this problem is the following. I hypothesize that whereas sonorants can be incorporated in an onset in a position that violates the sonority hierarchy, as in mtsensk. This is not possible in the rime: a sonorant cannot be

incorporated in a rime in a position that violates the sonority hierarchy. I assume that if a sonorant cannot be incorporated in the rime, it is assigned a syllabic nucleus. Therefore, misl' must be syllabified in mis.l'. If this is correct, the rule of voicing assimilation cannot apply between the two c struents in (i) because of the intervening syllabic nucleus.

11. Observe that a vowel system with a high vowel like /i/ or /ü/, but not with /i, u/ is excluded by the ordering of UG filters in the UG filter hierarchy.

12. Trubetzkoy (1969) proposed that some Caucasian languages like Kabardian have the linear/vertical system /ə-e-a/, where the first vowel is high, the second mid and the third low. Allen (1956), Genko (1955) Kuipers (1960) clearly demonstrated that Trubetzkoy's analysis of the vowel system of these languages was not correct. See Section 12, Chapter 1 for analysis of the Kabardian vowel system.

FOOTNOTES CHAPTER 3

1. As can be observed in (1), I excludes that filters of the format in (i) are possible:

(i) $*[aF_1, bF_2, \dots cF_n]$

I therefore hypothesize that UG filters may only constrain the cooccurrence of two features in a feature bundle. If a third feature is needed to define the configuration disallowed by the UG filter, this feature must be in the environment of the filter. Therefore, UG filters may only have the format in (ii):

(ii) $*[aF_1, bF_2]/[_ , \dots cF_n]$

There are various reasons for this choice. First of all, the Redundancy Principle (2) of section 3, Chapter 2, requires that filters have the format in (ii) to make the correct predictions. If the filter had the format in (i) the Redundancy principle would give the wrong results. For example, consider the filter $*[+back, -round]/[_ , -low]$. Given this format, the Redundancy Principle correctly predicts that the feature [+round] is redundant in a feature bundle which underlyingly contains the feature [+back]. If this filter had the format $*[+back, -round, -low]$, the Redundancy Principle would incorrectly predict that the feature values [+round], [+low] are redundant in a feature bundle that

underlyingly contains [+back]. Secondly, fission requires that UG filters have the format in (ii) and not that in (i). Consider the same filter *[+back, -round]/[___ , -low]. Given this format, fission may correctly repair a configuration that violates it by creating two feature bundles with the configurations [+back, +round, -low], [-back, -round, -low]. If this filter actually had the format *[+back, -round, -low], we should expect that fission could repair a configuration that violates it by creating two feature bundles with configurations like [+low, +back, -round] [-low, -back, -round] or [+back, +round, -low] [-back, -round, +low], and so on. This is clearly incorrect.

2. If the filter *[-continuant, labial] is violated, we have a feature bundle that contains the feature [-continuant] and [labial] by principle (5) of the theory of underspecification discussed in Chapter 2, Section 3. In this feature bundle, the place node does not dominate any terminal feature values. This creates a situation of nontrivial underspecification. Given a system in which the UG filter *[-continuant, +round] are underlying, the redundancy rule in this case fills in the feature [-round]. Therefore, we will obtain the feature bundle of a labial unrounded stop. In a system, in which the filter *[-continuant, +round] is underlyingly violated, if a feature bundle contains the features [-continuant], [labial], but not the feature [+round], then it must be specified with the feature value [-round] by principle (6) of Chapter 2, Section 3. Therefore, in the same way as in the preceding system, we will have the feature bundle of a labial unrounded stop. Observe that in order to obtain this last case, principle (6) must be slightly modified in

the following way:

(i) Given a phonological system S, if the UG filter *[aF, bG] is underlyingly violated in S, a feature bundle that contains aF and the place feature that dominates the feature G, but not bG, will underlyingly contain -bG.

3. If the filter *[-continuant, dorsal] is violated, we have a feature bundle that contains the feature [-continuant] and [dorsal] by principle (5) of the theory of underspecification discussed in Chapter 2, Section 3. In this feature bundle, the place node does not dominate any terminal feature values. This creates a situation of nontrivial underspecification. Given a system in which the UG filters *[-continuant, -back], *[-continuant, -high], *[-continuant, +low] are underlying, the redundancy rule in this case fills in the features [+back], [+high], [-low] in this feature bundle. Therefore, we will obtain the feature bundle of a labial unrounded stop. In a system, in which the filters *[-continuant, -back], *[-continuant, -high], *[-continuant, +low] are underlyingly violated, if a feature bundle contains the features [-continuant], [labial], but not the features [-back], [-high], [+low], then it must be specified with the feature values [+back], [+high] and [-low] by principle (i) of note 2. Therefore, in the same way as in the preceding system, we will have the feature bundle of a labial unrounded stop.

4. I propose the following: dentality and alveolarity must not be directly connected to the features [+distributed] and [-distributed]. What [+/- distributed] really represents is the difference between apicality

and laminality. What I propose, however, is that dentality and alveolarity are connected to apicality and laminality in the following way: Anterior apical stops tend to be alveolar, but can also be dental. I hypothesize, however, that this correlation is essentially a matter of articulatory implementation in the sense that it does not play any significant linguistic role. The crucial linguistic distinction is that between laminality and apicality that is represented by the feature values + and - distributed. The difference between dentality and alveolarity is a matter of articulatory implementation of this more basic difference in the case of anterior consonants. I hypothesize the following rules of articulatory implementation:

- | | | | |
|---------|---------------------------|-----|----------|
| (62) | [+distributed, +anterior] | --> | dental |
| (63) a) | [-distributed, +anterior] | --> | alveolar |
| b) | [-distributed, +anterior] | --> | dental |

In the case of (63)a) and b), I assume that a language has the parametrical choice of adopting one of the two options. If a language adopts (63)a), it will have apico-alveolar consonants, if it adopts (63)b), it will have apico-dental consonants. I hypothesize that the rules of articulatory implementation belongs to the phonetics of a language, and therefore they do not have any linguistic role.

5. I adopted the feature [voice] in order to describe voicing essentially for reasons of expository simplicity. The features [stiff vocal cords], [slack vocal cords] proposed by Halle and Stevens (1979) could be used instead of [voice] in all of the filters I propose.

6. I assume that implosive stops are an articulatory implementation of voiced laryngealized stops. In particular I propose the following rule of articulatory implementation that can be adopted language specifically :

(i)	-continuant	---->	+laryngeal lowering
	+constricted glottis		(or +suction)
	+voice		

(i) states that voiced laryngealized stops can be implemented by making them implosive. This accounts for the fact that that laryngealized stops and implosive stops are never contrastive in the same language: implosive stops, if (i) is correct, are simply laryngealized stops implemented with implosion.

7.. I assume that auxiliary filters have the same format as UG filters: therefore only the cooccurrence of two features can be constrained by a auxiliary filter, and other features, needed to individuate the configuration of features peculiar to the segment accidentally absent, must belong to the context of the filter.

8 For reasons of simplicity, I omit an important step in this analysis of Bandjalang. The application of rule (10) to high vowels creates the configuration [-high, +ATR], which is disallowed by the UG filter *[-high, +ATR], which is underlying in this language. I assume that this configuration is repaired in all cases by delinking of [+ATR]. In this

way, we obtain the configuration [-high, -ATR] of a mid [-ATR] vowel like ɛ of Bandjalang.

9. Note that in order to explain cases like the following:

(i)	zvezda	'star'	tolsta	'stout'
	zvest	li	tolst	li
	zvest	to	tolst	to
	zvezd	ʒe	tolzd	ʒe

we must assume that the voice assimilation rule applies cyclically.

10. I must point out a problem observed by Jakobson (1956) and discussed by Halle-Vergnaud (1981). Sonorants in word final position are opaque, as we can see in the following examples:

(i)	ʒizn' i	'life'	misl' i	'thought'
	ʒizn'		misl'	
	ʒizn' li		misl' li	
	ʒizn' to		misl' to	
	ʒizn' ʒe		misl' ʒe	

The tentative solution that I propose to this problem is the following. I hypothesize that whereas sonorants can be incorporated in an onset in a position that violates the sonority hierarchy, as in mtsensk. This is not possible in the rime: a sonorant cannot be

incorporated in a rime in a position that violates the sonority hierarchy. I assume that if a sonorant cannot be incorporated in the rime, it is assigned a syllabic nucleus. Therefore, misl' must be syllabified in mis.l'. If this is correct, the rule of voicing assimilation cannot apply between the two obstruents in (i) because of the intervening syllabic nucleus.

11. Observe that a vowel system with a high vowel like /i/ or /ü/, but not with /ɪ, u/ is excluded by the ordering of UG filters in the UG filter hierarchy.

12. Trubetzkoy (1969) proposed that some Caucasian languages like Kabardian have the linear/vertical system /ə-e-a/, where the first vowel is high, the second mid and the third low. Allen (1956), Genko (1955) Kuipers (1960) clearly demonstrated that Trubetzkoy's analysis of the vowel system of these languages was not correct. See Section 12, Chapter 1 for analysis of the Kabardian vowel system.

CHAPTER IV

CLEAN UP RULES

In this chapter, I will present some arguments in support of the formalism that I adopted to represent clean up rules. In the case of the rules of fission and delinking, I will propose a slight modification of this formalism which allows a simplification of these rules. I shall begin by discussing the rule of fission.

1. FISSION.

Fission is a clean up strategy which repairs a configuration of feature values disallowed by a UG filter by sequencing the feature values composing this configuration. Thus, for example, the disallowed configuration [+round, -back] of the front rounded vowel /u/ is repaired in Italian by sequencing the feature values [+round] and [-back]. In this way, we obtain the diphthong [iu]. Thus, the feature values [+round] and [-back] which are articulated simultaneously in /u/ are articulated in succession in [iu]. In Chapter 1, Section 4, I proposed that this clean up strategy must be formalized as in (1): (Recall that in order to preserve the abstractness of the rule, I do not represent the internal structure of the feature bundles. Therefore the feature values aF1...dF4 that I use are actually nodes in the feature tree.)

(1)

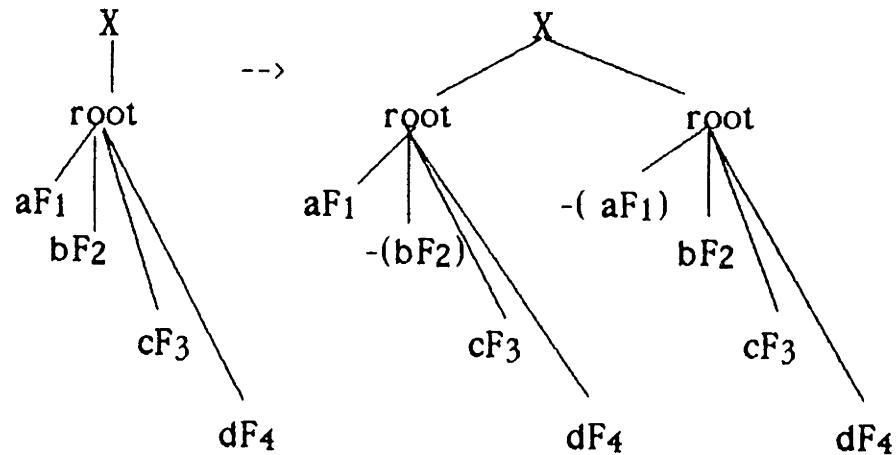

where the feature bundle on the left of the arrow contains the configuration of features $[aF_1, bF_2]$ disallowed by the filter $*[aF_1, bF_2]$ ($a, b, c, d = +/ -$).

As I said in Section 1.4, this rule operates in the following way: given a feature bundle B that contains a configuration of features disallowed by a UG filter, B is split into two copies which differs only in the features that compose the disallowed configuration. In fact, each copy contains one of the features of the disallowed configuration C matched with the opposite value of the other feature of C . This process does not affect the timing slot associated with the feature bundle that contained the disallowed configuration.

I proposed that the output of (1) is automatically simplified by a rule which merges adjacent identical nodes when dominated by the same timing unit. In this way, the output of (1) will automatically be changed into (2):

(2)

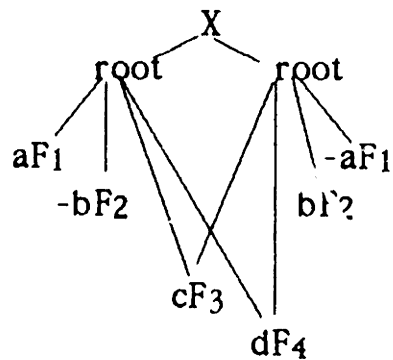

I will now discuss the reasons that led me to hypothesize that the clean up strategy of fission must be formalized as in (1). I will first discuss why I assume that the rule of fission in (1) does not affect the timing slot with which the feature bundle containing the disallowed configuration is associated. Then I will consider why I assume that the rule in (1) consists of the splitting of the feature bundle containing the disallowed configuration into two feature bundles.

I assume that the rule in (1) does not affect the timing slot with which the feature bundle containing the disallowed configuration is associated, because the rule of fission creates short diphthongs and affricates. There is evidence to say that the diphthong that we obtain by fission is a short diphthong, i.e., a diphthong which is associated with only one timing unit. The evidence comes from a southern Italian dialect, central Pugliese, where we have the same rule of metaphony that we find in other southern Italian dialects (cf. Section 1.5). In central Pugliese, we have lengthening of stressed vowels when they are in an open syllable and in penultimate position; long vowels are then always diphthongized into falling diphthongs (i.e., diphthong that have a glide as a second member); thus we have the following facts: (data from the dialect of

Trinitapoli (BA), Stehl (1980)) N.B. These are intermediate forms. To derive the surface forms we need a rule that turns unstressed nonlow vowels into schwa.

- (3) speina "thorn", aleiva "olive"
mais "month", grait@ "clay"
poide "foot", moil@ "honey"
koipe "head", nois "nose"
nouve "nine"
saule "sun"
noute "naked"

Note that vowels are short and not diphthongized in closed syllables:

- (4) cinge "five",
lengua "tongue", stedda "star"
sette "seven", pelle "skin"
vakka "cow"
fronte "forehead"
vokka "mouth"

But now observe that the metaphony rule can apply to vowels in closed syllables, and that the vowels are diphthongized if they are [-ATR] (the diphthongs obtained by metaphony are always rising diphthongs):

	sing.	Plur.	
(5)	dende	diendi	"tooth/teeth"
	masc.	fem.	
	gruossu	grossa	"big"
		cuorpu	"body"
		piettu	"breast"

In open syllables the diphthongs which are the outputs of metaphony are usually reduced to long high vowels:

(6)	poide	pi:di	"foot/feet"
	nouva	nu:vu	"new(fem.)/new(masc.)"

To explain the reduction of the diphthongs, we must suppose a stage with lengthening and diphthongization, as in pieiti, with later assimilation of the middle vowel.

It is clear from these facts that the rising diphthongs created by metaphony must be associated with only one timing slot like short vowels: they can occur in a closed syllable, and they are lengthened and diphthongized when in an open syllable.

Finally, note that there is no lengthening and diphthongization in stressed antepenultimate syllables. Consider the following words:

(7)	pekura	"sheep",	mɔnəkə	"monk (sing.)",	stɔməkə	"stomach"
-----	--------	----------	--------	-----------------	---------	-----------

As before, the diphthongs produced by metaphony can occur in this position:

- (8) *miɛdəkə* "physician"
muɔnəkə "monk(plur.)"

In Section 1.5, I argued that the diphthongization produced by metaphony must be considered to be an instance of fission used to repair the disallowed configuration created by the application of the metaphony rule to [-ATR] mid vowels. Now, in Pugliese, we have to say that diphthongs created by metaphony are associated with only one timing slot. The obvious consequence is then that the diphthongs created by fission are associated with only one timing slot.

I must then assume that fission consists of the splitting of a root node into two root nodes. The reasons for this are as follows: If the function of a clean up rule is that of repairing a configuration of features disallowed by a UG filter, it is obvious that the output of this rule cannot be blocked by the same UG filter. Now, UG filters constrain the cooccurrence of feature values. By definition, feature values cooccur when they are in the same feature bundle. Therefore, UG filters constrain feature values that are inside the same feature bundle. Recall that the effect of fission is that of sequencing the feature values of a configuration of features disallowed by a UG filter, instead of changing their values as the other clean up rules do. It is obvious, then, that

these feature values must be sequenced into two different feature bundles. If they were sequenced inside the same feature bundle, we would in fact still have the same disallowed configuration of features.

Now, by definition, a feature bundle consists of a group of features dominated by the same root node. Therefore, the feature values sequenced by fission must be dominated by two different root nodes. Let us consider, for example, the diphthong [iu] derived from /u/ by fission in Italian.

As I have discussed in Chapter 1, section 4, /u/ is disallowed in Italian because the features [+round] and [-back] cooccur in its feature bundle in violation of the UG filter *[+round, -back], which is underlying in Italian. /u/ has the feature bundle in (9):

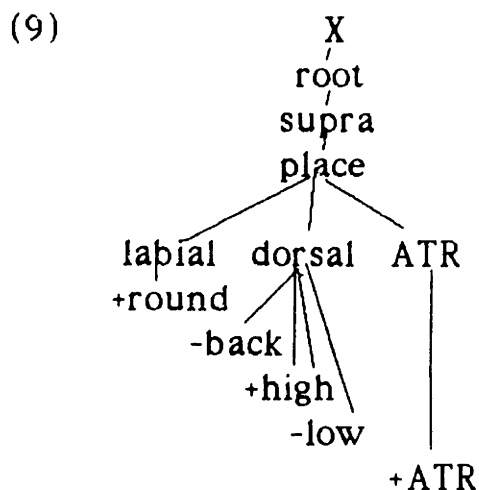

Given rule (1), the diphthong [iu] which is derived from /u/ should be represented as in (10):

(10)

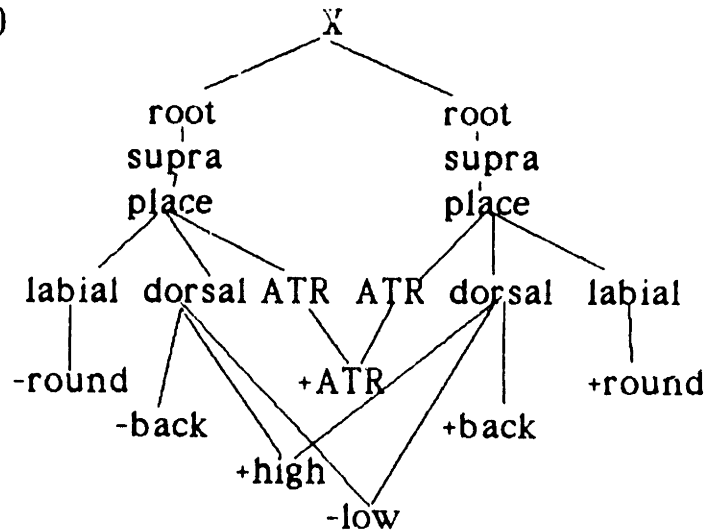

In (10), the feature values [+round] and [-back] are dominated by two different root nodes and therefore belong to different feature bundles. Thus, the UG filter *[+round, -back] is satisfied in (10).

Let us now suppose that fission does not affect the root node that dominates the disallowed configuration of features, i.e., let us suppose that it is not a rule like (1). The only alternative that we have in this case is to suppose that fission is a rule that creates sequences of terminal feature values. If this were correct, (9) would be changed into (11) by fission:

(11)

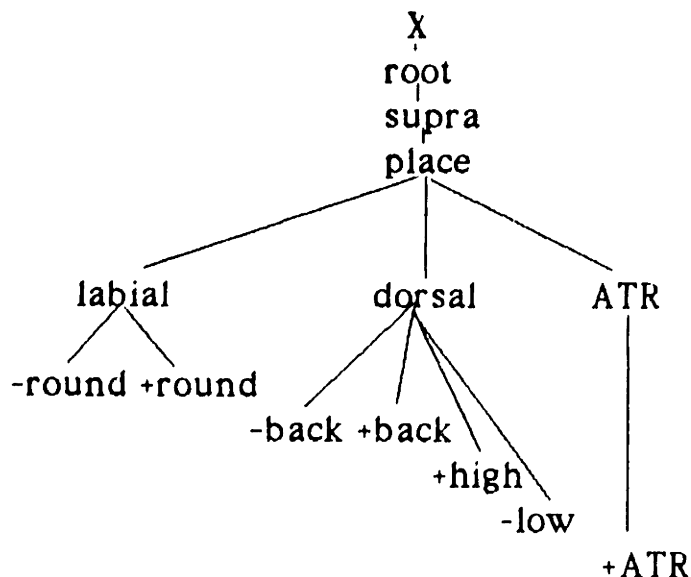

(11) would represent the diphthong [iu] that we obtain from /u/ in Italian.

The first problem to address in (11) is how to account for the fact that there is simultaneous articulation of the feature values [-round] and [-back] on one hand, and [+round] and [+back] on the other hand. In order to solve this problem, one could propose that the order of the branching terminal nodes overlaps in time, so that the first members of each branching terminal node are articulated simultaneously and then the second members are articulated simultaneously. However, regardless of the solution to this problem, (11) cannot be considered to be a repair of the disallowed configuration in (9) since [+round] and [-back] still cooccur in the same feature bundle; therefore, they still form a configuration disallowed by the filter *[+round, -back].

To answer the objection that (11) cannot be a repair of (9), one could hypothesize that UG filters are sensitive only to simultaneous articulation of features rather than to cooccurrence of features in the same feature bundle. In this way, there would not be any configuration in violation of the filter *[+round, -back] in (11), given that [+round], [-back] are not coarticulated simultaneously in (11). This would be a very interesting hypothesis to pursue. If it were correct, crucial importance would be given to the notion of coarticulation of features. UG filters would allow the coarticulation of certain features and disallow the coarticulation of other features. A possible segment in a language would then be represented by a set of features that can be coarticulated in L, given the UG filters that are underlying in L. Probably all of the results that I obtained in Chapter 1 could also be obtained by hypothesizing

that UG filters simply constrain the coarticulation of features. Formulating the theory of underspecification in these terms, however, would be more problematic. Coarticulation is a concrete phonetic notion that needs the positive presence of features to make sense. We can say that a given feature value can be underlyingly absent when its occurrence in a feature bundle is predicted by an underlying filter. But we cannot say that a feature value is underlyingly absent because it must be coarticulated with another feature value according to an underlying filter. This is what we would be forced to say if UG filters are defined as constraining the coarticulation of features, rather than the cooccurrence of features in a feature bundle. The point is that the notion of coarticulation is too concrete to account for an abstract phonological property such as underspecification. We need more abstract notions in order to do that. I believe that the notion of "cooccurrence in a feature bundle" is more correct. For these reasons and also for reasons of simplicity and clarity, I prefer to hypothesize that UG filters constrain the cooccurrence of features in a feature bundle. The notions of "feature bundle" and of "cooccurrence of features in a feature bundle" allow me to formulate clearer definitions and simpler statements of rules with respect to UG filters at this point in the development of my theory. However, the alternative theory of UG filters sketched in this paragraph is very interesting and is worth being pursued further.

Therefore, I believe that it is correct to represent fission as the rule (1).

The rule of fission in (1) can be simplified by eliminating one of its components. I propose that the component of (1) that matches each of the feature values of the disallowed configuration of features C with the opposite value of the other feature of C is not necessary. I then propose that the same effect obtained through this component can be derived by hypothesizing that the Redundancy rule 3.(4) of Chapter 2--repeated in (12)--may be applied as a "last resort rule" in order to fill in feature values that are left unspecified by preceding application of rules.

- (12) In a phonological system S, given an underlying filter $*[aF, bG]$ in S, assign $-bG$ in a feature bundle in S that contains aF .

Now, I propose that rule (1) can be stated as in (13):

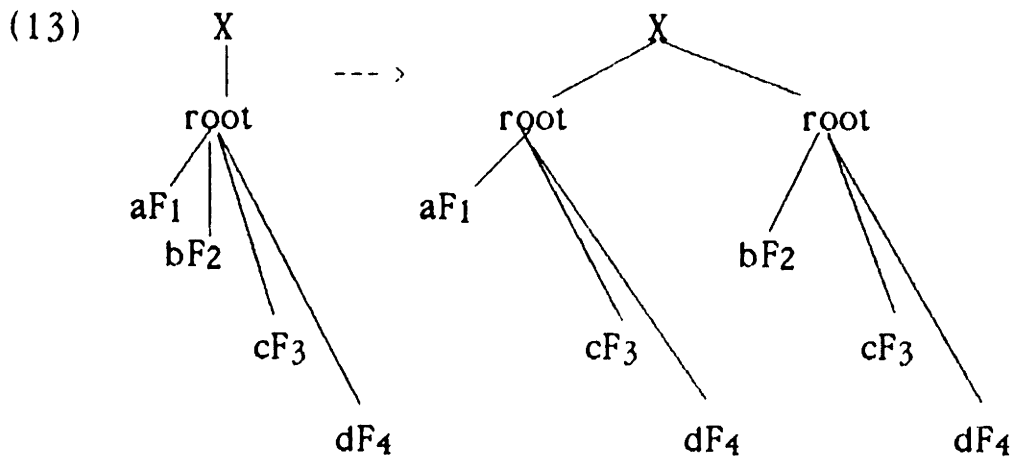

where the feature bundle on the left of the arrow contains the configuration of features $[aF_1, bF_2]$ disallowed by the filter $*[aF_1, bF_2]$ ($a, b, c, d = +/-$).

(13) is a rule that splits a feature bundle containing a disallowed configuration of features into two copies which differ in the fact that one of the copies has one of the features of the disallowed configuration and the other copy has the other feature. Each copy that is obtained in this way lacks a value for one of the features that composed the disallowed configuration. The problem is now to fill in this unspecified feature value. I propose that this unspecified value is filled in by rule (12). Therefore, given the underlying filter $*[aF1, bF2]$, rule (12) will fill in $[-bF2]$ in the feature bundle that contains $[aF1]$, but not $[bF2]$, and $[-aF1]$ in the feature bundle that contains $[bF2]$, but not $[aF1]$.

Let us consider the case of the Italian pronunciation of the German vowel /u/. Recall that the feature bundle of /u/ in (9) has the configuration of features $[+round, -back]$ disallowed in Italian by the underlying filter $*[+round, -back]$. Fission formulated as in (13) repairs this configuration by changing (9) into (14):

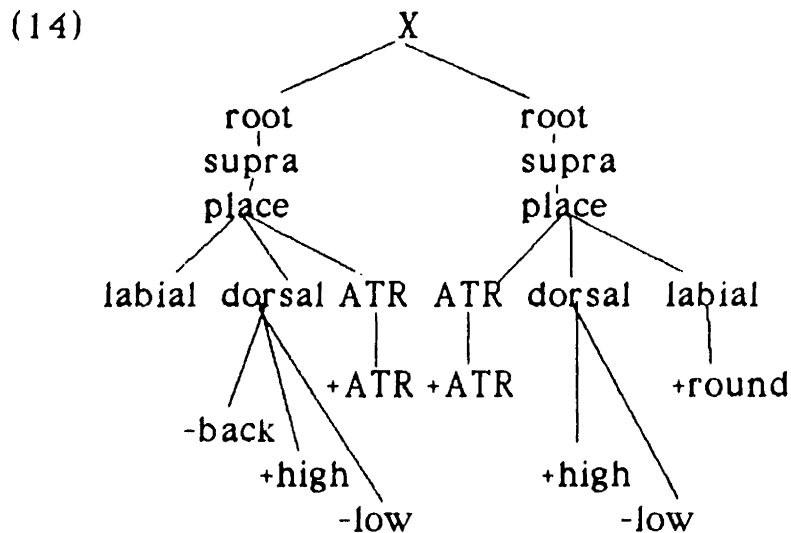

Now, the value for the feature $[round]$ is missing in the first

subsegment created by (13) in (14) ; in the second subsegment, instead, the value for the feature [back] is missing. If we apply (12) in (14) we will obtain the configurations [-back, -round] in the case of the first subsegment, and the configuration [+back, +round] in the case of the second subsegment. Therefore, (14) will be changed into (15) (merging of identical features is also applied in (15)):

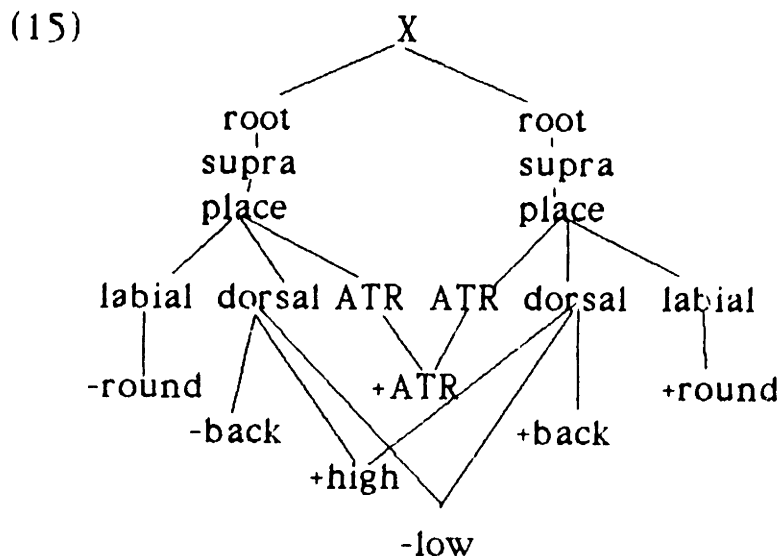

(15) is identical to the output of (1) in (10). Therefore, given the fact that (13) is simpler than (1), I hypothesize that (13) must be preferred over (1).

There are cases in which rule (13) produces a situation of trivial underspecification. This occurs when the disallowed configuration repaired by (13) contains a place feature. In these cases rule (12) obviously cannot fill in the values of the feature left unspecified by (13), since place features have only one value place that indicates the fact that they are present in the representation. I hypothesize that in

this case two different results can occur: (i) if the feature bundle without a place feature is the feature bundle of a phonetically possible segment, nothing needs to be done; (ii) if the feature bundle without the place node is not the feature bundle of a phonetically possible segment, then a "last resort" place feature is inserted.

The example that I use to illustrate the first case comes from Trubetzkoy (1969) and concerns Ukrainian. Ukrainian does not have the voiceless fricative /f/, although it has the voiced fricative /v/. In order to account for this situation, I hypothesize that Ukrainian has the following auxiliary filter:

(16) *[-voice, labial] / [+continuant, ____]

Now, the interesting fact, noted by Trubetzkoy is that the Ukrainians replace the /f/ of foreign words with the sequence [hv]. As Trubetzkoy puts it: "*[Ukrainians] interpret the simultaneous properties of f, that is voiceless friction and labiodental position of articulation, as two successive stages*" (Trubetzkoy (1969) p.64).

I propose the following explanation for the fact observed by Trubetzkoy. /f/ has the following feature bundle:

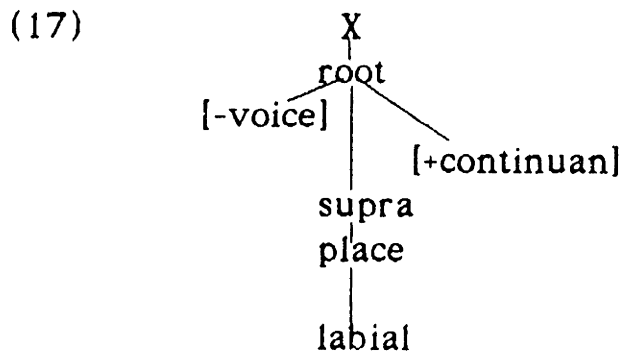

Given the auxiliary filter in (16), (17) is changed into (18) by the rule of fission in (13):

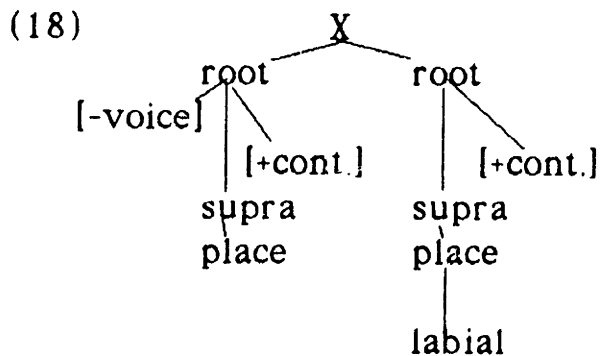

In (18), a value for the feature [labial] is missing in the left subsegment and a value for the feature [voice] is missing in the right subsegment. Now, the feature [voice] is non-trivially unspecified in the latter subsegment since it is a terminal feature that must be specified in that feature bundle. It is therefore filled in by a last resort application of (12). In contrast, the feature [labial] in the former subsegment is trivially unspecified since it is a place feature. Observe now that the feature bundle of this subsegment represents a phonetically possible segment, i.e., the segment [h]. Therefore, nothing needs to be done in this subsegment. Thus, (18) will be changed into (19) (merging of identical features is also applied in (19)):

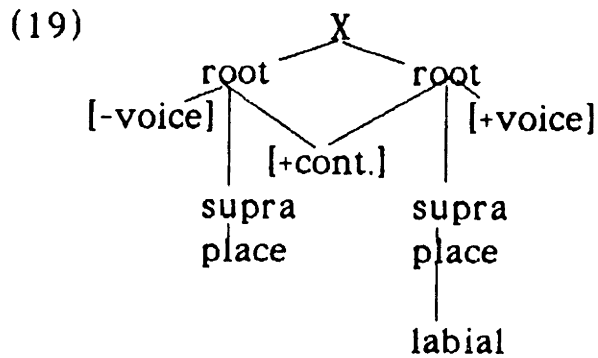

(19) represents the sequence [hv].

I now consider the case in which a "last resort" place feature must be inserted after application of the rule of fission in (13). Italian has the palatal nasal /ɲ/ and palatal lateral /ʎ/. In the framework I am proposing, this means that the UG filters *[+nasal, -back] and *[+lateral, -back] are underlyingly violated in Italian. Other European languages, German, for example, do not have the segments /ɲ/ and /ʎ/. This means that the two UG filters mentioned above are underlying in these languages. Now, when speakers of these languages speak Italian, they tend to replace the sounds /ɲ/ and /ʎ/ with the sequences [ny] and [ly]. Therefore, the standard Italian words /montaɲɲa/ 'mountain' and /voʎʎo/ 'I want' are pronounced [montannya] and [vollyo] by these speakers. I account for this phenomenon in the following way: in these languages, the UG filters *[+nasal, -back] , *[+lateral, -back] are underlying. Therefore, the feature bundles of Italian /ɲ/ and /ʎ/ in (20)a) -b) contain the disallowed configurations [+nasal, -back] and [+lateral, -back], respectively:

(20) a)

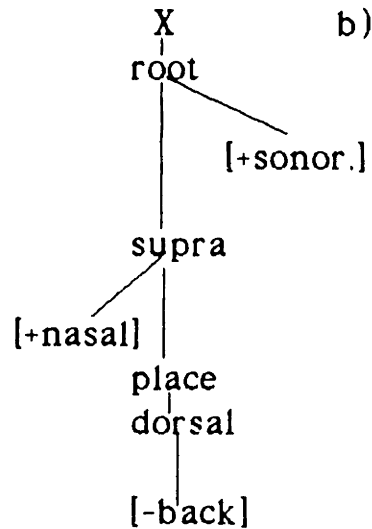

b)

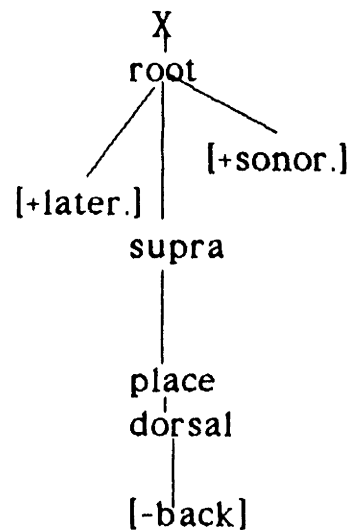

The rule of fission in (13) is applied to repair these disallowed configurations. Therefore, (20)a) and b) become (21)a) and b):

(21)

a)

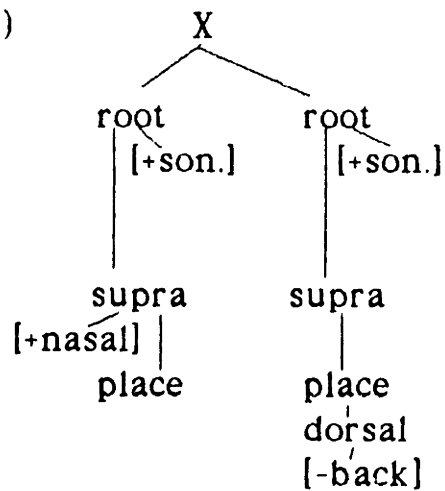

b)

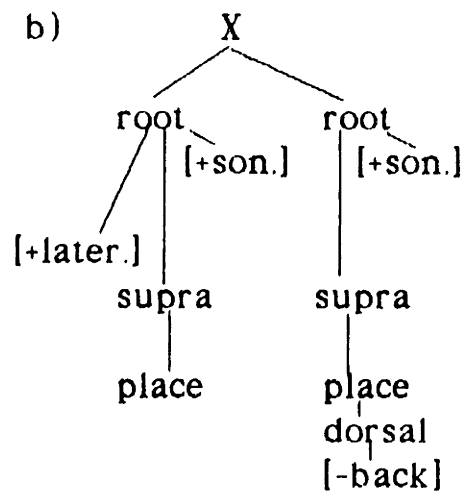

Now a feature bundle that contains the feature [+nasal] or the feature [+lateral] must also contain a place feature, since it is impossible to articulate a lateral or a nasal segment without an oral occlusion. Therefore a place feature is required in the feature bundles of the subsegments on the left in (21)a) and b).

and [ly] would be difficult to account for, if the rule of fission were that in (1). Therefore, I assume that (23) is the correct formulation of the rule of fission.

There is an important problem concerning the rule of fission that at this point in my research, I still cannot solve. Given the rule (23) (this, however, would also hold for rule (1)), how do I account for the order of the features in the sequence? I do not have any clear answer to this question.

In order to clarify this point, I give here a list of the repairs that I believe are effected by fission (I first list the relevant filters, then the repairs and finally the attested examples):

(26) a) * [round, -back]

u --> iu

in the Italian pronunciation of French and German u; in the Romanian pronunciation of French and Turkish words.

b) * [-round, back] / [-low, _]

ɨ --> ui

in the Lithuanian pronunciations of Russian ɨ; in the Finnish pronunciation of Russian ɨ.

c) * [+high, -ATR]

ɪ --> iɛ

in the metaphony in southern Italian dialects.

d) *[-conson. , +nasal]

ã --> an

in the elimination of nasal vowels in many languages.

f) *[+nasal, -back]

ɲ --> ny

in the foreign pronunciation of Italian.

g) *[+lateral, -back]

ɫ --> ly

in the foreign pronunciation of Italian.

h) *[-voice, labial]/[+cont.,___]

f --> hv

in the Ukrainian pronunciation of Russian f.

There appear to be certain regularities in (26), for example, the feature [back] is always in the first member of the sequence created by fission. According to Keyser, Stevens and Kawasaki (1984)'s theory of phonological enhancement, the feature [back] is the salient feature in the pair ([back], [round]). In fact, [round] tends to be used to enhance [back]. I could, therefore, propose that the first member of the sequence created by fission must be a salient feature in Keyser, Stevens and Kawasaki's sense (cf. Andersen(1972)) for a similar proposal in a different framework). This could be the correct solution given that the features [high], [continuant], [consonantal], [lateral], [nasal] could also be considered to be the salient features in the pairs ([high], [ATR]),

{[continuant, [distributed]], {[lateral], [back]], {[nasal], [back]], respectively. In this way, one can explain why those features occur as first members of the sequences in (26). I however doubt that the feature [voice] can be considered the salient feature in the pair {[voice], [labial]}. Therefore, the order of the features in the sequence in (26)h still needs to be accounted for. More research is needed on this point.

2.DELINKING.

Delinking is a clean up strategy by which a disallowed configuration of features is repaired by changing one of the features of this configuration. In section 4, Chapter 1 I formalized this repair as in (1) where delinking is analyzed as having two components: one that delinks one of the feature values blocked by a filter; the other that replaces the delinked feature value with its opposite value. I represent this in (1):

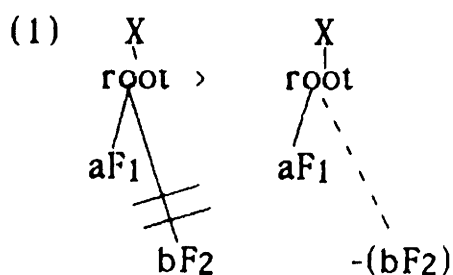

where aF₁ conflicts with bF₂ because of the filter *[aF₁, bF₂] (a,b - +/-)

Here, I will propose that the delinking rule in (1) can be simplified in the same way that the rule of fission was simplified in the preceding section. Thus I propose that the component of the delinking rule which inserts a feature value opposite to the one that is delinked can be eliminated. In this way, the delinking rule can be simply stated as in (2):

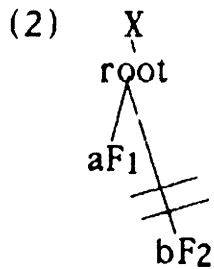

where aF1 conflicts with bF2 because of the filter *[aF1, bF2] (a,b - +/-)

I assume that the feature value delinked by (2) is deleted by convention.

I then propose that the unspecified value left by (2) is filled in by rule (12) of the preceding section.

Thus, for example, consider a case in which the configuration [+high, -ATR] is created by a phonological rule in a language where the UG filter *[+high, -ATR] is underlying. Let us suppose that this configuration in this language is repaired by delinking. Given (2), the repair would be as follows. Given the feature bundle of /ɪ/ with the disallowed configuration [+high, -ATR]:

(3)

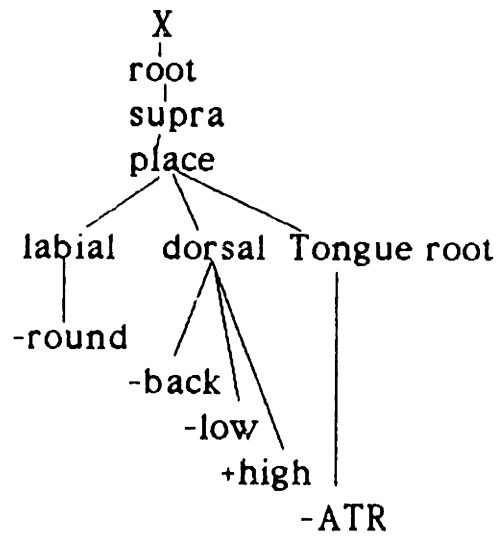

The delinking rule in (2) changes the feature bundles in (3) into the following feature bundle:

(4)

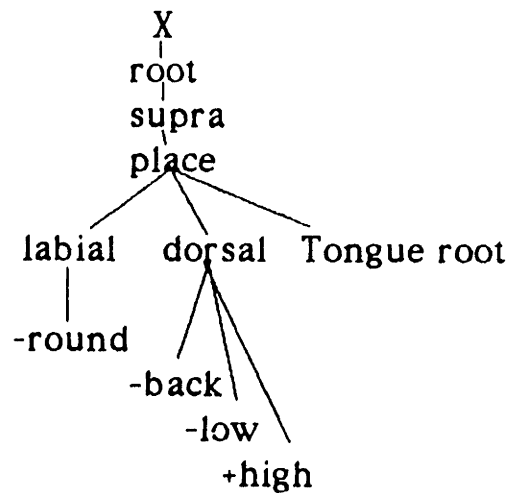

The unspecified value for [ATR] must be specified. It is specified by a last resort application of 1.(12). Therefore (4) is changed into (5):

(5)

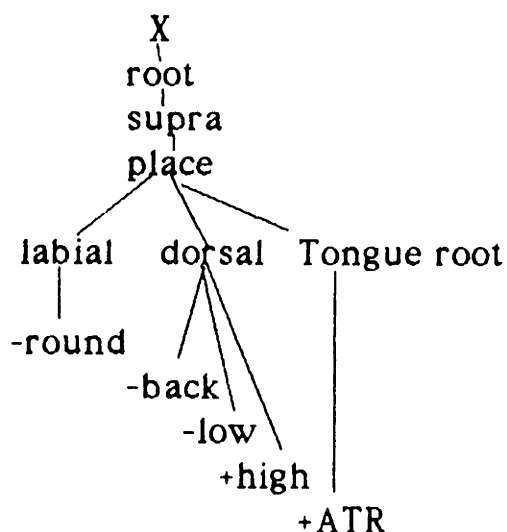

3.NEGATION

In Section 4, Chapter 1, I proposed that negation is a clean up strategy by which a disallowed configuration of features is repaired by negating the feature values of this disallowed configuration, so that each feature comes out with its opposite value. I formulated this as in (1):

$$(1) \quad [aF_1, bF_2] \rightarrow -([aF_1, bF_2]) \rightarrow [-aF_1, -bF_2]$$

where aF_1 and bF_2 are conflicting feature values because of the filter $*[aF_1, bF_2]$ ($a, b = +/-$)

I consider negation the most problematic of the clean up rules that I propose. Whereas delinking and fission may have a "natural" phonetic interpretation in a framework that does not use binary feature

values, negation relies heavily on binary feature values. Certainly, there is nothing incorrect in relying on binary feature values, however the point is that in this way negation acquires a very abstract status grounded only on theory-internal considerations.

The cases of repair that led me to hypothesize a clean up rule like negation are the following:

- (2) a) $\iota, \upsilon \rightarrow e, o$. (in the metaphonic alternation $\epsilon, \circ / e, o$ in several southern Italian dialects; in the surface merging of ι, υ with e, o in Okpe; in the diachronic changes from Proto-Kwa to the modern Kwa language; and in several other cases see in Chapter 1)
- b) $[+ATR] A \rightarrow \epsilon / \circ$ (in the diachronic changes from Proto-Kwa to the modern Kwa languages; in several $[+/- ATR]$ harmony systems in which the $[+ATR]$ counterpart of /a/ is either $\underline{\epsilon}$ or $\underline{\circ}$)
- c) $a+y, a+w \rightarrow \epsilon, \circ$ (in Kabardian and in many other languages like Sanskrit, for example)

Given the UG filters $*[+high, -ATR]$, $*[+low, +ATR]$ and $*[+low, +high]$, these cases of repair can be accounted for by negation in the following way:

(3) a) [+high, -ATR] --> -([+high, -ATR]) --> [-high, +ATR] (= (2)a)

b) [+low, +ATR] --> -([+low, +ATR]) --> [-low, -ATR] (= (2)b)

c) [+high, +low] --> -([+high, +low]) --> [-high, -low] (= (2)c)

In the course of my research I have not met other cases of repair that can be analyzed as instances of negation, except those in (2).

Observe that the disallowed configurations of the cases in (2) all involve features that define a degree of height (I assume that [ATR] defines a degree of height). Thus, the application of negation effects a change in degree of height of the segments that contain the disallowed configurations. At this stage of the development of the phonological theory, I do not have any other way of formulating this kind of repair than that proposed in (1) with the restriction that negation can be applied only when the disallowed configuration involves features that define a degree of height, i.e., [high], [low] and [ATR].

However, there is an important fact that must be pointed out. Traditional linguists have often observed that the changes in (2)a) and b) can be accounted for on the basis of acoustic similarity. For example, Weinrich (1958), as most other Romance philologists, explains the merging of the hypothesized Latin [-ATR] high vowels (open high vowels in his terminology) with [+ATR] mid-vowels (close mid-vowels in his terminology) by basing his analysis on the fact that these two classes of vowels are acoustically very similar. Given this similarity,

these two classes of vowels cannot be used for an efficient phonological contrast, according to Weinrich, and therefore they are merged. Regardless of the fact that this analysis is not very explanatory--the direction of the merging is not accounted for, for example--it reveals the importance that could be given to the acoustic similarity between [-ATR] high vowels and and [+ATR] mid vowel, acoustic similarity that indeed also exists between [+ATR] low vowels and [-ATR] mid vowels.

I could then propose that negation is not a repair strategy that affects the values of the features of a disallowed configuration of features, but a repair strategy that changes the feature bundle of a segment with a disallowed configuration of features into the feature bundle of an acoustically similar segment that does not have this disallowed configuration of features. Let us call this repair strategy acoustic transfer. In this way, the repairs in (2)a) and b) would be explained, without relying on negation of feature values. In this way, also the constraints on the kind of repairs seen in (2) would be explained: for example, acoustic transfer would not be able to change the disallowed configuration [+round, -back] into the configuration [-round, +back]. In fact, a segment that contains the former configuration of features is acoustically very different from a segment that contains the latter configuration of features.

If "negation" is actually acoustic transfer I cannot account for the repair in (2)c). The repair in (2)c) should then be treated by an independent rule. However, if "negation" is acoustic transfer, I can account for a phenomenon that otherwise cannot be explained in my

framework. This phenomenon is the replacement of /θ/ with /f/ that occurs in my pronunciation of English, for example, as in the pronunciation of English by other foreign speakers. A segment like /θ/ is disallowed by the UG filter *[+cont., -strid.]. The following replacements of /θ/ are reported besides the already mentioned /θ > f/:

- (4) a) θ > s
 b) θ > t

(4) a)-b) can be easily explained by delinking: (4)a) is a case of delinking [-strident] and (4)b) is a case of delinking of [+continuant]. However, the change /θ > f/ is much more problematic. It in fact involves a change in place of articulation in addition to a change in stridency. Let's consider the feature bundles of /θ/ and /f/:

- | | | | | |
|-----|----------|-----------|----------|-----------|
| (5) | a) /θ/ = | -sonor. | b) /f/ = | -sonor. |
| | | +cont. | | +cont. |
| | | +coron. | | +labial |
| | | -strident | | +strident |

The change from (5)a) to (5)b) cannot be an application of delinking or fission. It cannot be an application of negation either, since negation applies only to the features that are blocked by a filter and a filter like *[+coronal, -strident] is a nonsense. Given the features in (5)a), there is no other way of getting (5)b) by the clean up rules that I proposed.

Now, /f/ is indeed acoustically similar to /θ/. Therefore, if acoustic transfer were a valid clean up strategy, I would be able to account for the replacement of /θ/ with [f] straightforwardly.

At this stage of the development of my theory, however, I believe that endorsing acoustic transfer as a valid repair strategy is not a correct move. The notion of acoustic similarity is a very vague notion whose theoretical status does not appear to me very satisfying. Observe that if acoustic transfer were adopted as a possible clean up strategy, it would overlap with delinking and fission, since one can argue that the segments that are the output of fission and delinking are acoustically similar to the segments that were the input of these clean up rules. Only confusion would be created in this way. Until there is a formal definition of when two segments are phonetically similar or different, acoustic transfer cannot be adopted as a correct repair strategy. Therefore, I prefer to assume that negation is the correct way of accounting for the repairs in (2), even if this creates some problems, like the impossibility of explaining the repair /θ/ --> [f], for example. More research is indeed needed on this matter.

References

- AIS = Jaberg, K. and J. Jud (1928 - 1940) Sprach-und Sachatlas Italiens und der Sudschweiz, Zofingen: Ringier.
- Allen, W.S. (1956), "Structure and System in the Abaza Verbal Complex" in Transaction of the Philological Society ,1956, pp.127-176.
- Andersen, H. (1972), "Diphthongization" in Language , 48,1, pp.11-50.
- Anderson, S.R., "Syllabies, Segments and The North-West Caucasian Languages" in A.Bell and J.Hooper (eds.), Syllables and Segments, North Holland, pp. 57-89.
- Anderson, S.R. (1980), "Problems and Perspectives in the Description of Vowel Harmony" in R.M. Vago (ed.), Issues in Vowel Harmony, Amsterdam: John Benjamins B.V., pp.1-49.
- Aoki, H. (1966), "Nez Perce Vowel Harmony and Proto-Sahaptian Vowels" in Language, 42, pp.759-767.
- Archangeli, D., (1984), Underspecification in Yawelmani Phonology and Morphology, MIT Ph.D. Dissertation.
- Archangeli, D. and D. Pulleyblank, (1986), The Content and Structure of Phonological Representations, ms., University of Arizona and USC.
- Avanesov, R.I. (1972), Russkoe Literaturnoe Proiznošenie, Moscow: Učpedgiz.
- Block, B., (1950), "Studies in Colloquial Japanese IV: Phonemics" in Language, 26, pp. 86-125.
- Bogoraz, W., (1922), "Chukchi" in F. Boaz (ed.), Handbook of American Indian Languages, Washington, D.C, pp. 631-903.
- Calabrese, A.(1986) "Metaphony in Salentino" in Rivista di grammatica generativa, 9-10., pp.1-141.

- Campbell, L. (1980) "The Psychological and Sociological Reality of Finnish Vowel Harmony" in R. Vago (ed.) Issues in Vowel Harmony. Amsterdam: John Benjamins, pp. 245-270.
- Chomsky, N. and M. Halle (1968), The Sound Pattern of English, New York: Harper & Row.
- Clements, G.N. (1985), "The Geometry of Distictive Features" in The Phonology Yearbook, 2, pp.223-252.
- Clements, G.N. (1987), "Phonological Feature Representations and the Description of Intrusive Stops" in A. Bosch et Alii (eds.), Parasession on Autosegmental and Metrical Phonology. Chicago Linguistic Society, 23.
- Clements, G.N. and S.J. Keyser (1983) CV Phonology: a Generative Theory of the Syllable, Cambridge: MIT Press.
- Christdas, P. (1987), Cornell University Ph.D. Dissertation (in progress).
- Chumbow, S. (1982), "Ogori Vowel Harmony: an Autosegmental Perspective" in Linguistic Analysis, 10.1, pp.61-93.
- Colarusso, J. (1975), North-West Caucasian Languages: a Phonological Survey, Ph.D. Dissertation, Harvard University, Cambridge, Mass.
- Cole, J. (1987), Planar Phonology and Morphology, Ph.D. Dissertation, MIT. Cambridge, Mass.
- Cole, J., and L. Trigo (1987), "On the Representation of Neutral Segments in Harmony Systems", ms., MIT.
- Comrie, B. (1981), The Languages of the Soviet Union, Cambridge: Cambridge University Press.
- Crowley, T. (1978), The Middle Clarence Dialects of Bandjalang. Australian Institute of Aboriginal Studies, Canberra.
- Dell, F. (1973), Les Règles et les sons, Paris, Hermann.

- Farkas, D. and D. Beddor (1987), "Privative and Equipollent Backness in Hungarian, Chicago Linguistic Society, 23.
- Ferrari-Disner, S. (1984), "Insights on Vowel Spacing" In I. Maddieson, *Patterns of Sounds*, Cambridge: Cambridge University Press, pp. 136-155.
- Genko, A.N. (1955), Abazinskij jazyk, Moskow.
- Goldsmith, J. (1976), *Autosegmental Phonology*, Doctoral Dissertation, MIT, Cambridge, Mass. (published by Garland, New York, 1979.)
- Hall, B.L. and R.M.R. Hall (1980), "Nez Perce Vowel Harmony: an Africanist Explanation and some Theoretical Questions" in R.Vago (ed.) Issues in Vowel Harmony, Amsterdam: John Benjamins, pp. 201-236
- Halle, M. (1959) *The Sound Pattern of Russian*, The Hague: Mouton.
- Halle, M. (1962) "Phonology in a Generative Grammar", in *Word*, 18, pp. 54-72.
- Halle, M. (1970), "Is Kabardian a Vowel-less language?" in Foundations of Language, 6, pp. 95-103.
- Halle, M. (1973), "The Accentuation of Russian Words" in Language, 49, pp. 312-348.
- Halle, M. (1983), "On Distinctive Features and their Articulatory Implementation" In Natural Language & Linguistic Theory, 1, 1, pp. 91-106.
- Halle, M. (1986) "Speech Sounds and their Immanent Structure", ms., MIT, Cambridge, Mass.
- Halle, M. (1987) "Phonology" to appear in D. Osherson (ed.), An Invitation to Cognitive Science, Cambridge, Mass.: The MIT Press.
- Halle, M. and K.Stevens (1971), ' A Note on Laryngeal Features", Quarterly Progress Report, Research Laboratories of Eletronics,

MIT, 101, pp.198-213.

Halle, M. and J.R. Vergnaud (1980), "Three Dimensional Phonology" in Journal of Linguistic Research, 1, pp. 83-105.

Halle, M. and J.R. Vergnaud (1981), "Harmony Processes" in W. Klein and W. Levelt (eds.) Crossing the Boundaries in Linguistics. Studies presented to Manfred Bierwisch, Dordrecht: Reidel.

Haraguchi, S. (1984), "Some Tonal and Segmental Effects in Vowel Height in Japanese" in Aronoff, M. and R.T.Oehrle (eds.) Language, Sound, Structure, Cambridge: MIT Press, pp. 145-157.

Harris, J. (1969), Spanish Phonology, Cambridge: MIT Press.

Hasegawa, N. (1979) "Fast Speech vs. Casual Speech" in Clyne P.R., W.F. Hanks and C.L. Hofbauer (eds.), Chicago Linguistic Society 15, pp. 126-137.

Haudricourt, A.G. and A.G. Jullard (1949) Essai pour une histoire structurale du phonétisme français, Paris: Klincksieck.

Hayes, B. (1984), "The Phonetics and Phonology of Russian Voicing Assimilation" in Aronoff, M. and R.T.Oehrle (eds.) Language, Sound, Structure, Cambridge: MIT Press, pp. 318-329.

Hayes, B. (1986a), "Inalterability in CV Phonology" Language 62.2, pp. 321-351.

Hayes, B. (1986b), "Assimilation as Spreading in Toba Batak", Linguistic Inquiry, 17.3, pp. 467-499.

Herbert, R.K. (1986), Language Universals, Markedness Theory and Natural Phonetic Processes, Berlin: Mouton de Gruyter.

Hoffmann, C. (1973), "The Vowel Harmony System of the Okpe Monosyllabic Verb", Research Notes, 6, University of Ibadan.

Hyman, L.M. (1975), Phonology: Theory and Analysis, New York: Holt, Rinehart and Winston.

- Hyman, L. (1970) "The Role of Borrowing in the Justification of Phonological Grammars" in Studies of African Linguistics, 1, pp. 1-48.
- Ito, J. (1984), "Melodic Dissimilation in Ainu" in Linguistic Inquiry, 15, pp. 505-513.
- Ito, J., and R.A. Mester (1984), "The Phonology of Voicing in Japanese" in Linguistic Inquiry, 17, pp.49-73.
- Jakobson, R. (1941), Kindersprache, Aphasie, und allgemeine Lautgesetze, Uppsala: Universitets Aarskrift.
- Jakobson, R. (1948), "Russian Conjugation" in Word, 4, also in Selected Writings, II, The Hague: Mouton, pp. 119-129.
- Jakobson, R. (1952), "Langues Paléosibériennes" in Meillet A. et M. Cohen (eds.), Les langues du monde, 1, Paris: CNRS, pp. 403-431.
- Jakobson, R. (1956), "Die verteilung der stimmhaften und stimmlosen gerauschaute im Russischen" in M. Woltner and H. Brauer (eds.) Festschriften für Max Vasmer, Berlin, Freie Universität, 199. Also Selected Writings, II, The Hague: Mouton, pp. 505-509
- Jakobson, R. (1978), "Mutual Assimilation of Russian Voiced and Voiceless Consonants" in Studia Linguistica, 32, pp.107-110
- Kean, M.I. (1975), The Theory of Markedness in Generative Grammar, Ph.D. Dissertation, MIT. Cambridge. Mass.
- Kenstowicz, M. (1979), "Vowel Harmony and Epenthesis in Chukchee" in Chicago Linguistic Society, 15.
- Kenstowicz, M. and C. Kisseberth (1977), Topics in Phonological Theory, New York Academic Press.
- Kiparsky, P. (1968) "Linguistic Universals and Linguistic Change" in E. Bach and R. Harms, eds., Universals in Linguistic Theory, New York: Holt, Rinehart and Winston, pp. 171-204.

- Kiparsky, P. (1973) "Phonological Representations" in O.Fujimura, ed., Three Dimensions of Linguistic Theory, New York: Holt, Rinehart and Wiston, pp.171-202
- Kiparsky, P. (1981) "Vowel Harmony", unpublished ms., MIT, Cambridge, Mass.
- Kiparsky, P. (1982), "Lexical Morphology and Phonology" in The Linguistic Society of Korea (ed.) Linguistics in the Morning Calm, Seoul: Hanshin Publishing Company.
- Kiparsky, P. (1984), "On the Lexical Phonology of Icelandic" in C.C.Elert, I.Johansson, E.Strangert, ed., Nordic Prosody III, University of Umeå, pp. 135-156.
- Kiparsky, P. (1985), "Some consequences of Lexical Phonology" in The Phonology Yearbook, 2, pp. 85-138.
- Kontra, M. and C. Ringen (1986), "Hungarian Vowel Harmony: the Evidence from Loanwords", in Ural-Altische Jahrbucher, 58, pp. 1-13.
- Krause, S.R. (1980), Topics in Chukchee Phonology and Morphology, PhD. Dissertation, University of Illinois.
- Krohn, K. (1972), "On the Sequencing of Tautosegmental Features", in Papers in Linguistics, 5, pp. 114-123
- Krupa, V. (1968), The Maori Language, Moskow.
- Kuipers, A. H. (1960), Phoneme and Morpheme in Kabardian, The Hague: Mouton.
- Lass, R. (1984), Phonology, Cambridge: Cambridge University Press.
- Levin, J. (1985), A Metrical Theory of Syllabicity, Doctoral Dissertation, MIT, Cambridge, Mass.
- Levin, J. (1988) "Constraints on Rime-Internal Syllabification in French.

Elimination, Truncation" in Birdsong, D, and J. Montreuil (eds.)
Advances in Romance Linguistics, Dordrecht: Foris.

- Lightner, T. (1972) Problems in the Theory of Phonology. I. Russian Phonology and Turkish Phonology, Edmonton Linguistic Research.
- Loi Corvetto, I. (1975), "La metaforesi nell'italiano regionale della Sardegna" in Lingua e Stile, X.1, pp. 57-79.
- Lovins, J. (1973), Loanwords and the Phonological Structure of Japanese, Doctoral Dissertation, University of Chicago.
- Lovins, J. (1974), "Why Loan Phonology is Natural Phonology" in Natural Phonology (parasession Volume of the Chicago Linguistic Society), Chicago: University of Chicago Department of Linguistics, pp.240-251.
- Maddieson, I. (1984), Patterns of Sounds, Cambridge: Cambridge University Press.
- Maddieson, i., (1985), "Borrowed Sounds" in UCLA Working Papers in Phonetics, 61, pp.55-64.
- Mascaro, J. (1976), The Catalan Phonology and the Phonological Cycle, Ph.D. Dissertation. MIT, Cambridge, Mass. (Distributed by Indiana University Linguistic Club).
- McCarthy, J.J. (1984), "Theoretical Consequences of Montañés Vowel Harmony" in Linguistic Inquiry, 15, pp. 291-319.
- McCarthy, J.J. (1986), "OCP effects: Gemination and Anti-Gemination", Linguistic Inquiry, 17, pp.207-293.
- Mohanan, K.P. (1982), Lexical Phonology, Indiana University Linguistic Club, Bloomington, Indiana.
- Mohanan K.P. and T. Mohanan (1984) "Lexical Phonology of the Consonantal System in Malayalam" in Linguistic Inquiry, 16, pp. 575-602.

- Mohanan, K.P. (1986) The Theory of Lexical Phonology. Dordrecht: Reidel.
- Paradis, C. (1987), "On Constraints and Repair Strategies", ms., MIT
- Poser, W. (1982), "Phonological Representations and Action-at-Distance" in H. Van Der Hulst and N. Smith (eds.), The Structure of Phonological Representations, Part.2, Dordrecht:Foris.
- Pulleyblank, D. (1985), "Underspecification and Low Vowel Harmony in Okpe, ms., University of Southern California, Los Angeles, California.
- Pulleyblank, D. (1987), "Vocalic Underspecification in Yoruba", ms., University of Southern California, Los Angeles, California.
- Reid, L.A. (1973), "Diachronic Typology of Philippine Vowel Systems" in T.Sebeok (ed.), Current Trends in Linguistics, The Hague: Mouton, pp.485-506.
- Renzi, L. (1985), Nuova Introduzione alla Filologia Romanza, Bologna: Il Mulino.
- Ribezzo, F. (1912) Il dialetto apulo-salentino di Francavilla Fontana, Martina Franca.
- Rigsbi, J. (1965), "Continuity and Change in Sahaptian Vowel Systems" in International Journal of American Linguistics, 31, pp. 306-311.
- Ringen, C. (1980), "A Concrete Analysis of Hungarian Vowel Harmony" in R. Vago (ed.), Issues in Vowel Harmony, Amsterda: John Benjamins B.V., pp.135-154.
- Ringen, C. (1978), "Another View of the Theoretical Implications of Hungarian Vowel Harmony" in Linguistics Inquiry, 9, pp. 105-115.
- Rohlf's, G. (1966) Grammatica storica della lingua italiana e dei suoi dialetti: Fonetica, Torino: Einaudi.

- Sagey, E. (1986), The Representation of Features and Relations in Non-Linear Phonology, Doctoral Dissertation, MIT, Cambridge, Mass.
- Schachter, P. and V. Fromkin (1968), A Phonology of Akan: Akuapem, Asante and Fante, Working Papers in Phonetics, 9, University of California, Los Angeles.
- Schane, S. (1968), French Phonology and Morphology, Cambridge, Mass.: MIT Press.
- Schein, B and D. Steriade (1986), "On Geminate", Linguistic Inquiry 17.4, pp. 691-744.
- Schlingwein, D., (1987), "P-bearing Units: a Study of Kinande Vowel Harmony" in Proceedings of NELS 17.
- Singh, R. (1987), "Well-Formedness Conditions and Phonological Theory" in W. Dressler (ed.), Phonologica, 84, Cambridge: Cambridge University Press.
- Skorik, P. (1961), Grammatika Cukotskogo Jazyka, Moskow.
- Stampe, D. (1972), How I spent my summer vacation, Ph.D. Dissertation, University of Chicago.
- Stanley, R (1967), "Redundancy Rules in Phonology" in Language, 43, pp. 393-436.
- Stehl, T. (1980), Die Mundarten Apuliens. Historische und Strukturelle Beitrage. Munster: Aschendorff.
- Steriade, D. (1982), Greek Prosodies and the Nature of Syllabification, Doctoral Dissertation, MIT, Cambridge, Mass..
- Steriade, D. (1987), "Locality Conditions and the Feature Geometry", ms., MIT, Cambridge, Mass..
- Steriade, D. (1987) "Redundant Values" in CLS 23. Parasession on Autosegmental and Metrical Phonology, pp. 339-363.

- Stevens, K. , S.J. Keyser and H. Kawasaki (1987) in J.Perkell and D. H. Klatt, Symposium on Invariance and Variability, Lawrence Erlbaum Assoc.
- Stewart, J.M. (1972), "Niger-Congo, Kwa" in T. Sebeok, ed., Linguistics in Sub-Saharan Africa, Current Trends in Linguistics, vol.7, The Hague: Mouton,pp.179-213.
- Thomas, J. (1963), Le Parler Ngbaka de Bokanga, The Hague: Mouton.
- Trubetzkoy, N.S. (1969), Principles of Phonology, Berkeley: University of California Press. (English Translation of Grundzuge der Phonologie, Travaux du Cercle Linguistique de Prague, 7, 1939).
- Vago, R. (1976), "Theoretical Implications of Hungarian Vowel Harmony", Linguistic Inquiry, pp. 243-263.
- Valente, V. (1975), Puglia, Pisa: Pacini.
- Weinrich, H (1958), Phonologischen Studien zur romanischen Sprachgeschichte, Munster: Aschendorff.
- Williams, E. (1976) "Underlying Tone in Margi and Igbo" Linguistic Inquiry, 7, pp.463-484.
- Yip, M. (1988), "The Obligatory Contour Principle and Phonological Rules: A Loss of Identity" in Linguistic Inquiry.