

MIT Open Access Articles

FabRobotics: Fusing 3D Printing with Mobile Robots to Advance Fabrication, Robotics, and Interaction

The MIT Faculty has made this article openly available. **Please share** how this access benefits you. Your story matters.

Citation: Bhattacharya, Ramarko, Lindstrom, Jonathan, Taka, Ahmad, Nisser, Martin, Mueller, Stefanie et al. 2024. "FabRobotics: Fusing 3D Printing with Mobile Robots to Advance Fabrication, Robotics, and Interaction."

As Published: <https://doi.org/10.1145/3623509.3633365>

Publisher: ACM|Eighteenth International Conference on Tangible, Embedded, and Embodied Interaction

Persistent URL: <https://hdl.handle.net/1721.1/153626>

Version: Final published version: final published article, as it appeared in a journal, conference proceedings, or other formally published context

Terms of Use: Article is made available in accordance with the publisher's policy and may be subject to US copyright law. Please refer to the publisher's site for terms of use.



FabRobotics: Fusing 3D Printing with Mobile Robots to Advance Fabrication, Robotics, and Interaction

Ramarko Bhattacharya*
University of Chicago
Chicago, IL, USA
ramarkob@uchicago.edu

Jonathan Lindstrom*
University of Chicago
Chicago, IL, USA
Carnegie Mellon University
Pittsburgh, PA, USA
jmlindst@andrew.cmu.edu

Ahmad Taka*
MIT CSAIL
Cambridge, MA, USA
ahmadtak@mit.edu

Martin Nisser
MIT CSAIL
Cambridge, MA, USA
nisser@mit.edu

Stefanie Mueller
MIT CSAIL
Cambridge, MA, USA
stefanie.mueller@mit.edu

Ken Nakagaki
University of Chicago
Chicago, IL, USA
knakagaki@uchicago.edu

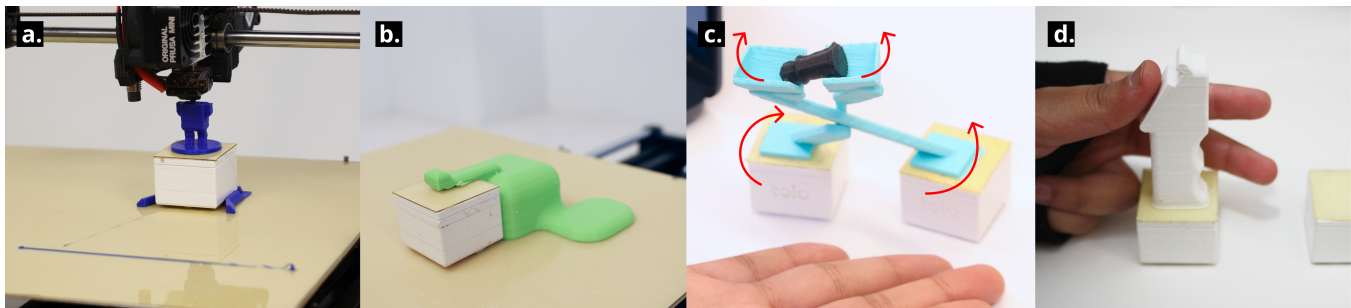

Figure 1: FabRobotics is a fabrication pipeline that fuses 3D printers with mobile robots (a). It can be used to assist fabrication, using robots to mediate in 3D printing tasks to save printing time (b); it can make robots adaptive by printing new features onto them to improve their capacity to carry out manipulation [e.g. with a scissor gripper controlled by two robots](c) or locomotion tasks; and it allows for making an interface to highly adaptive and configures the shape and I/O on-demand (d).

ABSTRACT

We present FabRobotics, a digital fabrication pipeline that combines traditional 3D printing with mobile robots. By integrating these two technologies, we aim to create new opportunities for 3D printers to fabricate objects quickly and efficiently, and for mobile robots to enhance their adaptability and interactivity. To explore this novel research opportunity, we have developed a proof-of-concept implementation pipeline, allowing users to execute hybrid turn-taking control of a 3D printer and mobile robots to autonomously 3D print objects on/with mobile robots. The system was implemented with commercially available 3D printers (Prusa MINI) and mobile robots (toio), and we share various techniques and knowledge specific to fusing 3D printers and mobile robots (e.g. printing mobile robot

docks for stable prints on robots). Based on the proof-of-concept system, we demonstrate various application usages and functionalities, showcasing how 3D printing and mobile robots can mutually advance each other for novel fabrication and interaction. Lastly, we share our further exploration of extended prototypes (e.g. fusing two printers) and discuss future technical challenges and research opportunities.

CCS CONCEPTS

• **Human-centered computing** → **Human-computer interaction**.

KEYWORDS

Digital fabrication; Swarm user interfaces; Robotics

ACM Reference Format:

Ramarko Bhattacharya, Jonathan Lindstrom, Ahmad Taka, Martin Nisser, Stefanie Mueller, and Ken Nakagaki. 2024. FabRobotics: Fusing 3D Printing with Mobile Robots to Advance Fabrication, Robotics, and Interaction. In *Eighteenth International Conference on Tangible, Embedded, and Embodied Interaction (TEI '24)*, February 11–14, 2024, Cork, Ireland. ACM, New York, NY, USA, 13 pages. <https://doi.org/10.1145/3623509.3633365>

*The first three authors contributed equally to this research.

Permission to make digital or hard copies of all or part of this work for personal or classroom use is granted without fee provided that copies are not made or distributed for profit or commercial advantage and that copies bear this notice and the full citation on the first page. Copyrights for components of this work owned by others than the author(s) must be honored. Abstracting with credit is permitted. To copy otherwise, or republish, to post on servers or to redistribute to lists, requires prior specific permission and/or a fee. Request permissions from permissions@acm.org.

TEI '24, February 11–14, 2024, Cork, Ireland

© 2024 Copyright held by the owner/author(s). Publication rights licensed to ACM.

ACM ISBN 979-8-4007-0402-4/24/02...\$15.00

<https://doi.org/10.1145/3623509.3633365>

1 INTRODUCTION

3D printers today are the dominant digital fabrication machine used by lay users for rapid prototyping [26]. They can produce complex geometries at increasingly high resolutions with an expanding repertoire of materials. Among them, FDM (Fused Deposition Modeling) 3D printers are the most widely used type of 3D printer for consumers, which extrude melted plastic filaments to print models. They are readily available at a range of form factors and prices even below \$200 [3]. Accordingly, research in advancing and augmenting FDM 3D printers has been a popular stream of research in the past decade in the Human-Computer Interaction (HCI) field, to resolve diverse problems in waste of support materials [40], multi-colored prints [33], and automated assembly [12], which exhibit active and diverse research opportunities.

On the other hand, mobile robots today are proliferating increasingly into the lives of everyday users and have already been deployed commercially for tasks including cleaning [28] and inspection [43], with their growing technical capabilities expected to have profound societal impacts in the years to come [27]. In the HCI domain, researchers have notably made use of robots in the form of Swarm User Interfaces (SUIs) for tasks including interaction and manipulation (Zoooids [13], Shapebots [31]). Furthermore, the mobile robots used in SUIs are typically characterized by planar, wheeled locomotion capabilities and a sensor/actuation suite in an inexpensive, compact form factor that has become increasingly accessible in recent years. However, while these robots enjoy both interactivity and mobility, the robots, once assembled, are typically *homogeneous, low resolution, and static*—that is, each robot typically inhabits an identical form factor, the swarm does not permit rendering displays with high resolution (because the pixel resolution is equivalent to the size of each robot), and the robots cannot flexibly update their geometries to adapt to changing user needs. While a method to reconfigure swarm robots' shape and interactivity using mechanical attachment was introduced in HERMITS [19], they are limited to pre-prepared attachments, which cannot provide highly adaptable in-situ shapes and functionalities.

In this paper, we explore the opportunities provided by fusing the capabilities of 3D printers and mobile robots into a single architecture to leverage and complement the native advantages of each: using mobile robots to intervene dynamically with 3D printing, as well as using the 3D printer to flexibly update homogeneous, mesoscale robots with high-resolution features to improve their capacity for manipulation and interaction. To this end, we introduce FabRobotics, a pipeline that fuses digital fabrication with mobile robotics by grafting the control of mobile robots into the 3D printing process. We demonstrate how this merger enables *Assistive Fabrication*, assisting today's 3D printing workflow by allowing part assembly and savings in time, and cost for individual 3D-printed parts. We also demonstrate how FabRobotics allows for *Adaptive Robotics* by printing new features onto robots to improve their capacity to handle objects and locomotion. Finally, we show that our system can be used as an *On-demand Interface*, leveraging our hybrid control architecture to support novel input-output modalities for users to direct the FabRobotics 3D printer's fabrication and the robot's locomotion capabilities for tangible interactions. As an interface, the system advances research in Tangible UIs to

gain in-situ shapes and functionality, thanks to the combination of 3D printers (which fabricate high-resolution geometric shapes on-demand) and mobile robots (which dynamically make printed shapes and mechanisms actuated and interactive). Motivated by the immense research opportunities of fusing the two hardware modalities, our paper intends to broadly contribute to the HCI domain across TUIs, fabrication, and robotics by exploring this novel emerging space through a proof-of-concept prototype system.

Below, we introduce the related literature to this work and give an overview of our digital fabrication pipeline mediated by robotics. We illustrate how FabRobotics' *assistive, adaptive, and interactive* architecture enriches 3D printing with applications uniquely afforded by the union of fabrication and robots that include environment interaction, object manipulation, part assembly, and visualization. We then discuss the implementation of our proof-of-concept system, developed using commercially available hardware, that manages control of 3D printers and toio robots uniformly via a turn-taking control pipeline as well as a GUI control tool to allow users to configure the print process. We demonstrate multiple mock-up user scenarios for the proof-of-concept interactive system across gaming/storytelling, and calendar-syncing 3D-printed dynamic UIs. Finally, because this paper explores the first step towards a broad suite of research opportunities in fusing 3D printers and mobile robots, we discuss its limitations and potential avenues for future work to share and chart the open research space with the HCI community.

This paper's key contributions include:

- A novel system and approach to fusing 3D printers and mobile robotics to assist fabrication, reconfigure robotic functionality, and create on-demand interactivity.
- A generalizable software architecture, including a GUI tool and a timeline manager, to automatically generate and execute timeline 'events' to the 3D printer and robots.
- Proof-of-concept implementation of FabRobotics with an inexpensive 3D printer (Prusa MINI) and commercially available mobile robots (toio).
- A demonstration of applications enabled by our system, including temporary support material, part assembly, visualization, and new user interactions.

2 RELATED WORK

2.1 Augmentations to 3D Printers

To expedite printing times, facilitate more complex geometries, and reduce support material, researchers have augmented 3D printers with various features, including custom accessories to their printheads.

Researchers have explored augmenting 3D printers' traditionally static buildplate with an actuated platform capable of rotation, to both minimize the printing time and to allow printing objects at angles (Revomaker [8], Patching Physical Objects [34]). Xu et al. [40] used an actuated print bed comprised of a grid of linearly actuated pins to serve as temporary support material for 3D printed parts. Similarly, Scrappy [36] reduces the overall time needed for a print by prompting users to insert scrap material to substitute for infill. ReForm [37] combined additive and subtractive manufacturing techniques by modifying a clay 3D printer with a mill

and structured light scanner, while Patching Physical Objects [34] and Scotty [16] similarly integrated a mill into existing 3D printing platforms to let users update statically printed parts. Takahashi et al. [33] introduced a method to perform multi-material printing with a single printer by preparing a filament distributed with multiple materials. In novel work, Katakura et al. [12] used a 3D printing head as a robotic manipulator, using it for applications that include breaking support material and actuating 3D-printed objects in situ.

In line with these works, we develop a novel approach to fusing mobile robots into the workflow of using a 3D printer to augment its capabilities. Our approach obviates the need for major changes to the 3D printer's mechanism itself, as the robots can independently locomote on the print bed. This utility is a key advantage of our system over alternative approaches, further supported by our methods of employment of commercially available toio robots.

2.2 Robots in digital fabrication

Researchers have also explored advancing the capabilities of 3D printing as well as other digital fabrication platforms by leveraging external robotic manipulators.

FormFab [18] used a robotically controlled heat gun in tandem with a vacuum forming platform to explore creating different geometries interactively. RoMa [23] transferred printing authority entirely to a robot arm, allowing the system to print large objects unconstrained by a typical build platform and supporting users to craft objects in real-time using an augmented reality (AR) headset. Leveraging multiple robots simultaneously, Poudel et al. [24] outlined an architecture for coordinating several robots to 3D print an object that relies on chunking [25] (partitioning) and scheduling its parts to parallelize the printing procedure. However, this requires dedicated mobile fabrication platforms, and does not support the assembly of disjoint parts.

Researchers, including Hongyao et al. [29], further accelerated printing times by parallelizing fabrication using four robotic arms. However, because each arm is stationary rather than mobile, the build volume remains unchanged. Jin et al [10] developed tool-path trajectories to allow multiple printhead nozzles to print onto the same plane concurrently. Despite this, fabricated objects experience the same limitation on build volume. Big Area Additive Manufacturing (BAAM) aims to scale 3D printed objects to large scales. In order to accomplish this in reasonable time frames, the nozzle size is scaled commensurately, leading to poorer resolution and geometric deviations of structures at this scale [7].

The robotics community has engaged equally deeply in the task of robotic fabrication. In work most aligned with our own, inspired by termites, Werfel et al. [38] used a collective of homogeneous climbing robots to construct 3D geometries from modular blocks using just local sensing and simple rules. However, the resolution of the structure is bound to the size of the individual modules, without permitting higher resolution features or adapting the robots themselves to new tasks. Others have sought to address the challenge of custom-fabricating robots directly. In work that leveraged a custom hardware add-on fitted onto a laser cutter, LaserFactory [21] fabricated a fully functioning, user-designed quadrotor in a single machine. In another work, Wakimoto et al. [35] proposed 3D

printing directly onto the bodies of pet robots to individualize their appearances.

Building on these developments, our approach introduces a generalizable architecture to let 3D printers augment mobile robots, and for robots to assist in fabrication, opening new opportunities for user interaction in parallel. Because the cost of an individual mobile robot is less than a typical robotic arm, this architecture supports using a larger number of robots for a richer interaction space. And by substituting mobile robots for stationary robotic arms, objects can be assembled outside of the printer, to build assemblies covering an area beyond the size of either the build plate or the reach of an individual robot arm.

2.3 Swarm User Interfaces

In the growing class of interfaces known as Swarm User Interfaces [13] (SwarmUIs), researchers have used wheeled mobile robots for applications ranging from visualization and assembly to physical notifications.

Zooids [13] used a swarm of wheeled mobile robots localized using a structured light projector to allow users to interact with the robot collective to draw lines, acquire shapes, and represent data points on a projected chart. Le Goc et al. [14] similarly used a fleet of self-propelled, cm-scale wheeled robots for visualization and data representation. Shapebots [31] built on this work with a swarm user interface whose individual wheeled robots include a linear actuator orthogonal to the locomotion plane, using this to further expand the breadth of physical affordances and data representation capabilities of SwarmUIs. (Dis)appearables [20] leveraged a mobile robot platform together with an infrastructure of lifts, trap doors, and ramps to build set stages that were used to create a tangible user interface that appeared and disappeared from a user's attention. In closely related work, HERMITS [19] used a fleet of homogeneous mobile robots in conjunction with 3D-printed shells, named 'mechanical shells,' that converted the robots' planar locomotion into devices capable of both linear and rotary actuation. This showed how to interface homogeneous mobile robots with 3D-printed transmissions to extend the ability of the robots to manipulate their environments, but this heterogeneity was achieved using physically separate shells, built ad hoc, without integration into the 3D printing pipeline. The idea of 'mechanical shell' attachments was further expanded with AeroRigUI [42] and ThrowIO [15] to enable spatial interaction with SUIs.

In work particularly foundational to our own, Zhao et al. [44] performed real-time assembly of low-resolution structures using mobile robots and 3D-printed passive components, exploring opportunities in tangible interaction and virtual reality. However, while this afforded rapid assembly, the geometries created are discretized to a granularity equal to the size of each robot, and may therefore be primarily suited for low-resolution haptic proxies in virtual reality.

In summary, SwarmUIs to date have typically relied on homogeneous robots; here, we facilitate the online creation of heterogeneous SwarmUIs to explore a wider assortment of applications using fewer robots. In addition, swarm homogeneity coupled with limited swarm sizes has meant that the display resolution of the shapes acquired has to date been low, as it has been directly coupled to the robots' size. In this work, we print high-resolution structures

onto mesoscale robots to show that display resolution need not be dictated by robot size, moving the interaction modality from things toward stuff [13]. Finally, we have conducted early explorations into supporting and integrating SwarmUIs with 3D printing [11, 20] through automation and user interaction. While these experiments remain preliminary, our work is intended to comprehensively review and explore the opportunities available in fusing 3D printers and mobile robots, while taking a step towards a first technical pipeline to address it.

3 FABROBOTICS OVERVIEW, DESIGN SPACE, AND EXAMPLES

In this section, we give an overview of the FabRobotics setup and classify the application opportunities opened by the unique fusion of 3D printing and mobile robots, namely for *assistive fabrication*, *adaptive robotics*, and *on-demand interaction*.

Figure 2 depicts the design space. In the figure, the design space elements highlighted with yellow are not compatible with our introduced automated system, as in Figure 4, while this was preliminarily explored with our extended prototype that contains two 3D printers and manually controlled robots, which is further elaborated in 6.1. Rather than getting constrained by the proposed implementation, this design space intends to overview available opportunities.

3.1 Overall Configuration

At its heart, FabRobotics is a control architecture that mediates between 3D printers and mobile robots (Figure 2 left). In this work, we use a 3D printer and multiple tabletop mobile robots (our demonstration includes 1-5 robots) to showcase the opportunities that arise from using a 3D printer and robots concurrently. A slope is affixed to each 3D printer bed to allow robots to travel in and out of the print beds dynamically. The system could be extended to more than one printer to enable extended functionalities (highlighted in yellow in Figure 2).

Figure 3 represents the hardware setup of our FabRobotics prototype, based on Prusa MINI 3D printer [5] and multiple toio mobile robots [6].

3.2 Assistive Fabrication

FabRobotics can be used to assist and augment the nominal 3D printing process to expedite printing times, and to coordinate between multiple 3D printers to contribute to the same printed object.

Dynamic support The mobile robots can locomote on the print bed to serve as *temporary support structures* for 3D printed parts with overhangs. While 3D printers typically print support structures to this end, this requires more time. Figure 1 b demonstrates a simple example of this with an elephant-shaped object with an overhanging component (the elephant trunk), where a robot acts as a dynamic support. Further, Figure 4 a demonstrates a more advanced example where multiple robots placed side-by-side replace printed supports. Stackable or height-changing robots [31] could be further employed on this end.

Serial Multi-Print Thanks to the mobility of the robots on the print bed, the robots can assist in the 3D printing process by automatically printing different objects one after another, in serial.

This can be more efficient than printing multiple objects in parallel if users want to collect individual prints as they are finished (Figure 4 a-2).

Assembly Mobile robots can *assemble* objects that need to be combined from disjoint parts. By allowing mobile robots to bring parts from the build plate and assemble them outside the 3D printer, our approach enables the assembling of simple objects. By coordinating between multiple toios and printers, it becomes possible to *parallelize printing* by partitioning a single object across multiple printers to be fabricated simultaneously, after which mobile robots can assemble them (Figure 4 a-3). This also has the potential to automatically print and assemble shapes that is *larger than the print bed*.

Multi-Material Printing While single-nozzle and single-material printers are commonplace, FabRobotics can coordinate one or more robots to automatically move between printers, allowing each printer to deposit material directly onto the mobile robots. This enables printing objects comprised of *multiple materials and colors* from disjoint, single-extruder printers without requiring the use of a multi-head printer, for example, the zebra shown in Figure 4 a-4.

As highlighted in Figure 2, *Assembly and Multi-Material Printing require two 3D printers; hence, they are explored as extended functionalities (not developed with our single printer proof-of-concept), and detailed in the future work section.*

3.3 Adaptive robotics

FabRobotics also allows the use of 3D printers to support and augment the mobile robots' capabilities, including their ability to manipulate objects and locomote across a terrain – two of the most fundamental physical functionalities in robotics. This may in turn improve the robots' abilities to assist in fabrication and interaction tasks.

Object handling The 3D printer can fabricate extensions in the form of *manipulators* or mechanisms directly onto the surface of the mobile robots in order to adapt them to the needs or objects the robot is to interface with. For example, a custom gripper (Figure 1 a) can be printed onto a pair of robots to accurately manipulate objects. The example in Figure 1 works by making two mobile robots control the scissor gripper to handle and release a small object. Such an adaptive manipulator might be used for assisting 3D print assembly as well.

Locomotion The printer can fabricate structures that support the robots' ability to traverse heterogeneous terrain. By printing a slope or a bridge, for example, robots can be empowered to locomote across uneven or disjoint surfaces or to reach higher elevations (Figure 4 b). While building attachments for mobile/swarm robots has been explored in the past [19, 20, 44], using FabRobotics, 3D printers can print new features that let mobile robots adapt to new environments and needs dynamically and flexibly.

3.4 On-demand User Interaction

FabRobotics can also support on-demand interactions with the user in a variety of modalities.

Inputs & Affordances FabRobotics allows for printing highly customizable input UI elements on-demand, such as a user-customized joystick grip onto a mobile robot, fitting an individual user's hand.

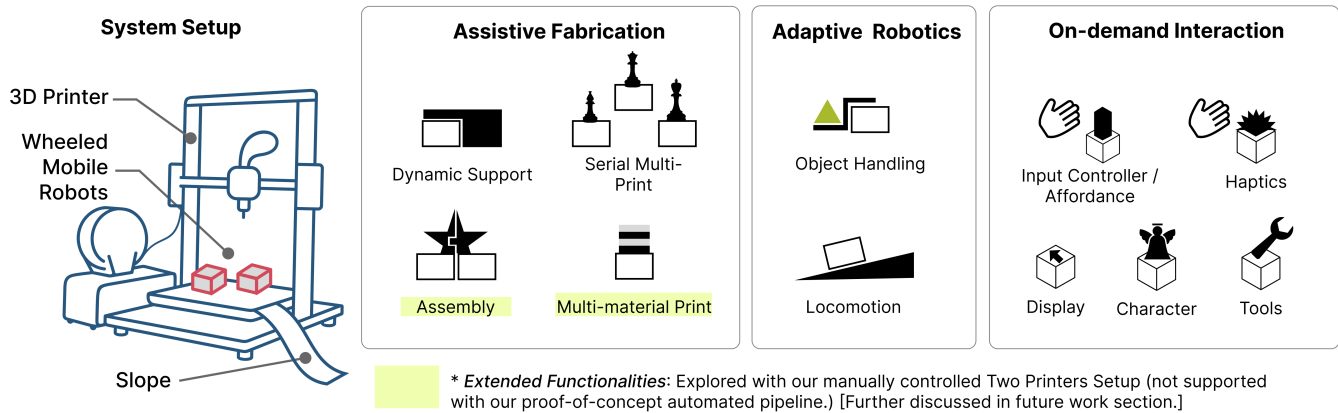

Figure 2: The overall configuration of FabRobotics consists of a 3D printer and wheeled mobile robots. By fusing the two, we explore a design space that covers new opportunities for robots to assist fabrication, 3D printers to adapt robots to tasks, and on-demand interaction applications for users to interact directly with robots and printers.

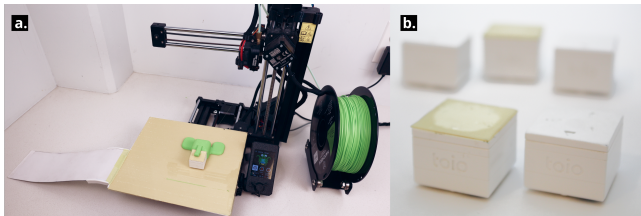

Figure 3: At its heart, FabRobotics is a control architecture that mediates between (a) 3D printer, Prusa MINI [5], and (b) mobile robots, toio [6].

This can further provide an actuated input controller to drive other robots (Figure 1 d). Similarly, printing a knob-like grip affords rotational input to control mobile robots. The robots can then be made to dynamically follow the user’s commands or other mobile robots for different applications.

Haptics New haptic textures can also be rapidly printed onto mobile robots to convey affordances or digital information (Figure 4 c-1). While SwarmUIs are traditionally homogeneous, FabRobotics lets the user print custom textures onto mobile robots or make different robots into diverse haptic props, which may be particularly useful for visually impaired users. While prior research has investigated replicating diverse haptic textures using 3D printers [32], FabRobotics allows for automatically covering the robots with diverse textures for haptic interactions.

Displays Users can also print high-resolution features onto mobile robots to support their use as tangible displays. While SwarmUIs have previously illustrated how their robot collectives can display particular shapes, the pixel resolution of these displays has been defined by the robot size, yielding granular visual representations. Using FabRobotics, the printer can augment the appearance of the robots with high-resolution features set by the print resolution, which can be used to create new visual and haptic interactions rapidly (Figure 4 c-2).

Character Similarly, expressive shapes, or characters, can be dynamically printed onto the robots, providing users with a certain narrative. Though HERMITS [19] has explored such an application with pre-printed mechanical shells, FabRobotics allows for such an application with high customizability and flexibility by printing shapes on-demand, which could open new possibilities for gaming, story-telling, or human-robot interaction.

Tools Finally, FabRobotics can print custom tools for users to work on specific tasks. Once the system tracks the users’ needs, the system itself could print and bring the tool to the users that fit particularly to their tasks. With the actuated components, users could even get assisted by the robots’ actuation for the usage of tools (Figure 4 c-3).

Overall, these functionalities arise from the tightly coupled coordination between 3D printers and mobile robots to advance the disparate and combined capabilities of 3D printing, robots, and tangible user interfaces. Furthermore, these functionalities could be combined for extended applications (e.g. for adaptive robots to help assistive fabrication by removing support and assembly [12] or for interactive fabrication [39]), which are potential opportunities beyond our work. The section below introduces the implementation of the proof-of-concept prototypes that demonstrate this design space.

4 IMPLEMENTATION

In order to control a 3D printer and toio robots simultaneously, we designed a software architecture that can mediate control between the two while providing a GUI for users to plan and monitor their print. As depicted in Figure 5, alongside the toio robots and a Prusa MINI 3D printer, our setup was operated using two Raspberry Pi 4 model B single-board computers: **1. A Primary Raspberry Pi** which is hosting a Flask server [2] that contains the GUI and the core control management system, as well as **2. A Secondary Raspberry Pi**, which is hosting an OctoPrint server: an open-source project to allow wireless control of 3D printers [4]. The secondary

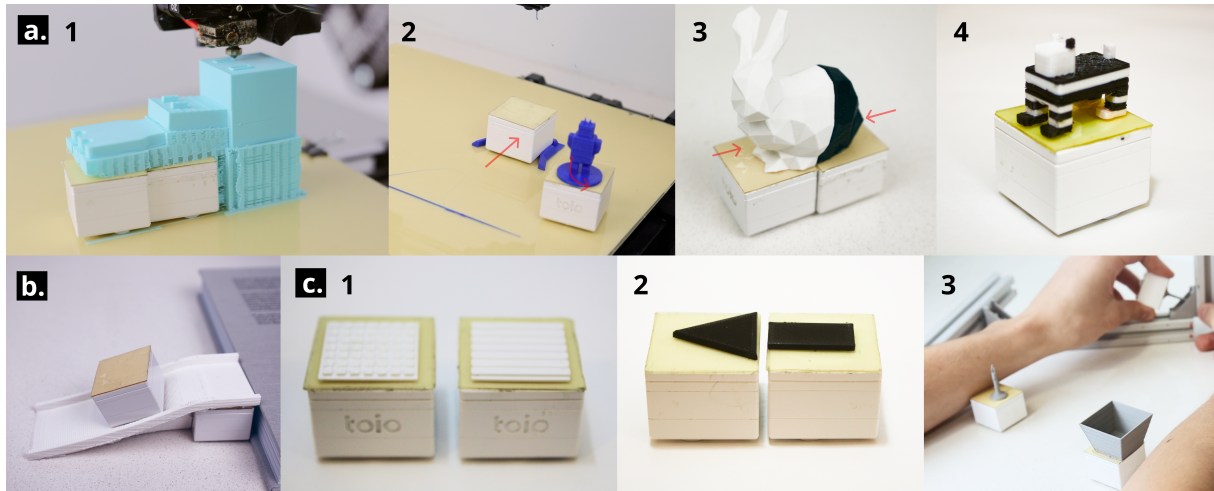

Figure 4: FabRobotics's design space, a) Assistive Fabrication, b) Adaptive Robotics, and c) On-demand Interaction

Raspberry Pi would directly communicate with a Prusa MINI 3D printer via a serial mini-USB port. The primary Pi communicates to the secondary Pi through OctoPrint's API client, allowing for near-total control of the printer from the primary Raspberry Pi through wireless API requests.

In the section below, we first describe *the hardware (3D printer and robots)*, *the user and system workflow*, and an overview of the software architecture that allows for turn-taking control between robots and a 3D printer in FabRobotics. The code is open-sourced in GitHub page¹.

4.1 Hardware

Toio Mobile Robot Platform Due to their small size (31.8mm x 31.8mm x 24mm), cost (\$34 unit price), and open source API, we chose Sony's toios [6] as our mobile robot platform. These robots include an accessible BLE (Bluetooth Low Energy) interface, enabling communication from various computers and microcontroller boards. These robots are also capable of localization within a precision of 1mm on the accompanying toio mat, discussed below. This mat can be cut and bonded to surfaces for the toio to localize on, including a 3D printer's build platform and the ramp we build to lead onto it. The toios' motors can achieve a rotation speed of 494 RPM each, which can be actuated individually or in unison, corresponding to a maximum travel speed of 196mm/s to enable responsive applications.

To 3D print directly on toio robots' top surfaces, we have added 0.13mm PEI sheets, a common material used for 3D printer beds. We also bonded two circular Neodymium magnets (6mm x 1mm), supported by a 3D printed holder, to the bottom of each robot to provide greater stability as they traverse the magnetic ramps.

Prusa MINI 3D Printer We chose the Prusa MINI as our 3D printer. In addition to its low cost for a printer (\$400), the firmware and slicing software of the Prusa MINI are open source and well

documented. This streamlines designing FabRobotics' control architecture to integrate robot locomotion into the 3D printing process, as well as future expansions to the work.

As for modifying the 3D printer, we adhered toio mats to the print bed to enable toios to localize themselves on the print bed. We bonded a 0.13mm PEI sheet onto the print bed mats for more reliable print adhesion to their surfaces and to help prevent thermal damage to the toio mat during printing. To facilitate the locomotion of the toio robots outside of the print bed, we fabricated a magnetic ramp using 430 stainless steel. We adjoin the ramp to the print bed using a 3D printed attachment with embedded magnets and smooth the connection between the ramp and bed with tape.

For print material, we used PLA (relatively easier to stick on non-heated surfaces among common 3D print filament materials), with a 215 °C nozzle temperature and a 60 °C bed temperature. We exclusively used PrusaSlicer for all of our prints. For the slicing setting, we mostly use the Prusa Mini's *0.25 SPEED* preset, modified for a 0.30mm layer height and 5% infill, to minimize the print time. However, through our prototypes, we confirmed the system works with other print settings (under 0.25mm layer height, etc.), and hence, our technical approach should be generalizable.

4.2 System and User Workflow based on Two System Phases

Our core management system has two distinct phases: A *Planning Phase*, when a user interacts with the GUI to plan their print, and an *Execution Phase*, when the workflow of their print is executed. The user workflow of the *Planning Phase* consists of the following steps:

STEP 0: PREPARE A user prepares a G-code file based on an existing slicer software.

STEP 1: UPLOAD A user uploads their desired G-code file to the FabRobotics GUI.

STEP 2: CONFIGURE Based on the Planning UI (Figure 6), the user manually configures how the toio(s) will be placed and interact

¹URL: <https://github.com/AxLab-UofC/FabRobotics>

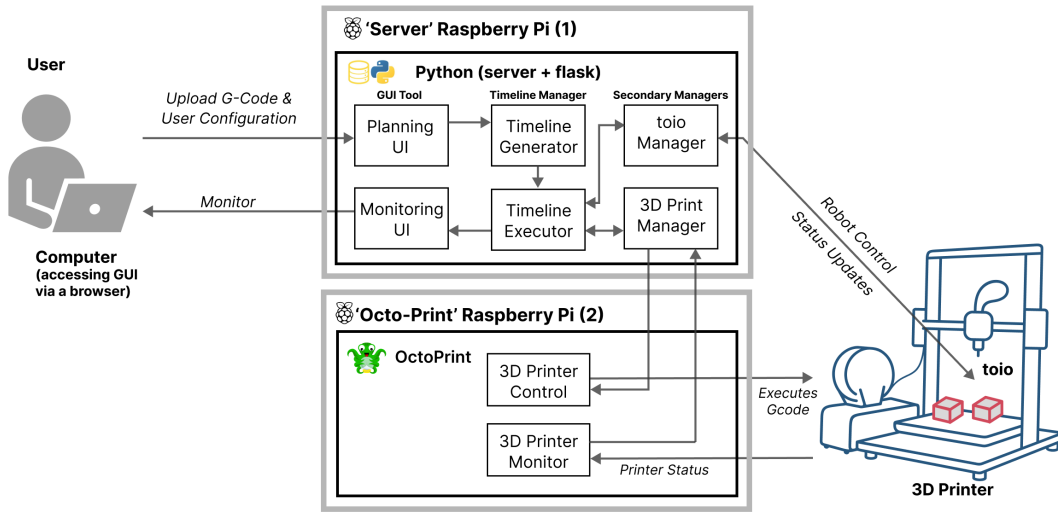

Figure 5: Software Pipeline of FabRobotics. G-code exported by the chosen slicer is modified to coordinate with toio mobile robots to intervene in the printing process.

with the G-code. In this step, they can make sure the system has a connection to toio(s).

STEP 3: REVIEW and CONFIRM The user reviews the timeline viewer and can execute the print by hitting “Start Print”

During the *Planning Phase*, the timeline generator will take the workflow designed by the user and convert them into a series of ‘print events’ and ‘toio events.’ After the user has confirmed the print, the *Execution Phase* will begin. At this time, the timeline executor will begin turn-taking control by iterating through the events synchronously (waiting for the completion of the previous command before the execution of the next command), until the print is completed. During ‘toio events,’ toios will be sent a series of commands to control their movements. During ‘print events,’ the printer will be sent G-code commands to control printing. At any given time, only the 3D printer manager or toio manager will be allowed to take control of the system. During the *Execution Phase*, users can monitor the progress and state of the system (e.g., printer’s temperature, toio’s battery) via the GUI.

4.3 Server and GUI

Back End: Our back end and software architecture comprises three “managers.” Firstly, there are the toio and print managers. The toio manager connects to and controls all the robots and localizes them on the print bed. The print manager is responsible for getting print updates, sending files to the printer through the OctoPrint API client, selecting files to print, and modifying G-code based on GUI inputs. This can include raising the Z values of the code, moving a dock to where the toio is placed, and cutting out the section of supports where a toio is placed. Therefore, the system can adapt to different types of support in lateral and vertical directions, as shown in Figure 4 a-1. Finally, there is the timeline manager, one of the core technical contributions in FabRobotics, enabling turn-taking control between the toio robots and the 3D printer. This manager is responsible for communicating between the toio and

print managers for successful collaboration. More details on all of these “managers” can be found in the ReadMe on the open-source GitHub page¹. **Front End:** Our front-end is hosted on a Flask Server, which presents a UI that regularly receives updates from the 3D printer manager and toio manager about the status of the 3D printer, toios, and the print progress. During the Planning Phase, user input is sent to the timeline manager, where it is processed, and new events are generated and added to the timeline on the GUI. During the Execution Phase, the timeline on the GUI presents the live completion and progress of events.

4.4 System Protocols

Here, we outline the protocols and print settings we developed to facilitate printing directly onto toio robots. These custom features are integrated into the timeline manager and will be automatically applied to any print as necessary.

Robot Dock for Stabilizing Print: To account for toio robots being destabilized during a print, the timeline generator will automatically add a print event for a toio dock to the timeline (Figure 7). The location of the robot dock will be automatically calculated based on the placement of toios by the user during the *Planning Phase*. While the toio is being printed on, it will drive forward into the dock at a constant speed to further stabilize the toio (see Figure 7). The robot dock is not needed when the toio acts as a support because it can stabilize itself by driving into the existing section of the print instead (see Figure 1). The robot dock takes approximately 7 minutes to print.

Collision Prevention between Robots and Extruder: While an event is active, the timeline manager prevents collision between the robots and the extruder. During a print where the toio is not being used (such as for a dock), all toios will be moved to the edges of the bed to prevent collision with the extruder. When toios are moving into a dock, the extruder will be moved upwards before resuming printing to prevent potential collision with the toios.

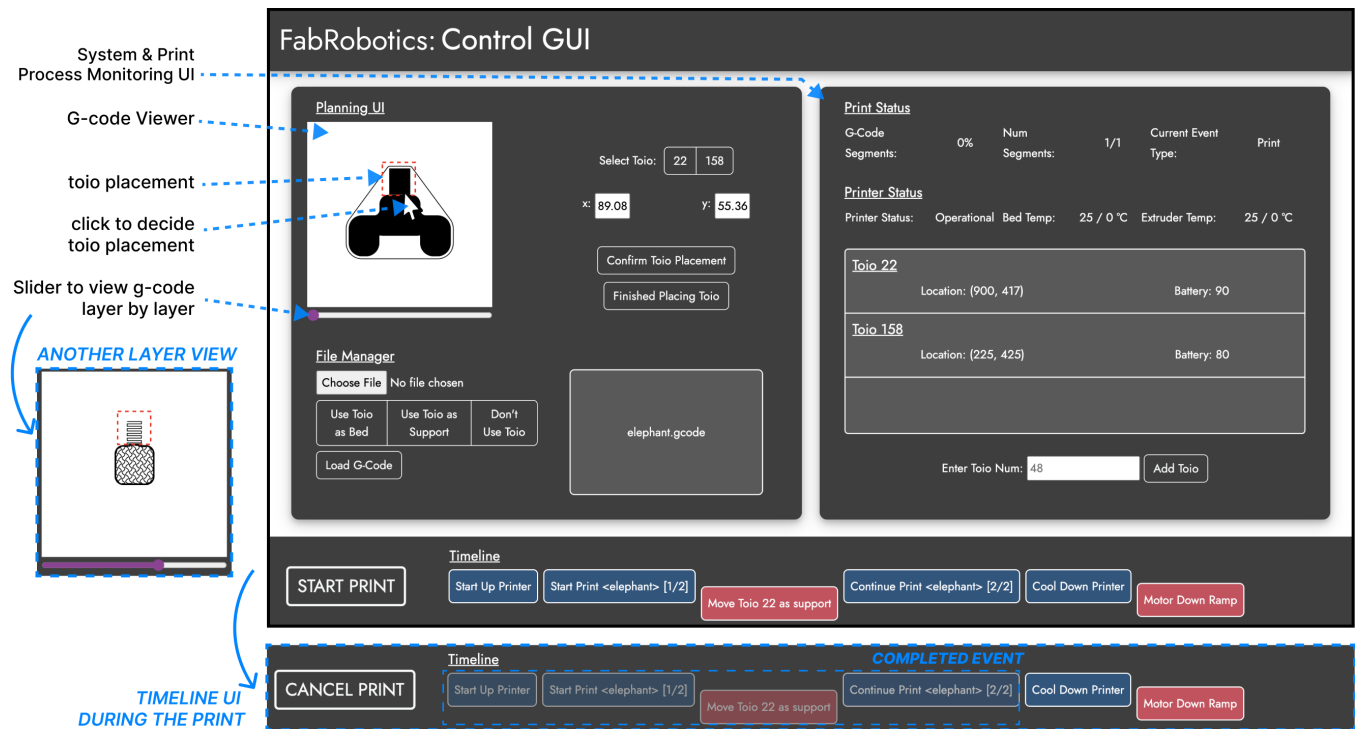

Figure 6: GUI Tool to control the FabRobotics system.

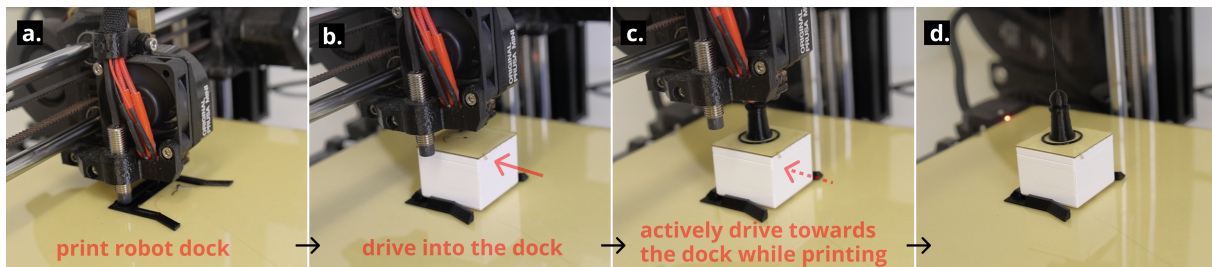

Figure 7: Printing sequence for standard 'printing on top of toio' using a robot dock. (a) shows the robot dock being printed. Immediately after the extruder moves up, and (b) the toio drives into the dock. During printing the toio is (c) constantly driving forward to maintain stability. Finally (d), objects are successfully printed on top of toios.

4.5 Example Timeline Flows

To introduce concrete examples printed with FabRobotics and its workflow, we depict three example timelines in Figure 8. Firstly, (a) shows the timeline generated for printing a simple object on top of a toio. Our second timeline (b) demonstrates how FabRobotics changes when using robots as a support, which decreased print time by 18.03% and decreased filament usage by 10.47%. Lastly, (c) demonstrates how objects can be printed over multiple toios. These timeline events were automatically generated with the GUI control based on user inputs, as described in section 4.2.

4.6 Print Quality Reflections

To preliminarily present the differences in the quality of 3D printing on toio robots vs regular print beds, we compared two of the prints we have made for our prototype; the villain character [3.5 cm height] as in Figure 8 a, and the gripper mechanism [6.6 cm height] as in Figure 8 c.

Figure 9 compares the two 3D print models, printed on toio robot(s) and regular print bed, all printed with the identical Prusa MINI 3D printer. We did not find any significant print quality differences between the villain character and the gripper. However, there were some minor quality differences when using a digital microscope for a close-up view; for example, the villain's head on the left had a very subtle inconsistent print ($<0.25\text{mm}$) [red rectangle in the Figure], and the gripper had small nubs across the

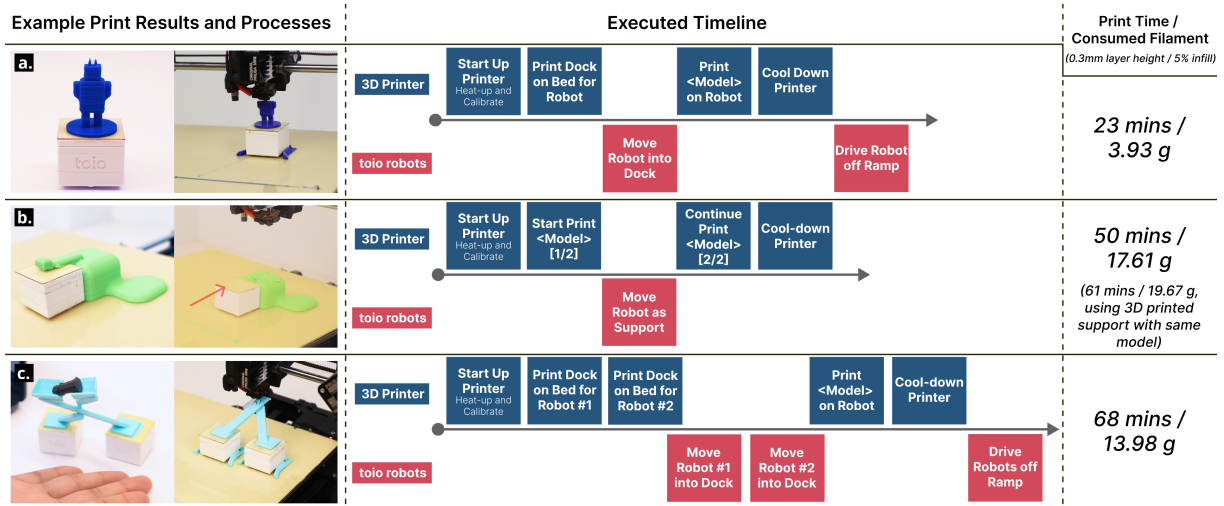

Figure 8: Timelines generated for when a toio is used as a bed (a), as a support (b), and when multiple toios are being printed on (c).

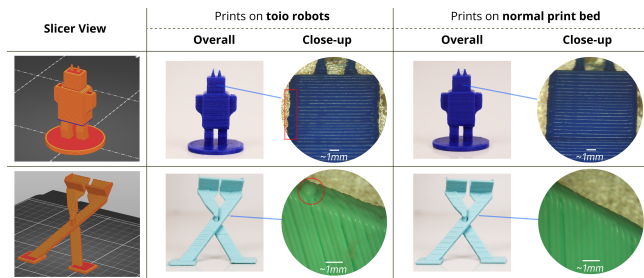

Figure 9: Print quality comparison on toio robots and on the normal print bed for two different models (sliced with 0.3mm layer height and 5% in-fill).

print [red circle in the Figure]. We assume the inconsistency is from the slight instability of toio robots, which could be significant for very tall 3D models. For the nubs, we assume this is caused by how our software segments the G-code for the OctoPrint API, which can compound for larger G-code files, because we only saw such nubs in larger prints. We did not find these issues to be significant for general prints. To further improve future prints, these findings need to be investigated further.

5 POTENTIAL USER SCENARIOS AND APPLICATIONS

In this section, we introduce user scenarios through our proof-of-concept prototype to further demonstrate how the approach and implementation of FabRobotics can be extended to build a tangible, dynamic, and adaptable interactive system. We introduce them as a video prototype – exhibiting mock-up interactions – with the hardware prototype fabricated with our FabRobotics platform. While further implementations would be needed to achieve the illustrated scenarios, we layout technical challenges in each application as well. Rather than showing individual demonstration prints, this

section introduces how the system as a whole could be applied to interactive user scenarios.

5.1 Gaming and Storytelling with In-situ Printed Characters

Utilizing FabRobotics, custom shapes can be fabricated onto mobile robots in situ, enabling the printing of expressive characters or items in tangible storytelling or gaming applications. The hybrid system in Figure 10 empowers users to dynamically create tangible characters in real-time based on their choices, amplifying the Game Master’s storytelling abilities and providing new experiences through robot interactions on the tabletop.

Table-top games, such as Dungeons and Dragons [1], often combine mini-figurines and storytelling for gameplay. However, acquiring relevant mini-figurines for every possible narrative branch can be time-consuming and expensive. The automatic fabrication process of Fabrobotics addresses this issue by allowing players to influence the narrative through printed characters while the game continues.

Figure 10 illustrates the process: (a) The Game Master selects characters for fabrication on the tablet. (b) The figures are printed in real-time during gameplay. (c) The characters appear on the game field. (d) The in-situ printed character/toio hybrids interact expressively, adding immersion and excitement to the experience.

While printing time making people wait remains a challenge, the gap of printing time could be filled by compensating user experience design (e.g. making users easier to wait with narrative design) or rapid fabrication methods [17, 41].

5.2 Calendar Syncing TUIs

Our second potential user scenario involves syncing FabRobotics with users’ schedules. Integrating FabRobotics with online calendar systems like the Google Calendar API would enable the system to interpret users’ needs for physical objects. These objects can be

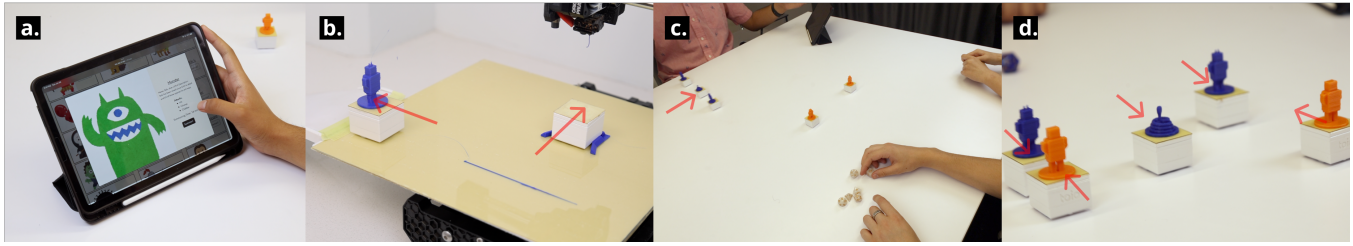

Figure 10: An example of FabRobotics being used in an interactive gaming environment. The user (a) selects characters to ‘summon’, and it begins printing (b). After the prints are complete, the pieces arrive on the game field (c) and begin interacting with each other (d).

printed and delivered to users to provide tangible reminders and practical, physical, and dynamic assistance throughout their day.

While a traditional digital reminder may go unnoticed by a user, a FabRobotics calendar hybrid system can provide tangible reminders, as well as practical tools to assist with day-to-day tasks and even customize items. Figure 11 illustrates such a sequence scenario. In this scenario, the user configures their schedule for the upcoming day (a). Then, they receive helpful items like screwdrivers and storage bowls when they start their specific disassembling tasks in the morning (b). Later on, they are reminded about a deadline through a 3D printed haptic reminder with varying textures on four sides representing different levels of urgency, matching the name of the event [e.g., ‘TEI 2024 deadline’] (c). Finally, before the evening, the user receives a personalized gift for their friend’s party that doubles as a reminder to leave (d).

By seamlessly integrating FabRobotics with calendar schedules, users can experience enhanced productivity and highly personalized assistance in their day-to-day activities, automated based on their plan. While the system for interpreting calendar events to provide adaptive 3D models could be a challenge, it could be achieved by integrating AI-based interpretation and generation system [22] into the FabRobotics pipeline.

6 LIMITATIONS AND FUTURE WORK

Having developed an implementation of a pipeline that integrates 3D printing with mobile robots, there exist various technical limitations within the FabRobotics system that hinder its capabilities and open up potential avenues for future work. This section discusses the limitations of the current prototype, as well as future opportunities, including the extended prototype we have developed during our research process.

6.1 Extended Prototype of Two 3D Printers

As discussed in the design space examples (Figure 4 a-2 and 3), some of the design space elements were preliminary explored with our extended prototype of two 3D printer setups (Figure 12 a). While our proof-of-concept implementation (as in section 4) only explored a single printer setup with automated timeline management control, this two-printer setup allowed us to manually control the robots to locomote between each printer’s print bed, with manually modified G-code commands. While we found great potential in enabling unique capabilities by transferring mobile robots between

two printers, the core implementation of this paper focused on enabling automated control with a single printer.

Future work includes building the automated control with a more complex setup to include additional printers so it can manage the timeline with more complex control, such as parallel printing management, etc. By syncing multiple printers, new application opportunities should arise as well, such as making remote tangible interfaces synchronized with the same (3D-printed) shape and (robotic) motion, as shown in Figure 12 b.

6.2 Hardware Updates

Employing and controlling more robots: Our system only managed up to two mobile robots on the print bed simultaneously. Future systems could support more robots to extend the functionality of FabRobotics. For example, multiple robots could be tiled horizontally to make larger support structures for 3D printing or stacked vertically to make more flexible height supports. Handling a swarm of robots would also enhance serial multi-print capability. Employing more robots could also enable multi-DoF (Degree of Freedom) robotic applications. As a technical challenge, to enable more robots to be controlled simultaneously on a print bed, it is important to employ multi-agent path planning control in our system [30].

Releasing 3D prints from Robots: To repetitively print on toio robots, we could explore automatically removing 3D prints from the robots, as we currently remove them manually. We have explored embedding linear actuators atop each toio (as in [19]) to push prints off it; however, insufficient torque in the current design has not yielded consistent success. We anticipate that future work improving this design could successfully detach structures printed onto robots, which opens up fully automated continuous print opportunities to ‘overwrite’ mobile robots’ physical functionalities.

Recycling: While using a 3D printer to print directly onto robots may afford on-demand interactions in near-real-time, the specificity of the applications means that prints will likely be discarded after use. Future work could explore using recyclable filament and coordinate toios to discard and push used prints into a disposal bin for later recycling and reuse. Alternatively, we could investigate combining our system with work like ReForm [37] to automatically subtract the material before re-printing new features.

Charging docks: The toio robots’ batteries lasted at least 3 hours during our test prints, which was more than enough for the prints we presented in our paper. However, as larger 3D prints can

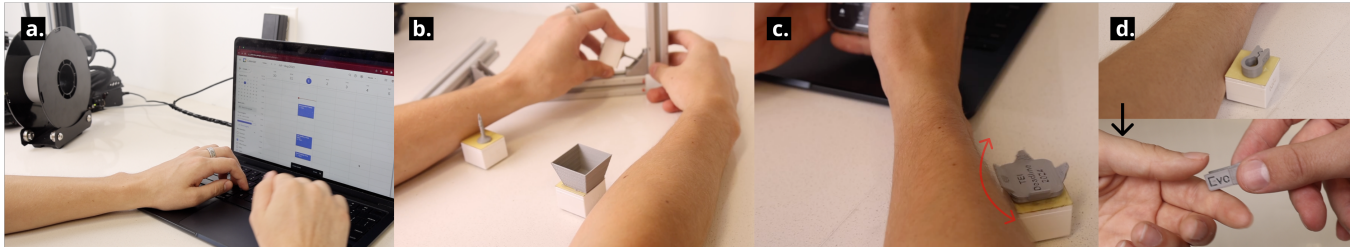

Figure 11: An example of FabRobotics syncing with a user’s personalized calendar events. (a) A user setting up their schedule, (b) receiving relevant tools for a task, (b) a haptic reminder for an upcoming deadline, that prods the user with one of four increasingly sharp sides based on urgency, and (d) a personalized gift that also serves as a reminder to leave for a birthday party.

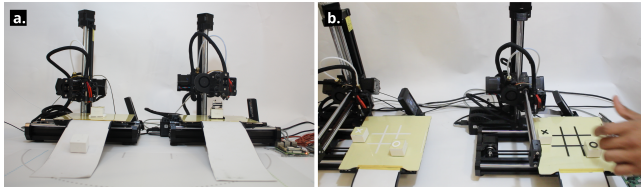

Figure 12: (a) Our extended prototype with two-3D-printer setup, (b) Potential application using multiple 3D printer with remotely synced tangible UI setup.

take much more time, the battery issue needs to be addressed in the future. Enabling wireless charging on the print bed may be one technical solution, but not to waste too much electricity, there could be other solutions (e.g., locking mechanism) to reduce the power consumption for the toio robots while making sure robots adhere to print bed firmly for stable printing, to prevent wasting energy during the printing stage.

Adding Sensors or Cameras: There are numerous sensors and small devices we could attach to toios to further explore the applications of FabRobotics. Firstly, cameras can be added so that a toio can rotate around the printer and show print quality from specific angles and directions. Furthermore, built-in sensors such as accelerometers could be used to detect the vibration that the robot undergoes during the printing process. This sensor could eliminate the need to constantly drive the robot forward for stabilization, thus saving power and allowing more control over the toio.

6.3 Alternative Hardware for Robots/3D Printers

Our approach could be applied to other types of hardware design of robots and 3D printers. For example, as locomotive robots are developed in a wide range of scales, it would be valuable to explore FabRobotics’s setup with furniture or human-scale robots, combined with room- or architecture-scale 3D printers [9]. Exploring the fusion of 3D printers and robotics with different form factors would advance the versatility of robots. For example, humanoid robots could update their feet or hands for extended locomotion, and manipulations. Future Swarm UI hardware could also leverage vertically aligned linear actuators, such as those in Shapebots [31], to dynamically support overhangs at various heights.

In addition, other printers could potentially expand the capabilities of FabRobotics. We could use printers with multiple nozzles or duel extrusions such as IDEX (a printer with two independently moving extruders). Furthermore, by using a printer with a fixed bed, such as CoreXY kinematics, we could have robots enter the print area during a print, which could present some interesting advancements to our work.

6.4 Further Functionalities and Interaction Design

Object detection: In initial experiments, we leveraged toio’s built-in collision detection to detect the presence of foreign objects on the toio mat by recording the locations where collisions occur, and pushing these objects using toios. The advantage of this method is that it leverages the existing infrastructure for object detection, requiring no additional hardware cost or complexity. However, this method can currently only crudely render objects’ shapes, and only do so using the shape of an object at the height of the toios. Future work could explore probabilistic methods such as Kalman filters to advance this method to create higher quality object detections for use in real in-the-wild scenarios. Using toio’s collision detection could allow for automatic failure warnings for scenarios where toios no longer sense pressure from the extruder, or they are no longer parallel to the ground.

Mitigating Printing Time as an Interactive System: While our paper discussed potential user scenarios, where FabRobotics becomes part of an interaction system, it is important for the interactive contents to be designed with regard to the printing time. For example, summoning characters can take more than 20 minutes to print. It is important to seek to integrate rapid fabrication techniques [17, 41] into FabRobotics, and also come up with a user interaction design to minimize the frustration of users while waiting for the print.

Assistive Mobility: Building off the assistive fabrication capabilities of FabRobotics, we could expand upon how the toio could be used for positioning and assembly of objects for individuals with fine motor control disabilities.

7 CONCLUSION

This paper proposed FabRobotics, a digital fabrication pipeline fusing traditional 3D printing with mobile robots. We demonstrated how this can be accomplished by contributing a compatible set of

hardware requirements, and a control pipeline, including a GUI tool for users to instruct the hybrid turn-taking timeline control, and unified software architectures. Fabrication techniques and hardware modifications specific to the approach of fusing a 3D printer and mobile robots were introduced as well. We showed how together, these can be used for new opportunities where robots assist fabrication, 3D printers can assist robots to adapt to tasks, and where users are supported with novel input-output modalities to interact directly with both 3D printers and robots for tangible interactions. We introduced potential user scenarios that lay out opportunities of FabRobotics to be applied to interactive use cases. We believe this paper is a first step toward fusing two rapidly evolving technologies, 3D printing, and mobile robots, to leverage the unique advantages of each and open up new avenues across both areas.

ACKNOWLEDGMENTS

We thank the MIT Portugal Program for the support of this work. We also thank Anup Sathya and Willa Yang for proofreading the paper.

REFERENCES

- [1] [n.d.]. Dungeons & Dragons (last accessed August 1, 2023). <https://dnd.wizards.com/>
- [2] [n.d.]. Flask (last accessed August 1, 2023). <https://flask.palletsprojects.com/en/2.3.x/>
- [3] [n.d.]. Monoprice (last accessed August 1, 2023). https://www.monoprice.com/pages/3d_printers
- [4] [n.d.]. OctoPrint (last accessed August 1, 2023). <https://octoprint.org/>
- [5] [n.d.]. PrusaMini (last accessed August 1, 2023). <https://www.prusa3d.com/category/original-prusa-mini/>
- [6] [n.d.]. Toio (last accessed August 1, 2023). <https://www.sony.com/en/SonyInfo/design/stories/toio/>
- [7] Phillip Chesser, Brian Post, Alex Roschli, Charles Carnal, Randall Lind, Michael Borish, and Lonnie Love. 2019. Extrusion control for high quality printing on Big Area Additive Manufacturing (BAAM) systems. *Additive Manufacturing* 28 (2019), 445–455.
- [8] Wei Gao, Yunbo Zhang, Diogo C Nazzetta, Karthik Ramani, and Raymond J Cipra. 2015. RevoMaker: Enabling multi-directional and functionally-embedded 3D printing using a rotational cuboidal platform. In *Proceedings of the 28th annual ACM symposium on user interface software & technology*. 437–446.
- [9] Clément Gosselin, Romain Duballet, Ph Roux, Nadja Gaudillière, Justin Dirrenberger, and Ph Morel. 2016. Large-scale 3D printing of ultra-high performance concrete—a new processing route for architects and builders. *Materials & Design* 100 (2016), 102–109.
- [10] Yu Jin, Harry A Pierson, and Haitao Liao. 2019. Toolpath allocation and scheduling for concurrent fused filament fabrication with multiple extruders. *IIEE Transactions* 51, 2 (2019), 192–208.
- [11] Hiroki Kaimoto and Samin Farajian. 2022. Swarm Fabrication: Reconfigurable 3D Printers and Drawing Plotters Made of Swarm Robots. (2022).
- [12] Shohei Katakura, Yuto Kuroki, and Keita Watanabe. 2019. A 3D printer head as a robotic manipulator. In *Proceedings of the 32nd Annual ACM Symposium on User Interface Software and Technology*. 535–548.
- [13] Mathieu Le Goc, Lawrence H. Kim, Ali Parsaei, Jean-Daniel Fekete, Pierre Dragicevic, and Sean Follmer. 2016. Zooids: Building Blocks for Swarm User Interfaces. In *Proceedings of the 29th Annual Symposium on User Interface Software and Technology (Tokyo, Japan) (UIST '16)*. Association for Computing Machinery, New York, NY, USA, 97–109. <https://doi.org/10.1145/2984511.2984547>
- [14] Mathieu Le Goc, Charles Perin, Sean Follmer, Jean-Daniel Fekete, and Pierre Dragicevic. 2018. Dynamic composite data physicalization using wheeled micro-robots. *IEEE transactions on visualization and computer graphics* 25, 1 (2018), 737–747.
- [15] Ting-Han Lin, Willa Yunqi Yang, and Ken Nakagaki. 2023. ThrowIO: Actuated TUIs that Facilitate “Throwing and Catching” Spatial Interaction with Overhanging Mobile Wheeled Robots. In *Proceedings of the 2023 CHI Conference on Human Factors in Computing Systems*. 1–17.
- [16] Stefanie Mueller, Martin Fritzsche, Jan Kossmann, Maximilian Schneider, Jonathan Striebel, and Patrick Baudisch. 2015. Scotty: Relocating physical objects across distances using destructive scanning, encryption, and 3D printing. In *Proceedings of the Ninth International Conference on Tangible, Embedded, and Embodied Interaction*. 233–240.
- [17] Stefanie Mueller, Sangha Im, Serafima Gurevich, Alexander Teibrich, Lisa Pfisterer, François Guimbretière, and Patrick Baudisch. 2014. WirePrint: 3D printed previews for fast prototyping. In *Proceedings of the 27th annual ACM symposium on User interface software and technology*. 273–280.
- [18] Stefanie Mueller, Anna Seufert, Huaishu Peng, Robert Kovacs, Kevin Reuss, François Guimbretière, and Patrick Baudisch. 2019. FormFab: continuous interactive fabrication. In *Proceedings of the Thirteenth International Conference on Tangible, Embedded, and Embodied Interaction*. 315–323.
- [19] Ken Nakagaki, Joanne Leong, Jordan L Tappa, João Wilbert, and Hiroshi Ishii. 2020. HERMITS: Dynamically Reconfiguring the Interactivity of Self-Propelled TUIs with Mechanical Shell Add-ons. In *Proceedings of the 33rd Annual ACM Symposium on User Interface Software and Technology*. 882–896.
- [20] Ken Nakagaki, Jordan L Tappa, Yi Zheng, Jack Forman, Joanne Leong, Sven Koenig, and Hiroshi Ishii. 2022. (Dis) Appearables: A Concept and Method for Actuated Tangible UIs to Appear and Disappear based on Stages. In *CHI Conference on Human Factors in Computing Systems*. 1–13.
- [21] Martin Nisser, Christina Chen Liao, Yuchen Chai, Aradhana Adhikari, Steve Hodges, and Stefanie Mueller. 2021. LaserFactory: A Laser Cutter-Based Electromechanical Assembly and Fabrication Platform to Make Functional Devices & Robots. Association for Computing Machinery, New York, NY, USA. <https://doi.org/10.1145/3411764.3445692>
- [22] OpenAI. [n.d.]. Point-e (last accessed August 1, 2023). <https://openai.com/research/point-e>
- [23] Huaishu Peng, Jimmy Briggs, Cheng-Yao Wang, Kevin Guo, Joseph Kider, Stefanie Mueller, Patrick Baudisch, and François Guimbretière. 2018. RoMA: Interactive fabrication with augmented reality and a robotic 3D printer. In *Proceedings of the 2018 CHI conference on human factors in computing systems*. 1–12.
- [24] Laxmi Poudel, Lucas Galvan Marques, Robert Austin Williams, Zachary Hyden, Pablo Guerra, Oliver Luke Fowler, Zhenghui Sha, and Wenchao Zhou. 2022. Toward Swarm Manufacturing: Architecting a Cooperative 3D Printing System. *Journal of Manufacturing Science and Engineering* 144, 8 (2022), 081004.
- [25] Laxmi Poudel, Zhenghui Sha, and Wenchao Zhou. 2018. Mechanical strength of chunk-based printed parts for cooperative 3D printing. *Procedia Manufacturing* 26 (2018), 962–972.
- [26] Thierry Rayna and Ludmila Striukova. 2016. From rapid prototyping to home fabrication: How 3D printing is changing business model innovation. *Technological Forecasting and Social Change* 102 (2016), 214–224.
- [27] Francisco Rubio, Francisco Valero, and Carlos Llopis-Albert. 2019. A review of mobile robots: Concepts, methods, theoretical framework, and applications. *International Journal of Advanced Robotic Systems* 16, 2 (2019), 1729881419839596.
- [28] TaeWoo Seo, Youngjae Jeon, Changmin Park, and Jongwon Kim. 2019. Survey on glass and façade-cleaning robots: Climbing mechanisms, cleaning methods, and applications. *International Journal of Precision Engineering and Manufacturing-Green Technology* 6, 2 (2019), 367–376.
- [29] Hongyao Shen, Lingnan Pan, and Jun Qian. 2019. Research on large-scale additive manufacturing based on multi-robot collaboration technology. *Additive Manufacturing* 30 (2019), 100906.
- [30] Roni Stern, Nathan Sturtevant, Ariel Felner, Sven Koenig, Hang Ma, Thayne Walker, Jiaoyang Li, Dor Atzmon, Liron Cohen, TK Kumar, et al. 2019. Multi-agent pathfinding: Definitions, variants, and benchmarks. In *Proceedings of the International Symposium on Combinatorial Search*, Vol. 10. 151–158.
- [31] Ryo Suzuki, Clement Zheng, Yasuaki Kakehi, Tom Yeh, Ellen Yi-Luen Do, Mark D Gross, and Daniel Leithinger. 2019. Shapebots: Shape-changing swarm robots. In *Proceedings of the 32nd Annual ACM Symposium on User Interface Software and Technology*. 493–505.
- [32] Haruki Takahashi and Homei Miyashita. 2017. Expressive fused deposition modeling by controlling extruder height and extrusion amount. In *Proceedings of the 2017 CHI Conference on Human Factors in Computing Systems*. 5065–5074.
- [33] Haruki Takahashi, Parinya Punpongson, and Jeeun Kim. 2020. Programmable filament: Printed filaments for multi-material 3D printing. In *Proceedings of the 33rd Annual ACM Symposium on User Interface Software and Technology*. 1209–1221.
- [34] Alexander Teibrich, Stefanie Mueller, François Guimbretière, Robert Kovacs, Stefan Neubert, and Patrick Baudisch. 2015. Patching physical objects. In *Proceedings of the 28th Annual ACM Symposium on User Interface Software & Technology*. 83–91.
- [35] Tomomasa Wakimoto, Ryoma Takamori, Soya Eguchi, and Hiroya Tanaka. 2018. Growable Robot with ‘Additive-Additive-Manufacturing’. In *Extended Abstracts of the 2018 CHI Conference on Human Factors in Computing Systems*. 1–6.
- [36] Ludwig Wilhelm Wall, Alec Jacobson, Daniel Vogel, and Oliver Schneider. 2021. Scrapy: Using Scrap Material as Infill to Make Fabrication More Sustainable. In *Proceedings of the 2021 CHI Conference on Human Factors in Computing Systems (Yokohama, Japan) (CHI '21)*. Association for Computing Machinery, New York, NY, USA, Article 665, 12 pages. <https://doi.org/10.1145/3411764.3445187>
- [37] Christian Weichel, John Hardy, Jason Alexander, and Hans Gellersen. 2015. Re-Form: integrating physical and digital design through bidirectional fabrication. In *Proceedings of the 28th Annual ACM Symposium on User Interface Software & Technology*. 93–102.

- [38] J. Werfel, K. Petersen, and R. Nagpal. 2014. Designing collective behavior in a termite-inspired robot construction team. *Science* 343, 6172 (2014), 754–758.
- [39] Karl DD Willis, Cheng Xu, Kuan-Ju Wu, Golan Levin, and Mark D Gross. 2010. Interactive fabrication: new interfaces for digital fabrication. In *Proceedings of the fifth international conference on Tangible, embedded, and embodied interaction*. 69–72.
- [40] Yang Xu, Ziqi Wang, Siyu Gong, and Yong Chen. 2021. Reusable support for additive manufacturing. *Additive Manufacturing* 39 (2021), 101840.
- [41] Junichi Yamaoka and Yasuaki Kakehi. 2017. ProtoMold: An interactive vacuum forming system for rapid prototyping. In *Proceedings of the 2017 CHI Conference on Human Factors in Computing Systems*. 2106–2115.
- [42] Lilith Yu, Chenfeng Gao, David Wu, and Ken Nakagaki. 2023. AeroRigUI: Actuated TUIs for Spatial Interaction using Rigging Swarm Robots on Ceilings in Everyday Space. In *Proceedings of the 2023 CHI Conference on Human Factors in Computing Systems*. 1–18.
- [43] Leijian Yu, Erfu Yang, Peng Ren, Cai Luo, Gordon Dobie, Dongbing Gu, and Xiutian Yan. 2019. Inspection robots in oil and gas industry: a review of current solutions and future trends. In *2019 25th International Conference on Automation and Computing (ICAC)*. IEEE, 1–6.
- [44] Y. Zhao, Lawrence H. Kim, Y. Wang, M. Le Goc, and S. Follmer. 2017. Robotic assembly of haptic proxy objects for tangible interaction and virtual reality. In *Proc. of ISS '17*. ACM, 82–91.