

**BASIC RESEARCH, APPLIED RESEARCH, AND INNOVATION IN THE  
SEMICONDUCTOR AND PHARMACEUTICAL INDUSTRIES**

by

**KWANGHUI LIM**

B.Eng. (Electrical), National University of Singapore

Submitted to the Alfred P. Sloan School of Management  
In Partial Fulfillment of the Requirements for the Degree of

**DOCTOR OF PHILOSOPHY**

at the

**MASSACHUSETTS INSTITUTE OF TECHNOLOGY**

August 2000

© 2000 Kwanghui Lim. All Rights Reserved.

The author hereby grants to MIT permission to reproduce and to distribute publicly paper  
and electronic copies of this thesis document in whole or in part.

Signature of Author \_\_\_\_\_  
MIT Sloan School of Management  
August 2000

Certified by \_\_\_\_\_  
Scott Stern  
Assistant Professor  
Thesis Supervisor

Accepted by \_\_\_\_\_  
Birger Wernerfelt  
Chairman, Ph.D. Program, Sloan School of Management



# **BASIC RESEARCH, APPLIED RESEARCH AND INNOVATION IN THE SEMICONDUCTOR AND PHARMACEUTICAL INDUSTRIES**

by

**KWANGHUI LIM**

Submitted to the Alfred P. Sloan School of Management  
On August 25, 2000  
in Partial Fulfillment of the Requirements for the Degree of  
DOCTOR OF PHILOSOPHY

## **ABSTRACT**

This thesis comprises three essays on the relationships among basic research, applied research, and innovation. Earlier research emphasized that absorbing external knowledge requires effort and investment (Cohen and Levinthal, 1989; 1990). This thesis explores various mechanisms through which absorptive capacity is developed, including a firm's R&D, its connectedness to the external scientific community, the provision of a science-oriented research environment, and investment in basic research. The chief contribution of this dissertation is to document the many ways in which firms develop absorptive capacity, and how absorptive capacity varies across industry, stage of technology development, and scientific area.

The first essay explores how firms develop different kinds of absorptive capacity. A firm's absorptive capacity depends upon internal R&D and its connectedness to universities, other firms and R&D consortia. R&D is effective for absorbing disciplinary knowledge; alternative mechanisms are useful for domain-specific knowledge. A science-oriented research environment is not necessary, as long as the firm remains connected through other means. To illustrate, I trace knowledge spillovers of copper interconnect technology for semiconductors.

The second essay examines the concentration of basic and applied research *relative* to innovation. In the semiconductor industry, basic research is surprisingly concentrated relative to innovation. Since spillovers are prevalent in this industry, I conclude that many semiconductor firms capture spillovers without performing much basic research. In the pharmaceutical industry, basic research and innovation have similar concentrations. In both industries, applied research is not concentrated relative to innovation.

The third essay examines researchers at five firms. Given two researchers with the same number of publications at IBM, AT&T, or Intel, the one who publishes a higher fraction of her papers in basic research journals is *less* likely to patent. These researchers face a tradeoff between participating in basic and applied research (Allen, 1977). The opposite holds at Merck and DuPont, where researchers who publish a higher fraction of papers in basic scientific journals obtain *more* patents. Thus, basic research has a positive impact on pharmaceutical patents (Gambardella, 1992; Cockburn and Henderson, 1998). Within Dupont and Merck, patenting is most closely associated with publications in basic *chemistry*, and with pharmaceutical R&D.

Thesis Committee: Scott Stern (Chair)  
Assistant Professor  
Alfred P. Sloan School of Management, MIT

Rebecca Henderson  
Eastman Kodak LFM Professor of Management  
Alfred P. Sloan School of Management, MIT

Eric von Hippel  
Professor, Management of Innovation  
Alfred P. Sloan School of Management, MIT

## TABLE OF CONTENTS

<b>LIST OF FIGURES</b> .....	<b>9</b>
<b>LIST OF TABLES</b> .....	<b>11</b>
<b>ACKNOWLEDGEMENTS</b> .....	<b>13</b>
<b>CHAPTER 1:INTRODUCTION</b> .....	<b>15</b>
1.1 OVERVIEW AND MOTIVATION.....	15
1.2 RESEARCH QUESTIONS AND FINDINGS.....	17
1.3 CONTRIBUTIONS TO THE LITERATURE .....	22
<b>CHAPTER 2:THE MANY FACES OF ABSORPTIVE CAPACITY: SPILLOVERS OF COPPER INTERCONNECT TECHNOLOGY FOR SEMICONDUCTOR CHIPS</b> .....	<b>27</b>
2.1 INTRODUCTION.....	27
2.2 THE DETERMINANTS OF ABSORPTIVE CAPACITY .....	31
2.3 METHODOLOGY .....	35
2.3.1 <i>Research Setting</i> .....	35
2.3.2 <i>Research Method and Data</i> .....	37
2.3.3 <i>Copper Interconnect Technology and the Skills Upon Which it Depends</i> .....	39
2.4 THE COPPER PUZZLE .....	44
2.4.1 <i>Firms Depended On External Knowledge, Primarily from IBM</i> .....	46
2.4.2 <i>Prior R&amp;D is Insufficient to Account for Absorptive Capacity</i> .....	53
2.4.3 <i>Absorptive Capacity Depends upon Connectedness</i> .....	60
2.4.3.1 Spillovers before 1997.....	60
2.4.3.2 Knowledge Spillovers after 1997 .....	68
2.5 DISCUSSION.....	75
2.5.1 <i>Other Factors that Affected Adoption</i> .....	76
2.5.2 <i>Why did IBM innovate and why did the Firm Publish?</i> .....	78
2.5.3 <i>IBM's Dependence on Disciplinary Spillovers</i> .....	80
2.6 CONCLUSIONS.....	81
APPENDIX 2-A: CONSTRUCTION OF DATA SET .....	84
<b>CHAPTER 3:THE CONCENTRATION OF BASIC AND APPLIED RESEARCH IN THE SEMICONDUCTOR AND PHARMACEUTICAL INDUSTRIES: IMPLICATIONS FOR THEORIES OF KNOWLEDGE SPILLOVERS</b> .....	<b>89</b>

3.1	INTRODUCTION .....	89
3.2	THE ECONOMICS OF SCIENTIFIC RESEARCH AND INNOVATION.....	92
3.3	EMPIRICAL METHODOLOGY .....	94
3.3.1	<i>Concentration Indices</i> .....	97
3.3.2	<i>Measuring Basic Research, Applied Research and Innovation</i> .....	100
3.4	DATA.....	101
3.4.1	<i>Sample Construction</i> .....	101
3.4.2	<i>Data on Patenting Activity</i> .....	102
3.4.3	<i>Data on Scientific Publications</i> .....	104
3.4.4	<i>Data on Co-authorship with Academic Researchers</i> .....	106
3.5	RESULTS.....	108
3.5.1	<i>Main Results</i> .....	109
3.5.2	<i>Robustness Tests</i> .....	117
3.5.3	<i>Limitations</i> .....	118
3.6	DISCUSSION .....	119
3.6.1	<i>An Analytical Framework</i> .....	120
3.6.2	<i>Semiconductors versus Pharmaceuticals</i> .....	123
3.6.3	<i>Changes In the Concentration of Basic Research Over Time</i> .....	124
3.7	CONCLUSION .....	127
	APPENDIX 3-A: LIST OF FIRMS IN THE SAMPLE .....	128
	APPENDIX 3-B: ROBUSTNESS OF THE RESULTS TO JOURNAL CLASSIFICATION SCHEMES.....	129

**CHAPTER 4:PUBLISHING AND PATENTING: RESEARCHER-LEVEL EVIDENCE FROM FIVE COMPANIES ..... 135**

4.1	INTRODUCTION .....	135
4.2	THE RELATIONSHIP BETWEEN PUBLICATIONS AND PATENTS.....	139
4.3	METHODOLOGY .....	143
4.4	DATA.....	147
4.4.1	<i>Identifying the Inventors and Authors of each Firm</i> .....	148
4.4.2	<i>Matching the Abbreviated Names of Authors and Inventors</i> .....	149
4.4.3	<i>The Results of the Algorithms to Identify and Match Authors and Inventors</i> .....	151
4.5	RESULTS AND DISCUSSION.....	152
4.5.1	<i>Descriptive Statistics</i> .....	152
4.5.2	<i>Regression Results</i> .....	154
4.5.3	<i>Firm Effects and Scientific Disciplines</i> .....	158
4.5.4	<i>Limitations and Sources of Bias</i> .....	162
4.6	CONCLUSIONS.....	163

APPENDIX 4-A: ALGORITHM FOR MATCHING AUTHORS AND INVENTORS.....	165
<b>BIBLIOGRAPHY .....</b>	<b>169</b>
<u>ECONOMICS AND MANAGEMENT .....</u>	<u>169</u>
<u>COPPER INTERCONNECT TECHNOLOGY .....</u>	<u>175</u>





## LIST OF FIGURES

FIGURE 2-1: SEMICONDUCTOR CHIP WITH COPPER INTERCONNECTS.....	29
FIGURE 2-2: ABSORPTIVE CAPACITY AS A FUNCTION OF CONNECTEDNESS .....	33
FIGURE 2-3: COPPER DAMASCENE VERSUS ETCH PROCESS.....	40
FIGURE 2-4: NUMBER OF U.S. PATENTS RELATED TO COPPER INTERCONNECT PER YEAR.....	54
FIGURE 2-5: NUMBER OF ARTICLES PER YEAR ON COPPER INTERCONNECTS.....	54
FIGURE 2-6: NUMBER OF COPPER PATENTS VERSUS NUMBER OF COPPER PUBLICATIONS.....	59
FIGURE 3-1: SEMICONDUCTOR FIRMS- NUMBER OF RELEVANT PATENTS VERSUS NUMBER OF BASIC RESEARCH ARTICLES (1985-1997).....	111
FIGURE 3-2: PHARMACEUTICAL FIRMS- NUMBER OF RELEVANT PATENTS VERSUS NUMBER OF BASIC RESEARCH ARTICLES (1985-1997).....	111
FIGURE 3-3: SEMICONDUCTOR FIRMS- C4 INDEX OF BASIC RESEARCH, APPLIED RESEARCH AND INNOVATION .....	112
FIGURE 3-4: PHARMACEUTICAL FIRMS- C4 INDEX OF BASIC RESEARCH, APPLIED RESEARCH AND INNOVATION .....	112
FIGURE 3-5: SEMICONDUCTOR FIRMS- HERFINDAHL INDEX OF BASIC RESEARCH, APPLIED RESEARCH AND INNOVATION .....	113
FIGURE 3-6: PHARMACEUTICAL FIRMS- HERFINDAHL INDEX OF BASIC RESEARCH, APPLIED RESEARCH AND INNOVATION .....	113
FIGURE 3-7: SEMICONDUCTOR FIRMS- HERFINDAHL INDEX OF ARTICLES CO-AUTHORED WITH ACADEMIC RESEARCHERS.....	114
FIGURE 3-8: PHARMACEUTICAL FIRMS- HERFINDAHL INDEX OF ARTICLES CO-AUTHORED WITH ACADEMIC RESEARCHERS.....	114
FIGURE 3-9: SEMICONDUCTOR FIRMS- GAMMA FOR BASIC RESEARCH AND APPLIED RESEARCH RELATIVE TO INNOVATION .....	115
FIGURE 3-10: PHARMACEUTICAL FIRMS- GAMMA FOR BASIC RESEARCH AND APPLIED RESEARCH RELATIVE TO INNOVATION .....	115
FIGURE 3-11: HYPOTHESIZED RELATIONSHIP BETWEEN A FIRM’S BASIC RESEARCH AND ITS ABSORPTION OF EXTERNAL RESEARCH .....	121
FIGURE 3-12: TOP SEMICONDUCTOR FIRMS- NUMBER OF ARTICLES IN JOURNALS WITH JCRBAS=1 .....	125
FIGURE 3-13: TOP PHARMACEUTICAL FIRMS- NUMBER OF ARTICLES IN JOURNALS WITH JCRBAS=1 .....	125
FIGURE 3-14: SEMICONDUCTOR FIRMS- GAMMA OF NUMBER OF BASIC RESEARCH ARTICLES RELATIVE TO INNOVATION.....	133
FIGURE 3-15: PHARMACEUTICAL FIRMS- GAMMA OF NUMBER OF BASIC RESEARCH ARTICLES RELATIVE TO INNOVATION.....	133
FIGURE 4-1: MATCHING AUTHORS TO INVENTORS.....	166

FIGURE 4-2: TYPES OF NODES..... 167

## LIST OF TABLES

TABLE 1-1: SUMMARY OF THE THREE ESSAYS .....	18
TABLE 2-1: PRIOR R&D RELEVANT TO COPPER INTERCONNECTS VERSUS YEAR OF FIRST SHIPMENT .....	45
TABLE 2-2: NUMBER OF CITATIONS BY COPPER INTERCONNECT PATENTS TO ALL OTHER PATENTS.....	49
TABLE 2-3: NUMBER OF CITATIONS BY COPPER INTERCONNECT PATENTS TO COPPER PATENTS.....	50
TABLE 2-4: CITATIONS BY U.S. PATENTS ON COPPER INTERCONNECTS TO SCIENTIFIC ARTICLES. ....	52
TABLE 2-5: NUMBER OF PUBLICATIONS ON COPPER INTERCONNECTS PER YEAR BY COMPANIES.....	55
TABLE 2-6: NUMBER OF PATENTS ON COPPER INTERCONNECT PER YEAR .....	56
TABLE 2-7: NUMBER OF PUBLICATIONS ON COPPER INTERCONNECTS PER YEAR BY THE TOP 10 UNIVERSITIES AND GOVERNMENT LABORATORIES.....	61
TABLE 2-8: PATENTS MOST HIGHLY CITED BY COPPER INTERCONNECT PATENTS (1960-1999).....	67
TABLE 2-9: COPPER ALLIANCES, JOINT VENTURES, AND ACQUISITIONS AMONG SEMICONDUCTOR FIRMS...	69
TABLE 2-10: COPPER ALLIANCES, JOINT VENTURES, AND ACQUISITIONS INVOLVING SUPPLIERS .....	70
TABLE 3-1: APPLICATIONS OF THE E-G MODEL .....	98
TABLE 3-2: US PATENT CLASSES RELEVANT TO EACH INDUSTRY .....	103
TABLE 3-3: CLASSIFICATION OF JOURNAL CATEGORIES INTO “BASIC” AND “APPLIED” .....	105
TABLE 3-4: SUMMARY STATISTICS (ALL FIRMS, 1985-1997).....	107
TABLE 3-5: DESCRIPTIVE STATISTICS.....	108
TABLE 3-6: OLS (DEPENDENT VARIABLE IS THE NUMBER OF PATENTS PER FIRM PER YEAR) .....	109
TABLE 3-7: OLS WITH FIRM FIXED EFFECTS (DEPENDENT VARIABLE IS NUMBER OF PATENTS PER FIRM PER YEAR).....	109
TABLE 3-8: HYPOTHETICAL SCENARIOS: GAMMA RELATIVE TO THE NUMBER OF RELEVANT PATENTS (1985- 1997).....	116
TABLE 3-9: DESCRIPTIVE STATISTICS OF JOURNAL-LEVEL VARIABLES (ALL JOURNALS IN THE SCI, 1985- 1997).....	129
TABLE 3-10: CORRELATION FOR VARIOUS MEASURES OF BASIC RESEARCH (ALL JOURNALS IN THE SCI, 1985-1997).....	132
TABLE 4-1: SUMMARY STATISTICS FOR EACH COMPANY .....	148
TABLE 4-2: INVENTORS AND AUTHORS IDENTIFIED AND MATCHED IN EACH FIRM .....	151
TABLE 4-3: VARIABLES USED IN THE REGRESSIONS.....	153
TABLE 4-4: PAIRWISE CORRELATION COEFFICIENTS.....	154
TABLE 4-5: OLS WITH NUMBER OF PATENTS AWARDED TO A RESEARCHER AS THE DEPENDENT VARIABLE .....	155
TABLE 4-6: OLS OF PATENTS PER RESEARCHER BY FIRM AND SCIENTIFIC AREA (ROBUST STANDARD ERRORS).....	158

TABLE 4-7: OLS FOR RESEARCHERS WHO RECEIVED PATENTS IN U.S. PATENT CLASSES 424 AND 514  
(DRUGS, BIO-AFFECTING AND BODY TREATING COMPOSITIONS). ..... 161

## ACKNOWLEDGEMENTS

The most difficult change a doctoral candidate must undergo is the mystical transformation from student to a scholar. For this, I am most grateful to Scott Stern, Rebecca Henderson, and Eric von Hippel. They have been more than just my thesis advisors. These past five years, they have been an active part of my intellectual metamorphosis, helping me at each stage to hone the skills needed to journey onward and guiding me through the difficult choices I had to make.

Scott's passion for research and for seeking the truth has inspired in me a desire to do good, enduring work. One of the many important lessons I have learned from Scott is to be unconstrained when approaching research questions and to choose the best approach possible, rather than worrying about perceived obstacles. Rebecca has taught me the importance of a fine sense of balance and to focus on "architectural" issues, for it is how things are combined that really matters, not any individual part. And Eric has been a source of great wisdom, teaching me to see the world for what it truly is and to learn from it rather than simply imposing my own view upon that world.

My colleagues and friends at MIT have also been critical to my transformation. The many sleepless nights I spent with my dear friend Jeff Furman studying for exams and our endless discussions covering every esoteric topic has no doubt left its mark. My officemates (Annabelle Gawer, Lin Xu, and Gao Xudong) brought light and color into what would otherwise have become a windowless prison. Pierre Azoulay never hesitated to spend time with me to offer constructive criticism on my work. I also benefited greatly from the rich discussions with David Hsu and Ajay Agrawal, who share similar research passions. Scott Rockart, Maw Der Foo, Pek Hooi Soh, Sonali Shah, Susumu Ogawa, Sandy Rothenberg, and the rest of the BPS doctoral students offered me the comforting intellectual and emotional support of a close-knit group. My friends at MIT have indeed been my "family away from home" these past years.

I would like also to express my deep appreciation to the people who offered comments on the three papers that eventually became this dissertation, including: Glenn Ellison, Lori Rosenkopf, Sam Kortum, Iain Cockburn, Ashish Arora, Dan Levinthal, Fiona Murray, Rakesh Khurana, John de Figueiredo, Richard Nelson, Peter Murmann, Peter Lane, Jaeyong Song, Hank Chesbrough, Gary Pisano, Mike Lennox, Jorgen Pederson, Jordan Siegel, Nicole de Horatius, Lee Fleming and Brent Goldfarb. I also received helpful feedback from the participants in the CCC Doctoral Consortium (1998, 1999), Academy of Management (2000), NBER Productivity Lunches, MIT Innovation Seminar, and SIM Doctoral Lunch, as well as two anonymous referees at Research Policy.

A special word of thanks goes out to my industry contacts whose help made this research possible (although they remain unnamed to protect their identities). They were instrumental in my creation of the case study on copper interconnects, my fieldwork in Silicon Valley, and the numerous telephone interviews I conducted. Charles Weber, Ken van Bree, and Kevin Christiansen were very helpful in setting up some of these contacts. I also thank Diana Hicks of CHI Research for sharing with me valuable data on journal characteristics. The MIT reference librarians (Margaret Lippert and Margo Miller) generously offered access to the Science Citation Index; Jim Testa and Michelle Cooley from ISI helped me with its finer points. My research would not have been possible without the generous financial support of the National University of Singapore.

Scott Cooper spent many hours editing my thesis, transforming my awkward statements into elegant prose.

My deep gratitude extends to my parents and siblings for their love and encouragement, despite our being scattered in five locations across the globe. Finally, I thank my dear wife, Seto Wai Ling, for everything she has put up with these past five years and for her many sacrifices. Her love has made my dreams a reality. The thesis you now read is wrought as much from her blood and tears as from mine.

## Chapter 1: Introduction

This chapter introduces the dissertation, summarizes the key findings and contributions, and provides an organizing framework for the three chapters that follow.

### 1.1 Overview and Motivation

This thesis consists of three essays on the relationship between basic research, applied research, and innovation. I define basic research as research that seeks a fundamental understanding of a problem; applied research is that which seeks useful or practical results.<sup>1</sup> These definitions are similar to those used Bush (1945), Stokes (1997) and by the Organization for Economic Cooperation and Development (OECD).

Research activities within firms, including both applied and basic research, are crucial sources of innovation. However, as Nelson (1959) and Arrow (1962) pointed out, the main output of R&D activities is knowledge, a durable public good. Once a firm has created knowledge, other firms can easily exploit that knowledge without compensating the innovator. Thus, knowledge flows are spillovers. Innovating firms cannot capture the marginal value of the knowledge they produce, and therefore are likely to underinvest in R&D relative to what is socially desired. This problem should be worse for basic research than applied research, for which the expected benefits are highly intangible to a firm.

Nelson and Arrows' seminal papers have spawned a huge literature on knowledge spillovers. Empirical research in this field is exceedingly difficult to perform because knowledge spillovers are, by nature, difficult to observe. The available evidence suggests

---

<sup>1</sup> Other authors have defined “basicness” along other dimensions, including originality, autonomy, peer evaluation of published results, length of time between discovery and use, motivation of researcher, institutional affiliation of researcher, and source of research funding (see Stokes, 1997, chap. 1, for a review).

that (a) spillovers have a positive impact on economic growth<sup>2</sup>; (b) spillovers increase the productivity of firms (Mansfield 1991; Jaffe 1986); (c) spillovers are geographically localized (Jaffe, Trajtenberg and Henderson 1993); and (d) the level of appropriability varies greatly across industries (Levin et. al. 1987). Scholars continue to explore many issues, including how spillovers affect the incentives to innovate, whether governments should fund R&D, and whether research consortia resolve these externalities.

Several researchers have questioned whether knowledge spillovers occur as easily as portrayed by Nelson and Arrow (Rosenberg, 1990; Cohen and Levinthal 1989, 1990). Cohen and Levinthal argue that especially when learning is difficult, firms may need to make internal investments in order to absorb external knowledge. While recognizing that many alternative mechanisms are available, they assign a primary role to internal R&D investments. A firm's prior relevant R&D helps to build "absorptive capacity," which they describe as the "ability to recognize the value of external information, assimilate that information, and then apply it to commercial ends."<sup>3</sup> The need for absorptive capacity arises because knowledge is tacit and highly embedded within organizational routines (Cohen and Levinthal, 1990, pp. 135).

The notion of absorptive capacity is an influential one and has stimulated much research. But because spillovers are hard to observe, the relationship between R&D and absorptive capacity is often *assumed* rather than explored. A consequence of this difficulty is that little theoretical development has occurred beyond the seminal paper of Cohen and Levinthal. How important are alternative mechanisms of building absorptive capacity vis-à-vis R&D? When is internal R&D most effective for building absorptive capacity, and when are alternative mechanisms more effective? Are there different kinds of absorptive capacity, depending on the kinds of mechanisms used?

---

<sup>2</sup> See Griliches (1992) for an excellent survey.

<sup>3</sup> A parallel stream of research on absorptive capacity has existed since the 1960s on the international transfer of technology, but deals with countries rather than firms (see Baranson 1970).



Another issue with the literature on absorptive capacity is that much of the empirical evidence supporting the theory comes from the pharmaceutical and biotechnology industries (Gambardella, 1992; Henderson and Cockburn, 1996; Zucker and Darby, 1995). It would be interesting to learn whether these results are equally applicable in other settings.

Absorptive capacity is sometimes associated with the idea that firms should pursue science-oriented research environments that offer autonomy to researchers (Gambardella, 1992) and promote scientists based on their publications and scientific reputations (Cockburn and Henderson, 1998). These studies suggest that science-oriented research environments allow researchers within the firm to remain *connected* to top scientists in various scientific disciplines, giving them better access to information and thereby boosting their productivity. The relationship between “connectedness” and spillovers is further explored in this dissertation.

## **1.2 Research Questions and Findings**

The central question of this thesis is: how does the ability to assimilate and exploit scientific and technical knowledge developed outside the firm depend on investments in *internal* research, formal connections with the external scientific community, or some combination of these factors. The three essays in this dissertation revolve around this question. Each essay constitutes a separate chapter in this thesis. Table 1-1 provides a summary of the research questions, unit of analysis, and key results of each essay.

The first essay, presented in Chapter 2, explores how absorptive capacity depends upon a firm’s prior R&D and its connectedness to sources of external technical knowledge (Figure 2-2). Firms have many options available for developing connectedness, and consequently, for building absorptive capacity. These include: (1) performing R&D; (2) funding research at universities, maintaining relationships with faculty, and hiring graduate students; (3) forming alliances with companies that possess a

**Table 1-1: Summary of the Three Essays**

	<b>Chapter 2</b>	<b>Chapter 3</b>	<b>Chapter 4</b>
<b>Research Questions</b>	<ul style="list-style-type: none"> <li>▪ How do firms develop absorptive capacity?</li> <li>▪ What accounts for the rapid adoption of copper interconnect technology (which was developed by IBM) by other semiconductor firms?</li> </ul>	<ul style="list-style-type: none"> <li>▪ Is basic research more concentrated than innovation?</li> <li>▪ What about applied research relative to innovation?</li> </ul>	<ul style="list-style-type: none"> <li>▪ What is the relationship between the publications and patents produced by industrial scientists?</li> </ul>
<b>Research Setting</b>	The semiconductor industry.	Two industries with high spillovers: pharmaceuticals and semiconductors.	Five innovative companies: DuPont, Merck, IBM, AT&T, Intel.
<b>Unit of Analysis</b>	An innovation.	A firm.	A researcher.
<b>Research Design</b>	A quantitative and qualitative analysis of knowledge spillovers relating to copper interconnect technology.	An analysis of patents and publications by firms in the semiconductor and pharmaceutical industries.	An econometric analysis of patents and publications by scientists at five companies.
<b>Key Findings</b>	<ul style="list-style-type: none"> <li>▪ Firms used many ways to build absorptive capacity.</li> <li>▪ Apart from R&amp;D, firms depended upon their connectedness to external sources of technical knowledge, including Sematech, universities, equipment suppliers, and other firms that possessed copper technology.</li> </ul>	<ul style="list-style-type: none"> <li>▪ In the semiconductor industry, basic research is surprisingly more concentrated than is innovation.</li> <li>▪ In the pharmaceutical industry, basic research is not more concentrated is innovation.</li> <li>▪ Applied research was not concentrated relative to innovation in either industry.</li> </ul>	<ul style="list-style-type: none"> <li>▪ Scientists at IBM, AT&amp;T, and Intel who published a higher fraction of their articles in basic scientific journals obtained fewer patents</li> <li>▪ The opposite result holds for scientists at Merck and DuPont. This is mainly driven by a relationship between basic chemistry research and pharmaceutical patents.</li> </ul>
<b>Contributions</b>	<ul style="list-style-type: none"> <li>▪ Absorptive capacity is a function of connectedness as well as R&amp;D.</li> <li>▪ Different kinds of knowledge are absorbed depending upon whether firms invest in R&amp;D or alternative means to build absorptive capacity.</li> <li>▪ A science-oriented research environment may not be necessary for building absorptive capacity.</li> </ul>	<ul style="list-style-type: none"> <li>▪ The results suggest that semiconductor companies are able to capture spillovers without performing much basic research.</li> <li>▪ The relationship between basic research and patents is stronger in the pharmaceutical industry than for semiconductors.</li> </ul>	<p>There is a suggestive relationship between basic research and patents at the level of the individual, not just at the level of the firm:</p> <ul style="list-style-type: none"> <li>▪ The relationship is negative outside the pharmaceutical industry.</li> <li>▪ Within pharmaceutical firms, the relationship is positive, but mainly because of basic chemistry.</li> </ul>

given technology; and (4) obtaining membership in research consortia. The alternative methods for building absorptive capacity are at least as important as internal R&D.

I illustrate this framework using a detailed case study of copper interconnect technology, providing an “inside-the-black-box” view of how knowledge spillovers occur.<sup>4</sup> IBM created this important technology over a three-decade period, relying on internal knowledge and secrecy. Other firms invested much less than IBM in copper interconnect R&D, but were able to adopt the technology very quickly by relying on spillovers from IBM and from Sematech-funded universities. Several firms that had performed little R&D were able to adopt the technology faster than were others that had invested more in prior R&D. I show that the rapid adopters enhanced their absorptive capacity by leveraging their connectedness to Sematech, universities, and other firms that had access to copper technology.

While previous authors recognized the relationship between absorptive capacity and connectedness (Powell *et al.*, 1996; Cockburn and Henderson, 1998), my case study clarifies this relationship and the following implications. First, there are different types of absorptive capacity. IBM’s approach of investing heavily in internal R&D was useful for capturing *discipline-level* knowledge. However, other firms that didn’t perform as much R&D were more concerned about acquiring *domain-specific* knowledge, which they absorbed through their relationships with universities and other firms. The mechanisms used for acquiring external knowledge shifted over time, as firms became more concerned about acquiring domain-specific rather than disciplinary knowledge.

Second, the case study shows that a science-oriented research environment may be helpful for keeping up with outside knowledge, but is not essential. IBM in particular was able to keep up with all the external developments in the field although the company was *highly secretive* about its own research. Third, the multiplicity of approaches

---

<sup>4</sup> The illustrative nature of this case study is similar in intent to Nelson’s (1962) study on the development of the transistor and Rosenberg’s (1963) analysis of the machine tools industry.

available to firms for building absorptive capacity implies that knowledge spillovers are difficult to contain. Unless many firms choose R&D as their means for building absorptive capacity, it is unlikely that the underinvestment problem recognized by Arrow and Nelson would be overcome.

The second essay (Chapter 3) examines the relationship between research and innovation in the pharmaceutical and semiconductor industries. It poses whether basic research is more highly concentrated than innovation, and whether applied research is more concentrated than innovation. These industries exhibit high levels of knowledge spillovers (Levin and Reiss, 1988; Mowery, 1983; Appleyard, 1996; Cockburn and Henderson, 1998). To the extent that internal research is a prerequisite for absorptive capacity, we should expect basic research to be clustered within the same firms that produce a large number of innovations.

I find that, in the semiconductor industry, basic research is highly concentrated within IBM and AT&T, while innovation is dispersed across many firms. Firms other than IBM and AT&T produce a surprisingly large number of innovations relative to their basic research. Though several explanations are possible, one potential interpretation is that most semiconductor firms are able to capture spillovers even though they perform little basic research.<sup>5</sup> In the pharmaceutical industry, basic research is *not* appreciably more concentrated than innovation; pharmaceutical firms that produce more basic research are *also* more innovative.

In contrast to basic research, applied research is not more concentrated than innovation in either industry. I reconcile this fact with the results for basic research by speculating that at least in the semiconductor industry, absorptive capacity “scales up” with applied research, but exhibits a threshold effect with respect to basic research. This

---

<sup>5</sup> An alternative explanation is that the other firms are not capturing spillovers, but more productive at translating R&D into innovation. This is unlikely because there is a widespread practice among these companies of co-authoring papers with universities and public-sector laboratories.

threshold represents a “membership fee”, beyond which a firm is able to remain connected to external scientific networks.

Overall, this second essay suggests that basic research is less closely connected to innovation in the semiconductor industry than it is in the pharmaceutical industry. This theme is further explored in my next essay.

The third essay (Chapter 4) examines publishing and patenting by researchers at five R&D-intensive firms (DuPont, Merck, IBM, Intel, and AT&T). A new technique is used to match the inventors of patents to the authors of publications. The essay exploits this technique to test various hypotheses, with the *individual* as the unit of analysis. The results show that researchers at IBM, AT&T, and Intel who published a higher fraction of their papers in basic research journals were *less* likely to obtain patents. This supports the hypothesis that researchers face a tradeoff between pursuing a scientific career (publishing in basic scientific journals) and contributing directly to the firm (producing more patents).

The opposite relationship holds for Merck and DuPont, where scientists who published a higher fraction of papers in basic scientific journals obtained *more* patents. This is consistent with previous research suggesting a positive productivity impact among pharmaceutical firms of participating in basic research (Gambardella, 1992; Cockburn and Henderson, 1998; Zucker and Darby, 1995). My results show that the effect occurs at the level of the individual researcher, not just of the firm as a whole.

Interestingly, the results for Merck and DuPont are driven largely by publications in the field of basic *chemistry*. Even at these pharmaceutical firms, the relationship between basic research and patents is weaker in other scientific fields (including biology). As well, basic research is more closely associated with patents among scientists who work on pharmaceutical R&D than on other areas within these firms. Together, these results imply that even within a firm, the relationship between basic

research and patenting depends upon the scientific field being investigated and the area of application.

Apart from the results on basic research, the analysis also shows that patents across the five firms are positively related to the total number of publications by a researcher (indicating differential individual ability or balanced incentives within firms). However, patents are negatively related to the fraction of articles co-authored by a researcher with academic and public-sector scientists. The latter result is surprising given the importance of connectedness. A likely interpretation is that researchers who co-author with academics and public-sector researchers play the role of gatekeepers, increasing the productivity of other researchers within the firm but not necessarily adding to the number of patents they themselves obtain.

### **1.3 Contributions to the Literature**

This dissertation presents a framework for understanding and clarifying the relationship between absorptive capacity, R&D and connectedness. Although previous research has acknowledged the multi-faceted nature of absorptive capacity, this thesis unpacks its constituent elements, compares alternative drivers of absorptive capacity, and explores when each of these drivers is important relative to the others.

It is tempting to claim this leads directly to a set of managerial prescriptions, but to do so would be to pretend to have a simple fix for a highly complex problem. Rather, the greater benefit is from the change in perspective that results from this understanding. Recognizing the multi-faceted character of absorptive capacity changes R&D from a simple “make versus buy” investment to a more complex *series* of choices. These include the kinds of absorptive capacity a firm wants to develop, its options available for acquiring knowledge, and the relationships it plans to develop with other organizations. Instead of suggesting to all firms seeking to build absorptive capacity that they invest in internal R&D (particularly basic research), we should recommend that they choose from

a broad range of choices— depending on the strategic options and other contingencies they face.

Nonetheless, there is one public policy implication that seems reasonable to draw at this stage: outside drug discovery and at least in the semiconductor industry, there is a need to address the underinvestment problem, particularly for basic research. The nature and scope of such interventions are beyond the purview of this thesis, and much work is needed to identify which interventions (if any) are appropriate.

Another important contribution of this dissertation is that it documents several robust empirical regularities. Chapter 3 shows that, by almost any measure, basic research is much more concentrated than is innovation in the semiconductor industry, while this is not the case in the pharmaceutical industry. Chapter 4 shows that given two scientists who publish the same number of articles, the one who publishes a larger fraction of them in basic scientific journals produces fewer patents, unless she is at a pharmaceutical firm (in which case a strong positive effect exists if she publishes in basic chemistry journals).

Regardless of whether one agrees with my interpretations, these empirical regularities exist and must be accounted for. Why is basic research so much more concentrated in the semiconductor industry than in pharmaceuticals? What accounts for the differences between the two industries? In each industry, why are some firms investing so much in basic research and others so little? What accounts for the patterns of publishing and patenting by industrial researchers?

This dissertation also makes several methodological contributions. Chapter 2 presents a novel application of the Ellison-Glaeser Index for measuring relative concentration. The E-G Index allows us to measure the degree of “surprise” when comparing two variables (in this case, basic research and innovation). The simple fact that basic research is concentrated in the semiconductor industry is uninteresting, but we

learn something new by coupling this fact with the realization that innovation is widespread. The E-G Index provides a formal model for making such comparisons, controlling for several competing explanations.

Another methodological contribution is the development of several new bibliometric indices. In Chapter 2, I introduce the variables **HiAcad**, **HiSCI**, and **JCRBas**, which, respectively, identify journals that are highly academic, highly cited, and oriented towards basic research. These variables may be useful in other studies, particularly for understanding the kinds of research being performed by different organizations. Each of these variables captures a different facet of scientific research, as evidenced by the low correlation *across* measures (see Appendix 3-B). While several issues are associated with the use of bibliometric measures (Martin and Irvine, 1983; Collins and Wyatt, 1988), they can be reduced by combining these variables with other qualitative and quantitative measures, and by seeking empirical results that are robust to a variety of measures.

A methodological theme that runs through all three essays is the conscious attempt to combine data on patents and publications. While there have been many studies on patents, and a huge stream of literature exists on publications, there have been relatively few studies that combine both data sources. This is unfortunate, because such data (although imperfect) give us a glimpse into the R&D activities within firms, for which it is maddeningly difficult to obtain consistent and comparable R&D data. Patents and publications can inform our analysis as long as we do not rely on them exclusively, but rather supplement them with qualitative evidence or other data. I believe this dissertation breaks new ground in the extent to which it combines such data alongside rich qualitative analysis, particularly for the case study on copper interconnects. A related contribution is the development of a technique for matching names of individuals in the U.S. Patent database to those in the Science Citation Index (SCI). As discussed in Chapter 4, deficiencies in both databases makes this a difficult challenge. The method employed partly overcomes some of these limitations, and may have other applications.



A final contribution of this dissertation is that it raises new questions to be answered. Why are some firms more connected than others? How do the different types of absorptive capacity relate to firm capabilities and performance? Do the strong links between basic chemistry and patents exist anywhere outside drug discovery, or for any other scientific discipline? I hope these questions and others will lead to interesting future research, so that we gain a better understanding of how to manage technological innovation.



## **Chapter 2:**

# **The Many Faces of Absorptive Capacity: Spillovers of Copper Interconnect Technology for Semiconductor Chips**

In this chapter, I unpack the mechanisms for acquiring absorptive capacity and explore when each mechanism is important relative to the others. There are many ways for a firm to build absorptive capacity, which depends on internal R&D and the firm's connectedness to external sources of technical knowledge. A firm's investments in R&D versus the alternative mechanisms are closely tied to the kinds of knowledge to be acquired and its relationships with other organizations. I illustrate the implications of this framework with a case study on copper interconnect technology for semiconductors.

## **2.1 Introduction**

Knowledge spillovers are important to the productivity of firms (Jaffe, 1986; Mansfield, 1991) and to economic growth (Griliches, 1992; Romer, 1990). Cohen and Levinthal (1990) proposed a firm must make internal investments — particularly in R&D — to improve its ability to absorb knowledge spillovers. This notion of “absorptive capacity” is an important theoretical contribution that has gained considerable influence (see Section 2.2). It raises many interesting questions that remain unanswered. When is internal R&D important for absorptive capacity, and when are alternative mechanisms more effective? Are there different kinds of absorptive capacity?

In this chapter, I explore the mechanisms used by firms to build absorptive capacity, and when each alternative is important relative to the others. A firm's absorptive capacity primarily depends upon its internal R&D and the firm's connectedness to external sources of relevant technical knowledge. The firm can enhance its connectedness by: (1) performing R&D; (2) funding research at universities, maintaining relationships with faculty, and hiring graduate students; (3) forming alliances

with companies that possess relevant technology; and (4) obtaining membership in research consortia.

The link between connectedness and absorptive capacity was noted by Cohen and Levinthal (1990) and explored by other authors (e.g. Powell, *et al.* 1996; Cockburn and Henderson, 1998). This chapter clarifies the relationship between absorptive capacity, R&D and connectedness, and explores the following implications. First, there are many ways to build absorptive capacity, with the alternatives being at least as important as internal R&D. Second, *different types* of absorptive capacity arise depending on whether firms invest in internal R&D or the alternatives. Third, a science-oriented research environment, as advocated by Gambardella (1992), may be useful but not necessary for absorption. I discuss these implications in Section 2.2.

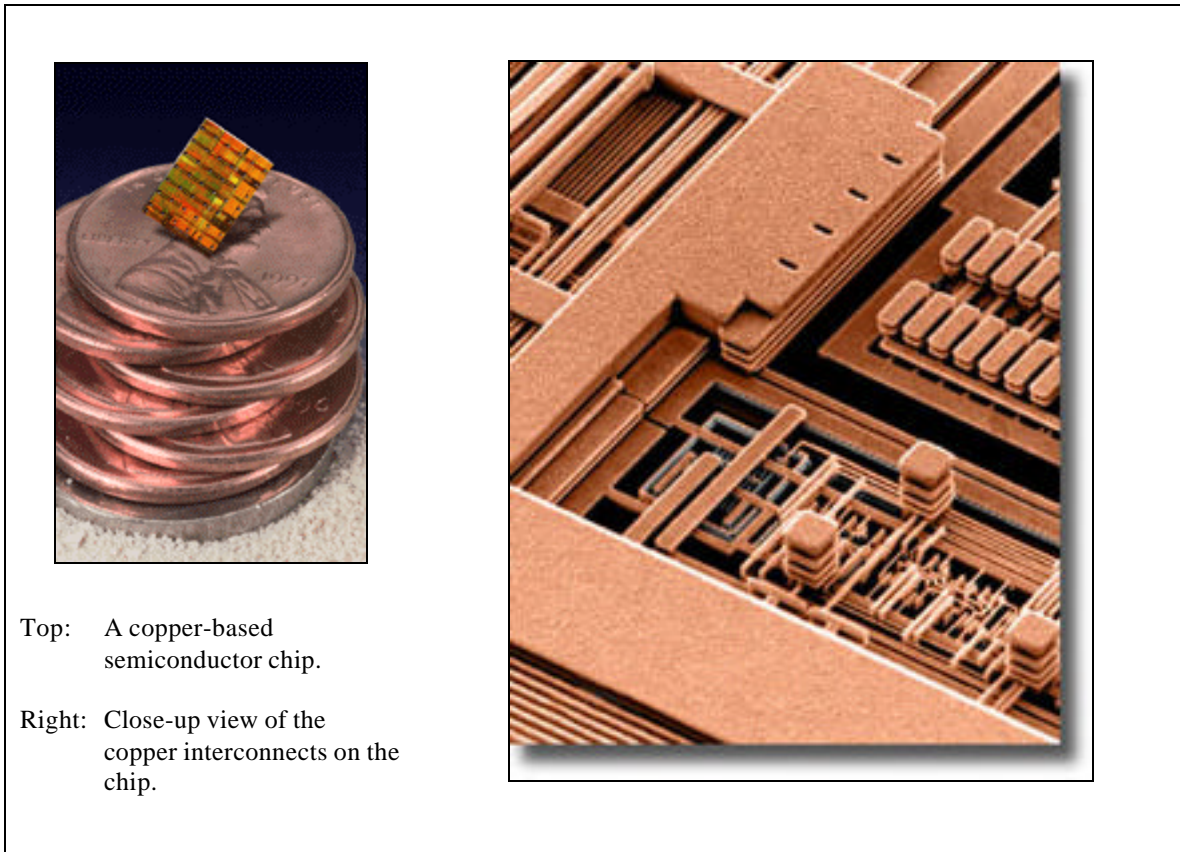
The importance of connectedness to absorptive capacity is usefully illustrated by a case study on copper interconnect technology.<sup>6</sup> In the context of semiconductor integrated circuits, *interconnects* refer to the conductors through which electricity flows between various circuit elements (see Figure 2-1). The use of copper instead of aluminum for making on-chip interconnects is a recent innovation of great importance. Certain features of copper technology make it very attractive for this study (see Section 2.3.1). The most important is that its adoption relies upon a new and clearly defined set of skills. This makes it feasible to identify the prior relevant R&D performed by each firm and to track the spillovers of ideas across organizations.

Copper interconnect technology was developed by IBM over a 30-year period, but has been adopted with great rapidity by other companies. The IBM story is itself of great interest and is reported elsewhere.<sup>7</sup> The focus in this chapter is on how other firms absorbed spillovers from IBM and other external sources of knowledge.

---

<sup>6</sup> I use “copper interconnect technology” and “copper technology” interchangeably.

**Figure 2-1: Semiconductor Chip with Copper Interconnects.**



Source: IBM Corporation, Research Division, Almaden Research Center. Reproduced with permission.

The semiconductor industry is one in which prior relevant experience should be paramount because it depends upon complex, embedded knowledge. Surprisingly, several firms were successful at capturing spillovers from IBM and universities even though they did not perform much of the early research. Furthermore, several firms were quicker to ship products based on copper technology than other firms that had made greater investments in relevant R&D. Both patterns are explained by the connectedness of the faster adopters to universities, Sematech, and to other firms that had worked on copper technology. The better-connected firms gained useful information and an advantage in recruiting people with copper-related expertise from those sources.

---

<sup>7</sup> Published accounts include an IBM *Think* magazine article (1998), an article in the *IBM Research*

This chapter makes several contributions to the literature on innovation. Firstly, it presents a framework that clarifies the relationship between internal research, connectedness and absorptive capacity. There are many ways for building absorptive capacity. Therefore, knowledge spillovers are difficult to contain, just as Nelson (1959) and Arrow (1962) had recognized.

Secondly, this chapter presents a novel methodology for identifying prior relevant R&D performed by each firm: it exploits the dependence of copper technology on new technical skills identify prior experience that should have helped firms to absorb external knowledge.

Thirdly, this chapter integrates the quantitative analysis of patents and publications with detailed qualitative fieldwork to overcome the limitations of each approach if used on its own.<sup>8</sup>

The remainder of this chapter is organized as follows. The next section critically analyzes the literature on knowledge spillovers. Section 2.3 presents the methodology and research setting. Section 2.4 describes the development of copper technology by IBM and the surprising speed with which other firms adopted it (including those that had invested little in prior R&D). It then shows that the connectedness of firms to external technical knowledge strongly affected the speed with which they adopted copper technology. Section 2.5 discusses alternative factors that influenced adoption and how they affect the results. It also discusses why IBM pursued copper R&D and published research on the technology despite the spillovers. Section 2.6 draws conclusions.

---

<sup>8</sup> *Magazine* (1997), and an *EETimes* special feature (1998). These are listed in the bibliography. For other studies on spillovers that combine qualitative and quantitative approaches, see Verspagen (1999) and Kim (1997). Kim (1997) relates how Samsung built absorptive capacity by being closely connected with Micron Technologies and by setting up an R&D outpost in Silicon Valley to hire U.S. engineers, including Korean-Americans with Ph.D. degrees from top U.S. universities.

## 2.2 The Determinants of Absorptive Capacity

In two seminal articles, Nelson (1959) and Arrow (1962) characterized knowledge as having the features of a durable public good. The knowledge produced through the R&D of an innovator is easily “borrowed” by another party to increase the latter’s productivity, without compensating the former. The innovator cannot appropriate the marginal value of the knowledge it produces and therefore under-invests in its production, relative to the social optimum.<sup>9</sup> Griliches (1992) makes an important distinction between ideas that are expropriated, and inputs that are purchased below their actual costs. Borrowed ideas are “true” spillovers and a source of productivity growth, while under-priced inputs constitute a measurement problem.

Departing from the view that knowledge spillovers are easily acquired, Cohen & Levinthal (1989, 1990) proposed that knowledge spillovers come at a cost to the recipient. Firms must invest resources in order to absorb knowledge spillovers. Cohen and Levinthal note that this investment may take many forms, and that many mechanisms exist for building absorptive capacity (including connectedness). However, the form of investment that they primarily emphasize is *prior related R&D*. According to Cohen and Levinthal (1990, pp. 135) this relationship between R&D and absorptive capacity arises because knowledge is (1) hard to codify or tacit (Polanyi, 1958) and (2) embedded in the routines of the organization (Nelson and Winter, 1992). From this perspective, R&D has two “faces”: it increases a firm’s productivity and its absorptive capacity.

This theory is broadly consistent with empirical data. Jaffe (1986, pp. 993) found that the interaction between a firm’s R&D expenditure and spillovers is strongly correlated with the firm’s performance. Similar evidence is offered by Gambardella (1992), Henderson and Cockburn (1996), Arora and Gambardella (1992), Lane and Lubatkin (1998), and Zucker and Darby (1995). However, these studies are hindered by the difficulty of separating the two faces of R&D. It remains unclear whether R&D made

---

<sup>9</sup> Nevertheless, Spence (1984) argues that the negative impact of spillovers on appropriability is partially offset if those spillovers reduce *ex-post* costs for the industry as a whole.

some firms more successful because they were better at capturing spillovers or because their R&D was more productive.<sup>10</sup>

Cohen and Levinthal made an important theoretical contribution by uncovering the relationship between R&D and absorptive capacity. This raises many interesting questions that remain unanswered. When is R&D important for building absorptive capacity, and when are the other mechanisms important? Do different kinds of absorptive capacity exist? Can a firm increase its absorptive capacity by hiring people whose heads contain valuable tacit knowledge?

Adopting a social network perspective may help resolve some of these questions. This shifts the focus of attention to the relationships surrounding the firm (Wasserman and Faust, p. 4). From this perspective, the crucial factor is the firm's *connectedness* to external sources of public and private knowledge (Cockburn and Henderson 1998; Powell, Koput, and Smith-Doerr 1996).

The emphasis on connectedness may seem subtle, but it has important implications. Chiefly, it disentangles the role of R&D and connectedness as distinct, but related, phenomena. Performing R&D may increase a firm's ability to recognize technological opportunities, and to attract and retain employees connected to the external scientific community (Cockburn and Henderson, 1998; Pavitt, 1991). However, a firm that does not perform R&D *is not excluded* from building absorptive capacity if alternatives are feasible. Such alternatives include funding research at universities, co-authoring with academics, joining R&D consortia, and forming alliances with other companies with access to technology. These activities permit a firm to remain in close connection with important external sources of technical knowledge, and provide it with opportunities to hire individuals who possess valuable tacit knowledge.

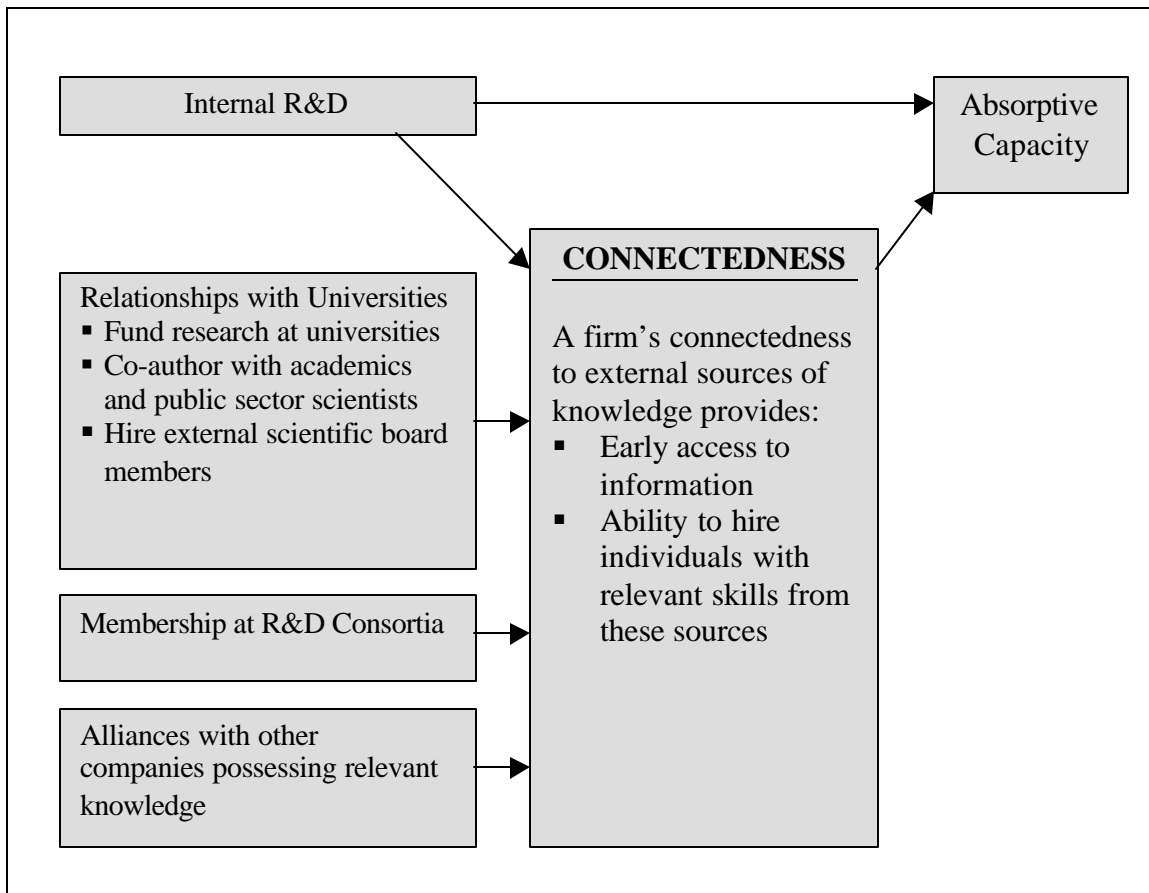
---

<sup>10</sup> Also, much empirical work has concentrated on the pharmaceutical and biotechnology industries, and it is uncertain how well the results apply in other areas.



I propose that these alternative ways for building absorptive capacity are at least as effective as internal R&D. Along with R&D, they constitute the “many faces” of absorptive capacity. This framework for understanding absorptive capacity is shown in Figure 2-2.

**Figure 2-2: Absorptive Capacity as a Function of Connectedness**



A second implication of connectedness is that there may be different kinds of absorptive capacity, depending on whether a firm obtains it through R&D or alternative means.<sup>11</sup> Internal R&D may be useful for absorbing *disciplinary* scientific knowledge. However, a firm without deep internal R&D could leverage its connections with universities and other companies to hire individuals who possess *domain-specific*

knowledge. In section 2.5.3, I elaborate on how IBM used internal R&D to absorb disciplinary spillovers, while other companies leveraged their relationships to acquire domain-specific knowledge from universities and other firms. Over time, as an increasing amount of relevant knowledge became accessible and codified, the dominant mode for building absorptive capacity shifted from internal R&D to relationships with universities, and eventually to strategic alliances with competitors and equipment suppliers that already possessed knowledge on copper interconnect technology.

A third implication of connectedness is that an “open” scientific environment, while useful, is not essential. Gambardella (1992) noted that successful pharmaceutical firms are like academic departments, offering their scientists autonomy to choose research projects and publish their work. This openness is viewed as a way to gain access to the inner circle of scientific communities. But a science-oriented research environment could also be a means of rewarding researchers in lieu of better compensation (Stern, 1999). To increase appropriability, a firm could decide to implement a *less open* scientific environment and reward its researchers through better salaries and promotions. Yet, it could *still remain connected* to the scientific community by funding research at universities and paying top researchers to join its scientific advisory board. In section 2.4, I describe how IBM kept up with external research while maintaining the secrecy of its own copper R&D project.

A re-examination of the empirical literature highlights the importance of connectedness. According to Cockburn and Henderson (1998), pharmaceutical firms that co-authored research articles with public-sector scientists had better performance. Zucker and Darby (1995) showed that biotechnology firms that collaborated with star scientists at universities (or employed them) were faster adopters. Liebeskind *et al.* (1996) reported that scientists at two biotechnology firms improved the integration of external knowledge by collaborating with outside researchers. In the remainder of this

---

<sup>11</sup> Hansen (1999) explores a related theme, that the nature of relationships required for knowledge transfer depends on whether knowledge is tacit or explicit.

chapter, I present a case study of copper interconnect technology to illustrate how the absorptive capacity of various firms depended upon their prior R&D investments and their connectedness to external sources of technical knowledge.

## 2.3 Methodology

I conducted an in-depth case study to trace knowledge spillovers of an important semiconductor technology: copper interconnects. The case study approach was chosen over a large-scale research design because it provides an important advantage: the ability to *trace specific ideas* that were “borrowed” by other firms. Spillovers are by nature difficult to observe, so large-scale studies often have to *infer* that spillovers actually occurred.<sup>12</sup> By tracing the flow of ideas, I offer an “inside-the-black-box” view of spillovers instead of assuming that they occurred.

This section is organized as follows: Section 2.3.1 describes the choice of this setting; Section 2.3.2 describes the quantitative and qualitative methodology used for the case study; and Section 2.3.3 introduces copper technology and the skills upon which it relies.

### 2.3.1 Research Setting

The semiconductor industry is a major pillar of other high-technology industries and shipped \$144 billion worth of products in 1999.<sup>13</sup> Spillovers are pervasive in this industry (Tilton, 1971; Mowery, 1983; Appleyard, 1996).<sup>14</sup>

---

<sup>12</sup> Some methods include: (1) citation analysis without corroborating fieldwork; (2) counting the number of articles co-authored with outside researchers; (3) interacting a firm’s R&D with the sum of all other R&D in a regression; and (4) assuming technological closeness implies greater spillovers.

<sup>13</sup> Source: Semiconductor Industry Association.

<sup>14</sup> According to Mowery (1983), these spillovers occur among industrial laboratories, universities, and the military. Appleyard found that public sources of knowledge are important in the semiconductor industry.

The semiconductor industry is an excellent setting for studying absorptive capacity. Producing semiconductor chips requires highly technical knowledge covering a broad range of disciplines, including physics, chemistry, and materials science. Much of this knowledge is tacit and deeply embedded in organizational processes. Designing and manufacturing a semiconductor chip involves a great deal of judgement that is difficult to codify. The manufacturing process itself is horrendously complex and requires almost perfect coordination among hundreds of intricate and interrelated steps, each subject to variability from human operators and minor details in the manner and sequence in which it is performed. In short, the semiconductor industry depends upon complex, embedded knowledge. These are the conditions under which we should expect prior relevant R&D to enhance absorptive capacity (Cohen and Levinthal, 1990).

One of the most significant recent innovations in the semiconductor industry is the development of copper interconnects to replace aluminum. IBM was largely responsible for creating this technology, devoting three decades of research and millions of dollars. In September 1997, IBM announced the availability of copper technology to great fanfare (Zuckerman, 1997).<sup>15</sup>

Copper technology will have a large economic impact. IBM's stock price jumped 5% on the day of the announcement and an additional 6% when it went into production a year later.<sup>16</sup> As the semiconductor industry moves to smaller devices, the use of copper will become pervasive. By some estimates, this will occur as early as 2002.<sup>17</sup>

Several features of copper interconnect technology make it suitable for this study. The most important is that it *depends upon a different set of skills and competencies* than do traditional aluminum interconnects (see Section 2.3.3). These skills are distinct and

---

<sup>15</sup> This news made it to the front page of *The New York Times* and other newspapers. By comparison, the invention of the transistor was announced on page 46 of that newspaper (Riordan and Hoddeson, p. 8).

<sup>16</sup> A 5% increase in IBM's stock price in 1997 corresponded to an increase in market capitalization of around \$5 billion (source: analysis of CRSP data).

<sup>17</sup> The "SEMI Copper Critical Survey 1999" reports that two-thirds of semiconductor companies will have copper-based chip in full production volume by 2001-2002.

fairly well defined, making it feasible to account for the “relevant prior experience” of each firm. Had copper technology been simply an extension of aluminum, tracking the vast amounts of prior research would have been a formidable task.<sup>18</sup> Another useful feature of copper interconnect technology is that the spillovers are recent. Thus, the trail of evidence was still fresh when I began this research project at the time of IBM’s announcement.<sup>19</sup> In addition, the spillovers occurred from relatively few sources, making them possible to track.

### **2.3.2 Research Method and Data**

This case study combines both qualitative and quantitative approaches. This helps to overcome the limitation of each (Yin, 1994).

#### **Quantitative Analysis**

The quantitative analysis is based on a dataset of patents and publications relevant to copper interconnect technology (see Appendix 2-A). Data on publications were obtained from the Science Citation Index (SCI) and data on patents from the U.S. Patent Office. The dataset contains 413 relevant articles (1985-1997) and 216 U.S. Patents (1976-1999). The definition of a “relevant” set is necessary because copper has many other uses within and outside the semiconductor industry. Relevant patents and publications were chosen based upon the relevant skills identified in Section 2.3.3.

I approximated each firm’s level of prior relevant R&D using the number of patents and publications it produced. This data is subject to bias, as not all research results are published or patented (some firms may choose to keep them secret). Also, papers may not meet the standards for publication and patent applications may be rejected. Another issue is that the coverage of the Science Citation Index, while excellent, is incomplete: it

---

<sup>18</sup> In addition, the citation analysis would have been much more difficult because of the massive number of publications and patents on aluminum interconnects throughout its 30-year history.

<sup>19</sup> For example, I was able to attend an IBM technical presentation at which that firm finally lifted the shroud of secrecy covering its development efforts.

covers all major scientific journals, but excludes several related engineering journals and neglects conferences. However, the SCI is the best available source, because other bibliographical databases contain only the address of the first author.

I traced knowledge flows using patent-to-patent and patent-to-science citations. The dataset contains all cited patents awarded after 1960, as well as all the scientific publications cited by the copper patents of four leading companies.

Citation analysis has long been used to measure knowledge spillovers across organizations (e.g., Jaffe, Trajtenberg, and Henderson, 1993; Martin and Irvin, 1983; Narin and Rozek, 1988; Verspagen, 1999). Patent-to-patent citations indicate spillovers of technological knowledge, while patent-to-science citations indicate spillovers from scientific fields (Narin, *et al.*, 1997; Verspagen, 1999).<sup>20</sup> Unfortunately, not all the citations in a patent are placed there by the inventor(s). An unspecified number are introduced by patent examiners, who have a duty to check the originality of the invention and its limits (Collins and Wyatt, 1988, p. 66). Thus, one cannot determine conclusively from patent citations alone whether the initial inventors actually relied upon the knowledge cited.<sup>21</sup> An additional problem with patent-to-patent citations is that few universities obtained patents on copper interconnects even after the Bayh-DohI Act (1980) made it legal for them to do so. Thus, patent-to-patent citations are not a good measure of spillovers of copper interconnect technology from academia to firms.

In order to overcome these limitations and to provide additional insights, I performed extensive qualitative fieldwork.

### **Qualitative Analysis**

The qualitative analysis includes semi-structured interviews with about two dozen scientists, R&D managers, and academics *involved directly* in developing copper

---

<sup>20</sup> Patent-to-patent citations indicate the flow of technology because the cited patent must contain *useful* knowledge (a precondition for it to have been granted).

technology.<sup>22</sup> Each interview lasted 45-60 minutes and included in-depth information about (1) the internal development efforts of each firm; (2) technological options explored; (3) sources of internal and external knowledge; (4) appropriability; and (5) adoption of the technology. I visited several of the companies and attended technical conferences to gain a better understanding of the technology and access to industry sources. I also analyzed more than 200 related articles from technical journals, newspapers, and trade journals.

### **2.3.3 Copper Interconnect Technology and the Skills Upon Which it Depends<sup>23</sup>**

Copper is the preferred material for conducting electricity because of its low resistance. It is ubiquitous in electrical wiring and printed circuit boards. But for the past thirty years, aluminum has been used instead of copper for the interconnections within semiconductor integrated circuits. Over time, aluminum interconnects have evolved so that today's interconnects are actually made from aluminum alloys, usually Al-Cu. The process involves depositing a blanket layer of the metal onto a silicon wafer, after which















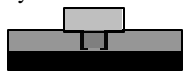

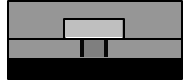
---

<sup>21</sup> Further issues regarding the use of patent citations are discussed in Narin, et al. 1997.

<sup>22</sup> Prior to 1990, there were 102 unique researchers who published articles on copper interconnects; between 1990 and 1999, the number was 978. Most of the interviewees were involved early on, and played a key role in the development of copper interconnect technology.

<sup>23</sup> Liu (1996) provides an excellent introduction to interconnect technology. For copper interconnects, see Park (1998), Gutmann (1999), and Liu *et al.* (1999). The material in this sub-section draws upon these sources and other technical publications.

Figure 2-3: Copper Damascene versus Etch Process

Aluminum Interconnects with Tungsten Plugs	Copper Damascene	Copper Dual Damascene (See Note 1)
Step A1: Deposit interlayer dielectric (ILD) and etch location of tungsten plugs, or “vias” 	Step B1: Deposit interlayer dielectric (ILD) and etch location of copper vias 	Step C1: Deposit ILD and etch away the location of interconnects 
Step A2: Deposit barrier layer and Tungsten 	Step B2: Deposit barrier and seed layers 	Step C2: Use lithography to define via patterns and etch away vias 
Step A3: Remove unwanted Tungsten to form “plug” 	Step B3: Electroplate copper and polish top surface 	Step C3: Remove photoresist, deposit seed and barrier layers 
Step A4: Deposit Aluminum (or Al-Cu) 	Step B4: Deposit ILD and etch location of interconnects 	Step C4: Deposit copper and polish 
Step A5: Use lithography to define the areas of Aluminum interconnects 	Step B5: Deposit barrier layer and seed layer 	
Step A6: Etch away unwanted Aluminum using RIE 	Step B6: Electroplate copper and polish top surface 	
Step A7: Deposit Interlayer Dielectric 		

Note 1: There are three main variants of dual damascene. For further details, see Liu *et al.*, (1999), Park (1998), and Gutmann (1999).

Note 2: These steps are repeated for each layer of metallization.

Substrate: ■	Dielectric: □	Copper: ■	Tungsten: ■	Al-Cu: □	Photoresist: ■	Barrier & seed layer	Barrier Layer
--------------	---------------	-----------	-------------	----------	----------------	----------------------	---------------



the desired pattern of interconnections is defined using photolithography (see Figure 2-3, steps A4-A5). This leaves the unwanted portions unprotected. The surface is then placed inside a chamber containing a reactive gas (plasma), which “eats away” the unwanted portions, leaving the desired interconnects (steps A5-A6). An insulating layer known as an interlevel dielectric (ILD) is then deposited (step A7). These steps are repeated to form multiple levels of interconnects stacked atop each other.<sup>24</sup> Connections between the layers are made by etching holes (known as “vias”) into the interlayer dielectric and filling them up with Tungsten “plugs” (Figure 2-3, steps A1-A3).

Unfortunately, copper is very difficult to etch using plasma gases, so it is difficult to apply the traditional aluminum process. Worse, research by IBM in the 1960s showed that copper easily diffuses into silicon, thereby contaminating the very transistors it is meant to connect. To overcome these problems, all commercially available copper interconnect processes to date employ a method developed by IBM known as the *damascene* process.<sup>25</sup> This process cleverly eliminates the need to etch away the metal by reversing the sequence of steps used in the traditional process (see Figure 2-3, steps B4-B6 versus A4-A7). Specifically, the dielectric is deposited first, rather than the metal. The desired interconnect pattern is then etched into the dielectric (step B1). Next, a thin barrier layer is deposited to protect the silicon from being contaminated by the copper (step B2). This is followed by a seed layer of copper, which acts as an “electrode” for an electroplating process that is used to deposit the actual copper layer (step B3). The surface is then polished flat. In a single damascene process, these steps are done once for the interconnect and once for the via. In the dual damascene process, both are combined (steps C1-C4).

IBM introduced the damascene process in the early 1980s.<sup>26</sup> Aluminum interconnects were used in this initial attempt. Formidable technical obstacles had to be

---

<sup>24</sup> Today’s chips generally contain four to six levels of metal interconnects, depending on the application.

<sup>25</sup> The Damascene process is named after an ancient swordmaking technique used in Damascus for combining two metals.

<sup>26</sup> IBM first introduced the damascene process in DRAM chips.

overcome before the damascene process could be implemented using copper instead of aluminum. First, unlike with aluminum, the propensity of copper to contaminate silicon requires that a *barrier layer* be placed between the two materials. The risk of contamination also has organizational implications: it requires careful handling on a production line so as not to contaminate the equipment being used and other wafers being processed. Organizational processes and the production flow must be modified to accommodate copper. Some companies consider the risk of copper contamination so great that they build entirely new fabrication plants for copper.<sup>27</sup>

The second, and perhaps most difficult, technical challenge is how to deposit a uniform layer of copper into the interconnect structures. These structures are deep and narrow, especially the vias that connect different layers.<sup>28</sup> For a long time, researchers struggled to identify a way to deposit copper into the vias without forming air bubbles and imperfections inside the copper. They explored four options: chemical vapor deposition (CVD), physical vapor deposition (PVD), electroless deposition, and electroplating.<sup>29</sup> All commercially available copper processes employ PVD to deposit the barrier and seed layers and use electroplating to deposit the interconnect itself. In contrast, the traditional aluminum process relies exclusively on PVD to deposit the aluminum (see Liu, 1996, p. 379). Although electroplating had been used on printed circuit board, it is an entirely new approach for on-chip interconnects.<sup>30</sup> In fact, the use of electroplating was highly counterintuitive at first, as it requires the delicate silicon

---

<sup>27</sup> For example, AMD built a new factory in Dresden, Germany to produce copper-based Athlon microprocessors. The identical part is being manufactured at the company's existing plant in Texas, but aluminum interconnects are being used instead; AMD is not planning to make these factories copper-capable. (source: Tom's Hardware Guide, <http://www.tomshardware.com>, June 2000).

<sup>28</sup> This problem does not arise with the traditional aluminum process because the interconnects and vias are laid down first and then blanketed by the dielectric. In the damascene process, the dielectric is laid down first, and then the vias and interconnect structures are etched into the dielectric.

<sup>29</sup> CVD involves suspending copper in a chemical vapor, which then produces a coating of copper on the semiconductor wafer. PVD involves bombarding the target surface with copper atoms that gradually form a layer. Electroplating involves immersing a surface into an electrolytic solution and running an electric current through two electrodes (one of which is the desired pattern on the surface), thereby accumulating copper on one electrode. Electroless deposition is similar to electroplating, but depends on a chemical reaction rather than requiring electrodes. See Liu (1996) for further details.

<sup>30</sup> Electroplating has also been used for multi-chip packaging, an area pioneered by AT&T and IBM.

wafers (which are manufactured in ultra-clean environments) to be dipped into “dirty” electroplating solutions.

A third technical obstacle arose because copper is a soft metal, making it difficult to polish each layer into a flat surface upon which to build the next layer. To do so, IBM developed a process known as Chemical-Mechanical-Planarization (CMP),<sup>31</sup> in which a rotating disk coated with slurry (a mix of chemicals) is used to polish the surface flat. The polishing action actually occurs at the molecular level, arising from chemical reactions between the surface and the slurry. This technique produces extremely flat surfaces. As with electroplating, CMP was a highly counterintuitive idea when first proposed. People were opposed to dunking their precious silicon wafers into a cocktail of powerful chemicals and then grinding them flat. Moreover, the process is extremely difficult to control, and even today remains somewhat of an art.<sup>32</sup>

Once the copper is deposited and polished flat, a final technical obstacle remains: unlike aluminum, which forms a natural protective coating, copper oxidizes when it is exposed to air, and so the copper interconnects require a *passivation layer* to protect them from corrosion.

These were difficult technical obstacles to overcome, which explains why aluminum has been used instead of copper throughout the history of the semiconductor industry. But these difficulties also point to the technical skills that would have helped adoption. They include prior R&D on: (1) copper deposition — CVD, PVD, electroless,

---

<sup>31</sup> CMP techniques were initially developed in the 1920’s for polishing glass. IBM adapted the technique for semiconductor wafers. For more details on CMP, see Liu, et al. (1999).

<sup>32</sup> The traditional aluminum process uses CMP for polishing the dielectric (ILD) and the tungsten plugs. However, the CMP process is much more complicated with copper, because it is a soft metal. The copper has to be polished down to the dielectric layer without damaging it, a difficult task because the copper is subject to erosion and dishing (Park, 1998, p. 15-17).

and electroplating; (2) copper damascene or dual damascene; (3) copper CMP; (4) barrier layers for copper; and (5) passivation layer for copper.<sup>33</sup>

The companies that developed these capabilities and adopted copper could expect an attractive reward in terms of circuit performance and manufacturing cost. First, the electrical resistance of copper is 40% lower than that of aluminum, which translates into faster chips and lower heat dissipation (ideal for high-performance and portable devices).<sup>34</sup> Second, the dual damascene process has fewer steps and is estimated to cost 20-30% less than the traditional aluminum process. And third, the electromigration properties of copper are better than those of aluminum.<sup>35</sup>

## 2.4 The Copper Puzzle

The pattern of R&D on copper interconnects and its adoption by various firms reveals an interesting puzzle (see Table 2-1). IBM pioneered much of the early research on copper interconnects and became the first company to ship copper-based products. However, two surprising facts emerge. First, it was only a very short time between IBM shipping its first product and other firms (Motorola, TSMC, UMC, VLSI and AMD) shipping their products. In fact, Motorola and Texas Instruments announced their own copper interconnect technologies just weeks after IBM's announcement. Within a year of IBM, four other companies were also shipping copper-based products.<sup>36</sup> These firms had

---

<sup>33</sup> While searching for patents and publications, I also included work on copper etching. In any case, the number of patents and publications on copper etching for interconnects is exceedingly low, and does not affect the results of the quantitative analysis.

<sup>34</sup> Electrical resistance interacts with capacitance to limit the switching frequency of a circuit. Consequently, a conductor with lower resistance enables faster switching to occur.

<sup>35</sup> Electromigration is the movement of atoms when an electrical current runs through a metal. After extended periods, electromigration causes physical distortions in the shape of an interconnect and adversely affects its electrical properties.

<sup>36</sup> In 1999, Motorola began shipping copper-based SRAMS and PowerPC chips (the PowerPC chips are used to power the Apple Macintosh G4). Apart from IBM and Motorola, the only other companies to ship copper-based products by 1999 were TSMC and UMC in Taiwan and VLSI Technology in USA. In 1999, AMD demonstrated copper-based Athlon microprocessors; it began shipping them in June 2000. These early adopters will be followed in 2000 by Lucent, Texas Instruments, Chartered Semiconductors, NEC, and Hitachi. Most other companies plan to adopt copper interconnect technology by 2001 or 2002.

done much less R&D than IBM. The second interesting fact is that several firms — including Motorola, AMD, UMC, and TSMC — were quick to ship their copper products relative to firms that had published a greater number of research articles on that topic, (e.g., AT&T, Hitachi, and NTT). Astonishingly, TSMC, UMC and VLSI began shipping copper-based products only two years after they began R&D.

**Table 2-1: Prior R&D Relevant to Copper Interconnects versus Year of First Shipment**

Organization	No. of Publications on copper interconnects in the Science Citation Index (1985-1997)	Start of Copper R&D	First Shipment	Years elapsed
IBM	40	1960s	Sep 1998	30+
Motorola	3	1990	Mid 1999	10
TSMC- Taiwan Semiconductors	0	Mid 1998	End 1999	2
UMC- United Microelectronics	0	Mid 1998	End 1999	2
VLSI Technology	0	1997	End 1999	2
AMD	1	1995	June 2000 <sup>†</sup>	5
Texas Instruments	2	Mid 1990s	2001*	6
AT&T (now Lucent)	7	1993	2001*	8
CSM -Chartered Semiconductors	0	July 1997	2001*	4
Hitachi	5	≈1986	End 2000*	14
NEC	1	Early 1990s	End 2000*	?
NTT	8	≈1990	2000 or later*	≥ 10
Intel	3	1988	2002*	14
<i>Sematech (consortium)</i>	2	1988/1993	NA	NA

Earlier Adoption ↑

Notes: Sorted by date of first shipment

\* Estimates from interviews and news reports.

<sup>†</sup> AMD demonstrated copper-based microprocessors at the end of 1999 and began shipments in June 2000.

The first observation suggests that other firms had absorbed knowledge spillovers from IBM (even though they had performed much less R&D than had IBM). The second observation suggests that several firms with little prior R&D used other means of developing absorptive capacity, so that they were at least as fast at absorbing spillovers as other firms that had done more R&D. These claims are substantiated using the following logic:

- I first provide evidence that firms depended on knowledge spillovers from IBM and other sources (Section 2.4.1). This rules out two alternative explanations: (1) that they did not rely on spillovers but developed copper interconnect technology by being more productive at R&D; and (2) that copper interconnect technology was an ‘obvious’ technological solution that other firms developed independently.
- Having established that firms depended upon spillovers, I then show that the prior R&D activity of each firm is insufficient to explain its absorptive capacity (Section 2.4.2).
- I then show the importance of a firm’s *connectedness* to absorptive capacity (Section 2.4.3). In the case of copper interconnects, better-connected firms obtained superior access to technical information and had greater opportunities to recruit relevant talent.

#### **2.4.1 Firms Depended On External Knowledge, Primarily from IBM**

It is tempting to believe that the other firms did not depend on external knowledge, and therefore did not perform much R&D because they had no need for absorptive capacity. Perhaps they were simply more productive at internal R&D than IBM? Or perhaps they independently invented copper interconnect technology? However, neither of these explanations is persuasive. Although other firms performed relatively little research, they depended heavily upon external knowledge from IBM, universities, and research consortia. IBM was the single most important source. The most compelling evidence of

IBM's importance is that all commercial copper processes to date *use the damascene process developed by IBM, and they deposit the copper using electroplating*.<sup>37</sup>

As noted above, damascene electroplating involves process steps that were not intuitive at the time of its invention, including reversing the sequence of steps from the traditional etch process and immersing the semiconductor wafers into “dirty” solutions (the electroplating bath and CMP slurry). This makes it highly unlikely that all the firms independently and simultaneously developed the same process. In retrospect, other companies could have pursued alternative metals and alloys.<sup>38</sup> But even had they chosen copper, they might have developed something other than the damascene process, and could certainly have deposited copper some other way (e.g., PVD, CVD, or electroless deposition).<sup>39</sup>

The knowledge dependence on IBM is consistent with the patent citation analysis. As shown in Table 2-2, the patents on copper interconnects by Motorola, TI, AMD, and other firms include a large number of citations to IBM patents. In aggregate, patents for copper interconnects make 265 citations to IBM patents, almost four times more than any other source.<sup>40</sup> The results remain robust if self-citations are eliminated, as shown in the last row of Table 2-2. The only firm that did not exhibit knowledge dependence on IBM in the patent-to-patent citations is AT&T, which had access to the bountiful resources of

---

<sup>37</sup> The ubiquity of this technique is apparent from industry interviews, news reports, and descriptions in the patents and publications of various companies. The first technical announcements of successful copper processes by IBM, Motorola, and Texas Instruments report using damascene electroplating (Proceedings of the IEEE IEDM Conference, 1997). Moreover, semiconductor companies do not manufacture their own equipment, but rely on a handful of equipment companies. To date, these suppliers only offer equipment for copper interconnects that employ the damascene process (see Wolfe 1998b).

<sup>38</sup> Murarka and Hymes (1995) present a comparison of copper with other metals, favoring copper. Each metal has advantages and disadvantages.

<sup>39</sup> Researchers at universities and firms continue today to explore PVD, CVD, and electroless deposition. These are expected to become important in the future because electroplated copper does not produce conformal surfaces (source: interviews). Intel and Applied Materials are exploring ways to apply traditional etch to copper interconnects (Koch *et al.* 1999).

<sup>40</sup> Interestingly, Motorola and AMD make as many citations of IBM patents as they do of their own patents. Texas Instruments cites IBM patents more than its own patents.

the Bell Laboratories (it is the only company that primarily cites itself).<sup>41</sup> Similar results are obtained if we consider only citations to patents directly related to copper interconnect technology (Table 2-3).

Another interesting result from Tables 2-2 and 2-3 is the strong knowledge dependence on Motorola, which received the second-highest number of citations. As is discussed below, Motorola relied heavily on knowledge spillovers from IBM, and then played a major role in disseminating this technology to other companies.

The knowledge dependence of other firms on IBM existed even though IBM relied heavily on secrecy to protect its technology.<sup>42,43</sup> IBM was so successful at keeping the project under wraps that many industry experts were surprised when the company made the official announcement in 1997.<sup>44</sup> Publications emerged from IBM on the general ideas relating to the damascene process and copper technology, but process-specific knowledge was kept carefully hidden.

---

<sup>41</sup> According to my interviews, Bell Laboratories has investigated almost every facet of semiconductor technology, including CVD, PVD, and electrodeposition (which it used for pioneering work on multi-chip modules).

<sup>42</sup> The other companies were not as secretive as IBM. At the other end of the spectrum stood AT&T's Bell Laboratories, which prided itself on the openness of its research and its resemblance to top-tier academic departments. Other companies fell between these extremes. (Source: interviews.)

<sup>43</sup> The information in this paragraph was obtained through field interviews.

<sup>44</sup> This is reflected in the 5% shock in IBM's stock price on the day of the announcement. My interviews reveal that industry experts knew about IBM's progress with copper but hadn't realized how close it was to putting copper into full-scale production. On the day of IBM's public announcement, *The New York Times* quoted an Intel spokesman: "If [IBM] can move it into production this early, that is certainly more aggressive than we and others had anticipated".



**Table 2-2: Number of Citations by Copper Interconnect Patents to All Other Patents**

Reference By	Reference To															Total
	Top Ten										Not Top 10					
	IBM	Moto- rola	TI	AT&T	Hita- chi	GE	Fujit- su	Blank	MCC*	Micro n	Sharp	AMD	Char- tered	Toshi- ba	Other	
IBM	103	16	29	10	18	17	16	10	8	6	2	4		10	187	436
Motorola	20	22		3			3	2		6			2		34	92
Texas Instr	16	2	5	3	4	2		2							8	42
Lucent/ AT&T				13											4	17
Hitachi	3					2									0	5
Fujitsu	16		2		2	2								2	5	29
MCC*	22		5	5		3		3	27		2				40	107
Sharp	9	4	5		3		3				9	2		7	31	73
AMD	19	4	3	2	4		2	4		2		21		4	21	86
Chartered Semi.		6			3		5			4			2	4	5	29
Toshiba	3	3	2		2									2	2	14
Other	54	20	19	14	7	15	10	17	3	18	0	5	4	5	147	338
<b>Total</b>	<b>265</b>	<b>77</b>	<b>70</b>	<b>50</b>	<b>43</b>	<b>41</b>	<b>39</b>	<b>38</b>	<b>38</b>	<b>36</b>	<b>13</b>	<b>32</b>	<b>8</b>	<b>34</b>	<b>484</b>	<b>1268</b>
<b>Total exc. Self-cites.</b>	<b>162</b>	<b>55</b>	<b>65</b>	<b>37</b>	<b>43</b>	<b>28</b>	<b>39</b>	<b>38</b>	<b>11</b>	<b>34</b>	<b>4</b>	<b>11</b>	<b>6</b>	<b>32</b>	<b>439</b>	<b>1004</b>

Notes:

- MCC\* = Microelectronics and Computer Technology Corp. of Austin, Texas, an industrial research consortium (<http://www.mcc.com>).
- Patents included are for 1976-1999, while citations to patents are for 1960-1999.

**Table 2-3: Number of Citations by Copper Interconnect Patents to Copper Patents**

Reference By	Reference To														Total
	Top Ten										Not Top 10				
	IBM	Moto- rola	Fujit- su	MCC*	Air Prod	Hita- chi	TI	Micro n	Sharp	AT&T	AMD	Char- tered	Toshi- ba	Other	
IBM	14	2	4	4		3	1						6	34	
Motorola	2	10	2	1	1			3					1	20	
Fujitsu	2					1							2	5	
Texas Instr	2	1			2	2	3		1	1			1	13	
Sharp	5	3			7		3		8				6	32	
Lucent/AT&T										5			0	5	
AMD	4	3	2			4			1	2	3		6	25	
Chartered Semi.		5	5			3		2				1	3	24	
Toshiba		2	1		1	1	1		1				1	8	
<i>Other</i>	<i>21</i>	<i>6</i>	<i>11</i>	<i>14</i>	<i>7</i>	<i>3</i>	<i>7</i>	<i>7</i>	<i>1</i>	<i>0</i>	<i>0</i>	<i>1</i>	<i>2</i>	<i>32</i>	
<b>Total</b>	<b>50</b>	<b>32</b>	<b>25</b>	<b>19</b>	<b>18</b>	<b>17</b>	<b>15</b>	<b>12</b>	<b>12</b>	<b>8</b>	<b>3</b>	<b>2</b>	<b>5</b>	<b>60</b>	
<b>Total excl self-cites</b>	<b>36</b>	<b>22</b>	<b>25</b>	<b>19</b>	<b>16</b>	<b>17</b>	<b>12</b>	<b>12</b>	<b>4</b>	<b>3</b>	<b>0</b>	<b>1</b>	<b>5</b>	<b>48</b>	

Notes:

- MCC\* = Microelectronics and Computer Technology Corp. of Austin, Texas, an industrial research consortium (<http://www.mcc.com>).
- Patents included are for 1976-1999, while citations to patents are for 1960-1999.

Copper research was deemed a top commercial priority at IBM. According to one IBM employee, the firm's researchers were "rewarded internally through other means" (financially and through promotions) rather than given permission to publish their more sensitive research.<sup>45</sup> For example, IBM's work on the chemical vapor deposition of copper (CVD) produced tangible results around 1983, but was not published till 1990. Some of IBM's research is *still not published* today, including the type of material it uses for the barrier layer and the chemical composition of its electroplating bath.

Only one part of the copper project was not done within IBM: the development of a copper-deposition tool, for which IBM, in 1995, signed a top-secret joint-development agreement with Novellus, a small but reputable equipment supplier. Under this agreement, Novellus was not permitted to reveal that it was working with IBM until months after IBM's public announcement, and IBM maintained a list of companies to which Novellus could not initially sell the tool. To mislead competitors, the joint-development project was located in Portland, Oregon — far away from IBM and close to Intel's development facilities.

IBM's secrecy makes the results in Tables 2-2 and 2-3 even more remarkable. By choosing secrecy, IBM withheld from patenting aggressively until the mid-1990s (see Table 2-6). Therefore, the data in Tables 2-2 and 2-3 *understate* the dependence of other firms on IBM, since there were fewer IBM patents to cite than had IBM patented its inventions earlier. A better measure of the dependence of other firms on IBM is the number of citations that are made by copper patents to the scientific literature. As Table 2-4 shows, IBM is the single largest source of publications cited in the copper interconnect patents of Motorola, AMD, and Applied Materials (the world's largest semiconductor equipment supplier).

---

<sup>45</sup> Stern (1999) showed that biologists on the job market experienced a compensating differential between the permission to publish research and monetary compensation.

**Table 2-4: Citations by U.S. Patents on Copper Interconnects to Scientific Articles.**

Patents By	IBM	Motorola	AMD	Applied Materials
<b>Number of References to Articles Published by:</b>	IBM (63)	IBM (12)	IBM (10)	IBM (9)
	Text Books (16)	RPI (4)	Trade Journals (3)	Applied Mat(5)
	AT&T (7)	U.C. Berkeley (4)	Microel Ctr N Carolina (3)	Oki Electric (3)
	Unknown (6)	Motorola (4)	Varian Associates (2)	Univ. de Paris-Sud (2)
	Toshiba (4)	Text Books (3)	Text Books (2)	Tech. U. Chemnitz Germany (2)
	Varian Associates (3)	Sematech (3)	Intel (2)	RPI (2)
	Mitsubishi (3)	SUNY Albany (2)	Georgia Inst Tech (2)	NTT (2)
	Univ Alberta (3)	NTT (1)	Northeastern Univ (1)	NEC (2)
	Oki Electric (3)	AT&T (1)	Airco Temescal Inc (1)	Hitachi (2)
	Hosei Univ, Tokyo (3)	CalTech (1)		Unknown (1)
	Harris Corp (3)	CNET France (1)		U. New Mexico(1)
	CNET France (3)	CNRS, France (1)		Sharp (1)
	Carleton Univ (3)	Intel (1)		Korea Inst. Sci & Tech (1)
	Philips (3)	Microel Ctr N Carolina (1)		CNET France (1)
	Fujitsu (2)	Air Prod&Chem (1)		AMD (1)
	Intel (2)	NEC (1)		
	Korea Inst. Sci & Tech (2)	Samsung (1)		
	Hughes (2)	Stanford Univ (1)		
	Motorola (2)	Tech. Univ. Dresden (1)		
	Sharp (2)	Tokyo Inst Tech (1)		
Siemens (2)	Toshiba (1)			
Spectrum CVD (2)	Taiwan Nat Chiao Tung U. (1)			
Univ Uppsala, Sweden (2)				
Others (6)				

Notes:

- Patents included are for 1976-1999.
- Citations are to *all* scientific articles, regardless of date.

Table 2-4 also shows that copper patents by these companies make a large number of citations to research published by universities and government laboratories. These laboratories and universities were crucial sources of knowledge spillovers for companies other than IBM (see Section 2.4.3). Unfortunately, their importance is not reflected in the patent-to-patent citations (see Tables 2-2 and 2-3). Few universities and government laboratories filed for patents on copper interconnects (see Figure 2-4), although they published a large number of articles on the subject (see Figure 2-5).<sup>46</sup>

#### **2.4.2 Prior R&D is Insufficient to Account for Absorptive Capacity**

I now turn to the prior relevant R&D of each firm, as indicated by the number of publications and patents it produced and by the number of years it worked on copper R&D.

Tables 2-5 and 2-6 show that other firms produced far fewer patents and publications on copper interconnects than did IBM. These tables also show that IBM is the only firm to have systematically investigated copper interconnects prior to 1989.<sup>47</sup> But due to IBM's secrecy, these data grossly underestimate the scale of IBM's R&D.

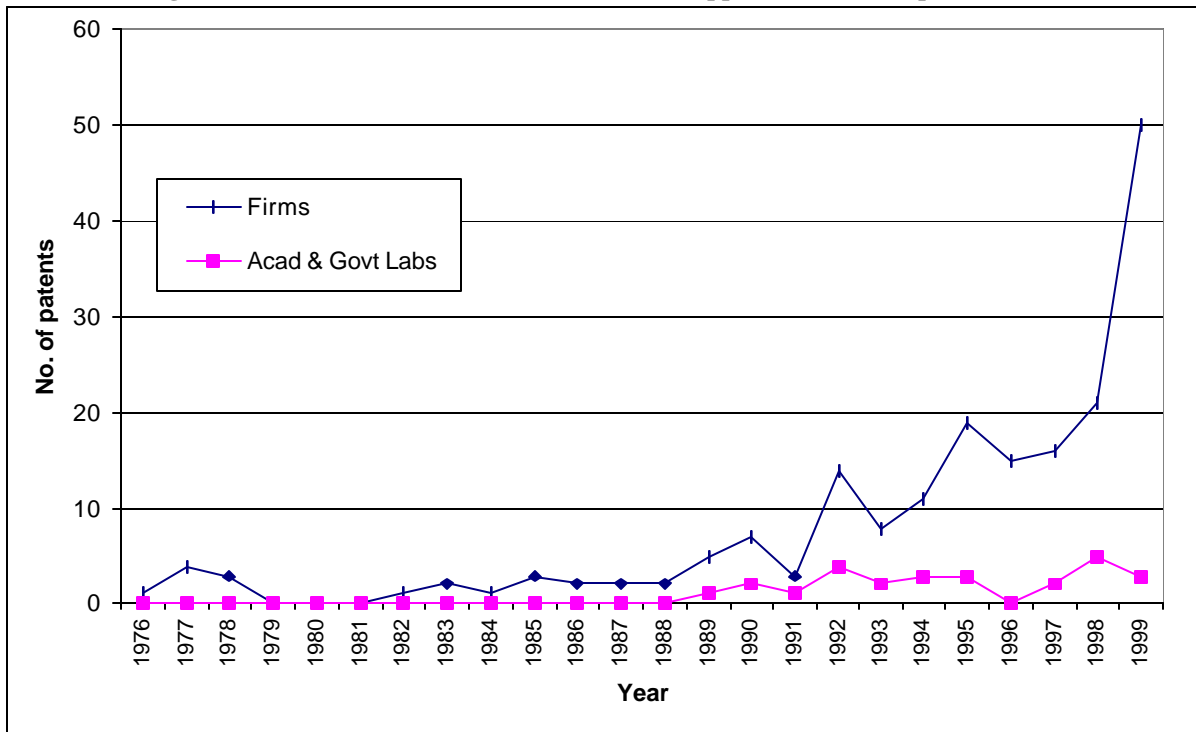
Published accounts and interviews with IBM researchers show that IBM began

---

<sup>46</sup> The Microelectronics and Computer Technology Corp (MCC), an industry R&D consortium in Austin, Texas, is the one exception: MCC is one of the most highly cited sources in Tables 2-2 and 2-3, for its work on copper electroplating for the packaging inside of which integrated circuits devices are mounted. This is similar to the work on multi-chip modules within IBM, which the firm drew upon for electroplating expertise.

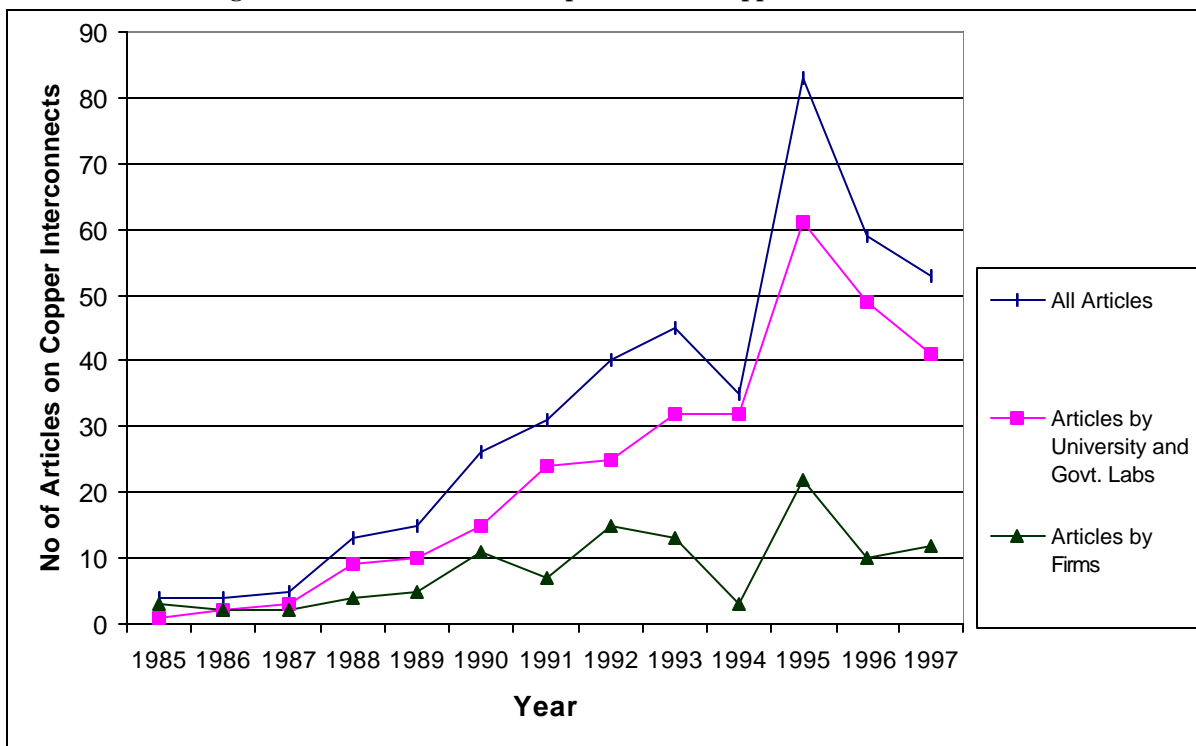
<sup>47</sup> Scattered efforts were made at other companies, including Boeing, General Electric, Motorola, and Intel. (Source: patent and publication data; interviews)

Figure 2-4: Number of U.S. Patents Related to Copper Interconnect per Year



Source: Analysis of Science Citation Index.

Figure 2-5: Number of Articles per Year on Copper Interconnects



Source: Analysis of Science Citation Index.

**Table 2-5: Number of Publications on Copper Interconnects per Year by Companies**

Company	1985	1986	1987	1988	1989	1990	1991	1992	1993	1994	1995	1996	1997	Total
IBM	3	1	2	1	3	7	1	6	3	1	8	3	1	40
NTT							2	1	1		2	1	1	8
Lucent/ AT&T							1	3	3					7
Hitachi								1	1		2	1		5
Toshiba									1			1	2	4
Intel Corp					1						1	1		3
Mitsubishi										1	2			3
Motorola									2		1			3
National Semicon.								1	1	1				3
Nippondenso							1	1	1					3
Oki Electric Ind.											2		1	3
DuPont				1		1	1							3
Applied Materials											2	1		3
<i>Other</i>	0	1	0	2	1	3	1	2	0	0	2	2	7	21
<b>Total</b>	<b>3</b>	<b>2</b>	<b>2</b>	<b>4</b>	<b>5</b>	<b>11</b>	<b>7</b>	<b>15</b>	<b>13</b>	<b>3</b>	<b>22</b>	<b>10</b>	<b>12</b>	<b>109</b>

Source: Analysis of Science Citation Index.

researching copper interconnects in the 1960s.<sup>48</sup> By the early 1980s, the company had invented the damascene process and pioneered CMP.<sup>49</sup> By the late 1980s, IBM had developed a barrier layer, and in 1989 IBM demonstrated a working RAM chip with copper interconnects laid down using chemical vapor deposition.

Around 1989, researchers at IBM discovered a way to electroplate copper onto semiconductor chips. For reasons not understood at the time, the copper thus deposited did not contain imperfections. Moreover, it had electrical properties far superior to that of IBM's CVD process. Almost overnight, IBM decided to switch to electroplated copper. IBM jealously guarded this secret for many years.

So, in the 1989 timeframe, IBM had all the pieces in place for a copper damascene

<sup>48</sup> See the IBM *Think* magazine article (1998) and *EETimes* special feature (1998).

<sup>49</sup> IBM also tried to etch copper, but technical difficulties convinced the firm to pursue the damascene route and abandon all etching efforts.

**Table 2-6: Number of Patents on Copper Interconnect per Year**

Company	1976	1977	1978	1979	1980	1981	1982	1983	1984	1985	1986	1987	1988	1989	1990	1991	1992	1993	1994	1995	1996	1997	1998	1999	Total
IBM	1						1	1	1		1	2		1	2		3	1	1	5	4	3	5	5	37
Sharp																				1		1	5	10	17
Motorola														1					1	4	1	1	2	6	16
AMD																				1	2	3	8		14
Texas Instr.													1	1	1		2		1	1		1	1	3	12
Lucent/ AT&T		2	1															1	2	2					8
Air Prod & Chem.																	3	1	1						5
Chartered Semicon.																						1	2	2	5
Fujitsu															1	1				2	1				5
Toshiba																	1					1		3	5
Boeing															2		2			1					5
Applied Materials																			1					3	4
LG Semicon.																					1	1	2		4
Hitachi											1			1	1	1									4
Intel																		1	1			1	1		4
Others	0	2	2	0	0	0	0	1	0	3	0	0	1	1	0	1	3	4	3	3	7	4	0	10	45
<b>Total</b>	<b>1</b>	<b>4</b>	<b>3</b>	<b>0</b>	<b>0</b>	<b>0</b>	<b>1</b>	<b>2</b>	<b>1</b>	<b>3</b>	<b>2</b>	<b>2</b>	<b>2</b>	<b>5</b>	<b>7</b>	<b>3</b>	<b>14</b>	<b>8</b>	<b>11</b>	<b>19</b>	<b>15</b>	<b>16</b>	<b>21</b>	<b>50</b>	<b>190</b>

Source: Analysis of US Patents



process. In 1991, the firm moved the project into development and, in 1993, announced a chip with four levels of copper.<sup>50</sup> In 1997, IBM began moving copper interconnects into production.

Other firms did much less exploratory R&D on copper interconnects than IBM, and only began to explore the technology seriously in the late 1980s and early 1990s. Patents and publications began appearing from other companies around 1989 (see Tables 2-5 and 2-6), and grew at a rapid rate (see Figures 2-4 and 2-5). Academic research also began to emerge at this time (see Section 2.4.3).

Several factors contributed to this expansion of research. There was a growing realization that the industry would not be able to cope with future needs using aluminum. In addition, IBM — although tight-lipped about the details — began to reveal that it was making progress with copper.<sup>51</sup> Momentum grew as technological breakthroughs began to appear from non-IBM researchers. Many of the researchers I interviewed described the emergence of a critical mass of people working on copper, and how this legitimized their own research and provided a justification for obtaining resources from their own organizations.

Intel's effort is noteworthy among the early firms to investigate copper. In 1989, Intel researchers published an article on copper interconnects using electroless deposition (Pai and Ting, 1989). One author was a former IBM employee; the other had recently completed a Ph.D. on VLSI interconnect technology at Berkeley.<sup>52</sup> Unlike electroplating, electroless deposition was not amenable to mass production, but eventually influenced researchers outside IBM to consider electroplating as a viable option.<sup>53</sup> However, at the

---

<sup>50</sup> This chip was not quite ready for the market. It used a special material known as Polyimide for the dielectric, which was expensive to manufacture in large quantities.

<sup>51</sup> Recall that IBM demonstrated a copper-based RAM chip in 1989 and published its work on CVD copper in 1990.

<sup>52</sup> Sources: Dissertation Abstracts Online; interviews with researchers. The origin of these two researchers suggests that Intel absorbed knowledge from IBM and Berkeley.

<sup>53</sup> By 1999, the Pai and Ting (1989) paper had been cited at least 91 times. (Source: WebOfScience.com)

time, electroplating received a lukewarm welcome because it seemed ludicrous to put silicon wafers into “dirty” electroplating solutions.

Despite its early lead, Intel did not follow up its research in a serious way.<sup>54</sup> Meanwhile, other U.S. companies — including Motorola, AMD, AT&T (Bell Labs) and Texas Instruments — began to explore copper interconnects. Motorola’s copper program began around 1990 and AT&T’s around 1993, but both went into full-scale development only around 1995. AMD did not begin its copper program until 1995, but ramped up quickly and moved into development by 1996. In Japan, NTT and Hitachi began copper R&D in the late 1980s.<sup>55</sup> However, interviewees indicate that most firms outside the United States were generally slower to explore copper technology and only began in the mid-1990s.<sup>56</sup>

It is revealing to compare the patterns of publications and patents (Tables 2-5 and 2-6) with adoption (Table 2-1).<sup>57</sup> Following Gambardella (1992), one might expect the firms that participated in “open science” (by publishing their research) to have produced more patents or adopted copper faster. Figure 2-6 shows the number of patents awarded to each firm versus the number of publications it produced. IBM is high on both counts, but several companies — including AMD, Motorola, TI, and Sharp — obtained a surprisingly large number of patents relative to the number of articles they published.<sup>58</sup> Among these firms, Motorola and AMD were subsequently early to market with the technology (see Table 2-1), while TI was at least as fast as NTT and AT&T, which had

---

<sup>54</sup> Or if it did, this was never publicly revealed. According to industry sources, Intel seriously began pursuing copper interconnect technology only around 1997.

<sup>55</sup> Hitachi began producing patents on copper interconnects from 1988 (e.g., see U.S. Patent No. 4842891). NTT published research on copper for multi-chip modules in 1991 and copper interconnects using CVD in 1992.

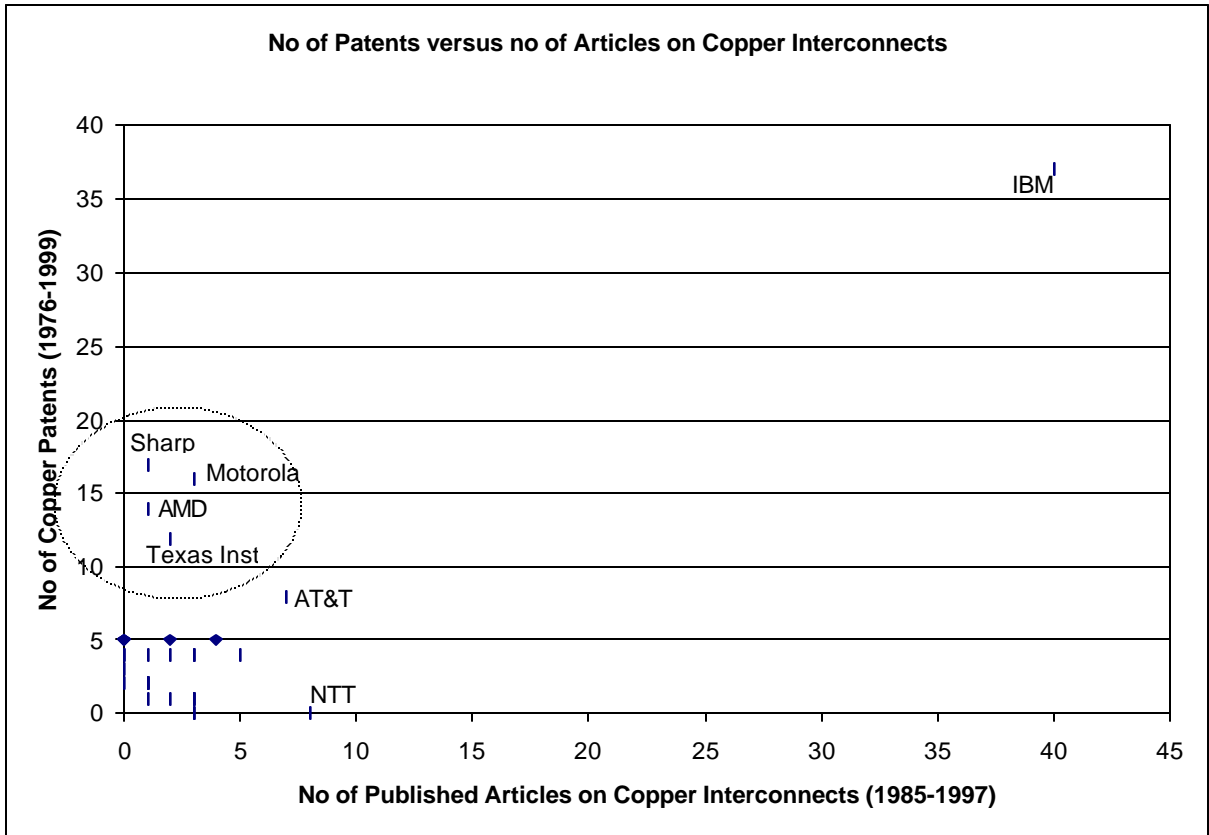
<sup>56</sup> After IBM’s announcement, a prominent Japanese researcher was quoted as saying that Japan was 3-5 years behind America in copper technology (see Lammers, 1998a).

<sup>57</sup> Ideally, one would run a regression of the hazard rate of adoption against patents and publications. However, the small sample of firms that have adopted this technology to date precludes this analysis.

<sup>58</sup> Excluding IBM, the raw correlation between copper patents and publications in Figure 2-6 is  $-0.09$ .

published more articles.<sup>59</sup> Thus, there appears to be a relationship between patents and adoption, but not between publications and adoption.

**Figure 2-6: Number of Copper Patents versus Number of Copper Publications**



Source: Analysis of Science Citation Index and U.S. Patents

An even more intriguing pattern is the *absence* from Figure 2-6 of the chip foundries (TSMC, UMC, VLSI, and Chartered).<sup>60</sup> These firms performed none of the initial R&D (some didn't even exist at the time), but they were at least as fast at adopting copper as other firms that *had* invested earlier in R&D. How did Motorola, AMD, and the foundries acquire the knowledge needed to adopt copper technology so quickly, despite the relatively low publication rates of these firms, and IBM's attempts to keep its

<sup>59</sup> Sharp received a large number of patents, but most of them were awarded in 1999 (see Table 2-6). I was unable to obtain its expected shipment date.

<sup>60</sup> Chip foundries are companies that manufacture semiconductor devices for other companies.

own knowledge secret? The next section proposes a solution: that these firms had other means of being connected to external sources of technical knowledge.

### **2.4.3 Absorptive Capacity Depends upon Connectedness**

The most important sources of external knowledge differ before and after 1997. Prior to IBM's announcement in 1997, the absorptive capacity depended strongly upon relationships with Sematech and several universities that followed in IBM's footsteps. IBM also contributed knowledge indirectly. After 1997, the absorptive capacity depended mainly on relationships with companies that already possessed copper interconnect technology and with equipment vendors. The remainder of this sub-section elaborates upon how and why this occurred.

#### **2.4.3.1 Spillovers before 1997**

Sematech and several universities played a key role in facilitating spillovers of copper interconnect technology between 1989 and 1997. Prior to 1989, academic research on the metallurgy and electrochemistry of copper existed, but there were no formal university programs directed specifically at copper interconnect technology for semiconductors. Table 2-7 shows that academic institutions and government laboratories published almost no research on copper interconnects prior to 1990.

#### **Sematech and Sematech-Funded Universities**

Around 1988, copper interconnects became a priority at Sematech, the consortium of leading American semiconductor companies.<sup>61,62</sup> Sematech began to fund a significant amount of university research by forming research centers, known as Sematech Centers of Excellence (SCOE). The SCOE project on interconnects was led by the Rensselaer

---

<sup>61</sup> Sematech was founded in 1986 to enhance the competitiveness of U.S. companies. In 1989, it had 14 members: IBM, AT&T, Motorola, Intel, AMD, Texas Instruments, DEC, Harris Corp, Hewlett-Packard, LSI Logic, Micron Technology, National Semiconductor, Rockwell, and NCR.

<sup>62</sup> Information in this paragraph and the next was obtained through interviews with researchers at universities, firms, and Sematech.

Polytechnic Institute (RPI) and also involved Cornell and SUNY.<sup>63</sup> Table 2-7 shows that publications began appearing from these universities around 1990. Universities in Japan, Korea, and Taiwan also began to research copper interconnects, but the Sematech-backed universities led by quite a margin in the number of publications (see Table 2-7). The work of Sematech-funded universities would eventually play a critical role in the diffusion of knowledge on copper interconnect technology.

**Table 2-7: Number of Publications on Copper Interconnects per year by the Top 10 Universities and Government Laboratories**

Company	1985	1986	1987	1988	1989	1990	1991	1992	1993	1994	1995	1996	1997	Total
Rensselaer Poly Inst*						5	1		3	4	5	1	1	20
Cornell*						2	2		2	2	1	1	6	16
Korea Adv Inst Sci & Tech								1			2	6	6	15
Univ New Mexico*								3	2	5	2	1		13
Lawrence Berkeley/ UC Berkeley							1	3	2		1	1	2	10
SUNY*						1		2		1	4	1		9
Univ-Illinois						1	1	1			2	3		8
Kyoto Univ, Japan						1			1		1	1	3	7
Nat Chiao Tung, Taiwan								1	1	2	1	1	1	7
Ecole Poly Lausanne, Switzerland					1		1	3		1			1	7
<i>Other</i>	1	1	0	3	4	3	4	6	9	8	25	15	12	91
<b>Total</b>	<b>1</b>	<b>1</b>	<b>0</b>	<b>3</b>	<b>5</b>	<b>13</b>	<b>10</b>	<b>20</b>	<b>20</b>	<b>23</b>	<b>44</b>	<b>31</b>	<b>32</b>	<b>203</b>

\* = university affiliated with the Sematech SCOE Program on Interconnects.

Source: Analysis of Science Citation Index.

Researchers at various universities and Sematech acknowledge that, during this period, they were “rediscovering” what IBM already knew. Much of the university research was in the same vein as earlier work at IBM, the important difference being that it was in the public domain. A handful of university researchers who attempted to etch copper quickly abandoned the process, and instead began to explore the damascene process.

<sup>63</sup> This program later expanded to include the University of Texas (Austin), Stanford University, and others. The Semiconductor Research Corporation (SRC) helped manage the SCOE program on

The basic idea of the damascene process had diffused out of IBM in the 1980s, although little was known outside IBM regarding implementation. In the early 1990s, much of the academic research was directed at copper deposition, primarily CVD. This was due in part to IBM's announcement around 1990 of its CVD work, although the firm had already moved on to electrodeposition by then (which provides further evidence that universities were, in fact, borrowing IBM's ideas).

RPI was a major contributor to the CVD work, and also worked jointly with SUNY Albany on PVD.<sup>64</sup> IBM, itself a member of Sematech and in close geographic proximity to RPI, kept track of and encouraged the research performed by universities. IBM even privately funded some research at RPI and other nearby universities.<sup>65</sup> However, there was no direct transfer of knowledge from IBM to the universities, apart from papers IBM published in journals and presented at conferences. IBM's perspective was that although it was way ahead in copper R&D, the firm had nothing to lose by learning from others — especially if they came up with ideas even better than those of IBM.<sup>66</sup>

At Cornell University, another important Sematech-funded project explored electroless plating. The research produced, among others, three copper interconnects patents jointly assigned to Cornell, Sematech, and Intel.<sup>67</sup> Interestingly, the inventors of these patents included C. Ting, one of the two Intel researchers (and originally from IBM) who had written the initial paper on electroless deposition. This is surely an indication that the knowledge created at IBM and Intel had spilled over to its Sematech partners through this individual. According to researchers I interviewed, the research at Cornell eventually generated data that helped firms realize that electroplating was more feasible than electroless plating.

---

interconnects.

<sup>64</sup> The focus of research at RPI, SUNY, and Cornell is manifest in the publications covered by the Science Citation Index and Dissertation Abstracts Online. References are available upon request.

<sup>65</sup> The work IBM funded at RPI was on low-k dielectrics, a complement to copper technology.

<sup>66</sup> Source: interview with IBM researcher.

<sup>67</sup> U.S. Patents Nos. 5695810, 5824599, and 5891513.

How did companies apart from IBM access knowledge at these universities? Some knowledge was exchanged at conferences attended by a small but expanding community of researchers from around the world who studied copper interconnects.<sup>68</sup> Only broad information was exchanged at these conferences; the academic researchers worked at that level, and firms were unwilling to reveal intimate technical details.<sup>69</sup> Thus, the function of these conferences was to chart the overall research direction.

The movement of people was a much more important channel through which knowledge flowed from the universities to firms. In particular, firms actively recruited graduate students who had worked on copper-related technologies at Sematech-funded universities. Academic researchers reported strong demand for graduates with such experience.<sup>70</sup> One professor mentioned how a graduate student had done a less-than-“marketable” Ph.D., stayed on for post-doctoral research on copper interconnects, and was then snatched up by a company.

The companies that recruited these graduate students — unlike AT&T and IBM — were attempting to hire individuals with domain-specific skills. According to the R&D director at one company, “The people we hired from universities had the right set of skills. They were familiar with specific technical areas, such as plating, sputtering, etc.”

Sematech member companies had an advantage in that regular meetings provided them with an opportunity to evaluate students they might recruit. According to one professor:

---

<sup>68</sup> These included the VLSI Multilayer Interconnect Conference (VMIC) and the IEEE International Electron Devices Meeting (IEDM,) which has special sections on interconnect technology. Between 1991 and 1996, RPI also conducted its own summer meetings.

<sup>69</sup> Several researchers I interviewed described this situation, which is reflected in the content of the papers published in the relevant conference proceedings.

<sup>70</sup> Most academics interviewed reported that their students went into industry rather than academia. According to one Professor, “a much higher percentage of graduate students go to industry compared to MIT, and in this area, even more so.”

In most cases, graduate students went to U.S. industry — especially Sematech companies. This is because Sematech funded the research, and therefore people from Sematech companies were at the annual review, where they had early indications of the quality of the students.<sup>71</sup>

Although Sematech began funding university research around 1988, its in-house copper program did not take off until 1993-95.<sup>72</sup> While the universities played an important role in developing fundamental knowledge, Sematech concentrated on integrating copper into the rest of the manufacturing process. This required working closely with equipment suppliers to develop tools (Table 2-10 lists the public agreements between Sematech and equipment suppliers). Sematech's biggest contribution was its detailed benchmarking tests on equipment. Until then, there was "lots of anecdotal knowledge but no performance data available."<sup>73</sup>

Sematech signed a controversial contract with IBM around 1994 or 1995,<sup>74</sup> under which Sematech paid IBM \$1 million for samples and electrical performance data from IBM's copper process. Sematech wanted to compare IBM's data with the results of Sematech's experiments to deposit copper using CVD, PVD, and electroplating. At the time, IBM did not disclose which of these processes it was using, nor did it send Sematech any completed wafers. However, the IBM data helped Sematech decide to use electroplating instead of the alternatives.<sup>75</sup>

The overall result of Sematech's efforts was that it succeeded, in August 1997, at producing test wafers using copper interconnects.<sup>76</sup>

---

<sup>71</sup> Source: interview.

<sup>72</sup> The material in this paragraph comes from interviews with Sematech and its member companies.

<sup>73</sup> Source: Interview with Sematech personnel.

<sup>74</sup> The information in this paragraph comes from interviews with IBM and Sematech.

<sup>75</sup> Basing themselves on IBM data, several researchers guessed that IBM had used electroplating. But these researchers could not be sure. Around 1996, IBM revealed to Sematech that it was using electrodeposition.

<sup>76</sup> Sematech press release, 11 August 1997 (<http://www.semtech.org/public/news/archive97.htm>).



An important feature of Sematech's in-house development was that except for a handful of publications and patents Sematech filed, the knowledge produced was *made available only to member companies*. Almost all member companies sent assignees on two-year attachments to the Sematech R&D facility in Austin, Texas. Several firms, including AMD, Motorola, and TI, also had research facilities in Austin. The relationship with Sematech gave U.S. firms a strong advantage over their foreign rivals, who were barred from joining Sematech till 1999.

### **IBM as a Source of Spillovers**

Apart from Sematech and the universities, IBM was, of course, the other major source of knowledge between 1989 and 1997. IBM introduced basic ideas that others explored, such as the damascene process and copper CMP. In interviews, several professors mentioned that IBM researchers also occasionally gave them suggestions on suitable questions to investigate (while not sharing proprietary information).

IBM contributed directly useful knowledge in three ways. The first was through its information-sharing contract with Sematech described above. Further, IBM encountered some severe financial difficulties IBM in the early 1990s, which forced the firm to scale back the copper R&D project drastically, and almost shut it down.<sup>77</sup> As a result, several key individuals left IBM to join competitors and equipment suppliers.<sup>78</sup> This flow of people from IBM to other firms was the second way in which IBM contributed useful knowledge, and although the companies who employed these people insisted that their new employees honor their non-disclosure agreements with IBM, it is likely that the firms realized at least an indirect benefit.<sup>79</sup> An analysis of the copper publications shows that only two authors originally affiliated with IBM subsequently changed their corporate

---

<sup>77</sup> This story is recounted in an IBM *Think* magazine article (see bibliography). I have corroborated it through interviews with IBM employees.

<sup>78</sup> Unfortunately, my industry sources have been reluctant to reveal the precise number of people who left IBM's copper program. According to one interviewee, at least three key people departed IBM to join other firms, one of them to Motorola.

<sup>79</sup> The norm in the semiconductor industry is for employees who leave one firm to join another to work on unrelated projects for at least 6-9 months.

addresses. However, this underestimates the actual flow of people from IBM, because some went on to *managerial* positions elsewhere and did not continue to publish.

A third way in which IBM contributed knowledge was through accidental losses. According to one interviewee, “Someone at IBM blundered some information and some people [at an equipment company] figured out that with the right [electroplating] bath it would work beautifully. Now several plating tools have been developed based on the idea.”

### **Motorola as a Source of Spillovers**

Consider the case of Motorola, which highlights the importance of connectedness.<sup>80</sup> Thanks to its PowerPC alliance with IBM (through which the two firms worked jointly to design a microprocessor), Motorola sensed earlier than other companies that IBM was making progress on copper technology. The alliance did not involve the exchange of process technology, but Motorola was able to draw inferences from the design rules employed by IBM when it planned to use copper interconnects. According to an IBM source, “Motorola knew more than anyone else what IBM was doing.”

Motorola also absorbed external information by actively recruiting people from IBM and from Sematech-related universities. At Sematech, Motorola was deeply immersed in the copper program. In fact, the past two consecutive directors of Sematech’s interconnect program were Motorola assignees. Motorola’s relationship with IBM and its strong involvement with Sematech helped the firm to adopt copper technology rapidly, even relative to other Sematech member companies.

Motorola’s ability to be connected to outside research did not depend on performing early-stage R&D (recall that the firm published only three articles on the subject). According to a Motorola employee, the company “operated in tactical mode” to integrate external knowledge with its own talent. But while it was clearly dependent on

external technology, Motorola was also more open about sharing its knowledge than IBM. For example, Motorola worked jointly with suppliers from an early stage to develop tools for copper technology. A member of Motorola’s copper team remarked that “unlike IBM, we are quite open with vendors. There are vendors down there in the fabs! Most other companies would not allow it.”

Motorola’s relative openness — coupled with IBM’s secrecy — would eventually make the firm an important source of information for the rest of the industry. Table 2-3 shows that citations of Motorola’s copper patents rank second only to those of IBM. And Table 2-8 shows that the most highly cited patent on copper interconnect technology belongs to Motorola.

**Table 2-8: Patents Most Highly Cited by Copper Interconnect Patents (1960-1999)**

Patent No	Patent Assignee	Title	No of citations to this patent
5391517	Motorola	Process for forming copper interconnect structure	16
4810332	MCC*	Method of making an electrical multilayer copper interconnect	13
4985750	Fujitsu	Semiconductor device using copper metallization.	12
4789648	IBM	Method for producing coplanar multi-level metal/insulator films on a substrate and for forming patterned conductive lines simultaneously with stud vias	11
4910169	Fujitsu	Method of producing semiconductor device [including copper]	10
4931410	Hitachi	Process for producing semiconductor integrated circuit device having copper interconnections and/or wirings, and device produced	9
4944836	IBM	Chem-mech polishing method for producing coplanar metal/insulator films on a substrate	8
5225034	Micron	Method of chemical mechanical polishing predominantly copper containing metal layers in semiconductor processing	7
5447599	Cornell & IBM	Self-aligned process for capping copper lines	7
5071518	MCC*	Method of making an electrical multilayer interconnect [by electroplating Copper]	7

MCC\* = Microelectronics and Computer Technology Corp. of Austin, Texas, an industrial research consortium (<http://www.mcc.com>).

<sup>80</sup> The material in this paragraph was obtained through interviews with Motorola and IBM.

In summary, between 1989 and 1997, companies and universities re-explored the path that IBM had shown, in turn developing their own variants based on the same basic ideas.<sup>81</sup> These borrowed ideas are true knowledge spillovers. They account for why IBM was so secretive, and at the same time produced research that was so highly cited. The ability to absorb spillovers was greatly enhanced for firms that had relationships with Sematech, universities and IBM. Sematech helped to fund crucial university research and offered its members benchmarking data on equipment suppliers, access to data on IBM's copper technology and an advantageous position in recruiting talent from universities. It is no surprise that foreign firms who were barred from joining Sematech (such as NTT and Hitachi) were slow to develop and adopt copper technology, even though they performed early research on it.

At one level, these facts are consistent with stylized notions of absorptive capacity (IBM performed fundamental research and captured knowledge spillovers). But IBM did not have to be open with its own research in order to keep up with university research. And the success of Motorola, TI and AMD at capturing spillovers from universities and other external sources were not predicated on their having to perform much of the early research.

#### **2.4.3.2 Knowledge Spillovers after 1997**

IBM's 1997 announcement of its copper technology triggered a race among other firms to offer copper technology as well (Lineback, 1998; Dagastine, 1998). This contest radically changed the dynamics of knowledge-flow. Firms could no longer rely on the relatively slow process of converting academic knowledge into a commercial product. Besides, some companies had already done so, including Motorola and the equipment vendors. Alliances and joint ventures formed rapidly between firms that wanted the

---

<sup>81</sup> That these processes are sufficiently different in their details from IBM's is evidenced by the fact that other companies received patents (for which novelty is required) on their inventions. Likewise, some originality can be expected of research papers that qualify for publication.

**Table 2-9: Copper Alliances, Joint Ventures, and Acquisitions among Semiconductor Firms**

<b>Date</b>	<b>Companies</b>	<b>Nature of Alliance</b>
Pre-1988	NONE	NONE
July 1998	AMD and Motorola	Motorola licenses its copper interconnect technology to AMD. In exchange, AMD licenses Motorola its flash memory processes. This seven-year deal includes the exchange of technology, sharing development costs, and assigning employees to one another's design labs. No money is exchanged.
July 1998	IBM & Sanyo	In a five-year agreement, Sanyo licenses design methodology from IBM, including ASIC and copper technology. IBM will manufacture the devices.
July 1998	Sun and TI	TI will manufacture Sun's UltraSparc III using copper in year 2000.
Mar. 1999	IBM and Infineon (Siemens)	IBM gives Infineon access to copper technology (0.18 and 0.13 micron) for joint development of DRAMs.
Dec. 1998	IBM and Pacific Electric Wire & Cable	IBM licensed its technology, including copper, to this new Taiwanese foundry.
Mar. 1999	Lucent (AT&T) and Chartered Semiconductors, Singapore	Lucent and Chartered agree to joint development of 0.18 micron copper technology.
Feb. 1999	Motorola, Hewlett-Packard and Chartered	Motorola licensed its copper technology to a joint venture between Chartered Semiconductor Singapore and Hewlett Packard (0.18 micron copper with low-k dielectrics).
Mar. 1999	UMC Taiwan and Kawasaki LSI Japan	Strategic alliance to develop 0.18 micron copper technology with copper and low-k dielectric.
Jan. 2000	UMC joins the alliance between IBM and Infineon	Joint development of 0.13 micron technology, including copper interconnects.
NA	Lucent-NEC	Long-term agreement that includes copper interconnects

Sources: News articles, company websites, and interviews.

**Table 2-10: Copper Alliances, Joint Ventures, and Acquisitions Involving Suppliers**

<b>Date</b>	<b>Companies</b>	<b>Nature of Alliance</b>
<b><i>Companies and Equipment Suppliers</i></b>		
1997-	Intel and Applied Materials	Research on copper etch as an alternative to damascene (IEEE Conference 1-3 June 1998)
July 1998	AMD & Applied Materials	AMD ordered Applied Ion Metal Plasma technology to develop copper interconnects
1998	AMD & CuTek	Joint venture. Purpose unknown.
1999	TSMC and Applied Materials	TSMC purchases AMAT copper-processing machine.
1999	UMC and the Novellus Alliance	Collaborated on copper interconnect process.
<b><i>Sematech and Equipment Suppliers</i></b>		
1993	Sematech and Semitool	Sematech bought Semitool's electroplating tool for experiments on copper interconnects.
Sep. 1996	Sematech and Varian	Sematech bought a PVD/CVD cluster tool for the Sematech project at SUNY Albany.
May 1998	Sematech and Applied Materials	Second phase of project to etch low-k materials for copper interconnects
1996	Sematech and CVC (Rochester)	Developed copper deposition tool
Nov. 1997	Sematech and Lam Research	Developed high-density oxide etch systems
Jan. 1999	Sematech and Novellus	Sematech selected Novellus' Sabre electrofill tool for its Advanced Tool Development Facility.
<b><i>Equipment Supplier Alliances</i></b>		
1997	Novellus and Varian (thin-films division)	Novellus acquired Varian's thin-films unit, thereby acquiring the PVD expertise it used in developing tools with IBM.
May 1998	Novellus, Lam, IPEC and OnTrak	Novellus announced partnerships with Lam and IPEC to provide a complete copper solution. Novellus offers an electrodeposition tool and a PVD tool (for barrier and seed layers); IPEC is market leader in CMP. Lam produces dielectric-etch systems, and Ontrak supplies post-CMP cleaning systems.
Jan 1998	Semitool and Shipley	Semitool partners with Shipley, a electronic chemicals company
Nov. 1998	Semitool and Ulvac, Japan	Semitool (electrochemical deposition) partners with Ulvac (thin-film deposition equipment)
1999	Semitool and ASM (Netherlands)	Semitool (copper electrodeposition tools), forms an alliance with ASMI (CVD tools for low-k dielectric).

Sources: News articles, company websites, and interviews.

technology and firms with the expertise (see Tables 2-9, 2-10).<sup>82</sup> Even IBM became less secretive and began to seek ways to license or trade its technology. Third-party information traders also materialized, such as a company that began selling reverse-engineering reports of IBM's copper-based chips almost as soon as they were shipped.<sup>83</sup>

It is important to distinguish the relationships that involved "borrowed" ideas from those that simply reflect inputs purchased below their actual costs (Griliches, 1992). The alliances involving IBM probably should not be viewed as true spillovers, since IBM must have expected reciprocal benefits. Neither should the manufacturing alliances (e.g., Sun and TI). However, technology-sharing alliances that did not involve IBM should be considered true spillovers from IBM's perspective (even though they are not externalities among the alliance partners). For example, the alliance between Motorola and AMD did not involve payments by either party to IBM.<sup>84</sup> As for the equipment suppliers, IBM receives an unspecified royalty from Novellus with whom it jointly developed tools.<sup>85</sup> However, IBM receives no royalties from any of the other equipment suppliers, including Applied Materials, Semitool, and Cutek. More important, equipment vendors act as conduits through which much more information flows than is embodied in the tools they sell.<sup>86</sup> Hence, it is reasonable to consider knowledge flows from equipment vendors as externalities, or as General Purpose Technologies (Bresnahan and Trajtenberg 1995).

---

<sup>82</sup> Note that no alliances existed prior to 1998, reinforcing the fact that the dynamics had shifted.

<sup>83</sup> Integrated Circuit Engineering Report #SCA 9808-587 advertisement: "ICE Corp. is excited to announce the immediate availability of a construction analysis report on the recently announced IBM PowerPC 750 ... This report represents one of the most detailed reports ICE has ever produced ..."  
(Source: ICE website.)

<sup>84</sup> Semiconductor companies often exchange patents with one another (Hall and Ham, 1999). IBM may be able to appropriate some benefit through such *ex-post* bargaining, but it is difficult to monitor and implement (which is why negotiations are for portfolios of patents rather than for specific technologies). Moreover, other firms also have strong patent positions, including Motorola, AMD, and TI (see Table 2-6). Their bargaining positions against IBM would, therefore, be strong.

<sup>85</sup> According to IBM sources, this amount is low in relation to the benefits of being early to market.

<sup>86</sup> This point was made to me by numerous interviewees.

Perhaps the most viable of the alliances formed after 1997 was that between AMD and Motorola.<sup>87</sup> AMD had been very aggressive in developing its copper technology and in May 1998 announced two test-chips (Wolfe 1998a).<sup>88</sup> However, the firm needed to accelerate its effort. So, AMD signed a major agreement in July 1998 to trade its flash memory technology for Motorola's copper interconnect technology (Matsumoto 1998). Motorola's technology formed the basis for AMD's new production facility in Germany, which began producing samples of copper-based Athlon microprocessors at the end of 1999.<sup>89</sup> The seven-year agreement also includes the joint-development of Motorola's next generation of copper technology.

Chartered Semiconductors, a chip foundry based in Singapore, also drew upon Motorola's expertise. In 1999, Chartered licensed Motorola's technology for a manufacturing facility jointly owned by Chartered and Hewlett-Packard (see Table 2-9). Chartered's dependence on Motorola technology accounts for the fact that its patents make a large number of references to Motorola's patents (see Table 2-2). Also in 1999, Chartered signed an agreement with Lucent Technologies for joint development of copper interconnect technology.<sup>90</sup>

Chartered also has depended upon knowledge from universities in Singapore. It funded several students at these institutions who conducted research on copper interconnects and who, upon completion of their studies, were obliged to join the company. The knowledge from Motorola, Lucent, and the universities will help

---

<sup>87</sup> As shown in Table 2-1, Motorola was only 1 year behind IBM at shipping copper-based chips. AMD was less than 2 years behind IBM.

<sup>88</sup> AMD's copper program began around 1995 and grew very rapidly. Interestingly, it hired C. Ting who had previously worked at IBM, Intel and Sematech, as evidenced by the fact that Ting is listed as an inventor in one of AMD's patents (see U.S. patent No. 5969422). Ting eventually left to form his own equipment company focussing on copper interconnects (see the founder's biography at <http://www.cutek.com>).

<sup>89</sup> Volume shipment will begin in mid-2000. These chips will compete with Intel's Pentium III chips (see Cataldo, 2000). Motorola eventually took an equity stake in AMD's copper fabrication plant (*EETimes*, September 20, 1999).

<sup>90</sup> The agreements with Motorola and Lucent are for different applications, and are managed separately within Chartered in order to protect the intellectual property of each partner.



Chartered ship its first copper products in 2001, only four years after commencing R&D.<sup>91</sup>

The Taiwanese chip foundries (TSMC and UMC) adopted copper interconnect technology with the greatest speed.<sup>92</sup> Both began copper R&D programs in mid-1998 and, at the end of 1999, shipped IC chips with the top two metal layers made from copper.<sup>93</sup> According to my interviews, TSMC and UMC depended primarily on technical knowledge from equipment suppliers.<sup>94,95</sup> TSMC worked closely with Applied Materials, while UMC was one of first customers of Novellus (which had jointly developed tools with IBM).<sup>96</sup> According to one interviewee, “Taiwanese [semiconductor firms] bring everything up and co-develop technology with vendors. This way they minimize risk because they have no early-stage [sic] research.”

There are several other similarities between TSMC and UMC. Both recruited highly trained personnel, including people who received their graduate-level education at top universities in Taiwan and the United States; some had also worked at U.S. companies. Yet, neither firm perceived a *direct* relationship between university research and their copper projects.<sup>97</sup> One interviewee characterized university research as being

in the literature [and] available for years. It’s helpful, but they are pure research — basic, fundamental studies. But to make things work is really different [sic].

---

<sup>91</sup> Chartered also relied on samples and tools obtained from equipment vendors and on process-integration consultants with previous copper experience.

<sup>92</sup> VLSI Technology, a U.S. foundry, followed the same rapid adoption pattern and also shipped IC chips with two-level copper interconnects around the same time as UMC and TSMC.

<sup>93</sup> IBM and Motorola use six layers of copper. By 2000, UMC and TSMC will be offering six-layer copper interconnects as well.

<sup>94</sup> Researchers at VLSI tell a similar story of how they depended mainly on equipment suppliers for technical knowledge.

<sup>95</sup> In January 2000, UMC joined an alliance with IBM Microelectronics and Infineon (Siemens) to co-develop process technology (including copper) for 0.13 micron chips (Clarke 2000). However, this was after UMC had developed in-house capabilities and shipped copper products by the end of 1999.

<sup>96</sup> UMC’s relationship with Novellus is reported in a UMC press release dated 12 April, 1999.

<sup>97</sup> UMC funds the UMC Chair Professorship in the Department of Electrical Engineering, National Chiao Tung University. In November 1999, UMC became the first foreign member of the Semiconductor Research Corporation (SRC). Also in 1999, TSMC joined Sematech and began collaborating with MIT. By then, both companies had already developed their copper capabilities. They look towards these relationships for future knowledge on interconnects and in other areas.

Another interesting similarity is that while the copper development teams at both companies had highly talented people, they did not include individuals with extensive prior experience with copper interconnects. Because much of the technical knowledge came from equipment suppliers, the primary role of internal teams was to integrate the knowledge of suppliers into their manufacturing processes.

TSMC and UMC are only the first in a larger wave of companies that depend primarily on equipment vendors. How do these equipment companies, which perform little R&D, absorb external knowledge?<sup>98</sup> While Novellus certainly benefited from its work with IBM, that alone was not sufficient. Novellus drew upon another important source of external knowledge: in 1997, it acquired PVD capability by purchasing Varian Associates' thin-films division.<sup>99</sup> Varian had been the main supplier for the Sematech-funded copper project at SUNY Albany.<sup>100</sup> Novellus provides an interesting example of how absorptive capacity can be enhanced through a technological acquisition.

As for Applied Materials, it claims that its primary source of knowledge was “working with customers,” which include Motorola, AMD, Intel, and Fujitsu.<sup>101</sup> Apart from maintaining relationships with customers, equipment vendors also built strong ties with universities. Applied Materials funds \$1 million a year of research at universities. Novellus is a member of the SRC and also has a board member who is an MIT professor.<sup>102</sup> According to several equipment companies, the primary benefit of such relationships is the opportunity to recruit top-notch graduate students who are assigned to

---

<sup>98</sup> Even the largest equipment vendor, Applied Materials, does not have a central R&D laboratory. While a central group develops common platforms for its business groups, it is not a traditional “central R&D” facility that performs a great deal of research. R&D is financed and performed mainly by business units. An interview with a manager revealed that the business units spend 5% of their budget on “basic” research, but only in areas where there is a strong chance it will generate commercial products in the future.

<sup>99</sup> PVD is used to deposit the seed and barrier layers in a damascene process.

<sup>100</sup> Source: *BusinessWire*, Sept. 12, 1996, p. 9120025.

<sup>101</sup> I constructed this partial list of Applied's customers from news reports and co-authored articles on copper interconnects presented at technical conferences.

<sup>102</sup> I obtained information about the Novellus board from the firm's 1999 Annual Report.

the early stage of development projects, bringing with them a wealth of scientific expertise.

The equipment companies play an increasing role in transferring knowledge from early developers (IBM, Motorola) to later adopters (e.g., TSMC, UMC). This is a difficult task because each piece of equipment is only a small part of the overall puzzle of putting together a copper process. To fill the void in their knowledge, equipment companies have coalesced into alliances that provide complete solutions. The first such alliance was created in 1998 by Novellus, Lam Research, IPEC, and Ontrak (see Table 2-10).<sup>103</sup> It was followed by another alliance led by Semitool. The exception to this pattern of alliances is Applied Materials, which is large and horizontally integrated. In 1998, the firm began offering an integrated set of tools for copper interconnects.<sup>104</sup> It also opened a service center where customers can “test-drive” this technology.

As a result of the work by equipment companies, much of the technical knowledge had become “unstuck” (von Hippel, 1994) by the end of 1999. Adoption has since begun to depend on other issues, such as how to organize a facility to avoid copper contamination and whether to invest in a new facility or deploy copper technology into an existing facility.

## 2.5 Discussion

In Section 2.5.1, I discuss other factors that may have influenced the costs and benefits of adoption, and how this affects the interpretation of the results. In Section 2.5.2, I explore why IBM pursued copper interconnect R&D despite the rapid rate of spillovers, and why it published its research. And in Section 2.5.3, I discuss IBM’s approach to capturing spillovers at the disciplinary level, as opposed to at the domain-specific level.

---

<sup>103</sup> Source: *BusinessWire*, May 28, 1998, p5280060. (see also <http://www.novellus.com>).

<sup>104</sup> Source: Company press release dated Nov. 3, 1998.

### 2.5.1 Other Factors that Affected Adoption

There are two “dependent” variables in my analysis: the date on which firms shipped their first products, and the duration from the start of their R&D to that shipment date (see Table 2-1). However, unobserved factors could have influenced the costs and benefits of adoption. This affects the comparison between firms with and without prior R&D. Specifically, firms with prior R&D may have *chosen* not to adopt copper technology due to different anticipated costs and benefits, rather than being *unable* to absorb spillovers as quickly.

Heterogeneity in adoption costs is unlikely to be significant. Semiconductor companies all buy equipment and raw materials from the same handful of suppliers, and the only commercial option right now is damascene electroplating. However, firms are likely to have different expected benefits. Certain segments of the market that demand high-performance and low power-consumption are likely to see earlier adoption, such as microprocessors (AMD, Motorola, IBM) and portable telecommunications devices (Motorola, TI). In addition, the chip foundries (TSMC, UMC, VLSI and Chartered) had strong reasons to adopt copper technology because IBM Microelectronics is now an aggressive competitor in the foundry business.

However, anticipated benefits alone cannot explain why several companies such as Lucent, NEC, Hitachi, and Intel were slower to adopt copper technology. These companies *also compete in the product spaces with high expected benefits*.<sup>105</sup> Intel claims that it decided not to adopt copper technology until 2002 because it has developed other ways of achieving the same performance using aluminum interconnects with low-k dielectrics (McGrath, 1998). But other companies (IBM, Motorola, and TI) have already created prototype chips that incorporate *both* copper and low-k dielectrics, so choosing

---

<sup>105</sup> Intel is the world’s leading microprocessor company. Hitachi and NEC produce mainframe computers. NEC and Lucent compete in telecommunications (including the mobile market).

one over the other isn't necessarily a tradeoff.<sup>106</sup> It is revealing that Intel was on the list of companies to which IBM prevented Novellus from selling.<sup>107</sup> And it is hard to imagine that copper technology would not help Intel as the race to build better microprocessors intensifies.<sup>108</sup>

There are other reasons to doubt that the benefits of adoption were much lower for companies like Intel, Lucent, Hitachi, and NEC. The fast adoption of a new technology — particularly in the semiconductor industry — allows a firm to descend the learning curve quickly (Spence 1984). This is a main reason for the intensity of the race to adopt copper after 1997. Shortly after IBM's announcement, a news article quoted the manager of interconnects at Texas Instruments: "Everybody wants to be second, after IBM ... Nobody is going to get caught out on this" (Lammers, 1997).

Although unlikely, it remains possible that some firms chose not to adopt copper rapidly for other reasons, even though they had performed related R&D. Therefore, it is difficult to draw conclusions about the effectiveness of internal R&D relative to other means of developing absorptive capacity.

Regardless of the costs and benefits of adoption, one must still account for how firms such as Motorola, AMD, and the foundries captured spillovers rapidly from IBM and academia *without* performing much prior R&D. In other words, unobserved costs and benefits do not explain the early shipment dates of these firms relative to IBM. Here, the results are stronger: in the previous section I show that the ability of firms to absorb spillovers rapidly was facilitated by their connectedness to external sources of technical knowledge.

---

<sup>106</sup> On IBM's copper plus low-k dielectric, see Markoff (2000). On Motorola's efforts, see Wils on (1999).

<sup>107</sup> This fact is well-known within the semiconductor industry. However, Intel has been working with Applied Materials to develop its own copper technology (e.g., see Koch *et al.*, 1999).

<sup>108</sup> In late-1999, AMD became the first company in history to unveil microprocessors for personal computers that were faster than Intel's. In January 2000, Transmeta began production of an extremely

## 2.5.2 Why did IBM innovate and why did the Firm Publish?

In view of the rapid spillovers, why did IBM bother to invest in copper interconnect research over three decades? Through a variety of means described below, IBM could appropriate (or expected to appropriate) some of the returns from innovation. While the firm will capture less than the value it created, this does not conflict with theory. Nelson and Arrow do not suggest that firms faced with spillovers would invest nothing, only that they would invest *less* than is socially optimal.

When IBM initially began investing in copper technology during the 1960s, the company had expected to use copper in the mainframe computers market, for which its expected appropriability was high. IBM had initially intended copper for super-fast bipolar devices in mainframes.<sup>109</sup> Such devices operate very high current loads that place great demands on interconnects. This was (and continues to be) a market in which IBM held the dominant position and enjoyed high margins.

In the early 1990s, IBM researchers realized that CMOS technology — which dissipates less heat and is less demanding on interconnects — would overtake bipolar. Having lost the initial motivation to pursue copper and faced with IBM's financial distress at the time, senior managers drastically scaled back the copper project. It survived for about a year as a “skunk-work” project within the organization.

One year later, the project was picked up by a new internal customer, IBM Microelectronics, which realized that copper interconnects would be needed for CMOS sooner than expected. Unlike for the mainframe market, IBM's expected lead from CMOS would be more transitory. So, IBM Microelectronics invested aggressively to

---

low-powered processor for mobile internet computers built using IBM's copper technology (source: <http://www.transmeta.com>).

<sup>109</sup> Material from this paragraph was obtained from the IBM *Think* magazine article, the *IBM R&D Magazine* article, the *EETimes* special issue, and interviews with IBM employees.

make the process cost-competitive by switching from polyimide to silicon dioxide as the dielectric material and moving from single to dual damascene.

The firm eventually obtained a lead of one to two years in the marketplace — significant in the fast-paced semiconductor industry. This lead allowed IBM to ship more than a million copper chips ahead of its competitors.<sup>110</sup> More important, IBM is ahead of its competitors on the learning curve and has the highest process yields using copper.<sup>111</sup> Being first to market also brought other benefits: it boosted IBM's market visibility and demand for its products. IBM has also begun to exploit economies of scope, extending the use of copper technology into other areas such as servers and mainframes and successfully combining copper with low-k dielectrics and silicon-germanium technology.<sup>112</sup>

IBM is also attempting to capture indirect benefits. According to my interviews, several IBM employees realized in the mid-1990s that the company would benefit from lower equipment costs if the rest of the industry also adopted copper technology.<sup>113</sup> This is consistent with the literature on the strategic sharing of information.<sup>114</sup> In line with this, IBM relied on an external supplier for the equipment (Novellus) and later relaxed its secrecy to a degree. Although it continues to guard sensitive process information, IBM has also begun to share its copper technology with other companies, including Siemens (Infineon), Sanyo, and a startup foundry in Taiwan (see Table 2-9). It is important to point out, though, that this strategy of sharing technology was only feasible once IBM had established itself as the leader. Otherwise, another firm might have exploited the knowledge to beat IBM to market.

---

<sup>110</sup> Source: IBM Press Release, Sept. 23, 1999.

<sup>111</sup> According to industry interviews, IBM is the only company with yields from its copper process approaching that of aluminum. The electrical properties of the copper exceed those of aluminum.

<sup>112</sup> Sources: CNN, Dec. 3, 1999; *The New York Times*, April 3, 2000.

<sup>113</sup> IBM represents a small share of the equipment industry's production capacity. The firm wants to spread out the fixed costs of equipment suppliers over more units sold.

<sup>114</sup> Firms may *deliberately* share knowledge if this increases the demand for their products (Harhoff, 1996). According to Gawer (2000), Intel invests in R&D activities that they willingly share with other

A separate but equally intriguing question is why IBM published at all in the open literature. After all, these publications were useful to other researchers who were trying to retrace IBM's footsteps. According to researchers at IBM and elsewhere, *IBM chose to publish general ideas but kept valuable process-specific information and recipes proprietary*: "IBM shared information that didn't fall into their crown jewel capability."<sup>115</sup>

IBM's approach to publication explains why IBM refrained from patenting till the mid-1990s, since patenting entails heavy disclosure requirements. However, if IBM hadn't allowed anything to be published at all, it would have had difficulty getting talented individuals to work on the project.<sup>116</sup> Also, many innovations (e.g., damascene, CMP) were developed within IBM but outside the copper group. To keep everything under wraps probably would have required a firm-wide policy of non-publication. Finally, the emergence of publications by academics after 1989 may have acted as a catalyst.<sup>117</sup> In other words, had IBM not published its work, someone else would have done so. According to one professor, "With copper or damascene, when we publish something, IBM starts to publish also." This pattern of behavior could account for why IBM's publication rate increased in the 1990s, after universities and other firms also began to publish (see Table 2-5).

### 2.5.3 IBM's Dependence on Disciplinary Spillovers

In contrast to other companies and in line with its efforts to preserve secrecy, IBM's efforts to develop copper interconnect technology depended very much on *internal* knowledge. As Table 2-2 shows, IBM's copper patents cite the company's own patents more than they cite patents from any other organization. This is consistent even if

---

firms, in the hope that those firms develop complementary products, thereby increasing the demand for Intel's products.

<sup>115</sup> Source: Interview with an academic researcher.

<sup>116</sup> In other words, the Stern (1999) "premium" would have been high.



we only count citations to patents related to copper interconnects (see Table 2-3). Likewise, the citations made by IBM patents to the scientific literature make the largest number of references to articles published by IBM (see Table 2-4). This is unsurprising, since IBM's Watson Laboratories did much of the fundamental research on copper interconnects.

If IBM depended at all on external knowledge, it was at a broad, disciplinary level, rather than for knowledge specific to copper interconnect technology. Interviewees at IBM emphasized the company's primary policy of recruiting top-notch researchers directly from graduate programs and allowing them to pursue interesting problems at IBM, rather than hiring people with domain-specific knowledge. In fact, IBM's Watson Laboratories has never hired anyone to work on its copper R&D who had previously worked on copper at other firms, or had written a Ph.D. thesis on the topic.<sup>118</sup> Rather, IBM's copper project depended upon internal sources of technical knowledge: IBM employees who had helped create the damascene process and CMP technology, electrochemists familiar with electrodeposition for chip-packaging, a physicist who developed the barrier layer, materials scientists who understood corrosion and device-failure, and in-house process integration experts.<sup>119</sup>

## 2.6 Conclusions

The case of copper interconnects offers a rare glimpse into the process of knowledge spillovers, one that is much talked about but seldom observed up close. The case shows that the mechanisms of absorptive capacity are more complex than the literature has suggested.

---

<sup>117</sup> This was suggested to me by an academic researcher who worked on copper interconnects.

<sup>118</sup> Unlike the Watson Laboratories that does *fundamental* research, IBM's *development* team hired one person who had completed a Ph.D. thesis on copper interconnects around 1994. (Source: interviews and analysis of Dissertation Abstracts Online).

<sup>119</sup> The team did *not* include people who had worked on aluminum-copper interconnects, which is not directly related. This further supports the point that copper depended upon different skills.

To a first order, absorptive capacity depends on both a firm's internal R&D and its connectedness to external technical knowledge. There are many ways of achieving connectedness, with other means being at least as effective as internal R&D. These include relationships with universities, research consortia, and other companies that possess relevant technology.

This case further illustrates that the openness of a firm's research environment may not be necessary for connectedness (as with IBM). And it suggests that different kinds of absorptive capacity exist. Specifically, investments in internal R&D may improve the absorption of disciplinary knowledge, while other methods may be more useful for absorbing domain-specific knowledge.

One implication of this view is that while prior R&D may increase a firm's absorptive capacity, the multitude of alternatives makes it difficult to overcome externalities. Unless many firms choose to perform R&D rather than using alternative means for acquiring absorptive capacity, the aggregate amount of R&D invested by all firms is unlikely to be sufficient to overcome the underinvestment problem caused by spillovers. Another implication is that it is extremely hard to contain spillovers. Because there are so many ways of achieving connectedness, blocking one path may simply encourage firms to try another. This is consonant with prior research showing that technological knowledge diffuses very rapidly (Mansfield, 1985).<sup>120</sup>

There is a need for future research to explore whether the insights from this study hold outside the semiconductor industry. Further investigation is needed as well to understand the relative effectiveness of internal research versus other means for acquiring absorptive capacity. Research is also needed on the relationship between absorptive capacity and financial outcomes. And most important, we must learn why some firms are

---

<sup>120</sup> Mansfield (1985) reports that product innovations are generally in the hands of rivals within a year and that process innovations (except for chemical processes) leak out within 15 months.

better connected than others are — and how this is explained by economic, social and institutional factors.

## Appendix 2-A: Construction of Data Set

### U.S. Patents

I obtained patents awarded by the U.S. Patent and Trademarks office between January 1976 and December 1999 relating to copper interconnects (U.S. patent data is available in electronic format only for this period). I searched the database for:

- (1) All patents with titles and abstracts containing the keywords (“cu” or “copper”) and “intercon\*<sup>121</sup>.”
- (2) All patents with titles and abstracts containing the keywords “damascene.”
- (3) Patents in the two main semiconductor patent classes (257 and 438) containing the keyword “copper.”

I downloaded each of these patents and manually identified those directly related to copper interconnects, based on each patent’s title and abstract.<sup>122</sup> Where ambiguity arose, I consulted the “background” section of the patent, which clearly describes the patent’s purpose. I then downloaded and similarly coded the references made by these patents to other U.S. patents, repeating the process repeated two additional times to ensure that I obtained practically all the patents relating to copper interconnect.

The final database contains 2440 patents, of which only 216 are directly related to copper interconnects. Of those remaining, 159 patents involve interconnect technology not specific to copper and another 283 involve copper processing techniques not specific to interconnects. Some of these may have an indirect relationship to copper interconnect technology, but were eliminated from the analysis as a conservative measure.<sup>123</sup> Another group of patents were safely eliminated, including 62 patents for damascene processes

---

<sup>121</sup> When used in a search, an asterisk (\*) acts as a wildcard that matches one or more characters.

<sup>122</sup> These are based on the “relevant” skills identified in section 3.3. My field interviews, attendance at technical conferences, and engineering background provided technical knowledge that was immensely helpful in identifying patents and publications directly related to copper interconnect technology.

<sup>123</sup> I underestimate the number of patents awarded to each firm, but the bias should not be great. By industry estimates, IBM has about 50 patents issued or pending dealing with copper technology (Newsbytes, 13 Jan. 1998). For this paper, I traced 37 IBM patents directly related to copper technology.

that do not use copper, 54 patents for traditional aluminum interconnects, and 48 patents for aluminum-copper interconnects (which are an extension of the aluminum process). The other 1618 patents were completely unrelated to on-chip interconnects,<sup>124</sup> reflecting the breadth of the search and the presence of patents cited by copper interconnect patents that are not themselves related to copper interconnects.

I identified the organization that owns each patent using its “assignee” field. I then generated a cross-reference of citations by patents on copper interconnects to all other U.S. patents. To provide an exhaustive analysis, I include all cited patents as far back as 1960. I looked up patents prior to 1976 in the *Patent Gazettes* printed by the U.S. Patent Office, as these are unavailable in electronic form.

The next step was to create a cross-reference of the scientific publications cited by each copper interconnect patent. To do so, I obtained the address of the first author of each cited publication from the Science Citation Index, Compendex, INSPEC, and the IEEE Online Library.<sup>125</sup> I then constructed a matrix showing the sources of scientific publications cited by each organization’s patents.

## **Publications**

I searched the Science Citation Index (SCI) for all scientific publications with titles containing “Copper\*” or “Cu” and at least one of the following keywords:

- intercon\*
- metalliz\*
- ULSI
- VLSI

---

<sup>124</sup> These included patents for creating copper connections between integrated circuits and the packages in which they are mounted, printed circuit board connections, solar cells, superconductors, heat sinks, heat pumps, components for electric motors, electric power transmission, electroconductive paints, etc.

<sup>125</sup> It was necessary to use numerous databases, as each source covers different journals and conferences. The SCI has an excellent coverage of scientific journals, while Compendex and INSPEC have better coverage of engineering journals. I used the IEEE library to find papers presented at conferences not

- damascene
- etch
- planari\*
- CMP
- barrier
- deposition
- PVD
- CVD

The search produced 1017 publications between 1985 and 1997. I then manually identified those related directly to copper interconnect technology, based on their titles. Of the 1017 publications, only 502 were directly related to copper interconnects.<sup>126</sup> I then eliminated all meeting abstracts, review articles, notes, and letters to obtain a final sample of 413 original research articles.

I mapped each article to companies and public-sector research organizations, based on the address field of its authors. The SCI records up to 255 authors per publication. Unfortunately, it does not indicate which authors are associated with each address. Thus, I adopt the following convention: for each distinct address listed in an article, I increment by one the number of articles published by that organization. The rationale is that each publication involves costly research plus the opportunity cost of writing and revising the

---

covered by the other databases. With the exception of the SCI, these databases include only the affiliations of the first author.

<sup>126</sup> The remaining publications consisted of 47 articles on aluminum-copper interconnects, 89 articles on copper films not specific to interconnects, and 379 articles in unrelated areas (e.g., general copper chemistry, copper printed circuit boards, geological copper deposits, and superconducting alloys containing copper).

paper. This approach counts articles that are co-authored among organizations multiple times, but this should not be a severe problem: only 32 articles in the sample were co-authored among organizations.





## Chapter 3:

# The Concentration of Basic and Applied Research In the Semiconductor and Pharmaceutical Industries: Implications for Theories of Knowledge Spillovers

This chapter estimates the concentration of basic and applied research relative to innovation in the semiconductor and pharmaceutical industries (1985-1997) using publication and patent data. In the pharmaceutical industry, basic research and innovation are equally widespread. However, in the semiconductor industry, basic research is concentrated in only a few firms, although innovation is widespread. I interpret this to mean that many semiconductor firms capture knowledge spillovers without performing much basic research. The alternative explanation is that many semiconductor firms are *not capturing spillovers*, but are more productive at R&D instead. This is unlikely: researchers at these firms co-author papers with academics at a very high rate.

### 3.1 Introduction

To what extent is research activity concentrated in only a few firms in an industry, relative to overall innovation in that industry? More specifically, are there differences between basic and applied research with respect to their concentration relative to innovation? A gap between research activity and innovation could arise because some firms are more productive than others in translating research into innovations, or because some firms are more successful than others at capturing knowledge spillovers.<sup>127</sup> Hence, studying this gap may inform our understanding of how spillovers are related to basic and applied research.

---

<sup>127</sup> In this paper, “spillovers” include knowledge obtained from other companies, academic institutions, industry consortia, and government research laboratories.

In this chapter, I estimate the concentration of both basic research and applied research, relative to innovation, for the semiconductor and pharmaceutical industries. Basic research in the semiconductor industry includes efforts to understand the physics of solid-state devices and the chemical reactions used to fabricate integrated circuits.<sup>128</sup> For pharmaceuticals, basic research explores the bio-molecular and genetic mechanisms of diseases associated with rational drug design (Cockburn *et al.*, 1999).

I measure basic and applied research output using the number of scientific articles published by each company; I measure innovation using patent counts. I find that a surprisingly large number of innovations in the semiconductor industry emerge from companies that perform little basic research. In the pharmaceutical industry, however, basic research is not concentrated relative to innovation. In both industries, the concentration of applied research is similar to that of innovation. The results are robust to several alternative measures of “applied” versus “basic” research (see Appendix 3-B).

While other explanations are possible, one likely interpretation of these results is that firms in the semiconductor industry are able to capture spillovers without performing a great deal of basic research. Instead, they rely on other means, including by funding basic research at universities, co-authoring papers with academics, inviting external researchers to join their scientific advisory boards, and hiring graduating Ph.D. students from leading schools.

The main alternative explanation for these results is that firms that did little basic research, while not capturing spillovers, were more productive at innovation. However, this explanation is unlikely to hold — for two reasons. The practice of co-authoring papers with academic institutions is as widespread as innovation. Isn't it likely that knowledge is exchanged in the intimate meetings of minds required to co-author papers?

Further, there is a plethora of previous research showing that spillovers are significant in both of these industries.<sup>129</sup> Nonetheless, other interpretations of these results are possible, and will need to be further investigated.

Another empirical regularity observed is that the gap between basic research and innovation in the semiconductor industry narrowed considerably between 1985 and 1997. These may have been the result of financial difficulties at IBM and AT&T, which triggered these firms to reduce the amount of basic research they performed (see section 3.6.3). For pharmaceuticals, the decline in the concentration of basic research relative to innovation over the same period is probably due to the corporate mergers that occurred during the period studied.

This chapter makes several contributions to the literature on innovation. It presents the first estimates for the concentration of basic and applied research relative to innovation using a comparable methodology across industries. It introduces new bibliometric techniques for measuring scientific research. It presents a novel application of the Ellison-Glaeser index of relative concentration. And it extends the empirical literature on “absorptive capacity” beyond drug discovery.

In the next section, I discuss the relationship between a firm’s internal research and its innovation. Section 3.3 presents a methodology for measuring the concentration of research relative to innovation and Section 3.4 describes the data used. Section 3.5 presents the results, robustness checks, and the limitations of this study. Section 3.6 discusses the results; Section 3.7 concludes.

---

<sup>128</sup> “Basicness” is a relative concept. The theory of how transistors work is “basic” relative to its manufacture, but “applied” relative to quantum physics, which provides the scientific foundations for understanding how it works.

<sup>129</sup> Levin and Reiss (1988, Table 6) found that the semiconductor and pharmaceutical industries have among the highest elasticities of product and process R&D with respect to spillovers. Tilton (1971), Mowery (1983) and Appleyard (1996) describe the high level of spillovers in the semiconductor

### 3.2 The Economics of Scientific Research and Innovation

What determines the relationship between a firm's research effort and its ability to innovate? Notwithstanding empirical issues, there is evidence that a firm's research effort, when combined with conventional inputs, increases its productivity (Griliches, 1980; Hall, 1996). This is true not only for applied research, but for basic research as well (Griliches, 1986; Mansfield, 1981). According to Rosenberg (1990), a firm that performs basic research may benefit from first-mover advantage, unexpected innovations arising from the research, credibility in contests for government contracts, an improved ability to select areas of applied research, and an improved ability to evaluate the outcome of applied research.<sup>130</sup>

Despite the potential benefits, firms may be reluctant to invest in basic or applied research. This is because the knowledge produced by R&D is a public good (Nelson, 1959; Arrow 1962). Knowledge spills easily from innovating firms to other firms that can free ride on the efforts of the innovators. This problem is likely to be more serious for basic rather than applied research, as its anticipated appropriability is lower.<sup>131</sup> This concern led Vannevar Bush (1945) to advocate for government funding of basic research.

The public-goods nature of R&D complicates the relationship between a firm's R&D and innovative ability, since firms may also benefit from external research. Moreover, Cohen and Levinthal (1989, 1990) suggest that firms may need to invest in their own R&D to effectively absorb knowledge spillovers. This implies a positive

---

industry. Spillovers are also important for drug discovery (see Cockburn and Henderson, 1998, and the references therein).

<sup>130</sup> To this list, we might add the desire of firms to influence governments and consumers with respect to product safety or efficacy. For example, tobacco companies have spent millions of dollars on research to show that smoking is not harmful. Firms may also invest in R&D to gain goodwill or political capital.

<sup>131</sup> A firm's appropriability from innovation is also affected by its size and access to complementary assets (Levin, *et al.*, 1987; Teece, 1987).

interaction between a firm's own R&D and spillovers.<sup>132</sup> As described in the previous chapter (section 2.2), empirical research supports this hypothesis.

Unfortunately, the literature on absorptive capacity does not deal satisfactorily with the optimal mix among basic and applied research needed to capture spillovers. The question remains: how much basic (rather than applied) research must a firm perform to benefit from spillovers? Existing theories assume that *some* element of basic research is necessary. These theories are often based on the notion that knowledge is tacit and that one has to be involved in an activity to understand or exploit that knowledge (Nonaka, 1994; Leonard-Barton, 1995, chap. 6). Cohen and Levinthal (1990) speculate that “firms may conduct basic research less for particular results than to be able to provide themselves with the general background knowledge” that would help them exploit technological advances more effectively (1990, p. 148). Hence, “as a firm’s technological progress becomes more closely tied to advances in basic science (as has been the case in pharmaceuticals), a firm will increase its basic research, whatever its degree of product-market diversification”.<sup>133</sup>

Research on the pharmaceutical and biotechnology industries offers the best support for the view that firms must perform *basic* research to capture spillovers. Gambardella (1992) shows that pharmaceutical firms that perform basic research produce more patents.<sup>134</sup> He points out that “the winning models of the U.S. pharmaceutical industry during the 1980s were firms like Merck, which organized their internal research like academic departments” (1992, p. 404). Cockburn and Henderson (1998) found that drug discovery firms with a strong research orientation produced a greater number of important patents. Successful firms decentralized decision-making on the allocation of

---

<sup>132</sup> In contrast, Levin and Reiss (1988) do not assume that a firm’s research interacts with knowledge spillovers to increase productivity. They propose that if a firm’s own R&D and that of its rivals are strategic complements, an increase in spillovers might actually *increase* each firm’s R&D expenditure.

<sup>133</sup> Unfortunately, Cohen and Levinthal had no data on the composition of basic versus applied research for each firm, and so could not test their theory in its nuanced form.

<sup>134</sup> However, it is inconclusive from this study whether research-intensive firms produced more patents because they are better at capturing spillovers or because they have higher research productivity.

R&D resources and promoted scientists based on their publications in the open literature. Zucker and Darby (1995) reported that star<sup>135</sup> scientists had a large positive impact on the research productivity of biotechnology firms.

The close link between basic research and drug discovery arises because basic research allows a firm to hire high-quality researchers and to be “actively connected to the wider scientific community” (Cockburn and Henderson, 1998, p. 158). This raises the interesting question of whether membership into the scientific elite increases continuously with R&D expenditure, or whether it is the same for all firms who spend beyond a threshold amount on R&D (which represents a “membership fee”).

Outside the pharmaceutical and biotechnology industries, there are no conclusive studies showing that *basic* research helps firms capture spillovers. Indeed, the relationship between science and spillovers is highly complex, and varies across time and between technologies (Mowery and Rosenberg, 1989, pp.147). Anecdotal evidence exists in both directions, suggesting the need to explore this issue further. Whereas some companies, such as IBM, have a reputation for successfully exploiting basic research, others — including Apple, Sun, and Microsoft<sup>136</sup> — have been said to capture spillovers from competitors and academia without conducting much basic research.

### 3.3 Empirical Methodology

The discussion in the previous section can be summarized as an indication that a firm’s output of innovation,  $f_i()$ , depends *directly* on the productivity of its basic and applied research, and *indirectly* on knowledge spillovers through absorptive capacity. More formally:

$$\Pi_i = f_i(B_i, A_i, AbCap_i(B_i, A_i, X_i) * \mathbf{s}_{-i}) - C_i(B_i, A_i, X_i)$$

---

<sup>135</sup> “Star” scientists produce many papers, are highly cited, and collaborate heavily in public science.

<sup>136</sup> Sun capitalized on the RISC architecture developed by IBM and leading universities; Apple adapted the windows-based interface from Xerox PARC; in its early days, Microsoft developed the dominant PC operating system based on concepts developed at leading academic institutions. Each of these

where  $\Pi_i =$  firm  $i$ 's returns from innovation,  
 $f_i(.) =$  firm  $i$ 's innovative output,  
 $C_i(.) =$  firm  $i$ 's costs,  
 $B_i, A_i =$  firm  $i$ 's investment basic and applied research, which are functions of  $E(\Pi_i)$ ,  
 $X_i =$  firm  $i$ 's alternative instruments for developing absorptive capacity, (e.g. hiring newly graduated Ph.D.s, funding university research, co-authoring papers with academics, and inviting external researchers to join its scientific advisory board.)  
 $Abcap_i =$  firm  $i$ 's absorptive capacity, and  
 $\sigma_i =$  spillovers from outside firm  $i$ .

In this formulation,  $Abcap_i$  refers to a firm's ability to evaluate and internalize outside knowledge, while  $f_i(.)$  refers to its productivity in utilizing knowledge.<sup>137</sup> The main estimation problem here is that absorptive capacity ( $Abcap_i$ ) is inherently difficult for a researcher to observe or quantify. Likewise, spillovers are difficult to measure. Another problem is that a firm's investments in basic and applied research ( $B_i, A_i$ ) depend endogenously on anticipated benefits,  $E(\Pi_i)$ .

However, under special conditions stipulated below, it is possible to infer how absorptive capacity depends on basic and applied research by comparing the concentration of  $B_i$  and  $A_i$  with that of  $f_i$ .

Suppose we choose an industry with high spillovers ( $\sum \sigma_i \gg 0$ ), in which there is heterogeneity among firms in the benefits they anticipate from performing research. In such an industry, some firms would invest in basic and applied research as a means of acquiring absorptive capacity, while others would invest in alternative instruments,  $X_i$ . Suppose we observe that innovative output is concentrated in the firms that perform a great deal of basic research, which implies a positive relationship between basic research

---

companies performs little basic research. Only recently did Microsoft seriously begin to invest in basic research ("Software's Ultimate Sandbox", *Technology Review*, Jan-Feb 1999, pp. 44-51).

<sup>137</sup> Arora and Gambardella (1994) propose another model using similar concepts, and come up with interesting predictions for the number of projects a firm undertakes and its propensity to form strategic alliances.

and innovation. But we cannot distinguish whether this relationship is due to the direct productivity effect or the indirect effect of spillovers. The same reasoning applies for applied research. This equivalence among the observed variables is proven as Proposition 1 in Ellison and Glaeser (1997).

Now, consider the special case of a high-spillover industry in which many firms produce innovations, but *do not* perform much basic research (an analogous explanation holds for applied research). In this case, a possible reason why they do not perform much basic research is that doing so is not necessary for capturing spillovers. Of course, the alternative explanation is that firms which do not perform much research are not capturing spillovers, but rather are highly productive at translating internal research into innovations.<sup>138</sup> To minimize this likelihood, one must show that these firms are, in fact, capturing spillovers — which, in this thesis, is demonstrated by showing the widespread practice among these companies of co-authoring papers with researchers at universities and government laboratories.<sup>139</sup> Surely, knowledge is exchanged between co-authors in this process. In addition, other researchers have shown that the semiconductor and pharmaceutical industries exhibit high spillovers.<sup>140</sup>

Calculating the concentration of research relative to innovation should be seen as complementary to traditional regression analysis. Whereas performing a regression measures the strength of the relationship between innovation and research, this methodology focuses on the “off-diagonal” terms in the regression. It allows us to ask whether far fewer firms are investing in research than we would expect, given the amount of innovation produced by each firm.

---

<sup>138</sup> If  $(\sigma_i \gg 0)$  and most firms have low  $B_i$  but high  $f_i$ , this could mean that  $Abcap_i$  does not depend much on  $B_i$ , or that  $\partial f_i / \partial B_i$  is high.

<sup>139</sup> Co-authoring an article with academic institutions is not necessarily the same as performing basic research. Many academics also perform applied research, some of which is co-authored with industrial researchers.

<sup>140</sup> See footnote 129 for references to these studies.



### 3.3.1 Concentration Indices

I use several indices to compare the concentration of research to that of innovation. First, I use the Hirschman-Herfindahl index ( $H$ ) and the four-firm concentration ratio ( $C_4$ ).<sup>141</sup>

$$(1) \quad C_k = \sum_{i=1}^k s_i, \text{ and}$$

$$(2) \quad H = \sum_i s_i^2, \quad \text{where } s_i \text{ is firm } i\text{'s share of basic research, applied research or innovation.}$$

The Herfindahl and  $C_4$  indices are not the most appropriate for comparing the concentration of research to that of innovation, because *both* research activity and innovation are likely to be concentrated within large firms. The key issue is *whether research activity is concentrated relative to innovation*. Hence, the concentration index developed by Ellison and Glaeser (1997) is preferable, because it allows us to calculate  $g_l$ , the *excess concentration* of research relative to innovative output:

$$(3) \quad g_l \equiv \frac{\sum_j (s_{lj} - x_j)^2 - (1 - \sum_j x_j^2) \tilde{H}_l}{(1 - \sum_j x_j^2)(1 - \tilde{H}_l)},$$

where Research Area  $l \in \{\text{basic, applied}\}$

$s_{lj}$  = firm  $j$ 's share of research (publications) in area  $l$

$x_j$  = firm  $j$ 's share of innovation (patents).

$\tilde{H}_l$  = Herfindahl of research papers in area  $l$ .

Note:  $g_l$  takes on values between zero and one.

Imagine a map containing regions proportional to the size of each firm's innovative output. Now, imagine a person randomly throwing darts — each representing a basic research article — at the map. The Ellison and Glaeser index for basic research ( $g_B$ ) tells us whether basic research articles are more concentrated than we would expect from this random process. A similar map may be drawn for applied research to compute  $g_A$ .

---

<sup>141</sup> The properties of these and other indices are discussed in Curry and George (1983).

In their work on the geographic concentration of manufacturing, Ellison and Glaeser assume that in each industry  $l$ , firms choose to locate plant  $i$  in area  $j$ . The corresponding assumption is that firm  $j$  decides whether to publish research paper  $i$  in each research area  $l \in \{\text{basic or applied}\}$ . Table 3-1 summarizes the ways in which the Ellison-Glaeser model has been used in this paper and in Stern and Trajtenberg (1998).

**Table 3-1: Applications of the E-G Model**

Variable	Ellison-Glaeser (1997)	Stern-Trajtenberg (1998)	This Paper
$L$	Industry ( $l$ )	Physicians ( $l$ )	Research Area ( $l$ ) = {basic, applied}
$g_l$	Spillover parameter in industry $l$	Excess concentration of drug prescription by physician $l$	Excess concentration of research over innovation in area $l$
$J$	Area ( $j$ )	Drug ( $j$ )	Firm ( $j$ )
$X_j$	Share of total employment in area $j$	Share of drug $j$ in the market	Firm $j$ 's share of patents
$S_{lj} = \text{Sum}(z_{il}u_{ij})$	Share of employment of industry $l$ in area $j$	Share of drug $j$ among prescriptions by physician $l$	Firm $j$ 's share of research papers in area $l$
$i$	Firm/plant $i$ in industry $l$	Patient $i$ treated by physician $l$	Research paper $i$ in area $l$
$z_{il}$	Share of firm (plant) $i$ 's employment in industry $l$	Share of patient $i$ 's visits seen by physician $l$	Paper $i$ 's share of research in area $l$
$\tilde{H}_l = \sum_i^{N_l} z_{il}^2$	Herfindahl index of plant size in industry $l$	Herfindahl index of physicians ( $l$ ) in terms of their patients	Herfindahl index of research papers in area ( $l$ )
Analogy	In industry $l$ , each plant $i$ is located in area $j$ .	For physician $l$ , each patient $i$ is allocated to drug $j$ .	For research area $l$ (basic, applied), each research paper $i$ is "allocated" to firm $j$ .

Note:  $u_{ij}$  is an indicator variable set to 1 if research paper  $i$  is published by firm  $j$ .

The Ellison-Glaeser index overcomes spurious results that may arise if we simply compare Herfindahl indices,  $C_4$  ratios, or scatter-plots. It compares each firm's research and innovation *pair-wise*, because  $\mathbf{g}_l$  is a function of  $(s_{ij} - x_j)^2$ . Further, it accounts for the possibility that there may be too few articles in a given research area. For instance, it would be incorrect to conclude that a research area is more concentrated than innovation were there only a handful of articles in that research area, and the index corrects for this by including  $\tilde{H}_l$  into equation (3). Finally, the index accounts for the possibility that innovation may be concentrated in only a few firms by incorporating  $\sum_j x_j^2$  into the equation. Thus, if only two firms produced all the innovations in an industry,  $\sum_j x_j^2$  would be high. Conditional on the research level of each firm, this would cause  $\mathbf{g}_l$  to be high. The intuition is that it would be surprising to observe other firms performing research since only two are innovating.

A simpler version of the Ellison-Glaeser index can be used if a research area contains many articles. Define  $N_l$  to be the total number of scientific publications in research area  $l$  by all the firms. Article  $i$ 's share of research in area  $l$  is given by  $z_{il} = 1/N_l$ . Therefore,  $\tilde{H}_l = \sum_i^{N_l} z_{il}^2 = 1/N_l$ . If there are many papers in research area  $l$ , then  $\tilde{H}_l \rightarrow 0$ , and we obtain a simplified expression:

$$\text{As } N_l \rightarrow \infty, \mathbf{g}_l \rightarrow \frac{\sum_j (s_{lj} - x_j)^2}{(1 - \sum_j x_j^2)} \text{ (see Stern and Trajtenberg, 1998, footnote 11).}$$

In this case, the concentration of basic and applied research with respect to innovation are given by:

$$(4a) \quad \text{Basic research relative to innovation: } \mathbf{g}_B \rightarrow \frac{\sum_j (s_{Bj} - x_j)^2}{(1 - \sum_j x_j^2)}, \text{ and}$$

(4b) Applied research relative to innovation:  $g_A \rightarrow \frac{\sum_j (s_{Aj} - x_j)^2}{(1 - \sum_j x_j^2)}$

where  $s_{Aj}$  and  $s_{Bj}$  are firm  $j$ 's share of applied and basic research.

### 3.3.2 Measuring Basic Research, Applied Research and Innovation

In order to implement this methodology, it is necessary to measure the level of basic research, applied research, and innovation of each firm.

I measure each firm's innovative output as the number of patents it is awarded. There are limitations associated with using patent data to measure innovation (Griliches, 1990; Jaffe 1986). However, the empirical results are robust to the use of *cumulative net profits* rather than patents (at least for the American companies in the sample, for which *CompuStat* data were available).

I define the research output of each firm as the number of articles it publishes.<sup>142</sup> Each research article is classified as "basic" or "applied" based on the *journal in which the article is published*.<sup>143</sup> This makes the classification scheme tractable (as there are many more articles than there are journals). However, the price paid is the inability to capture heterogeneity among papers within each journal. Nonetheless, articles published in the same journal are circulated to the same community of scholars and, in most disciplines, there is specialization among journals. Thus, it is fairly easy to distinguish an applied journal oriented to solid-state engineers from a basic science journal aimed at quantum physicists.<sup>144</sup>

---

<sup>142</sup> For details on bibliometric measures of scientific output, see Stephan (1996, p. 1216) and Martin and Irvine (1983).

<sup>143</sup> Classifying research articles into basic and applied categories in this way does not provide a meaningful interpretation of the ratio of basic to applied papers for a given firm, since it is unclear how many "basic" papers are equivalent to each "applied" paper. However, it does allow for a comparison of the distribution of research papers *across firms* and in the same firm *across time*.

<sup>144</sup> Some journals are highly multidisciplinary and cover both basic and applied research (including *Nature*, and *Science*). Highly multidisciplinary journals are classified as "basic" because this adds a conservative bias against finding that basic research is concentrated.

While it may be preferable to measure basic and applied research using the composition of R&D expenditures, such data are not readily available.<sup>145</sup> The use of publication data rather than R&D expenditures has several advantages. Firstly they are more comparable across firms because papers submitted to the same journal go through the same peer-review process. Secondly, the data are publicly available, and thus are verifiable. And thirdly, they are available for privately owned companies, not just publicly traded ones.

## **3.4 Data**

This section discusses the construction of the dataset (subsection 3.4.1). It then describes the data on patents (subsection 3.4.2), publications (subsection 3.4.3) and co-authorship with academic and public-sector researchers (subsection 3.4.4).

### **3.4.1 Sample Construction**

The sample consists of patents and publications by all major semiconductor and pharmaceutical firms between 1985 and 1997<sup>146</sup> (see Appendix 3-A for a complete list of firms). The number of semiconductor firms in the sample each year ranges between 84 and 86, and between 30 and 36 for pharmaceutical firms (see Table 3-4). The year-to-year fluctuations are due to the entry and exit of firms, as well as mergers and acquisitions.

For semiconductors, a list of 297 firms was originally compiled from reports published by the Integrated Circuit Engineering (ICE) Corporation, Semiconductor Industry Association, *Electronics Business* and other sources. Seventy-three “fables”

---

<sup>145</sup> The NSF provides data on R&D expenditures at the level of each industry, but not the firm (see National Science Foundation, 1998). Several researchers have obtained firm-level data through surveys and interviews (e.g., Mansfield, 1981, and Ernst, 1998), but this is a costly process and subject to respondent bias.

<sup>146</sup> The year 1997 was chosen as a cut-off because the U.S. Patent Office takes several years to process each application.

semiconductor companies were eliminated because they do not manufacture their own semiconductor chips.<sup>147</sup> Another 135 companies with less than 15 publications per year and less than 100 patents between 1985 and 1995 were also dropped.<sup>148</sup> Six other companies were dropped because they compete primarily in other lines of business, but happen to operate semiconductor-manufacturing facilities (including these companies does not change the results).<sup>149</sup>

The pharmaceutical firms in the sample are those in Cockburn and Henderson (1998), plus four firms with significant numbers of publications or patents (BASF, Bayer, Astra-Zeneca, and DuPont).

For each industry, a list of major subsidiaries, mergers, and acquisitions was painstakingly constructed from public sources.<sup>150</sup> This list was used to combine the patents and publications of subsidiaries with the parent company.<sup>151</sup>

### 3.4.2 Data on Patenting Activity

The number of U.S. Patents awarded to each firm between 1985 and 1997 was obtained from the U.S. Patent Office. To restrict the analysis to innovations relevant to these industries, I include only patents awarded within the U.S. Patent Classes listed in

---

<sup>147</sup> According to the Fabless Semiconductor Association, “Fabless (without fab) refers to the business methodology of outsourcing the manufacturing of silicon wafers, which hundreds of semiconductor companies have adopted. Fabless companies focus on the design, development and marketing of their products and form alliances with silicon wafer manufacturers, or foundries.”

<sup>148</sup> Each of these firms represents less than 0.2% all publications and 0.1% of all patents during the time period, therefore contributing insignificantly to any concentration index.

<sup>149</sup> The six firms include four auto manufacturers (Honda, Nissan, Ford, Toyota) and two steel companies (Nippon Steel and Kawasaki Steel).

<sup>150</sup> Sources include annual reports, company websites, the *Directory of Corporate Affiliations*, *Hoover Company Profiles*, and analyst reports. I thank Celina Lee for helping me to compile these data for the pharmaceutical firms.

<sup>151</sup> Majority-owned subsidiaries and acquisitions are considered part of the parent company with effect from the year the transaction is completed. Merged companies are treated as new entities from the year the merger takes effect.

Table 3-2.<sup>152</sup> These patent classes were chosen with reference to USPTO Technology Profile Reports,<sup>153</sup> patent concordances, and by manually examining several hundred patents in each industry. Concentration indices depend on each firm's *share* of patents, and so it is more important for the patent classes to be representative than complete. In any case, the empirical results are robust to the inclusion of a broad range of patent classes (see section 3.5.2).

**Table 3-2: US Patent Classes Relevant to each Industry**

Semiconductors	Pharmaceuticals
156/345: Film Deposition	<i>424: Drug, bio-affecting and body treating compositions</i>
<i>257: Active Solid-State Devices (e.g., Transistors, Solid-State Diodes)</i>	435: Chemistry: molecular biology and microbiology
327: Miscellaneous Active Electrical Nonlinear Devices, Circuits, and Systems	436: Chemistry: Analytical and Immunological Testing
330: Amplifiers	<i>514: Drug, bio-affecting and body treating compositions</i>
331: Oscillators	530: Chemistry: natural resins or derivatives; peptides or proteins; lignins or reaction products thereof
365: Static Information Storage and Retrieval	585: Chemistry of hydrocarbon compounds
<i>438: Semiconductor Device Manufacturing: Process</i>	
711: Electrical Computers and Digital Processing Systems: Memory	

Note: The most important patent classes are shown in italics.

The semiconductor firms in the sample were awarded 47,224 relevant patents between 1985 and 1997 (see Table 3-4). Most fall within Patent Classes 438 (semiconductor device manufacturing) and 257 (active solid-state devices). These represent only one-fifth of the total number of patents awarded to semiconductor firms, because several companies were heavily involved in other lines of businesses (e.g., electronics, computers, telecommunications, and consumer products).

<sup>152</sup> Most patents fall into more than one Patent Classes. I include a patent in the sample if at least one of the Patent Classes it is assigned to lies within the relevant set.

<sup>153</sup> Technology Report TAF3290P covers Semiconductor Device and Manufacture. Report TAF3250P covers Drug, Bio-Affecting and Body Treating Compositions. For concordances, see <http://patents.cos.com/class/nest.shtml> and <http://metalab.unc.edu/patents/index/indexs1.html>.

During this period, the pharmaceutical firms in the sample received 18,438 relevant patents, mainly in Patent Classes 424 and 514 (drug, bio-affecting, and body treating compositions). This accounts for only 40% of the total patents awarded to these firms, since the firms also manufactured chemicals, personal-care products, drug-delivery systems, and hospital supplies.<sup>154</sup>

### 3.4.3 Data on Scientific Publications

Data on the scientific publications of each firm between 1985 and 1997 were obtained from the ISI Science Citation Index (SCI). The SCI is the best source of this information because it lists up to 255 authors and addresses for each publication.<sup>155,156</sup>

Another advantage of the SCI is its excellent coverage of basic scientific journals. Unfortunately, the SCI does not indicate which authors are associated with each address, and so I adopt the following convention: if one or more authors of an article lists a company as her address, I add one to the number of articles published by that company. For example, a paper written by three researchers from IBM and two from AT&T would increment the publication count *once* for IBM, and *once* for AT&T.<sup>157</sup> The rationale for this procedure is that each publication involves costly research as well as the opportunity cost of writing and revising the paper for publication.<sup>158</sup>

---

<sup>154</sup> Pharmaceutical firms were also awarded numerous patents for organic compounds (Patent Classes 532-570), but these were excluded from the analysis because many organic compounds are unrelated to pharmaceuticals (e.g., they are used for producing chemicals by BASF and Bayer). The inclusion of these patent classes does not qualitatively change the results.

<sup>155</sup> Source: personal communication with ISI staff. In the sample, each article by semiconductor firms had between 1 and 51 authors with a mean of 1.8. Each article by pharmaceutical firms had between 1 and 243 authors, with a mean of 2.3.

<sup>156</sup> Other databases (Compendex, INSPEC, and Biosis) only include the institutional affiliation of the first author for each article.

<sup>157</sup> Without each author's affiliation, it is impossible to weight each paper by the number of authors from each firm. Of more than 75,000 articles in each industry, only 1,032 semiconductor articles and 1,618 pharmaceutical articles were jointly authored by more than one of the firms in the sample.



**Table 3-3: Classification of Journal Categories into “Basic” and “Applied”**

JCR Journal Category	Semiconductor Industry	Pharmaceutical Industry
All Clinical Medical Journals	-U-	Applied
Biochemistry & Molecular Biology	-U-	<b>Basic</b>
Biology	-U-	<b>Basic</b>
Biophysics	-U-	<b>Basic</b>
Cell Biology	-U-	<b>Basic</b>
Chemistry, Analytical	Applied	Applied
Chemistry, Applied	Applied	Applied
Chemistry, Inorganic & Nuclear	Applied	-U-
Chemistry, Medicinal	-U-	Applied
Chemistry, Organic	-U-	Applied
Chemistry, Physical	<b>Basic</b>	-U-
Chemistry	<b>Basic</b>	-U-
Engineering (Electrical, Chemical & Nuclear)	Applied	-U-
Genetics and Hereditary	-U-	<b>Basic</b>
Material Science	Applied	-U-
Mathematics, Applied	Applied	-U-
Mathematics, Misc.	Applied	-U-
Mathematics	<b>Basic</b>	-U-
Medicine, General & Internal	-U-	Applied
Medicine, Research & Experimental	-U-	<b>Basic</b>
Microbiology	-U-	<b>Basic</b>
Multidisciplinary Science	<b>Basic</b>	<b>Basic</b>
Physics, Applied	Applied	-U-
Physics, Atomic, Molecular & Chem	<b>Basic</b>	-U-
Physics, Condensate Matter	<b>Basic</b>	-U-
Physics, Mathematical	<b>Basic</b>	-U-
Physics, Misc.	Applied	-U-
Physics, Nuclear	Applied	-U-
Physics, Particles & Fields	Applied	-U-
Physics	<b>Basic</b>	-U-
... Other categories		

Notes: -U- indicates an unrelated field.

Categories not shown are either Applied or Unrelated.

As with patents, I chose sets of relevant journals for each industry. I built upon the journal classification scheme published with the SCI, known as “JCR categories.” I classified some of these as “basic” and others as “applied” (see Table 3-3). For pharmaceuticals, “basic” JCR categories include biochemistry, molecular biology, and

---

<sup>158</sup> In applying this procedure, only *original research articles* were included. I excluded meeting notes, review articles, book reviews, editorials, and so on.

genetics; for semiconductors, these categories include pure physics, mathematics, and chemistry. Each article was analyzed and the variable **JCRBas** set to 1 if it were published in a basic JCR category. Appendix 3-B shows that the empirical results are robust to other classification schemes.

To map companies to research articles, I searched each article's address field for the company name or address. Special care was taken when dealing with university laboratories having the same names as these companies.<sup>159</sup> Accidentally including them can potentially distort the results because universities are a major locus of basic research. These laboratories were identified correctly by searching the web pages of the universities and companies involved and by contacting them where necessary. In the small number of cases where uncertainty could not be resolved, the observation was dropped.

As shown in Table 3-4, the semiconductor companies in the sample published 77,417 relevant research articles between 1985 and 1997, of which 20% were classified as basic research. The pharmaceutical companies published 75,507 relevant research articles, of which 25% were basic. The number of basic and applied research articles is large in both industries, and hence I used the simplified formulae for  $g_i$  (Equations 4a, 4b).

### **3.4.4 Data on Co-authorship with Academic Researchers**

I identified co-authorship between industry and academic researchers by searching the author affiliation field of each article for keywords such as “Univ,” “Inst,” and

---

<sup>159</sup> Several of these laboratories are owned by companies but located on university campuses (e.g., Lilly Laboratory at Indiana University). Others are named after family trust funds unrelated to the business (Wellcome, DuPont). A handful are the addresses of individuals who have joint appointments at universities and these firms, while others are simply names of buildings (e.g., the Searle building at the University of Chicago).

“Ecole.”<sup>160</sup> An indicator variable, **CoAu**, was set to 1 if an article is co-authored between a firm and an academic institution. A broader measure, **CoAuAll**, also included government laboratories, government ministries, medical centers, and hospitals. Roughly one-third of the articles published by semiconductor firms and half published by pharmaceutical firms were co-authored with academics or public-sector researchers (see Table 3-4).

**Table 3-4: Summary Statistics (all firms, 1985-1997)**

<b>Data Item</b>	<b>Semiconductors</b>	<b>Pharmaceuticals</b>
No. of firms in the sample per year	84 to 86	30 to 36
<b>Patents</b>		
Total No. of U.S. patents awarded to these firms	232,684	47,713
No. of U.S. patents awarded to these firms in relevant patent classes	47,224	18,438
<b>Scientific Publications</b>		
No. of research articles by firms in the sample (all journals)	91,831 articles in 2053 journals	86,073 articles in 2721 journals
No. of research articles by firms in the sample (relevant journals only)	77,417 articles in 803 journals	75,507 articles in 1815 journals
<b>Basic Research and Co-authorship*</b>		
No. of basic research articles by these firms in relevant journals, i.e., <b>JCRbas = 1</b>	15,665 articles (20%)	18,945 articles (25%)
No. of articles co-authored With academic institutions ( <b>CoAu = 1</b> )	25,782 articles (33%)	38,219 articles (51%)
With Public Sector Researchers ( <b>CoAuAll=1</b> )	27,304 articles (35%)	42,289 articles (57%)

\* The numbers in parentheses are the numbers of articles expressed as a proportion of the total number of research articles in relevant journals.

<sup>160</sup> The Science Citation Index adheres to standard keywords, so “University” is always abbreviated as “Univ.” The keywords occurring most frequently were derived by manually coding every article published by these companies in 1985 and 1995. These keywords were then used to generate the **CoAu** and **CoAuAll** measures of each article for the remaining years.

**Table 3-5: Descriptive Statistics**

Variable (per firm per year)	Avg	Std. Dev.	Min	Max
<b>Semiconductors</b>				
No. of Patents	46	73	0	420
No. of Basic Research Articles (JCRBas=1)	17	60	0	510
No. of Applied Research Articles (JCRBas=0)	66	141	0	918
No. of Articles Co-authored with public-science (CoAuAll=1)	29	73	0	624
<b>Pharmaceuticals</b>				
No. of Patents	43	38	0	236
No. of Basic Research Articles (JCRBas=1)	35	45	0	270
No. of Applied Research Articles (JCRBas=0)	105	105	0	582
No. of Articles Co-authored with public-science (CoAuAll=1)	79	90	0	574

### 3.5 Results

Descriptive statistics are shown in Table 3-5. The relationship among these variables is summarized by a regression analysis of patent output versus basic and applied research (see Tables 3-6 and 3-7). As shown in Table 3-6, the coefficient for applied research is positive in both industries, while that for basic research is negative for semiconductors and insignificant for pharmaceuticals. This provides *suggestive* evidence that (1) applied research is more closely associated with innovation than basic research; and (2) basic research is more closely connected to innovation in the pharmaceutical industry than the semiconductor industry. The same qualitative findings emerge when the analysis is repeated using firm fixed-effects (Table 3-7).

**Table 3-6: OLS (dependent variable is the number of patents per firm per year)**

<b>LHS Variable</b>	<b>Semiconductors (N=930)</b>	<b>Pharmaceuticals (N=431)</b>
No. of Basic Research Articles (JCRBas=1)	-0.32* (0.07)	-0.01 (0.09)
No. of Applied Research Articles (JCRBAS=0)	0.37* (0.03)	0.18* (0.04)
Year	4.2* (0.5)	1.3* (0.45)
Adj. R-squared	0.29	0.28

Note: Standard errors are shown in parentheses.

**Table 3-7: OLS with Firm Fixed Effects (dependent variable is number of patents per firm per year)**

<b>LHS Variable</b>	<b>Semiconductors (N=930)</b>	<b>Pharmaceuticals (N=431)</b>
No. of Basic Research Articles (JCRBas=1)	-0.71* (0.12)	-0.69 (0.07)
No. of Applied Research Articles (JCRBAS=0)	0.46* (0.06)	0.18* (0.04)
Year	4.9* (0.3)	1.7* (0.32)
Firm fixed effects	Significant	Significant
Adj. R-squared	0.79	0.80

Note: Standard errors are shown in parentheses.

### 3.5.1 Main Results

The scatter-plots in Figures 3-1 and 3-2 provide some intuition for the main results. In the semiconductor industry, a surprising number of companies appear close to the vertical axis (Figure 3-1). Many companies, such as Motorola, Fujitsu, and Texas Instruments, perform little basic research but produce many patents. In contrast, there appears to be a closer relationship between patents and basic research in the pharmaceutical industry (Figure 3-2).

Figures 3-3 and 3-4 show the  $C_4$  Index of basic research, applied research, and patents. In any given year, the top four semiconductor firms accounted for 60-80% of all basic research, but produced only about 30% of the patents. By comparison, the top four pharmaceutical firms accounted for only 30-50% of basic research and roughly the same proportion of patents. Interestingly, the concentration of basic research declined in both industries between 1985 and 1997, as discussed in section 3.6.3. Using the Herfindahl Index rather than the  $C_4$  ratio produces similar results (see Figures 3-5, 3-6).

In both industries, applied research is less concentrated than basic research.<sup>161</sup> In the case of semiconductors, applied research is more concentrated than patents, while for pharmaceuticals it borders on being less concentrated.

Figures 3-7 and 3-8 show the Herfindahl Index for co-authorship with academic scientists. In both industries, the practice of co-authoring research articles with outside researchers is less concentrated than basic research and close to that of applied research. In fact, it is as widespread as all research publications taken together. This suggests that firms are indeed capturing spillovers from academic institutions and public-sector laboratories.<sup>162</sup>

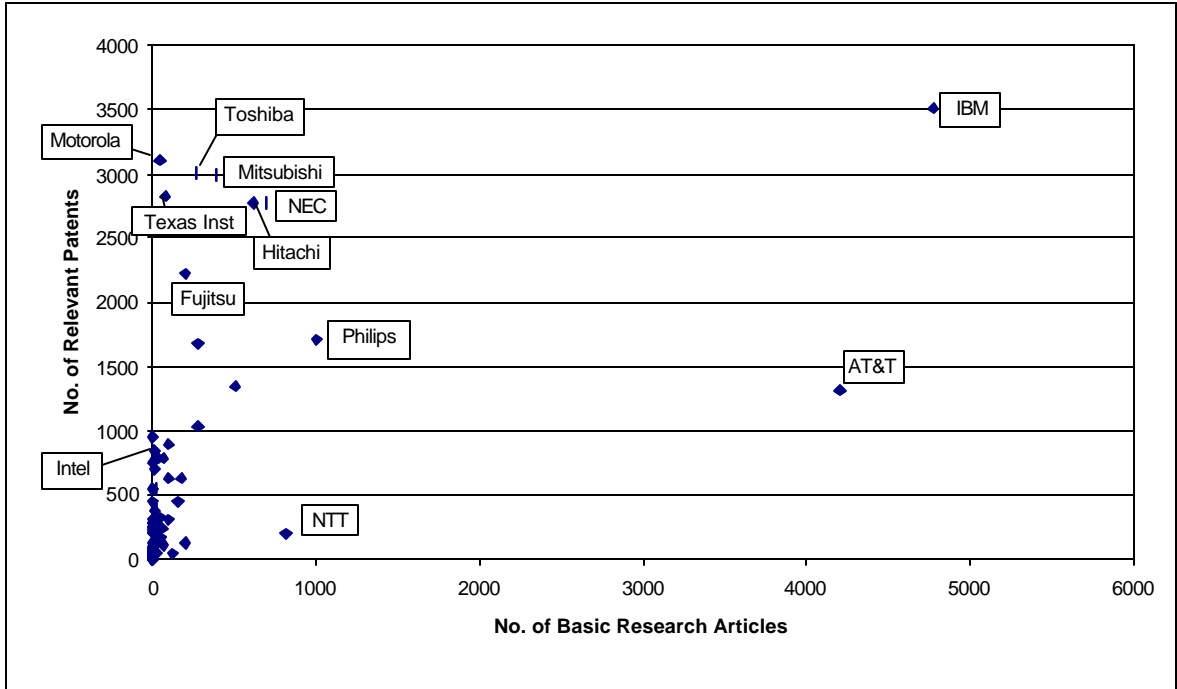
The results persist if we use the more carefully constructed Ellison-Glaeser indices (see Figures 3-9 and 3-10). I computed the E-G index for several hypothetical scenarios

---

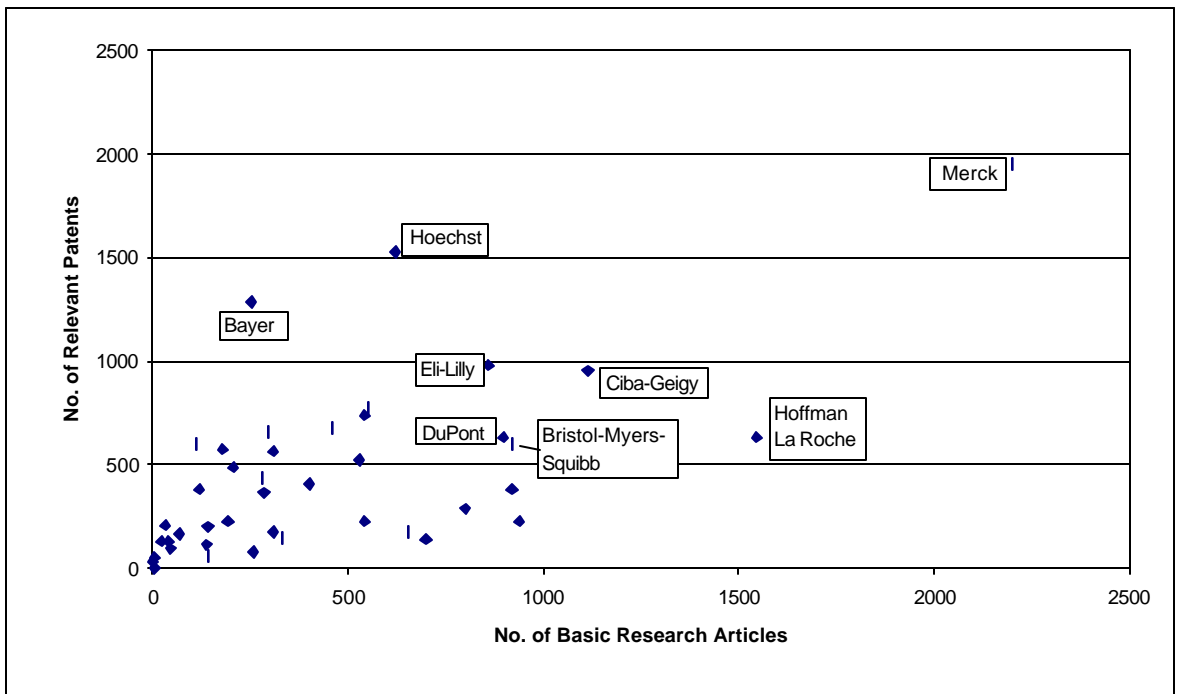
<sup>161</sup> This result holds whether we use the  $C_4$  index (see Figure 3-3 and 3-4) or the Herfindahl Index (see Figure 3-5 and 3-6).

<sup>162</sup> Co-authorship with academic institutions ( $\mathbf{CoAu}=1$ ) is highly widespread, so the addition of other public-sector research organizations ( $\mathbf{CoAuAll}=1$ ) does not change the results. As it has little effect,  $\mathbf{CoAuAll}$  was dropped in subsequent analysis.

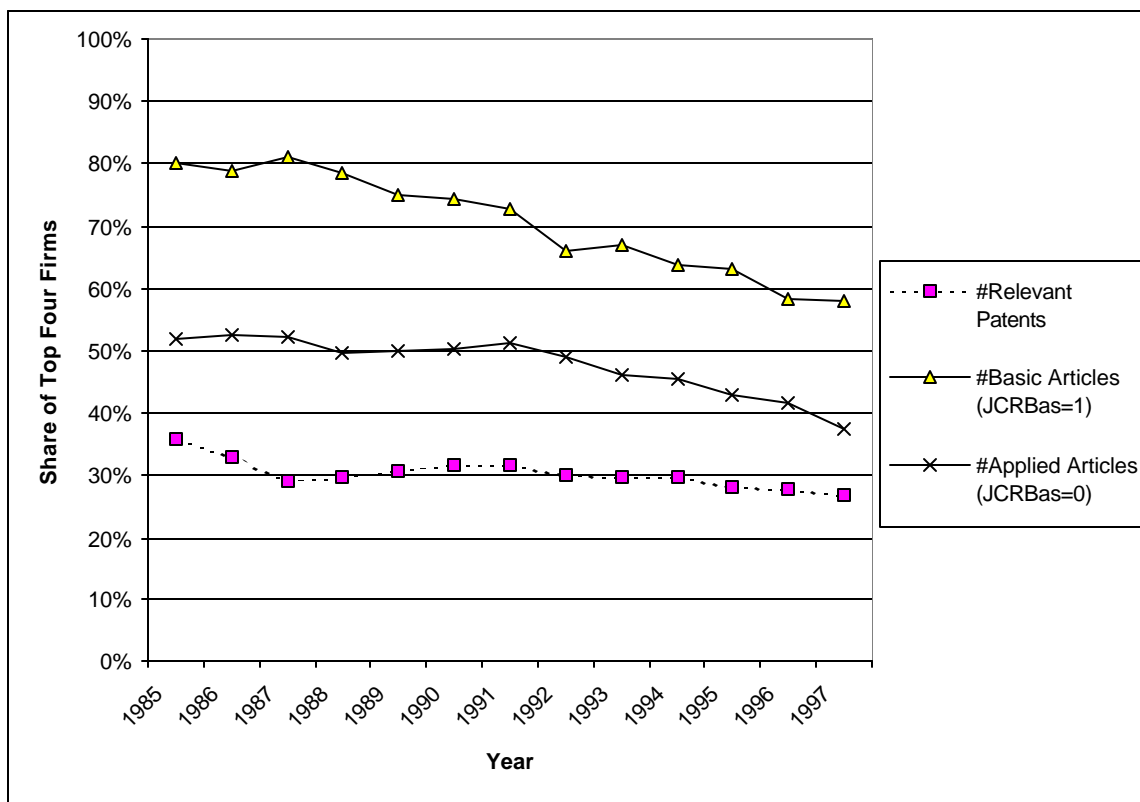
**Figure 3-1: Semiconductor Firms- Number of Relevant Patents versus Number of Basic Research Articles (1985-1997)**



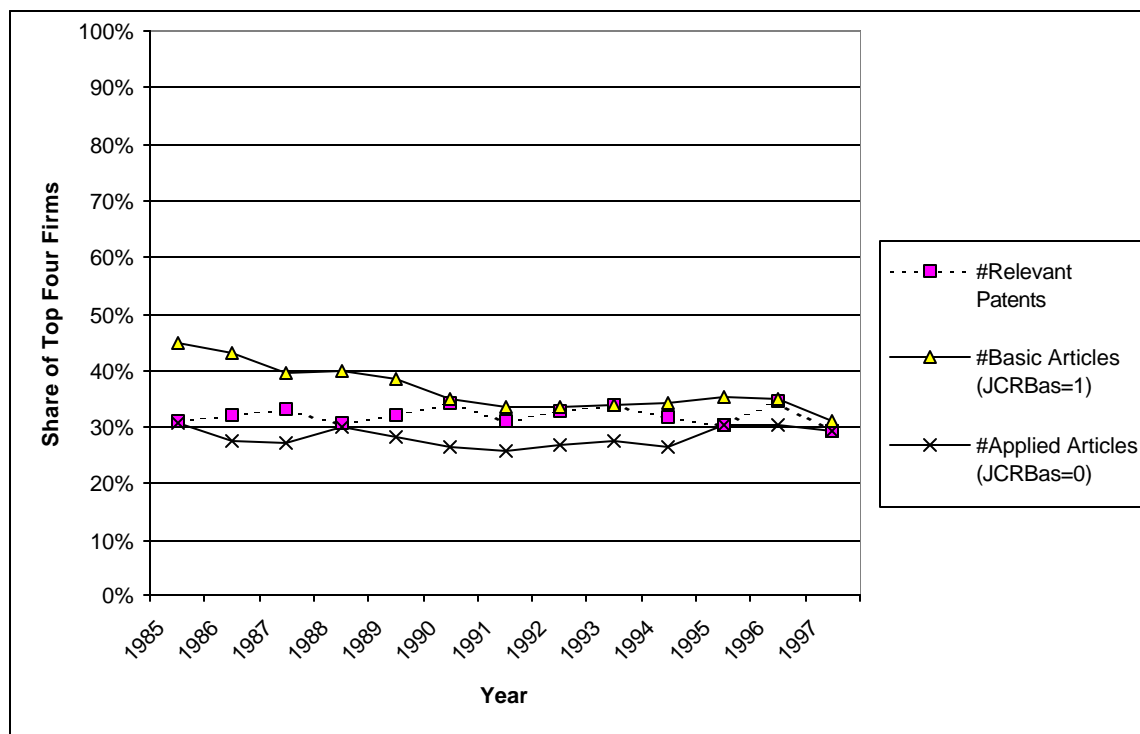
**Figure 3-2: Pharmaceutical Firms- Number of Relevant Patents versus Number of Basic Research Articles (1985-1997)**



**Figure 3-3: Semiconductor Firms- C4 Index of Basic Research, Applied Research and Innovation**

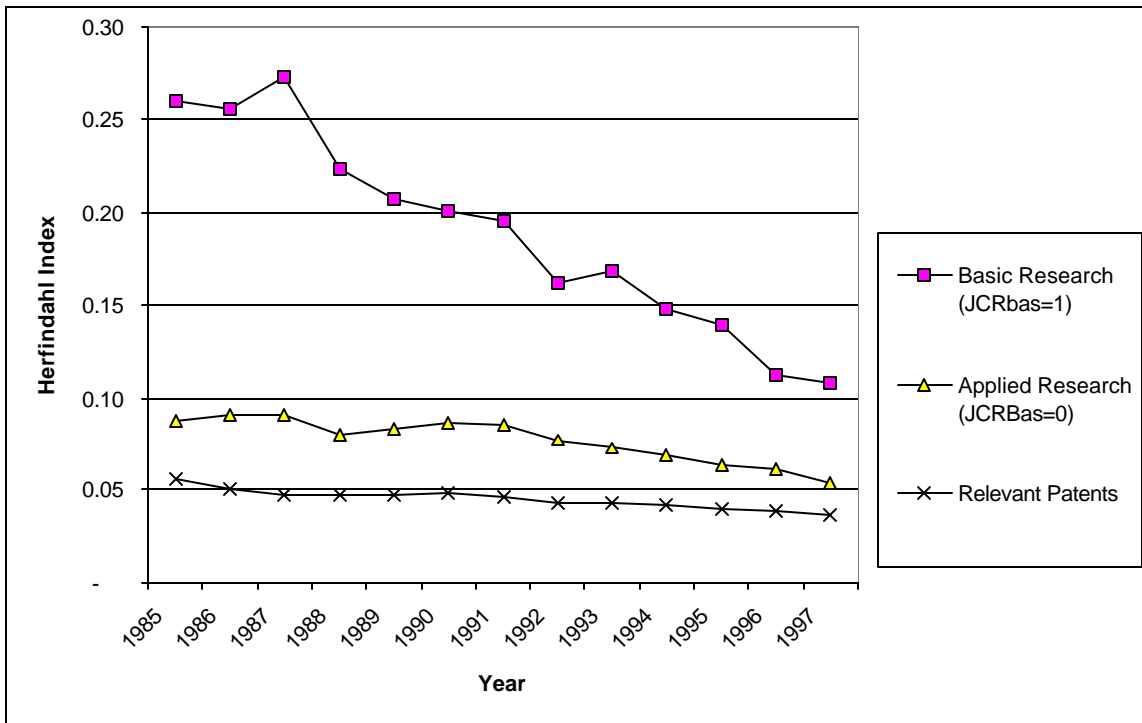


**Figure 3-4: Pharmaceutical Firms- C4 Index of Basic Research, Applied Research and Innovation**

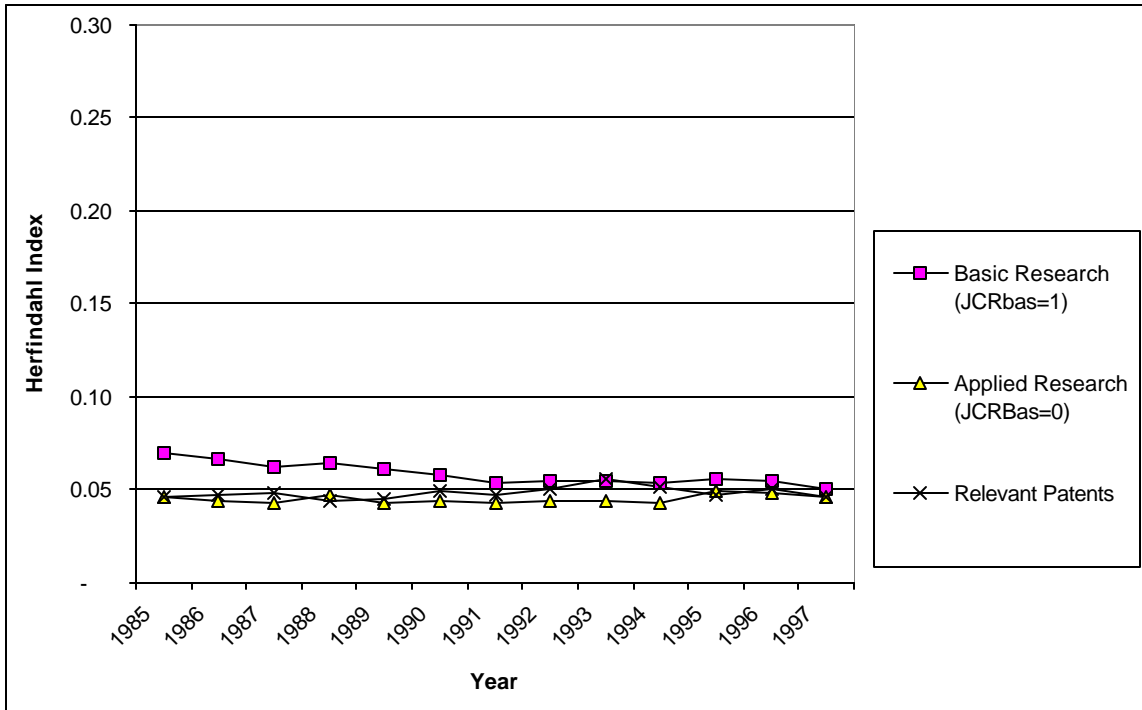




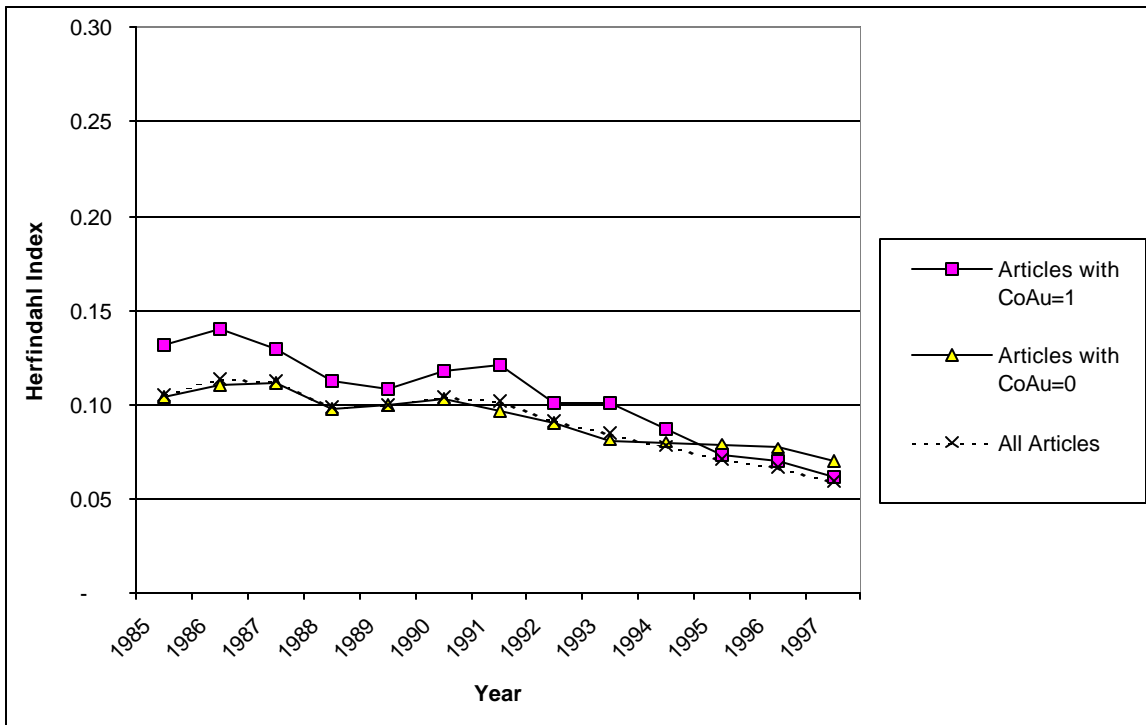
**Figure 3-5: Semiconductor Firms- Herfindahl Index of Basic Research, Applied Research and Innovation**



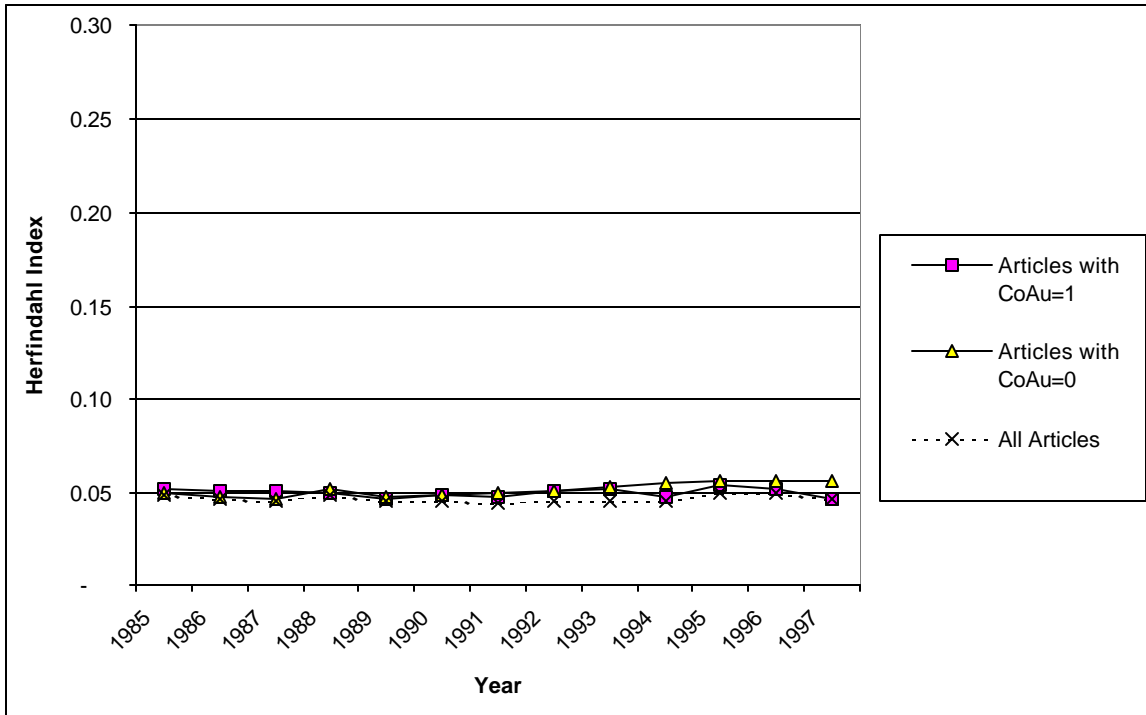
**Figure 3-6: Pharmaceutical Firms- Herfindahl Index of Basic Research, Applied Research and Innovation**



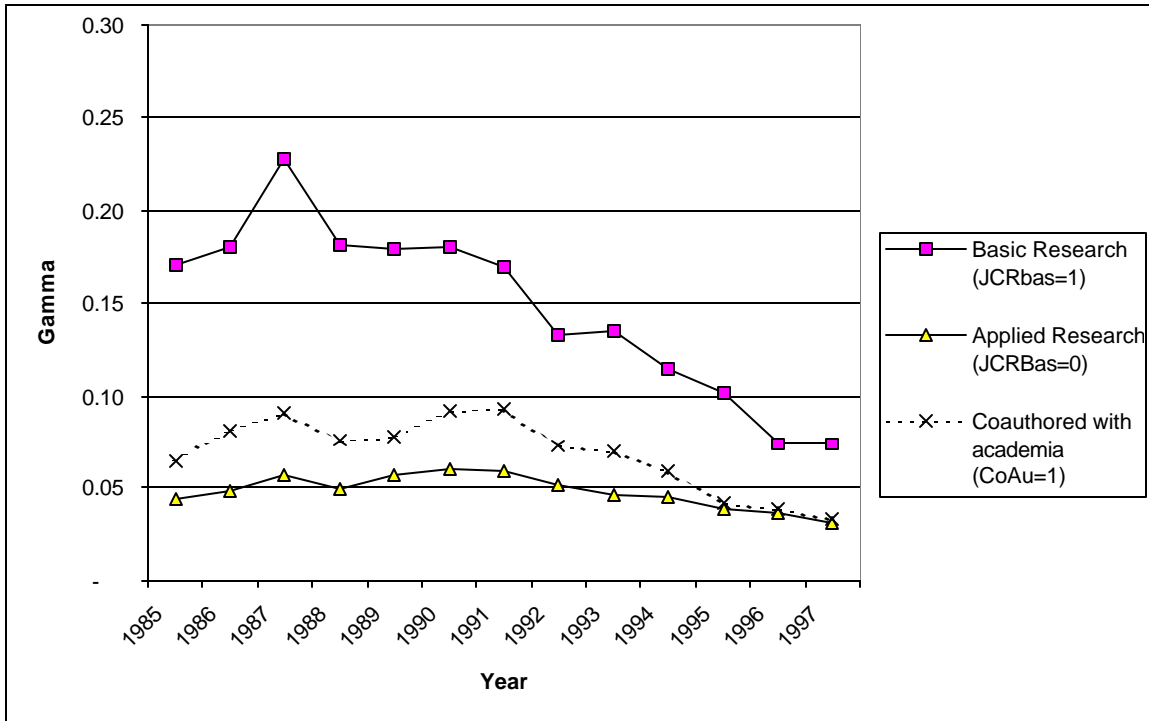
**Figure 3-7: Semiconductor Firms- Herfindahl Index of Articles Co-authored with Academic Researchers**



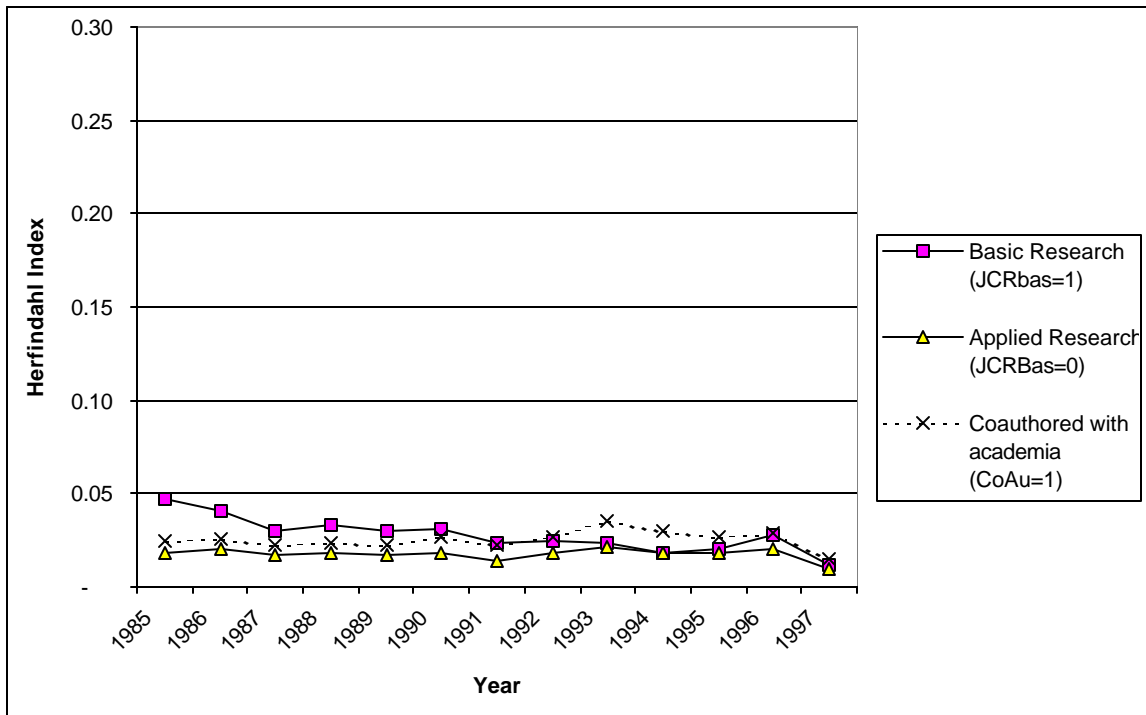
**Figure 3-8: Pharmaceutical Firms- Herfindahl Index of Articles Co-authored with Academic Researchers**



**Figure 3-9: Semiconductor Firms- Gamma for Basic Research and Applied Research Relative to Innovation**



**Figure 3-10: Pharmaceutical Firms- Gamma for Basic Research and Applied Research Relative to Innovation**



**Table 3-8: Hypothetical Scenarios: Gamma Relative to the Number of Relevant Patents (1985-1997)**

	<b>Scenario</b>	<b>Gamma (Semiconductors)</b>	<b>Gamma (Pharmaceuticals)</b>
<b>Actual</b>	Actual number of basic research articles (JCRBas=1) between 1985 and 1997	0.13	0.02
	Actual number of basic research articles (JCRBas=1) in 1990	0.17	0.03
	Actual number of applied research articles (JCRBas=0) between 1985 and 1997	0.04	0.01
	Actual number of articles co-authored with academic researchers (CoAu=1) between 1985 and 1997	0.05	0.02
<b>Scenario</b>	Basic research split equally among the top 3 firms	0.29	0.26
	Basic research split equally among the top 4 firms	0.23	0.21
	Basic research split equally among the top 5 firms	0.17	0.16
	Basic research split equally among the top 6 firms	0.12	0.13
	Basic research split equally among the top 10 firms	0.06	0.07
	Basic research uniformly divided among all firms in the sample	0.03	0.02

Note: In each case, Gamma was calculated with respect to the actual number of patents awarded to each firm between 1985 and 1997.

to provide meaningful interpretations of the results (see Table 3-8).<sup>163</sup> For various scenarios,  $g_i$  was calculated relative to the actual number of relevant patents awarded to each firm between 1985 and 1997. For semiconductors, the concentration of basic

---

<sup>163</sup> These are not “simulations” because actual distributions are used for innovation output.

research relative to innovation is around 0.13, which is similar to the scenario in which it is *only performed by the top 5 or 6 firms*. For pharmaceuticals, however, the concentration of basic research relative to innovation is around 0.02, which is no different than the scenario in which it is *uniformly distributed* among firms. In both industries, applied research and co-authorship with academic researchers have similar concentrations to the scenario in which they are uniformly spread out across firms.

### 3.5.2 Robustness Tests

For the semiconductor industry, there is a legitimate concern that the omission of irrelevant patent classes may be driving the results. In other words, the top firms may have received “too few” semiconductor patents relative to basic research because their basic research led to patents in other areas. It turns out, though, that the results are extremely robust to the inclusion of a broad range of patent classes. Even if we include patents from *every patent class* awarded to each firm, the concentration of basic research relative to innovation remains practically unchanged ( $g_B = 0.14$  for all basic research articles relative to all patents between 1985 and 1997).

Another concern is that patent counts may not be a satisfactory measure of innovation. The value of patents is highly skewed (Trajtenberg, 1990; Harhoff, Scherer and Vopel, 1997). Also, some semiconductor firms may have obtained patents not because they were producing real innovations but in order to engage in barter (Hall and Ham, 1999). Future research may explore the use of patent citation data to see if this explanation is borne out. Nonetheless, for patenting activity to be at least as concentrated as basic research in the semiconductor industry, the average patent by the top performers of basic research (IBM, AT&T, and Philips) would have to be *five times* more heavily cited than other firms. This would cause Gamma to fall below 0.05.

Instead of patent counts, I use the *cumulative net profit* of each firm as an alternative measure of innovation performance. Data from *CompuStat* were available for 47 major U.S. firms in the sample. For these firms, the Herfindahl Indices of basic

research, patents, and cumulative net profits were 0.43, 0.09, and 0.14, respectively. The concentration of basic research relative to relevant patents is  $g_B=0.33$ , and that of basic research relative to cumulative net profits is  $\gamma = 0.31$ . Hence, basic research is highly concentrated relative to cumulative net profits in the semiconductor industry. The reason is straightforward: almost all of the basic research among U.S. semiconductor companies during the period examined was done by IBM and AT&T, while the largest profits were made by Intel, followed by IBM, AT&T, Hewlett Packard, and Motorola.

Appendix 3-B explores the robustness of these results to different interpretations of what constitutes “basic” research and expands the variables to include “highly academic” research. The results are essentially unchanged if we count research articles published in journals with high *basic science scores* assigned by CHI Research,<sup>164</sup> those published in highly cited journals, or those published in journals with a large number of academic authors.

I performed an additional test for the pharmaceutical industry to explore the possibility that basic research is not concentrated in this industry because our definition is overly generous and hence many “applied” journals are inadvertently included. I calculated  $g_B$  using only articles published between 1985 and 1997 in three leading journals (*Nature*, *Science*, and *Cell*). This yields a value of  $g_B=0.07$ , which is not particularly high compared to the hypothetical scenarios shown in Table 6. It appears safe to conclude, therefore, that basic pharmaceutical research is indeed not concentrated relative to innovation.

### 3.5.3 Limitations

A key limitation of this study is that I do not explicitly show a causal link between spillovers from co-authored papers and innovation output. It remains possible that while many semiconductor firms co-author articles with academic researchers, their patents

---

<sup>164</sup> CHI Research is a private company that specializes in evaluating the quality of intellectual property.

grow from internal R&D efforts unrelated to the knowledge they acquire from the co-authoring activities. Further research is needed to validate the assumption that spillovers occurred through co-authorship.

Another limitation of the study is that by comparing patents and publications contemporaneously, I disregard the time lag between research and innovation. Previous work has shown a high variance in the time before basic research comes to fruition (e.g., Adams, 1990). Unfortunately, I have no basis for guessing what kinds of lags and depreciation rates are appropriate for each paper and patent in the sample.

A third limitation of this study is the inclusion of U.S. patents only. Omitting European and Japanese patents may bias the sample. Fortunately, this risk is low because the United States is the largest market for both semiconductor and pharmaceutical products, so important European and Japanese patents are also filed in this country.

A fourth limitation is that the SCI is biased towards English-language publications. Nevertheless, the results persist when all non-U.S. firms are dropped from the sample.

Despite the limitations, there emerges a robust empirical regularity in which basic research is highly concentrated relative to innovation in the semiconductor industry. In the next section, I provide an interpretation of the results, propose an analytical framework for understanding the relationship between research and innovation, and examine changes in the concentration of basic research over time.

### **3.6 Discussion**

One interpretation of the results is that most semiconductor firms do not perform much basic research, but are able to capture spillovers. Performing basic research is not the only way a firm can remain connected. Firms may also co-author papers with academic and public-sector researchers, fund research at universities, and invite outside

scholars to join their scientific advisory boards. Several interviewees emphasized the importance of hiring “fresh” Ph.D.s from leading academic institutions. Some of these Ph.D.s perform basic research (e.g., at IBM and AT&T), but many bring a wealth of scientific knowledge to the firm and are assigned to work on the early stages of development projects.

Historical accounts point to the mobility of labor, rather than internal basic research, as the key driver of spillovers in the semiconductor industry (Tilton, 1971; Wilson, 1980). For example, William Shockley, one of the three inventors of the transistor, left Bell Laboratories to form his own company. Subsequently, key personnel left Shockley’s company to form Fairchild Semiconductors, which spawned Intel Corporation and much of the Silicon Valley (Riordan and Hoddeson, 1997).

Intel — arguably the most successful semiconductor firm in recent history — eschews research laboratories. The firm spends heavily on development but performs little basic research, exploiting knowledge spillovers by investing in *external* research at universities and research consortia (Moore, 1996, pp. 170). These relationships are carefully managed by the Intel Research Council, which carefully regulates funding and matches researchers at Intel with outside scientists. According to Intel co-founder Gordon Moore, “We don’t have a separate R&D laboratory ... the development work is done right on the manufacturing floor” (Jelinek and Schoonhoven, 1990, p. 295).

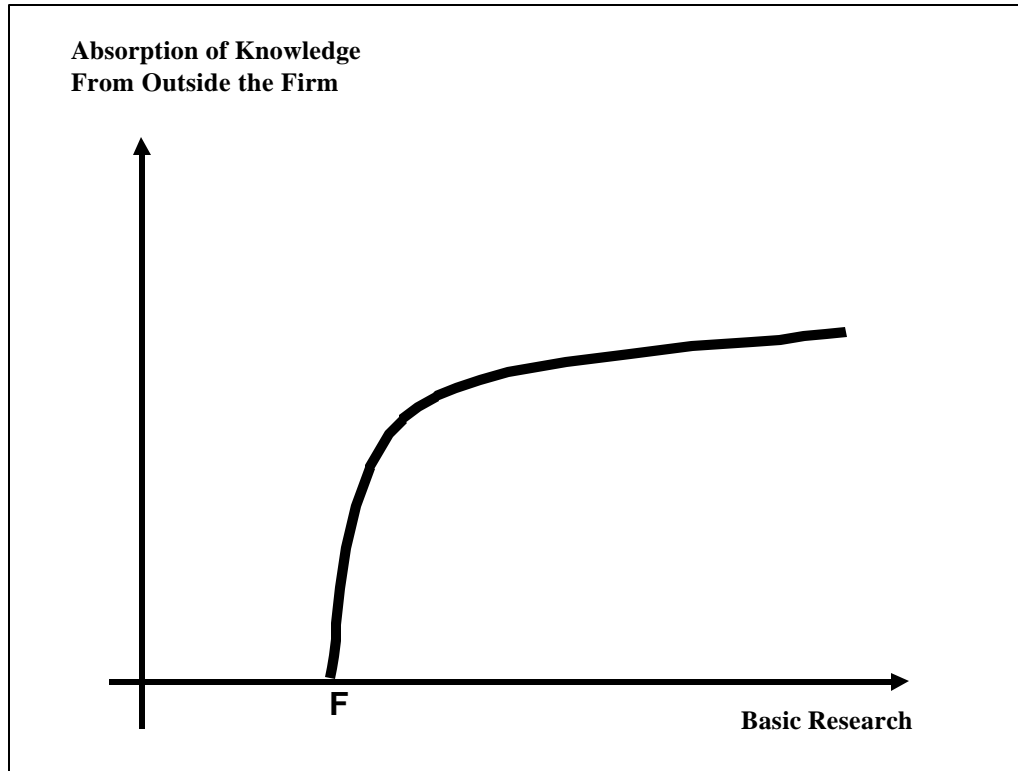
### **3.6.1 An Analytical Framework**

How is it possible for semiconductor firms to capture spillovers without performing much basic research? I speculate that the relationship between a firm’s basic research and its ability to absorb external knowledge is non-linear (see Figure 3-11). A firm may perform some basic research (**F**) to gain membership in the external network of scholars, as well as to attract talented employees. But conditional on obtaining membership, additional basic research may not greatly improve a firm’s absorptive capacity. This is



because a small number of people within a given organization — known as “gatekeepers” or “boundary spanners” (Allen, 1977; Rothwell and Robertson, 1973; Zucker and Darby, 1995) — play an inordinate role in absorbing external information. These individuals keep up with external knowledge and convey it into the internal language of the organization. By relying on only a few key individuals to span the realm of outside knowledge, a firm reduces the number of redundant contacts it needs to maintain, thereby creating a sparse network that is more efficient (Granovetter, 1973; Burt, 1992).

**Figure 3-11: Hypothesized Relationship between a Firm’s Basic Research and its Absorption of External Research**



This non-linear aggregation of individual effort causes the relationship between a firm’s basic research and its ability to keep up with external knowledge to saturate. The threshold level, **F**, varies by industry, depending on the structure of knowledge and the effectiveness of alternative means for acquiring outside knowledge.

In contrast to basic research, a firm's ability to benefit from external knowledge should increase more gradually with *applied* research. While academics and public-sector researchers have incentives to publish and share their work, private firms have stronger reasons to conceal information in order to benefit from that information. Hence, while basic ideas may diffuse easily, the information needed to translate them into products and services may not spillover as freely. Each firm has to experiment and reverse-engineer competitors' products to replicate such knowledge. These constitute development activities rather than basic research.

Closely related is that applied research is more difficult to codify than basic research,<sup>165</sup> which makes it easier to conceal such information. This also makes it more efficient to rely on "strong ties" rather than "weak ties" for communicating applied research (Hansen, 1999).<sup>166</sup> Absorptive capacity may increase more gradually with applied research as well because external information is used most heavily in the initial stages of R&D projects, while subsequent product and process development depends largely on internal knowledge (Utterback, 1971). Thus, absorptive capacity may increase over a fairly large range of applied R&D, but mainly for exploiting the knowledge rather than for acquiring the knowledge from outside the firm.

If this explanation is true, why should *any* firm invest in substantial amounts of basic research? There are several possible explanations. First, the alternatives to basic research may also be costly (such as Intel's approach of funding university research, or paying higher salaries to attract high-quality talent). Second, some firms may have higher expected benefits or hold complementary assets that help them to appropriate the returns of basic research. Third, firms that perform more basic research may be

---

<sup>165</sup> In other words, applied research is more "sticky" than basic research, as defined by von Hippel (1994). Once discovered, fundamental concepts explaining how transistors work or how to splice genes are relatively easy to convey. However, the techniques involved may require many steps and a great deal of tacit knowledge.

<sup>166</sup> Hansen (1999) finds that strong ties between organizational units are more effective when knowledge is highly complex and tacit, while weak ties are better when knowledge is easily codified. This

attempting to capture types of spillovers that are different than those sought by firms that make less of an investment. For example, these firms may be hiring discipline-oriented researchers rather than those with domain-specific knowledge. Further work is required to investigate these possibilities and their implications for productivity.

### **3.6.2 Semiconductors versus Pharmaceuticals**

While basic research is much more concentrated than patents in the semiconductor industry, it mirrors the distribution of patents rather closely in the pharmaceutical industry. This implies a closer relationship between *basic* research and patents in the pharmaceutical industry than semiconductors.

One explanation for this pattern is that a higher threshold exists for pharmaceuticals than for semiconductors, so pharmaceutical firms must invest a higher level of basic research to gain membership into the external network of researchers. This could be due to the presence of fewer research collaborations in pharmaceutical industry than in the semiconductor industry (e.g. the Semiconductor Research Corporation and Sematech).

The alternative explanation is that pharmaceutical firms perform basic research in excess of the level needed simply to absorb external knowledge. Perhaps the expected benefits are higher: medical research is the prototypical case of basic research that seeks a fundamental understanding of phenomena and yet is motivated by practical goals (Stokes, 1997). It is likely that pharmaceutical firms are willing to invest in useful research, even if it is considered fundamental. In addition, the appropriability of basic research may be higher in the pharmaceutical industry than in the semiconductor industry. This may be due to the longer product lifecycle for pharmaceuticals and a stronger regulatory regime.

---

resonates with my argument if we accept that basic research is more easily codified than applied research.

As discussed in section 3.3, the methodology used in this chapter does not allow us to distinguish between these two explanations. It does, however, demonstrate a distinct difference between the two industries (one requiring further exploration).

### 3.6.3 Changes In the Concentration of Basic Research Over Time

In both the semiconductor and pharmaceutical industries, the concentration of basic research declined between 1985 and 1997. For semiconductors, the  $C_4$  ratio for basic research dropped substantially from 80% in 1985 to 58% in 1997 (Figure 3-3), while for pharmaceuticals it fell more gradually from 45% to 31% (Figure 3-4).

One reason for this decline may be that basic research became *increasingly* important, and so attracted investment from a greater number of companies. But the opposite may also be true: that basic research became *less* important, and so the leading companies reduced their investments.

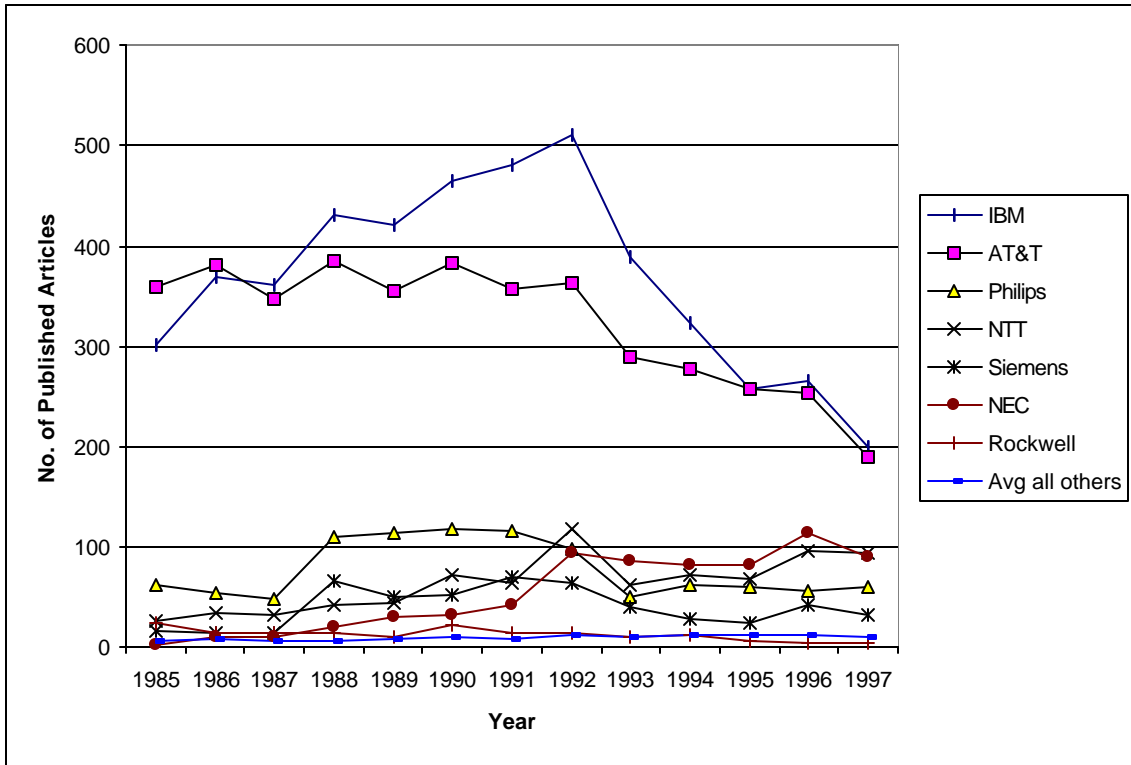
The first explanation appears to be true for pharmaceuticals, while the latter appears true for semiconductors. This is supported by the data in Figures 3-12 and 3-13, which show the number of basic research articles published by leading semiconductor and pharmaceutical firms.

IBM, which led basic research for semiconductors, faced financial difficulties in the early 1990s and drastically reoriented its R&D organization towards applied science and development.<sup>167</sup> It slashed by more than half the number of basic research articles it published between 1991 and 1997 (see Figure 3-12). Similarly, AT&T faced the end of a

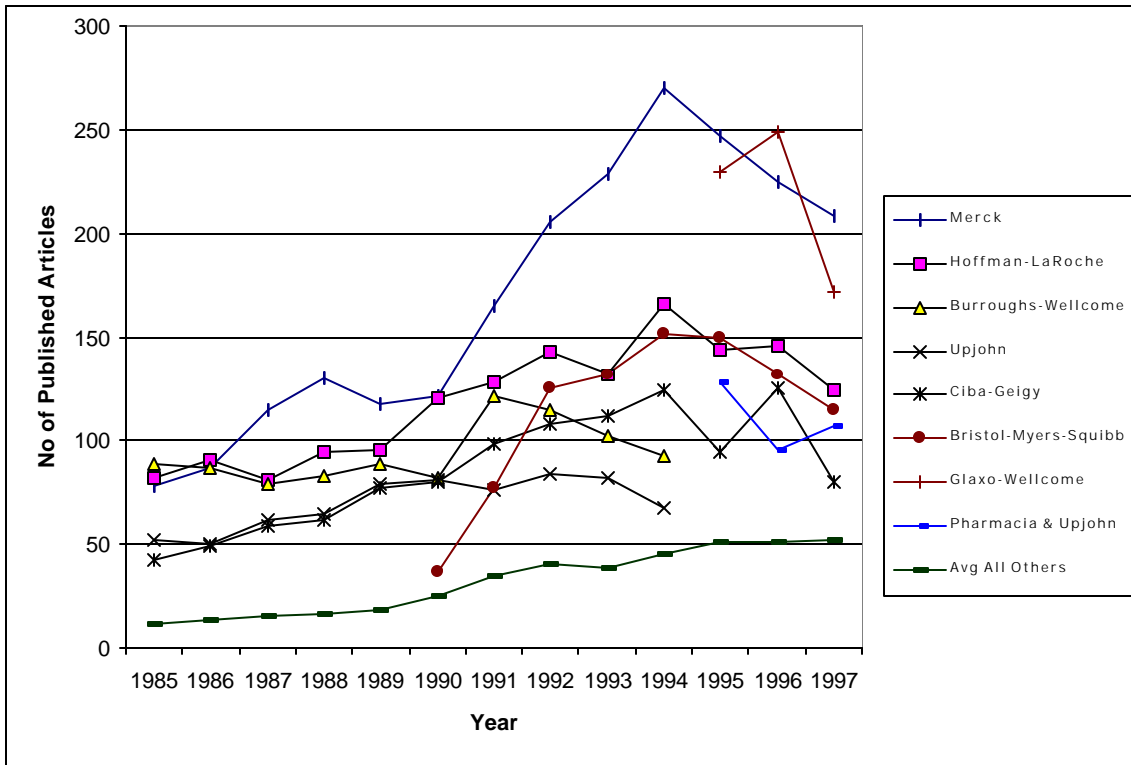
---

<sup>167</sup> “In 1992, when newly appointed chairman Louis Gerstner began downsizing IBM, the research division was included and saw its budget cut by a third, from \$6.5 billion in 1992 to a low of \$4.3 billion in 1994. It has since bounced back to \$6 billion in 1995 as more of its work became product oriented ...” (“IBM Reconnects Research,” *Electronics Business Today*, Sept. 1996). See also “Into the Big Blue Yonder,” *Technology Review*, 1999, 102(4) 46-53; and “R&D Gets Real,” *Electronic Business Today*, Oct. 1997.

**Figure 3-12: Top Semiconductor Firms- Number of Articles in Journals with JCRbas=1**



**Figure 3-13: Top Pharmaceutical Firms- Number of Articles in Journals with JCRbas=1**



long monopoly and reoriented Bell Laboratories, which was eventually spun off as part of Lucent Technologies.<sup>168</sup> Thus, in the semiconductor industry, basic research may have been a luxury afforded by past success, rather than a prerequisite for capturing spillovers.

In the pharmaceutical industry, the advent of rational drug design in the early 1990s may have triggered the increase in basic research at Merck and Roche (see Figure 3-13). Smaller competitors took a different path, merging in two large waves in the late 1980s and mid-1990s. Some of the entities thus created had a significant number of basic research publications, including Glaxo-Wellcome, Pharmacia-Upjohn, and Bristol-Myers-Squibb. Therefore, the concentration of basic research declined slightly, despite Merck's massive buildup.

The time-trend for pharmaceuticals reveals two other interesting points. One, basic research was relatively widespread in the pharmaceutical industry even before the advent of rational drug discovery. So, while rational drug design may have boosted its importance, basic research was already significant. Two, Merck's basic research output fell when it faced financial difficulties around 1993,<sup>169</sup> echoing the events at IBM and AT&T. Additional analysis reveals that the company's number of applied research publications climbed unabated during this difficult period at Merck.

Finally, the time-series makes it unlikely that the difference between pharmaceuticals and semiconductors arose simply because the semiconductor industry is more "mature," so that most firms innovate without depending on external knowledge. On the contrary, basic research was even more concentrated in the past than it is today. As early as 1985, many semiconductor firms innovated without performing much basic

---

<sup>168</sup> In "Lucent's Ascend," *BusinessWeek*, February 8, 1999, the firm's CEO describes how he linked Bell Lab's research budget directly to revenue growth.

<sup>169</sup> According Merck's 1994 Annual Report, net income fell by 11% in 1993, after which the company took a \$775 million restructuring charge and eliminated 2,100 jobs.

research.<sup>170</sup> Another reason to doubt this claim is that most drugs being produced today are still being made the old-fashioned way — that is, not through rational drug design.

### 3.7 Conclusion

This chapter’s main contribution is a careful measurement of the concentration of basic and applied research relative to innovation in the semiconductor and pharmaceutical industries. Basic research is found to be highly concentrated relative to innovation in the semiconductor industry, but not in the pharmaceutical industry. In both industries, the practice of co-authoring papers with academic researchers is widespread, implying that firms are able to capture spillovers. I interpret this to mean that (at least in the semiconductor industry) many firms are able to capture spillovers without performing a great deal of basic research. In both industries, the concentration of applied research closely matches that of innovation output. The results are robust to the use of alternative definitions for “basic” research, the inclusion of various patent classes, and the use of net profits rather than patent counts to measure performance.

These empirical regularities raise many exciting questions. How effective are the alternative modes used by firms to capture spillovers, when used with and without internal basic research? Why do some semiconductor firms perform more basic research than expected? And why do so many pharmaceutical firms perform basic research? The results here also strongly suggest that we need to consider more carefully what it means to capture spillovers, whether there are different types of spillovers, and how the process of absorbing external information actually unfolds.

---

<sup>170</sup> Each process generation in semiconductors is approximately two years, so 1985 was at least seven generations ago.

### Appendix 3-A: List of Firms in the Sample

Semiconductors		Pharmaceuticals
Acer Labs, Inc.	LSI Logic	Abbott
Actel Corporation	Macronix	American Home Products
Advanced Micro Devices (AMD)	Matsushita Electric Corporation	Astra
Alcatel	Microchip Technology	BASF
Altera	Micron Semiconductor Inc. (subsidiary of Micron Technology)	Bayer
American Microsystems, Inc.	Mitel Semiconductor	Beecham
Analog Devices	Mitsubishi Electric Corporation	Bristol-Myers
Asahi Kasei Microsystems	Mostel-Vitelec	Bristol-Myers-Squibb
AT&T (Lucent)	Motorola, Inc. (Semiconductor Products Sector)	Burroughs-Wellcome
Atmel Corporation	National Semiconductor Corp.	Ciba-Geigy
Brooktree Corporation	NCR Microelectronic Products	DuPont
Burr-Brown	NEC Corporation	ELAN
Canon, Inc.	Newport Wafer Fab Limited	Fujisawa
C-Cube	Northern Telecom (Nortel)	Glaxo
Chartered Semiconductor Manufacturing	Northrop & Northrop Grumman Corp	Glaxo-Wellcome
Cherry Semiconductor Corp	NTT(Nippon Telephone & Telegraph)	Hoechst (&Roussel)
Cirrus Logic	Oki Electric industry Co., Ltd.	Hoffman-LaRoche
Cray Computer	Philips	Johnson & Johnson
Cray Research, Inc.	Raytheon Semiconductor Division	Eli Lilly
Cypress Semiconductor, Inc	Ricoh Co., Ltd.; Electronic Device Division	Marion
Cyrix Corporation	Rockwell International	Marion-Merrell-Dow
Daewoo Electronic Components Co.	Rohm Co., Ltd.	Merck
Dallas Semiconductor	S3 Inc.	Merrell-Dow
Digital Equipment Corporation (DEC - Now Compaq)	Samsung Electronics Company	Procter & Gamble Pharmaceuticals
Ericsson Components A.B.	Sanyo Electric Co.	Pfizer (& Roerig)
ESS Technology	Seiko Epson Corp.	Pharmacia
Fuji Electric Co., Ltd.	Sharp Corporation	Pharmacia & Upjohn
Fujitsu	Siemens	Rhone-Poulenc
GEC-Plessey (acquired by Mitel)	Sony Corporation	Rorer
General Semiconductor	ST Microelectronics (SGS-Thomson)	Sandoz
Grumman (pre1994)	Symbios	Sankyo
Harris Semiconductor	Taiwan Semiconductor Manufacturing Co., Ltd.	Schering (German)
Hewlett-Packard Company	Tech Semiconductor Singapore Pte. Ltd.	Schering-Plough (USA)
Hitachi	Temic (Bought by Vishay; IC div sold to Atmel)	Searle (Monsanto owns it)
Honeywell, Inc., Solid State Electronics Center	Texas Instruments	Smithkline
Hughes Aircraft Company (merged with Raytheon)	Toshiba	Smithkline-Beecham
Hyundai Electronic Industries Co., Ltd., Semiconductor Division	United Microelectronics Corporation (UMC)	Squibb
IBM	United Technologies Microelectronics Center	Takeda
Integrated Device Technology (IDT)	VLSI Technology, Inc.	Upjohn
Intel Corporation	Weitek	Warner-Lambert
International Rectifier	Westinghouse, Advanced Technology	Yamanouchi
ITT Semiconductors (ITT Industries)	Winbond	Zeneca
Lattice Semiconductor	Xilinx	
LG Semicon (Lucky-Goldstar)	Yamaha Corporation	
Linear Technology Corporation	Zilog, Inc.	



### Appendix 3-B: Robustness of the Results to Journal Classification Schemes

In this Appendix, I explore the robustness of the results to alternative ways of classifying journals. Four classification schemes are implemented using the indicator variables **JCRbas**, **CHibas**, **HiSCI** and **HiAcad**. The first two variables attempt to measure “basic” research as that which seeks a fundamental of phenomena. The third and fourth variables expand beyond basic research to look more generally at highly cited research and the types of research typically performed at academic institutions. Summary statistics of these four variables are shown in Table 3-9.

**Table 3-9: Descriptive Statistics of Journal-Level Variables (all journals in the SCI, 1985-1997)**

Variable	N	Min	Max	Avg	StdDev	Percentiles		
						25%	50%	75%
<b>SCI85</b>	3421	0	39.7	1.27	1.85	0.41	0.79	1.5
<b>SCI93</b>	1367	0	37.2	1.44	2.08	0.46	0.93	1.7
<b>SCI97</b>	3826	0	40.8	1.51	2.44	0.46	0.91	1.7
<b>Acad85</b>	3205	0	1	0.79	0.19	0.73	0.84	0.92
<b>Acad90</b>	3043	0	1	0.82	0.16	0.77	0.86	0.93
<b>Acad95</b>	3274	0	1	0.84	0.15	0.80	0.88	0.93
<b>Acad97</b>	3293	0	1	0.85	0.14	0.80	0.88	0.93
<b>JCRBas</b>	4901	0	1	0.18	0.38	NA	NA	NA
<b>CHIBas</b>	4901	0	4	2.75	1.15	2	3	4

Note: Numerical suffixes represent the year. For example, SCI85 is the Science Citation Index Impact factor for each journal in 1985.

The first variable, **JCRBas**, is defined on page 106. The second variable, **CHIBas**, uses the classification scheme developed by CHI Research, Inc. CHI awards each journal a score from zero to four. For the physical sciences, levels 1 through 4 correspond to applied technology, engineering sciences, applied research, and basic research,

respectively. For the biomedical sciences, they correspond to clinical observation, clinical mix, clinical investigation and basic science (see Hicks, 1996, for more details). In this thesis, I define a research article as “basic” if it is published in a journal with **CHibas** = 4.

The third variable, **HiSCI**, identifies research articles that are published in highly cited journals. It is based on each journal’s **SCI** Impact Factor (**SCI**), which is published in the Journal Citation Reports that accompany each year’s edition of the *Science Citation Index*.<sup>171</sup> The **SCI** Impact Factor for journal *k* in year *y* is given by:

$$(5) \quad SCI_{ky} \equiv \frac{\text{No of citations in year } y \text{ to articles published in journal } k \text{ in years } (y-1) \text{ and } (y-2)}{\text{No of articles in journal } k \text{ in years } (y-1) \text{ and } (y-2)}$$

As shown in Table 3-9, the distribution of **SCI** is highly skewed. A small number of journals have high impact scores, reaching up to 40.8. However, 75% of the journals in a given year have impact scores less than 1.7. This is consistent with the bibliographic literature on Zipf’s Law and Bradford’s Law, which states that only a small set of core journals in a scientific discipline are highly cited (Garfield, 1980). I define a journal to be *highly cited* if it falls within the top 25% of this distribution, specifically those with **SCI** Impact Factor scores exceeding 1.7.

$$\text{In year } yy, \text{ define } HiSCI_{yy} \equiv \begin{cases} 1 & \text{if } SCI_{yy} > 1.7 \\ 0 & \text{otherwise} \end{cases}$$

The fourth variable, **HiAcad**, identifies research that is similar to academic research. It locates articles that are published in journals with a large percentage of academic authors. Such journals are often heavily circulated among academics, and their editorial boards are dominated by academics. **HiAcad** is based on each journal’s **Acad** score, which is the percentage of papers in that journal with one or more academic

authors. Each journal's **Acad** score is derived by searching the address fields of every article in the SCI for keywords such as "university," "school" and "ecole".<sup>172</sup>

The construction of the **Acad** and **HiAcad** variables is a novel contribution of this thesis and may have other applications. As shown in Table 3-9, most journals have a high percentage of papers with one or more academic authors. The twenty-fifth percentile of **Acad** is around 80%, so in three-quarters of the journals, at least 80% of the articles include an academic author. I define a journal to be *highly academic* if it is in the top quartile in its **Acad** score. This corresponds to having at least 93% of the papers in the journal written by at least one academic author.

$$(6b) \quad \text{In year } yy, \text{ define } HiAcad_{yy} \equiv \begin{cases} 1 & \text{if } Acad_{yy} > 93\% \\ 0 & \text{otherwise} \end{cases}$$

Table 3-10 shows the correlation between **HiSCI**, **HiAcad**, **JCRBas** and **CHIBas**.<sup>173</sup> As expected, the correlation between variables is low because they measure different things. What is important is the high correlation *across years* for **HiSCI** and **HiAcad**. This implies that a journal's importance and academic orientation remained fairly stable between 1985 and 1997. I therefore use **HiSCI97** and **HiAcad97** to measure basicness.

Despite the low correlation between the various measures of basic research, the results are remarkably consistent. Figures 3-14 and 3-15 show the E-G Gamma for basic research and co-authorship relative to patents (other results are available upon request). Further analysis shows that the results are also robust to changing the cutoff values of **HiSCI** and **HiAcad**. Hence, the results are robust over a wide range of definitions for basic research.

---

<sup>171</sup> ISI does not publish the **SCI** scores for every journal each year, but all the major ones are included.

<sup>172</sup> Not all journals have **Acad** scores for any given year, since some journals changed their names, merged with other journals, or were discontinued.

**Table 3-10: Correlation for Various Measures of Basic Research (all journals in the SCI, 1985-1997)**

	HiSCI85	HiSCI93	HiSCI97	HiAcad85	HiAcad90	HiAcad95	HiAcad97	JCRBas	CHIBas
HiSCI85	1.00								
HiSCI93	0.73*	1.00							
HiSCI97	0.68*	0.75*	1.00						
HiAcad85	0.01	0.01	0.00	1.00					
HiAcad90	0.01	0.01	0.03	0.56*	1.00				
HiAcad95	0.01	0.01	0.01	0.52*	0.54*	1.00			
HiAcad97	0.03	0.00	0.01	0.49*	0.51*	0.55*	1.00		
JCRBas	0.14*	0.15*	0.11*	0.21*	0.20*	0.20*	0.22*	1.00	
CHIBas	0.18*	0.28*	0.16*	0.31*	0.27*	0.24*	0.24*	0.36*	1.00

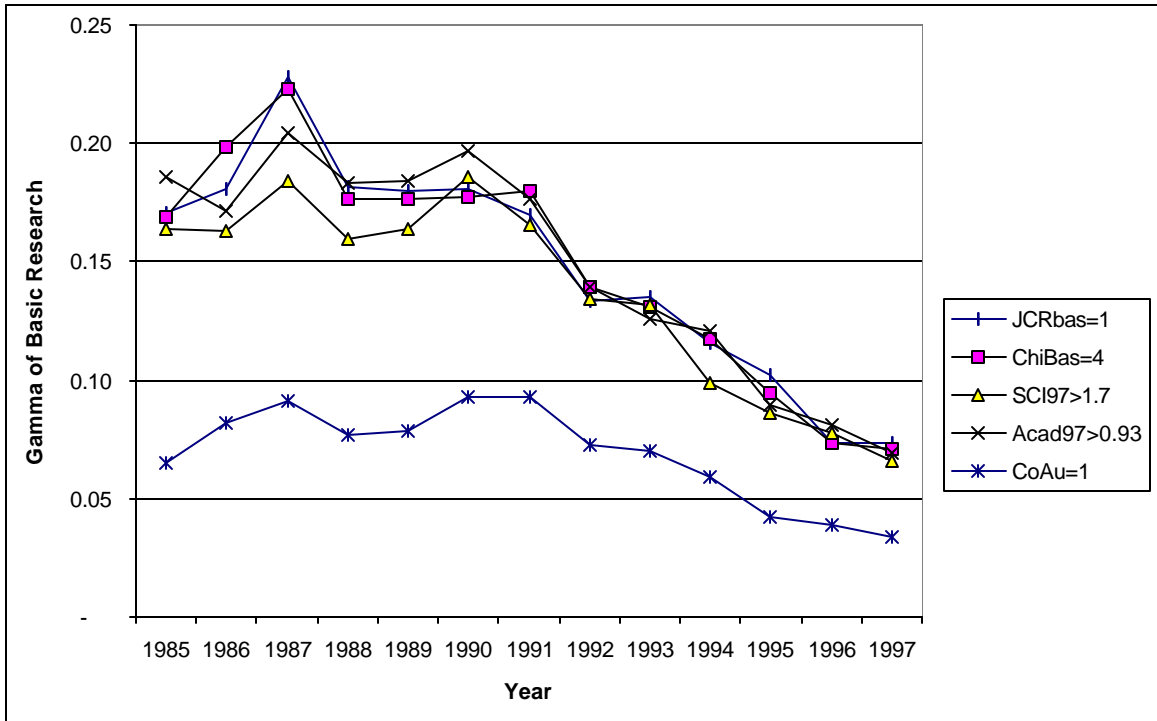
Notes: \*= significant at the 5% level.

The results are similar for journals relevant to semiconductors or pharmaceuticals.

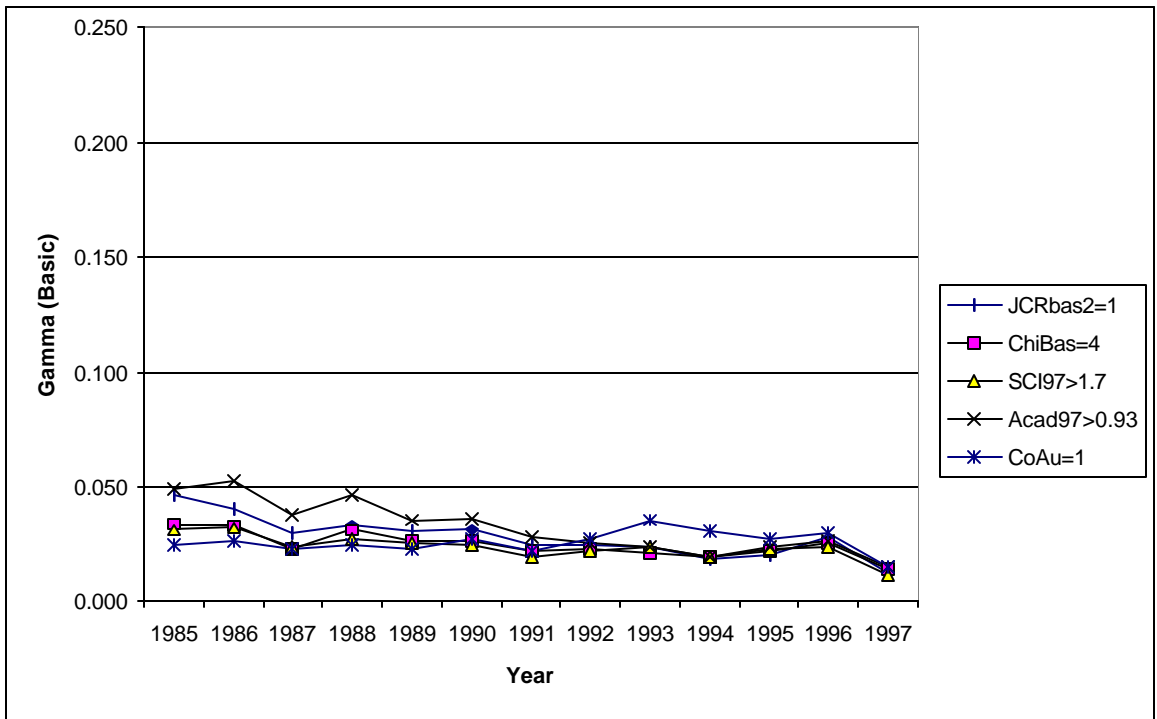
---

<sup>173</sup> The correlation coefficients remain similar for the subsets of journals relevant to semiconductors and pharmaceuticals.

**Figure 3-14: Semiconductor Firms- Gamma of Number of Basic Research Articles Relative to Innovation.**



**Figure 3-15: Pharmaceutical Firms- Gamma of Number of Basic Research Articles Relative to Innovation.**





## Chapter 4:

# Publishing and Patenting: Researcher-Level Evidence from Five Companies

This chapter explores the relationship between patents and publications by researchers at five companies (IBM, AT&T, Intel, DuPont and Merck).

### 4.1 Introduction

Industrial research is an important contributor to scientific progress and a major source of science-based innovations (Jewkes, Sawers and Stillerman, 1958; Mowery and Rosenberg, 1989).<sup>174</sup> Many scholars have studied the relationship between scientific research and patents at industrial firms (e.g., Griliches, 1984; Jaffe, 1986; Patel and Pavitt, 1994). Fewer studies have examined the relationship between patents and publications, taking the researcher — rather than the firm — as the unit of analysis.<sup>175</sup> This is a difficult exercise, because patent and publication databases provide incomplete information about the names and affiliation of researchers, making it harder to match individuals within and across these databases than it is to identify the firm that produced the patent or publication.

In this paper, I explore the relationship between publishing and patent production by researchers at five leading research laboratories (IBM, AT&T, Merck, DuPont, and Intel). To do so, I created a new dataset that combines patents from the U.S. Patent Office database with publications in the Science Citation Index (SCI). This relies on a new technique for matching individuals based on their abbreviated names (see Appendix 4-A).

---

<sup>174</sup> See Hounshell (1996) for a history of industrial research in the United States.

<sup>175</sup> For example, see Gittelman and Kogut (2000); Noyons, Luwel, and Moed (1998); Cockburn, Henderson and Stern (1999); and Zucker, Darby, and Armstrong (1998).

Choosing the individual researcher as the unit of analysis complements previous studies by adding another perspective. One advantage is that it allows for comparisons of *scientists within the same firm*, such as the relationship between their participation in basic research and the number of patents they produced. Performing this comparison at the level of the firm does not allow us to distinguish whether an observed relationship is due to the characteristics of scientists employed by each firm, or other firm-specific effects (such as the product-markets in which the firms compete). A related benefit of individual-level data is that they allow comparisons to be made across scientific disciplines more effectively than do firm-level data, which are clouded by company-specific differences.

Adopting the individual researcher as the unit of analysis allows us to test several important theories. In this paper, I test the following hypotheses:

- Researchers face a tradeoff between basic research and patenting, so that those who are more heavily involved in basic research are *less* likely to patent than those who are more heavily involved in applied research.
- Basic research improves the productivity of researchers, so that those who are more focused on basic research are also *more* likely to patent relative to others who do applied work. (This hypothesis is the opposite of the first hypothesis, above.)
- Researchers that produce more patents are also more likely to publish more articles, either because they have higher abilities, or because firms which provide incentives to encourage publications “balance” these with incentives to encourage patenting (Cockburn, Henderson and Stern, 1999).
- There is a stronger link between basic science and patents in drug discovery than in other areas, at the level of the individual researcher.
- Researchers who co-author with academics and scientists at public-sector laboratories are more likely to obtain patents than are those researchers who do not so co-author.



Some of these hypotheses have been tested at the firm level. For example, Cockburn and Henderson, 1998, show a positive relationship between a firm's productivity and whether its researchers co-author with universities and public-sector laboratories. It would be interesting to see whether the same effects occur at the level of the individual, as this might help us better understand the firm-level effects and offer new insights on behavior within the firm. Other hypotheses have been not formally tested against patent and publication data, such as the claim that researchers choose between participating in science and in engineering (Allen, 1977), and that the link between basic and innovation is closer in drug discovery than elsewhere (Stokes, 1997).

When choosing the individual as the unit of analysis, one should not automatically draw the same conclusions about firms (Judd, Smith and Kidder, 1991, p. 356).<sup>176</sup> For instance, observing a negative relationship between participation in basic research and patent output at the level of the researcher does not necessarily imply that the same relationship holds at the firm level. In particular, some individuals may specialize in basic research and others in patent-production such that the firm benefits from knowledge shared among these workers. Nonetheless, if the *same* effect is observed at both levels of analysis, it is plausible that some degree of aggregation exists.

I found the following in testing the above hypotheses: given two researchers at IBM, AT&T, or Intel who published the same number of articles, the one who published a greater fraction of papers in basic research journals is *less* likely to obtain patents. This supports the view that scientists are different from engineers. However, the opposite relationship holds at Merck and DuPont: the higher the proportion of papers a researcher publishes in basic scientific journals, the *more* likely she is to obtain patents. This is consistent with prior studies that showed a positive impact on productivity of participating in basic research among firms engaged in drug discovery (Gambardella, 1992; Zucker and Darby, 1995). This paper shows that the effect exists at the level of the

---

<sup>176</sup> Using the individual rather than the firm as the unit of analysis is neither better nor worse, only different.

individual researcher. Furthermore, I show that the result for Merck and DuPont is driven largely by publications in the field of *basic chemistry*. Even at these pharmaceutical firms, the relationship between basic research and patents is stronger for chemistry than for other fields; it is also stronger among researchers who work on pharmaceutical R&D than on other areas within the same firm.

Another result is that the number of patents obtained by a researcher is positively related to the number of articles she published. Further research will be needed to determine whether this signals her ability, or because firms that give higher incentives for publishing also increase their incentives for patenting.

Patents are related negatively to the fraction of articles co-authored with academic and public-sector researchers. This is surprising in view of previous research that underscored the importance of “connectedness” at the level of the firm (e.g., Cockburn and Henderson, 1998). One possible explanation is that researchers who co-author with outsiders may be playing the role of gatekeepers (Allen, 1977), increasing the productivity of other researchers within the firm but not necessarily adding to the number of patents they obtain.

The remainder of this paper is organized as follows. Section 4.2 reviews prior research and develops hypotheses on the relationship between patenting and publishing by industrial researchers. Section 4.3 presents the empirical methodology used in the paper. Section 4.4 describes the datasets and algorithms used to identify the corporate affiliation of individuals and to match them based on their abbreviated names. Section 4.5 presents the results and discussion as well as the limitations of this study. Section 4.6 draws conclusions.

## 4.2 The Relationship between Publications and Patents

In this section, I explore how researcher preferences, ability bias, balanced incentives, scientific area and connectedness may affect the relationship between the patents and publications produced by industrial researchers.

### Researcher Preferences

Researchers who work in industrial laboratories face conflicting demands. On the one hand, many would like to perform interesting research that is important to the scientific community — and thus gain peer recognition (Merton, 1973). On the other hand, such research is not necessarily in line with the firm’s financial interests. Research that seeks a fundamental understanding of phenomena (which I term “basic research”) is expensive and has uncertain payoffs. Often, the only extrinsic reward is a publication in an esteemed journal (Stephan, 1996).

In theory, firms would prefer the speculative investigation of “basic research” to be done by others (Nelson, 1959; Arrow, 1962).<sup>177</sup> In contrast, firms are likely to support applied research and development, which have a higher chance of creating new products and services. Applied research is also more likely to be associated with patents, since an invention must exhibit *usefulness* to be patentable.<sup>178</sup> While primarily a source of intellectual property protection, patents also act as a measure of a firm’s innovation output.<sup>179</sup> From the researcher’s point of view, applying for a patent is an onerous activity that takes up time that could otherwise have been spent writing articles or on other activities.

---

<sup>177</sup> National Science Foundation data show that in 1997, industry 67% of U.S. applied research but only 21% of basic research (NSF, 1998, Tables 4-7 and 4-11). These tables also show that private industry’s share of basic research is declining, while its share of applied research is increasing.

<sup>178</sup> An invention must also be novel and non-obvious to be patentable.

<sup>179</sup> There is a well-developed literature on the strengths and weaknesses of patent analysis (see Griliches, 1990). Patents are an *imperfect* measure of innovation: they are highly skewed in their economic value (Hall, Jaffe and Trajtenberg, 1999), and not all innovations are patented.

Faced with this tension between basic and applied research, how should an industrial researcher spend her time? One solution is to choose one alternative over the other. Allen (1977) and Ritti (1971) maintain that researchers are either engineers or scientists. Whereas an engineer is most interested in career advancement within the firm, a scientist cares most about her reputation outside the company. The engineer's goals coincide with those of the firm: to develop new products and succeed commercially. In contrast, the scientist desires professional autonomy and to publish her research (Allen 1977, pp. 37-39). These preferences are due to self-selection as well as the socialization process in educational institutions: engineers typically hold a bachelor's degree, while most scientists earn a Ph.D.

The distinction between scientists and engineers suggests the following hypothesis:

H1: A researcher who is heavily involved in publishing basic research articles is *less* likely to produce patents than one who is heavily involved in publishing applied research articles.

An alternative hypothesis is that there is no tradeoff between basic and applied research. Scientists who publish basic research may be better connected to external sources of knowledge. Therefore, they are more likely to have early access to new ideas that stimulate creativity. For example, Zucker and Darby (1995) show that "star" scientists who are heavily involved in public science play an important part in the productivity of biotechnology firms. Similarly, Gambardella (1992) advocates a science-oriented research environment within firms that gives greater autonomy to researchers and encourages them to publish. Basic and applied research may also be complementary to each other if there are strong feedback loops in the innovation process (Roberts, 1988). In this case, researchers who are more likely to perform applied research may be more likely to contribute to basic science.

If there is no tradeoff between basic and applied research, so that they are complements rather than substitutes, then Hypothesis H1 is reversed:

H1': A researcher who is heavily involved in publishing basic research articles is *more* likely to produce patents than one who is heavily involved in publishing applied research articles.

### **Ability bias and balanced incentives**

In practice, is difficult to test the above hypotheses because other factors affect the relationship between patents and publications. The most important is that people have different abilities. Moreover, this ability bias may be magnified by the “Matthew Effect” (Merton, 1973), in which success breeds further success. Therefore, a successful researcher may have better opportunities to perform basic research as well as better organizational resources for obtaining patents.

A related issue is that firms which offer greater incentives for researchers to publish scientific results also provide them with stronger incentives to produce patents, as this encourages individuals to balance their efforts between patenting and publishing (Cockburn, Henderson and Stern, 1999).

The differential ability of researchers, coupled with the balancing of incentives by firms, would lead us to expect that researchers who produce a greater number of publications (basic plus applied) are also more likely to obtain a greater number of patents:

H2: Researchers who publish more articles also receive more patents.

It would be interesting to distinguish the effects of ability bias from balanced incentives, but this would require additional data presently not available in my dataset.

### **Area of scientific research**

The relationship between publications and patents is also likely to depend on the scientific area under investigation. Stokes (1997) observes that the dichotomy between basic and applied research breaks down in the field of medicine: medical research is performed both in the quest for fundamental breakthroughs as well as to create practical remedies. Hence, it is likely that researchers who work to discover new drugs are more likely to obtain patents than researchers who work in other fields.<sup>180</sup> I therefore propose the following:

H3: In the area of drug discovery, a researcher who participates heavily in basic scientific research is *more* likely to receive patents than is a researcher less involved in basic research.

H3': In other areas, a researcher who participates heavily in basic scientific research is *less* likely to receive patents than is a researcher who is less involved in basic research.

### **Co-authorship and connectedness**

Another factor that might affect a researcher's likelihood to obtain patents is the extent to which she co-authors articles with scientists at universities and other public-sector laboratories. Such co-authorship is distinct from having a preference for basic research. An industrial researcher may co-author heavily with researchers from outside her firm, but much of it could be applied research. Prior research shows a relationship between a firm's productivity and its rate of co-authorship with universities and public sector laboratories (Cockburn and Henderson, 1998). It is not known whether this relationship holds for individual researchers as well as for firms. I hypothesize that the exchange of ideas among co-authors makes these researchers better connected to sources of new technical ideas and may lead them to produce a greater number of patents.

---

<sup>180</sup> Allen's (1977) work on the dichotomy between scientists and engineers is based on data collected at two engineering laboratories. It is interesting to inquire whether the results apply equally well to drug discovery.

H4: An industrial researcher who co-authors with academics and public-sector researchers is more likely to obtain patents than are industrial researchers who do not so co-author.

### **Firm-level controls**

The firm that employs a researcher also influences the extent to her which participation in basic science translates into a larger number of patents. In part, this is because firms produce different goods and services, and therefore pursue research in different scientific fields. In addition, the industries in which they compete have different degrees of appropriability (Levin *et al.*, 1987). This affects the extent to which firms rely on patents vis-à-vis secrecy and time-to-market. Furthermore, von Hippel (1988) shows that some firms play a key role in developing innovations, while others depend on users or suppliers to take the lead. Firms also vary in size and their ability to capture economies of scope with regards to knowledge spillovers. Firms also exert strong selection pressures on the types of researchers they attract and those they eventually employ. For these reasons, it is important to control for firm-level differences when comparing the patenting and publication behavior of industrial researchers.

In the next section, I describe an empirical methodology to test the hypotheses outlined above.

## **4.3 Methodology**

Let the number of patents awarded to researcher  $i$  in firm  $j$  be denoted by  $Pat_{ij}$ . Similarly, let the number of articles published by this researcher be  $Pub_{ij}$ . The extent of her participation in basic research is reflected in the percentage of articles she published in “basic” scientific journals,  $PctBas_{ij}$ . The following model relates these variables:

$$(1) \quad Pat_{ij} = \mathbf{a} + \mathbf{b} * Pub_{ij} + \mathbf{g}_j (\mathbf{d}_j * PctBas_{ij}) + \mathbf{f} * PctCoau_{ij} + \mathbf{c}_j \mathbf{d}_j$$

where  $\delta_j$  are dummy variables for each firm, and  $PctCoau_{ij}$  is the percentage of articles co-authored with academics and other public-sector scientists

This specification attempts to capture the effect of participating in basic research on patenting ( $PctBas_{ij}$  on  $Pat_{ij}$ ), “controlling” for ability bias and balanced incentives through the effect of  $Pub_{ij}$  on  $Pat_{ij}$ . Conditional on observing two researchers with the same number of publications, it asks whether the one who published a higher percentage of articles in basic scientific journals is more likely to obtain patents. I also added another variable,  $AvgSCI_{ij}$ , to further control for ability bias. For a given researcher,  $AvgSCI_{ij}$  is the average of the SCI impact scores of the journals in which she publishes.<sup>181,182</sup> Despite my attempts to control for ability bias, it is still possible that the researcher who published a higher percentage of articles in basic journals had higher ability than the other, but that remains a limitation of this study.

Equation (1) takes into account the difference among companies by including a fixed effect for each firm ( $\delta_j$ ), so that each firm has a different intercept,  $\mathbf{a} + \mathbf{c}_j$ . In addition, the firm dummy is interacted with  $PctBas_{ij}$ , so each firm has a different slope,  $\mathbf{g}$ . The number of patents awarded to researcher  $i$  is also affected by the percentage of articles she co-authors with academics and public-sector researchers ( $PctCoau_{ij}$ ).

We can test the hypotheses in the previous section by estimating the parameters of this model. Testing the hypothesis that  $\mathbf{g} = 0$  tells us whether researchers who participate heavily in basic research are more likely to be awarded patents than those who concentrate on applied research (hypotheses H1, H1’). Testing  $\mathbf{b} = 0$  indicates whether researchers who publish more articles also receive more patents (hypothesis H2). We can test hypothesis H4 — that researchers who co-author with outside researchers are more

---

<sup>181</sup> Each journal’s SCI impact score is published with the Science Citation Index. I used impact scores for 1997. These scores are very stable across time (see Appendix 3-B).



likely to patent — by estimating  $\mathbf{f}$ . A value of  $\mathbf{f} > 0$  would be consistent with this hypothesis, while a value of  $\mathbf{f} \leq 0$  would reject the hypothesis. To test for differences among firms, we can examine whether firms have the same intercept terms ( $\mathbf{c}_1 = \mathbf{c}_2 = \dots = \mathbf{c}_n$ ) and the same slope coefficients ( $\mathbf{g} = \mathbf{g} = \dots = \mathbf{g}$ ).

The basic model can be modified to test Hypothesis H3, which proposes a stronger relationship between basic research publications and patents for researchers in the field of drug discovery than those in other areas. For each scientific discipline ( $k$ ), a separate coefficient  $\mathbf{g}_{jk}$  can be estimated as follows:

$$(2) \quad Pat_{ij} = \mathbf{a} + \mathbf{b} * Pub_{ij} + \sum_k \mathbf{g}_{jk} (\mathbf{d}_j * PctBas_{ijk}) + \mathbf{f} * PctCoau_{ij} + \mathbf{c}_j \mathbf{d}_j$$

Among the papers published by researcher  $i$  from firm  $k$ ,  $PctBas_{ijk}$  is the percentage of those papers that appear in basic scientific journals in scientific field  $k$ . It is *not* the share of basic research publications in field  $k$  by researcher  $i$ . The estimated value  $\mathbf{g}_k$  tells us whether a scientist who concentrates on publishing basic research in field  $k$  is more likely to receive patents than another researcher who concentrates less on it.<sup>183</sup>

### **Basic versus Applied journals**

An essential ingredient in this methodology is the ability to distinguish between a “basic” and “applied” journal. This paper relies on the journal classification scheme developed by CHI research.<sup>184</sup> Each journal is assigned a number from zero to four, indicating increasing basicness (see Hicks, 1996 for details). In this paper, I define a journal as “basic” if it scores a four; all other journals are “applied.” Naturally, this

---

<sup>182</sup> The expected effect of  $AvgSCI_{ij}$  on patenting is uncertain: publishing in highly cited journals signals a researcher’s ability, but might also take time and effort away from creating patentable inventions.

<sup>183</sup> An alternative would be to create dummy variables to indicate the field in which a researcher works. The shortcoming of this approach, however, is that some researchers work in multiple fields. Furthermore, using percentages rather than dummies measures the *strength* of participation in a particular field of basic research.

<sup>184</sup> I thank Diana Hicks for sharing these valuable data.

approach ignores heterogeneity among articles within the same journal. However, it is the only tractable approach given the large number of publications in the dataset.

In order to identify scientific disciplines, I use another journal classification scheme from CHI Research. The classification used is very similar to that in the Journal Citation Reports, which are published as an accompanying volume to the Science Citation Index each year.

### **Research Setting**

I estimate the model for researchers at five leading companies spanning a broad range of industries: IBM, AT&T, Merck, DuPont, and Intel. IBM produces computers, microelectronics, and information services; AT&T is involved in telecommunications and microelectronics; Merck is a leading pharmaceuticals company; DuPont is involved in pharmaceuticals, chemicals, and materials science; and Intel specializes in semiconductors.

Each of these five firms is an important innovator. AT&T created the transistor (Nelson, 1962; Riordan and Hoddeson 1997); DuPont created Rayon, Nylon and Teflon (Mueller, 1962); Intel invented the microprocessor (Jackson, 1997, pp. 69-77); Merck was the first to create vaccines against mumps, measles, rubella, and hepatitis (Galambos and Sewell, 1995); and IBM has created many important computer and semiconductor technologies (Campbell-Kelly and Aspray, 1996).<sup>185</sup>

While IBM, AT&T, DuPont and Merck have excellent central research laboratories, Intel was added to the analysis for its very different R&D strategy: with no central research laboratories, Intel performs R&D on the manufacturing floor and relies heavily on relationships with universities and other firms for basic scientific knowledge (Moore, 1996).

## 4.4 Data

The dataset contains U.S. Patents (1976-99) and publications in the SCI (1985-97) by these companies.<sup>186</sup> I used U.S. Patent data for the entire period to identify inventors within each firm. However, I used only patents between 1985 and 1997 in the regression analysis, to coincide with the period for which publication data were available in electronic format. I performed a careful search to obtain patents that list the firms in the sample as “assignees,” and searched the SCI for all publications that include the name of these firms among those listed in the “author address” field.

The publication and patent record reflects the characteristics of these firms (see Table 4-1). The large number of patents and publications produced by IBM and AT&T reflects these companies’ size.

There is a remarkable variation in the percentage of articles published in basic research journals by the five companies. About half of the DuPont and Merck articles are in basic scientific journals, while the figure is around one-third for IBM and AT&T. Only 5% of Intel’s articles are published in basic journals, which is unsurprising given its R&D strategy described above.

The breakdown of publications by scientific area reflects the different product markets within which these firms compete. Most of the IBM, AT&T, and Intel publications are on physics, engineering/technology, or chemistry. Merck articles focus primarily on clinical medicine, followed by biomedical research and chemistry. DuPont’s major field of publication is chemistry, but the firm also produces a large number of articles on clinical medicine, biomedical research, and physics— reflecting DuPont’s diversification across a broad range of industries.

---

<sup>185</sup> IBM’s most famous inventions include the fabled S/360 computer and Deep Blue.

<sup>186</sup> These are the periods for which patent and publication data were available to me in electronic format.

**Table 4-1: Summary Statistics for Each Company**

	<b>DuPont</b>	<b>Merck</b>	<b>AT&amp;T</b>	<b>IBM</b>	<b>Intel</b>
<b>Patents</b>					
Number of Patents (1976-1999)	9938	4974	12364	22078	3330
Number of Patents (1985-1997)	6007	2822	6930	12452	1752
<b>Publications in SCI Journals (1985-1997)</b>					
Total Number	8428	10443	19724	20049	665
Articles Published in Basic Journals	4466	5080	6698	7072	31
Percentage Basic Research	53%	49%	34%	35%	5%
<b>Publications in SCI Journals (1985-1997) by Scientific Area</b>					
- Biology	357	375	24	15	1
- Biomedical Research	1141	2801	387	371	5
- Chemistry	3715	2160	2463	3368	70
- Clinical Medicine	1284	4855	143	200	3
- Engineering & Technology	746	41	5011	4752	370
- Mathematics	20	40	699	496	7
- Physics	918	24	10289	10340	198
- Multidisciplinary	124	90	274	213	4
- Other	123	57	434	294	7

Notes:

- Patents and publications by the Dupont-Merck subsidiary (which existed from 1991) are excluded, because they would have introduced ambiguity when trying to identify the affiliations of authors and inventors. The numbers involved were small: Dupont-Merck obtained 208 patents (1976-1999) and published 1,219 articles (1985-1997).
- The multidisciplinary journals are: *Science*, *Nature*, *Recherche*, and *Search*.

#### **4.4.1 Identifying the Inventors and Authors of each Firm**

Once I identified the patents and publications by each firm, the next step was to identify authors and inventors associated with each firm. An “inventor” is a researcher listed in a patent, while an “author” is one who published an article.

It is not easy to identify the inventors and authors of each firm. The patent and publication databases show the addresses of all authors and inventors, but neither specifies which address belongs to which person. This is only a minor problem for the patent database because most patents are assigned to only one firm. However, it is a major problem with publications because of the large number of articles co-authored by researchers at these firms with outside researchers. In general, it is impossible to link a specific author with a specific firm. I used the following heuristic to identify individuals associated with each firm:

- For publication with one address (or multiple addresses that all refer to the same firm), I associated all the authors of that publication with the company listed in the address. I term these individuals “positively associated.” The database is then searched to identify co-authored articles that include each of the positively associated authors within each firm.
- I used an analogous process to associate inventors of patents with firms.
- I cross-referenced the patent and publication databases to identify individuals positively associated to firms in one database but not in the other database.

I dropped from the analysis any individuals who could not be positively identified through the process described above. It was impossible to determine whether they were individuals from *other* organizations who published or patented jointly with researchers from firms in the sample, or individuals from the firms in the sample who had never single-authored a paper or published one exclusively with other people from the same firm.

#### **4.4.2 Matching the Abbreviated Names of Authors and Inventors**

A second limitation with the data concerns the use of author abbreviations. While the patent database contains the full name of each inventor of each patent, the SCI —

unfortunately — identifies authors only by abbreviation. For example, John Harry Truman is identified as Truman-JH.

This raises two issues. First, it creates a risk that several people might be confounded as a single individual because they share the same abbreviation (e.g., Smith-J could refer to John Smith or Jane Smith). I refer to these as “overdetermined” abbreviations.

Second, a systematic technique is needed to match abbreviations of authors and inventors within each company that refer to the same person (e.g., Truman-J and Truman-JH may both refer to John Henry Truman). The absence of such a technique could distort the results. For example, Willis-A might have a large number of patents but appear to have no publications, while in fact the publications are listed under Willis-AXP.

The Appendix 4-A presents an algorithm that matches individuals with similar abbreviated names who are likely to be the same person (this is a novel contribution of my paper). A manual examination of the database shows that this algorithm works very well for matching the abbreviations of *inventors*, for which full names are available for verification. However, there is a risk of matching *authors* with similar abbreviations, but who received no patents.<sup>187</sup> While this remains a possibility, the risk is very low: of the 37,831 inventors positively associated with firms, only 140 had overdetermined abbreviations. It is unlikely that the rate of people with the same abbreviations is much higher among authors than among inventors. Furthermore, the results are robust when I exclude individuals with common last names such as “Smith” (see section 4.5.2). Their common last names make these people the most likely ones to share abbreviations with others.

---

<sup>187</sup> As long as these authors received at least one patent, the problem doesn't arise, since each inventor's full name is known and is assigned a unique abbreviation.

### 4.4.3 The Results of the Algorithms to Identify and Match Authors and Inventors

Table 4-2 summarizes the number of researchers identified per firm and the results of matching them using their abbreviations. The corporate affiliations of most inventors could be identified. However, only about one-third of authors could be positively identified with each company. The rest were dropped from the analysis.<sup>188</sup>

**Table 4-2: Inventors and Authors Identified and Matched in Each Firm**

	DuPont	Merck	AT&T	IBM	Intel
<b>Inventors (1976-1999)</b>					
Number of inventors in each company's patents <sup>†</sup>	5456	2767	9133	19057	2309
Number of inventors positively identified with each firm <sup>*</sup>	5294	2697	8740	18837	2263
<b>Authors (1985-97)</b>					
Number of authors in each company's publications <sup>†</sup>	11269	17250	16540	19097	1463
Number of authors positively identified with each firm	4012	5996	6603	8163	471
<b>Researchers Positively Identified with Each Firm After Matching by Abbreviation</b>					
Total number of researchers positively identified with this firm	7771	6233	12006	22470	2465
Of which:					
- Researchers who only patent	3958	1149	5725	14752	1997
- Researchers who patent and publish	1336	1548	3015	4085	266
- Researchers who only publish <sup>Ψ</sup>	2477	3536	3266	3633	202

Notes:

\* Of the 37,831 inventors positively associated with these firms, only 140 inventors had overdetermined abbreviations (e.g., Larry Smith and Laura Smith are both Smith-L). These were subsequently dropped.

† Includes individuals from universities and other firms that co-authored or co-invented with researchers within these firms

Ψ This is a lower bound for the total number of researchers who published but did not patent, since some authors could not be positively identified with each firm.

The lower half of Table 4-2 shows the results of running the matching algorithm of section 4.4.2. It is interesting that, with the exception of Merck, the companies have far fewer researchers who obtained patents *and* published articles than researchers who obtained patents but *did not* publish. This suggests that, relative to Merck, there is a weaker link at the level of the individual between publications and inventions in the other companies.

## 4.5 Results and Discussion

### 4.5.1 Descriptive Statistics

Table 4-3 shows the variables used in the regressions. They vary considerably, as revealed by the wide standard deviations and their maximum and minimum values.

The sample contains 41,325 researchers who had published articles and/or received patents between 1985 and 1997. Each researcher was awarded an average of 1.8 patents. The average researcher published 3.9 articles, of which 1.5 were in basic science journals. Conditional on having published at least one article, a researcher published 29% of her articles in basic science journals.<sup>189</sup> The  $PctCoau_{ij}$  variable shows that on average, each researcher co-authored one-third of her articles with scientists at academic or government laboratories. The intensity of basic research in various scientific fields is shown in the middle portion of Table 4-3. The fields in which the average researcher published the highest percentage of her papers in basic research journals are chemistry, biomedical research and physics.

---

<sup>188</sup> As previously mentioned, they might be co-authors from outside the firm, or people within the firm who have never published a single-authored article or published one which involves only other authors from within the firm.

<sup>189</sup> The number of papers published by a researcher appears in the denominator and cannot be zero.



**Table 4-3: Variables used in the Regressions**

Variable	Description	N	Mean	StdDev	Min	Max
<b>Main Variables</b>						
Pat <sub>ij</sub>	Number of patents by this researcher (1985-1997)	41325	1.8	3.6	0	94
Pub <sub>ij</sub>	Number of publications by this researcher (1985-1997)	41325	3.9	11.4	0	429
PubBas <sub>ij</sub>	Number of publications by this researcher in “basic” journals	41325	1.5	6.3	0	202
PctBas <sub>ij</sub>	Percentage of publications by this researcher in “basic” journals	23279	0.29	0.39	0	1
PctCoau <sub>ij</sub>	Percentage of publications by this researcher co-authored with academic or public-sector laboratories	23279	0.23	0.32	0	1
AvgSci <sub>ij</sub>	Average SCI Impact Scores of the journals in which this researcher publishes.	22065	2.4	2.4	0.08	38.9
<b>Percentage Basic Research by Scientific Area</b>						
Pc_bas_biol	Percentage of publications by this researcher in basic biology journals	23279	0.09	0.07	0	1
Pc_bas_biomed	Percentage of publications by this researcher in basic biomedical journals	23279	0.07	0.22	0	1
Pc_bas_chem	Percentage of publications by this researcher in basic chemistry journals	23279	0.12	0.27	0	1
Pc_bas_clinical	Percentage of publications by this researcher in basic clinical medical journals	23279	0.01	0.09	0	1
Pc_bas_engtech	Percentage of publications by this researcher in basic engineering and technological journals	23279	0.0004	0.01	0	1
Pc_bas_math	Percentage of publications by this researcher in basic mathematics journals	23279	0.002	0.04	0	1
Pc_bas_physics	Percentage of publications by this researcher in basic physics journals	23279	0.07	0.20	0	1
<b>Control Variables</b>						
Comn_lastnam	Dummy for researchers with common last names	1898			0	1
D_Merck	Dummy for researchers positively identified with Merck	41325			0	1
D_Dupont	Dummy for researchers positively identified with DuPont	41325			0	1
D_ATT	Dummy for researchers positively identified with AT&T	41325			0	1
D_Intel	Dummy for researchers positively identified with Intel	41325			0	1

Notes: The subscripts refer to researcher *i* in company *j*.  
For the company dummies, IBM is the base case.  
140 inventors with overdetermined abbreviations were dropped

**Table 4-4: Pairwise Correlation Coefficients**

	<b>Pat<sub>ij</sub></b>	<b>Pub<sub>ij</sub></b>	<b>PubBas<sub>ij</sub></b>	<b>PctBas<sub>ij</sub></b>	<b>PctCoau<sub>ij</sub></b>	<b>AvgSci<sub>ij</sub></b>
<b>Pat<sub>ij</sub></b>	1.00					
<b>Pub<sub>ij</sub></b>	0.16*	1.00				
<b>PubBas<sub>ij</sub></b>	0.11*	0.79*	1.00			
<b>PctBas<sub>ij</sub></b>	-0.02*	0.13*	0.35*	1.00		
<b>PctCoau<sub>ij</sub></b>	-0.01	0.11*	0.11*	0.06*	1.00	
<b>AvgSci<sub>ij</sub></b>	-0.05*	0.13*	0.22*	0.45*	0.11*	1.00

Note: \* = significant at the 5% level.

Table 4-4 shows pairwise correlation coefficients for the key variables. All else being equal, the number of patents awarded to a researcher has a weak negative correlation with the percentage of articles she published in basic scientific journals ( $Pat_{ij}$  with  $PctBas_{ij}$ ). However, the number of patents is positively correlated to the total number of articles she published ( $Pat_{ij}$  with  $Pub_{ij}$ ). The correlation coefficient between  $PctBas_{ij}$  and  $AvgSCI_{ij}$  is rather high at 0.45. This is interesting because across the entire set of journals covered by the Science Citation Index, the correlation coefficient between a journal's SCI impact scores and its basicness is only 0.14. Therefore, researchers from these companies who published a large fraction of their papers in basic journals had published them in highly cited journals.

#### **4.5.2 Regression Results**

Table 4-5 shows ordinary least squares (OLS) regressions with the number of patents awarded to a researcher between 1985 and 1997 ( $Pat_{ij}$ ) as the dependent variable. In Model I,  $PctBas_{ij}$  has a negative coefficient. This is consistent with hypothesis H1', that a researcher who is heavily involved in publishing basic research articles is *less* likely to produce patents than one who is heavily involved in publishing applied research

**Table 4-5: OLS with Number of Patents Awarded to a Researcher as the Dependent Variable**

Independent Variables	Dependent Variable = Pat <sub>ij</sub> (1985-97)				
	(I) Base Model	(II) Coauthor- ship and SCI Impact	(III) With Firm Effects	(IV) Eliminate Common Last Names	(V) Huber- White Robust Std. Errors
<b>Main Variables</b>					
Pub <sub>ij</sub>	0.069* (0.002)	0.071* (0.002)	0.075* (0.002)	0.075* (0.002)	0.075* (0.005)
PctBas <sub>ij</sub>	-0.59* (0.07)	-0.18* (0.08)	-1.82* (0.15)	-1.85* (0.15)	-1.85* (0.11)
PctCoau <sub>ij</sub>		-0.44* (0.08)	-0.22* (0.09)	-0.22* (0.09)	-0.22* (0.08)
AvgSci <sub>ij</sub>		-0.13* (0.01)	-0.11* (0.01)	-0.11* (0.01)	-0.11* (0.01)
Intercept	1.2* (0.03)	1.5* (0.04)	2.02* (0.06)	2.0* (0.06)	2.0* (0.06)
<b>Firm Effects</b>					
D_Merck			-1.41* (0.12)	-1.38* (0.11)	-1.38* (0.10)
D_Dupont			-0.98* (0.11)	-0.96* (0.11)	-0.96* (0.09)
D_ATT			-0.85* (0.08)	-0.84* (0.08)	-0.84* (0.07)
D_Intel			-0.08 (0.20)	0.02 (0.21)	0.02 (0.23)
D_Merck*PctBas <sub>ij</sub>			3.38* (0.21)	3.40* (0.21)	3.40* (0.19)
D_Dupont*PctBas <sub>ij</sub>			2.19* (0.22)	2.20* (0.22)	2.20* (0.17)
D_ATT*PctBas <sub>ij</sub>			0.33 (0.22)	0.32 (0.22)	0.32* (0.14)
D_Intel*PctBas <sub>ij</sub>			1.49 (1.92)	1.40 (1.92)	1.40 (1.01)
<b>Regression Statistics</b>					
N	23279	22065	22065	21045	21045
Adj R-squared	0.06	0.07	0.09	0.09	0.09

Notes: Standard errors are shown in parentheses

\* = significant at 5%

140 inventors with overdetermined abbreviations were dropped

When firm dummies are used, IBM is the base case.

articles. The coefficient for  $Pub_{ij}$  is positive, which favors hypothesis H2 (that researchers with the greatest ability publish more and receive more patents, or that firms attempted to balance incentives). Both coefficients are statistically significant at the 5% level.

Model II incorporates the percentage of papers a researcher co-authored with academic and public-sector scientists ( $PctCoau_{ij}$ ) and the average SCI impact scores of the journal in which each researcher published ( $AvgSCI_{ij}$ ). The effect of these variables is to soak up some of the variation previously explained by  $PctBas_{ij}$ . Surprisingly,  $PctCoau_{ij}$  has a negative and significant relationship to the number of patents awarded to a researcher. This contradicts hypothesis H4 that better-connected researchers are more likely to obtain patents. One possible explanation is that better-connected researchers may be playing the role of gatekeepers (Allen, 1977) — increasing the productivity of others within the firm, but not necessarily obtaining more patents.

Model III incorporates firm dummies to test for inter-firm differences. A Wald test of the hypothesis that each firm has the same intercept is rejected with  $F(4,22052)=61$ . Likewise, a Wald test of the hypothesis that each firm has the same slope for  $PctBas_{ij}$  is rejected with  $F(4,22052) = 84$ . They therefore do not reject the hypothesis that each firm is different in terms of the relationship between the number of patents awarded to a researcher and the extent to which she publishes basic research. The parameter estimates for IBM are given by the case where all the dummies are zero. For the remaining firms, the dummies add a component to the intercept and to slope of  $PctBas_{ij}$ . The dummy variables for Intel are not significantly different from zero, nor is the coefficient for  $D\_ATT * PctBas_{ij}$ . However, the other dummies are statistically significant, so these firms have different slopes and coefficients from IBM. The estimates for each firm (conditional on all other variables) are given by:

$$\begin{aligned} Pat_{i,IBM} &= 2.02 - 1.82 PctBas_{i,IBM} + \dots \\ Pat_{i,ATT} &= 1.17 - 1.49 PctBas_{i,ATT} + \dots \end{aligned}$$

$$\text{Pat}_{i,\text{Intel}} = 1.94 - 0.33 \text{PctBas}_{i,\text{Intel}} + \dots$$

$$\text{Pat}_{i,\text{Merck}} = 0.61 + 1.56 \text{PctBas}_{i,\text{Merck}} + \dots$$

$$\text{Pat}_{i,\text{Dupont}} = 1.04 + 0.37 \text{PctBas}_{i,\text{Dupont}} + \dots$$

The key result is that the coefficient estimates for  $PctBas_{ij}$  are negative for IBM, AT&T and Intel, but positive for Merck and DuPont. Given two researchers at IBM, AT&T or Intel, the one who published a higher fraction of papers in basic scientific journals was less likely to obtain patents, *ceteris paribus*. The opposite is true at Merck and DuPont, with the one who published a higher fraction of papers in basic scientific journals being *more* likely to obtain patents.

This evidence also supports hypothesis H3, that the connection between basic research and patents is stronger in drug discovery than in other areas. Section 4.5.3 explores whether this is due to the different scientific areas or to other firm-specific characteristics (this is important to investigate since DuPont is involved in many areas outside pharmaceuticals).

Model IV eliminates all researchers who have common last names such as Smith, Chen, Lee, Jones, and so on. This reduces the likelihood of confounding authors who share the same abbreviations, as discussed in section 4.4.2. This makes no significant difference to the results of Model III.

Model V re-estimates the regression using Huber-White robust standard errors. This analysis was performed because a plot of the residuals revealed some heteroscedasticity in the data. The results remain unchanged, except that the coefficient for  $D\_ATT * PctBas_{ij}$  becomes statistically significant at the 5% level.

### 4.5.3 Firm Effects and Scientific Disciplines

As the previous section shows, researchers at DuPont and Merck who publish a large fraction of their papers in basic research were *more* likely to obtain patents than other researchers who published more heavily in applied journals; the reverse is true at IBM, AT&T, & Intel. Is this because the firms have different incentive structures and

**Table 4-6: OLS of Patents per Researcher by Firm and Scientific Area (Robust Standard Errors)**

Independent Variables	Dependent Variable = Pat <sub>ij</sub> (1985-97)				
	Merck	DuPont	AT&T	IBM	Intel
<b>Percentage of Research Published in basic Journals in each Field:</b>					
Pc_bas_biol	0.5* (0.2)	-0.8* (0.2)	-2.8* (0.8)	-2.1* (0.8)	NA
Pc_bas_biomed	-0.5* (0.1)	-0.6* (0.1)	-0.7 (0.4)	-0.5 (0.9)	-4.9* (1.2)
Pc_bas_chem	3.3* (2.6)	1.6* (0.2)	-1.1* (0.2)	-1.0* (0.2)	-1.7* (0.8)
Pc_bas_clinical	1.5* (0.4)	-1.0* (0.1)	-1.1* (0.3)	-1.1 (0.9)	2.5 (3.4)
Pc_bas_engtech	NA	4.5 (4.9)	-0.6 (0.6)	-2.4 (2.7)	NA
Pc_bas_math	NA	NA	-1.6* (0.2)	-2.2* (0.3)	NA
Pc_bas_physics	8.8 (6.2)	-0.7 (0.5)	-1.9* (0.1)	-2.3* (0.1)	NA
<b>Other Variables:</b>					
Pub <sub>ij</sub>	0.15* (0.02)	0.04* (0.01)	0.06* (0.006)	0.07* (0.007)	0.10 (0.07)
PctCoau <sub>ij</sub>	-0.38* (0.19)	0.48* (0.18)	-0.12 (0.09)	-0.21 (0.12)	0.19 (0.54)
AvgSci <sub>ij</sub>	-0.07* (0.01)	-0.04* (0.02)	-0.05* (0.02)	-0.09* (0.02)	-0.31* (0.13)
Intercept	0.04 (0.11)	0.85* (0.08)	1.20* (0.05)	2.03* (0.07)	2.02* (0.32)
<b>Regression Statistics:</b>					
N	4839	3363	6101	7333	429
R-Squared	0.19	0.06	0.13	0.05	0.01

Notes: Robust standard errors are shown in parentheses

\* = significant at 5%

140 inventors with overdetermined abbreviations were dropped

NA denotes a scientific area in which researchers from a firm did not publish in any basic journals.

organizations to support basic research, or because the researchers were in different scientific fields (H3)? To address this question, I performed a separate regression for each firm and included the percentage of basic articles by each researcher in each scientific area. Table 4-6 displays the results,<sup>190</sup> with Huber-White standard errors shown in parentheses.

Table 4-6 reveals that researchers at IBM, Intel, and AT&T who published a higher percentage of basic research in *any scientific field* produced fewer patents. Thus, for these companies, there is a distinction between scientists and engineers regardless of scientific discipline. The disparity appears greater in basic biology, physics, and mathematics than in other fields.

At Merck and DuPont, researchers with a preference for *basic chemistry* were more likely to obtain patents. A Merck scientist who published only in basic chemistry obtained 3.3 more patents than another researcher who published no basic research articles in chemistry. The corresponding figure for DuPont is 1.6. These coefficients are large relative to the average number of patents produced per researcher, which is only 1.8 (Table 4-3). At Merck, basic research in biology also had a positive relationship with patents, while at DuPont it was negative. The result for DuPont is surprising, since one would expect a strong link between pharmaceutical patents and basic biology. Another unexpected finding is the negative relationship between patents and basic biomedical research. For the other scientific fields, the coefficient estimates for basic research were imprecisely estimated, and sometimes even negative.

The overall implication of the results for Merck and DuPont is that the positive relationship between basic research and patents observed in the previous section is driven largely by publications in basic chemistry. Thus, *the dominant effect is that of scientific*

---

<sup>190</sup> Several parameters could not be estimated for Intel because the firm did not publish basic research in those areas.

*discipline, rather than the firm per se*: even at Merck and DuPont, there is a weak relationship between basic research and patents outside basic chemistry.

An issue that arises is that the coefficient for basic chemistry for DuPont is much less than for Merck. Could this be because DuPont is more diversified than Merck, which is primarily a pharmaceutical company? To answer this question, I repeated the analysis but included only researchers who obtained patents in U.S. Patent Classes 424 and 514 (drugs, bio-affecting and body treating compositions). This subset of researchers definitely performed pharmaceutical R&D.<sup>191</sup> As shown in Table 4-7, the results for Merck are qualitatively the same as before.<sup>192</sup> This is important because it suggests that researchers who received patents in the aforementioned patent classes are representative of Merck (and presumably of pharmaceutical research).

For DuPont, the results are now very similar to those for Merck. A typical DuPont researcher who published articles only on basic chemistry obtained 4.1 more patents than another who performed no basic chemistry research, *ceteris paribus*. This is much higher than before, and close to the corresponding estimate for Merck, which is 5.8.<sup>193</sup> This means that *a stronger relationship between basic chemistry research and patents exists in pharmaceutical R&D than in other areas, even within the same firm (DuPont)*.

The rest of the parameter estimates for DuPont in Table 4-7, where precisely estimated, are qualitatively similar to those for Merck. Basic biological research again exhibits a surprising negative relationship to patents, although this time it is not statistically significant.

---

<sup>191</sup> Pharmaceutical researchers also obtain patents in other U.S. patent classes, including 435, 436, 530-570, and 585. However, these patent classes overlap with various fields of chemistry unrelated to pharmaceuticals.

<sup>192</sup> Due to the small sample size, some of the parameter estimates are now imprecise.

<sup>193</sup> The average number of patents per researcher at Merck and DuPont are 1.6 and 1.7, respectively.



**Table 4-7: OLS for Researchers who Received Patents in U.S. Patent Classes 424 and 514 (drugs, bio-affecting and body treating compositions).**

Independent Variables	Dependent Variable = Pat <sub>ij</sub> (1985-1997)	
	Merck	DuPont
<b>Percentage Basic Research in Each Field</b>		
Pc_bas_biol	-0.8 (1.2)	-2.7 (1.9)
Pc_bas_biomed	-3.5* (0.9)	0.1 (1.1)
Pc_bas_chem	5.8* (1.0)	4.1* (2.1)
Pc_bas_clinical	3.4* (1.4)	-3.8 (2.6)
Pc_bas_engtech	NA	NA
Pc_bas_math	NA	NA
Pc_bas_physics	54 (51)	-4.1 (4.0)
<b>Other Variables</b>		
Pub <sub>ij</sub>	0.17* (0.03)	0.02 (0.02)
PctCoau <sub>ij</sub>	-1.61* (0.69)	-0.10 (0.81)
AvgSci <sub>ij</sub>	-0.19* (0.09)	-0.28* (0.13)
Intercept	3.52* (0.66)	4.29* (0.89)
<b>Regression Statistics</b>		
N	859	151
R-Squared	0.21	0.09

Notes: Pat<sub>ij</sub> refers to the number of patents obtained by these researchers in *all patent classes*.  
 Robust standard errors are shown in parentheses  
 \* = significant at 5%  
 NA denotes a scientific area in which researchers from a firm did not publish in any basic journals.

Apart from the results for basic research, Tables 4-6 and 4-7 reconfirm the positive relationship uncovered in section 4.5.2 between patents and the total number of publications by a researcher. As before, co-authorship with outside researchers is

negatively related to patents.<sup>194</sup> And publishing in highly cited journals is negatively associated with patents, as previously shown.

#### 4.5.4 Limitations and Sources of Bias

The regression analysis explains only 6-9% of the variance in the data, as evident from the low R-squared values in Tables 4-5, 4-6 and 4-7. The exception is Merck, for which the R-squared is relatively high, around 0.2 (see Tables 4-6 and 4-7). The poor overall fit is unsurprising, given that many other factors affect the relationship between patents and publications, including individual preferences for leisure and other activities, occupational and educational background, demographics, and so on. Despite this shortcoming, the estimated coefficients generally have low standard errors and are stable across models. They have statistically significant implications for the theories tested.

Another limitation of this study is that it includes researchers from only five companies. These companies are interesting and important in themselves, but much work remains to expand the sample to other firms.

There are also data limitations arising from the use of the Science Citation Index database. I overcame several of these limitations by using the algorithms to identify the authors of each firm and match them using their abbreviated names. Nonetheless, a large number of authors listed in the publications by these firms could not be positively identified with the firms. In contrast, recall that almost all inventors are included in the analysis (see Table 4-2). Therefore, the missing data creates a *downward bias*, since it mainly contains researchers who have publications (including basic research articles) but no patents.

---

<sup>194</sup> For Du Pont, the coefficient estimate for  $PctCoau_{ij}$  is positive and significant in Table 4-6, but becomes negative and significant in Table 4-7, which only includes researchers who worked on pharmaceutical R&D.

A separate source of bias arises from researchers who patented inventions but did not publish anything. These individuals are automatically dropped because the number of publications appears as the denominator of  $PctBas_{ij}$ . In this case, the direction of bias is *upwards*: these individuals were able to obtain patents without even publishing anything (let alone publishing basic research), meaning that the link between research and innovation may be weaker than I measured it to be.

## 4.6 Conclusions

A comparison of two researchers at IBM, AT&T, or Intel who published the same number of papers reveals that the one who published a higher proportion of her research in basic scientific journals obtained fewer patents. The opposite was true for Merck and DuPont, but this was largely driven by a positive relationship between *basic chemistry* research and patents. The link is weaker between patents and other areas of research, even within these two pharmaceutical firms. In the case of DuPont, the relationship between basic chemistry and patents was stronger for researchers working on drug discovery than for the firm as a whole.

Further research is required to learn whether these findings can be generalized. If so, it means that while scientists and engineers are inherently different, there is a special role in drug discovery played by scientists who perform basic research. In particular, participation in basic chemistry research by these individuals is strongly associated with the production of new, patentable ideas. While a relationship between scientific publications and productivity has been reported before for pharmaceutical firms, it is remarkable that it occurs at the level of the individual researcher.

The low correlation between basic biological research and patents is rather surprising. My interpretation of this result is that chemistry was the primary basis for drug discovery during the period this sample covers (1985-1997). A closer link with biology only began to emerge with the advent of rational drug design and genetics in the

1990's (Cockburn, et al., 1999). Given the gestation period required to produce new drugs and the time lags associated with patenting and publishing, these data will take time to appear in the database.

Apart from these results, I also found a positive correlation between the number of patents obtained by a researcher and the total number of articles (basic plus applied) that she published. This most probably reflects the heterogeneity in the ability of individual researchers, and/or the firms balancing the incentives for their researchers to produce patents versus publications. Further work will be needed to disentangle these effects.

The results for co-authorship revealed a surprise: there is a negative correlation between the number of patents obtained by a researcher and the percentage of her publications that are co-authored with academics and public-sector researchers. Further research will be needed to gain a full understanding of this result.

This chapter presents several important contributions. It attempts to develop a systematic understanding of the relationship between patents and publications by researchers at leading industrial firms. It tests the implications of several competing theories on the relationship between basic research and patents and shows how applicability of such theories depends upon the scientific discipline in which a researcher is engaged. Finally, the technique developed for matching inventors, authors, and firms may have other potentially useful applications.

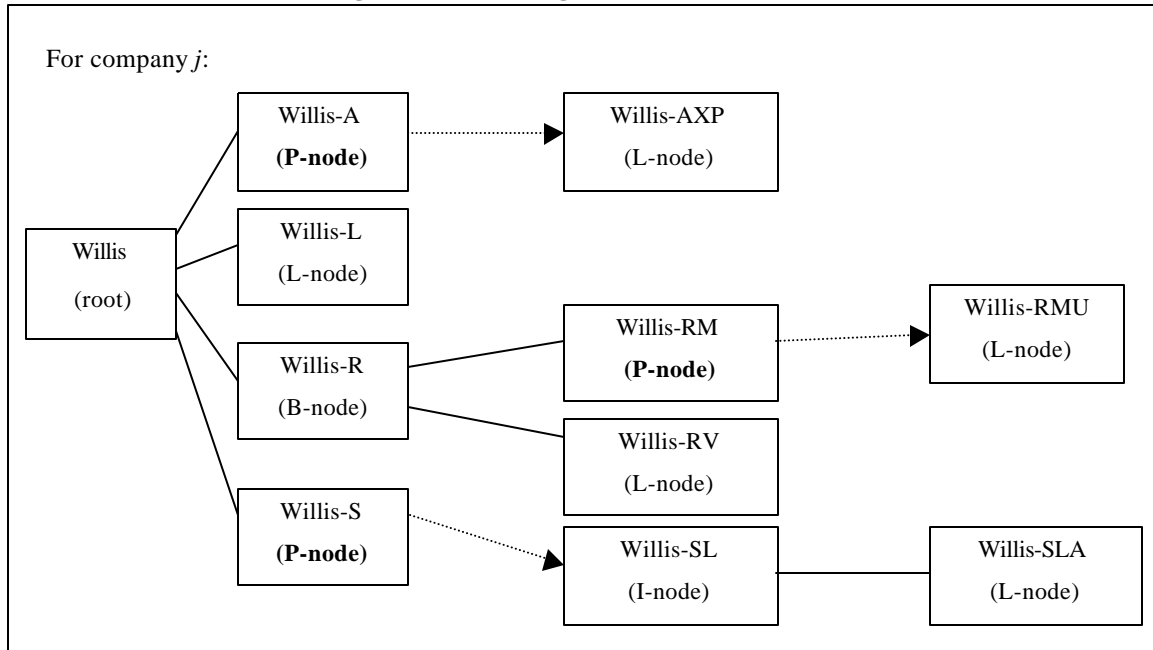
## Appendix 4-A: Algorithm for Matching Authors and Inventors

The U.S. patent database contains the full name of each inventor of each patent, but the Science Citation Index (SCI) identifies authors only by abbreviation. For example, John Harry Truman is identified as Truman-JH. I designed the following algorithm to match authors of publications in the SCI to inventors of U.S. patents, based on each researcher's abbreviated names.

Steps:

- First, I corrected misspellings in the patent and publication datasets.
- Next, I assigned a unique abbreviation that *maximally differentiates* each inventor in the patent database. For example, Ron Willis, Ron M. Willis, and Ronald Willis were abbreviated as Willis-RM, not Willis-R (note that Willis-R would not maximally differentiate this individual if the database also included a Rachel V. Willis, who would be Willis-RV).
- I marked abbreviations that refer to more than one individual as “overdetermined” (e.g., Smith-J, which refers to John Smith and Jack Smith).
- For each company, I created a tree structure from the abbreviated names of all authors and inventors (see Figure 4-1). Each last name is a “root” of the tree. I then classified each node of the tree into one of four types (L, B, I or P) as described below. The purpose is to identify nodes that can be combined with other nodes because they refer to the same individual. L, B and I nodes cannot be combined, while P nodes must be checked to see if they can be combined, or “promoted.”
- After each node has been classified, the entire tree is traversed along each arc starting from the root. Each P-node is matched to the next node along its arc until reaching a leaf node or until a B-node or an I-node blocks the path. The result is shown as dashed lines in Figure 4-2. Willis-A is matched to Willis-AXP and Willis-RM is matched to Willis-RMU. However, Willis-SL is not matched to Willis-SLA because they refer to different inventors (Samuel and Sandra).

**Figure 4-1: Matching Authors to Inventors**



Shown is a hypothetical case for individuals who share the last name “Willis”:

- Each node is the abbreviated name of an author or inventor.
- The “Willis” node is the root of the tree; each line is called an “arc”.
- The nodes are classified into four types: (L)=leaf, (B)=branch, (I)=invariant, and (P)=promotable. Only p-nodes can be matched to other nodes.
- The dashed arrows show abbreviations matched by running the algorithm. Willis-A is matched to Willis-AXP, Willis-RM is matched to Willis-RMU, and Willis-S is matched to Willis-SL. Observe that Willis-SL is not matched to Willis-SLA because they refer to different inventors (Samuel Lee Willis and Sandra Lauren A. Willis).

**Figure 4-2: Types of Nodes**

- L-nodes: A *leaf* node refers to an abbreviation that is not part of another, longer, abbreviation (e.g., Willis-AXP, Willis-RV).
- B-nodes: A *branch* node is part of several longer abbreviations along *divergent* arcs. For example, Willis-R is a branch node because both Willis-RM and Willis-RV exist and diverge into separate paths. B-nodes cannot be matched to longer abbreviations because of the ambiguity caused by branching. Thus, Willis-R cannot be matched to Willis-RM or Willis-RV.
- I-nodes: An *invariant inventor* node refers to an inventor whose abbreviated name is part of another inventor's with a longer abbreviation.<sup>195</sup> In Figure 4-1, Willis-SL and Willis-SLA refer to "Samuel Lee Willis" and "Sandra Lauren A. Willis," respectively. Therefore, Willis-SL is an I-node. I-nodes cannot be matched to longer abbreviations because they refer to different inventors.
- P-nodes: The remaining nodes are *promotable*.<sup>196</sup> They must be checked to see if there exists a longer abbreviation along the same arc. If so, they are matched to the longer abbreviation, unless the path is blocked by a B or I node. For example, Willis-A is matched to Willis-AXP, since there are no obstacles on the arc between the two nodes.<sup>197</sup>

---

<sup>195</sup> It is impossible to do this for authors because their full names are unavailable.

<sup>196</sup> By "promotable" I mean that the node must be tested to see whether it can be merged into another node that is further from the root and closer to a leaf.

<sup>197</sup> The fact that Willis-A is a "P-node" means that there cannot be another inventor with the abbreviation Willis-AXP. Otherwise Willis-A would have been classified as an "I-node."





## **Bibliography**

### **Economics and Management**

- Adams, J.D. ,1990, Fundamental stocks of knowledge and productivity growth, *Journal of Political Economy* 98, 673-702.
- Allen, T.J., 1977, *Managing the Flow of Technology*, MIT Press, Cambridge, MA.
- Appleyard, M., 1996, How does knowledge flow? Interfirm patterns in the semiconductor industry, *Strategic Management Journal* 17 (Winter Special Issue), 137-154.
- Arora, A., Gambardella, A., 1994, Evaluating technological information and utilizing it, *Journal of Economic Behavior and Organization* 24, 91-114.
- Arrow, K., 1962, Economic welfare and the allocation of resources for invention, in R.R. Nelson (ed.), *The Rate and Direction of Inventive Activity*, Vol. 13 of NBER Special Conference Series, Princeton University Press, NJ, 609-625.
- Baranson, J., 1970, Technology transfer through the international firm, *American Economic Review* 60(2), 435-440.
- Bresnahan, T., Trajtenberg, M., 1995, General purpose technologies: engines of growth, *Journal of Econometrics* 65, 83-108.
- Burt, R.S., 1992, The social structure of competition, in: N. Nohria and R.G. Eccles (Editors), *Networks and Organizations* (Harvard Business School Press, Boston) pp. 57-91.
- Bush, V., 1945, *Science: The Endless Frontier*, National Science Foundation, Washington D.C.
- Campbell-Kelly, M., 1996, Aspray, W., *Computer: a History of the Information Machine*, BasicBooks, New York.
- Cockburn, et al., 1999, Pharmaceuticals and biotechnology, in D. Mowery (Editor), *U.S. Industry in 2000: Studies in Competitive Performance* (National Academy Press, Washington, D.C.) pp. 363-398.
- Cockburn, I., Henderson, R.M., 1998, Absorptive capacity, co-authoring behavior and the organization of research in drug discovery, *Journal of Industrial Economics* 46(2), 157-182.
- Cockburn, I., Henderson, R.M., Stern, S., 1999, Balancing incentives: the tension between basic and applied research, NBER working paper W6882.
- Cohen, W.M., Levinthal, D., 1989, Innovation and learning: the two faces of R&D, *Economic Journal* 99, 569-596.

- Cohen, W.M., Levinthal, D., 1990, Absorptive capacity: a new perspective on learning and innovation, *Administrative Science Quarterly* 35, 128-152.
- Collins, P., Wyatt, S., 1988, Citations in patents to the basic research literature, *Research Policy* 17, 65-74.
- Curry, B., George, K.D., 1983, Industrial concentration: a survey, *Journal of Industrial Economics* 31 (3), 203-255.
- Ellison, G., Glaeser, E.L., 1997, Geographic concentration in U.S. manufacturing industries: a dartboard approach, *Journal of Political Economy* 105 (5), 889-927.
- Ernst, H., 1998, Industrial research as a source of important patents, *Research Policy* 27, pp. 1-15.
- Galambos, L., Sewell, J.E., 1995, *Networks of Innovation: Vaccine Development at Merck, Sharp and Dohme, and Mulford, 1895-1995*, Cambridge University Press, Cambridge, U.K.
- Gambardella, A., 1992, Competitive advantage from in-house scientific research: the US pharmaceutical industry in the 1980's, *Research Policy* 21, 391-407.
- Garfield, E., 1980, Bradford's law and related statistical patterns, *Current Contents* 19 (May 12<sup>th</sup>), 5-12.
- Gawer, A., 2000, *The Organization of Platform Leadership: An Empirical Investigation of Intel's Management Processes Aimed At Fostering Complementary Innovation by Third Parties*, Doctoral Dissertation, MIT Sloan School of Management.
- Gittelman, M., Kogut, B., 2000, Why do firms publish their research (by their own scientists?): Publication and patenting by US biotechnology firms, NYU Working Paper.
- Granovetter, M. S., 1973, The strength of weak ties, *American Journal of Sociology* 78, 1360-1380.
- Griliches, Z., 1980, Returns to research and development expenditures in the private sector, in: J. Kendrick and B. Vaccara (Editors), *New Developments in Productivity Measurement and Analysis* (University of Chicago Press, Chicago) pp. 419-454.
- Griliches, Z., 1985, *R&D, Patents and Productivity*, University of Chicago Press, Chicago, Illinois.
- Griliches, Z., 1986, Productivity, R&D and basic research at the firm level in the 1970's, *American Economic Review* 76 (1), 141-154.

- Griliches, Z., 1990, Patent statistics as economic indicators: a survey, *Journal of Economic Literature* 18 (4), 1661-1707.
- Griliches, Z., 1992, The search for R&D spillovers, *Scandinavian Journal of Economics* 94(supplement): S29-S47.
- Hall, B.H., 1996, The private and social returns to research and development, in: B. Smith and C. Barfield (Editors), *Technology, R&D and the Economy*, (Brookings Institution, Washington, D.C.) pp. 140-183.
- Hall, B.H., Ham, R.M., 1999, The patent paradox revisited: determinants of patenting in the US semiconductor industry, 1980-1994, NBER Working Paper W7062, Cambridge, MA.
- Hall, B.H., Jaffe, A., Trajtenberg, M., 1999, Market value and patent citations: a first look, NBER working paper.
- Hansen, M., 1999, The search-transfer problem: the role of weak ties in sharing knowledge across organization subunits, *Administrative Science Quarterly* 44, 82-111.
- Harhoff, D., 1996, Strategic spillovers and incentives for research and development, *Management Science*. 42(6), 907-925
- Harhoff, D., Scherer, F.M., Vopel, K., 1997, Exploring the tail of patented invention value distributions, Discussion Paper FS-IV-97-27, Wissenschaftszentrum Berlin.
- Henderson, R.M., Cockburn, I., 1996, Scale, scope and spillovers: the determinants of research productivity in drug discovery, *RAND Journal of Economics* 27 (1), 32-59.
- Hicks, D.M., 1996, A morphology of Japanese and European corporate research networks, *Research Policy* 25, 359-378.
- Hounshell, D.A., 1996, The evolution of industrial research in the United States, chapter 1 in Rosenbloom, R.S. and Spencer, W.J., eds., *Engines of Innovation*, Harvard Business School Press, Boston.
- Jackson, Tim (1997), *Inside Intel*, Dutton Books, New York.
- Jaffe, A.B., 1986, Technological opportunity and spillovers of R&D: evidence from firms' patents profits and market value, *American Economic Review* 76 (5), 984-1001.
- Jaffe, A.B., Trajtenberg, M., Henderson, R., 1993, Geographic localization of knowledge spillovers as evidenced by patent citations, *Quarterly Journal of Economics* 108(3), 577-598.

- Jelinek, M., Schoonhoven, C.B., 1990, *The Innovation Marathon: Lessons from High technology Firms*, Basil Blackwell, Cambridge, MA.
- Jewkes, J., Sawers, D., Stillerman, R., 1958, *The Sources of Invention*, Macmillan and Company, London.
- Judd, C.M., Smith, E.R., Kidder, L.H. (1991), *Research Methods in Social Relations*, sixth edition, Harcourt Brace Jovanoich, Florida.
- Kim, L., 1997, The dynamics of Samsung's technological learning in semiconductors, *California Management Review* 39(3), 86-100.
- Lane, P., Lubatkin, M., 1998, Relative absorptive capacity and interorganizational learning, *Strategic Management Journal* 19(5), 461-477.
- Leonard-Barton, D., 1995, *Wellsprings of Knowledge*, Harvard Business School Press, Boston.
- Levin, R.C., Klevorick, A.K., Nelson, R.R., Winter, S.G., 1987, Appropriating the returns from industrial research and development, *Brookings Papers on Economic Activities* 3, 783-831.
- Levin, R.C., Reiss, P., 1988, Cost-reducing and demand-creating R&D with spillovers, *RAND Journal of Economics* 19 (4), 538-556.
- Liebeskind, J.P., Oliver, A.M., Zucker, L., Brewer, M., 1996, Social networks, learning and flexibility: sourcing scientific talent in new biotechnology firms, *Organization Science* 7(4), 428-443.
- Mansfield, E., 1981, Composition of R&D expenditures: relationship to size of firm, concentration, and innovative output, *Review of Economics and Statistics* 63 (4), 610-615.
- Mansfield, E., 1985, How rapidly does new industrial technology leak out?, *Journal of Industrial Economics* 34, 217-223.
- Mansfield, E., 1991, Academic Research and Industrial Innovation, *Research Policy* 20, 1-12.
- Martin, B.R., Irvine, J., 1983, Assessing basic research, *Research Policy* 12, 61-90.
- Merton, R., 1973, *The Sociology of Science: Theoretical and Empirical Investigation*, University of Chicago Press, Chicago.
- Moore, G., 1996, Some personal perspectives on research in the semiconductor industry, in *Engines of Innovation*, Rosenbloom, R. and Spencer W., eds., Harvard Business School Press, Boston, 164-174.

- Mowery, D.C., 1983, Innovation, market structure, and government policy in the American semiconductor electronics industry, *Research Policy* 12, 183-197.
- Mowery, D.C., Rosenberg, N., 1989, *Technology and the Pursuit of Economic Growth*, Cambridge University Press, Cambridge, U.K.
- Mueller, W.F., 1962, The Origins of the Basic Inventions Underlying Du Pont's Major Product and Process Innovations 1920-1950, in *The Rate and Direction of Inventive Activity: Economic and Social Factors*, Princeton University Press, 323-358.
- Narin, F., Kimberly, S.H., Olivastro, D., 1997, The increasing link between U.S. technology and public science, *Research Policy* 26 (317-330).
- Narin, F., Rozek, R.P., 1988, Bibliometric analysis of U.S. pharmaceutical industry research performance, *Research Policy* 17, 139-154.
- National Science Board, *Science & Engineering Indicators – 1998*. Arlington, VA: National Science Foundation, 1998 (NSB 98-1).  
<http://www.nsf.gov/sbe/srs/seind98/start.htm>
- Nelson, R.R., 1959, The simple economics of basic scientific research, *Journal of Political Economy* 67 (3), 297-306.
- Nelson, R.R., 1962, The link between science and technology: the case of the transistor, in R.R. Nelson (ed.), *The Rate and Direction of Inventive Activity*, Vol. 13 of NBER Special Conference Series, Princeton University Press, NJ, 549-583.
- Nelson, R.R., Winter, S., 1982, *An Evolutionary Theory of Economic Change*, Harvard University Press, Cambridge, MA.
- Nonaka, I., 1994, A dynamic theory of organizational knowledge creation, *Organization Science* 5 (1), 14-37.
- Noyons, E.C.M, Luwel, M., Moed, H.F., 1998, Assessment of Flemish R&D in the field of information technology: a bibliometric evaluation based on publication and patent data, *Research Policy*, 27(3), 285-300.
- Patel, P., Pavitt, K., 1994, The continuing, widespread (and neglected) importance of improvements in mechanical technologies, *Research Policy* (23), 533-545.
- Pavitt, K., 1991, What makes basic research economically useful, *Research Policy* 20, 109-119.
- Polanyi, 1958, *Personal Knowledge*, Routledge & Kegan Paul, London.

- Powell, W.W., Koput, K.W., Smith-Doerr, L., 1996, Interorganizational collaboration and the locus of innovation: networks of learning in biotechnology, *Administrative Science Quarterly* 41, 116-145.
- Riordan, M., Hoddeson, L., 1997, *Crystal Fire: The Birth of the Information Age*, W.W. Norton, New York.
- Ritti, R.R., 1971, *The Engineer in the Industrial Corporation*, Columbia University Press, New York.
- Roberts, E.B., 1988, Managing invention and innovation: what we've learnt, *Research•Technology Management* 31(1).
- Romer, P.M., 1990, Endogenous Technological Change, *Journal of Political Economy* 98(5):71-102.
- Rosenberg, N., 1963, Technological change in the machine tool industry, 1840-1910, *Journal of Economic History* 23(4), 414-443.
- Rosenberg, N., 1990, Why do firms do basic research (with their own money)?, *Research Policy* 19, 165-174.
- Rothwell, R., Robertson, A.B., 1973, The role of communications in technological innovation, *Research Policy* 2, 204-225.
- Spence, M., 1984, Cost reduction, competition and industry performance, *Econometrica* 52, 101-111.
- Stephan, P.E., 1996, The economics of science, *Journal of Economic Literature* 34(3), 1199-1235.
- Stern, S., 1999, Do scientists pay to be scientists: evidence from R&D job offers, MIT and NBER Working Paper W7410, Cambridge, MA.
- Stern, S., Trajtenberg, M., 1998, Empirical implications of physician authority in pharmaceutical decisionmaking, NBER Working Paper W6851, Cambridge, MA.
- Stokes, D.E., 1997, *Pasteur's Quadrant: Basic Science and Technological Innovation*, Brookings Institution, Washington, D.C.
- Teece, D.J., 1987, Profiting from technological innovation: implications for integration, collaboration, licensing and public policy, in: D.J. Teece (Editor), *The Competitive Challenge* (Ballinger, Cambridge, MA) pp. 185-219.
- Tilton, J.E., 1971, *International Diffusion of Technology: the Case of Semiconductors*, Brookings Institution, Washington, D.C.

- Trajtenberg, M., 1990, A penny for your quotes: patent citations and the value of innovations, *RAND Journal of Economics* 21 (1), 172-187.
- Utterback, J.M., 1971, The process of innovation: a study of the origination and development of ideas for new scientific instruments, *IEEE Transactions on Engineering Management* EM-18(4), 124-131.
- Verspagen, B., 1999, Large firms and knowledge flows in the Dutch R&D system: A case study of Philips Electronics, *Technology Analysis & Strategic Management*. 11(2): 211-233.
- von Hippel, E., 1988, *The Sources of Innovation*, Oxford University Press, New York.
- von Hippel, E., 1994, Sticky information and the locus of problem solving: implications for innovation, *Management Science* 40 (4), 429-439.
- Wasserman, S., Faust, K., 1994, *Social Network Analysis*, Cambridge University Press, Cambridge, UK.
- Wilson, R.W., 1980, *Innovation, Competition and Government Policy in the Semiconductor Industry*, Lexington Books, Lexington, MA.
- Yin, R.K., 1994, *Case Study Research: Design and Methods*, second edition, Sage Publications, Thousand Oaks, CA.
- Zander, U., Kogut, B., 1995, Knowledge and the speed of the transfer and imitation of organizational capabilities: an empirical test, *Organization Science* 6(1), 76-92.
- Zucker, L.G., Darby, M.R., 1995, Virtuous circles of productivity: star bioscientists and the institutional transformation of industry, NBER Working Paper W5342, Cambridge, MA.
- Zucker, L.G., Darby, M.R., Armstrong, J., 1998, Geographically localized knowledge: spillovers or markets?, *Economic Inquiry*, 36 (1), 65-86.

### **Copper Interconnect Technology**

- 1997, Back To The Future: Copper Comes of Age, *IBM Research Magazine*, Issue 4.
- ,1998, IBM's Copper Coup, *Think-IBM's Employee Magazine*, No. 1, pp. 19-27.
- ,1998, *EETimes*, Special Focus Section on Copper Interconnects, November 30.
- ,1998, Chips: Copper Interconnect IBM PowerPC 750 Report Now Available!, *Edge: Work-Group Computing Report*, September 21

- Cataldo, A., 2000, AMD samples Athlon with copper interconnects, EETimes, April 5.
- Clarke, P., 2000, UMC joins IBM, Infineon technology axis, EETimes, January 27.
- Dagastine, G, 1998, Copper: Precious Metal, EE Times, Issue 995, February 25.
- Gutmann, R., 1999, Advanced Silicon IC Interconnect Technology and Design, IEEE Trans. Microwave Theory and Techniques 47(6), 667-674.
- Koch, P, *et al.*, 1999, Development of copper etch technology for advanced copper interconnects, Proceedings of the 1999 IEEE Advanced Semiconductor Manufacturing Conference and Workshop, 290-294.
- Lammers, D., 1997, IEDM Scrutinizes Craze over Copper Interconnections, EE Times
- Lammers, D., 1998a, Motorola and IBM Show Off SRAMs with Copper Interconnects, EETimes, June 11.
- Lammers, D., 1998b, Foundries Broaden their Reach with Process, IP Prowess, EE Times, March 12.
- Lineback, J. Robert, 1998, How Copper Could Reorder the Competitive Picture, Semiconductor Business News, May 15.
- Lineback, J., 1999, Move to Copper Picks Up Speed, But Process Still Needs Work, Semiconductor Business News, February 1.
- Liu, R., 1996, Metallization, chapter 8 in Chang, C.Y. and Sze, S.M. (Eds.), ULSI Technology, McGraw-Hill, New York.
- Liu, R, Pai, C.S., and Martinez, E., 1999, Interconnect Technology Trend for Microelectronics, Solid-State Electronics Vol. 43, pp. 1003-1009.
- Markoff, J., 2000, IBM to Show a Breakthrough in Chip Making, New York Times, April 3.
- Matsumoto, C., 1998, Struggling AMD, Motorola swap technologies, EETimes 20 July.
- McGrath, D. 1998, Intel Avoids Rush To Copper, Electronic News 44(2229), 27 July.
- Murarka, S.P., Hymes, S.W., 1995, Copper metallization for ULSI and beyond, Critical Reviews in Solid State and Material Sciences 20(2), 87-124.
- Pai, P.L. and Ting, C.H. (1989), Selective Electroless Copper for VLSI Interconnection, IEEE Electron Device Letters 10(9), 423-425.



- Park, T.H. (1998), Framework for Characterization of Copper Interconnect CMP Processes, Unpublished M.S. Thesis, MIT.
- Riordan, M., Hoddeson, L., 1997, Crystal Fire: The Birth of the Information Age, W.W. Norton, New York.
- Wilson, R., 1999, Moto combines copper metal lines, low-k dielectric, EETimes 24 May.
- Wolfe, A., 1998a, AMD working quietly on copper interconnects, EETimes, 21 May.
- Wolfe, A., 1998b, Equipment Makers Crank Up for the Copper Era”, EETimes, 29 May.
- Zuckerman, L., 1997, IBM finds key to copper-based, superfast computer chips, New York Times, September 22.