

**GREEN CHEMISTRY:  
DENSE CARBON DIOXIDE AND WATER AS ENVIRONMENTALLY  
BENIGN REACTION MEDIA**

by

Andrew J. Allen

B.S., Chemical Engineering  
Texas Tech University

Submitted to the Department of Chemical Engineering in  
Partial Fulfillment of the Requirements for the Degree of

MASTER OF SCIENCE IN CHEMICAL ENGINEERING

at the

MASSACHUSETTS INSTITUTE OF TECHNOLOGY

August 2004

© Massachusetts Institute of Technology 2004,  
All Rights Reserved

Signature of Author:

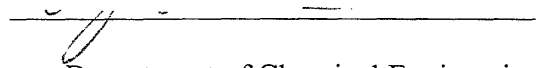
  
Department of Chemical Engineering  
August 15, 2004

Certified by:

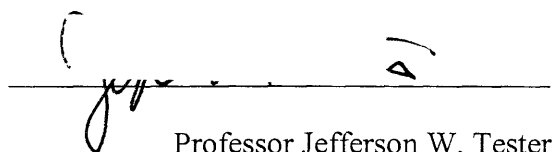
  
Professor Jefferson W. Tester  
Thesis Supervisor

Accepted by:

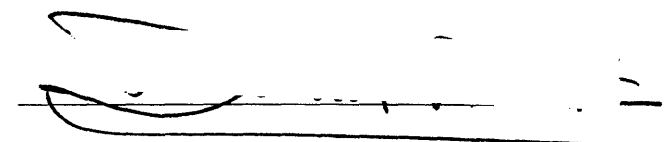
  
Daniel Blankschtein  
Professor of Chemical Engineering  
Chairman, Committee for Graduate Studies

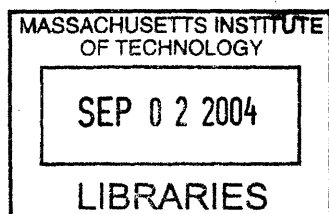

ARCHIVES

---

---

# GREEN CHEMISTRY: DENSE CARBON DIOXIDE AND WATER AS ENVIRONMENTALLY BENIGN REACTION MEDIA

by

Andrew J. Allen

To be submitted to the Department of Chemical Engineering August 2004 in partial fulfillment of the requirements for the Degree of Master of Science in Chemical Engineering

## ABSTRACT

With an ever increasing focus on reducing the environmental impact of solvent releases on human health and the environment, the replacement of conventional, organic solvents with alternative compounds that are inherently benign has attracted much attention in both industry and academia. Supercritical carbon dioxide (scCO<sub>2</sub>) and water are two alternative compounds that are of particular interest because they are non-toxic, non-flammable, readily available, and cheap. Although scCO<sub>2</sub> has been successfully used in industry as a solvent for selective extraction (e.g. extraction of caffeine from coffee beans), development of scCO<sub>2</sub> as a reaction solvent has been less successful due to its limited solvation power for many organic reagents of interest. In addition scCO<sub>2</sub> has generally been shown to reduce both the reaction rate and selectivity of many reactions when compared to conventional solvents. Unlike scCO<sub>2</sub>, water is known to significantly accelerate reaction rates and improve selectivities over that obtainable in conventional solvents. However, most organic compounds are insoluble in water which has limited its use as a reaction solvent for industrial-scale processes.

In order to replace conventional solvents with scCO<sub>2</sub> and/or water, significant technological advantages resulting from the use of these compounds will have to be demonstrated. This research attempts to demonstrate some potential advantages of using scCO<sub>2</sub> and scCO<sub>2</sub>/water as reaction media for several synthetic transformations of interest. The Diels-Alder cycloaddition of 9-hydroxymethylanthracene and N-ethylmaleimide was investigated in scCO<sub>2</sub>, and the cycloaddition between cyclopentadiene and methyl vinyl ketone (MVK) was studied in an scCO<sub>2</sub>/liquid water environment. Nitrogen chemistry, specifically the synthesis of nitrogen heterocycles from amines, was also studied in scCO<sub>2</sub> and scCO<sub>2</sub>/liquid water systems.

The objective of studying the Diels-Alder cycloaddition of 9-hydroxymethylanthracene with N-ethylmaleimide in scCO<sub>2</sub> was to demonstrate the ability of scCO<sub>2</sub> to dramatically accelerate the rate of this reaction when compared to

---

conventional solvents. Using spectroscopy to track the disappearance of the 9-hydroxymethylanthracene peak, it was found that this reaction proceeds at rates in scCO<sub>2</sub> that are significantly faster than in traditional organic solvents. It was also observed that the reaction rate constant increased with decreasing density, opposite the trend normally observed for most reactions conducted in scCO<sub>2</sub>. On the basis of the low solubility of 9-hydroxymethylanthracene in scCO<sub>2</sub> and similar results observed in fluorocarbon solvents (fluorocarbons and scCO<sub>2</sub> are known to behave similarly as solvents), a solvophobic mechanism was inferred as the cause of the rate acceleration observed for this particular reaction in scCO<sub>2</sub>.

In order to utilize the complementary solvation powers of scCO<sub>2</sub> and water, a second Diels-Alder reaction, cyclopentadiene with MVK, was studied in an scCO<sub>2</sub>/liquid water mixture. Specifically, the effect of MVK concentration on the selectivity and conversion was studied under both silent and sonicated conditions. Power ultrasound was used as a means to reduce the inherent mass transport limitations that are present in this biphasic system via the production of emulsions that increase the interfacial contact area between the two phases. The results of this study demonstrate the ability of power ultrasound to dramatically increase both the selectivity and conversion over that obtainable under silent conditions. In agreement with previous studies, it was found that the ultrasonic effect is most prevalent for systems in which the water-based Hatta number is greater than one (i.e. an initial MVK concentration of 1.0 mol L<sup>-1</sup> for this system) due to efficient utilization of the water phase. At lower Hatta numbers (or lower initial MVK concentrations) the ultrasonic effect is almost negligible as the reaction takes place mostly in the scCO<sub>2</sub> phase and not in the water phase.

The objective of the final study in this thesis was to develop amine chemistry in the presence of scCO<sub>2</sub> by identifying amines and amine derivatives suitable for application in a wide range of important synthetic transformations in carbon dioxide media. The synthesis of nitrogen heterocycles using both hetero Diels-Alder cycloadditions and Pictet-Spengler cyclizations was investigated. Also studied was carbamate formation using scCO<sub>2</sub> as both a reagent and solvent. Unfortunately, most of the results to date are less than encouraging. The hetero Diels-Alder cycloaddition between benzylamine and 2,3-dimethyl-1,3-butadiene in scCO<sub>2</sub> failed to produce a quantitative yield of the desired product; forming instead an unknown oily substance. For the Pictet-Spengler cyclization in scCO<sub>2</sub> and scCO<sub>2</sub>/water systems of N-methoxycarbonyl-3,4-dimethoxyphenethylamine, a carbamate compound, quantitative yields of the desired product were produced. However, this reaction proceeded much slower in scCO<sub>2</sub> and scCO<sub>2</sub>/water than in toluene. Due to the slow reaction rate observed in both alternative media and the inability of scCO<sub>2</sub> or water to dissolve all of the reactants, the usefulness of either scCO<sub>2</sub> or water as a reaction solvent for this Pictet-Spengler reaction is questionable. Instead an alternate “one-pot” strategy that uses scCO<sub>2</sub> as both a reactant and solvent was pursued. This strategy entails forming the carbamate from a primary amine and scCO<sub>2</sub> prior to injection of additional reagents that would allow for completion of the Pictet-Spengler reaction in the same reaction vessel. Unfortunately, attempts to replicate the methods of the Yoshida group for carbamate generation from scCO<sub>2</sub> have failed in our laboratory. We have only been able to obtain

about half the yield of the desired product achieved by Yoshida and co-workers with our remaining product mixture consisting of by-products that the Yoshida group does not find in their workup.

Thesis Supervisor:

Jefferson W. Tester  
H.P. Meissner Professor of Chemical Engineering

## ACKNOWLEDGEMENTS

There are many people who have made completion of this thesis possible and to whom I owe a debt of gratitude for the support, encouragement, kindness, and love that they have given me along the way. Special thanks and acknowledgement go to:

Professor Jeff Tester for welcoming me into his research group with open arms. Your support and guiding hand for both the completion of this thesis and in helping me decide on my next step in life are appreciated.

Professor Rick Danheiser for explaining organic chemistry concepts and providing advice on the experiments conducted in this thesis from the chemist's viewpoint.

Michael Timko and Josh Dunetz both helped introduce me to the CMI project and answered numerous questions about chemistry, reactors, and anything else that popped into my head. Mike was especially generous for showing me the ropes as he completed his thesis and for continuing to answer questions on the phone after he left our lab. Likewise, Josh was always available for any chemistry questions that I may have had. I wish him luck as he completes his thesis.

Rocco Ciccolini and Morgan Froling were quite helpful in carrying out investigations as I focused on writing my thesis. I thank them for all their help and wish them both the best of luck.

To all the members of the Tester group for lighthearted conversations that helped break the monotony of research in this dreary basement. Special thanks to Russ Lachance for answering all of my technical questions about pumps, valves, piping, etc.

I would like to thank my wonderful family, especially my mother and father, for their love and support that have helped get me to this point in life. Despite the fact that Texas is a long ways from Cambridge, it feels like you guys are right here with me.

A special thank you goes to Malancha Gupta without whom I would not be finishing this thesis. You have helped me through some tough times, and I have thoroughly enjoyed your company during the past year. I promise that I will visit quite often while I am in law school.

---

---

## ~TABLE OF CONTENTS~

<b>Chapter One: Introduction and Background .....</b>	<b>10</b>
1.1 Solvents in 'Green Chemistry' .....	10
1.2 Water and Carbon Dioxide as Benign Alternative Solvents.....	12
1.3 References.....	18
<b>Chapter Two: Objectives and Approach .....</b>	<b>22</b>
2.1 Objectives .....	22
2.2 Method of Approach.....	24
<b>Chapter Three: Solvophobic Acceleration of a Diels-Alder Reaction in                   Supercritical Carbon Dioxide .....</b>	<b>26</b>
3.1 Background and Objectives .....	26
3.2 Experimental Apparatus and Procedures .....	30
3.3 Experimental Results .....	38
3.4 Discussion.....	42
3.5 Conclusions and Recommendations .....	53
3.6 References.....	54
<b>Chapter Four: Water as a Catalyst: Conversion and Selectivity of a Model                   Diels-Alder Reaction in Carbon Dioxide/Water Systems.....</b>	<b>58</b>
4.1 Background and Objectives .....	58
4.2 Experimental Methods .....	61
4.3 Experimental Results .....	65
4.4 Conclusions.....	70
4.5 References.....	70

---

---

<b>Chapter Five: Synthesis of Nitrogen-Bearing Compounds in Dense Carbon Dioxide and/or Water Systems .....</b>	<b>72</b>
5.1 Background and Objectives .....	72
5.2 Experimental Materials and Apparatus.....	77
5.3 Hetero Diels-Alder Cycloaddition .....	79
5.4 Pictet-Spengler Cyclization .....	83
5.5 Carbamate Generation Using CO <sub>2</sub> as a Carbon Source .....	90
5.6 Conclusions and Recommendations .....	95
5.7 References.....	97
<b>Chapter Six: Conclusions and Recommendations.....</b>	<b>100</b>
<b>Chapter Seven: Appendices.....</b>	<b>106</b>
7.1 Experimental Data: Solvophobic Acceleration.....	106
7.2 Experimental Data: Diels-Alder Conversion and Selectivity .....	107

---

---

**~LIST OF FIGURES~**

<b>Figure 3-1:</b>	Simplified schematic of the high-pressure system used to obtain kinetic data in this study .....	31
<b>Figure 3-2:</b>	Digital picture of the optically-accessible, 3 mL reactor used for absorption spectroscopy.....	32
<b>Figure 3-3:</b>	Disappearance of the 379 nm peak of 9-hydroxymethylanthracene in scCO <sub>2</sub> during the course of a reaction.....	35
<b>Figure 3-4:</b>	Representative first-order plots for reaction I obtained at 75 °C in scCO <sub>2</sub> at various pressures.....	35
<b>Figure 3-5:</b>	Values of $k_c$ measured for reaction I in scCO <sub>2</sub> plotted as a function of pressure and density at various temperatures.....	40
<b>Figure 3-6:</b>	Solubility of 9-hydroxymethylanthracene in scCO <sub>2</sub> at 45 °C plotted as a function of pressure .....	42
<b>Figure 3-7:</b>	(a) Natural logarithms of $k_x$ measured for reaction I in scCO <sub>2</sub> plotted as a function of pressure. (b) $\Delta V^\ddagger$ determined from the slopes of the curves in panel (a) plotted as a function of reduced temperature .....	45
<b>Figure 3-8:</b>	Free energy sketches for reaction coordinates representing two different responses to density .....	47
<b>Figure 4-1:</b>	Schematic of the custom-built, high-pressure reactor used for sonic experiments (Timko, 2004).....	63
<b>Figure 4-2:</b>	Experimental measurements of (a) the conversion, $X$ , and (b) the selectivity, $S$ , of the Diels-Alder cycloaddition of methyl vinyl ketone with cyclopentadiene in carbon dioxide/water systems plotted versus the initial concentration of dienophile.....	67
<b>Figure 5-1:</b>	Results of work by the research groups of Leitner (left column) and Albert (right column) that demonstrate the effect of steric inhibition on carbamic acid formation from different secondary amines .....	76
<b>Figure 5-2:</b>	Digital photograph of the high-pressure view-cell reactor designed by Weinstein (1998) and used for amine chemistry studies in this work.....	78
<b>Figure 5-3:</b>	Mechanism for carbamate generation using scCO <sub>2</sub> as a carbon source for the reaction scheme described by the Yoshida group (2000).....	94



---

---

## ~LIST OF TABLES~

<b>Table 1-1:</b>	Estimated annual release and disposal of five common solvents in the United States in 1997 and 2002 (U.S. EPA).....	11
<b>Table 3-1:</b>	Rate constants, $k_c$ , measured in this study for the reaction of 9-hydroxymethylanthracene and N-ethylmaleimide in scCO <sub>2</sub> .....	39
<b>Table 3-2:</b>	Rate constants, $k_c$ , for the Diels-Alder reaction of 9-hydroxymethylanthracene and N-ethylmaleimide at 45 °C in hydrocarbon solvents, fluorocarbon solvents, water, and scCO <sub>2</sub> (Qian <i>et al.</i> , 2004).....	52
<b>Table 4-1:</b>	Characteristic values of rate related processes for dynamics of the reaction between methyl vinyl ketone and cyclopentadiene in carbon dioxide/water systems.....	68
<b>Table 5-1:</b>	Results of the hetero Diels-Alder cycloaddition in various solvents.....	81
<b>Table 5-2:</b>	Results of visual experiments aimed at determining the minimal ingredients necessary to form the unknown oil-like substance .....	82
<b>Table 5-3:</b>	Yields obtained in various solvents where formaldehyde was used as the aldehyde source for the Pictet-Spengler cyclization of carbamate .....	87
<b>Table 5-4:</b>	Conversions achieved in toluene and scCO <sub>2</sub> where benzaldehyde was used as the aldehyde source for the Pictet-Spengler cyclization of carbamate.....	87
<b>Table 5-5:</b>	Yields obtained after complete conversion of the carbamate using different aldehydes in both toluene and neat (no solvent) systems .....	89
<b>Table 5-6:</b>	Yields obtained from the carbamate generation experiments in two reactor orientations: vertical and horizontal .....	92

# CHAPTER 1

## INTRODUCTION AND BACKGROUND

### 1.1 Solvents in 'Green Chemistry'

According to the Environmental Protection Agency (EPA), which coined the term 'Green Chemistry', their early definition of the subject is: "Green Chemistry' is the utilization of a set of principles that reduces or eliminates the use or generation of hazardous substances in the design, manufacture, and application of chemical products." A key aspect of these principles is that they place more emphasis on preventing environmental problems at the early stages of innovation rather than solving problems that have already occurred (Anastas and Williamson, 1998). Investigations of chemical transformations in environmentally-friendly media could potentially lead to greener chemistry on three levels (Buelow *et al.*, 1998): 1) solvent replacement, 2) better chemistry (e.g. higher reactivity, selectivity, less energy), and 3) new chemistry (e.g. use of CO<sub>2</sub> as a carbon source).

The replacement of conventional organic solvents with more environmentally-friendly media has attracted much attention because solvents are integral to chemical practices. Solvents are used ubiquitously in a wide range of chemical industries and applications including roles in reactions, separations, extractions, and cleaning (Nelson, 2000). Worldwide the total solvent market is estimated at over 30 billion pounds per year (Nelson, 2000), but unfortunately many of these chemicals are still released in significant

quantities into the environment despite the proliferation of environmental regulations during the past three decades (Anastas and Williamson, 1998). As shown in Table 1-1, the EPA's Toxic Release Inventory (TRI) data indicates that a combined total of over 300 million pounds of methanol, toluene, xylene, methyl vinyl ketone, and acetonitrile were released and disposed of in 2002. Although the direct impact of solvent releases on human health and the environment is difficult to assess in monetary terms, the acute and chronic toxicity and the environmental persistence of many common solvents suggests a severe impact (Anastas and Williamson, 1998).

The representative reductions in solvent releases shown in Table 1-1 between 1997 and 2002 are largely a result of improvements in solvent recovery and waste stream treatment. However, the quantities released are still significant and a better long-term solution would involve a fundamental switch to cleaner solvent technologies. One solution is to eliminate the solvent, but in cases where this is not possible a second solution is the replacement of conventional organic solvents with solvents that are inherently benign.

**Table 1-1.** Estimated annual release and disposal of five common solvents in the United States in 1997 and 2002 (U.S. EPA).

<b>Solvent</b>	<b>1997 (million lbs)</b>	<b>2002 (million lbs)</b>	<b>Percentage Reduction From 1997-2002</b>
Methanol	223	167	25%
Toluene	117	65.7	44%
Xylene	77.9	43.9	44%
Methyl Ethyl Ketone	54.8	28	49%
Acetonitrile	28.4	18.6	35%

---

## 1.2 Water and Carbon Dioxide as Benign Alternative Solvents

Today there are a wide variety of solvents in industrial use with a considerable range of physical properties. Besides those listed in Table 1-1 other popular solvents include carbon disulfide, tetrahydrofuran, acetone, and dichloromethane. Because of their different properties, all of these solvents are used for many different applications including recrystallizations, extractions, cleaning, and coating among others. As a result of this solvent diversity, it is unreasonable to expect any one 'green' solvent to meet every industrial need. The motivation of this research is to investigate the use of water and/or dense carbon dioxide as environmentally benign media for the facilitation of chemical reactions. Water and carbon dioxide (specifically near- and supercritical,  $\text{scCO}_2$ ) were chosen because they are perhaps two of the most environmentally friendly solvents as they are non-toxic, non-flammable, readily available, and cheap (Timko, 2004). They were also chosen because they have been the subject of many academic investigations from which a large knowledge base can be tapped.

Water as a solvent for organic reactions was rediscovered in the eighties after a long period of time in which it was not considered due to the insolubility of most organic reactants and the incompatibility of many of the reaction intermediates with water (Lubineau *et al.*, 1994). Since the early work of both the Breslow group (Breslow *et al.*, 1983; Rideout and Breslow, 1980) and Grieco *et al.* (1984; 1983), the effect of water has been studied in a number of chemical reactions. These investigations have found that water tends to dramatically increase the rates and/or selectivities of these reactions when compared to conventional solvents due to a hydrophobic effect that is a consequence of water's unique hydrogen-bonding network (Lubineau and Auge, 1999).

Breslow and Maitra (1984) demonstrated water's ability to dramatically improve both the reaction rate and selectivity when water was used as a solvent for the Diels-Alder cycloaddition of 3-buten-2-one to cyclopentadiene:

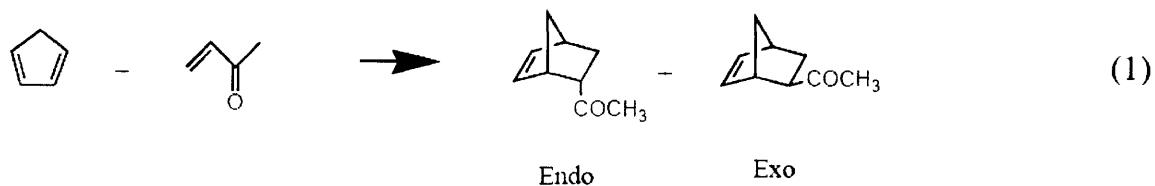

For this reaction, Breslow and Maitra found that the selectivity to the endo product was improved from 4:1 in octane to 21:1 in water. Water was also found to increase the second-order rate constant by 700-fold when compared to octane. Meanwhile, Grieco and Larsen (1986; 1985) also demonstrated water's ability to improve the rate, yield, and selectivity of a number of organic reactions including hetero Diels-Alder reactions for cyclocondensations of iminium salts.

Despite these many successes, the aforementioned poor solubility characteristics of water at moderate temperatures and pressures for most organic reagents is a serious drawback for its potential use in industry. For example, the solubility of cyclopentadiene in water at 20 °C is only 10 mM. Supercritical water is a good solvent for organic reagents, but the severe thermal condition and high pressure ( $T_c > 374$  °C,  $P_c > 240$  bar) is a major deterrent to the use of supercritical water as a solvent in many reactions of interest. Finally, two other major drawbacks for the use of water in chemical synthesis (sub- or supercritical) are many chemical processes cannot be performed in protic solvents like water and many reagents of interest will hydrolyze quickly in the presence of water (Timko, 2004).

As a gas, carbon dioxide is essentially a non-solvent, but above its critical point ( $T_c = 31.1\text{ }^\circ\text{C}$ ,  $P_c = 74\text{ bar}$ ) the solubility of many compounds in carbon dioxide increases. Unlike water, carbon dioxide's critical point is relatively mild which makes dense carbon dioxide a potentially attractive alternative solvent because it is both environmentally friendly and it has many desirable properties associated with supercritical fluids. A few of these desirable properties include the large isothermal compressibility characteristic of a near-critical fluid which allows for large changes in density via small pressure changes. In theory this ability to change the fluid density allows for manipulation of the reaction environment (solvation dynamics and equilibrium solubility) through tuning of a number of physiochemical properties including solvent power, diffusivity, and viscosity. Also, because the diffusivity and viscosity of supercritical fluids are generally at least an order of magnitude higher and lower, respectively, than liquid solvents (Lucien and Foster, 1999), interfacial transport limitations can be eliminated in principle through the use of supercritical fluids. Finally, with supercritical fluids there is the possibility of integrating both reaction and separation processes which would provide an economic advantage over conventional synthetic processes that use liquid solvents (Tester *et al.*, 2000).

Industrially, carbon dioxide (liquid, near critical, and supercritical) has been used successfully in a number of different applications because of its many advantages. Extraction of caffeine from coffee beans (McHugh and Krukonis, 1994) and the cleaning of materials with micron-sized features such as those in the microelectronics industry are a couple of example applications in which carbon dioxide has found widespread use. Carbon dioxide as a solvent is also attractive to the food and drug industries since

---

residual amounts of CO<sub>2</sub> (which should be negligible) do not have any toxic or undesirable side effects, unlike many conventional solvents.

Despite finding use in a few industrial-scale applications, the high pressures required for supercritical fluid processing are a major obstacle for more widespread industrial use of scCO<sub>2</sub>. To have an impact on industrial practice, it will be necessary to demonstrate significant technological and environmental advantages of using scCO<sub>2</sub> as a reaction solvent over conventional compounds. Unfortunately there are two major drawbacks to scCO<sub>2</sub>. Like water, the most important drawback is the low solvation power of scCO<sub>2</sub> for many reagents of interest. In general, low-molecular weight hydrocarbons, many fluorocarbons (though not highly crystalline fluorocarbons such as conventional Teflon®-type polymers) (Luna-Barcenas *et al.*, 1998), and many siloxane-based polymers (Shen *et al.*, 2003) exhibit relatively high (greater than 1 wt%) solubility in scCO<sub>2</sub> at moderate conditions. Most other compounds, including high-molecular weight hydrocarbons and ionic salts, exhibit extremely low solubilities. The example of benzene, naphthalene, and anthracene is illustrative of the relationship between molecular weight and solubility in scCO<sub>2</sub>. Benzene, the smallest compound of this trio, is almost completely miscible with scCO<sub>2</sub>. The solubility of naphthalene is roughly 5 wt% at 35 °C and 150 bar (Modell *et al.*, 1978), but at the same conditions the solubility of anthracene, the largest molecule, is less than  $5 \times 10^{-3}$  wt% (Bunker *et al.*, 1997). The second drawback to using scCO<sub>2</sub> as a solvent for reactions is that the rates and selectivities of most chemical reactions in scCO<sub>2</sub> are similar or inferior to those characteristic of reactions conducted in conventional solvents (Ikushima and Arai, 1999, Renslo *et al.*, 1997).

On an academic scale, efforts to demonstrate the technological advantages of  $\text{scCO}_2$  have focused on exploiting its physiochemical properties. Successful achievements include using its favorable transport properties to improve reaction rates, selectivities, and catalyst lifetimes for heterogeneously catalyzed transformations (Baiker, 1999; Subramaniam *et al.*, 2002). The high solubility of gases such as  $\text{H}_2$  and  $\text{CO}$  in  $\text{scCO}_2$  has been exploited in a number of hydrogenation (Burk *et al.*, 1995; Goetheer *et al.*, 2003) and hydroformylation (Davis and Erkey, 2000; Lopez-Castillo *et al.*, 2003) reactions, sometimes with substantially improved regioselectivities when compared to conventional solvents (Koch and Leitner, 1998). Near- and supercritical carbon dioxide have also been used as a reactant (Jessop *et al.*, 1996) and reversible protectant group (Wittmann *et al.*, 2001).

Without significant technological or economic advantages, environmental benefits alone are not enough to warrant the replacement of organic solvents with either carbon dioxide or water. However, one solution to overcome some of the limitations of water and carbon dioxide is to combine them. Carbon dioxide at conditions near its critical point is nearly immiscible with water (King, 1992) so that mixtures of the two naturally form a biphasic system similar to the phase splitting of hydrocarbon/water mixtures. Because the solvation powers of water and carbon dioxide are complementary, a biphasic system of the two solvents allows for dissolution of a much wider range of reagents than is possible in either solvent alone. The accelerative effect of water on chemical kinetics (the hydrophobic effect) can be accessed more readily by using carbon dioxide to dissolve the main reagents which tend to be water insoluble. Also in more sophisticated schemes, such as those involving homogeneous catalysis, segregation of the catalyst in



either one of the two phases would allow its reactivity to be accessed and allow for effective recovery of the catalyst. Despite these possible advantages not all of the limitations of water and carbon dioxide can be overcome by combining the two compounds. For instance reactions requiring an aprotic solvent still are not feasible without protecting agents, and the pH of water in contact with CO<sub>2</sub> is effectively buffered at approximately 3 (Toews *et al.*, 1995) which means that base-catalyzed reactions would require extremely aggressive buffering.

Another important limitation of a water/carbon dioxide biphasic system is the imposition of mass transport limitations upon the reaction of interest. In order to remove mass transport limitations from the water/carbon dioxide system, both emulsions (Jacobson *et al.*, 1999) and microemulsions (McCarthy *et al.*, 2002) have been investigated as a means to increase the contact area between the two phases and facilitate chemical reactions. Overall many of the results are promising as the rates and/or selectivities of some chemical reactions have been improved over that of the corresponding conventional solvent system. Most of these studies have relied upon generating emulsions through the use of surfactants designed for the water/carbon dioxide interface. However, an alternative approach that has also proven successful is the use of ultrasound to generate emulsions and thus simplify the system by eliminating the need for surfactants (Timko, 2004).

In this thesis, both carbon dioxide and carbon dioxide/water systems were investigated as reaction solvents. Their effect upon the formation of nitrogen heterocycles via iminium ions (through hetero Diels-Alder cycloadditions, Pictet-Spengler cyclizations, and dipolar cycloadditions) and their role in carbamate synthesis were

---

studied and compared to conventional solvent systems. Although many of the results of this thesis are encouraging and demonstrate the technological advantages of scCO<sub>2</sub> and water as reaction solvents, some of the experimental investigations clearly display the drawbacks of scCO<sub>2</sub> as a reaction solvent, particularly when attempting to conduct nitrogen-bearing chemistry in an scCO<sub>2</sub> environment.

### 1.3 References

- Anastas, P.T. and T.C. Williamson, "Frontiers in Green Chemistry." in *Green Chemistry: Frontiers in Benign Chemical Synthesis and Processes*, P.T. Anastas and T.C. Williamson, Eds., Oxford University Press, Oxford, **1998**.
- Baiker, A., "Supercritical Fluids in Heterogeneous Catalysis." *Chem. Rev.* **1999**, *99*, 453.
- Breslow, R. and U. Maitra, "On the Origin of Product Selectivity in Aqueous Diels-Alder Reactions." *Tetrahedron Lett.* **1984**, *25*, 1239.
- Breslow, R., U. Maitra and D. Rideout, "Selective Diels-Alder Reactions in Aqueous Solutions and Suspensions." *Tetrahedron Lett.* **1983**, *24*, 1901.
- Buelow, S., P. Dell'Orco, D. Morita, D. Pesiri, E. Birnbaum, S. Borkowsky, G. Brown, S. Feng, L. Luan, D. Morgenstern and W. Tumas, "Recent Advances in Chemistry and Chemical Processing in Dense Phase Carbon Dioxide at Los Alamos." in *Green Chemistry: Frontiers in Benign Chemical Synthesis and Processes*, P.T. Anastas and T.C. Williamson, Eds., Oxford University Press, Oxford, **1998**.
- Bunker, C.E., H.W. Rollins, J.R. Gord, and Y. Sun, "Efficient Photodimerization of Anthracene in Supercritical Carbon Dioxide." *J. Org. Chem.* **1997**, *62*, 7324.
- Burk, M.J., S. Feng, M.F. Gross and W. Tumas, "Asymmetric Catalytic Hydrogenation Reactions in Supercritical Carbon Dioxide." *J. Am. Chem. Soc.* **1995**, *117*, 8277.
- Davis, T. and C. Erkey, "Hydroformylation of Higher Olefins in Supercritical Carbon Dioxide with HRh(CO)[P(3,5-(CF<sub>3</sub>)<sub>2</sub>-C<sub>6</sub>H<sub>3</sub>)<sub>3</sub>]<sub>3</sub>." *Ind. Eng. Chem. Res.* **2000**, *39*, 3671.
- Goetheer, E.L.V., A.W. Verkerk, L.J.P. van den Broeke, E. de Wolf, B.J. Deelman, G. van Koten and J.T.F. Keurentjes, "Membrane Reactor for Homogeneous Catalysis in Supercritical Carbon Dioxide." *J. Catal.* **2003**, *219*, 126.

- 
- Grieco, P.A. and S.D. Larsen, "An Intramolecular Immonium Ion Variation of the Diels-Alder Reaction: Synthesis of ( $\pm$ )-dihydrocannivonine." *J. Org. Chem.* **1986**, *51*, 3553.
- Grieco, P. A., K. Yoshida, and Z. He, "Sodium 6-methoxy-(E,E)-3,5-hexadienoate: A Useful Diene in the Aqueous Diels-Alder Reaction." *Tetrahedron Lett.* **1984**, *25*, 5715.
- Grieco, P.A., P. Garner and Z. He, "Micellar Catalysis in the Aqueous Intermolecular Diels-Alder Reaction: Rate Acceleration and Enhanced Selectivity." *Tetrahedron Lett.* **1983**, *24*, 1897.
- Ikushima, Y. and M. Arai, "Stoichiometric Organic Reactions." in *Chemical Synthesis Using Supercritical Fluids*, P.G. Jessop and W. Leitner, Eds., Wiley VCH, New York, **1999**.
- Jacobson, G.B., C.T. Lee, R.P. daRocha and K.P. Johnston, "Organic Synthesis in Water/Carbon Dioxide Emulsions." *J. Org. Chem.* **1999**, *64*, 1207.
- Jessop, P.G., Y. Hsiao, T. Ikariya and R. Noyori, "Homogeneous Catalysis in Supercritical Fluids: Hydrogenation of Supercritical Carbon Dioxide to Formic Acid, Alkyl Formates, and Formamides." *J. Am. Chem. Soc.* **1996**, *118*, 344.
- King, M.B., A. Mubarak, J.D. Kim and T.R. Bott, "The Mutual Solubilities of Water with Supercritical Carbon Dioxide." *J. Supercrit. Fluids* **1992**, *5*, 297.
- Koch, D. and W. Leitner, "Rhodium-Catalyzed Hydroformylation in Supercritical Carbon Dioxide." *J. Am. Chem. Soc.* **1998**, *120*, 13398.
- Larsen, S.D. and P.A. Grieco, "Aza Diels-Alder Reactions in Aqueous Solution: Cyclocondensation of Dienes with Simple Iminium Salts Generated Under Mannich Conditions." *J. Am. Chem. Soc.* **1985**, *107*, 1768.
- Lopez-Castillo, Z.K., R. Flores, I. Kani, J.P. Fackler Jr. and A. Akgerman, "Evaluation of Polymer-Supported Rhodium Catalysts in 1-Octene Hydroformylation in Supercritical Carbon Dioxide." *Ind. Eng. Chem. Res.* **2003**, *42*, 3893.
- Lubineau, A. and J. Auge, "Water as a Solvent in Organic Synthesis." *Topics in Current Chemistry*, **1999**, *206*, 1.
- Lubineau, A., J. Auge and Y. Queneau, "Water-Promoted Organic Reactions." *Synthesis* **1994**, *8*, 741.
- Lucien, F.P. and N.R. Foster, "Phase Behavior and Solubility." in *Chemical Synthesis Using Supercritical Fluids*, P.G. Jessop and W. Leitner, Eds., Wiley VCH, New York, **1999**.

- 
- Luna-Barcenas, G., S. Mawson, S. Takishima, J.M. DeSimone, I.C. Sanchez and K.P. Johnston, "Phase Behavior of Poly(1,1-dihydroperfluorooctylacrylate) in Supercritical Carbon Dioxide." *Fluid Phase Equilibria* **1998**, *146*, 325.
- McCarthy, M., H. Stemmer and W. Leitner, "Catalysis in Inverted Supercritical CO<sub>2</sub>/Aqueous Biphasic Media." *Green Chem.* **2002**, *4*, 501.
- McHugh, M. A. and V.J. Krukonis, *Supercritical Fluid Extraction: Principles and Practice*. Butterworth Publishers, Stoneham, MA, **1994**.
- Modell, M., R.P. de Filippi and V.J. Krukonis, "Regeneration of Activated Carbon with Supercritical Carbon Dioxide." ACS Annual Meeting, Miami, FL, **1978**.
- Nelson, W.M, "Choosing Solvents that Promote Green Chemistry." in *Green Chemical Synthesis and Processes*, ACS Symposium Series, 767, American Chemical Society, Washington D.C., 313, **2000**.
- Renslo, A. R., R.D. Weinstein, J.W. Tester and R.L. Danheiser, "Concerning the Regiochemical Course of the Diels-Alder Reaction in Supercritical Carbon Dioxide." *J. Org. Chem.* **1997**, *62*, 4530.
- Rideout, D.C. and R. Breslow, "Hydrophobic Acceleration of Diels-Alder Reactions." *J. Am. Chem. Soc.*, **1980**, *102*, 7816.
- Shen, Z., M.A. McHugh, J. Xu, J. Belardi, S. Kilic, A. Mesiano, S. Bane, C. Karnikas, E. Beckman and R. Enick, "CO<sub>2</sub>-Solubility of Oligomers and Polymers that Contain the Carbonyl Group." *Polymer* **2003**, *44*, 1491.
- Subramaniam, B., C.J. Lyon and V. Arunajatesan, "Environmentally Benign Multiphase Catalysis With Dense Phase Carbon Dioxide." *Appl. Catal., B* **2002**, *37*, 279.
- Tester, J.W., R.L. Danheiser, R.D. Weinstein, A. Renslo, J.D. Taylor and J.I. Steinfeld, "Supercritical Fluids as Solvent Replacements in Chemical Synthesis." in *Green Chemical Synthesis and Processes*, ACS Symposium Series, 767, American Chemical Society, Washington D.C., 270, **2000**.
- Timko, M.T., "Acoustic Emulsions of Liquid, Near-Critical Carbon Dioxide and Water: Application to Synthetic Chemistry Through Reaction Engineering." Ph.D. Thesis, Department of Chemical Engineering, Massachusetts Institute of Technology, Cambridge, MA, **2004**.
- Toews, K.L., R.M. Shroll and C.M. Wai, "pH-Defining Equilibrium between Water and Supercritical CO<sub>2</sub>. Influence on SFE of Organics and Metal Chelates." *Anal. Chem.* **1995**, *67*, 4040.

---

U.S. Environmental Protection Agency, *Toxic Release Inventory*, EPA Offices of Environmental Information, **2002**.

Wittmann, K., W. Wisniewski, R. Mynott, W. Leitner, C.L. Kranemann, T. Rische, P. Eilbracht, S. Kluwer, J.M. Ernsting and C. Elsevier, "Supercritical Carbon Dioxide as Solvent and Temporary Protecting Group for Rhodium-Catalyzed Hydroaminomethylation." *Chem.-Eur. J.* **2001**, 7, 4584.

## CHAPTER 2

### OBJECTIVES AND APPROACH

#### 2.1 Objectives

The overall objective of this study was to investigate the effect of carbon dioxide and carbon dioxide/water systems on the kinetics of several different types of organic reactions. Specific objectives in obtaining knowledge about these effects were as follows:

- 1) **Investigate the solvophobic acceleration of a Diels-Alder reaction in supercritical carbon dioxide.** Most chemical transformations conducted in supercritical carbon dioxide (scCO<sub>2</sub>) display reaction rates and selectivities that are similar or inferior to those characteristic of reactions conducted in conventional solvents. These studies also indicate that the observed reaction rate increases with increasing fluid density/pressure. However, there is one known exception, that of Thompson *et al.* (1999), in which the observed reaction rates were faster than those in conventional hydrocarbon solvents and the reaction rates were also decreasing functions of fluid density/pressure. It was hypothesized that the observed behavior in the study by Thompson and co-workers was a result of solvophobic effects.

The approach of this study was to use the knowledge base developed for Diels-Alder reactions in incompressible solvents in order to gain insight regarding the molecular-level solvation effects in scCO<sub>2</sub>. Primarily, our

analysis was based on previous research that investigated the use of aqueous and fluorinated solvents as media for Diels-Alder reactions. In this study we demonstrate that the Diels-Alder cycloaddition of 9-hydroxymethylanthracene with N-ethylmaleimide in scCO<sub>2</sub> shows dramatic rate accelerations over conventional solvents and we propose that it is a solvophobic mechanism, a result of the low solubility of 9-hydroxymethylanthracene, that leads to the observed results.

- 2) Investigate the effect of a biphasic carbon dioxide/water system on the rate and selectivity of a model Diels-Alder reaction.** Combined water and carbon dioxide systems have attracted attention in green chemistry because this combination allows one to maintain the environmental benefits of aqueous reaction media while addressing the solubility limitations of organic reagents in water. Unfortunately, biphasic systems have large mass transport limitations. The generation of emulsions via the use of surfactants is one possible way to overcome these transport limitations. Another strategy is to generate emulsions through power ultrasound as demonstrated by Timko (2004). Specifically, this study continued the work of Timko by investigating the effect of initial methyl vinyl ketone concentration on the selectivity and conversion of the model Diels-Alder cycloaddition between cyclopentadiene and methyl vinyl ketone under both silent and sonicated conditions in a dense carbon dioxide/water system.
- 3) Study the chemistry of nitrogen-bearing compounds in dense carbon dioxide and/or water systems.** Chemistry of nitrogen-bearing compounds in

the presence of carbon dioxide is often difficult due to the tendency of amines to react with carbon dioxide and form carbamic acid, an undesirable, unstable side product that inhibits formation of the desired adduct. The intent of this study was to develop and investigate different reaction classes in the presence of CO<sub>2</sub> and/or water that form nitrogen heterocycles via iminium ions. Hetero Diels-Alder cycloadditions and Pictet-Spengler cyclizations were the primary reaction classes studied. Also studied was the generation of carbamate compounds using scCO<sub>2</sub> as both a reactant and solvent.

## 2.2 Method of Approach

To accomplish the above objectives, an experimental plan was developed that consisted of the following sub-projects:

- 1) Spectroscopic measurement of the reaction rate of 9-hydroxymethylanthracene with N-ethylmaleimide following the procedures previously established by Jin Qian and co-workers (2004). This measurement involved both the collection and analysis of spectroscopic data.
- 2) Design of 316-stainless steel inserts to occupy the volume of the acoustic reactor so that a water fraction of 0.85 by volume could be reached while maintaining the optimal horn-to-interface distance of 2 cm.
- 3) Measurement of the conversion and selectivity of the well-known Diels-Alder reaction between methyl vinyl ketone (MVK) and cyclopentadiene at various initial MVK concentrations in order to demonstrate the benefit of power ultrasound for a commercially important reaction.



- 4) After completion of the designated reaction time for the hetero Diels-Alder cycloaddition, Pictet-Spengler cyclization, and carbamate generation experiments, the reactor contents were collected and given to Josh Dunetz for analysis of both yields and conversions of all products and the starting material, respectively.
- 5) For the nitrogen chemistry experiments visual observations were conducted in this lab and all unexpected observations were noted and reported. For runs demonstrating unexpected behavior, control experiments were conducted as needed in order to determine the source of this behavior.

## CHAPTER 3

### SOLVOPHOBIC ACCELERATION OF A DIELS-ALDER REACTION IN SUPERCRITICAL CARBON DIOXIDE

The experiments in this study were conducted in collaboration with Jin Qian, Michael T. Timko, and Christopher J. Russell at MIT. My involvement included spectroscopically measuring the rate of the reaction of interest over a span of different pressures at 75 °C. The kinetic data at 45 °C and 60 °C and the solubility data were obtained prior to my participation in this analysis. This chapter is a summary of both my work and the work of the other collaborators involved in this study. More information can be found in publications by Qian and coauthors (2004; 2003).

#### 3.1 Background and Objectives

**Background.** Many chemical transformation reactions in supercritical fluids are under investigation by research groups in the U.S., Europe, and Japan (Tester *et al.*, 2000). The Diels-Alder cycloaddition, in particular, is a good model reaction for use in supercritical fluids because it (Timko, 2004):

- 1) is of commercial importance because it is one of the most important synthetic pathways for the construction of six-membered rings which are contained in many important pharmaceuticals and natural products.
- 2) proceeds in a controlled fashion to the desired products at low temperatures (less than 100 °C).

- 3) follows bimolecular second-order kinetics; first order with respect to each of the two reagents.
- 4) yields a mixture of isomers (either regio- or stereo-) depending on the choice of reactants, thereby affording an opportunity to study selectivity.
- 5) allows for the selection of reagents that will ensure that the reaction rates are fast enough for meaningful kinetic data to be collected in a reasonable time but slow enough to study in standard batch reactors that require reactions with half lives greater than several minutes.

Given these advantages it is not surprising that the Diels-Alder reaction has been the subject of many studies in near-critical and supercritical carbon dioxide (scCO<sub>2</sub>) (Glebov *et al.*, 2001; Thompson *et al.*, 1999; Lin and Akgerman, 1999; Renslo *et al.*, 1997; Weinstein *et al.*, 1996) and subcritical (Reaves and Roberts, 1999) and supercritical propane (Knutson *et al.*, 1995). All of these studies, with the exception of one publication (Thompson *et al.*, 1999), have found that the rates of Diels-Alder reactions are generally slower in scCO<sub>2</sub> than the rates observed in conventional hydrocarbon solvents. These studies also indicate that the observed reaction rate increases with increasing fluid density/pressure with exceptions having been reported near the critical point (Thompson *et al.*, 1999; Lin and Akgerman, 1999). Selectivities of the Diels-Alder reactions in scCO<sub>2</sub> are comparable to those observed in hydrocarbon solvents (Renslo *et al.*, 1997).

In order for scCO<sub>2</sub> to replace conventional compounds, researchers will have to demonstrate the technological advantages of using scCO<sub>2</sub> as a reaction solvent. To date most research efforts on using scCO<sub>2</sub> have focused on exploiting the physiochemical

---

properties of scCO<sub>2</sub>. One example includes taking advantage of its favorable transport properties to improve the rates, selectivities, and catalyst lifetimes of heterogeneously catalyzed transformations (Subramaniam *et al.*, 2002; Baiker, 1999). Due to the high solubility of gases such as H<sub>2</sub> and CO in scCO<sub>2</sub>, scCO<sub>2</sub> has also been used in hydrogenation (Goetheer *et al.*, 2003; Burk *et al.*, 1995) and hydroformylation (Lopez-Castillo *et al.*, 2003; Davis and Erkey, 2000; Koch and Leitner, 1998) reactions to obtain substantially improved regioselectivities when compared to conventional solvents (Koch and Leitner, 1998). Carbon dioxide has also been used as a reactant (Jessop *et al.*, 1996) and reversible protecting group (Wittmann *et al.*, 2001) at conditions near or above its critical point. Less emphasis, however, has been placed on molecular-level analysis of solvation effects of scCO<sub>2</sub> on chemical kinetics. Many of the studies of scCO<sub>2</sub> as a reaction solvent have involved catalyzed systems (Goetheer *et al.*, 2003; Lopez-Castillo *et al.*, 2003; Wittmann *et al.*, 2001; Davis and Erkey, 2000; Koch and Leitner, 1998; Jessop *et al.*, 1996; Burk *et al.*, 1995) which are difficult to interpret at a molecular level because they proceed via complex mechanisms. Meanwhile, previous attempts to predict or correlate trends for elementary reactions such as the Diels-Alder cycloaddition have relied upon kinetic- (Weinstein *et al.*, 1996) or thermodynamic- (Thompson *et al.*, 1999; Reaves and Roberts, 1999; Knutson *et al.*, 1995) fitted parameters without the benefit of molecular-level analysis.

The approach of this study was to use the knowledge base developed for Diels-Alder reactions in incompressible liquid solvents (e.g., hydrocarbons, fluorocarbons, water) in order to gain insight regarding the molecular-level solvation effects in scCO<sub>2</sub>. Primarily, our analysis was based on previous research that investigated the use of

---

aqueous and fluorinated solvents because observations of rate and selectivity improvements in these solvents are directly relevant to chemical reactivity in supercritical fluids. More specifically, since  $\text{scCO}_2$  and fluorinated compounds behave similarly as solvents, accelerative mechanisms in one may be operative in the other. If this assumption holds, then the considerable literature of Diels-Alder reactions in conventional, liquid solvents can be used to interpret observations made in supercritical fluids and to form a basis for selecting model reactions.

Since the work of Breslow and co-workers (1984; Rideout and Breslow, 1980) and Grieco *et al.* (1983), it has been well established that water dramatically improves the reaction rates and sometimes the selectivities of certain Diels-Alder reactions when compared to hydrocarbon solvents. Solvophobic interactions and an enhanced hydrogen-bonding effect, which preferentially stabilizes the polarized transition state, are considered the primary contributors to this rate enhancement (Otto and Engberts, 2000). Recent research has focused on quantifying the relative energetic contributions of these two effects for a given set of reactants through the use of computer simulations (Chandrasekhar *et al.*, 2002).

Fluorinated solvents have also been shown to accelerate certain organic reactions including Diels-Alder cycloadditions (Jenner and Gacem, 2003; Myers and Kumar, 2000), conjugate addition of amines (Jenner and Gacem, 2003), and esterification of acids and alcohols (Gacem and Jenner, 2003). One of the largest rate improvements is the 50-fold acceleration of the Diels-Alder reaction of 9-hydroxymethylanthracene (diene) and N-ethylmaleimide (dienophile) when carried out in perfluorohexane rather than acetonitrile (Myers and Kumar, 2000). Because of the inability of perfluorohexane and

acetonitrile to form hydrogen bonds, it has been hypothesized that the origin of the acceleration in perfluorohexane is entirely solvophobic.

**Objectives.** The objectives of this phase of our research project was to (1) demonstrate that the Diels-Alder cycloaddition of 9-hydroxymethylantracene and N-ethylmaleimide (reaction I) in scCO<sub>2</sub> shows dramatic rate accelerations over conventional solvents and (2) to understand the mechanism(s) responsible for this acceleration.

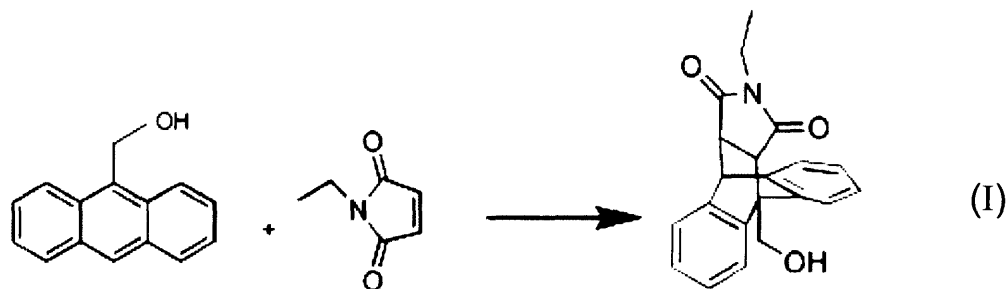

### 3.2 Experimental Apparatus and Procedures

**Materials.** 9-hydroxymethylantracene, N-ethylmaleimide, and all solvents (HPLC-grade) were purchased from Sigma Aldrich and used without further purification. Grade 5.5 carbon dioxide (>99.99%) was obtained from BOC and used as received. Water was deionized to a minimum resistivity of 18.1 M $\Omega$  cm using a Barnstead Nanopure filtration system.

**Kinetic Measurements.** The simplified experimental setup for the high-pressure experiments performed in this study is shown in Figure 3-1. Reactions were performed in an optically accessible reactor, Figure 3-2, designed previously in our research group (Taylor, 2001). This 316-stainless-steel reactor is cylindrical with a working volume of approximately 3 cm<sup>3</sup>. Sapphire ( $\alpha$ -Al<sub>2</sub>O<sub>3</sub>) windows positioned at opposing ends of the reactor (path length of 2.9 cm) were used for optical access and absorption spectroscopy.

Although the reaction mixture could be stirred with a standard Teflon-coated stir bar, a stir bar was only used in select experiments to confirm that diffusion and free convection alone were sufficient for good mixing over the time scales of interest because it was found that the stir bar interfered with spectroscopic measurements. Temperature within the reactor was monitored to within  $\pm 0.5$  °C with a T-type thermocouple inserted into the reaction fluid and maintained using a combination of a PID controller (Omega 9001CN),

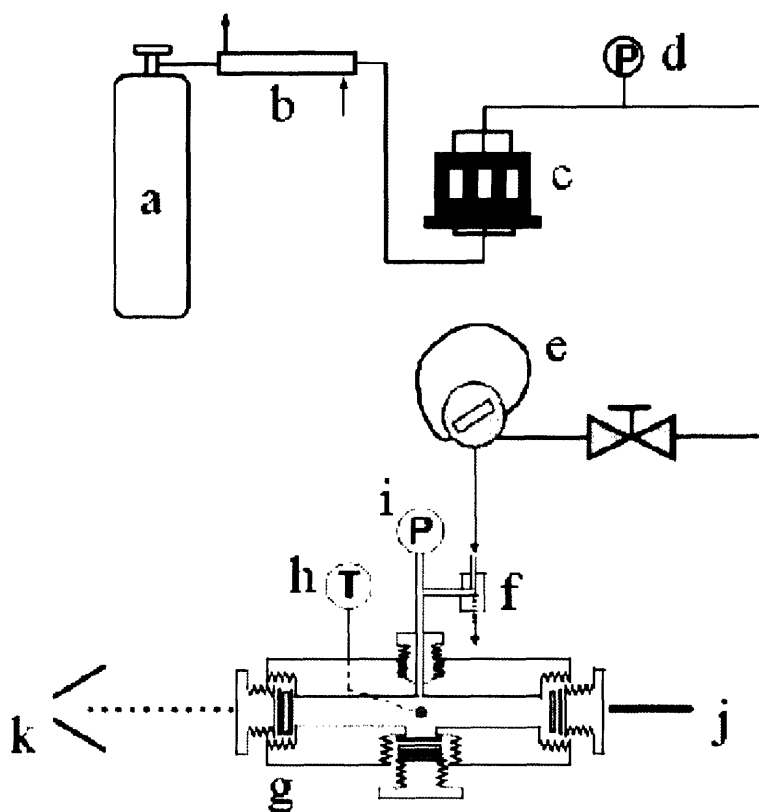

**Figure 3-1.** Simplified schematic of the high-pressure system used to obtain kinetic data in this study. Depicted are (a) cylinder of grade 5.5 CO<sub>2</sub>, (b) heat exchanger to liquefy the gaseous CO<sub>2</sub>, (c) high-pressure pump (Eldex BBB-4), (d) digital pressure transducer (Dynisco), (e) HPLC valve (Valco Instruments uw-type), (f) three-way valve that served as reactor inlet and outlet, (g) high-pressure reactor equipped with  $\alpha$ -Al<sub>2</sub>O<sub>3</sub> sapphire windows for either transmission or scattering spectroscopy, (h) T-type thermocouple, (i) analog pressure gauge (Matheson 63-3133), (j) source of monochromatic UV radiation, and (k) spectrophotometer detector.

thermal tape (Barnstead), and fiberglass insulating tape. Pressure was measured to within  $\pm 1$  bar using a standard Bourdon-tube pressure gauge (Matheson 63-3133).

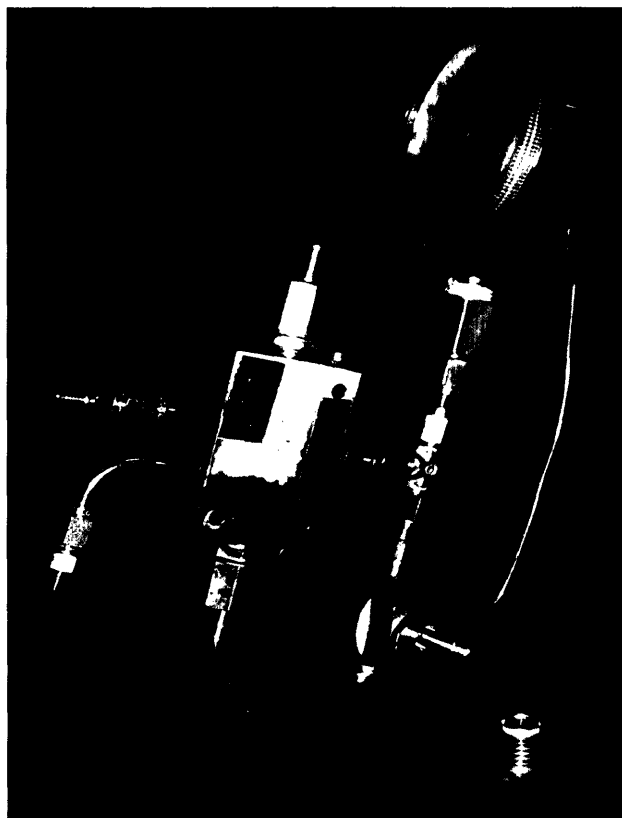

**Figure 3-2.** Digital picture of the optically-accessible, 3 mL reactor used for absorption spectroscopy. This reactor was designed previously in our research group (Taylor, 2001).

In order to initiate each reaction a solution injection method was used because both N-ethylmaleimide and 9-hydroxymethylanthracene are solids at room temperature and dissolve slowly into  $scCO_2$ . This method involved dissolving both reactants into either acetonitrile or acetone and using pressurized  $CO_2$  to inject the solution into the reactor through an HPLC valve (Valco Instruments Co. Inc. uw-type). A second injection method was used for most of the 75 °C runs in which 10  $\mu L$  of a solution of both reagents in either acetone or acetonitrile was directly injected into the reactor prior to sealing the



---

reactor cap at a torque of 100 ft-lbs. This method was adopted because of injection difficulties, likely a result of a plugged injection loop, that were encountered during the 75 °C experiments.

Visual inspection of the reactor contents indicated one-phase behavior for all experiments. However, it is sometimes difficult to visually identify the presence of a small volume of a second phase. Variation of the reactant concentrations served to confirm that if an undetected second phase were present it did not appreciably affect kinetic rate measurements. For most of the experimental runs the concentrations of N-ethylmaleimide and 9-hydroxymethylanthracene were  $1 \times 10^{-3} \text{ mol L}^{-1}$  ( $1.0 \times 10^{-4}$  mole fraction at a fluid density of  $0.4 \text{ g cm}^{-3}$ ) and  $0.02 \text{ mol L}^{-1}$  ( $2.2 \times 10^{-6}$  mole fraction at a fluid density of  $0.4 \text{ g cm}^{-3}$ ), respectively. Although the ratio of dienophile to diene was varied, it was always kept above 50:1 (in molar units) to ensure pseudo-first-order kinetics. The mole percentage of co-solvent was approximately 0.2% for most experiments and it was always less than 3.5%. Changing neither the co-solvent (acetonitrile or acetone) nor its concentration had a significant effect on the observed reaction rate within the limits of experimental reproducibility ( $\pm 5\%$ ).

For these studies the reaction temperature was varied from 45 to 75 °C and pressure was varied between 90 and 190 bar. Assuming that the reaction mixture can be treated as pure carbon dioxide, these conditions correspond to a carbon dioxide density ranging between 340 and 730  $\text{kg m}^{-3}$  as calculated by an accurate equation of state (Span and Wagner, 1996). The error introduced by assuming that the reaction mixture is pure carbon dioxide is minimal given the dilute concentrations of reactants and co-solvent used in these experiments.

---

The rate of reaction I was measured *in situ* by monitoring the disappearance of the 9-hydroxymethylanthracene peak at 379 nm using a Varian Cary 50 UV/vis spectrophotometer. At this wavelength, interference from the sapphire windows and the other chemical compounds in the reaction mixture was negligible. Reaction progress was monitored on the order of 10 h which is approximately 1 to 4 half lives depending on reaction conditions. Spectra from a representative run are presented in Figure 3-3 while several representative first-order plots of the logarithm of 9-hydroxymethylanthracene disappearance over time are shown in Figure 3-4. These logarithmic plots were always linear with little scatter and the uncertainties in the slopes were less than  $\pm 4\%$ . The second-order rate constant was calculated by dividing the slope of the assumed first-order plot by the known concentration ( $\pm 2\%$  on the basis of its post-reaction recovery) of the excess dienophile. Control experiments were conducted in which only one of two reactants was injected into the reactor in order to confirm that the compounds were stable at the conditions of interest and did not adsorb appreciably to the reactor walls. Drift in the 379 nm peak of 9-hydroxymethylanthracene was found to be less than  $\pm 2\%$ . On the basis of these three sources of error (scatter in pseudo-first-order plots, reactant adsorption, and uncertainty in the concentration of excess dienophile), the error in the measured rate constants is estimated to be less than  $\pm 10\%$ .

**Analytical Methods.** The adduct in the reaction was identified offline by reversed-phase high-performance liquid chromatography (HPLC; Waters 2690) with tandem mass spectroscopic (MS/MS; LCQ, Finnigan) detection utilizing an atmospheric pressure chemical ionization interface. A Zorbax SB-C18 column (4.6 mm x 15 cm) was used with flash column chromatography (25% ethyl acetate/hexanes). A sample volume of

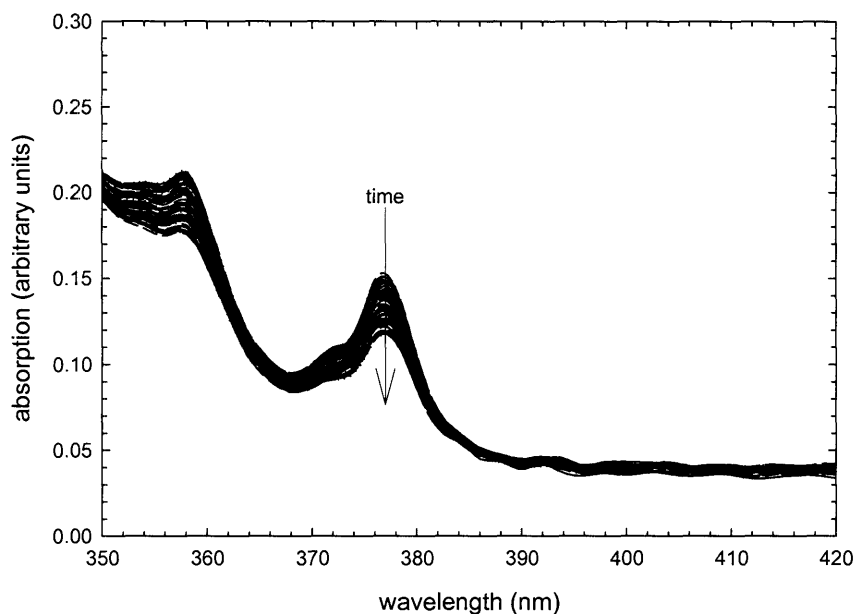

**Figure 3-3.** Disappearance of the 379 nm peak of 9-hydroxymethylanthracene in scCO<sub>2</sub> during the course of a reaction. Conditions: 75 °C, 149 bar ( $\rho = 460 \text{ kg m}^{-3}$ ). Spectra every 4 min are shown for the first hour of a 3 h long run.

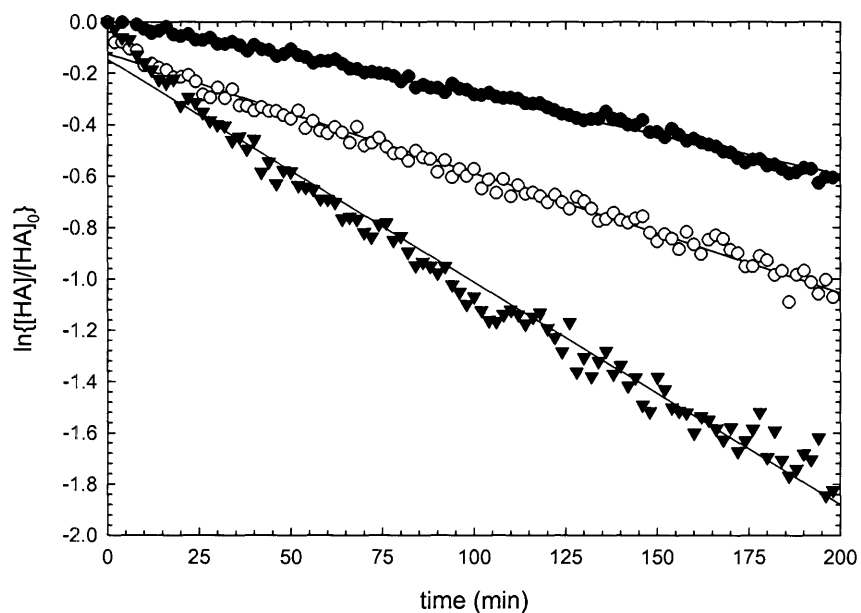

**Figure 3-4.** Representative first-order plots for reaction I obtained at 75 °C in scCO<sub>2</sub> at various pressures:  $\blacktriangledown$ , 125 bar;  $\bullet$ , 149 bar;  $\circ$ , 169 bar. [HA] is the instantaneous concentration of 9-hydroxymethylanthracene and [HA]<sub>0</sub> is its initial concentration. Solid lines are the best fits for the data, and the slopes were used to calculate the true second-order rate constant using the known concentration of excess dienophile.

---

50  $\mu\text{L}$  was injected for each analysis. The composition of the binary isocratic mobile phase was 0.499 acetonitrile/0.499 water/0.002 formic acid. Operating parameters of the MS/MS system were first auto-optimized in full scan mode and then manually adjusted by flow injection analysis of each target compound at a concentration of 1  $\text{mg L}^{-1}$ . Target compounds were identified in both full scan mode and selected ion monitoring (SIM) mode by infusion by matching the retention times and mass spectra with standards. The adduct was synthesized by refluxing *N*-ethylmaleimide and 9-hydroxymethylanthracene in a 9:1  $\text{CHCl}_3/\text{CH}_3\text{OH}$  solution for 24 h.

For several representative kinetic runs conducted in  $\text{scCO}_2$ , the reactor contents were collected by depressurizing the reaction mixture through cold acetonitrile. These post-reaction mixtures were analyzed using the HPLC-MS/MS technique, which indicated that mass balance closure of the diene was greater than 85% and that the only product was the Diels-Alder adduct of reaction I.

**Solubility Measurements.** Measurements of the solubility of 9-hydroxymethylanthracene in  $\text{scCO}_2$  at 45  $^\circ\text{C}$  and pressures ranging between 70 and 150 bar were performed by measuring the UV absorbance (at 379 nm using the Varian spectrophotometer) of samples withdrawn from the reactor. This procedure involved loading approximately 4 mg of solid 9-hydroxymethylanthracene into a 25 mL high-pressure view cell reactor which is described in detail in Chapter 5. At each pressure, the supercritical solution was stirred vigorously for 1 h and allowed to settle, unstirred, for 2 h prior to sample collection. A fraction of the mixture (between 10 and 50  $\mu\text{L}$ ) was then withdrawn through an HPLC valve (Valco Instruments uw-type) and slowly discharged into cold solvent. The precipitated 9-hydroxymethylanthracene was washed from the loop

---

with additional cold solvent and diluted to a standard volume prior to spectroscopic analysis.

**Kinetic Measurements at Atmospheric Pressure.** The rate of the Diels-Alder reaction of *N*-ethylmaleimide with 9-hydroxymethylanthracene was measured at atmospheric pressure in water and acetonitrile over the temperature range 20-50 °C. An Agilent 8532 spectrophotometer equipped with an internal stirring motor and a Peltier heater was used for the measurements. A 100-fold excess of dienophile was used in all experiments, and the initial concentration of 9-hydroxymethylanthracene was  $1 \times 10^{-3}$  mol L<sup>-1</sup> for experiments conducted in acetonitrile and  $2 \times 10^{-5}$  mol L<sup>-1</sup> for experiments conducted in water. The disappearance of diene was monitored at 379 nm for at least 2 half lives. Assumed first-order plots were linear, and the uncertainties in the slopes were less than 1%. The bimolecular rate constant was recovered by dividing the pseudo-first-order slopes by the known concentration of *N*-ethylmaleimide. For the water measurements, concentrated solutions of 9-hydroxymethylanthracene in acetonitrile were used to deliver the diene. The resulting concentration of acetonitrile was less than 1% on a mole basis.

### 3.3 Experimental Results

**Measured Rate Constants.** All 23 measured rate constants (which are referred to as  $k_c$  when reported in molar units) for reaction I in scCO<sub>2</sub> are listed in Table 3-1 together with the conditions of the experiment (pressure, temperature, density). As stated previously the density was determined using an EOS for pure carbon dioxide (Span and Wagner, 1996) and the error was estimated from the known uncertainties of the pressure and temperature measurements. At 45 °C and 90 bar, our results indicate that the reaction rate measured in scCO<sub>2</sub> is nearly 25x faster than that measured in acetonitrile at 45 °C and atmospheric pressure (Myers and Kumar, 2000; Rideout and Breslow, 1980). Considering that other Diels-Alder reactions, such as that between cyclopentadiene and ethyl acrylate, are slower in scCO<sub>2</sub> than in many conventional solvents such as methyl chloride, tetrahydrofuran, and hexane (Weinstein *et al.*, 1996), this dramatic rate acceleration is quite remarkable and it demonstrates that scCO<sub>2</sub> as a reaction solvent can provide significant technological advantages in addition to its many environmentally friendly characteristics.

**Table 3-1.** Rate constants,  $k_c$ , measured in this study for the reaction of 9-hydroxymethylanthracene and N-ethylmaleimide in scCO<sub>2</sub>. Reaction conditions are listed along with the rate data.

Run Number	$k_c$ ( $10^3 \text{ L mol}^{-1} \text{ s}^{-1}$ ) <sup>a</sup>	T (°C)	P (bar)	$\rho$ ( $\text{kg m}^{-3}$ )
1	25	45	90	340±20
2	23	45	93	380±20
3	21	45	97	440± 4
4	18	45	101	520±30
5	15	45	105	560±20
6	12	45	110	610±20
7	8.0	45	131	698± 8
8	9.6	45	135	710± 8
9	6.8	45	138	717± 7
10	7.4	45	143	729± 7
11	85	60	85	340±13
12	94	60	115	400±20
13	64	60	132	520±14
14	30	60	152	614±10
15	37	60	161	642± 7
16	24	60	166	655± 7
17	24	60	178	684± 6
18	290	75	128	352± 8
19	230	75	138	406± 9
20	120	75	152	472±30
21	110	75	169	540± 8
22	76	75	179	572± 7
23	70	75	193	610±22

<sup>a</sup> Errors in the measured rate constants are estimated to be less than 10% based on the uncertainties in the concentration of N-ethylmaleimide, errors in the spectroscopic technique, and adsorption of 9-hydroxymethylanthracene to the reactor walls.

Figure 3-5a contains a plot of  $k_c$  as a function of pressure at a given temperature while Figure 3-5b is an analogous plot of  $k_c$  versus the reaction mixture density. These plots show that at each temperature, the rate constants are roughly linear functions of pressure and density and the rate constants clearly decrease with both pressure and density. Also, the magnitudes of the slopes of  $k_c$  versus either pressure or density increase smoothly with temperature above the critical point of pure carbon dioxide.

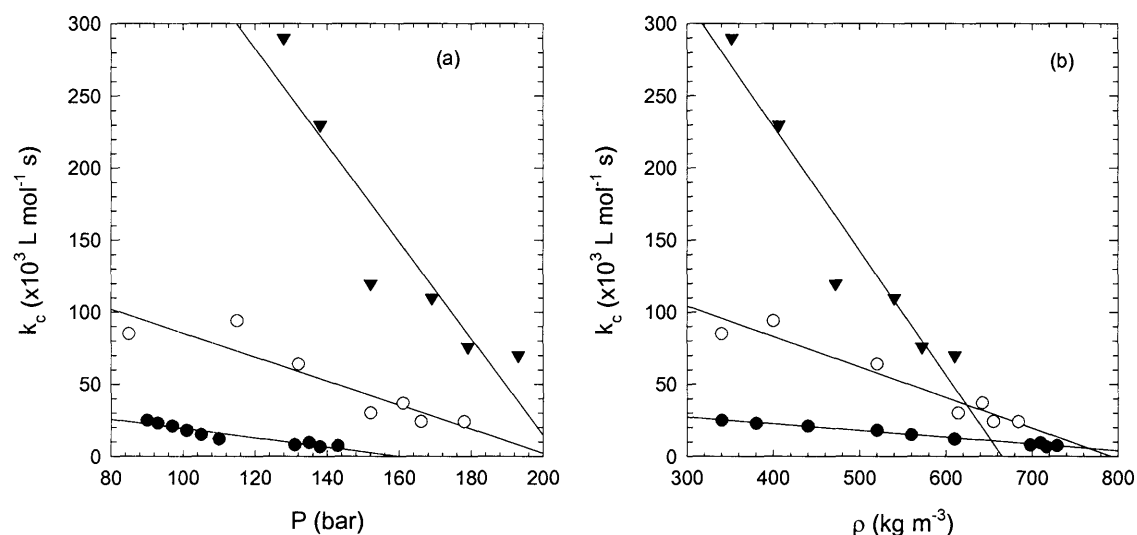

**Figures 3-5.** Values of  $k_c$  measured for reaction I in scCO<sub>2</sub> plotted as a function of pressure (a) and density (b), respectively, at various temperatures: ●, 45 °C; ○, 60 °C; ▼, 75 °C. Solid lines are the best fits for the data but have no physical basis.

To our knowledge the only published report of decreasing rate constants with increasing pressure/density for a Diels-Alder reaction in scCO<sub>2</sub> is that of Thompson *et al.* (1999). These authors studied the hetero Diels-Alder reaction of anthracene and 4-phenyl-1,2,4-triazoline-3,5-dione at 40 °C (reaction II) which is quite similar to the model reaction (reaction I) chosen for this study. Therefore, it is not entirely surprising that the two reactions exhibit similar behavior with pressure and density.



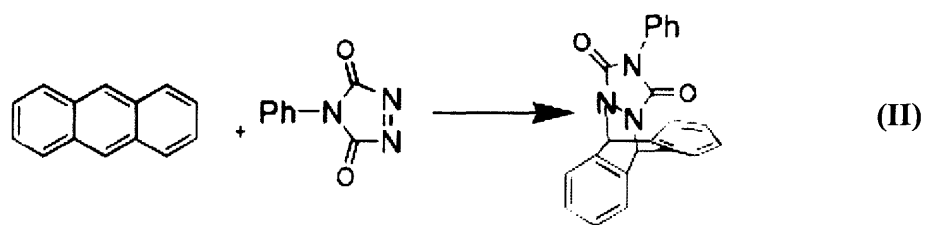

**Solubilities of 9-Hydroxymethylantracene in scCO<sub>2</sub>.** The measured solubilities of 9-hydroxymethylantracene in scCO<sub>2</sub> at 45 °C are plotted in Figure 3-6. As shown, the solubility increases from  $1.2 \times 10^{-5}$  to  $1.9 \times 10^{-4}$  mol L<sup>-1</sup> for the pressure range between 70 and 150 bar. Near 75 bar there is a sharp increase in the solubility that is related to the significant density increase in the vicinity of the critical point of scCO<sub>2</sub>. The solubility of 9-hydroxymethylantracene follows a trend similar to that observed for anthracene (Bunker *et al.*, 1997). Anthracene is roughly 10x less soluble in scCO<sub>2</sub> than 9-hydroxymethylantracene which can be attributed to two factors: (1) weak specific interactions between the methanol group of 9-hydroxymethylantracene and carbon dioxide and (2) the higher vapor pressure of 9-hydroxymethylantracene relative to anthracene due to less efficient packing in the solid state.

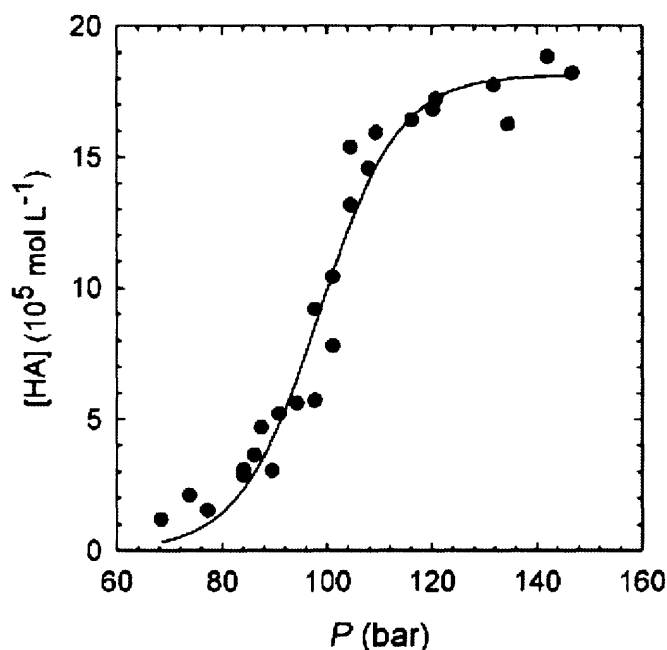

**Figure 3-6.** Solubility of 9-hydroxymethylanthracene, [HA], in scCO<sub>2</sub> at 45 °C plotted as a function of pressure. The solid line is intended to guide the eye and no physical basis is intended (Qian *et al.*, 2004).

### 3.4 Discussion

The rate of the Diels-Alder reaction of 9-hydroxymethylanthracene and *N*-ethylmaleimide is accelerated in scCO<sub>2</sub> relative to conventional solvents, and at all temperatures for which data are available, the rate constants decrease with increasing pressure/density. We propose that the solvophobic effect is the physical cause of these observations because the solvophobic mechanism is consistent with both the experimental rate and solubility measurements and it is further supported by activation volume estimates and comparison to reaction rates in conventional solvents.

**Effect of Pressure on Reaction Rates.** Transition-state theory is often used by many researchers to interpret the effect of pressure on kinetic data for reactions conducted in

---

supercritical fluids. Within this context, the pressure dependence of the rate constant is given by

$$\left(\frac{\partial \ln(k_x)}{\partial P}\right)_{T,x} = -\frac{\Delta V^\ddagger}{RT} \quad (3-1)$$

where  $k_x$  is the bimolecular rate constant expressed in mole fraction units,  $T$  and  $P$  are the system absolute temperature and pressure,  $R$  is the universal gas constant,  $x$  is the concentration in mole fraction units, and  $\Delta V^\ddagger$  is the apparent activation volume. Sometimes an overbar is used in conjunction with  $\Delta V^\ddagger$  to specify that it is a partial molar quantity. The following formula is used to convert between conventional concentration units,  $k_c$ , and mole fraction concentration units,  $k_x$ :

$$k_c = \frac{k_x}{(\rho/M_W)} \quad (3-2)$$

where  $\rho$  is the mixture fluid density (expressed as  $\text{g L}^{-1}$ ) at the temperature and pressure of the kinetic measurement and  $M_W$  is the average molecular weight of all of the species in the mixture.

The apparent activation volume is composed of two terms which account for (1) the formation/breaking of bonds and (2) changes in solvation that accompany the reaction. For both structured fluids like water and compressible fluids such as those near their critical point, the apparent activation volume is dominated by changes in the solvation volumes. Although interpretation of  $\Delta V^\ddagger$  is difficult and rarely provides mechanistic insight for complicated reactions with multiple steps, molecular-level information can be obtained in principle from interpretation of  $\Delta V^\ddagger$  for true elementary reactions such as the Diels-Alder cycloaddition.

---

Using our data and transition-state theory, Figure 3-7a is a plot of the natural logarithm of rate constants in mole fraction units (i.e.  $k_x$ ) as a function of pressure at different temperatures. The slopes of these curves are essentially linear ( $R^2 > 0.80$ ), and the lines are roughly parallel. Equation 1 was used to determine apparent values of  $\Delta V^\ddagger$ , and the results are plotted as a function of reduced temperature ( $T_r = T/T_c$ ) in Figure 3-7b. The values of  $\Delta V^\ddagger$  for the data set are both large and positive ( $+350 \text{ cm}^3 \text{ mol}^{-1}$ ), and the error bars in Figure 3-7b represent the uncertainties in the slopes of the best-fit lines in Figure 3-7a.

The studies of Jenner and Gacem (2003) on the effect of pressure on Diels-Alder reactions, report values of  $\Delta V^\ddagger$  that range from  $-27$  to  $-36 \text{ cm}^3 \text{ mol}^{-1}$ . Using these results, consideration of only the contributions from bond breaking/formation leads to  $\Delta V^\ddagger$  estimates of roughly  $-30 \text{ cm}^3 \text{ mol}^{-1}$ . Since the volume change associated with bond breaking/formation should not be strongly affected by the solvent, there must be a significant effect (roughly  $+380 \text{ cm}^3 \text{ mol}^{-1}$ ) on the apparent values of  $\Delta V^\ddagger$  measured in this study which arises from solvation.

From Figure 3-7b, proximity to the critical point has only a minimal effect on  $\Delta V^\ddagger$  since there is only a weak trend in the apparent activation volume in the range of reduced temperature, 1.06 to 1.23, considered in this study. There may be a slight increasing trend in  $\Delta V^\ddagger$  with temperature, but uncertainties in the estimated values of  $\Delta V^\ddagger$  are as large as the total change itself. This observation suggests that critical phenomena arising from density fluctuations, such as reactant clustering (either solute-solvent or solute-solute), do not play a role in the observed kinetics (Ellington and Brennecke, 1993).

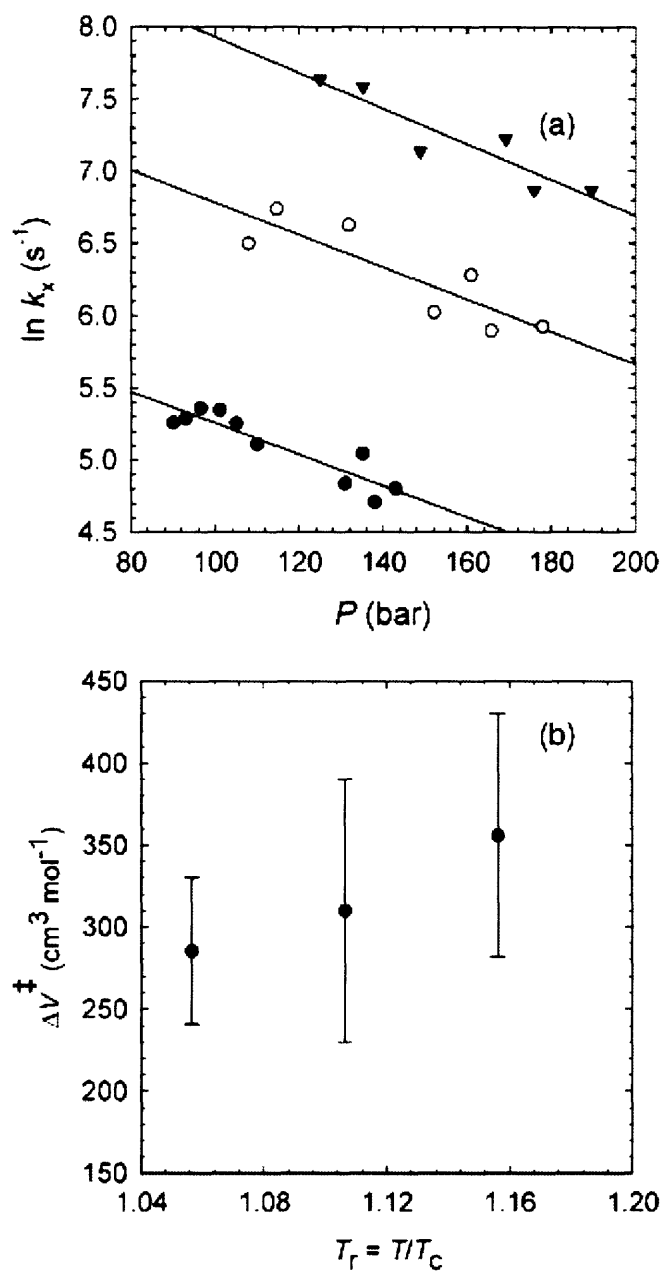
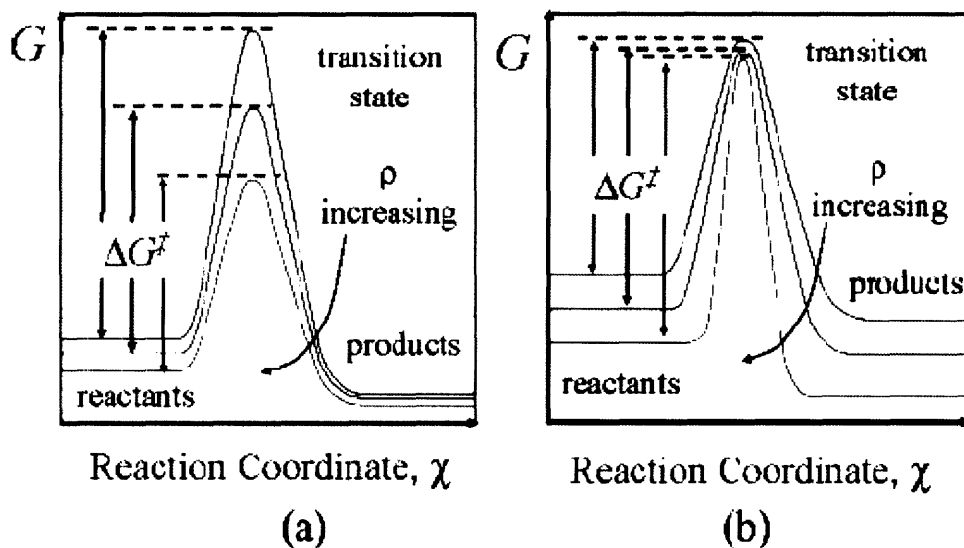

**Figure 3-7.** (a) Natural logarithms of  $k_x$  measured for reaction I in scCO<sub>2</sub> plotted as a function of pressure as suggested by equation 1: ●, 45 °C; ○, 60 °C; ▼, 75 °C. Solid lines are the best fits for the data and are related to apparent values of  $\Delta V^\ddagger$ . (b)  $\Delta V^\ddagger$  determined from the slopes of the curves in panel (a) plotted as a function of reduced temperature. Error bars are based on uncertainties in these slopes (Qian *et al.*, 2004)

---

Several researchers (Thompson *et al.*, 1999; Reaves and Roberts, 1999; Knutson *et al.*, 1995) have used cubic EOS's to predict the partial molar volume in equation 3-1, thereby relating measured rate constants (or at least trends in rate constants) to pressure. This approach usually requires estimates of  $T_c$ ,  $P_c$ , the accentricity factor ( $\omega$ ), and the binary interaction parameter ( $k_{ij}$ ) (Tester and Modell, 1997). Since thermodynamic parameters are well defined only for stable species, it is frequently assumed that the product and transition state are thermodynamically equivalent. Also, the interaction parameters are generally assumed to be zero (Thompson *et al.*, 1999; Reaves and Roberts, 1999) or small (Knutson *et al.*, 1995) compared to unity. Naturally these assumptions introduce some uncertainty and cast suspicion on the use of equation 3-1 as a predictive tool or its ability to provide physical insight. For example, Thompson *et al.* (1999) found that changing the estimated critical temperature of the product (and thus the transition state) by 20% led to entirely different signs in EOS predictions of  $\Delta V^\ddagger$ .

Due to the uncertainty and suspicions noted above, we propose a different physical picture to describe the relationship between rate constants and pressure/density in scCO<sub>2</sub> that employs a theory of preferential solvation to explain the observed reaction rate trends. Figure 3-8 is a schematic of the physical situation in terms of changes in free energy as a function of reaction coordinate,  $\chi$ . In both panels, there is an increase in free energy upon combination of the reagents to form the transition state that depicts the activation free energy for the chemical reaction,  $\Delta G^\ddagger$ . Likewise in both panels, increasing the fluid density decreases the free energy of the reagents, transition state, and product. The difference between the panels is the influence of density on the barrier height,  $\Delta G^\ddagger$ .



**Figure 3-8.** Free energy sketches for reaction coordinates representing two different responses to density. (a) shows preferential solvation of the transition state as density increases, leading to a net decrease in  $\Delta G^\ddagger$  with increasing density. In (b) the reactants are preferentially solvated by increased density, leading to a net increase in  $\Delta G^\ddagger$  as density increases (Qian *et al.*, 2004).

In Figure 3-8a, the *transition state* is preferentially solvated relative to the *reactants* ( $\Delta G^\ddagger$  is a decreasing function of density) while the *reactants* are solvated preferentially relative to the *transition state* ( $\Delta G^\ddagger$  is an increasing function of density) in Figure 3-8b. The reaction rate constant is related to  $\Delta G^\ddagger$  by the Eyring equation:

$$k_c = \frac{k_B T}{h} \exp(-\Delta G^\ddagger / RT) \quad (3-3)$$

where  $k_B$  is Boltzmann's constant ( $1.38 \times 10^{-23} \text{ J K}^{-1}$ ) and  $h$  is Planck's constant ( $6.6261 \times 10^{-34} \text{ J s}$ ). The Eyring equation simply shows that an increase in  $\Delta G^\ddagger$  leads to an exponential decrease in  $k_c$  and vice versa. As a result the Eyring equation predicts an increase in the reaction rate with density for the situation depicted in Figure 3-8a and a decrease in the reaction rate with density for the opposite situation of Figure 3-8b.

Reported kinetic rate measurements of Diels-Alder reactions in scCO<sub>2</sub> can be divided into two groups corresponding to panels (a) and (b), respectively, of Figure 3-8. The first, more populated group corresponds to Diels-Alder reactions in which the reactants are rather soluble in scCO<sub>2</sub>. Many of the most common dienes (isoprene, cyclopentadiene) and dienophiles (methyl acrylate, ethyl acrylate, maleic anhydride) in this group are either essentially miscible with scCO<sub>2</sub> or at least reasonably soluble. Of the reagents commonly used in this group, maleic anhydride is the least soluble in scCO<sub>2</sub> with a measured solubility estimated (Glebov *et al.*, 2001) to be 0.2 mol% at 60 °C and 100 bar. This contrasts with the second group, which includes the reagents used in this study and that of Thompson *et al.* (1999), in which the solubilities of the dienes are much lower, on the order of 1x10<sup>-3</sup> mol% or less.

Going beyond the physical picture described above, consideration of transition-state theory provides a more physical interpretation of the observed rate phenomena and their relationship to reagent solubility. In this context,  $k_c$  is expressed as

$$k_c = \kappa \frac{k_B T}{h} K_C^\ddagger \quad (3-4)$$

where  $\kappa$  is the transmission coefficient ( $0 \leq \kappa \leq 1$ ) and  $K_C^\ddagger$  is the concentration-based equilibrium constant for the reaction between the reactants and transition state. For an elementary reaction such as the Diels-Alder cycloaddition  $K_C^\ddagger$  is defined as

$$K_C^\ddagger = \frac{C_{A-B}^\ddagger}{C_A C_B} \quad (3-5)$$

where  $C_A$  and  $C_B$  are the molar concentrations of the reactants and  $C_{A-B}^\ddagger$  is the “concentration” of the idealized transition state. Following a standard thermodynamic



procedure, most of which can be found in the literature (Weinstein, 1998; Weinstein *et al.*, 1996), equation 3-4 can be written

$$k_x = \kappa \frac{k_B T}{h} \exp\left(\frac{-\Delta G^{\ddagger, \circ}}{RT}\right) \frac{1}{M_W} \frac{K_{x, \text{sat}}^{\ddagger}}{K_{x, \text{id}}^{\ddagger}} \quad (3-6)$$

as where  $\Delta G^{\ddagger, \circ}$  is the change in partial molar Gibbs free energy between reactants and transition state when all species are in their respective standard states,  $K_{x, \text{id}}^{\ddagger}$  is the continued product of the ideal solution mole fraction solubilities, and  $K_{x, \text{sat}}^{\ddagger}$  is the continued product of the actual saturation mole fraction solubilities. By definition  $K_{x, \text{id}}^{\ddagger}$  is not a function of pressure (Prausnitz *et al.*, 1999), and neither is  $\Delta G^{\ddagger, \circ}$  provided that the reference states are defined at a fixed pressure. Therefore, assuming that  $\kappa$  is at most a weak function of pressure, the majority of the pressure dependence in equation 3-6 is due to  $K_{x, \text{sat}}^{\ddagger}$ .

Using equation 3-6, Figure 3-8a,b can be interpreted in terms of solubility or solvation. For the Diels-Alder reactions in which the dienes are essentially miscible with scCO<sub>2</sub>, increases in fluid density will have little effect on the solubility of dienes. However, the transition state of these reactions is much less solvated in scCO<sub>2</sub> than the reactants due to the larger molecular size of the transition state. It is well-known that as the molecular size of compounds increase their solubility in scCO<sub>2</sub> decreases. This is particularly true when molecular size is increased without introduction of new functional groups. The examples of benzene (which is essentially miscible with scCO<sub>2</sub>), naphthalene (which has a characteristic solubility of approximately 5 wt% in scCO<sub>2</sub> at 35 °C and 150 bar (Modell *et al.*, 1978)), and anthracene (the solubility of which is less than 5x10<sup>-3</sup> wt% at 35 °C and 150 bar (Bunker *et al.*, 1997)) are illustrative. Unlike the

---

reactants used in these types of Diels-Alder reactions, the solvation of the large transition state, which contains no functional groups not present in the reactants, increases significantly with fluid density. Therefore,  $K_{x,sat}^\ddagger$  increases with pressure which leads to an increase in  $k_x$ .

The situation is reversed for dienes such as anthracene and 9-hydroxymethylanthracene which are sparingly soluble in scCO<sub>2</sub>. The solubilities of these reactants increase sharply with density as depicted for 9-hydroxymethylanthracene in Figure 3-6. The solvation of the transition state most likely also increases with fluid density, but we hypothesize that the effect is less pronounced than for the reactants. Therefore, for these reactions,  $K_{x,sat}^\ddagger$  decreases with pressure, leading to a decrease in  $k_x$ . This hypothesis is supported by the fact that a fraction of the insoluble surface area of the diene becomes inaccessible to the solvent during the course of the reaction. Due to the reduced requirement for solvent interactions with the transition state, it is preferentially solubilized as density is decreased. This is a solvophobic effect analogous to those reported in water (Chandrasekhar *et al.*, 2002; Otto and Engberts, 2000; Breslow *et al.*, 1984; Grieco *et al.*, 1983; Rideout and Breslow, 1980) and fluorocarbon solvents (Myers and Kumar, 2000; Jenner and Gacem, 2003). The large, positive values of  $\Delta V^\ddagger$  observed for our rate data are related to changes in the preferential solvation of the transition state relative to the reactants as pressure decreases rather than true changes in molecular volumes (of either the reactants/transition state or solvent). Critical phenomena cannot explain the observed pressure/density behavior since  $\Delta V^\ddagger$  is only a weak function of reduced temperature. In any event, solute/solute and solute/solvent clustering should be negligible for  $T_r > 1.1$  (Tucker, 1999).

---

**Solvophobic Interactions and Acceleration of Diels-Alder Reactions.** The Diels-Alder reaction between 9-hydroxymethylanthracene and *N*-ethylmaleimide has been studied previously in conventional solvents (Myers and Kumar, 2000; Rideout and Breslow, 1980). These studies have clearly implicated the accelerative roles of hydrogen-bonding and solvophobic interactions. Myers and Kumar (2000) demonstrated that the bimolecular rate constants for this reaction measured at 45 °C in a range of solvents were inversely related to the solubilities of the diene in the same solvent, with significant deviations observed only for reactions conducted in solvents capable of hydrogen bond donation (e.g., water and trifluoroethanol). Table 3-2 lists available experimental measurements of the rate constant of reaction I along with the solubility of 9-hydroxymethylanthracene and  $-\Delta\Delta G^\ddagger$ , which is the change in the activation free energy relative to that observed in acetonitrile calculated from equation 3-3. Duplicate values of  $k_c$  agree to within experimental error with the exception of those obtained in water. In this study, 1 mol% acetonitrile was used as a delivery solvent for rate studies in water. Most likely, this small amount of acetonitrile acted as a co-solvent; thus, reducing the solvophobic effect and decelerating the reaction rate.

Values of  $-\Delta\Delta G^\ddagger$  reported in Table 3-2 range from zero (for acetonitrile, by definition) to roughly 6 kJ mol<sup>-1</sup> (for water). Values of  $-\Delta\Delta G^\ddagger$  for scCO<sub>2</sub> bridge the gap between the values reported for fluorocarbon and hydrocarbon solvents. Changes in fluid density in the supercritical solvent are similar to changes in the chemical identity of incompressible solvents. Increasing the scCO<sub>2</sub> fluid density from 340 to 730 kg m<sup>-3</sup> is roughly equivalent to changing the solvent from perfluoro-*n*-butyl ether to 1-butanol. Just as in conventional solvents, the slowest rate constants are observed in scCO<sub>2</sub> under

conditions at which 9-hydroxymethylanthracene is most soluble. Naturally, the accelerative effect of scCO<sub>2</sub> is less than that of water since carbon dioxide lacks the capacity to form hydrogen bonds. Nonetheless, solvophobic reduction of  $\Delta G^\ddagger$  in scCO<sub>2</sub> is significant.

**Table 3-2.** Rate constants,  $k_c$ , for the Diels-Alder reaction of 9-hydroxymethylanthracene and N-ethylmaleimide at 45 °C in hydrocarbon solvents, fluorocarbon solvents, water, and scCO<sub>2</sub> (Qian *et al.*, 2004).

solvent	$k_c$ (10 <sup>5</sup> L mol <sup>-1</sup> s <sup>-1</sup> )	$-\Delta\Delta G^\ddagger^a$ (kJ mol <sup>-1</sup> )	solubility <sup>b</sup> (10 <sup>3</sup> mol L <sup>-1</sup> )	source
Supercritical Fluid Solvents				
scCO <sub>2</sub> ( $\rho$ = 340 g L <sup>-1</sup> )	2480±250	4.0	0.03	this work
scCO <sub>2</sub> ( $\rho$ = 560 g L <sup>-1</sup> )	1490±150	3.0	0.13	this work
scCO <sub>2</sub> ( $\rho$ = 730 g L <sup>-1</sup> )	740±100	1.8	0.18	this work
Hydrocarbon Solvents				
n-hexane	776± 80	2.3	1.24	Myers
isooctane	796± 71	2.3	na	Rideout
di- <i>n</i> -butyl ether	245± 16	0.9	20.9	
acetonitrile	108± 10	0.0	29.5	Myers
	107± 8			Rideout
	100± 6			this work
methanol	337± 60	1.3	29.9	Myers
	344± 25			Rideout
1-butanol	666± 23	2.1	na	Rideout
Fluorocarbon Solvents and Water				
perfluorohexane	5345±308	4.5	>0.005	Myers
perfluoro-2- <i>n</i> - butyl ether	4562±404	4.3	>0.005	Myers
perfluorobenzene	152± 26	0.4	11.2	Myers
trifluoroethanol	841±114	2.4	18.1	Myers
water	22300±720	6.1	0.027	Myers
	22600±700			Rideout
	18400±300			this work

<sup>a</sup> $-\Delta\Delta G^\ddagger$  is the change in activation free energy relative to that in acetonitrile. <sup>b</sup>Solubilities of 9-hydroxymethylanthracene at 45 °C where available.

---

### 3.5 Conclusions and Recommendations

The Diels-Alder reaction of *N*-ethylmaleimide with 9-hydroxymethylanthracene proceeds at rates in supercritical carbon dioxide that are much faster than in traditional organic solvents. On the basis of the low solubility of 9-hydroxymethylanthracene in scCO<sub>2</sub>, we infer a solvophobic mechanism consistent with that proposed for acceleration of this reaction in water and fluorocarbon solvents. Strong, negative pressure and density dependencies of the rate constant were observed that is consistent with a solvophobic mechanism driven by the positive relationship between fluid density and solute solubility. The apparent activation volumes are both large and positive (+350 cm<sup>3</sup> mol<sup>-1</sup>) and only a weak function of reduced temperature which rules out the influence of clustering phenomena (solute/solvent or solute/solute) as the cause of the observed accelerations. Instead, the large activation volumes can be attributed to changes in the solubility of the reagents relative to that of the transition state with increasing density.

Understanding the solvophobic acceleration of Diels-Alder reactions in scCO<sub>2</sub> provides a tool for selection of model reactions to conduct in supercritical fluids. Typically, reagent selection is based on solubility in scCO<sub>2</sub>, but our results show that solvophobic acceleration can provide a second criterion for the choice of reagents. The similarities of scCO<sub>2</sub> with fluorinated solvents (which are more accessible experimentally than scCO<sub>2</sub>) might also be exploited in the future. However, like water, scale-up of reactions involving sparingly soluble species may be prohibitive for utilizing scCO<sub>2</sub> as a solvent for Diels-Alder reactions and other syntheses.

Future work should be conducted to further understand this solvophobic acceleration so that the results uncovered by this investigation might be applied to a

---

wider range of organic reactions. Possible focal points include: (1) determination of specific molecular structures which are expected to interact solvophobicly in scCO<sub>2</sub>, (2) further quantification of the solvophobic effect, particularly in the presence of hydrogen-bond-donating co-solvents, and (3) development of computational techniques integrating methods from density functional theory and molecular simulation to further molecular-level understanding of reactivity in scCO<sub>2</sub>.

### 3.6 References

- Baiker, A., "Supercritical Fluids in Heterogeneous Catalysis." *Chem. Rev.* **1999**, *99*, 453.
- Breslow, R. and U. Maitra, "On the Origin of Product Selectivity in Aqueous Diels-Alder Reactions." *Tetrahedron Lett.* **1984**, *25*, 1239.
- Bunker, C.E., H.W. Rollins, J.R. Gord, and Y. Sun, "Efficient Photodimerization of Anthracene in Supercritical Carbon Dioxide." *J. Org. Chem.* **1997**, *62*, 7324.
- Burk, M.J., S. Feng, M.F. Gross and W. Tumas, "Asymmetric Catalytic Hydrogenation Reactions in Supercritical Carbon Dioxide." *J. Am. Chem. Soc.* **1995**, *117*, 8277.
- Chandrasekhar, J., S. Shariffskul and W.L. Jorgensen, "QM/MM Simulations for Diels-Alder Reactions in Water: Contribution of Enhanced Hydrogen Bonding at the Transition State to the Solvent Effect." *J. Phys. Chem. B* **2002**, *106*, 8078.
- Davis, T. and C. Erkey, "Hydroformylation of Higher Olefins in Supercritical Carbon Dioxide with HRh(CO)[P(3,5-(CF<sub>3</sub>)<sub>2</sub>-C<sub>6</sub>H<sub>3</sub>)<sub>3</sub>]." *Ind. Eng. Chem. Res.* **2000**, *39*, 3671.
- Ellington, J.B. and J.F. Brennecke, "Pressure Effect on the Esterification of Phthalic Anhydride in Supercritical Carbon Dioxide." *J. Chem. Soc., Chem. Commun.* **1993**, 1094.
- Gacem, B. and G. Jenner, "Esterification of Sterically Hindered Acids and Alcohols in Fluorous Media." *Tetrahedron Lett.* **2003**, *44*, 1391.
- Glebov, E.M., L.G. Krishtopa, V. Stepanov and L.N. Krasnoperov, "Kinetics of a Diels-Alder Reaction of Maleic Anhydride and Isoprene in Supercritical CO<sub>2</sub>." *J. Phys. Chem. A* **2001**, *105*, 9427.

- 
- Goetheer, E.L.V., A.W. Verkerk, L.J.P. van den Broeke, E. de Wolf, B.J. Deelman, G. van Koten and J.T.F. Keurentjes, "Membrane Reactor for Homogeneous Catalysis in Supercritical Carbon Dioxide." *J. Catal.* **2003**, *219*, 126.
- Grieco, P.A., P. Garner and Z. He, "Micellar Catalysis in the Aqueous Intermolecular Diels-Alder Reaction: Rate Acceleration and Enhanced Selectivity." *Tetrahedron Lett.* **1983**, *24*, 1897.
- Jenner, G. and B. Gacem, "High-Pressure Effect on Organic Reactions in Fluorophobic Media." *J. Phys. Org. Chem.* **2003**, *16*, 265.
- Jessop, P.G., Y. Hsiao, T. Ikariya and R. Noyori, "Homogeneous Catalysis in Supercritical Fluids: Hydrogenation of Supercritical Carbon Dioxide to Formic Acid, Alkyl Formates, and Formamides." *J. Am. Chem. Soc.* **1996**, *118*, 344.
- Knutson, B.L., A.K. Dillow, C.L. Liotta and C.A. Eckert, "Kinetics of a Diels-Alder Reaction in Supercritical Propane." in *Innovations in Supercritical Fluids*, K.W. Hutchenson and N.R. Foster, Eds., ACS Symposium Series, *608*, American Chemical Society, Washington, D.C., 166, **1995**.
- Koch, D. and W. Leitner, "Rhodium-Catalyzed Hydroformylation in Supercritical Carbon Dioxide." *J. Am. Chem. Soc.* **1998**, *120*, 13398.
- Lin, B. and A. Akgerman, "Isoprene/Methyl Acrylate Diels-Alder Reaction in Supercritical Carbon Dioxide." *Ind. Eng. Chem. Res.* **1999**, *38*, 4525.
- Lopez-Castillo, Z.K., R. Flores, I. Kani, J.P. Fackler Jr. and A. Akgerman, "Evaluation of Polymer-Supported Rhodium Catalysts in 1-Octene Hydroformylation in Supercritical Carbon Dioxide." *Ind. Eng. Chem. Res.* **2003**, *42*, 3893.
- Modell, M., R.P. de Filippi and V.J. Krukoni, "Regeneration of Activated Carbon with Supercritical Carbon Dioxide." ACS Annual Meeting, Miami, FL, **1978**.
- Myers, K.E. and K. Kumar, "Fluorophobic Acceleration of Diels-Alder Reactions." *J. Am. Chem. Soc.* **2000**, *122*, 12025.
- Otto, S. and J.B.F.N. Engberts, "Diels-Alder Reactions in Water." *Pure Appl. Chem.* **2000**, *72*, 1365.
- Prausnitz, J.M., R.N. Lichtenthaler and E. Gomes de Azevedo, *Molecular Thermodynamics of Fluid-Phase Equilibria*, 3<sup>rd</sup> ed. Prentice Hall PTR, Upper Saddle River, NJ, **1999**.
- Qian, J., M.T. Timko, A.J. Allen, C.J. Russell, B. Winnik, B. Buckley, J.I. Steinfeld and J.W. Tester, "Solvophobic Acceleration of Diels-Alder Reactions in Supercritical Carbon Dioxide." *J. Am. Chem. Soc.* **2004**, *126*, 5465.

- 
- Qian, J., M. Timko, J.W. Tester, J.I. Steinfeld, B. Winnik, B. Buckley and B. Green, "Synthetic Diels-Alder Chemistry in Liquid and Supercritical Carbon Dioxide Solvent." ACS Annual Meeting, New Orleans, LA, **2003**.
- Reaves, J.T. and C.B. Roberts, "Subcritical Solvent Effects on a Parallel Diels-Alder Reaction Network." *Ind. Eng. Chem. Res.* **1999**, *38*, 855.
- Renslo, A. R., R.D. Weinstein, J.W. Tester and R.L. Danheiser, "Concerning the Regiochemical Course of the Diels-Alder Reaction in Supercritical Carbon Dioxide." *J. Org. Chem.* **1997**, *62*, 4530.
- Rideout, D.C. and R. Breslow, "Hydrophobic Acceleration of Diels-Alder Reactions." *J. Am. Chem. Soc.*, **1980**, *102*, 7816.
- Span, R. and W. Wagner, "A New Equation of State for Carbon Dioxide Covering the Fluid Region from the Triple-Point Temperature to 1100 K at Pressures Up to 800 MPa." *J. Phys. Chem. Ref. Data* **1996**, *25*, 1509.
- Subramaniam, B., C.J. Lyon and V. Arunajatesan, "Environmentally Benign Multiphase Catalysis With Dense Phase Carbon Dioxide." *Appl. Catal., B* **2002**, *37*, 279.
- Taylor, J.D., "Hydrothermal Chemistry of Methyl Chloride and MTBE: Experimental Kinetics and Reaction Pathways." Ph.D. Thesis, Department of Chemical Engineering, Massachusetts Institute of Technology, Cambridge, MA, **2001**.
- Tester, J.W., R.L. Danheiser, R.D. Weinstein, A. Renslo, J.D. Taylor and J.I. Steinfeld, "Supercritical Fluids as Solvent Replacements in Chemical Synthesis." in *Green Chemical Synthesis and Processes*, ACS Symposium Series, 767, American Chemical Society, Washington D.C., 270, **2000**.
- Tester, J.W. and M. Modell, *Thermodynamics and its Applications*, 3<sup>rd</sup> ed. Prentice Hall PTR, Upper Saddle River, NJ, **1997**.
- Thompson, R.L., R. Glaser, D. Bush, C.L. Liotta and C.A. Eckert, "Rate Variations of a Hetero-Diels-Alder Reaction in Supercritical Fluid CO<sub>2</sub>." *Ind. Eng. Chem. Res.* **1999**, *38*, 4220.
- Timko, M.T., "Acoustic Emulsions of Liquid, Near-Critical Carbon Dioxide and Water: Application to Synthetic Chemistry Through Reaction Engineering." Ph.D. Thesis, Department of Chemical Engineering, Massachusetts Institute of Technology, Cambridge, MA, **2004**.
- Tucker, S., "Solvent Density Inhomogeneities in Supercritical Fluids." *Chem. Rev.* **1999**, *99*, 391.



Weinstein, R.W., "Organic Synthesis in Supercritical Carbon Dioxide." Ph.D. Thesis, Department of Chemical Engineering, Massachusetts Institute of Technology, Cambridge, MA, **1998**.

Weinstein, R.D., A.R. Renslo, R.L. Danheiser, J.G. Harris and J.W. Tester, "Kinetic Correlation of Diels-Alder Reactions in Supercritical Carbon Dioxide." *J. Phys. Chem.* **1996**, *100*, 12337.

Wittmann, K., W. Wisniewski, R. Mynott, W. Leitner, C.L. Kranemann, T. Rische, P. Eilbracht, S. Kluwer, J.M. Ernsting and C. Elsevier, "Supercritical Carbon Dioxide as Solvent and Temporary Protecting Group for Rhodium-Catalyzed Hydroaminomethylation." *Chem.-Eur. J.* **2001**, *7*, 4584.

## CHAPTER 4

### WATER AS A CATALYST: CONVERSION AND SELECTIVITY OF A MODEL DIELS-ALDER REACTION IN CARBON DIOXIDE/WATER SYSTEMS

This chapter describes an experimental investigation of the Diels-Alder reaction between cyclopentadiene and methyl vinyl ketone conducted in carbon dioxide/water mixtures. My contribution to this project involved studying the effect of methyl vinyl ketone concentration on the conversion and selectivity of this reaction under sonicated conditions. This work was a continuation of the experiments performed previously by Michael T. Timko in his Ph.D. thesis (2004).

#### 4.1 Background and Objectives

**Background.** As described in Chapter 1, the work of Breslow and co-workers (Breslow *et al.*, 1983; Rideout and Breslow, 1980) and Grieco *et al.* (1984; 1983) in the early 1980s sparked two decades of intense investigation into the effect of water upon the reactivity of organic compounds. Both researchers independently found that the rates of certain Diels-Alder reactions were accelerated nearly a 1000-fold when conducted in aqueous media rather than conventional hydrocarbon solvents. These results changed the common perception of water as a solvent that was not practical for important synthetic reactions (due to the limited solubility of most organic compounds) into a solvent that may be industrially useful because of its well-known environmental compatibility and recently discovered technological advantages.

A recent review by Lubineau and Auge (1999) describes many types of chemical reactions that demonstrate the advantages, both improved reaction rates and selectivities, of using water rather than conventional hydrocarbon solvents. Although the role of water in these reactions is complex and not completely understood, it is agreed that the hydrophobic effect and enhanced hydrogen bonding of water to highly polarized transition states dominate the observed accelerative effects of water on chemical kinetics. The relative contribution of these effects is the subject of current inquiry (Chandrasekhar *et al.*, 2002).

Despite successful academic research that has exhibited clear technological advantages of using water over conventional solvents, water has not yet been adopted on a commercial scale because of the limited solubility of most organic reagents in water. In effect, this limited solubility places a limit on the maximum production rates that can be achieved. There are potential engineering solutions to increase production rates but they all suffer from severe disadvantages. For example, reactors with volumes large enough to maintain required production rates while ensuring one-phase conditions could be used. However, the recovery of low concentrations of organic compounds from aqueous streams would be energy intensive and costly and the low solubilities of the organic compounds would offset any increases in the production rate achieved by using water over conventional solvents. Another solution is to deploy a second organic phase in addition to the water phase or to even use one of the reactants as a second phase. The problems with this solution are that using a second organic phase would compromise the environmental advantages of using water as a reaction solvent, and it is possible that the favorable selectivities anticipated with aqueous-based chemistry will be limited by side

reactions occurring in the organic phase (Timko, 2004). Finally, an array of chemistry-based solutions has been proposed to increase the solubility of organic compounds in water while retaining the other beneficial aspects of aqueous reactivity. These techniques include the addition of carboxylate groups to common dienes (Grieco *et al.*, 1984), the creation of glucose-grafted dienes (Lubineau *et al.*, 1994), the use of polar co-solvents (Blokzilj and Engberts, 1994), and the use of surfactants to solubilize organic reagents (Diego-Castro and Hailes, 1998). Although many of these methods have been successful, potential drawbacks include the need for additives like surfactants, limitations on the range of reagents that can be used, or an increase in the number of chemical steps required to form the desired product.

Timko (2004) pursued an alternative approach to overcome the solubility limitations of water. His approach employs a biphasic system in which dense carbon dioxide is used in conjunction with liquid water in order to maintain the environmental benefits of aqueous reaction media while addressing the solubility limitations of organic reagents. In this study the Diels-Alder cycloaddition between cyclopentadiene and methyl vinyl ketone in biphasic carbon dioxide/water systems was studied. To overcome mass transport limitations that are present in biphasic systems, power ultrasound was used to generate emulsions in order to increase the interfacial contact area between phases. Ultrasound was introduced into the reaction mixture via a titanium sonic probe that was immersed in the reaction fluid. Experiments were conducted at 30 °C and 80 bar over a range of water volume fractions with a methyl vinyl ketone concentration of 1 mol L<sup>-1</sup>. In non-emulsified, silent systems, it was found that both the selectivity and conversion (after 1 hour) increase with increasing water content. With sonication, both the conversion and

selectivity increased dramatically over the silent case. For example, sonication at a water fraction of 0.60, increased conversion from 30% to 60% and selectivity from 6.5:1 to greater than 10:1. Furthermore, the experimental results suggest that 2 cm is the optimal distance between the tip of the sonic horn and the carbon dioxide/water interface. Sonic enhancement was much less dramatic for horn-to-interface distances which differed from this optimal value, consistent with a number of published reports on the sonication of fluids (Laborde *et al.*, 2000; Dahnke and Keil, 1999; McMurray and Wilson, 1999).

**Objective.** The objective of this study was to extend our work in biphasic systems by investigating the effect of methyl vinyl ketone concentration on the selectivity and conversion of the model Diels-Alder cycloaddition between cyclopentadiene and methyl vinyl ketone (reaction 4-1):

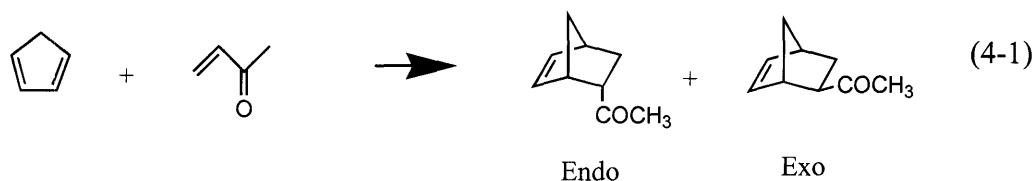

Both silent and sonicated conditions in a dense carbon dioxide/liquid water biphasic system were evaluated.

## 4.2 Experimental Methods

**Materials.** Methyl vinyl ketone (purity > 99%) and HPLC-grade acetone (purity > 99.55%) were obtained from Sigma Aldrich and used as received. Dicyclopentadiene was also purchased from Sigma Aldrich and cracked at 180 °C to obtain cyclopentadiene with a purity of roughly 98% as determined by gas chromatography. The freshly prepared cyclopentadiene was used immediately or stored at -10 °C for up to 12 hours before use. Water was deionized to a minimum resistivity of 18.1 M $\Omega$  (Barnstead Nanopure) and

---

used immediately. Grade 5.5 carbon dioxide (purity > 99.9995%) was purchased from BOC Gases and used without further treatment.

**Experimental Conditions.** All experiments were conducted in an acoustic reactor designed previously in our group for use in studies involving high-pressure, ultrasonic emulsification. This reactor is described in detail elsewhere (Timko, 2004), so only the salient features are presented here. The high-pressure reactor, as shown in Figure 4-1, consists of two intersecting cylindrical chambers (i.d. = 1.9 cm) bored in a slab (18.8 cm x 15.3 cm x 5.1 cm) of 316-stainless steel. Three of the four apertures in the reactor contain  $\alpha$ -Al<sub>2</sub>O<sub>3</sub> sapphire windows sealed with stainless steel glands. The pressure seal was made using a Teflon gasket and the sapphire itself was protected from damage during tightening by a buna-*N* rubber gasket (90 durometer, Shore A, provided by New England Die Cutting, Inc.). The fourth aperture contains a titanium sonic probe (o.d. = 0.80 cm, Sonics and Materials, Inc.) sealed with a stainless steel gland. Teflon and buna-*N* gasket were again used to make the pressure seal for this aperture. During experimental runs the glands were tightened to approximately 90 ft-lbs using a torque wrench.

The experimental conditions of this study replicate those used by Timko (2004). Reactions were run at 30 °C and 80 bar; an environment which was originally selected by Timko because the effects of ultrasound were well established under these conditions and the liquid-like density of carbon dioxide (0.70 g cm<sup>-3</sup>) at this temperature and pressure was expected to favor high solubility of the reagents and promote two-phase conditions. In addition to ultrasound, described below, a recirculation loop was also used to agitate the contents of the reactor. The recirculation loop was configured so that the water phase was recirculated through the carbon dioxide phase.

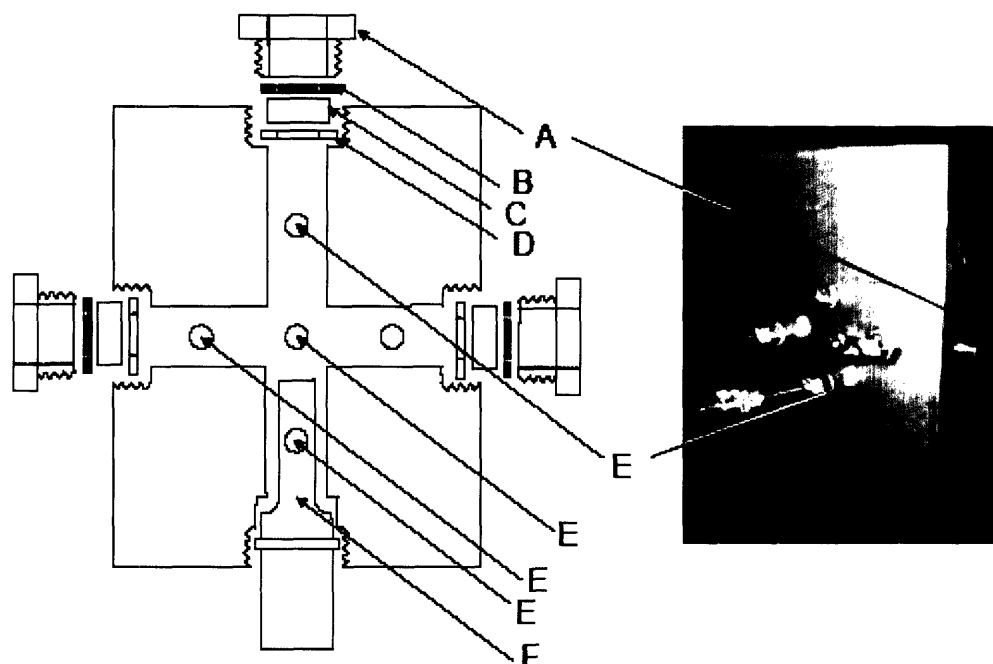

**Figure 4-1.** Schematic of the custom-built, high-pressure reactor used for sonic experiments. A: stainless steel gland; B: buna-*N* gasket; C: sapphire window; D: Teflon gasket; E: 0.25" apertures for machined NPT fittings; F: sonic probe. Pictured on the right is a digital photograph of the reactor (Timko, 2004).

Ultrasound was introduced directly into the reaction medium using the Branson sonication unit and titanium probe described previously (Timko, 2004). The operating frequency of the sonication unit is 20 kHz and the ultrasound was pulsed at a duty of 25% (based on a 1 s cycle) for reactions studied at a power density of  $0.55 \text{ W cm}^{-3}$ . Sonication experiments were only conducted with the horn inserted into the water phase and pointed up toward the carbon dioxide/water interface. For all experimental runs, the volume of the water phase was monitored so that the horn tip resided approximately 2 cm from the interface, corresponding to the optimal distance determined by Timko (2004).

**Experimental Protocol.** Selectivity and conversion after 1 hour were measured for the Diels-Alder reaction between cyclopentadiene and methyl vinyl ketone in a dense carbon

---

dioxide/water system (85% water by volume/15% CO<sub>2</sub>). Experimental runs were conducted both in the presence and absence of emulsifying ultrasound. The initial concentration of methyl vinyl ketone, [MVK]<sub>0</sub>, was varied from 0.05 to 1.0 mol L<sup>-1</sup>. Larger concentrations of [MVK]<sub>0</sub> were not used because preliminary experiments indicated three-phase behavior (water-rich liquid, dense CO<sub>2</sub>, and an MVK-rich phase) for concentrations above 1.0 mol L<sup>-1</sup> of the dienophile in water/carbon dioxide systems at 30 °C and 80 bar.

Due to the design of the acoustic reactor, a 316-stainless steel insert was designed and fabricated to occupy a portion of the reactor volume so that the experiments could be conducted with a water fraction of 0.85 while maintaining the 2 cm horn-to-interface distance. With the horn pointed up, the reactor is designed such that 55 cm<sup>3</sup> of the water phase is needed to obtain the 2 cm distance. As a result, the insert, with a volume of 17.3 cm<sup>3</sup>, was used to displace a portion of the excess CO<sub>2</sub> volume thereby reducing the total reactor volume from 82.5 ± 1.6 cm<sup>3</sup> to 65.2 ± 1.6 cm<sup>3</sup>.

In a typical run a solution of MVK and water was prepared and added to the reactor. The reactor was then sealed and pressurized to 70 bar with carbon dioxide. For 30 minutes the reactor contents were allowed to come to thermal equilibrium during which time the mixture was agitated using the recirculation pump (LDC Analytical) operating at a flow rate of 15 cm<sup>3</sup>. Sonication was also commenced at this time for experiments in which it was used. After thermal equilibrium was achieved, the pressure of the reactor was increased to 80 bar. The reaction was then initiated by injecting 50 μL of cyclopentadiene into the reactor through a calibrated sample loop via a standard 6-way valve (Valco Instruments uw-type) using the recirculating water phase.



---

The reaction was concluded after 1 hour by venting the entire reactor contents into cold acetone. A high-pressure metering valve (Autoclave Engineers 10VRMM2812) heated with thermal tape (Barnstead) operated at 40 V (as set by a standard variable transformer) was used to maintain an even flow of depressurizing carbon dioxide and prevent formation of ice in the vent line. A glass vessel equipped with a frit (10  $\mu\text{m}$  pore diameter) was used to improve recovery of volatile components. The cold acetone into which the reactor contents had been vented was diluted to a standard volume by more acetone and analyzed by GC (Agilent 6890) using the method described for the measurement of rate data in pure water in Chapter 7 of Timko (2004). The reactor was rinsed with acetone and this wash was also analyzed by GC. Uncertainties in the calculated selectivity and conversion to a 95% confidence level were based on the error in the GC calibration which was  $\pm 3\%$ .

### 4.3 Experimental Results

The results from the variable  $[\text{MVK}]_0$  experiments are presented in Figure 4-2. The silent experiments were completed prior to my analysis of the sonicated condition. Under silent conditions decreasing the initial concentration of MVK from  $1.0 \text{ mol L}^{-1}$  to  $0.05 \text{ mol L}^{-1}$  increases the selectivity from roughly 6:1 (slightly higher than the 4.4:1 observed in pure carbon dioxide) to nearly 16:1 (much closer to the 20:1 observed in pure water). Meanwhile, the selectivity is much less sensitive to  $[\text{MVK}]_0$  under sonicated conditions with an increase of only 13:1 to 16:1 between  $[\text{MVK}]_0$  values of  $1.0 \text{ mol L}^{-1}$  and  $0.05 \text{ mol L}^{-1}$ , respectively. Figure 4-2 also clearly shows that the conversions achieved after 1 hour are improved under sonicated conditions, especially when

---

$[\text{MVK}]_0 = 1.0 \text{ mol L}^{-1}$ . In effect, ultrasonic enhancement of mass transport rates allows water-like selectivities and conversions to be obtained even when  $[\text{MVK}]_0 = 1.0 \text{ mol L}^{-1}$ .

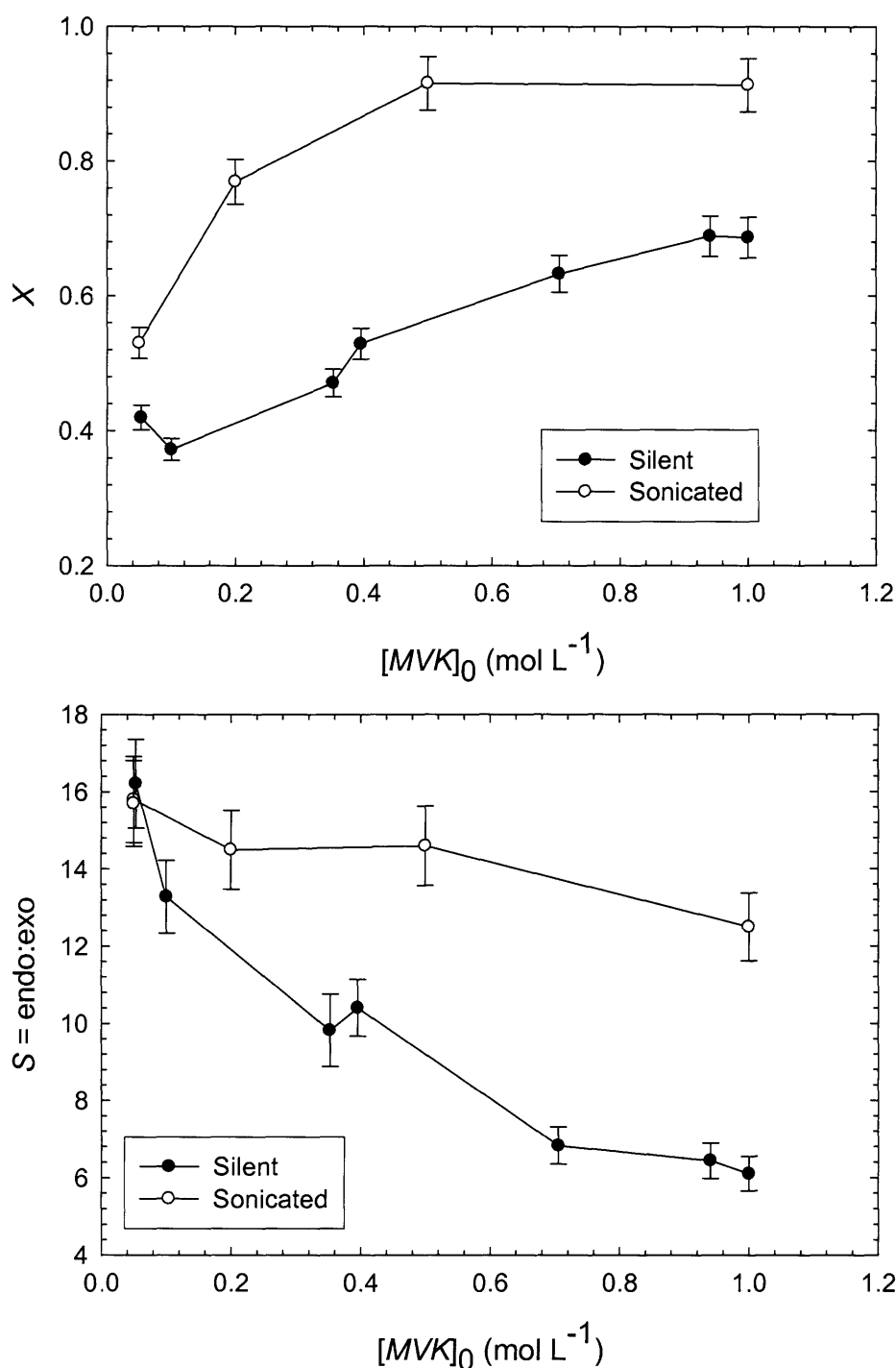

**Figure 4-2.** Experimental measurements of (a) the conversion,  $X$ , and (b) the selectivity,  $S$ , of the Diels-Alder cycloaddition of methyl vinyl ketone with cyclopentadiene in carbon dioxide/water systems plotted versus the initial concentration of dienophile. For the sonicated condition, the horn-to-interface distance is 2 cm. Conditions: 30 °C, 80 bar, 85% water by volume, 1 hr reaction time. Ultrasound: 20 kHz ultrasound, 25% duty (on a 1 s cycle), 0.55 W cm<sup>-3</sup>.

Following the analysis of Timko (2004), the observed selectivity behavior can be interpreted in terms of the relative rates of the processes described in Table 4-1. Table 4-1 lists estimated mass transport coefficients, rate constants, and Hatta numbers, defined as  $(k_{\text{rxn}}D_A)^{1/2} / k_W$ , in both phases for the extremes in  $[\text{MVK}]_0$ . The mass transport coefficients listed in Table 4-1 are based on the transport measurements of benzaldehyde described by Timko and therefore do not take into account transport to water droplets as they recirculate through the carbon dioxide phase. Thus the mass transport coefficients in Table 4-1 underestimate the total mass transport rates between the two phases. The Hatta numbers indicate that: 1) mass transport in the water film is slightly enhanced by reaction for  $[\text{MVK}]_0 = 1.0 \text{ mol L}^{-1}$  as the water-based Hatta number equals 2 in this case; 2) the carbon dioxide phase is well mixed, as the Hatta number is always much less than unity in this phase. Water-based Dämkohler numbers are less than unity ( $< 1 \times 10^{-2}$ ).

**Table 4-1.** Characteristic values of rate related processes for dynamics of the reaction between methyl vinyl ketone and cyclopentadiene in carbon dioxide/water systems (Timko, 2004).

Rate process	$[\text{MVK}]_0 = 1.0 \text{ mol L}^{-1}$		$[\text{MVK}]_0 = 0.05 \text{ mol L}^{-1}$	
	H <sub>2</sub> O	CO <sub>2</sub>	H <sub>2</sub> O	CO <sub>2</sub>
pseudo-first order reaction rate <sup>a</sup> (s <sup>-1</sup> )	0.04	$2 \times 10^{-5}$	$3 \times 10^{-3}$	$1 \times 10^{-6}$
mass transport coefficient (cm s <sup>-1</sup> )	$3 \times 10^{-4}$ (H <sub>2</sub> O film)	$3 \times 10^{-3}$ (CO <sub>2</sub> film)	$3 \times 10^{-4}$ (H <sub>2</sub> O film)	$3 \times 10^{-3}$ (CO <sub>2</sub> film)
Hatta number <sup>b</sup>	2	0.015	0.5	$4 \times 10^{-3}$
reaction enhanced transport coefficient (cm s <sup>-1</sup> )	$7 \times 10^{-4}$	$3 \times 10^{-3}$	$3 \times 10^{-4}$	$3 \times 10^{-3}$
overall mass transport coefficient (cm s <sup>-1</sup> ), $k_{\text{mt}} \approx k_W / K_{\text{CW}}$ with $K_{\text{CW}}$ (cyclopentadiene) $\approx 100$	$6 \times 10^{-6}$		$3 \times 10^{-6}$	
mass transport coefficient x specific surface area <sup>c</sup> (s <sup>-1</sup> )	$1 \times 10^{-6}$		$6 \times 10^{-7}$	

<sup>a</sup> for the overall rate of disappearance of cyclopentadiene i.e.,  $k_W^N + k_W^X$  or  $k_C^N + k_C^X$

<sup>b</sup> Hatta number,  $\gamma_W = (k_{\text{rxn}} D_{\text{AW}})^{1/2} / k_W$  or  $\gamma_C = k_{\text{rxn}} D_{\text{AC}})^{1/2} / k_C$

<sup>c</sup> assuming that the specific interfacial area =  $20 \text{ cm}^2 / 100 \text{ cm}^3 = 0.2 \text{ cm}^{-1}$ .

---

Using the data in Table 4-1, when  $[\text{MVK}]_0 = 1.0 \text{ mol L}^{-1}$  the pseudo-first-order reaction rate constant in the carbon dioxide phase is  $2 \times 10^{-5} \text{ s}^{-1}$  while the overall rate is  $1 \times 10^{-6} \text{ s}^{-1}$ . The 20-fold difference between the two rates implies that the reaction occurs primarily in the carbon dioxide phase before the cyclopentadiene can be transported to the water phase. This marked difference in rate supports the experimental observation that the selectivity at  $[\text{MVK}]_0 = 1.0 \text{ mol L}^{-1}$  is much closer to the selectivity observed in pure carbon dioxide than that observed in pure water. In contrast, when  $[\text{MVK}]_0 = 0.05 \text{ mol L}^{-1}$  the reaction rate constant in carbon dioxide is  $1 \times 10^{-6} \text{ s}^{-1}$  while the effective transport-limited rate constant to the water phase is  $6 \times 10^{-7} \text{ s}^{-1}$ , less than a two-fold difference. This leads to the conclusion that when  $[\text{MVK}]_0 = 0.05 \text{ mol L}^{-1}$  transport of cyclopentadiene to the water phase is sufficiently fast compared to reaction in the bulk carbon dioxide that a substantial fraction of the water phase is utilized, thus supporting the observation that the selectivity approaches the values reported in pure water at lower concentrations of methyl vinyl ketone. Meanwhile, the trends observed under sonicated conditions are consistent with the findings of Timko (2004) for a biphasic system with small water-based Hatta numbers where a much smaller acoustic effect for systems with low Hatta numbers ( $\text{Hatta} < 0.5$ ) when compared to systems with  $\text{Hatta} > 1$  was reported. As Table 4-1 shows, the Hatta number in the water phase is approximately 0.5 when  $[\text{MVK}]_0 = 0.05 \text{ mol L}^{-1}$ , which supports the observation that sonication does not dramatically improve either the selectivity or the conversion at this condition. In contrast, the significant enhancement in selectivity and conversion that is observed under sonicated conditions when  $[\text{MVK}]_0 = 1.0 \text{ mol L}^{-1}$  is expected as the Hatta number in the water phase is equal to 2.

---

## 4.4 Conclusions

A set of experiments were conducted at a water volume fraction of 0.85 while maintaining the optimal horn-to-interface distance of 2 cm and varying the initial concentration of methyl vinyl ketone from 0.05 to 1.0 mol L<sup>-1</sup>. Under sonicated conditions the most dramatic improvements were seen when the initial methyl vinyl ketone concentration was 1 mol L<sup>-1</sup>. At this concentration the endo:exo selectivity was nearly 13:1 and the conversion after one hour was greater than 90%. These results compare favorably to that obtained silently (6:1 selectivity, 70% conversion) or expected in pure carbon dioxide (4.5:1 selectivity, 30% conversion). As the concentration of methyl vinyl ketone was decreased from 1.0 to 0.05 mol L<sup>-1</sup>, the selectivities and conversions obtained under sonicated conditions approached those obtained without ultrasonic emulsification (16:1 selectivity, 50% conversion). In general, for water/CO<sub>2</sub> systems in which the water-based Hatta number is greater than one, sonication increases mass transport rates in this biphasic system, thus allowing both the selectivity and conversion to approach that of a water-phase reaction without directly encountering solubility limitations of the reactants in water.

## 4.5 References

- Blokzilj, W. and J.B.F.N. Engberts, "Enforced Hydrophobic Interactions and Hydrogen-Bonding in the Acceleration of Diels-Alder Reactions in Water." in *Structure and Reactivity in Water*, ACS Symposium Series, 568, American Chemical Society, Washington D.C., 303, 1994.
- Breslow, R., U. Maitra and D. Rideout, "Selective Diels-Alder Reactions in Aqueous Solutions and Suspensions." *Tetrahedron Lett.* **1983**, 24, 1901.

- 
- Chandrasekhar, J., S. Shariffskul and W.L. Jorgensen, "QM/MM Simulations for Diels-Alder Reactions in Water: Contribution of Enhanced Hydrogen Bonding at the Transition State to the Solvent Effect." *J. Phys. Chem. B* **2002**, *106*, 8078.
- Dähnke, S. and F.J. Keil, "Modeling of Linear Pressure Fields in Sonochemical Reactors Considering an Inhomogeneous Density Distribution of Cavitation Bubbles." *Chem. Eng. Sci.* **1999**, *54*, 2865.
- Diego-Castro, M.J. and H.C. Hailes, "Studies on the Use of Surfactants in Aqueous Diels-Alder Reactions." *Tetrahedron Lett.*, **1998**, *39*, 2211.
- Grieco, P. A., K. Yoshida, and Z. He, "Sodium 6-methoxy-(E,E)-3,5-hexadienoate: A Useful Diene in the Aqueous Diels-Alder Reaction." *Tetrahedron Lett.* **1984**, *25*, 5715.
- Grieco, P.A., P. Garner and Z. He, "Micellar Catalysis in the Aqueous Intermolecular Diels-Alder Reaction: Rate Acceleration and Enhanced Selectivity." *Tetrahedron Lett.* **1983**, *24*, 1897.
- Laborde, J.L., A. Hita, J.P. Caltagirone and A. Gerard, "Fluid Dynamics Phenomena Induced by Power Ultrasounds." *Ultrason.* **2000**, *38*, 297.
- Lubineau, A. and J. Auge, "Water as a Solvent in Organic Synthesis." *Topics in Current Chemistry*, **1999**, *206*, 1.
- Lubineau, A., H. Bienaymé, Y. Queneau and M.C. Scherrmann, "Aqueous Cycloadditions Using Glyco-Organic Substrates – Thermodynamics of the Reaction." *New J. Chem.* **1994**, *18*, 279.
- McMurray, H.N. and B.P. Wilson, "Mechanistic and Spatial Study of Ultrasonically Induced Luminol Chemiluminescence." *J. Phys. Chem. A.* **1999**, *103*, 3955.
- Rideout, D.C. and R. Breslow, "Hydrophobic Acceleration of Diels-Alder Reactions." *J. Am. Chem. Soc.*, **1980**, *102*, 7816.
- Timko, M.T., "Acoustic Emulsions of Liquid, Near-Critical Carbon Dioxide and Water: Application to Synthetic Chemistry Through Reaction Engineering." Ph.D. Thesis, Department of Chemical Engineering, Massachusetts Institute of Technology, Cambridge, MA, **2004**.

## CHAPTER 5

# SYNTHESIS OF NITROGEN-BEARING COMPOUNDS IN DENSE CARBON DIOXIDE AND/OR WATER SYSTEMS

The work in this chapter was conducted as part of the CMI project which is a collaborative project between the following research groups: Professor Jeff Tester (MIT), Professor Rick Danheiser (MIT), and Professor Andy Holmes (Cambridge University, UK). At MIT our lab worked closely with Josh Dunetz of Professor Danheiser's lab. The overall objective of the CMI project is to investigate the application of water and carbon dioxide as "environmentally friendly" media for synthetic, organic reactions involving different types of amines.

### 5.1 Background and Objectives

**Background.** The synthesis of organic compounds in the absence of regulated or potentially toxic solvents is an important industrial goal, and is the motivation for development of alternative reaction media. Supercritical carbon dioxide has recently attracted considerable attention (Qian *et al.*, 2004; Leitner 2002; Glebov *et al.*, 2001; Thompson *et al.*, 1999) as it is non-toxic, inexpensive and universally available. Because supercritical fluids offer the ability to vary density and solvent power through small changes in pressure and temperature, separations of reactants, products, and catalysts are facilitated. The many favorable and tuneable properties of near-critical and supercritical carbon dioxide (scCO<sub>2</sub>) make it attractive for use on an industrial scale.



---

Besides  $\text{scCO}_2$ , water has attracted attention as a potential green solvent due to the work of Breslow and co-workers (1983; Rideout and Breslow, 1980) and Grieco *et al.* (1984; 1983) that demonstrated water's ability to accelerate the rate of certain Diels-Alder reactions over a 1000-fold when compared to conventional organic compounds. A recent review by Lubineau and Auge (1999) describes many types of chemical reactions that demonstrate the advantages, both accelerated reaction rates and improved selectivities (regio- and stereo-), of using water as a reaction solvent rather than conventional hydrocarbon solvents. Although the role of water in these reactions is complex and not completely understood, it is agreed that the hydrophobic effect and enhanced hydrogen bonding of water to highly polarized transition states (Otto and Engberts, 2000) dominate the observed accelerative effects of water on chemical kinetics. The relative contribution of these effects is the subject of current inquiry (Chandrasekhar *et al.*, 2002).

Unfortunately the practical application of both water and  $\text{scCO}_2$  as reaction media has been limited by the poor solvent power they exhibit for many reactants and reagents of interest. Although  $\text{scCO}_2$  will dissolve many non-polar compounds of low molecular mass, many catalysts, substrates, and reagents have limited solubility in this medium. Likewise, most organic reagents display limited solubility in water. The combination of water with  $\text{scCO}_2$  to form a biphasic system is one possible solution to overcome some of the solubility limitations of both solvents because their solvation powers are complementary. In addition, this particular biphasic system allows the accelerative effect of water on chemical kinetics (the hydrophobic effect) to be accessed more readily by using carbon dioxide to dissolve the main reagents which tend to be water insoluble. A

---

limitation of using a biphasic system is the inherent, interphase mass transport resistance that may influence the kinetics of the reaction of interest. One strategy to overcome these potential limitations is the generation of water/CO<sub>2</sub> emulsions which reduce mass transport limitations through the creation of more interfacial surface area. Emulsions can be created using either surfactants (Jacobson et al., 1999; McCarthy et al., 2002) or power ultrasound (Timko, 2004).

To this point, the research in this thesis has focused on Diels-Alder reactions that proceed in a controlled fashion to the desired products and have only involved the formation and/or breaking of carbon-carbon bonds. Nitrogen-bearing chemistry, however, is also of interest as nitrogen heterocycles represent a class of compounds that is extensively used in the pharmaceutical, agrochemical, and electronics industries. Pharmaceutically important compounds include among others: methopholine, yohimbine, vincamine, salsolinol, and debrisoquine. Some synthetic transformations important for the formation of these nitrogen heterocycles are:

- palladium-catalysed amination reactions
- dipolar cycloadditions including nitrile oxide and azomethine ylide cycloadditions
- hetero Diels-Alder reactions of iminium ions
- Mannich and Pictet-Spengler reactions
- enantioselective organocatalytic carbon-carbon bond forming reactions
- palladium-catalysed coupling reactions on solid phase supports.

Although the chemistry of nitrogen-bearing compounds in conventional solvents is well documented (Yokoyama *et al.*, 1999; Gothelf and Jorgensen, 1998; Cox and

Cook, 1995; Larson and Grieco, 1985; Kumar *et al.*, 1982), this chemistry is more difficult in the presence of carbon dioxide as amines can react reversibly with CO<sub>2</sub> to form carbamic acid or alkylammonium carbamic acid salts (Belli Dell'Amico *et al.*, 2003). Both of these compounds are unstable and can lead to the production of undesired by-products. These reactions are shown below where reaction 5-1a is a generic scheme for carbamic acid formation and reaction 5-1b is the generic scheme for alkylammonium carbamic acid salt formation.

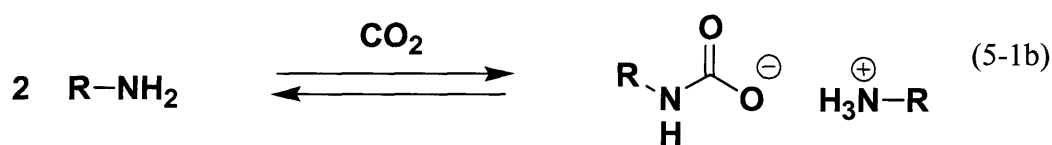

Carbamic acid formation from various primary and secondary amines has been documented using both visual and NMR techniques (Kainz *et al.*, 1999; Fischer *et al.*, 2003). Leitner and co-workers conducted visual experiments involving the secondary amines *n*-ethyl-*n*-benzylaniline and *n*-methyl-*n*-benzylaniline in the presence of CO<sub>2</sub>. In their studies the Leitner group found that *n*-ethyl-*n*-benzylaniline formed a white solid that was attributed to carbamic acid formation. In contrast the Leitner group observed that *n*-methyl-*n*-benzylaniline, which has a bulkier substituent group attached to the nitrogen atom, did not form carbamic acid as no white solid was observed. Albert and co-workers conducted experiments that analyzed the amine/carbamic acid equilibrium in scCO<sub>2</sub> via NMR at 50 °C and 80-200 bar. These experiments focused on various benzylamine

derivatives. As with the Leitner group, Albert and co-workers found that carbamic acid formation from secondary amines could be prevented by using bulkier substituent groups to sterically hinder carbon dioxide's access to the reactive nitrogen atom. More specifically, attachment of an isopropyl or butyl group to the nitrogen atom prevented carbamic acid formation whereas a methyl group did not. A summary of both the Leitner and Albert groups' results are shown in the Figure 5-1:

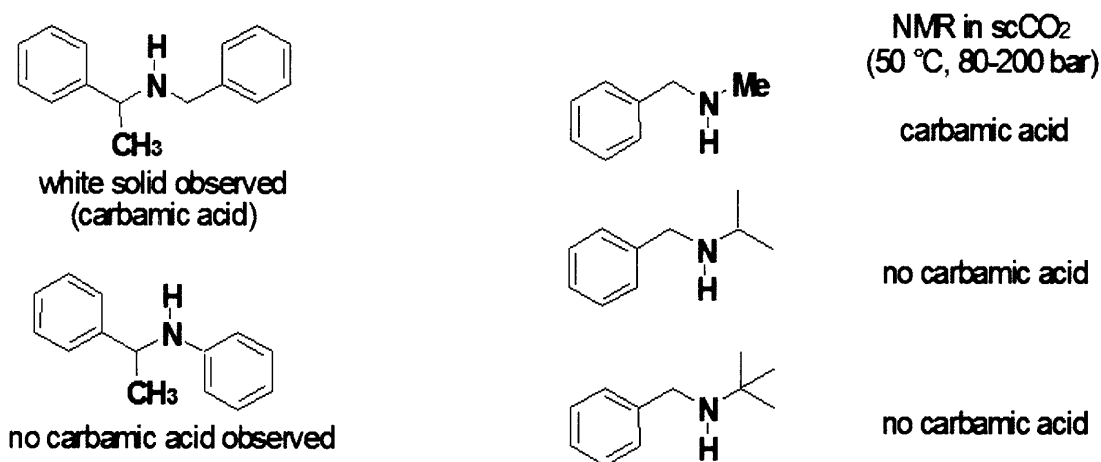

**Figure 5-1.** Results of work by the research groups of Leitner (left column) and Albert (right column) that demonstrate the effect of steric inhibition on carbamic acid formation from different secondary amines.

Supercritical carbon dioxide has also been used in applications where it is both a reagent and a solvent (Salvatore *et al.*, 2002; Selva *et al.*, 2002; Yoshida *et al.*, 2000; McGhee *et al.*, 1995). In these studies, scCO<sub>2</sub> was used as a replacement for phosgene to generate carbamate products from primary and secondary amines at relatively mild conditions. Some of the general schemes that have been proposed are shown in reactions 5-2 (Yoshida *et al.*, 2000) and 5-3 (Selva *et al.*, 2002):

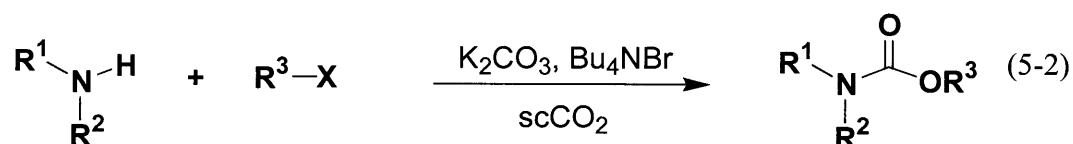

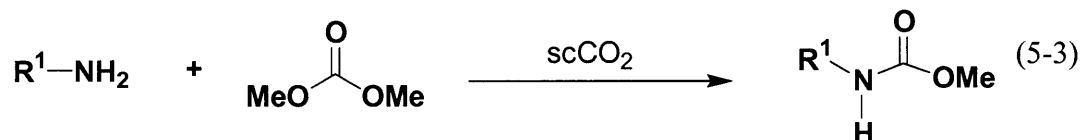

These carbamate reactions are of interest because they represent a “green chemistry” methodology to generate a protecting group *in situ* for the nitrogen atom that can be used in synthesis reactions of nitrogen heterocycles. The work of Venkov and Lukanov (1992), shown in reaction 5-4, demonstrates the use of carbamates as a reagent in Pictet-Spengler reactions involving n-acyliminium ions:

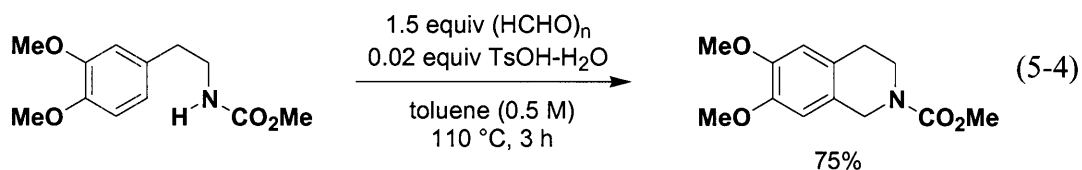

Here the  $-CO_2Me$  substituent is used as a protecting group to prevent carbamic acid generation and to produce high yields of the desired product.

**Objectives.** The objective of this phase of our research was to develop amine chemistry in the presence of  $scCO_2$  by identifying amines and amine derivatives suitable for application in a wide range of important synthetic transformations in carbon dioxide media. The synthesis of nitrogen heterocycles using both hetero Diels-Alder cycloadditions and Pictet-Spengler cyclizations was investigated. Also studied was carbamate formation using  $scCO_2$  as both a reagent and solvent.

## 5.2 Experimental Materials and Apparatus

**Materials.** With the exception of the carbamate compound, all of the reagents, catalysts, and solvents used in these experiments were purchased and used as received from Sigma

Aldrich. The carbamate was synthesized by Josh Dunetz by reacting 3,4-dimethoxyphenethylamine with methyl chloroformate and triethylamine in dichloromethane. Grade 5.5 carbon dioxide (>99.99%) was obtained from BOC and used as received. Deionized water as received from MIT's water supply was further deionized to a minimum resistivity of 18.1 M $\Omega$  cm using a Barnstead Nanopure filtration system.

**Apparatus.** All experiments were performed in the view-cell high-pressure reactor designed and described in detail by Weinstein (1998; Renslo *et al.*, 1997); thus only the basic features of the system are presented here. The reactor, Figure 5-2, was fabricated from a 6.4 cm x 6.4 cm x 12.7 cm block of 316-stainless steel. A cylindrical chamber, with a length of 8.0 cm and a diameter of 1.9 cm was bored into this block. The total working volume of the reactor is roughly  $22.6 \pm 0.6$  cm<sup>3</sup> and the maximum operating pressure is estimated to be approximately 500 bar at 25 °C. Six ports were machined into

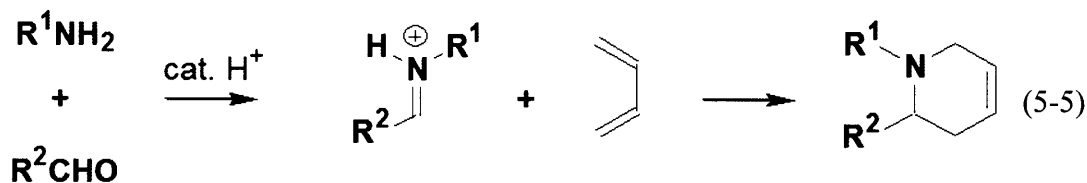

**Figure 5-2.** Digital photograph of the high-pressure view-cell reactor designed by Weinstein (1998) and used for amine chemistry studies in this work.

the pressure vessel and were used for the inlet and outlet valves (Whitey ss-3NBM4), a sampling valve (Valco Instrument Company, Inc. uw-type), pressure measurement, and a thermocouple, respectively. The primary opening to the cylindrical chamber was sealed using an  $\alpha$ -Al<sub>2</sub>O<sub>3</sub> sapphire window and a stainless steel hex nut, similar to that used for the acoustic reactor described in Chapter 4. The pressure seal was made using a combination of Teflon and buna-N rubber (90 durometer on the Shore A scale) gaskets. The reactor contents can be mixed using a Teflon-coated stir bar coupled to a standard magnetic stir plate. Pressure measurements were made using a Bourdon tube pressure gauge (McDaniels Controls Inc.) with a readability of  $\pm 2$  bar. As before, temperature was measured to within  $\pm 1$  °C using a T-type thermocouple (Omega Engineering). The temperature was maintained at its set point using a PID controller (Omega Engineering 9001CN) and thermal heat tape (Barnstead).

### 5.3 Hetero Diels-Alder Cycloaddition

For the hetero Diels-Alder experiments, 2,3-dimethyl-1,3-butadiene was reacted with benzylamine and formaldehyde in several different solvent systems at a temperature of 35 °C. A general scheme for this reaction (Larson and Grieco, 1985) is



Reaction 5-5 shows that the amine, R<sup>1</sup>NH<sub>2</sub>, first reacts with the aldehyde, R<sup>2</sup>CHO, to form an iminium ion, R<sup>2</sup>N<sup>+</sup>HR<sup>1</sup>, which then reacts with the diene, C<sub>4</sub>H<sub>6</sub>, to give the desired nitrogen heterocycle product.

---

**Procedure.** The temperature for these studies was chosen in order to replicate the work of Larsen and Grieco (1985) in which they conduct this experiment in water at 35 °C for 48 h. All of the experiments conducted at atmospheric pressure were performed by Josh Dunetz in the Danheiser laboratory. These experiments include reactions run in water, water/tetrahydrofuran (THF), and water/hexane systems. The pressurized experiments involving carbon dioxide were performed at an arbitrarily chosen pressure of approximately 138 bar in the view-cell pressure vessel depicted in Figure 5-2.

A typical experiment in our lab involved loading the reactor with all the reagents prior to sealing, heating, and pressurizing the system. Generally, specified volumes of benzylamine, 2,3-dimethyl-1,3-butadiene, and aqueous formaldehyde, which are all liquids, were pipetted into the reactor. For runs that required more water than that present in the aqueous formaldehyde, an excess of deionized water was added to the reaction vessel. The reactor was then sealed using a standard torque wrench to a torque of 100 ft-lbs, and heat tape was wrapped securely around the reactor. After connecting the reactor to the carbon dioxide system, a low flow of carbon dioxide was used to purge the system of residual air. Next, the reactor was initially pressurized to 70 bar where it was held for a sufficient time in order to achieve thermal equilibrium. For example, about 10 minutes were required for the reactor to reach the reaction temperature of 35 °C. Once thermal equilibrium was achieved, more carbon dioxide was added to the system until the final pressure of 138 bar was reached. Stirring was provided by using a Teflon-coated stir bar.

After the 48 h reaction time was completed, the carbon dioxide phase in the reactor was vented into cold tetrahydrofuran (THF) following similar procedures to those



documented in Chapter 4. A high-pressure metering valve (Autoclave Engineers 10VRMM2812) heated with thermal tape (Barnstead) operated at 40 V (as set by a standard variable transformer) was used to maintain an even flow of depressurizing carbon dioxide and prevent formation of ice in the vent line. A glass vessel equipped with a frit (10  $\mu\text{m}$  pore diameter) was used to improve recovery of any volatile components. After the reactor was completely depressurized, it was opened and washed several times with THF. These THF washes and the THF that the vent gas was bubbled through were collected and given to Josh Dunetz for quantitative analysis.

**Results.** The Diels-Alder cycloaddition of benzylamine with 2,3-dimethyl-1,3-butadiene was conducted in water, water/THF, water/hexane, and water/scCO<sub>2</sub> media at 35 °C for 48 h unless noted otherwise. The experiments involving CO<sub>2</sub> were conducted in this lab while the remaining experiments were completed by Josh Dunetz. The results of these runs are shown in Table 5-1.

**Table 5-1.** Results of the hetero Diels-Alder cycloaddition in various solvents. All of these reactions were run for 48 h. The numbers in parentheses by each solvent refer to the ratio of volumes used for each solvent in that reaction. Reaction conditions: 35 °C and 138 bar.

<b>Diene<sup>a</sup></b> <b>Concentration</b>	<b>Amine<sup>b</sup></b> <b>Concentration</b>	<b>Solvent</b>	<b>Yield</b>
2.2	2.8	H <sub>2</sub> O	50%
2.2	2.8	H <sub>2</sub> O/THF (1:1)	51%
2.2	2.8	H <sub>2</sub> O/scCO <sub>2</sub> (1:1)	0%

<sup>a</sup>Diene refers to 2,3-dimethyl-1,3-butadiene. The concentration of formaldehyde for all experiments is equal to that of the diene. <sup>b</sup>Amine refers to benzylamine.

As shown in Table 5-1 the 50% yield obtained for the H<sub>2</sub>O case is comparable to the 64% yield of Larsen and Grieco (1985) at the same conditions. For the H<sub>2</sub>O/scCO<sub>2</sub> biphasic experiments, quantitative yields of the desired product were not achieved.

Instead, visual observation of the H<sub>2</sub>O/scCO<sub>2</sub> reaction mixture indicated the presence of an unexpected third phase, which appeared to be a viscous oil-like substance, below the aqueous phase.

Analysis of this oily by-product has proven to be difficult. At this point the only conclusions that have been reached about its identity are that the substance is a polymeric material that is soluble only in n,n-dimethylformamide (DMF), dimethylsulfoxide (DMSO), and 1 M HCl. Control experiments were also conducted to determine the source of the oil formation. Table 5-2 shows the results of these visual experiments in which one or two reagents at a time were added to a water/scCO<sub>2</sub> mixture at 35 °C and 138 bar. From these experiments it was concluded that the minimal reagents necessary to form the oil are the amine and formaldehyde. Since formaldehyde is unreactive and benzylamine forms a white solid that is assumed to be carbamic acid when these two reagents are added alone to the H<sub>2</sub>O/scCO<sub>2</sub> mixture, the unknown, polymeric oil is suspected to be a product of multiple reactions between carbamic acid and formaldehyde.

**Table 5-2.** Results of visual experiments aimed at determining the minimal ingredients necessary to form the unknown oil-like substance. These runs were all conducted in H<sub>2</sub>O/scCO<sub>2</sub> mixtures at 35 °C and 138 bar at the concentrations listed in Table 5-1.

Reagents Used	Visual Observation
Diene alone	Two-phase behavior
Formaldehyde alone	Two-phase behavior
Amine alone	White solid formation
Diene and formaldehyde	Two-phase behavior
Amine and formaldehyde	Viscous oil
Amine, formaldehyde, diene	Viscous oil

Other possible reaction mechanisms for the formation of this oily substance are possible, but at this point no further experiments have been pursued. Some additional control experiments that may be of interest include changing the aldehyde to a less reactive compound such as benzaldehyde and replacing benzylamine with a bulkier amine, possibly a carbamate derivative, that prevents excessive carbamic acid formation.

## 5.4 Pictet-Spengler Cyclization

The hetero Diels-Alder experiments were abandoned after it was determined that amine chemistry in CO<sub>2</sub> might be easier for transformations in which the product is formed via an intramolecular reaction. Reaction 5-6 shows a general scheme that demonstrates the intramolecular cyclization that takes place during a Pictet-Spengler reaction:

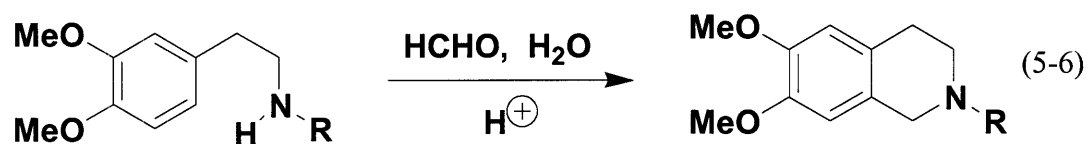

where the substituent R group can be varied in order to protect the nitrogen atom from reacting with CO<sub>2</sub> to form carbamic acid. The hydrogen ion, H<sup>+</sup>, is provided by a catalytic amount of acid which was tosic acid (C<sub>7</sub>H<sub>8</sub>O<sub>3</sub>S(H<sub>2</sub>O)) or TsOH) in these experiments.

**Procedure.** Unlike the hetero Diels-Alder experiments in which only one reaction system was investigated, the Pictet-Spengler studies were more exploratory as different amines, aldehydes, and solvents were studied. Experiments in scCO<sub>2</sub> were performed using dimethoxyphenethylamine and a derivative of this compound, N-methoxycarbonyl-3,4-dimethoxyphenethylamine, which replaces one of the hydrogen protons on the

nitrogen atom with a  $-\text{CO}_2\text{Me}$  substituent group. Besides formaldehyde, the effect of benzaldehyde was also examined for the case when the R substituent was equal to  $\text{CO}_2\text{Me}$ . Finally, the effect of solvent was analyzed by running these reactions in toluene,  $\text{scCO}_2$ ,  $\text{scCO}_2/\text{water}$ , and neat (i.e. no solvent). The pressure of all the experiments was set at approximately 138 bar while the temperature was either 60 or 80 °C depending on the literature conditions that we were trying to replicate. Stirring was again provided by a Teflon-coated stir bar.

The typical setup and procedure for these reactions was similar to that described for the hetero Diels-Alder cycloaddition experiments. As before the reactor was initially loaded with the reagents (the amine, aldehyde, and  $\text{TsOH}$ ), purged of air with  $\text{CO}_2$ , and pressurized to approximately 70 bar. For runs that required excess water, deionized water was added to the system. After allowing sufficient time for the reactor contents to come to thermal equilibrium (approximately 20 to 30 minutes depending on the reaction temperature, 60 or 80 °C), additional  $\text{CO}_2$  was added until the system pressure reached 138 bar. Upon completion of the reaction, the reactor was depressurized and cleaned following the exact procedure used in the hetero Diels-Alder experiments.

**Results.** The first Pictet-Spengler reaction conducted in  $\text{scCO}_2$  was the reaction of 3,4-dimethoxyphenethylamine (0.5 M) with formaldehyde (0.75 M) at 60 °C and 131 bar, reaction 5-7, where  $\text{R} = \text{H}$  for this case.

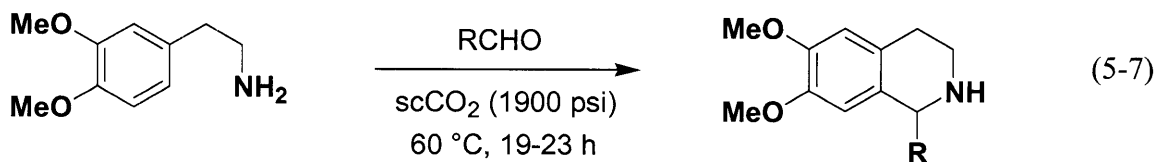

Although not noted in reaction 5-7, a catalytic amount of TsOH (0.025 M) was also added to the reaction mixture.

Unfortunately two separate runs (19 h and 23 h) of this reaction failed to yield any quantifiable amount of the desired cyclization product depicted above. Instead it was found that the primary amine yielded several distinct by-products. Most of these by-products were not characterized, but one interesting product was isolated and characterized. This by-product, the yield of which was approximately 10%, is shown below:



The reaction mechanism responsible for the generation of this by-product is unknown and further research aimed at explaining the mechanism has not been pursued.

Following the failed attempt to form the desired cyclization product starting from a primary amine, schemes for protecting the nitrogen atom were pursued. Research by Venkov and Lukinov (1992) on the Pictet-Spengler reaction, reaction 5-9, demonstrated that attaching an electron withdrawing group (EWG) to the nitrogen atom gave yields between 70% and 90% for the desired cyclization product.

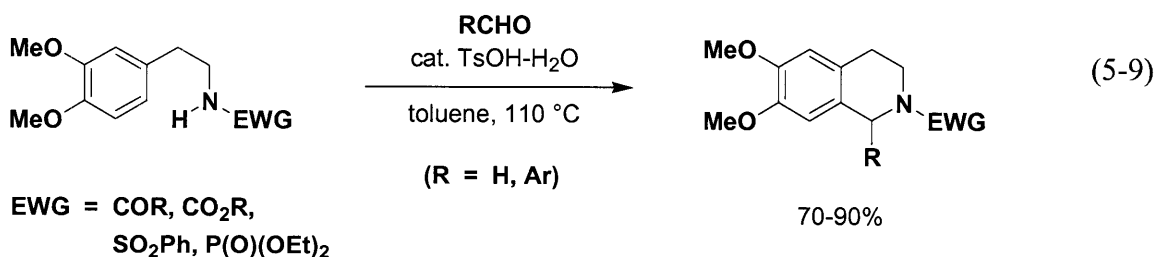

---

Using these results, our next step was to attempt to replicate this chemistry both in toluene and in the scCO<sub>2</sub>/water environment by attaching a -CO<sub>2</sub>Me group to the primary amine used previously. All of the experiments involving this carbamate (N-methoxycarbonyl-3,4-dimethoxyphenethylamine), synthesized by Josh Dunetz as described above, were run at carbamate concentrations of 0.5 M, aldehyde concentrations (either formaldehyde or benzaldehyde) of 0.75 M, and TsOH concentrations of 0.025 M. The pressure was again approximately 138 bar, and the temperature was set at 60 °C for runs using formaldehyde and 80 °C for runs that used benzaldehyde.

Table 5-3 shows the yields for complete carbamate conversion of the desired cyclization product obtained in various solvents when formaldehyde was used as the aldehyde source for the Pictet-Spengler cyclization of carbamate. As the results show, the cyclization of carbamate is much faster and more efficient in toluene than in either scCO<sub>2</sub> or scCO<sub>2</sub>/H<sub>2</sub>O media as it requires a shorter reaction time to reach complete conversion (3 h versus approximately 8 h) and the yields obtained in toluene at shorter reaction times are higher than those obtained in the alternative reaction media. In fact after 3 h only 64% of the carbamate is even converted in the scCO<sub>2</sub>/H<sub>2</sub>O system.

The results of reactions run with benzaldehyde, Table 5-4, as opposed to formaldehyde support the observation that the cyclization of carbamate in toluene is much faster than the rate that can be obtained in a scCO<sub>2</sub>/H<sub>2</sub>O mixture. In this reaction 100% conversion is achieved with toluene after 15 h while only 50% conversion is achieved in scCO<sub>2</sub> after 17 h.

Visual observations of the reactor contents for the experiments described in Tables 5-3 showed that the mixture was a multi-phase system. For the case in which

scCO<sub>2</sub> and H<sub>2</sub>O were combined in a 70:30 volume ratio, three phases were clearly present (from top to bottom): scCO<sub>2</sub>, H<sub>2</sub>O, and a yellow oil. Although the melting point of the carbamate, which is added to the reactor as a yellow solid, is reported to be 178-180 °C,

**Table 5-3.** Yields obtained in various solvents where formaldehyde was used as the aldehyde source for the Pictet-Spengler cyclization of carbamate. The yields reported are for reactions that were allowed enough time for complete conversion of the starting material<sup>c</sup>. Concentrations are: carbamate (0.5 M), formaldehyde (0.75 M), and TsOH (0.025 M). Reaction conditions: 60 °C and 138 bar for pressurized runs.

Solvent	Reaction Time (h)	Yield
Toluene	3	99%
scCO <sub>2</sub> /H <sub>2</sub> O (70:30) <sup>a</sup>	3	64% <sup>c</sup>
scCO <sub>2</sub> /H <sub>2</sub> O (70:30) <sup>a</sup>	17	81%
scCO <sub>2</sub> <sup>b</sup>	17	88%
scCO <sub>2</sub> <sup>b</sup>	8	84%

<sup>a</sup>The numbers in parentheses represent the volume ratio of scCO<sub>2</sub> to H<sub>2</sub>O in the reaction mixture. <sup>b</sup>In actuality there is a little water present for these experiments due to the addition of aqueous formaldehyde to the reaction mixture. <sup>c</sup>This number is actually the conversion of the carbamate achieved after 3 h of reaction time in scCO<sub>2</sub>/H<sub>2</sub>O. It is not an actual yield of the desired product as some undesirable by-products may have formed.

**Table 5-4.** Conversions achieved in toluene and scCO<sub>2</sub> where benzaldehyde was used as the aldehyde source for the Pictet-Spengler cyclization of carbamate. Concentrations are: carbamate (0.5 M), benzaldehyde (0.75 M), and TsOH (0.025 M). Reaction conditions: 80 °C and 138 bar for pressurized runs.

Solvent	Reaction Time (h)	Conversion
Toluene	15	100%
scCO <sub>2</sub> <sup>a</sup>	17	50%

<sup>a</sup>Unlike the formaldehyde case there is in fact no water present as pure benzaldehyde was used in this run.

observations indicated that it began to melt in the reactor vessel near 50 °C. In order to determine the cause of this melting, control experiments were conducted in which the

---

carbamate was added to the reactor by itself, with only water, and with only CO<sub>2</sub>. These different combinations were then heated to 60 °C. For the case where the carbamate was added by itself, nothing appeared to occur as the carbamate remained as a solid. When water was added, the carbamate remained insoluble at low temperatures, but at approximately 50 °C it melted and formed a second, yellow phase below that of water. A similar observation was made for the case of pressurized CO<sub>2</sub> (70 bar) in which the carbamate remained insoluble and solid at low temperatures but proceeded to melt into its own phase near 50 °C.

From these visual observations it was hypothesized that perhaps scCO<sub>2</sub> and water are unnecessary for this particular reaction as they did not seem capable of solvating the carbamate. In fact their presence may be the cause of the slower reaction rate and reduced selectivity when compared to toluene, especially if the system is not mixed properly, simply because they are capable of solvating the tosic acid and aldehyde but not the carbamate, thus preventing sufficient contact between the reagents.

In order to test this hypothesis a couple of reactions were run neat (no solvents) and compared to reactions run in toluene. Table 5-5 contains the results of these experiments which seem to indicate that even toluene inhibits the chemical kinetics of this particular reaction. As shown, the yields obtained in the neat experiments using benzaldehyde (PhCHO) and isobutyraldehyde (*i*-PrCHO) as the aldehyde source are significantly improved over those obtained in toluene at the same conditions and reaction time. Using aqueous formaldehyde (HCHO) the yields obtained in the toluene and neat experiments are similar.



**Table 5-5.** Yields obtained after complete conversion of the carbamate using different aldehydes in both toluene and neat (no solvent) systems. The reaction conditions for each experiment are shown in the table. For the case of HCHO, water was present in small amounts due to the aqueous nature of formaldehyde.

Aldehyde	Conditions	Solvent	Yield
HCHO (aq)	60 °C, 3 h	toluene	98%
		neat	100%
PhCHO	85 °C, 2 h	toluene	21%
		neat	81%
<i>i</i> -PrCHO	80 °C, 23 h	toluene	39%
		neat	77%

**Discussion.** The results presented above suggest that scCO<sub>2</sub> and water do not provide any technological advantages for this particular Pictet-Spengler reaction system as the chemical kinetics of this reaction are much slower and less selective in these alternative reaction media than in toluene. However, one must keep in mind that mixing in our reactor was not ideal as the stir bar was incapable of vigorously mixing all three phases even at its maximum rotational speed. Also we were not able to close mass balances as the carbamate had a tendency to solidify in the outlet lines upon reactor venting. Although we were able to recover approximately 90% of the carbamate in several practice runs, it is possible that some of the desired product could be lost during the venting and cleaning process. Finally, with the exception of using formaldehyde as the aldehyde source, toluene, even with its high solubility for the reagents used in this reaction, does not offer any advantage over running the reaction neat. This result suggests that solvents as a reaction promoter may be unnecessary, which further supports the conclusion that this scCO<sub>2</sub>/water biphasic mixture will not provide any technological

---

advantages since it is incapable of solvating the carbamate reactant that was used in this study.

## 5.5 Carbamate Generation Using CO<sub>2</sub> as a Carbon Source

Although the Pictet-Spengler reaction proved to be disappointing from the standpoint of potentially using water and carbon dioxide as alternative, green solvents, it has led us in a new direction in which carbon dioxide can be used as both a reactant and solvent. The plan for this new path is to basically conduct a “one-pot” synthesis in which carbamate compounds are first generated using CO<sub>2</sub> as a reactant. Generating the carbamate in this manner would allow for the elimination of several organic compounds, such as dichloromethane, that are required for making the carbamate using conventional techniques. The second step would then involve injection of additional reagents required for synthetic transformations of interest, such as the Pictet-Spengler reaction, that are capable of producing nitrogen heterocycles from carbamate starting material.

The formation of carbamates from primary amines and CO<sub>2</sub> has been well documented in the literature (Salvatore *et al.*, 2002; Selva *et al.*, 2002; Yoshida *et al.*, 2000; McGhee *et al.*, 1995). Many different techniques have been utilized by these studies; one of which we are attempting to replicate (Yoshida *et al.*, 2000) and another that we plan to replicate (Selva *et al.*, 2002). The chemical equations for these two methods were shown previously in reactions 5-2 and 5-3. The overall goal of this portion of the project was to find or improve upon a method for generating carbamate products in good yields from primary amines and CO<sub>2</sub> with the added constraint that the reagents used in this method should be compatible with all reagents used in any succeeding synthetic

---

transformations. To date we have only attempted to replicate the Yoshida group's (2000) reactions with unsatisfactory results.

**Procedure.** The procedures that were used to load and empty the reactor are similar to those discussed previously in this chapter. The reactor is first loaded with all the reagents which for this case include: benzylamine (0.10 M), butyl bromide (BuBr) (0.16 M), tetrabutylammonium bromide (5 mol%), and potassium carbonate (0.2 M). Because the butyl bromide can potentially cause undesired N-alkylation of the starting amine, care was taken to prevent their contact by loading in order the benzylamine, tetrabutylammonium bromide, potassium carbonate, and finally the butyl bromide. The reactor was then quickly sealed at a torque of 150 ft-lbs, wrapped with heat tape, and pressurized to approximately 48 bar. After allowing 30 minutes for the reactor to reach thermal equilibrium at 100 °C, additional CO<sub>2</sub> was added to bring the final system pressure to 103 bar. Stirring was provided by a Teflon-coated stir bar.

After 5 h the reaction was quenched by bubbling the CO<sub>2</sub> phase through cold THF using the equipment described earlier. Once depressurized the vessel was opened and washed several times with THF and water. These washes and the cold THF were collected and given to Josh Dunetz for analysis.

**Results.** Our experimental results have been disappointing as we have been unable to replicate the isolated yield of 85% obtained by the Yoshida group (2000). Table 5-6 shows that when the reactor is in the vertical position we were only able to convert 40% of our starting material into the desired carbamate product with another 10% and 35% converted into two undesired products that form as a result of N-alkylation (described

below). One encouraging result is that less than 5% of the starting benzylamine remained unreacted.

**Table 5-6.** Yields obtained from the carbamate generation experiments in two reactor orientations: vertical and horizontal. The listed compounds are benzylamine (1), the desired carbamate (2), and the undesired N-alkylation by-products, (3) and (4).

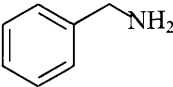
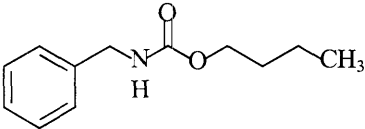
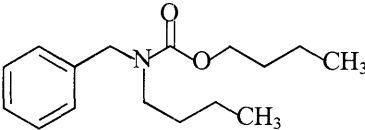
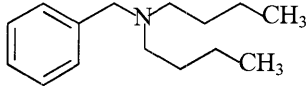
Chemical Compounds		Reactor Orientation	
		Vertical	Horizontal
	(1)	<5%	34%
	(2)	40%	23%
	(3)	10%	6%
	(4)	35%	37%

A possible cause of these less than desirable results is poor mixing conditions that may be present in the reactor. Visual observation of the reactor contents seems to indicate that before addition of CO<sub>2</sub> the mixture of reagents appears to be a thick slurry that is capable of being stirred with a stir bar. However, upon addition of CO<sub>2</sub> the mixture becomes very viscous and stirring ceases after the stir bar becomes trapped in the reaction mixture. Eventually, the stir bar does free itself but the degree of mixing never appears sufficient enough to obtain good contact between the multiple phases that are present. One solution to improve the mixing conditions was to run the reactor in a horizontal

---

position in order to increase the contact area between the CO<sub>2</sub> phase and the other reagents. However, this solution, which we expected to provide better mixing, actually produced yields worse than those observed when the reactor was in the vertical position. These results represent only one experimental run in each reactor configuration so it is likely that the results reported for the horizontal and/or vertical configurations may be incorrect. Further experiments to study the reproducibility of the results for each configuration are planned. As shown in Table 5-6 the final workup in the horizontal position contained only 23% of the desired product, 6% and 37% of the two undesired N-alkylation products, and 34% of unreacted starting amine.

**Discussion.** The large extent to which N-alkylation is occurring in our system is a major concern. From Figure 5-3, which is the mechanism for carbamate generation using the Yoshida group's methodology, N-alkylation (although not depicted) is the direct reaction of butyl bromide (R<sup>3</sup>-X) with the nitrogen atom in benzylamine (R<sup>1</sup>R<sup>2</sup>NH). This reaction can occur twice with the same nitrogen atom to form compound 4 depicted in Table 5-6 or it can occur once as shown in compound 3. The other type of alkylation, O-alkylation, is the reaction of butyl bromide (R<sup>3</sup>-X) with the carbamate anion as depicted in Figure 5-3. O-alkylation leads to the desired product, compound 2 in Table 5-6, and it is also the source of the -OBu group on compound 3.

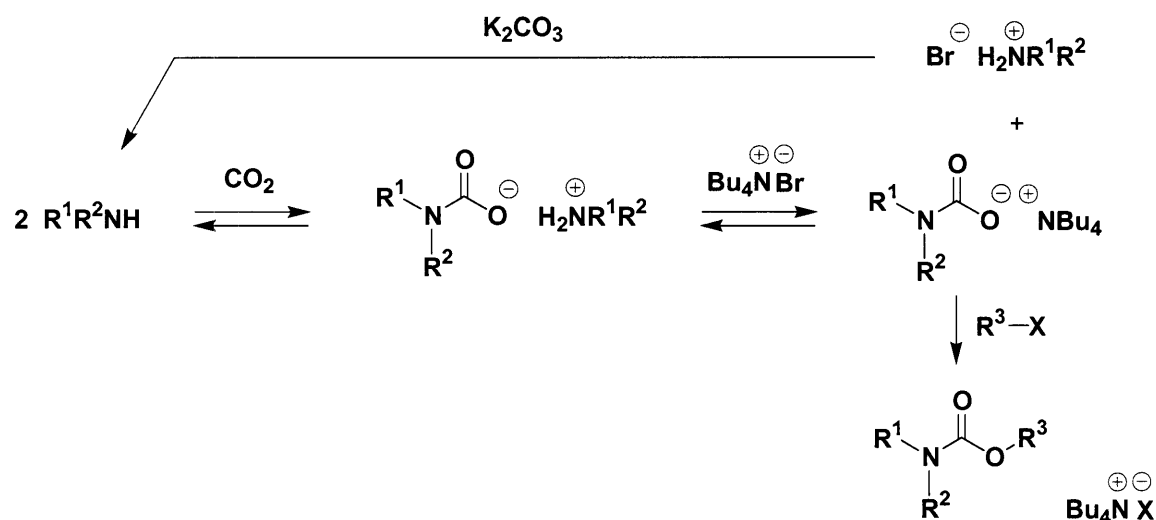

**Figure 5-3.** Mechanism for carbamate generation using scCO<sub>2</sub> as a carbon source for the reaction scheme described by the Yoshida group (2000). Only the primary pathway for generation of the desired carbamate compound is shown. The pathways for undesired by-product formation via N-alkylation reactions are not depicted. For the reaction scheme that we investigated: R<sup>1</sup> = CH<sub>2</sub>C<sub>6</sub>H<sub>5</sub>; R<sup>2</sup> = H; R<sup>3</sup> = C<sub>4</sub>H<sub>9</sub>. Potassium carbonate is also present, and its role is to react with the Bu<sub>4</sub>N<sup>+</sup>X<sup>-</sup> salt to form KX<sup>-</sup>; thus regenerating the phase-transfer catalyst, Bu<sub>4</sub>N<sup>+</sup>.

The Yoshida group with a reactor setup similar to ours (50 mL, cylindrical, 316-stainless steel, and stir bar) does not observe N-alkylation. In general the ratio of N-alkylation versus the desired O-alkylation will depend on a couple of parameters. First, the amount of carbamate anion, BnNHCO<sub>2</sub><sup>-</sup> Z<sup>+</sup> (where Z is the counter ion such as NBu<sub>4</sub> and K<sup>+</sup>), that is present has a large effect since the more the amine is sequestered as the carbamate anion, the less the amount of undesirable N-alkylation that can occur. Because the carbamate anion can be in equilibrium with the amine and CO<sub>2</sub>, one possible way to generate more carbamate anions is to adjust the system pressure in order to drive the equilibrium reaction toward the production of carbamate anions. A second possible cause of N-alkylation is the inability of the carbamate anion and the alkylating agent (BuBr), which respectively reside in the liquid slurry and the scCO<sub>2</sub> phase, to react due to poor

---

mixing between the different phases within the reactor; thus slowing the rate of the desired O-alkylation reaction but allowing more time for N-alkylation to occur.

## 5.6 Conclusions and Recommendations

Our work so far has clearly demonstrated that conducting nitrogen-bearing chemistry in the presence of carbon dioxide is very challenging. All of the reaction systems that we have studied contain complications, including both the feasibility of certain chemical pathways in scCO<sub>2</sub> and physical issues such as the degree of mixing in our reactor apparatus, which have inhibited our progress. Despite the problems that we have encountered, a few conclusions can be drawn:

- When using scCO<sub>2</sub> as a solvent, primary amines are not a good starting material due to their reactivity with carbon dioxide. Both the hetero Diels-Alder and Pictet-Spengler methods were incapable of using primary amines.
- Carbamates as a starting material offer promise for use in synthetic transformations in the presence of CO<sub>2</sub>. Reasonable yields (84% in scCO<sub>2</sub> versus 100% in toluene after 8h) and conversions (64% in scCO<sub>2</sub> versus 100% in toluene after 3 h) were obtained for the Pictet-Spengler reaction when starting with the carbamate, N-methoxycarbonyl-3,4-dimethoxyphenethylamine. However, the advantage of using carbon dioxide, water, or even toluene as solvents for this particular reaction is debatable as the reaction proceeded significantly faster when run neat (i.e. with no solvents).

- 
- Carbamates would be even more attractive as a protecting group for nitrogen if a “one-pot” synthesis can be developed to generate the desired nitrogen heterocycle from a primary amine via a carbamate intermediate. Because the role of carbon dioxide and water in the Pictet-Spengler reaction involving the carbamate is questionable, the generation of carbamates using CO<sub>2</sub> as both a reactant and solvent would give carbon dioxide a quantifiable use as it would replace conventional solvents such as phosgene which are normally used for the synthesis of carbamates. Despite our failed attempts to replicate the chemistry of the Yoshida group, this methodology is still encouraging as our collaborators at Cambridge University, UK have been able to obtain an isolated yield of 76% for the desired product using a reactor setup similar to ours.

As for recommendations, there are a few studies that would be beneficial for the completion of the project’s objectives:

- The Selva group’s (2002) procedure for generating carbamates from CO<sub>2</sub> should be investigated and replicated. This reaction scheme is intriguing as it uses dimethyl carbonate (DMC), which is more “green” than BuBr, as an alkylating agent, and it does not require any added base or catalysts. DMC also may act as a beneficial co-solvent for further desired reactions such as the Pictet-Spengler reaction.
- Attempts to replicate the chemistry of the Yoshida group (2000) should be continued. Our failure to obtain yields reasonably close to those of Yoshida and co-workers are likely due to inefficient mixing and/or poor



---

temperature control in our reactor system. Procurement of a new autoclave reactor with better agitation, temperature control, and a variable feed injection system is underway.

- Once a successful method has been developed for the generation of carbamates from CO<sub>2</sub>, “one-pot” methods for the synthesis of nitrogen heterocycles should be investigated. Pictet-Spengler cyclizations, hetero Diels-Alder cycloadditions, and dipolar cycloadditions among others are synthetic transformations that can be studied.

## 5.7 References

- Belli Dell’Amico, D., F. Calderazzo, L. Labella, F. Marchetti and G. Pampaloni, “Converting Carbon Dioxide into Carbamate Derivatives.” *Chem. Rev.* **2003**, *103*, 857.
- Breslow, R., U. Maitra and D. Rideout, “Selective Diels-Alder Reactions in Aqueous Solutions and Suspensions.” *Tetrahedron Lett.* **1983**, *24*, 1901.
- Chandrasekhar, J., S. Shariffskul and W.L. Jorgensen, “QM/MM Simulations for Diels-Alder Reactions in Water: Contribution of Enhanced Hydrogen Bonding at the Transition State to the Solvent Effect.” *J. Phys. Chem. B* **2002**, *106*, 8078.
- Cox, E. D. and J.M. Cook, “The Pictet-Spengler Condensation: A New Direction for an Old Reaction.” *Chem. Rev.* **1995**, *95*, 1797.
- Fischer, H., O. Gyllenhaal, J. Vessman and K. Albert, “Reaction Monitoring of Aliphatic Amines in Supercritical Carbon Dioxide by Proton Nuclear Magnetic Resonance Spectroscopy and Implications for Supercritical Fluid Chromatography.” *Anal. Chem.* **2003**, *75*, 622.
- Glebov, E.M., L.G. Krishtopa, V. Stepanov and L.N. Krasnoperov, “Kinetics of a Diels-Alder Reaction of Maleic Anhydride and Isoprene in Supercritical CO<sub>2</sub>.” *J. Phys. Chem. A* **2001**, *105*, 9427.
- Gothelf, K. V. and K.A. Jorgensen, “Asymmetric 1,3-Dipolar Cycloaddition Reactions.” *Chem. Rev.* **1998**, *98*, 863.

- 
- Grieco, P. A., K. Yoshida, and Z. He, "Sodium 6-methoxy-(E,E)-3,5-hexadienoate: A Useful Diene in the Aqueous Diels-Alder Reaction." *Tetrahedron Lett.* **1984**, *25*, 5715.
- Grieco, P.A., P. Garner and Z. He, "Micellar Catalysis in the Aqueous Intermolecular Diels-Alder Reaction: Rate Acceleration and Enhanced Selectivity." *Tetrahedron Lett.* **1983**, *24*, 1897.
- Jacobson, G.B., C.T. Lee, R.P. daRocha and K.P. Johnston, "Organic Synthesis in Water/Carbon Dioxide Emulsions." *J. Org. Chem.* **1999**, *64*, 1207.
- Kainz, S., A. Brinkmann, W. Leitner and A. Pfaltz, "Iridium-Catalyzed Enantioselective Hydrogenation of Imines in Supercritical Carbon Dioxide." *J. Am. Chem. Soc.* **1999**, *121*, 6421.
- Kumar, P., K.N. Dhawan, K. Kishor, K.P. Bhargava and R.K. Satsangi, "1-Phenyl-6,7-disubstituted 2-(3-disubstituted aminopropyl)-1,2,3,4-tetrahydroisoquinolines as Possible Antitubercular Agents." *J. Heterocycl. Chem.* **1982**, *19*, 677.
- Larsen, S.D. and P.A. Grieco, "Aza Diels-Alder Reactions in Aqueous Solution: Cyclocondensation of Dienes with Simple Iminium Salts Generated Under Mannich Conditions." *J. Am. Chem. Soc.* **1985**, *107*, 1768.
- Leitner, W., "Supercritical Carbon Dioxide as a Green Reaction Medium for Catalysis." *Acc. Chem. Res.* **2002**, *35*, 746.
- Lubineau, A. and J. Auge, "Water as a Solvent in Organic Synthesis." *Topics in Current Chemistry*, **1999**, *206*, 1.
- McCarthy, M., H. Stemmer and W. Leitner, "Catalysis in Inverted Supercritical CO<sub>2</sub>/Aqueous Biphase Media." *Green Chem.* **2002**, *4*, 501.
- McGhee, W., D. Riley, K. Christ, Y. Pan and B. Parnas, "Carbon Dioxide as a Phosgene Replacement: Synthesis and Mechanistic Studies of Urethanes from Amines, CO<sub>2</sub>, and Alkyl Chlorides." *J. Org. Chem.* **1995**, *60*, 2820.
- Otto, S. and J.B.F.N. Engberts, "Diels-Alder Reactions in Water." *Pure Appl. Chem.* **2000**, *72*, 1365.
- Qian, J., M.T. Timko, A.J. Allen, C.J. Russell, B. Winnik, B. Buckley, J.I. Steinfeld and J.W. Tester, "Solvophobic Acceleration of Diels-Alder Reactions in Supercritical Carbon Dioxide." *J. Am. Chem. Soc.* **2004**, *126*, 5465.
- Renslo, A. R., R.D. Weinstein, J.W. Tester and R.L. Danheiser, "Concerning the Regiochemical Course of the Diels-Alder Reaction in Supercritical Carbon Dioxide." *J. Org. Chem.* **1997**, *62*, 4530.

- 
- Rideout, D.C. and R. Breslow, "Hydrophobic Acceleration of Diels-Alder Reactions." *J. Am. Chem. Soc.*, **1980**, *102*, 7816.
- Salvatore, R.N., F. Chu, A.S. Nagle, E.A. Kapxhiu, R.M. Cross and K.W. Jung, "Efficient Cs<sub>2</sub>CO<sub>3</sub>-promoted Solution and Solid Phase Synthesis of Carbonates and Carbamates in the Presence of TBAI." *Tetrahedron* **2002**, *58*, 3329.
- Selva, M., P. Tundo and A. Perosa, "The Synthesis of Alkyl Carbamates from Primary Aliphatic Amines and Dialkyl Carbonates in Supercritical Carbon Dioxide." *Tetrahedron Lett.* **2002**, *43*, 1217.
- Soerens, D., J. Sandrin, F. Ungemach, P. Mokry, G.S. Wu, E. Yamanaka, L. Hutchins, M. DiPierro and J.M. Cook, "Study of the Pictet-Spengler Reaction in Aprotic Media: Synthesis of the  $\beta$ -galactosidase Inhibitor, Pyridindolol." *J. Org. Chem.* **1979**, *44*, 535.
- Thompson, R.L., R. Glaser, D. Bush, C.L. Liotta and C.A. Eckert, "Rate Variations of a Hetero-Diels-Alder Reaction in Supercritical Fluid CO<sub>2</sub>." *Ind. Eng. Chem. Res.* **1999**, *38*, 4220.
- Timko, M.T., "Acoustic Emulsions of Liquid, Near-Critical Carbon Dioxide and Water: Application to Synthetic Chemistry Through Reaction Engineering." Ph.D. Thesis, Department of Chemical Engineering, Massachusetts Institute of Technology, Cambridge, MA, **2004**.
- Venkov, A. P. and L.K. Lukanov, "Improved Methods for the Synthesis of N-Acyltetrahydroisoquinolines." *Syn. Comm.* **1992**, *22*, 3235.
- Weinstein, R.W., "Organic Synthesis in Supercritical Carbon Dioxide." Ph.D. Thesis, Department of Chemical Engineering, Massachusetts Institute of Technology, Cambridge, MA, **1998**.
- Yokoyama, A., T. Ohwada and K. Shudo, "Prototype Pictet-Spengler Reactions Catalyzed by Superacids. Involvement of Dicationic Superelectrophiles." *J. Org. Chem.* **1999**, *64*, 611.
- Yoshida, M., N. Hara and S. Okuyama, "Catalytic Production of Urethanes from Amines and Alkyl Halides in Supercritical Carbon Dioxide, *Chem. Comm.* **2000**, 151.

## CHAPTER 6

### CONCLUSIONS AND RECOMMENDATIONS

The overall objective of this work was to investigate reaction systems in which dense carbon dioxide and water were used as “green” solvents in place of conventional, organic compounds. This research successfully demonstrated carbon dioxide’s ability to accelerate certain Diels-Alder reactions via a solvophobic mechanism. It also followed up on the work of Michael Timko in demonstrating the ability of power ultrasound to accelerate a Diels-Alder reaction in a liquid water/dense carbon dioxide biphasic system through the generation of emulsions. Finally, this thesis began initial work in developing reaction systems capable of producing nitrogen heterocycles in the presence of CO<sub>2</sub>.

These three studies clearly demonstrated the technological advantages that can be gained by selectively using water and/or scCO<sub>2</sub> for certain reaction systems such as those investigated in the solvophobic and ultrasonic acceleration studies. However, nitrogen chemistry proved to be much more complicated in the presence of CO<sub>2</sub> because of the reactivity of amines with CO<sub>2</sub> to form an undesired by-product called carbamic acid. Future work aimed at demonstrating the technological advantages of CO<sub>2</sub> and/or water as alternative reaction media basically involve further quantification of both carbon dioxide’s and water’s role in accelerating chemical reactions and continued investigation of amine chemistry in the presence of CO<sub>2</sub>.

Below are specific conclusions and recommendations for each of the three studies that were conducted as part of this thesis:

---

## Solvophobic Acceleration of a Diels-Alder Reaction in Supercritical Carbon Dioxide

The Diels-Alder reaction of *N*-ethylmaleimide with 9-hydroxymethylanthracene was found to proceed at rates in supercritical carbon dioxide that are much faster than in traditional organic solvents. On the basis of the low solubility of 9-hydroxymethylanthracene in scCO<sub>2</sub>, a solvophobic mechanism, consistent with that proposed for acceleration of this reaction in water and fluorocarbon solvents, was hypothesized to be source of the accelerated kinetics in scCO<sub>2</sub>. This hypothesis is supported by the observed negative pressure and density dependencies of the rate constant which are driven by the positive relationship between fluid density and solute solubility. Clustering phenomena (solute/solvent or solute/solute) arising from density fluctuations near the critical point were ruled out as a potential source of the observed kinetic acceleration because the apparent activation volumes are both large and positive (+350 cm<sup>3</sup> mol<sup>-1</sup>) and only a weak function of reduced temperature. Instead, the large activation volumes can be attributed to changes in the solubility of the reagents relative to that of the transition state with increasing density.

Understanding the solvophobic acceleration of Diels-Alder reactions in scCO<sub>2</sub> provides a tool for selection of model reactions to conduct in supercritical fluids. Typically, reagent selection is based on solubility in scCO<sub>2</sub>, but our results show that solvophobic acceleration can provide a second criterion for the choice of reagents. The similarities of scCO<sub>2</sub> with fluorinated solvents (which are more accessible experimentally than scCO<sub>2</sub>) might also be exploited in the future. However, like water, scale-up of reactions involving sparingly soluble species may be prohibitive for utilizing scCO<sub>2</sub> as a solvent for Diels-Alder reactions and other syntheses.

---

Future work should be conducted to further understand this solvophobic acceleration so that the results uncovered by this investigation might be applied to a wider range of organic reactions. Possible focal points include: (1) determination of specific molecular structures which are expected to interact solvophobically in scCO<sub>2</sub>, (2) further quantification of the solvophobic effect, particularly in the presence of hydrogen-bond-donating co-solvents, and (3) development of computational techniques integrating methods from density functional theory and molecular simulation to further molecular-level understanding of reactivity in scCO<sub>2</sub>.

#### **Water as a Catalyst: Conversion and Selectivity of a Diels-Alder Reaction in Carbon Dioxide/Water Systems**

A set of experiments were conducted at a water volume fraction of 0.85 while maintaining the optimal horn-to-interface distance of 2 cm and varying the initial concentration of methyl vinyl ketone from 0.05 to 1.0 mol L<sup>-1</sup>. Under sonicated conditions the most dramatic improvements were seen when the initial methyl vinyl ketone concentration was 1 mol L<sup>-1</sup>. At this concentration the endo:exo selectivity was nearly 13:1 and the conversion after one hour was greater than 90%. These results compare favorably to that obtained silently (6:1 selectivity, 70% conversion) or expected in pure carbon dioxide (4.5:1 selectivity, 30% conversion). As the concentration of methyl vinyl ketone was decreased from 1.0 to 0.05 mol L<sup>-1</sup>, the selectivities and conversions obtained under sonicated conditions approached those obtained without ultrasonic emulsification (16:1 selectivity, 50% conversion). It was concluded that for systems in which the water-based Hatta number is greater than one, sonication increases mass transport rates in this biphasic system, thus allowing both the selectivity and

---

conversion to approach that of water while avoiding some of the solubility limitations of water.

One possibility for future work in the generation of emulsions via power ultrasound is the design of large-scale reactors capable of efficiently producing ultrasonically-induced emulsions. Designs that use vibrating walls or recycle loops that contain a sonicated zone are possible solutions that might allow for technology transfer from the laboratory scale to the industrial scale.

### **Synthesis of Nitrogen-Bearing Compounds in scCO<sub>2</sub> and/or H<sub>2</sub>O Systems**

Conducting nitrogen-bearing chemistry in the presence of carbon dioxide was found to be difficult as the reaction systems that we studied were rife with complications that have inhibited our progress. Despite the problems that we encountered, a few conclusions were drawn:

- Carbamates as a starting material offer promise for use in synthetic transformations in the presence of CO<sub>2</sub>. Reasonable yields and conversions were obtained for the Pictet-Spengler reaction when starting with the carbamate, N-methoxycarbonyl-3,4-dimethoxyphenethylamine. However, the purpose of using carbon dioxide, water, and even toluene as solvents for this particular reaction is debatable as the reaction proceeded significantly faster when run neat (i.e. no solvents).
- Carbamates would be even more attractive as a protecting group for nitrogen if a “one-pot” synthesis can be developed to generate the desired nitrogen heterocycle from a primary amine via a carbamate intermediate. Because the role of carbon dioxide and water in the Pictet-Spengler

reaction involving the carbamate is questionable, the generation of carbamates using CO<sub>2</sub> as both a reactant and solvent would give carbon dioxide a quantifiable use as it would replace conventional solvents such as phosgene which are normally used for the synthesis of carbamates. The results of Yoshida (2000) are encouraging despite our failed attempts to replicate this chemistry.

As for recommendations, there are a few studies that would be beneficial for the completion of the project's objectives:

- The Selva (2002) procedure for generating carbamates from CO<sub>2</sub> should be investigated and replicated. This reaction scheme is intriguing as it uses dimethyl carbonate (DMC), which is more “green” than BuBr, as an alkylating agent, and it does not require any added base or catalysts. DMC also may act as a beneficial co-solvent for further desired reactions such as the Pictet-Spengler reaction.
- Attempts to replicate the chemistry of Yoshida (2000) should be continued. Our failure to obtain yields reasonably close to those of Yoshida is likely due to inefficient mixing in our reactor system. Plans to buy a commercial reactor with better mixing conditions are currently in the early stages.
- Once a successful method has been developed for the generation of carbamates from CO<sub>2</sub>, “one-pot” methods for the synthesis of nitrogen heterocycles should be investigated. Pictet-Spengler cyclizations, hetero



---

Diels-Alder cycloadditions, and dipolar cycloadditions among others are synthetic transformations that can be studied.

---

---

## CHAPTER 7

### APPENDICES

#### 7.1 Experimental Data: Solvophobic Acceleration

Data for the 75 °C runs

The reaction rates for the other temperatures are reported in Table 3-1.

P (bar)	$\rho$ (kg m <sup>-3</sup> )	[A] <sup>a</sup> (10 <sup>6</sup> M)	[B] <sup>b</sup> (10 <sup>4</sup> M)	pseudo-first- order-slope (10 <sup>5</sup> s <sup>-1</sup> )	R <sup>2</sup>	$k_c$ (10 <sup>3</sup> L mol <sup>-1</sup> s <sup>-1</sup> )
128	352 ± 8	5.01	5.00	14.4	0.98	290
138	406 ± 9	9.95	10.2	23.4	0.98	230
152	472 ± 3 0	4.28	4.26	5.14	0.99	120
169	540 ± 8	6.99	6.94	7.75	0.99	110
179	572 ± 7	5.01	5.00	3.79	0.98	76
193	610 ± 22	8.02	8.02	5.64	0.98	70

<sup>a</sup>[A] = concentration of 9-hydroxymethylanthracene

<sup>b</sup>[B] = concentration of N-ethylmaleimide

data file: 75 C solvophobic data.xls

---

---

## 7.2 Experimental Data: Diels-Alder Conversion and Selectivity

Data reported in Chapter 4

*Effect of Initial Concentration of methyl vinyl ketone:*

$\Phi_w = 0.85$ ; 30 °C; 80 bar; 0.6 W cm<sup>-3</sup>; 20 kHz; 25% duty cycle; 1 hr

---

<b>Silent Conditions</b>		
<b>[MVK]<sub>0</sub> (mol L<sup>-1</sup>)</b>	<b><i>X</i></b>	<b><i>S = N/X</i></b>
0.05	0.42	16.2
0.10	0.37	13.3
0.35	0.47	9.8
0.40	0.53	10.4
0.70	0.63	6.8
0.94	0.69	6.4
1.00	0.69	6.1

---

<b>Acoustic Conditions</b>		
<b>[MVK]<sub>0</sub> (mol L<sup>-1</sup>)</b>	<b><i>X</i></b>	<b><i>S = N/X</i></b>
0.05	0.53	15.8
0.05	NA	15.7
0.20	0.77	14.5
0.50	0.92	14.6
1.00	0.91	12.5

---