

Computational Haptics:
The *Sandpaper* System for Synthesizing Texture
for a Force-Feedback Display

Margaret Diane Rezvan Minsky

Bachelor of Science, Mathematics
Massachusetts Institute of Technology, June 1978

Submitted to the Program in Media Arts and Sciences,
School of Architecture and Planning,
in partial fulfillment of the requirements for the degree of

Doctor of Philosophy
at the
Massachusetts Institute of Technology
June 1995

© Massachusetts Institute of Technology, 1995
All Rights Reserved

Author

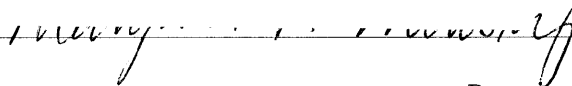

March 19, 1995
Program in Media Arts and Sciences

Certified by

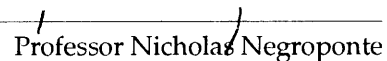

Professor Nicholas Negroponte
Professor of Architecture and Media Arts and Sciences

Certified by

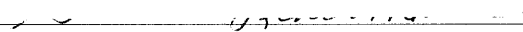

Professor Susan J. Lederman
Professor of Psychology and Computing & Information Science, Queen's University

Accepted by

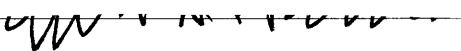

Professor Stephen A. Benton
Chair, Departmental Committee on Graduate Students
Program in Media Arts and Sciences

MASSACHUSETTS INSTITUTE
OF TECHNOLOGY

JUL 06 1995

**Computational Haptics:
The *Sandpaper* System for Synthesizing Texture
for a Force-Feedback Display**

Margaret Diane Rezvan Minsky

Submitted to the Program in Media Arts and Sciences,
School of Architecture and Planning, on March 19, 1995
in partial fulfillment of the requirements for the degree of
Doctor of Philosophy in Media Arts and Sciences

Abstract: Computational haptics is the art and science of creating systems that interact with the sense of touch. To simulate surface textures we constructed a haptic interaction system called *Sandpaper*, which uses a force-feedback joystick and a novel lateral-force gradient algorithm. Using this system, we created haptic simulations of mechanical systems, solid materials, real-world surface textures, non-physical materials, and some haptic representations of medical imagery, and a user interface prototype.

We conducted a program of exploratory research on haptic perception of simulated textures. The first experiment studied whether subjects were convinced that the lateral-force gradient simulations felt like textured surfaces. Confidence was high for certain kinds of simulations of texture and surface features, but low for simulations of other kinds of smooth, jittery, and other non-textural materials. The subjects' descriptions provided rich information about the role of force magnitudes, feature sizes, and several other aspects of the simulations. Two more experiments were aimed at understanding the perceptual aspect of texture called roughness. We concluded that in the case of grating textures — that is, small, periodic ridges — the roughness percept can be almost entirely predicted by the maximum lateral force encountered when feeling the simulation. This could provide controlled roughness feelings in haptic simulation environments.

We propose a framework for haptic models based on using both physically-based and perceptually-based representations of the haptic properties of objects and situations. We also consider representative-based descriptions that refer to familiar types of objects. Perceptually-based representations may be especially useful for interaction technologies, and describing perceptual phenomena in terms of physically-based models should lead to effective and efficient ways to implement haptic simulations. The qualitative results of these studies underscore the multidimensional nature of haptic texture and materials perception.

Improvements and extensions to the present work are discussed as well as a program of research in haptic interaction. An extensive bibliography in haptics and related fields is included.

Thesis Supervisor: Prof. Nicholas Negroponte

Title: Professor of Architecture and Media Arts and Sciences, MIT

Thesis Supervisor: Prof. Susan J. Lederman

Title: Professor of Psychology and Computing & Information Science, Queen's University

Computational Haptics: The *Sandpaper* System for Synthesizing Texture for a Force-Feedback Display

Margaret Diane Rezvan Minsky

Massachusetts Institute of Technology
Program in Media Arts and Sciences

Committee Reader Page

Thesis Supervisor

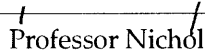
Professor Nicholas Negro Ponte
Professor of Architecture and Media Arts and Sciences, MIT

Thesis Supervisor

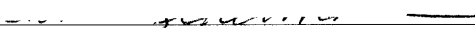
Professor Susan J. Lederman
Professor of Psychology and Computing & Information Science, Queen's University

Reader

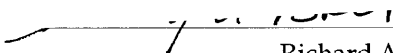
Richard A. Bolt
Senior Research Scientist, MIT Media Lab

Reader



Professor Frederick P. Brooks, Jr.
Kenan Professor of Computer Science
University of North Carolina at Chapel Hill

Table of Contents

Abstract	2
Acknowledgments	8
1 Introduction.....	10
1.1 Introduction	10
1.2 Perceptual-Material Approach to Haptic Interaction	11
1.3 Summary of contributions	12
1.4 Organization of thesis	13
1.5 Multi-Level Language for Description of Haptics Materials	14
1.5.1 Haptic Description Practice	14
1.5.2 Material-Perceptual Description Framework	16
1.6 Call for a World Haptics Library	19
2 Related Work.....	22
2.1 History of Directly Related Haptic Interaction Projects	23
2.1.1 Atari Labs	23
2.1.2 Vivarium	24
2.1.3 UNC-Chapel Hill	25
2.1.4 Less Formal Early Influences on this Work	26
2.2 Haptic Perception	26
2.3 Haptic (and Visual) Perceptual Spaces	29
2.4 Surveys	31
2.4.1 Definitions of Haptics	31
2.4.2 Cutaneous Sensing	31
2.4.3 Tactile Arrays	32
2.4.4 Proprioception and Kinesthesia	32
2.4.5 Texture perception	32
2.4.6 Haptic interaction with computer environments and hand-based input/ output	32
2.4.7 Robotics and Teleoperation	33
2.5 Summary of Haptic Interaction Projects	33
3 Dynamics and Textures in the Sandpaper System.....	38
3.1 Introduction	38
3.2 Sandpaper System: Software is in Control	38
3.2.1 Design Criteria fulfilled by Sandpaper	39
3.2.2 Sandpaper System Modules	41
3.3 Basic Force Feedback	44
3.3.1 : Textbook objects	44
3.3.2 Equations of motion	46
3.3.3 Sandpaper System Characteristics	47
3.4 Lateral-Force Textures: Implementation of Textured Surfaces	48
3.5 Textures for Experiments	54
3.5.1 Textures from Surface Geometry I	54
3.5.2 Textures from Surface Geometry II	55
3.5.3 Other Textures from Surface Geometry	57

3.6	<i>Artifacts and Limitations of Lateral-force Texture</i>	57
3.6.1	Quantization of Force Values	57
3.6.2	Smoothing Filter Issues	59
3.6.3	Analogy to Real Materials	59
4	Confidence Experiment: Convincing Textured Surfaces	61
4.1	<i>Subjects</i>	62
4.2	<i>Apparatus</i>	62
4.2.1	Physical Set-Up:	63
4.2.2	On the haptic neutrality of a ping pong ball	64
4.3	<i>Stimuli</i>	65
4.4	<i>Procedure:</i>	70
4.5	<i>Results and Discussion:</i>	72
4.5.1	High Overall Confidence	72
4.5.2	Factors contributing to Confidence	72
4.5.3	Intersubject Rating Patterns	80
4.5.4	Texture Descriptions	83
4.5.5	Hand movements	86
5	Quantitative Roughness	89
5.1	<i>Scaling of roughness using magnitude estimation</i>	89
5.1.1	Summary of Results	90
5.2	<i>Method</i>	91
5.2.1	Subjects	91
5.2.2	Stimuli	91
5.2.3	Procedure	93
5.3	<i>Results</i>	95
5.3.1	Roughness Estimate and Maximum Force Amplitude	95
5.3.2	Roughness Estimate and Spatial Period	97
5.3.3	Individual Subjects	98
5.3.4	Hand Motion	102
5.3.5	Subjects' Verbal Descriptions of Roughness Criteria and Localization of Textured Surface	102
5.4	<i>Discussion</i>	105
5.4.1	Dominance of Force Amplitude in this Context	105
5.4.2	Human hand sensitivity to force	105
5.4.3	Comparison with tactile roughness factors	106
5.5	<i>Conclusions</i>	107
5.6	<i>Comparative data for Earplugs and No Earplugs</i>	107
5.6.1	Sound Cues	107
6	Qualitative Roughness.....	109
6.1	<i>Qualitative Roughness Experiment: Exploring Perceptual Salience of Force Amplitude and Spatial Period for Roughness Similarity</i>	109
6.2	<i>Method</i>	110
6.2.1	Apparatus	110
6.2.2	Subjects	111

6.2.3 Stimuli	111
6.2.4 Force amplitudes of stimuli	112
6.2.5 Procedure	113
6.3 <i>Results and Discussion</i>	117
6.3.1 Summary	117
6.3.2 Notes on Visual Interpretation of Individual Sorting Data and Cluster Analysis	118
6.3.3 Force Amplitude and Spatial Period as Factors	119
6.3.4 Quantitative coding procedure for analysis of grouping patterns.	128
6.3.5 Verbal description framework	128
6.3.6 Transition near 2.5 mm	128
6.3.7 Characteristic Groupings	129
6.3.8 Limitations of this Experiment	130
6.3.9 Conclusions: Interaction between Spatial and Amplitude factors in the perception of qualitative classes of textures	134
7 Conclusions and Future Work	139
7.1 <i>Conclusions</i>	139
7.2 <i>Future Work</i>	140
7.3 <i>Creating Additional Lateral-Force Simulated Textures</i>	141
7.4 <i>Refined Experiments on the Texture Space of Lateral-Force Textures</i>	141
7.5 <i>Perceptual Dimensions of Texture and Material</i>	142
7.5.1 Clustering Experiment to Characterize Haptic Perception Space	143
7.6 <i>Materials Synthesis</i>	143
7.6.1 Friction, napped materials, crushables, and non-physical materials	143
7.6.2 Sound	144
7.6.3 Solid Textures	145
7.7 <i>Normal-Force Textures and Texture Mapping</i>	145
7.7.1 Haptic texture mapping: combining material and shape properties	145
7.7.2 Combining lateral- and normal-force textures	146
7.8 <i>Representation of Material, Shape, and other Haptic Properties</i>	147
7.8.1 Combining representations of texture, materials, shape, and other haptic properties	147
7.8.2 Graphics interface	148
7.8.3 Application-driven haptic display from a rich representation	148
7.9 <i>New Displays</i>	149
7.9.1 Handles	149
7.9.2 Several fingers together; two hands together	150
7.9.3 Two (or more) people together	150
7.9.4 Display to other parts of the body	150
7.9.5 Hybrid Objects: Combining Real and Simulated Haptics	151
7.10 <i>Sample Applications for Haptic Display</i>	152
References	155
Appendix A: Visual Representation of Version-1 and Version-2 Textures	181
Appendix B: Sandpaper Reference Manual	196
Appendix C: Qualifier Paper	210

List of Figures

- FIGURE 1. Three styles in people's descriptions of how things feel 15
- FIGURE 2. Three layers of description of haptic materials 17
- FIGURE 3. Screen from Sandpaper system 41
- FIGURE 4. Block diagram of joystick/Sandpaper system 45
- FIGURE 5. Stylus on a small hill 50
- FIGURE 6. Procedural triangle wave texture 52
- FIGURE 7. Seed for version-2 textures 56
- FIGURE 8. Seed scaled and repeated for 2.5 mm grating 56
- FIGURE 9. Seed scaled and repeated for 5.0 mm grating 56
- FIGURE 10. Confidence experiment set-up 64
- FIGURE 11. Confidence experiment stimuli chart I 68
- FIGURE 12. Confidence experiment stimuli chart II 69
- FIGURE 13. Mean confidence for gratings vs. maximum force amplitude 75
- FIGURE 14. Mean confidence for Perlins vs. maximum force amplitude 76
- FIGURE 15. Mean confidence for non-texturals vs. maximum force amplitude 77
- FIGURE 16. Histograms of subject confidence ratings 82
- FIGURE 17. Grating texture seed for roughness estimation, black is hill, white is valley 92
- FIGURE 18. Magnitude estimates vs. force amplitude 96
- FIGURE 19. Regression of roughness on force amplitude 97
- FIGURE 20. Multiple regression of roughness estimate on amplitude (amp) and period (per) 98
- FIGURE 21. Subjects' mean roughness vs. absolute amplitude (mean of 4 runs) 99
- FIGURE 22. Experimental setup for sorting task (qualitative roughness) 114
- FIGURE 23. 4-group sort 117
- FIGURE 24. Pictures representing the 2-group sorts for all subjects 121
- FIGURE 25. Cluster analysis of 2-group sort 122
- FIGURE 26. Pictures representing the 3-group sorts for all subjects 123
- FIGURE 27. Cluster analysis of 3-group sort 124
- FIGURE 28. Pictures representing the 4-group sorts for all subjects 125
- FIGURE 29. Cluster analysis of 4-group sort 126
- FIGURE 30. Subject progressions: individual 2-,3-,4-group sorts shown from left to right 136
- FIGURE 31. Verbal group descriptions for 4-group sorts 137
- FIGURE 32. Verbal group descriptions con't. 138

Acknowledgments

I met my husband and collaborator, Oliver Steele, when we worked together starting this project. Oliver built the Sandpaper software system, and no part of this work has gone untouched by him. He has been an integral partner in this project: software, haptic modules, emergency changes, learning physics, writing, discussions. His love and support in every imaginable way, tangible and intangible, has made it all possible. I love you always.

It is my pleasure to thank my thesis advisors, Nicholas Negroponte and Susan Lederman. Nicholas has shown unswerving loyalty, an example of elegance in all things, and guts as an intellectual and a leader. The Media Lab is research heaven on earth, thanks for creating it. Susan agreed to work on this project with enthusiasm, collaborative spirit, lots of guidance, patience, and above all her example of ethical scholarship.

Fred Brooks got haptics going many years ago when others thought it was wacky, and welcomed me to the team at his wonderful laboratory. Richard Bolt provided accessible, interested support, and several times miraculously came up with just the right reference or article.

Cynthia Solomon has been a friend since I was five and a colleague over many years. On top of everything else, Cynthia flew out to Palo Alto to edit this document, so that once again an impossible deadline became possible, and the unreadable became readable.

Max Behensky has been a friend since the loft and a colleague since Atari, started force-feedback work at Atari, built the first joystick electronics (yes, they did survive falling off the car on the Southeast Expressway), provided innumerable tips, and let us play *Hard Drivin'*. Doug Miliken created the Atari and the Vivarium joysticks, and has been a generous friend, a great storyteller, and our one true source of vehicle lore. Megan Smith created the 1D at Vivarium and made sure haptics rolled along at the lab; she is insightful, generous, and tireless, a friend now and I hope we work together again. Massimo Russo built the 3D joystick, and has been a terrific colleague and a wonderful presenter and educator.

David Banks completed our texture trio at UNC, and has remained a friend. Ken Perlin has been a friend over the years; he provided the naturalistic textures, and understands haptics deeply. Doug Lenat got us excited about creating a material no one has ever felt before. Bill Verplank suggested many of the pictures. It has been a pleasure to work together, and he has convinced me there really is visual thinking.

Wendy Plesniak works on haptics at MIT and IRC and to our great delight lived at our home last summer. She graces everything she works on, and has been contagiously positive and enthusiastic. An artist, she helped me with almost all of the illustrations in this document.

David Zeltzer graciously welcomed me into his lab with office space and support for joystick research. Linda Peterson promised me I would graduate when I had deep doubts. For helpful and profound discussions, I thank Woodie Flowers, Neville Hogan, Hong Tan (who also loaned her force meter), and Samuel R. Delany.

In the crunch my practice talk critics at Interval and Media Lab had great suggestions: Marc Davis, Wendy Plesniak, John Underkoffler, Ken Haase, Cynthia, Steve Drucker, Gary Drescher. Paige Parsons helped design the cover pages, Steve Drucker and Steve Strassman saved me from

software.

I thank my sponsors: Media Technology Group, Apple Computer External Research, University of North Carolina-Chapel Hill, and Interval Research Corporation.

The CGA group gave me an intellectual home and camaraderie from 1989 on: Dave Sturman, Steve Drucker, and Paul Dworkin (who made significant haptics contributions as well), Dave Chen, Steve Strassman, Mike McKenna, Steve Pieper, Tinsley Galyean, and Michael Johnson.

The Vivarium at the Media Lab was my first haptics home at the Media Lab. Mike Travers, Steve Strassman, and my wonderful officemates Allison Druin and Megan Smith, have each been a powerful force in the outside world as we predicted. Tim Browne, those were the days!

Mark Holzbach especially welcomed me to the Lab with generosity of time and intellectual outreach. He has remained a friend and colleague over the years, and showed me Tokyo too. John Underkoffler, another long-time pal from the lab, helped me make things in the optics lab. Thanks too to Betsy Connors and Julie and Bill Parker. Mike Hawley has been a co-conspirator: little things like the 22-foot Christmas tree. Mike Halle, thanks for watching over our little doggie.

My teachers at the Media Lab have been extraordinary as mentors and as friends: Seymour Papert, Glorianna Davenport who goes the extra mile and more for her students, Tod Machover, Steve Benton. The late Muriel Cooper treated my work with fervor and excitement; my family, my dog, and me with devotion, I am so sad to say good-bye.

The Narrative Intelligence group provided a place to learn, think, and write, allowing the important issues to float to the top: especially Marc Davis, Amy Bruckman, Mike Travers, and Edith Ackermann.

The international haptics community is full of open, friendly people. I thank the community at UNC Graphics Lab: Fred Brooks, Henry Fuchs, Oliver, David, Ming Ouh-young, John Hughes, Greg Turk, Matt Fitzgibbon, Marc Levoy. I thank Hiroo Iwata at Tsukuba and Michitaka Hirose at Tokyo for helpful discussions, intellectual exchange, and hospitality beyond the call of duty.

Cynthia Solomon and Allison Druin; the Thursday night dinners sustained me.

Thanks to my friends who have kept me sane these years: Gary Drescher, Jeannine Mosely and Allan Wechsler, Daniel Weinreb and Cheryl Moreau, Whitfield Diffie, Monica Strauss, Susan Brennan, Arline Geronimus, Dan Huttenlocher.

I thank both Alan Kay and Nicholas, my cupids, for sending me away for a year.

My family and my husband's family have stood by us, and have each given us the most valuable things they could, their love and their time. My father-in-law Max Steele came to take care of us and gave us time to be a family. My mother-in-law, Diana Steele, travels energetically and it is often to be with us. My brother Henry Minsky made beef stew and played the piano, he and my sister-in-law Milan stayed with us last summer, and my sister Julie Minsky took charge.

Miles Steele, my little one, I love you. My parents, Marvin Minsky and Gloria Rudisch Minsky, have seen me through everything with unconditional love and support, with a home that is still home. I thank them more than I can say.

1 Introduction

1.1 Introduction

In our interactions with the world we use our sense of touch all the time. We sense and manipulate objects, touch each other, detect where we are and where our bodies are moving. In contrast, computer environments are impoverished when it comes to providing haptic feedback. Recent progress in interfaces that create sound and imagery only highlights this deficiency.

Many areas of research are necessary to create convincing haptic interaction systems that make the best use of the abilities of the human haptic system to feel, to do work, and to aid in communication.¹

One area in which haptic interaction systems have been weak is the simulation of essential qualities of *materials*, such as fabrics, wood, metal, fur, and skin. Yet there is evidence that these are the most salient haptic characteristics of objects, and would complement visual display of other attributes, such as shape and size.

It has been said of computer graphics in its early years that all objects had “that computer graphics look”: that is, they were made of shiny plastic in a wide variety of shapes and colors. While this is clearly an exaggeration, there is an element of truth. Only as lighting models, physical models, and now perceptual and artistic models have become more sophisticated is there now a truly diverse repertoire of substances that can be rendered.

1. An early version of my thinking about the challenges of building haptic interface devices is in my doctoral qualifier paper (1989), in Appendix C.

Haptic interaction systems have focussed on creating surfaces of rigid objects with particular emphasis on hard walls (without necessarily trying to perceptually match steel, glass, or wood), and compliant, elastic objects. They have also used force fields and variable compliance to communicate information, such as bond strength in molecular simulations.

In order to create flexible simulations capable of suggesting soft silk velvet, rough cotton denim, or sleek silk satin, we need to work on subtler aspects of haptic display, i.e. surface texture and material properties.

In this thesis, I consider one step toward simulating these complex textured materials. I create a model capable of haptically displaying small surface features (irregular or regular bumps of almost any shape) and some kinds of texture.

1.2 Perceptual-Material Approach to Haptic Interaction

I develop a framework for haptic information which might be used to develop a representation language. This framework has three parts: physically-based, perceptually-based, and representative-based descriptions of haptic properties. For example, a physically-based description of an emery paper is a formal model of the geometry and physics of the grit and paper base. A perceptually-based description would be based on relevant percepts such as roughness, density, or sharpness. Finally, a representative-based description would explicitly notate that we are dealing with sandpaper, specifically emery. In this thesis, we are concerned with developing a perceptually-based description of textured surfaces and small surface features.

Most current approaches use physically-based descriptions and models. Representative-based models are seen as a “last resort.” Perceptual descriptions, that is, descriptions of the haptics of objects as points in haptic perceptual spaces, are not well developed. Yet there is evidence that there are dimensionalized ways of describing the haptic properties of at least some classes of

things, for example, textures. Thus, I set out to characterize the haptic perceptual space of a class of simulated textures.

In this thesis I describe a technique for creating a class of textures and small features on surfaces based on their geometry. This allows an automatic pipeline from a height map of small surface features to a haptic display of the surface. Since forces are required only on the hand in a plane, one can create many textures and surfaces with a two degree-of-freedom force-feedback joystick.

The technique creates convincing simulations of some aspects of texture. I have also made exploratory studies of the roughness percept and found that by controlling force amplitude used to simulate a surface with small wavy features (a grating), it is possible to create a controlled level of roughness. However, differences between this simulation of roughness and the perceived roughness of real-world textures point to the need to explore the multidimensional nature of texture simulations. Further, texture is merely one aspect of the material properties we wish to simulate in order to model a wide variety of real-world materials and perhaps even to extend haptic simulation to create materials no one has ever felt before.

1.3 Summary of contributions

- I created an **artifact**: I created a testbed for texture research by combining existing force-feedback joystick technology with *Sandpaper* (a software system) and specific simulated textures. I designed and directed the implementation of the software system and computed some of the textures. I also designed and built an enclosure for the joystick which made it appear as a flat workspace.
- I performed a series of psychophysical **experiments** in this testbed. I analyzed the results of those experiments to 1) verify that I had created a believable simulation of texture, 2) to characterize perception of roughness of simulated textures, and 3) to propose further experiments to create and understand a comprehensive space of simulated textures and materials. I have commented on the differences between perception of simulated textures and perception of tactile roughness of real materials.

•I performed certain engineering **analyses**. In particular, I analyzed certain algorithms that allow the joystick system to simulate texture and suggest improvements.

1.4 Organization of thesis

Chapter 1 presents a brief introduction to haptics, a discussion of the limitations of current approaches to haptic interaction with computer environments, and a statement of my approach (Material/Perceptual) to creating simulated haptic materials with perceptually salient features. This approach suggests that we need a framework of description for haptic models.

Chapter 2 reviews the background research that influenced my thesis work , and contains a brief review of the literature and practice in related fields.

Chapter 3 discusses the *Sandpaper* system, a software environment I designed to experiment with force-feedback haptic interfaces, in particular, textured surfaces. The lateral-force gradient algorithm for texture simulation is described; it is the algorithm used to create textures for the experimental work in the rest of the thesis. Other haptic simulations created with the Sandpaper system are also described.

Chapters 4, 5 and 6 describe a program of exploratory research on haptic perception of simulated textures using a psychophysical methodology.

Chapter 4 describes an experiment in which subjects rated their confidence that simulations created with the lateral-force gradient algorithm were *textured surfaces*. Confidence was uniformly high for a variety of simulations of texture and surface features; confidence was low for haptic simulations of smooth, jittery, and other non-textural simulations. Subjects' descriptions of the simulated materials provided rich information about the role of force and feature size as well as other aspects of the simulations.

Chapter 5 and Chapter 6 describe experiments aimed at understanding the perceptual aspect of texture called *roughness*. I used haptic simulations of gratings with feature size ranging from 0.7 mm to 10.0 mm. I found that a roughness percept can be scaled by subjects over this entire range, and that this roughness percept is almost entirely predicted by the maximum lateral force encountered when feeling the simulation. This provides a potentially useful way of creating controlled roughness within haptic simulation environments, and is encouraging for the development of *perceptually-based* models of objects. The qualitative and descriptive results of these studies, however, underscore the notion that roughness is only one of several aspects of texture (and materials perception) that must be unpacked in order to resynthesize a wide variety of materials in haptic simulations.

In Chapter 7, section 7.1 summarizes my conclusions from creating and exploring the haptic display of surface texture and small surface features. The rest of Chapter 7 describes improvements and extensions to the present work as well as several more speculative areas of future work on haptic interaction.

The Bibliography contains an extensive set of references in haptics and related fields.

1.5 Multi-Level Language for Description of Haptics Materials

This section presents the Material-Perceptual conceptual framework I have developed for describing haptic materials.

1.5.1 Haptic Description Practice

In most of the experimental work in this dissertation, I explored formally a narrow subset of people's descriptive language about texture, concentrating on *roughness*. A limited class of textured surfaces was synthesized successfully. Certain physical parameters (particularly force magnitude)

were used to alter perception of roughness of grating surfaces. The experimental format itself provided a narrow context for the subjects' experience and descriptions of these surfaces.

The world of haptic sensation evoked by the simulated textured surfaces in this dissertation is rich and stands in contrast to any stark summary of the quantitative results. People encountering the simulations have a wide-ranging language of description and metaphor about the composition and nature of these surfaces. They qualitatively catalog the types of surfaces according to perceived surface features or textures. In their descriptive strategies three styles emerge, shown in Figure 1:

FIGURE 1. Three styles in people's descriptions of how things feel

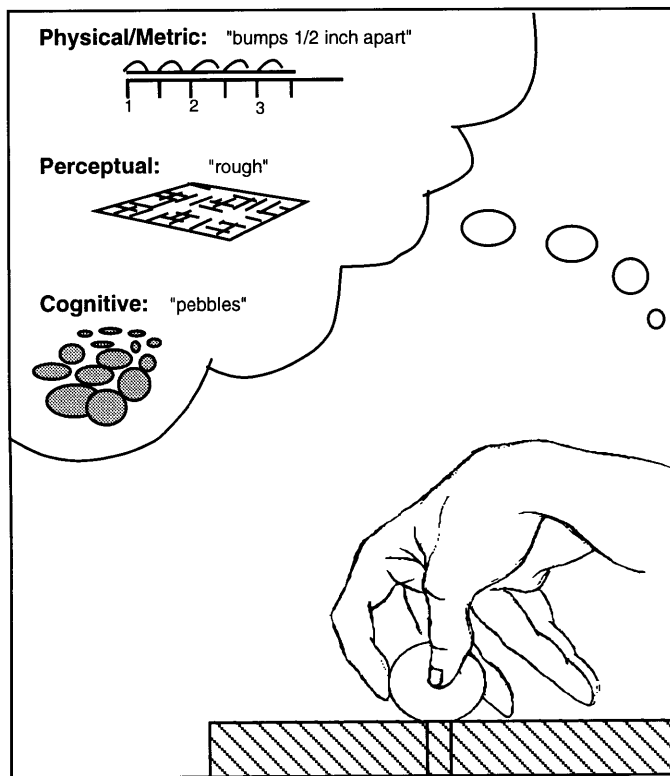

-
- *Physical/Metric* descriptions, e.g., “1/4 inch high bump”, “grooves 1/2 inch apart”
 - *Percept* descriptions, e.g., “rough”, “bumpy”, “slippery”, “sharp”
 - *Cognitive* descriptions
 - semantic, e.g., “pebbles”, “ball bearings”
 - metaphorical, e.g., “like corduroy”
 - functional, e.g., “like driving on a road”
 - affective, e.g., “pleasant”

Subjects’ descriptions are all perceptually mediated; subjects do not have direct knowledge of the physical parameters used to generate simulated textures,. Thus *Physical /Metric* and *Perceptual* descriptions are difficult to distinguish from one another. Subjects do not use physical measuring tools; we (and they) cannot tell which of their perceptual systems lead to physical/metric descriptions that they give. A description of “bumps 1/2 inch apart” may point to an interesting perceptual phenomenon if the simulation’s true spatial feature size is much smaller or larger. However, from the subject’s point of view, *Physical/Metric* and *Perceptual* are different *styles* of description. The *Physical/Metric* descriptions are attempts by subjects to access underlying physical or geometric standards. The *Perceptual* descriptions informally reveal potentially useful perceptual description primitives.

Cognitive descriptions are those which invoke particular objects or situations. They can also be analyzed for useful high-level perceptual primitives.

1.5.2 Material-Perceptual Description Framework

Observations alluded to in the preceding section suggest a descriptive language for haptic materials and textures that has three layers:

- *Physically-based*
- *Perceptually-based*
- *Representative-based*

FIGURE 2. Three layers of description of haptic materials

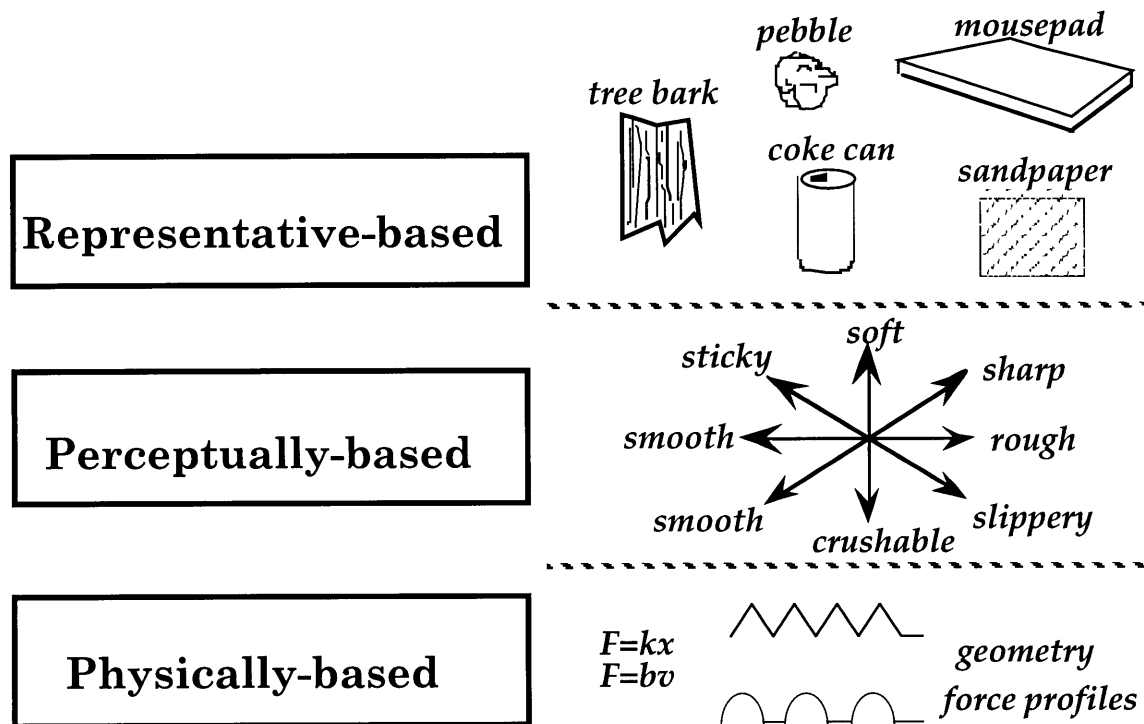

Physically-based descriptions or models are specified using physical properties of the material, surface, or object that we wish to simulate. For example, the exact surface geometry of a textured surface is a physically-based description. When specifying varying amounts of friction, a model that uses geometric descriptions of the microscopic properties of a surface would be a physically-based description. A third example would be a description that uses a parametric friction model from physics theory [Salisbury94].

Perceptually-based descriptions or models are specified using parameters of perceptual primitives. For example, one might specify a degree of roughness (as explored in this thesis), stickiness, or softness. An important long-term goal of this research is to find a set (or sets) of these perceptual

primitives. For example, when specifying varying amounts of friction, the use of a term like *perceived* stickiness rather than *physically-based* friction parameters would be a *perceptually-based* description.

A perceptually-based model might be implemented in terms of its known relationship to parameters of an underlying physically-based model. For example, controlled roughness could be implemented by varying the force-amplitude of the lateral-force-gradient technique described in this dissertation, applied to a single surface geometry. Another type of implementation of a perceptually-based model might depend on a replay of previous empirical measurements of force (or other haptic display parameters) as a function of the percept being modeled, as in [Gillespie94].

Representative-based descriptions use direct description of particular objects or materials to specify a simulation object. In order to make use of representative-based descriptions, there must be a way of translating them into perceptually-based or physically-based descriptions. Some of that reduction is intuitive (for example, a coke can is thin metal; it is hard, yet crushable).

An important reason for preserving the representative-based level of a description as part of a language is to carry along the intent of a simulation in compact form as part of its full description. Also, representative haptic objects may actually provide a more useful specification language for a variety of materials than perceptual primitives. If the representative objects are regarded as “cluster centers,” then a haptic textile simulation to get an interpolated imaginary cloth might be specified by turning dials with labels such as “cotton fleece,” “silk charmeuse,” and “wool gabardine.” These dials would implicitly take care of specifying perceptual parameters such as slipperiness, roughness, softness, nap, coolness, or of physical parameters such as thickness, surface rib width, compliance, friction, and thermal conductivity.

For human-computer interaction purposes, we would like to move from the current state of the art, which centers around physical models of objects and materials, to perceptual and representative-based models.

In order to specify materials in perceptual terms, a set of perceptual description primitives¹ must be determined. In this dissertation, I investigated the notion of roughness as one of the primitive perceptual descriptors in the case of surface textures.

Gillespie and Rosenberg [Gillespie94] have created an interesting and successful model (which they call a perceptual model) in their paper on haptic simulation of the medical procedure, epidural anesthesia. In their model, they combine features of Perceptually-based and Representative-based descriptions. Gillespie and Rosenberg show that theirs is a more successful model for use in haptic simulation than a model based on *de novo* physical models of interaction of medical instruments with human tissues.

1.6 Call for a World Haptics Library

During the course of my thesis research I touched many materials with a heightened introspective stance. When I found the limitations of simulation confounding, I went to my own fabric closet to feel cloth, to my garage to feel sandpaper, outdoors to feel stones and shells. I was creating and returning to my own library of materials for inspiration, to re-familiarize myself with the wide range of sensation and the evocative associations available from simple classes of materials.

1. I use the word primitive here to denote a useful set of perceptual “axes” or “regimes” that can act as generators for a wide variety of materials. The best set of perceptual primitives for computational haptics descriptions may not be the minimal set, and they may not correspond exactly to sensory primitives of the haptic perceptual systems in the human body, although we do hope to understand at some point the basis of the haptics percepts we observe in the human body sensory systems.

I would have found it useful and inspiring to have such a library always “at hand”; and to have a shared set of materials available when talking to others about haptic perception. Thus I call for a “haptics library” standard that could be replicated among the community of haptic researchers.

Since such a library is intended as a permanent collection of samples of materials and textures, it will have a restricted set of materials. For example, each page’s material must be available in a reasonably flat sheet, not require refrigeration or humidity control, not fall apart when touched, and not rub off on the user. Even with these requirements, there are many more surfaces and materials with distinct and interesting haptic properties than could be included. The computational haptics program discussed in this thesis sets as its goals understanding and synthesizing as many of these materials and surfaces as possible. Having a wide variety of real materials available is the best way to be reminded of the range of materials we can sense by touch, and to encourage others to join in building as comprehensive a set of these materials as possible.

Along with this real library of materials, a library of synthetic surfaces and materials needs to be created that can be used in haptic displays. Hopefully, such a library of haptically modeled objects can be even more useful than libraries of object models for visual display have been in computer graphics. The graphics libraries are already highly successful and useful to practitioners in that field, and as yet they are almost exclusively physically-based models. Enhanced usefulness could result from the multi-level material/perceptual representation of haptic models.

An implied challenge is to specify the haptics library in the Material/Perceptual descriptive language: physically-based, perceptually-based, and representative-based. One of the major functions of a library of materials is to assure that the description language does in fact encompass many of the materials available in the library. (What about synthetic haptic materials that do not exist in the real world? One example from this dissertation work is the “negative viscous” material; which is called `slick` in Chapter 4. It is a patch in which the material you feel is generated by the physical

model $F = -bv$, where v is velocity and b is a (negative) damping constant. Your hand is pushed harder in proportion to the speed it moves. As a physical phenomenon, this is unlike any known material. An interesting question is whether it is also unusual or unidentifiable in perceptual space. Many people react to it by considering it slippery, like ice. Further research is needed to find out whether human perception distinguishes this unusual material from a situation closer to reality, for example a frictionless or low-friction surface.)

2 Related Work

Since 1985 the number of research projects on haptics has increased dramatically throughout the world .

Section 2.7 briefly describes the history of projects in the same “evolutionary tree” as the approach adopted in this dissertation. The projects I describe are those that preceded and directly influenced my work. In all of these projects, force-feedback haptic interfaces to computing environments were built and explored. These were also projects with which I was familiar; I could therefore draw information and expertise from the researchers involved.

Section 2.8 describes work on understanding haptic material properties and human haptic perception which influenced my thinking about the issues facing haptic simulation; and also directly affected my decision to examine texture and roughness.

Section 2.9 briefly discusses studies that attempt to characterize the perceptual space of haptic phenomena. One study deals with simulations of hard walls; another focuses on real textured surfaces. I also mention some studies that attempt to characterize a perceptual space across a wide range of visual textures. Each of these studies provides insight and models (of varying quality) for the enterprise of perceptually-based description of haptic texture and materials.

Section 2.10 briefly surveys other projects that have related goals but were not direct predecessors of this work. There are also several scientific and engineering fields that are important to haptics research historically, scientifically, methodologically, or technologically. I mention highlights from them to provide the reader with a useful starting point in locating reading materials and the names of key researchers.

Finally, Section 2.11 is a comprehensive table of haptic interaction devices and projects since 1965, with information on each project about its haptic interaction technology, and about the kinds of objects, sensations, and materials simulated.

2.7 History of Directly Related Haptic Interaction Projects

Since 1992 haptics has attracted a great deal of attention from researchers in several disciplines. At the start of my present work (1988) there were few other haptics projects worldwide. Haptics research is in a boom, and researchers in allied areas, such as robotics, are making explicit contributions to haptics.

Credit for first thinking about simulated haptic interaction goes to computer scientist Ivan Sutherland, who in his 1965 article “The Ultimate Display,” envisioned feeling forces at the surfaces of graphically displayed objects and beyond, using mechanical force-feedback devices. At the close of his article, he states “The ultimate display would, of course, be a room within which the computer can control the existence of matter. A chair displayed in such a room would be good enough to sit in.” [Sutherland65].

2.7.1 Atari Labs

My work evolved most closely from a chain of explorations of haptic interaction that started in 1983 at the Atari Cambridge Research Lab (ACRL).

At the ACRL, Max Behensky and Doug Milliken built a force-feedback joystick. Not only was it easy to design a simple direct-drive, force-feedback device in the form of a joystick, but we already had an interest in interactions with video games, which at that time were almost all joystick-operated. Behensky, Peter Cann, and others wrote software simulations of ideal springs, dampers and masses; maze walls; and a fishing game.

ACRL met an untimely end when Atari went bankrupt in 1984. Its haptics technology transferred in two directions: Atari Games and the Apple/MIT Media Lab Vivarium project

A proprietary version of a one-degree-of-freedom display (in the form of a steering wheel) was developed by Behensky and Milliken for Atari Games. This force-feedback steering wheel was used in a highly successful arcade game, *Hard Drivin'*, and its successor *Race Drivin'*. *Hard Drivin'* became the #1 grossing arcade driving game in the United States and Japan. The game pioneered the use of force-feedback haptics, which may have contributed to its success. Three other factors that also made the game good and should be kept in mind for all multi-modal systems are: 1) good-looking, fast 3D graphics, 2) digital sound with ambient and meaningful sounds at all times, and 3) an ambient open-ended environment consisting of a realistic track, a wild track, and a 3D landscape that could be explored in contrast with the more traditional driving game's restriction that one drive on the road.

2.7.2 Vivarium

Research on haptics continued at Vivarium, which started as a joint project between the neonate MIT Media Lab and Apple Computer. Behensky and Milliken created a second-generation joystick for the project in 1987; I used the same joystick for pilot work on texture at the University of North Carolina-Chapel Hill in 1989 [Minsky90]. Vivarium staff and students (including myself, Megan Smith, and Paul Dworkin) created demonstrations similar to those at Atari. Dworkin experimented with waves that move past the hand. Smith continued work on force-feedback by building an experimental one-degree-of-freedom motor-brake joystick [Smith88] [Russo88] and designing a three degree-of-freedom joystick. The three-axis joystick, which was re-designed, built, and characterized by Massimo Russo [Russo90a], was used in the experiments for this thesis (one of the three axes, an experimental cable-driven z-axis, was not used.)

The Vivarium project also funded two special-purpose force-feedback devices, which were built by Alec Brooks (of AeroVironment) and were intended to give the user direct experience with pterodactyl flight. The first device was a simple one-degree-of-freedom motor driving a lever on the shaft; the user pretended the lever was the head of the pterodactyl, steered it, and felt a simulation of the wind forces on the head. The second device was a motor-driven arm rig for the shoulder, elbow, and wrist for amplifying forces due to the user “flapping” her “wing”. The one-degree-of-freedom device was used in an exhibit at the Smithsonian Air and Space Museum.

2.7.3 UNC-Chapel Hill

Several projects at the University of North Carolina at Chapel Hill’s Department of Computer Science, under the leadership of F. P. Brooks, have been dedicated to understanding and harnessing haptics. One of Brooks’ key insights has been to structure the research around what he calls “driving problems”, usually in science, so that interaction research is always done in the context of an important problem faced by working scientists. He also ensures that scientists are users of the prototype systems.

Early work at UNC involved force-field simulation for teaching physics [Batter71] and early experiments with 3-degree-of-freedom haptic display of object surfaces [Kilpatrick76]. A very successful 6-degree-of-freedom haptic interface has been created in collaboration with a set of scientific designers. They are molecular biologists who design and analyze large molecules (mainly drugs and human protein enzymes). As all aspects of rational drug design have flourished, this arena has proven itself to be of great intellectual and practical interest [Brooks77,88,90] [Ouh-young90]. Recently, a haptic interface has been developed to aid in interaction with objects that are even smaller in scale. The forces from scanning tunneling microscopes are scaled to be directly perceived by a user [Taylor93].

2.7.4 Less Formal Early Influences on this Work

- I was drawn toward the enterprise of creating haptic displays for a rich set of materials, in part, through frustration with areas missing at the time from Logo: microworlds with connections to the external social and literary forms of our culture and microworlds beyond the turtle incorporating the sensuality of the body touching physical things. The Logo project has made great forays of its own recently into these areas; I found myself drawn into this world of enabling haptic technologies.
- The Media Lab, and its predecessor, the Architecture Machine Group have produced a body of work developing multimodal interfaces, using all the senses and potentially using whole body gestures, and physicalizing information spaces. Early examples are the Spatial Data Management System and Multi-sensory Interface [Bolt82].
- Bill Buxton constantly stresses perception-based approaches to using the body in computer interaction, supporting simple ideas such as using two hands rather than one [Buxton86].
- During the early part of this work I was encouraged by the inventiveness and can-do spirit at two haptics labs. They shared lots of useful information and demonstrations with me: C. Cadoz' s lab at Grenoble [Cadoz90, Cadoz&Luciani93] and H. Iwata's lab at Tsukuba [Iwata90,91,92a,b,93].

2.8 Haptic Perception

The line of research that I found most useful in understanding the rich phenomenology of haptics is the work of Lederman and Klatzky, which has led to the development of a theory of manual object exploration. Methodologically, this scientific approach rests on systematic observation of hand motion during object exploration, as well as a number of other experimental paradigms.

They have observed that people execute a set of highly stereotypical manual exploration patterns which they call "Exploratory Procedures (EP's)" associated with the recovery of haptic properties of objects. Their book chapter [Klatzky&Lederman90] is a particularly good summary. The EP associated with recovery of texture in object perception and recognition is known as Lateral Motion. In this EP the fingers move in a back-and-forth or circular rubbing pattern.

Results from their research approach support the concept that material and surface properties are highly salient haptic aspects of objects particularly when touch is used alone and object identity is not critical [Klatzky,Lederman,Reed87].

Lederman and her colleagues study human haptic perception and manipulation of objects and surfaces in situations that are highly abstracted (for example, the set of artificial multidimensional custom-designed objects in [Klatzky87] above) to isolate fundamental perceptual phenomena; these are shown, in turn, to be relevant in the perception and identification of real objects as well.

Roughness of texture as an isolated percept was studied and evaluated using a psychophysical methodology by Lederman in [Lederman72, Lederman74]. The results of those studies were particularly intriguing and at the time somewhat counterintuitive. The roughness of metal gratings was correlated with finger force normal to the surface and with the groove width of the gratings rather than the overall spatial period, as most had suspected.

I began exploratory research on the roughness of simulated textures with the premise that if I created analogs to Lederman's stimuli, I would also find that roughness was a scalable percept and that it would be revealing to look at the relationship between factors leading to roughness in the real world and those leading to roughness of simulated surfaces. In particular, I predicted that the relationship between roughness and groove width might not be present, since it might depend on the sensor mechanisms in the skin and that a different relationship between roughness and spatial features might hold. More specifically, I hypothesized that roughness would scale with the spatial period of a grating texture, since spatial period is potentially easily coded as the vibration frequency reaching the hand on the joystick.

The issue of whether we can model high-level haptic perception using data from sensory physiology and present-day knowledge of neural coding in these systems is problematic. Improvement in non-invasive techniques for investigating peripheral and cortical neural coding from haptic sensors will make it both more justifiable and easier to search for the underlying neural codes for haptic percepts.

There have been some models that attempt to integrate biomechanics, sensory physiology, and observed human haptic perceptual phenomena. For example, Lederman developed a quasi-static, biomechanical, skin-deformation model to account for her behavioral results on roughness perception that implicated the volume of skin deformed in the grooves under the fingertip.

The role of finger scanning (motion) in texture perception is highlighted by Lederman and Klatzky's observation of the Lateral Motion exploratory procedure associated with texture extraction. The notion that relative motion is a fundamental requirement for texture sensing has been noted by Katz [Katz25], and later work verifies that motion of either the finger or the surface is required for texture perception. A model of texture sensing which combines a computational approach with a biomechanical model shows that relative motion between skin and textured surface effectively increases the resolution of skin sensors, whatever their anatomical resolution [Drucker89].

Gibson [Gibson62] develops a philosophical distinction between active touch, with motion, and passive touch, with no motion. These are identified respectively with an *objective pole*, (perception of external objects) and a subjective pole (perception of sensation impinging on the subject). The notion of active touch emphasizes that in ordinary circumstances the purposive exploratory motions of a person are a prominent mode for haptic perception. Although the distinction is intriguing in general, it is also too extreme. For example, perception of textured surfaces does not require motion of the fingertip; motion of either fingertip or surface suffices.

In ordinary real-world situations, texture is usually scanned directly with the fingertip. When using our simulations, the situation is modeled more closely by scanning with a thin probe (stylus or stick) held in the hand. Clearly, the biomechanics and the sensory systems in these two modes of texture perception are quite different. Katz [Katz25] showed that people can identify several different types of paper when using a stick-like probe. There is little other research on haptic percep-

tion, particularly of texture, through a probe. It is possible that certain aspects of texture perception are mapped, perhaps at a cognitive level, by our haptic systems between information from sensing in probe mode and information that would result from sensing in the more usual fingertip mode. Certain details of texture perception, however, may not map in this way. For example, Lederman's result that roughness perception of grating surfaces depends upon the groove width of gratings may have no correlate in roughness perception of grating surfaces felt with a simulated probe, because recovery of groove width may be a phenomenon that depends on the biomechanics of touch with the skin of the finger.

2.9 Haptic (and Visual) Perceptual Spaces

Simulation of hard surfaces is a difficult engineering and control problem for force-feedback haptic displays, and it has been considered a "challenge problem" [Jex88], [Ouh-young90]. Rosenberg and Adelstein have attempted a *perceptual* classification of simulated hard surfaces [Rosenberg93]. They characterize hard surfaces in terms of hardness, crispness, and release cleanliness, and find that these percepts are modeled in a separable way by spring stiffness, damping constant, and directionality of damping (in their physical model, a spring constant and a damping constant can be separately adjusted near a the plane of a virtual wall). Thus perceptual aspects of a hard wall can be adjusted separately. The authors found that these perceptual considerations suggested the following improvement over their previous hard-wall models: a combination of an envelope around the virtual wall modeled as a viscous damper and a spring model close to the wall surface,

Yoshida [Yoshida68,69a,b] attempted to analyze the perceptual space of a variety of flat materials, and the feel of woolen textiles in particular, which varied according to physical and manufacturing parameters such as thread thickness and thread count,

In the realm of real-world texture, a notable recent study by Hollins [Hollins93] used a multidimensional scaling technique to verify that a space defined by textures of 17 common (real) objects plausibly fits a three-dimensional texture space. The dimensions seem to correspond to: smoothness-roughness (subject rated), hardness-softness (subject rated), and possibly springiness. The authors compared the experimental space to subjects' verbal ratings of the same textures along dimensions of smooth-rough, hard-soft, slippery-sticky, flat-bumpy, and warm-cool. One problem with this study is that the touching activity was quite restricted compared to naturalistic exploration because the subject's finger was still and textured objects were stroked across it. Still, this study provides important evidence for a dimensioned space of texture properties, making a *perceptually-based* representation plausible.

Although we did not have the opportunity in this dissertation to investigate the relationship of haptic to visual texture perception, we note that the equivalent problem of characterizing visual-perception texture space is a focus of active research. A study that aimed at producing a texture-naming system for computer environments and telecommunication used 56 visual textures from the Brodatz database to span a perceptual space [Rao93]. Subjects rated the textures on descriptive scales and also sorted them into similarity groups. Analyses of both kinds of data yielded a three-dimensional perceptual space for texture, characterized as 1) repetitive/non-repetitive 2) high-contrast and non-directional/low-contrast and directional and 3) granular, coarse and low complexity/non-granular, fine, and high-complexity. Another study, aimed at producing computational pattern-recognition primitives for natural textures, used 16 Brodatz textures. Subjects made similarity judgements on 6 descriptive scales (coarseness, contrast, directionality, line-likeness, regularity, and roughness) and found closest-neighbors in the texture space [Tamura78]. The authors found that judgements on the descriptive scales were fairly well correlated across subjects, and that roughness was highly correlated with coarseness and contrast, but that closest-neighbor judge-

ments were highly variable, depending upon different criteria and sometimes upon global texture features and other times upon features of texture elements.

2.10 Surveys

What follows is a survey of surveys! The reader will find useful background research and information about current practice in haptics within the survey papers noted in this section. Other papers that have proved especially influential and helpful are highlighted in the Annotated Bibliography.

2.10.1 Definitions of Haptics

Haptics refers to what is informally called the sense of touch and motor behaviors associated with touching. The haptic senses are a complex organization of systems: skin (cutaneous) sensing, which is mediated by a variety of sensing organs that respond to pressure, vibration, displacement, and temperature; kinesthetic and proprioceptive sensing (mostly in muscles and joints), which respond to motions and forces exerted by the interaction of the body and the external environment; and motor activities. Brooks uses a dictionary definition¹ in a summary paper on haptics interaction projects: “pertaining to sensations such as touch, temperature, pressure, etc. mediated by skin, muscle, tendon, or joint.” [Brooks90].

2.10.2 Cutaneous Sensing

The physiology and sensory phenomenology of skin sensors are surveyed comprehensively by Sherrick and Cholewiak [Sherrick86].

1. *Webster's New International Dictionary*, 2nd Edition, Merriam: Springfield, Massachusetts

2.10.3 Tactile Arrays

A survey of tactile-array technologies has been developed for creating analogs of visual images on the skin and for simulating haptic sensations by stimulating the skin sensors. Technologies include vibrotactile, electrotactile, and deforming arrays. There are recent surveys by Shimoga [Shimoga93a], and Kaczmarek [in press].

2.10.4 Proprioception and Kinesthesia

The best survey is still Clark and Horch [Clark86].

2.10.5 Texture perception

There is no comprehensive survey. The best compendium is in Loomis and Lederman's survey Tactual Perception [Loomis&Lederman86]. However, there has been considerable research since that date. For research in neural correlates of texture perception from the literature in neurophysiology and perceptual psychology, the reader is also referred to the published papers of Lederman (perception); Johnson, Hsaio and their colleagues; and Goodwin and colleagues.

2.10.6 Haptic interaction with computer environments and hand-based input/output

In the past few years, several surveys have been published on haptic interaction technologies and on a related area, the role of the hand in human-computer interaction. Some interaction devices are reviewed in Foley's Scientific American article [Foley87]. A very rich introduction to the use of the hand is in Sturman's doctoral thesis "Whole-Hand Input" [Sturman92]. Sturman also references some of the relevant literature on gestural human-computer interaction (HCI) and gestural communication. The best recent surveys of haptic interaction technology are from the VETREC consortium report [Salisbury92], and Shimoga [Shimoga93b]. Shimoga concentrates on hand-mounted and anthropomorphic devices. Useful survey information can also be found in a cumula-

tive report by Brooks on UNC's investigations [Brooks90] and in the introductory sections of theses by Smith, Russo, and Ouh-young. A popular account of several projects world-wide, with a selected bibliography, is provided in Rheingold's book *Virtual Reality* [Rheingold91].

2.10.7 Robotics and Teleoperation

The teleoperator-research community from its inception has had an implicit relationship with haptics. One way to think of haptic simulation environments is as teleoperation with the slave side replaced by a simulation. F. P. Brooks at the University of North Carolina at Chapel Hill first articulated this insight for the series of research projects there [Brooks90]. At this time, there is no ideal concise survey of the applications of robotics and teleoperation lessons to haptic simulations. There is a wealth of useful information in Sheridan's book, "Teleoperation, Automation, and Human Supervisory Control" [Sheridan92].

2.11 Summary of Haptic Interaction Projects

Table 1 below is a summary of haptic interaction projects. This complements other summaries in the literature. First, it is more comprehensive, Second, if possible, I have noted the kinds of sensations, objects, and materials simulated in each project. Some of the interface technologies may, of course, be capable of simulating a wider variety of haptic materials.

This table is comprehensive for force-feedback devices specifically used for haptic simulation, both published and unpublished (please let me know if it is not!), It does *not* attempt to cover tactile displays and arrays, nor thermal interfaces. I have included my favorite (and the most relevant) devices used primarily for teleoperation rather than haptic simulation. I have also included what I consider relevant exotic haptic technology, such as a wind machine.

In the next chapter, I discuss my work on haptic simulation for force-feedback display, with particular emphasis on the simulation of texture.

TABLE 1. Haptic Interaction projects

Year(s)	Author Lab or Company	Display	Type dofs	Typical materials or objects simulated
1965	Sutherland @ Utah	<i>The Ultimate Display</i> paper	concept paper	force fields; general object simulation
1971	Batter and Brooks @UNC	GROPE-1	cartesian 2D	interparticle forces e.g. $1/r$, $1/r^2$
1971	Noll @ Brooklyn Tech	Man-Machine Tactile	cartesian 3D	hard surface cube, sphere
1976	Kilpatrick @ UNC	GROPE-II	3D (Goertz manipulator arm)	hard surfaces of cube, other polygonal modeled objects?
1977	Atkinson et. al. @ USDC	Touchy-Feely	3D cable tetrahedron	force fields
c. 1980	Standhammer@FSU.	Joysting	3D cable tetrahedron	used by Feldman at NIH
1983	Atari Labs , Cambridge	Force-Feedback Joystick	2D joystick	springs, hard wall, maze walls, fish forces
1982	Bolt, Agronin @ MIT Media Lab	Multi-Sensory:	1D slide + 1D tilt, vibrotactile pin array, prototype temp cell	surfaces with vibrotactile texture
1988	Brodey @Teletouch	Teletouch	pneumatic pillows	controllers for machinery
1987	A. Brooks @ Aerovironment	Pterodactyl	1 dof prototype and exoskeleton with 2 dof shoulder, 1 dof elbow, 1 dof wrist	pterodactyl flight forces on human arm joints
1989	Adelstein @ MIT Mech E	Joystick	2 dof motor joystick	walls, textbook objects, stabilized stylus
1988	Smith @ MIT Mech E	1D motor-brake joystick	1D joystick with velocity and force sensor	textbook objects, water balloon, hard wall
1988	Russo @ MIT Mech E	3D joystick	3D joystick with motor, brake, force sensor	textbook objects, trajectories
1989	Minsky, Steele @ UNC and MIT	Sandpaper	integrated system uses Milliken and Russo 2D joysticks	textbook objects, textured surfaces
1989	Atari Games	Hard Drivin' Race Drivin'	Arcade games with 1 dof force feedback steering wheel, pedals and shifter	steering wheel uses real car dynamics to feel steering and interaction with road
1987	Jacobsen @ U. of Utah and Sarcos	NOSC & Sarcos Arms	22 dof arm + hand	submarine and other teleoperation applications
1990	Cadoz, Luciani @ Grenoble	Modular Feedback Keyboard Cordis Anima System	16 tap motor	piano key, string instrument bow, ensembles of particles

Year(s)	Author Lab or Company	Display	Type dofs	Typical materials or objects simulated
1990	Ming Ouh-young @ UNC-Chapel Hill	GROPE-III	6 dof robot arm	Force fields due to forces between two non-bonded molecules
1990	Iwata et al @ Tsukuba	Compact Master Manipulator	6 dof global, thumb, index finger, other fingers	hard and compliant eg modeled objects, 1D textured profiles
1991		StairClimber	cables pull each foot on skates, counterweighted	climbing stairs
1991		Texture Key	1 dof telegraph key	surface contours
1992		Pen	6 dof	writing in 3D, deformation of surface, pushbuttons
	Hennequin	Pneumatic Hand	pneumatic pillows	not known
1990	Burdea et al @ Rutgers	Portable and New Hand Master	2 and 3 pneumatic finger controller	spring and simple compliant 3D objects.
1990	Chin @ MIT Man-Machine Systems	Incision Simulator	1 dof lever on motor shaft	visco-elastic model of skin layers
1991	Hannaford @ U. Washington	Force Scaling μ manipulator	not known	probe and pick up small objects
1991	ATR Labs, Japan	MultiModal Interface	3 dof desk mount arm	not known
1991	EXOS Corp. (Marcus et al.)	SaFire; Force ArmMaster; HEHD; PowerStick	2 dof wrist, 2 dof index finger, 3 dof thumb; 3 dof shoulder, wibow, forearm; 4 dof hand; 2 dof joystick; all motor driven	pick and place application, textbook objects and walls
1991	Jones, Hunter	not known	not known	stiffness and damping tests; eye surgery simulation
1992	Hirose et al @ Tokyo	Magnetic Surface Display	3 dof tracker plus pressure applying pad	walls, compliant walls of polygonal 3D objects
1992		Wind Display	12 muffin fans on hand held mount	windtunnel airflow
1994		Moldable surface	multiple rod actuator array under flexible surface	3D surfaces, hard and compliant
1992	Tachi @ Tokyo	Anthropomorphic Arm	not known	not known
1992	Gillespie @ Stanford	Touchback Keyboard	1 dof motor actuator	piano action, bouncing ball, textbook objects, rigid mechanical linkages
1992	Jacobus @ CyberNet	name unknown	6 dof arm	molecule forces, tank vehicle-driving forces

Year(s)	Author Lab or Company	Display	Type dofs	Typical materials or objects simulated
1992	Sato et al @Tokyo Tech	SPIDAR, SPIDARII	1 finger 3D brake driven cables; 2 finger 3D motor cables	Virtual clay on potter's wheel, virtual wooden blocks
1993	Colgate, Millman @ NorthWestern	4 DOF manipulator	3 dof + plane rotation of handle	tool use: e.g. tighten bolt
1993	Wallace @ NYU	Phone Squeeze	2 flippers	limited touch over phone line
1992	Srinivasan et al @ MIT-RLE	linear grasper; planar grasper; instrumented screwdriver	1 dof; x, y plus twist; brake driven screwdriver handle	textbook objects; torque-friction screwdriver simulation
1993	Taylor@UNC	Nanomanipulator	UNC GROPE arm	force fields generated by surface in a scanning probe microscope
1993	Rosenberg @ Stanford	Haptic Fixtures	integrated system uses 2dof joystick (Adelstein's)	spring, dampers, walls, sinusoid grating texture
1993	Massie, Salisbury @ MIT AI Lab and Sens-Able Devices	PHANTOM	3 dof motor-driven arm	3D textbook objects, spheres and polygonal objects, push-buttons, textures, friction models
1994	Howe	manipulators	2 dof planar (also tactile display)	teleoperation with multiple fingers
1995	Immersion Corporation	Impulse Engine 1000, 2000, 3000, and Laparoscopic	1dof linear, 2dof joystick, 3dof, and surgical simulator	epidural anesthesia procedure

3 Dynamics and Textures in the Sandpaper System

3.1 Introduction

In this chapter I introduce and describe techniques for force-feedback display of texture and the software system *Sandpaper*, which is an interface to simulated textured objects.

- Section 3.2 describes the *Sandpaper* interaction system for, feeling, testing, and investigating simulated haptic materials, dynamic regimes, and objects.¹ The user interaction paradigm and features of the *Sandpaper* system are described along with of the haptic materials, regimes, and objects that were simulated in the early part of this investigation.
- Section 3.3 reviews the basics of haptic display using force-reflection techniques with a joystick as the hardware interface. The approach here has its precedents in previous work, from both seat-of-the-pants and formal mechanical engineering traditions (at Atari Cambridge Lab, UNC-Chapel Hill [Kilpatrick76], [Ouh-young90], [Brooks90], and other labs). A mechanical system that is to be simulated is analyzed and equations of motion are developed. A numerical solution controls the mechanical impedance of the joystick system. This approach has been used by both practitioners with empirical and theoretical bases and analyzed extensively by Hogan [Hogan85a,b,c, Hogan90c].
- Section 3.4 describes the lateral-force algorithm for texture simulation, which is the technique used in most of this investigation.
- Section 3.5 describes and illustrates the textures chosen for the formal experimental part of this research.
- Section 3.6 discusses characteristics, limitations of this approach to texture simulation, and artifacts of this implementation.

3.2 Sandpaper System: Software is in Control

The *Sandpaper* software system has been designed to make it easy to implement simulated mechanical regimes, feel them with the joystick, see a visual representation of them, and modify their simulation parameters. *Sandpaper* can maintain an arbitrary number of “patches” of simulated material, each of which has an independent simulation program. This organization is sug-

1. I designed *Sandpaper* in collaboration with Oliver Steele and David Banks, both at University of North Carolina-Chapel Hill. It was implemented largely by Steele.

gested by object-oriented programming systems, in which objects (in this case, classes of patches of material) maintain state.

The Sandpaper system maintains a set of patches that have access to common information, in particular, to the joystick's position, velocity, and acceleration, and to filtered versions of these variables. Each patch is associated with a block of code that implements its particular dynamics model and exports a set of changeable parameters (e.g., \mathbf{m} , \mathbf{b} , and \mathbf{k} in the textbook object model described in section 3.3) to the user interface so that the model may be varied interactively.

The code block of each patch implements whatever controller is desired. Thus, these controllers are fully digital and are implemented to run in the same software environment as the dynamics simulation, the user interface, and the graphic display. For particular controllers and simulations, this approach gives great flexibility, at the expense of speed.

3.2.1 Design Criteria fulfilled by *Sandpaper*

The Sandpaper system was designed so that each of the following things can be *independently* varied for each "patch" of material, simply by writing C code local to that patch. All of these goals have been accomplished in the current implementation:

- Dynamics of objects or regimes within a patch
- Control algorithm for haptic output
- Visual representation of a patch
- Export of simulation parameters to user interface

Thus a researcher can code an algorithm for the "feel" of a patch as a simple, small C module, and test it alongside pre-existing patches for comparison.

Multiple patches can have the same dynamics and control scheme but different mechanical parameters, gains, and filters. (For example, there can be a class of patches simulating a brick hanging

from a spring; each such patch can have independently variable brick mass, spring constant, and displayed brick color.)

Any patch code can independently access joystick state inputs, filtered state inputs, and arrays of auxiliary data (such as height maps and force fields).

The system interface is tuned for use in perception experiments. Patches have a visual appearance and can be moved like physical pieces of material. The experimenter can see where the user is exploring with a joystick position cursor. The patch that is being “touched” is selected, and its simulation parameters are automatically exported to a set of sliders on the screen. These parameters can then be adjusted in real-time by either the experimenter or the user, depending on the needs of particular perception experiments.

Figure 3 is an illustration of a typical screen configuration of the Sandpaper system:

FIGURE 3. Screen from *Sandpaper* system

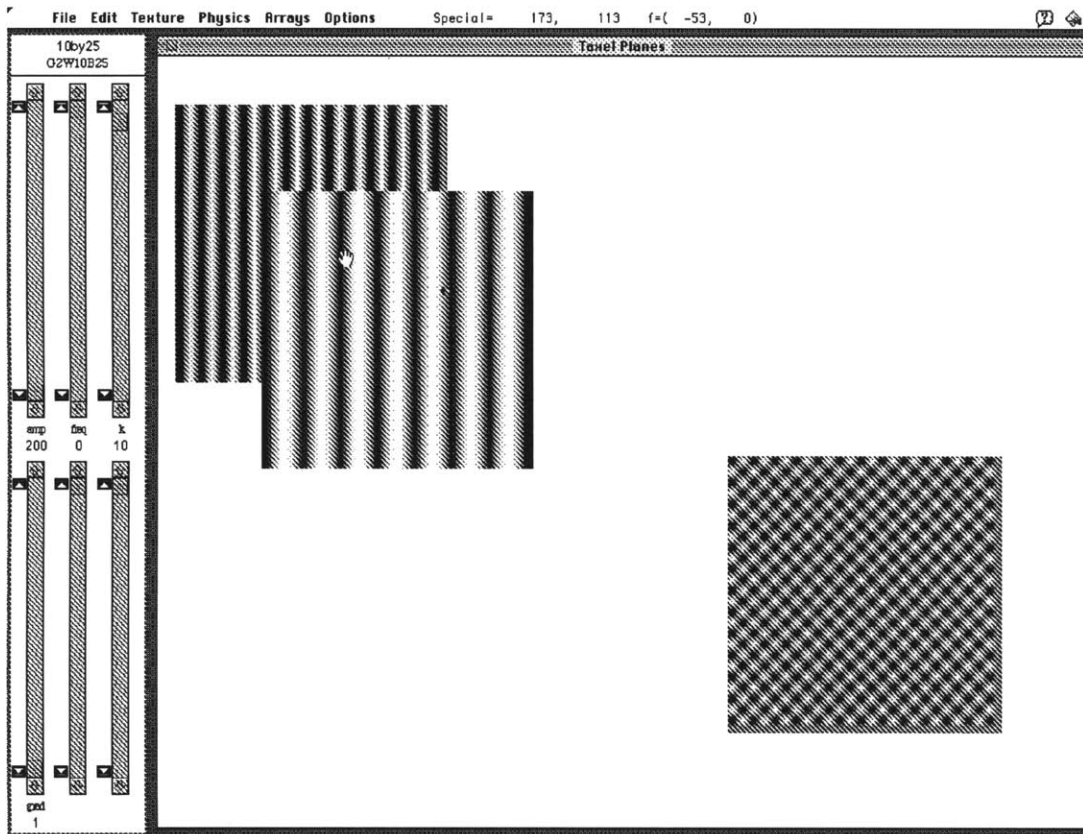

For detailed information on the commands and capabilities of *Sandpaper*'s user interface, see Appendix B, *Sandpaper* Quick Reference Guide.

3.2.2 Sandpaper System Modules

This section lists the classes of haptically displayed materials, objects, and regimes created for this research and installed into Sandpaper system. The rest of the dissertation concentrates on one par-

ticular class of these haptic objects, namely *textured surfaces* simulated with the *lateral-force gradient algorithm*.

Within the *Sandpaper* system, modules corresponding to surfaces were easy to build and manipulate on the screen. Some were built as stepping stones along the way to finding a valid simulation for texture. Some were built to test whether this system was general-purpose enough to simulate a wide variety of mechanical regimes and objects. Others were built to test haptic interfaces for applications, such as touch desktop, and haptic interpretation of medical images.¹

Dynamic Modules are dynamic simulations of masses, springs, and dampers

Examples include one point-mass and two point-masses coupled to the user by springs; moving masses; linear springs (along a line) and radial springs (spring forces in all directions from a central point). Real-time animations of the one- and two-mass simulations were visible along with the haptic simulation.

An **Attractor** is a dynamic simulation that couples the user's hand, through a spring, to a light object moving along a swirling trajectory.

Synthetic Force Profiles are simple synthetic contoured surfaces ("textures") with periodic lateral force profiles.

Examples are a sawtooth wave and sinusoidal force function. These are ad hoc models of contoured surfaces, since they are neither derived from a natural physical surface nor from perceptual considerations. These models can create the haptic sensation of regular features, or of texture at small size. They are easy to implement and have provided a robust testbed for experimentation:

1. Modules built by Margaret Minsky, Oliver Steele, David Banks.

other investigators with various hardware devices have implemented similar simulations of “texture” or surface features, for example [Iwata91b], [Rosenberg93].

Synthetic Lateral-Force Gradient Textures are textures displayed from height maps using the lateral-force gradient algorithm. The underlying height maps are from both simple and complex synthetic models. Examples include regular gratings, regular grids, and irregular “Perlin” textures. These are all used in the experiment in Chapter 4. Another example of underlying height maps are irregular noise textures originally generated for research in visual texture synthesis [Picard92]. Surfaces that define large-scale objects in bas-relief can also be displayed using this algorithm. For example, we displayed an image of a teapot; its height map was processed from a polygonal surface representation.¹

Lateral-Force Gradient Textures from Real-World Data are textures displayed using the lateral-force gradient algorithm, using underlying height maps from real images (We tried medical images², electron micrographs, and a small selection of textures from the Brodatz book of visual textures [Brodatz66].)

Synthetic High-Resolution Lateral-Force Profiles are regular textures from a spatially high-resolution seed consisting of a single hill-valley cycle of a grating. Grating textures are generated from this seed at a wide range of feature sizes by reproducing the seed with appropriate spatial size.

1. Teapot processing by Matt Fitzgibbon of University of North Carolina at Chapel Hill.

2. “‘You never dreamed I could reach through a phone screen to do *this*.’ I reached into his head, felt smooth muscle and grainy bone and sinus cavities like bubbles. He tossed his head, but my hand went with it. I ran imaginary fingertips along the smooth inner surface of his skull. It was there. A ridge of scar, barely raised above the rest of the bone, too fine for X-rays. It ran in a closed curve from the base of his skull up through the temples to intersect his eye sockets. ‘It’s him,’ I said.” from *The Long Arm of Gil Hamilton*, Larry Niven, 1976.

Materials are dynamic regimes that simulate material properties, such as pure viscous fluid, pure negative viscous substance (called “anti-viscous”) and jittery regimes. Pure springs can be thought of as compliant materials in the x or y directions.

MGrav, a haptic desktop: While not strictly speaking a *Sandpaper* module, experiments were conducted on the use of spring detents¹ to provide haptic cues for menu items and window edges in a desktop like the Mac Finder². Section 7.7.5 contains some additional speculations on uses of haptic cues to directly enhance present-day user interfaces.

3.3 Basic Force Feedback

Force-feedback simulations are intended to feel like real objects and materials. They interact with the user through robotic devices that apply forces to the hand or body of the user; the basic strategy is to simulate the dynamics of the objects or materials being touched. Early approaches to this problem, [Noll72b], [Kilpatrick76], emphasize touching object surfaces; the problem becomes one of allowing the hand to stably contact a hard surface. The approach suggested by Behensky’s experiments at Atari Labs in 1984 concentrated on creating dynamics simulations, for example, springs, dampers, and inertial masses that could be manipulated by the hand.

3.3.1 : Textbook objects

I coined the phrase *textbook objects* (used in e.g. [Smith88]) for these regimes to emphasize that simple versions of Newtonian dynamics equations used in textbooks to represent *ideal* springs, dampers, and masses lead to “feel-able” versions of those objects.

1. Detent: a mechanism that locks or unlocks a movement [Webster’s]
2. *Mgrav* designed and implemented by O. Steele.

The Sandpaper system uses cartesian joysticks whose state (position, velocity, and acceleration) is detected and whose output force is controlled by torque motors. For the two degrees-of-freedom case the joystick axes of motion are independent to the first order. Thus we can consider a single axis, x , without loss of generality. The “textbook” spring is implemented via:

$$\text{force} = -kx \tag{EQ 1}$$

a viscous damper via:

$$\text{force} = b\dot{x} \tag{EQ 2}$$

and an inertial mass via:

$$\text{force} = m\ddot{x} \tag{EQ 3}$$

A block diagram (Figure 4) illustrates the inputs and outputs available to the software from the joystick, shown for the two degree-of-freedom joystick with x and y axes separated:

FIGURE 4. Block diagram of joystick/Sandpaper system

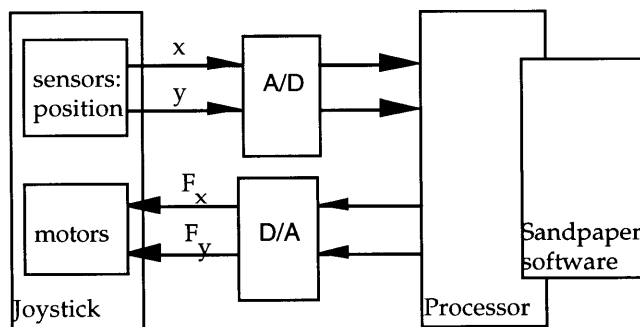

Control of the mechanical parameters k (stiffness), b (damping), and m (inertia), in order to control the apparent behavior of the joystick system, when held by a user, is called impedance control.

The notion is that for force display, one can model physical systems by their mechanical impedance. “A mechanical impedance is a dynamic operator which specifies the forces an object generates in response to imposed motions [Hogan90].” A second-order model (that is, a model built from equations 1, 2, and 3 above) is adequate for modeling dynamics of simulated objects and the interaction of object dynamics with the human arm [Hogan85, Hogan90, Sheridan92].¹ Note that in general, k , b , and m need not be linear functions of position or time.

Thus the local conditions for any simulation can be created using the combined equations of motion in the form:

$$\text{force} = M\ddot{x} + B\dot{x} + Kx \quad (\text{EQ 4})$$

where M is the mass of the simulated object, B is the simulated damping coefficient, and K is simulated stiffness.

3.3.2 Equations of motion

The equations of motion in this form (and with these boundary conditions) must be derived for each particular system to be modeled. In the simulations for this research, the equations were derived by hand inspection of the system model. Further work in deriving equations of motion for more complex dynamic regimes has been performed for rigid bodies within the context of haptic displays, by [Colgate88], [Hogan85a,b,c], and Milliken&Behensky (see [Simanaitis89]). Particularly notable is Gillespie’s work [Gillespie93] in which a novel method for deriving the equations of motion (Kane’s method) is used. This allows automatic, fast derivation of equations of motion, for complex mechanical linkages with constraints, suitable for use in haptic simulations.

1. The dynamics of the human arm itself are complex, and there is controversy over the level of modeling appropriate to describe it. In many situations a second order model is appropriate, however compare work by [Hannaford89] which suggest a need for higher order models for human arm behavior.

The fidelity and stability of simulations has been analyzed for certain cases [see Ouh-young90]. Stability of the simulated system has been the main criterion of success for virtual objects and their dynamics. Colgate, in [Colgate89], has proposed that the general success criterion leading to stable and robust simulations for haptic display is passivity of the system. For stability in contact with the user, the simulated system must locally appear to be passive, that is, it cannot supply power indefinitely.

3.3.3 Sandpaper System Characteristics

Table 2 summarizes the performance characteristics of the *Sandpaper* system.

TABLE 2. Sandpaper System Characteristics Summary

Screen display size	7" x 6"
Screen resolution	489 x 425 pixels
Joystick Workspace Size	9" circle
Joystick Position Resolution	12 bit each, x and y
Force output range	0-10 N
Force output resolution	12 bit
Simulation speed	900 Hz (updates/sec)

One of the current tradeoffs in haptic display is between simulation complexity and simulation update rate. We have found that digital update rates below approximately 1KHz lead to degradation in the and fidelity of simulations of textures. Our typical rate of 900 Hz is within this approxi-

mate range. We were careful to tune our software so that textures could be displayed for psychophysical experiments at this rate, using our existing hardware/software configuration.

3.4 Lateral-Force Textures: Implementation of Textured Surfaces

The main algorithm for simulated texture presented in this thesis evolved from the observation that sideways spring forces can feel like downward forces. A spring potential field, represented by Equation (EQ 1) above, feels to many users like a deep valley with a center at the rest position of the spring. A hypothetical explanation for this is that, at some level of the human haptic system, there is an analogy between having the hand *pulled* downward by gravity (into a valley) and having the hand *pulled* toward a point of rest (the center of the spring potential field). This observation led Behensky to create “simulated detents” for a video game switch panel by using many small simulated spring potential fields.¹ The center of each spring field *feels* to the user like a detent or small notch. This led me to try a spring-based representation of a wavy texture,² in which lateral forces toward “valleys” give the user the impression that the valleys are the low points of a textured surface.

Here is a different, more rigorous model of a physical situation in which sideways forces are produced from motion over a textured surface. Consider the joystick to be analogous to a stylus which is gripped by the user. The tip of the stylus moves over the textured surface and the user obtains some information about the texture through the fingers and hand. Now, imagine that the forces that the user can feel are restricted to *only* the lateral forces on the stylus. This could be done by restricting the user to lateral motion, keeping the hand at a constant height. Our imaginary stylus

1. Behensky, Max. Atari Games, personal communication. The game is “Hard Drivin”.

2. S. Benton points out that lateral forces are the detent cues felt on real old-fashioned knobs mounted vertically on panels [personal communication].

telescopes to accommodate the variations in height of the textured surface. The user's hand feels only the lateral forces due to the hills and valleys of the textured surface.¹

These sideways forces are the same as the forces generated by my algorithm, though the algorithm historically was developed from the spring model. We will now derive these forces analytically from the stylus model. This analysis may shed light on the relationship between haptic perception mediated by the joystick and people's ability to feel real-world texture through a stylus or stick.

Figure 5 shows a model of the joystick as a stylus rolling on a hilly surface. The hand grasps a stylus which rolls and telescopes so that the hand feels only lateral forces resisting the stylus' motion. A small part of a hill is shown, and the figure shows the stylus at two positions, x_1 and x_2 . The hand is held at a constant height as it moves and the stylus telescopes freely to accommodate the length between the hand and the surface. This length is illustrated as l_1 and l_2 . The sideways force the user feels as the stylus moves up the hill is calculated. This force is proportional to the slope of the hill. This is one physical model in which sideways forces proportional to the local slope of a textured surface would be felt by a person holding such a telescoping pen. Here is a derivation of the sideways force values (derived for x only, x and y are independent), assuming frictionless rolling and negligible moment of inertia of the rolling element at the stylus tip:

1. In the real world, this could be done by slipping a stylus shaft through a linear bearing; the user's hand now grips the linear bearing sheath. The tip of the stylus is considered to have low friction over the textured surface; imagine the tip is a rolling ball-point or a graphite pencil tip. As the user moves this stylus over a textured surface, only sideways forces are transmitted to the hand because the linear bearing rides freely along the length of the stylus, eliminating upward and downward forces. This linear bearing implementation was suggested by Barry Wolf [personal communication].

FIGURE 5. Stylus on a small hill

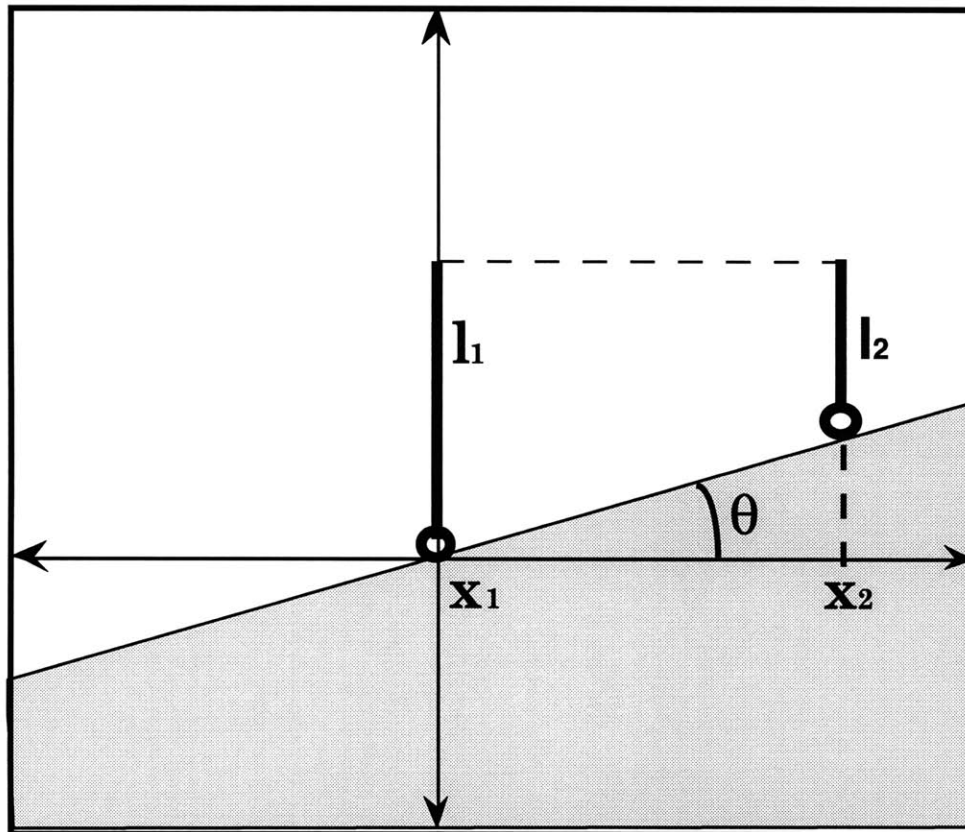

The basic principle used here is: the change in potential energy of the stylus as it moves on the textured surface is equal to the work done to move it. The only acting external force is gravity.

$$\Delta PE = \text{work} = F \cdot d \quad (\text{EQ 5})$$

where F is the force in the lateral x direction and d is the distance moved, We need consider only the x coordinate because the x and y axes (and forces) are orthogonal and thus independent.

now,

$$\Delta PE = PE_2 - PE_1 = ((l_1 - l_2) mg) - 0 = (l_1 - l_2) mg \quad (\text{EQ 6})$$

where PE_1 is the potential energy at x_1 , PE_2 is the potential energy at x_2 , g is the acceleration due to gravity, and m is the combined mass of the stylus and the user's hand.

The distance, d , is

$$d = x_2 - x_1 \quad (\text{EQ 7})$$

From Figure 5, we also have:

$$\frac{(l_1 - l_2)}{(x_2 - x_1)} = \tan \theta \quad (\text{EQ 8})$$

Substituting into Equation (EQ 5), we obtain:

$$(l_1 - l_2) mg = F \cdot (x_2 - x_1) \quad (\text{EQ 9})$$

$$(x_2 - x_1) \tan \theta mg = F \cdot (x_2 - x_1) \quad (\text{EQ 10})$$

$$F = mg \tan \theta \quad (\text{EQ 11})$$

It is plausible that a person could feel texture mediated through such a telescoping stylus, since people can sense surface texture through a plain stylus. I suggest trying an informal test with an equivalent apparatus, constructed as in footnote 1., page 49, from a pen and linear bearing.

Thus, the *gradient algorithm* for simulated texture can be arrived at in two ways: either as the outcome of a physical model or the extension of the perceptual observation that sideways spring

forces feel like gravity acting on the hand. The former model helps justify the texture algorithm in terms of a physical situation, the latter model explains how I thought of this algorithm. I now discuss its implementation for producing the impression of surface texture.

Figure 6 is a cross-section of a texture with regular, small, sharp waves, called a regular triangle wave. One axis is shown; a texture with a grid structure is produced by using the same cross-section independently for both x and y directions. The wavelength is the distance of a spatial cycle of this texture, peak to peak.

FIGURE 6. Procedural triangle wave texture

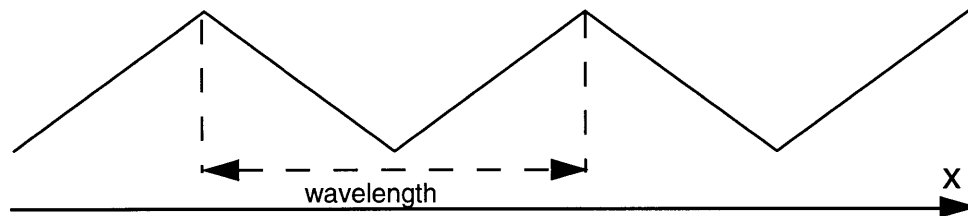

Sandpaper patches automatically have access to the joystick state (in this case J_x and J_y represent the joystick position), and run a loop that exports the prescribed forces (`force.x` and `force.y`) to the joystick. Thus, to implement the triangle wave texture, a patch class is defined called `Triangle` which uses the following C code:

```
/*Triangle Wave Texture*/

/* Force is proportional to distance from local wave center. A triangle
wave is computed implicitly here with maximum force of amp and spatial
frequency freq. These are ramps of length wavelength, broken into triangles
using the absolute value function abs*/
int wavelength = 1000/freq;

force.x =(abs ((Jx % wavelength) * amp/wavelength) -amp);
```

```
force.y = (abs ((Jy % wavelength) * amp/wavelength) -amp);
```

In this example, each spring potential field is *not* explicitly coded in terms of stiffness and rest position. Rather, linear ramps in the output force are implicitly generated, as the joystick is moved along a line. The set of linear ramps is a triangle wave; thus, each triangle represents a local spring potential.

This exercise led to an algorithm (developed by my team while at the University of North Carolina at Chapel Hill) for producing texture based on pre-existing height maps of small features similar to the geometry of real textured materials. If the bumps in the height map are considered to be local potential fields, with flat regions (valleys and plateaus) at zero potential and steep slope between valleys and hills at high potential, then a spring force proportional to the local slope represents the potential, and thus should feel like an appropriate force “down” toward the center of each local valley. The algorithm simply outputs the sideways forces proportional to the local vector gradient of the texture height map. This is called the *lateral-force gradient algorithm* for texture.

We consider two-dimensional texture defined as having a height $h(x,y)$ at every point (x,y) . The gradient algorithm gives output forces calculated in Equation (EQ 12) and Equation (EQ 13)¹. The x and y forces, $f(x)$ and $f(y)$ are orthogonal and are computed independently. The constant k allows scaling of the local spring potential.

$$f_x = k(h_{(x+1)} - h_{(x-1)}) \quad \text{(EQ 12)}$$

$$f_y = k(h_{(y+1)} - h_{(y-1)}) \quad \text{(EQ 13)}$$

1. Note that a surface can be defined by either a continuous or discrete description; the equations show discretized sampling in x and y for calculating local gradients.

Although this model was suggested by the feeling of a spring potential, there is no guarantee that there are true linear spring potentials over a large area of texture. Only if the texture data themselves include linear slopes will there be a simulation of a linear spring toward the bottom of the slope. Locally, of course, the potential is linear (from the equation above). However, a typical small bump that is part of a simulated texture may have a more complex shape than a linear slope, and we thus consider the potential at the top of those bumps to be non-linear springs.

3.5 Textures for Experiments

To investigate human perception of simulated texture, sets of Sandpaper patches were created for users to feel. The investigation procedures and results are detailed in Chapters 3, 4, and 5. These texture patches were modeled with features analogous to geometries of real textured materials.

3.5.1 Textures from Surface Geometry I

I developed a set of eight-bit height maps of features. *Gratings* are alternating linear raised bars and valleys. *Grids* are raised bumps and valleys in a checker-board pattern.

Feature sizes range from .37 mm to 18.5 mm. The feature size for regular textures is defined as the spatial period (distance from a bump peak to the next bump peak). For Perlin textures it is defined as the size of an underlying lattice.

The grating and grid height maps were then smoothed by filtering the eight-bit height array with a two-dimensional Gaussian filter with a kernel size appropriate to the size of the grating or grid pattern. This particular smoothing filter was chosen for two reasons. First, it is plausible that a Gaussian contour might approximate a wide variety of natural processes that might be applied to real materials. Thus the shape of the bumps and valleys, while not designed to model any specific real material or shaping process, might serve as a generic representation of real materials. Second, the

technology for this filtering step was easily available in the computing environment and would be available to other researchers preparing synthetic textures.

Perlin textures are named for their inventor, Ken Perlin. They are height maps derived from his solid noise textures [Perlin85]. Perlin's algorithm for solid noise generation assigns a value between 0 and 1 to each control point on a cubic grid, and uses tricubic interpolation of the control point values to assign each location in the gridded space with a density value between 0 and 1. We construct a height map by intersecting the lattice at the plane $z = 0.5$, to produce a plane of density values; by sampling that plane at pixel locations within a rectangle; and then reinterpreting each sampled density value as a height. The size of the lattice grid determines the feature size of the Perlin texture.

Perlin textures were chosen because they can be generated easily at different sizes, are highly irregular yet smooth, and generate textures that look irregular and "naturalistic" to the human visual system [Perlin85].

These smoothed height maps were used together with the lateral-force gradient model to create haptic display. This is called the Version-1 texture set, and it was used in the experiment described in Chapter 4. Appendix A shows the Version-1 texture set height maps.

The Version-1 set consists of analogs to texture elements that have been used in studies of roughness perception, including gratings.

3.5.2 Textures from Surface Geometry II

For the experiments detailed in Chapters 4 and 5, an alteration was made to improve the resolution of the height maps and to extend the range of textures to those with smaller feature sizes. This experiment used only grating textures, which are the same on every horizontal line. Rather than

creating a full square two-dimensional array, we made a thin rectangle. The rectangle is 256 pixels wide and 32 thick (just thick enough to avoid edge effects when filtering). The hill width is 128 and valley width is 128. It is filtered with a gaussian with kernel of 24. This seed array was then scaled and repeated to yield each desired feature size, for example the .7 mm and 7 mm gratings in Figure 8 and Figure 9.

FIGURE 7. Seed for version-2 textures

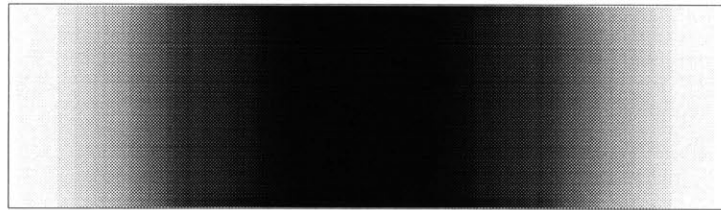

FIGURE 8. Seed scaled and repeated for 2.5 mm grating

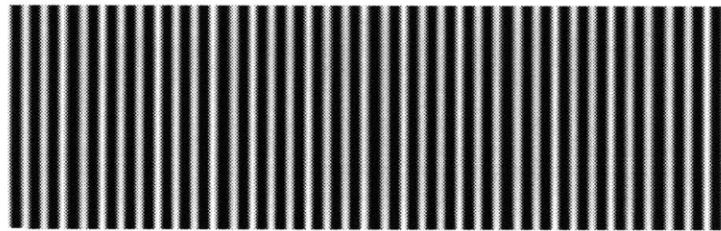

FIGURE 9. Seed scaled and repeated for 5.0 mm grating

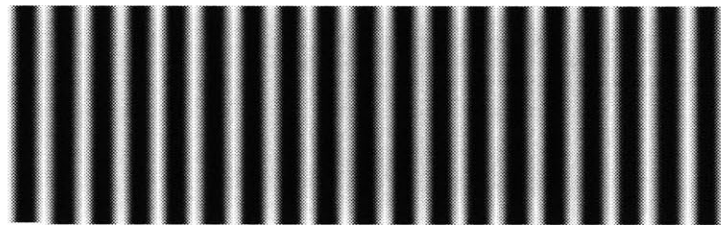

Table 3 summarizes these sets of haptic materials, objects, regimes, and textures.

TABLE 3.

Named	Texture Seed	Force Model	Used in
Version-1 Set	2D height map, 8 bit, processed with gaussian smoothing filter; imagery of gratings, grids and Perlin noise	local gradient of texture height array	pilot tests; Confidence Experiment (Chapter 4)
Version-2 Set	1D slice of smoothed 8-bit grating texture array, sampled to spatially replicate	local gradient of texture height array	Qualitative Roughness, Quantitative Roughness (Chapters 5, 6)
General height-map texture modules	2D height map, 8 bit, processed with gaussian smoothing filter imagery from various synthetic and natural images	local gradient of texture height array	Informal texture library creation

3.5.3 Other Textures from Surface Geometry

I experimented with haptic display of medical imagery (surfaces of bone reconstructed from volume MRI data¹), micrographs of plant cells, $1/f$ fractal noise textures², Gibbs synthetic noise textures created by Rosalind Picard [Picard92], and digitized imagery from Brodatz's [Brodatz66] photographic book of real-world visual textures.

3.6 Artifacts and Limitations of Lateral-force Texture

3.6.1 Quantization of Force Values

The values of force that are felt as a user scans over a Version-1 or Version-2 texture are strongly quantized. The Version-1 texture simulations are based on 8-bit resolution height maps. These height maps are differentiated (in other words, the local slope is computed at each point). The val-

1. by Marc Levoy at University of North Carolina-Chapel Hill

2. imagery courtesy of Davis Heeger and Alex Pentland of the MIT Media Lab

ues that the derivative can take on are very limited. First, with only 256 possible height values, there are a limited set of height differences that can occur. Furthermore, Version-1 textures have a spatial resolution of only about 27 samples/cm. Thus the slopes of the texture features rise quickly from 0 to 256 over a small number of spatial samples, and only a few gradient values are seen. Depending on the size of the texture features and the size of the smoothing filter, this number of values ranges from 5 to 8. The forces the user feels are proportional to these gradient values, so the textures are displayed with only 5 to 8 different levels of force. There are only about 3 bits (8 values) of force.

It is not clear that increasing the number of force levels would substantially change the way these textures feel. The differences in force between these levels is already close to human discrimination ability (see section 5.4.2).

What is important to note is that the force-quantization effect results from the resolution of height values used to represent the texture features and the shape of the features.

Version-2 textures have increased spatial resolution, but have the same 8-bit height resolution as Version-1 textures.

To see whether increasing the number of force values makes a qualitative difference in the way these textures feel, we substituted the height value itself for the gradient of the height value, in an anecdotal test of increased height resolution. The Version-2 texture seed was used in this test; it has about 24 different height (and in this case, force) values in the range 0 to 256 (contrasted with 5 force values it produces using the gradient algorithm). The textures displayed this way did not feel qualitatively different to two experienced users of the system.

3.6.2 Smoothing Filter Issues

The smoothing filter kernel for Version-1 texture patches varied from 1 to 4, depending on the size of the features. This leads to subtle differences in the slope shape of the texture hills and valleys, which is not independent of the feature size. It is an open question whether this systematically affects perception of these textures.

Version-2 textures were all derived from a seed with higher spatial resolution than Version-1 textures. The seed is filtered once with a kernel size of 24 before scaling to different feature sizes, thus the shapes of the feature slopes are the same at all sizes.

3.6.3 Analogy to Real Materials

There is an interesting analogy to the experience of Lederman, et al. in the creation of texture stimuli. Lederman created a set of precisely machined metal block surfaces with a particular geometry (rectangular-wave gratings). In the current work an attempt was made to create a set of precisely specified *simulated* surfaces with *virtual* geometries. In my experiments, as in Lederman's, psychophysical hypotheses about the relationship of psychological percepts to geometric parameters were tested. But it is never easy to create objects to touch that are exactly as we wish them to be. In Lederman's work, electron microscopy of the machined metal blocks revealed artifacts of the machining process, small scale burrs, that had to be taken into account when analyzing human response to the geometry of the blocks [Lederman74]. Similarly, the "machining" operation of digital signal production and filtering creates artifacts in our ideally specified virtual haptic materials.

The next three chapters discuss the results of psychophysical experiments on properties of the Version-1 and Version-2 texture sets. The experiment in Chapter 4 verifies people's confidence that

the Version-1 set are indeed textures. Chapter 5 and Chapter 6 address the factors that contribute to perception of roughness of Version-2 grating textures.

4 Confidence Experiment: Convincing Textured Surfaces

Demonstrating Believability of Simulated Texture

This experiment is designed to determine whether the textured surfaces created with the lateral-force gradient algorithm are convincing: “Can the *Sandpaper* system create surfaces with qualities of texture?” The easiest way to find out is to ask people. In this experiment I presented subjects with a wide variety of stimuli. Subjects rated their confidence as to how convincing the stimuli were as textured surfaces.

The stimuli were chosen to provide substantial variation in textured surface geometry. Two of the tested geometry categories, gratings and grids, were analogous to geometries of real textured surface stimuli used in previous haptics work [Lederman72]. A category of irregular bumpy surfaces was also used. (Previous irregular real-world experimental stimuli have consisted of irregularly spaced dots.) The stimuli spanned a range of simulated hill-and-valley widths, overall feature sizes, and force amplitudes for all the texture types.

Are there boundary values for physical factors that separate regions of convincing from unconvincing textures? This experiment was designed to answer this question. I also hoped to find suggestive data in the texture confidence values to support further probes into the influence of factors such as texture category, feature size, and force amplitude. However, the experiment was not designed to definitively unpack either the physical factors or the percepts that contribute to whether the texture stimuli succeed or fail to be convincing.

The four goals of this investigation can be summarized:

-
1. Verify that our method of creating simulations of textured surfaces leads to objectively believable textured surface simulations.
 2. Analyze factors of texture category, hill width, valley width, feature size, force amplitude, subject, and run as they contribute to high or low confidence ratings of simulated textured surfaces.
 3. Investigate qualitatively, through the subjects' verbal descriptions, the physical and geometric factors that are salient in this kind of haptic simulation.
 4. Understand the role of relative judgements in the description of haptic percepts by examining verbal descriptions of a limited subset of the stimuli. A relative judgement is one in which perception or description of one texture sets an altered context for perception and description of the next one. There may be relative judgements in confidence ratings as well.

Method

4.1 Subjects

Fifteen subjects were paid for participating. They were recruited with flyers and e-mail throughout the MIT community. All were experimentally naive. Ages ranged from 18 to 46 with a mean of 25. There were six male and nine female subjects, fourteen of whom reported being right-handed and one not reported.

4.2 Apparatus

The experimental environment is the Sandpaper system described in Chapter 2. The joystick was disguised by a black box to enhance the flat surface effect and to direct attention away from the appearance of a stick-like probe. (Even with the joystick visible, pilot observations indicated that subjects were thoroughly convinced that there was a simulated *surface* present.) A simple visual

display was presented, showing a black square on a white background; it represented the position of the simulated surface in the workspace and was the same size as the stimuli in the haptic workspace (approximately 3.75" square). A circular cursor tracked the subject's hand motion. There were no visual cues for the simulated surface geometry other than the motion of the cursor

4.2.1 Physical Set-Up:

Subjects were presented with the stimuli in the setup as photographed in Figure 10:

FIGURE 10. Confidence experiment set-up

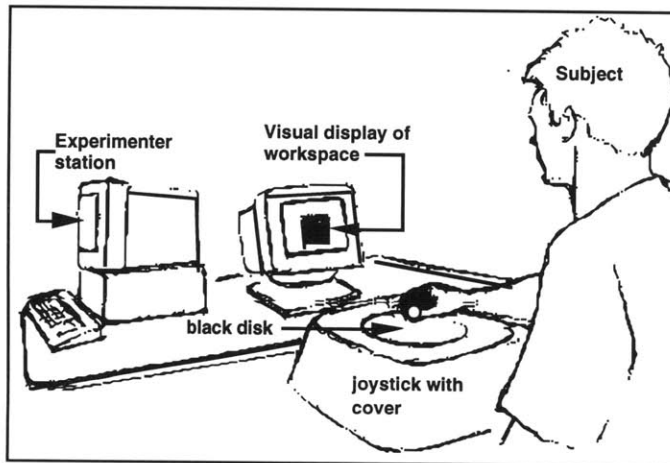
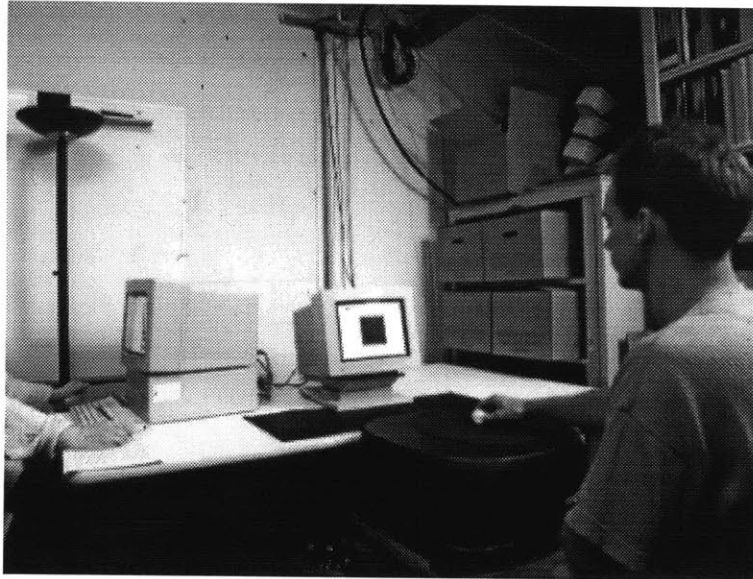

4.2.2 On the haptic neutrality of a ping pong ball

It was hard to decide which kind of handle to put on the joystick for these haptic experiences. During the Chapel Hill, North Carolina research phase, I experimented with substituting a ping pong

ball for the original wood handle of the joystick. I chose a ping pong ball because it was white (to match the visual cursor), a pleasant size for most people to hold in the hand, and very light in weight (to reduce the inherent inertia of the joystick system as much as possible).

For these experiments I wanted to avoid calling attention to the texture of the handle while subjects were attending to the texture of the simulations. A ping pong ball seemed to be haptically neutral, at least with regard to surface texture. (Eggshell was another candidate, but, intuitively, I did not think it would be as good.) A lot of knobs and spheres made from various plastics, wood, porcelain and glass were tried. Each had some overt, characteristic property, such as slipperiness or waxiness that seemed wise to avoid.

The ping pong balls were prepared for rugged handling. A hole was cut in each ball. A threaded metal socket was held in the hole and the ball was filled with polyester craft casting resin for stability. After the resin had set the ball was screwed onto the end of the joystick shaft.¹

Ping pong balls are made of paper which has been waxed (not a plastic as many people assume.) The empirical neutrality may be a result of the fine texture, familiar material, or thermal properties. It would be worth looking further at the concept of neutrality within various haptics applications.

4.3 Stimuli

A total of 102 stimuli were created for this experiment. They included a wide variety of stimuli that were considered “textural” in pilot work. A group of stimuli that were hypothesized to violate reasonable perceptual conditions for textured surfaces were also included to provide a basic check on the believability of these textures.

1. I first tried filling with epoxy resin, but the heat generated discolored the ping pong balls.

The **grating** category is a set of texture patches which simulate wavy gratings that vary in height along only one axis. (They are analogous to the grooved grating set used by Lederman [Lederman72, Lederman74].¹) You may think of these textures as resembling miniature washboards. These vary in spatial frequency, simulated hill width and simulated valley width, and are displayed with varying force amplitude. This latter variable may correspond to the virtual height of the hills.

The gratings' hills and valleys are represented as rectangle waves. These rectangle waves are smoothed using a Gaussian filter. (A rectangle wave without smoothing would be a literal representation of the profile of a grating. However, the smoothing filter removes high frequency artifacts that would occur at the transitions between hills and valleys.

Stimuli used from the grating category represent varying spatial periods, crossed (not fully) by hill and valley width. Spatial period (overall feature size) varies from approximately 2 mm to 20 mm.

The **grid** category is a set of texture patches that simulate two-dimensional regular grids. They are created from checkerboard arrays of hills and valleys, which are Gaussian-filtered for smoothness.

Stimuli used from the grid dataset represent spatial periods corresponding to those in the grating set. This creates a cross between *anisotropic* (grating) and *isotropic* (grid) datasets.² Anisotropy was salient and spontaneously commented upon by subjects in pilot observations.

1. One key difference between these simulated grating textures and the gratings used in Lederman's experiments is that the simulated textures allow the subject to "virtually touch" all points on the gratings, whereas Lederman's gratings' grooves were purposely too deep to allow the subject's fingertip to touch the bottoms of the grooves. Another key difference is that the absolute widths of the simulated set hills and valleys are generally larger than the feature sizes of Lederman's gratings. Spatial periods of Lederman's gratings ranged from .375 mm to 1.25 mm, simulated gratings' periods ranged from 3.6mm to 36 mm, other simulated textures (Perlins) had feature sizes as small as .7mm

2. Note that the subject can move her arm latitudinally (left or right relative to the body) or radially (in and out relative to the body). I use *anisotropic* for a surface that has a different pattern in the radial and latitudinal directions, *isotropic* for a surface that is the same in these two directions.

The **Perlin texture** category is a set of patches characterized as band-limited noise. The features are hills and valleys whose heights and widths are randomly distributed within a specified range. These textures are created by an algorithm invented by Perlin to create effective “random visual terrain” [Perlin 85]. These texture patches are based on a single seed-texture pattern and vary in spatial frequency of the superimposed hill-and-valley variations. These texture patches provide a control for the spatial regularity of the grating and checkerboard textures,

Stimuli used from the Perlin dataset represent feature sizes corresponding to the grating and grid sets. This creates a cross between *regular* and *random* geometry.

Other (Non-Texturals): Elements I hypothesize are outside the realm of texture include a surface with no applied lateral forces (*Smooth*), several with a very large period (one or two large waves, single localized bump and valley), several with high lateral forces alternating closely leading to active jitter (*Noise*), and those which vary the effective viscosity felt by the hand (*Slick* and *Viscous*). I hypothesize that the *Slick* surface may be considered textural by some subjects.

The maximum lateral force-amplitude was a factor varied for stimuli from all categories. To fully cross force variation with feature size would require far too many individual stimuli. Sixteen samples were chosen from the stimuli such that all categories (gratings, grids, Perlins) were represented. Four levels of maximum lateral force-amplitude were presented for each of these sixteen stimuli.

Figure 11 and Figure 12 graphically summarize the stimuli used. Each square represents one of the 102 stimuli patches. Multiple patches in a cell of the figures represent the force-amplitudes chosen for patches with given feature sizes. The printed numbers within squares note the size of the Gaussian filter kernel used to smooth the generator data into fairly smooth hills and valleys (see section 3.5.1).

FIGURE 11. Confidence experiment stimuli chart I

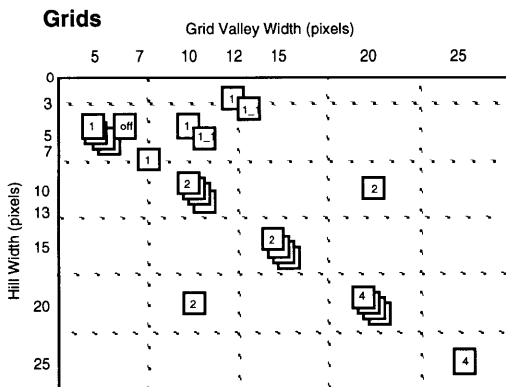
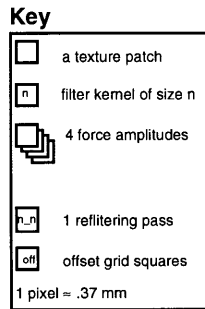
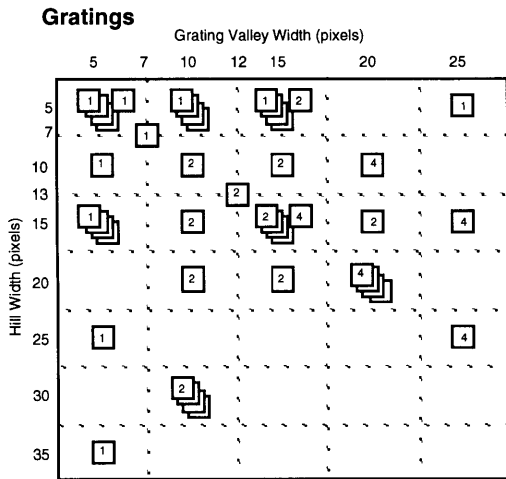
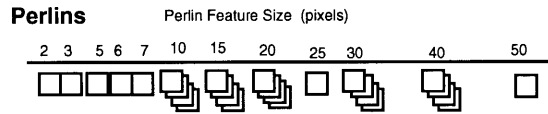

FIGURE 12. Confidence experiment stimuli chart II



Non-texturals Non-texturals (by name)

- Nothing
- Bump
- Slick
- Spring
- Viscous
- Noise20
- Noise35
- Noise50
- 2StripesWeak
- 2StripesStrong

4.4 Procedure:

Note that subjects were asked to rate their confidence that what they felt could be described as a *textured surface* rather than “a texture.”¹

Instructions to subjects:

“We are trying to create simulations of surfaces that you can feel as part of our research in creating ‘virtual worlds’ using computer simulations. You may hold this [point to ball on end of joystick] and move your hand to feel the surface [point to white frame on screen]. This [point to cursor] will show you the position of your hand. I will give you many different surfaces to feel. For each one, I would like you to tell me whether it feels like a surface with some sort of texture attribute that you might describe as rough, bumpy, smooth, and so forth. Please tell me this by giving a “confidence rating”. That is, tell me how sure you are that it is a textured surface, that there is a texture on it. If you are completely sure that it feels like some sort of textured surface, that you would describe it that way, say ‘100%’. If you are completely sure that what you experience is not some sort of textured surface, that you would not describe it as a textured surface, say ‘0%’. For example if you feel something but you would never describe it as a textured surface, give a rating of 0. If you are not sure, give a rating in between that says how likely you would be to describe what you feel as a textured surface. Please give a quick, intuitive judgement. I am asking for a first impression. In fact, I will not give you much time with each surface. Make a quick judgement and we’ll go on to the next one. We will run through the surfaces now to get used to doing this.”

The subjects were instructed to hold the white ball (joystick handle). They were free to choose whether to use a right- or left-hand position and grip. Note that the experimenter showed the subject a version of the flat finger grip briefly, when demonstrating how to move the ball. Common grips included a flat finger grip, a spider grip, and more rarely a flat palmar grip.

1. There are two reasons for using the phrase “textured surface” rather than simply “texture”. First, we were, in fact, interested in whether the stimuli were perceived as surfaces. Second, since we are interested in the kinds of texture that are present on surfaces, this phrasing helps to ground the question for the subjects without offering other verbal examples of textures which could be a source of bias.

The subjects were asked to feel each stimulus and give a confidence rating quickly, although there was no explicit time limit. (See “instructions to subjects” below.) Data from subjects who failed to complete two runs within 60 minutes were dropped from the analysis.

Subjects were then presented with a practice set of 36 stimuli, which included representative gratings, grids, Perlins, and all non-texturals. They then rated two full sets of all stimuli prepared in pre-randomized orders, with a five-minute break between sets.

After the confidence rating sets, each subject was asked to describe “what they feel like” for approximately 20 stimuli. (This procedure was truncated if the total time for the session reached 60 minutes.) If the truncation happened during the confidence ratings, the subject data were discarded.

The purpose of the verbal descriptions was to elicit comments about the *type* of texture percept that was salient for each stimulus, for example, roughness or bumpiness. These comments were also a window onto the perceptual nature of stimuli that are not considered textural. I wondered if subjects would describe surfaces, materials, or other types of sensations when presented with those stimuli.

I also hoped to compare exploratory strategies (from hand motion observations) with percepts reported by the subjects’ in their descriptions. Recall that Lederman and Klatzky report highly stereotypical hand motions (*exploratory procedures*) associated with recovery of particular haptic attributes of objects. I expected that when subjects were attending to texture while feeling a patch, they would use the “lateral motion” exploratory procedure. When subjects perceived larger, individually embossed bumps, then I expected the “contour following” exploratory procedure.

Some of the subjects were asked “If the textured surfaces feel like they have a location in space, where are they?”

4.5 Results and Discussion:

Analysis of the mean confidence ratings provides insight into the believability of the simulation of textured surfaces and the influence of geometric factors. Quantitative analysis and analysis of subjects' rating scales gives us insight into similarities and differences between individuals. Qualitative review of auxiliary data such as subjects' verbal descriptions of the stimuli suggests questions about salience of haptic features, as well as descriptive strategies, themselves.

4.5.1 High Overall Confidence

The main result is that analysis of subjects' confidence ratings yields high overall confidence that our simulations could be described as textured surfaces. 49% of the subjects' individual ratings are 80 and above, 27% of individual ratings are 100. Some of the stimuli are very highly rated; 20% of stimuli have mean ratings above 80.

In contrast, non-texturals are low rated. The confidence raw score of non-texturals *excluding* the noise textures is Mean = 26 (+ or - 14). The confidence raw score of non-texturals *including* noise is Mean = 38 (+ or - 10). There is also a trend toward low mean confidence for texture stimuli that have both very low force-amplitude and very large spatial feature size.

4.5.2 Factors contributing to Confidence

A multiple regression analysis of mean texture confidence shows whether geometric and force factors have predictive value for textured surface confidence. A regression analysis of mean confidence rating was performed on four factors: hill width, valley width, feature size (hill width + valley width), and force amplitude.

Hill width is the width of the upper part of a repeating texture element. For a grating, it is the width of the stripe. For a grid, it is the width of the square "plateau". Valley width is the width of the

lower part of a repeating texture element. For the irregular Perlin textures, hill and valley widths are averages of the high and low regions over the entire patch.

Feature size is the spatial period of a repeating pattern in the stimulus. For grid and grating stimuli, the size is the sum of hill and valley width. For Perlin textures, it is the spatial period of the underlying noise grid. It is the same as the visually perceived feature size.

Non-textural stimuli have been assigned feature size values. Those non-textural stimuli that have the character of surfaces (such as `slick`) but no apparent features are assigned a feature size of zero. The stimuli with extremely large bumps have large feature sizes; they are outliers in the feature size distribution (`2WideStripes`, `Bump`, and `Spring`). `2WideStripes` has a feature size of 85. `Bump` and `Spring` have a feature size of 256 because they are interpreted as a single bump and a single valley across the entire width of the stimulus patch. Noise stimuli are assigned a feature size of zero, on the grounds that their jitter-inducing transitions between very high and low force occur closer together than the feature sizes of any of the texture stimuli (another plausible value would be “1”).

`MaxGradient` (Maximum Gradient) is a variable proportional to the maximum lateral force felt by the subject as she moves across the stimulus¹. This is named after the algorithm producing the lateral forces from the texture height maps, the lateral-force gradient algorithm. The maximum force from any stimulus is proportional to the maximum height gradient that occurs in its height array (see section 3.5.1).

There is no significant accounting for texture confidence from hill width or valley width. `MaxGradient` (force amplitude) shows a small increasing trend with respect to texture confidence. Feature

1. This is one of several candidate definitions for the force amplitude felt by the user when moving over a stimulus. It would be interesting to analyze the relationship of Maximum Gradient to some of the other candidates, in particular to the average lateral force felt if moving across a straight line in the middle of the stimulus patch.

size appears to account for a small inverse trend in texture confidence ratings. However, when the non-textural stimuli, some of which have extremely large feature sizes, are removed from the analysis, only force amplitude remains as a significant factor. MaxGradient (force amplitude) shows a small increasing trend with respect to texture confidence with a t-ratio of 4.03 and R-squared of 23%.

Figure 13 through Figure 15 show scatterplots of mean texture confidences against MaxGradient (force amplitude). Figure 13 shows grating textures, Figure 14 shows Perlin textures, and Figure 15 shows non-texturals. The most striking effect is that very low force amplitude, particularly in combination with large feature size, is associated with low confidence.

In order to further understand the regions of influence of force amplitude, we divide the dataset into high-confidence and low-confidence producing stimuli. We define high-confidence as those stimuli with mean confidence scores greater or equal to the mean of all confidence scores (65); low-confidence stimuli as those with mean confidence scores lower than that. High-confidence stimuli are marked in black and low-confidence stimuli in grey.

FIGURE 13. Mean confidence for gratings vs. maximum force amplitude

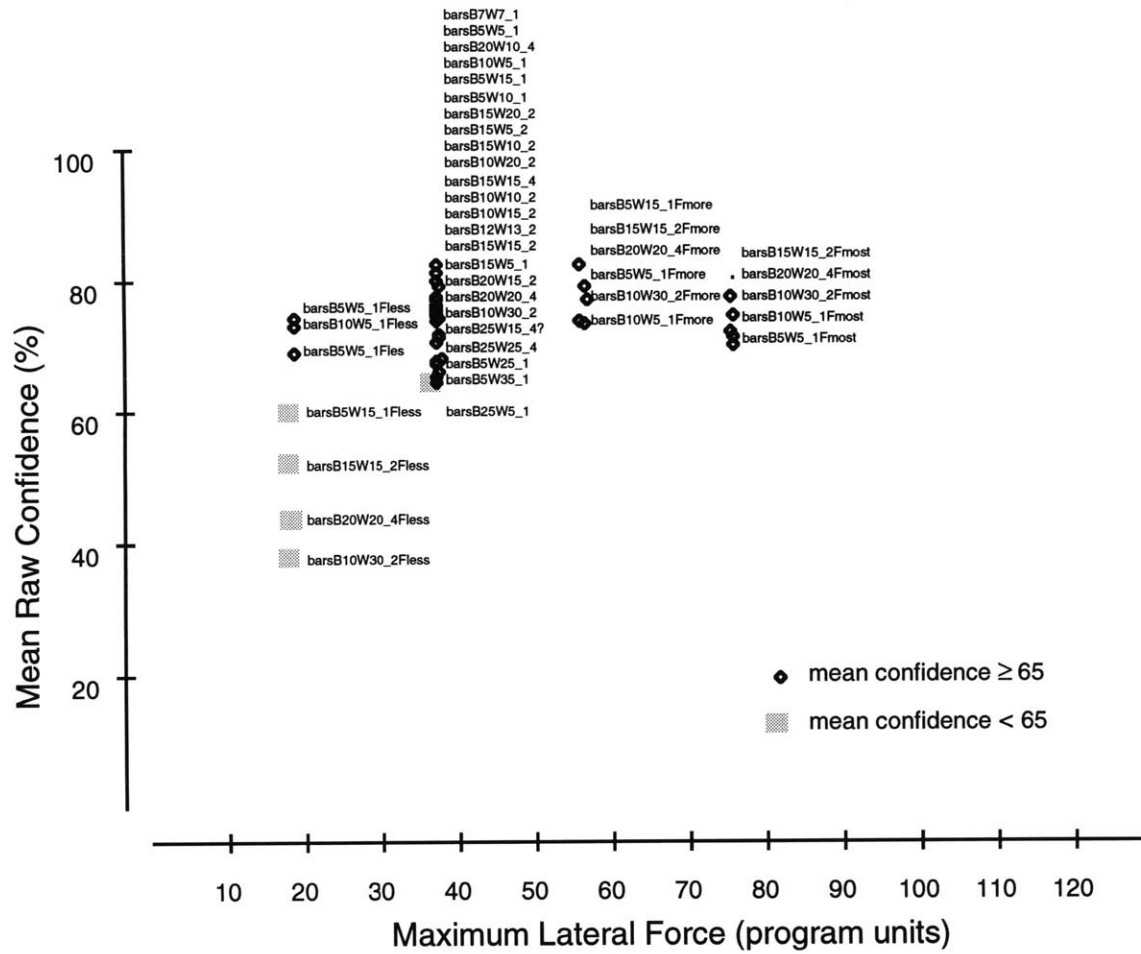

FIGURE 14. Mean confidence for Perlins vs. maximum force amplitude

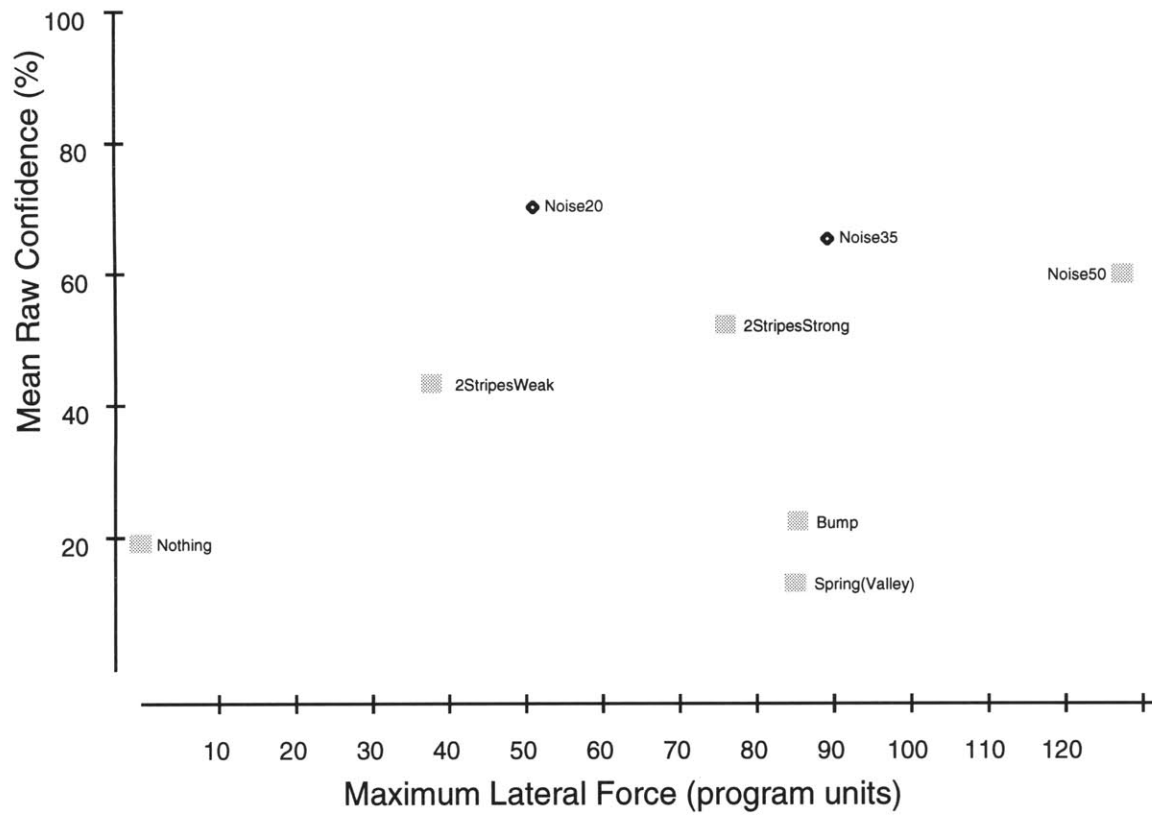
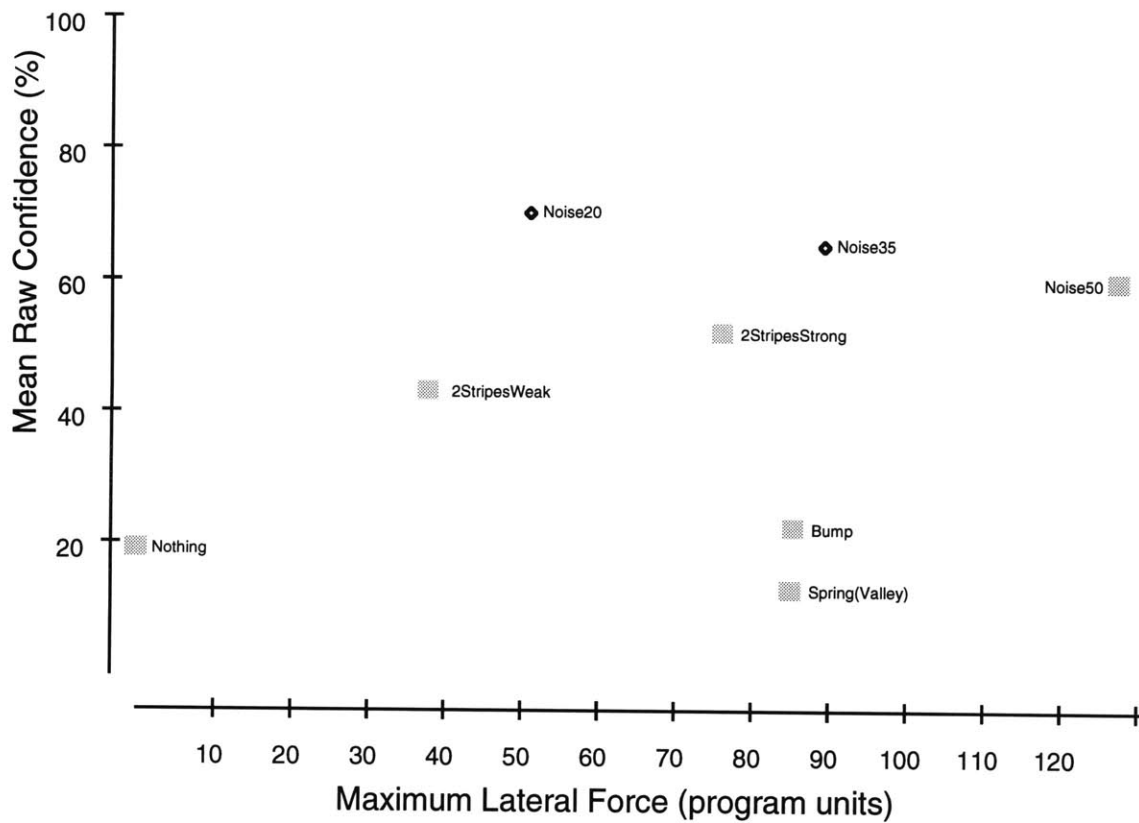

FIGURE 15. Mean confidence for non-texturals vs. maximum force amplitude



Low maximum force amplitude (which is analogous to a texture feeling *shallow*), in combination with large feature size, is associated with low texture confidence for all types of stimuli.

Within the high-confidence set there is very little effect of force amplitude on confidence ratings.

Examining low-confidence textures in the grating and Perlin sets, for a given maximum force, there is a strong correlation between feature size and confidence rating. The low-confidence stimuli predominantly have feature sizes larger than 20.

One interpretation of the relationship of confidence rating and feature size for low-confidence stimuli is as an artifact of the definition we have adopted for force amplitude. We define force amplitude as the maximum force amplitude that the subject's hand can encounter when moving over the stimulus. For very large feature sizes, this maximum amplitude may be encountered only in steep parts of the "slopes" between hills and valleys. If one assumes a constant speed of the hand across a stimulus, the time spent feeling the maximum force amplitude for feature size 30 would be about one third that felt across a stimulus of feature size 10. Similarly, the number of times that the greatest force transition would occur would also be one third. In this case, the sensitivity to force may be better modeled by the average force felt by the subject, or the density of force transitions, or another model. Investigation of these possibilities would be most fruitful when the hand trajectories are recorded so that the time variation of force on the users' hand is known.

Non-texturals: Table 4 shows the confidence values for the non-textural stimuli (except noise stimuli, which are treated separately).

TABLE 4. Non-textural stimuli confidences

Stimulus	Mean Confidence (%)	+/- 1SD
Slick	11	18
Spring (Valley)	13	19
Nothing	19	30
Bump	22	28
Viscous	23	23
2StripesWeak	43	36
2StripesStrong	52	37

Noise Stimuli: Among the non-texturals, the noise textures have middling confidence values of 70 (+/- 32), 65 (+/- 38), and 59 (+/- 39). respectively for `Noise20`, `Noise35`, and `Noise50`. These mean confidences are higher than for the other non-texturals. The noise stimuli are not easily amenable to a definition of feature size, although the underlying seed may be considered to have a feature size of 1. Other stimuli in the same confidence range include weak force, large feature size stimuli such as `Perlin30less`, and `Perlin50`. Although subjects called attention to the striking, qualitative jitter of the Noise stimuli, in verbal descriptions it appears that they are interpreted as textured surfaces with more confidence than we would expect. Some of the subjects mentioned texture under something jittery or moving “ball bearings” of identifiable size.

Effect of Run: the mean within-subject inter-run correlation¹ for raw confidence scores is 0.63 (which corresponds to 39% of inter-run variation accounted for by run). Thus we observe that although there is a substantial run-to-run agreement in subjects’ confidence values, there is also

1. Pearson Product Moment

enough variability to reinforce our impression that texture confidence has inherently high variability in a context-free haptic simulation presentation.

4.5.3 Intersubject Rating Patterns

It is illuminating to consider ways to compare subjects, in order to understand regularities and differences. Figure 16 consists of histograms of the raw confidence ratings given by each subject. (Recall that there are 102 stimuli in each of two runs, so the total number of counts for each histogram is 204). I have arranged them according to my intuitive visual matching for similar shape.

Looking at the subjects individually, we can classify two clusters of histogram patterns, and three more individualistic patterns.

In the leftmost column of Figure 16, S136, S139, S140, and S135 form a cluster of “bimodal-clipped” responders of which S140 may be seen as a prototype. This cluster is characterized by high mean confidence, a large number of responses at the 100% confidence level, a cluster of responses at the 0% level, and very few intermediate values.

S167, S134, S165, S132, S164, S131, S166, and S138 form a cluster of “intermediate value users.”

In the rightmost column of Figure 16, S133, S137, and S162 may be characterized informally as “skeptical” in their use of confidence ratings. They have low overall raw means and, in the case of S137 and S133, have distributions skewed toward low ratings in contrast to the other subjects. S162’s distribution is approximately normal around a raw confidence level of 50%.

Interestingly, the verbal descriptions of stimuli from S137 and S133 do not show significant differences in their descriptive language or use of metaphors compared to those of other subjects.

In the sections 4.5.1 through 4.5.3 above, we show that indeed, texture confidence is high for many of the simulated textures we created, verifying that we have created objectively believable simulations.

FIGURE 16. Histograms of subject confidence ratings

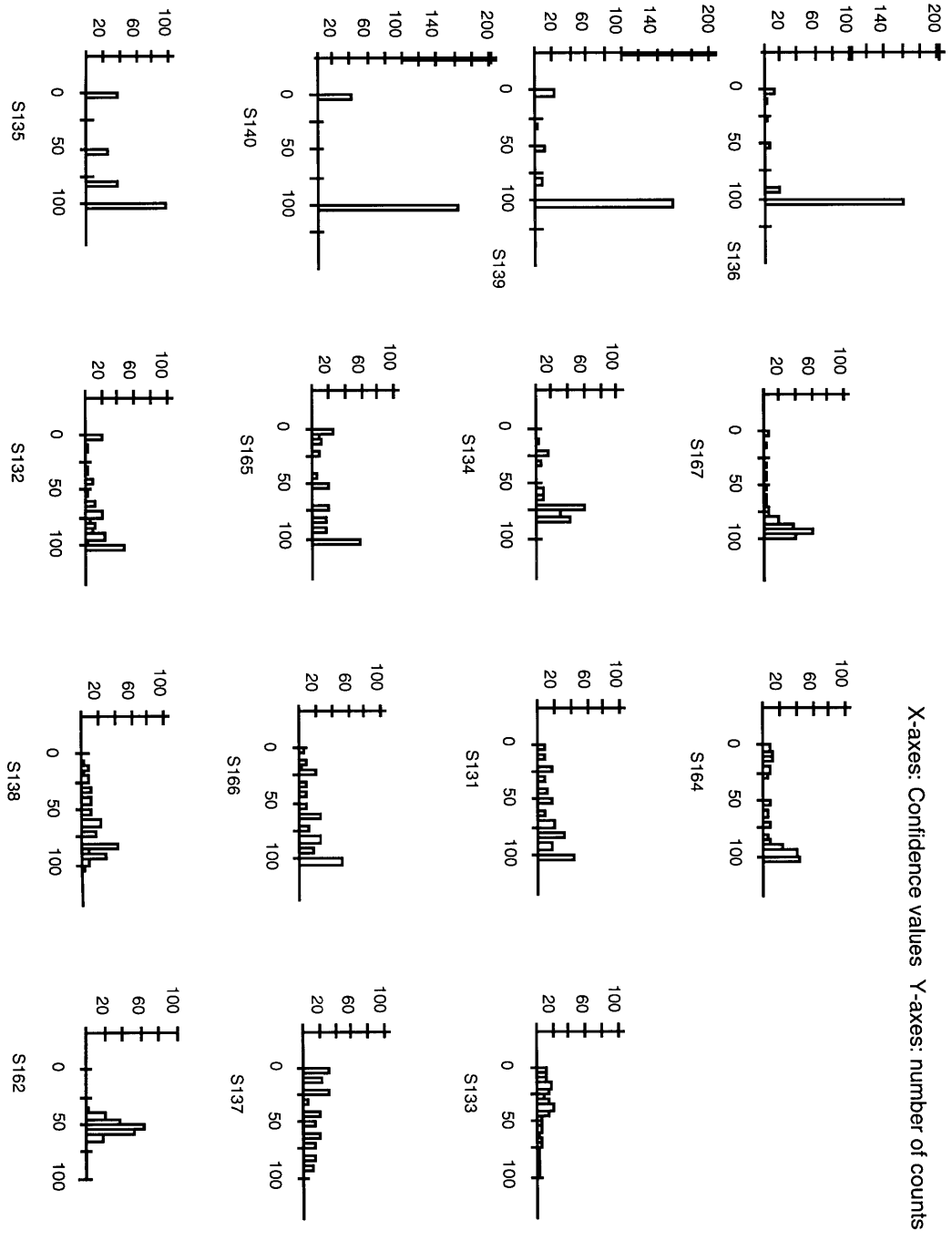

4.5.4 Texture Descriptions

Each subject described 24 to 35 stimuli. The first 24 of these were the same for all subjects. A few subjects had time to describe additional stimuli. After 20 stimuli, the set was repeated starting at stimulus #3 (perlin5) in order to obtain a second description by each subject of several of the stimuli. To get a flavor of some of the descriptive language, Table 5 contains a transcript of subjects' descriptions of three of the stimuli.

Table 5 contains the first three stimuli that all subjects were asked to describe in words. They were told "briefly tell me about how this feels, in words" or "give a short description in words of how this feels to you." The notation P: means that the experimenter, after hearing a description, *prompted* the subject to make a comment about feature size by saying "can you tell me about the size of the [bumps or ridges or...]?" or "what can you say about the size of [...]?" When a subject mentions size it could be a result of bias from a prompt earlier in the session.

TABLE 5.

Subject #	Stimulus: grating, feature size 40, force level "most" (B20W20_4Fmost)	Stimulus: grating, feature size 10, force level "more" (barsB5W5_1Fmore)	Stimulus: perlin, feature size 5
S135	Changing gears on a lawnmower	surface, hi grooves one way to the other	uniformly grainy
S134	sawtooth	heavy grade sandpaper	fine grit sandpaper
S133	bumpy	like ice cubes that have water then freeze; grainy plastic	almost smooth, bumps so small you hardly notice
S132	column of ridges	columns of very narrowly spaced ridges	randomly places little lined(?) bumps
S131	deep undulation, 1/4" in between	ridgy very small ridges	goosebumpy
S136	corrugated material	fine corrugation bumps, P: 1/8"?	very fine gravel feel both vertical and horizontal
S137	jerky	medium surface	vague; low surface
S138	asphalt, very rough, slightly rough	medium rough	fairly smooth like an eggshell
S139	vertically corrugated surface P: wide wale	vertically corrugated much finer: P: ribbing like on old garden hose	cross hatching on a machine tool
S140	slightly bumpy	more uniformly bumpy P: pebbles, no smaller, not sand	more sandy
S162	bumpy	rough and slick	fine bumps
S164	jagged	jagged	bumpy

Subject #	Stimulus: grating, feature size 40, force level “most” (B20W20_4Fmost)	Stimulus: grating, feature size 10, force level “more” (barsB5W5_1Fmore)	Stimulus: perlin, feature size 5
S165	craters	grating - really small holes	rough surface - sand paper not big holes
S166	rough	harsh	somewhat smooth
S167	not smooth, very jagged, very heavy on wheels going over peak and falling off	much finer grain; steel ball with high moment stays and then slides	scratching over steel cloth

Descriptive terminology: The descriptive terminology in the table was volunteered by the subjects, except for influence from experimenter prompts about size. As you can see, descriptive terminology comes in several styles. Some of the descriptions are in terms of texture concepts or analogies to the real world that I predicted: sandpaper, grating, graininess, bumpiness. Gratings were often described as corrugated or ridged. There are some descriptions in terms of physical objects such as pebbles and ice cubes, or mechanical systems such as a gearshift. The variety of responses is striking. It is not surprising though, that without either a visual or a purposive context, there are many ways to interpret and to describe a region of haptic sensation.

Verbal descriptions parallel all levels of the material/perceptual representation framework, with descriptions of physical and perceptual parameters, and comparisons to particular real objects.

Relative Descriptions: The design of the quantitative part of this experiment gives us no access to the question of whether confidence ratings are absolute or relative. Interestingly, we can see substantial evidence of relative descriptions when subjects are asked to give short verbal descriptions

of the stimuli. From a total of 428 verbal descriptions of stimuli, 51 (12%) of the descriptions used relative language such as “same as”, “more”, “less”, “in between --- and ---”, and -er words in reference to the most recent or the two most recent stimuli. (Also one description mentioned the “first” stimulus and one mentioned a stimulus farther away in the presented order.) Perhaps one stimulus primes a perception or description of a subsequent stimulus. More suggestive in the description data are runs of one type of description, for example “bumps; big bumps; small bumps” followed by a shift in descriptive terminology. In particular, there are instances of runs of descriptive terminology that do not recur when the same stimuli are presented much later. This suggests that the use of a particular descriptive terminology or perhaps underlying concept may bias the subject to describe haptic stimuli in the same terms as long as it can be kept appropriate. However, the same stimuli presented in another context or later may not evoke use of that particular terminology. It should be noted that this run-then-shift-of-terminology occurs in the descriptive data from this experiment; it is not possible to usefully correlate it with quantitative confidences or other perceptual data. Also, this evidence does not yet allow us to discuss whether *perception* of haptic aspects of the stimuli is altered by relative order of presentation, only *description*. This very rich area should be explored further in case studies and other experimental designs.

4.5.5 Hand movements

Hand motions were recorded on videotapes but have not been analyzed at this time. According to informal records, motions were predominantly quick lateral or circular motions (i.e. the Lateral-Motion exploratory procedure). An important question to be asked in video analysis is whether subjects are seen to use contour following or other identifiable strategies. Some of the verbal descriptions are of surface textures, while others are of feature shapes and spacing; the hand motions should be analyzed to see whether the former are more closely associated with lateral motion and the latter with contour following.

Conclusions:

1. 20% of stimuli have mean confidence ratings over 80%. A large number of stimuli (simulated textures) resulted in very high confidence ratings from subjects. Furthermore, a very high fraction of individual subject ratings were at 100%.

Specifically, grids and gratings are all fairly highly rated, except for some low-force stimuli. Perlin textures with high forces and small periods are highly rated.

2. Stimuli hypothesized to be non-textural have very low confidence ratings, with the exception of the noise stimuli. Of the non-texturals, only the noise stimuli is rated near the mean of all stimuli. Of the rest, `2StripesStrong` and `2StripesWeak` have the highest ratings; they are arguably closer to being textures by virtue of having surface undulation, albeit very large in size.

For grid and grating stimuli, confidence levels are low if the maximum force amplitude is less than 30 units (about 56 g (2 oz.)) *and* the spatial period is greater than 25 (about 9.25 mm). For Perlin stimuli, ratings are low for a much larger range of maximum force amplitude and for smaller feature sizes (down to 15 units (5.5 mm)). However, other models of the forces actually felt by the user (such as those discussed in section 4.5.2) may better represent the relationship between Perlins and the regular textures, and reduce this apparent contrast.

Within low-confidence stimuli, there is a trend toward increasing texture confidence with decreasing feature size.

We conclude that force amplitude and possibly feature size are salient haptic features for confidence.

We can examine this idea in subsequent experiments with stimuli in the high-confidence region, using better tuned probes than the general, yet somewhat opaque, “confidence rating”.

When compared with real-world textures, the spatial periods of the stimuli in this study start at the upper range of “textural” sizes (for example, it is controversial as to whether people are comfortable with the notion of a *rough* texture if it is composed of features larger than 2.5 mm). Some of the feature sizes in this experiment are considerably larger. Thus we have extended the definition of *texture* (within a simulation environment) to features larger than in the real world. In subsequent experiments we also explore smaller feature sizes comparable to those of real-world textures.

3. The descriptive language from subjects is rich with spatial descriptions, surface texture descriptions, feature descriptions, size description and real-world metaphors. These occur at all levels of the material/perceptual representation framework (physically-based descriptions, perceptually-based descriptions, and representative-based descriptions.)

In the next two chapters, I report on an investigation of roughness, a haptic percept of textures. I used simulated grating textures that are closely related to those in this chapter, and whose sizes and force amplitudes overlap the region of high-confidence gratings from this chapter.

5 *Quantitative Roughness*

5.1 Scaling of roughness using magnitude estimation

This experiment investigates the factors that contribute to perceived roughness of simulated grating textures. The *roughness* aspect of texture is studied here because

- roughness is a useful descriptive term for textured surfaces (as seen in Chapter 4, also in e.g. machine shop specifications [GEScale],)
- roughness is the most well-studied aspect of real textured surfaces.

Originally, this experiment was designed to parallel those performed by Lederman [Lederman72] in which psychophysical factors for roughness perception were identified. Those experiments investigated perceived roughness of machined metal gratings. Factors affecting perception of roughness were identified as downward finger force and a spatial parameter, valley width (width of low portion of grating).

I hypothesize that perception of roughness in an environment of simulated grating surfaces is also dependent on dynamic and spatial factors, in this case force amplitude and spatial period. The rationale for this comes from analogies between the model in Chapter 2 for textures felt with the joystick and the perception of roughness of real textures.

In Chapter 2, the act of touching a textured surface with a joystick is modeled as touching a corrugated surface with a stylus held in the hand. In that model, the real-world downward force of gravity creates lateral forces felt by the user. If the user were to *push* down on the stylus, the lateral force components felt at the hand would increase. This would be analogous to differing amounts of finger force used in naturalistic haptic exploration. In [Lederman72], increasing downward finger force was found to increase perceived roughness. Thus I hypothesize that force amplitude is a factor in perceived roughness of simulated textures.

The stylus model involves one point of contact between the textured surface and the hand's probe, that is, the tip of the stylus. In the real world, a person uses the fingertip as a complex, direct probe onto a surface. Spatial information must be processed quite differently in these two situations. I hypothesized that information about the temporal periodicity of the texture features, available to the hand touching the joystick, might be an important cue for recovering spatial information about texture features, and thus that spatial period of a grating would be a factor in roughness perception. (Compare real world textures, where valley width, not spatial period, of a regular grating is a factor in roughness perception.) In addition, pilot studies in which subjects ordered a small set of simulated gratings by roughness showed a trend toward associating perceived roughness with increasing spatial period. (In retrospect, the importance of force amplitude was not as well understood and may not have been well controlled in those studies.)

5.1.1 Summary of Results

Over the range of stimuli chosen for this experiment, roughness was found to be a scalable percept. Quantitative perceived roughness is accounted for almost completely by force-amplitude variation of the stimuli. There was no significant variation in perceived roughness due to spatial period.

It is noteworthy that subjects maintained such a robust perceptual scale of roughness, that was apparently dependent only upon force amplitude. This result is puzzling. One reason is related to the qualitative-roughness classes seen in Chapter 6: that there are classes of simulated gratings that appear to be characterized by a combination of force-amplitude and spatial-period factors. Anecdotal comments of the subjects in the current experiment reinforce the notion that there are "different kinds of roughness" at different size scales, that there are qualitatively different classes of textures among the stimuli, and that subjects do indeed take note of geometric features.

5.2 Method

This experiment used a magnitude-estimation paradigm to elucidate perceived roughness of *grating* textures. A within-subject design was used, with factors of spatial period, force amplitude, and repetitions. The spatial-period and force-amplitude factors were not completely crossed.

5.2.1 Subjects

Fifteen subjects were paid with ice cream certificates for participating. They were recruited with flyers and e-mail through the MIT community. All were experimentally naive. Ages ranged from 18 to 53 with mean 33 years. There were 7 male and 8 female subjects, 12 of whom reported being right-handed and 3 left-handed.

5.2.2 Stimuli

The 30 texture stimuli sample 28 force amplitudes and 9 spatial periods. The spatial periods (0.7 mm to 10.0 mm) span those used in the Texture Confidence experiment (Chapter 4). The upper range of these sizes is known to generate high texture confidence; in that experiment, mean confidence rating of stimuli with period 7.4 mm was 71%. They also include spatial periods smaller than those used in the Texture Confidence experiment. This became possible because of technical improvements in the joystick system subsequent to the Texture Confidence experiment. Evidence from the literature [Lederman72] and casual testing indicate that these smaller featured surfaces should be good candidates for having perceivable roughness, and, in fact, are closer to the realm of real-world perceived roughnesses.

The amplitude levels chosen for this experiment result from an observation, in pilot studies, that subjects put several values of absolute force amplitude together into equivalence classes that we called force-levels. However, forces are reported for the current experiment in terms of absolute

force-amplitude (28 values) rather than the original “force-levels”. It remains as puzzling why the pilot studies, in which volunteers *adjusted* forces until a set of stimuli with differing spatial periods felt “the same” (in intensity, magnitude, or force), yielded certain equivalence classes of force amplitudes, while results of the current experiment reveal subjects’ striking sensitivity to differences in force amplitude when attending to roughness estimation.

Figure 17 shows a visual representation of a horizontal slice of the seed grating stimulus. It is a wave represented by a height map array of width 256; first a square wave with period 256 is created and, then, the square wave is smoothed with a Gaussian filter of kernel size 24. This creates a smooth wave. The stimuli in the experiment consist of this seed repeated and sampled so that it creates waves of the desired spatial periods from 0.7 mm to 10.0 mm.

Table 6 shows the force amplitudes and spatial periods of the stimuli.

FIGURE 17. Grating texture seed for roughness estimation, black is hill, white is valley

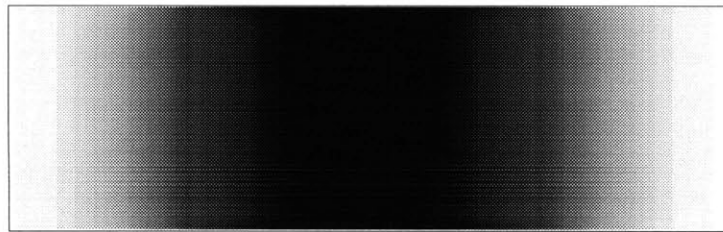

TABLE 6.

spatial period (mm)	amplitude (program units)	Command amplitude (joystick units)	physical force g (oz.)	spatial period (mm)	amplitude (program units)	Command amplitude (joystick units)	physical force g (oz.)
7	17	68	33 (1.2)	25 con't	85	340	167(6.0)
	41	164	81 (2.9)		97	388	191 (6.8)
9	9	36	18 (0.6)		159	636	313 (11.2)
	16	64	32 (1.1)	37	36	144	71 (2.5)
	21	84	41 (1.5)		90	360	177 (6.3)
	42	168	83 (3.0)	50	42	168	83 (3.0)
	52	208	102 (3.7)		105	420	207 (7.4)
	172	688	339 (12.1)	75	44	176	87 (3.1)
12	20	80	39 (1.4)		109	436	214 (7.7)
	50	200	99 (3.5)	100	21	84	41 (1.9)
18	26	104	51 (1.8)		51	204	101 (3.6)
	71	284	140 (5.0)		64	256	126 (4.5)
25	14	56	27 1.0)		120	480	236 (8.4)
	24	96	47 (1.7)		137	548	270 (9.6)
	35	140	69 (2.5)		194	776	382 (13.6)

5.2.3 Procedure

The subjects were presented with these written instructions:

What To Do

We are trying to create simulations of textured surfaces that you can feel as part of our research in creating “virtual worlds” using computer simulations.

You will be given some surfaces to feel. You may move your hand to feel the each [sic] surface. I will give you many different surfaces to feel, and you will rate them according to their roughness.

First you will get the chance to feel many of the textured surfaces so you can get an idea of the feel of least rough and most rough surfaces. The study director will tell you each time a new surface is ready for you to feel.

Then The [sic] study director will ask you to rate each surface’s roughness. Pick a number that best matches the roughness of the surface you feel, using smaller numbers for less roughness and larger numbers for more roughness. You may use whole numbers, decimals or fractions. You cannot use zero or negative numbers. The study director will tell you each time a surface is ready. Say your rating out loud.

The study director will give you a chance to practice giving your numbers that best match the roughness of the surfaces.

Please give a quick, intuitive judgement. We are interested in your first impression of the roughness of each surface. In fact, we will not give you much time with each surface. Make a quick judgement for each surface and we’ll go on to the next one.

Subjects read the instructions, were seated at the apparatus, and shown the joystick handle. After they completed a practice run they were able to ask questions. They then completed three more runs. Stimuli were presented in random order.

Subjects sat in front of the joystick and monitor screen, as in the Texture Confidence experiment, the joystick was attached to a black disk to hide the apparatus. In both the visual and haptic workspaces, stimuli were squares with sides of about 9.5 cm (3.75 in.). The experimenter sat on the left side of the setup while tabulating the verbal ratings and triggering the presentation of the stimuli. This setup is similar to that of the Texture Confidence experiment, although it took place in another cubicle of the same laboratory.

Subjects moved their hands freely within the joystick workspace to feel each texture stimulus.

5.3 Results

Roughness estimates were averaged over all runs and subjects for each stimulus. Roughness estimates were examined against spatial period and force amplitude (Figure 18). Over the wide range of spatial periods of these stimuli, roughness appears to be a percept closely related to the physical factor of force amplitude felt by the user. This appears to be a scalable percept over the range tested.

5.3.1 Roughness Estimate and Maximum Force Amplitude

Regression analysis indicates that force amplitude accounts for over 96% of the variation in roughness estimates.

FIGURE 18. Magnitude estimates vs. force amplitude

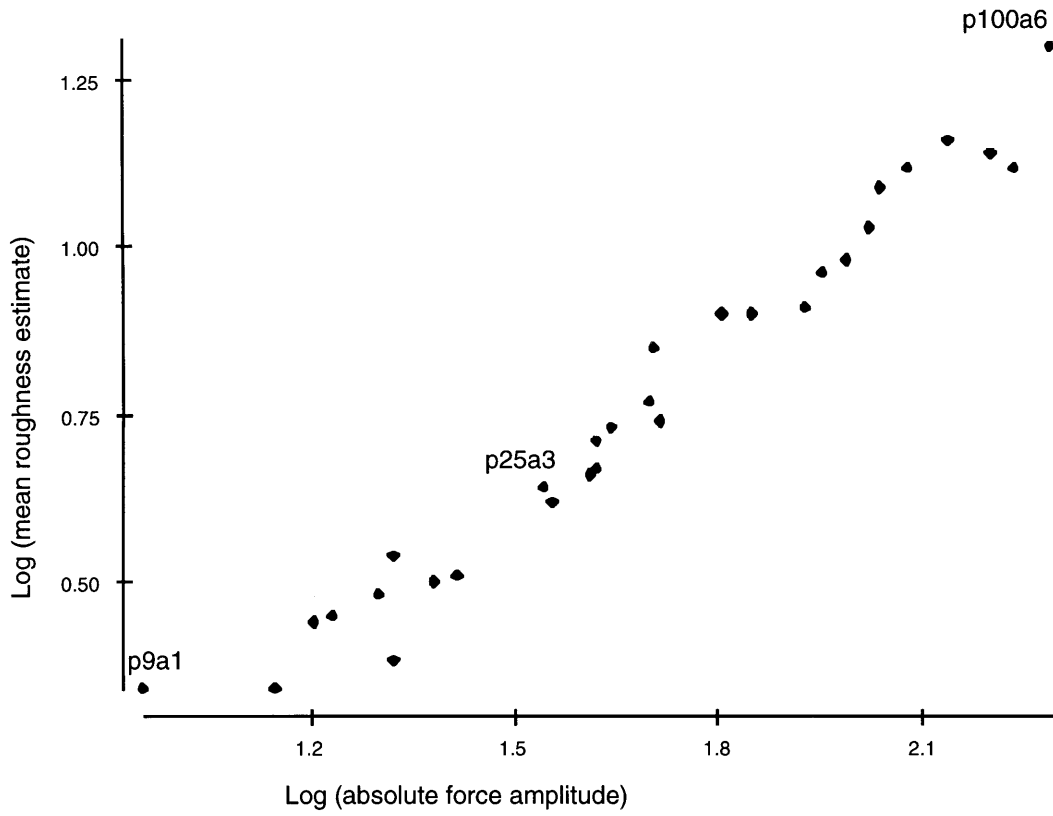

FIGURE 19. Regression of roughness on force amplitude

Dependent variable is: mean rough
 No Selector
 R squared = 96.6% R squared (adjusted) = 96.4%
 s = 0.0519 with 30 - 2 = 28 degrees of freedom

Source	Sum of Squares	df	Mean Square	F-ratio
Regression	2.12719	1	2.12719	789
Residual	0.075531	28	0.002698	

Variable	Coefficient	s.e. of Coeff	t-ratio	prob
Constant	-0.513365	0.0465	-11.0	≤ 0.0001
log amp	0.759593	0.0270	28.1	≤ 0.0001

Thus, we can obtain a predictor equation:

$$\log R = 0.76 \log F - 0.51 \quad (\text{EQ 1})$$

R is perceived roughness, F is maximum lateral-force amplitude for a texture patch. This says that for a doubling of force, there is a 1.3-fold increase in perceived roughness.

We can compare with real-world roughness estimates. The slope of the psychophysical function for dependence of roughness estimates on downward fingertip force (real metal gratings, fingertip forces 1 to 25 oz., grating periods from 0.4 to 1.25 mm), reconstructed from data in Lederman's early experiments [Lederman72] is 0.25.

5.3.2 Roughness Estimate and Spatial Period

The relationship between roughness estimate and spatial period is not significant, when force amplitude is taken into account. Figure 20 is a multiple regression on two predictor variables, log

amplitude and log period. The relationship between period and roughness estimate is not significant.

FIGURE 20. Multiple regression of roughness estimate on amplitude (amp) and period (per)

Dependent variable is: mean rough
 No Selector
 R squared = •% R squared (adjusted) = •%
 s = 0.1180 with 30 - 2 = 28 degrees of freedom

Source	Sum of Squares	df	Mean Square	F-ratio
Regression	19.4153	2	9.70766	697
Residual	0.390085	28	0.013932	

Variable	Coefficient	s.e. of Coeff	t-ratio	prob
log amp	0.514422	0.0489	10.5	≤0.0001
log per	-0.056435	0.0568	-0.993	0.3293

5.3.3 Individual Subjects

Individual subject data are summarized through roughness estimate vs. log absolute force amplitude plots in Figure 21. The roughness estimates plotted in each panel are means for each stimulus over four runs for each subject.

These data are highly consistent qualitatively. That is, all subjects show a roughness percept that can be accounted for by a linear model dependent only on force amplitude. Furthermore, 14 of the 15 subjects' psychophysical function coefficients for roughness are highly consistent (the exception is S54 with a steeper slope)

FIGURE 21. Subjects' mean roughness vs. absolute amplitude (mean of 4 runs)

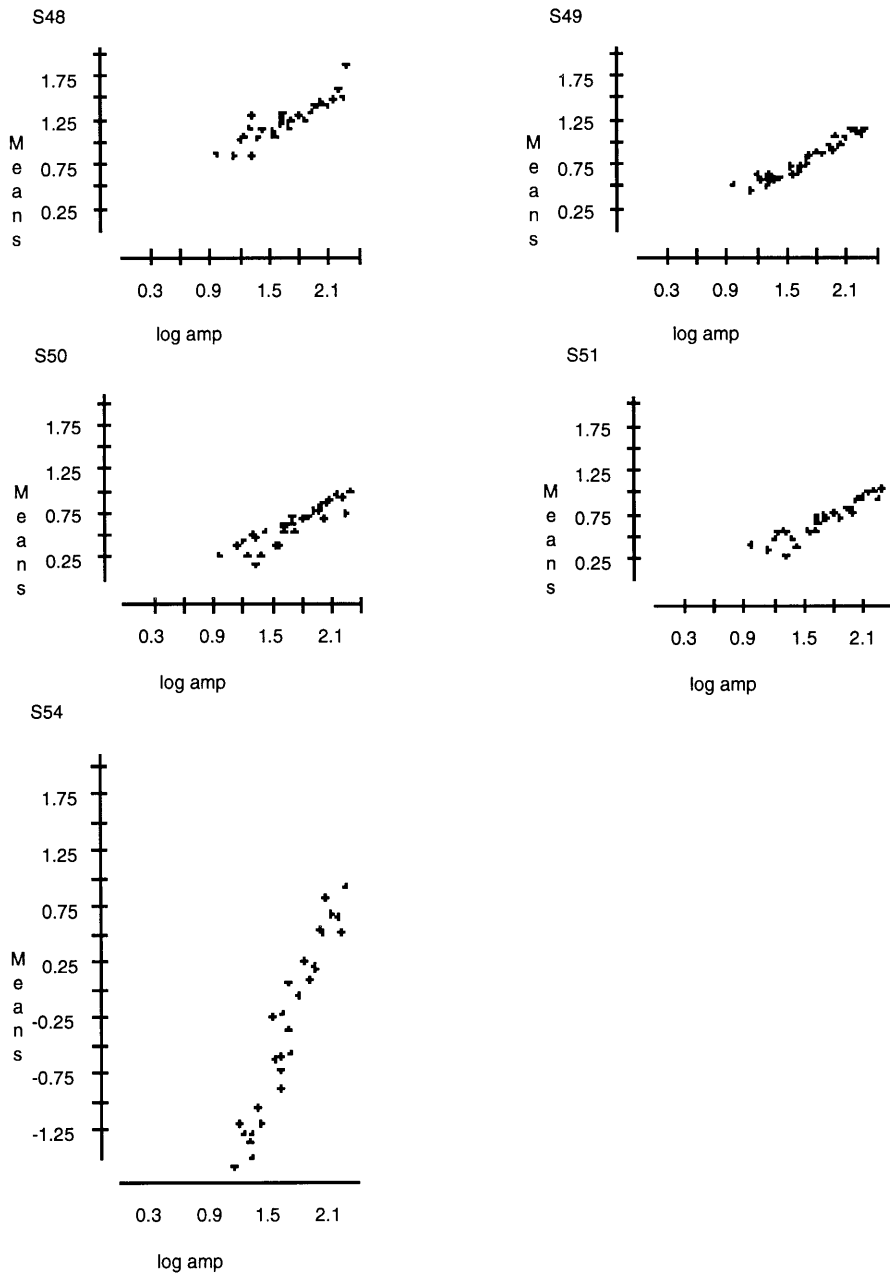

con't

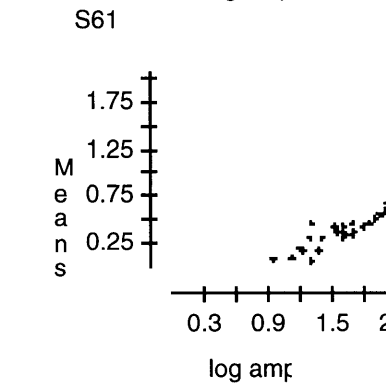
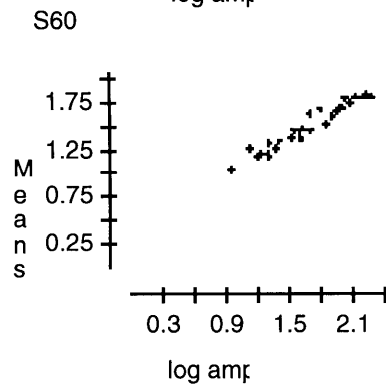
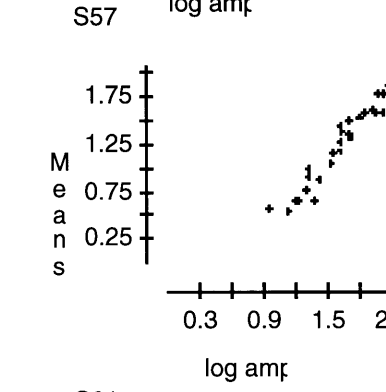
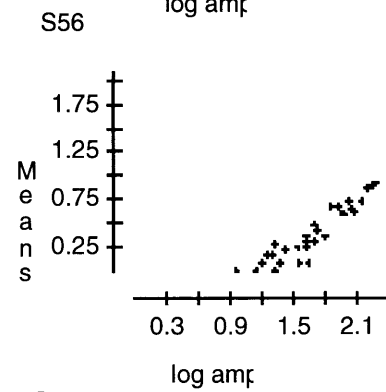
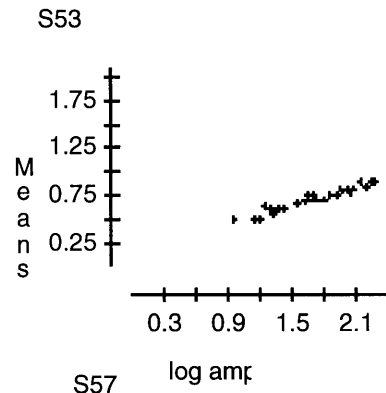
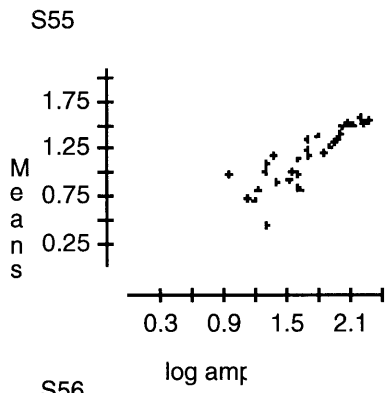

con't

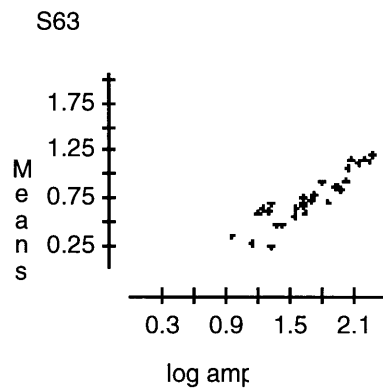
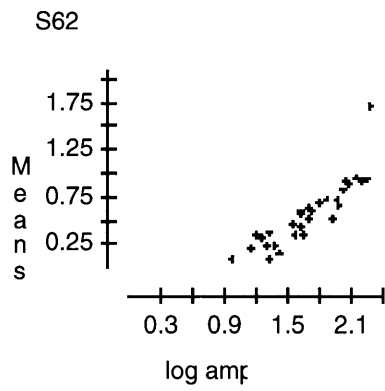
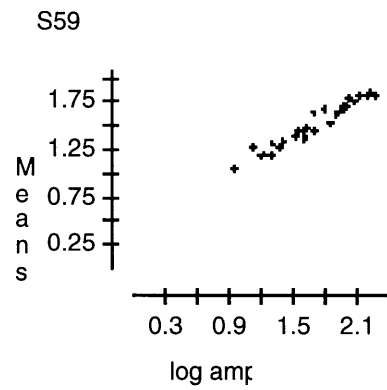
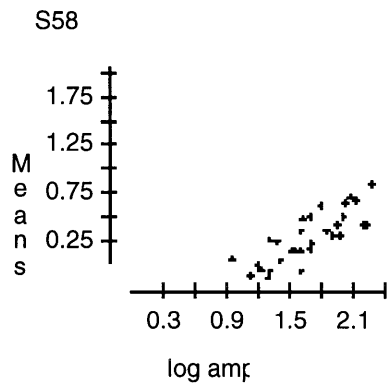

5.3.4 Hand Motion

Subjects used back-and-forth, circular, and erratic hand-motion strategies. These observations were made near the beginning of the session. Slow motions may be indicative of a contour-following or feature-finding strategy Table 7 lists the recorded motion strategies, and also any unusual grips used by subjects as they held the joystick handle.

TABLE 7.

S#	motion description	S#	motion description
S48	lateral	S57	circular; changed to slower lateral
S49	circular	S58	circular and lateral
S50	lateral	S59	lateral pinch grip ^a , changed to flat hand
S51	lateral	S60	lateral slow tight grip
S53	lateral	S61	circular and erratic motion
S54	lateral light touch fairly slow	S62	more lateral, some circular erratic
S55	somewhat circular	S63	lateral slowly
S56	lateral pinch grip		

a. pinch grip: the subject held the joystick handle ball between the tips of the index finger and thumb, with the palm held high above the ball.

5.3.5 Subjects' Verbal Descriptions of Roughness Criteria and Localization of Textured Surface

Some of the subjects volunteered comments on their perceptions of the stimuli or on introspective issues in creating a roughness scale. After all runs were completed, I asked some of the subjects

the following questions: “Did you feel surfaces?” “What can you say about where they were located?” and “Can you tell me about what was easy and what was difficult about this task?”

These questions had several goals. First, verbal comments provided an additional check that subjects were convinced that they were feeling textured surfaces. Second, I was interested in gathering data on the effectiveness of the simulation and physical setup at localizing the surfaces near the hand. Third, problematic issues in scaling roughness over such a wide range of feature sizes could be explored through the comments on the task. Fourth, verbal data about haptic perceptions evoked by the texture simulations are rich and interesting; they uncover perceptual and affective phenomena and help in planning further exploration of haptic perceptual space.

Several subjects said, either voluntarily or in response to a question, that it seemed difficult to create a uniform rating scale, because there were different *kinds* of roughness involved. Several of the responses specifically discussed the notion that they separated resistance judgements from spatial judgements; furthermore, some of the subjects discussed what is apparently feature height and interfeature spacing. One even drew a diagram showing a wavy cross-section, with height and spatial period highlighted.

Here are some examples: (V: indicates a voluntary comment usually early in the session, P: indicates response to the experimenter questions at the end of the session). These are transcripts of written notations during the session, and may have missing words.

S48: V: what do I mean by rough? Frequency, magnitude; few, far; two parameters
<at end of run 3>: now 3 parameters
- pure resistance (mechanical resistance in wand)
- spacing of bumps
- magnitude depth of bumps

S57 P: didn't feel like surfaces using a stick over the surface. location quite near hand.
stick with small ball on end 40-50 cm. difficult to assign roughness. 2 factors [S drew picture showing waves with wave height and wave period marked!]

S58 V: It's tricky P: Everything is relative. hard to pull - but not rougher underneath *or* really rough, tried to compensate for that, higher rating than if silky, but not as high as if really rough.

S59P: different types 1: corduroy 2: rougher- pebblier
didn't know whether to use depth/crest or overall amount of shakiness
using depth more - rougher rating
rather than breaking up between lines
2 different types : twill and deep wale corduroy, asphalt

S62P: surfaces believable. on the ground, riding a bike - hitting big pebbles or big rocks, or ice skating, full body experience
[I used a] 1-10 scale, higher numbers 8,9 easy, 5 easy, 1 easy,
2, 3, 4 distinction was really complicated: ease of flow; I was making figure-eight, determined whether 4 or 2
5, 8, 9 was size of bumps few big ones how far down did you fall or a lot of ones

These comments underscore that spatial information, as well as force amplitude (described as resistance by some subjects), is recovered at some perceptual level and is important cognitively to the subjects. It may be that a multidimensional approach (in contrast to a *roughness* classification and scaling paradigms) to classifying even this simple set of texture stimuli would be more revealing.

In a context of haptic perception of some common surfaces, Hollins, et al. [Hollins93] note that subjects' *descriptive* ratings for the roughness-smoothness dimension is closely correlated with their descriptive ratings for flatness-bumpiness. This may explain in part the difficulties in verbal communication about highly salient qualitative factors about this set of grating textures. Subjects use terminology about bumps, bumpiness, roughness, and smoothness, which must also be unpacked in order to understand whether they are alluding to complex notions about surfaces, for example, distinguishing "underlying bumps" from superimposed "rough texture."

Descriptions of localization were recorded from 10 of the subjects; 2 subjects said surfaces were always right under their hand or the ball, 5 subjects mentioned mediation through a tool or stick, 1 localized the surfaces to the ground and 2 did not localize

5.4 Discussion

5.4.1 Dominance of Force Amplitude in this Context

Maximum lateral-force amplitude seems to provide a satisfactory model for roughness estimates in this situation despite the wide range of spatial periods of these stimuli (some larger than are considered “textural” by subjects in experiments with real world textures) and the apparent salience of qualitative distinctions among the stimuli.

Arguments about the usefulness of this result for haptic interfaces to computational environments:

- This relationship between force amplitude and roughness can be useful in haptic simulations. This information could be used to dial in a set of textures of differing roughness. For example, a grating texture with a particular period and different forces could be used to create a set of predictably different textures. This might not be equivalent to the casual descriptor “roughness” in many situations, but it could be a good technique for making distinguishable textures for a user-interface application.
- This simple relationship is disappointing because the textured surfaces created solely with force-amplitude variation do not have roughness characteristics that mimic real world textures, and thus cannot provide a direct building block for a kit to simulate real materials. Perhaps these stimuli are too diverse qualitatively (see Chapter 4) to allow realistic roughness cues to prevail (even if those cues are ordinarily different for small and large feature sizes). The power of the magnitude-estimation paradigm is that subjects can find a property to which they are perceptually sensitive. To make rough surface simulations in a wide variety of contexts requires further investigation.

5.4.2 Human hand sensitivity to force

In these experiments, force is delivered to the whole hand through the grip on the joystick ball handle. It is useful to relate the sensitivity observed here to other results on hand and finger sensitivity to force.

It is difficult to find experimental data for the hand as a whole. JND for sensitivity to grip force on the fingers has been reported at .5N (1.8 oz.) [Shimoga93a] and at 10-15% of reference force for forces from 2.5 to 10 N [Tan92] (10% at 2.5 N (9 oz.) is .25 N (0.9 oz.)). In contrast, Schmolt saw

a greater sensitivity to force on the hand while holding a small, vibrating force-feedback joystick (maximum force output approximately 2.5 oz.); showing 7 bits of sensitivity in this range, implying a JND of at most .02 oz. [Schmolt91].

In the work in Chapters 4 and 5, force amplitudes output by the joystick range from .7 oz. to 13.6 oz. The smallest force difference between maximum forces for any two stimuli is .07 oz. Within each stimulus, there are 5 levels of force separated by approximately 20%. For the weakest stimuli, this is about .14 oz.; for the strongest about 2.7 oz. These fall within the range of the discrimination data above. This is a good plausibility check on the result in this chapter, that subjects' discriminate and scale roughness at the force amplitudes presented in this experiment.

5.4.3 Comparison with tactile roughness factors

One question is whether modeling textured surfaces in this way gives us access to a range of perceptual surfaces that is a subset of, or equivalent to surfaces perceived in ordinary real-world situations by haptic processes. The dissimilarities between the sensing modes for these stimuli and for real-world textures perceived with the fingertips suggest that the cognitive process of texture perception is flexible enough to provide a meaningful percept of roughness in an alternative sensing environment.

The robust relationship between force amplitude and perceived roughness extends from spatial periods of .7 mm to 1 cm. In contrast, subjects are uncomfortable rating real-world gratings as "rough" above 3.5 mm [Lederman, personal communication]. We have seen in Chapter 4 that subjects' qualitative impressions of the nature of the surfaces may also involve this size boundary. Subjects' comments in this experiment also point to "different kinds of roughness" and other difficulties in assimilating all the stimuli to a single perceptual dimension of roughness. Nevertheless,

in the context of roughness rating, roughness coding as force amplitude is robust over a size range of textures that extends beyond the real-world range.

5.5 Conclusions

From the results of this experiment, a psychophysical function from force amplitude to perceived roughness is obtained for regular grating textures. This may make it possible for computer simulations to “dial in” rough materials according to a specification. However, the qualitative distinctions that subjects note between textures of varying feature sizes may become more prominent in an application context, wherein textures are supposed to resemble particular real materials more closely.

The next chapter discusses an experiment designed to further explore the salience of both force-amplitude and spatial-period factors in the perception of roughness for simulated textures. Subjects in the experiment in this chapter, and also in the next chapter, eagerly discuss qualitative distinctions between textures. The discussions underscore the multidimensional nature of texture, of which roughness is only one dimension. It is important to unpack the nature of the other dimensions or qualities of texture in order to create useful simulations.

5.6 Comparative data for Earplugs and No Earplugs

5.6.1 Sound Cues

Four of the fifteen experimental subjects wore earplugs (M.A.X. brand) in order to obtain data on whether acoustic cues affect the results of this experiment. Note that even with earplugs, some audio cueing was probably still available through bone conduction, since the subject was gripping the mechanical joystick. The proportion of audio signal available through bone conduction is unknown at this time.

The slope of a regression of roughness estimates against force amplitude is steeper for the earplug cohort (1.2) than the no-earplug cohort (.6); subject S54 in the earplug set has a particularly steep slope (2.1). The slopes of the earplug cohort's psychophysical functions were compared with a random sample from the no-earplug cohort. The comparison reveals no statistically significant difference (paired t-statistic = -1.9). Thus, the data for earplug and no-earplug subjects have been combined in the rest of the analysis.

6 Qualitative Roughness

6.1 Qualitative Roughness Experiment: Exploring Perceptual Salience of Force Amplitude and Spatial Period for Roughness Similarity

This experiment was aimed at further exploring perceptually salient aspects of texture. We chose to explore roughness for several reasons: first, it is an aspect of texture that is mentioned in casual descriptions of texture; second, it is an explicit descriptor of texture in machine-shop practice (surface finishes, sandpapers); third, it is an apparently separable percept in experimental situations; and fourth, factors contributing to roughness perception of real world stimuli have been studied, rendering that work available for comparison with our simulated textures.

By analogy with real-world grating textures, I hypothesized that spatial period¹ and force amplitude are factors in roughness perception of grating textures. The experiment in the previous chapter highlights force amplitude as a factor in roughness perception; the verbal comments from that experiment are consistent with the interpretation that there is perceptual attention to spatial factors.

A similarity-sorting technique was used to explore the salient factors for haptic perception of roughness of *gratings* (one-way stripe) textures. Texture stimuli were chosen with 4 force amplitudes (the maximum lateral force that the subject feels while exploring the texture) and 6 spatial periods. Subjects sorted the textures first into 2 roughness-similarity groups, then 3, and then 4.

This method was chosen because it allows subjects to freely manipulate the texture stimuli and providing qualitative data about the salience of the factors chosen. The 2-group sort can reveal primary salience of one experimental factor (if a subject splits the stimuli into groups cleanly corre-

1. In real-world textures, groove width is a factor in roughness but overall spatial period is not. However I believed that in the case of simulations, the haptic systems would still be sensitive to spatial factors but likely to recover overall spatial period.

lated with different levels of that factor). The 3- and 4- group sorts allow analysis of phenomena such as secondary salience of another factor or refinement of grouping within one factor. I was also particularly interested in the subjects' introspective analysis of their grouping criteria. I asked for verbal descriptions of the groups in the 4-group sort and found that the sorting task prompted extensive comment from subjects about the way the stimuli felt to them and about their grouping criteria.

Data were analyzed by direct inspection of subject groupings, cluster analysis of the sorted groups into which stimuli were placed, and comparison of groupings with prototypes.

Individual sorting strategies (groupings) were examined, along with their relationship to verbal comments from the subjects on their sorting criteria for their 4-group sorts. The verbal comments provide information about descriptive terms and concepts evoked by these stimuli, hints about subjects' strategies for forming their groups (refinement, multiple perceptual sorting criteria), and evaluation of difficulties with the task. These verbal comments and additional information about hand-motion strategy are used as a context for discussion.

At the end of this chapter I evaluate the apparent high perceptual salience of force amplitude with possible secondary salience of spatial period, as well as the limitations of the current experiment.

6.2 Method

6.2.1 Apparatus

The joystick setup was the same as for the Texture Confidence experiment in Chapter 3 with a few minor differences. First, the black circle was removed from the joystick shaft to maximize the haptic workspace. Second, the experiment took place in a different cubicle within the laboratory.

6.2.2 Subjects

Fifteen subjects were paid with ice cream shop gift certificates for participating. They were recruited with flyers and e-mail through the MIT community. All were experimentally naive. Ages ranged from 20 to 59 with a mean of 30 years. There were 9 male and 6 female subjects, of whom 13 reported being right-handed, 1 left-handed, and 1 subject was not reported.

6.2.3 Stimuli

The stimuli for this experiment were chosen with ranges of feature size and amplitude that form a superset of those ranges of the *grating* stimuli used in the Texture Confidence experiment (Chapter 3) and that bracket the ranges of the gratings stimuli in the Quantitative Roughness experiment (Chapter 5).

I used a different, cleaner technique (Version-2 textures) for generating the grating stimuli in this experiment and the Quantitative Roughness Experiment than in the Texture Confidence experiment. The new technique generates all sizes of grating stimuli from one scalable “seed”, scaled to different sizes. These stimuli of different sizes are similar in shape, thereby eliminating some artifacts of size, and smaller feature sizes can be generated. A smoothing filter is applied only once to the seed at high resolution. In general, the choice of smoothing filter affects the shape of the gratings (the smoothed shape derived from the underlying square-wave cross section). In this case that shape is the same for all stimuli, rather than being subtly different for different size gratings. This technique is illustrated in more detail in section 3.5.2.

The 12 stimuli are described in Table 8. Spatial period and force amplitudes are listed in the table. The gratings have equal hill and valley widths (i.e. half of the spatial period).

TABLE 8.

Stimulus Name	force-amplitude level (arbitrary units)	command amplitude (range 0-2048)	physical force-amplitude, N(oz.)	spatial period (mm)
a1p7	1	40	(0.7)	.7
a3p7	3	120	(2.1)	.7
a3p12	3	120	(2.1)	1.2
a3p25	3	120	(2.1)	2.5
a3p50	3	120	(2.1)	5.0
a3p100	3	120	(2.1)	10.0
a10p7	10	400	(7.0)	.7
a10p12	10	400	(7.0)	1.2
a10p25	10	400	(7.0)	2.5
a10p50	10	400	(7.0)	5.0
a10p100	10	400	(7.0)	10.0
a19p100	19	760	(13.4)	10.0

6.2.4 Force amplitudes of stimuli

Force-amplitude levels are notated a1, a3, a10, a19. This is a notation for the level of output force corresponding to a particular maximum lateral force. The amplitudes are output by the texture simulation software to command the joystick force. As the subject moves the joystick over a patch, forces are applied to the hand. *Command amplitudes* are the numerical force output commands to the joystick hardware module, and are tabulated in joystick output units (0-2048). In the case of the textures used in these experiments, the forces are dependent on position only. What is the best model for the forces that are relevant to roughness percepts? Some candidates include: maximum

lateral (x direction) force, maximum x-y force, average force, average force accounting for true trajectory, maximum force accounting for true trajectory, and so on. As a first model I have chosen the maximum force encountered, excluding a thin rim around the edge of the patch. I do not attempt to account for the actual trajectory of the hand, assuming that most subjects adopt a strategy where they scan the entire central region of the patch and are exposed to the forces for approximately equal times. This is equivalent to an assumption that the subjects scan with approximately constant speed, in a back-and-forth or circular motion.

Physical force amplitude is the maximum output force. These forces have been computed by multiplying the command amplitudes with the appropriate values for motor torque and joystick length. A calibration check was obtained by measuring the force output at the joystick handle at several joystick absolute amplitude levels.

These levels were chosen so that a1 was barely perceptible, and a3, a5, and a19 levels were mid-low, mid-high, and highest, respectively, relative to Chapter 5 stimuli.

6.2.5 Procedure

The experiment was designed as a roughness-similarity, group-sorting task — 2-group, 3-group, and 4-group. Subjects were given a haptic display of twelve patches with a visual display of black, randomly-numbered patches corresponding to the haptic display. They were asked to sort the patches successively into two, three or four groups according to how they seem “similar in roughness”.

Figure 22 shows the setup for this experiment.

FIGURE 22. Experimental setup for sorting task (qualitative roughness)

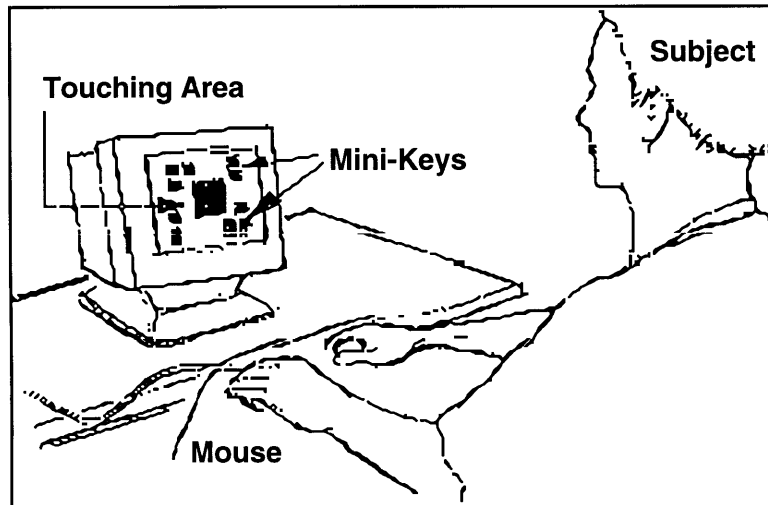

The subjects read the following instructions:

What To Do

We are trying to create simulations of surfaces that you can feel as part of our research in creating "virtual worlds" using computer simulations.

You will see a large area in the middle of the workspace, this is the **touching space** where you can feel surfaces. You can feel surfaces in your workspace, as you will be shown by your study director.

You will also see many small squares in the workspace. These are your **mini-keys** for choosing the different surfaces to feel. Each time you move into a mini-key, its surface pops into the touching space for you to feel.

You can also use the mouse to move the mini-keys and organize them in your workspace.

First we will ask you to get used to feeling all the surfaces and moving the mini-keys.

We may also ask you to sort the surfaces into groups according to their similarity to each other in how rough they feel. For example, if we ask you to sort them into two groups, create two groups where all the surfaces in each group feel “most similar” to one another in roughness, and the groups are “most different” from each other. You do not have to put the same number of surfaces in each group, use your own sense of what surfaces feel similarly rough.

There are no right or wrong answers! Please sort the surfaces into groups according to the similarities and differences in the way they feel rough to you!

Your study director will let you know each time the surfaces are ready for you to sort. When you are done, let the study director know so that they can let you go on to the next sorting group.

The touching area was a rectangular region with sides of approximately 8 cm (3 in.). The mini-keys, representing the twelve haptic surfaces, were squares with sides of about 2.5 cm (1 in.). To feel a surface, the subject selected a mini-key with the mouse, and felt the surface in the part of the joystick workspace corresponding to the touching area.

This somewhat unusual user interface is the result of compensating for problems with several other schemes that were tried in pilot tests. The basic problem is that the haptic workspace is limited. I wanted subjects to be able to randomly access any of the patches, as though they were real patches of material laid out on a large table. However, the patches also need to be at least 2.5" in size (preferably larger) to accommodate subjects' natural lateral and circular hand motions as they explore simulated textured surfaces. I compromised by creating the mini-key/touching-area system. Although this interface would seem to represent a significant cognitive load, anecdotal observation showed subjects were comfortable with manipulating the patches in this way. Note, however, there may be extra errors in the subjects' groupings because of limitations of this interface for two reasons:

- Mini-Key Selection error. Subjects may feel an unexpected simulation within the touching area because they have swept the mouse through an unintended mini-key on the way from an intended mini-key to another position.

•Mode Change Load error. Subjects may avoid rechecking their groupings as completely as they would were this a set of real materials moveable with the hands, because it is more trouble to use the mouse mini-key mechanism and it requires switching between a more natural haptic modality (joystick) to another one (mouse selection).

The mini-keys were labelled with random three digit white numbers, which were automatically re-assigned randomly before each presentation of stimuli for a group sort. The intention was to make the mini-keys visually distinguishable using visual cues that did not resemble textures or natural surface designs. Some subjects asked whether the numbers were meaningful or consistent, but when told that the numbers were randomly assigned and would not stay constant between sorting tasks, they did not appear to attend to them. Neither unsolicited nor solicited comments from the subjects about the surfaces mentioned the numbers.

The experimenter asked for questions, allowed free practice in coordinating mouse and joystick motion, and then instructed the subject to perform a 2-group sort. The resulting patterns of mini-keys were saved, then the subjects were asked to sort into three and then four groups. The patches were randomly repositioned and renumbered on the screen before each sort.

After the subject completed all the sorting tasks, the experimenter asked for a verbal description of the four groups. These descriptions were noted by hand in a notebook. Some of the subjects also volunteered descriptions at that time of their two- and three-group sorts.

The subjects were not restricted in sorting time. None of the subjects' times to complete the entire procedure exceeded 45 minutes.

Figure 23 is a reconstruction of a scene from a finished four-group sort¹, which illustrates one way in which a subject used the available workspace for four roughness-similarity groups.

1. This set up photo has ten stimuli from pilot study data rather than the full twelve, and a volunteer model for the subject.

FIGURE 23. 4-group sort

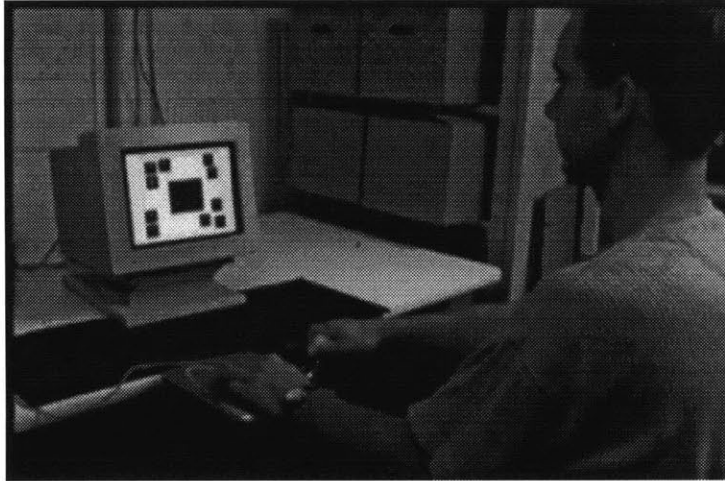

6.3 Results and Discussion

6.3.1 Summary

- **Amplitude/Period:** Force amplitude is the primary salient factor in roughness-similarity judgements. Spatial period may be a secondary salient factor
- **Transition near 2.5 mm:** Groupings tend to separate stimuli with spatial periods above 2.5 mm (5 and 10 mm) from those below (.7 and 1.2 mm), with 2.5 mm stimuli appearing to be a transitional case. Although this phenomenon cannot be fully interpreted here, it may represent the region of transition between textural elements and discrete features.
- **Characteristic Groupings:** Two phenomena point to the complexity of interaction between spatial and force-amplitude factors in the perception of qualitative classes of textures. First, the lowest-amplitude, small-period stimulus tended to be grouped with larger period stimuli (also low-amplitude) rather than those closer in period. Second, the high-amplitude, high-period stimuli appear to group together most robustly.

These findings are based on evidence from visual interpretation of the group-sorting data (Figure 24, Figure 26, Figure 28, and Figure 30), statistical cluster analyses (Figure 25, Figure 27, Figure 29), informal coding of group data into classes by salience factor, and verbal descriptions from the subjects of the nature of their 4-way sort (Figure 31, Figure 32).

6.3.2 Notes on Visual Interpretation of Individual Sorting Data and Cluster Analysis

The grouping results of this study are depicted in Figure 24, Figure 26, Figure 28, and Figure 30. Each rectangular diagram depicts the stimuli as dots in a matrix of their force-amplitude levels and spatial periods. Contour lines are drawn to show the group boundaries for each subject at each sorting stage. Figure 30 shows all groupings in sequence for each subject. The other figures cluster all the 2-, 3-, and 4-group sorts for comparison. In these figures I have arranged the diagrams to visually cluster those that are similar to one another.

This is a convenient way to look at the data, but beware of visual illusions in the initial interpretation of the data. For example, group boundaries have been drawn, where possible, with horizontal lines for consistency. Since force amplitude is on the vertical axis, and thus horizontal lines are amplitude boundaries, this accentuates the extent to which groups appear to correlate with force amplitude.

Cluster analysis is a way to algorithmically summarize the “closeness” with which stimuli are grouped together. Each stimulus is first considered to be its own cluster (on the left in the figures), then the clustering algorithm repeatedly creates new clusters by combining a previous cluster with its nearest neighbor. In this experiment, the nearest neighbor is the stimulus that appears in the most similarity groups in *common*¹. In the last repetition of the algorithm, all stimuli are clustered together in one big cluster (on the right in the figures). Although the extremes of the cluster diagram (left and right) are always the same, the intermediate levels give a visual and algorithmic sense of the “closeness” with which the stimuli are grouped. Thus, at any level of the cluster analysis, stimuli appearing in the same cluster are often grouped together in the subjects’ similarity

1. The particular algorithm used for the cluster analyses in this chapter is called single-linkage clustering, in which at each stage of clustering, if clusters A and B have been combined to form cluster C, the distance between cluster C and D_i is calculated as the minimum distance between D_i and subclusters A and B. A new cluster is formed from C and the closest D_i .

groups. The more leftward the level at which stimuli are clustered together, the more tightly they are linked in the subject groupings.

6.3.3 Force Amplitude and Spatial Period as Factors

6.3.3.1 Force Amplitude

Visual inspection of the grouping patterns provides a great deal of information about the nature of subject grouping. Figure 24 shows the grouping patterns for all subjects' 2-group sorts.

A strong preponderance of groupings in the 2-group sort look like a binary split between low- and high-amplitude stimuli. (Low-amplitude stimuli are those with A1 or A3 values). Nine out of 15 subject groupings split on this boundary, with three additional groupings differing in classification by only one stimulus. (Groupings for the remaining three subjects each differ from the amplitude-split grouping by two, three, and four elements).

Figure 25 shows the cluster analysis for 2-group sorts. This analysis of 2-group sorts also shows the binary split on force amplitude, evident in the assignment of all amplitude A1 and A3 stimuli to one top-level cluster and all A10 and A19 stimuli to another.

One interpretation is that force amplitude is the most perceptually salient factor for roughness perception in this sorting task, leading to the primary binary grouping for most subjects.

This is further confirmed in the 3- and 4-group sorting patterns and in cluster analysis of the 3- and 4-group sorts.

Figure 26 shows the grouping patterns for all subjects' 3-group sorts. Figure 27 shows the cluster analysis for 3-group sorts. The cluster analysis topmost grouping again reflects a split between A1, A3 stimuli and A10, A19 stimuli; the same amplitude split apparent in the 2-group sorts. Strong

horizontal lines in all subjects' 3-group sorts also point to perceptual salience of amplitude. The patterns of S73, S68, S74, S72, and S69, with multiple horizontal lines, are especially suggestive of further refinement of amplitude discrimination. The patterns of S80, and S76 are particularly suggestive of an "anchor" grouping emanating from the high-amplitude A19P100 stimulus.

Figure 28 shows the grouping patterns for all subjects' 4-group sorts. Figure 29 shows the cluster analysis for 4-group sorts. Again, a binary amplitude split is evident in the cluster analysis. The grouping patterns of S75, S81, S72, S74, S76, S80, S71, and S73 are particularly suggestive of amplitude discrimination refinement, perhaps in combination with anchoring around the A19P100 stimulus.

The relative salience of force amplitude is highlighted in 2-, 3- and 4-group sorting data, shown together for each subject in sequence in Figure 30. The consistent appearance of strong horizontal lines, suggestive of amplitude splits, can be seen throughout.

Many of the verbal descriptions given for the 4-group sort (Figure 30) support the notion that subjects are making judgements of stimuli based on force amplitude. For example, 7 subjects explicitly discuss "resistance" or "hard to move" as criteria; another mentions springiness.

FIGURE 24. Pictures representing the 2-group sorts for all subjects

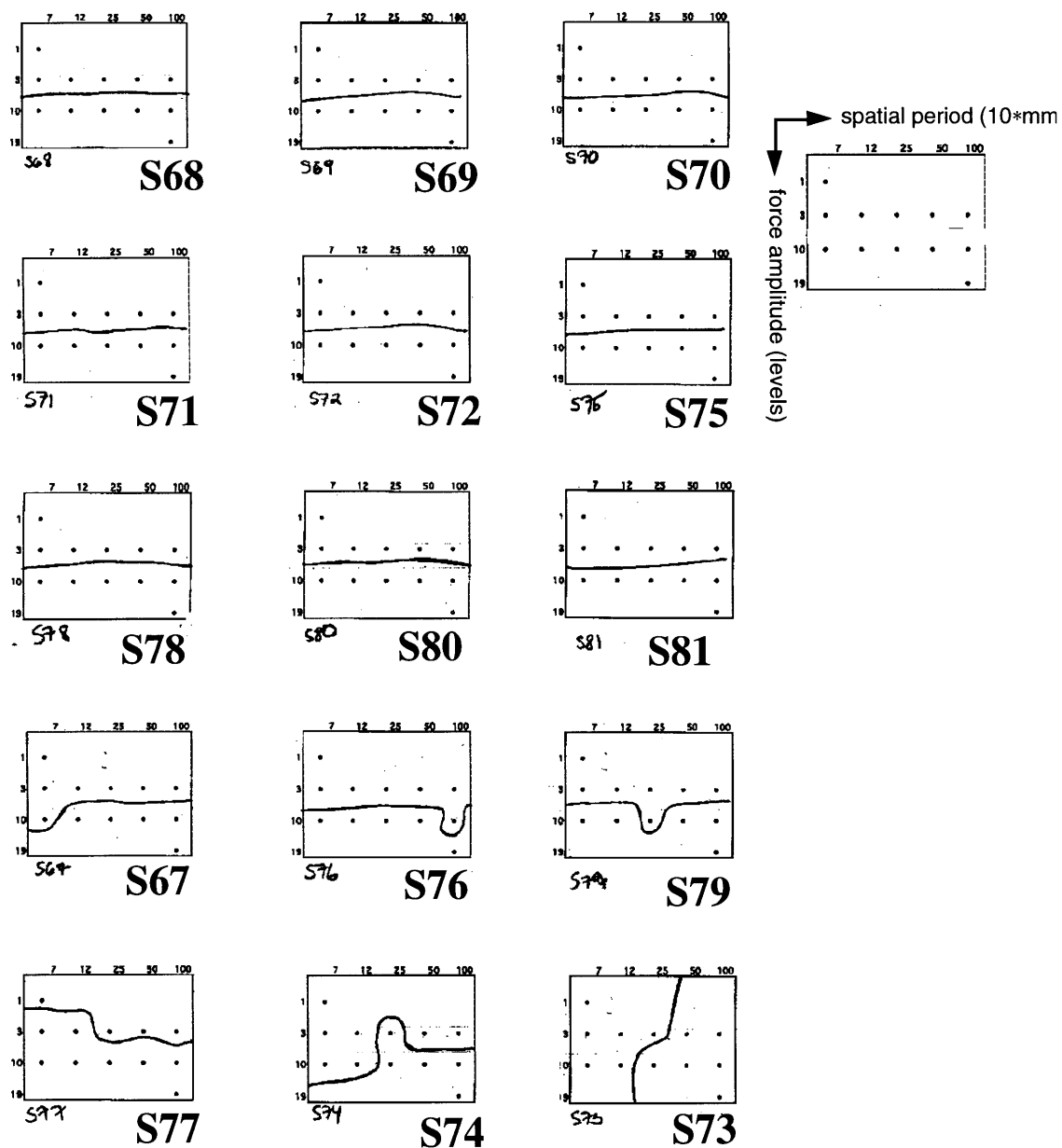
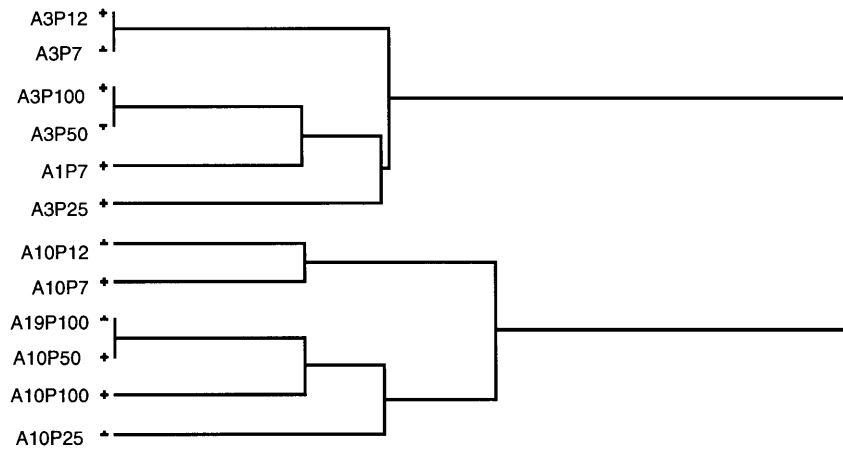

FIGURE 25. Cluster analysis of 2-group sort



Cluster, 2-group sorts

FIGURE 26. Pictures representing the 3-group sorts for all subjects

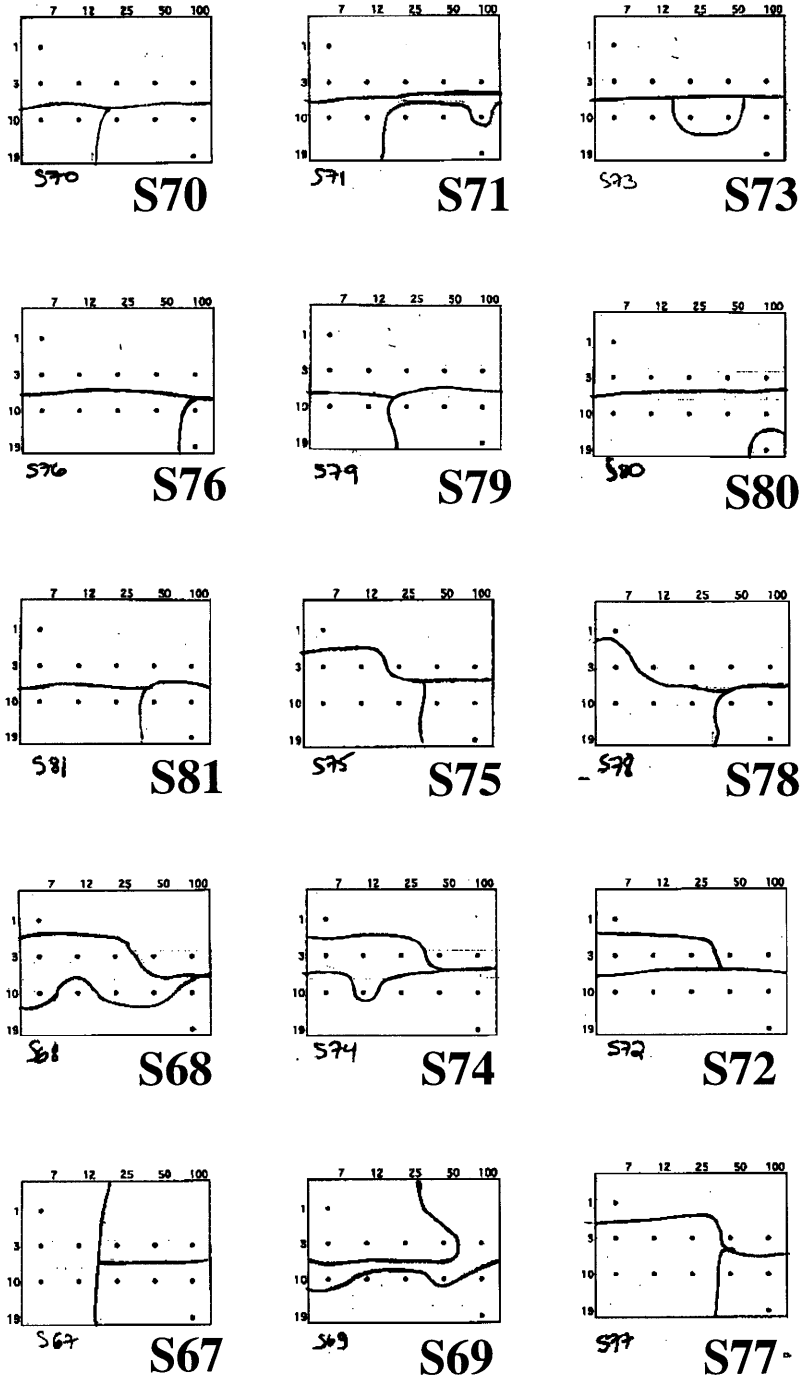
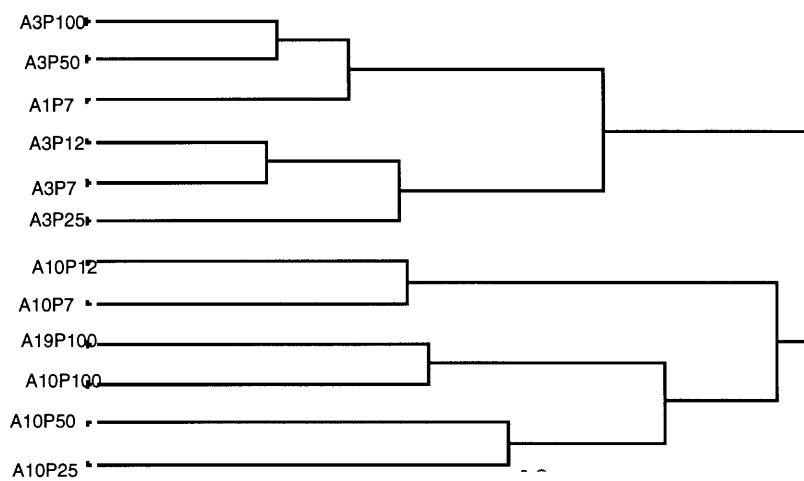

FIGURE 27. Cluster analysis of 3-group sort



Cluster, 3-group sorts

FIGURE 28. Pictures representing the 4-group sorts for all subjects

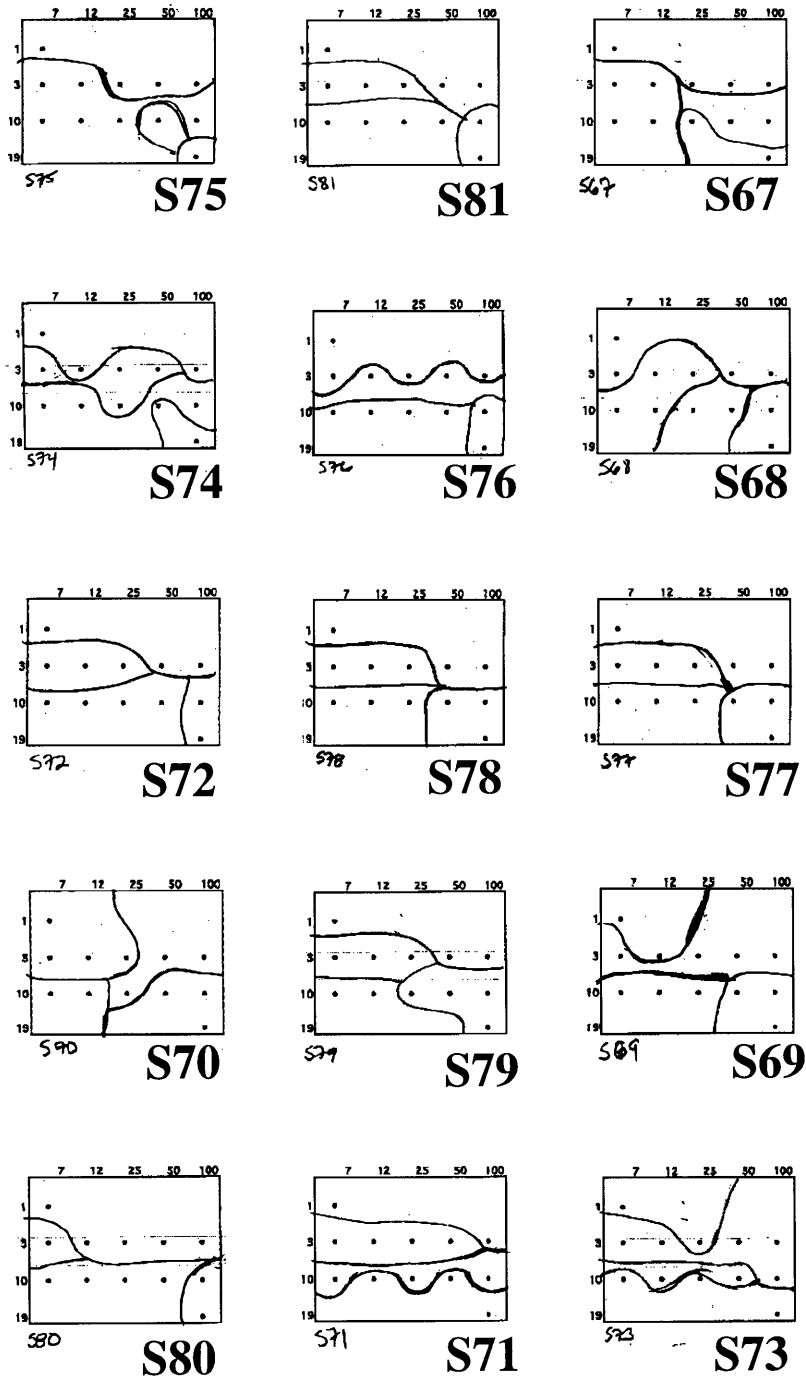
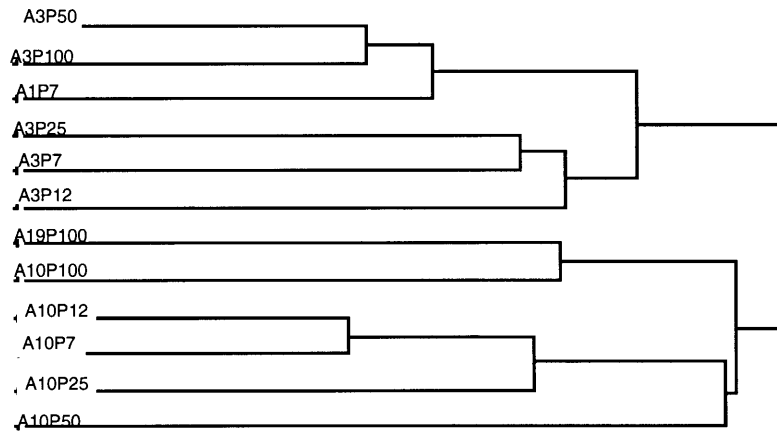

FIGURE 29. Cluster analysis of 4-group sort



Cluster, 4-group sorts

6.3.3.2 Spatial Period

Spatial period may be a salient factor for some subjects.

In the 2-group sort (see Figure 24) there is only one subject, S73, whose groups completely correlate with a spatial-period distinction. Note, however, that subject S73 had an idiosyncratic exploratory style essentially tossing the joystick handle without maintaining hand contact at all times. With such an exploratory strategy, it is difficult to understand how spatial information could be discerned, (although force information from bounce-back of the joystick seems plausible). Thus, this grouping remains puzzling. This subject's 3-group and 4-group sort appear to correlate more strongly with force amplitude (see Figure 30). Perhaps the duration of hand contact in the strategy changed; perhaps this strategy uncovered haptic artifacts of the stimuli that are difficult to compare with those felt by someone who maintained hand contact.

Subjects S67, S70, S77, S78 and S79 have both 3- and 4-group sorts that indicate notable correlation with a spatial period split (Figure 26 and Figure 28.)

Of the subjects whose 3- and 4-group patterns support a spatial-period salience interpretation, verbal descriptions are varied. Verbal descriptions from S70 support spatial-period-based judgements. Subject 70 also had the following suggestive comment: “At first [I did the sort] on size of bumps; [I] couldn’t do four [groups], then noticed spacing.” The descriptions from S67 are difficult to interpret. S77’s description points to both an amplitude continuum and a sense that the high-amplitude large-period group fits a different pattern. S79 describes a continuum of affective judgements and mentions roughness, bumpiness, and smoothness. The descriptions from S78 lay out a matrix defined by smaller-bigger and sharp-round; the small-big division splits the stimuli across a force-amplitude boundary and the sharp-round division splits the stimuli across spatial period, with the exception of the “smaller, round” group which includes A1P7, A3P50 and A3P100.

S67 is the only subject who classified all low-period stimuli, including A1P7, in the same 3-group. However, in S67’s 4-group sort, A1P7 is classified with higher period stimuli,

Two overall patterns are noticeable in 4-group sorts. One pattern can be interpreted as continued refinement of amplitude-based sorting (e.g. S76, S71). The other is a characteristic pattern of four quadrants with amplitude split between A3 and A10 levels, and a spatial split centered around P25 (2.5 mm). This may reflect emergence of spatial period as a salient grouping criterion. Of the four clearest quadrant examples (S78, S69, S70, and S77 in Figure 32), two sets of comments are suggestive of a matrix of two factors. However, S69 and S77 have more of a continuum characterization of levels in their verbal descriptions.

6.3.4 Quantitative coding procedure for analysis of grouping patterns.

I developed an additional analysis tool for coding the similarity groups in the sorting experiment: a *distance-metric* algorithm computes the distance of a subjects' grouping pattern from a prototype; the distance is the number of stimuli that would have to be moved to make the grouping into the prototype. With suitable prototypes for the 2-group sorts representing pure amplitude-based grouping and period-based grouping, the distance metric creates a quantitative coding that corresponds with the above analysis of amplitude and period salience. This coding procedure should be used for all grouping levels in any version of experiments on material properties using the progressive similarity grouping method.

6.3.5 Verbal description framework

It is interesting to note that most subjects' verbal descriptions (Figure 31, Figure 32) use physically or perceptually based terminology, e.g. "roughness," "resistance," "sharp," "smooth," "hard," "soft," and "bumpy." The salience of force is especially apparent in "springiness" and "rebound." Others use concrete comparisons to representative objects such as "gratings," "gears," "marble," and "sandpaper." S79 had affective descriptions and said that the "smoothest, most pleasant" and "least enjoyable, bumpiest and roughest" groups were "easier to describe." The other two groups, "kind of mixed, not as bumpy" and "not too bad, resistance, not unpleasantly bumpy" were "harder to describe." Affective components of haptic perception are of great importance and must also be accommodated in the material/perceptual framework as perceptually-based or possibly representative-based descriptions.

6.3.6 Transition near 2.5 mm

Cluster analysis (Figure 25) and inspection of 4-group sort data reveal a strong tendency for stimuli of spatial period 5.0 mm and 10.0 mm to cluster together, for .7 and 1.2 mm stimuli to cluster

together, and a slightly weaker tendency for period 2.5 mm stimuli to cluster with the smaller ones. (Data from 3-group sorts show closer association of A3P25 with smaller period stimuli and of A10P25 with larger period stimuli.)

Although this phenomenon may not represent a dimensionalization of spatial period, it suggests two putative classes of stimuli, distinguished by a threshold between 2.5 mm and 5.0 mm.

This may be interpreted as a boundary between elements of textural size and elements that are individual features or undulations in an underlying flat surface. Subjects' verbal comments partially support this interpretation, although the factors leading to judgement of roughness-similarity within these groups are more subtle (see next section).

6.3.7 Characteristic Groupings

The quadrant patterns mentioned in section 6.3.3, above, may be better explained by the emergence of two *characteristic groups* which I call **rolling hills** (A3P100, A3P50, sometimes A3P25, and A1P7) and **moguls** (A19P100 and A10P100). The remaining stimuli fall into a group which can be identified as flat textured surfaces.

Rolling hills feel like flat or gently undulating surfaces that may have some texture superimposed. The gratings in A3P50, for example, may be of a large enough period to be perceived as individual surface undulations or features. Moreover, they do not produce enough force to be perceived as "texturally rough". Thus, they may be regarded as similar to a surface that is inherently flat even if it has some texture superimposed, as long as that texture is not very rough (an interpretation of A1P7).

Moguls are also large-period features, and are grouped together by most subjects; “large bumps” is a typical characterization of that group. The amount of force at the A10 and A19 level may be enough to locally characterize the surface as rough.

Cluster analysis (Figure 29) supports the notion that A1P7 is often grouped, somewhat surprisingly, with the A3P100 and A3P50. An amplitude-period quadrant grouping would suggest that A1P7 would be closer to A3P7 and A3P12. Verbal descriptions of this rolling-hills group include “smaller, round” (vs. smaller, sharp), “more silky,” “feel not much,” “softest,” “least resistance,” “very smooth, no resistance,” and “most pleasant, smoothest.”

6.3.8 Limitations of this Experiment

Underlying Assumptions about Perceptual Dimensions of Roughness

This experiment, although suggestive of possible dimensional factors for roughness of textures, is actually inconclusive about the dimensional status and relative salience of force amplitude and spatial period.

The assumptions underlying the interpretation of this experiment in terms of factor salience include: (1) Amplitude is a dimension of roughness perception for simulated texture, (2) spatial period (or something correlated with it) is a dimension of roughness perception for simulated texture, (3) the stimulus set chosen has approximately equivalent discriminability *ranges* and *levels* for the force-amplitude and spatial-period factors, and (4) these dimensions are separable, in the sense of Garner’s classification of dimensions into integral, separable, and configural [Garner76].

There is significant evidence for (1), some for (2), significant problems with (3), and open questions about (4). We review these assumptions, propose methods to correct weaknesses and answer

questions. In doing this evaluation we are able to more concisely pose questions about the perceptual space of simulated roughness and simulated texture.

The experiment in Chapter 5 confirms that roughness scaling by subjects can be largely accounted for by force amplitude. This provides evidence that force amplitude may be a perceptual dimension of roughness for simulated texture.

Subject comments from the experiment in Chapter 5 indicate subject attention to spatial configuration of stimuli and size of spatial features.

In this experiment, we have chosen a range of force amplitudes (0.7 to 13.4 oz.) with 4 levels, and a range of spatial periods (.7 mm to 100mm) with 5 levels, based on the remaining in a high texture confidence region, spanning the range in the previous experiment, which also spans the range of technically achievable and intuitively the largest range of grating textures that can be produced. One thing that was not established in advance, however, is the *relative discriminability* of these two factors, both in range and in intensity of the levels. It may be that the “perceptual distance” between the top and bottom of the amplitude range is larger than between the top and bottom of the period range, and thus leads to response bias in the subjects’ sorting judgements. The bias would be toward making sorting judgements according to differences in amplitude. It may also be that they “perceptual distance” between the amplitude levels (for example, between A3 and A10) may be larger than between the period levels (for example, between P7 and P12). In order to have a conclusive salience experiment, the “perceptual distance” in the dimension ranges and steps must be equivalent.

To clarify this notion, consider an analogous experiment in color perception. Let us say that you have come up with a novel theory of color vision that predicts that “grey” and “red” are two dimensions of color perception space. You decide to do an experiment to determine the relative

salience of black and red for color judgements. You choose 12 color paint chips, which the subjects must sort on the basis of “color similarity.” For the grey dimension, you choose 4 levels: black, dark grey, light grey, and white. For the red dimension, you choose 5 levels: maroon, wine, and 3 intermediate reds. You include one chip of black and one of white, plus the combinations of red and grey at the intermediate levels. Since the steps for grey levels are much more easily discriminated than the steps for the red levels, and the range between black and white is also “bigger” than the range from maroon to wine, one would expect subjects in a similarity sorting task to bias toward sorting on the basis of blackness, even if red level is ordinarily a component of color judgement.

In order to use the sorting paradigm to uncover relative salience of blackness and redness, one would need to match the ranges and levels of black and red so that they are approximately equal distances in their respective one-dimensional perceptual spaces.

Thus, one should step back and pursue the question of roughness discriminability of spatial period separately, using stimuli of differing spatial periods and same force amplitude. A simple approach would be to start with a pair comparison task or ordering task, for stimuli of differing spatial periods. Since there is also evidence that there may be some qualitative split between stimuli of spatial period less than 2.5mm and those of larger size, this would be a chance to experiment separately within those ranges as well as across the range.

It might be possible to examine the question of anchoring by comparing the groupings in this experiment to pilot studies in which no singleton extreme-valued stimuli were present. Unfortunately, the pilot studies already conducted with no extreme-valued stimuli are of limited usefulness as most of the runs involved instructions to sort by similarity on *free* similarity criteria, not on roughness.

Even if spatial period shows further evidence of being a factor in roughness perception in one-dimensional studies, these factors may not be separable, in Garner's sense. In that case, similarity detachments on "integral" dimensions may be guided by perceptual distance in amplitude, period, or a factor that exists as an artifact in our texture space rather than showing primary and secondary saliences as we expect. Or, the detachments may continue to be guided by what we have called "characteristic groups", which I believe may be close to Garner's notion of configural dimensions.

There are other tests such as response time facilitation testing that can be used to clarify the way in which such perceptual dimensions interact for roughness perception. However, it may be more rewarding at this time to turn our attention back to the more global issue of the percepts related to texture in general, and to percepts relating to materials which may be created by a combination of texture and compliance variation, rather than continue to refine the analysis of roughness immediately.

One-dimensional discrimination and ordering studies of spatial feature size, texture type, and force amplitude (with attention to haptic perception but not specifically roughness) might clarify the specificity of these dimensions. In order to find more suggestive evidence of dimensioning of the perceptual space for textures, an exploratory, free-criteria similarity sorting experiment might be a useful way to proceed (despite some of the same problems in stimulus choice).

Effects of Attention to Roughness

Attending to roughness rather than other haptic criteria might cause a bias toward the salience of force amplitude. This set of stimuli possibly contains at least two qualitatively different classes of stimuli; some that are intuitively textural and others that have large feature sizes, larger than those customarily judged along a roughness dimension. Although this is another candidate criterion for most salient haptic distinction among the stimuli, it may not be a distinction that is productive for

discriminating roughness over all stimuli. Subjects may be biased toward finding a percept that can be *temporarily mapped* to roughness, in order to consider roughness-similarity among all the stimuli. This percept or factor should necessarily be characterizable for all the stimuli in order to make comparisons between them. Why force amplitude might best satisfy this is an open question.

We wonder whether subjects' attention to roughness strongly affects the emergent similarity classes in this experiment. That is, are general qualitative classes of haptic surfaces emerging, despite being shoehorned into roughness categories by subjects? Or, does the instruction to attend to roughness bias the salience of physical factors or sensitivity to these factors?

6.3.9 Conclusions: Interaction between Spatial and Amplitude factors in the perception of qualitative classes of textures

In the previous sections, I have characterized my findings on the perceptual salience of amplitude and spatial factors in roughness-similarity sorting. Amplitude seems to be primarily salient for roughness sorting. Spatial period seems to have secondary salience, and there is a possibly a perceptually interesting boundary in spatial feature size near 2.5 mm.

In section 6.3.8 I have evaluated some weaknesses of this experiment and detailed some avenues to better explore the perceptual space of simulated rough texture.

The current experiment, viewed as an exploratory probe into the space of simulated roughness, has been intriguing and valuable. The similarity sorting situation provides an arena for eliciting both suggestive (although not conclusive) grouping data and highly focussed verbal commentary from subjects.

The current experiment raises questions about the interaction of spatial-period and amplitude factors to produce qualitative perceptual classes of surfaces of interest. Furthermore I would like to

continue to refine the understanding of the possible perceptual status of “bumpiness,” “sharpness,” “smoothness,” “softness,” and other terms used by subjects in this context, as well as the dimension of roughness and texture perceptual space.

In the next chapter, I discuss a program of future research on this and other topics in computational haptics, as well as the conclusions that can be drawn from this stage of the work.

FIGURE 30. Subject progressions: individual 2-,3-,4-group sorts shown from left to right

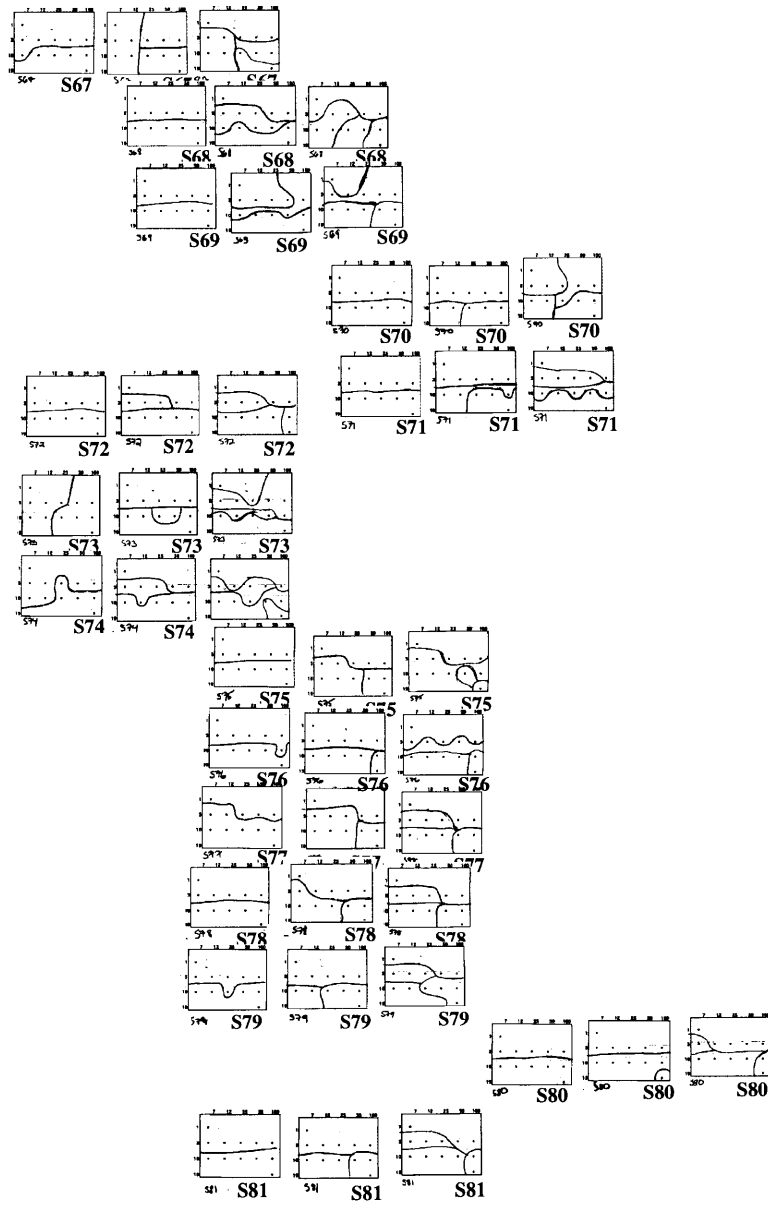

FIGURE 31. Verbal group descriptions for 4-group sorts

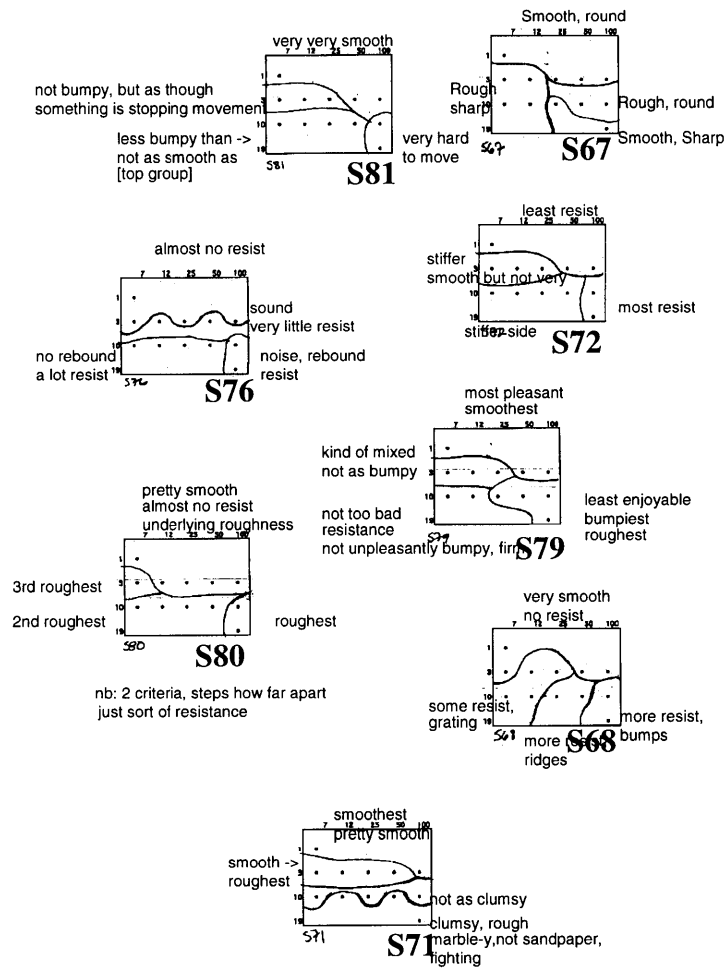
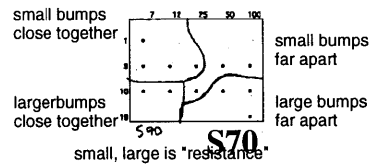
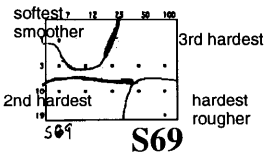
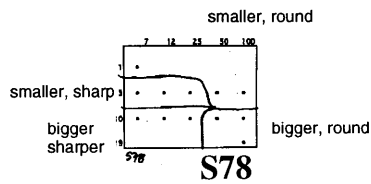
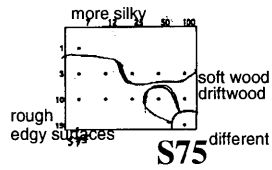
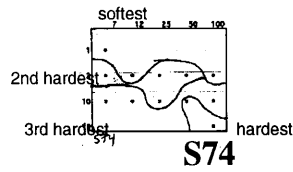
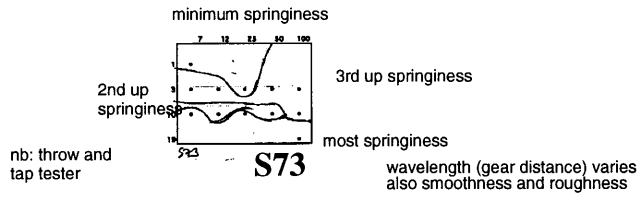

FIGURE 32. Verbal group descriptions con't.



7 Conclusions and Future Work

Conclusions

The work in this thesis provides a novel technique for haptic display of texture and surface features using a 2 degree-of-freedom force-feedback joystick. This provides a pipeline through which any representation of a surface that can be put in the form of a height map can be haptically displayed. The technique is suitable for any force output device with at least 2 degrees of freedom.

I also propose a Material/Perceptual conceptual framework for representing haptically salient aspects of objects, materials, and environments. The framework is intended to be coupled with graphic and sound display in computer environments. Such a rich representation is increasingly necessary for multimedia systems, particularly when the capabilities of the output display are not known in advance.

One level of representation in the proposed framework is a perceptually-based description of the haptic properties of an object. To elaborate briefly, if the haptic nature of a class of objects or materials can be broken down into perceptually separable aspects or percepts, it may be possible to economically assemble haptic displays of a wide variety of these materials by “dialing-in” appropriate physical or computational parameters.

As a first step in this program, I have chosen to attempt this perceptual decomposition and reassembly for a limited domain of materials, specifically textures. Within the realm of texture, I have chosen to deal first with roughness, which is one of the most prominent perceptual aspects of texture:

The new lateral-force display of surface texture proved highly successful. The psychophysical experiment discussed in chapter 4, page 61 shows that people have high confidence that the sensa-

tions produced by my texture classes (grids, gratings, and irregular textures) felt like textured surfaces. Furthermore, descriptions of these surfaces were rich; clearly the nature of the perceptual space spanned by these virtual textures has only begun to be explored.

The display of controlled perceptual roughness of simulated grating textures was also successful: roughness can be scaled across a wide range of amplitude and spatial size. In related experiments discussed in chapter 5, page 89 and chapter 6, page 109, the perceived roughness of grating textures was primarily dependent upon force amplitude despite the fact that subjects were aware of a variety of spatial aspects of the texture simulations.

Thus, for the aspect of perceptual space called roughness, perceptually-based representations can be implemented via a physically-based representation of force-amplitude of a simulated grating texture. However, the fact that verbal reports about the nature of the simulated textures were not in one-to-one correspondence with the psychophysical characterization of roughness highlights the complexity of the space of texture perception.

A study of the multidimensional nature of this texture space is imperative for creating a wide variety of perceptually distinguishable, suggestive, and useful materials.

Future Work

This chapter considers

- improvements and extensions of the planar haptic display of textures used in the dissertation work
- next steps toward creating a wide variety of simulated materials and better understanding the haptic perceptual space for materials
- a discussion of texture mapping, solid texture, and other ways of combining surface and material display with 3D object shape
- a proposal for a broader program of research on computational haptics: general “haptic rendering;”¹ new haptic-display technologies, and hybrid objects

7.1 Creating Additional Lateral-Force Simulated Textures

The lateral-force texture algorithm can be applied to many other digitized or synthesized height fields besides those in this dissertation.

This algorithm has been shown to be a useful haptic representation for surface features. Any image that can be interpreted as a height field can be translated into a “feelable” surface. The images in the Brodatz visual-texture database are representative of naturally occurring textures; thus it would be valuable to see whether the lateral-force version of them also spans a large part of the haptic texture space. Other candidates for providing information in their lateral-force haptic form are height fields derived from natural materials at various scales, for example, electron and scanning micrographs, topographic maps, additional medical imagery, and derived height fields from video and still-camera views of natural scenes.

It would also be worth exploring other synthetic patterns, for example Picard’s synthetic visual textures [Picard92], with the intent of producing controllable aspects of the feel of surface patterns, which may include, for example, roughness, regularity, sharpness, spatial density, and orientation and perhaps also useful haptic simulations of larger features, such as the profiles of small bumps and shapes of shallow features.

7.2 Refined Experiments on the Texture Space of Lateral-Force Textures

To learn more about the perceptual dimensions of lateral-force textures, we need to hone in on the separable dimensions for texture perception. We need to resolve the range of spatial sizes that produce a roughness percept. Our own work and suggestions from the literature prompt us to examine more carefully the differences between feature sizes under 2.5 mm and those over 2.5 mm. The

1. Term coined by Prof. Ken Salisbury, David Brock, and Thomas Massie at the MIT AI Lab

similarity-sorting method in chapter 6, page 109 is a powerful way to elucidate perceptual criteria and we should use it in pilot studies to poke at the space of simulated texture, particularly to understand the role of feature size and shape. It may also be useful to employ a rating method for gathering systematic data on users' classification of our grating stimuli on several scales including "rough-smooth," "sharp-smooth", "flat-bumpy", and "small-large".

Although the lateral-force technique can create a variety of textures, it is important to determine those contexts in which texture is useful as a separable aspect of haptic materials. We further need to determine when we need to add other material properties to our simulations of particular objects or substances. For example, a wide range of materials might be described by a combination of surface texture and variable compliance "beneath" (i.e. normal to) the textured surface.

7.3 Perceptual Dimensions of Texture and Material

One of the most important questions underscored by this thesis research is the need to understand the space of haptic perception, particularly of surface and material properties. One question is whether there is in fact a broad swath of this perceptual space that can be characterized by a small number of descriptive dimensions. The more realistic such a model is, the more we can continue to replace unique *representative-based* descriptions with extensible *perceptually-based* descriptions.

An elegant way to explore the space of materials is to present people with a wide variety, testing whether they span a perceptual space by asking people to make similarity judgements or subdivide the materials into groups by similarity. Cluster analysis or multidimensional-scaling analysis can reveal whether there are plausible dimensions that describe these materials within a perceptual space.

7.3.1 Clustering Experiment to Characterize Haptic Perception Space

What would we include in a clustering experiment in addition to the lateral-force textures used in the experiments in this dissertation?

- higher resolution surface geometry, more small-size textures (feature sizes below 2.5 mm)
- lateral-force texture and normal forces to simulate surface texture, using whatever combination works best.
- compliant surfaces (this requires one more degree of freedom in order to have deformation of the surface in the z-direction)
- sticky surfaces (friction models can be used to simulate surface friction)
- materials with non-elastic deformations
- thermal properties of materials are very important, and thus it is desirable to have haptic displays that allow control of temperature and heat conductivity, along with mechanical properties¹.

7.4 Materials Synthesis

7.4.1 Friction, napped materials, crushables, and non-physical materials

The kind of surface texture we study in detail in this dissertation, which is defined by small variations in the shape of a hard surface, is only part of the story on materials we touch.

Friction: There are several possible models ranging from bulk equations for viscous friction and stiction to microscopic physical models. In fact, modeling texture with very small bumps may create perceived friction for free².

Napped materials: Velvet and fur are examples of materials that have distinctly different properties when stroked in different directions. One could try to model such properties in detail. Just having

1. We list temperature and heat conductivity separately here to emphasize that these physical properties may have different roles in haptic perception. A material's heat conductivity is intrinsic, however its contact temperature may vary according to environmental conditions. Thus simulation of the intrinsic property might lead a user to a conclusion about the nature of the material, control of temperature of the material can lead to conclusions about the environment in which it is sited. In terms of implementation, we can control the haptic display of *both* through rapid control of temperature *alone*.

2. Salisbury et al. recently reported slip detection by users of their simulations of small surface features [Salisbury95].

a striking difference in roughness or slipperiness in different directions of motion might be enough to suggest these materials without a detailed model.

Crushables: Paper crushes when one writes on it with a pen. It crushes less when one sketches lightly with charcoal. This difference is among the haptic cues available to anyone who sketches. Not only does the paper deform under the pen stroke, but surface texture is rubbed smooth during the drawing process. Modeling these properties of paper might make computer drawing come alive, and it might help provide the “feel” of different kinds of drawing media on different kinds of paper. These explorations are analogous to research by David Small [Small91] on the visual interactions of simulated inks with papers.

Non-physical algorithms: In the digital domain, we have the ability to simulate materials that are not based on a strictly physical model. For example, one might make a good-feeling homogeneous rough surface that is *not* based on positionally stable tiny bumps, as in our previous models. Thus, we could also create a “noise” texture on the fly, which simulates small bumps of varying height which are a function of time and hand velocity rather than hand position. So you might not feel the same features as you move over the same spot repeatedly. This might be especially effective for giving an impression of a texture that has no specific localizable features.

7.4.2 Sound

You sometimes hear sounds produced by contact between fingertip (or fingernail) and surface. Little is known about how much information about texture and material properties can be obtained from these sounds.

It would be useful to add digitized or synthesized sounds of fingertip or fingernail upon various surfaces. This suggests the possibility of “superstimuli” combining sound with haptic and graphic display to increase the effectiveness of materials simulations.

Lederman points out that her work [Lederman79] on touch-produced sounds from grating surfaces show that it is not a tremendously successful cue for roughness magnitude. She also notes that Katz [Katz25] found that people can recognize materials effectively from a single tap, where sound is likely to carry a great part of the information.

7.4.3 Solid Textures

Concepts for the haptic display of objects have been dominated by the notion of surface display. That is, some people have thought about displaying both hard and compliant surfaces of complex shapes. A few researchers have thought in detail about richer evocations of surface feel and surface texture. In the area of medical simulation, haptic simulation of volume properties of materials is beginning to be addressed [Singh, Hunter, Gillespie]. We can make volume haptic models which include texture that exists throughout a 3D space. This is suggested by Ken Perlin's notion of *solid textures* for computer graphics [Perlin85]. The irregular Perlin textures we use in this dissertation are actually derived from solid textures and could be used without modification to give, for example, force tangent to motion direction. This may yield a set of materials that do not correspond with everyday haptics; for example, a material that has the complex internal structure of wood and yet can be penetrated easily by the hand. In the real world such a material would be impenetrable and closed to haptic exploration due to the strength and rigidity of its structures.

7.5 Normal-Force Textures and Texture Mapping

7.5.1 Haptic texture mapping: combining material and shape properties

Lateral-force textures could be "texture-mapped" onto contoured surfaces of 3D objects, analogous to texture-mapping techniques in computer graphics [Williams83]. In one simple model of haptic texture mapping, the forces for haptic display of the surface can be added to forces for texture display. Here is one scheme: The surface of an object is defined by a set of polygons or an

analytic surface. The haptic display applies forces appropriate for hard-surface contact in the direction normal to the object surface (at the region of the surface close to the position of the probe attached to the user's hand, finger, or other part of the body.) There are several models for hard surface contact (see section 3.3.2, [Rosenberg93b], and [Colgate89]) that can be used to generate appropriate normal forces. The haptic display applies tangent forces derived from a point in a texture seed patch, which is addressed as though stretched onto the object surface.

7.5.2 Combining lateral- and normal-force textures

In the lateral-force texture technique developed in Chapter 3, I model and calculate the interaction forces between a stylus and the surface only in the lateral directions. A fully three-dimensional model of small features would create forces in an "up" and "down" direction normal to the surface.

There are at least two classes of model that might be useful for producing the normal forces. One is to take the normal component of the force calculated from the local gradient of the surface (as we do for lateral forces in Chapter 3) and add to the contact force with an underlying contoured surface. This is essentially another form of texture mapping. Another method is to model a stylus in contact with the surface at all times, using a local height map that includes all features, to calculate the surface position, and use whatever model of contact with a hard surface is appropriate (for example, stiff spring coupling to the surface).

One could try a one-dimensional version of these strategies with the joystick, by turning it on its side. Iwata [Iwata 1991b] experimented with user recognition of surface contours using a one-dimensional normal-force representation of the surface displayed on a force-feedback device that looks like a telegraph key. His feature sizes are fairly large <greater than 1 mm, check Japanese-language report for this number>.

Plesniak¹ has tried mapping *normal*-force textures onto planes at arbitrary orientations in 3D space. Textures include, sinusoidal gratings, a noise texture, and about 40 Brodatz textures. The surface was modeled as a stiff spring in the region near the (almost planar) surface and displayed with the three degree-of-freedom PHANToM haptic display. Recently, Massie and Salisbury [personal communication] experimented with normal force grating texture and report that lateral-force textures may feel more realistic than pure normal force textures. Shaw [personal communication] has also experimented with combinations of lateral and normal force textures and small features.

Combining lateral and normal forces and conducting a simple experiment to determine their relative effectiveness and whether they enhance one another in creating textures should be investigated next. Hopefully this will be completed by at least one research team in early 1995.

7.6 Representation of Material, Shape, and other Haptic Properties

7.6.1 Combining representations of texture, materials, shape, and other haptic properties

This dissertation concentrates on providing cues about material composition and surface properties of an object rather than about gross shape. I suggest that in certain situations one could considerably improve a virtual environment using an economical haptic display. For example, when I first thought about a haptic display for CAD, I assumed that one needed a glove-form haptic display to allow the designer to handle virtual objects in the same ways as real objects. Now one could imagine a CAD system benefitting as well from a minimal addition of a two degrees-of-freedom haptic display to help the designer select materials and surface finishes for parts whose shapes are viewed primarily visually.

1. personal communication

However, it is also important to design representations of objects so that they can be displayed in high-fidelity haptic environments. In particular, material and surface properties can be combined with display of object shape. The notion of haptic texture mapping in section 7.5.1 is one way of combining surface properties with shape.

This parallels a traditional approach in computer graphics. Object surface shape was represented by a variety of techniques (such as polygonal patches, analytic surfaces). Surface properties such as color, texture, and so forth, were added later.

As in computer graphics, we need to represent important properties of objects that are not easily encompassed by surface models. For example, objects made from highly deformable materials might be best represented through techniques analogous to graphics volume representations.

7.6.2 Graphics interface

Haptics projects with high-performance interfaces to 3D graphics include: [Brooks90, Hirota&Hirose93, Iwata90, Hannaford94, Ouh-young90, Cadoz93 (renders 2D cross sections), Plesniak¹]. Several other projects have high performance 3D graphics interfaces in preparation. Early in this thesis work, a rudimentary interface to Tinsley Galyean's volume graphic display [Galyean91] was tested using a client-server architecture². The joystick host machine generated haptic-display forces while a 3D graphics station maintained the volume display.

7.6.3 Application-driven haptic display from a rich representation

Device dependent rendering has been an important trend in graphics. In the world of haptic displays, this might be analogous to automatically choosing how to display a "rough" surface given

1. Wendy Plesniak and John Underkoffler, At MIT Media Lab, personal communication

2. Client-server system built by S. Drucker and R. O'Connor at the MIT Media Lab.

the availability of different haptic displays. Some devices might be capable of reproducing subtle surface detail. On a simpler, lower-resolution device, one might take advantage of the relationship between perceived roughness and absolute force to vary the force on a large-scale grating patch.

In the past few years, graphics researchers have been integrating knowledge of the user's particular needs for information display with the display pipeline itself. Thus, traditional rendering is being transformed into a set of more subtle choices about drawing, diagramming, or even choosing a lens and cinema shot [Dooley90, Seligman91, Marks91, Salisbury&Salesin94, Drucker95] appropriate to the scene being displayed, the display hardware, and the person looking at it. As information about material composition and haptic properties is integrated into the representation of digital objects, "haptic rendering" will become a more subtle set of choices as well. We will have to ask not only whether we are capable of producing *realistic-feeling* materials, but also whether we can produce sophisticated abstractions such as diagrams, caricatures, and exaggerations in the haptic domain.

7.7 New Displays

7.7.1 Handles

You can get a lot of haptic mileage from attaching various fixed-shape handles to a moveable haptic probe, just as a screwdriver handle and a dessert fork handle aid in very different tasks. In my qualifier paper in Appendix C, I describe the construction of a re-shapeable handle made of foam beads enclosed in a bag with a light vacuum applied to hold any desired shape, I learned this technology from Sean Wellesley-Miller, then a professor of architecture at MIT. Recently this technology has been marketed in the form of three shape-holding devices: a packing bag for shipment of art; and a restraining pillow for patients who must be accurately positioned for medical scanning or radiation procedures; and a shape-changing toy figure, Vac-Man™.

7.7.2 Several fingers together; two hands together

Many haptic displays allow a single probe into a virtual environment; others are highly anthropomorphic, conforming to the degree-of-freedom of the hand. This is an important direction of development for haptic display. An approach complementary to anthropomorphic displays is to use lower-degree-of-freedom devices such as joysticks and PHANToms in quantity in order to create haptic displays suitable for gripping objects between fingers, and manipulating large objects with two hands. An advantage of this approach is reconfigurability, for example, two displays could be used for a thumb and finger then put farther apart for use by two hands.

7.7.3 Two (or more) people together

Communication and cooperation are what we spend most of our time doing, the same should be true of environments mediated by computation. Displays that allow people to experience some of the qualities of touching each other, and of working together to handle and experience external objects, are essential. Rudimentary versions of these environments can be built by allowing multiple users of current haptic-display devices to interact in the same simulated environment. It is hoped that increasingly abstracted representation of haptic objects and environments will aid in solving the problems of delay and bandwidth limitations in remote, networked haptic communication display.

7.7.4 Display to other parts of the body

Hands have been the focus of most haptics research because there is no question that they have the highest density of tactile sensors, and because they are used for most haptic “information work”. For entertainment, immersion in large-scale environments, and combining sensory modes, we

need to make haptic interfaces tuned to the whole body and to the larger-scale movements associated with sports, dance, playing music, swimming, ambling, etc.

Pneumatic technology has many limitations, but could be particularly appropriate for providing full-body haptic feedback. I envision a body suit constructed like a complex flight suit, with separate bladders for sequencing force application along the limbs and torso of the body.

7.7.5 Hybrid Objects: Combining Real and Simulated Haptics

Control of force-feedback devices is a “general purpose” approach to haptics. A single robotic or pneumatic display device is the locus of all haptic interaction, and it tries to simulate as many haptic phenomena as possible. In any haptic display device, there are haptic properties that can be altered by the computer, those that can be altered by the user, and those that are inherent in the construction of the device and cannot be altered at all. In haptic display projects so far, the inherent properties of the device are usually disadvantageous for all purposes: when unplugged they can’t tighten a screw, don’t hold water, and are not even beautiful. Thus, an effort is made to make the devices disappear into the external environment; their shape, appearance, and inherent haptic properties are downplayed so that the user attends only to the simulated haptic environment.

Another approach is to seek “special purpose” haptic displays, which although less protean, may have more useful inherent physical affordances. Thus, we view a new kind of haptic display as a *hybrid* of the inherent haptic properties of a useful object and its limited computationally controllable haptic properties. A limited ability to change shape could go a long way. A single handful of stuff could become a telephone, a bowl, a sculpture. One can imagine applications in which ability to change texture or elasticity, only one haptic property at a time, might also be useful and entertaining.

The customizable styrofoam tool handle from my doctoral qualifier paper in Appendix C is an example of a real object with a starting shape and hardness which can be sculpted and then locked into a new shape (it starts as a floppy bag of foam bits; it can become a bean bag chair or a toy octopus.) As a display, this has only one computationally controllable haptic bit: whether to be floppy or rigid. It has a lot more user controllable haptic freedom (its shape), and perhaps a computing environment could learn of its new shape through a smart vision system. Certainly, there are many haptic properties that simply cannot be altered easily in this hybrid object, such as the light weight and crunchiness of styrofoam.

Another hybrid prototype concept is a shape changing device made from a sphere (or other starting shape) of closed-cell neoprene foam. An array of small pneumatic needles is inserted into the foam, the needles form a 3D array by carrying the insertion distance. By filling and evacuating individual cells in the foam with air from the needles, the sphere can be expanded or sculpted into a range of shapes. A closed-cell foam shape-changer would have more bits of digital controllability than the styrofoam bead device, yet less than the force-feedback joystick. Unlike a joystick, or other force-feedback “haptic workstation”, it has the satisfying and useful properties of being a handheld, portable object.

7.8 Sample Applications for Haptic Display

Now that there is a way to display small surface features and textures, it is time to integrate this technique into an application. Despite the fact that the space of simulated haptic texture has not been completely characterized through psychophysical investigation, it is important to continue to build systems and learn about haptic materials synthesis through observation of users in more complex, exploratory environments that are of direct use to the participants.

Consider the following scenarios:

Designing consumer products: Haptic properties of consumer products matter; they touch the body or are held in the hand. A designer at a haptic CAD station could feel the product she is designing. If the haptic properties of the product are realistic, it may speed up prototyping by eliminating model-making phases of design. It may also affect the design process in deeper ways, by bringing more of the skills of craftsmanship and modelmaking to the forefront of the design process. Thus, it may open up more alternatives in the designer's mind for choices of materials, interaction style, and manufacture of a product.

Sewing and textile workstation. This is my own hobby. Home sewing is one of many design and construction activities that are popular pursuits in the home. People who sew at home often use swatch services to select fabrics. Once they have fabric, they have very few tools for previewing how a garment will look and feel. A design preview program could offer to let you feel fabrics, based on a representation of salient haptic perceptual aspects of fabrics, as well as see simulations of how they drape in clothing designs. This would be useful for honing in on intended fit and appearance, and it also would appeal to the desire to develop more designs than one person can actually make.

Enhancing the desktop metaphor. Desktop metaphor interfaces are a popular interface between the digital domain and the physical world, however they are impoverished in the kinds of physical cues they can offer and recognize. Haptic interaction could provide another channel of interaction with the desktop. For example, icons, menu items, and documents could have detents so that they are easy to find while visual attention is elsewhere (as in Mgrav in section 3.2.2) Changeable information could be displayed haptically, for example, documents could have deep detents if they have been edited recently, pulling your hand toward your current work. Different textures could be used on regions of the screen with different kinds of content.

Sorting visual information. Imagine an application for sorting digitized slides for presentations. When sorting images, one often has many parallel criteria for judging and sorting, yet few ways to organize the imagery while in the process of sorting. Imagine a display on which you can lay out all the imagery at once. With a haptic interface, one could enhance the visual information in the slide's content by adding degrees of roughness for how important the slide is to the story being told, and more friction between the slide and virtual surface, according to how sure one is of the slide's position in the presentation. You could quickly review that information as you try to move a slide or as you scan your hand across the display surface.

Letting kids create their own physics. In a constructionist learning culture such as that which surrounds the Logo computing environment, kids use open-ended programming tools in which they can construct powerful abstractions with concrete manifestations. The physical haptic primitives that we use, such as textbook objects and surface textures, could be available as building blocks in a Logo microworld, for kids to construct their own materials and objects for haptic display. Kids could experiment with computational models of perceptual and physical models of textures, materials and systems of physical objects, and experience some of the same excitement we have found when a computational model creates real materials that you can feel.

References

This bibliography is also available at

<http://marg.www.media.mit.edu/people/marg/haptics-bibliography.html>

<http://www.minsky.org/marg/haptics-bibliography.html>

Key to annotations:

C item is cited in thesis text

T item is a source for Table of Haptics Interaction Projects in Chapter 2

Adelstein, B. D., & Rosen, M. J. (1987). A Two-Degree-of-Freedom Loading Manipulandum for the Study of Human Arm Dynamics. In *ASME Winter Annual Meeting 1987*, pp. 111-112, Boston, Massachusetts **T**

Adelstein, B. D., & Rosen, M. J. (1990). A High Performance Two Degree-of-Freedom Kinesthetic Interface. In N. Durlach (Ed.), *Proceedings of the Engineering Foundation Conference on Human Machine Interfaces for Teleoperators and Virtual Environments*, Santa Barbara, CA **T**

Adelstein, B. D., & Rosen, M. J. (1992). Design and Implementation of a Force Reflecting Manipulandum for Manual Control Research. In *ASME Winter Annual Meeting 1992*, Anaheim, CA

Andrews, J. R., & Hogan, N. (1983). Impedance Control as a Framework for Implementing Obstacle Avoidance in a Manipulator. In D. E. Hardt & W. J. Book (Eds.), *AMSE Winter Meeting 1983*, pp. 243-251, Boston, MA

ARTBEATS (1994). *Wood & Paper Texture Clip Art Advertisement*. ARTBEATS, Myrtle Creek, OR

Atkinson, W. D., Bond, K. E., Tribble, G. L., III, & Wilson, K. R. (1977). Computing with Feeling, *Comput. & Graphics*, 2, pp. 97-103 **T**

ATR (1989). *ATR Communication Systems Artificial Intelligence Department 1989 Annual Report* (Brochure/Research Summary). Advanced Telecommunications Research Institute International, Japan

-
- Bajcsy, R., Lederman, S., & Klatzky, R. (1989). *Machine systems for exploration and manipulation: A conceptual framework and method of evaluation* Dept. of Computing Science Technical Report MS-CIS-89-03, GRASP LAB 172). University of Pennsylvania
- Balakrishnan, J. D., Klatzky, R. L., & Loomis, J. M. (1989). Length distortion of temporally extended visual displays: Similarity to haptic spatial perception, *Perception & Psychophysics*, 46(4), pp. 387-394
- Barber, P. O., & Lederman, S. J. (1988). Encoding Direction in Manipulatory Space and the Role of Visual Experience, *Journal of Visual Impairment and Blindness*, pp. 99-105
- Batter, J. J., & Brooks, F. P., Jr. (1971). Grope-1: A computer display to the sense of feel. In *Information Processing, Proceedings of IFIP Congress 71*, pp. 759-763, C T
- Bejczy, A. K. (1992). Teleoperation: The Language of the Human Hand. In *Proceedings of the 1992 IEEE Workshop on Robot and Human Communication*, pp. 32-43, Tokyo, Japan
- Bergamasco, M. (1992). Design of Hand Force Feedback Systems for Glove-like Advanced Interfaces. In *Proceedings of the 1992 IEEE Workshop on Robot and Human Communication*, pp. 286-293, Tokyo, Japan
- Bishop, G., Bricken, W., Brooks, F., Jr., Brown, M., Burbeck, C., Durlach, N., Ellis, S., Fuchs, H., Green, M., Lackner, J., McNeill, M., Moshell, M., Pausch, R., Robinett, W., Srinivasan, M., Sutherland, I., Urban, D., & Wenzel, E. (1992). Research Directions in Virtual Environments: Report of an NSF Invitational Workshop March 1992, UNC-CH, *Computer Graphics*, 26(3), pp. 154-177
- Blattner, M. (Ed.) (1992). *Computer Mediated Interaction*. ACM Press
- Bliss, J. C., Hill, J. W., & Wilber, B. M. (1971). *Tactile Perception Studies Related to Teleoperator Systems* (Contractor Report NASA CR-1775). SRI for NASA
- Bolanowski, S. J. J., Gescheider, G. A., Verrillo, R. T., & Checkosky, C. M. (1988). Four channels mediate the mechanical aspects of touch, *The Journal of the Acoustical Society of America*, pp. 1680-1694
- Bolt, R. A. (1982). *I. Virtual manual-graphical space; II: Tactual Simulation* (Concept Paper). MIT Architecture Machine Group C T
- Brodatz, P. (1966). *Textures*. New York: Dover C

-
- Brodey, W. (1987). *Teletouch™ and Bionics A/S* (Press Kit). Bionics A/S T
- Brooks, F. P., Jr. (1977). The Computer "Scientist" as Toolsmith - Studies in Interactive Computer Graphics. In B. Gilchrist (Ed.), *Information Processing, Proceedings of the IFIP Congress 1977*, pp. 625-634, C
- Brooks, F. P., Jr. (1988). Grasping Reality Through Illusion - Interactive Graphics Serving Science. In *Fifth Conference on Computers and Human Interaction, CHI '88 Proceedings*, pp. 1-11, Washington, DC C
- Brooks, F. P., Jr., Ouh-Young, M., Batter, J. J., & Kilpatrick, P. J. (1990). Project GROPE - Haptic Displays for Scientific Visualization. In *Computer Graphics, Proceedings of SIGGRAPH'90*, Vol. 24, Boston, MA C
- Brooks, T. L., & Bejczy, A. K. (1986). *Survey of Hand Controllers for Teleoperation* (NASA TECH BRIEF Vol 10, No 1, Item #88). NASA JPL
- Brown, J. M., & Colgate, J. E. (1994). Physics-Based Approach to Haptic Display. In *Proceedings of ISMCR 94, Topical Workshop on Virtual Reality*, Houston, TX
- Browne, M. W. (1993, Tuesday, May 25, 1993). *With Ivory in Short Supply, Pianists Tickle the Polymers*. New York Times, p. C1, C8
- Burdea, G., & Zhuang, J. (1991). Dextrous telerobotics with force feedback - an overview. Part 1: Human factors, *Robotica*, 9, pp. 171-178 T
- Burdea, G., & Zhuang, J. (1991). Dextrous telerobotics with force feedback - an overview. Part 2: Control and implementation, *Robotica*, 9, pp. 171-178 T
- Burdea, G., Zhuang, J., Roskos, E., Silver, D., & Langrana, N. (1991). A Portable Dextrous Master With Force Feedback, *Presence*, June T
- Buttolo, P., Braathen, P., & Hannaford, B. (1994). Sliding Control of Force Reflecting Teleoperation: Preliminary Studies, *Presence*
- Buxton, W., & Meyers, B. (1986). A study of 2-handed input. In *Proceedings of CHI'86*,
- Cadoz, C., Lisowski, L., & Florens, J.-L. (1990). Modular Feedback Keyboard, *Computer Music Journal*, 14(2), pp. 47-51 C T

Cadoz, C., Luciani, A., & Florens, J.-L. (1993). CORDIS-ANIMA: A modeling and simulation System for Sound and Image Synthesis - The General Formalism, *Computer Music Journal*, 17(1), pp. 19-29 C T

Carterette, E. C., & Friedman, M. P. (1973). *Handbook of Perception*. Los Angeles: Academic Press

Cherubino, C. (1988). *Tactile Simulation: Exploration and Application*. Bachelor of Science, Massachusetts Institute of Technology

Clark, F. J., & Horch, K. W. (1986). "Kinesthesia", In K. Boff, L. Kaufman, & J. Thomas (Eds.), *Handbook of Perception and Human Performance* (pp. 13-1,13-62), New York: Wiley C

Colgate, E., & Hogan, N. (1989). An Analysis of Contact Instability in Terms of Passive Physical Equivalents. In *Proceedings on the IEEE Robotics and Automation Conference 89*, pp. 404-409, Scottsdale, AZ C

Colgate, J. E. (1993). *Robust Impedance Shaping Telemanipulation*. Dept. of Mech. E., Northwestern University

Colgate, J. E., & Brown, J. M. (1994). Factors Affecting the Z-Width of a Haptic Interface. In *Proceedings of the 1994 IEEE International Conference on Robotics and Automation*, pp. 3205-3210,

Colgate, J. E., Grafing, P. E., Stanley, M. C., & Schenkel, G. (1993). Implementation of Stiff Virtual Walls in Force-Reflecting Interfaces. In *VRAIS '93*, pp. 202-208, Seattle, WA

Colgate, J. E., & Hogan, N. (1988). Robust control of dynamically interacting systems, *Int. Journal Control*, 48(1), pp. 65-88

Colgate, J. E., & Schenkel, G. G. (1994). Passivity of a Class of Sampled-Data Systems: Application to Haptic Interfaces. In *Proceedings of the American Control Conference*,

Craig, J. C., & Sherrick, C. E. (1969). The role of skin coupling in the determination of vibrotactile spatial summation, *Perception & Psychophysics*, 6(2), pp. 97-101

Cussler, E. L., Zlotnick, S. J., & Shaw, M. C. (1977). Texture perceived with the fingers, *Perception & Psychophysics*, 21(6), pp. 504-512

-
- Cutkowsky, M. R., & Howe, R. D. (1993). Dynamic Tactile Sensing, *IEEE Transactions on Robotics and Automation*, 9(2), pp. 140-151
- Cutt, P. S. (1991). *Tactile Feedback Technology* (Report on company's memory metal tactile array; brochure). TiNi Alloy Company, Oakland, CA
- Darian-Smith, I., Davidson, I., & Johnson, K. O. (1980). Peripheral Neural Representation of Spatial Dimensions of a Textured Surface Moving Across the Monkey's Finger Pad, *J. Physiol.*, 309, pp. 135-146
- Darian-Smith, I., & Kenins, P. (1980). Innervation Density of Mechanoreceptive Fibres Supplying Glabrous Skin of the Monkey's Index Finger, *Journal Physiology*, (309), pp. 147-155
- Darian-Smith, I., & Oke, L. E. (1980). Peripheral Neural Representation of the Spatial Frequency of a Grating Moving Across the Monkey's Finger Pad, *J. Physiol.*, 309, pp. 117-136
- Dario, A., Rossi, D. D., Domenici, C., & Francesconi, R. (1984). Ferroelectric Polymer Tactile Sensors With Anthropomorphic Features, *IEEE Robotics and Automation?*, pp. 332-340
- Dellon, A. L. (1981). *Evaluation of Sensibility and Re-education of Sensation in the Hand*. Baltimore: Williams & Wilkins
- Donaldson, H. H. (1885). On the Temperature Sense, *MIND*, 10, pp. 399-416
- Dooley, D., & Cohen, M. (1990). Automatic Illustration of 3D Geometric Models: Lines. In *Computer Graphics, Proceedings of SIGGRAPH1990 Symposium on 3D Interactive Graphics*, Vol. 24, pp. 77-82, Snowbird, UT C
- Drucker, S. M. (1989). "Texture from Touch", In W. Richards (Ed.), *Natural Computation*, Cambridge, MA: MIT Press C
- Drucker, S. M., & Zeltzer, D. (1995). CamDroid: A System for Implementing Intelligent Camera Control. In *ACM 1995 Symposium on Interactive 3D Graphics*, Monterey, CA C
- Durlach, N. (Ed.) (1990). *Human-Machine Interfaces for Teleoperators & Virtual Environments (Abstracts)*. Santa Barbara: Engineering Foundation

Durlach, N. I., Delhorne, L. A., Wong, A., Ko, W. Y., Rabinowitz, W. M., & Hollerbach, J. (1989). Manual discrimination and identification of length by the finger-span method, *Perception & Psychophysics*, 46(1), pp. 29-38

Eberhardt, S. P., Bernstein, L. E., Coulter, D. C., & Hunckler, L. A. (1993). OMAR - A haptic display for speech perception by deaf and deaf-blind individuals. In *VRAIS - 83*, pp. 195-201, Seattle

Edin, B. B., Howe, R. D., Westling, G., & Cutkosky, M. R. Relaying frictional information to a human teleoperator by physiological mechanisms, *IEEE Transactions on System, Man, and Cybernetics*, 23(2), pp. 427-432

Engel, F., Haakma, R., & van Itegem, J. (1991). *Trackball with Contextual Motor Feedback* (Brochure, color). Institute for Perception Research, Eindhoven, The Netherlands

Evarts, E. V. (1974). "Sensorimotor Cortex Activity Associated with Movements Triggered by Visual as Compared to Somesthetic Inputs", In F. O. Schmitt (Ed.), *The Neurosciences: third study program* (pp. 327-337), Cambridge: MIT Press

EXOS, I. (1995). "*The Force*" (Brochure/Press Kit). Exos, Inc., Woburn, MA T

Foley, J. D. (1987) *Interfaces for Advanced Computing*. Scientific American, p. 127-135 C

Fujisawa, Y., Fukuda, T., Kosuge, K., Arai, F., Muro, E., Hoshino, H., Miyazaki, T., Ohtsubo, K., & Uehara, K. (1992). Control of Manipulator/Vehicle System for Man-Robot Cooperation Based on Human Intention. In *IEEE Workshop on Robot & Human Communication*, pp. 188-193, Tokyo, Japan

Fukui, Y., & Shimojo, M. (1992). Difference in Recognition of Optical Illusion Using Visual and Tactual Sense, *Journal of Robotics and Mechatronics*, 4(1), pp. 58-62

Galyean, T., & Hughes, J. F. (1991). Sculpting: An Interactive Volumetric Modeling Technique. In *Computer Graphics, Proceedings of SIGGRAPH'91*, Vol. 25, pp. 267-274, C

Gardner, E. P., & Palmer, C. I. (1989). Simulation of Motion on the Skin. I. Receptive Fields and Temporal Frequency Coding by Cutaneous Mechanoreceptors of OPTACON Pulses Delivered to the Hand, *Journal of Neurophysiology*, 62(6), pp. 1410-1436

-
- Gardner, E. P., & Palmer, C. I. (1989). Simulation of Motion on the Skin. II. Cutaneous Mechanoreceptor Coding of the Width and Texture of Bar Patterns Displayed Across the OPTACON, *Journal of Neurophysiology*, 62(6), pp. 1437-1460
- Garner, H. D. (1994). *Reconfigurable Full-Page Braille Displays* (NASA Tech Brief). NASA Langley Research Center
- Garner, W. R. (1976). Interaction of Stimulus Dimensions in Concept and Choice Processes, *Cognitive Psychology*, 8, pp. 98-123 C
- GEScale (c. 1960). *Roughness Scales 342X60 and 342X61*. General Electric Corporation C
- Gibson, J. J. (1962). Observations on active touch, *Psychological Review*, 69, pp. 477-490 C
- Gillespie, B. (1992). Dynamical Modeling of the Grand Piano Action. In *International Computer Music Conference (ICMC) Proceedings*, pp. 77-80, San Jose, CA T
- Gillespie, B. (1992). The Touchback Keyboard. In *International Computer Music Conference (ICMC) Proceedings*, pp. 447-448, San Jose, CA T
- Gillespie, B. (1993). The Virtual Piano Action: Design and Implementation. In *International Computer Music Conference (ICMC) Proceedings*, Aarhus, Denmark T
- Gillespie, B., & Cutkowsky, M. (1993). Interactive Dynamics with Haptic Display. In *Proceedings of 1993 ASME Winter Annual Meeting*, Vol. DSC-Vol 49, pp. 65-72, New Orleans, LA
- Gillespie, B., & O'Modhrain, S. (1994). *A Haptic User Interface: Computer Access for the Blind*. CCRMA Internal Report, Stanford University
- Gillespie, B., & Rosenberg, L. (1994). Design of High-Fidelity Haptic Display for One-Dimensional Force Reflection Applications. In *Proceedings of the SPIE East Coast Conference*, Boston, MA C
- Goodwin, A. W., & John, K. T. (1988). "Tactile Perception of Texture: Peripheral Neural Correlates", In M. Rowe & L. Aitkin (Eds.), *Information Processing in the Mammalian Auditory and Tactile Systems*, Alan R. Liss

Goodwin, A. W., John, K. T., Sathian, K., & Darian-Smith, I. (1989). Spatial and Temporal Factors Determining Afferent Fiber Response to a Grating Moving Sinusoidally Over the Monkey's Fingerpad, *The Journal of Neuroscience*, 9(4), pp. 1280-1293

Goodwin, A. W., & Morley, J. W. (1987). Sinusoidal Movement of a Grating Across the Monkey's Fingerpad: Effect of Contact Angle and Force of the Grating on Afferent Fiber Responses, *The Journal of Neuroscience*, 7(7), pp. 2192-2202

Goodwin, A. W., & Morley, J. W. (1987). Sinusoidal Movement of a Grating Across the Monkey's Fingerpad: Representation of Grating and Movement Features in Afferent Fiber Responses, *The Journal of Neuroscience*, 7(7), pp. 2168-2180

Green, B. G. (1977). The effect of skin temperature on vibrotactile sensitivity, *Perception & Psychophysics*, 21(3), pp. 243-248

Green, B. G., Lederman, S. J., & Stevens, J. C. (1979). The Effect of Skin Temperature on the Perception of Roughness, *Sensory Processes*, 3, pp. 327-333

Hajian, A. Z., & Howe, R. D. (1994). Identification of the mechanical impedance of human fingers. In *Symposium on Haptic Interfaces, ASME 1994 Winter Annual Meeting*, Chicago, IL

Hannaford, B. (1989). A Design Framework for Teleoperators with Kinesthetic Feedback, *IEEE Transactions on Robotics and Automation*, 5(4)

Hannaford, B. (1989). Stability and Performance Tradeoffs in Bi-Lateral Telem Manipulation. In *International Conference on Robotics and Automation*, Vol. 3, pp. 1764-1767, Scottsdale, Arizona

Hannaford, B. (1994) **WWW Page** <http://isdl.ee.washington.edu/BRL/pages/biorobotics.html>

Hannaford, B., Marbot, P. H., Moreyra, M., & Venema, S. (1994). A 5-Axis Mini Direct Drive Robot for Time Delayed Teleoperation. In *Proc. Intelligent Robots and Systems (IROS 94)*, Munich, Germany

Hannaford, B., & Venema, S. (1993). "Kinesthetic Feedback in Virtual Environments and Teleoperation", In W. Barfield (Ed.), *Handbook of Human Factors in Virtual Environments*, T

Hardt, D. E., & Book, W. J. (1983). Control of Manufacturing Processes and Robotic Systems, *American Society of Mechanical Engineers*, pp. 243-251

-
- Hashimoto, H., & Buss, M. (1992). Analysis and Synthesis of Human Skill for the Intelligent Assisting System. In *IEEE International Workshop on Robot and Human Communication*, pp. 177-182, Tokyo, Japan
- Hashimoto, H., Kunii, Y., Buss, M., & Harashima, F. (1993). Dynamic Force Stimulator for Feedback Human-Machine Interaction. In *VRAIS*, pp. 209-215, Seattle
- Hecker, R., & Perlin, K. (1994). Tactile Widgets at Consumer Prices. In *Computer Graphics (SIG-GRAPH '94)*, Orlando, FL
- Hirose, M. (1993). Visualization Tool Applications of Artificial Reality. In *The 3rd International Conference on Artificial Reality and Tele-Existence: ICAT '93*, Tokyo
- Hirota, K., & Hirose, M. (1993). Development of Surface Display. In *VRAIS'93*, Seattle, WA C T
- Hirota, K., & Hirose, M. (1994). Simulation and Presentation of Curved Surface in Virtual Reality Environment Through Surface Display. In *VRAIS'95*, Research Triangle Park, NC T
- Hogan, N. (1984). Impedance Control of Industrial Robots, *Robotics & Computer Integrated Manufacturing*, 1(1), pp. 97-113
- Hogan, N. (1984). Some Computational Problems Simplified by Impedance Control. In *ASME Computers*, pp. 203-209, Las Vegas
- Hogan, N. (1985). Impedance Control: An approach to Manipulation: Part 1 - Theory, *Journal of Dynamic Systems, Measurement, and Control*, 107, pp. 1-7 C
- Hogan, N. (1985). Impedance Control: An Approach to Manipulation: Part II - Implementation, *Journal of Dynamic Systems, Measurement, and Control*, 107, pp. 8-24 C
- Hogan, N. (1985). Impedance Control: An Approach to Manipulation: Part III - Applications, *Journal of Dynamic Systems, Measurement, and Control*, 107, pp. 17-24 C
- Hogan, N. (1986). "Impedance Control Applied to Automated Deburring", In K. S. Narendra (Ed.), *Adaptive and Learning Systems* (pp. 359-366), Plenum
- Hogan, N. (1987). Beyond Regulators: Modelling Control Systems as Physical Systems. In *American Control Conference*, Minneapolis

-
- Hogan, N. (1987). Stable Execution of Contact Tasks Using Impedance Control. In *Proceedings of the IEEE International Conference of Robotics and Automation*, pp. 1047-1054, Raleigh, NC
- Hogan, N. (1988). On the Stability of Manipulators Performing Contact Tasks, *IEEE*, 4(6), pp. 677-686
- Hogan, N. (1989). Controlling Impedance at the Man/Machine Interface. In *Proceedings of the 1989 IEEE International Conference on Robotics and Automation*, pp. 1626-1631, Scottsdale, AZ
- Hogan, N. (1990). "Control of Contact in Robots and Biological Systems", In Dario (Ed.), *Robots and Biological Systems*, Springer-Verlag C
- Hogan, N. (1990). "Mechanical Impedance of Single- and Multi-Articular Systems", In J. Winters & S. Woo (Eds.), *Multiple Muscle Systems: Biomechanics and Movement Organization* (pp. 1-23), Massachusetts: Springer-Verlag
- Hogan, N., & Cotter, S. L. (1982). "Cartesian Impedance Control of a Nonlinear Manipulator", In W. J. Book (Ed.), *Robotics Research and Advanced Applications* (pp. 121-128), New York: American Society of Mechanical Engineers
- Hogan, N., Kay, B. A., Fasse, E. D., & Mussa-Ivaldi, F. A. (1990). Haptic Illusions: Experiments on Human Manipulation and Perception of "Virtual Objects", *Cold Spring Harbor Symposia on Quantitative Biology*, LV, pp. 925-931
- Hogan, N., Krebs, H. I., Charnnarong, J., Srikrishna, P., & Sharon, A. (1992). MIT-MANUS: A Workstation for Manual Therapy and Training I. In *Proc. IEEE Workshop on Robot and Human Communication*, pp. 161-165, Tokyo, Japan
- Hollins, M., Faldowski, R., Rao, S., & Young, F. (1993). Perceptual dimensions of tactile surface texture: A multidimensional scaling analysis, *Perception and Psychophysics*, 54(6), pp. 697-705
C
- Howe, R. D. (1992). A Force-Reflecting Teleoperated Hand System for the Study of Tactile Sensing in Precision Manipulation. In *Proceedings of the 1992 IEEE International Conference on Robotics and Automation*, Vol. 2, pp. 1321-1326, Nice, France
- Howe, R. D. (1994). Tactile sensing and control of robotic manipulation, *Journal of Advanced Robotics*, 8(3), pp. 245-261 T

-
- Howe, R. D., & Cutkosky, M. R. (1989). Sensing Skin Acceleration for Slip and Texture Perception. In *Proceedings of the 1989 IEEE Conference on Robotics and Automation*, Scottsdale, AZ
- Howe, R. D., & Cutkosky, M. R. (1993). Dynamic tactile sensing: Perception of fine surface features with stress rate sensing, *IEEE Transactions on Robotics and Automation*, 9(2), pp. 140-151
- Howe, R. D., & Kontarinis, D. (1992). Task performance with a dextrous teleoperated hand system. In *Telem manipulator Technology Conference*, pp. 199-207, Boston, MA
- Howe, R. D., Peine, W. J., Kontarinis, D. A., & Son, J. S. (1995). Remote palpation technology for surgical applications, *IEEE Engineering in Medicine and Biology Magazine*
- Howe, R. D., Popp, N., Kao, I., Akella, P., & Cutkosky, M. (1990). Grasping, Manipulation, and Control with Tactile Sensing. In *Proceedings of the 1990 IEEE International Conference on Robotics and Automation*, Cincinnati, OH
- Hunter, I. W., Lafontaine, S., Nielsen, P. M. F., Hunter, P. J., & Hollerbach, J. M. (1989). Manipulation and Dynamic Mechanical Testing of Microscopic Objects Using a Tele-Micro-Robot System, *IEEE*, pp. 1553-1558
- Ino, S., Shimizu, S., Hosoe, H., Izumi, T., Takahashi, M., & Ifukube, T. (1992). A Basic Study on the Tactile Display for Tele-presence. In *Proc. IEEE Workshop on Robot and Human Communication*, pp. 58-62, Tokyo, Japan
- Interlink (1988). *Force Sensing Resistor Technology* (Interlink Product Brochure). Interlink Electronics Corp.
- Ish-Shalom, J. (1988). *Experimental Results of using a Step Motor as a Programmable Spring RC 14024 (#62875)*. IBM Research Division
- Ishii, M., & Sato, M. (1993). A 3D Interface Device with Force Feedback: A Virtual Work Space for Pick-and-Place Tasks. In IEEE (Ed.), *VRAIS '93*, pp. 331-335, Seattle T
- Iwata, H. (1990). Artificial Reality with Force-Feedback: Development of Desktop Virtual Space with Compact Master Manipulator, *Computer Graphics, Proceedings of Siggraph '90*, 24(4) C T
- Iwata, H. (1992). Force Display for Virtual Worlds. In *Proc. of International Symposium of Artificial Reality and Tele-existence*, C T

Iwata, H. (1993). Pen-based Haptic Virtual Environment. In *VRAIS '93*, pp. 287-292, Seattle, WA
C T

Iwata, H., & Hiroaki, Y. (1994). Desktop Force Display. In *Invited Interactive Demonstration, in The Edge, at Siggraph '94*, Orlando, FL T

Iwata, H., Nakagawa, T., & Nakashima, T. (1991). Force Display for Presentation of Rigidity of Virtual Objects. In *7th Symposium on Human Interface*, Vol. October, pp. 55-58, Kyoto C T

Iwata, H., Nakagawa, T., & Yano, H. (1992). Development of a Force Display for Large Working Volume, *Human Interface News and Report*, 7, pp. 243-250 C T

Iwata, H., & Noma, H. (1993). *Volume Haptization*. Institute of Engineering Mechanics, University of Tsukuba

Iwata, H., Noma, H., & Nakashima, T. (1991). Performance Evaluation of Recognition and Manipulation of Virtual Objects by Force Display, *Human Interface - News and Report*, 6, pp. 114-121 C T

Iwata, H., & Yano, H. (1993). Artificial Life in Haptic Virtual Environment. In *The 3rd International Conference on Artificial Reality and Tele-Existence: ICAT '93*, Tokyo

Jacobsen, S. C., Iversen, E. K., Davis, C. C., Potter, D. M., & McLain, T. W. (1989). Design of a multiple-degree-of-freedom, force-reflective hand master/slave with a high mobility wrist. In *Proceedings of ANS/IEEE/SMC 3rd Topical Meeting on Robotics and Remote Systems*, Charleston, SC T

Jex, H. (1988). Four critical tests for control feel simulators. In *Proceedings of 1988 Annual Conference on Manual Control*, Cambridge, MA: MIT C

Johansson, R. S., & Vallbo, A. B. (1983). Tactile sensory coding in the glabrous skin of the human hand, *Trends in NeuroSciences*, 6(1), pp. 27-32

Johnson, A. R. (1977). Telegrasping at Midnight 'Neath the Starry Sky, *Mind*, July, pp. 15-18

Johnson, K. O. (1983). Neural mechanisms of tactual form and texture discrimination. In *The American Physiological Society at the Sixty-Sixth Annual Meeting of the Federation of American Societies for Experimental Biology*, Vol. 42(9), pp. 2542-2547, New Orleans

Johnson, K. O., & Lamb, G. D. (1981). Neural Mechanisms of Spatial Tactile Discrimination: Neural Patterns Evoked by Braille-Like Dot Patterns in the Monkey, *J. Physiol.*, 310, pp. 177-144

Johnson, K. O., & Phillips, J. R. (1981). Tactile Spatial Resolution. I. Two-Point Discrimination, Gap Detection, Grating Resolution, and Letter Recognition, *Journal of Neurophysiology*, 46(6), pp. 1177-1191

Johnson, K. O., Phillips, J. R., & Freeman, A. W. (1985). "Mechanisms Underlying the Spatiotemporal Response Properties of Cutaneous Mechanoreceptive Afferents", In *Development, Organization, and Processing in Somatosensory Pathways* (pp. 111-122), Alan R. Liss, Inc.

Kaczmarek, K. A., Webster, J. G., Bach-y-Rita, P., & Tompkins, W. J. (1991). Electrotactile and Vibrotactile Displays for Sensory Substitution Systems, *IEEE Transactions on Biomedical Engineering*, 38(1), pp. 1-16

Kameyama, K., Ohtomi, K., & Fukui, Y. (1992). A Virtual Reality System Using a Volume Scanning 3D Display. In *The Second International Conference on Artificial and Tele-existence ICAT'92*, pp. 49-62, Tokyo, Japan

Katz, D. (1989). *The World of Touch, written 1925* (Lester E. Krueger, Trans.) Lawrence Erlbaum Associates C

Kilpatrick, P. J. (1976). *The Use of a Kinesthetic Supplement in an Interactive Graphics System*. Ph.D. dissertation, Computer Science, University of North Carolina at Chapel Hill C T

Kim, I., & Inooka, H. (1992). Hand-over of an Object between Human and Robot. In *IEEE International Workshop of Robot and Human Communication*,

Klatzky, R. L. (1987). The Intelligent Hand, *The Psychology of Learning*, 21, pp. 121-149

Klatzky, R. L., & Lederman, S. (1988). Intelligent Exploration of the Human Hand, *IEEE*, pp. 1-13

Klatzky, R. L., Lederman, S., & Reed, C. (1987). There's More to Touch Than Meets the Eye: The Salience of Object Attributes for Haptics With and Without Vision, *Journal of Experimental Psychology: General*, 116(4), pp. 356-369 C

Klatzky, R. L., Lederman, S., & Reed, C. (1989). Haptic Integration of Object Properties: Texture, Hardness, and Planar Contour, *Journal of Experimental Psychology: Human Perception and Performance*, 15(1), pp. 45-57

Klatzky, R. L., & Lederman, S. J. (1990). "Intelligent Exploration by the Human Hand", In T. Venkataraman & T. Iberall (Eds.), *Dextrous Hands for Robots* (pp. 345), NY: Springer-Verlag C

Klatzky, R. L., Lederman, S. J., & Balakrishnan, J. D. (1991). Task-Driven Extraction of Object Contour by Human Haptics: I, *Robotica*, 9(1), pp. 43-51

Klatzky, R. L., Lederman, S. J., & Metzger, V. A. (1985). Identifying objects by touch: An "expert system", *Perception & Psychophysics*, 37(4), pp. 299-302

Kobayashi, H., & Nakamura, H. (1992). A Scaled Teleoperation. In *Proc. IEEE Workshop on Robot and Human Communication*, pp. 269-274, Tokyo, Japan

Kontarinis, D. A., & Howe, R. D. (1993). Tactile display of contact shape in dextrous manipulation. In *American Society of Mechanical Engineers Winter Annual Meeting*, pp. 81-88, New Orleans, LA

Kontarinis, D. A., & Howe, R. D. (1995). Tactile display of vibratory information in teleoperation and virtual environments, *Presence*

Kosuge, K., Fujisawa, Y., & Fukuda, T. (1992). Interface Design for Man-Machine Mechanical Interactions. In *IEEE International Workshop of Robot and Human Communication*,

Kotoku, T., Komoriya, K., & Tanie, K. (1992). A Force Display System for Virtual Environments and its Evaluation. In *Proc. IEEE International Workshop on Robot and Human Communication*, pp. 246-251, Tokyo, Japan

Kruskal, J. B., & Wish, M. (1978). *Multidimensional Scaling*. Sage Publications

Kuba, Y., Wada, M., & Endo, H. (1992). An Interfacing Method Between an Artificial hand and Human. In *Proc. IEEE Workshop on Robot and Human Communication*, pp. 194-198, Tokyo, Japan

Lamb, G. D. (1983). Tactile Discrimination of Textured Surfaces: Peripheral Neural Coding in the Monkey, *Journal of Physiology*, 338, pp. 567-587

-
- Lamb, G. D. (1983). Tactile Discrimination of Textured Surfaces: Psychophysical Performance Measurements in Humans, *J. Physiol.*, pp. 551-505
- Lambert, L. M., & Lederman, S. J. (1989). An Evaluation of the Legibility and Meaningfulness of Potential Map Symbols, *Journal of Visual Impairment & Blindness*, pp. 397-403
- LaMotte, R. H., & Srinivasan, M. A. (1990). "Surface Microgeometry: Tactile Perception and Neural Encoding", In O. Franzen & J. Westman (Eds.), MacMillan Press
- Lapham, L. H. (1964, April 18) *The Feely is Here*. Saturday Evening Post, p. 28-29
- Lathrop, R. H., Webster, T. A., & Smith, T. F. (1987). Ariadne: Pattern-Directed Inference and Hierarchical Abstraction in Protein Structure Recognition, *Communications of the ACM*, 30(11), pp. 909-921
- Lederman, S. J. (1974). Tactile roughness of grooved surfaces: The touching process and effects of macro- and microsurface structure, *Perception & Psychophysics*, 16(2), pp. 385-395 C
- Lederman, S. J. (1976). The "Callus-thenics" of Touching, *Canadian Journal of Psychology*, pp. 82-89
- Lederman, S. J. (1977). Heightening Tactile Impressions of Texture. In G. Gordon (Ed.), *Satellite Symposium on Active Touch*, pp. 1-15, Beaune, France
- Lederman, S. J. (1979). Auditory texture perception, *Perception*, 8, pp. 93-103
- Lederman, S. J. (1982). "The Perception of Texture by Touch", In W. Schiff & E. Foulke (Eds.), *Tactual perception: A sourcebook* (pp. 130-166), New York: Cambridge University Press
- Lederman, S. J. (1985). "Tactual Roughness Perception in Human: A Psychological Assessment of the Role of Vibration", In I. Darian-Smith & A. Goodwin (Eds.), *Hand function and the neocortex* (pp. 77-92), Berlin: Springer-Verlag
- Lederman, S. J. (1991). "Skin and Touch", In Academic: San Diego
- Lederman, S. J., & Abbott, S. G. (1981). Texture Perception: Studies of Intersensory Organization Using a Discrepancy Paradigm, and Visual versus Tactual Psychophysics, *Journal of Experimental Psychology*, 7(4), pp. 902-915

Lederman, S. J., & Browse, R. A. (1988). "The Physiology and Psychophysics of Touch", In P. Dario (Ed.), *Sensors and Sensory Systems for Advanced Robots* (pp. 71-91), Berlin: Springer-Verlag

Lederman, S. J., Browse, R. A., & Klatzky, R. L. (1988). Haptic processing of spatially distributed information, *Perception & Psychophysics*, 44(3), pp. 222-232

Lederman, S. J., & Kinch, D. H. (1979). Texture in Tactual Maps and Graphics for the Visually Handicapped, *Visual Impairment and Blindness*, (June), pp. 217-226

Lederman, S. J., & Klatzky, R. (1990). "Haptic Exploration and Object Representation", In M. Goodale (Ed.), *Vision & Action: the Control of Grasping* (pp. 367), New Jersey: Ablex

Lederman, S. J., & Klatzky, R. L. (1987). Hand Movements: A Window into Haptic Object Recognition, *Cognitive Psychology*, 19(3), pp. 342-368

Lederman, S. J., & Klatzky, R. L. (1990). Haptic Classification of Common Objects: Knowledge-Driven Exploration, *Cognitive Psychology*

Lederman, S. J., Klatzky, R. L., & Bajcsy, R. (1987). *Haptic Exploration in Humans and Machines: An Initial Overview* Office of Naval Research Technical Report 87-01).

Lederman, S. J., Klatzky, R. L., & Balakrishnan, J. D. (1991). Task-Driven Extraction of Object Contour by Human Haptics: II, *Robotica*, 9(2), pp. 179-188

Lederman, S. J., Klatzky, R. L., & Barber, P. O. (1985). Spatial and Movement-Based Heuristics for Encoding Pattern Information Through Touch, *Journal of Experimental Psychology: General*, 114(1), pp. 33-49

Lederman, S. J., Klatzky, R. L., Chataway, C., & Summers, C. D. (1990). Visual mediation and the haptic recognition of two-dimensional pictures of common objects, *Perception & Psychology*, 47(1), pp. 54-64

Lederman, S. J., & Taylor, M. M. (1972). Fingertip force, surface geometry, and the perception of roughness by active touch, *Perception & Psychophysics*, 12(5), pp. 401-408 C

Lederman, S. J., Thorne, G., & Jones, B. (1986). Perception of Texture by Vision and Touch: Multidimensionality and Intersensory Integration, *Journal of Experimental Psychology*, 12(2), pp. 169-180

Loeb, G. E. (1985). "What The Cat's Hindlimb Tells The Cat's Spinal Cord", In W. J. P. Barnes & M. H. Gladden (Eds.), *Feedback and Motor Control in Invertebrates and Vertebrates* (pp. 173-186), London: Croom Helm Ltd.

Loomis, J. M., & Lederman, S. J. (1986). "Tactual Perception", In K. R. Boff, L. Kaufman, & J. P. Thomas (Eds.), *Handbook of Perception and Human Performance* (pp. 31-1 - 31-41), New York: Wiley C

Mackel, R., Kunesch, E., Waldhor, F., & Stuppler, A. (1983). Reinnervation of Mechanoreceptors in the Human Glabrous Skin Following Peripheral Nerve Repair, *Brain Research*, 268, pp. 49-65

MacLean, K. E., & Durfee, W. K. (1991). *Rapid Prototyping of Physical Human Interfaces: Preliminary Thoughts* (INTERNAL). MIT Dept. of Mech. E.

Marbot, P. H., & Hannaford, B. (submitted). Mini Direct Drive Robot for Biomedical Applications, *IEEE Transactions on Robotics & Automation*

Marchak, F. M. (1988). *Fractal Geometry as a Model of Unpatterned Human Texture Perception*. The Analytic Sciences Corporation

Marchetti, F. M., & Lederman, S. J. (1983). The haptic radial-tangential effect: Two tests of Wong's "moments-of-inertia" hypothesis, *Bulletin of the Psychonomic Society*, 21(1), pp. 43-46

Mark, W. R., & Randolph, S. C. (1994). *UNC-CH Force Feedback Library #TR94-056*. University of North Carolina at Chapel Hill, Computer Science Dept.

Marks, J. (1991). A Formal Specification Scheme for Network Diagrams that Facilitates Automated Design, *Journal of Visual Languages and Computing*, 2(4), pp. 395-414 C

Massie, T. H. (1993). *Design of a Three Degree of Freedom Force-Reflecting Haptic Interface*. SB, Electrical Engineering and Computer Science, MIT

Massie, T. H., & Salisbury, J. K. J. (1993). *Force Reflecting Haptic Interface* Filed Oct 1, 1993. U.S Patent pending T

Massie, T. H., & Salisbury, K. (1994). The PHANToM Haptic Interface: A Device for Probing Virtual Objects. In *Proceedings of the ASME Winter Annual Meeting, Symposium on Haptic Interfaces for Virtual Environment and Teleoperator Systems*, Chicago, IL

Meckler (1991). *VR Conference and Exhibition - Final Program*. Meckler Conference New York

Menzel, P., & Haffner, P. (1991) *Virtual Reality: DIE WELT, DIE WIR UNS SELBER MACHEN*. GEO, p. 128-146 T

Millman, P., Stanley, M., Grafing, P., & Colgate, J. E. (1992). A system for the implementation and kinesthetic display of virtual environments. In *Proceedings of 1992 SPIE #1833*

Millman, P. A., & Colgate, J. E. (1994). Experimental Study of Haptic Information Pickup in Manipulation. In *Telem manipulator Technology, Proceedings of 1994 SPIE*

Millman, P. A., Stanley, M., & Colgate, J. E. (1993). Design of a High Performance Haptic Interface to Virtual Environments. In *VRAIS'93*, pp. 216-222, Seattle

Minsky, M. D. R. (1995). *Computational Haptics: The Sandpaper System for Synthesizing Texture for with a Force-Feedback Haptic Display*. Doctor of Philosophy, Massachusetts Institute of Technology

Minsky, M., Ouh-young, M., Steele, O. W., Brooks, F. P., Jr., & Behensky, M. (1990). Feeling and Seeing: Issues in Force Display. In *Computer Graphics, Proceedings of Siggraph Symposium on 3D Real-Time Interactive Graphics*, Vol. 24, Snowbird, UT C

MIT Course 6.023J Notes, *Lecture 13: Muscles got Feelings, too*, MIT Electrical Engineering Department

Morley, J. W., & Goodwin, A. W. (1987). Sinusoidal Movement of a Grating Across the Monkey's Fingerpad: Temporal Patterns of Afferent Fiber Responses, *The Journal of Neuroscience*, 7(7), pp. 2181-2191

Morley, J. W., Goodwin, A. W., & Darian-Smith, I. (1983). Tactile Discrimination of Gratings, *Experimental Brain Research*, (49), pp. 291-299

Napier, J. (1980). *Hands*. New York: Pantheon Books

Nguyen, C. N. (1987). *Study of Cutaneous Sensory System*. NASA Ames INTERNAL

Niven, L. (1976). *The Long Arm of Gil Hamilton*. New York: Ballantine

-
- Noll, A. M. (1971). *Man-Machine Tactile Communication*. Doctor of Philosophy, Polytechnic Institute of Brooklyn T
- Noll, A. M. (1976). Teleportation Through Communications, *IEEE Transactions on Systems, Man and Cybernetics*, June, pp. 754-756
- Noll, M. (1972). Man-Machine Tactile Communication, *Journal of the Society for Information Display*, (July/Aug)
- Ouh-young, M. (1990). *Force Display In Molecular Docking*. Ph.D. dissertation, Computer Science, University of North Carolina at Chapel Hill C T
- Ouh-young, M., Beard, D. V., & Frederick P. Brooks, J. (1989). Force display Performs Better than Visual Display in a Simple 6D Docking Task. In *Proceedings 1989 IEEE International Conference on Robotics and Automation*, Vol. 3, pp. 1462-1466, Scottsdale, AZ T
- Ouh-young, M., Pique, M., Hughes, J., Srinivasan, N., & Brooks, F. P., Jr. (1988). Using a Manipulator for Force Display in Molecular Docking. In *Proceedings of 1988 IEEE Robotics and Automation Conference*, Vol. 3, pp. 1824-1829, Philadelphia, PA T
- Pang, X. D., Tan, H. Z., & Durlach, N. I. (1991). Manual discrimination of force using active finger motion, *Perception & Psychophysics*, 49(6), pp. 531-540
- Pearson, G., & Weiser, M. (1986). *Moles: A Class of Foot-Operated Cursor-Positioning Devices*. University of Maryland
- Pentland, A. P. (1984). Fractal-Based Description of Natural Scenes, *IEEE Transactions on Pattern Analysis and Machine Intelligence*, PAMI-6(6), pp. 661-674
- Perlin, K. (1985). An Image Synthesizer. In *Computer Graphics, Proceedings of Siggraph '85*, Vol. 19, pp. 287-296, San Francisco, CA C
- Phillips, J. R., & Johnson, K. O. (1981). Tactile Spatial Resolution. II. Neural Representation of Bars, Edges, and Gratings in Monkey Primary Afferents, *Journal of Neurophysiology*, 46(6), pp. 1193-1203
- Phillips, J. R., & Johnson, K. O. (1981). Tactile Spatial Resolution. III. A Continuum Mechanics Model of Skin Predicting Mechanoreceptor Responses to Bars, Edges, and Gratings, *Journal of Neurophysiology*, 6, pp. 1204-1225

-
- Phillips, J. R., Johnson, K. O., & Hsiao, S. S. (1988). Spatial pattern representation and transformation in monkey somatosensory cortex, *Proc. Natl. Acad. Sci. USA*, 85, pp. 1317-1321
- Picard, R. W. (1992). Gibbs random fields: temperature and parameter analysis. In *ICASSP*, Vol. 3, pp. 45-48, San Francisco, CA C
- Picard, R. W., Kabir, T., & Liu, F. (1993). Real-Time Recognition with the entire Brodatz Texture Database. In *1993 IEEE Conference on CVPR*, New York
- Pieper, S. D. (1992). *CAPS: Computer-Aided Plastic Surgery*. Doctor of Philosophy, Massachusetts Institute of Technology
- Rao, A. R., & Lohse, G. I. (1993). Towards a Texture Naming System: Identifying Relevant Dimensions of Texture. In *IEEE Conference on Visual*, San Jose C
- Rheingold, H. (1991). *Virtual Reality*. New York: Simon & Schuster C
- Rosen, M. J., & Adelstein, B. D. (1984). Design of a Two-degree-of-freedom manipulandum for tremor research, *Proceedings of IEEE Robotics and Automation*
- Rosenberg, L. B. (1993). Virtual Fixtures: Perceptual Tools for Telerobotic Manipulation. In *VRAIS '93*, Seattle, WA C T
- Rosenberg, L. B., & Adelstein, B. D. (1993). Perceptual Decomposition of Virtual Haptic Surfaces. In *Proceedings IEEE 1993 Symposium on Research Frontiers in Virtual Reality*, pp. 46-53, San Jose, CA C
- Russo, M. A. (1988). *A Control Analysis of a Hybrid Motor-Brake System for Tactile Simulations*. Bachelor of Science, Massachusetts Institute of Technology C T
- Russo, M. A. (1990). *The Design and Implementation of a Three Degree of Freedom Force Output Joystick*. Master of Science, Mechanical Engineering, Massachusetts Institute of Technology C T
- Sagar, M., Bullivant, D., Mallinson, G., Hunter, P., & Hunter, I. (1994). A Virtual Environment and Model of the Eye for Surgical Simulation. In *Computer Graphics Annual Conference Series, Proceedings of SIGGRAPH'94*, pp. 205-212, Orlando, FL
- Salisbury, J. K., & Srinivasan, M. A. (1992). "Haptic Interfaces", In V. MIT (Ed.), *BBN Report No. 7661 Virtual Environment Technology for Training (VETT)*, BBN C

Salisbury, K., Brock, D., & Chiu, S. (1985). Integrated Language, Sensing and Control for a Robot Hand. In *3rd ISRR*, Gouvieux, France C T

Salisbury, K., Brock, D., Massie, T., Swarup, N., & Zilles, C. (1995). Haptic Rendering: Programming Touch Interaction with Virtual Objects. In *Proceedings of 1995 ACM Symposium on Interactive 3D Graphics*, Monterey, CA

Salisbury, K., & Massie, T. (1994). The PHANToM Haptic Interface. In *Proc. AAAI Spring Symposium Series, Toward Physical Interaction and Manipulation*, Stanford, CA

Salisbury, K., & Massie, T. (1995) **WWW Page** <http://www.ai.mit.edu/projects/handarm-haptics/haptics.html>

Salisbury, M. P., Anderson, S. E., Barzel, R., & Salesin, D. H. (1994). Interactive Pen-and-Ink Illustration. In *Proceedings of SIGGRAPH'94, Computer Graphics Annual Conference Series 1994*, pp. 101-118, Las Vegas, NV

Satava, R., Morgan, K., Sieburg, H., Mattheus, R., & Christensen, J. (Eds.) (1995). *Interactive Technology and the New Paradigm for Healthcare*. Washington, DC: IOS Press

Sathian, K., Goodwin, A. W., John, K. T., & Darian-Smith, I. (1989). Perceived Roughness of a Grating: Correlation with Responses of Mechanoreceptive Afferents Innervating the Monkey's Fingerpad, *Journal of Neuroscience*, 9(4), pp. 1273-1279

Schmult, B. (1990). *Data Analysis with a Force-Reflective Joystick*. AT&T Bell Laboratories Technical Memo, (available from author) C

Schneider, W. (1988). The Tactile Array Stimulator, *Johns Hopkins API Technical Digest*, 9(1), pp. 39-43

Seligman, D. D., & Feiner, S. (1991). Automated Generation of Intent-based 3D Illustrations. In *Computer Graphics, Proceedings of SIGGRAPH'91*, Vol. 25, pp. 123-132, Las Vegas, NV

Sharon, A., Hogan, N., & Hardt, D. E. (1988). High Bandwidth Force Regulation and Inertia Reduction Using a Macro/Micro Manipulator System. In *Proceedings of the IEEE International Conference on Robotics and Automation*, Vol. 1, pp. 126-132, Philadelphia, PA

Sheridan, T. (1992). *Telerobotics, Automation, and Human Supervisory Control*. MIT Press C

Sherrick, C. E., & Cholewiak, R. W. (1986). "Cutaneous Sensitivity", In K. R. Boff, L. Kaufman, & J. P. Thomas (Eds.), *Handbook of Perception & Human Performance* (pp. 12-1 - 12-58), New York: Wiley C

Shimoga, K. B. (1993). A Survey of Perceptual Feedback Issues in Dexterous Telemanipulation: Part I. Finger Force Feedback. In *VRAIS '93*, pp. 263-270, Seattle, WA C

Shimoga, K. B. (1993). A Survey of Perceptual Feedback Issues in Dexterous Telemanipulation: Part II. Finger Touch Feedback. In *VRAIS '93*, pp. 271-279, Seattle, WA C

Shin, D., Muramoto, T., Hashimoto, S., & Ohteru, S. (1992). A Virtual Space Action Communication System for BUNRAKU. In *Proc. IEEE Workshop on Robot and Human Communication*, pp. 93-98, Tokyo, Japan

Simanaitis, D. (1989, August) (*Hard*) *Drivin' Impressions*. Road and Track, p. 88-94 T

Sinclair, R., & Burton, H. (1988). Responses from Area 3b of Somatosensory Cortex to Textured Surfaces during Active Touch in Primate, *Somatosensory Research*, 5(4), pp. 283-310

Small, D. (1991). Simulating Watercolor by Modeling Diffusion, Pigment, and Paper Fibers. In *Proceedings of the SPIE Conference on Imaging*, Vol. 1460, paper 15, San Jose, CA C

Smith, M. J. (1988). *Tactile Interface for Three-Dimensional Computer-simulated Environments: Experimentation and the Design of a Brake-Motor Device*. Master of Science, Mechanical Engineering, Massachusetts Institute of Technology C T

Solomon, H. Y., & Turvey, M. T. (1988). Haptically Perceiving the Distances Reachable With Hand-Held Objects, *Journal of Experimental Psychology*, 14(3), pp. 404-427

Solomon, H. Y., Turvey, M. T., & Burton, G. (1989). Perceiving Extents of Rods by Wielding: Haptic Diagonalization and Decomposition of the Inertia Tensor, *Journal of Experimental Psychology: Human Perception and Performance*, 15(1), pp. 58-68

Son, J., Monteverde, E. A., & Howe, R. D. (1994). A tactile sensor for localizing transient events in manipulation. In *Proceedings of the 1994 IEEE International Conference on Robotics and Automation*, pp. 471-476, San Diego, CA T

Srinivasan, M. A. (1989). Surface Deflection of Primate Fingertip Under Line Load, *Journal of Biomechanics*, 22(4), pp. 343-349

Srinivasan, M.A. & LaMotte R. H., (1991) "Encoding of shape in the responses of cutaneous mechanoreceptors" In *Information Processing in the Somatosensory System*, Eds: O. Franzen and J. Westman, Wenner-Gren Intl. Symposium Series, Macmillan

Srinivasan, M. A., Whitehouse, J. M., & LaMotte, R. H. (1990). Tactile Detection of Slip: Surface Microgeometry and Peripheral Neural Codes, *Journal of Neurophysiology*, 63(6), pp. 1323-1332

Stansfield, S. A. (1989). *Robotic Grasping of Unknown Objects: A Knowledge-Based Approach*. SAND89-1087 UC-32 Sandia National Laboratories

Stelarc (1991). Prosthetics, Robotics and Remote Existence: Postevolutionary Strategies, *Leonardo*, 24(5), pp. 591-595

Stevens, J. C. (1982). Temperature can sharpen tactile acuity, *Perception and Psychophysics*, 31(6), pp. 577-580

Stevens, S. S., & Harris, J. R. (1962). The scaling of subjective roughness and smoothness, *Journal of Experimental Psychology*, 64, pp. 489-494

Stone, R. J. (1990). *TELETACT* Trade Mark No. 1403130). UK National Advanced Robotics Research Center

Stone, R. J. (1991). The UK Virtual Reality & Telepresence Project. In *1991 Computer Graphics Conference*, pp. 131-140, London

Sturman, D. J. (1992). *Whole-hand Input*. Ph.D. dissertation. Media Arts and Sciences, Massachusetts Institute of Technology C

Sutherland, I. E. (1965). The Ultimate Display. In *IFIP Congress*, Vol. 2, pp. 506-508, C T

Swarup, N. (1995) **WWW Page** http://www.ai.mit.edu/people/nswarup/look_and_feel.html

Tachi, S., Arai, H., & Maeda, T. (1989). Development of anthropomorphic tele-existence slave robot. In *Proceedings of International Conference on Advance Mechatronics*, Tokyo, Japan T

Tadros, A. H. (1990). *Control System Design for a Three Degree of Freedom Virtual Environment Simulator Using Motor/Brake Pair Actuators*. Massachusetts Institute of Technology

Tamura, H., Mori, S., & Yamawaki, T. (1978). Textural Features Corresponding to Visual Perception, *IEEE, SMC-8*(6), pp. 460-473 C

Tan, H. Z., Pang, Z. D., & Durlach, N. I. (1992). "Manual Resolution of Length, Force, and Compliance", In H. Kazerooni (Ed.), *DSC - Vol 42, Advances in Robotics* (pp. 13-18), ASME C

Tan, H. Z., Srinivasan, M. A., Eberman, B., & Cheng, B. (1994). Human factors for the design of force-reflecting haptic interfaces, *Dynamic Systems and Control (ASME)*, 55(1), pp.

Taylor, M. M., & Lederman, S. J. (1975). Tactile roughness of grooved surfaces: A model and the effect of friction, *Perception & Psychophysics*, 17(1), pp. 23-36

Taylor, M. M., Lederman, S. J., & Gibson, R. H. (1973). "Tactual Perception of Texture", In E. C. Carterette & M. P. Friedman (Eds.), *Handbook of Perception* (pp. 251-271), California: Academic Press, N.Y.

Taylor, R. M., II, Robinett, W., Chi, V. L., Brooks, F. P., Jr., Wright, W. V., Williams, R. S., & Snyder, E. J. (1993). The Nanomanipulator: A Virtual-Reality Interface for a Scanning Tunneling Microscope. In *Proceedings of SIGGRAPH'93, Computer Graphics Proceedings, Annual Conference Series*, pp. 127-134, Anaheim, CA C T

TOUCHBALL (1989). *Baby's First Choice* (touch toy ball with different fabric segments). TOT Inc., Washington, DC

Truninger, R. (1992). Feeling the Overturn Stability of a Platform. In *Proc. IEEE Workshop on Robot and Human Communication*, pp. 241-245, Tokyo, Japan

Vallbo, A. B., & Johansson, R. S. (1984). Properties of cutaneous mechanoreceptors in the human hand related to touch sensation, *Human Neurobiology*

Van Doren, C. L. (1989). A model of spatiotemporal tactile sensitivity linking psychophysics to tissue mechanics, *The Journal of the Acoustical Society of America*, 85(5), pp. 2065-2080

Van Doren, C. L., Pelli, D. G., & Verrillo, R. T. (1987). A device for measuring tactile spatiotemporal sensitivity, *Journal of the Acoustical Society of America*, 81(6), pp. 1906-1916

Verrillo, R. T. (1966). Specificity of a cutaneous receptor, *Perception & Psychophysics*, 1, pp. 149-153

-
- Verrillo, R. T. (1966). Vibrotactile sensitivity and the frequency response of the Pacinian corpuscle, *Psychonomic Science*, 4, pp. 1
- Verrillo, R. T. (1966). Vibrotactile Thresholds for Hairy Skin, *Journal of Experimental Psychology*, 72(1), pp. 47-50
- Verrillo, R. T. (1968). "A duplex mechanism of mechanoreception", In D. R. Kenshalo (Ed.), *The Skin Senses*, Springfield, IL: C.C. Thomas
- Verrillo, R. T., & Gescheider, G. A. (1975). Enhancement and summation in the perception of two successive vibrotactile stimuli, *Perceptions & Psychophysics*, 18(2), pp. 128-136
- Verrillo, R. T., Gescheider, G. A., & Calman, B. G. (1981). *Vibrotactile Masking: Effects of One and Two-Site Stimulation*. Institute for Sensory Research, Syracuse University
- Verrillo, R. T., & Smith, R. L. (1976). Effect of stimulus duration on vibrotactile sensation magnitude, *Bulletin of the Psychonomic Society*, 8(2), pp. 112-114
- Verso, D., & Tice, S. E. (1990). *Virtual reality technology applied effectively can solve product development problems* (White paper - VR Assembly modelling application position paper). Sim-Graphics Engineering Corporation
- Wallace, R. (1993). Touch over the Phone. In *Siggraph '93 Interaction Exhibits*, T
- Williams, L. (1983). Pyramidal Parametrics. In *Computer Graphics, Proceedings of Siggraph'83*, pp. 1-11, C
- Winey, C. M. (1981). *Computer Simulated Visual and Tactile Feedback as an Aid to Manipulator and Vehicle Control* ONR Report contract N00014-77-C-0256. Massachusetts Institute of Technology
- Wlassich, J. J. (1986). *Nonlinear Force Feedback Impedance Control*. M.S. Thesis, Mechanical Engineering Dept., Massachusetts Institute of Technology
- Wright, P. K. (1985). A Manufacturing Hand, *Robotics and Computer-Integrated Manufacturing*, 2(1), pp. 13-23
- Yaniger, S. (1990). *Touch Sensing and Control Using Force Sensing Resistors*. Interlink Electronics

Yoshida, M. (1968). A psychometric analysis of textile handling, *Japanese Psychological Research*, 10(1), pp. 1-12 C

Yoshida, M. (1969). Dimensions of tactile impressions: I, *Japanese Psychological Research*, 10(3), pp. 123-137 C

Yoshida, M. (1969). Dimensions of tactile impressions: II, *Japanese Psychological Research*, 10(4), pp. 157-173 C

Zhuang, G. B. a. J. (1990). Dextrous telerobotics with force feedback - an overview Part 2: Control and implementation, *The State University of New Jersey*, 9, pp. 291-298

Zilles, C. (1995) **WWW Page** <http://www.mit.edu:8001/afs/athena.mit.edu/user/s/h/shade/www/research.html>

Zilles, C., & Salisbury, K. (1995). A Constraint-Based God Object Method for Haptic Display. In *IROS'95*, Tokyo, Japan

*Appendix A: Visual Representation of Version-1
and Version-2 Textures*

Key

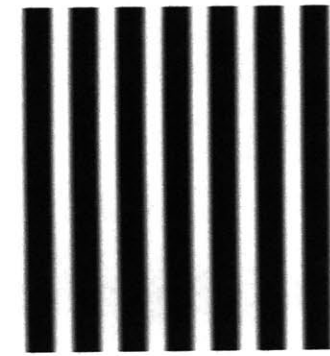

Height map

□ white = highest

■ black = lowest



Profile

An side view of the texture, showing the bumps and valleys

The profile shown corresponds to the top line of the square height map

barsB15W20_2

Stimulus name as used in experiments

barsB10W10_2 ("bars" are "gratings" in the text)

valley width (B) = 15

hill width (W) = 20

smoothing filter kernel size = 2

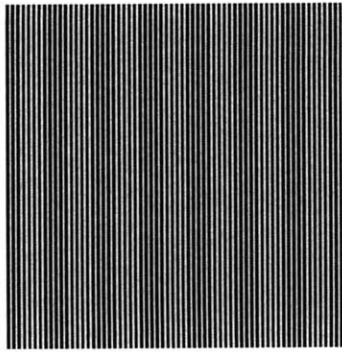

barsB2W2_.25

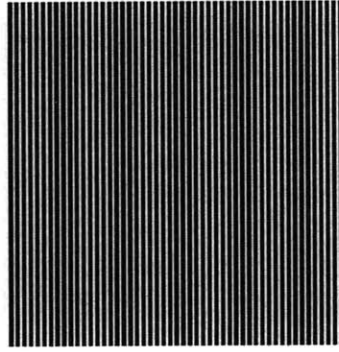

barsB2W3_.25

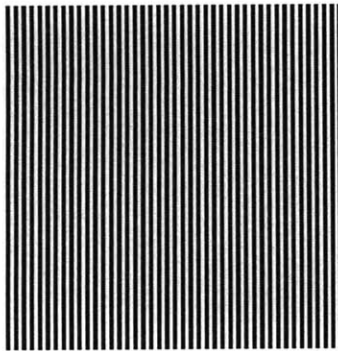

barsB3W3_.3

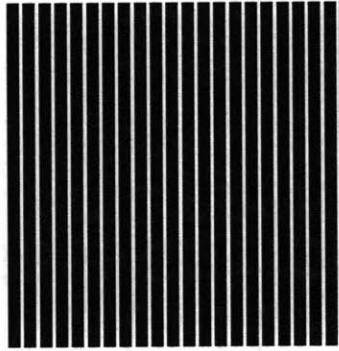

barsB3W12_.25

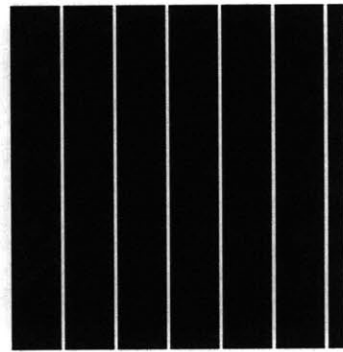

barsB3W27_.25

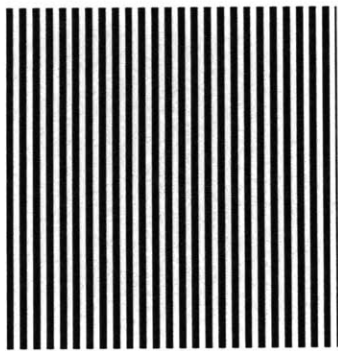

barsB5W5_.25

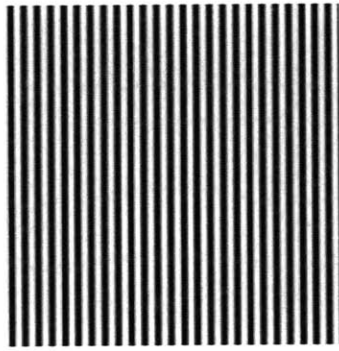

barsB5W5_1

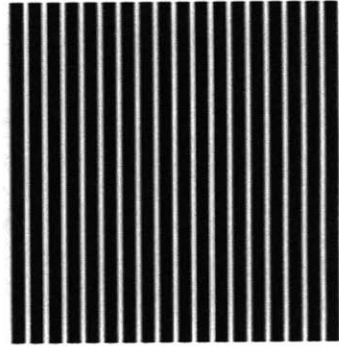

barsB5W10_1

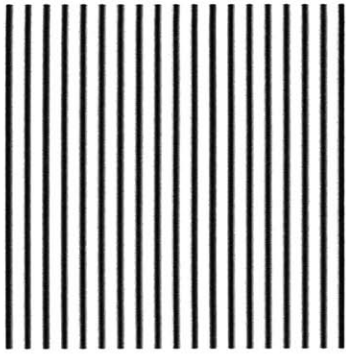

barsB10W5_1

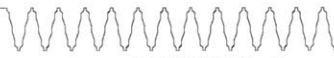
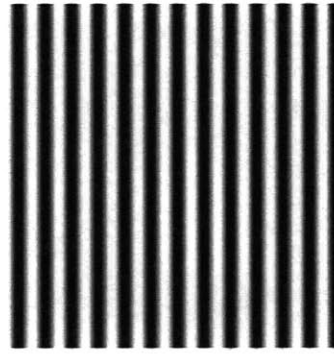

barsB10W10_2

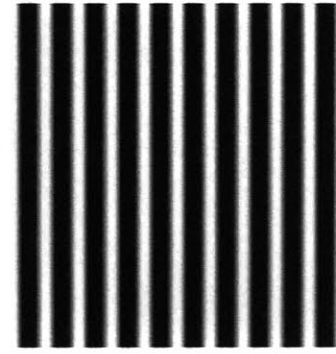

barsB10W15_2

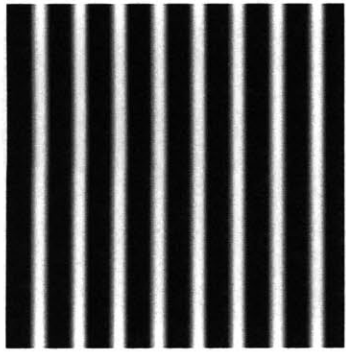

barsB10W20_2

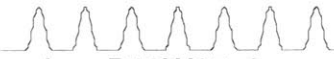
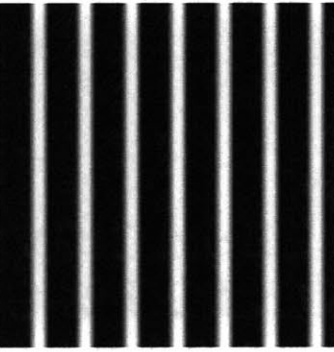

barsB10W25_2

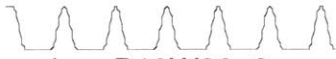

barsB10W30_2

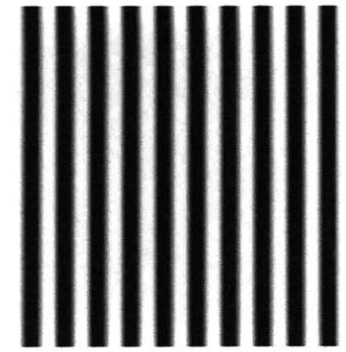

barsB12W13_2

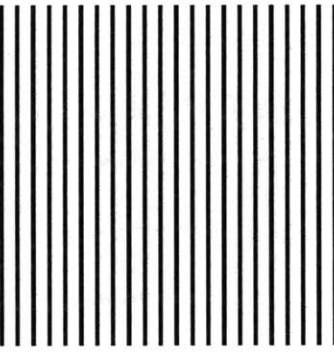

barsB12W3_.25

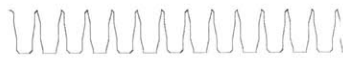
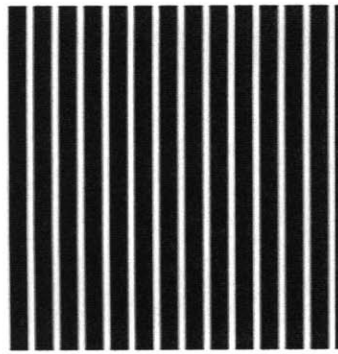

barsB5W15_1

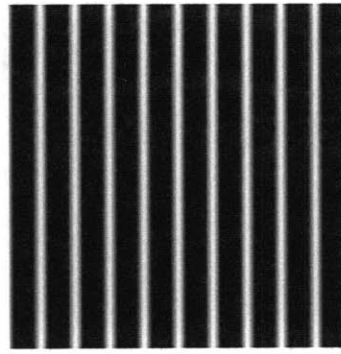

barsB5W20_2

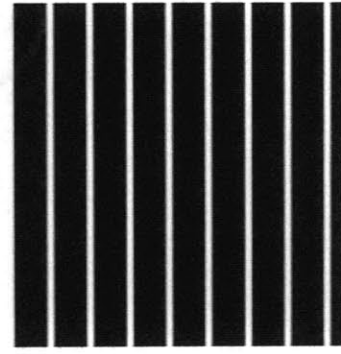

barsB5W25_1

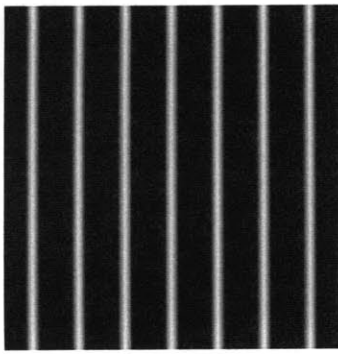

barsB5W30_2

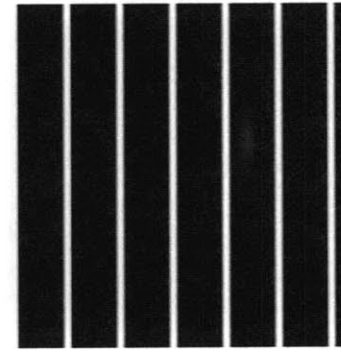

barsB5W35_1

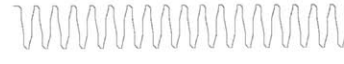
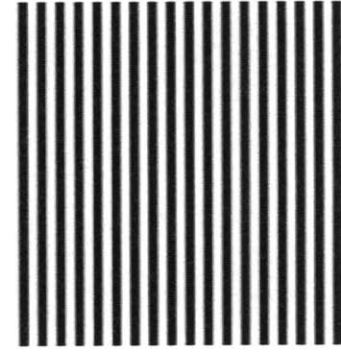

barsB7W7_1

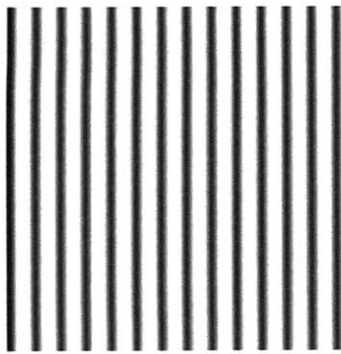

barsB15W5_2

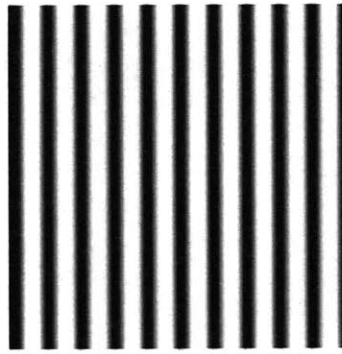

barsB15W10_2

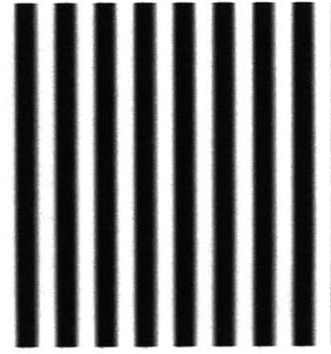

barsB15W15_2

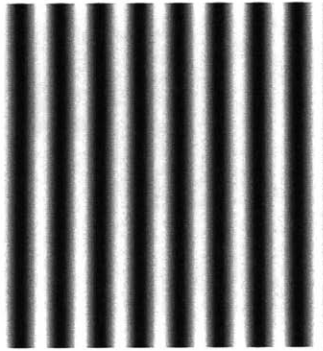

barsB15W15_4

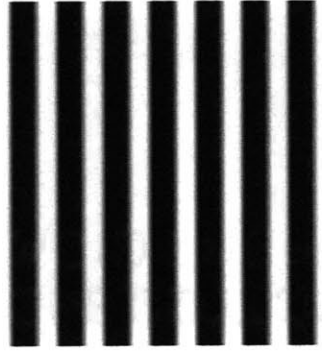

barsB15W20_2

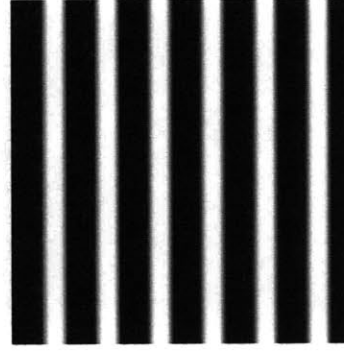

barsB15W25_2

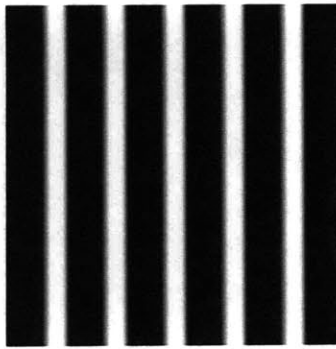

barsB15W30_2

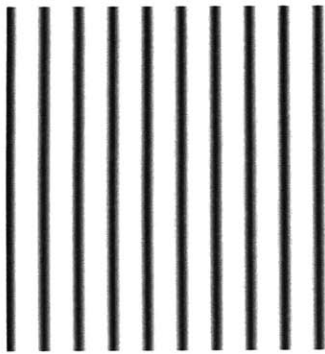

barsB20W5_2

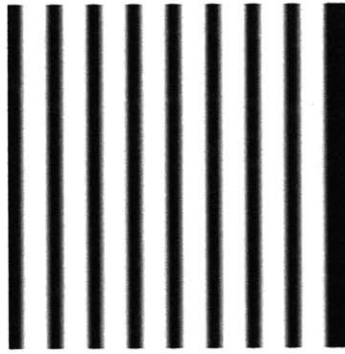

barsB20W10_2



barsB20W10_4

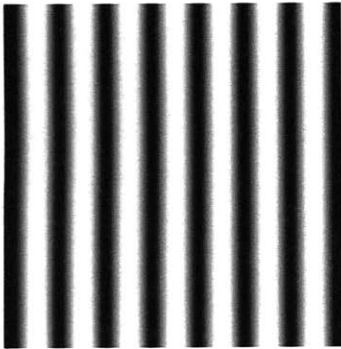

barsB20W15_2



barsB20W20_4

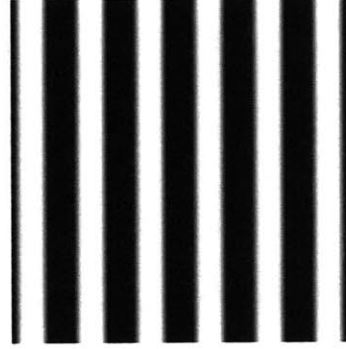

barsB20W25_2

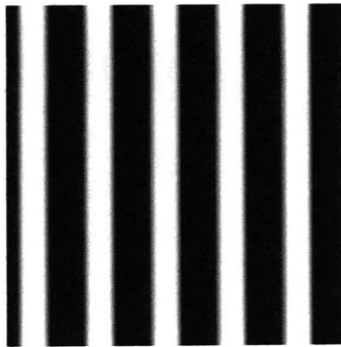

barsB20W30_2

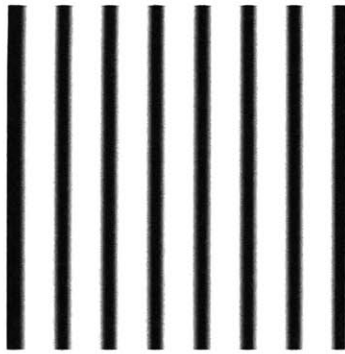

barsB25W10_2

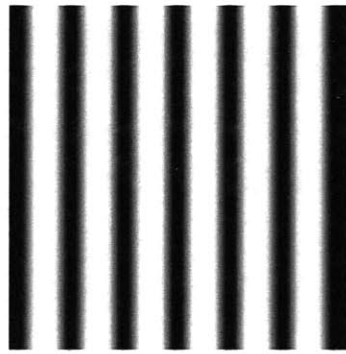

barsB25W15_4?

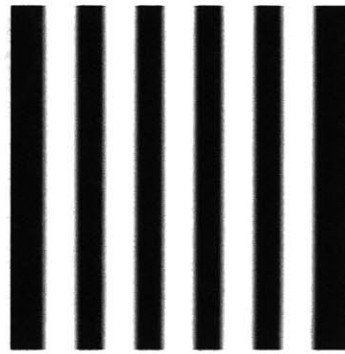

barsB25W20_2



barsB25W25_4

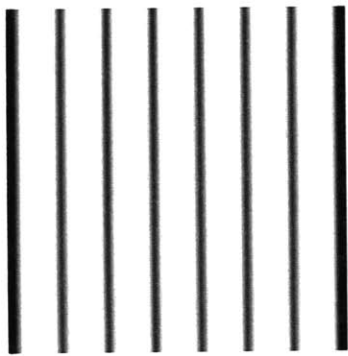

barsB30W5_2

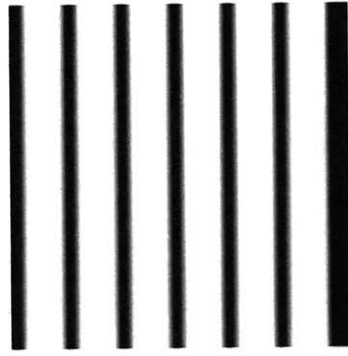

barsB30W10_2

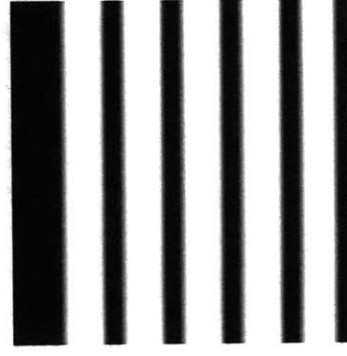

barsB30W15_2

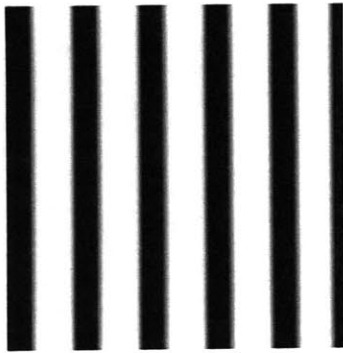

barsB30W20_2

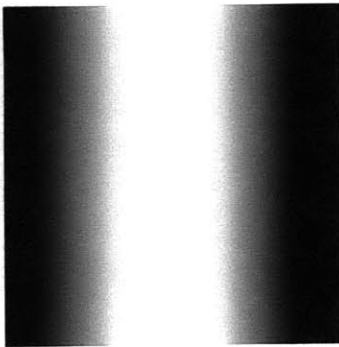

barsB128W128_25

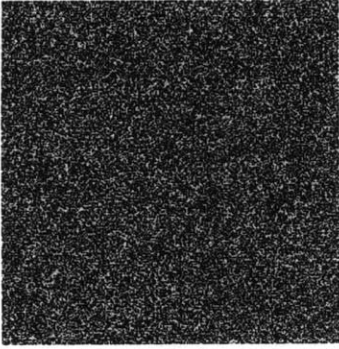

noise

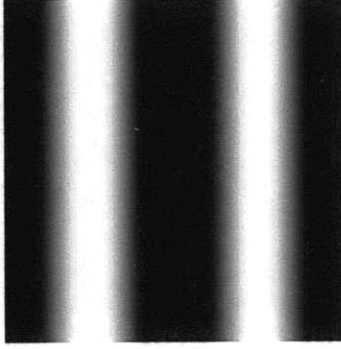

widestripes

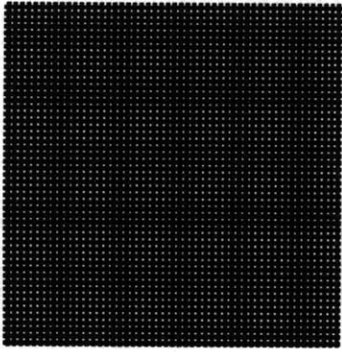

gridB2W33_1

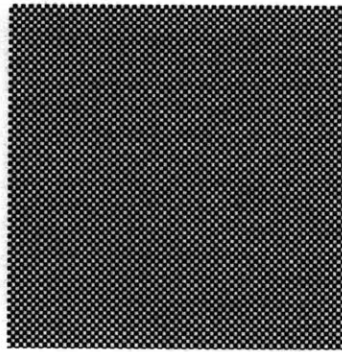

gridB3W3

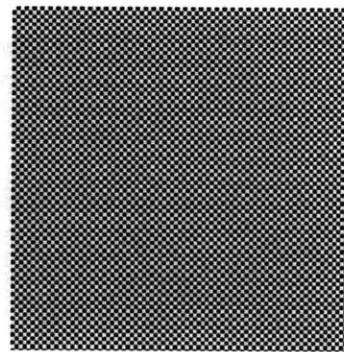

gridB3W3_25

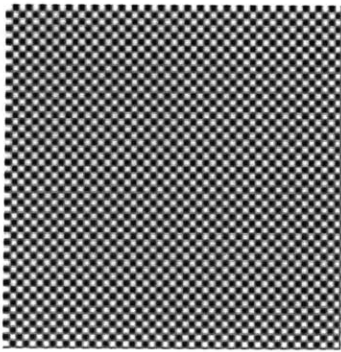

ZgridB5W5_1

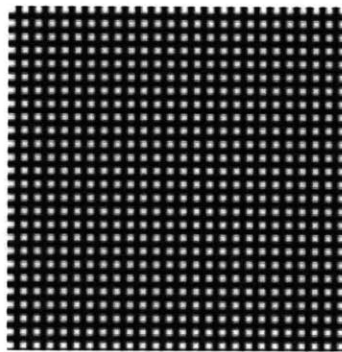

ZgridB5W5off5_1

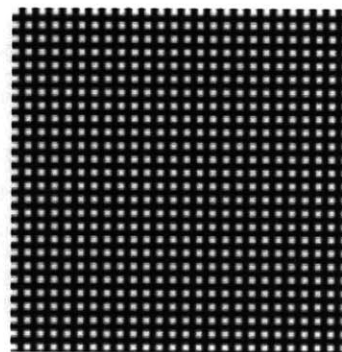

gridB5W10_1

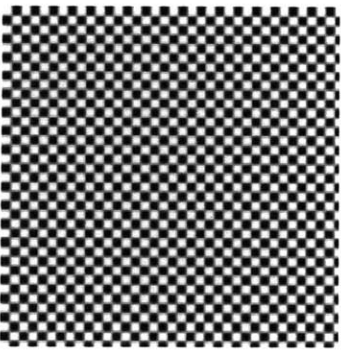

gridB7W7_1

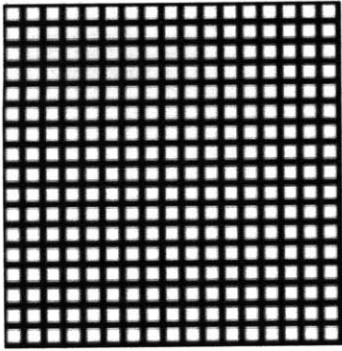

gridB10W5_1

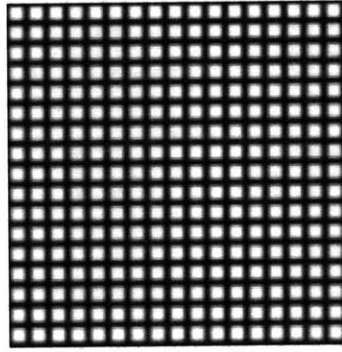

gridB10W5_1_1

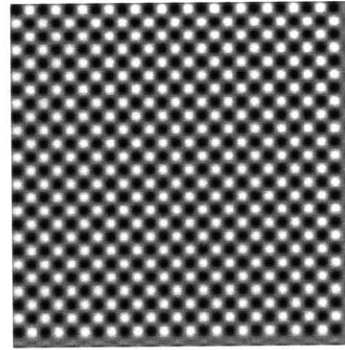

ZgridB10W10_2

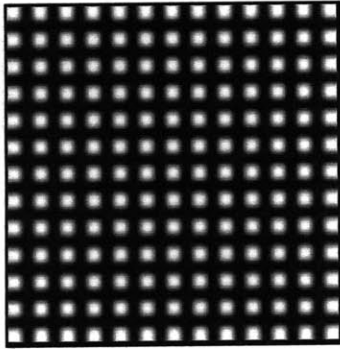

gridB10W20_2

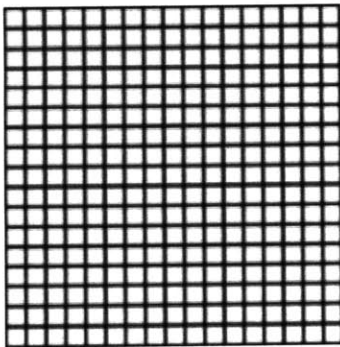

gridB12W3_1

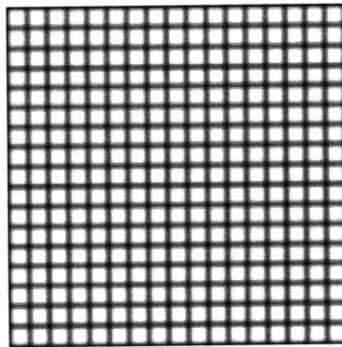

gridB12W3_1_1

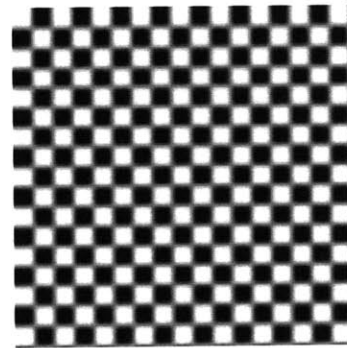

ZgridB15W15_2

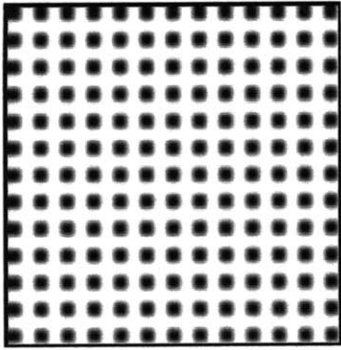

gridB20W10_2

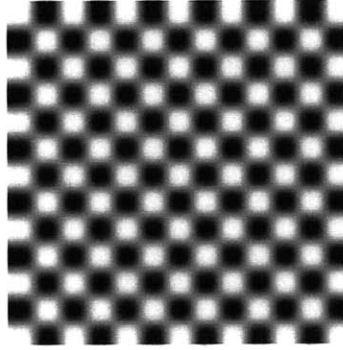

gridB20W20_4

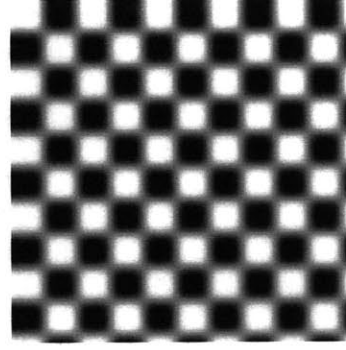

gridB25W25_4

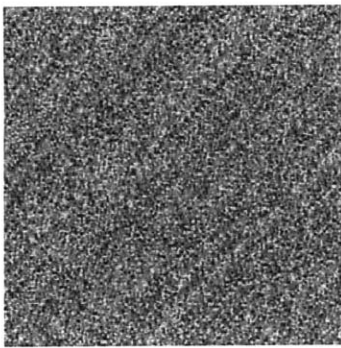

perlin2

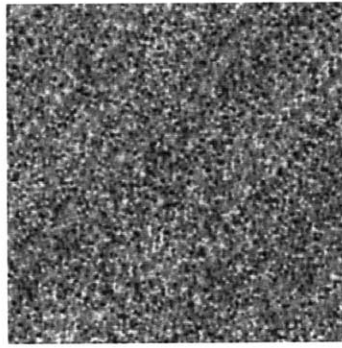

perlin3

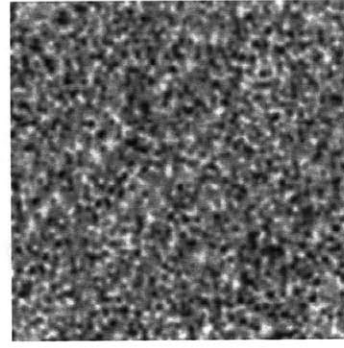

perlin5

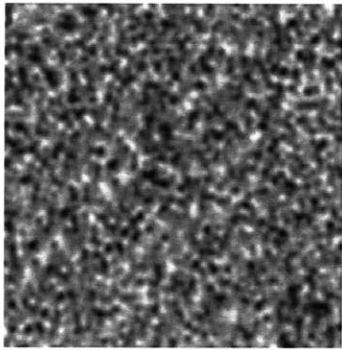

perlin6

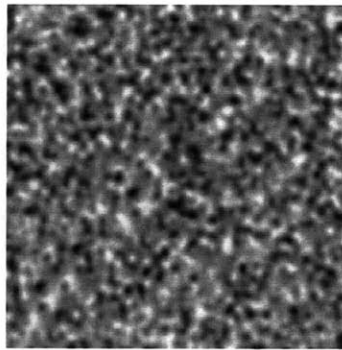

perlin7

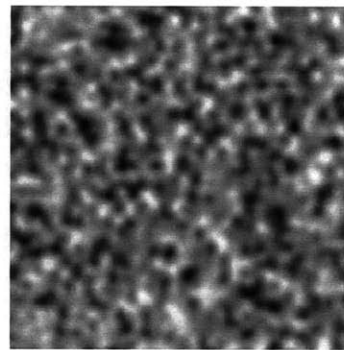

perlin10

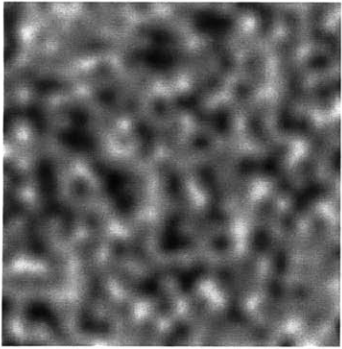

perlin15

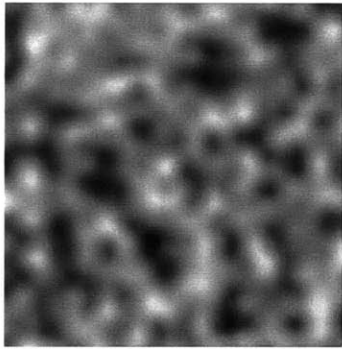

perlin20

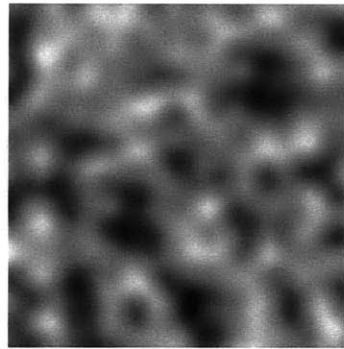

perlin25

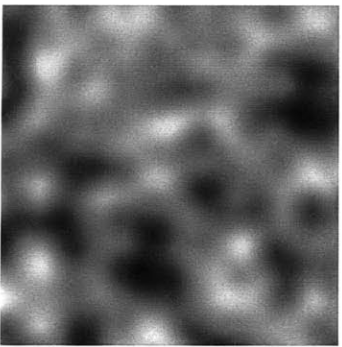

perlin30

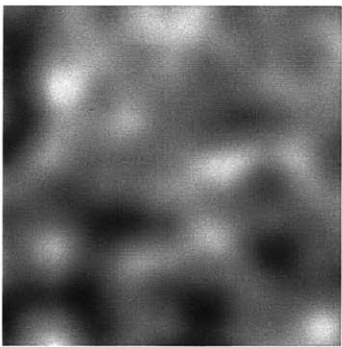

perlin40

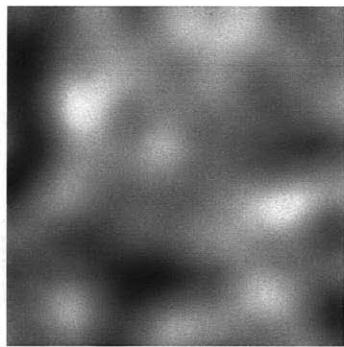

perlin50

0.7 mm

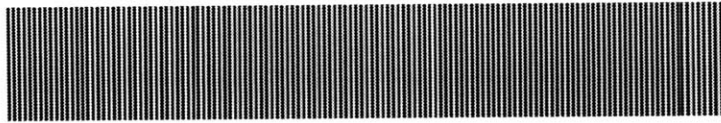

0.9 mm

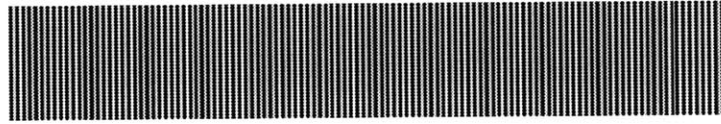

1.2 mm

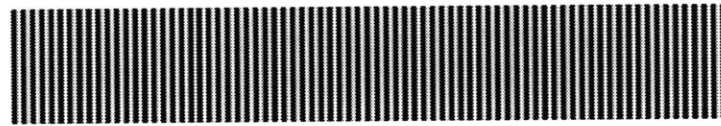

1.8 mm

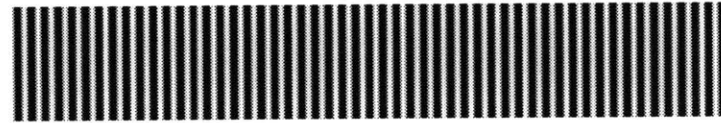

2.5 mm



3.7 mm

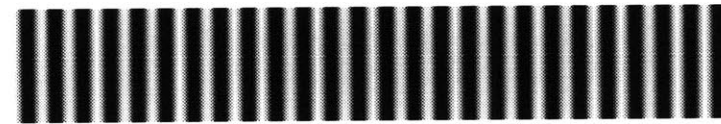

5.0 mm

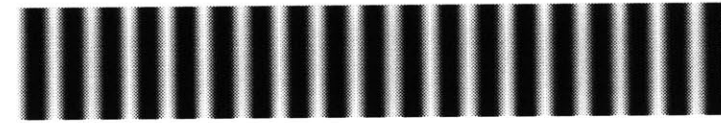

7.5 mm

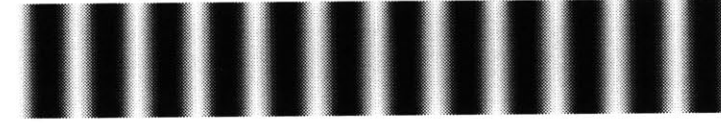

10.0 mm

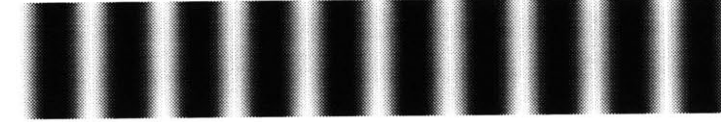

Appendix B: Sandpaper Reference Manual

Sandpaper Manual

1 Introduction

2 User Reference

2.1 Conceptual Overview

2.2 Windows

Workspace
Sliders

2.3 Menus

Apple
File
Texture, Physics, Arrays, Waves
Options

3 File Formats Reference

4 System Characteristics

1 Introduction

This document describes the *Sandpaper* application program. It is intended as a companion to Margaret Minsky's MIT Media Arts and Sciences dissertation, *Computational Haptics: The Sandpaper System for Synthesizing Texture for a Force-Feedback Display*.

The reader is expected to be familiar with the Apple Macintosh™ user interface. Familiarity with similar windowing systems may be adequate as a substitute.

Sandpaper is an application program that runs on a Macintosh. It displays a window within which rectangular patches of various shades and sizes can be created and positioned. These patches represent virtual textures, surfaces, and mechanical systems. If a force-feedback joystick is connected to the Macintosh, the joystick is commanded to display forces that depend on the position of the joystick cursor within these patches.

The core of *Sandpaper* was implemented in Think C 3.0 during the 1988-89 academic year, by Oliver Steele with help from Margaret Minsky and David Banks. Some parts are based on code by David Sturman. Improvements and additions were incorporated until the final version in 1993. It was ported to Think C 5.0 for the experiments described in Minsky's dissertation, and has since been ported to Think C 7.0 and MetroWerks 5.0 for profiling and data recovery.

2 User Reference

2.1 Conceptual Overview

Sandpaper displays a *workspace window*, to which the joystick coordinate system is mapped. Moving the joystick moves the *joystick cursor* (which can be shown or hidden) within the workspace window. The mouse is used to create and position rectangular *patches* within the window. When the joystick cursor lies within a patch, forces are displayed using the joystick. The forces depend upon characteristics of the patch.

There are four classes of patch prototypes: Textures, Physics, Arrays, and Waves. (The names are historical; not too much should be read into them.) *Texture* patches are mathematical models of physical systems, such as $F = -kx$ or $F = bv$. *Physics* patches are models with more state, that in general simulate physical objects, and may show animations within their patch regions. *Arrays* patches are surface maps that are sampled using the lateral-force gradient algorithm for force display. Note that Arrays are sampled at a resolution of one screen pixel per array item; this is lower than the resolution available from the joystick encoders. *Waves* patches are surface maps that are sampled at variable resolution.

Within each patch class, there are several prototypes. Each Texture or Physics patch prototype models a different equation. Each Array or Wave patch prototype uses a different surface map array.

A patch prototype is instantiated by choosing its name from a menu, and then dragging out a rectangle or clicking in the workspace window to create a patch. Patches may have state values that can be parameterized differently for each patch instantiation. These are controlled via the sliders in the *slider window*.

The state of the workspace can be saved and restored from a *workspace file*. A *movie file* specifies a sequence of workspace files; once a movie file is opened, additional menu support appears specifically for navigating among the workspaces listed in the movie file.

2.2 Windows

2.2.1 Workspace

The workspace window shows a cursor that represents the joystick position within the workspace, and colored and patterned rectangles that represent patches. In addition, the mouse is used to create, move, and delete patches. When the mouse is within the workspace window, its cursor is shown as well.

When the joystick cursor is inside a patch, the joystick is subject to forces generated by the patch procedure associated with that patch. Patches have a front-to-back ordering; only forces from the single frontmost patch are relayed to the joystick. *Front* patches occlude other patches.

When the joystick cursor is moved into a patch, the patch parameters are shown in the slider window. The name of the patch prototype patch is also italicized in the appropriate patch class menu.

New patches are created within the workspace window by dragging the mouse. If shift is pressed

while initiating the drag, a patch is created on top of another patch; otherwise, the existing patch is moved. The new patch is of the type checked in the patch class menus. If “Nothing” is checked, dragging the mouse does nothing.

A patch is repositioned by dragging it. If “Front” is checked in the Options menu, dragging a patch also brings it in front of other patches.

To delete a patch, the option key is pressed while clicking on the patch.

2.2.2 Sliders

The slider window is to the left of the workspace window. The top of the slider window shows the name and an optional description of the patch that was most recently touched by the joystick. The remainder of the window shows six sliders; each slider represents a different parameter value for this patch. If there are fewer than six parameters, the remaining sliders are blank. If there are more than six parameters, a popup menu beneath each slider can be used to set the parameter value that is associated with that slider. Dragging a slider thumb sets the parameter value for the current patch.

The slider window continues to show settings for the patch most recently touched by the joystick. There is a lag of about 0.25 seconds for switching the patch display in the slider window, in order to prevent the slider window updates from consuming appreciable computation time when the joystick is moved rapidly between several patches.

Clicking the black up-arrow to the right of a slider draws an upward triangle marker next to the slider’s current setting; clicking the black down-arrow draws a downward triangle marker. The settings for these triangles are specific to each patch, and they are remembered within a session until the patch is cleared (these settings are saved and restored by Save and Open). This feature was used in 1988-89 pilot experiments, to allow people to record a range of values within which a patch was judged to have certain characteristics.

2.3 Menus

File Edit Texture Physics Waves Arrays Options



menu

Standard Apple menu items,

About Taxel Planes...

Displays an alert box that lists author and sponsor credits for the Sandpaper application program.

File

menu

Commands to open and save files, print, show and hide the slider window, and to quit the Sandpaper application.

Clear

Deletes all patches from the workspace.

Open...

Prompts the user for a workspace file, clears all patches from the workspace, and adds the patches that were saved to the workspace file. Merge with... is used to add saved patches to an existing workspace without clearing it first.

Save

This command is only available when the current workspace was read from a workspace file by means of the “Open...” command. It stores the state of the workspace in that workspace file, overwriting its previous contents.

Save as...

Prompts the user for a file name, creates a workspace file with that name, and stores the state of the workspace in the workspace file. The workspace file can subsequently be loaded by means of the “Open...” or “Merge with...” commands.

The “Save as...” command is used to create a new workspace file, or to save the workspace state to a different file than the file that it was read from.

Save Text...

Prompts the user for a file name, creates a text file with that name, and stores the state of the workspace, in human-readable form, into that file. The Sandpaper application cannot be used to open the text file, and there is no automated means for setting the state of the workspace from the text file.

Merge with...

Prompts the user for a workspace file, and adds the patches in the workspace file to the workspace. Patches already in the workspace are not removed. The “Open...” command can be used to set the state of the workspace to its state when the patch file was saved, i.e., to first clear patches from the workspace.

Slider Window

Shows or hides the slider window.

Edit menu

Standard editing commands. The commands in the Edit menu are not used in the Sandpaper application.

Texture | **Physics Waves Arrays** menus

These menus list the names of haptic patches of various types. Items in the Texture menu are simple mathematical models, with equations such as $F=kv$. Items in the Physics menu are dynamic textures. Waves are sampled textures with precomputed height maps and shaded visual representations, and Arrays are height maps that can be sampled at variable spatial periods.

Exactly one item in the Texture, Physics, Waves, and Arrays menus is checked at any time. Dragging out a rectangle in the workspace window creates a patch of the type named by the checked item. (An exception is the Nothing item in the Texture menu — when this item is checked, the feature of dragging to create a patch is disabled.)

If the mouse is over a patch, the name of that patch type in the menu is italicized.

Definitions of variables:

- F output force
- p joystick position. The center of the patch is (0, 0).
- v joystick velocity
- a joystick acceleration
- k spring constant, settable by slider
- b viscosity constant, settable by slider
- P period, settable by slider
- A amplitude, settable by slider
- f frequency, settable by slider
- p1 parameter value
- p2 parameter value

Nothing

No patch. Select this to disable the feature whereby dragging creates a patch.

Spring

$$F = -kp$$

A spring. Pulls the joystick towards the center of the patch, with force proportional to its distance from the center. Some people feel this as a concave surface, or bowl.

Bump

$$F = kp$$

An inverse spring. Pushes the joystick away from the center of the patch, with force proportional to the distance from the center. Some people feel this as a convex surface.

Discous

$$F = -bv$$

Viscosity. Ideally this feels like oil or mud. Due to temporal, spatial, and perhaps force level quantization, it can feel like churning through marbles.

AntiDiscous

$$F = bv$$

Antiviscosity, a non-physical texture. This feels like ice.

ATNSpring

$$F_x = k(J_x - M_x)$$

$$F_y = k(J_y - M_y)$$

(M_x, M_y) is the position of a simulated object, which is incrementally moved towards the joystick position with each frame.

Nap

$$F_x = -bv_x$$

$$F_y = \text{abs}(-bv_y)$$

Null

$$F = 0$$

Bowl

$$F = p * P * \text{sqrt}(\text{abs}[p * P])$$

Wave

$$F_x = -A(\sin p_x / f)$$

$$F_y = -A(\sin p_y / f)$$

Cusp

$$F_x = [\text{abs}(J_x / f) \text{ modulo } (2 * A)] - A$$

Const

$$F_x = v1$$

$$F_y = v2$$

Ridge

$$F_x = k([\text{J}_x \text{ mod wavelength}] - \text{ridgewidth})$$

$$F_y = 0$$

Null

$$F = 0$$

Minus

$$F_x = k(\text{J}_x - \text{M}_x)$$

$$F_y = k(\text{M}_y - \text{J}_y)$$

(M_x, M_y) is the position of the predicted future location of the joystick. The prediction is based on the joystick's current position, velocity, and acceleration.

Circle

$$F_x = k\text{J}_x$$

$$F_y = k\text{J}_y$$

Buckle

$$F_x = v1 \text{J}_x - v2 \text{J}_y$$

$$F_y = v1 \text{J}_y - v2 \text{J}_x$$

Options menu

A grab bag of settings and commands that tune the *Sandpaper* environment and adjust it for different purposes.

Normal

Sets patches from the Texture and Physics menus to display as automatically patterned or animated rectangles, patches from the Arrays menu to display as the height map shaded from a light source that projects to the upper left of the screen (if that shaded array is pre-stored), and patches from the Waves menu to display as black rectangles. See the "Blind" and "Depth" commands.

Blind

Sets patches to display as black rectangles, regardless of patch class. See the "Normal" and "Depth" commands.

All

Depth

Sets Array sampled patches to display as depth maps. See the “Normal” and “Blind” commands.

Square

When this is checked, patches that are created by clicking and dragging in the workspace window are constrained to be square.

DropShadow

When this is checked, a drop shadow is drawn to the right and bottom of patches.

Front

When this is checked, clicking on a patch brings it to the front.

Spiffy

When this is checked, the mouse cursor changes shape depending upon the action that will take place if it is clicked. The table below shows these actions.

:

Cursor	Action	Condition
plus sign	create a patch	cursor is not positioned over a patch, or the shift key is pressed
eraser	delete a patch	cursor is positioned over a patch, and the shift key is not pressed
hand	move a patch	cursor over a patch, and the option key is pressed

Black Background

When this is checked, the background of the workspace window is black, otherwise it is white.

Reset Encoders

For the 3D joystick, reset the coordinate system transform such that the current joystick position is mapped to the upper left corner of screen space.

No Cursor

When this item is checked, the mouse cursor is not shown.

Shuffle Patches

Rearrange the back-to-front order of the patches, and position them using an algorithm that picks random spatial positions, yet attempts to minimize the amount of overlap between patches.

Set Grayscale

Set the color lookup table of the main monitor to a grayscale ramp. The Sandpaper application does this when it is launched, and when it closes dialog boxes, but this command may be necessary if another process acquires the color lookup table resource while Sandpaper is running.

OverDrive

Faster Update Rate. When this is checked, the Sandpaper application is in Overdrive mode. While in Overdrive mode, it doesn't call `GetNextEvent` or `WaitNextEvent` to give time to other processes.

Labels

When this is checked, each patch from the Waves menu is labelled with a randomly generated three-digit number. Numbers are not saved in workspace files, but are regenerated for each patch, for each session.

Beep on Frame

When this is checked, advancing to the next frame in a movie beeps. This is used to aid an experimenter in calibrating written notes with machine state during an experiment run.

Dummy

When this is checked, the joystick cursor on the screen is positioned at a fixed offset from the mouse cursor, instead of from the physical joystick, and no forces are output. This is used for developing *Sandpaper* environment configurations or enhancements while no joystick is connected.

Double Resolution

When this is checked, Array patch surface maps are supersampled by a factor of two (the amount of motion required to move the joystick cursor one pixel on the screen, moves the sample point within the array by two increments). This was a hack used to determine whether increasing the spatial resolution used for force sampling affected the quality of the simulation. The Wave stimuli, which allowed variable resolution, were subsequently added, and were used for this purpose in the experiments.

3 File Formats

Array and **wave** files store information to display the forces and the graphics for patches in the Array menu, and the forces for patches in the Wave menu. **Workspace** and **workspace text** files represent the set of patches in the workspace window, and their ordering. **Movie** files are text files that list a sequence of workspace files, allowing a user to quickly flip between workspaces. **Shuffle** files record the permutations in the order of entries in a movie file when it has been shuffled; this is designed to aid in presenting patches in random order when setting up psychological experiments.

Array format

Array files are arrays of unsigned 8-bit values. The first four bytes of an array file are the width and height, as one-based big-endian two-byte integers. The remaining bytes are the elements of the array, stored in row-major order. Sandpaper signals an error if the size of an array file differs from width * height + 4 bytes.

Array files are used to store both surface maps and visual representations for array-based gradient textures. The numbers in a surface map file are height, where 0 is lowest. The numbers in a visual representation file are luminance, where 0 is white and 255 is black. Whether a file is a surface map file or a visual representation file is encoded into its entry in the Sandpaper source code (the array patch data structure has a field for the filename of the surface map file, and another, optional, field for the filename of the visual representation file). This information is also by convention encoded in the file name — surface map files end in “.depth”; visual representations end in “.shade”. It is not stored in the file data or the file type.

Sandpaper does not look at the file type of an array file.

Wave format

Wave files have the same format as array files, but are used differently within the program.

Workspace format

A workspace file stores an ordered set of patches. It has file type TXPS. Its structure is as follows:

```
byte versionID;
byte sizeof(SandBase);
byte numberOfPatches;
{
    WorldType type;
    // NullType = 0, TextureType, PhysicsType, ArrayType, Wave-
Type
    int         index;
    Rect        bounds;
    int         frame;
    BooleannoStretch;
    unsigned char parameterCount;
```

```
{
    int          whichVar;
    Value        min, max;
    int          sv, smin, smax;
    Boolean      bminf, bmaxf;
} ^parameterCount;
} ^numberOfPatches;
```

Workspace Text format

Workspace text files are a human readable text format with information corresponding to that in workspace files.

Movie format

A movie file is a list of names, separated by carriage returns or newlines. Each name is the filename is the name of workspace file in the same directory as the movie file. File/Open Movie... opens a movie file. There is no facility for creating movie files from within Sandpaper. Movie files have file type TEXT.

Shuffle format

A shuffle file is a list of the form:

```
Movie:<filename>
Date:      <date>
Time:     <time>
[blank line]
<n>    <name>
```

<filename> is the name of the movie file that was shuffled. <date> and <time> are the date and time at the time of the shuffle. Following this header, and the blank line that separates it from the data, is one line for each frame of the movie. Each line is an integer, whitespace, and a name. The name is the name of the workspace file that was at that position in the movie file, after the shuffle. The integer is the index of that workspace file in the original (unshuffled) movie.

Shuffle files are of type TEXT. They are produced by the Options/Shuffle command, with a name that is automatically computed from the name of the movie file and from the current date and time. There is no facility for reading shuffle files directly into Sandpaper.

4 System Characteristics

Requirements

Sandpaper requires an Apple Macintosh™ running System 4.0 or greater, and Color Quickdraw. It runs in a partition size of <> megabytes of memory. (It may require more memory for larger screen size.) It supports the Milliken-Behensky 2D force feedback joystick, and the Russo-Smith 3D force feedback joystick. It can also be used with no joystick, for testing and to recover data saved during previous sessions.

Implementation Limits

maximum number of patches per workspace:	50
maximum number of frames per movie:	100

Appendix C: Qualifier Paper

Question:

The haptic or “touch” sense is considered by many in the human/machine area to be the most complex. Discuss problems and issues in implementing the haptic modality in, for example, tele-robotics or in a simulated “virtual reality”.

Answer Essay:

Why Interface to the Haptic Sense is Problematic

“The hand ... repays its education by enabling the child to obtain the deepest and most practical insight into the structure of things and to penetrate into their innards in a completely different way than with the eye...” [Katz 1925]

The haptic sense is indeed complex. It is a combination of tactile, kinesthetic, and proprioceptive senses. These senses combine with the intentionality that leads a person to explore with the hand and other parts of the body, in order provoke and react to passive stimulation of those senses.

Problems suggested by the characterization above:

1. The haptic senses are *mechanical*. Therefore (aside from the dream of direct neural interfaces) haptic interfaces must have moving parts, or media that change in size, shape or material properties. An interface to the tactile sensors may require small motions, but of many parts, or fast scanning of a mechanical part. Large scale kinesthetic interfaces that can move the whole hand or whole body require large motions and forces. The devices that can do this are hard to design,

build, and modify; suffer from power-size explosive growth, and exhibit mechanical instabilities and sometimes safety problems.

2. The haptic senses are *integrated*. The hand exploring common objects appears to integrate several kinds of information [Ref Lederman 1988]. An unanswered question is: can we use other modalities to substitute for some of the haptic senses (e.g. visual or aural), or is haptic integration thereby destroyed? The haptic system is very poor at certain tasks, such as recognizing 2D shape and size, but is good at integrating its sensing to quickly recognize everyday objects. Each of our current haptic modality technologies can only do limited types of input, or over only a limited range of motion, or over a limited part of the body.

3. The haptic senses make use of *exploratory motions*. In some applications it may be appropriate to constrain the motion or configuration of the body or hand. For example, in learning to read Braille with Optacon vibrotactile array, it does not much matter whether the finger moves or not. However, the subjective experience of whether an object is “out there” depends on exploratory motion. [Kreuger 1989]. For example, two contacts are felt if an object is placed between two fingers, but a single object is experienced if the fingers are squeezed together [William James quoted in Krueger 1989]. The “outside object” experience is essential to the illusions of teleoperation and virtual realities. Thus in most applications we wish to permit exploration. It is difficult to make a general interface that can move and flex and still apply forces and stimuli.

Thus, in inventing interface devices you must both be very clear on *which types* of information must get through, and take advantage of haptic serendipities in using the technologies you *can* create to enhance the sense of presence.

Summary Questions

This poses several questions for haptic interfaces:

What are the most important parts of the haptic sensing system to “talk” to? What is most salient haptically for various tasks? What can we do haptically that is difficult to do with visual and auditory modalities? [What is the haptic “flip side” of the great benefit that a simple click gives in enhancing the sense of object contact when using a visual display? Perhaps it would be adding a simple temperature module to give a sense of what material a computer graphics object is made of? Or might a mass cue be better for this?]

How can we design technologies for these sensing systems?

What body motions or configurations can be constrained while maintaining an illusion appropriate to the task at hand, the local virtual reality?

A Broad Classification of Tasks

In order to answer these questions, we must look at what the user might be doing that benefits from a haptic interface.

While considering examples of force feedback domains for a joint MechE-Media Lab proposal, I came up with the following characterization of activities that could benefit from a haptic interface:

1. Making things
2. Doing things
3. Becoming things

“Becoming things” refers to acting or learning from teleoperation of complete systems, e.g. remote-control submarines, or educational benefits of feeling the world from the point of view of an agent with unusual sensory and effector systems, e.g. an animal. We will not discuss this in this essay.

“Doing things” covers the most of the classical applications of teleoperation - holding a simple end-effector or pincer grip, controlling its 3D position, gripping objects (usually rigid) and fitting them together. Researchers in this tradition have experimented with force amplification and attenuation (usually uniform), scale and rate mappings, and some changes in the overall dynamic regime (your hand is in oil to damp it). At UNC-Chapel Hill, a simulated environment allows you to feel elastic coupling to objects to simulate molecular bonding forces, a form of action at a distance.

The technologies for “doing things” are the best developed. For example, computer controlled robot arms, motor driven and motor-brake force feedback joysticks exist. [A very elegant magnetic technology has just come to my attention...]

“Making Things” Involves Sensing Material Properties - Could Haptic Interface Lead to More Organic Design?

Just as “doing things” suggests manipulating preformed objects, “making things” suggests the kinds of sensations involved in handling materials in order to shape, sculpt, or build things. The MIT MechE Dept. is creating a *virtual workshop* to investigate the concept that intimacy with the process of making objects in the forgiving environment of a computer simulation will lead to better designers and designs. I suggest that a haptic interface could be particularly beneficial here.

One of the overlooked areas in design education is materials. Let's say you are making a hinge on a folding pocket telephone. If you have range of materials to select from, how can you be intimate with the differences between metal hinge like on a cabinet, a leather flap like on a book, or a flexible plastic flap?

Since this is an area where haptic interface can help the designer evaluate the functional and esthetic differences between these materials, we should concentrate on haptic technologies to give information about material properties - springiness, texture, strength.

Control of device physical simulation should be in software.

The inventor of any such device must be ready with a flexible computer control system to implement physics in many ways for the device, to feel what works and what does not. For example, taking advantage of a 2D force feedback joystick to create delicate bas-reliefs and to throw bricks required a flexible software environment in which to experiment. Matching device design to threshold responses of parts of the human haptic system is a way of *guiding* design, but a little bit of haptic interface may go much farther than expected in increasing a system's "realism". Flexible software control of the interface device's physical characteristics is vital to discovering the outer limits of its performance.

Combination Technologies

One approach is to use a general force feedback device, which lets the hand explore grossly, with added special purpose devices attached to give other input directly to the skin, finger joints, and so forth. This requires inventing the special purpose devices. Each invention has limitations.

Example of Design Checking by Match with Physiological Parameters

I will give one example of the kinds of issues involved in design of a specialized device here. Let's consider the idea of using pneumatic inflating pads to give each finger a sense that something may be moving or expanding under it. This device could allow the hand to control environments by using a small part of the range of a grip motion. The "teletouch" is a product [Brodey 1986] that does this, prototypes are able to inflate fully in about 1 sec. The pad inflates 5mm. This rate of 5 mm/sec is well into the normal range for pressure sensation to operate at normal sensitivity (which drops at rates below about .3 mm/sec), but is not fast enough to provide much information to the joints it is moving. [Assuming

that the end finger joint is about an inch long, then the angular displacement of the joint is about 10 degree/sec when pushed by this pad. At this rate, the finger joint motion will not be detected until it has been moved about 2.5 degree [Hall and McCloskey 1983]. This is 250 msec, which is a long time for a control loop.] In other words, this system provides a “real-time” control loop to the pressure sensing system (reaction times of about 160 ms), but a slower than “real-time” control loop to the finger muscle control system. In order to match the human, this device would need to be speeded up (but only by a factor of two). At the moment, we do not know if it is important to trigger joint motion sensing or if pressure sensing is enough for a realistic illusion of an object, say, wriggling with the given amount of displacement.

Harnessing existing technology

A second approach is to see how much material property information can be given through the hand itself, using a general robotic force feedback device. This suggests exploring “volume” and “immersion” material properties. For example, a force feedback joystick held firmly in the hand makes a satisfying probe into regions of varying viscosity. Strength of materials could be probed with the whole hand, giving a sense of how much force is required in various directions to bend or tear part of an assembly.

The tool use metaphor

A third approach is to give the user the strong illusion of using tools, so that their pre-existing expertise with tools and sense of “tool transparency” will allow the illusion of sensing material properties through tools. A force feedback joystick could be fitted with interchangeable handles from real tools, to be used with simulated materials in the “virtual workshop”. I have found that changing hand grip and appearance of the joystick end can radically change alter the perceived nearness of simulated objects to the hand.

Here is a more flexible suggestion for implementing the tool metaphor: Imagine a force feedback joystick with a big ball of putty on top. You grip the putty as you would the tool you want

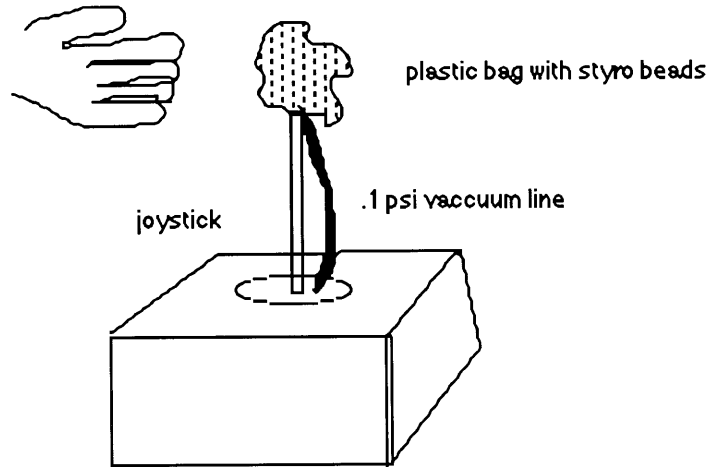

to use at the moment, say a screwdriver or a plane. The putty molds to your hand, and instantly hardens to give you a firm grip on that virtual tool. When you want to change tools, a magic incantation softens the putty. Tools are “furniture for the hand”. In fact, I propose using an architect's invention to implement this effect. I learned from Sean Wellesley-Miller [1975?] that a bag of styrofoam beads can be shaped and then hardened by pulling a light vacuum (.1 psi is enough). A bag of beads could be mounted on the joystick, gripped firmly by the user, and a switch could pull the vacuum necessary to maintain the grippable “tool” shape until re-switched and re-formed by the user.

Teleoperation is Only Part of the Story

This essay has explored issues in using the haptic system as an interface to simulated physical systems. Other major areas for consideration of haptic interface include using physical properties that you can feel as metaphors for other properties has not been explored, for example, you could “display” the size of a Mac desktop folder by its mass. We have also not explored the issues involved

in sparse haptic interfaces, for example, one in which a force feedback joystick might provide little input except occasionally shaking or dragging your hand to get it going in the right direction, or even just to get your attention.

© Copyright Margaret Minsky, 1989