

ON THE DESIGN OF DISTRIBUTED ORGANIZATIONAL STRUCTURES*

by

Pascal A. Remy**
Alexander H. Levis**
Victoria Y.-Y. Jin**

ABSTRACT

The problem of designing human decisionmaking organizations is formulated as an organizational form problem with special structure. Petri Nets are used to represent the organizational form. An algorithmic procedure, suitable for computer-aided design, is presented and the specific algorithms that it includes are developed. The approach reduces the dimensionality of the problem to a tractable level.

*This work was carried out at the MIT Laboratory for Information and Decision Systems with partial support by the U.S. Office of Naval Research under Contract No. N00014-84-K-0519 and by the Joint Directors of Laboratories under Contract No. ONR/N00014-85-K-0782.

**Laboratory for Information and Decision Systems, MIT, Cambridge, MA 02139.

INTRODUCTION

There are two basic problems in organizational design: the problem of organizational form and the problem of organizational control. Most of the theoretical developments in decision and control theory have addressed the latter problem: given an organizational structure, determine the decision rules or strategies that optimize some performance criterion. The former problem has been addressed only indirectly, i.e., given an organizational form, evaluate its performance according to some criteria and then change in some ad hoc manner the organizational form until a satisfactory structure has been obtained. The reason for this approach is that the general organizational form problem becomes computationally infeasible, even for a small number of organizational units.

In this paper, the organizational form problem is posed for a well defined class of organizations - those that have fixed structure and can be represented by acyclical directed graphs. These structures represent distributed decisionmaking organizations performing well defined tasks under specified rules of operation. Such organizations have been modeled and analyzed in a series of papers [1-4]. The basic unit of the models is the interacting decisionmaker with bounded rationality. The set of interactions will be generalized in Section 2 to allow not only for information sharing and command inputs, but also several forms of result sharing between decisionmakers. While this generalization increases the dimensionality of the design problem, it also allows for more realistic models of actual organizational interactions.

The mathematical formulation of the problem is based on the Petri Net description of the organizational structure. Furthermore, the dimensionality of the combinatorial problem is reduced by utilizing the notion of information paths within the organization. A number of new concepts are introduced that bound the problem to the search for alternative organizational forms from within the set of feasible structures only. The introduction of structural constraints, which characterize the

class of organizations under consideration, and of user constraints that are application specific, lead to an algorithmic approach that is implementable on a personal computer. The mathematical model of the organization is described in the second section. In the third section, the various constraints are introduced. In the fourth section, the algorithm is described, while in the fifth a nontrivial example is presented.

MATHEMATICAL MODEL

The single interacting decisionmaker is modeled as having four stages or actions, the situation assessment (SA) stage, the information fusion (IF) stage, the command interpretation (CI) stage, and the response selection (RS) stage. In the SA stage, external inputs -- data from the environment or other members of the organization are processed to determine the situation assessment. This information is transmitted to the IF stage where it is fused with situation assessments communicated by other organization members. The resulting revised situation assessment is used to select a response in the response selection stage. The responses can be restricted by commands received by the CI stage that precedes the RS stage. An individual decisionmaker could receive inputs therefore at the SA stage, the IF stage, and the CI stage. It can produce outputs only by the SA stage and the RS stage. The exchange of information between the situation assessment and the information fusion stages of different decisionmakers constitute information sharing among them. On the other hand, what is being transmitted from the response selection stage of one decisionmaker (DM) to the IF stage of another could be the decision made by the first DM; in this case, the interaction is of the result sharing type. If the transmission is from the RS stage of one to the CI stage of another, then the former is issuing a command to the latter. This interaction imposes a hierarchical relationship between decisionmakers, - one is a commander, the other is a subordinate - while the other interactions don't.

The use of Petri Nets for the modeling of decisionmaking organizations was presented in [3] and exploited in [4]. Petri Nets [5] are bipartite

directed multigraphs. The two types of nodes are places, denoted by circles and representing signals or conditions, and transitions, denoted by bars and representing processes or events. Places can be connected by links only to transitions, and transitions can be connected only to places. The links are directed. Tokens are used to indicate when conditions are met - tokens are shown in the corresponding place nodes. When all the input places to a transition contain tokens, then the transition is said to be enabled and it can then fire. Properties of Petri Nets are the subject of current research, e.g., references [5] - [8].

Figure 1 shows the Petri Net model of the single interacting decisionmaker. The DM can receive inputs (u) only at the SA, IF, and CI stages and produce outputs (y) only by the SA and RS stages, as stated earlier.

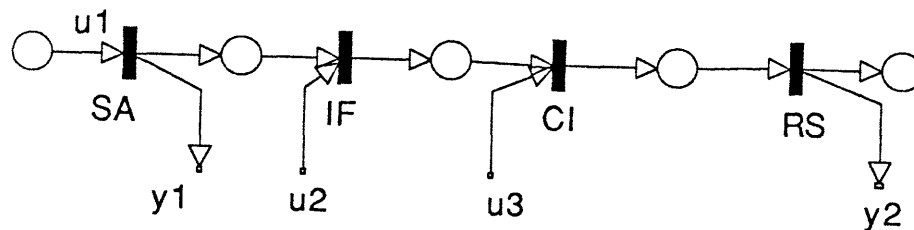

Figure 1. Aggregated Model of Interacting Decisionmaker

The allowable interactions between two decisionmakers are shown in Figure 2. For clarity, only the interactions from DM^i to DM^j are shown. The interactions from DM^j to DM^i are identical. The superscripts i or j denote the decisionmaker; the pair of superscripts ij indicates a link from DM^i to DM^j . Consider the general case of an organization consisting of N decisionmakers, a single input place, and a single output place. The last two are not really restrictions; for example, multiple sources can be represented by a single place and a transition that partitions the input and distributes it to the input places of the appropriate organization members.

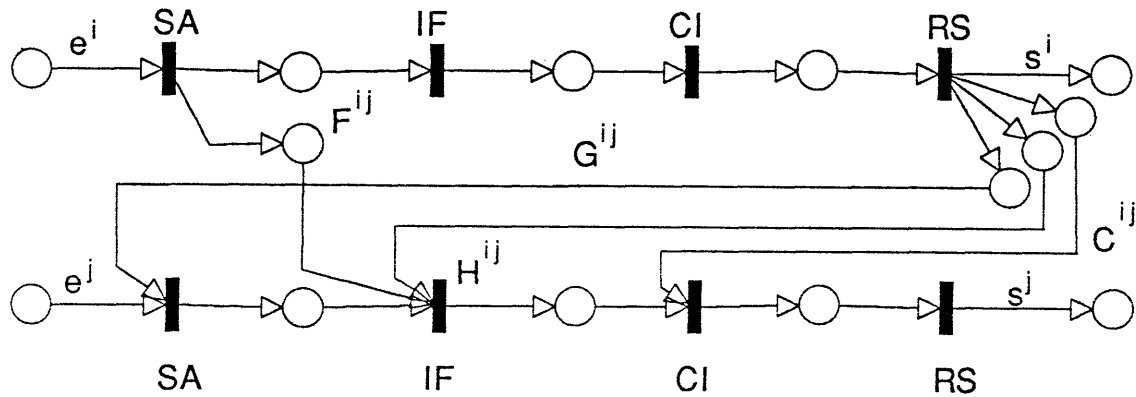

Figure 2. Modeled Interactions Between Two Decisionmakers

The organizational structure, as depicted by the Petri Net, can be expressed in terms of two vectors and four matrices. The elements of these vectors and matrices can take the value of zero or of one; if zero, then there is no connection, if one, then there is.

The interaction between the organization and the external source (input) is represented by an N -dimensional vector \underline{e} with elements e^i . The output from the RS stage to the external environment is represented by the N -dimensional vector \underline{s} with elements s^i .

The information flow from the SA stage of DM^i to the IF stage of DM^j is denoted by F^{ij} . Since each DM can share situation assessment information with the other $N-1$ DMs, the matrix F is $N \times N$, but with the diagonal elements identically equal to zero.

Similarly, the links between the RS stage of a DM and the SA stage of the others are represented by the matrix G ; the links from the RS stage to the IF stage by the matrix H ; and the links from the RS stage to the CI stage by the matrix C . These three matrices are also $N \times N$ and their diagonal elements are identically equal to zero.

Therefore

$$\underline{e} = [e^i], \underline{s} = [s^i] \quad 1 \leq i \leq N, \quad 1 \leq j \leq N$$

$$F = [F^{ij}], G = [G^{ij}], H = [H^{ij}], C = [C^{ij}]$$

$$F^{ii} = G^{ii} = H^{ii} = C^{ii} = 0, \text{ all } i$$

There are, altogether, 2^m possible combinations of different vectors \underline{e} , \underline{s} and matrices F , G , H , and C , where $m = 4N^2 - 2N$. For a five member organization ($N=5$), m is equal to 90 and the number of alternatives is 2^{90} . Fortunately, many of these are not valid organizational forms and need not be considered. In the next section, the allowable combinations will be restricted by defining a set of structural constraints.

CONSTRAINTS

Four different structural constraints are formulated that apply to all organizational forms being considered.

- R_1 The structure should have no loops.
- R_{2a} The structure should be connected, i.e., there should be at least one undirected path between any two nodes in the structure.
- R_{2b} A directed path should exist from the source to every node of the structure and a directed path should exist from any node to the output node.
- R_3 There can be at most one link from the RS stage of a DM to each one of the other DMs, i.e., for each i and j , only one of the triplet (G^{ij}, H^{ij}, C^{ij}) can be nonzero.
- R_4 Information fusion can take place only at the IF and CI stages, consequently, the SA stage of each DM can have only one input from outside of the DM.

The set of structural constraints is defined as

$$R_S = \{R_1, R_{2a}, R_{2b}, R_3, R_4\}$$

The first constraint allows acyclical organizations only. The second and third define connectivity as it pertains to this problem; it eliminates structures that do not represent a single organization. The last two reflect the meaning of the four-stage decisionmaking model.

In addition to these constraints, the organization designer may introduce additional ones that reflect the specific application he is considering. For example, there may be a hierarchical relationship between the decisionmakers that must be maintained in the organizational structure. Then, the appropriate 0s and 1s will be placed in the arrays {e,s,F,G,H,C} thus restricting even further the organizational design problem solution. Lastly, to accommodate some very specific kind of interactions, the organization designer may input links between the decisionmakers that are not modeled by the arrays mentioned above. Those links are however fixed and therefore do not increase the dimensionality of the design problem. They will be referred to as special constraints. Let all these constraints be denoted by R_u .

A Petri Net whose structure can be modeled by the four matrices and two vectors {F,G,H,C} and {e,s}, respectively, will be called a Well Defined Net (WDN). A WDN that fulfills the structural constraints R_s and the designer's constraints will be called a Feasible organization form.

The notion of a subnet of a well defined net (WDN) can be defined as follows: Let W be a WDN specified by the set of arrays {e,s,F,G,H,C}. Let W' be a second WDN specified by the set {e',s',F',G',H',C'}. Then W' is a subnet of W if and only if

$$\underline{e}' \leq e \quad , \quad \underline{s}' \leq \underline{s} \quad , \quad D' \leq F$$

$$G' \leq G \quad , \quad H' \leq H \quad , \quad C' \leq C$$

where the inequality between arrays means that

$$(A' \leq A) \iff (\forall i, \forall j \quad A'_{ij} \leq A_{ij}).$$

Therefore, W' is a subnet of W if any interaction in W' (i.e., a 1 in any of the arrays \underline{e}' , \underline{s}' , F' , G' , H' , C') is also an interaction in W (i.e., a 1 in the corresponding array of W). The union of two subnets W_1 and W_2 is a new net that contains all the interactions that appear in either W_1 or W_2 or both.

DESIGN ALGORITHM

Let R be the set of constraints $R_s \cup R_u$. The design problem is to determine all the Feasible Organizational Forms, $\Phi(R)$, i.e., all the WDNs that satisfy the set of constraints R . The approach is based on defining and constructing two subsets of feasible organizational forms: the maximally connected organizations and the minimally connected organizations.

A Feasible Organizational form is a Maximally Connected Organization (MAXO) if and only if it is not possible to add a single link without violating the constraint set R . The set of MAXOs will be denoted by $\Phi_{\max}(R)$.

A Feasible Organizational form is a Minimally Connected Organization (MINO) if and only if it is not possible to remove a single link without violating the constraint set R . The set of MINOs is denoted by $\Phi_{\min}(R)$.

Consider now the designer's constraints R_u . The well defined nets that satisfy the constraints R_u are denoted by the set $\Omega(R_u)$. For a given number of decisionmakers, the maximally connected net associated with the set of constraints R_u is obtained by replacing all the undetermined elements of $\{\underline{e}, \underline{s}, F, G, H, C\}$ with 1s. This particular net is denoted by $\tilde{\Omega}(R_u)$. Therefore, by construction, $\tilde{\Omega}(R_u)$ is unique.

Proposition 1: Any feasible organization $\Phi(R)$ is a subnet of $\tilde{\Omega}(R_u)$.

Since any element of $\Phi(R)$ must satisfy the set of constraints R_u and

since $\tilde{\Omega}(R_u)$ is the MAXO with respect to R_u , the elements of $\Phi(R)$ must be subnets of $\tilde{\Omega}(R_u)$.

Since $\tilde{\Omega}(R_u)$ is a Petri Net, it has an associated incidence (or flow) matrix Δ , [4]. The rows of the incidence matrix represent the places, while the columns represent the transitions. A -1 in position Δ_{ij} indicates that there is a directed link from place i to transition j ; a +1 indicates a directed link from transition j to place i , while a 0 indicates the absence of a directed link between place i and transition j .

An integer vector g is an s-invariant of $\tilde{\Omega}(R_u)$ if and only if

$$\Delta'g = 0$$

A simple information path of $\tilde{\Omega}(R_u)$ is a minimal support s-invariant of $\tilde{\Omega}(R_u)$ that includes the source node (source place) (for details, see [4]). This simple path is a directed path without loops from the source of the net to the sink.

Proposition 2: Any well defined net that satisfies the constraints R_u and the connectivity constraint R_{2b} is a union of simple paths of $\Omega_{\max}(R_u)$.

Proof: If a WDN \mathbb{T} satisfies the constraint set R_u , then it is a subnet of $\tilde{\Omega}(R_u)$, by the definition of $\tilde{\Omega}(R_u)$. Constraint R_{2b} implies that every node of \mathbb{T} is included in at least one simple path since there is a path from the source to the node and a path from the node to the output node. Therefore, \mathbb{T} is a union of simple paths of $\tilde{\Omega}(R_u)$.

Corollary: Any feasible organization Φ is a union of simple paths of $\tilde{\Omega}(R_u)$.

Let $Sp(R_u)$ be the set of all simple paths of $\tilde{\Omega}(R_u)$, i.e.,

$$USp(R_u) = \{sp_1, sp_2, \dots, sp_r\}$$

and let $\text{USp}(R_u)$ denote the set of all unions of simple paths of $\tilde{\Omega}(R_u)$. From now on, only WDNs that are elements of USp need be considered.

The procedure described so far can be summarized by a sequence of four steps.

Step 1: Given the set of constraints R_u , define the set of arrays $\{e, s, F, G, H, C\}$ that satisfy these constraints.

Step 2: Construct the maximally connected net $\tilde{\Omega}(R_u)$ by replacing with 1s all the undetermined elements in the six arrays.

Step 3: Find all the simple paths of $\tilde{\Omega}(R_u)$ using the algorithm developed by Jin [9] or the algorithm of Martinez and Silva [10] which generates all minimal support s -invariants of a general Petri Net using linear algebra tools. An improved version of this algorithm has been proposed by Toudic [11].

Step 4: Construct the set of all unions of simple paths of $\tilde{\Omega}(R_u)$.

From the corollary, the set $\{\Phi\}$ is a subset of $\text{USp}(R_u)$. Consequently, the number of feasible organizational forms is bounded by 2^r . The dimensionality of the problem is still too large. One more step is needed to reduce the computational effort.

Proposition 3: Let T be a WDN that is a union of simple paths of $\tilde{\Omega}(R_u)$. Then T is a feasible organization form, i.e., $T \in \{\Phi\}$, if and only if, (a) there is at least one MINO which is a subnet of T , and (b) T is the subnet of at least one MAXO.

The MAXOs and MINOs can be thought of as the "boundaries" of the set $\{\Phi\}$. The next step is to find a procedure for constructing the MAXOs and the MINOs corresponding to the constraint set R . Since T is a subset of $\text{USp}(R_u)$, it follows that Φ_{\min} is a subset of $\text{USp}(R_u)$. Then, one can

scan all the elements of USp and select those that satisfy the constraint set R .

To guide the search for MINOs, the links of a net are divided into two categories: fixed and free links. Fixed links refer to requirements that cannot be transgressed and correspond to the 1 entries in the constraint matrices $\{e, s, F, C, G, H\}$ or to the special constraints. Free links correspond to the unspecified elements of the above mentioned matrices: they may or may not be present. Any feasible organization must include all fixed links. Associated with the fixed links are places - therefore, these places are also fixed and must be present in the organization. An index, $hd(p)$ is associated with each fixed place p : it is the number of simple paths containing the place p .

Clearly, if $hd(p) = 1$, the only simple path going through the place p has to be included in all MINOs. It is therefore useless to consider elements of $USp(R_u)$ that do not contain this specific simple path. The scanning of the set $USp(R_u)$ is done by taking advantage of the insight brought by the index hd .

The search process starts by picking from among the fixed places the one with the smallest index hd ; this place is denoted as p_{min} (if there are several such places, one of them is selected, arbitrarily).

Then, one by one, all the simple paths, sp , going through the place p_{min} are considered. For each of them, the remaining fixed places are searched for the one with the smallest index hd . The procedure is repeated until there are no more fixed places.

At each step, an element of $USp(R_u)$ is found and checked against the constraints: if they are violated the scanning stops and returns to the previous step.

If the number of remaining fixed places is zero and if the structural

constraints are not violated, a MINO has been found.

Whenever a MINO or an element of $\cup Sp(R_u)$ violating the structural constraints is found, it is eliminated from the subsequent scanning.

To determine the MAXOs, a similar procedure is used but instead of building the subnets by taking the union of simple paths, the scanning starts from the net $\tilde{\Omega}(R_u)$. Subnets are constructed by removing paths until a feasible form is found. Therefore, the fifth and sixth steps of the algorithm are:

Step 5: Search the set $\cup Sp$ to find the minimally connected organizations.

Step 6: Search the set $\cup Sp$ to find the maximally connected organizations.

Implicit in Steps 5 and 6 is the ability to test efficiently whether constraints R are satisfied. Indeed, if the interconnection matrix (see Ref. [4]) for the net $\tilde{\Omega}(R_u)$ is constructed, then the checking for the constraints R reduces to simple tests on the elements of the interconnection matrix.

APPLICATION

The procedure is illustrated in this paper for the case of a five person organization modeling the ship control party of a submarine. This organization, as it currently exists, has been modeled and analyzed by Weingaertner [12] and is represented in its Petri Net form in Figure 3. At the top of the hierarchy is the Officer of the Deck (DM1) with responsibility for all ship control matters pertaining to the conduct of the submarine's mission. He receives information both from the external environment and from the Diving Officer of the Watch (DM2). He issues command to DM2.

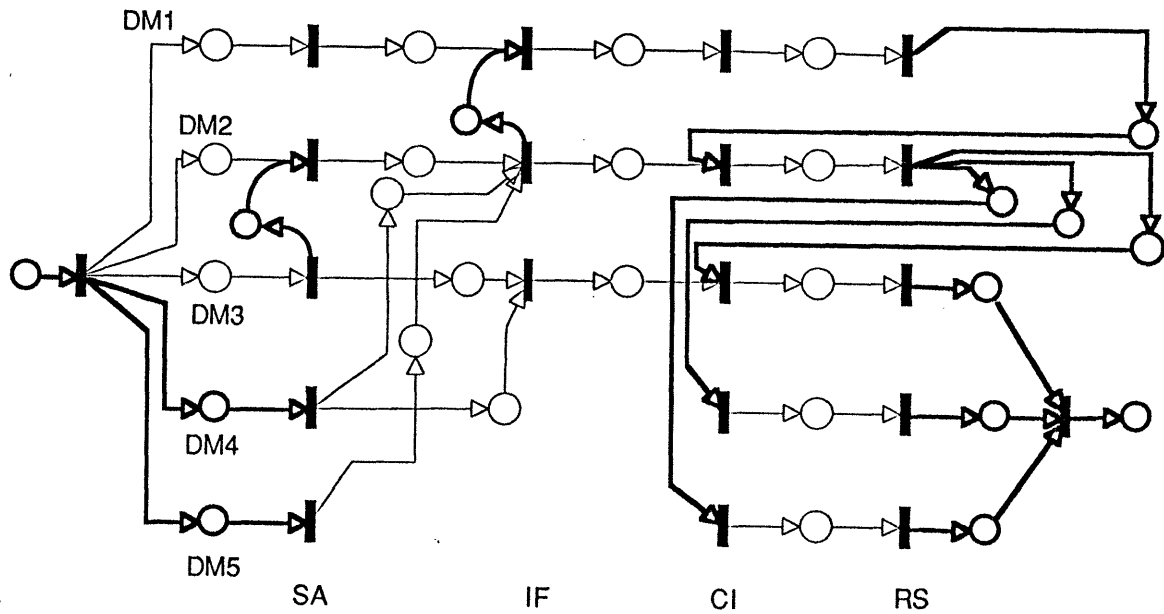

Figure 3. Present Organization

The Diving Officer of the Watch is responsible for the bulk of the control decision process. He receives information from and sends commands to the remaining members of the organization: the Chief of the Watch (DM3), the Lee Helm (DM4), and the Helm (DM5). The decisionmakers DM3, DM4 and DM5 can be considered the sensors and the actuators of the organization. They received information from the external environment (ship control panels,...) and can act on the external environment (stern planes, fairwater planes,...).

The boldface links of Figure 3 represent the fixed links of the organization. They denote the explicit hierarchical structure existing between the members of the organization.

The design problem is to consider alternative feasible organizational forms that could possibly have better performance measures than the actual one. Figure 4 shows the matrices \underline{e} , \underline{s} , F, G, H, C used in the design of alternative organizational forms for the problem under consideration.

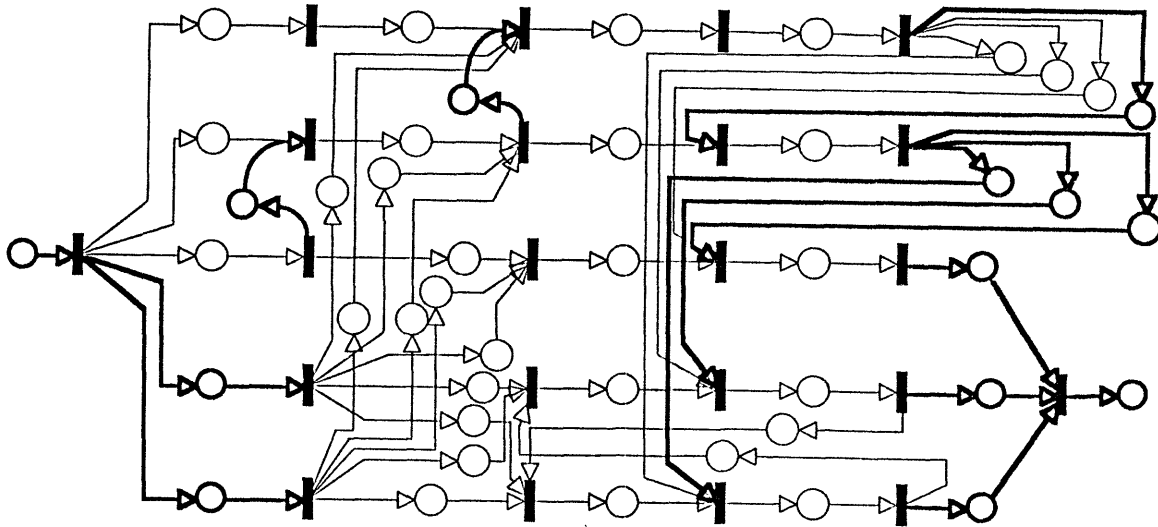

Figure 5. Well Defined Net of Example

The algorithm presented in this paper produces 25 MINOs and 2 MAXOs. For this problem, it took 3 minutes, using Jin's algorithm to find the invariants to determine the complete solution. When Martinez and Silva's algorithm is used to find invariants, the same run takes 7 minutes. One MINO and one MAXO are reproduced in Figures 6 and 7 respectively. They have been selected so that the original organization of Figure 3 is located between them. As expected, the original organization is one specific solution of the design problem. Alternative solutions can be analyzed (see, for example, [12]) to determine preferred designs.

CONCLUSION

The organizational form from problem has been described and a mathematical formulation based on Petri Nets has been presented. An algorithm that reduces the problem to a tractable level has been introduced that takes into account the special structure of human decisionmaking organizations. A preliminary implementation of the algorithm on a microcomputer is described.

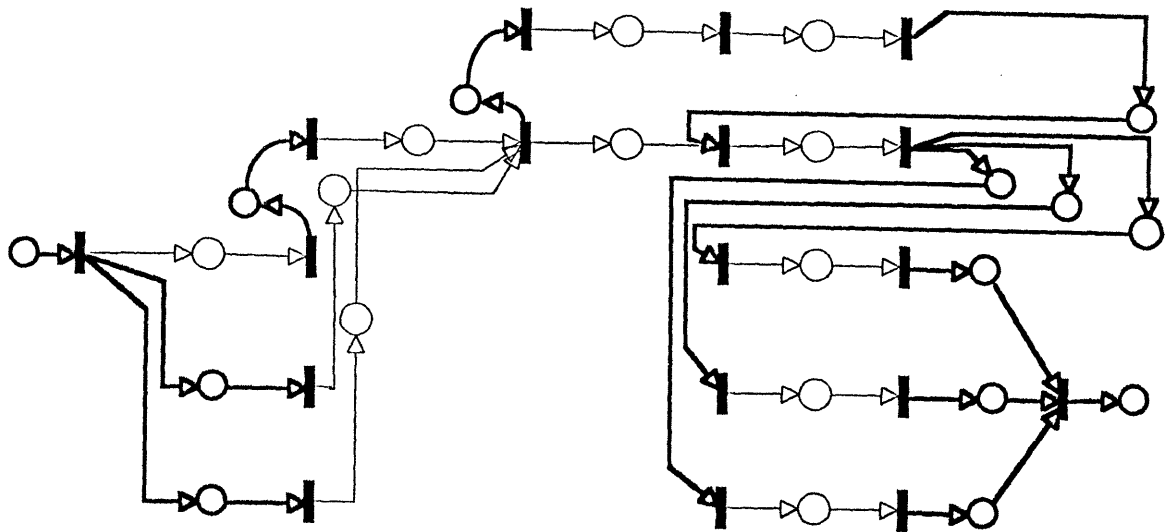

Figure 6. One of the 25 MINOs

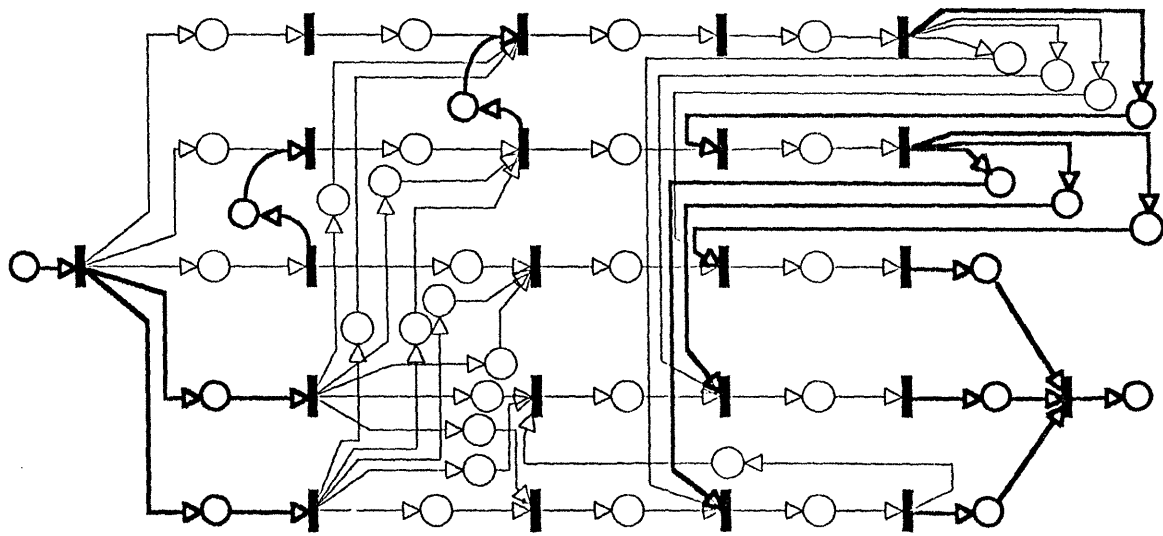

Figure 7. One of the 2 MAXOs

REFERENCES

- [1] K. L. Boettcher and A. H. Levis, "Modeling and Analysis of Teams of Interacting Decisionmakers with Bounded Rationality," Automatica, Vol. 19, No. 5, November 1983.

- [2] A. H. Levis, "Information Processing and Decisionmaking Organizations: A Mathematical Description," Large Scale Systems, Vol. 7, 1984.
- [3] D. Tabak and A. H. Levis, "Petri Net Representation of Decisions Models," IEEE Trans. on Systems, Man, and Cybernetics, Vol. SMC-15, No. 6, November/December 1985.
- [4] V. Y.-Y. Jin, A. H. Levis, and P. Remy, "Delays in Acyclical Distributed Decisionmaking Organizations," Proc. 4th IFAC/IFORS Symposium on Large Scale Systems, Zurich, Switzerland, August 1986.
- [5] J. L. Peterson, Petri Net Theory and the Modeling of Systems, Prentice-Hall, Englewood Cliffs, NJ, 1981.
- [6] G.W. Brams, Reseaux de Petri: Theorie et Pratique, Masson, Paris, 1983.
- [7] W. Brauer, Ed., Net Theory and Applications, Proceedings of the Advanced Course on General Net Theory of Processes and Systems, Hamburg 1979, Springer-Verlag #84, Berlin, 1980.
- [8] G. Rozenberg, Advances in Petri Nets 1984, Springer-Verlag, Berlin, 1985.
- [9] V. Jin, "Computation of Delays in Acyclical Distributed Decisionmaking Organizations," LIDS-TH-1459, MS Thesis, Laboratory for Information and Decision Systems, MIT, May 1985.
- [10] J. Martinez and M. Silva, "A Simple and Fast Algorithm to Obtain all Invariants of a Generalized Petri Net," in Application and Theory of Petri Nets, Giraud C. and Reisig W., Eds., Springer-Verlag #52, Berlin, 1980.
- [11] J. M. Toudic, Algorithmes d'analyse Structurelle des Reseaux de Petri, These 3eme Cycle, Universite Paris VI, 1981.
- [12] S. Weingaertner, "A Model of Submarine Emergency Decisionmaking and Decision Aiding," MS Thesis, Department of Mechanical Engineering, MIT, 1986 (in preparation).