

Underpinning Strategies for Buildings with Deep Foundations

by

Ray Z. Kordahi

Bachelor of Engineering in Civil and Environmental Engineering
American University of Beirut, June 2003

Submitted to the Department of Civil and Environmental Engineering in Partial
Fulfillment of the Requirements for the Degree of
Master of Engineering in Civil and Environmental Engineering

at the

MASSACHUSETTS INSTITUTE OF TECHNOLOGY

June 2004

© 2004 Ray Z. Kordahi. All rights reserved.

The author hereby grants to MIT permission to reproduce and to distribute publicly
paper and electronic copies of this thesis document in whole or in part.

Signature of Author.....
Department of Civil and Environmental Engineering
May 7, 2004

Certified by.....
Jerome J. Connor
Professor of Civil and Environmental Engineering
Thesis Supervisor

Accepted by.....
Heidi Nepf
Chairman Departmental Committee on Graduate Studies

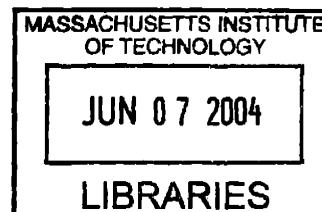

ARCHIVES

Underpinning Strategies for Buildings with Deep Foundations

by

Ray Z. Kordahi

Submitted to the Department of Civil and Environmental Engineering
on May 7, 2004 in Partial Fulfillment of the
Requirements for the Degree of Master of Engineering in
Civil and Environmental Engineering

ABSTRACT

Nowadays, numerous underpinning methods are available to provide safe, fast and practical solutions to nearly any geotechnical problem related to the foundations of a structure. This paper discusses these techniques with an emphasis on grouting and micropiling underpinning systems. Furthermore, some practical case studies such as the current Boston Central Artery Project (Big Dig), where these techniques were adopted, are presented showing the main stages of their construction execution and their main advantages and disadvantages.

Thesis Supervisor: Jerome J. Connor
Title: Professor of Civil and Environmental Engineering

Acknowledgments

I would like to thank a few people for making this thesis and almost everything else this year possible.

Professor Connor, my advisor, for his guidance, motivation and encouragement throughout this academic year.

Lisa Grebner for her support and assistance in the High Performance Project as well as on my thesis.

The department of Civil and Environmental Engineering for its never-ending flexibility, support, understanding and dedication.

Special thanks to my family and particularly to my mom, Dolly, for their continuing love and support throughout my life and especially for making this whole year at MIT possible.

Thanks to all my friends in Boston and Lebanon who never let me forget who I am and who showed me continuous support even in the toughest days.

Finally but most importantly, I want to thank my little brother Albert who always believed in me. I hope you are proud of me and pray that you will always watch over me from above. I love you so much.

Table of Contents:

Chapter 1 Underpinning in General.....	6
1.1-Introduction.....	6
1.2- Preliminary Investigation.....	10
1.3- Underpinning Methods.....	11
1- Jet Grouting.....	12
2- Compaction Grouting.....	14
3- Micropiles.....	15
• Types of Micropiles.....	23
• Drilling Equipments for Micropiles.....	24
• Structural Design of Micropiles.....	25
1.4- Construction Control.....	30
1.5- Recommendations.....	31
Chapter 2 Methods of Design.....	33
2.1- Pre-Design.....	33
2.2- Basic Phases of Design.....	33
1- Micropiles.....	33
2- Bracing.....	34
3- Shoring.....	34
4- New Basements.....	35
2.3- Post-Design.....	36
Chapter 3 Underpinning Cases.....	37
3.1- Pan-Pacific Plaza, Honolulu.....	37
3.2- Addition of Underground Basements, Beirut.....	38
3.3-Saskatchewan Legislative Building.....	45
3.4- Boston Central Artery.....	47
Conclusion.....	53
References.....	54

Table of Figures:

1.	Fig.1 Underpinning of a House.....	6
2.	Fig.2 Underpinning Works.....	6
3.	Fig.3 Shoring Structure.....	7
4.	Fig.4 Temporary Shoring System for Slope Repair.....	7
5.	Fig.5 Temporary Supporting System Made with Micropiles.....	8
6.	Fig.6 Jet Grouting Process.....	13
7.	Fig.7 Jet Grouting Process.....	14
8.	Fig.8 Compaction Grouting Process	15
9.	Fig.9 General Types of Micropiles.....	17
10.	Fig.10 Connection to the Structure.....	18
11.	Fig.11 Construction Stages of Micropiles.....	19
12.	Fig.12 Methods of Underpinning Wall Foundation.....	21
13.	Fig.13 Typical Cross Section of Micropiles.....	23
14.	Fig.14 Percussion Method.....	25
15.	Fig.15 Rotary Drilling Method.....	25
16.	Fig.16 Buckling Modes of Micropiles.....	28
17.	Fig.17 Shoring Process.....	35
18.	Fig.18 General View of Excavation Honolulu.....	38
19.	Fig.19 Cross Section of Building.....	39
20.	Fig.20 Construction Sequence.....	41
21.	Fig.21 Saskatchewan Legislative Building.....	45
22.	Fig.22 Excavation Works.....	46
23.	Fig.23 General View Boston Central Artery.....	47
24.	Fig.24 Step 1 of Underpinning Works.....	49
25.	Fig.25 Step 2 of Underpinning Works.....	50
26.	Fig.26 Step 3 of Underpinning Works.....	50
27.	Fig.27 Inside Tunnels under Red Line Subway.....	51
28.	Fig.28 Step 4 of Underpinning Works.....	51
29.	Fig.29 Underpinning Structure Below the Red Line Subway.....	52

CHAPTER 1: UNDERPINNING IN GENERAL

1.1-INTRODUCTION:

During the last decade increasing needs for construction of multilevel basements, mainly intended to parking space have arised all around the world. Excavations with vertical cuts that may go to depths of 12-15 m necessary for the construction of these basements, have required to perform shoring and underpinning works of existing structures.

Underpinning is a broad term to describe the process of modifying an existing foundation by adding support. This can be done by several methods such as concrete caissons, piles or grouting. Each one has its own advantages and disadvantages depending on the specific characteristics of the project. Different underpinning structures are presented in figures 1, 2, 3 & 4 below.



Figure 1 Underpinning of a House [13]

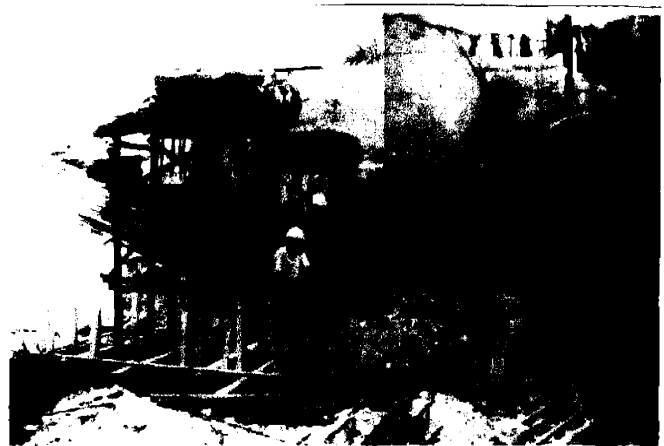

Figure 2 Underpinning Works [14]



Figure 3 Shoring Structure [14]



Figure 4 Temporary Shoring Systems for Slope Repair Project [12]

Furthermore, existing buildings, like historical monuments, sometimes experience excessive settlement under their design load or face the prospect of excessive settlement in the future if a change of building use is required and increased foundation loadings may occur. Several methods of foundation enhancement are available to limit settlements or improve the future performance of existing foundations. One of the common remedial measures for foundations that are settling excessively is to underpin with piles (Fig.5).

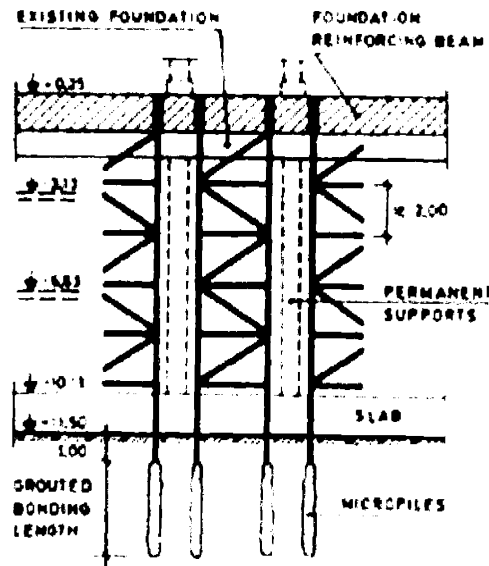

Figure 5 Temporary Supporting Structure Made with Micropiles during Excavation [10]

Various reasons may result in the need for shoring and underpinning. However in general, shoring of a structure is required [10]:

- To support a structure that is sinking or tilting due to poor soil or instability of the superstructure.
- As a safeguard against possible settlement of a structure when excavating close to or below its foundation level.
- To support a structure while making alterations to its foundations or main supporting members.

Underpinning of a structure is required for the reasons above and, in addition:

- ❑ To enable the foundations to be deepened for structural reasons, for example to construct a basement beneath a building.
- ❑ To increase the width of a foundation to permit heavier loads to be carried, for example when increasing the height of a building.
- ❑ To enable a building to be moved bodily to a new site.

Shoring and underpinning are highly skilled operations and should be undertaken only by experienced firms. No one underpinning job is like another and each one must be given specific consideration for the most economical and safest scheme to be worked out. That's why; the improvement and development of underpinning techniques have been growing fast.

Traditional underpinning methods entail large amounts of heavy and unhealthy manual labour. New regulations regarding working conditions and adaptation to ergonomic research results in other branches of the building and construction industries have made the poor conditions on underpinning sites even more unacceptable. For this reason only, new methods were badly needed.

So, a number of methods for underpinning heavy structures have been developed or adapted to these conditions during the last few years.

1.2-PRELIMINARY INVESTIGATIONS:

Before undertaking any scheme of underpinning whether in connection with adjacent construction operations, or to prevent further settlement as a result of ground subsidence or overloading of foundations, it is important to carry out a careful soil investigation by means of boring or trial pits and laboratory tests on soil samples to determine allowable bearing pressures for the new foundations.

If underpinning is necessary to stop settlement, it is essential that the underpinned foundations should be taken down to relatively unyielding ground below the zone of subsidence. The underpinning must be taken down to a deeper and relatively incompressible stratum, if necessary by piers or piles.

If the structure to be underpinned is close to the excavation, it is often convenient to combine the underpinning with the supports to the excavation. The load of the building can then be transferred to the tops of the piles. Alternatively, a system of close-spaced bored piles can be used.

In all cases where underpinning is provided close to excavations, it is important to design the underpinning members to carry any lateral loads transmitted to them from the retained earth or ground water.

1.3-UNDERPINNING METHODS:

Conventional pit method underpinning has been used for centuries. This method consists of enlarging and/or deepening existing foundations by removing soil from beneath the foundations and replacing it with concrete, reinforcement, and a grout material. In some cases the structure is temporarily shored to prevent settlement.

The pit method often results in moderate deformation of the structure and unsafe working conditions. That's why during the last 20 years, several less disturbing methods have been developed to underpin structures that result in much less deformation and a faster, less expensive, and safer operation.

The means and methods of supporting a structure foundation depends on many factors including:

- Foundation loads: static and dynamic; permanent and temporary.
- State of existing foundations.
- Type and magnitude of allowable structural movement i.e.deformations.
- Subsurface soil conditions.
- Subsurface groundwater conditions
- Condition of the structure.
- Access and mobility to the foundations.
- Potential for environmental hazards.
- Seismic loading

This list is by no means exhaustive and each of these factors must be considered in making the evaluation of which underpinning method can best satisfy the project needs.

With the new methods discussed below, underpinning can be achieved not just by load transfer, but also by soil treatment, or by a combination of these two mechanisms. Load transferring methods literally take structural loads and transfer them to an underlying stratum that is more suitable for support. Soil treatments change the physical properties of the ground to make it stronger and more supportive, often without any change to existing foundations. In some cases, ground treatment can be utilized to strengthen the ground while also acting as a load transfer.

Hundreds of examples of underpinning methods exist in the U.S. Each underpinning technology has its own specific soil and loading conditions where its application is most effective. In some cases, constructability can best determine the system to be used. In the sections that follow, I will elaborate on some specific techniques that are mostly used nowadays in typical projects.

1- JET GROUTING

Jet grouting is a load transferring system for underpinning, often also serving as an excavation support and groundwater control system. This is an in situ method of construction undertaken beneath foundations.

Simply stated, high velocity injection of fluids, often enclosed in air, erodes the soils and replaces the soil with an engineered grout, forming a cementitious product known as soilcrete that is capable of attaining unconfined compressive strengths in excess of 1000

psi. Groups of 3 to 4 ft diameter soilcrete columns are constructed to transfer foundation loads to underlying suitable bearing material (Fig.6 & 7).

This technology requires specialized equipment and experience to construct the soilcrete. Work is accomplished safely above grade, and sequenced so that little or no structural deformation occurs. In fact, it is the most widely used system for underpinning historical and sensitive structures.

Jet grouting for underpinning has been applied to construct deep foundation systems, in situ gravity wall structures, and groundwater cutoff barriers.

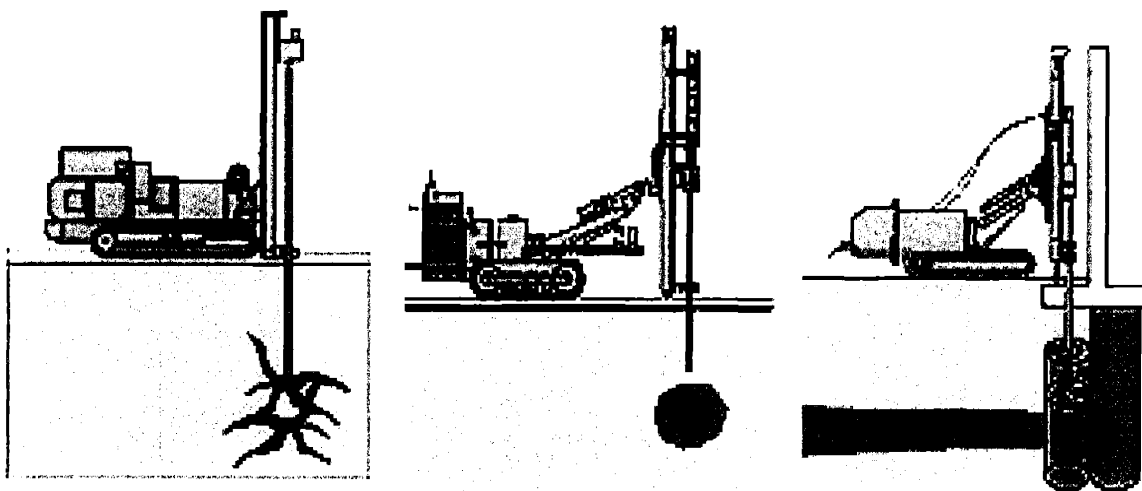

Figure 6 Jet Grouting Process [4]

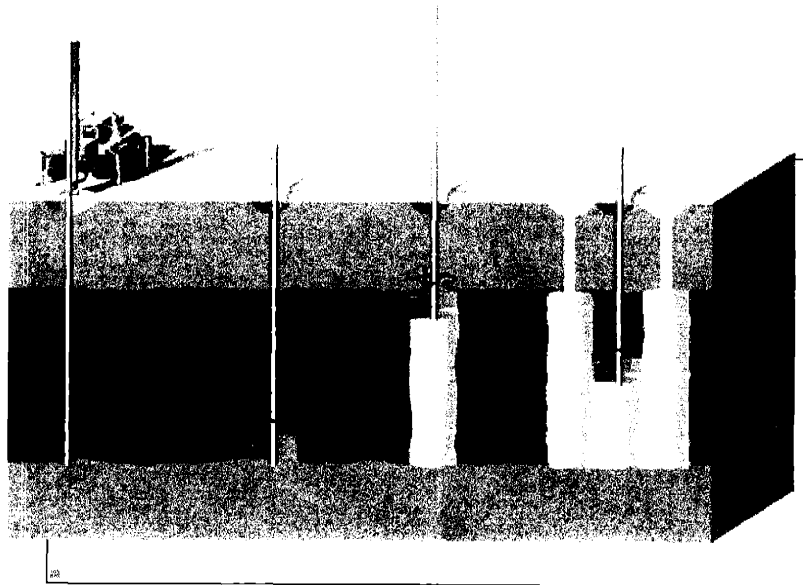

Figure 7 Jet Grouting Process [4]

2- COMPACTION GROUTING

Compaction grouting can be either a soil treatment system or a combination of soil treatment and load transfer. Soil in a loose or soft state can be densified by injecting a very viscous sand-cement grout into these soil zones (Fig. 8). Compaction grouting uses displacement to improve ground conditions. With adequate confinement stress and slow injection rates, the low mobility grout will displace the soil into a denser arrangement, thus increasing its bearing capacity and reducing its compressibility. In cases where ground dropouts are a problem, settled structures can be pushed back to near original position as part of the grout treatment program.

Depending on the location and arrangement of the grout injection and the quality of the cured compaction grout, the grout element can be used as a load transfer mechanism as well as a soil improvement system.

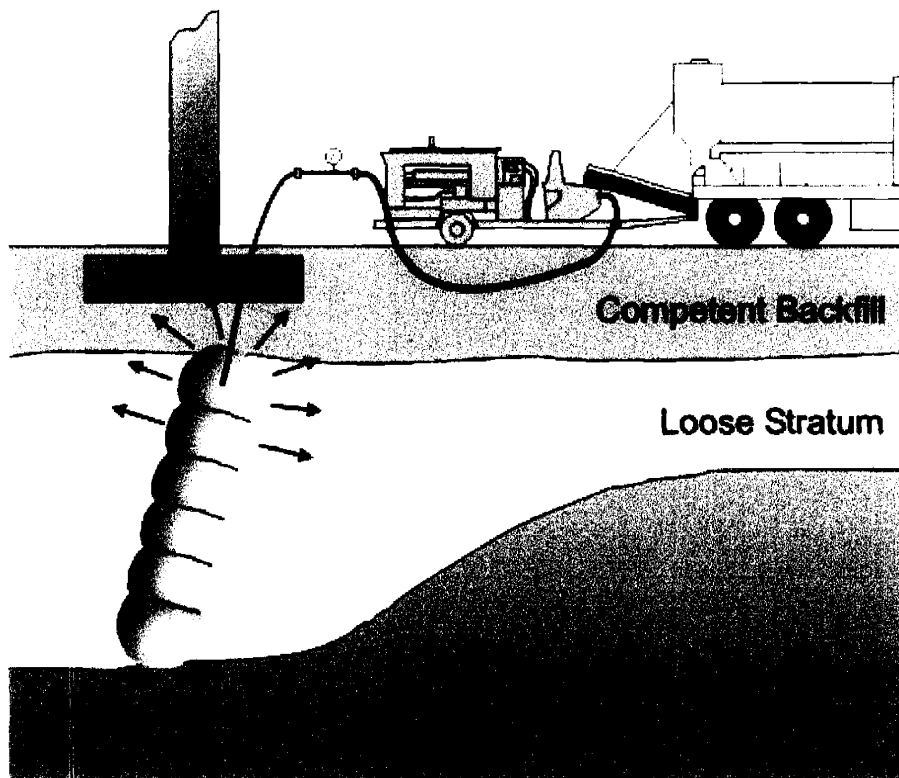

Figure 8 Compaction Grouting Process [4]

3- MICROPILES

Micropiles were developed in Italy in the early 1950's in response to the demand for innovative techniques for underpinning historic buildings and monuments that have endured damage with time.

This type of underpinning is used to stabilize or upgrade existing foundation by installing micropiles through pre-drilled holes determined by loading characteristics.

Micropiles are described as small diameter piles that can be installed in almost any type of soil and that can carry loads up to 500 tons. These micropiles are steel reinforced (a pipe, a rebar or a group of rebars) placed into a small diameter hole and sealed to the ground by grout injections under relatively high pressure.

Micropiles are widely recognized as a common remedial option for underpinning structures having foundation problems after completion or during service period in many countries. Some of the advantages of micropiles are high carrying capacity, less site constraint problems, low noise and vibration and self sustained operation. Furthermore, a major advantage when using micropiles for underpinning is that the system can be designed to have very low settlements. It is common for these piles to develop settlements on the order of a few millimeters or less under working loads. Under these conditions, its bearing capacity is not fully mobilized (Ellis 1985). This piling system is therefore attractive to both the client and the foundation designer. The only disadvantage of micropiles is the relatively higher cost as compared to other piling systems.

“Execution time of a typical small diameter pile foundation carrying loads of 50-75 tons is 1-2 hours including boring and concrete casting” [5].

So in two days, 15 micropile foundations can easily be completed. An equal number of footing foundations take about 1 month to complete!

“Compared to conventional spread footings, up to 50% saving can be realized by the mechanised system producing the small diameter piles” [5].

When working in confined spaces pile elements should preferably be easy to handle and quick to join, demands that lead one’s thoughts to steel piles. However, when using steel, some form of corrosion protection is practically always needed.

In the last few years, micropiling techniques have developed greatly mainly due to the bearing capacity improvement (lateral friction at the bond length) related with the use of high pressure grout injection techniques (bigger than 4 MPa) and high resistance steel hollow tubes. Figure 9 below gives the general types of micropiles used in the construction industry.

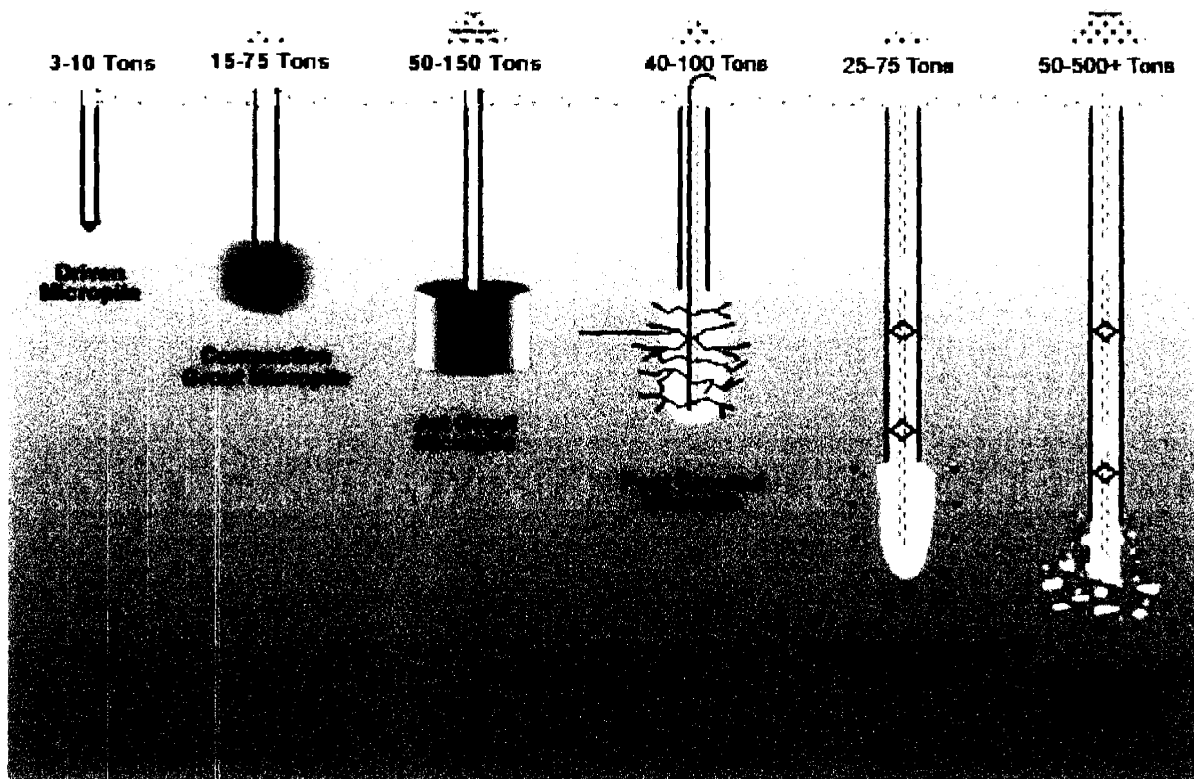

Figure 9 General Types of Micropiles [4]

Also, micropiles can be connected to the structure in two different ways. As described by Mascardi (1982), micropiles can be directly connected to the structure (see Fig. 10). In this case many micropiles are needed, and a high factor of safety against bearing failure results due to the usual settlement restrictions. Micropiles can also be pre-stressed before connecting them to the structure. In this case a few micropiles are used and the factor of safety against bearing failure is lower. In most cases the first option is chosen due to its simplicity. However, in some cases, it is necessary to use the second option to have an acceptable solution. Those cases include when one must limit settlements to very small magnitudes, or have a partial rebound from previous settlements, or when additional basements are to be added.

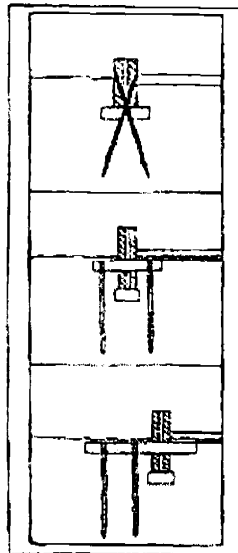

Figure 10 Connection to the Structure [5]

Using drilling and grouting procedures to construct a micropile (Fig.11) induces fewer vibrations and reduces adverse effects to a structure compared with other construction techniques of pile installation. If casing for drilling is used in short segments that can be

screwed together, micropiles can be installed with as little as 1.5 m headroom (Ellis 1985). Bored piles are definitely more used than driven ones since they cause little or no noise and vibration and the piling rig can be operated in conditions of low headroom. In water-bearing sandy soils a careful boring technique is required to prevent sand being drawn into the borehole from the surrounding ground. It is not desirable to pump from the pile shaft before concreting, as this way cause settlement due to “blowing” at the bottom of the pile borehole caused by external water pressure.

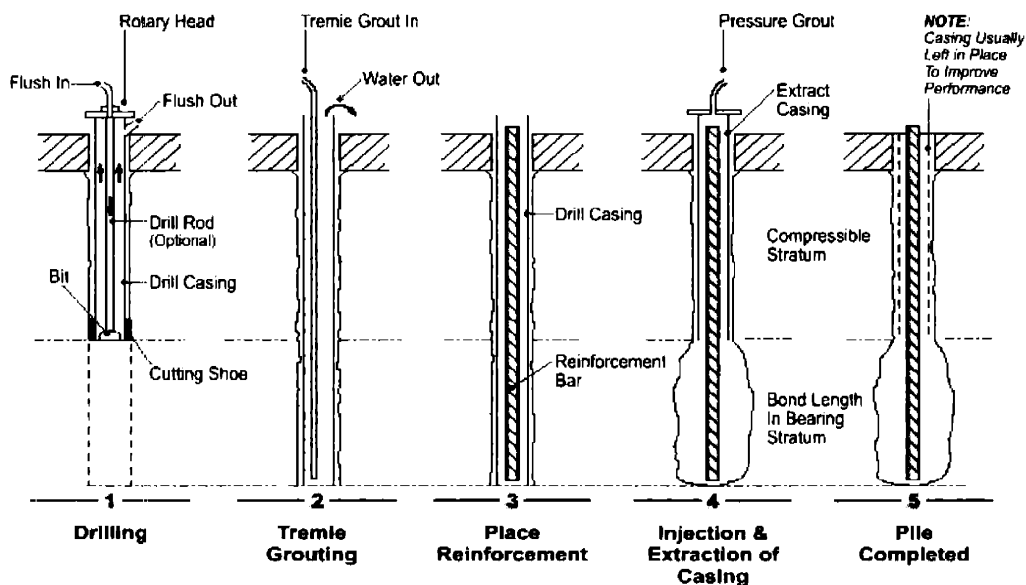

Figure 11 Construction Stages of Micropiles [5]

If it is necessary to transfer load to the pile at a very early age it may be desirable to leave the casing in the borehole or to use universal beams or precast concrete columns inserted

in prebored holes. Steel tube or universal beam piles are useful where bending moments or lateral loads are carried.

In these conditions the holes for the underpinning piles can be drilled through the existing foundations and the reinforcing bars and infilling concrete is bonded to them. The system has the advantage that the work can be carried out from the ground surface and deep excavations to form pile capping beams are not needed. The equipment for installing the piles is suitable for working in confined spaces and the low-frequency vibrations of the drilling machine need not be damaging. The rotary drilling process results in much less loss of ground than conventional drilling by cable percussion methods.

Systems designed to transfer the house weight to new piles should change the original stress distribution in the building as little as possible. Furthermore it should produce as little strain as possible on the building during construction, minimize the need of making holes in the old foundation, often severely damaged. Piles can be installed directly beneath foundations if jacked types are used; when the weight of the building provides the reaction for the jacks. The piles are installed by first excavating a pit beneath the foundation. The bottom pile section, which has a pointed end, is placed in the pit and a hydraulic jack, with steel packing plates and short steel beam sections to spread the load, is used to force the pile into the ground until it is nearly flush with the ground at the bottom of the pit. The jack is removed, the next section is added, and the process repeated until the desirable pile-carrying capacity is reached. Adjacent units are bonded together

by grouting, short lengths of steel tube into the central hole at each stage. When the pressure gauge on the jack indicates that the required pile-carrying capacity has been reached short lengths of steel beam or rail are driven hard between the head of the pile and the existing foundation. The jack is then removed and the head of the pile and packings are solidly concreted.

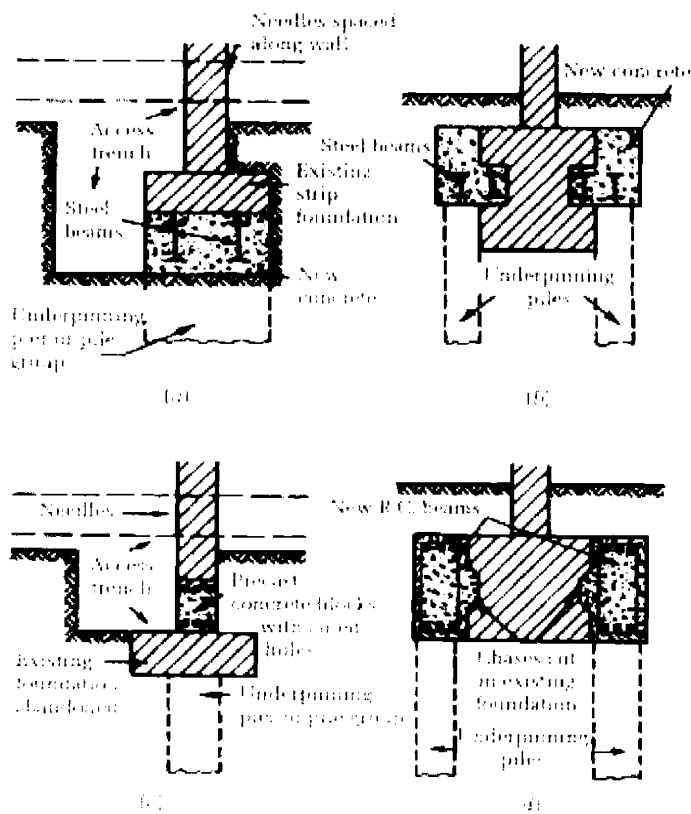

Figure 12 Methods of Underpinning Wall Foundations Using Beams Spanning Between Piles [10]

The pipe piles are usually installed with open ends and the soil removed from time to time to facilitate the entry of the pile sections. If this is not done a plug of soil tends to

consolidate at the bottom of the pile, which greatly increases the required jacking force. On reaching the required level as indicated by the jacking force, the pipes are finally cleaned out and filled with concrete.

When installing jacked piles it is the normal practice to work to a safety factor of 1.5; the jacking force is equal to the calculated working load plus 50 per cent. The final jacking load is maintained for a period of at least 12 hours before the packing is inserted. The adoption of a higher safety factor may lead to excessive loads on the existing structure, although additional weights may be added to increase the jacking reaction.

It is important to insert the packing between the pile and the structure before releasing the load on the jacks. In this way elastic rebound of the pile is prevented and the settlement minimized.

These micropiles have proved to be time saving and economical as foundations in karstic rock containing large clay pockets. Loading tests in continuous rock resulted in large skin friction values. But these values of skin friction for design are reduced when clay pockets exist. Pile buckling (with horizontal subgrade reaction exceeding 1 Kg/cm^3) is not to be expected and therefore high compressive stress is allowed in the concrete. Thus, the piles which are anchored in the rock are satisfactorily stable. The settlements are almost zero. The heave during summertime results from temperature extensions of the piles. But the elastic shortening of these small diameter piles should be considered because it may be the cause of differential settlement.

MOST USED TYPES OF MICROPILES:

Two types of micropiles, namely reinforcement bars system and API (American Petroleum Institution) pipe systems are used (Fig.13). Other types of reinforcements, like H-pile sections, are occasionally used for certain purposes. Figure 11 below, shows the typical sections of micropiles for the two reinforcement systems. “API pipe system is generally recommended for compression piles as it provides good lateral stability of the pile under axial compression load. Reinforcement bars are common for tension piles because of its resemblance with ground anchorage. Some designers also use reinforcement bars for compression piles with provision of sufficient helical links to avoid buckling of reinforcement bars and for piles in ground with good lateral support” [5]. The cementitious grout also contributes to the rigidity of the embedded pile length. Care needs to be taken for micropiles to carry large lateral load or high bending moments because the small pile section will limit the development of sufficient shear and bending resistances. It can be an expensive option for such purpose. The sizes of micropiles usually constructed vary from 100mm to 350mm carrying load of up to 285 Tons respectively.

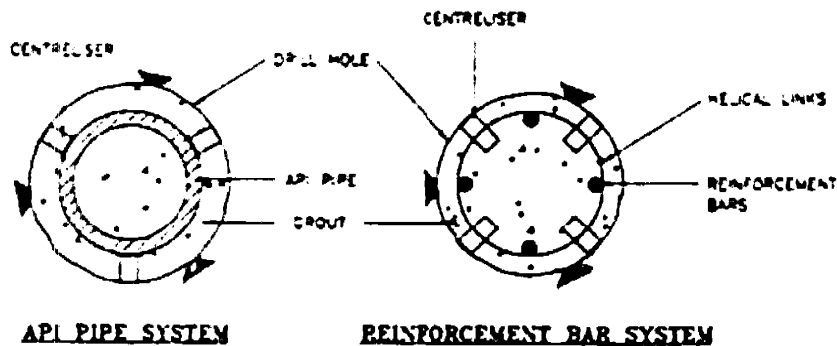

Figure 13 Typical Cross Sections of Two Common Micropile System [5]

DRILLING EQUIPMENTS FOR MICROPILES:

The demands on driving equipment are many. First of all, it should be possible to drive piles through overlying soil to a safe level where the bearing capacity is sufficient. Secondly it should have minimal disturbing effects like noise and vibrations. Thirdly it should be easy to handle in confined spaces and preferably be independent of a counterweight.

New or radically improved earth-drilling equipment specially designed for indoor works has made it possible to underpin houses that were founded on fill that traditional piles could not penetrate. Casing techniques make it possible to install steel core piles to solid rock or to inject steel piles into friction soil.

Two most common drilling techniques used are percussion method (Fig.14) (down-the-hole hammer with high-pressure air flush) and rotary drilling method (Fig.15) (tricone roller bits with drilling fluid). Both drilling methods can be either open hole or casing lined depending on the stability of the drill hole. There are few versions of percussion hammer improved from the original percussion hammer for better performance. The percussion technique has advantages of fast penetration; good verticality and neat working area, but the drawbacks of this technique are vibration and blowing out of excessive earth materials. Therefore, percussion technique is favorable in most site conditions except in sensitive ground with adjacent structures. Rotary drilling technique is almost vibration free and low in noise level but slow in penetration rate, messy workspace and sometime poor verticality. Rotary drilling technique best suits for drilling at sensitive ground and remedial works for foundations under distress.

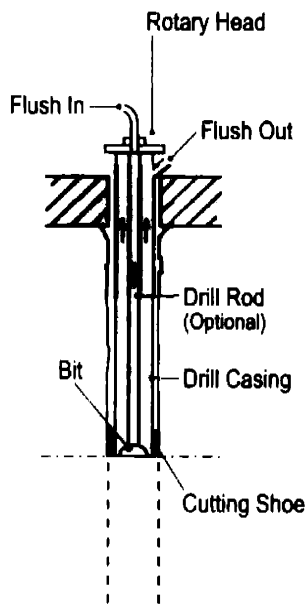

Figure 14 Percussion Method [14]

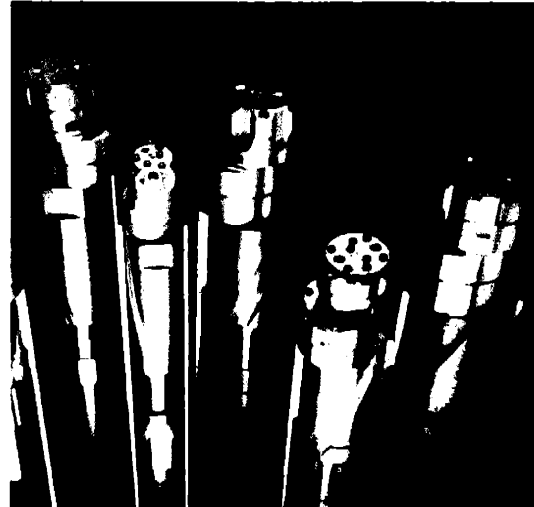

Figure 15 Rotary Drilling Method [4]

STRUCTURAL DESIGN OF MICROPILES [5]:

Micropiles can be designed as rock socketed piles in rock formation and friction piles in weathered rocks or soils to carry either compression load or tension load. All micropiles are designed to transfer load through the shaft friction over a length of pile shaft to the founding medium. End bearing at the pile tip is generally negligible for the reasons of small base bearing areas, in which the axial load can not be effectively transferred to the base. If to be considered, the point capacity commonly does not exceed 15 to 20 % of the side resistance. This design philosophy also inherently demands a founding medium with sufficient thickness to carry the imposed load from the micropile. If there is a cavity below the pile toe or the pile is socketed into a boulder, there will be some transfer of the load to the surrounding sound material by arching effect or to spread the load to the underneath soils. If a large pile group is involved in these founding conditions, care needs

to be taken to avoid punching shear failure of the rock slab or bearing failure of soils underneath the boulder causing excessive settlement under the entire pile group.

The ultimate load which can be supported by a single micropile is defined by the lowest of the following (Mascardi 1982):

- structural shaft resistance
- buckling load
- failure of the grout/ground bond.

The allowable load used is the ultimate load divided by a factor of safety.

However, a lower load may be specified due to limitations of stresses and/or settlements that can be accepted by the structure being underpinned (Ellis 1990).

1. Structural shaft resistance:

The internal capacity of a micropile frequently governs its overall design, because of its small cross sectional area and the large resistance provided by the grout/ground bond due to the construction techniques (Bruce 1994).

The reinforcement steel is the element that carries most of the load. However the load is resisted by both the steel and the grout. It is important to take into account this composite action to optimize the internal pile design. The use of steel pipe or casing as reinforcement elements has become more popular, especially when requiring minimal deflections or supporting lateral loads.

In practice, the design compressive stress in the steel reinforcements is limited to 50% of the yield strength. The pile capacity is normally derived from the allowable structural capacity of the reinforcements in the preliminary design. Other components, such as the grout and additional reinforcement bars can be included to enhance the allowable structural capacity. However extra care is needed to ensure its effectiveness during construction.

The grout commonly consists of cement and water, with water-cement ratios between 0.40 and 0.55. The minimum ratio is set by the requirement that the grout should be fluid enough to allow efficient pumping and injection. The maximum ratio is imposed results because an excessive amount of water would cause bleeding, low strength, increased shrinkage and poor durability. Fine sands can be added to the mix to reduce costs. Sand-cement ratios are limited to 3, but they rarely exceed 1.5. Admixtures are added to modify grout properties: prevent shrinkage, reduce water content, maintain pumpability, accelerate or retard setting, and, prevent bleeding.

2. Buckling:

Mascardi (1982) describes how buckling can be checked by an Eulerian analysis, and shows that micropile capacity is not limited by buckling for most cases. An analysis may be required if the piles are installed through a very soft peaty soil. If the possibility of buckling exists (Fig.16) it can be eliminated by increasing the diameter of the piles or by leaving a permanent casing where required (Bruce 1994). When a portion of the piles has

to be exposed by an excavation, buckling should be considered and the piles may require to be connected horizontally (Mascardi 1982).

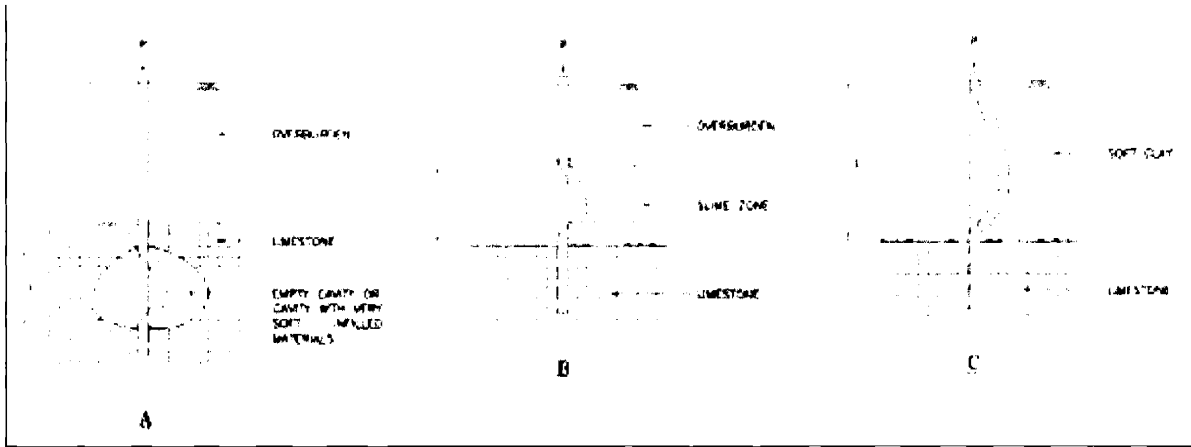

Figure 16 Buckling Modes of Micropiles [5]

3. Failure of the grout/ground bond:

Typically, the load transfer mechanism of micropiles is skin friction. Consequently, the movements required to mobilize the axial capacity of the micropile are small when compared with the ones to mobilize an end-bearing pile because movements needed to mobilize lateral frictional resistance are of the order of 20 to 40 times less than those needed to mobilize end bearing (Bruce 1994). Side friction depends on the grout-ground bond which is highly influenced by the construction techniques and quality. The side friction is improved mainly by three factors as a result of pressure grouting: the increase in the diameter, the increase in the lateral pressure around the pile, and the increase of the

soil strength. For micropiles grouted through a temporary casing, only a minor fraction of the grouting pressure is transmitted to the grout/soil interface.

So in summary, drilled micropiles must be designed to take the required compression, tension, and lateral load applied. This is accomplished by analyzing the pile's structural and geotechnical capacities. The structural capacity of the pile is governed by the grout and reinforcing steel strengths. The typical 4000psi grout compressive strength and 80000ksi steel strengths are multiplied by a reduction factor to arrive at the allowable stresses. The geotechnical capacity of the pile is developed in friction between the grout and the in situ soils.

1.4-CONSTRUCTION CONTROL [5]:

The success of micropiles highly relies on the quality of pile installation particularly the installation method. The construction control is to ensure that a successful pile installation is given as follows:

1. As it is very difficult to determine the rock conditions for every pile, hence, visual inspection on the rock chipping by experienced supervising personnel is useful in determination of the degree of weathering, indicative rock strength, rock mass structures and/or karst features. Recording of the socket penetration rate, and calibrated to the borehole information and the hydraulic pressure applied on the drill shafts can provide indication of rock quality. Change of water level or stabilizing fluid may indicate existence of cavity, solution channels and permeable layer where excessive grout loss is anticipated. Change of hydraulic pressure or sudden drop of drill shaft may also indicate karst features, boulders or hard pans.
2. Measures should be taken to avoid drillhole collapse by means of temporary protection casing or /and stabilizing fluid.
3. Grouting should be carried out immediately after cleaning of drillhole by flushing the drillhole with clean water.
4. Permanent casing can be used to minimize excessive grout loss. Alternatively, using of rapid hardening grout to seal the flow channel could be considered.
5. Proper connection ensuring both ends of the pipes in full contact for coupler and threaded joints and sufficient lapping of reinforcement bars is important to ensure

efficient load transfer between the reinforcement. At coupling or reinforcement lapping, it is recommended to stagger the coupling or lapping to avoid weak section.

6. Centralizers of reinforcements are important elements to assure adequate grout cover for the bonding of interfaces.

7. Excessive welding on high yield steel reinforcement should be avoided as heat can alter the chemical and physical properties of the material.

8. Grease or coating on reinforcement should be removed to ensure good bonding. However, cleaning of the bonding material at the inner surface of the pipes is difficult.

9. Provision of holes should be allowed at the tip of API pipe to facilitate grouting between the drillhole and API pipe.

1.5-Recommendations [5]:

The following conclusions and recommendations are summarized on the applications of micropiles, design aspects, construction methods and control and associated problems.

1. Micropiles can be used as normal foundation piles and compensation piles for remedial works, especially in area with site constraints. Micropiles can be designed as either rock socketed piled or soil friction piles. API pipe system provides good compression performance in terms of lateral stability and vertical increments. Tension piles can be economically reinforced by bars system. Micropiles can be a costly option to support lateral load and huge bending moment.

2. Percussion drilling technique can be applied in most micropile construction except in sensitive ground, particularly in cohesionless soils. In the case of sensitive ground, rotary drilling is highly recommended with temporary casings or/and stabilizing fluid.
3. Factors of safety for both geotechnical and structural designs should be at least two.
4. Buckling load should be checked in soft overburden and very soft and loose cavities.
5. Elastic deformation of micropile is generally large due to high stress utilized on the reinforcements, especially for long piles. Downgrading of pile capacity and additional piles may be required to reduce the differential elastic settlement between the short piles and long piles. Pile group analysis is also required to check the load distribution among the short piles and long piles.
6. Stain compatibility between reinforcements and grout for micropiles in soils should be examined. Suggestions to reduce the elastic strain in the reinforcement by downgrading pile capacity or increasing the steel content for the pile section.

CHAPTER 2: METHODS OF DESIGN

2.1-PRE-DESIGN:

Before beginning the design, the entities below must be known:

- Service, ultimate, and seismic loads applied on the structure especially its columns.
- Position, size and properties of existing footings.
- Values of accepted differential vertical movements accepted by the structure.
- The possible ways to access the upper parts of the building, if there are none, one should be designed.

2.2-BASIC PHASES OF DESIGN:

1- MICROPILES:

The design of micropiles can be done by any of the classic methods but without considering the point bearing capacity, only friction.

Each column must have its load distributed over 4, 6, or 8 micropiles.

The method of geotechnical design will be chosen depending on the soil properties:

In sands, Meyerhof's (1976) and Vesic's (1977) methods are used.

In clay, the α method, the β method and the λ method are all possible.

In fractured rock, Vesic's (1977), Bustamente's (1985), and Littlejohn's (1993) methods in addition to the β method are all usable...

These micropiles are bored in the existing foundation.

Preloading of the micropiles is essential to minimize the settlement effect on the structure.

A new one will be built directly over it; it is designed as a simple foundation on piles.

Structural shaft resistance of the micropiles' sections must be checked.

2- BRACING:

Excavations begin all around and beneath the foundations.

When we arrive to certain level, bracing the micropiles for buckling and horizontal loads must be done

In the case study related to adding a basement to a building (discussed in chapter 3), horizontal loads were not to be taken into consideration because a first basement already existed and its slab could take this load all alone, thus, the micropiles' tips could not move and only buckling was to be considered.

Computing the bracing sections is possible on Finite Element programs like SAP2000.

3- SHORING:

Shoring systems are installed for temporary and permanent earth retention (Fig.17).

Many methods are possible such as sheetpiling, tieback walls with anchors and this is done when excavating near buildings. If not, soil nailing is possible.

Bustamente's (1985) method can be used for computing the diameter and the bonded length of the anchors. And Jewell's (1992) method is used for nails.

The essential difference between soil nailing and tie back walls is that there is little prestress applied to the soil nails, whereas the tieback wall requires prestressing the rods.

The slab itself is designed as a plate with multiple supports, and with Peck's (1963) apparent pressure envelope as load on the slab.

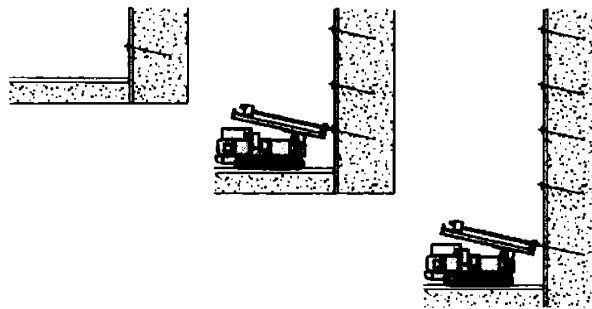

Figure 17 Shoring Process [4]

4- NEW BASEMENTS:

In this phase comes the design of new footings, new columns, new slabs (girders, beams, corbels...), a retaining wall to replace the temporary shoring...etc.

The method of design is classical and known to all.

2.3-POST-DESIGN:

After finishing the basic design steps, their feasibility must be checked and the step by step actions must be known to the workers due to the complexity of the works and to big probability of making mistakes.

CHAPTER 3: UNDERPINNING CASES

In this chapter, different case studies will be elaborated in detail to illustrate the different strategies in underpinning as discussed in the previous chapters.

3.1-Pan-Pacific Plaza, Honolulu, HI [15]:

A combination of tieback sheeting, soil nailing and underpinning was used to support adjacent structures, utilities and roadways for a 56 foot deep excavation in downtown Honolulu (Fig.18). The original underpinning scheme for support of the adjacent Union Plaza structure, which entailed supporting the existing footings directly on bracket piles, was revised in the field when it was discovered that the existing footings were of very poor quality and would not span between brackets. So the revised plan involved constructing a post-tensioned concrete beam below the existing footings and supporting the beam on the bracket piles. This method of underpinning resulted in less than 1/4-inch of settlement for the Union Plaza building.

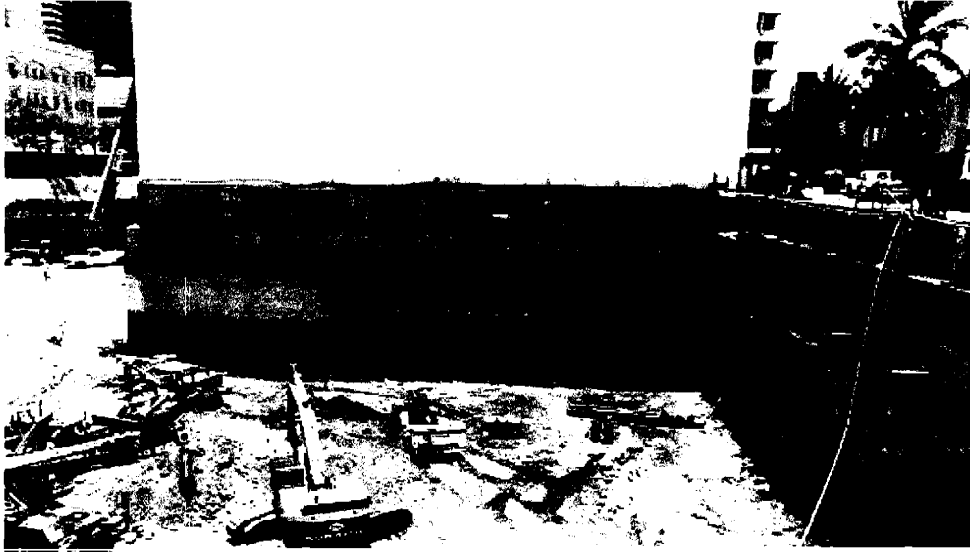

Figure 18 General View of Excavation Works, Honolulu [15]

3.2-Underpinning System Based on Preloaded Micropiling for Construction of Additional Underground Floors,Beirut Lebanon:

INTRODUCTION:

The existing residential building with 7 floors above and 1 floor below ground was founded on individual spread footings in sand (Fig.19).

The structural engineering office, imposed a limitation for differential vertical movement of individual columns and walls in the existing basement of 5mm. This restriction was to be respected for structural reasons throughout the complete building extension and rehabilitation works.

The construction of the new basements was enabled and realized within this limitation by the use of an underpinning system based on micropiles with load transfer system.

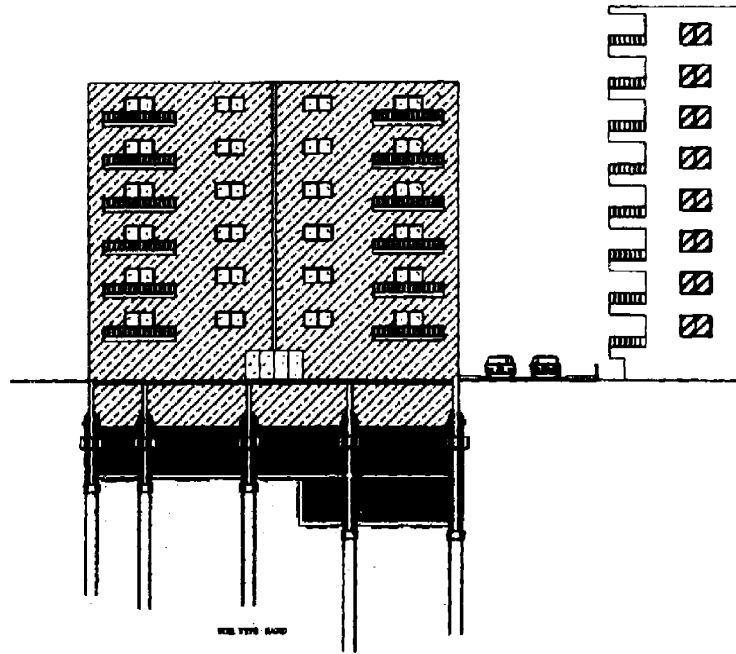

Figure 19 Cross Section of Building

DESIGN:

The total building load was increased from 59300 KN to 80600 KN.

Two load cases were taken into account for the design of the underpinning system:

1. Temporary support of the existing building loads during basement construction stage.
2. Permanent support of the final building loads.

The two load cases had to be handled by the same underpinning system with separate load transfer.

The design combination of both load cases considered a load increment of up to 40% and a shifting of the load centre of columns by up to 25 cm.

The layout of micropiles was determined under consideration of several factors, such as:

- Accessibility for micropile construction
- Column load and load capacity of micropiles
- Eccentricities of column load and pile support for both existing and final load cases
- Symmetry of load transfer by preloading in pairs and restrictions for preloading imposed by existing column dead loads as counter weight.

Under consideration of these requirements and based on available drilling tools and pile tube sizes two types of micropiles were selected:

Type 1: Diameter 150 mm with working load capacity of 680 KN.

Type 2: Diameter 150 mm with working load capacity of 310 KN.

CONSTRUCTION SEQUENCE:

The construction of the new underground floors was achieved in four principal phases as shown in figure 20:

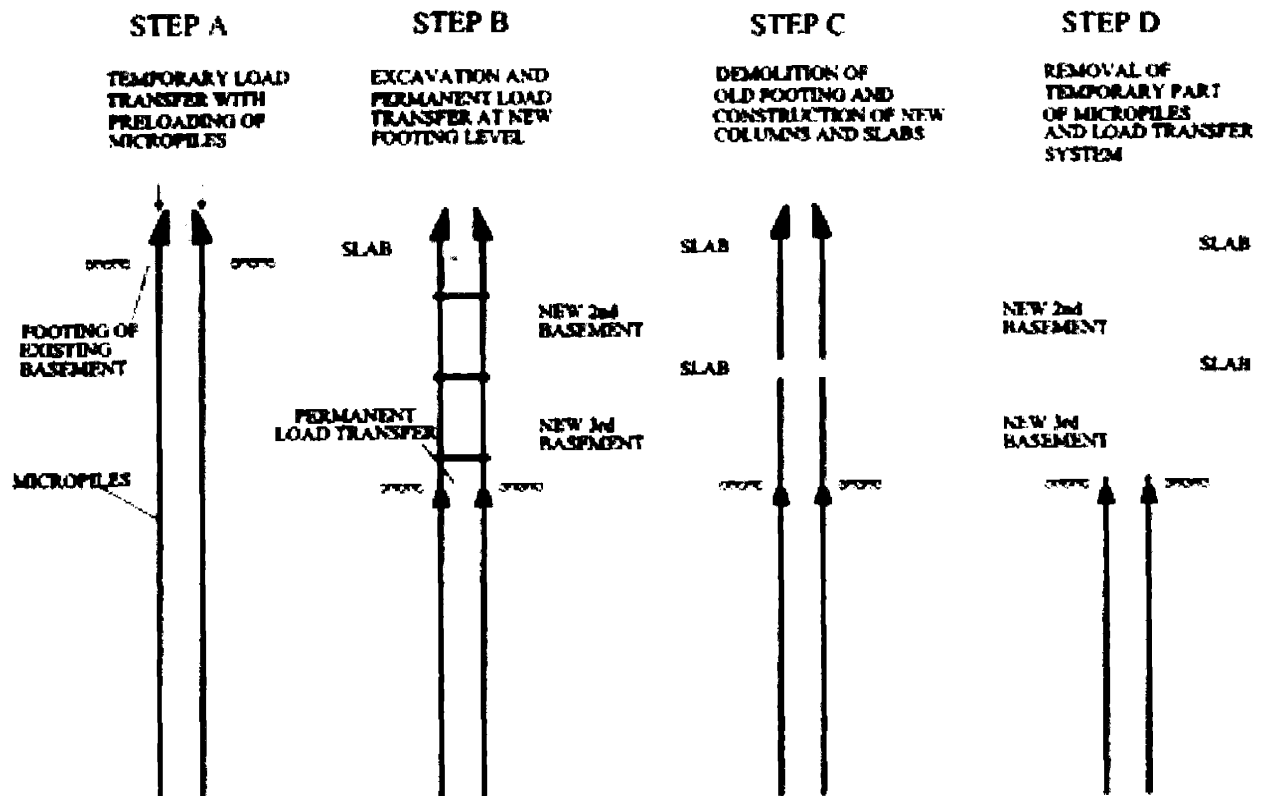

Figure 20 Construction Sequence [courtesy of Bauer Lebanon]

MICROPILE CONSTRUCTION:

The micropile bore diameter was 150 mm produced by drilling 133 mm hollow drill rods and sacrificial cross bits in external water flushing method.

The pile reinforcement was made of seamless steel tubes of diameter 89/74 mm and 73/60 mm, steel grade of 400 Mpa yield, with perfectly square cut ends. The smaller tube was inserted into the larger tube as coupler system and inner reinforcement tube for micropile Type 1, or as coupler only micropile Type 2.

The inner tube was perforated to allow cement grout to penetrate into the gap between inner and outer tube.

LOAD TRANSFER:

The load transfer from columns to the micropiles required to be done before start of excavation in order to activate the support function of the micropiles with all consequential deformations of soil and pile shaft while the building was still resting on its existing footings, thereby affecting the building structure.

The load transfer system was based on preloading by means of hydraulic jacks and fixing of the loads by means of a mechanical device

When the excavation arrived at the final basement level the micropile tubes were exposed and cleaned within the new footing pits and steel rings were added for load transfer between new footings and micropiles.

In the final stage of construction of the footings, columns and slabs in the new basements, the structural connection between the previously existing and the new columns was achieved by injection of the final gap with non shrink mortar. After curing of the mortar the transfer of load from pile heads to the new footings was effected by release of the load in the pile heads.

Subsequently the pile heads including their connection system to the columns and the part of the micropiles above the new footings were removed and all temporary penetrations of columns and slabs plugged.

DEFORMATIONS:

The estimated deformations under existing loads expected during excavation were about 3 mm and under final loads about 5 mm, the actual deformations measured after completion of building works were in the range of 0 to 7 mm and the differential movements between adjacent columns did not exceed 4 mm.

CRITICAL ITEMS ENCOUNTERED DURING EXECUTION OF WORKS:

1. Determination of position, size and properties of existing footings.
2. Determination of existing column loads to perform preloading without pushing up to the columns.
3. Determination of center point positions of new load situation too avoid excentricities under full load and checking of excentricities for preloading under existing load situation.
4. Access for drilling machine, especially at peripheral columns and temporary removal of parts of existing external walls including related temporary shoring.
5. In situ adjustments of many construction details especially for the installation of load transfer systems, including related in situ tests.
6. Coordination of several activities in the restricted basement space, such as breaking and concrete works for structural modifications, i.e. jacketing of columns, construction of new and removal of abandoned columns and girders, micropiling, preparing and fixing of load transfer systems, shoring, excavation, etc...
7. Proper lighting and ventilation of working area.
8. Demolition of existing footing in the course of excavation of new basements was performed by hand held breakers suspended from the ceiling, 3 days to remove footings of 2.5*2.5*0.8 using 2 breakers.
9. Execution time:
 - 3 months for micropiling using 1 nos Huette 200 TF unit.
 - 1 month to fix all load transfer systems

- 10 days to perform preloading under careful monitoring
- 4.5 months to construct 2nd and 3rd basement including all related activities, starting with construction of floor slab of 1st basement.

3.3-Saskatchewan Legislative Building [11]:

Copyright Saskatchewan Archives



Figure 21 Saskatchewan Legislative Building [11]

To stabilize the Saskatchewan Legislative Building (Fig.21), construction crews installed approximately 1,800 piles under the Dome, North, South and East Wings of the structure. Consultants advised Saskatchewan Management team that new foundation supports were required to prevent the building from further shifting and ensure public safety.

To install the nearly 1,800 piles, construction crews needed to gain access directly below the building. An access ramp was built to guide crews directly under the building.

Construction crews excavated earth from under the Dome, North, South and East Wings of the building using bobcats to do a majority of the digging (Fig.22). The excavation below the building occurred in stages. Piles were first installed near the access ramp on the east side of the building. From there, crews worked their way towards the Dome and then to the north and south areas of the building.

Once underground, construction crews installed the pre-cast concrete piles. The piles were installed by hydraulically jacking one-meter pre-cast concrete pile sections into the underlying subsoil. The building's foundation was used as a pressure point for pushing the piles into the earth below. Additional pre-cast concrete pile sections were then added on to the lower section. Jacking continued until the sufficient number of pile sections required to meet specifications were installed.



Figure 22 Excavation Works [11]

3.4-Boston Central Artery:

The Central Artery/Tunnel (CA/T) project in Boston (Big Dig see Fig. 23) is the largest current public works project in the U.S and the most complex highway project in American history. This project requires major cut-and-cover excavation and tunneling for complete replacement of the interstate highway through the heart of Boston. The project's construction plans include underpinning the existing elevated Central Artery structure so that it continues to carry traffic—as well as supporting the railroad tracks leading into the city's main train station—while underground highways are built directly below.

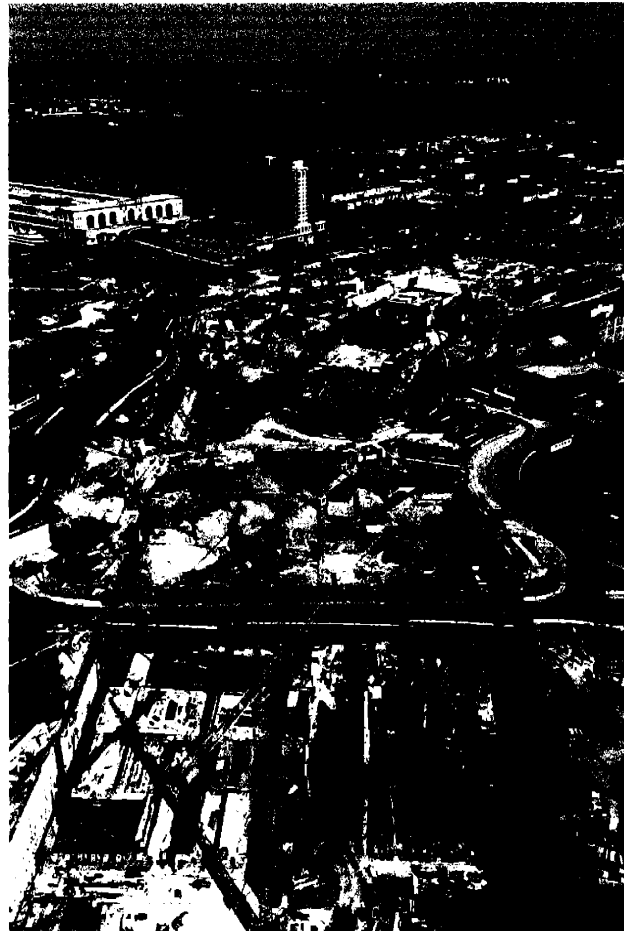

Figure 23 General View Boston Central Artery [12]

This challenging component of the project that consists of underpinning the Massachusetts Bay Transportation Authority (MBTA) Red Line rapid transit underground station at South Station will set this project apart from all the rest.

The Red Line transit must remain in service without interruption while construction is underway. A unique underpinning system was designed and constructed that enabled the contractor to create the 22-meter wide tunnel opening beneath the existing Red Line concrete structure.

So how can they build this subway without interrupting the use of the South Station? “A unique combination of conventional and state-of-the-art technologies, including slurry wall construction, soft-ground tunneling, chemical grouting of soil, deep well dewatering, bottom-up stacked drift mining, and installation of post-tensioned underpinning girders” will be the solution to overcome these challenges.

Since the subsurface conditions imposed challenging design constraints on the underpinning structure, the soil had to be stabilized with grout, before the tunneling work for the underpinning and subsequently the underground roadway could begin.

The underpinning stages of construction will be presented below [14]:

1. Two shafts (A) were dug down to about 20 feet below the bottom of the subway tunnel (see Fig.24). One shaft is on the Federal Reserve Bank corner across from South Station, the other on the old Peter Pan Bus Terminal corner across from One Financial Center. Next, horizontal tunnels (B.), called "grouting galleries," each about 15 feet high, were dug under the subway across Summer Street.

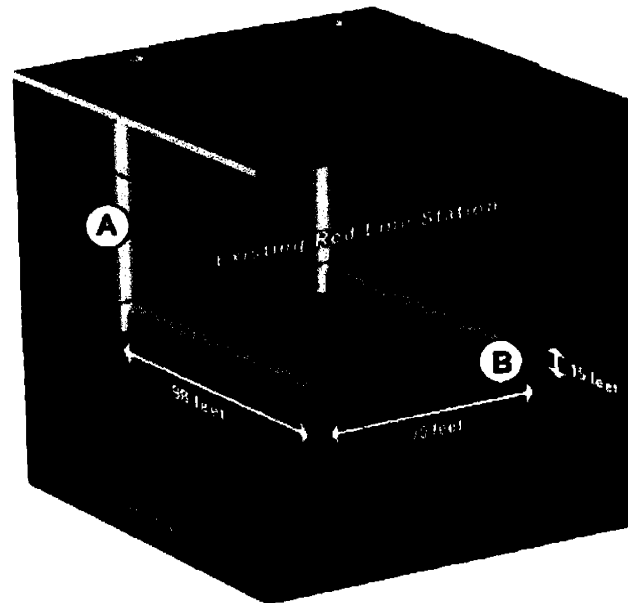
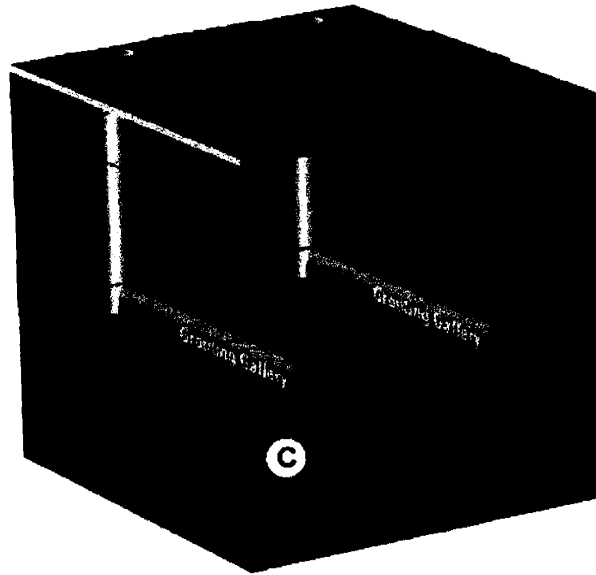

Figure 24 Step 1 of Underpinning Works [14]

2. Then hundreds of small shafts just a few inches in diameter were drilled in a fan pattern (C) from the horizontal grouting galleries down to bedrock about 50 feet below (see Fig.25). Porous pipes were inserted into the shafts and sodium silicate grout material was pumped through the pipes. The grout flowed out the tiny holes in the pipes and filtered through the soil. When dry, the grout makes the soil impermeable to water; tunneling is impossible in water-soaked ground. In fact, to make the first grouting gallery tunnel possible, the entire water table in Dewey Square had to be temporarily lowered by sinking wells to pump out the groundwater.

Figure 25 Step 2 [14]



3. With the grout dry, the vertical shafts could be sunk farther down to bedrock, so that a series of three more pairs of tunnels could be dug, one on top of the next, and filled with concrete (D), forming two massive concrete walls 100 feet long and 45 feet high underneath the grouting galleries and perpendicular to the subway (see Fig.26 & 27). A series of small tunnels (E) between the grouting galleries atop the walls (all filled with reinforced concrete) will form the top of the table. These underpinning girders will be post-tensioned to support the Red Line station.

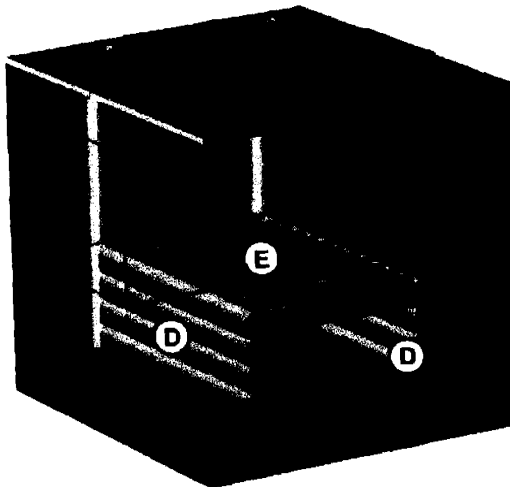

Figure 26 Step 3 [14]



Figure 27 Inside drift tunnels under the Red Line subway at South Station [12]

4. With the soil above the underpinning structure grouted and the structure itself resting on bedrock, the subway tunnel will be fully supported and the highway will be mined between the sides of the "covered bridge" beneath the Red Line (see Fig. 28 & 29).

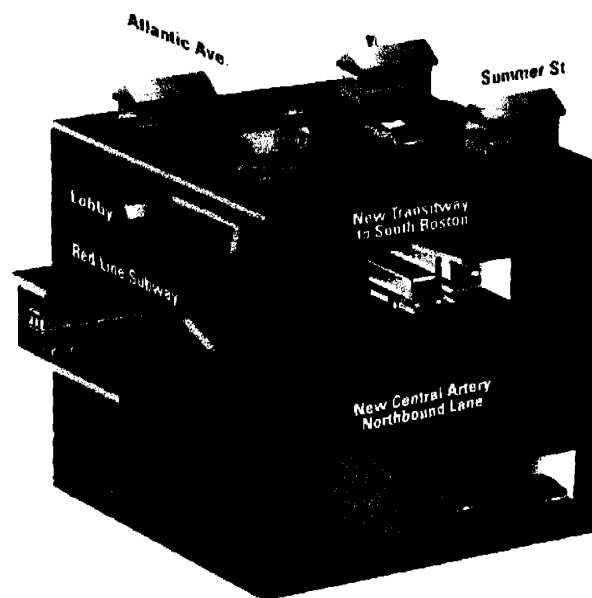

Figure 28 Set 4 [14]



Figure 29 Underpinning structure below the Red line subway, fully excavated and ready for construction of the highway [12]

Conclusion

The demand for underpinning has increased gradually in the last years as renewals and renovation works have gained popularity. As example, the presented cases proved how the versatility of some underpinning techniques can fit the uniqueness and restraints of complex scenarios such as the Big Dig Project where different techniques had to be used simultaneously.

It is also important to point out that underpinning works requires expertise in the design and execution levels, along with safe working practices.

Finally, with the different alternatives available, detailed subsurface information and an understanding of the critical ground performance is fundamental. An experienced geotechnical consultant can offer much to the success of an underpinning system.

References

1. Armour T., Groneck P., Keeley J. and Sharma S. *Micropile Design and Construction Guidelines Implementation Manual*. US Department of Transport, Federal Highway Administration, FHWA-SA-97-070, 2000
2. Burke George. *Underpinning Structures*. Structural Engineer, March 2000
3. GSA. *Design and Construction of a Multi-Drift Subway Underpinning Structure for Boston's Central Artery/Tunnel Project*. Paper No.19-0, November 2001
4. Hayward Baker Services 2003, www.haywardbaker.com
5. Liew S.S. and Fong C.C. *Design and Construction of Micropiles*. September 2003
6. Pinto Alexandre, Ferreira Sandra and Barros Vasco. *Underpinning Solutions of Historical Constructions*. Historical Constructions, Guimaraes, 2001
7. Richardson C. *The Philosophy of Underpinning*. Cathedral Communications Limited, 2001
8. Thorburn S. and Hutchison. *Underpinning*. Surrey University Press, London 1985
9. Thorburn S. and G.S. Littlejohn. *Underpinning and Retention*. Blackie Academic and Professional, London 1993
10. Tomlinson M.J. *Foundation Design and Construction*. Longman Scientific and Technical, London 1986
11. Saskatchewan Property Management Corporation. *Saskatchewan Legislative Building Project: Underpinning*, April 2001
12. www.bigdig.com, 2004
13. www.haleyaldrich.com, 2003
14. www.engineering.com, 2004
15. www.schnabel.com