

EVOLUTION IN THE DESIGN AND CONSTRUCTION OF STADIUMS

by

JAD F. MEZHER

Diplôme d'Ingénieur in Civil Engineering (2002)

University Saint Joseph – Lebanon

Submitted to the Department of Civil and Environmental Engineering
in Partial Fulfillment of the Requirements for the Degree of

MASTER OF ENGINEERING

In Civil and Environmental Engineering

at the

MASSACHUSETTS INSTITUTE OF TECHNOLOGY

June 2003

© 2003 Jad Farid Mezher
All rights reserved

*The author hereby grants to MIT permission to reproduce and to distribute publicly
paper and electronic copies of the thesis document in whole or in part.*

Signature of Author _____ Jad F. Mezher
Department of Civil and Environmental Engineering
May 9th 2003

Certified by _____ Jerome J. Connor, Jr.
Professor of Civil and Environmental Engineering
Thesis Supervisor

Accepted by _____ Oral Buyukozturk
Chairman, Department of Committee on Graduate Students

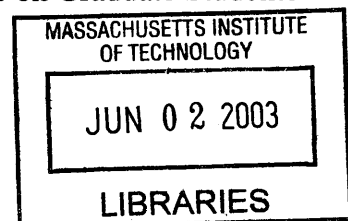

BARKER

EVOLUTION IN THE DESIGN AND CONSTRUCTION OF STADIUMS

by

Jad Farid Mezher

Submitted to the Department of Civil and Environmental Engineering
on May 9th, 2003 in Partial Fulfillment of the Requirements for the Degree of
Master of Engineering
in Civil and Environmental Engineering

ABSTRACT

Stadiums have carried through time, from ancient to modern, a common identity in the design concept, reflected through similarities in shape, structural elements, materials and methods of construction. The earliest design models appeared with the Greeks starting the eighth century B.C. and were improved by the Romans during the first four centuries A.D. The Colosseum, Roman's most acclaimed amphitheater is regarded as the mother of all modern stadiums, setting the rule for innovative design and construction. It generated the first stadium designs of the modern era and guided the evolution of their successors to the level of beauty and sophistication they actually reflect.

This thesis presents the Colosseum as a case study for the identification and analysis of the major aspects of ancient stadiums design and construction methods following the model of Roman Engineering. Moving on towards the last two centuries, the Colosseum will be a guide to trace the evolution in the structural types of stadiums urged by the emergence of new construction materials and techniques in the flow of technological development.

Thesis Supervisor: Jerome J. Connor, Jr.
Title: Professor of Civil and Environmental Engineering

ACKNOWLEDGEMENTS

I am deeply thankful to God for being at M.I.T. and for what I have achieved in this institution.

I want to thank Professor Jerome J. Connor for his guidance, help and support throughout the year, and for his good advice and assistance during my work on this thesis.

I also want to thank Lisa Grebner and Paul Kassabian for assisting me in the “Rehabilitation of Fenway Park” project that was a driving path to my thesis topic.

I want to thank my parents for supporting me financially and morally in order to achieve my goals. I want to thank as well my two brothers Ziad and Ramzi, and my cousin Rita.

Last but not least, I want to thank all my friends in the MEng program. They made the MEng lab a second home for me, with both relaxing and crazy moods. It was nice knowing you all.

TABLE OF CONTENT

<u>ABSTRACT</u>	
<u>ACKNOWLEDGEMENTS</u>	3
<u>LIST OF FIGURES</u>	6
<u>INTRODUCTION</u>	8
<u>CHAPTER 1 ANCIENT STADIUMS</u>	10
1.1 INTRODUCTION	10
1.2 ROMAN AMPHITHEATERS	12
<u>CHAPTER 2 OVERVIEW OF THE COLOSSEUM</u>	14
2.1 DESCRIPTION	14
2.2 THE FOUNDATIONS	17
2.3 STRUCTURAL OVERVIEW	19
2.4 CANOPY OVERVIEW	21
<u>CHAPTER 3 ROMAN CONCRETE</u>	24
3.1 INTRODUCTION	24
3.2 TYPES AND PROPERTIES	25
3.3 CONCRETE WALLS	27
3.4 CONSTRUCTION PROCESS	30
<u>CHAPTER 4 ROMAN ARCHES AND VAULTS</u>	31
4.1 INTRODUCTION	31
4.2 VOUSOIR ARCHES	33
4.3 CONCRETE ARCHES AND VAULTS	35
<u>CHAPTER 5 WORKFORCE AND CONSTRUCTION</u>	38
5.1 INTRODUCTION	38
5.2 BUILDING REGULATIONS AND CONTRACTS	41
5.3 THE WORKFORCE	42
5.4 MACHINERY AND CONSTRUCTION OF THE COLOSSEUM	43

SECTION II

<u>CHAPTER 6 MODERN STADIUMS</u>	<u>46</u>
6.1 INTRODUCTION	46
6.2 MODERN CONCRETE	48
6.3 MODERN STEEL	49
6.4 THEY LOOK THE SAME	50
6.5 CANOPY FOCUS	50
6.6 OVERVIEW OF CURRENT ROOF STRUCTURES	53
6.6.1 Air –supported	53
6.6.2 Cable supported structures	54
6.6.3 Retractable Roof structures	55
<u>CONCLUSION</u>	<u>56</u>
<u>GLOSSARY</u>	<u>57</u>
<u>REFERENCES</u>	<u>58</u>

LIST OF FIGURES

<u>Figure I</u> : Greek and Roman Stadiums	11
<u>Figure II</u> : Roman theater and amphitheater at Arles, France.....	12
<u>Figure III</u> : Colosseum vaulted ambulatories.....	13
<u>Figure IV</u> : Roman Colosseum	14
<u>Figure V</u> : Colosseum section and façade view.	15
<u>Figure VI</u> : Roman Colosseum.....	16
<u>Figure VII</u> : Colosseum plan dimensions	16
<u>Figure VIII</u> : Colosseum foundation;section and elevation view	18
<u>Figure IX</u> : Colosseum elevated section view	19
<u>Figure X</u> : Support buttresses for arches	20
<u>Figure XI</u> : Colosseum canopy	21
<u>Figure XII</u> : Canopy cables and pulles	22
<u>Figure XIII</u> : Roman currency.....	22
<u>Figure XIV</u> : Colosseum model with the cover masts.....	22
<u>Figure XV</u> : Support bollards.....	23
<u>Figure XVI</u> : Masts supports and sockets.....	23
<u>Figure XVII</u> : Roman wall types.....	28
<u>Figure XVIII</u> : Roman bricks.....	28
<u>Figure XIX</u> : Opus reticulatum	29
<u>Figure XX</u> : Roman bricks.....	29
<u>Figure XXI</u> : Opus testaceum	29
<u>Figure XXII</u> : Opus testaceum	29
<u>Figure XXIII</u> : Opus incertum.....	29

Figure XXIV: Roman scaffolding.....29

Figure XXV: Wall construction30

Figure XXVI: Foundation wall formwork30

Figure XXVII: Primitive arches.....32

Figure XXVIII: Voussoir arch.32

Figure XXIX: Forces in a voussoir arch.....33

Figure XXX: Distribution of forces from a voussoir arch.....34

Figure XXXI: Destabilizing forces in a voussoir arch34

Figure XXXII: Colosseum axiometrics view36

Figure XXXIII: Relieving brick arches in the concrete vaults37

Figure XXXIV: Concrete vaults in the Colosseum ambulatories.....37

Figure XXXV: Reconstruction drawing of the chorobates43

Figure XXXVI: Reconstruction of the groma44

Figure XXXVII: Roman winches used for the construction of the Colosseum44

Figure XXXVIII: Colosseum ambulatories.....45

Figure XXXIX: Vault centring45

Figure XL: Berlin stadium51

Figure XLI: Colosseum canopy52

Figure XLII: Modern canopy52

Figure XLIII: Membrane of the Silverdome.....53

Figure XLIV: Stade de France cable roof.....54

Figure XLV: Miller Park’s retractable roof55

INTRODUCTION

Since the beginning of their existence in the ancient Roman Empire, arenas and amphitheatres were the center of attraction in any city, especially in the capital Rome. Some of them were very enormous and really magnificent and they were made to last “forever”. They are still a center of attraction even in our current days because of their architectural beauty and innovative structure. For their construction the emperors used to call for the finest engineers to erect a structure that would not fail or wither but would last indefinitely in a sign of their might and of the Empire’s. In working on the projects, the engineers put all their knowledge and the contractors all their abilities to build lasting and efficient stadiums. The many examples of Roman arenas, still standing after many centuries, spread all around Europe and the Mediterranean are solid evidence of Roman ingenuity in stadium design and construction.

In our current days, the concept of might behind the construction of beautiful and structurally amazing stadiums, shifted from an Emperor's need, to take place between competing architects and engineers. The requirements for efficiency and cost effectiveness however remain the same. As for the attraction that these structures bring, it never changed. Stadiums are still some of the most magnificent and innovative structures.

Their construction was made possible through ancient times because of the techniques developed and the materials invented that currently might sound advance for that period of time. The techniques and inventions in the design and construction kept on going through the ages until now, and it is clear what level of advancement they have reached. To understand the evolution in the design and construction of stadiums, a look back on the most famous stadium of the Roman Empire is a must.

“Despite the natural hazards and the messing that was done to the structure that destroyed part of it, the Colosseum still retains its power and beauty and is justifiably regarded as the “mother of all stadia”. It has served as a model for countless modern stadia and remains a potent source of inspiration for today's stadium builders” ([1], p40)

Even though the Greeks discovered the virtues of many engineering innovations before the Romans, they did not quite use them for their sports facilities. Their stadiums were just an idea of U shaped playground graded in a hill, on which stone sloped seating was placed for the best viewing. In the field of stadium design as well as many other structures not discussed in this thesis, the Romans bypassed the Greeks with the improvement of the techniques they inherited from different sources as well as the creation of their own. The Colosseum is one of their most well done stadiums that integrated all their ingenuity and defined the rules for innovative design and construction. The aspects of stadium design and construction as well as the materials used to erect them in the ancient and current times will be discussed. The major part of this thesis is however historical and will focus on Roman engineering and the Colosseum.

1.1 Introduction:

The origin of stadiums dates back as far as the eighth century B.C with the Greeks, who invented in 776 B.C the first competition games and which later became the Olympics. The stadiums were either laid out in a U-shape cut in a hillside so the seats would be formed naturally, or constructed on flat ground. Stadiums constructed on flat ground can be found in Olympia and Athens, where the first Olympic games in the modern time were held in 1896.

As the Romans invaded all the surrounding regions of the Mediterranean, they integrated in their society pieces of the cultures of the people they ruled. From the Greeks they took their love for social entertainment and their stadiums and developed them to the specifications of their needs. The most famous of the Roman stadiums is the Colosseum which was erected to host bloody shows of fighting and whose construction was completed in 82 A.D.

All parts of the Roman engineering were integrated in the construction of this marvelous stadium, from the use of stone and concrete arches as well as concrete vaults as structural elements, to the use of pulleys and wheels as support for the canopy and winches.

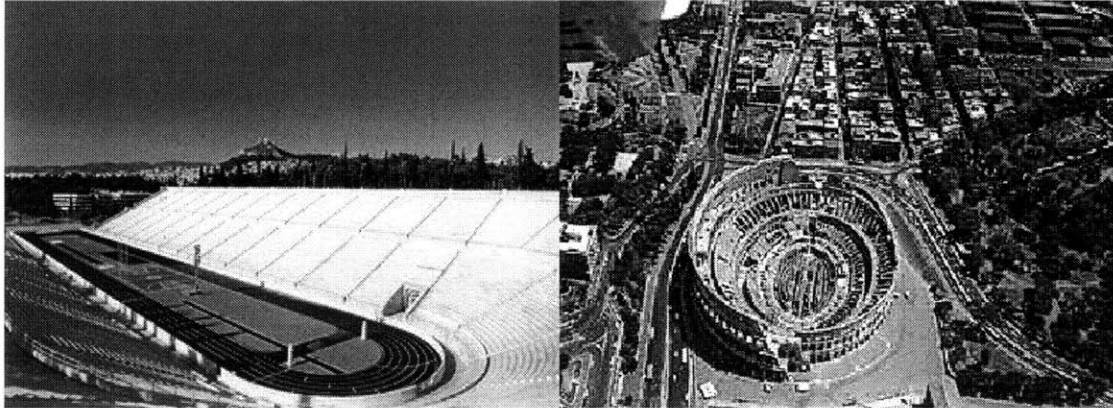

Figure I: Greek and Roman Stadiums

After the fall of the Roman Empire and the rise of Christianity through Europe, the Olympic games in Greece and bloody fighting in Rome were banned as a pagan rite and the emphasis of the society shifted to the construction of churches until the revival during the industrial era.

In the industrial era, the return to the stadiums as a place for entertainment gatherings began with the rehabilitation of ancient stadia, such as was done in Athens for the Olympics of 1896. However, the need for new stadiums grew with the increase in the number of games that were invented and of the fans attending them. With the improvements brought to the ancient iron industry and the invention of the Portland cement, a breeze of revolution in structures design and construction began to blow. Stadiums started to be constructed out of simple concrete or steel columns and beams until they arrived to the level of sophistication we see today with the use of new materials such high strength concrete and steel among others.

There is as direct line that stretches between the construction of the first stadiums in Greece and their development in the Roman Empire until the modern times [g].

In the ancient world, the Colosseum was from an engineering point of view, the most advanced stadium ever constructed. It symbolized the maturity reached in stadium conception and erection. For that matter, it is not entirely wrong, to focus only on this marvelous structure, in the attempt to understand ancient stadium design.

1.2 Roman amphitheaters:

To accommodate the public displays of mortal combat, the Romans developed an *amphitheatrical*¹ form for their *arenas*². For them an amphitheatre was a place for action where spectators don't really need to hear, as in the case of theatres, but rather needed to see. Going out from the layout of Greek theatres that were relatively small spaces with a stage and the audience seated on one side of it, the Romans had the intuition of combining two theaters and turn them into the much larger amphitheater.

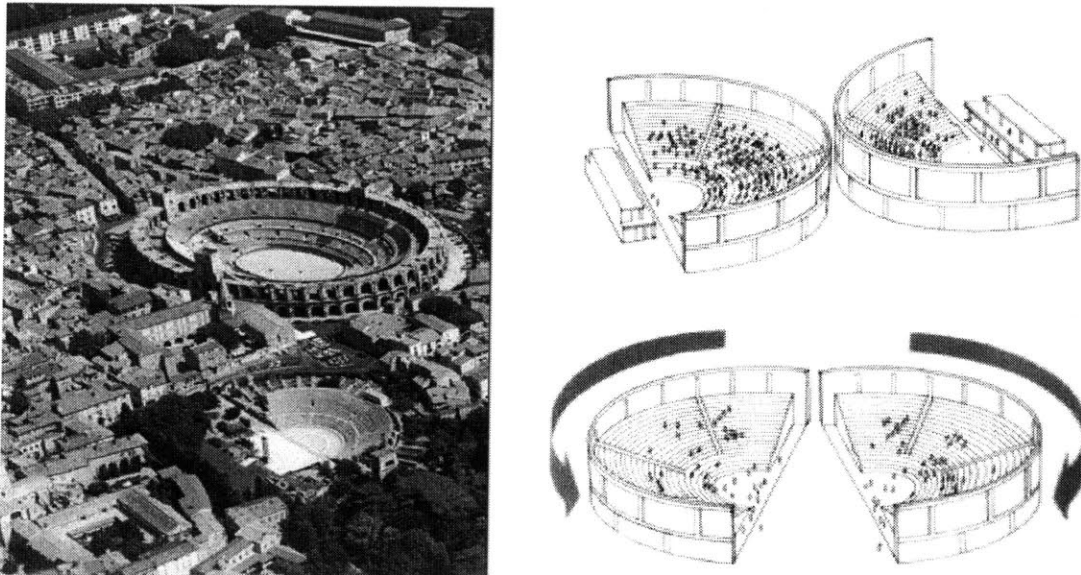

Figure II: Roman theater and amphitheater at Arles, France

Unlike the Greek stadiums where the seats did not circle the whole play ground, the Roman amphitheater was a near *elliptical*³ shape with an arena in the center surrounded by seats on all sides, in order to accommodate the maximum number of spectators. The seats were constructed as high-rising tiers, so the spectators could have a clear view of the events staged before them. The number of stories ranged between two and four depending on the elevation needed for the best viewing and the number of spectators the structure was supposed to host. Two-stories Roman amphitheaters can be seen at Arles (Figure II) and Nimes in France. The Colosseum, which was the biggest amphitheater in the Roman Empire, is the only one with four stories.

As the Roman amphitheaters were constructed on flat ground, they did not rely on natural ground slopes to provide the necessary seating profile but rather on artificial slopes. The *architectus*⁴ had to construct these slopes using materials available at that time such as timber, stone and concrete, and structural intuition, which the Romans were famous for. This intuition enabled them to further push the use of arches in the construction of aqueducts as well as in public buildings such as the Colosseum.

Their ingenuity also improved the quality and properties of the mortar with the invention of hydraulic concrete, called Roman concrete, whose reputation is still acclaimed today. Roman concrete was of a high strength and its use shifted from a bonding agent or plaster to a structural material similar to its use in our current days. This innovation allowed Roman engineers to overcome the disadvantages of stone construction and explore new architectural forms allowing longer spans and clearer spaces underneath.

Vaulting, which can be seen in the corridors of the Colosseum, is an example of these forms. (Section 4.3)

Figure III: Colosseum vaulted ambulatories

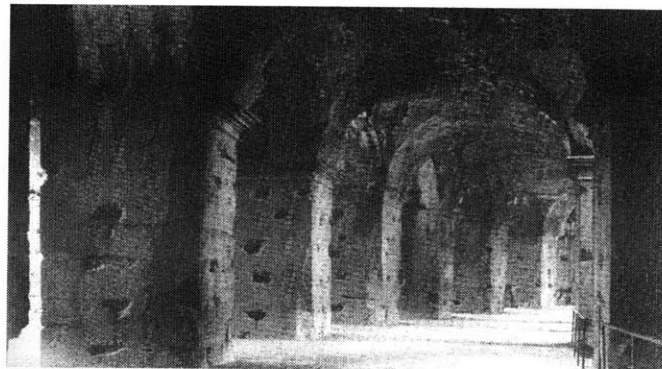

"While the Coliseum stands, Rome shall stand; when the Coliseum falls, Rome shall fall;
when Rome falls, the world shall fall." [a]



Figure IV: Roman Colosseum

2.1 Description:

The pseudo-elliptical shaped Amphitheatrum Flavium or the Colosseum in Rome is the largest and best-known building of the Roman antiquity. The construction of the 160 feet high wonder of the Roman Empire, which started in 72 A.D, took ten years to be completed. Covering six acres, the near 2,000-year old stadium could accommodate 50,000 spectators, a stadium capacity that would not be exceeded until the twentieth century ([g], p5). The long axis of the ellipse is 188 m long, the short axis 156 m, and the whole perimeter is 527 m (Figure VII)

The building is oriented along the NW to SE axis, and it stands on the site of Nero's Golden Palace former lake, which was drained before the construction. The foundation consists of a massive twelve meters deep ring made out of concrete and huge travertine⁵ stone blocks. The structure was mainly made out of concrete with the use of other

materials, such as travertine for the pillars and wall facing, brick for wall facing and marble for the seating but that have long disappeared due to looting.

The building stands on a base of two steps over which three floors of arcades were constructed and surmounted by a fourth story called *attico* pierced with rectangular openings. It is believed that the existing upper level was not part of the original design but then was added during the construction, which ended in 82 A.D. Each of the lower three floors originally had eighty arches separated by pillars constructed with large blocks of travertine. The blocks were bonded together by the mean of metal clamps, which have long since disappeared, while their corresponding holes still remain visible.

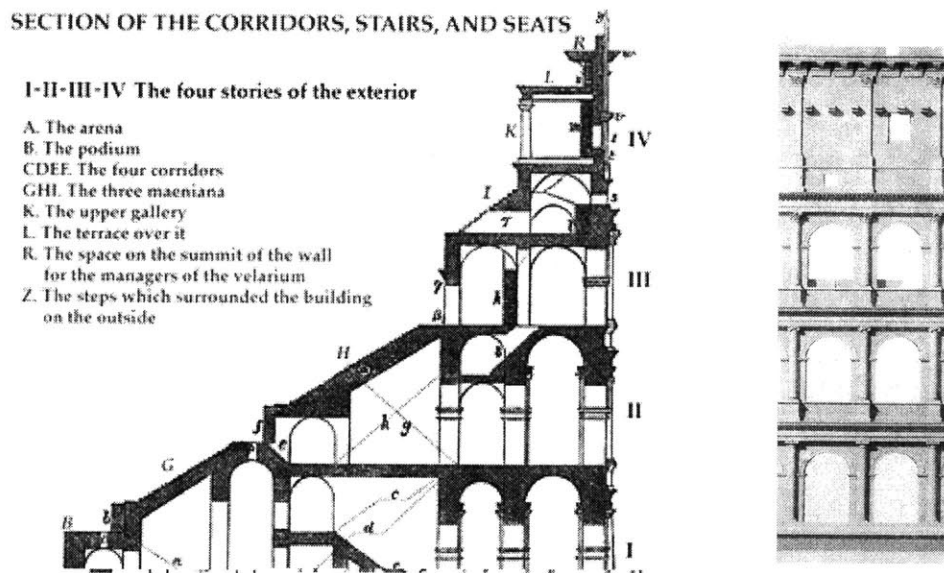

Figure V: Colosseum section and façade view

The facade was made out of travertine, radial walls out of travertine, tufa⁶ and opus cementicium (concrete with small aggregates of tufa), the other walls out of a combination of different materials such as tufa, brick and opus cementicium and the vaults out of cement cast with bricks for the facing or for relieving the weight (Chapter 4).

Around the arches of the exterior wall, are framed non-structural three quarter columns and entablatures for the ornament. The four arches on the axes of the building were the

main entrances and the other 76 arches were numbered to simplify the access. The overall 160 feet height and slope gradient of 37° for the seat tiers, raised 11'8" above the arena, were calculated to give a good view to all the spectators. Upon entering the Colosseum, visitors climbed sloping ramps to their seats, according to gender and social class. The corridors and stairs were planned in order to allow the public a swift access and exit, estimated to just 15 minutes for the full evacuation of the stadium. The two main entrances on the short axis led directly to the central boxes while several concentric ambulatories led the other spectators to their assigned places.



Figure VI: Roman Colosseum

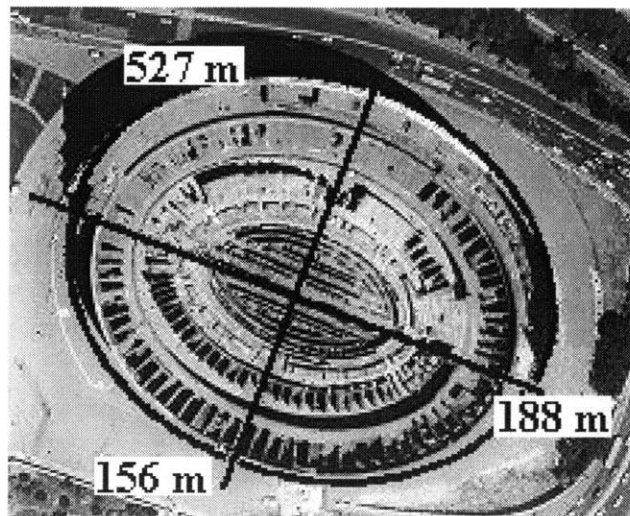

Figure VII: Colosseum plan dimensions

2.2 The Foundations:

It is believed that one of the major elements in the long life of Roman structures rely on their foundations. The Romans understood that the biggest threat in what comes to soil behavior is not when the foundation sinks uniformly under the buildings load, but when the soil is inadequate and settles differentially causing the structure to crack and distort. They realized that reaching a consistent soil giving, more or less an even resistance to settlement would be the best solution for the problem. Regardless how deep it was, they tried to reach the bedrock, as it is the ideal case, or a firm layer of clay or gravel as they considered it suitable for any type of structures, even very heavy ones [d].

The soil under the Colosseum consists of several meters deep layers of sand and silt over layers of clay. During the work on the foundation, the layers of sand and silt were excavated until the clay could be reached. When the firm layer of clay was reached an elliptical ring of 31 meters wide, 6 meters deep and with a perimeter of 530 meters was also excavated. The ring was then filled with concrete and huge travertine stone blocks. Another 6 meters deep layer of concrete and stone block was poured over the first one in order to achieve a twelve-meter thick massive concrete mat.

Brick walls, 3 meters thick and 6 meters deep, were built as reinforcement along the inside and the outside of the ring shaped foundation [2]. Roman engineers understood that the massive foundation was needed to hold the enormous weight of the amphitheater, reduce the differential settlement and minimize the bearing pressures by spreading the loads over a wide area.

In addition they knew that the soil would settle and level itself to a great extent under the weight of the huge foundation before the construction of the structure.

What also helped is the subsoil that was pre-consolidated under the weight of the lake, before it was drained, enabling them to have a firm layer of clay. This approach in the construction of the huge mixed concrete-stone footing was crucial to maintain a stable platform for the erection of the stone arches and walls, used in the Colosseum.

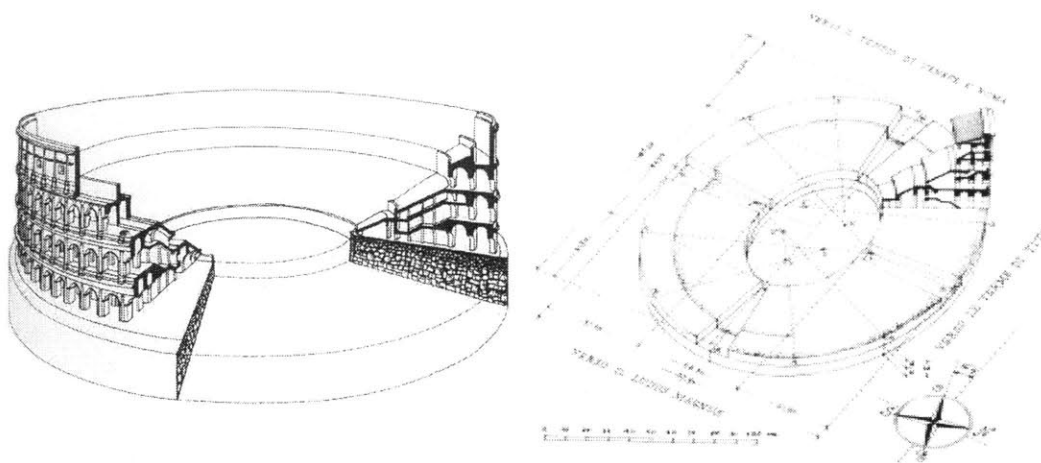

Figure VIII: Colosseum foundation; section and elevation view

The combination of both concrete and stone in the construction of the foundation was to increase its strength and resist the enormous weight of the structure as well as to keep it as much monolithic as possible through the bonding action of the concrete. As Romans knew about the water proofing quality of concrete, it is not wrong to think it was a major they pushed its extensive use in the foundations. This property was a very important issue in the early days of the Colosseum; when the amphitheater used to be filled with water for mock naval battles. The water was diverted to the arena from the Tiber River, running not far from the stadium, through four passageways constructed in the huge foundation ring (Figure VIII, Right). The concrete prevented the water from leaking to the substructure and causing damage.

2.3 Structural overview:

"...like a vast mass of rock."

Hans Christian Andersen [b]

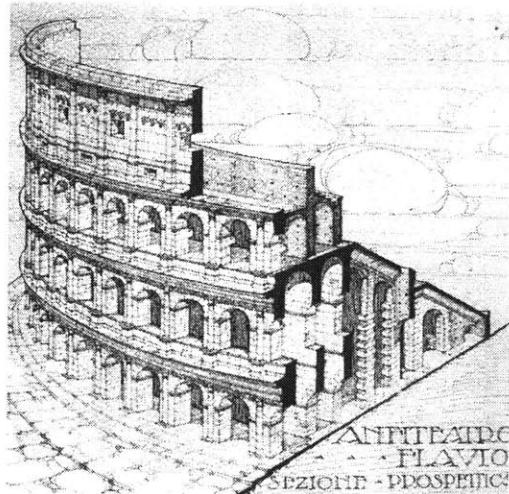

Figure IX: Colosseum elevated section view

From a structural point of view, the Colosseum was constructed following a three dimensional approach with a series of arches and vaults that radiate and enclose the elliptical structure. The weight is carried by the vaults and distributed to the travertine piers and concrete walls. As mentioned before, the engineers utilized a combination of different material types available such as concrete for the foundations, travertine for the piers and arcades, tufa infill between piers for the walls of the lower two levels, and brick-faced concrete for the upper levels and most of the vaults. This approach of using the appropriate materials for each section proves an understanding of the behavior of each type as well as the search for cost effectiveness and rapidity of erection.

Other than a system for the canopy, the Romans did not invent any structural system for the Colosseum but rather used what they were experiencing in the construction of their buildings, bridges and aqueducts. The arches and vaults were well integrated in the Roman architecture even before the first century as well as the use of concrete. Concrete was proved, from ancient writings, to have been already in use since 199 B.C in the

works at the harbor of Puteoli. The use of these engineering elements was well embedded in the construction of the most famous stadium of the ancient era. It is interesting for that matter to focus on each of them in an attempt to understand what they brought to the best of the structure. (Chap 3& 4)

The structure has seven concentric groups of travertine piers that circling the whole stadium. The pillards decrease in dimension going from the exterior to the interior as they become less loaded. The piers running at the perimeters of the ambulatories are connected to each other by a series of stone arches that transfer the upper loads through and outward thrust into the pillars. These thrusts tend to spread the arch and overturn the pillars. However, the outward thrust of each arch is counterbalanced by the same thrust coming from the adjacent arches at each side. Because the structure was designed as enclosed, the groups of piers run on a whole ellipse allowing all the arches to be adjacent to each other. No support was needed to counterbalance the outward thrust of the arches until later in the life of the amphitheatre when parts of the structure fell under numerous reasons such as earthquakes and looting. The arches at the extremities were then supported by the means of buttresses.

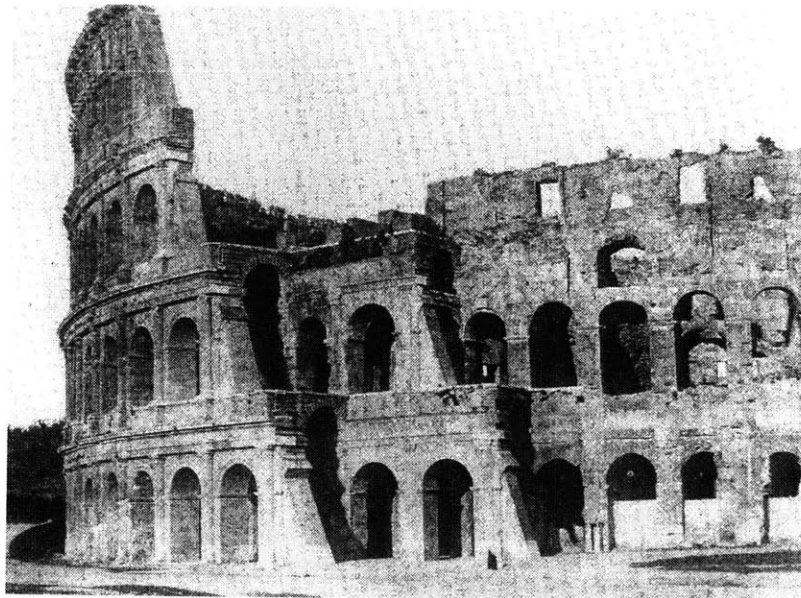

Figure X: Support buttresses for arches

The concentric walls pierced with arches are connected to each other, at each level, by a series of concrete brick faced or unfaced vaults. The vaults are used to spread effectively the load coming from the seating area onto the boundary walls supporting it. The vaults are rigid enough to provide the walls at each story level with an effective bracing. In that case, the inter-story wall reacts as an individual element. It is also obvious that the whole web of walls and vaults provides the Colosseum with structural rigid frames (Figure IX and XXXII). The joints in the rigid frame are pinned as the mechanical connection between the concrete and travertine blocks allows the rotation. However, in order to increase the bonding and shear resistance at the interface, the surface of the stone used to be roughened before the pouring of the concrete (Figure XXXII) ([d], p153).

2.4 Canopy overview:

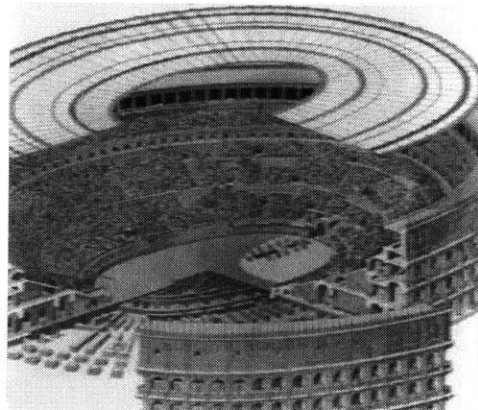

Figure XI: Colosseum canopy

It might seem impossible to some people that the whole Colosseum was covered, but the Romans integrated all their ingenuity in the construction of this monument. They used the things they learned from their experiences in other fields and implemented them wherever it was needed, such as the handling of the masts and sails in ships. Depending on the weather, an enormous colored awning⁷ (velarium) 600 feet in diameter, could be stretched to prevent from the sun on wind free days.

It was a retractable cover and the cloths that formed it were held with cables by the means of rings sewn to it. Evidence from archeological surveys, the existence of corbels and sockets at the top of the Colosseum, the matching holes in the cornice and finally the preserved roman coins that showed masts all around the top, give undeniable proof of the existence of the canopy. The corbel supported 240 wooden beams that projected upward through corresponding holes in the sockets held the awning. It was maneuvered by a unit of sailors of the imperial fleet, stationed nearby, as it was big and needed experienced people to deal with.

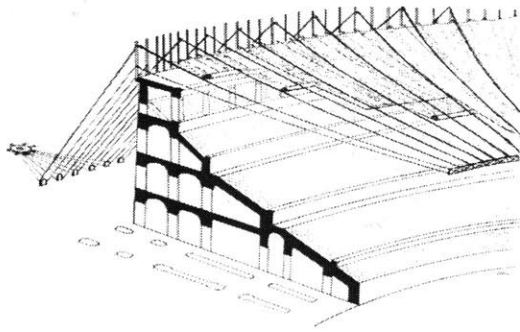

Figure XII: Canopy cables and pulleys



Figure XIII: Roman currency

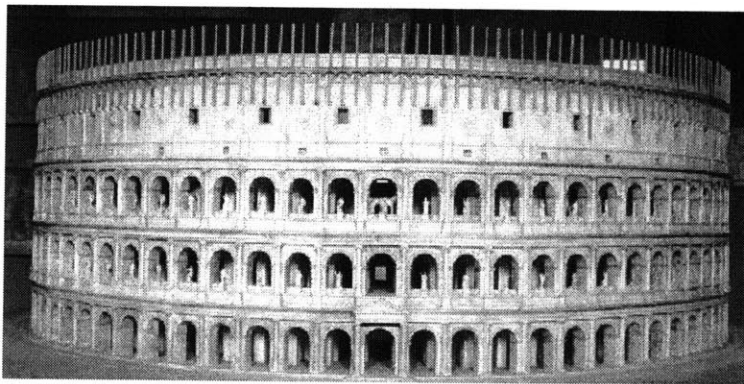

Figure XIV: Colosseum model with the cover masts

The use of the corbels, sockets and a pulley system was a very ingenious approach for this complicated problem. To maintain tension on the lines, it has been suggested that they were tied to a corresponding number of bollards around the outside perimeter of the Colosseum. The lines attached the awning to the wooden masts at the top of the fourth level and then went to the boundary stones delimiting the surrounding area of the Colosseum, before being attached to the bollards. Three of the five stone pillars remaining can be seen in Figure XV.



Figure XV: Support bollards

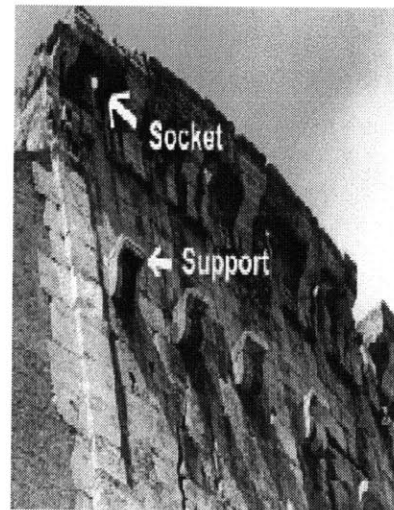

Figure XVI: Mast supports and sockets

The existence of the roof is undeniable and the evidence given before proves it, but little is really known about how it worked, what shape it had and how it was retractable. What was described previously is the currently most accepted explanation. This subject is however still being looked at, and many intellectuals have presented other solutions. Some even believe that the blocks shown in the picture above were not used for the canopy, but rather were a mean to control the crowd [9].

3.1 Introduction:

The most important thing that made the Colosseum last so long is the extensive use of arches and concrete. It is one of the most important Roman monuments where innovative use of arches, vaults, stone, brick concrete and many others was implemented. Although the invention of concrete was not for its particular use in the Colosseum, it was very useful in the construction of the barrel vaults used in the amphitheatre as structural elements. The use of concrete was also important for the foundation and the walls. It is interesting for that matter to focus separately on each of the Roman concrete, arches and vaults, in an attempt to explain their effect on the structural behavior of the Amphitheatre. “The structure (Colosseum) has been damaged several times by earthquakes and fire, but those portions built with Roman concrete endure”. Stephani Miller, Ref [i]

3.2 Types and properties:

Concrete is one of the most important inventions that the Romans incorporated in their structures. The primary form of concrete/mortar made out of lime, was used as early as 2,500B.C as a bonding agent by many early civilizations. However, it was not regarded as an important structural material until the Romans found a better use for it and improved its properties allowing them to push innovations in the design and construction of their structures.

The new material was easier to handle, faster to erect and as hard as stone. As quoted by De Camp and transmitted by Norbert Delatte “here for the first time was a completely satisfactory waterproof concrete, which formed a synthetic rock as hard as most natural rocks. In fact, samples of Roman concrete that have come down to modern times in buildings, conduits, and the like are harder than many natural rocks would be after so many centuries of exposure” [j], [h]

The mortar that the Romans used before inventing the *opus caementicium*, which we call Roman concrete, was made of simple lime and river sand, mixed at a ratio of three parts sand to one part lime ([i] p 16; [e] p 47). It was used as a bonding agent for stones or as a plaster called stucco for external covering. The Lime is obtained by calcination, or burning of limestone. The resulting product, an oxide of calcium, also called quicklime, is a solid material that can be hydrated to give a bonding agent and essentially form an artificial limestone when it hardens.

In his book *The Ten Books on Architecture*, Vitruvius^a, a Roman engineer, notes that for each type of mortar, the stone to be burnt is different. He specifies the use of close-grained hard stone for the mortar, because strength is important and porous stone for the stucco, because lack of shrinkage and cracking is important [j]. While extensively using mortar and through the trials of different types of sands, the Romans discovered the virtues of a certain type capable of giving a mortar far stronger than what they were obtaining with usual sand.

The mysterious “sand” is nothing else but Pozzolan. The Romans had abundant amounts of Pozzolan, *pozzuolania* in latin, also know as volcanic ash. Its name comes from the Pozzouli region by the Bay of Naples, where it was found. Vitruvius describes this material in his book by saying” there is a kind of dust, which by nature causes marvelous results. It is found in the vicinity of Baiae and in the property of municipalities around Vesuvius. When this material is mixed with lime and rubble, it strengthens buildings generally, and when piers are constructed in the sea, they set hard under water” [e].

The concrete Romans invented was hydraulic, could set under water, as the archeological expeditions have shown along the shores of Campania, Tuscany and Latium, and had a relatively high strength. Tests conducted in a lab on a 76 mm Roman concrete cube specimen taken from Roman ruins in Libya gave a strength of 19.3 MPa ([f] p56). This high performing concrete was made possible through three critical elements: rigid quality control through the careful material selection, good proportioning of the materials with the use of low water to cementitious materials ratio, and the use of expert workforce for the placement and compaction in the critical elements and whenever it was needed. The composition was made out of two parts of pozzolan and one part of lime with a 15-20% of water ratio. ([i], [e],[j] table1)

The Romans mixed different aggregates with the pozzolan cement they invented, such as broken tuff⁶, travertine, brick, marble, or even pumice stone which was used for the vaults to lighten the weight of the structure [k]. Apart from being easy to handle and shape, lighter than stone, and cheaper because it did not require special skilled labor force for the mass work, concrete was known to be a fire proof material, thus safer than wood. Concrete replaced the timber construction during the Roman Empire especially in the amphitheaters. After the fall of the Empire and until the beginning of the eighteenth century the relatively small amphitheaters and theaters that existed were constructed with wood, thus none of them survived long.

Because it needed form work to be placed, the surface of the unfaced concrete was usually rough and judged ugly after removal of the wood centering. The Romans resolved this aesthetical problem by covering the concrete with other materials such as stone. It also gave a feeling of comfort and security to the people who had reprehension towards the new material. This procedure was particularly done for the concrete walls and arches; however, the reasons given above were not the only ones for it (Section 3.3). For other elements, the concrete was generally painted.

3.3 Concrete Walls:

During the Roman era, walls were built out of stone, ordinary masonry or concrete (faced or unfaced). Unfaced concrete was used for the underground walls; as for the visible they were always faced. Before the Roman concrete was invented, the construction with large stone blocks was common in the Empire. It was however very demanding and presented a number of difficulties. The stones needed to be well-cut, great effort to be placed and the construction took a very long time to be completed [k]. The call for stone structures started to decrease with the engineers shifting to masonry, as it was faster to erect and easier to handle.

In the mean time the concrete was in the testing phase and it was only used for the foundations. When the use of concrete started to evolve, it was integrated as the main core in the construction of other structural elements mainly walls, with the use of different materials for the facing such as stone or brick. It is not quite understood why the walls were always faced, but many explanations refer to the fact that it allowed the construction without the use of wooden formwork, it retained the moisture during the curing of the concrete, it gave great strength with less expensive stone usage, it was more aesthetical and it gave a fake illusion to the people who were discomfoted with the use of concrete. Different materials were used for the facing such as stone blocks or bricks and in different forms, mainly triangular or pyramidal shaped or unshaped. The walls were classified in three categories depending on the visual appearance and the use of materials, however this classification was also indirectly related to their strength, which is

not only function of the thickness but also the type of materials used and the way they are laid. [j]

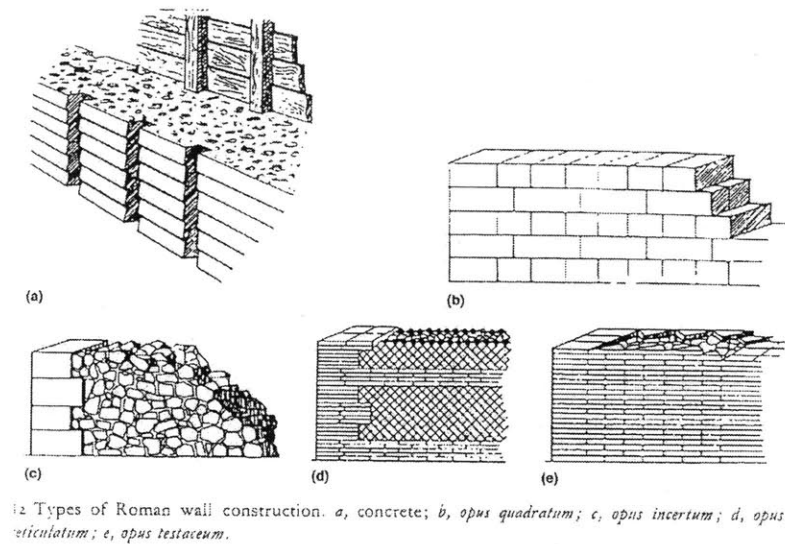
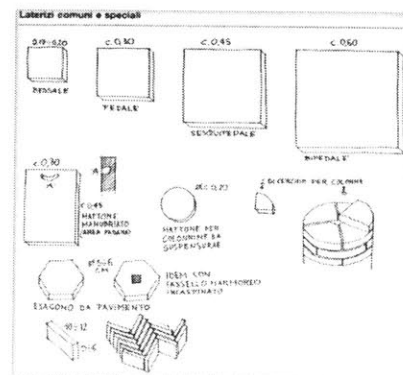

Figure XVII: Roman wall types

- 1) opus incertum: a type which uses stone block, mainly tufa blocks of random sizes and shapes set into the concrete wall in such a way as to give an irregular design. (Figure XVII (c))
- 2) opus reticulatum: a type which uses standardized tufa blocks set into the concrete core in regular way, but results in a less stronger wall than the first one. (Figure XVII (d))
- 3) opus testaceum: a type which uses bricks for the facing. It was by far the most common during the Empire. There are three main sizes of bricks: Bessales(8 inch sq), Sesquipedales(1 and half feet sq), Bipediales(two feet sq). (Figure XVII (e))

Figure XVIII: Roman bricks



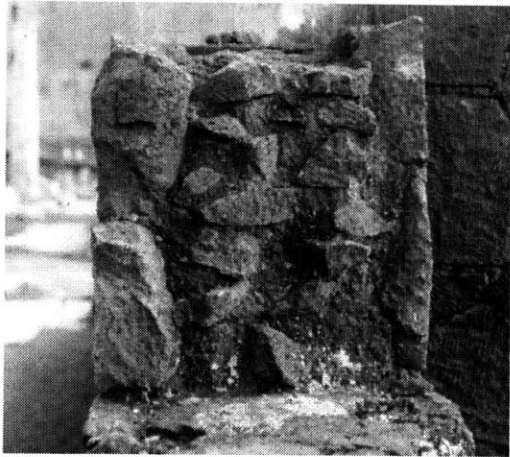

Figure XIX: Opus reticulatum

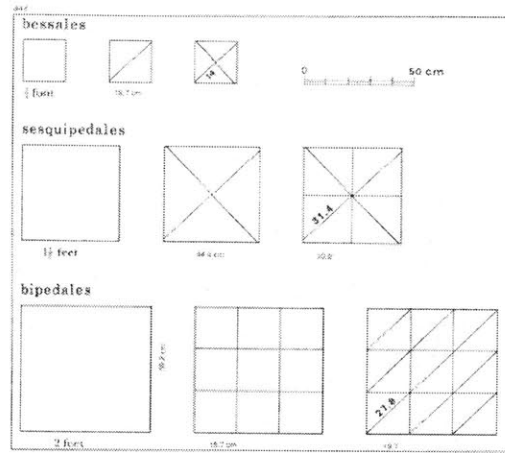

Figure XX: Roman bricks



Figure XXI: Opus testaceum

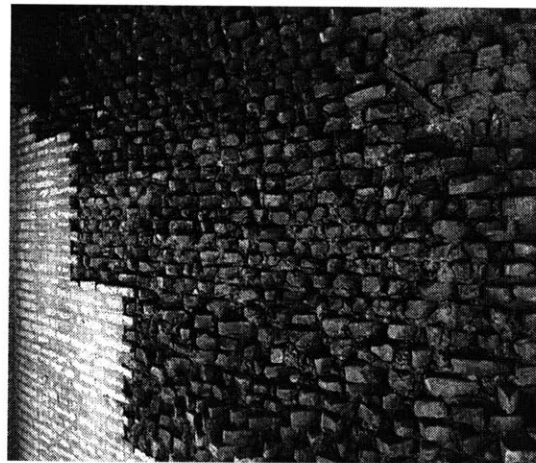

Figure XXII: Opus testaceum



Figure XXIII: Opus incertum

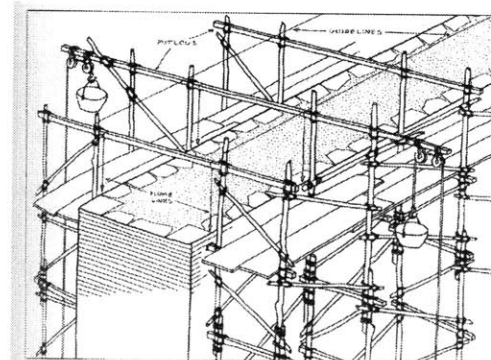

Figure XXIV: Roman scaffolding

During the period of construction of the Colosseum there was an emergence of the brick faced concrete wall, which was used in some parts of the stadium. However, intentionally, the exterior wall was constructed in a conservative way using the method of large blocks of travertine called Opus quadratum. This kind of walling was usually used in the case of large public buildings and specifically in the Colosseum because of the unprecedented size of the structure and the enormous loads the wall had to bear. The Romans were aware of the limitations of their composite wall and preferred not to take risks when it's not needed, especially in the case of public buildings ([k], [d] p136).

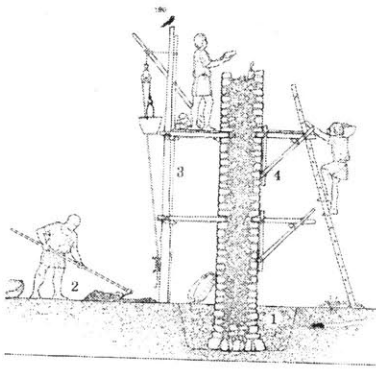

Figure XXV: Wall construction

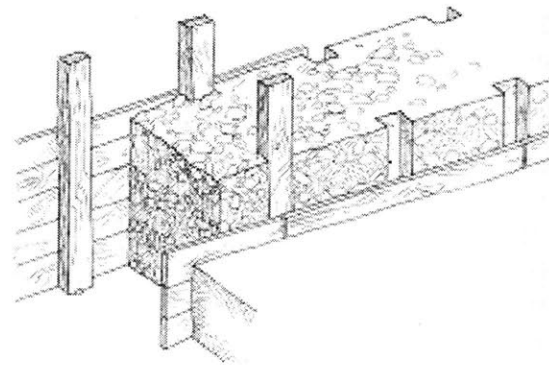

Figure XXVI: Foundation wall formwork

3.4 Construction process:

The construction process was similar to the one used in our modern days. In the case of the underground wall, which was erected to hold the soil during excavation, the workers used to first place wooden formwork and then pour concrete with aggregates in a semi-fluid state. The wall would then be considered as part of the foundation. The clapboards were for that matter placed on the inside of the formwork (Figure XXVI). They were meant to form a key in the concrete face, which will eventually increase the resistance to settlement by increasing the friction at the interface earth-concrete ([d] p77). To be able to reach the top of the superstructure walls as they gained elevation, scaffolding was used during the construction (Figure XXV). The wall facing materials were used as formwork on each side instead of wood. They were laid in concourses on both sides and the space between them was filled with rubble and layers of compacted concrete.

4.1 Introduction:

Contrary to what some people believe, the arch was not a Roman invention. However they “applied it with great skill and success to various works of utility, and made it a universal feature in civil buildings” [6]. Very primitive forms of small stone arches and vaults for the burial chambers were constructed in the Middle East as early as 5000_{BC}.

The earliest example of an arch as an architectural element is believed to be the semi circular brick arch built about 1400_{BC} at Ur in Mesopotamia [c]. The use of arches was implemented on a small scale in the Greek and Egyptian culture, as they preferred the posts and flat lintels, but was commonly used by the Etruscans of Northern Italy as they understood its many advantages and from whom the Romans took this practice.

They adopted the semicircular arch to span over openings in the walls; they also used it as a relieving arch during the construction as a base element for the vaults. The Romans

were funded by the construction of large buildings that would commemorate their gods and the power of Rome. To also meet the requirements of the growing population of the Empire, the sizes of the buildings had to grow too. The use of columns and lintels became a problem as the bigger the building is; the more it needs posts to hold it. Thus the Romans turned to the extensive use of the arch, which behavior they understood after several trials and errors.

By using arches instead of columns and beams, the weight is carried by compression forces in the arch rather than bending in the beam. It increased the amount of load that can be taken as well as the span that can be stretched, thus giving more clear space in the vicinity. This can be compared with the Greek temples, where the use of posts and lintels induced a great number of columns needed for the support of the structure. Also visible in the Greek temples are the cracks along the mid-span of the lintel where the maximum stress is created.

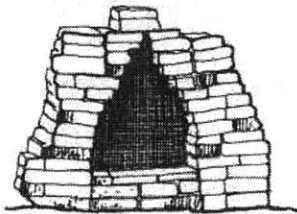

Figure XXVII: Primitive arches

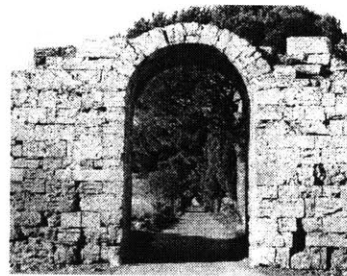
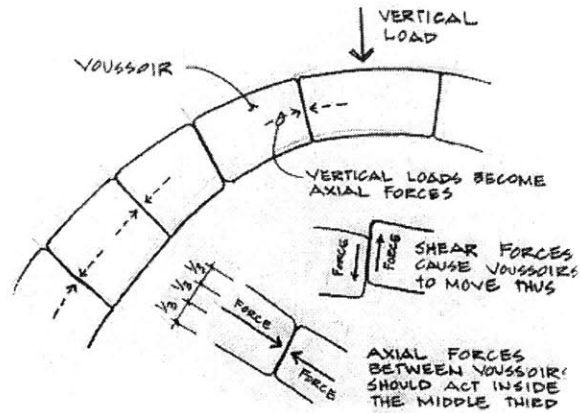

Figure XXVIII: Voussoir arch

The Romans solved this problem by using a type of arch construction called voussoir arch with keystone. They used mathematics in all the aspects of their life and more particularly in their use of the arch. The most common form of the arch they considered was the semi-circular one. However they tried other forms, such as the segmental arch (part of circle but less than a semicircle) or flat arch. All types were used in the Colosseum but the segmental and flat arches on less frequent bases, as the Roman engineers understood their constraints in comparison with the semi-circular one. They also had a form called the triumphal arch, which consisted of three arches with support beams that separated them.

Figure XXIX: Forces in a voussoir arch



4.2 Voussoir arches:

The Romans took the cut stone technique from the Greeks who were using it to erect flat arches, and experienced it on semicircular arches. In the trials of the arch as a new structural element, they understood the need to provide a fix support in order for the force generated in the arch to be transmitted to the piers and then to the foundations. The form of the arch was secured by the use of the Keystone block at the top and of very heavy travertine blocks for the bases.

The shape of the arch allowed the force to be transferred as compression between the voussoir blocks and onto the other structural elements. Because there is no mechanical connection between the voussoirs it is crucial not to have tensile, or significant shear forces between the blocks. This is the case in a funicular arch. It is believed that the Romans did understand the structural behavior of arches not through some kind of scientific formulation but through sharp contemplation and intuition. The first design of semi-circular and part of a circle shapes were generated using simple geometrical forms they inherited from the Greek mathematicians.

Through many trials they discovered that the part-of-circle arch is less effective than a semi-circular arch as it is more close to a simple beam and is likely to have more bending and shear thus more stress on and between the voussoirs blocks. Mostly, they relied on the semi-circular arch, which shape is more elevated than the other types but is proved to be more stable. In the semi-circular arch, the line of thrust does not coincide with the shape of the arch, as it is parabolic, and the internal forces are not perpendicular to the cut of the voussoirs. However, as long as the compression force remains in the middle third

and no shear force, not able to be taken by the friction forces of the voussoirs, is generated, the arch is safe.

Roman builders knew that through common sense, and it was their ability to use the appropriate dimensions for the arch and materials that made it stand. The weight and the quality of each stone block had to be well chosen and the cut roughened, to be able to generate friction force, so that the voussoirs and particularly the Keystone wouldn't slide inward or be projected outward under the relative forces. They also cut the voussoir blocks in a slightly trapezoidal shape in order to increase the resistance to sliding. Sometimes Romans also bonded the blocks together with layers of mortar and in the case of dry-jointed masonry, with metal clamps made out of iron or bronze ([f] p72). During the construction, a temporary centering supported the blocks until the keystone is inserted.

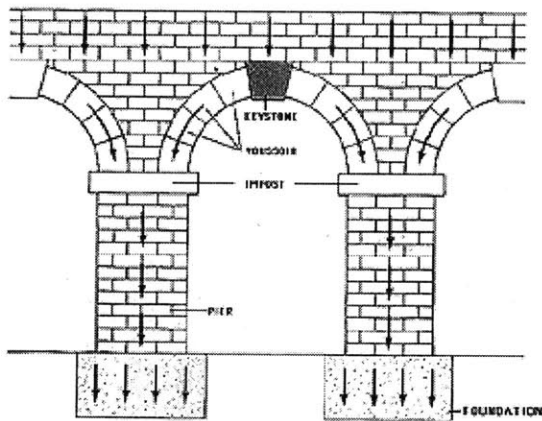

Figure XXX:
Distribution of forces from a voussoir arch

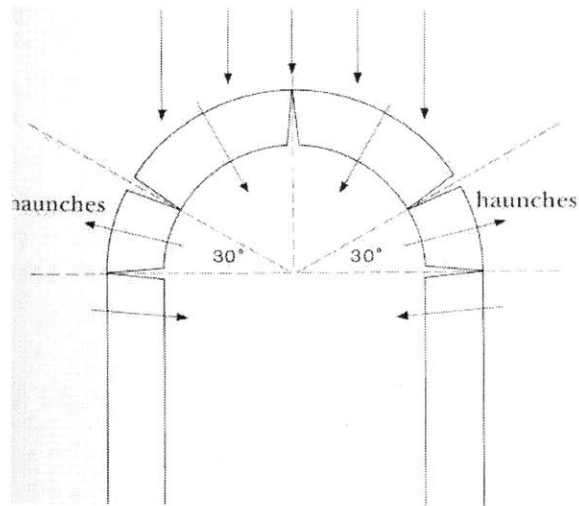

Figure XXXI:
Destabilizing forces in a voussoir arch

Because the arch generates an outward force that tends to make it split, abutments are needed for the support. Romans resolved this problem by building a series of arches, which counterbalance each other's outward reaction. This can be seen in their bridges and aqueducts. They became very experienced with arches and extrapolated their use to many different structures, mainly amphitheaters. Even though concrete arches and vaults were widely used in the Colosseum (Section 4.3) voussoir arches form a major element of its

structure, particularly the exterior wall. The continuity of the Colosseum walls allow for all of the arches to counterbalance the outward force of the adjacent ones. Because of the amphitheaters curvature the arches also generate radial outward force that is fortunately small and could be counterbalanced by the weight of the materials.

4.3 Concrete arches and vaults:

The invention of the Keystone arch was a major breakthrough in Roman construction, but it came with many difficulties and disadvantages. The blocks needed to be of a very good quality, the weight was very heavy, the cutting and placement needed experienced work force and it took long time to be constructed. With the discovery of concrete, the Romans began to use it for arches, as it was lighter, easier to handle, faster to erect and can be molded in different shapes. This discovery helped the spread of the arch construction even more.

Because the Pozzolan based concrete took a long time to come to full strength, wedge-shaped stones or tiles voussoir arches were used as relieving arches until the concrete cures. After experiencing the numerous advantages of arches, Romans explored vaults as structural elements. They realized that to some extent it is an extrapolation of the arch as it is simulated by a number of arches that lie side by side. They also knew that similarly to arches, the external load and the weight of the materials exert in the vault a downward force as well as a side thrust that tends to make it spread.

The thrust has to be counter balanced by either thickening the wall at the haunches or placing buttresses to support it. This disadvantage as well as the weight of the material has controlled the evolution of masonry but revolutionized the use of concrete, which was the primary material for the vaulting of the ambulatories in the Colosseum. It is proved under normal conditions that concrete vaults and masonry vaults, where bondings between the elements exist, act similarly. However, this did not stop the transition from the masonry vaulting to the concrete vaulting when the second material was invented.

The transition took place because of the advantages that concrete brought as a more efficient bonding component and as a material which weight can be adjusted. It gives the possibility to use heavy stone as aggregates at the base of the concrete vaulting and lightweight stone such as pumice at the top, enabling engineers to cover vast spaces without interior supports and with less weight ([d] p 176).

Romans invented different complex types of vaulting by combining the simple vault in many shapes in order to get the barrel vault, the cross or groined vault, and the dome.

At the lower level of the Colosseum, three continuous vaults encircle the amphitheatre forming three ambulatories used as the main passageways. Other vaults exist on the upper levels. Groined vaults were also used, consisting of two-barrel vaults intersecting at right angles, allowing a span over large rectangular areas with only support at the edges. The ambulatories vaults were cast in concrete between two thick stone walls and supported by a corbel like sticking line of stone that helps transfer the loads.

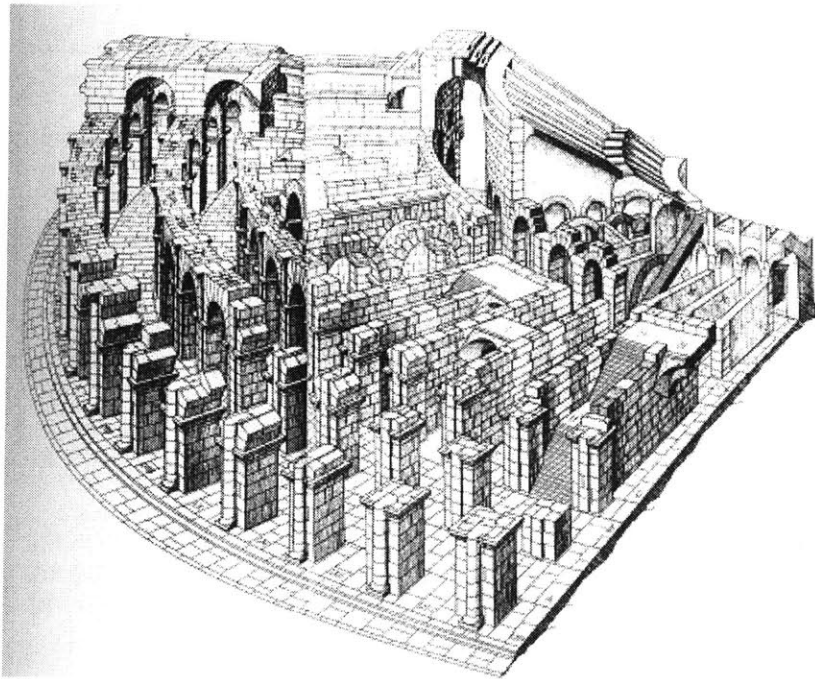

Figure XXXII: Colosseum axiometric view

In a beautiful demonstration of their feel for architecture and efficient use of space while working with a structural system, the architect-engineers used the interior walls in the Colosseum as an integrated system of buttresses meant to counterbalance the outward force of the vaults. At the extremities, the thick walls that run on the longest and shortest perimeters of the stadium take the outer forces. Due to the use of a semi-circular form in the vaults, the ambulatories are relatively elevated. Brick arches were often integrated in the mass during the corridors construction in order to relieve the weight of concrete until it hardens and reduce its shrinkage while being integrated as construction joints.

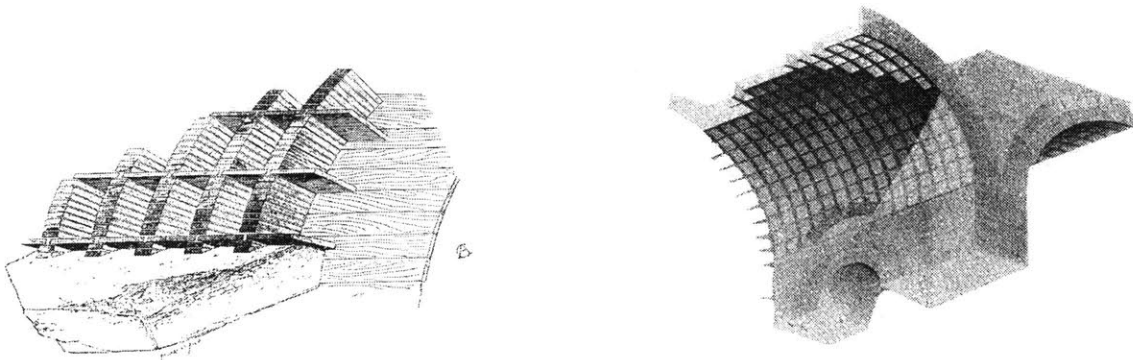

Figure XXXIII: Relieving brick arches in the concrete vaults

Figure XXXIV:
Concrete vaults in the Colosseum ambulatories



5.1 Introduction:

“Safety requirements, ensuring his client’s safety and protecting his property, are the primary responsibility of the structural engineer in any time or place. To fulfill this heavy responsibility, the engineer must fully understand the nature of his site, the uses of the structure, and the behavior of the materials of construction. Wherever recurrent loads are expected, he must know the ability of floorings, transport surfaces and underwater structures to withstand normal and, on occasion, extraordinary pressure. The structural behavior of a material must be thoroughly understood: a well-designed structure must be expected to carry a variety of loads without sustaining extensive damage or causing loss of life. Today the engineer is professionally and legally responsible for the satisfactory performance of his structure. Intuition and judgment based on experience are basic to the professional exercise; the decision of the experienced engineer has always been the most important factor in the design” Vitruvius ([e], p36).

The Romans took good care of their important buildings and made them last long enough to live for centuries. Safety was one of their main concerns even though it was not always implemented, because of the lack of regulations. During Vitruvius' life, in the first century A.D, the useful life of a building was set to 80 years. However he points out that with some care it would last longer [j]. The contribution of the different elements in the Roman workforce made the design and construction of several monuments that follow the 80 years criterion possible and even go beyond it to follow a 2000 years criterion.

It is obvious that the architect-engineer was the most important figure in the workforce of any construction project. During the first century A.D the engineer became “professionally and legally responsible for the satisfactory performance of his structure”. It implies that, during that time, the architecture-engineering profession began to be reformed in an order with rules and obligations to follow. The *architectus* was considered a very important figure and held very high esteem in the Empire ([d], p 9). The profession became so popular that the Emperor Tiberius' son practiced it.

The requirements needed from the engineers in order to fulfill any design job were the same as those existing in our current days; a complete understanding of the site, of the uses of the structure and of the behavior of the construction materials. In order to accomplish these requirements Vitruvius sets rules for the engineer to follow citing that he should “be a man of letters, an expert draftsman, a mathematician, familiar with scientific thought, a painstaking student of philosophy, acquainted with music, not ignorant of medicine, knowledgeable about the opinions of jurists, and familiar with astronomy and the theory of the heavens” ([e], p 12).

However hard this might seem to be achieved; what Vitruvius wrote, only shows the importance of the work required from an engineer and the level of experience and capabilities he should be having. He explains some of his requirements by emphasizing on what each one brings to the profession”...mathematics teaches the use of ruler and compass. By optics, in the case of buildings, light may be derived from certain quarters of the sky. By arithmetic one may assess the cost of a building...” ([e], p12)

It is not known how the title of architectus was given out and who was considered to be a member of this important order, but Vitruvius complains that an art of such magnificence is professed by persons without training and experience, by those who are ignorant not only of architecture but even of construction...” ([h], p165). This problem arose when “many were prompted to enter the architectural profession asking for fame and fortune, after the boom in the construction during the first century of the Roman Empire”([e], p13). He also complains about the Property-owners who are not following the rules of the ancestors anymore by not choosing the architects with a decent background and not inquiring if they had a liberal education.

It is important to acknowledge that the architect of the Colosseum, whose name remains unknown, does not fall in this category of ignorant engineers but is recognized as a genius and complying to all of the requirements set by Vitruvius. It is clear that he knows among others, mathematics, due to the pseudo-elliptical shape of the Colosseum inducing the use of the compass, behavior of structures due to the immense web of arches vaults and enclosed ambulatories, and construction, due to the time record for the erection of the stadium.

Apart from the architect-engineer, the workforce consisted of experienced workers in all the other professions related to construction, such as the agrimensores or surveyors, libratores or levelers, masons, and others, as well as non-experienced workers used for the mass tasks. The grouping of all these elements in the Roman workforce was behind the delivery of magnificent structures in the most efficient way possible. They conducted the construction using different kinds of materials and machinery they invented or knew about from other cultures, such as the pulleys and winches.

With their machines and construction techniques, they were able to put in place, with high precision, huge columns of stone weighing tones of kilos.

By just looking at their Colosseum or Temple of Jupiter it is evident to realize the high sophistication level of construction procedures they established.

5.2 Building regulations and contracts:

It is now known, from the translations of the writings of Vitruvius, that the Romans had building regulations. These regulations set rules for the architect to follow in the design and estimation of the cost. In his book, Vitruvius particularly refers to the legal code of Ephesus, which, in its cost estimation part, defines the responsibility of the architect to pay the exceeding amount over the twenty five percent difference in the total cost estimation. However these regulations were only related to public building projects ([e], p 14).

In the case of private buildings, laws and regulations related to building practice and safety measures were lacking in Rome. Vitruvius mentions this with regret when he talks about the Ephesian code:” If only the everlasting Gods had made this a law of the Roman people, also, not only for public, but also for private buildings...” ([e], p14)

This is because, a great number of houses collapsed due to the construction of insecure buildings and the lack of responsibility from the part of the contractor.

The laws that are clearly documented and relate to contractors are those talking about the provision of workmen and slaves. These laws, in the form of a contract were made with freedmen and private individuals and were controlled by the state. Unlike the Greek writings, the Roman documents lack of specific notes on contracts dealing with procurement of materials and construction. It is not known if the “contractors” mentioned earlier are the ones that also deal with the whole process and issues of construction, or they just take care of the human resources.

Some other documents, related only to public buildings, talk about *locatio conductio* ([d], p16) a form of contracts that is similar to the modern ones. The contract is made between the actual builder of the structure and the employer and consists, among other matters, of setting a deadline for the conclusion of the work as well the terms for the payment. Arbitration clauses were also included to be used in the case of dispute between the two

parties or failure of the contractor to complete the project; in the final case the second half of the builder's fee is not paid.

The bidding process was the followed procedure in many public contracts. "When they give public notice of intent to let contracts for the building of temples or colossal statues, listen to the proposals of the artists competing for the commission and bringing in their estimates and models, and then choose the man who will do the same work with the least expense and better than the others and more quickly" ([d] p17).

Similar to our current days the time and cost estimate were the most important aspects of the bidding contract. They were always given with proof of calculation. It is obvious from what was said, that the delivery method used by the Romans was the Design-Bid-Build process. However this may not have always been the case since some believe that the fourth story of the Colosseum was not part of the original design but was introduced later and since sometimes the architect was himself the contractor, dealing with the design and construction. Design-Build process was in that case used.

5.3 The workforce:

As said the architect-engineer was the most important figure in the workforce. He conducted the study of the design and the choice of the material. In a second place comes the contractor, who had the responsibility of coordinating the work between the different entities according to the design planes. Little is known about who assumed this position. From the ancient documents available it is believed that sometimes and for some projects the architect and the contractor were the same person.

However, Vitruvius, who sometimes assumed both positions himself, recognizes a separation between architect and contractor. Depending on the project sometimes the architect held the position of general contracting and assigned sections of the construction to several subcontractors who sometimes were also experienced architects. The principal job of the architect-engineer was to design but during the construction he held functions according to the wish of his employer.

In the case of the Colosseum, since it is believed that the construction was entrusted to four contractors working on the four quadrant of the structure, the most probable scenario would be where the architect-engineer was the designer and general contractor ([2], [m]). He then subcontracted each quadrant to a master builder. The subcontractors used sophisticated oral and written contracts to explicitly assign responsibilities for the different parties.

The different parties consisted of several kinds of labor force such as surveyors and levelers as skilled personnel as well as experienced carpenters, masons, stone and concrete workers used for the tasks that needed excellent finishing. For the other heavy works, the labor force consisted of slaves, freedmen, poor citizens and soldiers from the legions.

The master-craftsmen, or skilled workers, often joined and formed professional associations, or *collegia* in order to discuss the matters of the profession and provide a measure of life. Somewhat similar to the syndicates in our modern days ([e], p53)

5.4 Machinery and construction of the Colosseum

It is obvious that the Romans had efficient and reliable methods of construction and machines in order to be able to erect such enormous structures. Their stonemasons and bricklayers used tools more or less similar to the tools in our current days such as the brush, calipers, rake and trowel. As for the surveyors, they used the table or *chorobates*, plummet or *groma*, stakes and the setsquare. For long distances they used the *dipoter*, a water level, fixed on tripod stand, with vertical and horizontal movements and cross-line.

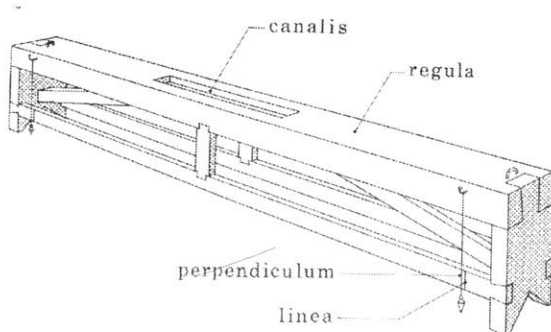

Figure XXXV:

Reconstruction drawing of the chorobates, based on the description of Vitruvius [n]

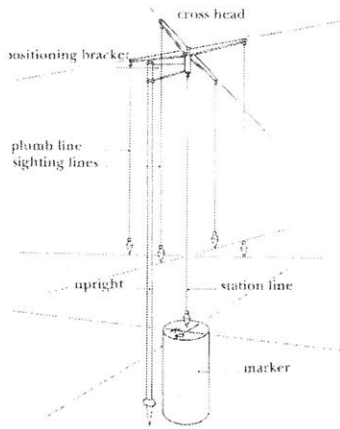

Figure XXXVI:

Reconstruction of the *groma* [n]

To lift heavy stones at elevated positions, the Romans used an ancient but very effective form of the current winches, made out of wood and manipulated by ropes and pulleys. For the construction of the Colosseum they utilized several of them working at the same time in different sections of the stadium in an attempt to reduce the time of erection. As it is known today, the construction of the Colosseum was finished in a relatively short time for a stadium of this size. The constraint on time was a big issue in the construction process and it is believed that the conventional method of construction, level over level, would have been too slow ([2], [m]). The small differences in some details of the construction pushed Cozzo to believe that the construction of the stadium was entrusted to four different contractors, working side by side in the four quadrants of the amphitheatre [2]. It is also believed that many of the component parts were built at different locations and then transported to their final destination in an early example of prefabrication. This allowed for a speeding up of the building process.

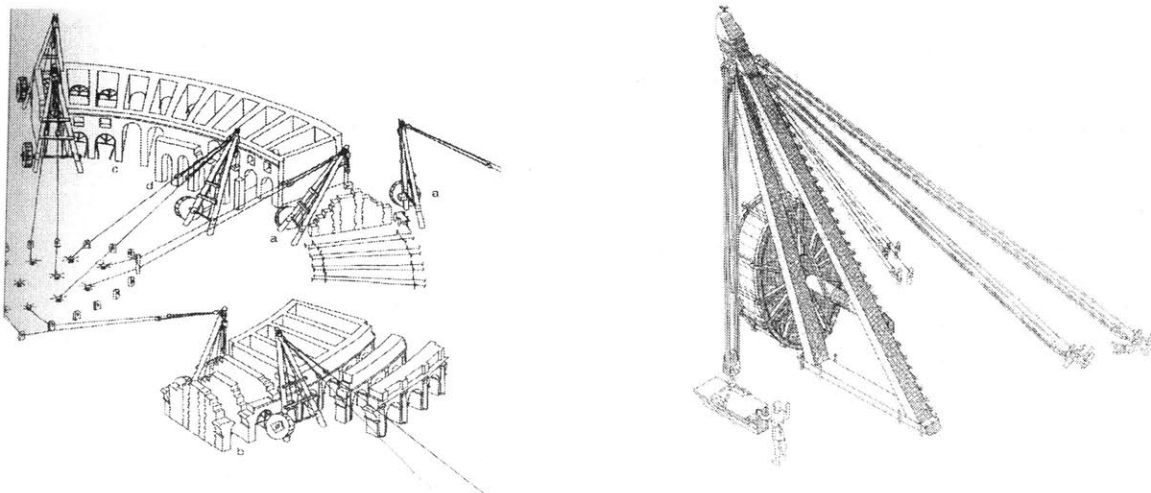

Figure XXXVII: Roman winches used for the construction of the Colosseum

The most probable succession of tasks that would allow the fast erection of the structure is suggested to be the following: “Once completed, the foundation base was covered by a travertine floor, 90 cm thick in average. On this stone floor the reference point for the main pillars were marked, and the base blocks of the pillars were anchored to the floor by a pivot and melted metal. This skeleton of pillars was raised up to the second floor, and the pillars were connected, at the top, by big arches made with 2 feet long bricks, placed in order to allow the construction of many rampant vaults, which together constitute the big cavea, destined to support the marble seats. In this way, the works could be carried on above and below the cavea at the same time, leaving only some vaults open for the lifting up of the materials. The space between the pillars was then filled by tufa *opus quadratum* on the ground floor, and by cement aggregate with a brick facing for the other floors”. Cozzo, translated by Andrea Pepe [2].

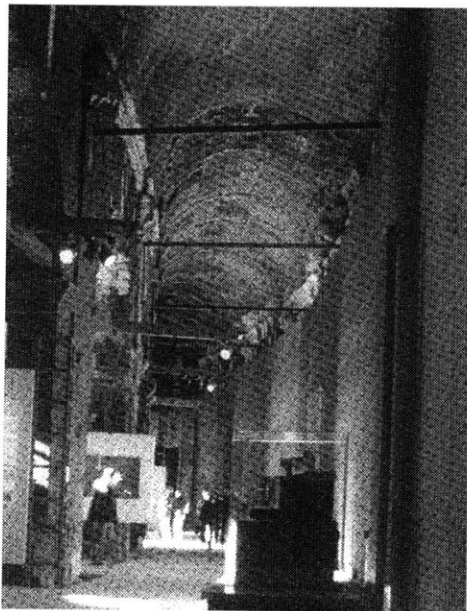

Figure XXXVIII:
Colosseum ambulatories

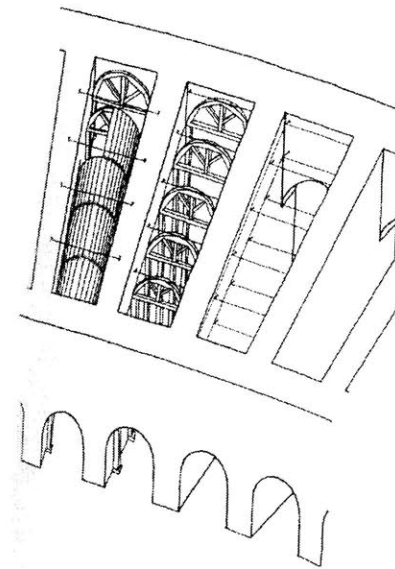

Figure XXXIX:
Vault centring

6.1 Introduction:

In the period between the fall of the Roman Empire and the industrial era the need for enormous and attractive entertainment places decreased as the emphasis of the society shifted to the construction of churches. The revival of the entertainment gatherings started at the beginning of the twentieth century with the rebirth of the Olympics in 1896 and the creation of many new games, mainly in England. The lack of places to host these events was met by the rehabilitation of ancient stadiums as a first step, such as was done in Athens. The technological advancements in the understanding of the behavior of structures as well as the invention of new construction materials helped, in a second step, boost the construction of new stadiums. These stadiums used materials such as steel, reinforced concrete, prestressed concrete or even composite, as they came along. The first “ modern “ stadium was built in England in 1908, using steel frame for the structure and wood for the bleachers. Combinations of different materials in the design and

construction were used to mimic the Colosseum whose different materials gave him the flexibility and resistance needed to be able to last forever. Stadium design and construction grew rapidly since the end of the nineteenth century to become the multi-million dollars industry it is today. Structural innovations such as huge thin concrete covers enclosing all of the stadium's space or movable seating structures made to accommodate the spectators depending on the type of game being played, were made for the specifications of each case bringing at each time efficient solutions to very challenging problems. Unlike the architectural approach used for any stadium, which considers following specific guidelines, the requirements of space, access and viewing, the whole structural approach is unique for each project; even though the use of materials and calculation methods is the same. It is for that matter difficult to set general guidelines for the structural design of any stadium; However the most followed approach for the seating area is the use of the structural frame similarly to what the Romans used in the Colosseum. A comparison between the Colosseum and the modern stadiums on the different design and construction aspects would be a good way to show the direct or indirect influence of ancient engineering on the current approaches. A complete and accurate study would be to look at all of these aspects. However, this will not be the case of the thesis, which will only look into the modern materials and the canopy in its tracking of the evolutions that occurred.

6.2 Modern concrete:

In the year 1824, Joseph Aspdin, an English stonemason, invented modern concrete. Even though other persons invented similar cement starting 1793, however it was his invention that was patented under the name of Portland cement, which is still the common name for modern concrete. 2000 years after the invention of Roman concrete, Aspdin took the ancient baking process one step further by heating together finely ground limestone and clay. The resulting substance, known as *clinker* was cooled and ground into a fine powder and was stored dry in bags for future use. The cement was hydraulic and gave strong and durable concrete, basically an artificial stone. At the beginning, the new material was not accepted very quickly and was mainly used as a bonding agent for bricks and masonry and sometimes as filler above the brick arches. However many manufacturers shifted to its production as it was very promising. The boom came only after the year 1850 when the concrete began to establish itself as an important construction material both in England and France where it was mostly utilized [f]. During that period and before the invention of reinforced concrete, the Portland cement concrete was used to form an artificial stone as it gave very good bonded and waterproof product. The fluid concrete was also used sometimes in the construction of Pisé houses. It was poured between the formwork to give monolithic walls and structure. In the 1830s pre-cast concrete blocks emerged in England and were used as building material as a first example of the prefabrication process.

During that time and before the invention of reinforced concrete, the engineers realized the primary weakness of the new material, which lies on the very low resistance to tensile strength, about the tenth of its compressive strength. However the material was still used in none bending elements as it was found to be very efficient in reducing erection time, giving the flexibility to be molded in any form and in fire protection. Since then many experiments were undertaken to improve the properties of the cement as well as its use as a more reliable structural element.

In 1849 Joseph Monier invented the first form of reinforced concrete, called ferroconcrete, when he used iron mesh in the fabrication of concrete pots and tubs. The use of the mesh helped him increase the tensile resistance of the material and control

cracks. He exhibited his invention at the Paris Exposition in 1867 with the help of Francois Coignet and encouraged the use of reinforced concrete in many structures. This invention was a major break through in the use of reinforced concrete as a structural element and was only to be rivaled in popularity by steel. Another rival came when Eugene Freyssinet, a French engineer developed in 1920 the prestressed concrete allowing more control of the tensile stresses and longer spans. Prestressing also helped the control of corrosion, which early concrete structures were suffering from. It directly relates to the control of tensile strength as well as the use of high quality concrete with low permeability, in order to resist to chloride intrusion. The invention of prestressing boosted the prefabrication of concrete elements and their use in multiple structures such as stadiums. The elements were pre-cast at a different location and different timing from the actual construction, helping by that reduce the time of erection, a critical issue in stadium construction due to the time constraints of the game's off-season. It also helped reduce the thickness of the concrete elements and eliminate the mass of congested framing underneath.

6.3 Modern Steel:

Iron, which is the predecessor of steel, was used in the ancient cultures as a material for the fabrication of many tools for everyday use. Iron is fabricated through the refining of iron ore to a point where it reaches 90 to 95 percent purity. Many ways were used for that matter and the archeological evidence dates the early temptation to as far as the 3rd millennium B.C. With time, modifications to the concentrations of the materials used during the fabrication opened the way to the invention of steel, which is today the second most mass-produced construction product after cement. Malleable iron, the predecessor of today's steel, was produced by firing in hearth and then was treated in the iron-mills. Henry Cort invented the rolling mill in 1783 and in 1784 he invented the puddling process. The main problem with Iron production was the high temperature needed to reach the melting point during the manufacturing process and which could not be attained before the eighteenth century. When furnaces became more efficient iron ore was smelt into liquid and then cast rather than wrought. During the seventeenth century, iron began

to be smelted with coal in the form of coke rather than charcoal as it generated higher temperatures and could take heavy loads of iron ore. The resultant product was very brittle and had little ductility. However the new process gave a major role to the cast iron, which has a carbon content of 1.8 to 4.5%, by making it the principal material in the construction of the first iron structures [f]. Steel, which contains 0.1 to 1.7% of carbon, was during that time a very costly and scarce material. It is the result of a refining process and its evolution was held back by the difficulty to obtain this relatively pure iron, until Bessemer found the way in the late 1850s. The properties of the steel, the invention of the refining process as well as the machines for the molding reduced its price and promoted its use as a primary structural material.

6.4 They look the same:

Looking at different modern stadiums we can see the close relation they have in some part of their construction or design with the Colosseum constructed 2000 years ago. In the case of their general shape, most of the current stadiums have elliptical or oval forms similar to the Colosseum. Some other stadiums have different shapes, depending on the games they host such as baseball. However, for most of the games, which usually have rectangular play ground, the elliptical shape is the best form for excellent viewing. Some architects forget this rule of thumb and tend to follow other forms or totally different design methods. This thinking is criticized by John and Sheard in *Stadia*: "Present-day designers could do worse than to spend time contemplating the achievements of the Colosseum before tackling their own complex briefs" [g].

A good comparison would be to look at both the Berlin stadium, which was built in 1913 and renovated in 1936 to host the Olympics, and the Colosseum. Even though the capacity of the Berlin stadium is larger than that of the Colosseum, they very much resemble in the elliptical shape and structural system, which is a concrete frame spanning over ambulatories for the access.

From the elliptical form to the use of different construction materials, to the erection process with the engineer and the contractors, to the use of prefabrication for the

speeding of the construction, to the use of the canopy and the use of winches and other materials, stadiums today and amphitheaters before, look the same.

Figure XL: Berlin Stadium, 1913

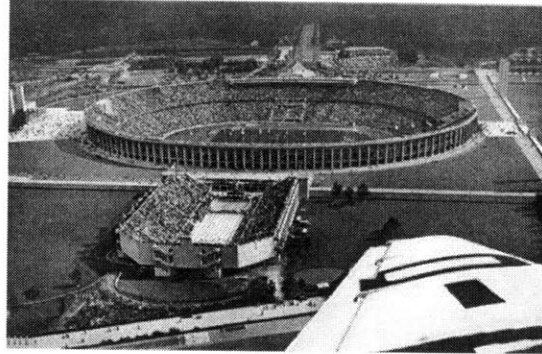

6.5 Canopy focus:

After citing the construction materials used in our century the focus in this part of the thesis will be on the innovations in the canopy. The other structural innovations differ from the ones used in the Colosseum by the use of the newly invented materials. To look into every detail of the advancements that these materials brought as well as the use of multiple structural design approaches is time consuming. The canopy is a unique element of the stadium's body. To only look just into it, is a good way to understand the evolution of stadiums on many different aspects mainly the use of modern steel and concrete. From the historical part that was written about the Colosseum and the introduction of the new and modern materials one can also track and figure the evolution on other aspects.

The Canopy of the colosseum was retractable, used only for the shade and could not be stretched in any weather. It was also held by ropes and pulleys and manipulated by sailors. In our current days, retractable roofs exist and they are massive structures that can be used in any type of weather. They are not manually manipulated anymore but rather by the mean of electronically controlled engines. Some other roofs are retracted using cables as a mimic of the Colosseum. However, this method was found in the case of the Montreal Olympic Stadium to be inefficient and was replaced by a fixed roof. Most of the current retractable roofs are moveable over steel girder and they open by sliding.

Not all of the roofs are retractable. Most of them are fixed, and, unlike the Colosseum do not cover the entire stadium.

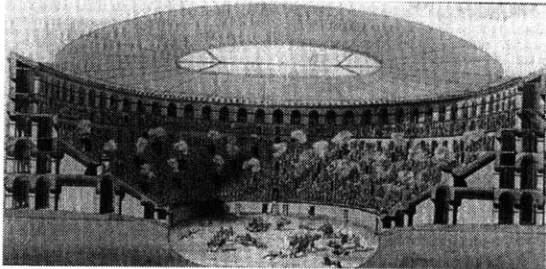

Figure XLI: Colosseum canopy

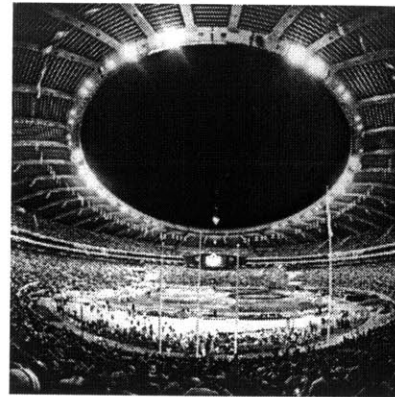

Figure XLII: Modern canopy

Most of these covers are made out of steel with the use of fabric for the top. When steel cables connected to fixed poles hold them, they are called cable-supported roofs. Some other daring designs were done by many engineers using concrete. Concrete covers were used for the Seattle Kingdome and by Pier Luigi Nervi for the Florence stadium. Other innovative roofs were constructed with the use of pre-cast prestressed lightweight roof panels supported on tension cables such as done in the Saddledome stadium. An example of ingenuity is the case of the Millennium dome in the UK, which covers the largest enclosed space until now. It is a membrane structure formed of lightweight material supported by twelve posts. Several types of covers will be discussed in the later section.

6.6 Overview of current roof structures:

6.6.1 Air –supported:

The idea behind air supported roof system design began in the 1970's when engineers tried to reduce the dead load in long spans. The reduction of the dead load was assumed by the use of fabric for the membrane cover with the air inflated from the inside counterbalancing the live load on the roof. The fabric members are connected through cables to steel compression rings that resist the uplifting force. Other than the pressurization that needs to be adjusted to resist the design loads, the structural efficiency depends on the symmetry of the system. The cables directions should be parallel to the diagonals of the enclosing rectangle.

For the construction, the fabrics are delivered as prefabricated synthetic sheets. They are usually made out of fiberglass or polyester with silicon rubber and Teflon used as a surface coating. The air-supported roof offers a very lightweight as well as cost effective structure. It is also very fast to erect as the fabric sheets are prefabricated, lightweight and easy to handle. Due to its low mass it is also seismically efficient.

The most famous example of the air-supported roof structures is the one constructed in 1975 for Silverdome, Michigan.

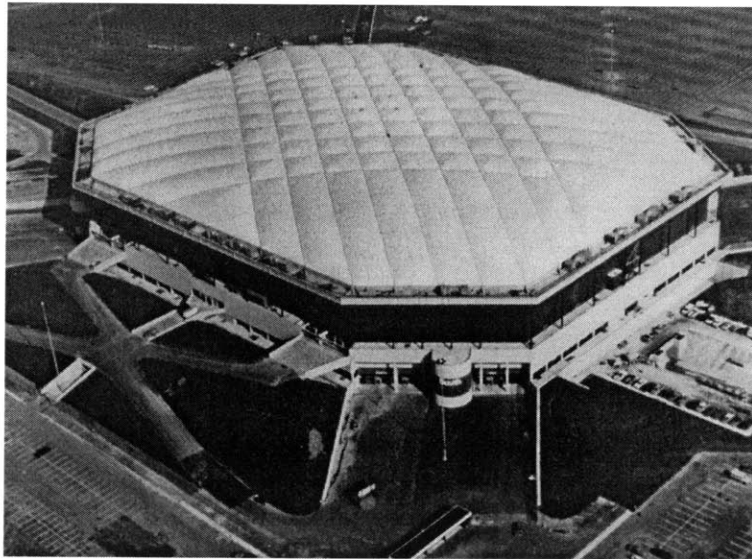

Figure XLIII: Membrane of the Silverdome

6.6.2 Cable supported structures:

Cable supported roofs evolved from the air supported roof structures starting the 1980's. They were invented to overcome the disadvantages of air-supported roofs while keeping their most important advantages such as the reduced weight and cost effectiveness. The system uses cables subjected to tensile stresses supporting the steel network that form the base, and masts subjected to compressive forces supporting the cables. They are architecturally very acclaimed as they present the possibility of various shapes such as the Saddle roof or Radial tent. However they also present numerous structural challenges for the engineers. From a weight point of view, they lie between the air-supported roof and the steel frames or trusses roofs. The cables are made of different kinds of materials such as Kevlar and a glass fiber, however, steel is the most commonly used, as it is cheaper. The roof is formed of prefabricated fabric sheets and the hole is assembled on the floor of the stadium then lifted up to position in a sensitive operation. An example of cable-supported roof structures is the cover of the Stade de France in Paris.

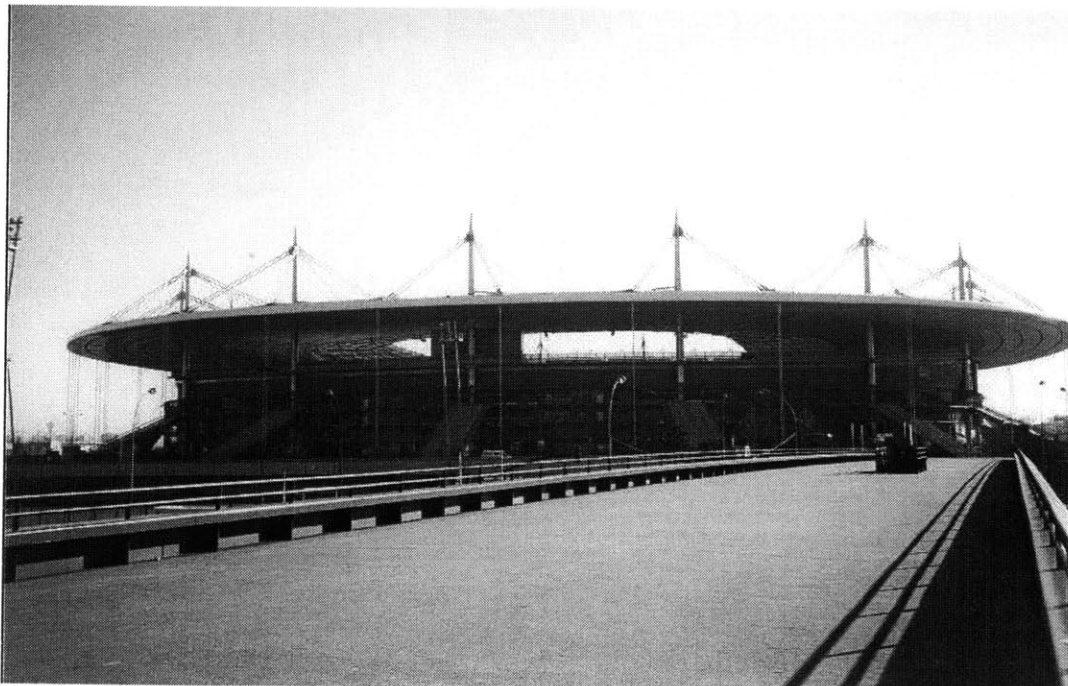

Figure XLIV: Stade de France cable roof

6.6.3 Retractable Roof structures:

The first stadium retractable roof ever constructed in history was the cover over the Colosseum. However it was only used for shading in sunny weather. Current retractable roof systems offer the availability of outdoor and indoor feelings for the fans and can be used in any weather. They also permit the natural growing of the grass under the sunlight. The first example of a modern retractable roof was the one constructed in 1961 for the Pittsburgh Public Auditorium Dome. However it is now permanently closed due to inefficiency in the mechanical sliding system. The retractable roof of the Toronto Skydome was the first structurally and mechanically successful example, but came with a very expensive cost, setting an upper bound value for the price of retractable roofs. After these attempts, several roofs managed to be structurally efficient and financially less expensive such as the cover of the Bank One Ballpark in Arizona, but the cost was still the highest among all the other roof-structure types.

From a structural point of view, retractable roofs are composed of moving rigid steel panels. Depending on the design, the roof either translates up or down or rotates.

Many problems have to be considered during the design such as the enormous weight, stability and rigidity of the moving roof panels as well as their discontinuity. The acceleration and deceleration of the movement should also be well studied to account for the dynamic loads on the structure. Due to the complexity of the system, the retractable roof system may require the analysis of up to 1500 load cases, 15 times more than the number required for the stadium itself. [k]

The construction process is very critical for this kind of roofs and the design decisions often rely on the erection methods that are to be used.

An example of retractable roof structures is the cover of the Miller Park in Wisconsin.

Figure XLV: Miller Park's retractable roof



CONCLUSION:

Looking only at the current approaches for stadium design and construction, one would wrongly think that they are new and belong to the latest couple of centuries. This will change if we focus on the Colosseum and Roman engineering. Romans are not mistakenly regarded as the finest engineers and architects. Many structures they left behind prove their innovations in civil engineering and particularly stadium design. The Colosseum, their greatest achievement in amphitheaters construction, is regarded as the mother of all Stadiums. It integrated all their architecture, mathematics, social, management and engineering knowledge; the same knowledge used in our current days. They had the ambition and intuition to push innovations in the use of materials and structural elements, but they didn't have the means of scientific theories to understand them. However, it was not an obstacle in their work as they intuitively exploited to the maximum the materials they already had as well as the structural elements and materials they invented. If we compare the Colosseum with the stadiums in our current days, it is obvious that the architectural design, requirements for the best viewing, fast access and exit, comfort of the spectators during the hot sunny days, the need for cost effectiveness and rapidity of construction are similar. The machinery used during the erection and the management process are also similar. What can be regarded as evolution in the stadium design and construction are the advancements brought to the materials and the understanding of structural behavior starting the nineteenth century. Several structural elements were invented since then, however the frame is still in our current days, the mostly used for the seating area. As in the Colosseum, the use of structural frame helps a better spreading of the loads in the ever growing stadiums base. This only shows that the approach followed to structural design these monuments have never evolved but only the tools. These tools include the new and better quality materials. Even in the case of roof design, some modern approaches used, mimic the cable supported awning of the Colosseum. Looking at more than 2000 years of stadium design and construction, some people would feel that no drastic evolution has occurred, others would think totally the opposite. In any case no one can deny that the spirit is still the same.

GLOSSARY

- 1- Amphitheaters: Theaters in the round; amphitheater means “ around” in Greek [2]
 - 2- Arena: Derived from the Latin word for ‘sand’ or ‘sandy land’ [2]
 - 3- Studies made, have shown that the Colosseum is not an exact ellipse as was believed but a pseudo-ellipse formed by the conjunction of many circles. Check:
<http://www.the-colosseum.net/architecture/ellipsis.htm>
<http://www.the-colosseum.net/ita/architecture/ellipse/schema%20geom.htm>
 - 4- *architectus*: Name of the architect-engineer in the Roman Empire in charge of the design and sometimes the construction
 - 5- Tuff: a sedimentary stone made essentially of calcite, deposited by calcareous waters. Its color is whitish, slightly yellow or reddish. It can stand a pressure of 226/298 Kg/cm² depending on its quality [2]
 - 6- Tuff: a stone produced by the cementing of volcanic material fallen after eruptions. Its color is gray, yellowish, greenish or brown. It is used in the preparation of special cements and as a building stone. [2]
 - 7- Awning or velarium: fabric canopy, supported by masts, ropes and pulleys stretched to protect from the sun. [2]
- a- Vitruvius: A practicing Roman architect, arms expert and hydraulic engineer. Lived during the 1st century A.D. He wrote several books on architecture and engineering such as *De Architectura* and *Ten books on Architecture*. The second one is his most famous book and the basis for all historians and engineers who want to understand Roman engineering. In it he offers advice on specifications, design, cost factors, functionalism and aesthetics [e]. He also touches all the aspects of Roman civil engineering and illustrates the good and the bad. [e]

REFERENCES

Books and journals:

- [a]: Venerable Bede (c. 673-735)/see also [2]
- [b]: Hans Christian Andersen / see also [2]
- [c]: History of building, Bowyer Jack
- [d]: Roman builders, Rabun Taylor
- [e]: Vitruvius, architect and engineer, Alexander McKay
- [f]: The Master Builders, Cowan.
- [g]: Stadia: A Design and Development Guide, Geraint John & Rod Sheard
- [h]: The ancient engineers , De camp
- [i]: article by Benjamin Herring , CONSTRUCTOR magazine, issue September 2002
- [j]: article by Norbert Delatte , Journal of Professional Issues in engineering education and practice/ July 2001/ 109
- [k]: Master of Engineering Thesis 2001, Miller
- [l]: The Architecture Stadium of Mass Sport, Michelle Provoost
- [m]: Engeniera Romana, Guiseppe Cozzo
- [n]: Roman building: Materials and techniques, Jean Pierre Adam
- [o]: Architectural technology up to the scientific revolution, Robert Mark
- [p]: Building Construction Before Mechanization, John Fitchen

Web references:

- [1]: http://www.steelrep.com/News___Info/HISTOR_1/histor_1.HTM
- [2]: <http://www.the-colosseum.net>
- [3]: <http://www.simons-rock.edu/~wdunbar>
- [4]: <http://www.arena-stadium.eu.org/2500-ans-histoire/4-contemporain/4-architecture.html>
- [5]: <http://millerpark.onmilwaukee.com/photos.html>
- [6]: <http://www.2020site.org/rome/>
- [7]: <http://myron.sjsu.edu/romeweb/ENGINEER/art1.htm>
- [8]: <http://www.crystalinks.com/romearchitecture.html>
- [9]: <http://www.pbs.org/wgbh/nova/colosseum/>
- [10]: http://www.kent.k12.wa.us/curriculum/soc_studies/rome/Colosseum.html
- [11]: <http://www.bluffton.edu/~sullivanm/romancolosseum/romancolosseum.html>
- [12]: <http://web.kyoto-inet.or.jp/org/orion/eng/hst/roma/colloseu.html>
- [13]: <http://www.sfo.com/~csuppes/Olympics/misc/index.htm?../1936Berlin/index.htm>
- [14]: http://lilt.ilstu.edu/bekurtz/roman_architecture.htm
- [15]: http://cee.wpi.edu/ce1030_b02/structures/history.pdf.(Structural Engineering: A historical Perspective, Prof. P. Jayachandran)
- [16]: <http://inventors.about.com/library/inventors/blconcrete.htm>
- [17]: http://www.tf.uni-kiel.de/matwis/amat/def_en/kap_5/advanced/t5_1_4.html
- [18]: http://www.ukans.edu/history/index/europe/ancient_rome/E/Roman/Texts/secondary/SMIGRA*/Amphitheatrum.html

- [19]: http://lilt.ilstu.edu/bekurtz/roman_architecture.htm
- [20]: http://www.rpi.edu/~grivad/education/tutorial/t_why.html
- [21]: <http://myron.sjsu.edu/romeweb/ENGINEER/art1.htm>
- [22]: www.rpi.edu/~grivad/education/tutorial/t_roman2.html
- [23]: <http://www.sfo.com/~csupes/Olympics/misc/index.htm?../1936Berlin/index.htm>
- [24]: <http://members.iinet.net.au/~mmckdav/images/france10.jpg>
- [25]: <http://www.columbia.edu/cu/gsap/BT/DMES/TIMELN/pontiac/pontiac.html>