

City-Car: Optimizing vehicle and urban efficiencies through a shared adaptive platform

by

William Lark, Jr.

B.S. Mechanical Engineering
Massachusetts Institute of Technology, 2003

SUBMITTED TO THE DEPARTMENT OF MEDIA ARTS & SCIENCES IN PARTIAL
FULFILLMENT OF THE REQUIREMENTS FOR THE DEGREE OF

MASTER OF SCIENCE IN MEDIA ARTS & SCIENCE
AT THE
MASSACHUSETTS INSTITUTE OF TECHNOLOGY

JUNE 2005

©2005 William Lark, Jr. All rights reserved.

The author hereby grants to MIT permission to reproduce
and distribute publicly paper and electronic
copies of this thesis document in whole or in part.

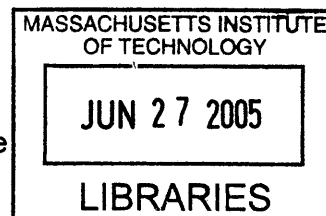

Signature of Author: _____
Department of Media Arts & Sciences
May 6, 2005

Certified by: _____
William J. Mitchell
Professor of Architecture and Media Arts and Sciences
Academic Head, Program in Media Arts and Sciences, MIT Media Lab
Thesis Supervisor

Accepted by: _____
Andrew B. Lippman
Chair, Departmental Committee on Graduate Students

ROTCH

City-Car: Optimizing vehicle and urban efficiencies through a shared adaptive platform.

by

William Lark, Jr.

Submitted to the Department of Media Arts & Sciences
on May 6, 2005 in Partial Fulfillment of the
Requirements of the Degree of Master of Science in
Media Arts & Science

Abstract

Research focused on developing an innovative, yet simple automobile platform that maximizes its efficiency through shared convenience. Work was initially put into studying both current vehicles and urban architecture, in order to understand how their relationship could advance contextual awareness, social interaction, and efficient allocation of resources. Through support of General Motors and Gehry Partners, a multidisciplinary team of research students collaborated to produce dozens of design iterations of the urban vehicle. The models were designed through parametric computer aided design program, Catia®, and rapidly prototyped through the use of three-dimensional printers, Stratasys® and Z-corp®. Further studies of the designs lead to the development of a concept vehicle, “City-Car” – a convenient, efficient, and chic addition to public and private transportation in the city. City-Car is an adaptive shared vehicle that provides a fun driving experience in dense areas. Multiple design iterations of the City-Car were created to operate in a shared vehicle system. The *Flex* City-Car is a battery-powered dual motored vehicle able to reposition its rear powertrains to occupy a quarter less space when parked and 44-percent less individual net space when linearly stacked compared to its footprint while driving. All City-Cars promote a share a platform that can be accessed on demand for charging, networking, and cleaning to accommodate the way people live today. An urban case study of Cambridge, Massachusetts, revealed that a one to fourteen user ratio shared vehicle system using the City-Car is able to recuperate over one-hundred acres of previously paved parking surfaces when twenty percent of driving commuters forfeit their vehicles.

Thesis Supervisor: William J. Mitchell

Title: Professor of Architecture and Media Arts & Sciences

Thesis Committee

Advisor:

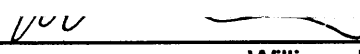

William J. Mitchell
Professor of Architecture and Media Arts and Sciences
Academic Head, Program in Media Arts and Sciences, MIT Media Lab
Thesis Supervisor

Reader:

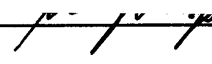

Sanjay E. Sarma
Associate Professor of Mechanical Engineering
Former Chairman of Research and Co-Founder of the Auto-ID Center, MIT

Reader:



Lawrence Sass
Assistant Professor of Architecture
Professor of Computational Design and Fabrication, MIT

Reader:



Axel Kilian
Dipl. Ing.
PhD Candidate in Computation, Department of Architecture, School of Architecture and
Planning, Massachusetts Institute of Technology

Acknowledgements

I would like to take a brief moment to thank those near to me who have given tremendous support through the past two years of my research.

Larry Sass, thank you for your continual sound advice and mentoring through my years at MIT. To Bill Mitchell and Ryan Chin, thank you for bringing me on board to such an exciting project. The work in our group has been both challenging and inspiring. Axel, Federico, Franco, Mitch, Peter, Philip, Retro, Susanne, and all other *Smart Cities* colleagues it has been a pleasure working with you. I have learned much from each of you and admire the contribution each of you brings.

To my parents, Marlene and William Lark, I want to say thank you for always being encouraging, constructive and loving role models. Joshua, thanks for being a genuine brother and a friend. Vanessa, you've given me true balance and I love you for your thoughtfulness and uplifting spirit. I love you all.

Finally, thank you to my Lord and Savior who has stayed beside me during trying times. Jeremiah 29:11

Table of Contents

Abstract	3
Thesis Committee	5
Acknowledgments	7
Table of Contents	9
Table of Figures and Charts	13
I Introduction	15
1. Methodology	17
1.1 Solution Space	17
1.2 Parametric Design	18
1.3 Physical Modeling	20
1.4 Design Support	20
II Backpacker	23
1 Design Solution	25
1.1 Accessorizing Precedents	25
1.1.1 iPod®	25
1.1.2 House	26
1.1.3 Humans	26
2. Shared Platform	27
2.1 Pyramid Diagram of Shared System	27
2.1.1 "City" – All use	28
2.1.2 "Residential underground dispenser" use	29
2.1.3 "Complex Extension" use	29
4.1.4 – "Home, Luxury" use	30
2.2 Pyramid Revision	30
3. Design Goals	33
3.1 Footprint	33
3.2 Weight	34
3.3 Transform Time	34
3.4 Range	34
3.5 Lithium-Ion Battery	35
3.6 Dispenser	35
4. Design Iterations	37
4.1 Two-4-Cube	37
4.2 Helmet	38
4.3 SaddleBag	40
5. Backpacker Evaluation and Evolution	42

III City-Car	45
1. Characteristics	47
1.1 Convenient	47
1.2 Urban	47
1.3 Networked	48
1.4 Chic	48
1.5 Adaptive	48
2. Design iterations	49
2.1 Shopping-Cart-Car	49
2.2 LoxBox	50
2.3 G-hopper	52
2.4 B-Carr	54
3. Analysis of Design iterations	56
4. Final Design	61
4.1 Vehicle components	62
4.1.1 Motor-Wheel Assembly	63
4.1.2 Actuated Rear Drive	64
4.1.3 Chassis	65
4.1.3.1 Safety Cage	65
4.1.3.2 Dynamic Cabin	67
4.2 Specification Comparison	68
5. System Analysis	71
5.1 Traffic Patterns	72
5.2 Providing Vehicles for Peak Hours	76
5.3 Cambridge Case Study	77
IV Conclusion	85
Thesis Committee	87
References	91

Table of Figures and Charts

Figure 1: Solution space hierarchical diagram	17
Figure 2: smartfortwo® blueprint	18
Figure 3: Parametric ergonomics study	18
Figure 4: 3-D reach envelope study	19
Figure 5: 3-D modeled comfort zone & reach envelope comparison	19
Figure 6: Rapid prototyped models of ergonomic studies	20
Figure 7: Foam-core constructed models of various ingress/egress solutions (Axel Kilian)	20
Figure 8: Smart Cities group collaboration	21
Figure 9: iPod® Accessories	26
Figure 10: Diagram of various shared systems	28
Figure 11: Backpacker accessorizing and servicing in dispenser (Andres Sevtsuk)	28
Figure 12: Backpackers linearly parked underground (Andres Sevtsuk)	29
Figure 13: Backpackers adjacently parked to building	30
Figure 14: Revised diagram of various shared systems	30
Figure 15: Diagram of typical urban traffic	31
Figure 16: Single axis snap on motion	34
Figure 17: Backpacker accessorizing and servicing dispenser (Andres Sevtsuk)	36
Figure 18: Two-4-Cube profile	37
Figure 19: Two-4-Cube multiple views	37
Figure 20: Various commuting modes for the <i>Two-4-Cube</i>	38
Figure 21: Isometric views of <i>Helmet</i>	38
Figure 22: Rendering of <i>Helmet</i> (rendering by Marcel Botha)	39
Figure 23: <i>Helmet</i> version of <i>Backpacker</i> in various accessorized scenarios (images by Philip Angus Liang)	39
Figure 24: <i>SaddleBag</i> version of <i>Backpacker</i>	40
Figure 25: <i>SaddleBag</i> accessories	40
Figure 26: Various combinations of <i>SaddleBag</i> accessories	41
Figure 27: Backpackers' profile	42
Figure 28: <i>Shopping-Cart-Car</i> (rendered by FrancoVairani)	49
Figure 29: <i>LoxBox</i>	50
Figure 30: <i>LoxBox</i> blueprints & 3-D printed studies (photographed by Peter Schmitt)	51
Figure 31: <i>G-hopper</i>	52
Figure 32: <i>G-hopper</i> repositioning rear drivetrain for multiple driving positions	52
Figure 33: <i>G-hoppers</i> linearly nested for tight parking	53
Figure 34: <i>G-hoppers</i> 3-D printed models	53
Figure 35: <i>B-Carr</i> (rendered by David Gerber)	54
Figure 36: Modular illustration of <i>B-Carr</i>	54
Figure 37: <i>B-Carr</i> Stacked at dispenser (rendered by David Gerber)	54
Figure 38: Profile view of stacked <i>B-Carrs</i> (rendered by David Gerber)	55
Figure 39: Multiple views of <i>B-Carr</i> (rendered by David Gerber)	55

Figure 40: Free-body-diagram of <i>G-hopper</i> actuator	58
Figure 41: Free-body-diagram of <i>B-Carr</i> actuator	58
Figure 42: Free-body-diagram of newly proposed actuator	59
Figure 43: <i>Flex</i> City-Car blueprints	61
Figure 44: Stacked <i>Flex</i> City-Cars	61
Figure 45: <i>Flex</i> car banking through turn	61
Figure 46: <i>Flex</i> City-Car solution space	62
Figure 47: <i>Flex</i> car motor-wheel	63
Figure 48: Hubless Wheel designs (<i>Brian Chan</i>)	63
Figure 49: Hubless Wheel prototype (<i>Brian Chan, Patrik Künzler, Olumuyiwa Oni, and Retro Poblano</i>)	63
Figure 50: Festo® fluidic actuator	64
Figure 51: Fluid actuator and gear pump design	64
Figure 52: <i>Flex</i> chassis platform	65
Figure 53: Stress analysis on safety cage	65
Figure 54: Force/Displacement study	66
Figure 55: Dynamic Cabin renderings	67
Figure 56: Diagrammatic illustration of dynamic cabin compared to standard vehicle	67
Figure 57: Various versions of City-Car	69
Figure 58: Typical traffic flow patterns	72
Figure 59: Arial of Cambridge, MA	77
Figure 60: Recovered surface area from three dispensers	82
Figure 61: Recovered surface area through all of Cambridge, MA	83
Chart 1: Battery technology comparison	35
Chart 2: Specifications for various <i>Backpacker</i> models	42
Chart 3: Specifications of various City-Car models	56
Chart 4: Analysis of various actuators used to reposition vehicles	60
Chart 5: City data	77
Chart 6: Car specifications	78
Chart 7: Parking comparison	78
Chart 8: Dispenser metabolism	79
Chart 9: Urban implications – surface area needed (per 1000 users)	80
Chart 10: Surface area saved by use of City-Car (per 1000 uses)	81
Chart 11: Surface area saved / recovered (per percentage of population adoption)	83

I Introduction

The automobile has provided unprecedented mobility, allowing access to resources inside and outside of the city environment. Although automobiles have and will continue to improve in performance, they are still responsible for many negative side effects, some of which are pollution, traffic jams, injuries and deaths of pedestrians and vehicle occupants, and excessive consumption of resources for operation. Traffic delays alone cost the US public up to 100 billion dollars a year (Euler and Robertson, 1995). Improvements to address these issues have been few and insufficient. Vehicles continue to grow in footprint, weight, and volume, while they consume more resources. This “super-sized” mentality is inefficient and has taken a toll on the urban infrastructure – daily traffic jams are the normality in major cities. Parking is limited and therefore expensive. Idle vehicles occupy a significant percent of precious real estate while parked. Even more problematic, cars contribute to hostile social interactions, as drivers fend for themselves for the limited resources of space, energy, and time. The price paid for mobility is unacceptable in an urban environment, where positive social interaction should be encouraged, not clouded by aggressive gluttony.

This vehicular battle for time and space has been approached by simply adding more resources—increasing the number of parking structures and constructing mega six-

lane highways. However, these solutions simply mask the problems.

A more promising strategy is to fundamentally rethink the relationship of the car to its user and the city. Design solutions may be achieved through redefining relationships and behaviors of vehicle ownership, by starting with a design that strips the vehicle down to its bare necessities. Instead of hauling around every possible feature, an innovative car design should provide the user with a platform that performs the essential tasks for the commute, yet is adaptive to accommodate changing needs. Reducing the vehicle architecture to a minimum improves its efficiency by conserving weight, consuming less power, and reducing occupied landscape.

The following research is framed in the *Smart Cities* group's *Concept Car* development with General Motors and Frank O. Gehry's architectural firm. Unique design approaches to address these mobility concerns were tackled through the collaboration of MIT and Gehry while GM provided engineering and design support for the production of a concept show car in the upcoming years. While this concept vehicle will address urban, environmental, and social conflicts, it will also serve as a springboard for various Media Lab innovations addressing contextual awareness, human interaction, mass customization, and connectivity.

1. Methodology

A critical step in concept car design is the methodology. The design problem was addressed four ways. First, the solution space was mapped to give the research a context to work within. Second, parametric CAD modeling validated design iterations. Creating intelligent 3-D models proved to be a supportive tool, which saved significant time as the design process evolved. Complementary to the digital models, physical modeling, through the use of various media, provided further insight than which could be gained from digital modeling alone. Last, experienced engineers and architects within General Motors and Gehry Partners provided necessary design support.

1.1 Solution Space

A solution space must provide certain constraints that allow the final product to meet its goals. The solution space provides the designer with rules to follow. One of the first tactics to define these rules is to breakdown the problem, in this case the car, into manageable subcomponents (see Figure 1).

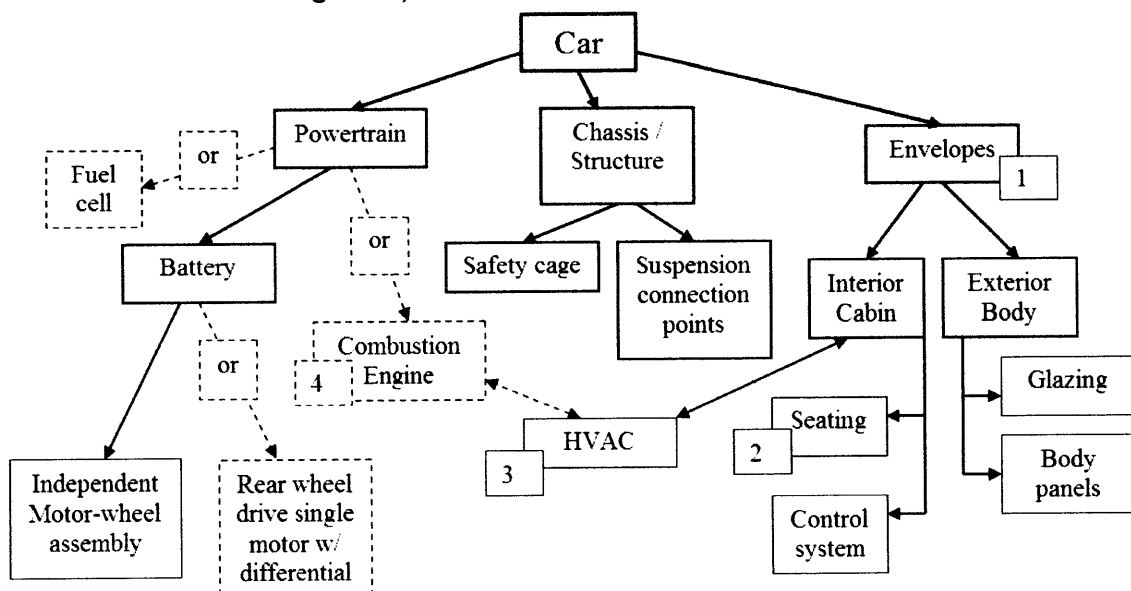

Figure 1: Solution space hierarchical diagram

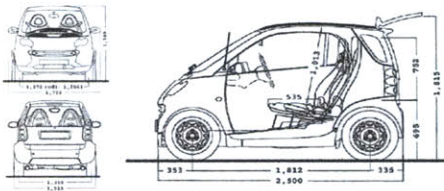

Figure 2: smartfortwo® blueprint

One of the largest constraints that lead to a significant design challenge is efficient packaging. For that reason, we can set our first two main geometric constraints – the vehicle’s footprint [1] and the occupants [2]. The passengers present a non-variable constraint, whereas the footprint while parked, although variable to a degree, will initially be set at the size of a *smartfortwo*® car, 98 by 60 inches. (see Figure 2). The car’s drivetrain can be approached through multiple platforms, such as battery, fuel cell, internal combustion, or a hybrid of these. Although current battery technologies power density does not compare to that of gasoline, fully electric vehicles present a number of benefits. Not only does the electric-drive eliminate local pollutants, but its battery provides a flexible geometry which is essential for the tight packaging solution. Nevertheless, the vehicle’s platform may still left open to combustion engine hybrid options or even fuel cell, once the technology is appropriate.

1.2 Parametric Design

Establishing a set of design rules through the solution space is the first step in creating geometric parameters. A set parameter can be simple as the width of a car seat or the volume of the motor that moves it. Understanding how to manipulate these parameters becomes extremely important when optimizing packaging in such a small volume, since various components may be in conflict for space and/or need to maintain specific spatial relationships. For example, in current vehicles the cooling system [3] and engine block [4] are placed adjacent to each other since the engine directly drives the fan belt. This physical constraint can be expressed as a spatial parameter. In addition, geometric

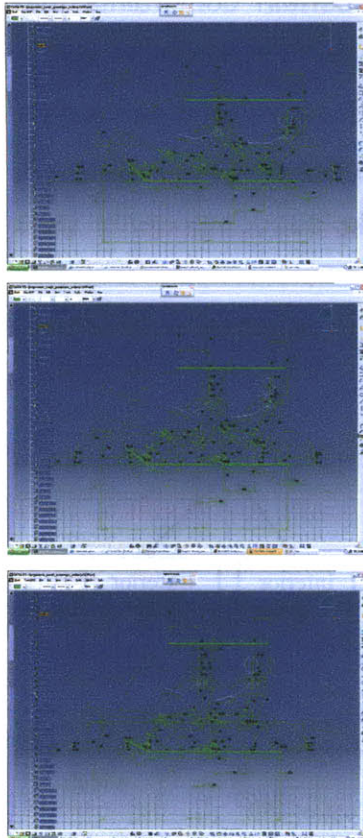

Figure 3: Parametric ergonomics study

parametric relationship exists because as the engine size increases so must the cooling system that supports it.

Understanding these relationships and formulizing them in a controlled 3D model allows the designer to not only stay true to established engineering rules, but to also experiment with various designs quickly without rebuilding each iteration. Parametric modeling using Catia® software provided intelligent 3D models that allowed for design flexibility, while maintaining engineering validation.

Some of the designed parametric models, like the ergonomic model in Figure 3, established rules for interior constraints. This model provided an interior profile as a barrier to design the rest of the vehicle around. In many CAD models, the vehicle was developed from the occupant outward since they are non-variable constraints. Human constraints such as head and leg room, and arm reach are parametrically tied together to display the minimized envelope when variables such as the seat angle are changed. As the occupants sit more upright into utility style seating, the ground clearance and head room are increased to accommodate rougher rides. Accordingly the envelope is tightened when occupants sit more reclined for higher speed tightly suspended performance driving. The resultant envelope establishes a boundary to design the rest of the vehicle around. Other parametric 3-D models explored more refined constraints, such as three-dimensional reach envelopes (see Figure 4) to guarantee all designed interior controls are easily accessible.

Also, minimal comfort zones are important to consider in small vehicle design. Additional CAD models were also



Figure 4: 3-D reach envelope

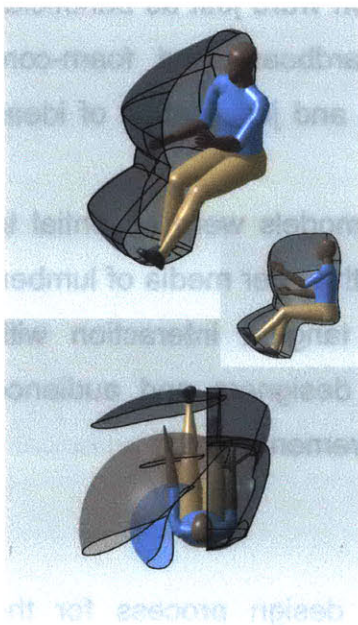

Figure 5: 3-D modeled comfort zone & reach envelope comparison

established to make sure the average occupant does not feel cramped in the vehicle design (see Figure 5).

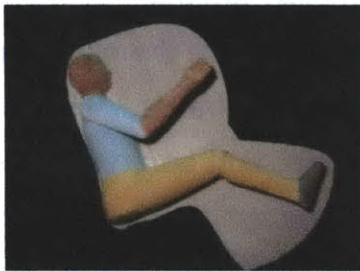
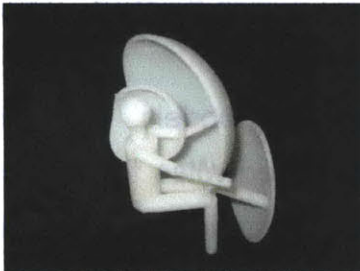

Figure 6: Rapid prototyped models of ergonomic studies



Figure 7: Foam-core constructed models of various ingress/egress solutions

1.3 Physical Modeling

While parametric 3D CAD modeling offered a valuable tool for creation and visualization of ideas, physical construction is just as important to comprehend the concepts. Physical modeling for this design is approached in three ways – Rapid prototyping, tenth and fifth-scale modeling, and full scale construction for interactive studies. Rapid prototyping through the use of media lab 3D-printers (see Figure 6) has proven to be a valuable resource for expedient validation of concepts. CAD models can instantly be visualized and manipulated in 3D space for instant critique.

Although using sophisticated rapid prototyping machines, *Stratasys®* and *Z-Corp®*, provided useful models, the use of more crude methods of construction were just as beneficial. Traditional studio methods of cardboard and foam-core assembly promoted rapid building and justification of ideas (see Figure 7).

Finally, full scale constructed models were essential to test human interfaces. Working with larger media of lumber, foam, and metal afforded fully tangent interaction with conceptual models, allowing the designers and audience better interaction to facilitate improvements.

1.4 Design Support

The strongest aspect of the design process for the vehicle is the multidisciplinary collaboration in the studio. The collaboration works in two main areas, internally and

externally. Internally, students from various academic backgrounds (mechanical engineering, architecture, aero/astronautics, computer science, undergraduate, graduate, and PhD level) add value through unique design perspectives (see Figure 8). Collectively the strengths of each discipline provide the workspace with broad intellectual power and allow efficient presentation and approach of problems. Externally the design has been supported by experts in numerous fields. Direct interaction was maintained with General Motors and Gehry Partners. Each collaborator provides insight on issues of manufacturing, technical feasibility, urban context, and user habits. Having access to such valuable resources made possible to validate the design as they evolved.

As in any design project, it becomes difficult to truly quantify what a proper solution is. Expert designers such as Wayne Cherry of GM and James Glymph of Gehry Partners interacted in the concept development process, evaluating and providing feedback for each revision. This cyclical process of research, design, presentation, critique, and modification continued through the following research.



Figure 8: Smart Cities group collaboration

II Backpacker

The Backpacker vehicle looks at minimizing the excessive use of resources by providing the user with the bare essentials for day-to-day travels, while still affording architecture that supports personal accessorizing. These accessories allow for expansion in storage, entertainment, technology, styling, and recreation. This platform contrasts the sports utility vehicle approach of lugging around every feature at all times, when in reality they are occasionally used. Although an SUV may provide the convenience of a do-all vehicle, most of the time this convenience results in inefficient use of power and space. The Backpacker vehicle attempts to solve this paradox by providing a truly simple, efficient, and unselfish vehicle for everyday use, yet maintaining a platform for integrated expansion with the ease of throwing on a backpack or simply changing clothes.

1. Design Solution

On any given day the average commuting vehicle transports only about 1.2 passengers and a couple of personal items. However in today's American society, large sedans and sport-utility-vehicles readily handle tasks that could be managed by significantly smaller means of transportation. Nevertheless, convenience seems to be a recurring defense for today's large vehicle.

We can begin by essentially changing the way we address the user needs and habits in order to provide a parallel convenience to that of larger vehicles.

It is clear that automobile users have multiple needs. Some need storage, some need entertainment, and some need recreational enhancement. Yet they do not need to use these features all of the time. The Backpacker vehicle proposes a simplified platform that decouples the automobile from all of these excessive components. Instead the vehicle can easily be accessorized, customizing to the user's unique needs. To further understand the use of accessories we can explore existing precedents.

1.1 Accessorizing Precedents

There are multiple examples outside of the vehicle realm that serve as exemplary models for accessorizing. Consumer products and human behavior show how an accessorizing platform may flourish.

1.1.1 iPod®

The Apple iPod® reflects the current example of a personal accessorizing product. In its simplest form it provides a convenient music player. However, as do other personal electronics, such as cell phones, it provides a sophisticated foundation for expansion. Unique headphones, remote

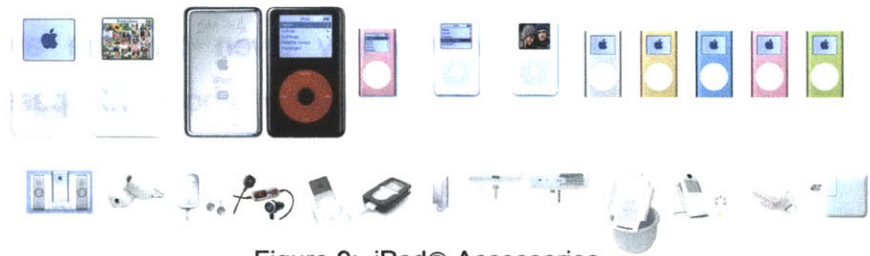

Figure 9: iPod® Accessories

controls, mini stereo systems, laser pointers, stylish sleeves, car adaptors, radio functionality, belt clips, and arm band are just some examples of accessories that add to the iPod's® functionality and character (see Figure 9).

1.1.2 House

The roof and walls of a house that give shelter provide another example of satisfying an essential need. Nevertheless, homes illustrate an extreme example of accessorizing. Pillow shams upon bed sheets on top of mattresses – not only are the homes themselves accessorized, but the accessories themselves are expanded with more features. The modern home presents such a flexible platform that there are multiple layers to accessorize.

1.1.3 Humans

One of the most accessorized entities that may be overlooked, is the human body. The human body by itself contains everything for daily functioning. Still it continues to be complemented with a growing number of accessories. Multiple layers of clothing give added protection from elements, watches provide information, cell phones are used for communication, and jewelry enhances the aesthetic perception.

The naked body, the home, and iPod® exemplify efficiency, containing the fundamentals basic functioning, while still encouraging interchangeable accessories for adaptation.

The same may be done with the *Backpacker* vehicle platform to add functionality and character to simple commuting means.

2. Shared Platform

Although reducing excessive functionality on the core vehicle of the *Backpacker* may provide a more efficient energy and material use, isolated vehicle efficiency is not enough. Changing the *Backpacker's* ownership to a publicly shared platform can greatly reduce used resources of material and space. Current models such as ZipCar® demonstrate how a small number of vehicles can serve hundreds of users. The cars stay in motion during a greater percentage of the day transporting people from location to location and spend less time inhabiting valuable city real estate. There are multiple ways in which the *Backpacker* could be shared.

2.1 Pyramid Diagram of Shared Systems

The following pyramid (see Figure 10) provides a solution space to illustrate the multiple ways in which the *Backpacker* system could be shared. Four managed ownership models may be necessary to address unique user needs. The largest platform for the *Backpacker* would complement public transportation by serving a vast number of urban users (City, All). Smaller sharing platforms may cater to less populated areas in residential communities or even niche home use.

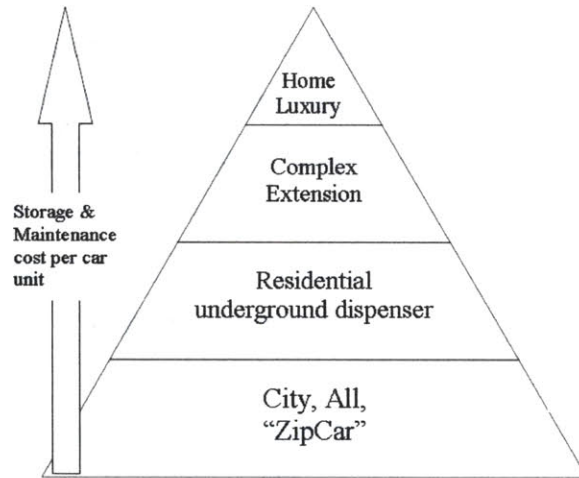

Figure 10: Diagram of various shared systems

2.1.1 (Bottom Tier) – “City, All”

Think of the shared model on the bottom tier as an airport luggage cart. Tightly compacted vehicles are parked in a dispenser that can be rented by anyone at anytime. When the user needs one, he or she simply takes the first one in line, completes their errands, then returns the car to the end of the stack of either the same or another conveniently located dispenser. The dispenser serves numerous roles. Not only will it house the parked *Backpacker* vehicles, but it will also serve as the accessorizing enabler. *Backpackers* will be dressed and undressed as they exit and enter (see Figure 11). The dispenser will also provide organized storage for the unused accessories. While parked in the city dispenser, common maintenance to the vehicle would be automated, such as charging and cleaning.

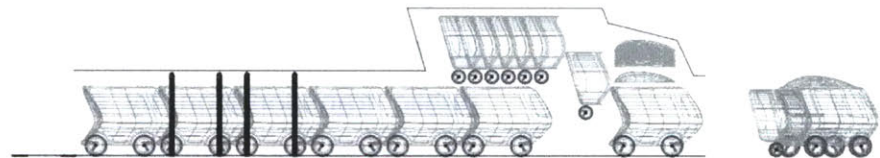

Figure 11: *Backpacker* accessorizing and servicing in dispenser

2.1.2 (Middle Tiers) – “Residential underground dispenser”

Incorporating *Backpacker* vehicles into the lower structure of the building could drastically change apartment architecture. Designers are currently inhibited by regulations that require significant space be dedicated to parking complexes. However, if we rethink the current models that provide parking structures for individual vehicles of apartment residents and instead provide every resident with the ability to rent vehicles provided by the complex, we can then introduce a space efficient shared valet service. *Backpacker* vehicles could be stored underground cheek to cheek (see Figure 12), ordered and customized as the resident leaves their room, and delivered to the resident at the front door. As in the previous model, the residents would all share the base vehicles. Similar to an airport luggage cart, when a resident needs a vehicle he or she simply uses the first car in line. This would also speed up the valet service significantly since there is no longer a search for an individual car.



Figure 12: *Backpackers* linearly parked underground

2.1.3 (Middle Tiers) – “Complex Extension”

The second tier in the pyramid also represents a transportation platform for apartment and condo complexes. However, individual *Backpacker* vehicles would be assigned and parked adjacent to each apartment. While parked the vehicle would serve as a small extension to the room, providing a seamless transition from home to travel (see

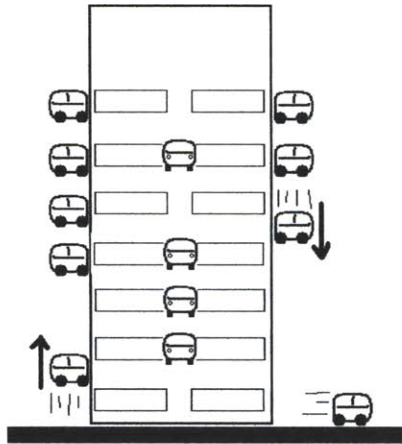

Figure 13: *Backpackers* adjacently parked to building

Figure 13). Large external accessories would instead be owned by the complex and automatically added to the vehicle as it departs from the building. In this model the vehicles are leased in accordance with the apartment rental. Accessories are shared among the complex residents.

2.1.4 (Top Tier) – “Home, Luxury”

Less utilized yet still available is the *Backpacker* for the individual home. One or more naked *Backpacker* vehicles could be stored in a home garage that would also house the accessories. Since convenience is always a factor, accessorizing and stripping the large components would need to be automated by robotics embedded in the garage. To simplify the mechanics, single axis actuators would dress and undress the vehicles. Most likely this model will fit a niche market because these automated garages, which only serve a couple vehicles, may be costly.

2.2 Pyramid Revision

Looking at the various models in the pyramid, we can begin to delve even further into the ownership and usage of the *Backpacker*.

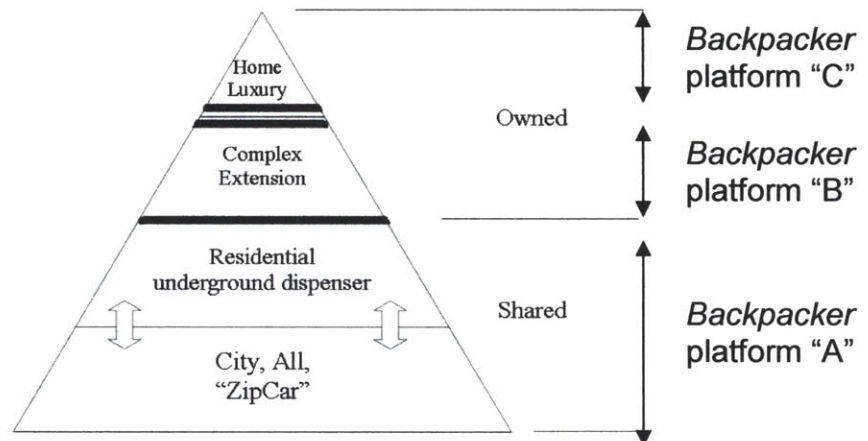

Figure 14: Revised diagram of various shared systems

The revised pyramid (see Figure 14) illustrates the ownership models for the various *Backpackers*. In the top two tiers of the pyramid, each *Backpacker* vehicle would be owned or leased. Also, each requires unique architecture for their various functions (platforms B & C). However, all vehicles in the bottom tiers are uniformly shared. Since vehicles in both the city dispensers and residential underground dispensers can be used in the similar manner, a single *Backpacker* platform could be used in both (platform A). If the vehicle maintenance is standardized, the same *Backpackers* can dwell both in the city and in surrounding neighborhoods. Sharing vehicles this way can maximize efficient usage and provide vehicles to compliment travel patterns (see Figure 15)

(1)The majority of the vehicles will dwell at the residences during the early mornings to provide transportation for commuters. (2)During mid-day the majority of *Backpackers* are in the city, the vehicles can be used by anyone in the city to run errands in local circulation. (3)Finally as the day ends the flock will disperse once again to their perspective residences, ready to be used again the next day.

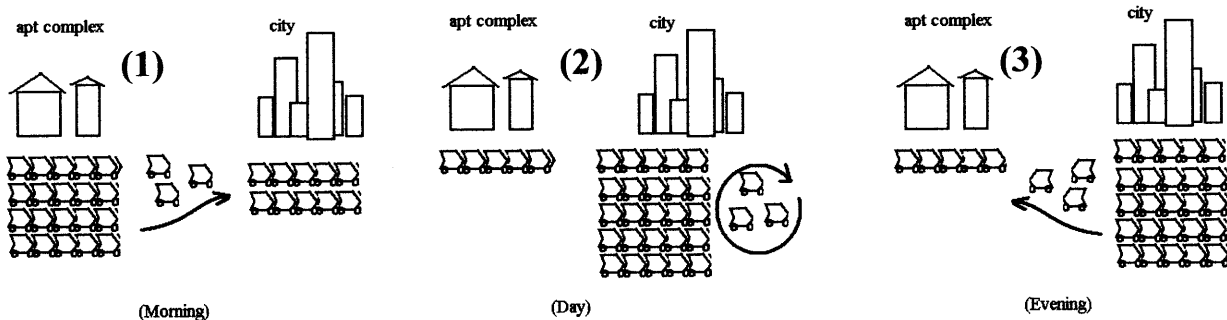

Figure 15: Diagram of typical urban traffic

3. Design Goals

On a large scale the *Backpacker* addresses inefficiencies by sharing its resources. Individually, the *Backpacker* embodies minimal characteristics to consume fewer resources of energy and space.

Trips made in shared vehicle platforms are normally shorter in distance. Also, shared platforms require maintenance and replenishing of energy, which is typically not expected to be maintained by its users. Implementing an all electric power platform presents numerous benefits in a shared vehicle system. Various schemes to recharge the *Backpackers* can be used at parking stations. An electric platform requires relatively less infrastructural needs by exploiting the city's power grid.

Also beneficial in an electric vehicle platform is the design flexibility it offers. Void of an internal combustion engine, the vehicle depends less on complex restrictive mechanical connections. This freedom gives the vehicle greater modularity, which is essential for a car like the *Backpacker* – needing to effortlessly adapt with accessories.

3.1 Footprint

Maintaining a small footprint will depend on two factors – required vehicle components and creative packaging. The first is addressed by minimizing the number of components of the *Backpacker* core. Think of the core as a luxury golf cart with extended range and advanced safety. The second factor, packaging, will primarily be addressed through CAD modeling. It is important to begin by defining non-variable constraints such as passenger occupancy, motor and battery

combinations for desired range and performance, and supporting systems.

3.2 Weight

Sustaining low vehicle weight is just as crucial to save resources since mass will dictate how much power is consumed on each trip. Without accessories the core vehicle of the *Backpacker* must remain under low. Keeping the center of mass extremely low to the ground is also important considering the vehicle's small footprint.

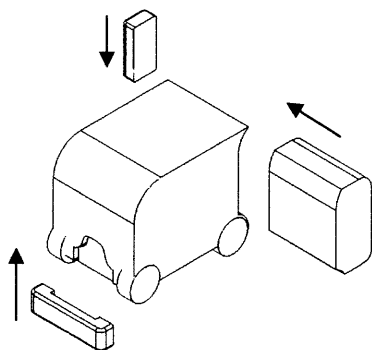

Figure 16: Single axis snap on motion

3.3 Transform Time

Keeping the time to add and remove accessories low is important to maintain convenience. Accessories must be added in a matter of seconds to measure up to the convenience of fully owned automobiles. The *Backpacker* does this by utilizing snap fit fixtures with single axis motion (see Figure 16).

3.4 Range

As we fundamentally rethink the daily patterns of the *Backpacker*, we can also rethink the acceptable range that the vehicle needs. Each time the vehicle is parked in the dispenser it is charged. This allows ample time to restore power and does not require the user to make frequent station stops. Also, the average commute distance is less than 50 miles one way with extreme cases over 70 miles. Considering average commuting distances and its ability to constantly charge while static, a range under 100-miles can now be considered acceptable.

3.5 Lithium-ion battery

Each Backpacker vehicle uses 18650 Lithium-Ion batteries as the main power source. Comparing battery technologies (see Chart 2) and current electric vehicle studies, the 18650 Li-Ion batteries appear to be the most resourceful because of their relatively higher energy density. Also, these smaller batteries are currently used in high volume in numerous smaller electronics applications, allowing their cost to be significantly lower compared to other Lithium-Ion models.

Specifications necessary to travel about 50 miles (rated for a 2000lbs vehicle)

Batter Type	Energy density Wh/kg	Power density W/kg	Weight kg (lbs)	Volume cu m (l)	Advantages	Problems
Lithium Ion	100	300	150 (320)	0.05 (50)	High energy density allows vehicle to stay light and provide greater range.	Expensive
Lead Acid	35	71	428.5 (900)	0.21 (210)	Reliable Relatively less expensive	Extremely Heavy
Nickel Cadmium	50	150	300 (630)	0.1 (100)	Relatively light weight	Expensive Requires forced air cooling
Nickel Metal Hydride	80	200	187 (412)	0.075 (75)	Relatively light weight	Expensive Requires forced air cooling
Lithium Polymer	155	470	82 (180)	0.032 (32)	Extremely light weight High energy density	Extremely expensive Relatively short life span (2-3 years)

Chart 1: Battery technology comparison

3.6 Dispenser

The vehicle dispensers serve as the primary homes for the *Backpackers*. Instead of homes, it may be even better to view the dispensers as hotels for the vehicles. Because the *Backpackers* operate in a system of vehicles, one-way travel is possible. Also, because any user may rent a *Backpacker* and store it again in any dispenser, over time vehicles will reside in various dispenser locations. Knowing that the vehicles randomly disperse eventually to a variety of dispensers, flexibility can be implemented into the design of each dispenser – some to serve simple services such as

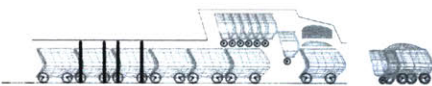

parking and charging, while others may park, charge, clean, and perform maintenance to the *Backpacker*. The functions of the dispensers can be divided up into three service criteria:

1. Frequent – services that allow the *Backpacker* system to operate on a daily basis, such as parking and charging.
2. Regular – services not needed during every park, however often enough to keep vehicle equipped. These services include cleaning and diagnostic check-ups.
3. Occasional – these dispensers will be sparsely populated because of their complexity. In addition to all of the previous functions, these elaborate dispensers will perform more complex operations such as under-the-hood inspection and maintenance operations – brake disc change, tire rotation, battery exchange. ...etc (see Figure 17).

Another important characteristic of the dispenser is its minimized profile. Not only must the *Backpacker* vehicle stay small, but so must the dispenser to save space. Accessory storage will embody the majority of the dispenser's space. Last, the design of the dispenser must be significantly scalable, able to accommodate both short and lengthy stacks.

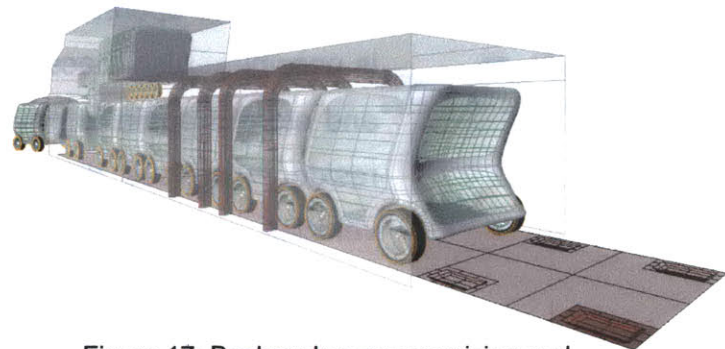

Figure 17: Backpacker accessorizing and servicing dispenser

4. Design Iterations

The following are some of the initial vehicle designs for the Backpacker. Although each addresses urban complications earlier established, they all take unique approaches by either supporting vast accessorizing or a reconfiguring platform.

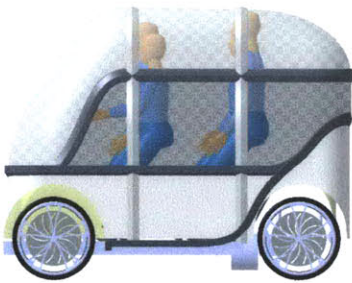

Figure 18: Two-4-Cube profile

4.1 *Two-4-Cube*

The *Two-4-Cube* (see Figure 18) provides interior flexibility to accommodate both two and four passenger configurations. Studies have shown that the average car carries 1.2 passengers at a time. However, many prefer to own four passenger vehicles for the occasional moments where more occupants are needed. The *Two-4-Cube* addresses this paradox by offering a comfortable compact vehicle for two that transforms its interior to accommodate four occupants for short periods of time in a semi-sitting position (see Figure 19). The *Two-4-Cube* may not serve as a suitable option for frequent travel of three or four occupants since the semi-seating position may not be comfortable for long periods of time.

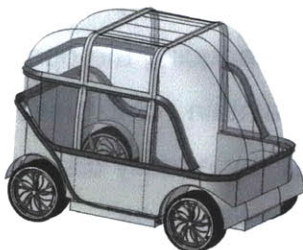
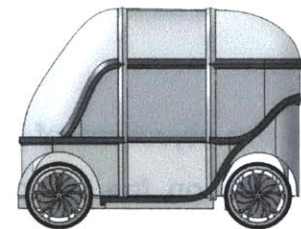

Figure 19: Two-4-Cube multiple views

The *Two-4-Cube* maintains a small footprint by increasing in height. Although it may be able to park in spots relative to that of a SmartForTwo® car, it is comparatively tall to that of an SUV to accommodate four occupants in a semi-sitting position.

The *Two-4-Cube's* structural frame is made of reinforced tubular steel members to protect its small volume. The middle horizontal bar is positioned above the driver's line of sight while sitting in the two-occupant configuration, and below while accommodating four.

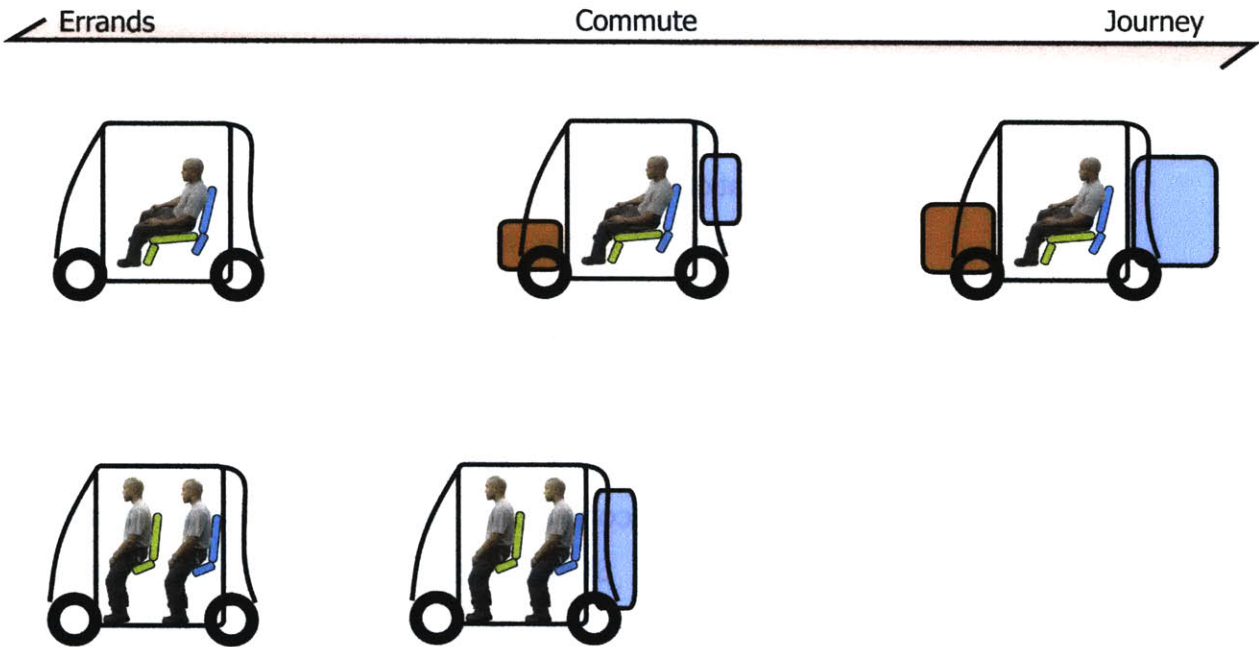

Figure 20: Various commuting modes for the *Two-4-Cube*

4.2 *Helmet*



Figure 21: Isometric views of *Helmet*

The “injection-molded car” – one of the objectives of the *Helmet* car was to reduce the part count on the vehicle. Imagine the majority of the vehicle being manufactured through simply one or two processes. What would this say about the vehicle architecture? One way to initially reduce the number of parts on the car’s body is to reduce the number of ingress/egress points to one. The *Helmet* (see Figure 21) has a single front ingress/egress area allowing the vehicle’s body to be composed of only two main components, the shell and the door. Reducing the openings on the car also allows the car to maintain robustness and behave as a singular shell or “helmet” by equally distributing impact forces throughout all of the vehicle’s walls.



The *Helmet* car embodies a simple rear-wheel drive with a single motor and clutch system located below the rear passengers. Batteries are located within the base and under the front occupant seating.

The *Helmet* series of *Backpackers* has an extremely simple design yet can be used to add on components for improved performance and range.

Figure 22: Rendering of *Helmet*

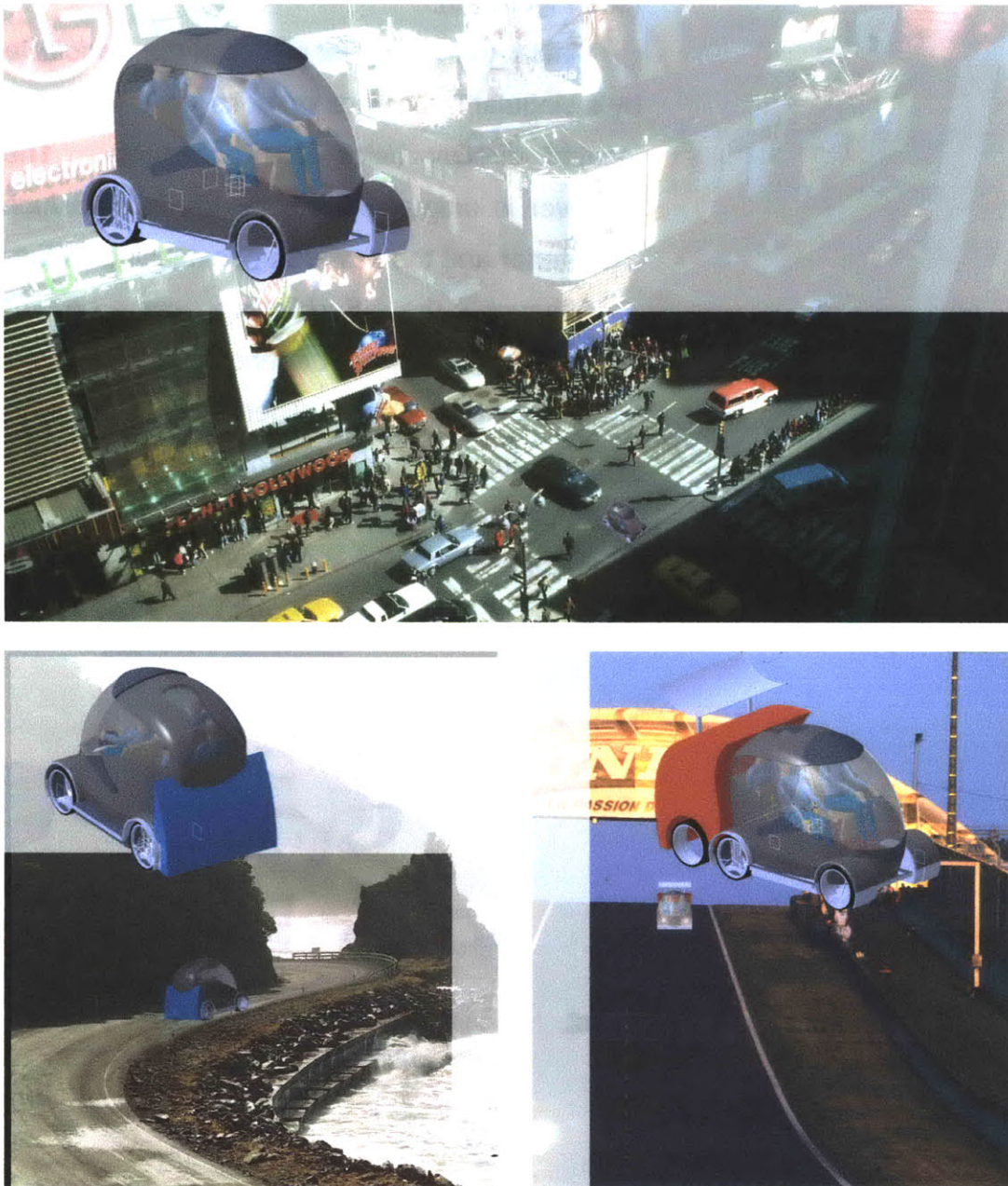

Figure 23: *Helmet* version of *Backpacker* in various accessorized scenarios
Undressed for common commutes (Top), added battery pack for longer range trips (Bottom-Left), and improved performance with additional powertrain (Bottom-Right)

4.3 SaddleBag



Figure 24: SaddleBag version of Backpacker

Evolving from the *Helmet*, the *SaddleBag* (see Figure 24) provides many more connection sites for its multiple accessories. The geometry has understood locations for side, rear, and interior components. Accessories not only provide extended range, but also improved performance, greater storage options, and recreational enhancements (see Figure 25).

Similar to the *Helmet* platform, the *SaddleBag* is powered by a singular motor located at its rear. The batteries are also located directly below the occupants. The *SaddleBag* however is unique by maximizing its translucency both for the interior and the powertrain, exhibiting its functionality.

Although the *SaddleBag* can be used without accessories, it does depend on these components for extended functionality. Therefore, much thought must be given to accessory management. This vehicle depends on a heavy infrastructure for dressing, undressing, storage, and maintenance of accessories.

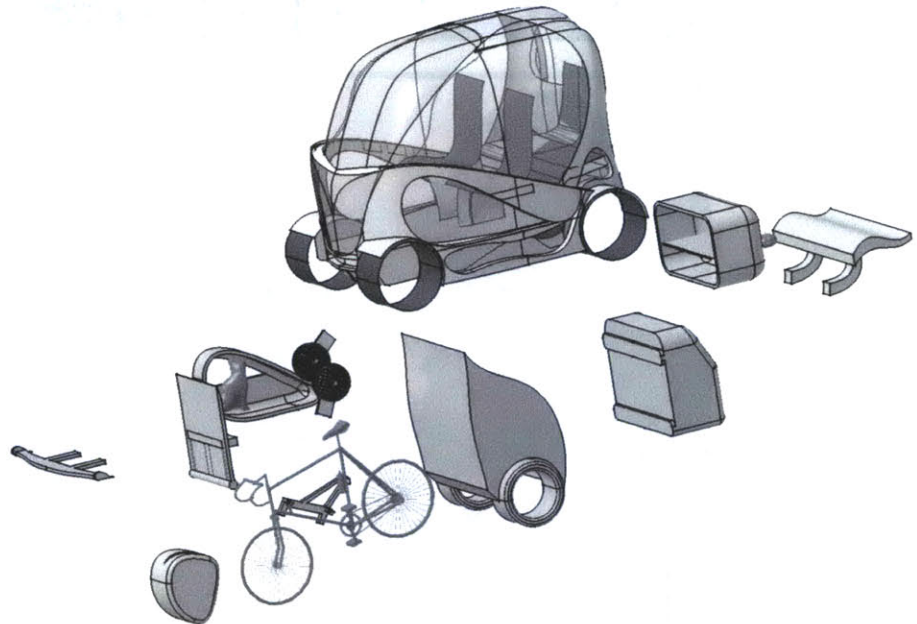

Figure 25: SaddleBag accessories

5. Backpacker Evaluations and Evolution

Initial designs such as the *Two-4-Cube* looked at occupying the most minimal footprint while still providing the versatility to transform from a two passenger commuter to a short term four passenger vehicle. The *Helmet* and the *SaddleBag* looked at stripping the vehicle down to its bare essentials – a street safe golf cart, while preserving a platform that encouraged accessorizing. Why lug around excessive storage, seating and accessories, when they are only used a small percentage commuting? Each of these vehicles provided snap-on areas to improve the car's range, storage, and recreational capabilities, but only when needed.

The following chart allows comparison of each vehicle's estimated specifications. Dimensions and vehicular weights are derived from CAD built models.

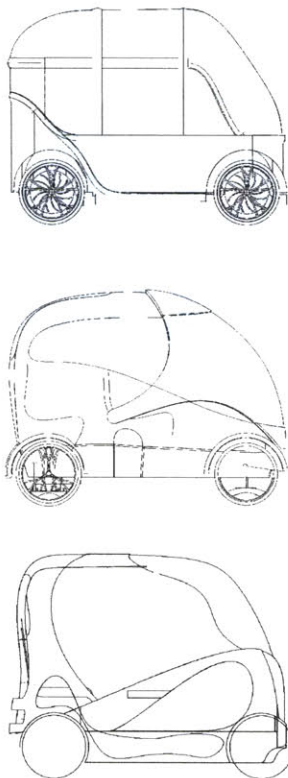

Figure 27:
Backpackers'
profile

Car type	<i>Two-4-Cube</i>	<i>Helmet</i>	<i>SaddleBag</i>
Length	102.3 in.	105.7 in.	93.5 in.
Width	72.9 in.	68.9 in.	65.3 in.
Weight*	1950 lbs	1807 lbs	2120 lbs
Range**	160 miles	180 miles	140 miles
Recharge time**	80% 40 min, full 60 min	80% 40 min, full 60 min	80% 40 min, full 60 min
Battery type	Li-Ion 18650	Li-Ion 18650	Li-Ion 18650
Drivetrain	Single motor rear wheel drive	Single motor rear wheel drive	Single motor rear wheel drive
Chassis	Steel tubular cage	Layered steel shell	Steel safety cage

* Weight derived from digital model with material assignments

** range and recharge time for lithium ion batteries based on power formulas from T-Zero® electric vehicle that utilizes 18650 batteries.

Chart 2: Specifications for various *Backpacker* models

Although the *Backpacker* system may offer great potential to serve urban environments, it requires significant infrastructural dispensers to house accessories and fully service the vehicles. For such a shared vehicle system to be successful, we must instead look at repackaging more functionality into the individual vehicle while still offering a relatively efficient option.

III City-Car

City-Car – a convenient, efficient, and chic addition to public and private transportation in the city. The City-Car is an adaptive vehicle that provides a fun driving experience in dense areas and occupies the smallest possible footprint when parked. The cars share a platform that can be accessed on demand for charging, networking, and cleaning to accommodate the way people live today. Together the vehicle and system embody an exciting vision of urban mobility.

1. Characteristics

Similar to the Backpacker, the City-Car also attempts to minimize excessive use of resources. However, vehicles in this system contain more functionality to provide greater convenience to the user. The integrated functionality also alleviates the system from complex infrastructural needs. The City-Car embodies five main characteristics.

1.1 Convenient

Above all City-Car needs to be convenient and easy-to-use by addressing unmet market needs in dense urban areas in the United States and abroad as well. Congestion on roads and lack of parking can make driving a private passenger vehicle impractical or impossible. This car will serve city residents who do not own a car or need a complementary vehicle for trips within a 100-mile radius. It may also be ideally suited for fleet owners who could benefit greatly from a shared platform.

1.2 Urban

City-Car must complement existing transportation modes and blend into the urban landscape as it moves through the city's densest neighborhoods. A "good neighbor", City-Car must creatively save space, materials and energy. First by implementing a shared platform, resources of material and space can be efficiently allocated to many users. Also, alternative energy platforms to tackle environmental implications must be considered in densely populated urban areas.

1.3 Networked

The vehicles need to be both digitally and physically networked to provide numerous benefits of a shared platform. Digitally this network provides a smaller community within a broader urban context. The cars can be intelligently networked to facilitate communication among members of the community quickly and efficiently. Physically the cars will linearly plug into each other, in the same nature as shopping carts, for charging, storage and cleaning. As the network grows the shared platform will offer more and more benefits for participants and the city.

1.4 Chic

City-Car should enhance each owner's identity by being personalizable and chic. The car should know its driver and allow for personal expression through exterior color alterations and interior re-configurability for unique ergonomics, display and driving characteristics.

1.5 Adaptive

The most encompassing characteristic of City-Car must be its adaptive nature. The vehicle needs to accommodate to tight parking spaces, dense urban roads, and wide intra-city connectors, such as local highways. The same feature can allow each user to customize his or her driving experience. For example, multiple heights will allow the car to sit comfortable among large vehicles. Options such as an articulating chassis may allow the vehicle to be truly adaptive to road conditions, driving dynamics and evolving urban environments.

To fulfill these five characteristics, the vehicle platform and the system in which it exists must be developed. The vehicle platform is designed digitally through CAD resources, mainly Catia®, to develop blueprints for future concept vehicle fabrication. Complementing to the vehicle's system, urban analyses evaluate the impact that the City-Car may have upon vehicle ownership, resource usage, and urban planning.

2. Design Iterations

2.1 Shopping-cart-car



Figure 28: *Shopping-Cart-Car*

This vehicle is the first version of the City-Cars to address urban density by reconfiguring its form. This model illustrates how the skeleton of the vehicle transforms to accommodate another vehicle into its void space (see Figure 28). Unfortunately, folding the car in such a manner results in many mechanical complications. The vehicle gains significant weight from multiple joints and actuators. More important, the structural integrity of the vehicle is compromised by having so many movable parts. These moving components become weak points in the case of an impact.

2.2 LoxBox

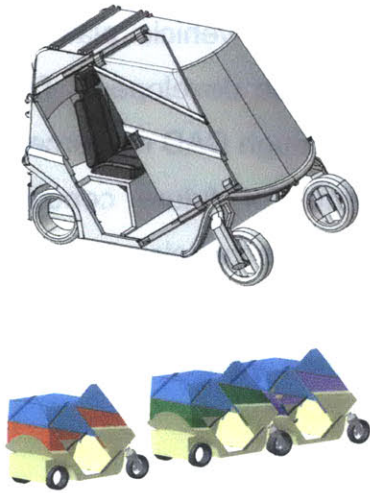

Figure 29: LoxBox

The *LoxBox* (see Figure 29) proposes a linear parking system as the *Shopping-cart-car* yet without the extreme folding. Eliminating transformation preserves the structural integrity of the cabin and allows the vehicle to remain relatively lighter. The exterior geometry has a distinctive front form which is translated again to the vehicle's rear allowing them to link together. When joined, the multiple cars are serviced in series, cleaned and charged.

The *LoxBox* has a unique ingress component, a diagonal sliding door. The slanted rectangular entrance is largely influenced by the profile of the seated occupants (see Figure 30). No longer do the occupants have to awkwardly lower themselves into the vehicle, instead they are able to transverse directly sideways onto their seats.

Aside from the *LoxBox*'s distinctive ingress/egress sliding door, it also has unique driving characteristics. The pivot arms on the front wheels behave as casters, allows for an extremely tight turning radius. The vehicle is powered by an electric powertrain with two electric motors located at the vehicle's rear. The decoupled rear-wheel drive combined with free-spinning front wheels allows for enhanced mobility.

Giving the *LoxBox* character, its box-like geometry is also a functional display surface that allows the user to externally express their personality or even advertise. When parked in a larger stack the walls unite to create an even larger synchronized display. Aside from advertising and networked daily updates, the uniform display may be used to enhance its urban surroundings.

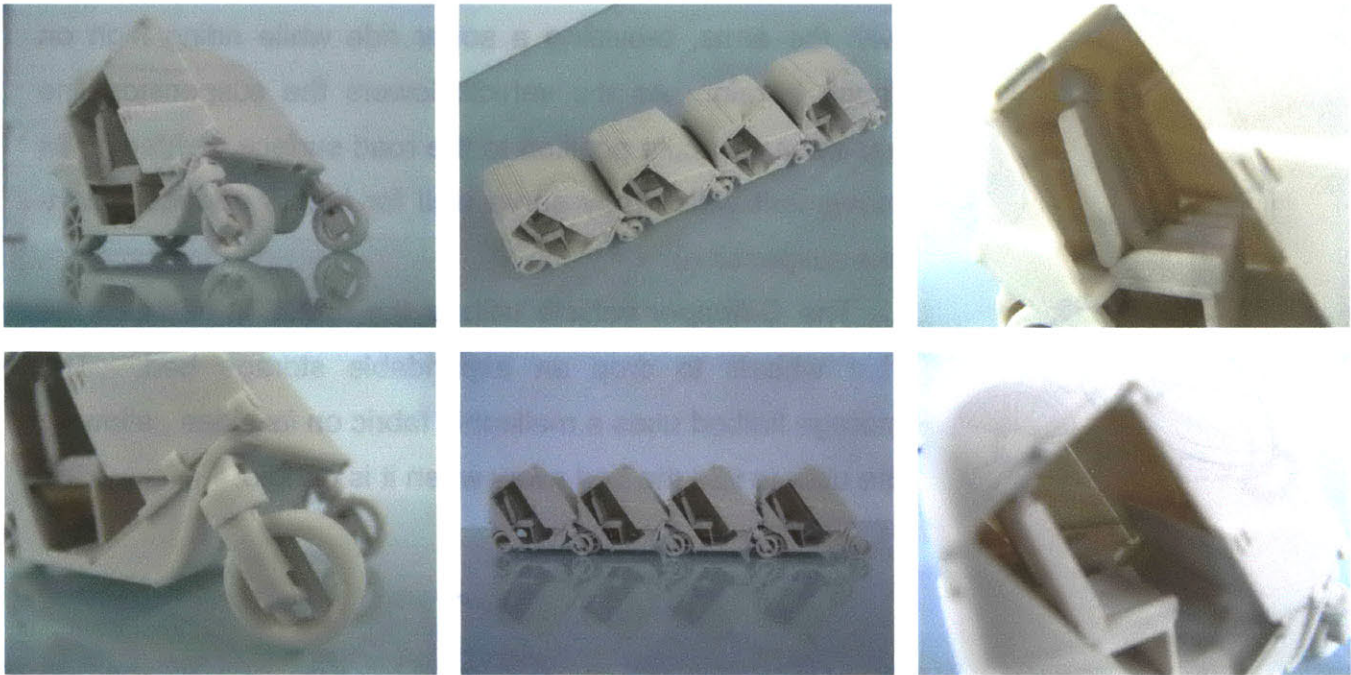
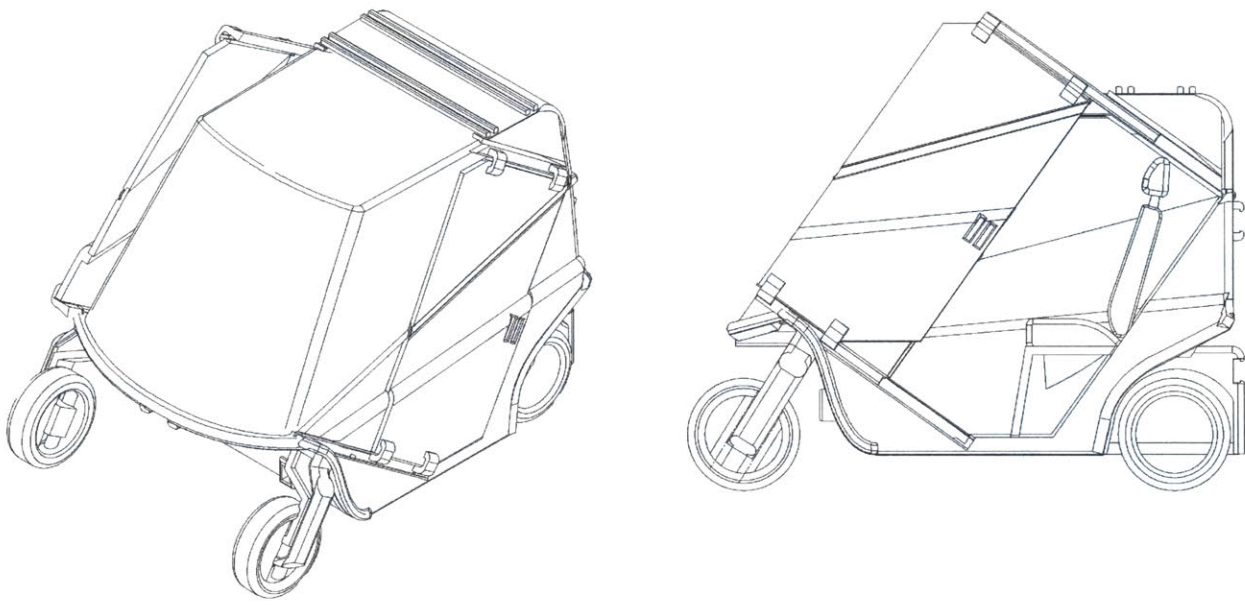

Figure 30: *LoxBox* blueprints & 3-D printed studies

2.3 G-hopper

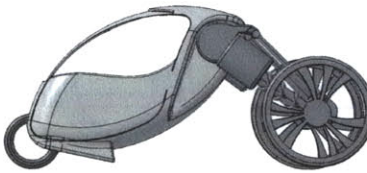
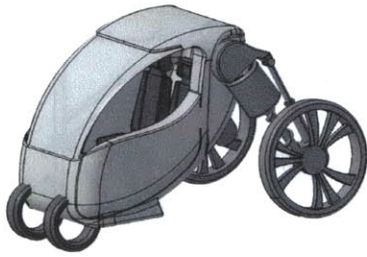
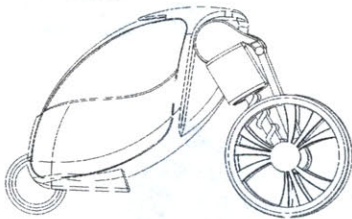
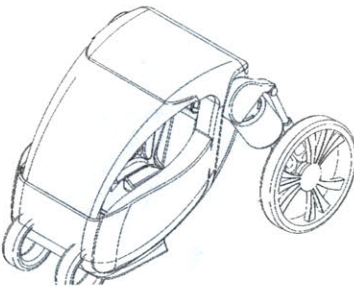

Figure 31: *G-hopper*



The *G-hopper*, named for its insect-like head and large rear legs, transforms its wheel location to reposition its body (see Figure 31). This articulation not only provides tight parking but also adapts to multiple driving dynamics. The *G-hopper* can maintain an upright driving position for enhanced visibility driving in congested urban conditions. As vehicle speed increases, the wheeled arm extends back to enlarge its driving footprint and improve driving stability (see Figure 32). Two independent motors are located at the shoulders of the vehicle to lift and lower the body.

The suspension components of the *G-hopper* are in-line with the arms, providing a softer ride while riding high on rough terrain. As the vehicle lowers the suspension line assumes an acute position to the road surface, tightening its movement which may serve well for higher speeds (sport-like suspension).

The *G-hopper* vehicle utilizes the space in-between the rear wheels to drop an expandable storage bed. The storage flatbed uses a malleable fabric on its sides, allowing the user to fold the bed away when it is parked.

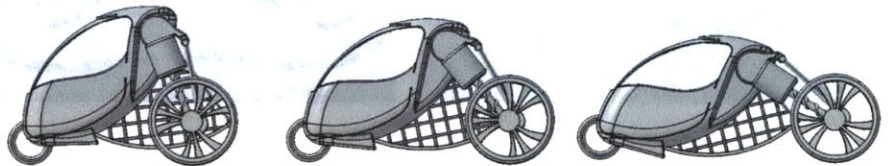

Figure 32: *G-hopper* repositioning rear drivetrain for multiple driving positions

The rear wheels are located wider than the vehicle sides giving a stable wheelbase and allocating a space for subsequent vehicle to park behind (see Figure 33).

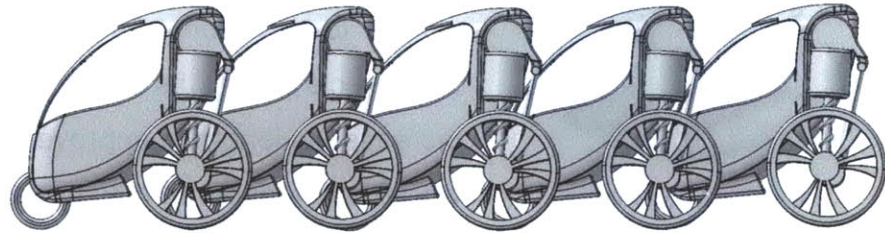

Figure 33: *G-hoppers* linearly nested for tight parking

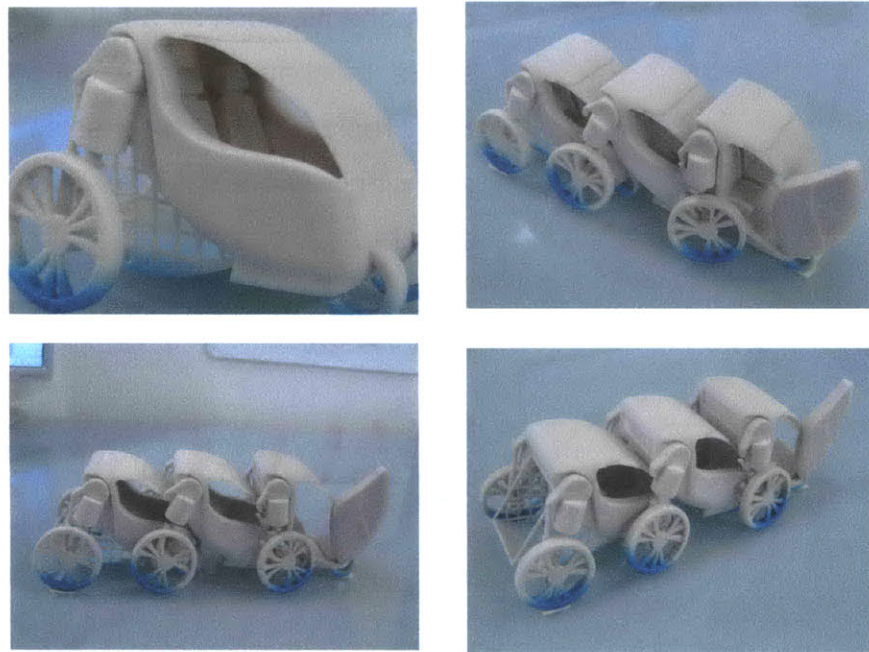

Figure 34: *G-hoppers* 3-D printed models

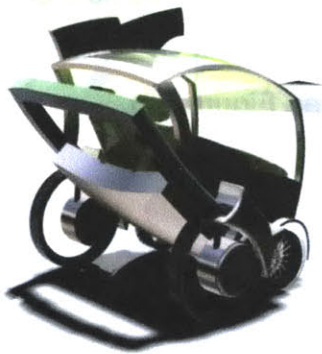

Figure 35: *B-Carr*

2.4 *B-Carr*

Similar to the *G-hopper* the *B-Carr* repositions its body by moving two independent rear powertrains (see Figure 35). Instead of a pivot arm, two parallel rails are used for the rear wheels to travel on. As the wheels travel back on the rail, the vehicle lowers its center of mass and the wheelbase is increased in length to improve its driving dynamics. The rear wheels act independently for unique driving behavior.



Figure 36: Modular illustration of *B-Carr*

The *B-Carr* has a modular architecture to promote ease of maintenance (see Figure 36). Since fleets of these vehicles will need servicing from time to time, the *B-Carr*'s modular assembly may allow the replacement of full components, such as a full powertrain wheel, by unlocking a single mechanical and electronic component. Simplifying this replacement mechanism for maintenance allows servicing without completely removing the vehicle from the system.



Figure 37: *B-Carr* Stacked at dispenser

When parking in the stack, the *B-Carr* is able to reduce its net length by 46 percent (see Figure 38).



Figure 38: Profile view of stacked *B-Carrs*

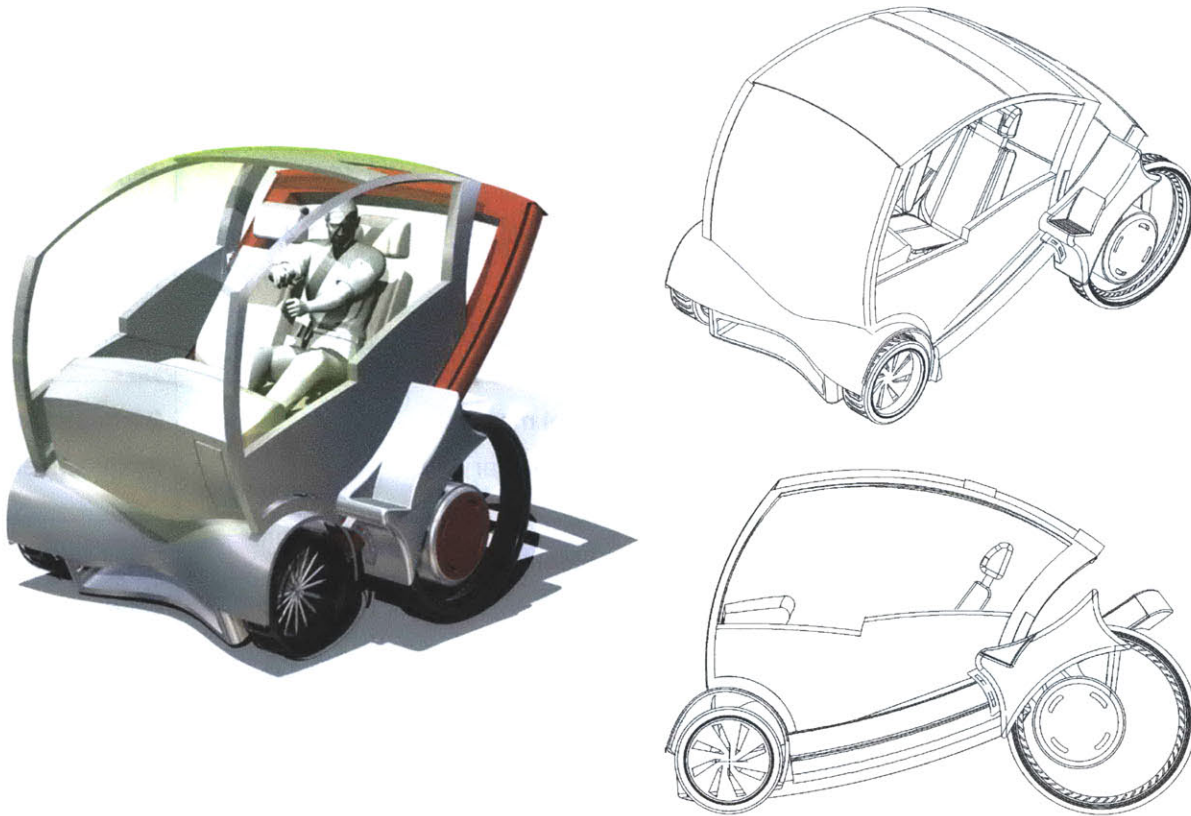
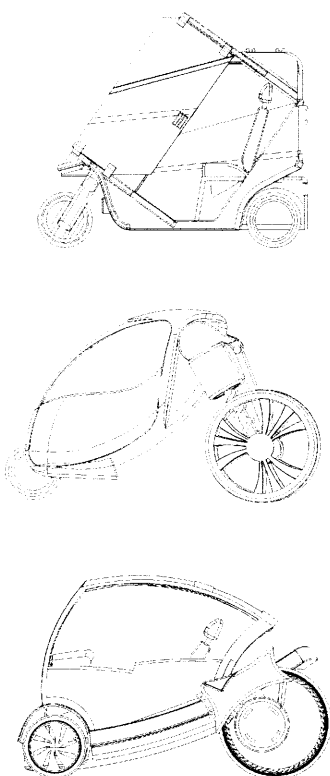

Figure 39: Multiple views of *B-Carr*

3. Analysis of Design Iterations

The City-Car has gone through numerous evolutions. Although its objective has remained the same – provide transportation with the most efficient use of resources, the way the designs have approached this goal have each been unique.

Specifications of each vehicle are compiled from their respective digital model.



Car type	<i>LoxBox</i>	<i>G-hopper</i>	<i>B-Carr</i>
Length	100 in.	134.6 in.	109.5 in.
Folded length	N/A	107.5 in	65 in
Stacked length	79.5	72 in	59.4 in
Width	73.2 in.	84 in.	68 in.
Weight*	2040 lbs	2200 lbs	2300 lbs
Range**	250 miles	190 miles	160 miles
Recharge time**	80% 40 min, full 60 min	80% 40 min, full 60 min	80% 40 min, full 60 min
Battery type	Li-Ion 18650	Li-Ion 18650	Li-Ion 18650
Drivetrain	Dual motor, 2-wheel rear drive	2 independent motor-wheels	2 independent motor-wheels
Chassis	Steel tubular cage	Steel uni-body w/ roll-cage	Steel safety cage

* Weight derived from digital model with material assignments

** range and recharge time for lithium ion batteries based on power formulas from T-Zero® electric vehicle that utilizes 18650 batteries.

Chart 3: Specifications of various City-Car models

The *shopping cart* vehicle was the most “tongue-and-cheek” design study; nevertheless, its purpose was to analyze exactly how close the vehicles could be packed by

exploiting the unused interior space while parked. Complications such as cumbersome mechanical actuators and joints stifled such radical vehicle architecture, yet much was learned from the studies which lead to further development of linearly parked vehicles like the *LoxBox*.

Though the *LoxBox* cars do not transform, geometrically they lock into each other for compact linear parking, charging, and servicing. Still the problem of making such a small vehicle appealing remains prevalent. Small vehicles are great in dense urban areas when congestion is problematic. However, the vehicle must be versatile enough to handle both slower urban traffic and hostile driving environments such as the highway. A driver does look *smart* navigating through Paris with a Smartfortwo® because it is built to handle such an environment. However, once the same extremely small vehicle is used on a spacious highway, the same of that driver cannot be said. It soon became apparent that the *City-Car* must be able to adapt – it must be able to navigate and reside in small dense urban environments, yet still flourish in diverse driving conditions adjacent to the urban core. Thus this reasoning caused the introduction of articulating and transforming vehicles. How to approach this transformation mechanically and efficiently now becomes the new problem. The *G-hopper* and *B-Carr* each address this feature in unique ways.

The *G-hopper* introduces a pivot arm to tuck the rear wheels tightly behind. Although the pivot joint is simple and robust, the mechanical advantage is compromised at its lowered position.

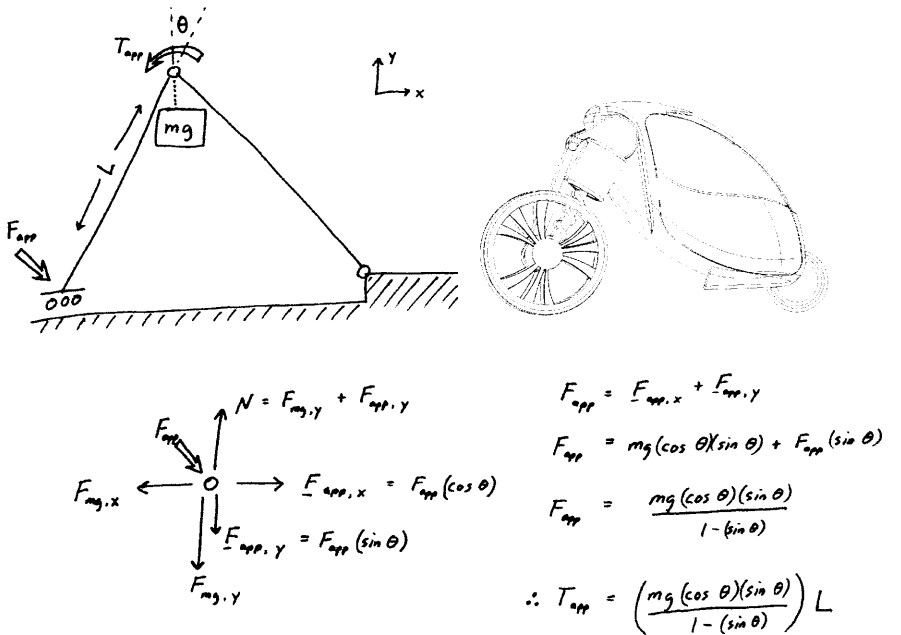

Figure 40: Free-body-diagram of G-hopper actuator

As seen by the free body diagram, a significant amount of torque is needed to lift a massive weight (up to 1500 lbs).

The *B-Carr* addresses this problem by instead wedging the articulating powertrain upon a rail. Along with frictional forces to overcome, the rear powertrain components must pivot the weight of the vehicle upwards.

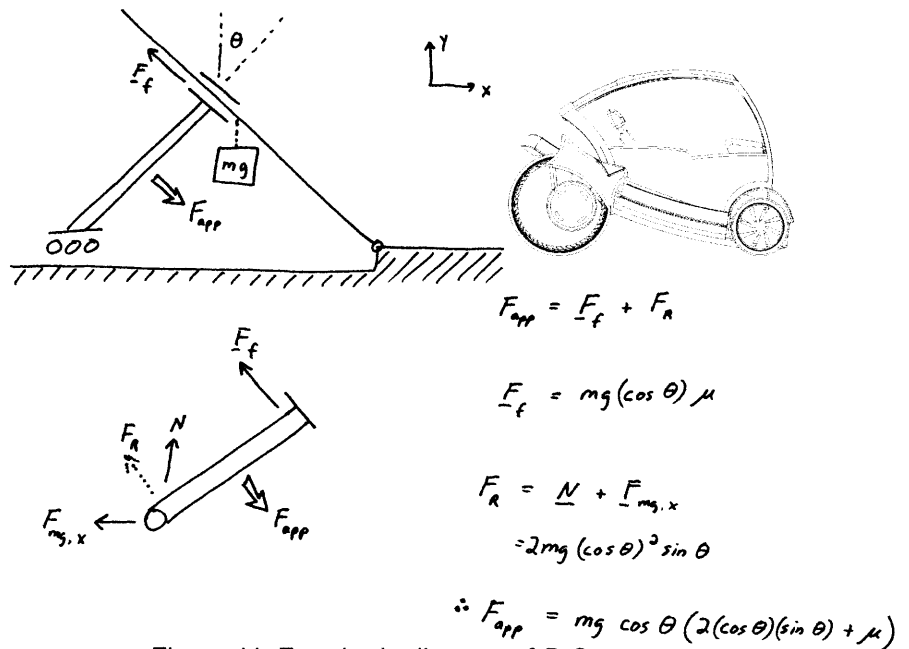
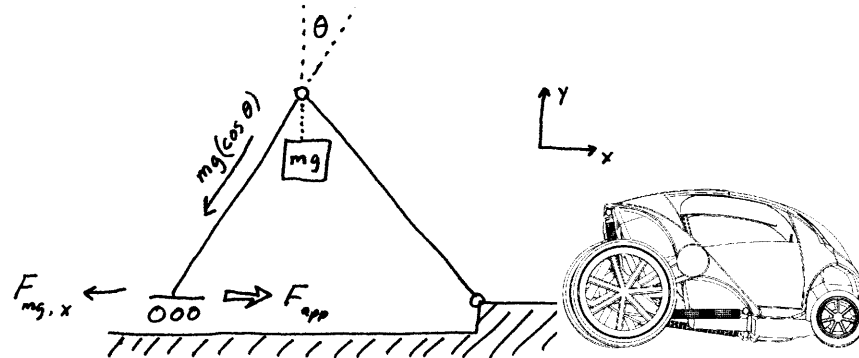

Figure 41: Free-body-diagram of B-Carr actuator

Although forces required to reposition the vehicle in this fashion are significantly lower, there are mechanical complications using a slide rail. Keeping the slide sealed from external elements such as road debris complicate the design. Also, well engineered robust slide components have proven to be expensive and require relatively more maintenance to keep its guides clean and lubricated. Therefore focus can be placed back upon the simplicity of a pivot joint.

Instead the design must rethink the arm actuation. Applying a force at the extent of the lever arm provides a significant mechanical advantage instead of attempting the turn the arm at its joint, as in the “G-hopper.” This feature is explored in the final design.



$$F_{mg,x} = -mg (\cos \theta)(\sin \theta)$$

$$\therefore F_{app} = mg (\cos \theta)(\sin \theta)$$

Figure 42: Free-body-diagram of newly proposed actuator

Taking the formulas found from the three free-body-diagrams, the necessary applied force (F_{app}) can be compared.

Pivot motor (<i>Chicken</i>)								
Vehicle mass - m (kg)	450.0	450.0	450.0	450.0	450.0	450.0	450.0	450.0
Vehicle position - Θ (deg)	0.0	10.0	20.0	30.0	40.0	50.0	60.0	70.0
Pivot Actuator force - F_{app} (N)	0.0	912.6	2154.1	3819.2	6079.0	9281.7	14253.3	23502.0

Linear slide (<i>Slider</i>)								
Vehicle mass - m (kg)	450.0	450.0	450.0	450.0	450.0	450.0	450.0	450.0
coefficient of friction - μ	0.02	0.02	0.02	0.02	0.02	0.02	0.02	0.02
Vehicle position - Θ (deg)	0.0	10.0	20.0	30.0	40.0	50.0	60.0	70.0
Linear Actuator force - F_{app} (N)	176.4	1659.1	2829.5	3460.3	3462.1	2905.0	1997.8	1029.9

Linear actuator w/ pivot (<i>Flex</i>)								
Vehicle mass - m (kg)	450.0	450.0	450.0	450.0	450.0	450.0	450.0	450.0
Vehicle position - Θ (deg)	0.0	10.0	20.0	30.0	40.0	50.0	60.0	70.0
Linear w/ pivot - F_{app} (N)	0.0	754.2	1417.3	1909.6	2171.5	2171.5	1909.6	1417.3

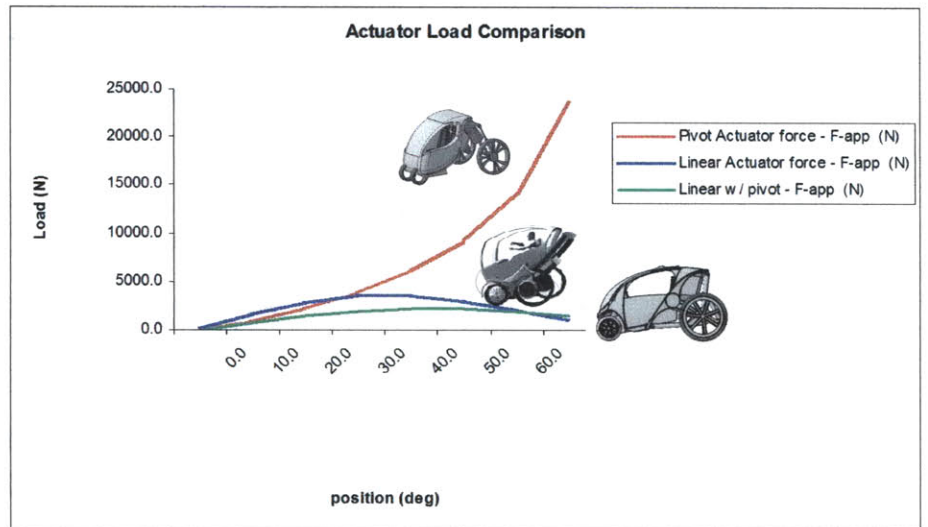

Chart 4: Analysis of various actuators used to reposition vehicles

Comparing the calculated forces necessary to lift the vehicles at various angles, it becomes quickly apparent how much less energy is required using the slide mechanism and pivot with a linear actuator compared to only an isolated motor at the pivot joint.

4. Final Design

The final vehicle design encompasses key features from the previous design iterations. As all the City-Cars, it is an electric powered motor driven platform and sustains a small footprint while parked. It articulates by taking advantage of a simple pivoting arm actuated by fluidic Festo® muscles, giving the vehicle the name *Flex*.

The Flex City-Car is designed to be a small shared vehicle that takes advantage of two independent arms that reposition the motor-powered wheels. The arms pivot around these joints for two purposes – compact parking and multiple driving dynamics.

The compact parking is achieved when the wheels tuck fully underneath its chassis to reduce the footprint of 127 inches to 96, a 25 percent reduction. The space saving impact becomes even greater when multiple vehicles park by stacking behind each other (see Figure 45). With the wider rear wheelbase, the nose of the following vehicle can nest behind to reduce the net individual footprint to now 71 inches, a significant 44 percent reduction.

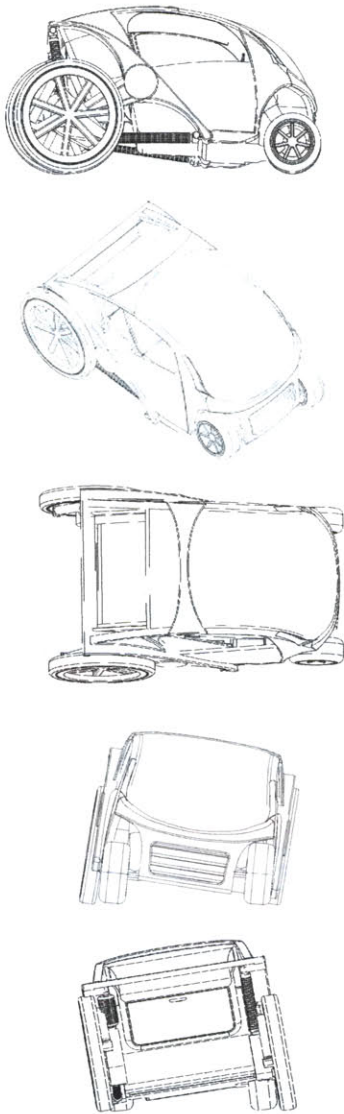

Figure 43: *Flex* City-Car blueprints



Figure 44: Stacked *Flex* City-Cars

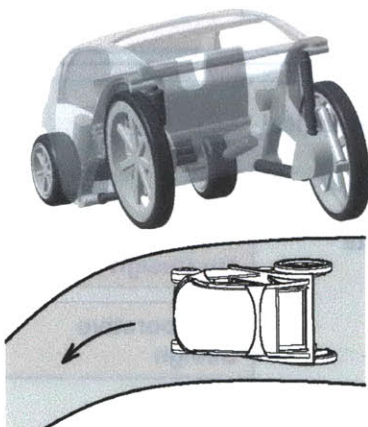

Figure 45: *Flex* car banking through turn

Unique driving dynamics may be achieved by actively repositioning the rear arms, allowing the vehicle to bank into turns and drive at multiple heights. Banking into a turn is achieved by accelerating the outer rear wheel and tucking it tighter to the body. This motion results in rotating the vehicle body into the turn, permitting it to better negotiate a tight turn.

4.1 Vehicle Components

The following diagram outlines the solution space for the components of the Flex City-Car (see Figure 46). The safety cage encompasses a dynamic seating cabin for front impact safety, and mechanical connection sites for the front and rear wheel assemblies. The rear wheel assembly, which governs the vehicle's movement, includes the drivetrain and transforming arms. The passive front wheel assemblies and power supply units have also been specified to coordinate with the vehicle's architecture.

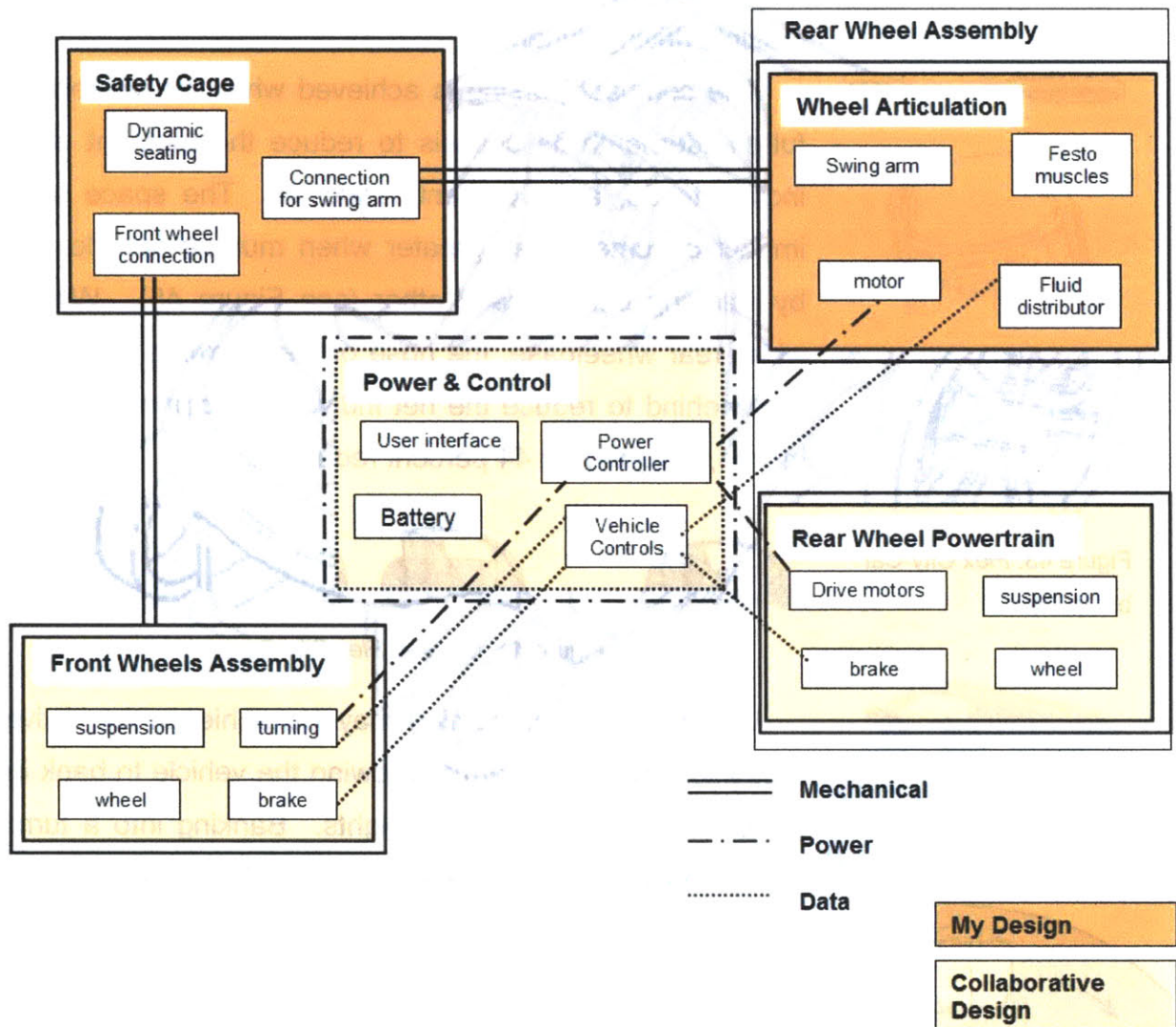

Figure 46: Flex City-Car solution space

4.1.1 Motor-Wheel Assembly

There are complementary projects within Smart Cities that support a number of the City-Car's vehicle designs, including the *Flex*. The "Hubless Wheel" is study that looks at redistributing the powertrain mechanisms by packaging individual motors and suspension components inside the hub of the wheel. Besides compact packaging, the Hubless Wheel frees up the vehicle platform to provide a modular architecture and significantly reduces un-sprung mass compared to traditional motored wheels. There have been numerous designs of the Hubless Wheel by Smart Cities students – Brian Chan, Patrik Künzler, Olumuyiwa Oni, Retro Poblano, and Peter Schmitt. The powertrains used in the *Flex* City-Car and previous models reflect evolutions of these wheel designs.

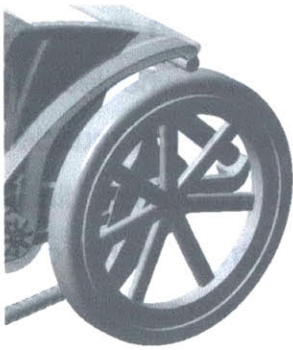

Figure 47: *Flex* car motor-wheel



Figure 49: Hubless Wheel prototype

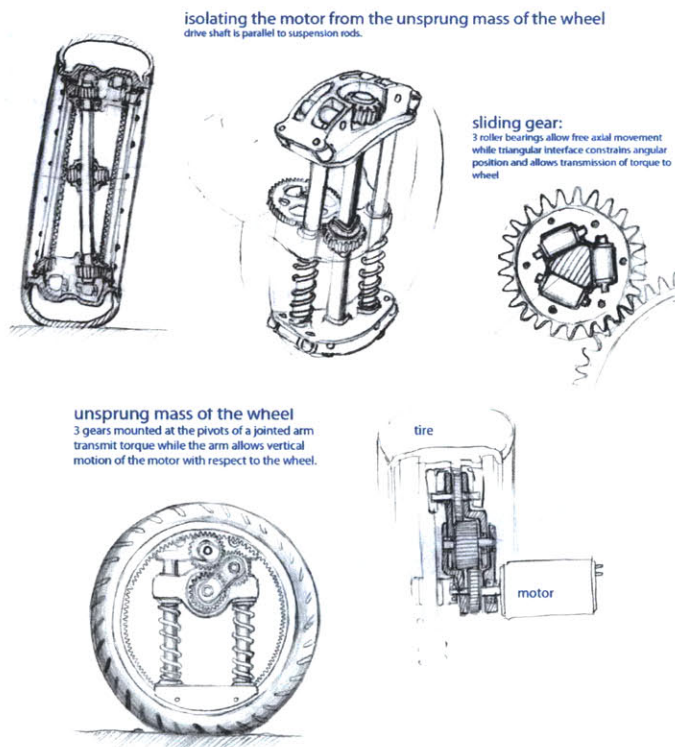

Figure 48: Hubless Wheel designs

4.1.2 Actuated Rear Drive

As other City-Car vehicles the *Flex* car can reposition itself by lifting up on its hind legs. Each motor-wheeled rear arm is positioned in place by two opposing Festo® muscles. Festo® fluidic muscle actuators are innovative linear pneumatics that utilize fibers in a lattice structure that once inflated behave like a human muscle by contracting. They are used in multiple scale operations, from small robotics to larger construction equipment. Triggering these linear actuators through the use of a gear pump may allow the *flex* car to reposition itself with significantly less effort than a single motor at the joint. A simple two-gear pump is used to redistribute the fluid between the two muscles (see Figure 51).

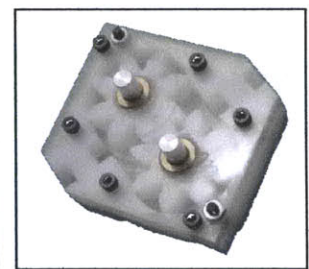
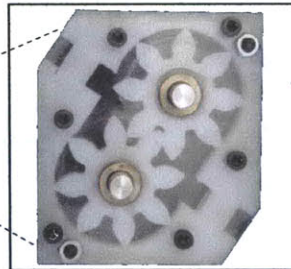
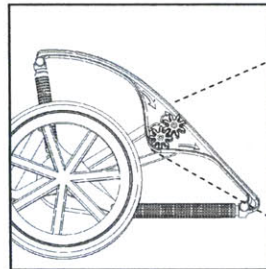
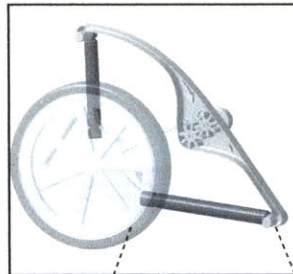
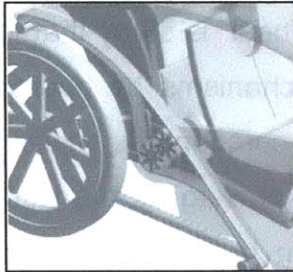

Figure 51: Fluid actuator and gear pump design



Figure 50: Festo® fluidic actuator

4.1.3 Chassis

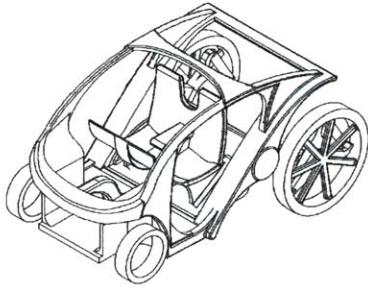
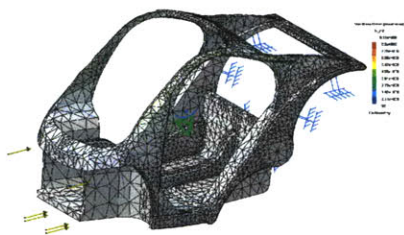

Figure 52: *Flex* chassis platform

The Chassis of the vehicle serves several roles. It must house and amalgamate all components (see Figure 52). It also plays a vital role in separating the interior from external elements. Yet most important, it must keep its occupant safe. Safety in a vehicle of such small size is always a valid concern. However, vehicles such as the Smartfortwo®, which are 40 percent shorter in length than average American sedans, have proven that a reinforced safety cage can be robust enough to maintain structural integrity, even when involved in a direct front impact at high speeds up to 70 miles per hour. A safety cage on the *Flex* car must be able to endure the same.

The *Flex* car addresses safety in two ways. First it has an extremely robust safety cage to reduce vehicle deformation. Second, the integration of an internal dynamic cabin assists in slowly decelerating the occupants.

4.1.3.1 Safety Cage



The *flex* car proposes a layered aluminum safety cage to minimize its deformation in high impact. Since a vehicle of such small size does not have much room for a crumple zone, the cage must be structurally reinforced to prohibit deformation allowing little to no impedance into the occupants' space.



Figure 53: Stress analysis on safety cage

Structural integrity analyses of the aluminum safety cage were done using Catia's physics analysis workbench – *Generative Part Structural Analysis*. The aluminum cage is induced to forces to simulate impact. These digital analyses revealed that the structure may maintain its general form under extreme measures (see Figure 53). When inducing

the structure to forces up to 35 kilo-Newtons the cage deformed only 225 mm (see Figure 54).

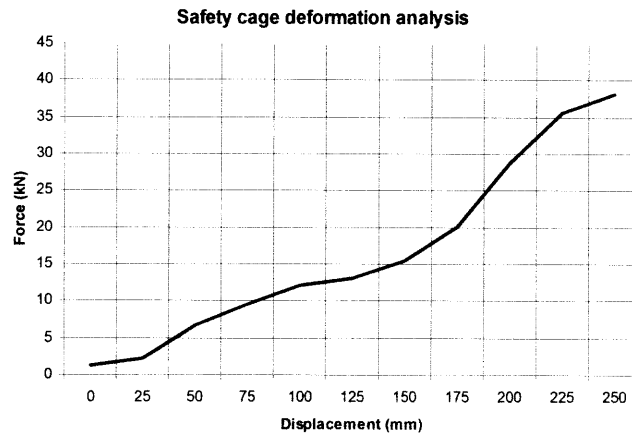

Figure 54: Force/Displacement study

Sacrificing the crumple zone however causes the occupant to decelerate more rapidly compared to collisions in longer vehicles. A crumple zone is typically necessary in high impact conditions to behave as a dampener, protecting the occupants by exposing them to a less drastic deceleration than that at the impact point. Although the safety cage can protect the occupants from intrusive deformation in massive collisions, this robustness is only well served if vehicle can accommodate biometric parameters – slow down gradual enough allowing the body to handle the resulting forces induced on it.

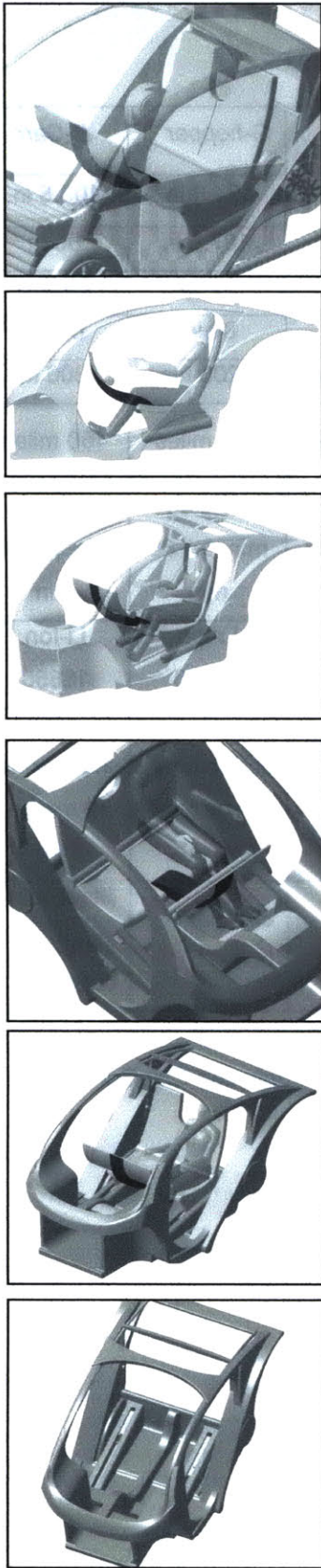

Figure 55: Dynamic Cabin renderings

4.1.3.2 Dynamic Cabin

To compensate the lack of a crumple zone, a dynamic interior has been incorporated to reduce the rate of deceleration separate than that of the car body by decoupling the caged chassis from the occupants' interior shell. Although the concept has recently been coined by Pininfarina's *Pido*® vehicle, there are fundamental differences between the designs. The *Pido*® encompasses the occupant in an internal sled that shifts directly forward in a front-impact crash. The *Flex City-Car* however holds the seating units on an internal curved rail system that will not only guide the deceleration of the occupants but also reposition their body more horizontally so that forces experience are distributed tangentially to the length of the body rather than perpendicularly, preventing the occupants' upper body from being violently jerked forward. The goal is to no longer depend on the external crumple zone for deceleration but to instead predetermine the crumple path and reposition the occupants allowing a lower deceleration curve than that of the external safety cage.

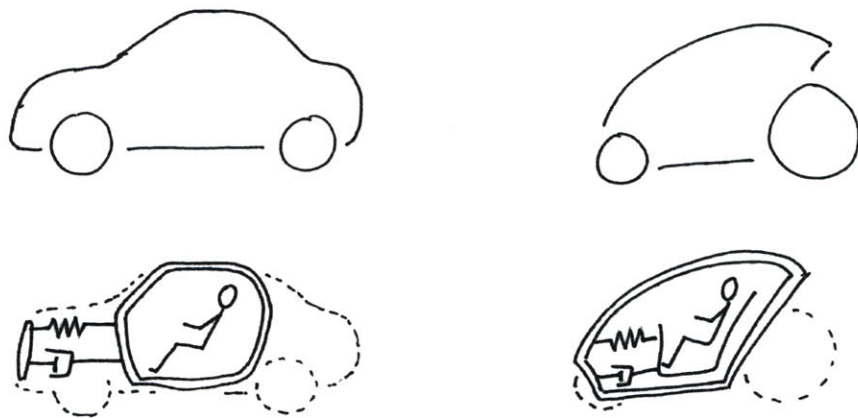
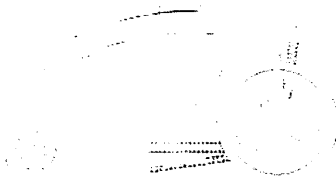
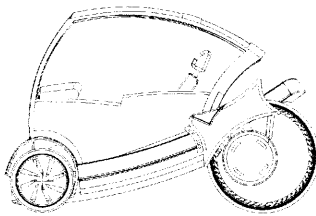
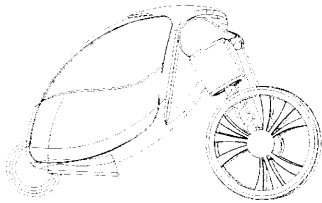
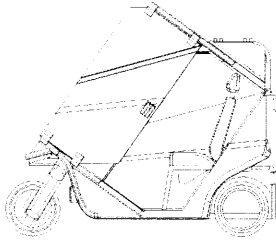

Figure 56: Diagrammatic image of dynamic cabin compared to standard vehicle

4.2 Specifications Comparison



Car type	Flex	LoxBox	G-hopper	B-Carr
Length	127.2 in.	100 in.	134.6 in.	109.5 in.
Folded Length	96 in.	N/A	107.5 in	65 in
Stacked length	70.4 in	79.5	72 in	59.4 in
Width	60 in.	73.2 in.	84 in.	68 in.
Weight	1850 lbs	2040 lbs	2200 lbs	2300 lbs
Range	80 – 100 miles	250 miles	190 miles	160 miles
Recharge time	80% 40 min*, full 60 min	80% 40 min, full 60 min	80% 40 min, full 60 min	80% 40 min, full 60 min
Battery type	Li-Ion 18650	Li-Ion 18650	Li-Ion 18650	Li-Ion 18650
Drivetrain	2 independent motor-wheels	Dual motor, 2-wheel rear drive	2 independent motor-wheels	2 independent motor-wheels
chassis	aluminum unibody	Steel tubular cage	Steel unibody	Steel safety cage

Chart 5: Specification comparison between City-Cars



Figure 57: Various versions of City-Car

5. System Analysis

Although much design focus is placed on the individual vehicle, for the City-Car to be successful it must cooperate and work efficiently in a community of City-Cars. Since the same vehicles are shared inside the city and in surrounding residential areas, traffic patterns must be studied to maintain the symbiotic relationship between both city and residential dispensers. Studying the traffic patterns is essential for two main reasons. First, the system must make sure that there are available vehicles for demand. Second, the number of City-Cars should be minimized to save resources of material and space.

Sine the City-Car system still dwells in its conceptual phase, empirical data cannot yet be studied. Exactly how users will adopt the system remains unknown. Understanding that the City-Car is catering to common urban commuters, we can however simulate traffic patterns that are relatively consistent with that of numerous centralized cities. Boston, New York, and Philadelphia may serve as good models. However, post-automobile developed cities such as Los Angeles, Detroit, and Houston will not be analyzed since the City-Car may not serve as a well suited transportation option to cover these vastly dispersed cities.

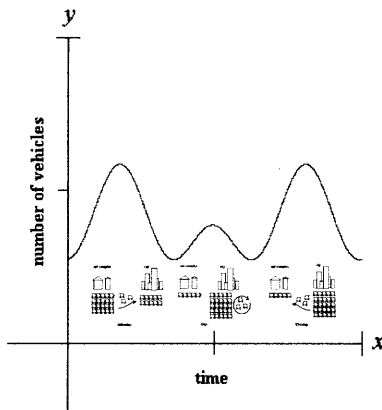

Figure 58: Typical traffic flow patterns

5.1 Traffic Patterns

The following graphs and calculations provide a platform to analyze daily traffic. Since the City-Car has not yet been directly linked with a specific city, we will generalize traffic patterns into measurable functions. Most graphs illustrate *volume of vehicles* (y) as a function of *time* (x). For initial analytical purposes these $y(x)$ functions are hypothetical traffic flow formulas that mirror typical urban patterns. Once a specific site has been established, any urban traffic flow functions can be plugged into the analysis to obtain its unique system characteristics.

The first graph illustrates traffic increasing at morning rush hour, slightly mid day, and again during evening rush hour. This sinusoidal pattern is fairly typical for any urban area – In the morning, thousands commute to jobs downtown, take care of small errands mid day, and return home in the evening. However, this graph gives us a macroscopic view of traffic; instead we need to analyze what local impact this has on City-Car dispensers in order to sustain available vehicles both inside and outside the urban core. Also the above graph symbolizes vehicles that are used in two-way travel. The City-Car instead offers one-way commute – users quickly rent a different vehicle each time they travel. Therefore, observing one-way rentals at individual stations will reveal different characteristics than that of the above typical traffic.

The following explains how each function varies for the city and the residential areas:

(Renting) - Out of residential dispenser "O-r"

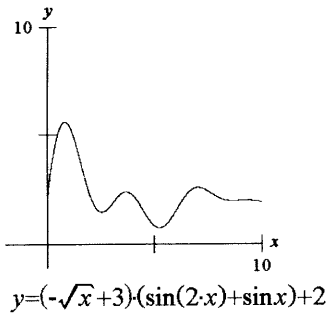

"y(x)" is the function of vehicles being taken from the residential dispenser ($y = \text{number of vehicles}$, $x = \text{time}$) located on the periphery. The first and largest peak represents the morning rush hour where vehicles are driven into the city by the common commuter. There is another increase during lunch break. The last peak reflects evening rush hour as different users that work outside the city leave from local businesses. Note the last rush hour peak is significantly lower than the first since many more residents work in the city versus the "reverse-commuters" that work at businesses outside the city center.

(Returning) - In to city dispenser "I-c"

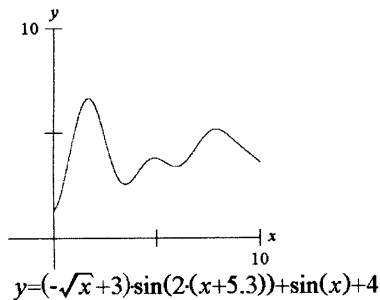

This graph illustrates vehicles being returned to the dispensers in the city. The function reflects similar properties as the previous graph of vehicles leaving their residence since many of the same vehicles leaving the home in the morning are parking in the city roughly 40 minutes later. The initial rush hour peak is also shifted later in time to reflect travel time.

(Renting) - Out of city dispenser "O-c"

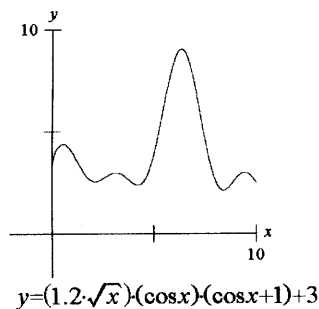

Properties of this function, vehicles being rented out of the city, practically mirror the previous two graphs. Fewer vehicles are used by "reverse-commuters" to travel outside the city during morning rush hour since less business is located outside of the city. Finally there is a spike in vehicle rental as majority of city workers travel back home.

(Returning) - In to residential dispenser "I-r"

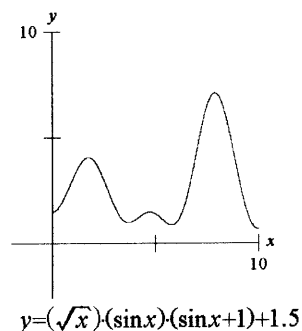

Finally the function of City-Cars being returned to the residential dispensers will reflect the previous (Out of city dispenser) with a time delay to take into account travel time.

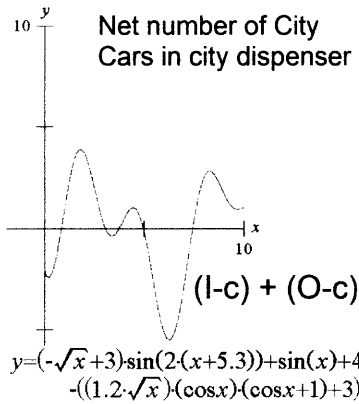

Combining functions - Because usage is increased during the rush hours (vehicles “out” of dispenser), the net of functions “I-c” and “O-c” results in a deficit of available vehicles at the dispenser. Therefore, to sustain the minimal amount of vehicles necessary, the graph must be shifted ($y \geq 0$). This shift represents an upward scaling of the entire City-Car system.

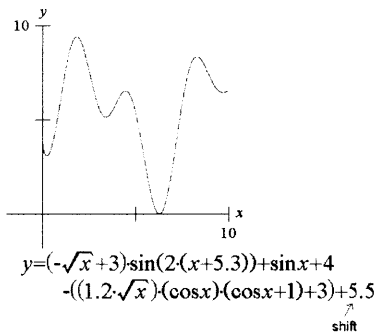

Shift: the absolute minimal point (critical point with lowest “y” value) for the function must be found by first setting the derivative to zero. Once the “y” value for the absolute minimum is found, it is added back to the original function to eliminate any negative value. In the graphs to the right, $y \geq 0$ is satisfied.

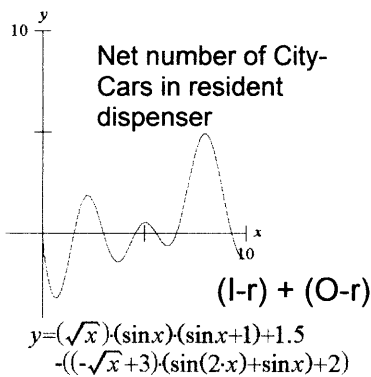

$y < 0, y > 0$

“y” represents the number of vehicles in the dispenser. During evening rush hour the demand for vehicles highly exceeds the availability.

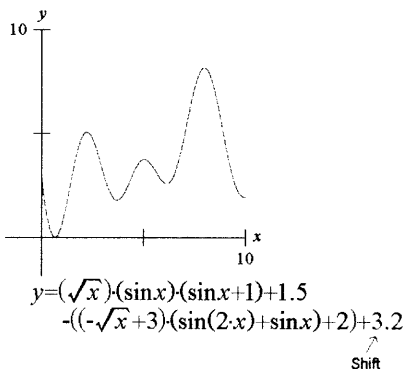

$y \geq 0$

In this case the demand for vehicles does not exceed the availability.

With the previous functions we can now find the **Average rental rate** over a day by calculating the integral of the function (*cars x time*) divided by $\text{time}^2 \dots (\text{cars}/\text{time})$

	In	Out	Net Rate
residence	$\frac{\int f_{I-r}(t)dt}{t^2}$ $y = (\sqrt{x})(\sin(x)(\sin(x)+1)) + 1.5$	$\frac{\int f_{O-r}(t)dt}{t^2}$ $y = (-\sqrt{x} + 3)(\sin(2x) + \sin(x)) + 2$	$\frac{\int f_{I-r}(t)dt - \int f_{O-r}(t)dt}{t^2}$ $y = (\sqrt{x})(\sin(x)(\sin(x)+1)) + 1.5 - (-\sqrt{x} + 3)(\sin(2x) + \sin(x)) + 2 - 3.2$
city	$\frac{\int f_{I-c}(t)dt}{t^2}$ $y = (-\sqrt{x} + 3)\sin(2(x+5.3)) + \sin(x) + 4$	$-\frac{\int f_{O-c}(t)dt}{t^2}$ $y = (1.2\sqrt{x})(\cos(x)(\cos(x)+1)) + 3$	$\frac{\int f_{I-c}(t)dt - \int f_{O-c}(t)dt}{t^2}$ $y = (-\sqrt{x} + 3)\sin(2(x+5.3)) + \sin(x) + 4 - (1.2\sqrt{x})(\cos(x)(\cos(x)+1)) + 3 - 5.5$

Since, the rental rate varies drastically throughout the day, it is necessary to analyze rental rates during specific times of the day to allow adjustments to the system. We need to now define the integral over a defined time (a to b).

Rental rate over definite time

	In	Out	Net Rate
residence	$\frac{\int_a^b f_{I-r}(t)dt}{(b-a)^2}$ $y = (\sqrt{x})(\sin(x)(\sin(x)+1)) + 1.5$	$-\frac{\int_a^b f_{O-r}(t)dt}{(b-a)^2}$ $y = (-\sqrt{x} + 3)(\sin(2x) + \sin(x)) + 2$	$\frac{\int_a^b f_{I-r}(t)dt - \int_a^b f_{O-r}(t)dt}{(b-a)^2}$ $y = (\sqrt{x})(\sin(x)(\sin(x)+1)) + 1.5 - (-\sqrt{x} + 3)(\sin(2x) + \sin(x)) + 2 - 3.2$
city	$\frac{\int_a^b f_{I-c}(t)dt}{(b-a)^2}$ $y = (-\sqrt{x} + 3)\sin(2(x+5.3)) + \sin(x) + 4$	$-\frac{\int_a^b f_{O-c}(t)dt}{(b-a)^2}$ $y = (1.2\sqrt{x})(\cos(x)(\cos(x)+1)) + 3$	$\frac{\int_a^b f_{I-c}(t)dt - \int_a^b f_{O-c}(t)dt}{(b-a)^2}$ $y = (-\sqrt{x} + 3)\sin(2(x+5.3)) + \sin(x) + 4 - (1.2\sqrt{x})(\cos(x)(\cos(x)+1)) + 3 - 5.5$

5.2 Providing Vehicles for Peak Hours

Depending on the time of the day, rental rates at certain dispensers may rapidly increase, too fast to be replenished. These increases may be pinpointed by studying the rental functions, $y(x)$ illustrated below, so that one may adjust the number of vehicles at the dispenser during its peak hour.

Peak rental rate, R_p (cars/min)

charge time per car, t_c (min)

number of cars in dispenser at time "t," n_t (unit-less)

time in dispenser, t_d (min) = n/R_p

Full charge if $t_c = t_d$

$\therefore (R_p)(t_c) = n_t$

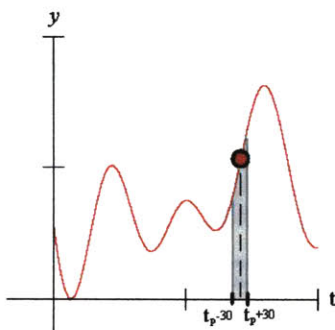
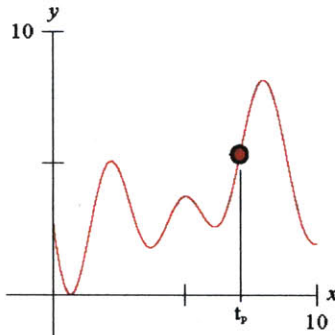
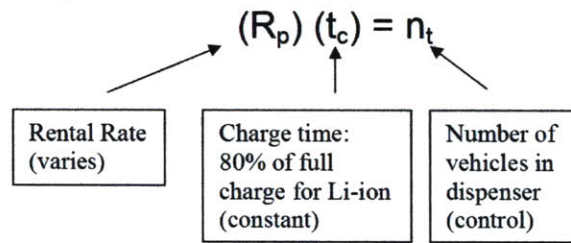

We will start with the net function of vehicles in the dispenser.

By setting the second derivative of the function to zero the inflection point can be found. The inflection point represents the largest slope, which correlates to the time where the rental rate peaks.

Solving the integral of the function 30 minutes before and after the time of the inflection point and dividing by the 60 minutes squared will reveal the peak rental rate during this hour.

We can now refine the formula to tell how many vehicles will be necessary during the hour where the rental rate is at its peak.

$$R_p = \frac{\left(\int_{t_p-30}^{t_p+30} f_d(t) dt \right)}{(60_{\text{min}})^2}$$

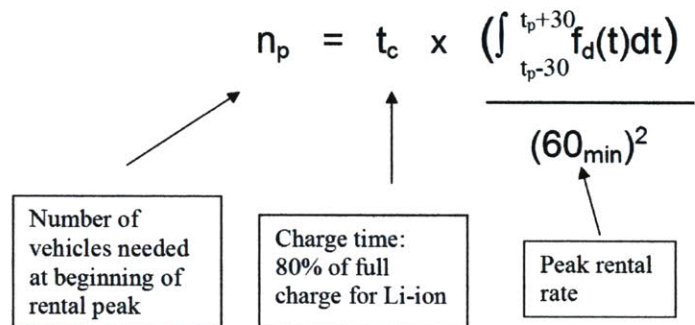

5.3 Cambridge Case Study

Cambridge, Massachusetts will serve as a brief case study to analyze the impact the City-Car system may have on urban environment. Over one-third (1491.37 acres) of Cambridge's landscape is dedicated solely to paved surfaces. A majority of these surfaces are used only to accommodate parked cars. Vast amounts of these cars remain idle for large parts of the day, using valuable landscape that could instead be served for other means.



Figure 59: Arial of Cambridge, MA

Basic urban data was first obtained to analyze the impact the system may have on parking (see Chart 6). Taking the dimensions of one single block (East Cambridge 550 by 200 ft) we may assume parallel parked vehicles will fit on the block's perimeter (East Cambridge – 1500 ft).

BASIC URBAN DATA		PAVED SURFACES	
		Total Paved Surface Area in Cambridge*	1,491.37 acres
		* from Cambridge 2004 paved surfaces study	
CITY BLOCKS		Cambridge	
<i>New York Block</i>		population	101600 people
Length (ft)	900	driving able	78060 people
Width (ft)	300	commuting population	53 900 people
Area (LxW, sq ft)	270,000	percent of single occupant commuters	35 %
<i>East Cambridge Block</i>		number of registered vehicles	56282 cars
Length (ft)	550	paved surface	1491 acres
Width (ft)	200		
Area (LxW, sq ft)	110,000		
<i>Boston (Back Bay) Block</i>			
Length (ft)	600		
Width (ft)	300		
Area (LxW, sq ft)	180,000		
		KEY	
		variables	
		constants	
		results	
* All parking space data for City of Cambridge. Jason Schriber, Transportation Planner.			

Chart 5: City data

CAR SPECIFICATIONS	Smartfortwo	LoxBox	G-hopper	B-Carr	Flex	05 Toyota Corolla
<i>Footprint (LxW above) sq.ft.</i>						
<i>Full length</i>						
Length ft	8.92	8.33	11.17	9.08	10.58	14.83
Width ft	5.75	6.08	7.00	5.67	5.00	5.58
Area sq ft	51.27	50.69	78.17	51.47	52.92	82.82
<i>Folded length</i>						
Length ft	N/A	N/A	8.92	5.42	8.00	N/A
Width ft	N/A	N/A	7.00	5.67	5.00	N/A
Area sq ft	N/A	N/A	62.42	30.69	40.00	N/A
<i>Net stack length</i>						
Length ft	N/A	6.58	6.00	4.92	5.83	N/A
Width ft	N/A	6.08	7.00	5.67	5.00	N/A
Area sq ft	N/A	40.05	42.00	27.86	29.17	N/A
<i>Footprint based on Tires</i>						

Chart 6: Car specifications

Dimensions of the various City-Car vehicles are input to compare their influence upon an urban system (see Chart 7). In addition, the Smartfortwo® and Toyota Corolla®, an extremely small vehicle and a reasonable size sedan, are also entered to the system to compare how much of an influence the individual vehicle design may have on the system.

	Smartfortwo	LoxBox	G-hopper	B-Carr	Flex	05 Toyota Corolla
Parking	Parallel Parkii Dispenser Stack					
Space btwn Cars (ft)	1.5	0	0	0	0	1.5
<i>Number of Cars</i>						
<i>New York block</i>						
Length	86.40	136.71	150.00	183.05	154.29	55.10
Width	28.80	45.57	50.00	61.02	51.43	18.37
<i>Cambridge block</i>						
Length	52.80	83.54	91.67	111.86	94.29	33.67
Width	19.20	30.38	33.33	40.68	34.29	12.24
<i>Boston block</i>						
Length	57.60	91.14	100.00	122.03	102.86	36.73
Width	28.80	46	50	61.02	51.43	18.37

Chart 7: Parking comparison

Each car's dimensions are input to the various city blocks to see absolutely how many vehicles may fit around the perimeter (see Chart 8 - The Flex car can fit 94 compactly stacked vehicle along one side of an East Cambridge block).

DISPENSER METABOLISM							
	time (hr)	Number of cars entering (cars)	Rate of car arrival (cars/hr)	Number of cars departing (cars)	Rate of car departure (cars/hr)	Curent number of cars in stack (cars)	Charging time provided / Time in stack (hrs)
Dispenser 1	0	0.49	1.23	1.20	1.15	5.00	4.36
starts with	2	1.96	2.25	1.09	1.29	6.92	5.38
5	4	2.53	1.90	1.48	1.61	6.15	3.82
cars in stack	6	1.26	1.23	1.74	1.38	4.10	2.97
	8	1.20	1.36	1.02	1.26	5.80	4.62
	10	1.52	1.44	1.49	1.77	1.68	0.95
	12	1.36	1.58	2.05	1.56	5.25	3.37
	14	1.79	1.93	1.06	1.22	14.90	12.21
	16	2.06	1.91	1.38	1.84	6.18	3.36
	18	1.76	1.60	2.30	1.75	2.29	1.31
	20	1.43	1.26	1.19	1.20	6.12	5.10
	22	1.08	0.54	1.21	0.60	3.64	6.04
							
Dispenser 2	0	0.30	0.45	0.40	0.75	4.00	5.33
starts with	2	0.61	0.70	1.10	0.77	3.85	4.97
4	4	0.79	0.57	0.45	0.41	4.67	11.48
cars in stack	6	0.36	0.29	0.36	0.41	3.31	8.16
	8	0.23	0.25	0.45	0.31	3.57	11.57
	10	0.28	0.24	0.17	0.24	4.02	16.72
	12	0.20	0.54	0.31	0.41	5.50	13.31
	14	0.88	1.14	0.52	0.47	13.44	28.57
	16	1.41	1.03	0.42	0.41	13.91	33.75
	18	0.65	0.40	0.40	0.39	4.04	10.25
	20	0.14	0.22	0.39	0.43	-0.09	-0.21
	22	0.30	0.15	0.46	0.23	2.20	9.47
							
Dispenser 3	0	0.90	0.69	0.09	0.48	3.00	6.28
starts with	2	0.48	0.59	0.86	1.47	1.22	0.83
3	4	0.69	1.04	2.08	1.49	1.18	0.79
cars in stack	6	1.38	1.09	0.90	0.82	4.59	5.56
	8	0.80	1.00	0.75	1.05	2.63	2.50
	10	1.21	1.53	1.35	1.20	6.30	5.26
	12	1.85	1.02	1.05	1.16	1.25	1.07
	14	0.18	0.08	1.27	1.46	-16.34	-11.21
	16	-0.03	0.81	1.64	1.50	-8.09	-5.39
	18	1.65	1.35	1.36	1.20	5.67	4.71
	20	1.05	0.98	1.04	0.83	5.97	7.19
	22	0.91	0.45	0.62	0.31	6.16	19.90
							

Chart 8: Dispenser metabolism

Next the theoretical traffic patterns are applied to understand the system's metabolism. By doing this, not only can we easily view the number of cars in a given stack at any particular hour, but we can also view the varying allotted charge time, current rental rate, and current return rate at each of the three stack dispensers.

Urban Implications		Maximum space needed to fit stack - length on block (ft)						
Maximum number of cars in stack during day								
Dispenser		Smartfortwo	LoxBox	G-hopper	B-Carr	Flex	05 Toyota Corolla	
1	14.90	155.20	98.09	89.39	73.25	86.91	243.35	
2	13.91	144.87	91.56	83.45	68.38	81.13	227.16	
3	6.30	65.67	41.50	37.82	31.00	36.77	102.97	
...square footage								
	892.39	596.69	625.76	415.10	434.66	1358.71		
	833.02	556.99	584.13	387.49	405.65	1268.32		
	377.59	252.47	264.77	175.64	183.87	574.90		
...surface area used from parking with 12 car system								
	2103.01	1406.15	1474.67	978.23	1024.07	3201.94		
number of cars in system		...total surface area used from all cars in system (w/ 1000 users)						
	10000.0	1752506.8	1171792.1	1228888.2	815195.0	853394.6	2668280.5	
	500.0	87625.3	58589.6	61444.4	40759.8	42669.7	133414.0	
	250.0	43812.7	29294.8	30722.2	20379.9	21334.9	66707.0	
	166.7	29208.4	19529.9	20481.5	13586.6	14223.2	44471.3	
	125.0	21906.3	14647.4	15361.1	10189.9	10667.4	33353.5	
	100.0	17525.1	11717.9	12288.9	8152.0	8533.9	26682.8	
	83.3	14604.2	9764.9	10240.7	6793.3	7111.6	22235.7	
	71.4	12517.9	8369.9	8777.8	5822.8	6095.7	19059.1	
	62.5	10953.2	7323.7	7680.6	5095.0	5333.7	16676.8	
	55.6	9736.1	6510.0	6827.2	4528.9	4741.1	14823.8	
	50.0	8762.5	5859.0	6144.4	4076.0	4267.0	13341.4	

Chart 9: Urban implications – surface area needed (per 1000 users)

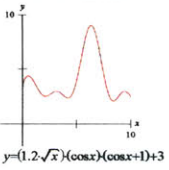
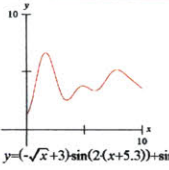
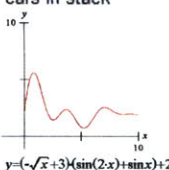
By merging data from the *system metabolism* and that of the parking we can determine what the minimum size of the stack must be to support peak influxes (see Chart 10 - Stack 1 – peak hour is 2pm when 14.9 vehicles are available). From this minimum stack size, the surface area required for dispenser placement is determined (Flex car - 1025.07 sq ft are needed to accommodate these ~15 vehicles). Subtracting the surface area required for each City-Car from the surface area required to accommodate standard vehicle constraints, the total amount of surface area saved by the three stacks can be compiled (Flex – with 100 City-Cars in the system, 10 users per City-Car, 8533.9 sq ft is needed).

cars per user	users	number of cars system supplements	space needed to park previously supplemented cars
0.01	1000.00	10.00	163.33
0.2	1000	200.00	3266.67
0.4	1000	400.00	6533.33
0.6	1000	600.00	9800.00
0.8	1000	800.00	13066.67
1	1000	1000.00	16333.33
1.2	1000	1200.00	19600.00
1.4	1000	1400.00	22866.67
1.6	1000	1600.00	26133.33
1.8	1000	1800.00	29400.00
2	1000	2000.00	32666.67

Smartfortwo	LoxBox	G-hopper	B-Carr	Flex	05 Toyota Corolla			
surface area recovered in parking								
-1751594.8	-1170880.1	-1227976.3	-814283.1	-852482.7	-2667368.5			
-86713.4	-40350.7	-43205.5	-22520.9	-41757.8	-115175.1			
-42900.7	7183.0	5755.6	16097.9	-20422.9	-30229.2			
-28296.5	35186.8	34235.2	41130.1	-13311.3	10245.3			
-20994.4	58308.2	57594.5	62765.6	-9755.5	39602.0			
-16613.1	79476.5	78905.6	83042.5	-7622.0	64511.6			
-13692.3	99668.4	99192.6	102640.0	-6199.7	87197.7			
-11606.0	119302.3	118894.4	121849.4	-5183.7	108613.1			
-10041.2	138587.4	138230.6	140816.1	-4421.8	129234.4			
-8824.2	157640.0	157322.8	159621.1	-3829.1	149326.2			
-7850.6	176529.9	176244.4	178312.9	-3355.0	169047.5			
			number of cars in system	...total surface area saved/recovered w/ Flex (w/ 1000 users)				
			1000.0	-836155.7	-798677.9	-762200.2	-725722.4	-689244.6
			500.0	-24430.8	12046.9	48524.7	85002.5	121480.3
			250.0	-3096.0	33381.8	69859.6	106337.4	142815.1
			166.7	4015.6	40493.4	76971.2	113449.0	149926.8
			125.0	7571.5	44049.2	80527.0	117004.8	153482.6
			100.0	9704.9	46182.7	82660.5	119138.3	155616.1
			83.3	11127.3	47605.0	84082.8	120560.6	157038.4
			71.4	12143.2	48621.0	85098.8	121576.5	158054.3
			62.5	12905.2	49383.0	85860.7	122338.5	158816.3
			55.6	13497.8	49975.6	86453.4	122931.1	159408.9
			50.0	13971.9	50449.7	86927.5	123405.2	159883.0

Chart 10: Surface area saved by use of City-Car (per 1000 users)

Other factors that weigh heavily on the success of the City-Car system are the average number of users per City-Car (1000 users / number of cars in system) and the previous number of cars owned by City-Car new users (forfeited cars per system user). These two factors act as scalars to the system as a whole.

Recovered surface area (sq ft) in Cambridge-MA with Flex City-Car system

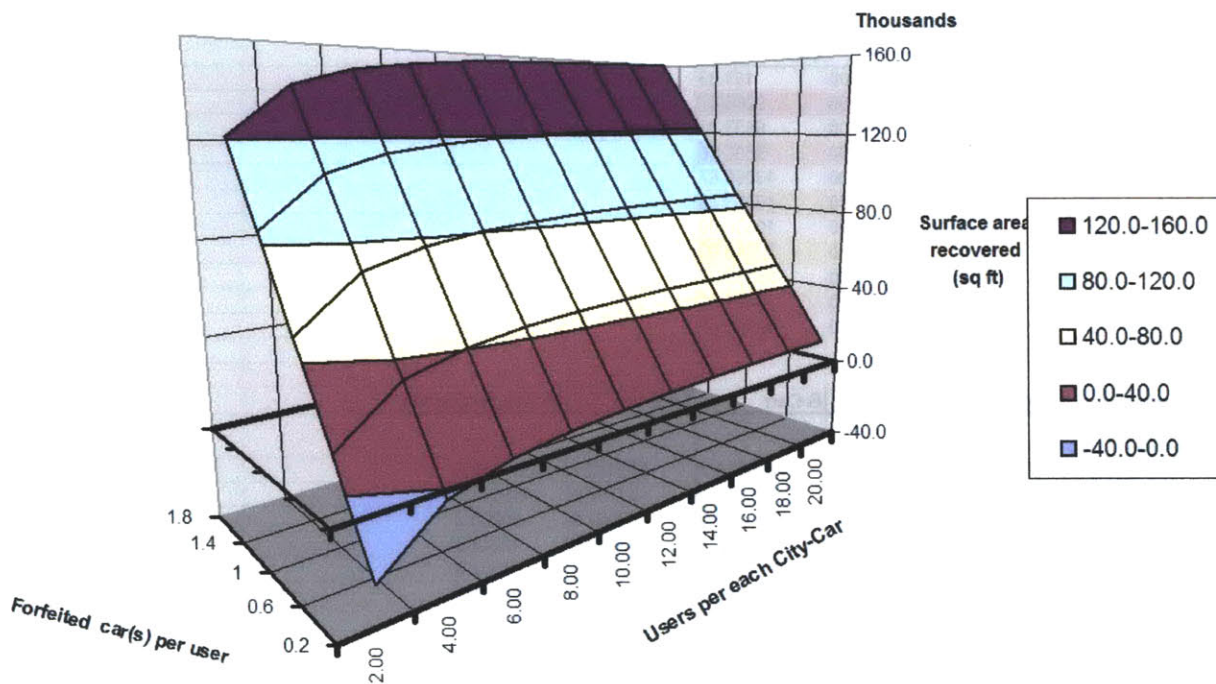

Figure 60: Recovered surface area from three dispensers

The graph (see Figure 60) illustrates the amount of surface area that may be dedicated back to the city, no longer needed for parking, as result of the three dispensers. The returned landscape becomes greatest when multiples of users can share a single vehicle (number of City-Cars is reduced per 1000 users) and when more personal vehicles are forfeited adopting the City-Car system.

Surface area saved per 1000 users (acres)	users per City-Car	10%	20	30	40%	50	60	70%	80	90	100%
2.23	2	4.20	8.41	12.61	16.81	21.02	25.22	29.42	33.62	37.83	42.03
6.42	4	12.10	24.20	36.31	48.41	60.51	72.61	84.71	96.82	108.92	121.02
10.60	6	20.00	39.99	59.99	79.99	99.98	119.98	139.98	159.97	179.97	199.97
14.79	8	27.90	55.80	83.70	111.60	139.50	167.40	195.30	223.20	251.10	279.00
18.98	10	35.80	71.60	107.40	143.19	178.99	214.79	250.59	286.39	322.19	357.99
23.17	12	43.72	87.43	131.15	174.86	218.58	262.29	306.01	349.72	393.44	437.15
27.36	14	51.62	103.23	154.85	206.47	258.09	309.70	361.32	412.94	464.55	516.17
31.54	16	59.50	118.99	178.49	237.98	297.48	356.97	416.47	475.96	535.46	594.95
35.70	18	67.34	134.68	202.02	269.36	336.70	404.04	471.38	538.72	606.06	673.40
39.91	20	75.29	150.59	225.88	301.17	376.47	451.76	527.05	602.35	677.64	752.93

Chart 11: Surface area saved / recovered (per percentage of population adoption)

We can then take a more macroscopic view on all of Cambridge to understand the City-Car system's space-saving influence. Aside from *users per City-Car*, the percent of commuters that adapt to the system determines how many acres of land may be dedicated back to the urban landscape. In an ideal fully saturated system, over 700 acres of paved surface, dedicated solely to parking, may be recovered.

Recovered Surface Area In Cambridge w/ Flex City-Car

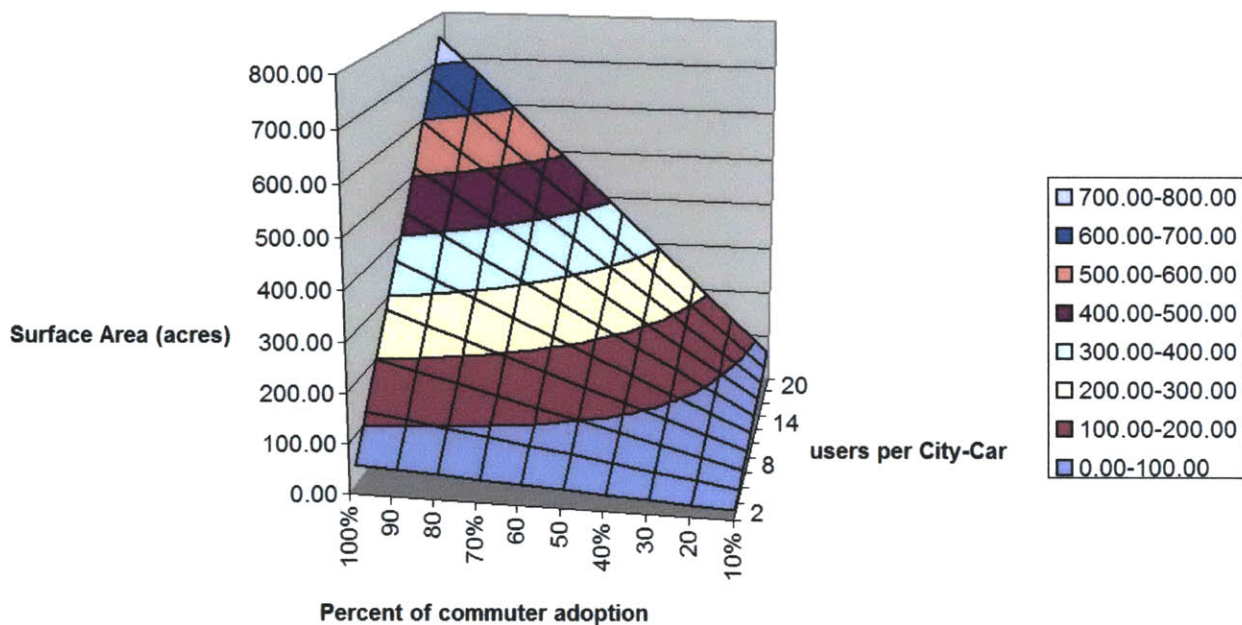

Figure 61: Recovered surface area through all of Cambridge, MA

2

IV Conclusion

Shared vehicle systems work to reduce consumed resources of material and space. However, simply using traditional vehicles within the shared system is not enough, since they are essentially designed to operate completely independent of surrounding vehicles. Nevertheless, providing a unique vehicle, specifically designed to network both physically and digitally in a shared car system, provides a greater impact to the system's environment and to user convenience.

Stripping down the vehicle platform to its bare essentials and promoting a structure to expand upon provides greater material efficiency and reduced energy consumption. Yet, such a system requires significant infrastructural support to manage the multiples of accessories. Such an arrangement may be better served after a shared vehicle system has been well established. Then may we be able to provide more complex functionality at each of the stack dispensers.

A City-Car vehicle, such as the *Flex*, illustrates how important a car design that caters to a shared vehicle system is. Allowing the vehicle to transform to a shorter length may initially seem excessive; however, its space saving capabilities can have a large impact on urban landscape macroscopically. Hundreds of acres of previously paved parking surfaces can be recuperated in an urban setting even with only a fraction of vehicle-commuters adopt the system. Also, the transforming arms of the *Flex* car can offer its user a more engaging driving experience than that of a traditional commuting automobile, attracting a greater market that may not have initially given car sharing a try.

Future steps of the City-Car require further study of both the vehicle and plan of action for implementation. With any transportation system considerable infrastructure to manage the system is needed. The vehicle on the other hand needs continual engineering and design to ensure it meets various user needs. Also, further *Smart Cities* research may be done to create user features that provide on-demand customizing to meet individual preferences.

All in all, considering the impact today's automobile has upon the use of energy, materials and space, we must consider complementary alternatives of transportation to

alleviate these burdens. We must do this not only by focusing on the design of a single efficient vehicle, nor by promoting sole use of public transportation, attempting to dispose of automobiles. Instead we have to consider the symbiotic relationship of both the means of transportation and the system in which it dwells and/or creates.

Thesis Committee

William J. Mitchell

Professor of Architecture and Media Arts and Sciences

Academic Head, Program in Media Arts and Sciences, MIT Media Lab

William J. Mitchell is the Academic Head of the Program in Media Arts and Sciences. Formerly the Dean of the School of Architecture and Planning at MIT, he also directs the Media Lab's Smart Cities research group, and serves as architectural adviser to the President of MIT. Before coming to MIT, he was the Travelstead Professor of Architecture and director of the Master in Design Studies program at the Harvard Graduate School of Design; he has also served as head of the Architecture/Urban Design program at UCLA's Graduate School of Architecture and Urban Planning, and he has taught at Yale, Carnegie-Mellon, and Cambridge universities. Mitchell holds a BArch from the University of Melbourne, an MED from Yale University, and an MA from Cambridge. He is a Fellow of both the Royal Australian Institute of Architects and the American Academy of Arts and Sciences, and a recipient of honorary doctorates from the University of Melbourne and the New Jersey Institute of Technology. In 1997 he was awarded the annual Appreciation Prize of the Architectural Institute of Japan, and he is currently chair of the National Academies Committee on Information Technology and Creativity.

Sanjay E. Sarma

Associate Professor of Mechanical Engineering

Former Chairman of Research and Co-Founder of the Auto-ID Center, MIT

Professor Sanjay E. Sarma has been honored by MIT as a *Cecil and Ide Green Career Development Professor*. His research effort has made significant progress in a number of important areas including, a new haptic device which allows the computer user to physically interact with a virtual representation of the world, a new efficient toolpath generation algorithm for 5 axis machine tools, and a new universal fixturing technology, which promises to convert a machine tool into a rapid prototyping device. He is also developing a new undergraduate subject which integrates finite element analysis in computer aided mechanical design. Professor Sarma also founded the Auto-ID Center with his colleagues, Dr. David Brock and Professor Kai-Yeung Siu. The center's mission is to create an intelligent infrastructure to connect physical objects to the internet and to each other.

Lawrence Sass

Assistant Professor of Architecture

Professor of Computational Design and Fabrication, MIT

Larry Sass is a Professor in the Department of Architecture at the Massachusetts Institute of Technology. The research work attempts to define the use of rapid prototyping and CAD CAM fabrication in design. Current research projects are focused on computational reconstruction and design studies using computer modeling, rapid prototyping and CAD CAM as a representational tool in the design process vs paper drawings. First is the reconstruction of Palladio's un-built works using rapid prototyping tools, a project based on learning about design through a reconstructive process. Second is Design Fabrication, a study focused on designing and fabricating complex shapes and surfaces for buildings using computer modeling and NC tools. His current teaching is in the area of Design Fabrication; that is building design using NC tools as the design process. He received his BArch from Pratt Institute and his masters and PhD from MIT

Axel Kilian

Dipl. Ing.

PhD Candidate in Computation, Department of Architecture, School of Architecture and Planning, Massachusetts Institute of Technology

Axel Kilian holds a Dipl.Ing. in Architecture from the University of the Arts in Berlin, Germany and a Master of Science in Architectural Studies from MIT. In 1998 he was awarded a Fulbright Scholarship to come to the US. Since 2000 he has been a Presidential fellow at MIT for his PhD studies.

In 2004 his work was exhibited in the Venice Biennale, as well as at gardenlab, Los Angeles. He is involved in a wide range of projects from implementing a digital form finding program inspired by Gaudi's hanging chain models, to the design of a concept car at the Media Lab in collaboration with the smart cities group, General Motors and Frank O. Gehry. His work has been published in "Praxis", at Acadia '03 and 04, and most recently in the Non Standard Praxis conference at MIT. In addition he has been a teaching assistant and instructor for several design workshops and studios over the course of his studies.

References

- [1] Barth, M and Todd. (1999). "Simulation Model Performance Analysis of a Multiple Station Shared Vehicle System." *Transportation Research Part C*. Vol. 7, pp. 237-259.
- [2] Barth, M, Xue, Chen, and Todd. "A Hybrid Communication Architecture for Intelligent Shared Vehicle Systems."
- [3] Barth, M, Todd, and Shaheen. (2003). "Intelligent Transportation Technology Elements and Operational Methodologies for Shared-Use Vehicle Systems." *Transportation Research Record*, Transportation Research Board, National Academy of Science, TRB Paper No. 03-4187.
- [4] Barth, M and Todd. (1999). Simulation model performance analysis of a multiple station shared vehicle system. *Journal of Transportation Research Part C: Emerging Technologies*, Vol. 7, pp 237-259.
- [5] Cervero, R and Tsai. (August 2003). San Francisco CityCarShare: Travel-demand Trends and *Second-Year Impacts*. No. 03-05. Abstract: [www-iurd.berkeley.edu/pub/abstract_wp200305.htm](http://www.iurd.berkeley.edu/pub/abstract_wp200305.htm)
- [6] Crandall, D., and Thomas L. (1999). "An Introduction to the Mechanics of Solids, Second Edition." New York; McGraw-Hill.
- [7] Dimas, S. (2003). "AC Propulsion Debuts tzero with Lilon Battery" www.acpropulsion.com
- [8] Gakenheimer, R and Zegras. "Carsharing in Latin America: Examining Prospects in Santiago." In Whitelegg, John and Gary Haq. *The Earthscan Reader on World Transport Policy and Practice*. London: Earthscan, 2003.
- [9] Garrison, William J. and Ward. (2000). *Tomorrow's Transportation: Changing Cities, Economies, and Lives*. Boston, London: Artech House ITS Library.
- [10] Generic Battery Technology Comparison, www.madkatz.com/ev
- [11] Mitchell, W, 2003, *Me++: The Cyborg Self and the Networked City*. Cambridge: MIT Press.
- [12] Mitchell, W., 1999, *e-topia: Urban Life, Jim, But Not as We Know It*. Cambridge: The MIT Press.
- [13] Robotic Parking, www.roboticparking.com
- [14] Shaheen, S. (1999). "Pooled Cars." *Access*. No. 15, Fall 1999.