

# Automatic Acoustic Guitar Tuner

by

Alfredo Bocanegra

Submitted to the Department of Mechanical  
Engineering in Partial Fulfillment of the  
Requirements for the Degree of

Bachelor of Science in Mechanical Engineering

at the

Massachusetts Institute of Technology

June 2005

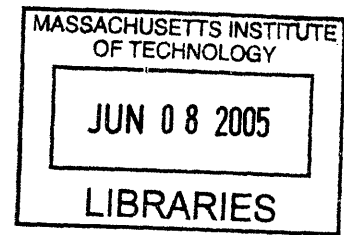

© 2005 Alfredo Bocanegra. All rights Reserved

The author hereby grants to MIT permission to reproduce and to distribute publicly  
Paper and electronic copies of this thesis document in whole or in part.

Signature of Author.....  
Department of Mechanical Engineering  
May 6, 2005

Certified by.....  
Professor Ernesto E. Blanco  
Adjunct Professor of Mechanical Engineering  
Thesis Supervisor

Accepted by.....  
Ernest G. Cravalho  
Chairman, Undergraduate Thesis Committee  
Department of Mechanical Engineering

**ARCHIVES**



# Automatic Acoustic Guitar Tuner

by

Alfredo Bocanegra

Submitted to the Department of Mechanical Engineering  
On May 6, 2005 in Partial Fulfillment of the  
Requirements for the Degree of Bachelor of Science in  
Mechanical Engineering

## Abstract

Acoustic guitar musicians tune their instruments by using a conventional tuner. Individuals pluck the string and the conventional tuner indicates whether the note is sharp or flat. The musician then has to wind the string to increase the tension or loosen it to lessen it. This process can be very cumbersome and inefficient when performing under different weather conditions. This thesis provides the design process of the Automatic Acoustic Guitar Tuner which bypasses the musician and acts as its own feedback system. This new concept will reduce the time needed to tune a guitar by using an electromechanical design to wind and unwind the strings to eventually reach the desired frequency. The Automatic Acoustic Guitar Tuner will also increase the productivity in music classrooms which hold large number of students by reducing the tuning process.

Thesis Supervisor: Ernesto E. Blanco  
Title: Professor of Mechanical Engineering



# Table of Contents

Title	1
Abstract	3
Table of Contents	5
List of Figures	7
1 Introduction	8
1.1 Background	8
1.2 Market Need	9
2 Problem Statement	10
2.1 Current Applications	10
2.2 Problem Solution	11
3 Initial Concepts	12
4 Electrical Design	16
4.1 Relays	16
4.2 Operational Amplifier	17
5 Mechanical Design	19
5.1 Torque Requirements	19

5.2 Motor Selection	20
5.3 Guitar Peg Turner	20
6 Final Design	22
7 Recommendations and Conclusions	26
7.1 Recommendations	26
7.2 Conclusion	27

# List of Figures

Figure 2.1: KORG GA-30 Guitar/Bass Tuner	11
Figure 3.1: Extended arm design	12
Figure 3.2: Tuner directly above string to be tuned	13
Figure 3.3: Grasping handle	13
Figure 3.4: Side view of attaching mechanism	14
Figure 3.5: Isometric view of attaching mechanism	14
Figure 3.6: Reverse isometric view of attaching mechanism	15
Figure 4.1: Relay functions	16
Figure 4.2: Circuitry between conventional tuner and motor	18
Figure 5.1: Motor and gear set	20
Figure 5.2: Delrin rod peg turner	21
Figure 6.1: Automatic Acoustic Guitar Tuner	22
Figure 6.2: Black box containing circuit and power supplies.	23
Figure 6.3: Cylinder containing motor and turning peg.	24
Figure 6.4: Automatic Acoustic Guitar Tuner Setup	25

# Chapter 1

## Introduction

Musicians spend on average ten minutes attempting to tune their musical instruments before every performance and every time there's a change in temperature. Moreover, teachers at the grade school level have to tune their student's musical instruments on an individual basis, which results in a significant amount of time invested on this task. Currently, guitar musicians tune their instruments utilizing conventional tuners. The musician plucks a string then checks the conventional tuner for an indication to see if the note is sharp, flat, or in tune. Based on the feedback from the conventional tuner, the musician adjusts the string tension, increasing or decreasing the sound frequency. This process is repeated until the right frequency is reached for each string. There is a strong need to eliminate and minimize the amount of time spent on manually tuning every string on a musical instrument.

### **1.1 Background**

While performing under different temperatures an acoustic guitar will change in tuning. When a wood instrument changes temperature, the material expands or contracts based on the temperature change experienced. This change can increase or decrease the steel/nylon strings fastened to the guitar. As mentioned earlier, an increase or decrease will change the frequency at which the string oscillates, therefore changing the pitch of the note. A typical guitar has six



strings which are tuned between 329.63Hz for the low E string and 1318.51Hz for the high E. Frequencies between these two values can vary depending on the string and note being tuned.

## **1.2 Market Need**

Musicians can really benefit from the development of such a device. Beginning guitarists find it hard to tune their instrument to the right intervals and are not able to rehearse the right music when practicing with an out-of-tune guitar. Students and professional musicians, across the world, will benefit from such a device by having a perfectly tuned musical instrument that will help them express their true artistic talent. In addition, acoustic guitars are portable but require tuning in various temperatures which can be cumbersome at times. All this can be prevented by using a detachable tuner that can perform these tasks for you.

After talking to various musicians and explaining the concept of this new tuner, their reaction was favorable in the sense that they would definitely buy it if priced accordingly. Current conventional tuner prices can range from \$20-\$200, the more expensive the tuner, the higher the quality and precision. Developing an automatic tuner, that will replace the conventional tuner, will prove beneficial in education and in artistic venues; as well as open new doors to the implementation of Mechanical Engineering to musical instruments.

# Chapter 2

## Problem Statement

Tuning can become a challenge when the musician is a beginner or when time is of importance. When analyzing the time it takes to tune the instrument, the bottle neck in the process becomes the musician. He or she receives a signal from the conventional tuner which indicates whether to increase or decrease the tension on the string, changing the string's frequency. The time delay between receiving the indication and taking action can be minimized by bypassing the musician and automating the process.

### 2.1 Current Applications

The KORG GA-30 Guitar/Bass tuner shown in Figure 2.1 below gives the indication to the musician by lighting a Light Emitting Diode (LED), which indicates which way the string needs to be adjusted. The microphone detects a frequency and decides whether the note is sharp, flat, or in-tune. This signal then turns the corresponding LED's ON or OFF. From here it is up to the musician to repeat the task until a satisfying frequency is achieved.

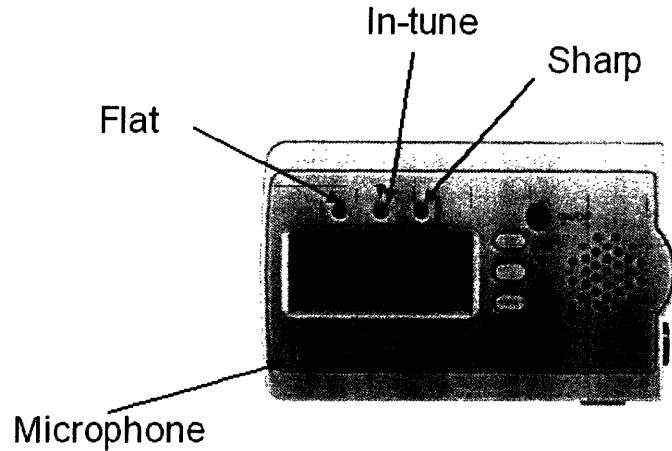

Figure 2.1: KORG GA-30 Guitar/Bass Tuner

This process can become cumbersome and time consuming if the musician does not possess the ability to tighten or loosen the string with enough accuracy to avoid overshoot, passing the “in-tune” frequency range.

## 2.2 Problem Solution

An automated tuner can significantly reduce the amount of time that is spent tuning an acoustic guitar. To achieve this solution, a tuner that bypasses the human using a closed loop feedback control system was developed. The feedback control system can be coupled with already existing tuner technology such as the KORG GA-30 in order to effectively tune each string. A simple pluck of the string will be needed to effectively tune the string. The human ear can only detect frequencies to a limited accuracy, while a current tuner can detect them with more accuracy and send the signal to the Automatic Acoustic Guitar Tuner to tune with higher precision. The integration of a closed loop feedback circuit will trigger the mechanical component to give the desired effect and achieve “in-tune” frequency.

# Chapter 3

## Initial Concepts

Various concepts were approached, all with the same final result in mind. The Automatic Acoustic Guitar Tuner must have a mechanical system that will be triggered by an electrical component which in turn will receive the signal from the conventional tuner. A variant of the Automatic Acoustic Guitar Tuner will be able to attach to the guitar while in use and tune the string automatically with just one pluck.

The first concept consisted of attaching a device to the guitar at the top of the tuning section as shown in Figure 3.1 and extending an arm to each of the pegs.

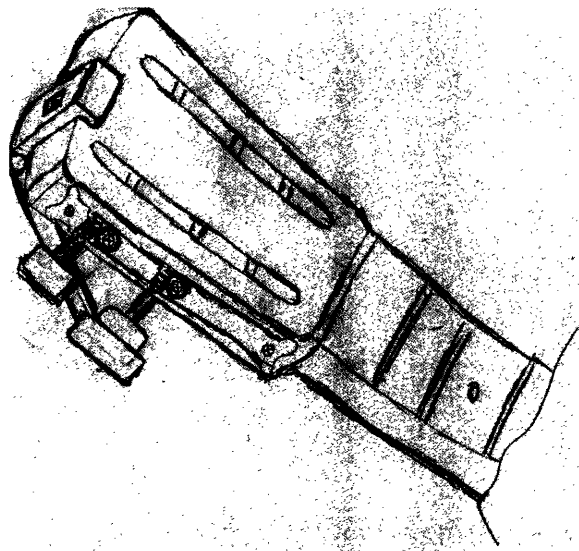

Figure 3.1: Extended Arm Design

Design in Figure 3.1 proved to be too complicated to transfer the needed torque to the arm from the motor.

The second design shown in Figure 3.2 below was drafted in order to do away with this problem. This design has the tuner directly on top of the string's winding mechanism which does away with the arm needed for torque transfer.

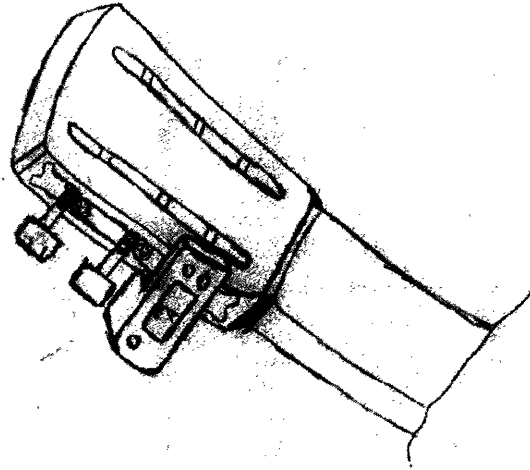

Figure 3.2: Tuner directly above string to be tuned.

From this design, a grasping mechanism was also to be developed as shown in Figure 3.3 bellow.

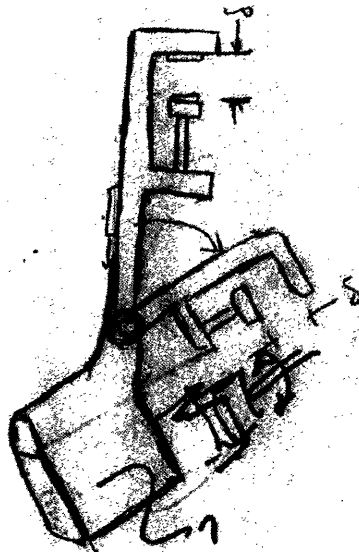

Figure 3.3: Grasping handle

The  $\delta$  denotes the thickness of the guitar handle which the tuner should be able to grasp.

Solid modeling of the possible design can be seen in Figures 3.4 through 3.6 below.

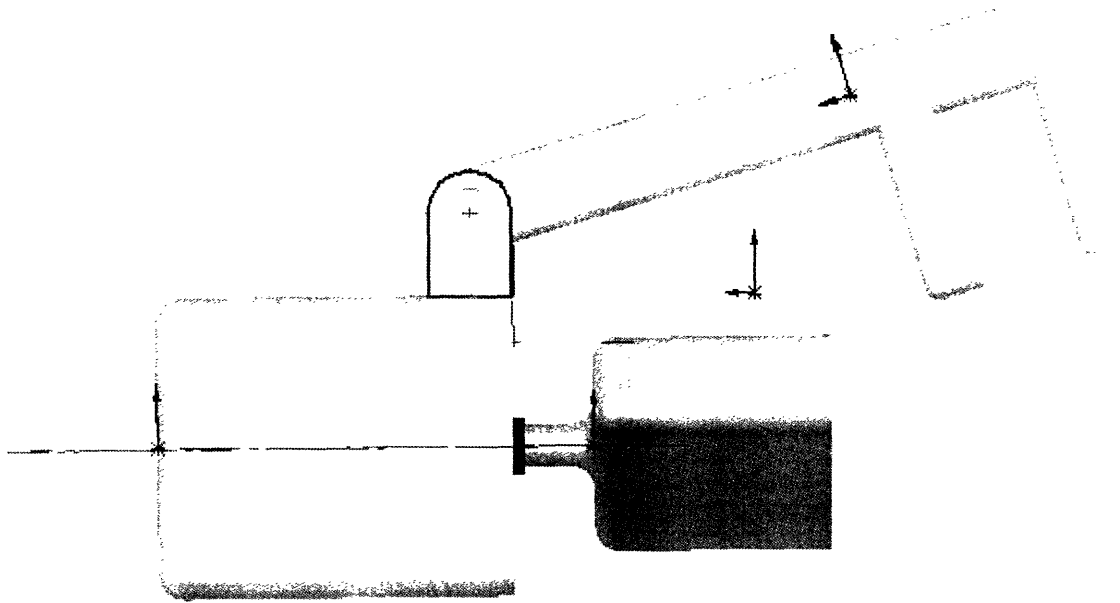

Figure 3.4: Side view of attaching mechanism

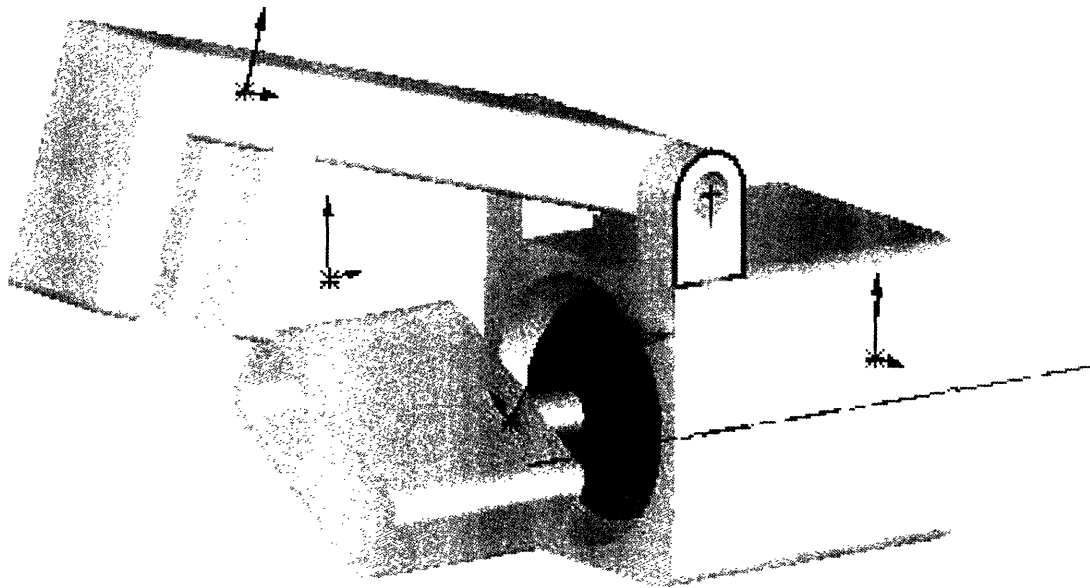

Figure 3.5: Isometric view of attaching mechanism

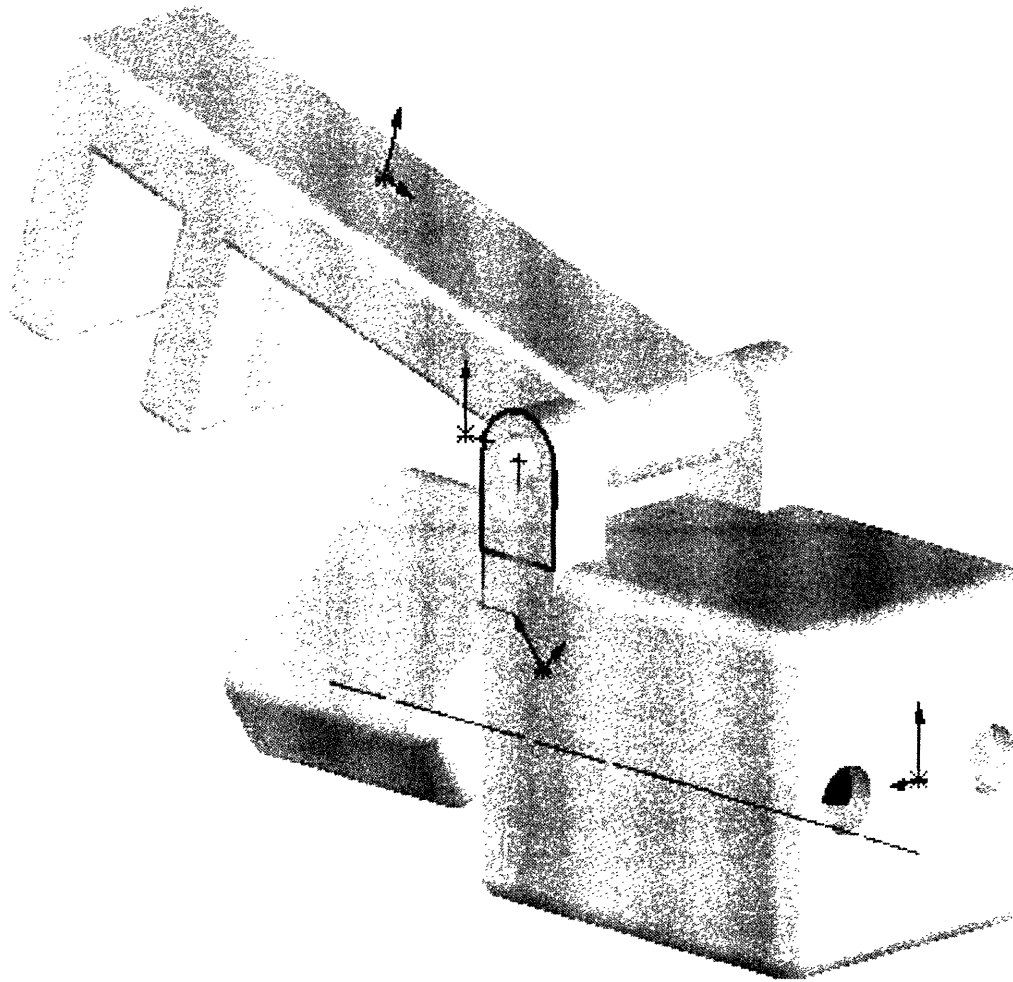

Figure 3.6: Reverse isometric view of attaching mechanism

# Chapter 4

## Electrical Design

The Automatic Acoustic Guitar Tuner needed a circuit that would interpret the signal from the conventional tuner and turn it into an input voltage to the mechanical component.

### 4.1 Relays

At first the concept of an electromagnetic relay switch was explored. As shown in Figure 4.1, applying current to a coil causes electromagnetic fields to be created which can pull contact leads together.

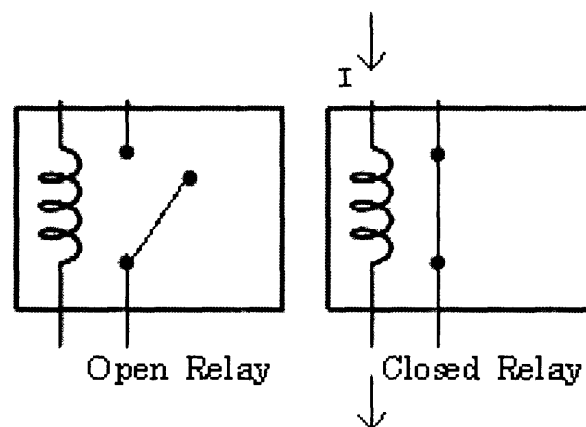

Figure 4.1: Relay functions

The contact leads can be right beside (or above) the coil. Whenever an LED is active, current passes through it which can act as a trigger. For example, in Figure 2.1 we can see a couple of



LED's which denote if the note is sharp or flat. These LED's usually tell the musician to wind or unwind the string in order to achieve the right frequency, but in this case the LED's would trigger a relay which will then close the motor's circuit giving the right amount of winding to the string. Once the LED turns off, then the relay will go back to its original open position and not let any current to the motor, stopping the winding. This will indicate that the right frequency has been reached.

## **4.2 Operational Amplifier**

Although a relay seemed a viable option, the response time would have not been ideal for this application. Relays can also be bulky in size, and did not meet the voltage specifications needed to get triggered by the LED's. A Linear Technology LT1886 Dual 700MHz, 200mA Operational Amplifier was chosen for our circuit. Figure 4.2 shows the circuit which connects the LED's from the conventional tuner, the operational amplifier, resistors, diodes, power supply, and finally the motor. The diodes in anti-parallel configuration were inserted into circuit to cut-off any small voltages that might send a false signal to the operational amplifier. Preventing small voltages to pass to the operational amplifier will reduce the noise and unnecessary motor response. The 1.5K $\Omega$  and 100k $\Omega$  resistors were inserted to achieve enough gain between the LED voltage input and the desired output voltage to be applied to the motor. The final 10k $\Omega$  resistor was inserted to differentiate between the two inputs into the operational amplifier. If there exists an overshoot there is the possibility that both LED's may be turned "ON" at the same time. The latter one would have greater voltage since it will be receiving a voltage at that time. The LED that had been "ON" will have some remaining voltage but will be less due to the 10k $\Omega$  resistor in place impeding the current to flow by.

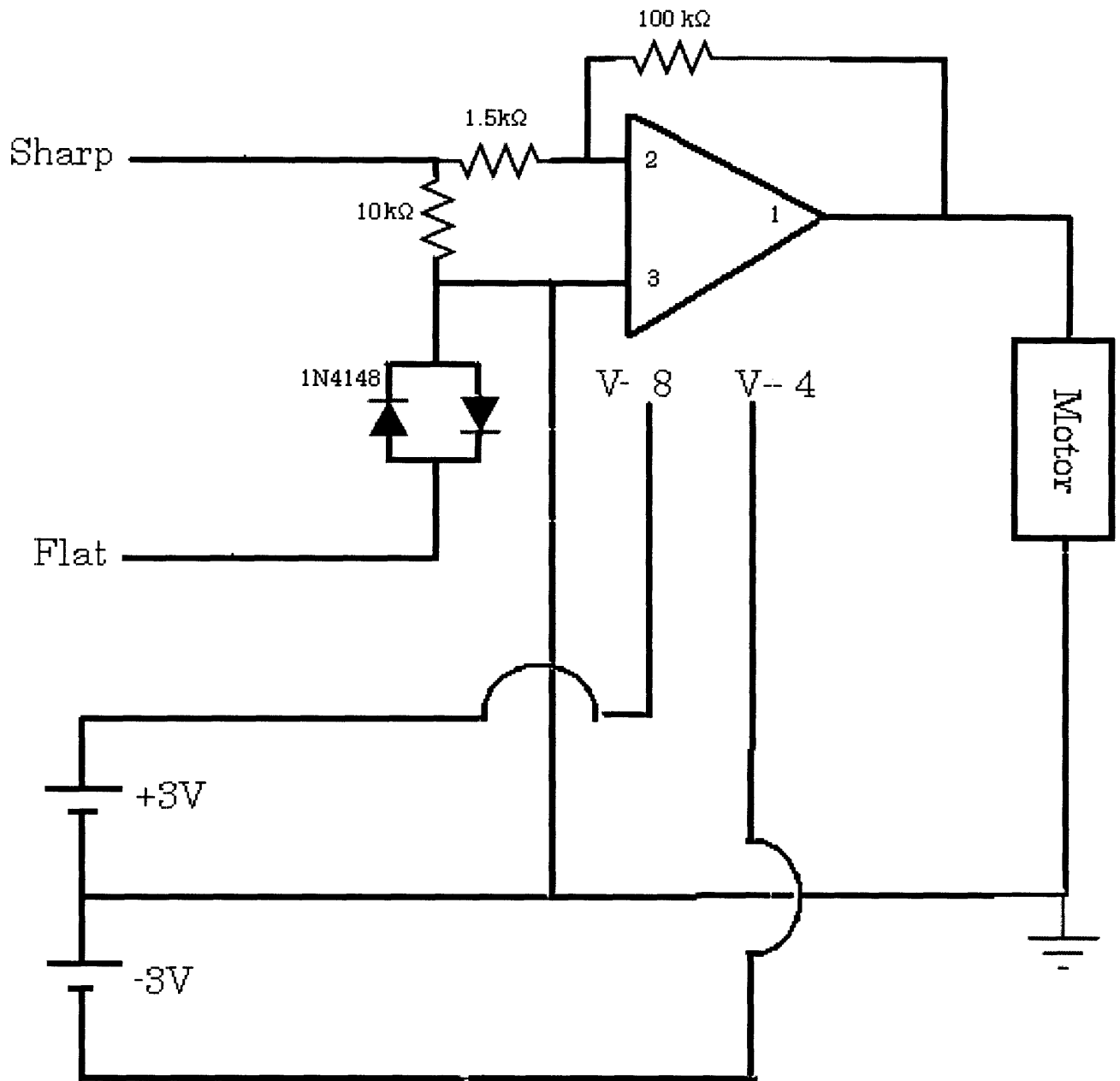

Figure 4.2: Circuitry between conventional tuner and motor.

# Chapter 5

## Mechanical Design

The mechanical design was concentrated in specific by the torque needed to turn the guitar peg and effectively wind the string. Attaching the actual motor to the guitar was left as a manual option for the musician for ease of removal and reconnection.

### 5.1 Torque Requirements

The torque required to turn the guitar peg was calculated by applying an arm to the tuning peg and adding a known mass,  $M$ , at a known distance,  $D$ . The force,  $F$ , applied to the arm was calculated using Equation 1 where  $g$  denotes the value of gravity.

$$F = M * g \quad (1)$$

Both  $F$  and  $D$  were then entered into Equation 2 below which determined the torque needed to initiate rotation.

$$\tau = F \times D \quad (2)$$

The torque required to be applied by the motor was to be 2.4 (in) (lbs).

## 5.2 Motor Selection

A motor which could withstand a heavily geared setup needed to be chosen. The motor used was the Tamiya RC-260, which utilizes carbon brushes for long life. The motor operates on 3V and can operate up to 4.5V but not over. The tuning peg needs to be able to turn at a slow enough rotational frequency so that the guitar string would not break due to excessive tension. The motor operates at about 690Hz when measured with a strobe light. The frequency desired was calculated to be about .5 Hz which translates to about half a turn per second.

A large gear set was to be implemented. The motor chosen was conveniently part of a planetary gear box set. A gear ratio of about 2000 to 1 was assembled into the setup in order for the frequency to drop low enough into our desired .5Hz. Figure 5.1 below shows a solid modeling of the actual motor and gear set used.

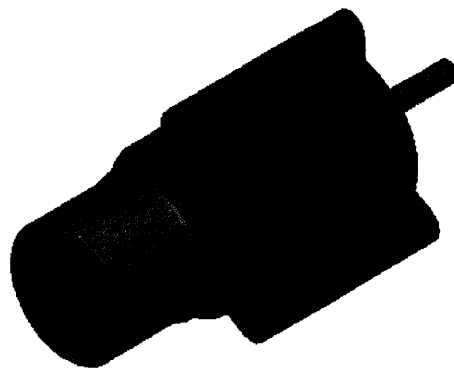

Figure 5.1: Motor and gear set.

## 5.3 Guitar Peg Turner

As you can see in Figure 5.1, the shaft cannot actually turn the guitar peg since it does not possess a set of thongs or a grasping mechanism. In order to effectively turn the guitar peg; a peg turner was machined from delrin rod material as shown in Figure 5.2.

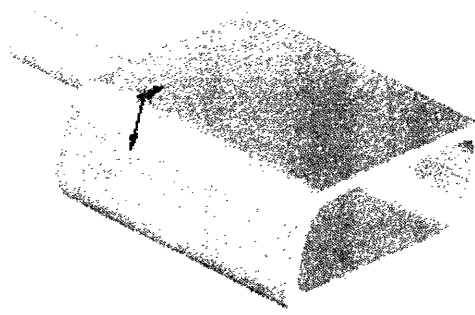

Figure 5.2: Delrin rod peg turner

Enough clearance inside the pocket of the peg turner was left so not only one guitar but many different sizes of guitars can be tuned regardless of their peg dimensions. The extending arm attaches itself to the motor shaft through a pin.

# Chapter 6

## Final Design

Figure 6.1 below shows the final design of the Automatic Acoustic Guitar Tuner.

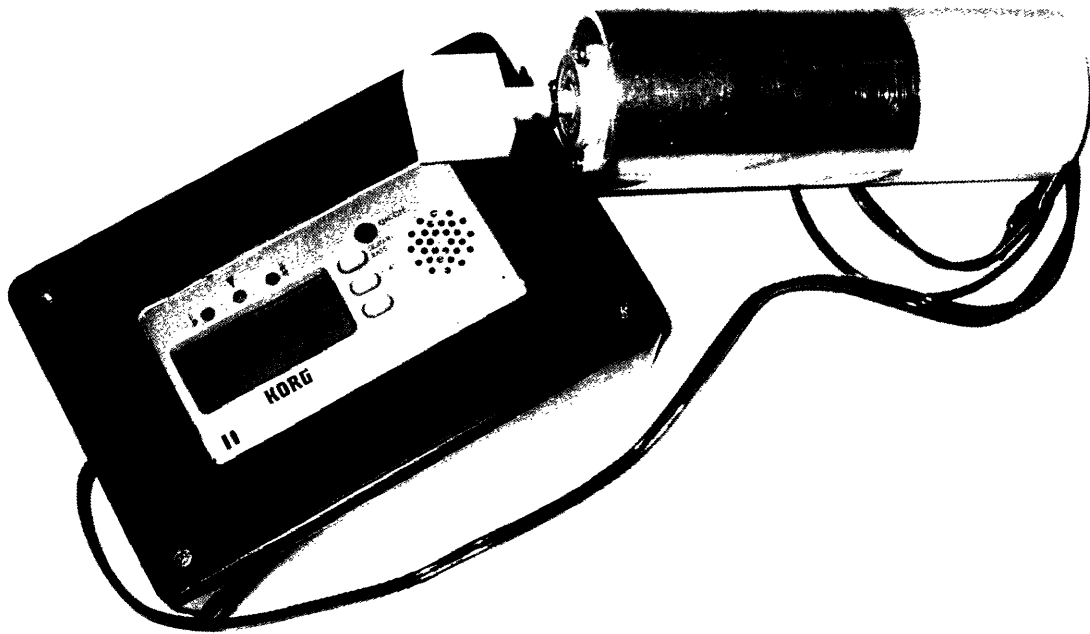

Figure 6.1: Automatic Acoustic Guitar Tuner

The final design divides the Automatic Acoustic Guitar Tuner into two components. The black box seen in Figure 6.2 is the control section which holds the circuitry and power supplies.



Figure 6.2: Black box containing circuit and power supplies.

The cylinder shown in Figure 6.3 below holds the motor and the peg turner which will be handheld by the musician in order to facilitate switching between strings. The cylinder is made out of aluminum while the bottom piece was machined using a delrin rod. The motor screws into the delrin rod at the bottom of the cylinder using the three screws from the motor.

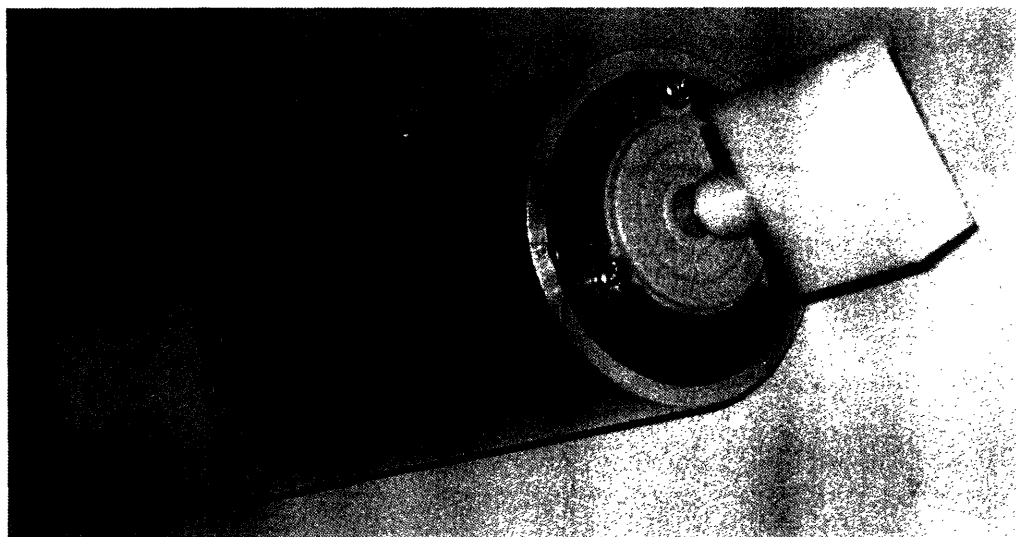

Figure 6.3: Cylinder containing motor and turning peg.



Figure 6.4 shows the Final Product while in use by the musician. As you can see, it is very simple to operate the Automatic Acoustic Guitar Tuner.



Figure 6.4: Automatic Acoustic Guitar Tuner Setup

# Chapter 7

## Recommendations and Conclusion

### 7.1 Recommendations

The Automatic Acoustic Guitar Tuner is functional but has yet to reach its full potential. A technical component that needs to be analyzed more in the depth is the operational amplifier. Currently this amplifier supplies a peak output current of 200mA, which might be too small to maintain the motor working at higher torque requirements. A different operational amplifier that can and may be used is the LT1210 from Linear Technologies. The output current for this latter operational amplifier is rated at 1.1A which increases the current five-fold. Minimizing the packaging is of essence for a final product. The electrical components along with the batteries of the Automatic Acoustic Guitar Tuner can be minimized in size to be confined in one handheld product, similar to a flashlight or highlighting marker. Design for manufacturing and production are the next steps to be taken to ensure this product delivers the benefit it possesses to the market in need. Designing the product with aesthetics and ergonomics in mind will reduce the size and increase the attractiveness.

## **7.2 Conclusion**

Notwithstanding the previous recommendations, the Automatic Acoustic Guitar Tuner is the 8<sup>th</sup> marvel of the world. After using the tuner several times, the hardship tuning process became less stressful. The market for such a product is great in size which would definitely yield for production. This product works for professional musicians as well as for beginning students which have the enthusiasm but lack the skills to tune a guitar. The Automatic Acoustic Guitar Tuner will increase productivity in the classroom and stimulate the creation of many musical masterpieces.