

**Enhancement of Electromagnetic Propagation  
Through Complex Media for Radio Frequency  
Identification**

by

Uttara P. Marti

Submitted to the Department of Electrical Engineering and Computer  
Science

in partial fulfillment of the requirements for the degree of

Master of Engineering

at the

MASSACHUSETTS INSTITUTE OF TECHNOLOGY

June 2005

© Uttara P. Marti, MMV. All rights reserved.

The author hereby grants to MIT permission to reproduce and  
distribute publicly paper and electronic copies of this thesis document  
in whole or in part.

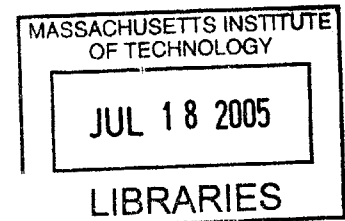

Author .....  
Department of Electrical Engineering and Computer Science  
May 19, 2005

Certified by .....  
Daniel W. Engels  
Research Scientist  
Thesis Supervisor

Accepted by .....  
Richard C. Smith  
Chairman, Department Committee on Graduate Students



# Enhancement of Electromagnetic Propagation Through Complex Media for Radio Frequency Identification

by

Uttara P. Marti

Submitted to the Department of Electrical Engineering and Computer Science  
on May 19, 2005, in partial fulfillment of the  
requirements for the degree of  
Master of Engineering

## Abstract

In this thesis, I present and examine the fundamental limitations involved in Radio Frequency Identification (RFID) as well as provide a means to improve reader-tag communication in ultra high frequency RFID systems. The ultimate goal in an RFID system is to maximize the communication link between the reader and the tags while, at the same time, minimizing the effect of product material, geometry and orientation. Reader-tag communication has improved significantly over the past five years, however, tag operations continue to be extremely sensitive to their environment. Ultra high frequencies present unique problems in transmission, generation and circuit design that are not encountered at lower frequencies. Based on the fundamental constraints on these passive RFID systems, such as electromagnetics, power limitations and government regulations, I analyzed electromagnetic propagation through materials as applied to RFID tagged cases and pallets. Applying the electromagnetic concept of conductive parallel plates to enhance electromagnetic power to RFID tagged cases and pallets, I suggest an alternative to the current pallet structure.

Thesis Supervisor: Daniel W. Engels

Title: Research Scientist



## Acknowledgments

When I arrived at the Auto-ID Labs in May 2004, I had a limited background in the areas that I have concentrated on in this thesis. I wish to thank my advisor, Dr. Daniel Engels, for allowing me the opportunity to explore a field in which I had no previous research experience. Dan allowed me tremendous freedom in narrowing a topic in preparation for my thesis. Through our sponsorship meetings and discussions, I have been given the opportunity to explore many topics and I have learned an incredible amount about RFID technology and the industry as a whole.

I owe much of my knowledge of electromagnetics and RFID technology to my project supervisor and mentor, Dr. Rich Fletcher. While Dan provided me with flexibility in my research, Rich provided me with motivation and focus. Our weekly meetings were always stimulating and helpful. Without Rich's continuous advising, I would have overlooked much of what is required in conducting thorough research in preparing a master's thesis.

I would also like to thank those involved in the Packaging and RFID Special Interest Group at the Auto-ID Labs. Rich Redemske, Jonathon Wolk and Tom Scharfeld created an atmosphere in the Labs that made research and work productive, exciting, painless and fun.

I have to thank my friends for making my MIT experience truly memorable. HongJoo for being the closest to a sister I will ever have; Solon for his constant advocacy of the field of engineering; Shawn for sparking my initial interest in electromagnetics; and last and certainly not least, Arthur and Priya for giving me the necessary motivations and distractions to help me to complete my thesis.

Finally, I must thank my family. Harsha, my older brother, for being my idol, constantly telling me that I am brilliant, and for being proud of me. Dhanu, my cousin, for teaching me of the benefits of graduate school, research and  $\text{\LaTeX}$ . Most of all, I would like to thank Amma and Nanna for offering their advice, wisdom, inspiration, experience, food and love even when they *really* did not have the time or energy.



# Contents

<b>1</b>	<b>Introduction</b>	<b>13</b>
1.1	Introduction . . . . .	13
1.2	The History of RFID Technology . . . . .	15
1.3	The Fundamentals of RFID Technology . . . . .	17
1.3.1	Passive RFID Systems . . . . .	17
1.3.2	Active RFID Systems . . . . .	18
1.4	Coupling . . . . .	19
1.4.1	Inductive Coupling . . . . .	19
1.4.2	Propagation Coupling . . . . .	20
1.5	Variables That Affect Performance . . . . .	20
1.5.1	Antenna Detuning . . . . .	21
1.5.2	Attenuation . . . . .	21
1.5.3	Interference . . . . .	22
1.6	Assumptions and Thesis Overview . . . . .	22
1.6.1	Assumptions . . . . .	23
1.6.2	Organization . . . . .	23
<b>2</b>	<b>Electromagnetic Wave Theory</b>	<b>27</b>
2.1	Introduction . . . . .	27
2.2	Maxwell's Equations . . . . .	27
2.2.1	Free Space Characterization . . . . .	29
2.2.2	Wave Equation and Solution . . . . .	29
2.2.3	Poynting's Theorem and Time-Average Power Vector . . . . .	31

2.3	Antennas . . . . .	32
2.3.1	Hertzian Waves and the Hertzian Dipole . . . . .	32
2.3.2	Special Cases . . . . .	33
2.3.3	Impedance and Efficiency . . . . .	35
2.3.4	Resonant Frequency and Bandwidth . . . . .	36
2.3.5	Radiation Pattern . . . . .	37
2.3.6	Gain . . . . .	37
2.3.7	Polarization . . . . .	38
2.4	Sources of Attenuation . . . . .	38
2.4.1	Antennas in the Field . . . . .	38
2.4.2	Temperature and Environmental Influences . . . . .	38
2.5	Summary . . . . .	39
<b>3</b>	<b>Study of Wave Propagation</b>	<b>41</b>
3.1	Introduction . . . . .	41
3.2	Electromagnetic Propagation . . . . .	41
3.3	Theoretical Measurements . . . . .	42
3.4	Experimental Measurements . . . . .	42
3.5	Experimental Results . . . . .	44
3.6	Experiment Discussion . . . . .	46
3.7	Summary . . . . .	46
<b>4</b>	<b>Wave Guidance</b>	<b>47</b>
4.1	Introduction . . . . .	47
4.2	Modes of Propagation . . . . .	48
4.2.1	TE Modes . . . . .	48
4.2.2	TM Modes . . . . .	49
4.3	TE Field Components in the Waveguide . . . . .	49
4.4	TM Field Components in the Waveguide . . . . .	50
4.5	Cutoff Frequency . . . . .	51
4.6	Power Density . . . . .	52



4.7	Conductive Layering in RFID Systems . . . . .	52
4.7.1	Proposed Pallet Structures . . . . .	53
4.8	Summary . . . . .	56
<b>5</b>	<b>Conductive Layering in Pallets</b>	<b>59</b>
5.1	Introduction . . . . .	59
5.2	Study 1: Propagation into Pallet Layers . . . . .	59
5.2.1	Structure 1 . . . . .	60
5.2.2	Structure 2 . . . . .	61
5.2.3	Structure 3 . . . . .	61
5.2.4	Study 1 Analysis . . . . .	61
5.3	Study 2: Propagation Along Pallet Layers . . . . .	63
5.3.1	Structure 1 . . . . .	63
5.3.2	Structure 2 . . . . .	63
5.3.3	Structure 3 . . . . .	65
5.3.4	Study 2 Analysis . . . . .	65
5.4	Summary . . . . .	66
<b>6</b>	<b>Studying Structure 1 in Depth</b>	<b>67</b>
6.1	Introduction . . . . .	67
6.2	Study 3: Propagation into Structure 1 . . . . .	68
6.2.1	903 MHz . . . . .	68
6.2.2	915 MHz . . . . .	68
6.2.3	927 MHz . . . . .	70
6.2.4	Study 3 Analysis . . . . .	70
6.3	Study 4: Tag Placement Using Conductive Plates . . . . .	71
6.3.1	Foil Layers at a Spacing of <i>5cm</i> . . . . .	72
6.3.2	Foil Layers at a Spacing of <i>10cm</i> . . . . .	72
6.3.3	Foil Layers at a Spacing of <i>15cm</i> . . . . .	73
6.3.4	Conductive Ink Layers at a Spacing of <i>5cm</i> . . . . .	73
6.3.5	Conductive Ink Layers at a Spacing of <i>10cm</i> . . . . .	74

6.3.6	Conductive Ink Layers at a Spacing of 15cm . . . . .	74
6.3.7	Study 4 Analysis . . . . .	76
6.4	Summary . . . . .	77
<b>7</b>	<b>Practical Applications</b>	<b>79</b>
7.1	Introduction . . . . .	79
7.2	Reflections . . . . .	79
7.3	Air Gaps . . . . .	82
7.4	Summary . . . . .	82
<b>8</b>	<b>Conclusion</b>	<b>85</b>
8.1	Conclusion . . . . .	85
8.2	Future Work . . . . .	87
<b>A</b>	<b>Glossary</b>	<b>89</b>

# List of Figures

1-1	Example of a typical passive RFID tag. . . . .	14
1-2	Example of a typical warehouse pallet structure. . . . .	23
2-1	Geometric arrangement of an infinitesimal dipole and its associated field components. . . . .	33
2-2	Radiation power pattern of a dipole. . . . .	36
3-1	Electromagnetic penetration to the center of a pallet. . . . .	42
3-2	Plot of computed transmission coefficient for water as a function of thickness. . . . .	43
3-3	Illustration of setup used for measurements. . . . .	43
3-4	Measured results using a field probe. . . . .	44
3-5	Measured results using an RFID tag. . . . .	45
4-1	Parallel-plate waveguide. . . . .	47
4-2	Tagging of individual cases on a pallet. . . . .	53
4-3	Structure 1: Vertically oriented, linearly polarized reader antenna. . .	54
4-4	Structure 2: Horizontally oriented, linearly polarized reader antenna. .	55
4-5	Structure 3: Circularly polarized reader antenna. . . . .	57
5-1	Power measured at the end of Structure 1 using a Kushcraft antenna. . .	60
5-2	Power measured at the end of Structure 2 using a Kushcraft antenna. . .	61
5-3	Power measured at the end of Structure 3 using a Kushcraft antenna. . .	62
5-4	Power measured along Structure 1 using a folded dipole antenna. . . .	64
5-5	Power measured along Structure 2 using a folded dipole antenna. . . .	64

5-6	Power measured along Structure 3 using a folded dipole antenna. . . .	65
6-1	Power measured at the end of Structure 1 using a tag emulator. . . .	69
6-2	Power measured at the end of Structure 1 using a tag emulator. . . .	69
6-3	Power measured at the end of Structure 1 using a tag emulator. . . .	70
6-4	Power measured along Structure 1 using a dipole probe and a 5cm separation. . . . .	72
6-5	Power measured along Structure 1 using a dipole probe and a 10cm separation. . . . .	73
6-6	Power measured along Structure 1 using a dipole probe and a 15cm separation. . . . .	74
6-7	Power measured along Structure 1 using a dipole probe and a 5cm separation. . . . .	75
6-8	Power measured along Structure 1 using a dipole probe and a 10cm separation. . . . .	75
6-9	Power measured along Structure 1 using a dipole probe and a 15cm separation. . . . .	76
7-1	Reflected and transmitted waves in different materials. . . . .	80
7-2	Layer dimensions in a mixed pallet. . . . .	81
7-3	Air gaps in casing can be used to channel the power to the center of a pallet structure. . . . .	83
7-4	Air gaps in casing can be combined with products that perform similar to air to create reflective channeling of power. . . . .	84

# Chapter 1

## Introduction

### 1.1 Introduction

Radio Frequency Identification (RFID) systems are used to communicate the identity of an object through radio frequency waves. The identity of these objects are transmitted wirelessly in the form of a unique serial number in order to reduce the amount of time and manual labor involved in capturing data as well as to increase the accuracy of data collection. While a bar-code system requires a person to manually scan a label or tag to collect information, RFID systems are able to collect data and transmit to data systems without involving a human.

Through the use of the Internet, the problem of delivering information has been made inexpensive and relatively sophisticated; however, collecting basic information is often complicated as well as expensive. RFID systems provide an extremely low cost and relatively less complex means of automatically capturing information. Attaching tags to the necessary objects and creating a network of reading devices, RFID is designed to capture data and transmit it to an information system without requiring a person to be involved.

A typical RFID tag, as shown below in Figure 1.1, is made up of a microchip (or strap) attached to an antenna which are together mounted on a substrate. These chips can store as much as 2 kilobytes of information ranging from the product name, shipment, date of manufacture and destination for that item. To retrieve the data

that is stored on the tag's chip, a reader must be used. Typical readers are made up of one or more antennas that communicate by transmitting radio waves as well as receiving signals from the tags. This information is then passed in digital form through a computer system.

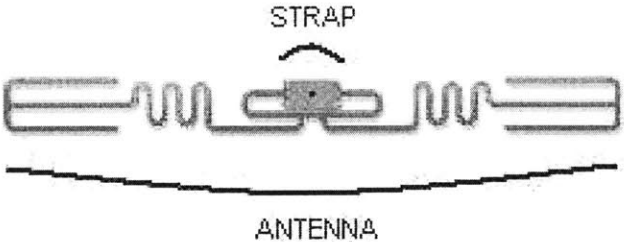

Figure 1-1: Example of a typical passive RFID tag.

Many of today's current solutions require manual data entry, or the scanning of barcodes manually. These manual solutions are not only timely and expensive, but they also lead to large amounts of data inaccuracy. RFID allows the transmission, reception and collection of object data without using line of sight and with limited need for manual assistance.

While the technology has been readily available for more than 15 years RFID use has been limited to closed loop and high value applications, until recently, due to the traditionally high cost. With increased improvements, innovations and adoption of the technology for various applications, there have been significant increases in the performance of RFID systems as well as decreases in the costs.

Many companies have adopted the technology as a means of tracking parts within the warehouse during the manufacturing process. As many of these parts are tracked using reusable containers, the tags can be reused as well, justifying the cost of the tags by the savings generated by the use of the RFID system.

When RFID tags are placed on cases and pallets where products are being exchanged between multiple companies, as in the supply chain, cost have been a major deterrent to adoption of the technology. Tags are essentially disposable because they are thrown out with the cartons they are placed on. While tags that are built onto

pallets could be reused, technology to develop ways to recycle tags on corrugate cases are still being investigated.

Today tags cost between 20 and 40 cents depending on their chip and packaging, which is several years away from the 5-cent tag goal that has been dictated by the user community. Though passive RFID systems have the potential to offer an inexpensive and less restricted means of capturing data, there are still many structural and operational constraints involved in the use of the technology. In this thesis, I analyze some of these constraints as well as suggest a few potential solutions to these fundamental constraints.

## 1.2 The History of RFID Technology

In 1999, the Uniform Code Council, Gillette and Procter & Gamble worked together to fund the Auto-ID Center at the Massachusetts Institute of Technology. The center aimed at looking at private industry and developing an RFID tag that could be relatively inexpensive at high manufacturing volumes. With the support of the U.S. Department of Defense and 9 of the top 10 retailers worldwide, RFID has now become a more commonly accepted technology.

Many companies are now attracted to RFID because the technology has the potential at any given time to know the precise location of an object regardless of its location in the supply chain. However, RFID, as it is generally known today, has undergone many significant changes since its development in early aircraft systems.

While today the technology has undergone many developments, the first common use of RFID technology was during World War II. The military forces of the world were using radar to be warned of approaching planes even at large distances. However, these radar devices did not hold information as to whether or not these planes were friend or foe.

The Germans discovered that rolling their planes when they were returning to their base altered the radio signal that was reflected back to their radar devices; therefore providing a primitive passive RFID system of alerting their own soldiers that they

were not an enemy plane.

The British developed an active identification system, called Identity Friend or Foe (IFF), by placing transmitters on their planes. When grounded radar stations transmitted signals, the plane transmitters would receive this signal and broadcast a signal back that indicated that their plane was friendly.

RFID technology works very similarly to the IFF system. A signal is sent by the reader to a tag. In a passive system, this signal will be recognized by the tag and “wake” the tag up allowing the tag to communicate back a signal. In an active system, the tag may constantly broadcast a signal in regular intervals.

Early advances in radio frequency (RF) communications applied RF energy towards remotely identifying objects. Devices were developed to counter theft, monitor payments in stores and security systems. Through the 1980s and 1990s, companies began the development of RFID operation at multiple frequencies. With this, performance and accuracy improved, driving down the price of new applications of the technology. With the ready availability of the Internet globally, RFID systems have been expanded to numerous everyday uses such as access control, tolling, inventory management and other security applications.

The majority of these technologies rely on the use of low and high frequency ranges. Finally in the early 1990s, engineers developed an ultra high frequency (UHF) RFID system, as UHF offers longer read range and speedier collection and retrieval of data. Initial pilots of the technology were expensive due to the low volume of sales and the relatively poor performance of the commercial systems.

The Auto-ID Center, founded at MIT in October 1999, opened global research labs allowing the development of interface protocols, a network architecture for capturing and retrieving tag data via the Internet as well as the Electronic Product Code (EPC); a serial number that has numbers to identify the manufacturer, product category and the individual item. When RFID technology was more universally adopted by global companies, the Uniform Code Council licensed the Auto-ID Center’s technology and created EPCglobal in order to commercialize and standardize EPC technology. The Auto-ID Center transformed in October of 2003, to become the Auto-ID Labs. The



research responsibilities of the Auto-ID Labs continue efforts to research and develop standards for RFID technology and its applications.

## 1.3 The Fundamentals of RFID Technology

There are various types of radio frequency identification technologies available today. This section explains the difference between active and passive tags and between low, high and ultra high frequency systems. In this thesis, I will concentrate on passive tags in ultra high frequency systems; however, I will briefly discuss these other classifications of RFID systems.

As RFID has gone through various stages of classification, there are a few different types of systems that have been developed. RFID refers to a range of devices that are used in identification. All RFID systems, however, are composed of readers and tags. Readers may be considered to be “access points” that collect information from tags. Tags are affixed to items of interest that will be identified.

The majority of deployed RFID tags use a silicon microchip in order to store data about their unique identity. There are two fundamental classifications of RFID systems; *passive* and *active* systems. The main difference between these two broad systems is in the design of the RFID tags. Passive tags do not have the ability to transmit; they either reflect energy generated by the reader antenna back to the reader or inductively couple to the reader’s communication signal. Active tags, however, have a transmitter as well as a power source (usually a battery) that they use to broadcast a signal containing the information that is stored on the microchip.

### 1.3.1 Passive RFID Systems

Many retailers are eager to use UHF RFID passive tags in the supply chain due to their low cost (between 20 to 40 cents) and low maintenance. As a result of this widespread interest, this thesis will focus on passive UHF RFID systems and the fundamental electromagnetic challenges that surround these systems.

Passive RFID tags do not contain a transmitter or a power source, therefore they

are much slimmer in comparison to active tags that typically require a thick and durable substrate. While passive tags have many benefits over active tags, their main drawback is their shorter read range; passive tags can read between a few inches to 30 feet from a reader antenna.

Passive RFID tags are made up of a microchip and an antenna. The microchip and antenna are usually mounted onto a substrate and placed within a package to create a tag. Most passive tags are used at low, high and ultra high frequencies which generally operate at 125 kHz, 13.56 MHz and between 860 and 960 MHz respectively.

Since waves behave differently at these varying frequencies, each area of the spectrum are used for different applications. While low frequency tags are needed for applications that require identification through materials, high frequency tags are used for applications requiring a longer read range. As the frequency of operation is increased, waves begin to behave more similar to light in that they reflect energy off of and cannot penetrate many materials. Therefore at ultra high frequencies (UHF), the main challenge is reading RFID tags on cases at the center of a pallet as well as on products made of or packaged in highly reflective materials such as metal and water.

### **1.3.2 Active RFID Systems**

The main use of active tags is for large-scale RFID objects such as cargo and large reusable containers, which need to be tracked over long distances. They usually operate at 433MHz, 2.45 GHz, or 5.8 GHz, and typically have a read range between 60 and 300 feet (20 and 100 meters). In addition, active tags can be read more reliably than passive tags as a result of their signal broadcasting to readers. Of course, with these benefits over passive tags, the cost is much higher. Active tags currently range between \$10 and \$100 depending on the amount of memory or information that needs to be stored in the tag's microchip.

Within active tags, there are two main categories: transponders and beacons. Active transponders, such as toll payment collection, are “woken up” when they detect a signal from a reader. For example, tollbooth readers continuously transmit

a signal that will “wake up” the active transponder on a car when it approaches the tollbooth. The transponder then broadcasts its unique ID back to the reader. In this way, transponders are able to conserve battery life by having the tag broadcast its signal only when it is within range of a reader antenna signal.

Beacons are often used when the precise location of an object needs to be tracked and recorded in real-time. A beacon broadcasts a signal with its unique serial number at specific intervals; these intervals can be on the order of seconds or hours depending on the number of locations within a period of time the object needs to be tracked. Using real-time locating systems, the beacon’s signal is recognized by a few different reader antennas that form a perimeter around the area of tracking. These tracking areas, for example distribution yards or large manufacturing facilities, can be expansive, therefore requiring a stronger tag signal as well as longer read ranges that can be obtained with a beacon rather than a transponder or passive tag.

## 1.4 Coupling

Many manufacturers and retailers are eager to use ultra high frequency (UHF) passive systems in their supply chain rather than low and high frequency systems. This is due to the availability of low cost tags as well as increased read range. Tags placed on a pallet going through a portal or dock door can be 10 feet from a reader antenna. Therefore, in order for RFID systems to be useful in the setting of a warehouse, tags need to be able to read from a range of at least 10 feet (3.3 meters).

Low frequency and high frequency tags are practically limited to 12 inches (0.33 meters) and 3 feet (1 meter), respectively, while UHF tags have the ability to read at distances up to 30 feet. This limited read range in low and high frequency bands is a result of many factors, the most important being coupling.

### 1.4.1 Inductive Coupling

Low and high frequency tags use inductive coupling in the near field. This means that an electromagnetic field is formed as a result of the coil in the reader and tag

antennas. A tag harvests power from the field created by the reader antenna to power the microchip. The tag communicates to the reader by changing its electric load on the reader's field. The reader will adjust to this field alteration and collect the specific change in a code that the computer can understand. Since the coils in the reader and tag antennas must together form a magnetic field, the tags must be placed near the reader antenna, therefore limiting the read range of the system.

### **1.4.2 Propagation Coupling**

Passive UHF systems use propagation coupling. Tags gather far field energy from the electromagnetic energy that is emitted by the reader antenna. Using this energy, the tag's microchip changes the load on the tag antenna and reflects a distorted signal back to the reader. This process is known as backscattering.

UHF tags have the ability to communicate binary data with readers in a different ways: increase the amplitude through amplitude shifting, alter the frequency through frequency shifting or shift the wave out of phase through phase shifting. Depending on the type of shifting the tag uses to communicate, the reader picks up the reflected signal and converts the data into the unique serial number of the tag.

## **1.5 Variables That Affect Performance**

The size of the reader antenna field in low and high frequency systems can be easily controlled as a result of inductive coupling. UHF systems are more difficult to control since energy must be transmitted over larger distances. Since waves have a long distance to travel, they can come into contact with surfaces, tags and materials that cause distortions in the field which affect the power that reaches a desired tag.

At low and high frequencies, waves are not reflected off of metals and they are able to penetrate most liquids. Reading tags in a reliable manner is a challenge that is present more in UHF systems than at lower frequencies. This challenge can be attributed to three main factors: antenna detuning, signal attenuation and environmental interference.

### 1.5.1 Antenna Detuning

Since UHF systems use propagation coupling, the tag antenna is tuned to receive waves of a *specific* frequency. When the tag is then placed on an object or product, the tag antenna characteristics can be altered depending on the electromagnetic properties of the product and its packaging. This change in tag antenna characteristics is known as antenna detuning since the tag is able to read on its own but being placed on the product makes it difficult for the tag to receive enough energy to reflect its information back to the reader.

As antennas are tuned to a specific center frequency in *free air*, the center frequency of the antenna can be changed when near different materials. Thus, “reading” this same tag at the original center frequency will not be possible since the tag is now tuned to a substantially different frequency.

Products composed mainly of water along with metallic products cause the most severe antenna detuning. Antenna detuning can be avoided using a few different methods. One method to counter this problem is to create antennas that are in tune in close proximity to either material, water or metal, respectively. Water and metal have reflective properties that, when a tag antenna couples with them, the read range of the tag can be improved. A second method to counter detuning and increase tag performance is to create a gap between the tag and the product since at specific gaps, waves can reflect off of the product to provide more power to the tag.

### 1.5.2 Attenuation

A reduction in the energy received or reflected by the tag in comparison to the reader transmitted energy is known as attenuation. This loss in transmitted energy can be a result of distance, cable loss, external causes or the low power levels at which tags reflect signals back to the reader.

Signal attenuation can be caused by the way that a specific RFID system is configured. As most systems have their reader antennas connected to the reader through coaxial cables, the energy must travel from the reader, through the cable,

to the reader antenna and finally gets transmitted by the reader antenna to the tags in the system. This means that placing reader antennas at great distances from the reader can also decrease system performance.

Liquids and metals can reflect UHF energy, so products composed mainly of water or packaged in a highly reflective material can also attenuate the signal that finally reaches the tags on these objects.

### **1.5.3 Interference**

Electromagnetic interference is mainly caused by noise that results from machinery and neighboring RFID systems. This interference makes it more difficult to generate and receive a clear signal from a UHF tag. Warehouses and other areas where RFID system operate hold many metallic objects that cause electromagnetic reflections in the desired RFID field. Other RF-based systems operating in the vicinity of the RFID system, such as older wireless local area networks, can cause interference since they use the UHF frequency band for operation.

## **1.6 Assumptions and Thesis Overview**

An RFID system is composed of a few key elements: a host, a reader, tags and channels that allow a reader and tags to communicate with one another. In this thesis I concentrate on the power received by the tag along with any components of the system that directly influence this power.

Considering the factors that can affect an RFID systems, there are a few important assumptions that will be made in this thesis. Keeping in mind the regulatory and electromagnetic challenges involved at ultra high frequencies, I will summarize the organization of this thesis based on the fundamental constraints imposed by the specifications of UHF RFID systems.

### 1.6.1 Assumptions

In this thesis, I examine electromagnetic limitations with regards to UHF pallet structures, similar to that of Figure 1.6.1 below. While I have outlined many applications of RFID systems, I assume that all transponders are passive tags. These tags have a range of approximately 6 feet (approximately 2 meters) when interacting with a reader in air. In addition, I assume that there is a single reader through which a signal can be transmitted as well as unique serial numbers that can be collected.



Figure 1-2: Example of a typical warehouse pallet structure.

### 1.6.2 Organization

Ultra high frequencies present many challenges including electromagnetics and communications. These constraints define the means by which tags and readers can perform in RFID systems. In this thesis I outline some of the key limitations as well as suggest possible means to enhance power distribution within certain RFID applications.

In Chapter 2, I discuss the electromagnetic fields and forces that provide the communication link between a reader and a tag. I show how RFID systems achieve power through the coupling involved between reader and tag antennas. This chapter also details near and far-field behavior as it relates to the energy distributed within specific RFID systems. Finally, I examine environmental influences on field and wave characteristics in UHF systems.

In Chapter 3, I examine propagation effects in UHF RFID systems. These effects include reflection, interference and propagation loss. As passive RFID labels are not powered by a battery, they rely on the electromagnetic field for both power and communication. This chapter shows that propagation effects in UHF RFID systems can be explained through fundamental electromagnetic propagation principles.

In Chapter 4, I present the constraints posed on RFID systems as a result of reflection and propagation losses. In this chapter, I introduce the concept of conductive layering within an RFID pallet structure as a means of enhancing the power available in the RFID system. I discuss the key parameters involved in conductive layering as well as show how they are a potential solution to low tag readability in RFID pallets. As there are many variables involved in pallet configurations, three basic setups are presented, compared and contrasted.

In Chapter 5, I examine conductive layering in pallets as a means to increase readability within a pallet structure. By varying a few different key parameters, studies were conducted to determine the effects of energy penetration into the center of a pallet using foil conductive plates. Using a power meter as well as the Auto-ID Labs field probe, the three different pallet configurations presented in Chapter 3 are compared and contrasted under different conditions in order to determine the most efficient pallet structure. The pallet structure that provided the most power to the RFID system used a vertically oriented, linearly polarized reader antenna.

In Chapter 6, I use the results presented in Chapter 4 to study, the RFID system using a vertically oriented, linearly polarized reader antenna, in depth. I present a study that analyzes the pallet structure by varying the conductive properties of the layers, using metal foil and carbon ink. I then examine the influence of these conductive properties on the energy that is penetrated in the pallet, using both foil and conductive carbon ink. These studies showed that conductive ink can provide a similar guiding of power as metal foil at a lower cost. However, as it does not have the same reflective properties of foil, it is not able to channel power to the center of a pallet structure as effectively or provide the same read range.

In Chapter 7, I use the results presented in Chapter 5 to discuss and analyze



practical methods that can be implemented to improve the identification of multiple tags within the range of a reader in an RFID pallet. These practical methods involve the reconfiguration of the pallet structure with packaged items using the concepts of the conductive parallel plates that are suggested in Chapters 3, 4 and 5.

Finally, in Chapter 8, I conclude and present directions for future work.



# Chapter 2

## Electromagnetic Wave Theory

### 2.1 Introduction

In order to fully understand communication between reader and tags, we must first examine the electromagnetic fields and waves that govern the power transfer and communication of passive RFID systems. In this chapter, I present the fundamental concepts of electromagnetics and describe the key parameters that determine the performance of a UHF RFID system.

I first introduce Maxwell's equations to show how these equations describe the behavior of electromagnetic fields at every point in space. Next I describe the parameters that influence the size and shape of the field properties of an antenna. Finally, I discuss propagation through lossy materials and the importance of materials properties on power penetration within a pallet structure.

### 2.2 Maxwell's Equations

Maxwell's equations are a set of equations that describe the fundamentals of electricity and magnetism. The set of four equations govern electromagnetism, i.e. the behavior of electric and magnetic fields as well as their interactions with matter. These equations were first completed by James Clerk Maxwell, who made the addition of the displacement current term to the final set of equations. In three-dimensional vector

notation, the Maxwell equations are:

$$\nabla \times \bar{H}(\bar{r}, t) = \frac{\partial}{\partial t} \bar{D}(\bar{r}, t) + \bar{J}(\bar{r}, t) \quad (2.1)$$

$$\nabla \times \bar{E}(\bar{r}, t) = -\frac{\partial}{\partial t} \bar{B}(\bar{r}, t) \quad (2.2)$$

$$\nabla \cdot \bar{D}(\bar{r}, t) = \rho(\bar{r}, t) \quad (2.3)$$

$$\nabla \cdot \bar{B}(\bar{r}, t) = 0 \quad (2.4)$$

where  $\bar{H}$ ,  $\bar{D}$ ,  $\bar{J}$ ,  $\bar{E}$ ,  $\bar{B}$  and  $\rho$  are real functions of position and time.

$$\bar{H}(\bar{r}, t) = \text{magnetic field strength} \quad (\text{amperes/m})$$

$$\bar{D}(\bar{r}, t) = \text{electric displacement} \quad (\text{coulombs/m}^2)$$

$$\bar{J}(\bar{r}, t) = \text{electric current density} \quad (\text{amperes/m}^2)$$

$$\bar{E}(\bar{r}, t) = \text{electric field strength} \quad (\text{volts/m})$$

$$\bar{B}(\bar{r}, t) = \text{magnetic flux density} \quad (\text{webers/m}^2)$$

$$\rho(\bar{r}, t) = \text{electric charge density} \quad (\text{coulombs/m}^3)$$

Maxwell's four equations express, respectively, Ampère's law, Faraday's law, and Gauss' laws for electric and magnetic fields. Ampère's law, (Equation 2.1), shows how currents produce magnetic fields. Faraday's law, (Equation 2.2), shows how changing magnetic fields produce electric fields. Coulomb's law, or Gauss' law for electric fields, (Equation 2.3), shows how electric charges produce electric fields. And finally, Gauss' law for magnetic fields, (Equation 2.4), shows the experimental absence of magnetic charges.

Maxwell showed that the four equations, predict waves of varying electric and magnetic fields that travel through space at a speed that he obtained through simple electrical experiments. Maxwell obtained a velocity of 310,740,000  $m/s$ . Maxwell (1865) wrote:

*This velocity is so nearly that of light, that it seems we have strong reason to conclude that light itself (including radiant heat, and other radiations if any) is an electromagnetic disturbance in the form of waves propagated through the electromag-*

*netic field according to electromagnetic laws.*[9]

The electric current density,  $\vec{J}(\vec{r}, t)$ , along with the charge density,  $\rho(\vec{r}, t)$ , are related by the following equation:

$$\nabla \times \vec{J}(\vec{r}, t) = -\frac{\partial}{\partial t} \rho(\vec{r}, t) \quad (2.5)$$

Equation 2.5, known as the continuity law, states that the electric current and charge densities at  $\vec{r}$  are conserved. This law, along with Maxwell's equations, form the fundamental equations defining the laws of electromagnetics.

### 2.2.1 Free Space Characterization

While Maxwell's equations are valid at all times for every point in space, in this thesis, there will be an additional focus on the key parameters involved in free-space. Free space is a linear and homogeneous medium where there is no current or electric charge present. Free space is characterized by the following equations:

$$\vec{D} = \epsilon_0 \vec{E} \quad (2.6)$$

$$\vec{B} = \mu_0 \vec{H} \quad (2.7)$$

where

$$\epsilon_0 \approx 8.85 \times 10^{-12} \text{ farad/meter}$$

$$\mu_0 = 4\pi \times 10^{-7} \text{ henry/meter}$$

where  $\epsilon_0$  is the permittivity of free space and  $\mu_0$  is the permeability of free space.

### 2.2.2 Wave Equation and Solution

The fundamental equations of electromagnetics model the behavior of electromagnetic fields in all media. In regions where  $\vec{J} = 0$  and  $\rho = 0$ , i.e. source-free regions in free space, Maxwell's equations are simplified to

$$\nabla \times \bar{H} = \epsilon_0 \frac{\partial \bar{E}}{\partial t} \quad (2.8)$$

$$\nabla \times \bar{E} = -\mu_0 \frac{\partial \bar{H}}{\partial t} \quad (2.9)$$

$$\nabla \cdot \bar{E} = 0 \quad (2.10)$$

$$\nabla \cdot \bar{H} = 0 \quad (2.11)$$

After breaking these down in the form of scalar partial differentials, and eliminating  $\bar{H}$ , we obtain

$$\nabla^2 \bar{E} - \mu_0 \epsilon_0 \frac{\partial^2 \bar{E}}{\partial t^2} = 0 \quad (2.12)$$

which is known as the Helmholtz wave equation.

Solutions to the wave equation, (Equation 2.12), are called electromagnetic waves where

$$k^2 = \omega^2 \mu_0 \epsilon_0 \quad (2.13)$$

known as the dispersion relation, holds. Since the electric and magnetic fields,  $\bar{E}(\bar{r}, t)$  and  $\bar{H}(\bar{r}, t)$ , respectively, both vary according to space and time, the dispersion relation, (Equation 2.13), provides the connection between the temporal frequency,  $\omega$ , and the spacial frequency,  $k$ . While the spatial view point examines spatial variation at given fixed points in time, the temporal view point examines the time at fixed locations in space. It is important to also note that  $c = \sqrt{\mu_0 \epsilon_0}$ , where,  $c = 3 \times 10^8 (m/s)$ , is the speed of light in a vacuum. This relation provides a means of relating spatial frequency to the wavelength, given by

$$k = \omega \sqrt{\mu_0 \epsilon_0} = \frac{\omega}{c} = \frac{2\pi}{\lambda_0}. \quad (2.14)$$

### 2.2.3 Poynting's Theorem and Time-Average Power Vector

In order to investigate power and energy conservation from Maxwell's equations, Ampère's law, Equation 2.1, and Faraday's law, Equation 2.2, must be manipulated and compared. When Ampère's law is dot-multiplied by  $\bar{E}$  and Faraday's law is dot-multiplied by  $\bar{H}$ , the difference between these two new equations can allow power density to be examined. Using the vector identity  $\nabla \cdot (\bar{E} \times \bar{H}) = \bar{H} \cdot \nabla \times \bar{E} - \bar{E} \cdot \nabla \times \bar{H}$  we are finally left with

$$\nabla \cdot (\bar{E} \times \bar{H}) + \bar{H} \cdot \frac{\partial \bar{B}}{\partial t} + \bar{E} \cdot \frac{\partial \bar{D}}{\partial t} = -\bar{E} \cdot \bar{J} \quad (2.15)$$

more commonly known as Poynting's theorem. The Poynting vector

$$\bar{S}(\bar{r}, t) = \bar{E}(\bar{r}, t) \times \bar{H}(\bar{r}, t) \quad (2.16)$$

is a measure of the power flow density and has the units of watts/m<sup>2</sup>. While, the Poynting vector is a real vector that can show the measure of power density, it is difficult to calculate as it carries a time dependence. In order to eliminate this time dependence the time average power,  $\langle \bar{S}(\bar{r}, t) \rangle$  can be calculated

$$\begin{aligned} \langle \bar{S}(\bar{r}, t) \rangle &= \frac{1}{2\pi} \int_0^{2\pi} d(\omega t) \bar{S}(\bar{r}, t) \\ &= \frac{1}{2} [\bar{E}_R \times \bar{H}_R + \bar{E}_I \times \bar{H}_I] \\ &= \frac{1}{2} \text{Re}\{\bar{S}(\bar{r})\} \end{aligned} \quad (2.17)$$

Therefore when the complex Poynting vector,  $\bar{S} = \bar{E} \times \bar{H}^*$ , is known, halving its real part will result in the time average value

$$\langle \bar{E} \times \bar{H} \rangle = \frac{1}{2} \text{Re}\{\bar{E} \times \bar{H}^*\}. \quad (2.18)$$

## 2.3 Antennas

In the simplest terms, an antenna is a component in an electrical system that is designed to transmit or receive radio waves. Maxwell's equations describe the behavior of electromagnetic waves and fields. Using Maxwell's equations, this section also details how antennas are able to produce these fields as well as describe the basic characteristics of an electrically small antenna, the Hertzian dipole.

There are a few key variables that determine the performance of an antenna. These variables can be adjusted during the design process for the purposes of the specific design application. They include impedance, resonant frequency, radiation pattern, gain, polarization, bandwidth and efficiency and are expanded upon in this section.

### 2.3.1 Hertzian Waves and the Hertzian Dipole

A Hertzian dipole describes a pair of electric charges of equal magnitude but opposite polarity,  $\pm q$ , separated by an infinitesimally small distance,  $\ell$  of a thickness  $a$ . In addition to being very small,  $\ell \ll \lambda$ , the wire is also very thin,  $a \ll \lambda$ . Although infinitesimal dipoles are not practical, I chose to present them as they are used as the building block of more complex antenna structures and geometries.

Dipoles are defined by their dipole moment,  $p$ , a vector quantity with a magnitude equal to the product of the charge of the poles and the distance separating the two poles or  $p = q\ell$ . Hertz solved for the electromagnetic fields assuming that the two charges were placed at  $z = \pm\ell/2$  as shown below in Figure 2.3.1.

Hertz derived the electric and magnetic field vectors in the spherical coordinate system as shown above in Figure 2.3.1. The unit vectors associated with the spherical coordinate system above are as follows

$$\hat{r} = \hat{x} \sin \theta \cos \phi + \hat{y} \sin \theta \sin \phi + \hat{z} \cos \theta \quad (2.19)$$

$$\hat{\theta} = \hat{x} \cos \theta \cos \phi + \hat{y} \cos \theta \sin \phi - \hat{z} \sin \theta \quad (2.20)$$



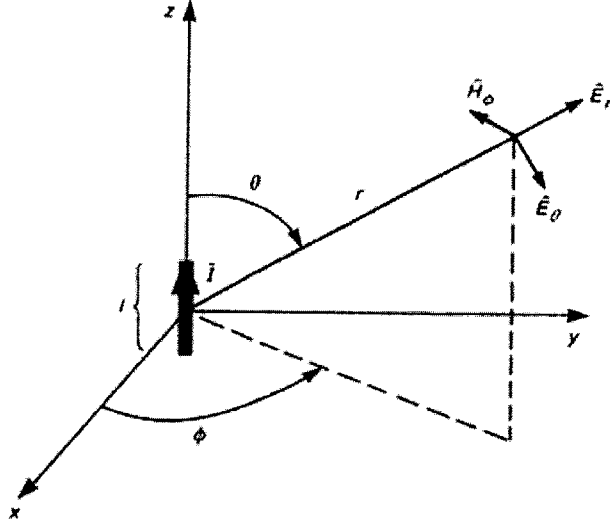

Figure 2-1: Geometric arrangement of an infinitesimal dipole and its associated field components.

$$\hat{\phi} = -\hat{x} \sin \phi + \hat{y} \cos \phi \quad (2.21)$$

Using the position vector  $\vec{r} = \hat{r}r = \hat{x}x + \hat{y}y + \hat{z}z$ , it can be seen that  $x = \hat{x} \cdot \vec{r} = r \sin \theta \cos \phi$ ,  $y = r \sin \theta \sin \phi$ , and  $z = r \cos \theta$ . The resulting magnetic and electric fields are found to be

$$\vec{H} = \hat{\phi} \frac{\omega k q \ell}{4\pi r} \sin \theta \left[ \frac{1}{kr} \sin(kr - \omega t) - \cos(kr - \omega t) \right] \quad (2.22)$$

$$\vec{E} = \frac{k^2 q \ell}{4\pi \epsilon_0 r} \left\{ (\hat{\theta} \sin \theta + \hat{r} 2 \cos \theta) \left[ \frac{1}{k^2 r^2} \cos(kr - \omega t) + \frac{1}{kr} \sin(kr - \omega t) \right] - \hat{\theta} \sin \theta \cos(kr - \omega t) \right\}. \quad (2.23)$$

### 2.3.2 Special Cases

These solutions to the magnetic and electric field are a closed form analytical expression valid for all distances  $\hat{r}$  from the dipole antenna. In addition to this general expression, there are a few special cases that should be considered.

### Case 1: The $\hat{z}$ Direction

Along the  $z$ -axis,  $\theta = 0$  or  $\pi$ , therefore there is no magnetic field and the resulting electric field vector is only in the  $\hat{z}$  direction and is given by

$$\bar{E} = \hat{z} \frac{kq\ell}{2\pi\epsilon_0 r^2} \left[ \frac{1}{kr} \cos(kr - \omega t) + \sin(kr - \omega t) \right].$$

### Case 2: The $x - y$ Plane

When  $\theta = \pi/2$ , in the  $x - y$  plane, the field vectors are given by

$$\begin{aligned} \bar{H} &= \hat{\phi} \frac{\omega k q \ell}{4\pi\epsilon_0 r} \left[ -\cos(kr - \omega t) + \frac{1}{kr} \sin(kr - \omega t) \right] \\ \bar{E} &= \hat{\theta} \frac{k^2 q \ell}{4\pi\epsilon_0 r} \left[ \left( -1 + \frac{1}{k^2 r^2} \cos(kr - \omega t) \right) + \frac{1}{kr} \sin(kr - \omega t) \right] \end{aligned}$$

where the electric field is always perpendicular to the  $x - y$  plane, that is  $\hat{\theta} = -\hat{z}$ .

### Case 3: The Near Field

When,  $kr \rightarrow 0$ , that is in the area immediately around the dipole, terms of the order of  $1/r^2$  and  $1/r^3$  will influence the magnetic and electric field vectors. This region is known as the near field of the antenna. The field vectors are

$$\bar{H} = -\hat{\phi} \frac{\omega q \ell}{4\pi r^2} \sin \theta \sin \omega t \quad (2.24)$$

$$= \hat{\phi} \frac{I \ell}{4\pi r^2} \sin \theta \quad (2.25)$$

$$\bar{E} = \frac{q \ell}{4\pi\epsilon_0 r^3} (\hat{r} 2 \cos \theta + \hat{\theta} \sin \theta) \cos \omega t. \quad (2.26)$$

#### Case 4: The Far Field

When  $kr \gg 1$ , or at large distances away from the antenna, terms of the order of  $1/r^2$  and  $1/r^3$  are negligible. The field vectors at these locations are

$$\bar{H} = -\hat{\phi} \frac{\omega k q \ell}{4\pi r} \sin \theta \cos(kr - \omega t) \quad (2.27)$$

$$\bar{E} = -\hat{\theta} \frac{k^2 q \ell}{4\pi \epsilon_0 r} \sin \theta \cos(kr - \omega t). \quad (2.28)$$

#### Case 5: Power in the Far Field

As we are most concerned with the fields at distances where  $kr \gg 1$ , the far field, the last case studies the power and energy seen at large distances from the antenna.

$$\bar{S} = \bar{E} \times \bar{H} = \hat{r} \frac{1}{2} \frac{\omega k^3}{\epsilon_0} \left( \frac{q \ell}{4\pi r} \right)^2 \sin^2 \theta \cos^2(kr - \omega t) \quad (2.29)$$

which is Poynting's power density vector at a very great distance. The time-average power density is

$$\langle \bar{S} \rangle = \frac{1}{2\pi} \int_0^{2\pi} d(\omega t) \bar{E} \times \bar{H} = \hat{r} \frac{1}{2} \frac{\omega k^3}{\epsilon_0} \left( \frac{q \ell}{4\pi r} \right)^2 \sin^2 \theta. \quad (2.30)$$

This radiation pattern is shown below in Figure 2.3.2.

### 2.3.3 Impedance and Efficiency

Impedance, as a general term in electrical engineering, is a measure for the extent to which a component resists the flow of electrical current when a voltage is applied to it. Impedance differs from resistance in that it also takes into account a phase offset. In electromagnetic wave theory, the impedance,  $Z$ , in the transmitted region is

$$Z = \frac{\bar{E}(\bar{r}, t)}{\bar{H}(\bar{r}, t)} \quad (2.31)$$

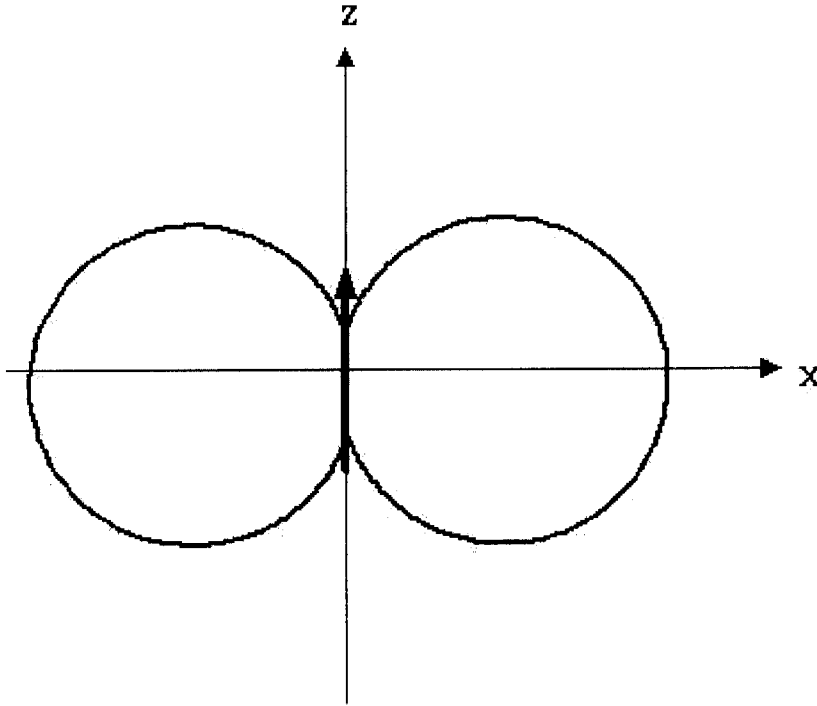

Figure 2-2: Radiation power pattern of a dipole.

where  $Z$  is determined by the ratio of the electric field to the magnetic field and is treated in a similar way to a refractive index.

Efficiency is a measure of the ratio of power actually radiated to the power put into the antenna terminals. The relationship with the refractive index is a result of different components of an RFID system (antenna, free space, tag, product) having different impedances. At each interface between parts of the system a fraction of the wave's energy will reflect back to the source. Therefore, minimizing differences in impedance at each interface will maximize power transfer, and therefore efficiency, through each part of the antenna system.

### 2.3.4 Resonant Frequency and Bandwidth

Most antennas are designed for a specific frequency and are effective for a range of frequencies that are centered around the resonant frequency. However, other properties of an antenna, can change drastically with frequency; therefore, an antenna's

resonant frequency may sometimes only be *close* to the center frequency of these other more integral antenna properties, namely radiation pattern and impedance.

The bandwidth of an antenna is the range of frequencies over which it is effective, usually centered around the resonant frequency. Antennas can be made to resonate over multiple frequencies or over a very broad range of frequencies. However, this can severely decrease the gain of the antenna in comparison with a comparable narrow-band antenna.

### **2.3.5 Radiation Pattern**

The radiation pattern describes the variation in the electromagnetic field intensity of an antenna as a function of position or angle with respect to the axis of the antenna. This variation is usually represented for both the far-field and near field conditions. The near field radiation pattern describes the radiant emittance in  $W/m^2$  as a function of position in the plane of the antenna. The far field radiation pattern describes the irradiance as a function of angle in the far field region of the antenna.

### **2.3.6 Gain**

Gain is a one-dimensional measure comparing an antenna to either an isotropic antenna which is an antenna that radiates equally in all directions or a dipole antenna. The dipole is used as a practical reference since an isotropic source cannot be realized in practice. Dipoles have a 2.1 dB gain over an isotropic source. Most practical antennas radiate more than the isotropic antenna in some directions and less in others as practical antennas have an uneven distribution of power. The gain of an antenna is usually measured in the direction which an antenna radiates best. Unless otherwise specified, this thesis will refer to the gain of an antenna relative to an isotropic radiator.

### **2.3.7 Polarization**

The polarization of an antenna is the polarization of the signals it emits. In RFID systems, it can make a tremendous difference in signal quality to have the transmitter (reader antenna) and receiver (tag) using the same polarization. Polarizations commonly considered are linear (vertical and horizontal) and circular, which is divided into right-hand and left-hand circular. These divisions of antenna polarization will be further discussed in the later chapters of this thesis.

## **2.4 Sources of Attenuation**

Much of this chapter focuses on electromagnetic fields and waves in free space. As free space is a uniform, non-absorbing media, there are no interferences with transmission and reception. In real RFID systems, however, there are objects that surround and interfere with transmitted signals. Therefore electromagnetic fields and waves in RFID systems will differ from those in free space. There are a few properties of media that are particularly important in propagation through media. A few of these properties are discussed briefly in this section and in further detail in Chapter 3.

### **2.4.1 Antennas in the Field**

Coupling between tag antennas can adversely affect the transfer of power when multiple tags are within close range of one another. Tags located in close proximity can detune neighboring antennas in the near field. In the far field, however, the radiation patterns can be drastically distorted by tags in close proximity to one another. This in turn reduces the efficiency of power transfer within the RFID system.

### **2.4.2 Temperature and Environmental Influences**

Temperature changes can result in mismatching circuitry that cause reduced efficiency as well as a shift in the resonant frequency. In addition, humidity can also adversely affect the performance of an RFID system. As these effects are generally more relevant

when operating at frequencies above the UHF frequency range, I will not focus on temperature and environmental influences in this thesis.

## 2.5 Summary

In this chapter, I present the sources of power in RFID systems through electromagnetic fields and waves. Using the electromagnetic fields created by an antenna, I show the characteristics of near-field and far-field radiation. In addition, I introduce the sources of energy as they relate to these particular field regions. Finally, I analyze the main sources of power loss and the influences of surroundings on the characteristics of waves in RFID systems. In the next chapter, I discuss in further detail the sources of power loss within RFID systems. I then introduce the concept of conductive layering within an RFID pallet structure and discuss the key parameters involved in this type of layering.





# Chapter 3

## Study of Wave Propagation

### 3.1 Introduction

RFID tags perform differently according to environmental, material and electromagnetic conditions. There are different physical mechanisms that are involved in the propagation of electromagnetic waves through a box of material; these mechanisms include reflections/scattering, absorption, and spreading loss. As a result of these mechanisms, the signal that reaches a tag placed on the opposite side of a case as the reader antenna is far weaker than the original reader transmitted signal. This is due mainly to the characteristics of the objects that precede the tag. This chapter outlines the fundamental electromagnetic issues that affect the performance of RFID systems.

### 3.2 Electromagnetic Propagation

The total propagation loss, as shown in Figure 3.2 below, of an RFID system contains several key elements: reflection loss due to media boundaries, attenuation loss as a result of lossy media and spreading loss due to the radiating properties of antennas as was shown in Chapter 2.

Each of these factors can be analyzed based on the material properties and boundary conditions.[6]

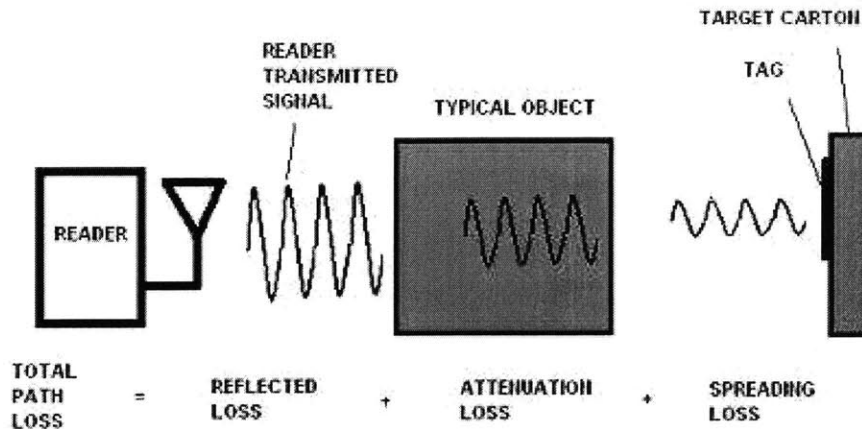

Figure 3-1: Electromagnetic penetration to the center of a pallet.

### 3.3 Theoretical Measurements

While RFID communication has improved significantly over the past five years, tags continue to be extremely sensitive to their environment. To demonstrate the interference and propagation loss through materials, I investigated the electromagnetic field produced by an RFID reader through a variable depth of product.

The theoretical transmission coefficients for these materials is shown in Figure 3.3. As can be seen in the figure, the theoretical transmission coefficient using three different conductivities exhibit similar periodic shapes.

### 3.4 Experimental Measurements

The experiment uses a UHF RFID Reader, with a linearly polarized reader antenna, an Auto-ID tag emulator and a commercial tag, as shown in Figure 3.4. As many commercial products contain water or have material characteristics to water, water was chosen as a test material.

The received power was measured at three separate frequencies;  $903MHz$ ,  $915MHz$  and  $917MHz$ , using both the tag emulator and the RFID tag. In this experiment,  $H = 40cm$  and  $T = 100cm$ , therefore the only varying parameter was  $D$ , which was

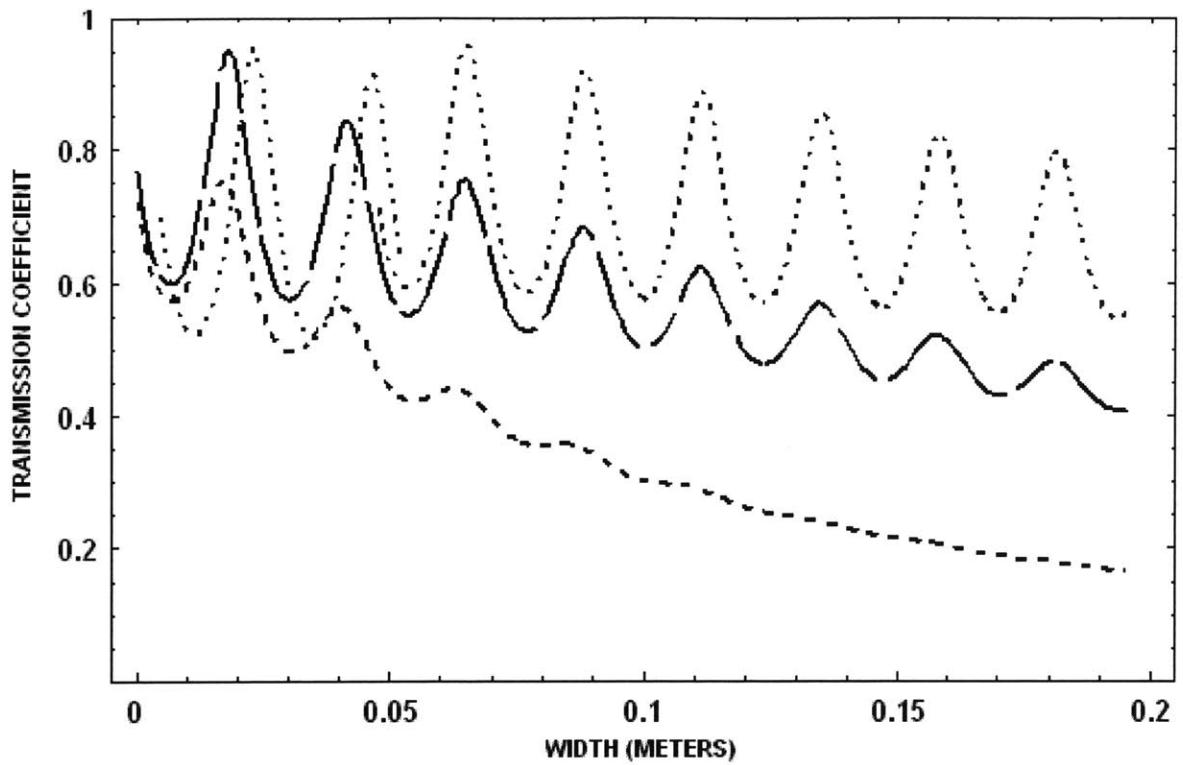

Figure 3-2: Plot of computed transmission coefficient for water as a function of thickness.

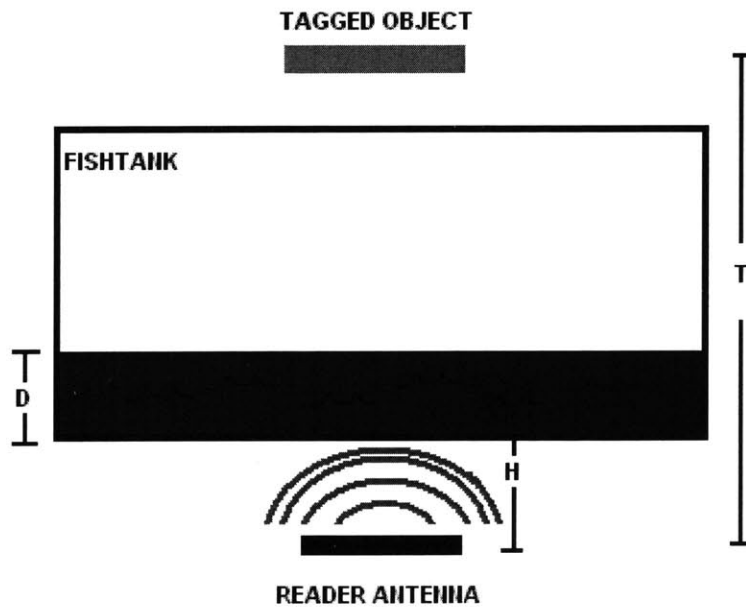

Figure 3-3: Illustration of setup used for measurements.

incremented, one centimeter at a time from 0 to 18cm.

### 3.5 Experimental Results

Using the tag emulator, the detected power was maximum without water present and decreased periodically when  $D$  was increased. The period of this power decrease was approximately 2cm, as shown in Figure 3.5 for each of the three frequencies. This agrees with the half-wavelength behavior exhibited in the theoretical measurements in Figure 3.3.

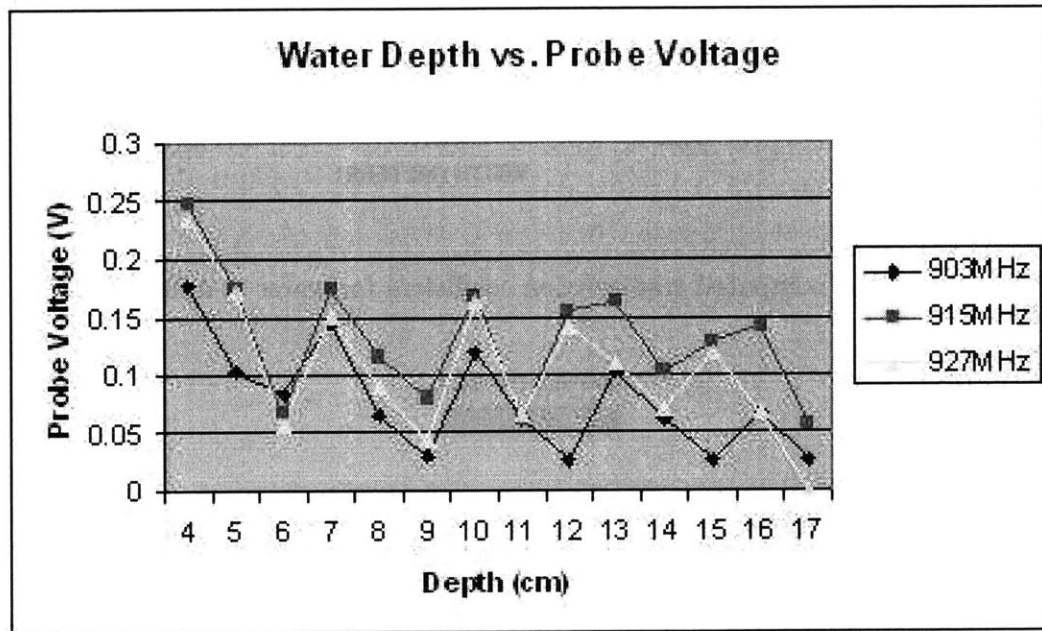

Figure 3-4: Measured results using a field probe.

In order to apply the relevance of these measurements to real UHF RFID systems, the same experiment was conducted using a commercial RFID label instead of the tag emulator. While the tag does not provide the same accuracy of field strength measurements as the emulator, the power received by the tag was measured by the number of successful identifications occurred in one minute as shown in Figure 3.5.

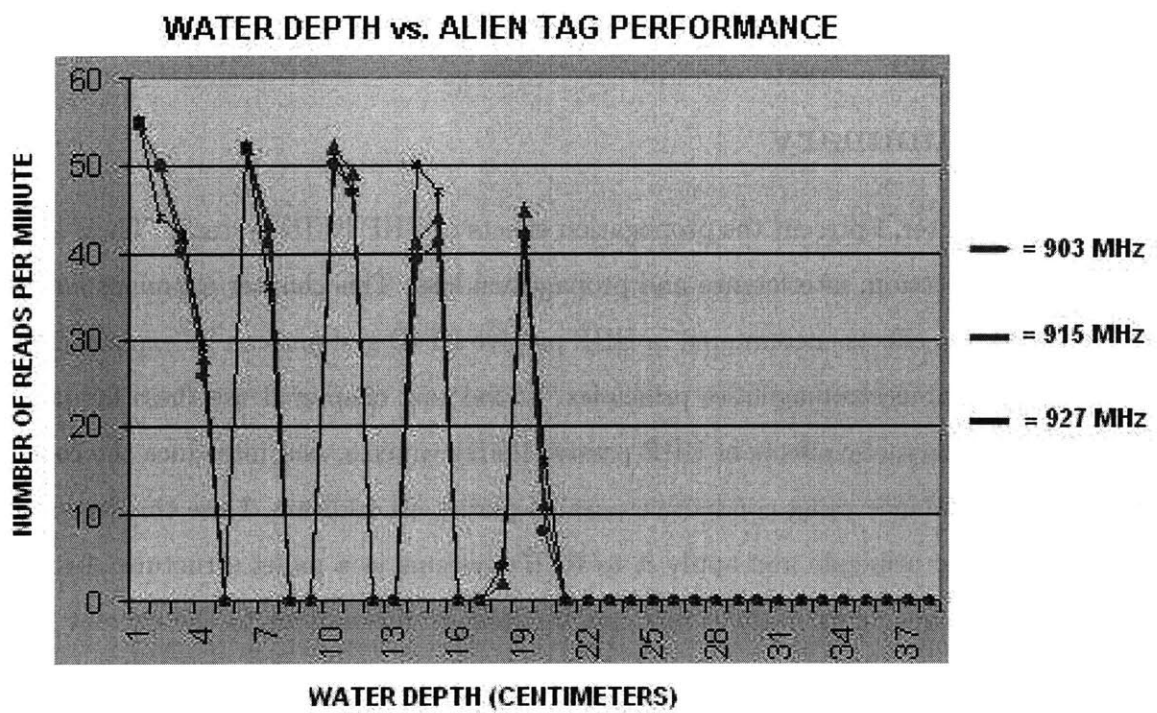

Figure 3-5: Measured results using an RFID tag.

## 3.6 Experiment Discussion

Using fundamental electromagnetic propagation calculations, the propagation effects in commercial RFID systems can be evaluated. The most interesting finding of this experiment shows that reflection and interference play the most critical role in RFID propagation loss rather than absorption losses. In addition, the results show that the thickness of a specific material influences whether the power reaching a tag is maximum or minimum. These specific depths are dependent on variables such as permeability, permittivity and frequency of operation and vary with a period  $\lambda/2$ .

## 3.7 Summary

In this chapter, I present the propagation effects of UHF RFID systems. These effects include reflection, interference and propagation loss. This chapter examines how the propagation effects encountered in UHF passive RFID systems can be explained from fundamental electromagnetics principles. In the next chapter, I use these fundamental electromagnetic effects of UHF passive RFID systems, and introduce the concept of wave guidance using conductive parallel-plates. In addition, I use this basic electromagnetic principle and apply it to RFID systems in a pallet structure. I discuss three different configurations that can be used as alternatives to the current pallet structure.

# Chapter 4

## Wave Guidance

### 4.1 Introduction

Parallel plate waveguides are often used in scattering and antenna problems. In physics, optics, and telecommunication, a waveguide is an inhomogeneous material medium that confines and guides a propagating electromagnetic wave as shown in Figure 4.1, below. Waveguide propagation modes depend on the operating wavelength, polarization as well as the shape and size of the guide.

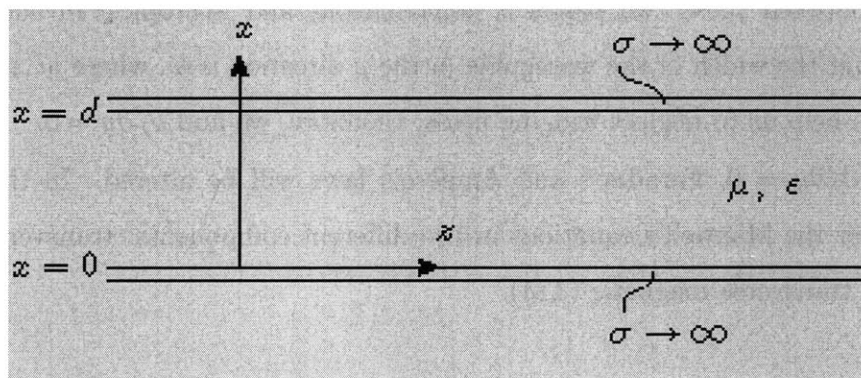

Figure 4-1: Parallel-plate waveguide.

An electromagnetic wave can propagate along a waveguide in a few ways. The two most common modes are known as transverse electric ( $TE$ ) and transverse magnetic ( $TM$ ). When propagating along the  $TE$  mode, the electric lines of flux are perpen-

dicular to the axis of the waveguide. While, when propagating along the TM mode, the magnetic lines of flux are perpendicular to the axis of the waveguide. As long as the interior of the waveguide is free of environmental influences such as moisture and dust, either of these modes can provide high efficiency and low loss to the system.

In order for a waveguide to be effective, it must have a specific minimum diameter that is related to the wavelength of the signal. If the waveguide is too narrow or the wavelength is too long (the frequency is too low), the electromagnetic fields will not be able to propagate. Based on the dimensions of the waveguide, there exists a cutoff frequency. This is the lowest frequency at which the waveguide is large enough. Essentially, any frequency above the cutoff frequency will propagate effectively through the waveguide, however, certain characteristics vary depending on the number of wavelengths in the cross section exist.

## 4.2 Modes of Propagation

First, we consider the guidance of electromagnetic waves through a set of perfectly conductive plates located at  $x = 0$  and  $x = d$ , respectively. We assume that the medium between these two plates is homogeneous and isotropic. In addition, we assume that the width of the waveguide in the  $y$  direction is  $w$ , where  $w \gg d$ . These conditions help us to neglect fringing fields, therefore, we find  $\partial/\partial y = 0$ .

Since  $\partial/\partial y = 0$ , Faraday's and Ampère's laws will be altered. In this section we consider the Maxwell's equations in two different components: transverse electric (TE) and transverse magnetic (TM).

### 4.2.1 TE Modes

The set of Maxwell's equations governing TE waves are as follows:

$$\left( \frac{\partial^2}{\partial x^2} + \frac{\partial^2}{\partial y^2} - \mu\epsilon \frac{\partial^2}{\partial t^2} \right) E_y = 0 \quad (4.1)$$



$$\mu \frac{\partial}{\partial t} H_x = \frac{\partial}{\partial z} E_y \quad (4.2)$$

$$\mu \frac{\partial}{\partial t} H_z = -\frac{\partial}{\partial x} E_y. \quad (4.3)$$

### 4.2.2 TM Modes

The set of Maxwell's equations governing TM waves are as follows:

$$\left( \frac{\partial^2}{\partial x^2} + \frac{\partial^2}{\partial y^2} - \mu\epsilon \frac{\partial^2}{\partial t^2} \right) H_y = 0 \quad (4.4)$$

$$\epsilon \frac{\partial}{\partial t} E_x = \frac{\partial}{\partial z} H_y \quad (4.5)$$

$$\epsilon \frac{\partial}{\partial t} E_z = -\frac{\partial}{\partial x} H_y. \quad (4.6)$$

## 4.3 TE Field Components in the Waveguide

In the parallel-plate waveguide, the wave is guided in the  $\pm\hat{z}$  direction. The boundary conditions at these plates require that the electric field be zero when  $x = 0, d$ . Therefore, we find that for waves propagating in the  $+\hat{z}$  direction, the TE solution is given by

$$E_y = (A \cos k_x x + B \sin k_x x) \cos(k_z z - \omega t) \quad (4.7)$$

When Equation 4.7 is substituted into Equation 4.1, we are left with the dispersion relation

$$k_z^2 + k_x^2 = \omega^2 \mu\epsilon = k^2 \quad (4.8)$$

The boundary conditions demand that  $E_y = 0$  when  $x = 0, d$ , making  $A = 0$  from which we obtain the guidance condition

$$k_x d = m\pi \quad (4.9)$$

Therefore, we can finally write the field components in the parallel-plate waveguide

$$E_y = B \sin k_x x \cos(k_z z - \omega t) \quad (4.10)$$

$$H_x = -\frac{k_z}{\omega\mu} B \sin k_x x \cos(k_z z - \omega t) \quad (4.11)$$

$$H_z = \frac{k_x}{\omega\mu} B \cos k_x x \sin(k_z z - \omega t). \quad (4.12)$$

## 4.4 TM Field Components in the Waveguide

In the parallel-plate waveguide, the wave is guided in the  $\pm\hat{z}$  direction. The boundary conditions at these plates require that the electric field be zero when  $x = 0, d$ . Therefore, we find that for waves propagating in the  $+\hat{z}$  direction, the TM solution is given by

$$H_y = (A \cos k_x x + B \sin k_x x) \cos(k_z z - \omega t) \quad (4.13)$$

When Equation 4.13 is substituted into Equation 4.4, we are left with the dispersion relation, as shown above in Equation 4.8. In a similar manner, we can obtain the electric field components using Equations 4.5 and 4.6.

$$E_x = \frac{k_z}{\omega\epsilon} (A \cos k_x x + B \sin k_x x) \cos(k_z z - \omega t) \quad (4.14)$$

$$E_z = -\frac{k_x}{\omega\epsilon} (A \sin k_x x - B \cos k_x x) \sin(k_z z - \omega t) \quad (4.15)$$

Given that  $E_z = 0$  when  $x = 0, d$ , we find that  $B = 0$ , therefore giving the guidance condition as was obtained above in Equation 4.9. Therefore, we can finally write the field components in the parallel-plate waveguide

$$H_y = A \cos k_x x \cos(k_z z - \omega t) \quad (4.16)$$

$$E_x = \frac{k_z}{\omega\epsilon} A \cos k_x x \cos(k_z z - \omega t) \quad (4.17)$$

$$E_z = -\frac{k_x}{\omega\epsilon} A \sin k_x x \sin(k_z z - \omega t) \quad (4.18)$$

The guidance condition, as represented in Equation 4.9, indicates that in order for the bouncing waves in the  $\hat{x}$  direction to be guided, they must interfere constructively with  $2k_x d = 2m\pi$ . Therefore the values of  $k_x$  that will be guided are given by

$$k_x = \frac{m\pi}{d} \quad (4.19)$$

where  $m$  is an integer.

## 4.5 Cutoff Frequency

The spatial frequency at which  $k_z = 0$  is known as the cutoff frequency  $k_{cm}$ . This frequency is obtained when the guidance condition, Equation 4.9 is substituted into the dispersion relation, Equation 4.8. With this substitution we obtain

$$k_z^2 + k_{cm}^2 = k^2 \quad (4.20)$$

where

$$k_{cm} = \frac{m\pi}{d} \quad (4.21)$$

It can be seen from Equations 4.20 and 4.21, that as  $k < k_{cm}$ ,  $k_z$  will become imaginary, that is,  $k_z = ik_{zI}$ . This in turn means that the guided wave will attenuate in the  $\hat{z}$  direction. The time-average power in the  $\hat{z}$  direction is zero, therefore, the guided modes when  $k < k_{cm}$  are evanescent. Thus, it can be seen that the waves inside the waveguide will propagate at modes where  $k > k_{cm}$ .

One important difference between the TE and TM waves is that there is no TE<sub>0</sub> mode. The lowest-order TE mode is TE<sub>1</sub>.

## 4.6 Power Density

Since the Poynting power density is given by,  $\bar{S} = \bar{E} \times \bar{H}$ , for TE waves it follows that

$$\bar{S} = -\hat{z}E_yH_x + \hat{x}E_yH_z \quad (4.22)$$

Therefore, the time-average Poynting power density is given by

$$\langle \bar{S} \rangle = \hat{z} \frac{k_z}{2\omega\mu} B^2 \sin^2 k_x x. \quad (4.23)$$

## 4.7 Conductive Layering in RFID Systems

It is conventional practice in the RFID industry to transport groups of cases in large stacks called pallets as shown below in Figure 4.7. The composition of pallets may vary widely depending on the product; however, most pallets are comprised of several layers of smaller case boxes built atop a wooden or plastic skid (also sometimes called a pallet).

Electronic tagging of pallets is generally done in two ways: tagging of the pallet itself and tagging of the individual cases. Since it is not always technically possible to successfully read all the case tags on a pallet, a common practice in the industry is to associate the contents of the entire pallet with the single pallet tag. This is known as aggregation.

In this thesis, I focus on improving identification of each individual case on the pallet as its own unit, as shown above in Figure 4.7. The tagging of pallets is a challenging problem since we still encounter the same mechanisms as with a single case. However, in tagging of a pallet, these mechanisms are compounded as a result of multiple cases and tags requiring identification.

Keeping in mind the fundamental electromagnetic issues that affect the performance of these more complex RFID systems, the concept of wave guidance using parallel-plates is used to improve tag identification on individual cases in a pallet

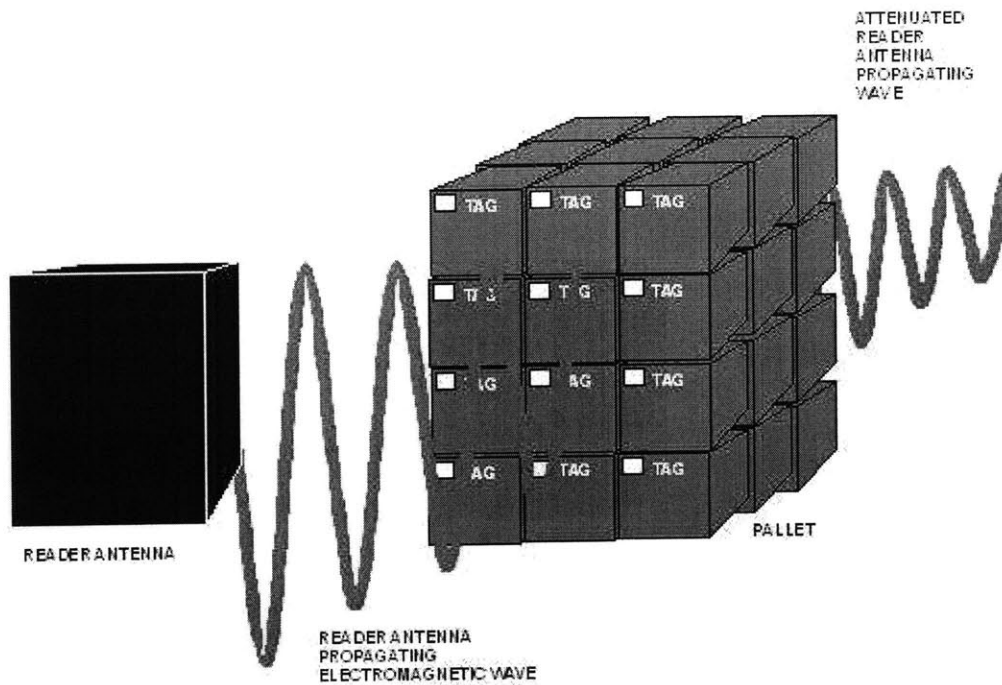

Figure 4-2: Tagging of individual cases on a pallet.

structure. As there are numerous different parameters that are involved in UHF RFID systems, I chose three different pallet structure to study, compare and contrast.

#### 4.7.1 Proposed Pallet Structures

##### Structure 1

The first structure uses a vertically oriented, linearly polarized reader antenna as shown below in Figure 4.7.1, below.

##### Structure 2

The second structure uses a horizontally oriented, linearly polarized reader antenna as shown below in Figure 4.7.1, below.

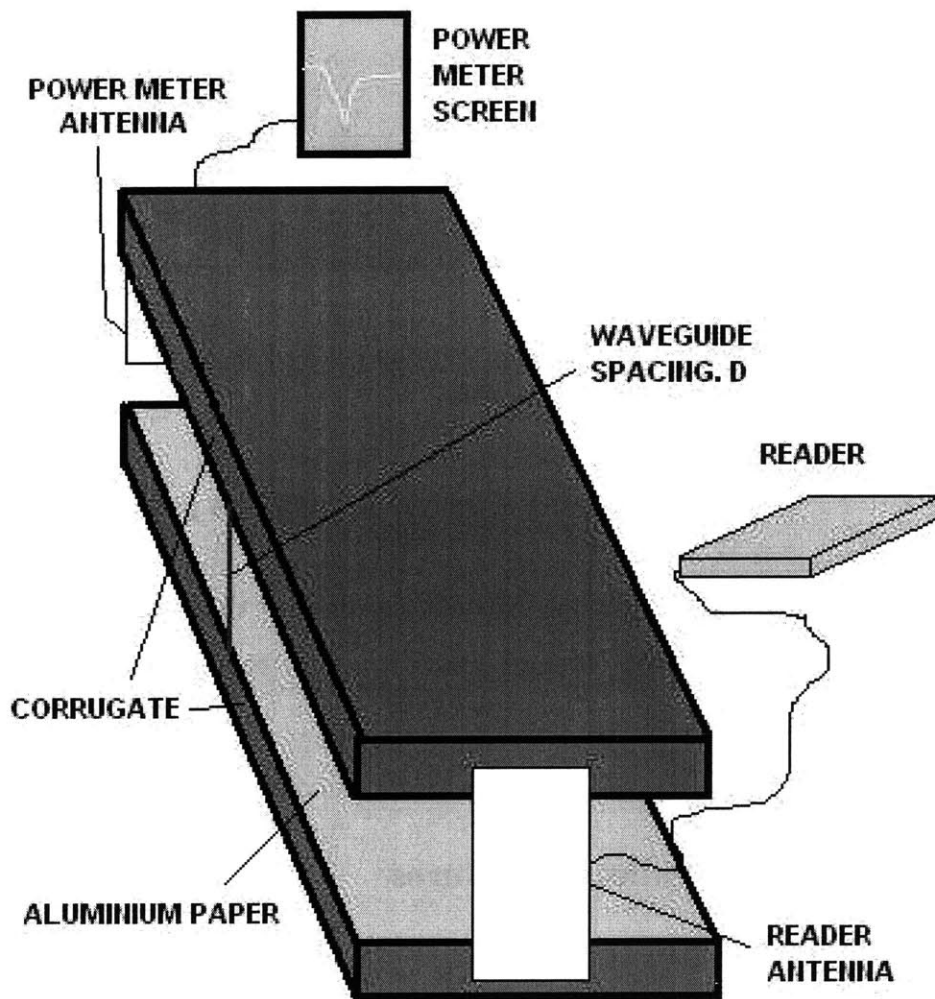

Figure 4-3: Structure 1: Vertically oriented, linearly polarized reader antenna.

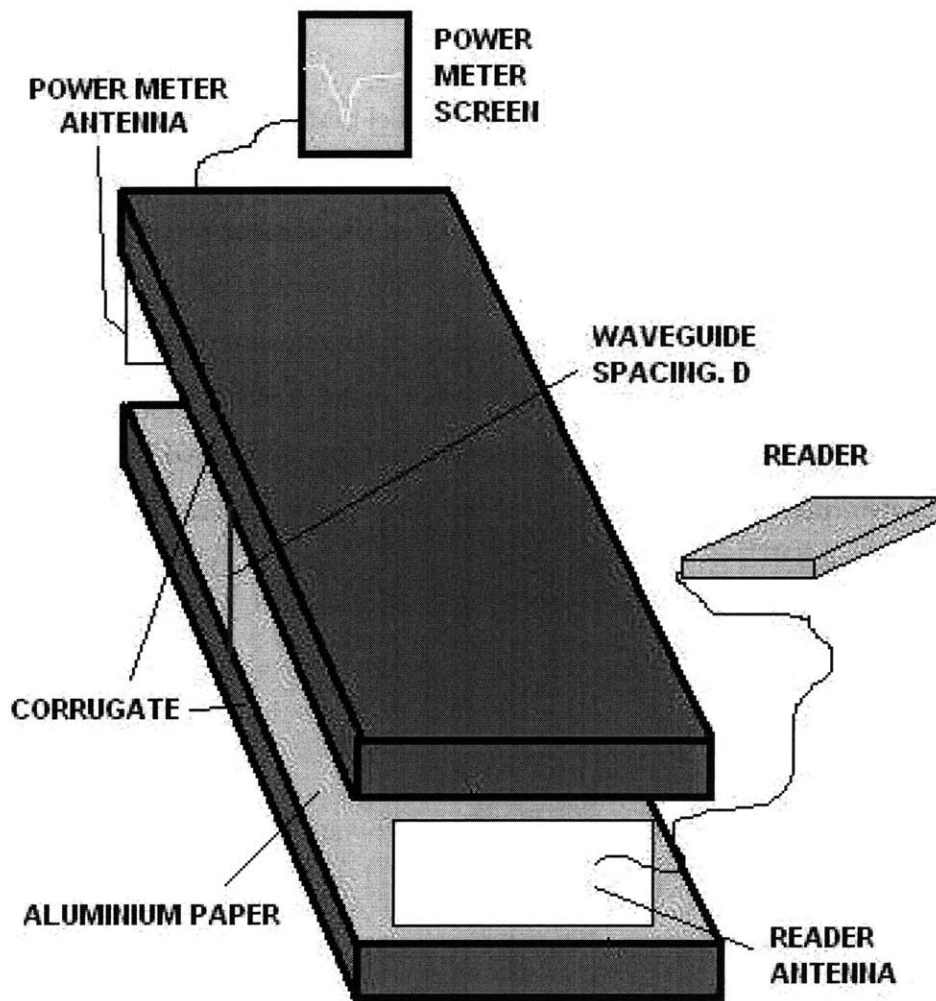

Figure 4-4: Structure 2: Horizontally oriented, linearly polarized reader antenna.

### Structure 3

The third structure uses a circularly polarized reader antenna as shown below in Figure 4.7.1, below.

## 4.8 Summary

In this chapter, I present the concept of parallel-plate waveguides as they apply to RFID systems. Keeping the fundamental electromagnetic effects of UHF passive RFID systems in mind, this chapter introduces the concept of wave guidance using conductive parallel-plates. In addition, I use this basic electromagnetic principle and apply it to RFID systems in a pallet structure. I discuss three different configurations that can be used as alternatives to the current pallet structure. In the next chapter, I analyze, in detail, the differences between these three proposed pallet structures in order to determine the most efficient of the three pallet structures.



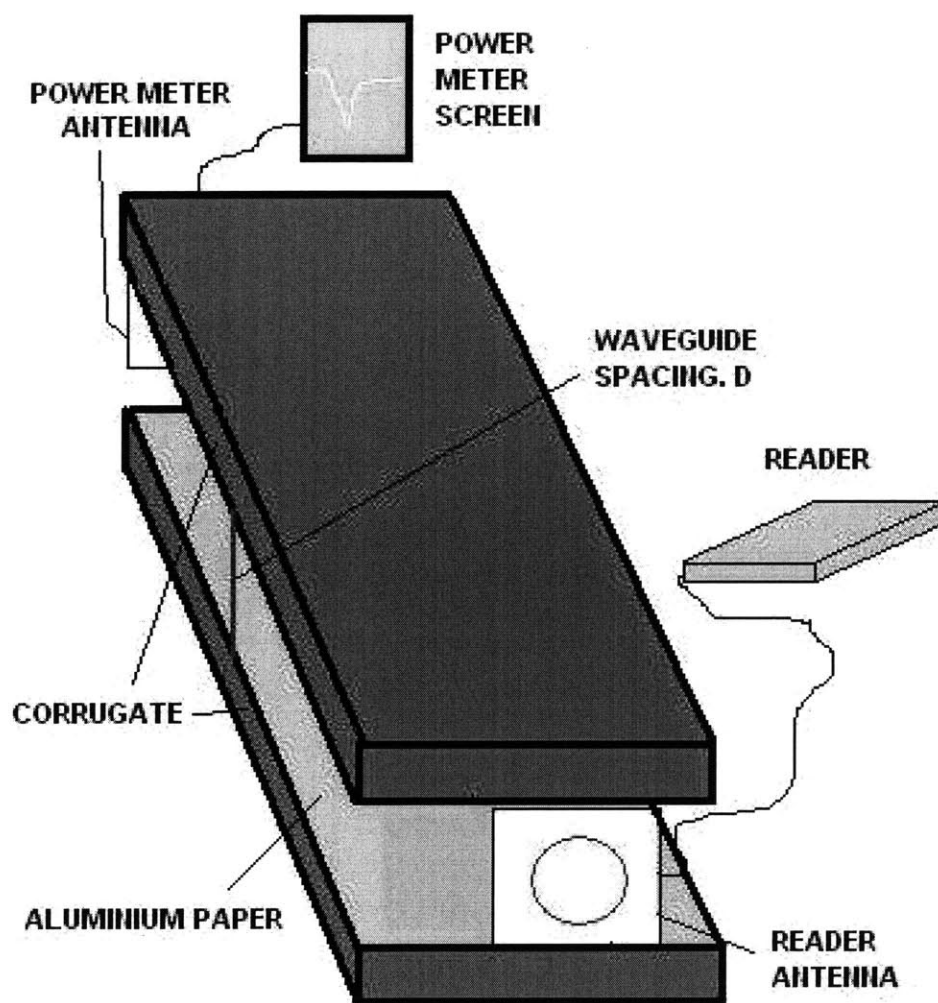

Figure 4-5: Structure 3: Circularly polarized reader antenna.



# Chapter 5

## Conductive Layering in Pallets

### 5.1 Introduction

From the studies examined in Chapter 3, it is clear that the main reason for problems in tag readability is due to the high reflection loss of most materials. I chose to investigate three possible solutions for pallet and case configuration as illustrated in Chapter 4. While this solution to propagation loss in RFID systems is not the absolute approach, it is one that should be considered for future modifications to the current pallet structure.

In this chapter, I consider these three suggested pallet structures in further detail. This section investigates their design, performance and power guidance into the center of a pallet structure in order to understand which of these three structures is most effective.

### 5.2 Study 1: Propagation into Pallet Layers

Foil conductive plates are a potential solution to low tag readability and fundamental electromagnetic challenges in reader-tag communication. Given the structures outlined in Chapter 4, it is important to see the relationship between the layer spacing,  $D$ , and the efficiency and penetration to the center of the pallet.

This study illustrates the dependence of spacing on electromagnetic field penetra-

tion into a pallet. As there are many variables involved in pallet configuration, three specific basic setups were chosen and studied in this section.

Each of these pallet structures are analyzed using a Kushcraft antenna to measure the power received after traveling through the conductive layer structure using different separations between the conductive plates in the pallet.

Although UHF readers typically use frequency hopping as required by the local government regulations [4], in this study frequency hopping is disengaged in order to produce a single frequency transmitted wave. The received power is measured at three separate transmitter frequencies: 903 MHz, 915 MHz and 927 MHz.

### 5.2.1 Structure 1

Structure 1, as shown in Figure ??, in Chapter 4, uses a linearly polarized, vertically oriented reader antenna. This configuration propagates the electromagnetic wave perpendicular to the parallel plates with a gain of  $8dB$ . The field strength at different layer spacings is shown below in Figure 5.2.1 at three different transmitter frequencies.

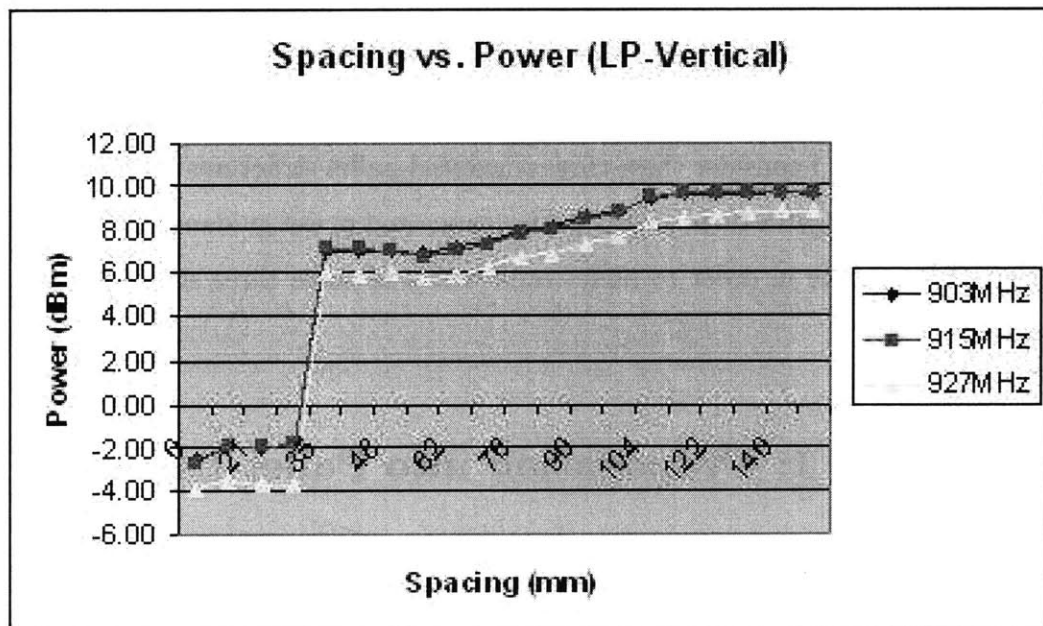

Figure 5-1: Power measured at the end of Structure 1 using a Kushcraft antenna.

## 5.2.2 Structure 2

Structure 2, as shown in Figure ??, in Chapter 4, uses a linearly polarized, vertically oriented reader antenna. This configuration propagates the electromagnetic wave parallel to the parallel plates with a gain of  $8dB$ . The field strength at different layer spacings is shown below in Figure 5.2.2 at three different transmitter frequencies.

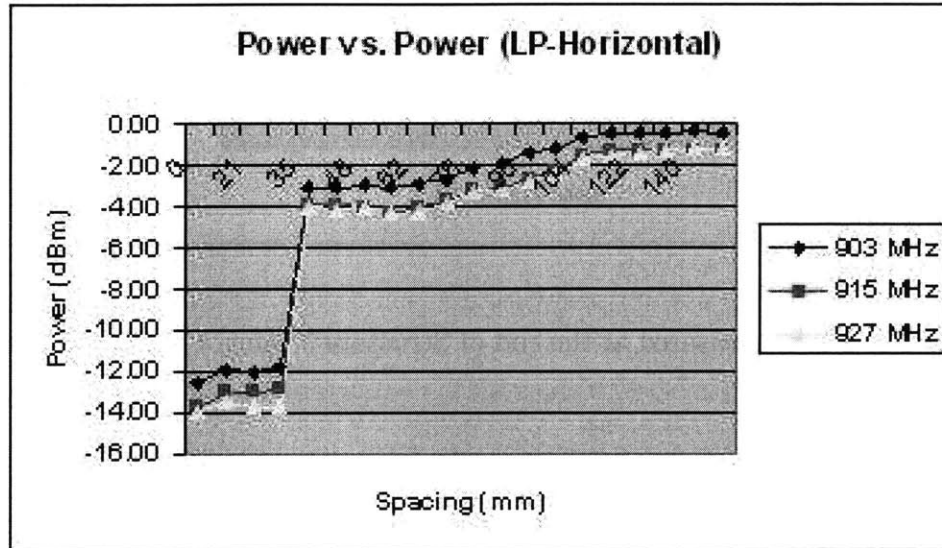

Figure 5-2: Power measured at the end of Structure 2 using a Kushcraft antenna.

## 5.2.3 Structure 3

Structure 3, as shown in Figure ??, in Chapter 4, uses a linearly polarized, vertically oriented reader antenna. This configuration propagates the electromagnetic wave parallel to the parallel plates with a gain of  $6dBi$ . The field strength at different layer spacings is shown below in Figure 5.2.3 at three different transmitter frequencies.

## 5.2.4 Study 1 Analysis

When these configurations are tested and compared, it is clear that penetration into the pallet is greatest using Structure 1. This can be explained by the fact that Structure 1 has the reader antenna transmitting its field in a linear direction that is

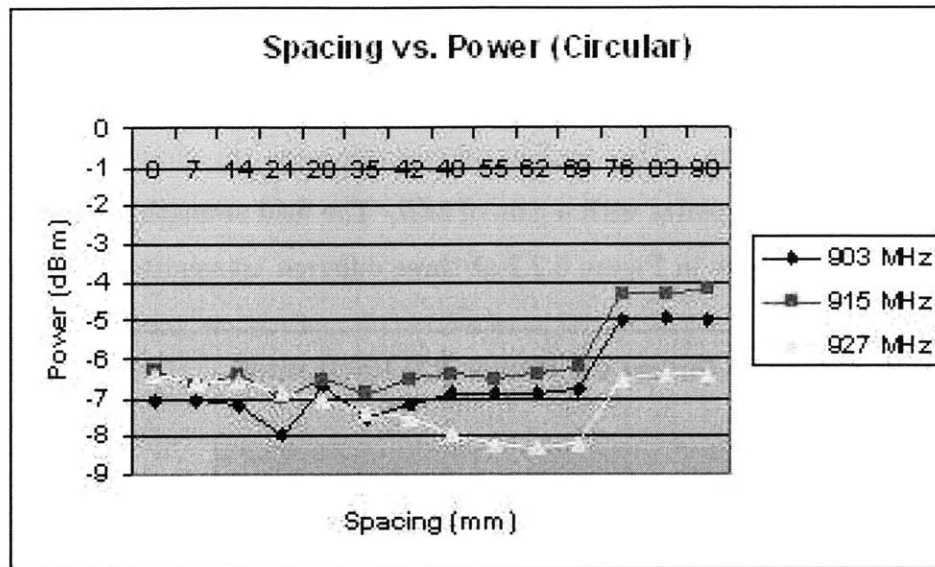

Figure 5-3: Power measured at the end of Structure 3 using a Kushcraft antenna.

perpendicular to the parallel plates of the pallet structure, which is the same as the concept that is used in the theoretical waveguide.

Structure 3 is more efficient when compared to Structure 2 because it has a horizontal and vertical transmitting field component. This means that the reader antenna transmits its field in a direction that is both parallel and perpendicular to the parallel plates of the pallet structure. However, due to government regulations, circularly polarized reader antennas have a lower gain than linearly polarized antennas. This power limitation, also limits the power that can be transmitted and received in the pallet structure, therefore Structure 3 is more useful in shorter range applications.

From Figures 5.2.1- 5.2.3, it can be seen that the power after traveling along the conductive layers is not uniform, linearly increasing or exponentially increasing. The figures show that the power requires a threshold of  $\lambda/2$  in order to provide a similar environment of propagation to that of air. This behavior is analyzed in further detail in Chapter 6.

## 5.3 Study 2: Propagation Along Pallet Layers

Given the structures outlined in Chapter 4, it is important to see the amount of power received at different depths in the parallel plates in the pallet structure. This study illustrates the dependence of pallet depth on electromagnetic field intensity.

Each of these pallet structures are analyzed using a separation of  $D = 15\text{cm}$ . In addition, a linearly polarized folded dipole antenna is used to measure the power received after traveling through the conductive layer structure at different depths in the pallet.

Although UHF readers typically use frequency hopping as required by the local government regulations [4], in this study frequency hopping is disengaged in order to produce a single frequency transmitted wave. As the folded dipole is tuned to 915 MHz, the received power is measured using the transmitter frequency of 915 MHz.

### 5.3.1 Structure 1

Structure 1, as shown in Figure ??, in Chapter 4, uses a linearly polarized, vertically oriented reader antenna. This configuration propagates the electromagnetic wave perpendicular to the parallel plates with a gain of  $8\text{dB}$ . The field strength at different depths into the pallet is shown below in Figure 5.3.1 at three different transmitter frequencies.

### 5.3.2 Structure 2

Structure 2, as shown in Figure ??, in Chapter 4, uses a linearly polarized, vertically oriented reader antenna. This configuration propagates the electromagnetic wave parallel to the parallel plates with a gain of  $8\text{dB}$ . The field strength at different depths into the pallet is shown below in Figure 5.3.2 at three different transmitter frequencies.

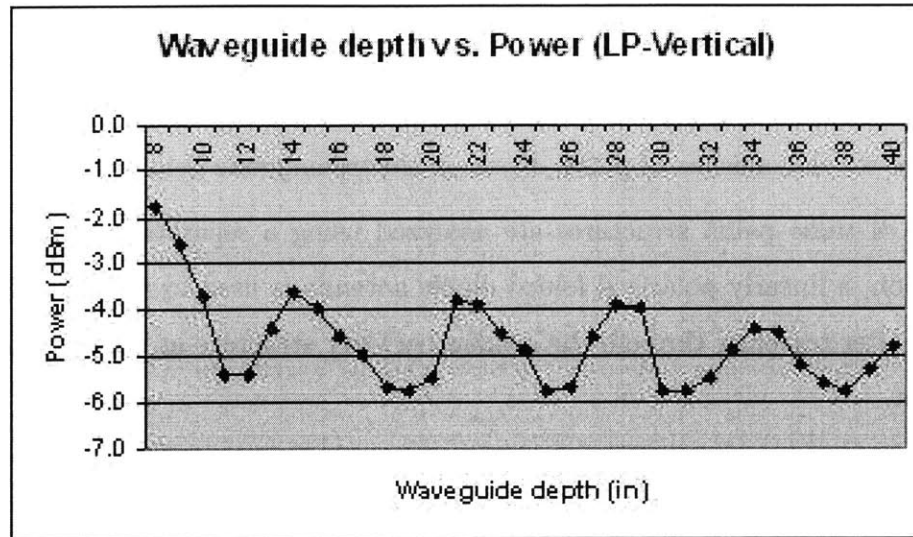

Figure 5-4: Power measured along Structure 1 using a folded dipole antenna.

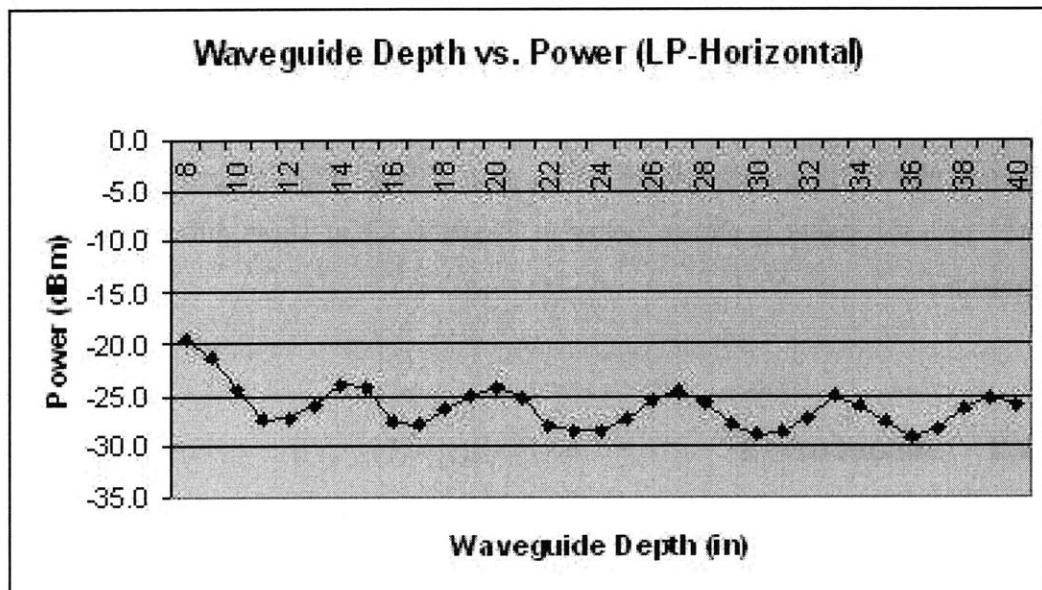

Figure 5-5: Power measured along Structure 2 using a folded dipole antenna.



### 5.3.3 Structure 3

Structure 3, as shown in Figure ??, in Chapter 4, uses a linearly polarized, vertically oriented reader antenna. This configuration propagates the electromagnetic wave parallel to the parallel plates with a gain of  $8dB$ . The field strength at different depths into the pallet is shown below in Figure 5.3.3 at three different transmitter frequencies.

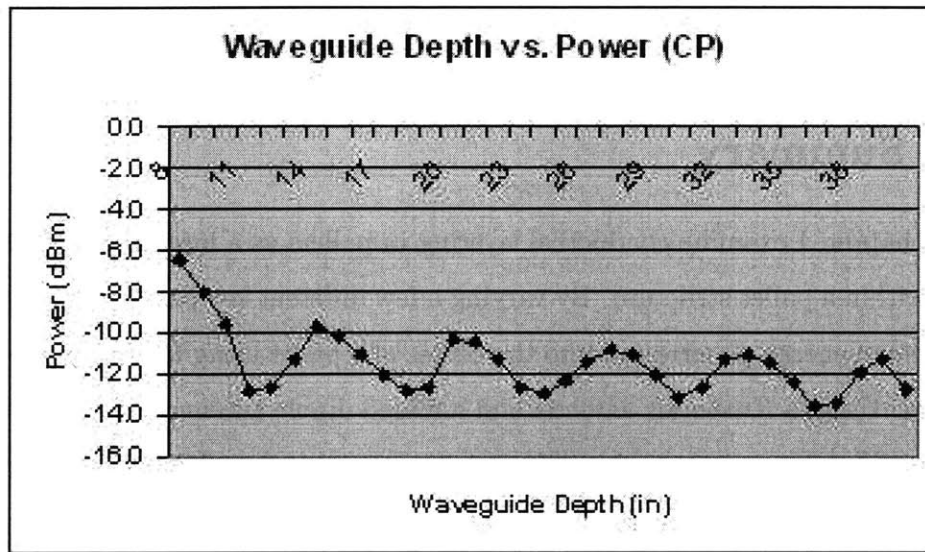

Figure 5-6: Power measured along Structure 3 using a folded dipole antenna.

### 5.3.4 Study 2 Analysis

When these configurations are tested and compared, it is clear that penetration into the pallet is greatest using Structure 1. This can be explained by the fact that Structure 1 has the reader antenna transmitting its field in a linear direction that is perpendicular to the parallel plates of the pallet structure, which is the same as the concept that is used in the theoretical waveguide.

Structure 3 is more efficient when compared to Structure 2 because it has a horizontal and vertical transmitting field component. This means that the reader antenna transmits its field in a direction that is both parallel and perpendicular to the paral-

lel plates of the pallet structure. However, due to government regulations, circularly polarized reader antennas have a lower gain than linearly polarized antennas. This power limitation, also limits the power that can be transmitted and received in the pallet structure, therefore Structure 3 is more useful in shorter range applications.

From Figures 5.3.1- 5.3.3, it can be seen that the power along the conductive layers is not uniform, linearly decreasing or exponentially decreasing. The figures show that the power exhibits a periodic behavior that repeats with a period of  $\lambda/2$ . This behavior is analyzed in further detail in Chapter 6.

## 5.4 Summary

In this chapter, I examine conductive layering in pallets as a means to increase readability within a pallet structure. By varying a few different key parameters, I examine the effects of energy penetration into the center of a pallet using foil conductive parallel plates. Using a Kushcraft antenna and a folded dipole antenna, the three different pallet configurations presented in Chapter 4 are analyzed under different conditions and it was found that Structure 1, using the linearly polarized, vertically oriented reader antenna provides the most power to the pallet RFID system. Using the information gathered from these pallet studies, I investigate the most efficient of these pallet structures, Structure 1, in further detail in Chapter 6.

# Chapter 6

## Studying Structure 1 in Depth

### 6.1 Introduction

In order to demonstrate how conductive spacing between pallet layers can be used to improve the penetration of the electromagnetic field into the pallet, Figure 4.7.1-4.7.1 are compared in Chapter 5. Using both linearly and circularly polarized reader antennas, linearly polarized receiving antennas to represent a tag and a power meter, it is shown that three different structures could be modeled in a similar manner as parallel-plate waveguides.

Given the parallel-plate model outlined in Chapter 4, it is expected that the three setups exhibit the waveguide cutoff phenomenon and perform better than air at a specific threshold spacing distance. This critical spacing is dependent on the wavelength or propagation and material properties of the packaging.

When compared to one another, Structure 1 showed more drastic and efficient results as is shown in Chapter 5. This chapter studies Structure 1 in further detail. Using the Auto-ID Labs tag emulator as well as a linearly polarized dipole antenna to represent a tag, this section investigates the performance and power guidance into the center of a pallet structure to understand the key parameters involved in wave guidance in an RFID system.

## 6.2 Study 3: Propagation into Structure 1

Foil conductive plates are a potential solution to low tag readability and fundamental electromagnetic challenges in reader-tag communication. Given the structures outlined in Chapter 4, it is important to see the relationship between the layer spacing,  $D$ , and the efficiency and penetration to the center of the pallet.

This study illustrates the dependence of spacing on electromagnetic field penetration into a pallet. Structure 1 is analyzed using an Auto-ID Labs tag emulator antenna to measure the power received after traveling through the conductive layer structure using different separations between the conductive plates in the pallet. This emulator is composed of a linearly polarized dipole antenna and is powered by a battery to perform similarly to a semi-passive tag.

Although UHF readers typically use frequency hopping as required by the local government regulations [4], in this study frequency hopping is disengaged in order to produce a single frequency transmitted wave. The received power is measured at three separate transmitter frequencies: 903 MHz, 915 MHz and 927 MHz.

Structure 1, as shown in Figure 4.7.1, in Chapter 4, uses a linearly polarized, vertically oriented reader antenna. This configuration propagates the electromagnetic wave perpendicular to the parallel plates with a gain of  $8dB$ .

### 6.2.1 903 MHz

The field strength at different layer spacings is shown below in Figure 6.2.1 at a transmitter frequency of 903 MHz. This field strength is compared to the emulator's field strength at the same transmitter frequency in air.

### 6.2.2 915 MHz

The field strength at different layer spacings is shown below in Figure 6.2.2 at a transmitter frequency of 915 MHz. This field strength is compared to the emulator's field strength at the same transmitter frequency in air.

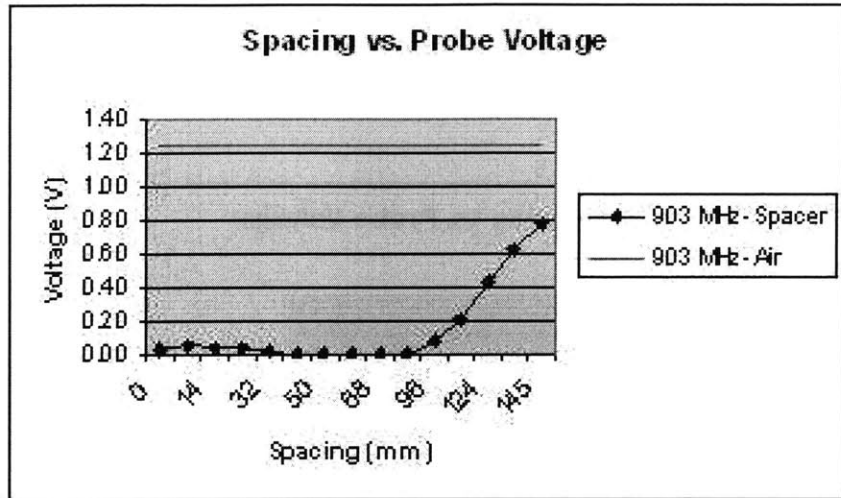

Figure 6-1: Power measured at the end of Structure 1 using a tag emulator.

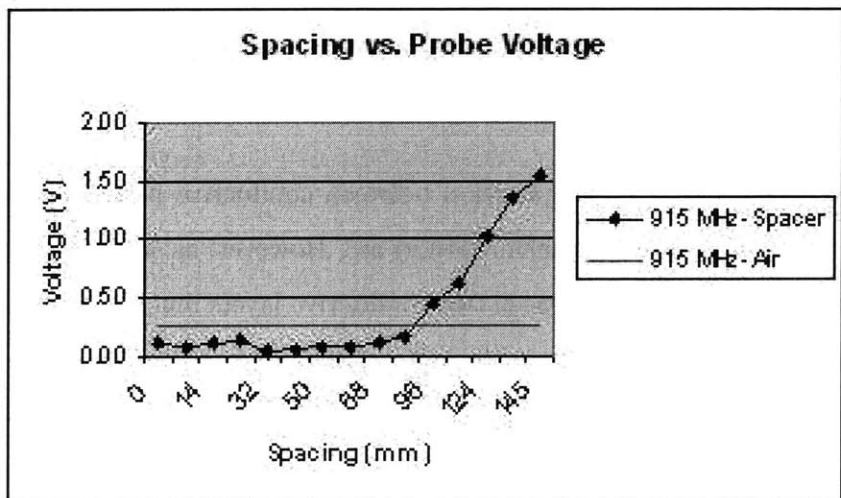

Figure 6-2: Power measured at the end of Structure 1 using a tag emulator.

### 6.2.3 927 MHz

The field strength at different layer spacings is shown below in Figure 6.2.3 at a transmitter frequency of 927 MHz. This field strength is compared to the emulator's field strength at the same transmitter frequency in air.

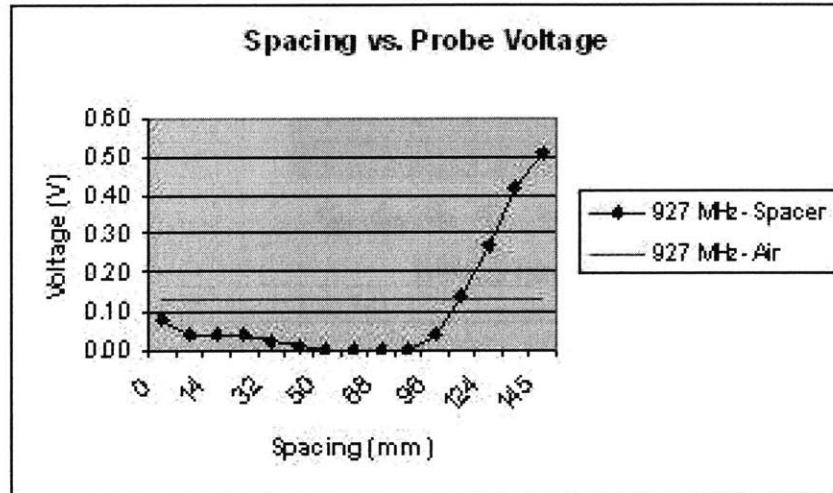

Figure 6-3: Power measured at the end of Structure 1 using a tag emulator.

### 6.2.4 Study 3 Analysis

It may be expected that *any* separation between conductive pallet layers will result in similar behavior to reader transmission in air. However, as shown in Figures 6.2.1-6.2.3, the amount of spacing between two conductive layers must be above a threshold value in order for a tag to receive sufficient power for identification.

As the tag emulator is tuned to perform at approximately  $915\text{MHz}$ , Figure 6.2.1 shows that the power received by the tag is not sufficient to guide the reader transmitted wave in a similar manner to air.

Figures 6.2.2 and 6.2.3, however, show that after this threshold spacing, the conductive layers are able to guide the transmitted wave better than the wave propagates in air.

If Equation 4.21 in Chapter 4 is slightly modified and we assumed the cutoff condition of  $k > k_{cm}$ , when  $m = 1$  we obtain

$$\begin{aligned}
 d &> \frac{m\pi}{k_{cm}} \\
 d &> \frac{m\pi}{\omega\sqrt{\mu_0\epsilon_0}} \\
 d &> \frac{\pi c}{\omega} \\
 d &> \frac{\lambda}{2}
 \end{aligned} \tag{6.1}$$

Therefore it is seen that the threshold spacing is  $\lambda/2$  or approximately  $16cm$  at  $915MHz$ . The cutoff distance that was found in these experiments fell just below this amount, at approximately  $14cm$  since the tag emulator is tuned to a frequency just above  $915MHz$ .

### 6.3 Study 4: Tag Placement Using Conductive Plates

Using Structure 1, it is important to see the amount of power received at different depths in the parallel plates in the pallet structure.

Structures 1-3 are compared in Chapter 5 to see the way that power along the waveguide varies as shown by Figures 5.3.1- 5.3.3. From these figures it can be seen that the power along the plates is not uniform, linearly decreasing or exponentially decreasing. The power exhibits a period behavior every  $\lambda/2$  or approximately every  $16cm$ .

Each of the configurations studied in this section use a linearly polarized dipole antenna measure the power received when traveling along the conductive layer structure at different depths in the pallet.

This study illustrates the dependence of pallet depth on electromagnetic field intensity. Using two different conductive materials for conductive plates, foil and conductive carbon ink, at three different spacer separations, this section analyzes

Structure 1 in further detail.

Although UHF readers typically use frequency hopping as required by the local government regulations [4], in this study frequency hopping is disengaged in order to produce a single frequency transmitted wave. As the folded dipole is tuned to 915 MHz, the received power is measured using the transmitter frequency of 915 MHz.

### 6.3.1 Foil Layers at a Spacing of 5cm

Structure 1, as shown in Figure 4.7.1, in Chapter 4, uses a linearly polarized, vertically oriented reader antenna. This configuration propagates the electromagnetic wave perpendicular to the parallel plates with a gain of 8dB. The field strength at different depths into the pallet is shown below in Figure 6.3.1 at a layer spacing of 5cm using foil layering.

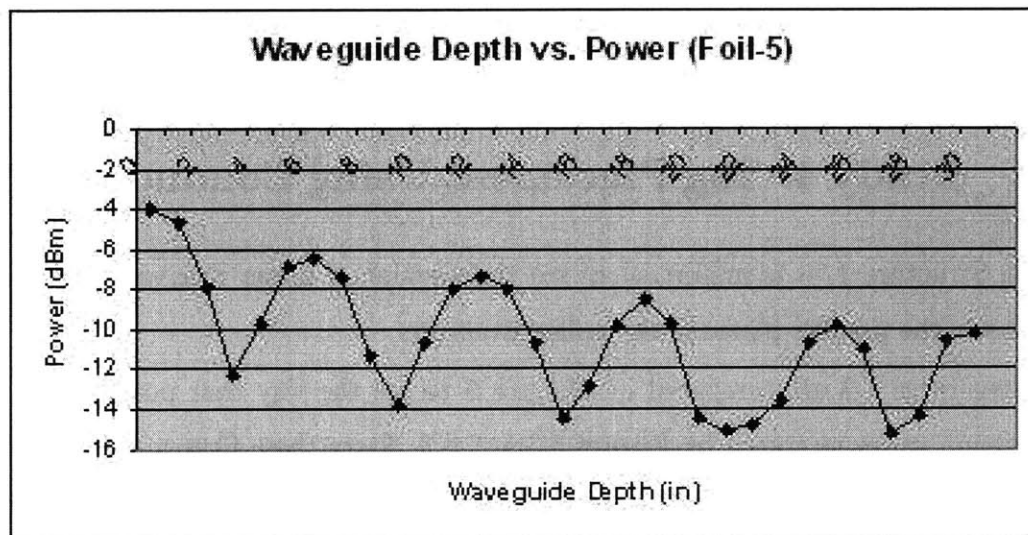

Figure 6-4: Power measured along Structure 1 using a dipole probe and a 5cm separation.

### 6.3.2 Foil Layers at a Spacing of 10cm

Structure 1, as shown in Figure 4.7.1, in Chapter 4, uses a linearly polarized, vertically oriented reader antenna. This configuration propagates the electromagnetic wave



perpendicular to the parallel plates with a gain of  $8dB$ . The field strength at different depths into the pallet is shown below in Figure 6.3.2 at a layer spacing of  $10cm$  using foil layering.

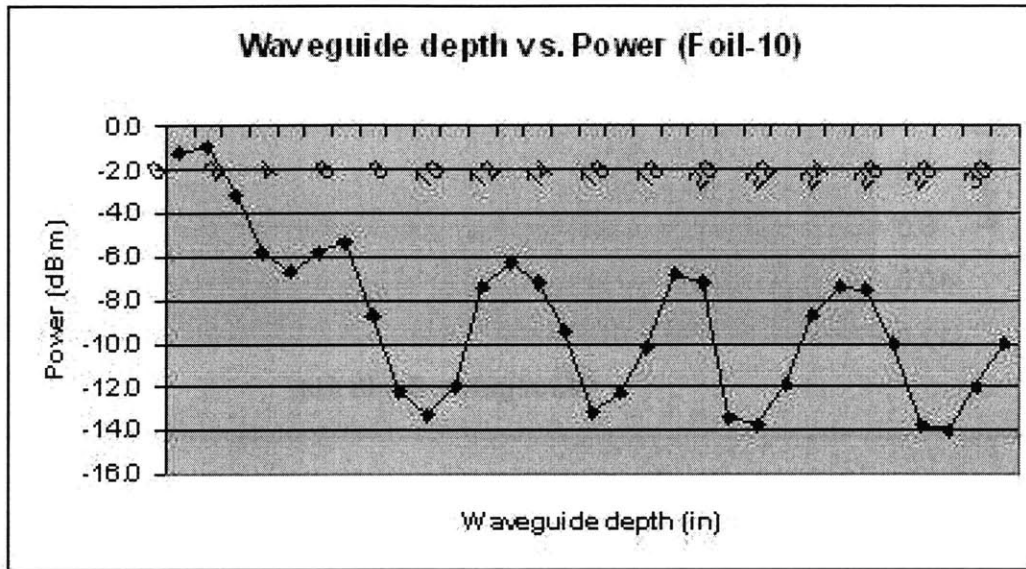

Figure 6-5: Power measured along Structure 1 using a dipole probe and a  $10cm$  separation.

### 6.3.3 Foil Layers at a Spacing of $15cm$

Structure 1, as shown in Figure 4.7.1, in Chapter 4, uses a linearly polarized, vertically oriented reader antenna. This configuration propagates the electromagnetic wave perpendicular to the parallel plates with a gain of  $8dB$ . The field strength at different depths into the pallet is shown below in Figure 6.3.3 at a layer spacing of  $15cm$  using foil layering.

### 6.3.4 Conductive Ink Layers at a Spacing of $5cm$

Structure 1, as shown in Figure 4.7.1, in Chapter 4, uses a linearly polarized, vertically oriented reader antenna. This configuration propagates the electromagnetic wave perpendicular to the parallel plates with a gain of  $8dB$ . The field strength at different

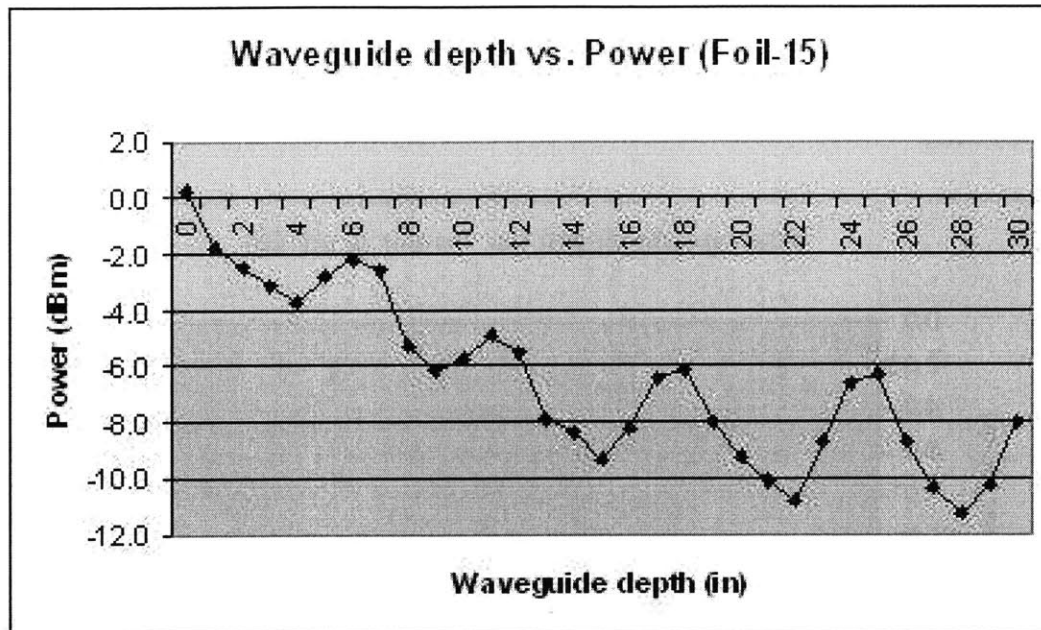

Figure 6-6: Power measured along Structure 1 using a dipole probe and a 15cm separation.

depths into the pallet is shown below in Figure 6.3.4 at a layer spacing of 5cm using conductive ink layering.

### 6.3.5 Conductive Ink Layers at a Spacing of 10cm

Structure 1, as shown in Figure 4.7.1, in Chapter 4, uses a linearly polarized, vertically oriented reader antenna. This configuration propagates the electromagnetic wave perpendicular to the parallel plates with a gain of 8dB. The field strength at different depths into the pallet is shown below in Figure 6.3.5 at a layer spacing of 10cm using conductive ink layering.

### 6.3.6 Conductive Ink Layers at a Spacing of 15cm

Structure 1, as shown in Figure 4.7.1, in Chapter 4, uses a linearly polarized, vertically oriented reader antenna. This configuration propagates the electromagnetic wave perpendicular to the parallel plates with a gain of 8dB. The field strength at different

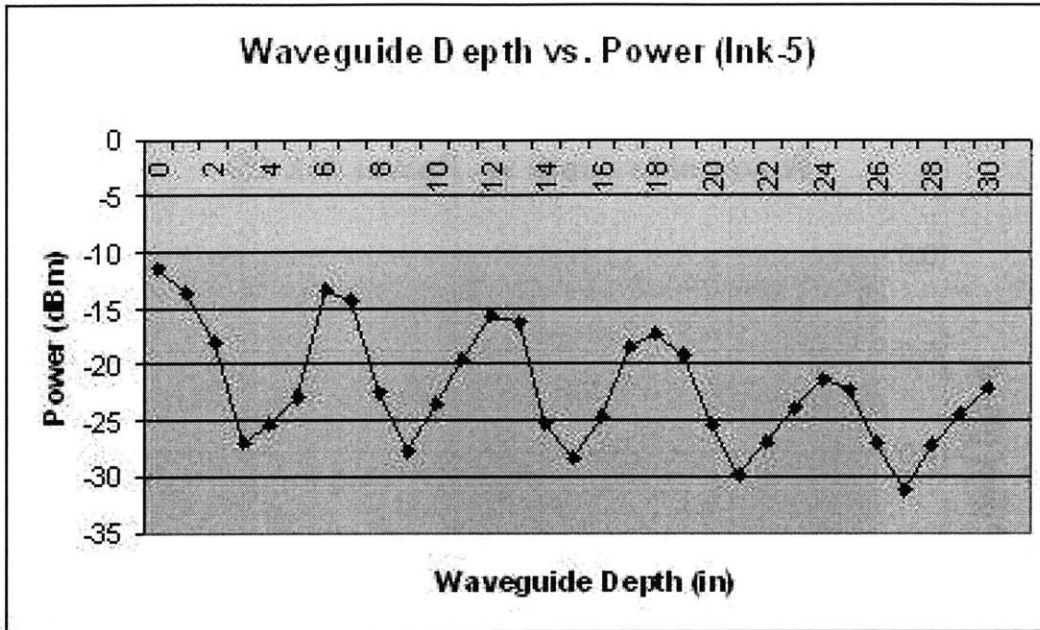

Figure 6-7: Power measured along Structure 1 using a dipole probe and a 5cm separation.

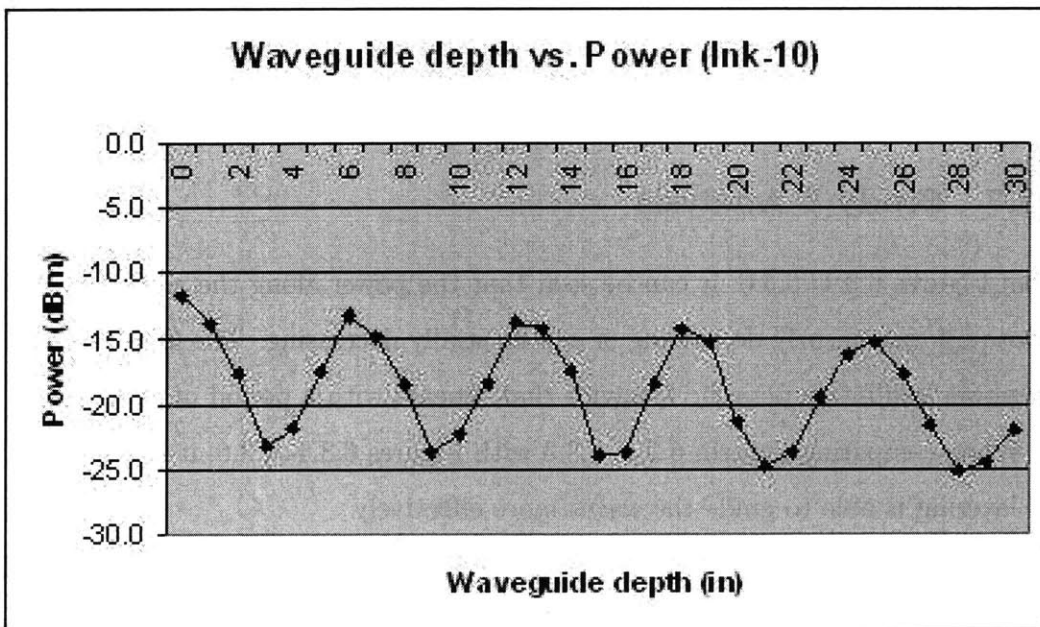

Figure 6-8: Power measured along Structure 1 using a dipole probe and a 10cm separation.

depths into the pallet is shown below in Figure 6.3.6 at a layer spacing of 15cm using conductive ink layering.

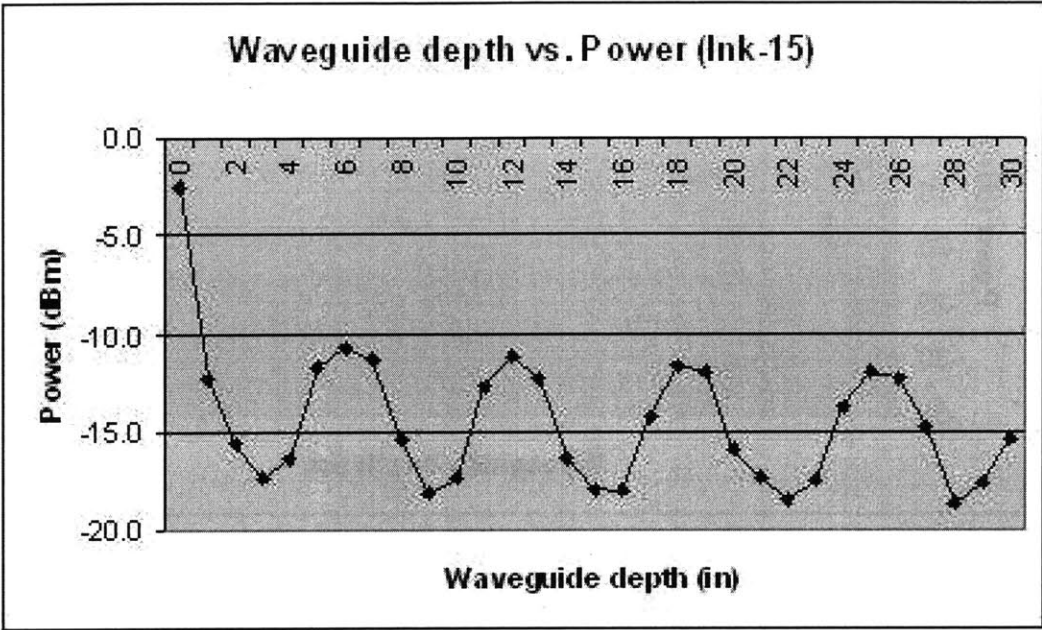

Figure 6-9: Power measured along Structure 1 using a dipole probe and a 15cm separation.

### 6.3.7 Study 4 Analysis

From Figures 6.3.1- 6.3.6, it can be seen that the power along the conductive layers is not uniform, linearly decreasing or exponentially decreasing. The figures show that the power exhibits a periodic behavior that repeats with a period of  $\lambda/2$ .

When comparing Figures 6.3.1- 6.3.3 with Figures 6.3.4- 6.3.6, it is clear that the foil layering is able to guide the waves more effectively.

Using a dipole antenna to measure the field strength, it was found that the field strength in air is approximately  $-7dBm$ . Using the foil layering at any of the three conductive spacings will be useful for wave guidance similar to air. When the conductive ink is used for layering however, it is not able to perform with the same efficiency though it is still able to guide the wave to the center of the pallet more effectively than

without the conductive separation at all since tags require a power of approximately  $-13dBm$  to be powered.

With the efficient power penetration that is provided by the foil layering, there is a tradeoff: with a more conductive material, there is a higher cost. Depending on the depth to the center of the pallet needed, the conductive material as well as the size of the gap can vary.

## 6.4 Summary

In this chapter, I examine conductive layering, using Structure 1, as a means to increase readability within a pallet structure. By varying a few different key parameters, I examine the effects of energy penetration into the center of a pallet using foil conductive parallel plates. Using an Auto-ID Labs tag emulator and dipole antenna, Structure 1, presented in Chapter 4, is analyzed under different conditions. These studies found that there is a threshold separation between the conductive layers of  $\lambda/2$ , or  $16cm$ , in order for the transmitted wave to propagate further than in air. In addition, tags must be placed at specific intervals of  $\lambda/2$  along the conductive spacers in order to receive maximum power. Using the information gathered from these pallet studies, I present practical pallet configurations using commercial products in Chapter 7.



# Chapter 7

## Practical Applications

### 7.1 Introduction

Every carton that an electromagnetic waves passes through in an RFID system cause reflection and therefore attenuate the reader transmitted signal. In water, for example, this reflection loss causes a loss of more than half of the received power. In this chapter I will suggest a few different configurations that use commercial product in order to enhance power in the RFID pallet structure.

### 7.2 Reflections

Materials with a high dielectric constant,  $\epsilon r$  will reflect more power than those with a low dielectric constant as shown in Figure 7.2. High  $\epsilon r$  layers can reflect power to the center and middle of a pallet.

With a mixed pallet, conductive layers (materials with a high  $\epsilon r$ ) can be placed at a distance of at least  $\lambda/2$  apart using low  $\epsilon r$  layers between them as shown in Figure 7.2 below.

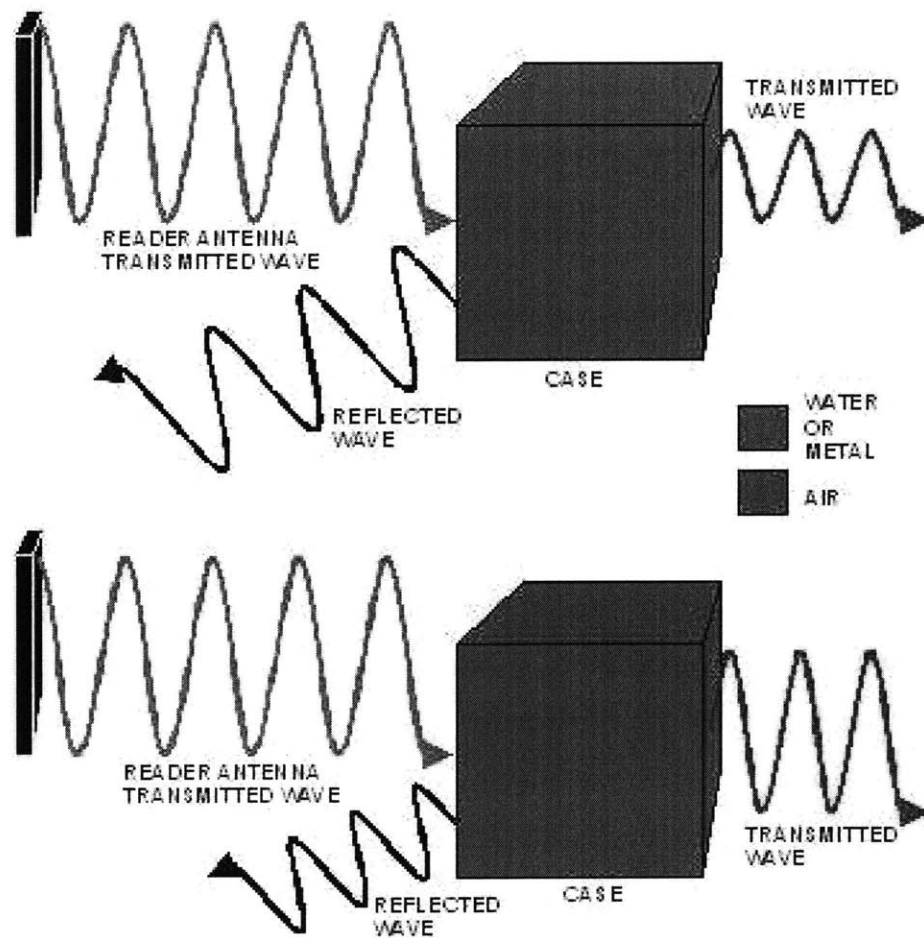

Figure 7-1: Reflected and transmitted waves in different materials.



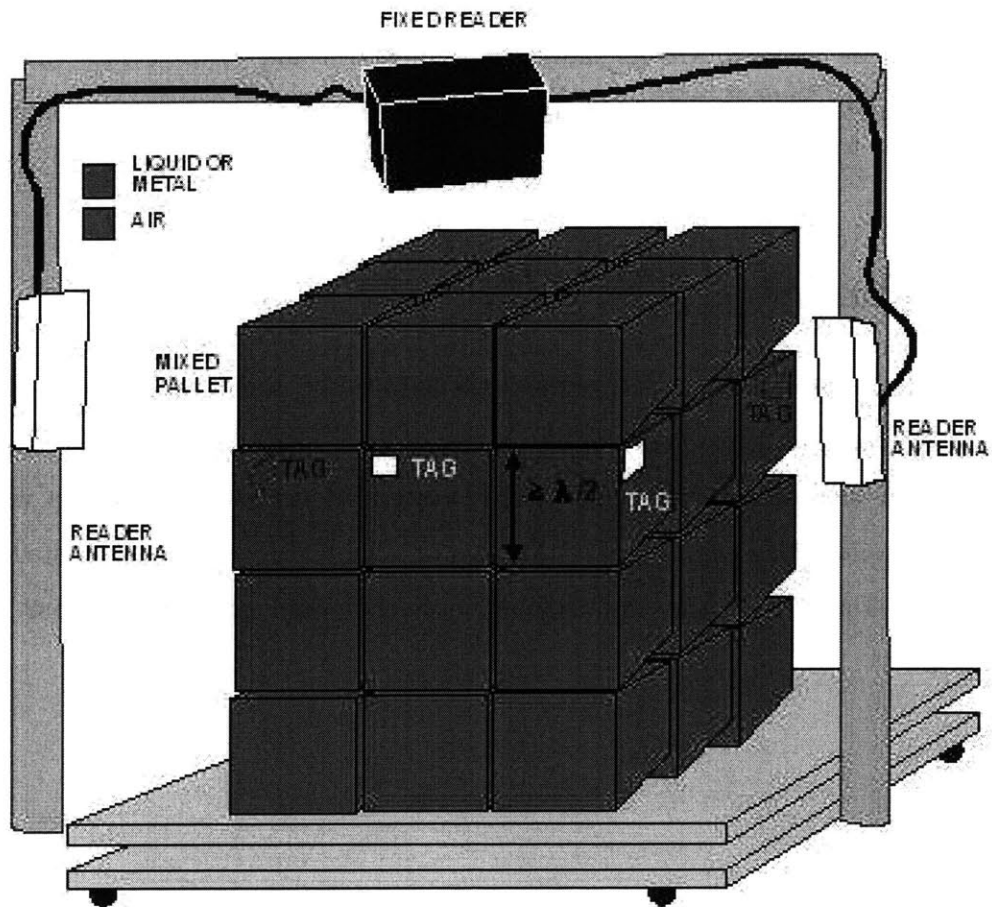

Figure 7-2: Layer dimensions in a mixed pallet.

## 7.3 Air Gaps

Air gaps in cases along with low  $\epsilon r$  layers can minimize reflection as well as penetrate power to the center of a pallet structure as shown in Figure 7.3. These air gaps can be used to channel electromagnetic energy to the center of a pallet structure.

To minimize the number of reflections as well as produce the most efficient use of conductive layering, the height of these low  $\epsilon r$  in combination with air gaps in product should be at least  $\lambda/2$  as shown in Figures 7.3 and 7.3. Power that is channeled through air gaps in cases can be maximized by staggering tags along a pallet.

## 7.4 Summary

In this chapter I present a few practical methods that can be implemented to improve the identification of multiple tags within the range of a reader in an RFID pallet. These practical methods involved the reconfiguration of the pallet structure with packaged items using the concepts of conductive parallel plates that are suggested in Chapters 3, 4, 5 and 6. In the next chapter, I conclude and present directions for future work.

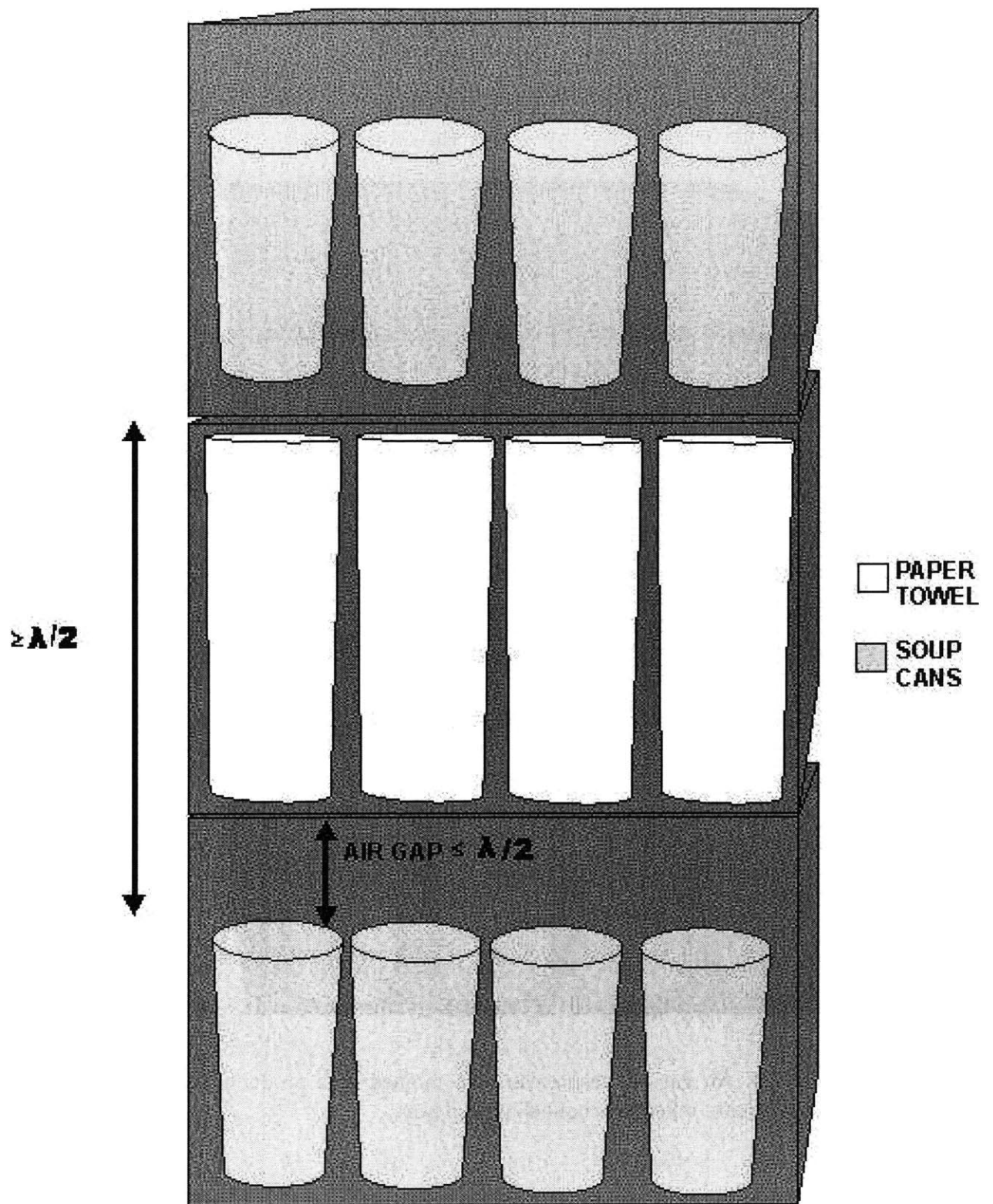

Figure 7-3: Air gaps in casing can be used to channel the power to the center of a pallet structure.

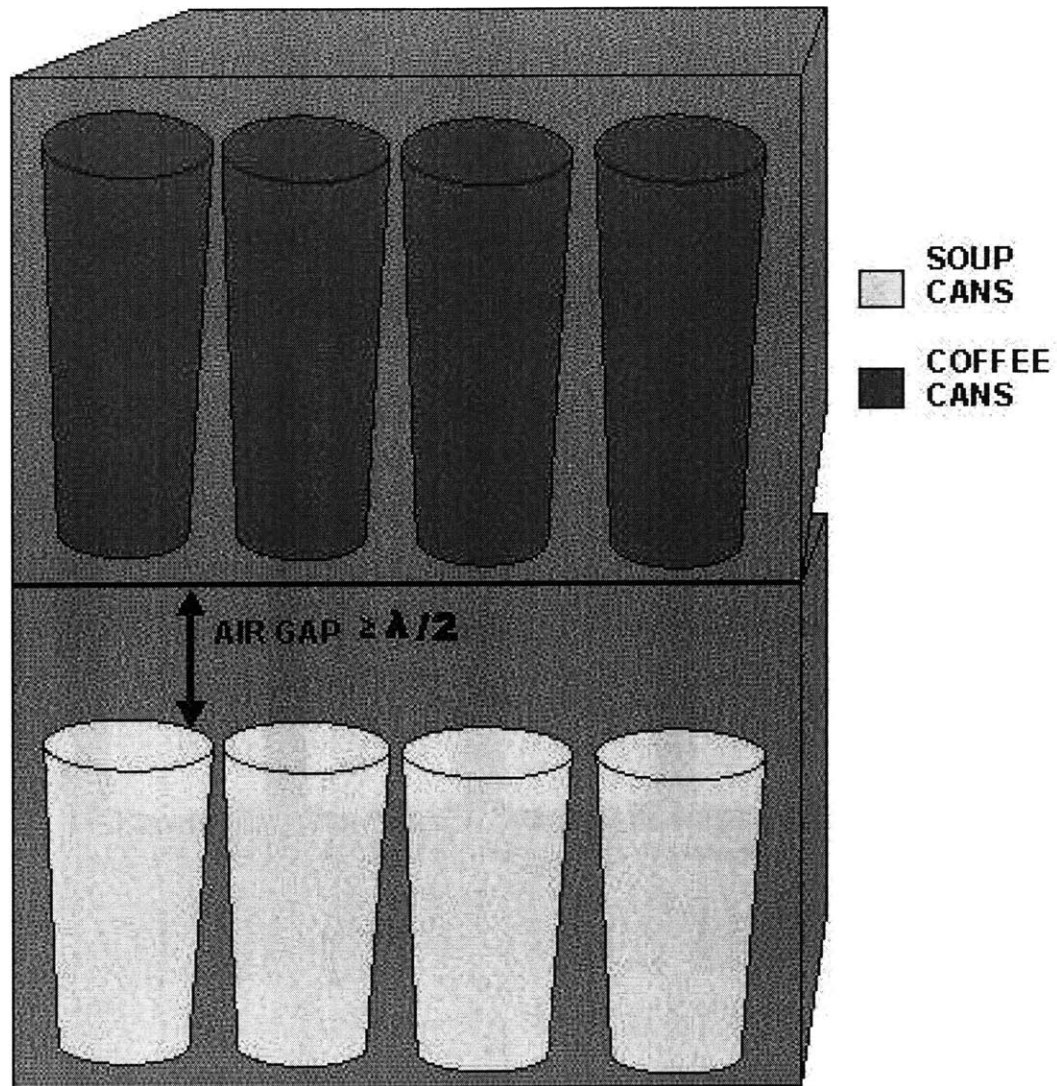

Figure 7-4: Air gaps in casing can be combined with products that perform similar to air to create reflective channeling of power.

# Chapter 8

## Conclusion

### 8.1 Conclusion

RFID was adopted in order to develop a standard architecture for creating a global network of physical objects. With the collaboration of EPCglobal, government and industry, the Auto-ID Labs continues to research and develop new technologies to provide a means for realizing RFID in global commerce. As there continue to be developments of standards for object identification and data collection, the most important near-term goal for RFID pallet structuring involves performance and cost as the power available to a tag in a pallet structure is limited by government regulations and the properties of ultra high frequencies.

As I present and analyze in this thesis, there are many fundamental challenges involved in RFID systems, which include electromagnetics, communications, regulations and implementation of pallet structuring. RFID tags perform differently according to environmental, material and electromagnetic conditions.

There are different physical mechanisms that are involved in the propagation of electromagnetic waves through a box of material; these mechanisms include reflections/scattering, absorption, and spreading loss. As a result of these mechanisms, the signal that reaches the majority of tags in standard pallets is far weaker than the original reader transmitted signal.

The tagging of cases on a pallet is a challenging problem since the same mecha-

nisms that are faced by single cases are compounded as a result of multiple cases and tags requiring identification.

Through a series of studies, it is shown in this thesis that using conductive layering in an RFID pallet structure can significantly improve identification. These conductive layers themselves are also constrained to specific dimensions that are dictated by the frequency of operation.

In these studies, passive UHF RFID structures are analyzed, therefore, the frequency of operation is  $915MHz$ . As a result, the threshold separation between the conductive layers is  $\lambda/2$ , or approximately  $16cm$ , in order for the wave to propagate further than in air.

Another important factor to consider is the periodic behavior of the guided wave along the conductive layers. This behavior requires tags to be placed at specific intervals of  $\lambda/2$  or approximately  $16cm$  along the conductive spacers in order to receive the maximum power.

With this improved identification, there is a tradeoff; with greater penetration into the pallet, there can be a slight loss in space. Depending on the depth to the center of the pallet needed, the size of the gap can vary. This means that the threshold gap between the spacer layers is also dependent on how far the pallet needs to be penetrated.

However, this does not mean that all pallet structures require a gap to guide waves to tags in the center of the pallet. As shown in Chapter 7, there are practical solutions that use commercial product to guide these waves to the center of a pallet structure.

In this thesis, I outlined the fundamental electromagnetic issues that affect the performance of RFID systems as well as provided solutions for improving and maximizing performance. While, these solutions can impose changes in the cost and size of the RFID pallet structure, I have shown that they improve some important performance specifications such as pallet read range and reader-tag communication.

## 8.2 Future Work

The physical and electromagnetic constraints imposed on RFID systems open numerous areas that require research and examination. I introduce a few of these areas here and discuss their importance with respect to future RFID applications.

The field of electromagnetics requires much attention in RFID systems and applications. Environmental influences imposed on RFID systems provide many challenges in future testing and design specifications. As demonstrated in this thesis, specific environments can change radiation patterns by altering electromagnetic fields and waves. This in turn affects the overall integrity of the RFID system.

This thesis focuses on optimizing the specific RFID environment of pallet structures as they pass through a portal. Forklifts operate in a similar manner to pallet structures through portals as they have a pallet structure. However, they require a different antenna configuration, pallet structuring and techniques for enhanced performance.

Conversely, conveyors require a smaller read range, but are constrained by the inconsistency of tag antenna geometry, orientation and placement. Future work should involve concentration on other environments involved in RFID systems and optimizing reader-tag communication in these particular applications.

This thesis used carbon ink and foil to study wave propagation along conductive plates. Further expansion of these studies would use other conductive materials to guide the wave to the center of the pallet structure.

Another interesting extension of these studies would be analyzing the performance of other conductive structures in comparison with the parallel plate structure suggested in this thesis. An alternative structure, such as a rectangular waveguide, could provide power to the RFID pallet structure in a similar way as the parallel plate structure studied in this thesis.

In the area of antenna design, there are many structures that still need to be investigated. While there has been a concentrated focus on tag antenna design, there has been little development with regards to reader antennas. As antennas allow for

many degrees of freedom in their radiation pattern, gain and directivity, there is a need for development in the area of antenna design for specific applications.

While this thesis focuses on techniques for enhancing performance within pallet structures, it will be interesting to see the function of RFID at the item level. As further standards and applications emerge in the field of RFID, they will provide numerous opportunities for extensive significant research.



# Appendix A

## Glossary

**Absorption** The amount a material changes electromagnetic power into heat.

**Aggregate** A collective unit, usually referring to a group of cases.

**Air** Any product that has properties similar to air (i.e. Styrofoam, low density packaging materials, paper-based products).

**Antenna** There are two different types of antennas: transmitting antennas and receiving antennas. A transmitting antenna changes an alternating current into an electromagnetic field. A receiving antenna changes an electromagnetic field into an alternating current.

**Attenuation** The loss of energy due to signal propagation.

**Backscattering** The electromagnetic waves that are reflected off of an object and travel away from the object. In RFID, each tag creates its own unique reflection in order to be identified.

**Case** Product packages that are ready for shipping.

**Circular Polarization** Describes that the energy emitted by an antenna radiates in multiple directions (and angles) to its plane creating a circular pattern.

**Conductivity** The ability for a material to carry electrical current. Metals and liquids are conductive materials.

**Dielectric** A material that is a poor conductor of electricity.

**Dielectric Constant,  $\epsilon_r$**  The relative permittivity of a dielectric material. Various materials have dielectric constants greater than 1. These materials are generally called dielectric materials.

**Electromagnetic Field** The result of the acceleration of charged objects.

**EIRP** Effective Isotropically-Radiated Power is the amount of power that would have to be emitted by an isotropic antenna to produce the peak power density observed in the direction of maximum antenna gain. EIRP takes into account the losses in transmission line and connectors and the gain of the antenna. The EIRP is often stated in terms of decibels over a reference power level, that would be the power emitted by an isotropic radiator with an equivalent signal strength.

$$\text{EIRP(dBm)} = (\text{power of transmitter (dBm)}) - (\text{losses in transmission line (dB)}) + (\text{antenna gain(dB)})$$

where antenna gain is expressed relative to a (theoretical) isotropic reference antenna.

**ERP** Effective Radiated Power is determined by subtracting system losses from system gains. For example, if an antenna system has +8 dB gain and -6 dB loss, its ERP is +2 dB.

**Far-Field** Electromagnetic field of an antenna at a distance greater than one wavelength from a transmitting antenna.

**Field Strength** A measure of radio signal reception.

**Frequency** The number of times a waveform occurs over a period of time (usually one second). 915 MHz means 915 million waveforms in one second.

**Gain** A measure of the ability of an antenna to focus radio waves in a particular direction.

**Hertz** A measure of frequency.

**High Frequency Tag** Tags operating at 13.56 MHz.

**IC** Integrated Circuit.

**Interference** Electrical noise occurring at the same frequency as a signal.

**Isotropic Antenna** An ideal, though not actually physical, antenna that radiates power with unit gain uniformly in all directions and is often used to reference antenna gains in wireless systems.

**Linear Polarization** Describes that the energy emitted by an antenna radiates 90 degrees to its plane creating a pattern in a straight line.

**Low Frequency Tag** Tags operating at 125 KHz.

**Metal** Any product that has metallic properties or is packaged in a metallic material.

**Microwave Tag** Tags operating at 5.8 GHz.

**Near-Field** Electromagnetic field of an antenna at a distance less than one wavelength from a transmitting antenna.

**Pallet** A group of cases that can be passed through a portal or raised by a forklift.

**Permittivity** The amount a material store electric charge. (High permittivity can store more charge than lower permittivity).

**Polarization** The directions and angles of flux lines in an electromagnetic field.

**Portal** A reading area where readers are positioned in a way to read tags going through (e.g. dock door).

**Reader** An RFID device that communicates with RFID tags and collects digital information for a computer.

**Read Range** The greatest distance from which a tag can communicate with a reader.

**Read Rate** The number of times a tag is identified over a period of time.

**Refractive Index** The parameter used to describe the interaction of electromagnetic radiation with matter.

**RF** Radio Frequency.

**RFID** Radio Frequency Identification.

**Strap** An RFID chip that is attached to an antenna to create a tag.

**Tag** An RFID device that communicates with an RFID reader to identify a product.

**Transmitter** The antenna that is used with a reader to send a radio signal to RFID tags.

**Ultra High Frequency Tag** Tags operating at 915 MHz.

**Water** Any material that has properties similar to water (i.e. all liquids).

**Wavelength** The measure of the distance from peak to peak of a waveform. For 915 MHz this is  $\approx 32\text{cm}$ .

# Bibliography

- [1] Constantine A. Balanis. *Advanced Engineering Electromagnetics*. John Wiley and Sons, Inc., New York, New York, 1989.
- [2] Constantine A. Balanis. *Antenna Theory*. John Wiley and Sons, Inc., New York, New York, 1997.
- [3] David K. Cheng. *Field and Wave Electromagnetics, 2<sup>nd</sup> ed.* Addison-Wesley Publishing Co., New York, NY, 1992.
- [4] FCC. Radio Frequency Devices. *Part 15*, 2001.
- [5] Klaus Finkenzeller. *RFID Handbook*. John Wiley and Sons, Inc., New York, New York, 1999.
- [6] Rich Fletcher, Uttara P. Marti, and Rich Redemske. Study of UHF RFID Signal Propagation Through Complex Media. *2005 IEEE International Symposium on Antennas and Propagation and USNC/URSI National Radio Science Meeting-Poster Session*, 2005.
- [7] Robert A. Kleist, Theodore A. Chapman, David A. Sakai, and Brad S. Jarvis. *RFID Labeling: Smart Labeling Concepts and Applications for the Consumer Packaged Goods Supply Chain*. Printronix, Irvine, California, 2004.
- [8] Jin Au Kong. *Electromagnetic Wave Theory*. EMW Publishing, Cambridge, Massachusetts, 2000.
- [9] James Clerk Maxwell. A Dynamical Theory of the Electromagnetic Field. *Philosophical Transactions of the Royal Society of London*, 1865.

- [10] James Clerk Maxwell. *A Treatise on Electricity and Magnetism*. reprinted: Dover Publications, 1954, New York, New York, 1891.
- [11] Tom Ahlkvist Scharfeld. An Analysis of the Fundamental Constraints on Low Cost Passive RFID System Design. Master's thesis, Massachusetts Institute of Technology, Department of Mechanical Engineering, August 2001.
- [12] David H. Staelin, Ann. W. Morgenthaler, and Jin Au Kong. *Electromagnetic Waves*. Prentice Hall, New Jersey, 1994.
- [13] Warren L. Stutzman and Gary A. Thiele. *Antenna Theory and Design, 2<sup>nd</sup> ed.* John Wiley and Sons, Inc., New York, NY, 1998.