

14.12 Game Theory Lecture Notes

Lectures 10-11

1 Repeated Games

In these notes, we'll discuss the repeated games, the games where a particular smaller game is repeated; the small game is called the stage game. The stage game is repeated regardless of what has been played in the previous games. For our analysis, it is important whether the game is repeated finitely or infinitely many times, and whether the players observe what each player has played in each previous game.

1.1 Finitely repeated games with observable actions

We will first consider the games where a stage game is repeated finitely many times, and at the beginning of each repetition each player recalls what each player has played in each previous play. Consider the following entry deterrence game, where an entrant (1) decides whether to enter a market or not, and the incumbent (2) decides whether to fight or accommodate the entrant if he enters.

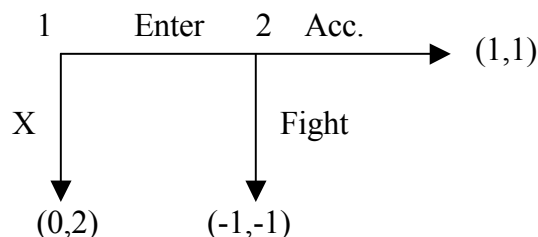

Consider the game where this entry deterrence game is repeated twice, and all the previous actions are observed. Assume that a player simply cares about the sum of his payoffs at the stage games. This game is depicted in the following figure.

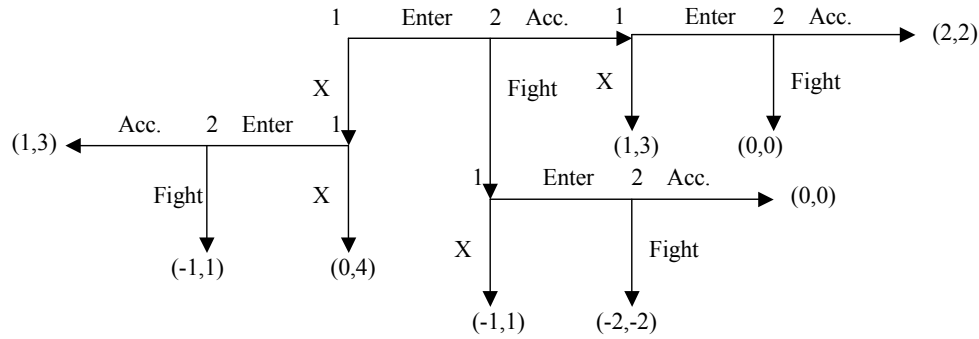

Note that after the each outcome of the first play, the entry deterrence game is played again –where the payoff from the first play is added to each outcome. Since a player’s preferences over the lotteries do not change when we add a number to his utility function, each of the three games played on the second “day” is the same as the stage game (namely, the entry deterrence game above). The stage game has a unique subgame perfect equilibrium, where the incumbent accommodates the entrant, and anticipating this, the entrant enters the market.

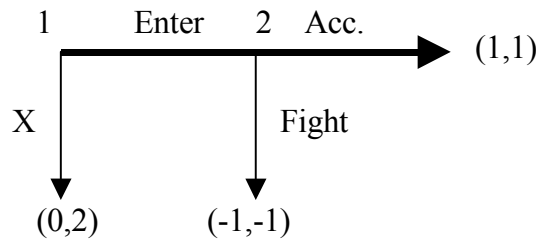

In that case, each of the three games played on the second day has only this equilibrium as its subgame perfect equilibrium. This is depicted in the following.

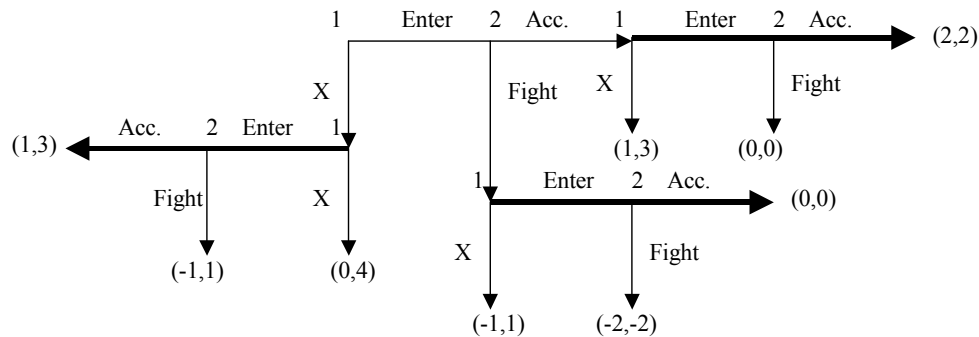

Using backward induction, we therefore reduce the game to the following.

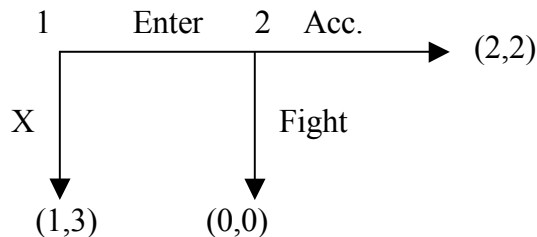

Notice that we simply added the unique subgame perfect equilibrium payoff of 1 from the second day to each payoff in the stage game. Again, adding a constant to a player's payoffs does not change the game, and hence the reduced game possesses the subgame perfect equilibrium of the stage game as its unique subgame perfect equilibrium. Therefore, the unique subgame perfect equilibrium is as depicted below.

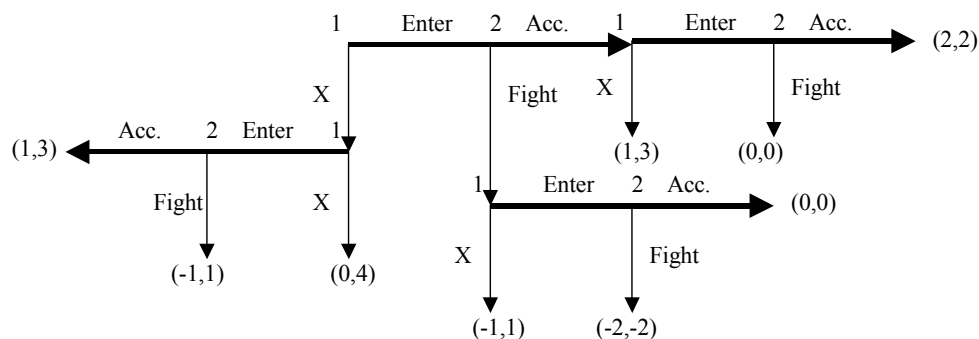

This can be generalized. That is, given any finitely repeated game with observable actions, if the stage game has a unique subgame perfect equilibrium, then the repeated game has a unique subgame perfect equilibrium, where the subgame perfect equilibrium of the stage game is played at each day.

If the stage game has more than one equilibrium, then in the repeated game we may have some subgame perfect equilibria where, in some stages, players play some actions that are not played in any subgame perfect equilibria of the stage game. For the equilibrium to be played on the second day can be conditioned to the play on the first day, in which case the “reduced game” for the first day is no longer the same as the stage game, and thus may obtain some different equilibria. **To see this, see Gibbons.**

1.2 Infinitely repeated games with observed actions

Now we consider the infinitely repeated games where all the previous moves are common knowledge at the beginning of each stage. In an infinitely repeated game, we cannot simply add the payoffs of each stage, as the sum becomes infinite. For these games, we will confine

ourselves to the case where players maximize the discounted sum of the payoffs from the stage games. The *present value* of any given payoff stream $\pi = (\pi_0, \pi_1, \dots, \pi_t, \dots)$ is computed by

$$PV(\pi; \delta) = \sum_{t=0}^{\infty} \delta^t \pi_t = \pi_0 + \delta \pi_1 + \dots + \delta^t \pi_t + \dots,$$

where $\delta \in (0, 1)$ is the *discount factor*. By the *average value*, we simply mean

$$(1 - \delta) PV(\pi; \delta) \equiv (1 - \delta) \sum_{t=0}^{\infty} \delta^t \pi_t.$$

Note that, when we have a constant payoff stream (i.e., $\pi_0 = \pi_1 = \dots = \pi_t = \dots$), the average value is simply the stage payoff (namely, π_0). Note that the present and the average values can be computed with respect to the current date. That is, given any t , the present value at t is

$$PV_t(\pi; \delta) = \sum_{s=t}^{\infty} \delta^{s-t} \pi_s = \pi_t + \delta \pi_{t+1} + \dots + \delta^k \pi_{t+k} + \dots.$$

Clearly,

$$PV(\pi; \delta) = \pi_0 + \delta \pi_1 + \dots + \delta^{t-1} \pi_{t-1} + \delta^t PV_t(\pi; \delta).$$

Hence, the analysis does not change whether one uses PV or PV_t , but using PV_t is simpler.

The main property of infinitely repeated games is that the set of equilibria becomes very large as players get more patients, i.e., $\delta \rightarrow 1$. given any payoff vector that gives each player more than some Nash equilibrium outcome of the stage game, for sufficiently large values of δ , there exists some subgame perfect equilibrium that yields the payoff vector at hand as the average value of the payoff stream. This fact is called the folk theorem. **See Gibbons for details.**

In these games, to check whether a strategy profile $s = (s_1, s_2, \dots, s_n)$ is a subgame perfect equilibrium, we use the *single-deviation principle*, defined as follows.¹ Take any formation set, where some player i is to move, and play a strategy a^* of the stage game according to the strategy profile s . Assume that the information set is reached, each player $j \neq i$ sticks to his strategy s_j in the remaining game, and player i will stick to his strategy s_i in the remaining game except for the information set at hand. given all these, we check whether the player has an incentive to deviate to some action a' at the information set (rather than playing a^*). [Note that all players, including player i , are assumed to stick to this strategy profile in the remaining game.] The single-deviation principle states that if there is no information set the

¹Note that a strategy profile s_i is an infinite sequence $s_i = (a_0, a_1, \dots, a_t, \dots)$ of functions a_t determining which “strategy of the stage game” to be played at t depending on which actions each player has taken in the previous plays of the stage game.

player has an incentive to deviate in this sense, then the strategy profile is a subgame perfect equilibrium.

Let us analyze the infinitely repeated version of the entry deterrence game. Consider the following strategy profile. At any given stage, the entrant enters the market if and only if the incumbent has accommodated the entrant sometimes in the past. The incumbent accommodates the entrant if and only if he has accommodated the entrant before. (This is a switching strategy, where initially incumbent fights whenever there is an entry and the entrant never enters. If the incumbent happens to accommodate an entrant, they switch to the new regime where the entrant enters the market no matter what the incumbent does after the switching, and incumbent always accommodates the entrant.) For large values of δ , this is an equilibrium.

To check whether this is an equilibrium, we use the single-deviation principle. We first take a date t and any history (at t) where incumbent has accommodated the entrants. According to the strategy of the incumbent, he will always accommodate the entrant in the remaining game, and the entrant will always enter the market (again according to his own strategy). Thus, the continuation value of incumbent (i.e., the present value of the equilibrium payoff-stream of the incumbent) at $t + 1$ is

$$V_A = 1 + \delta + \delta^2 + \dots = 1/(1 - \delta).$$

If he accommodates at t , his present value (at t) will be $1 + \delta V_A$. If he fights, then his present value will be $-1 + \delta V_A$. Therefore, the incumbent has no incentive to fight, rather than accommodating as stipulated by his strategy. The entrant's continuation value at $t + 1$ will also be independent of what happens at t , hence the entrant will enter (whence he gets $1 + \delta$ [His present value at $t + 1$]) rather than deviating (whence he gets $0 + \delta$ [His present value at $t + 1$]).

Now consider a history at some date t where the incumbent has never accommodated the entrant before. Consider the incumbent's information set. If he accommodates the entrant, his continuation value at $t + 1$ will be $V_A = 1/(1 - \delta)$, whence his continuation value at t will be $1 + \delta V_A = 1 + \delta/(1 - \delta)$. If he fights, however, according to the strategy profile, he will never accommodate any entrants in the future, and the entrant will never enter, in which case the incumbent will get the constant payoff stream of 2, whose present value at $t + 1$ is $2/(1 - \delta)$. Hence, in this case, his continuation value at t will be $-1 + \delta \cdot 2/(1 - \delta)$. Therefore, the incumbent will not have any incentive to deviate (and accommodate the entrant) if and only if

$$-1 + \delta \cdot 2/(1 - \delta) \geq 1 + \delta/(1 - \delta),$$

which is true if and only if

$$\delta \geq 2/3.$$

When this condition holds, the incumbent do not have an incentive to deviate in such histories. Now, if the entrant enters the market, incumbent will fight, and the entrant will never enter in the future, in which case his continuation value will be -1 . If he does not enter, his continuation value is 0. Therefore, he will not have any incentive to enter, either. Since we have covered all possible histories, by the single-deviation principle, this strategy profile is a subgame perfect equilibrium if and only if $\delta \geq 2/3$.

Now, study the cooperation in the prisoners' dilemma, implicit collusion in a Cournot duopoly, and other examples in Gibbons.