

Accuracy Analysis and Improvement for Direct Laser Sintering

Y. Tang¹, H. T. Loh^{1,2}, J. Y. H. Fuh², Y. S. Wong², L. Lu², Y. Ning², X. Wang²

¹Singapore-MIT Alliance, National University of Singapore

²Department of Mechanical Engineering, National University of Singapore

Abstract—The accuracy issue of a rapid prototyping-direct laser sintering system is studied in this paper. The sources of errors are analyzed for their contribution to the final accuracy of built parts. The error sources are related to the hardware and software of the machine, the materials and the process. Special measures were exploited to improve the accuracy of the direct laser sintering system and process. For the errors caused by hardware like laser scanner, compensation by software was developed to correct the errors resulting from galvano-mirrors and F- θ lens. A compensation function mode was added to the slicing software to compensate the errors caused by material shrinkage and laser beam offset. Based on the analysis and improvement, a desired accuracy of 0.2mm has been achieved for the direct laser sintering system, which was verified by experiments.

Index Terms—Accuracy, Compensation, Correction, Direct laser sintering, Rapid prototyping

I. INTRODUCTION

EVER-growing global competition forces manufacturers to deliver more competitive products

Manuscript received November 4, 2003. This work was jointly supported by Singapore-MIT Alliance and Department of Mechanical Engineering, National University of Singapore.

Y. Tang is with Singapore-MIT Alliance, National University of Singapore, E4-04-10, 4 Engineering Drive 3, Singapore 117576 (phone: 65-68744857; fax: 65-67795922; e-mail: smatyx@nus.edu.sg).

H. T. Loh is with the Singapore-MIT Alliance and Mechanical Engineering Department, National University of Singapore, 10 Kent Ridge Crescent, Singapore 119260 (e-mail: mpelht@nus.edu.sg).

J. Y. H. Fuh is with the Mechanical Engineering Department, National University of Singapore, 10 Kent Ridge Crescent, Singapore 119260 (e-mail: mpefyh@nus.edu.sg).

Y. S. Wong is with the Mechanical Engineering Department, National University of Singapore, 10 Kent Ridge Crescent, Singapore 119260 (e-mail: mpewys@nus.edu.sg).

L. Lu is with the Mechanical Engineering Department, National University of Singapore, 10 Kent Ridge Crescent, Singapore 119260 (e-mail: luli@nus.edu.sg).

Y. Ning is with the Mechanical Engineering Department, National University of Singapore, 10 Kent Ridge Crescent, Singapore 119260 (e-mail: engp0941@nus.edu.sg).

X. Wang is with the Mechanical Engineering Department, National University of Singapore, 10 Kent Ridge Crescent, Singapore 119260 (e-mail: mpewxh@nus.edu.sg).

with better quality, lower price and shorter fabrication time. Rapid prototyping (RP) technologies have received significant interests from both research and industrial communities based on the above trend. As an advancing manufacturing technology, the rapid prototyping technology has a major concern in the accuracy issue. Overall, to achieve complete accuracy with no error is impossible. The error can be reduced but will not be completely eliminated. It is important to understand where errors can occur and how it will affect the outcome. Usually, if the error is small, the outcome will not be affected. However, large error can change the final product drastically. There is continuing research on accuracy of rapid prototyping, and improved accuracy models are constantly devised. M. Yan et al analyzed the machine accuracy for rapid prototyping and pointed out the most common sources of errors in the rapid prototyping and manufacturing systems can be categorized as mathematical, process-related or material-related errors [1]. Fadel and Kirschman discussed the accuracy issues when a CAD file was translated into rapid prototyping control codes [2]. J. Y. Choi, et al studied the errors in medical rapid prototyping models and discovered that the laser diameter, laser path, and thickness of the layer are other sources of errors [3]. A. Gregorian, et al used benchmark and optimal shrinkage compensation factors (SCF) to improve the accuracy in rapid prototyping machine (FDM-1650) [4]. S. J. J. Lee, E. Sachs, and M. Cima investigated the effect of layer position accuracy on powder-based processes such as three dimensional printing (3D-P) and selective laser sintering (SLS) [5].

As one of the rapid prototyping technologies, the direct laser sintering process faces its own particular error sources. The laser system, especially the laser scanning system will be the main source of error formation from the hardware point of view. And as a thermal process, the shrinkage, distortion and even the warpage may result in tremendous errors in the built parts. Therefore, it is very important to perform accuracy analysis and introduce improvement for direct laser sintering. The research work reported in this paper is aimed at a direct laser sintering system under development, in which the plastic, sand and metal powders can be directly sintered into final parts. Accuracy issues relating the hardware and software of

machine were analyzed and the measures for correction and compensation were also applied in order to achieve high accuracy in part fabrication.

II. ACCURACY ANALYSIS-SOURCES OF ERRORS

A. Errors caused by laser scanning system

Direct laser sintering builds a part by using a laser beam to scan and sinter powder materials layer by layer. The laser scanning path is realized by reflecting a laser beam through two rotating galvano-mirrors in the X and Y directions. The configuration and mechanism of the two galvano-mirrors laser scanning system is shown in Fig. 1.

As a rotating motion system, the two galvano-mirrors scanning system has quite different characteristics from that of a linear-motion system in terms of its effect on the laser scan path. The movement of laser scan spot realized by the two galvano-mirrors can be described as follows:

- (1) A point on the surface of the Y mirror is set as the origin and the surface of platform is taken to be at a level where $z=D$;
- (2) The distance between the center of X and Y mirrors is taken to be e ;
- (3) The projection angles of the beam with the XZ and YZ planes are θ_x and θ_y respectively;
- (4) The travel length of the beam from the center of the X mirror to the focus point in XY plane is f_r which will be used for calculating the change of focal length.

$$\left\{ \begin{array}{l} x = \left(\sqrt{D^2 + y^2} + e \right) \tan \theta_x \\ y = D \tan \theta_y \\ f_r = \frac{x}{\sin \theta_x} \end{array} \right. \quad (1)$$

Hence all x , y , f_r can be described by angles θ_x , θ_y :

$$\left\{ \begin{array}{l} x = \left(\frac{D}{\cos \theta_y} + e \right) \tan \theta_x \\ y = D \tan \theta_y \\ f_r = \frac{1}{\cos \theta_x} \left(e + \frac{D}{\cos \theta_y} \right) \end{array} \right. \quad (2)$$

From equation (2), it can be seen that the position of the laser spot is determined by the rotating angles θ_x and θ_y . The focus distance f_r is also changing according to various θ . In order to get the laser beam focused on a horizontal plane which represents the working surface, a

F-Theta lens has been used in our machine. The F-Theta lens has a special optical design which allows the different parts of lens to have different focus distance according to the entry angle of the laser beam. This allows the laser beam spot to be focused on a linear plane when the mirror is rotated, albeit with a slight error. The mechanism of the F-Theta lens is shown in Fig. 2.

The rotating motion of two mirrors and the F-Theta objective cause barrel-shaped distortions of the image field as shown in the Fig. 3 [6]. This distortion will obviously affect the shape and accuracy of the built parts and correction and calibration are needed to eliminate this effect. Furthermore, some distortions are caused by the mirror and lens due to their fabrication and configuration. All the distortions and errors can and should be corrected and compensated by software.

B. Errors caused by material shrinkage

As a thermal process, direct laser sintering will unavoidably be accompanied by material shrinkage. The shrinkage is the result of thermal and phase change effects. Some books in RP area have already given detailed descriptions about the theoretical analysis for material shrinkage (i.e. [7, 8]). However, in practice, the distortion is more than mere shrinkage, especially for direct laser sintering in which high temperature is applied to sinter high melting-point materials like metals. The shrinkage affects not only the final dimensions of parts, but also result in distortion and warpage. In general, the distortion and warpage can be eliminated by optimizing the process parameters like laser power, scanning speed and scanning spacing etc, or even applying a pre-heating for the direct laser sintering process. But the effect of shrinkage to the dimension accuracy is always unavoidable.

Therefore, compensation should be made for the direct laser sintering process. If the shrinkage rate for a special material under fixed process parameters is uniform, the problem could simply be solved by enlarging the CAD model with a fixed compensation factor. But in fact, the shrinkage is usually locally variable due to the changing dimension and geometry. Hence a more accurate statistical approach has to be applied for our machine to get the compensation factor for a specific material.

C. Errors caused by laser beam spot size and HAZ

The spot size of the laser beam after focusing is 0.6mm in diameter, hence an offset of 0.3mm should be considered as radius compensation just similar to normal CNC machining. However, in direct laser sintering process, the offset should also consider the heat affected area (HAZ) caused by the laser beam to the material. In a way, the HAZ compensates for the effect of shrinkage, because it results in material expansion. Hence the offset of laser beam, HAZ and shrinkage of the material should be considered together, and a combined compensation

factor should be determined by experiments using the statistical method.

D. Errors caused by slicing software

Some errors are inevitable due to the slicing algorithm itself. For example, using curve fitting algorithm may cause the Chordal deviation error. And a stair-case error in the x and y directions may occur for curved contours when a large scanning spacing is used. Similarly, a stair-case error in the Z-axis is resulted from the fabrication of laminated parts using a large layer thickness. All these errors can be reduced by improving the slicing algorithm. In our system, a range of options are provided that allow the slicing software to create laser scanning path in single route, double route and folding route, and a fitting contour route is also provided as an optional operation. Before slicing, the quality of the STL file is also important to the final accuracy that can be achieved. When a CAD design is translated into STL file, finer triangle surfaces give more accuracy in the slicing process.

E. Random errors

Parts made by the same process, using the same material and parameters, in the same machine run by the same trained people, simply are not identical. This is due to random errors. A simple function was given by Dr. Jacobs to describe the random errors as follows [9]:

$$\sigma_s = K\bar{S} \quad (3)$$

where K is a constant called random error coefficient for a given process, σ_s is the standard deviation of the random noise error, \bar{S} is the mean process error. From equation (3), we know that the lower the mean error in the direct laser sintering process, the lower the difference between the parts with identical process conditions. Also, the random error can be partially compensated by the statistical approach for the shrinkage, offset and HAZ compensation. So in the experiments for improving the accuracy, the consideration of random error was also hidden in the combined compensation factors.

III. CORRECTION AND COMPENSATION

A. Correction and calibration of laser scanning system

A special software has been developed for correcting the distortions and errors caused by laser scanning system. The principle of the correction software is based on equation (2). The errors in x, y values are corrected by modifying the values of rotating angles θ_x and θ_y . The operation of correction software is as follows:

- (1) Put a sheet of white paper on the working surface of the machine, use the laser scanning system and let the laser beam to draw a standard square ($300 \times 300 \text{ mm}^2$) on the paper;
- (2) The draught square may have a distortion, measure the biggest errors along the central lines of X, Y directions, get the data of Δx and Δy (see Fig. 4(a));
- (3) Input the Δx and Δy into the software, the software will automatically calculate the modifications for every point of the square, and correct the distorted square into the normal square (see Fig. 4 (b)).

After the correction, the distortion can be eliminated in the scanning area. But there is another problem that the dimensions of the square may not be exactly the required ones. There are still dimensional errors which could be the result of the complicated calculation for distortion correction and the arrangement of working table to the laser scanning system. These errors should also be corrected and we call this operation as calibration. The operation of calibration is also a function of the software and it is similar to the distortion correction:

- (1) Draw a standard square ($300 \times 300 \text{ mm}^2$) on a paper;
- (2) Measure the dimensions in X, Y directions, get the errors of dx and dy according to the required dimensions (see Fig. 5(a));
- (3) Input the dx and dy into the software, the software will automatically calibrate the dimensions into required ones (see Fig. 5 (b)).

B. Combined compensation for material shrinkage, laser beam offset, HAZ and random errors

Based on the analysis for errors caused by material shrinkage, laser beam offset, HAZ, as well as random errors, a combined compensation has been considered for eliminating these errors. The realization of combined compensation is based on following equation:

$$\begin{cases} X = K_x X' - O_x \\ Y = K_y Y' - O_y \end{cases} \quad (4)$$

where X' and Y' are measured dimensions of the model part in x and y directions, the X and Y are modified dimensions after compensation. K_x and K_y are scaling factors which are expected to compensate the material shrinkage and random errors. O_x and O_y are offsets to compensate the errors caused by the laser spot and HAZ.

The values of K_x and K_y , O_x and O_y are determined by experiments using a statistical method. The model part for determining the scale factors and offset values are shown in Fig. 6, the part include several parallel blocks in X and Y directions with different dimensions without any scale and offset compensation. Then the model part is built in the direct laser sintering machine. After building, all dimensions are carefully measured. Then a plot of errors versus nominal dimension is made for X and Y directions

respectively. A linear fit to these points is then determined. The slope of the line is equal to the scaling factor, while the intercept is equal to twice of the offset.

The scaling factor and offset values will be input into the slicing software, then all dimensions of the designed parts will be compensated before sintering, and the final parts built by direct laser sintering will have the desired accuracy.

IV. EXPERIMENTS AND RESULTS

A. Experiments

Experiment was carried out to build the model part shown in Fig. 6. Before the building, the machine was carefully calibrated in X, Y and Z directions. Especially for the laser scanning system, it was corrected and calibrated with the correction and calibration software for several times. Two parts were built using the same set of parameters. One was built without compensation for determining the scale factors and offset values. Another was built after compensation, for comparison to the first one to determine the results of the compensation.

B. Results

The model part built from the direct laser sintering machine is shown in Fig. 7. The material for this part is Nylon-based plastic.

The designed and measured dimensions of the model part in X and Y directions (see Fig. 6 and Fig. 7) are shown in Table 1.

From the data of Table 1, it could be calculated that:

$$\begin{cases} X' = 0.969X + 0.74 \\ Y' = 0.98Y + 0.46 \end{cases} \quad (5)$$

Thus, the designed dimensions could be modified according to following equation:

$$\begin{cases} X = 1.032X' - 0.76 \\ Y = 1.02Y' - 0.47 \end{cases} \quad (6)$$

From equation (6), the scaling factors and the offsets for compensation could be obtained as follows:

$$\begin{cases} K_x = 1.032 \\ O_x = 0.38 \\ K_y = 1.02 \\ O_y = 0.235 \end{cases} \quad (7)$$

These data was then input into the slicing software, and the software produced the modified dimensions for

direct laser sintering. After building, the dimensions of the part are shown in Table 2.

From Table 2, it can be seen that the errors of all dimensions in X and Y directions have been mostly compensated. All errors are within 0.2mm with only one exception.

V. CONCLUSION

Being a thermal process, the direct laser sintering has a more complicated and serious problem regarding the accuracy issue, as compared to other RP processes. The errors resulted by direct laser sintering are mainly caused by laser scanning system, material shrinkage, laser beam offset and HAZ, slicing software and random errors. The distortion and dimension errors caused by laser scanning system can be corrected and eliminated by a special software. The errors caused by material shrinkage, laser beam offset, HAZ and random errors can be compensated by a combined compensation method. After correction and compensation, the errors are within 0.2mm.

REFERENCES

- [1] M. Yan, P. Gu, X. Huang and X. Zhang, "Analysis of machine accuracy for rapid prototyping of quality components", *Proceedings-of-SPIE, The-International-Society-for-Optical-Engineering*, V3517, 1998, pp 91-101
- [2] G. M. Fadel, and C. Kirschman, "Accuracy Issues in CAD to RP Translations", *Rapid Prototyping Journal*, Vol. 2, No. 2, 1996, pp 4-17
- [3] Y. Choi, et al, "Analysis of errors in medical rapid prototyping models", *Int J Oral Maxillofac Surg*, Feb., 2002, 31(1), pp 23-32
- [4] A. Gregorian, et al. "Accuracy Improvement In Rapid Prototyping Machine (FDM-1650)", *Solid Freeform Fabrication Proceedings*, 2001, pp 77-84
- [5] S. J. J. Lee, E. Sachs, and M. Cima, "Powder Layer Position Accuracy in Powder-Based Rapid Prototyping", *Solid Freeform Fabrication Proceedings*, 1993, pp 223-236
- [6] SCANLAB GmbH, "Installation and Operation, PC Real Time Control Board RTC2, for Scan Head and Laser Control in Time", 1998
- [7] P.F.Jacobs, et al, "Rapid Prototyping and Manufacturing, Fundamentals of Stereolithography", *Society of Manufacturing Engineers*, 1992
- [8] J. J. Beaman, "Solid Freeform Fabrication, A New Direction in Manufacturing", *Kluwer Academic Publishers*, Boston, MA, 1997
- [9] P. F. Jacobs, et al, "The Effects of Shrinkage Variation On Rapid Tooling Accuracy", *Materials & Design*, Vol. 21, No.2, April, 2000, pp 127-136

FIGURES AND TABLES

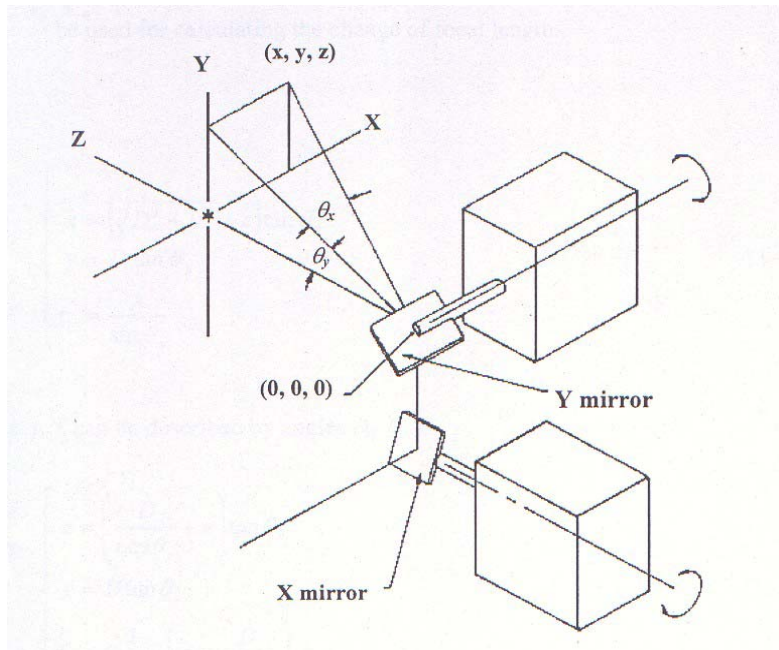

Fig. 1 Two galvano-mirrors laser scanning system

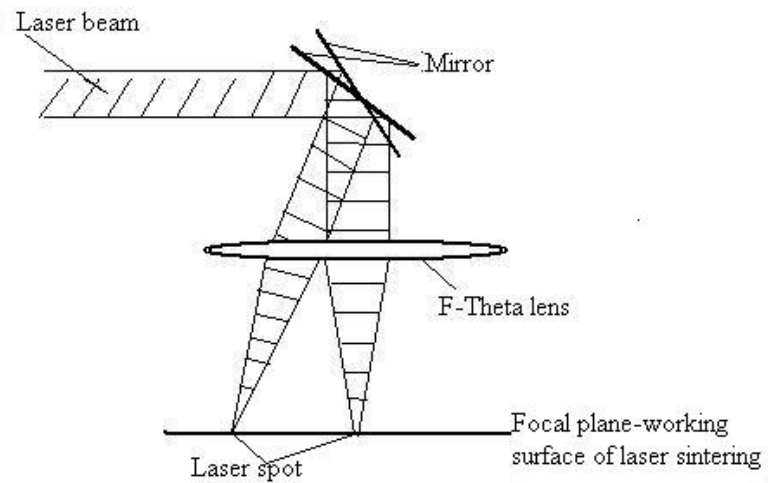

Fig. 2 Focal plane obtained through F-Theta lens

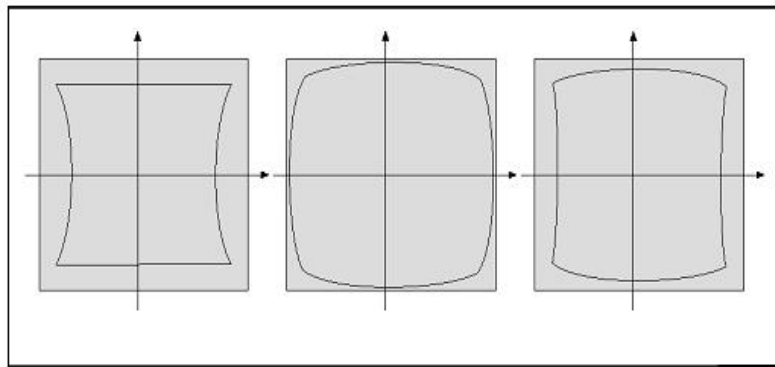

Fig. 3 Barrel-shaped distortions caused by laser scanning system

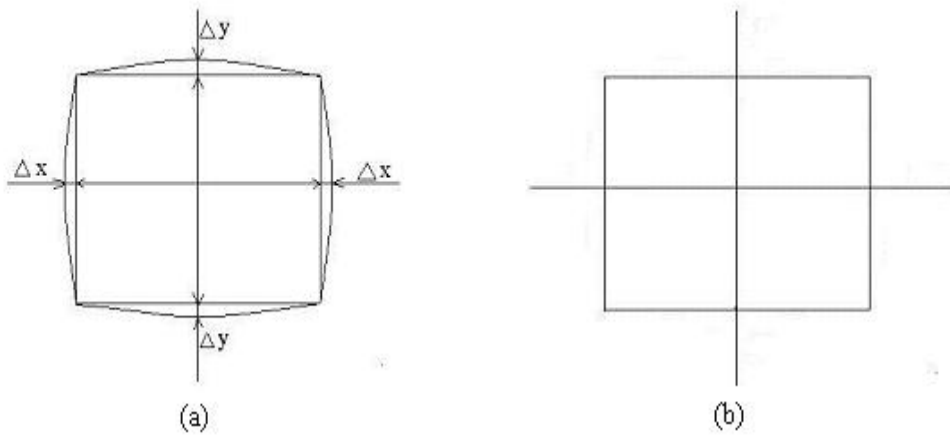

Fig. 4 Correction of the distortion caused by laser scanning system

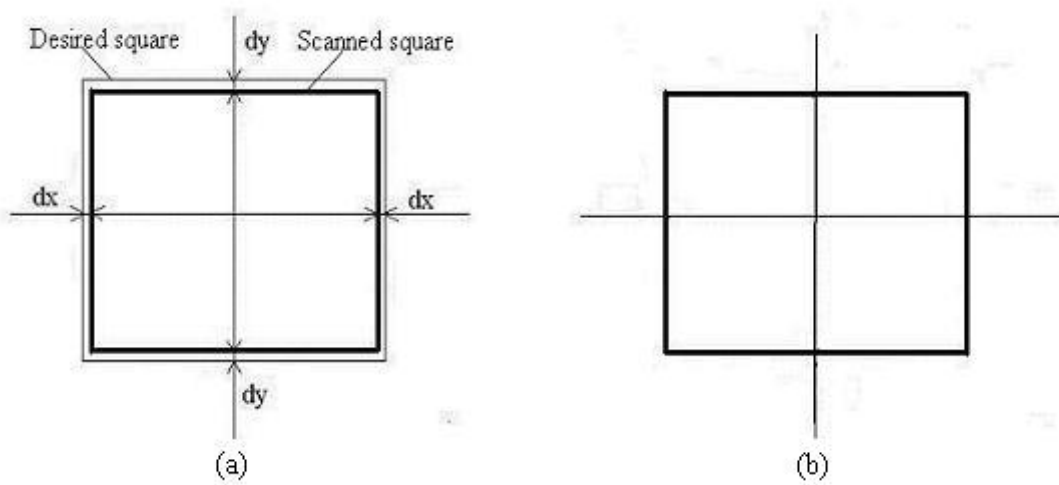

Fig. 5 Calibration of dimension errors

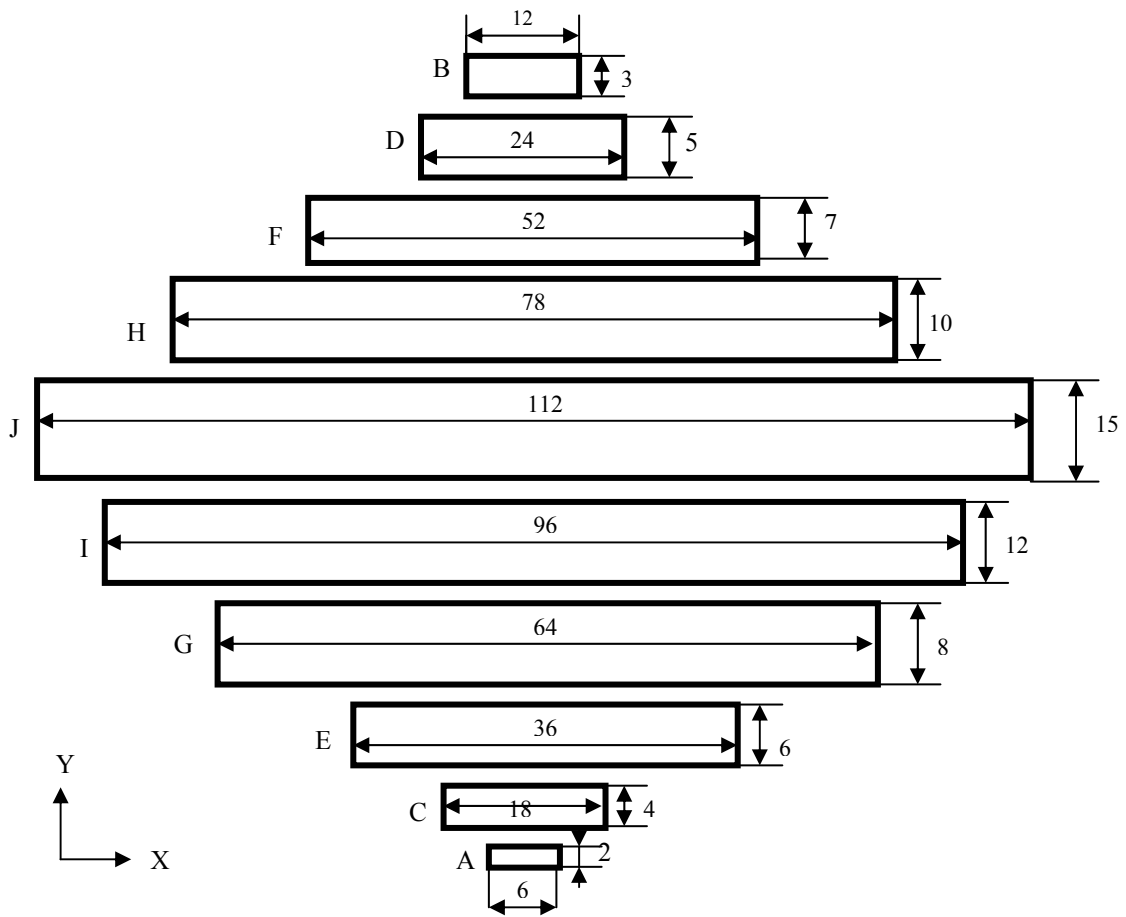

Fig. 6 Model part used for determining the scale factors and offset values

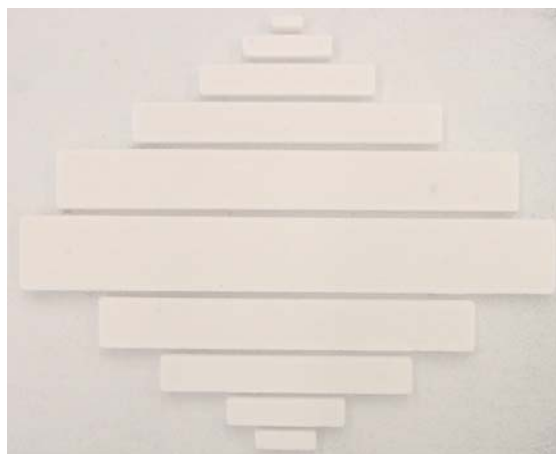

Fig. 7 Model part built from direct laser sintering machine

Table 1 Designed and measured dimensions of model part

Part	A	B	C	D	E	F	G	H	I	J
X	6	12	18	24	36	52	64	78	96	112
Y	2	3	4	5	6	7	8	10	12	15
X'	6.56	12.48	18.22	24.12	35.59	52.12	62.64	76.28	93.72	109.30
Y'	2.42	3.41	4.37	5.38	6.32	7.25	8.31	10.37	12.19	15.16

Table 2 Dimensions after compensation

Part	A	B	C	D	E	F	G	H	I	J
X	6	12	18	24	36	52	64	78	96	112
Y	2	3	4	5	6	7	8	10	12	15
X'	5.87	12.04	18.18	24.13	36.05	52.17	64.24	78.19	96.17	112.17
Y'	2.11	3.06	4.18	5.19	6.18	7.08	8.16	10.02	12.08	15.13