

Valuable Bridges:  
Cable-Stayed Bridges and Value Engineering in  
American Civil Engineering Culture, 1969-1979

by

Fallon M. Samuels  
B.S. Columbia University, 2005

SUBMITTED TO THE DEPARTMENT OF ARCHITECTURE IN PARTIAL FULFILLMENT OF THE  
REQUIREMENTS FOR THE DEGREE OF

MASTER OF SCIENCE IN ARCHITECTURE STUDIES  
AT THE  
MASSACHUSETTS INSTITUTE OF TECHNOLOGY

SEPTEMBER 2007

© 2007 Massachusetts Institute of Technology, All rights reserved.

Signature of Author: \_\_\_\_\_  
Department of Architecture  
August 20, 2007

Certified by: \_\_\_\_\_  
John Ochsendorf  
Assistant Professor of Architecture and Building Technology  
Thesis Supervisor

Accepted by: \_\_\_\_\_  
Julian Beinart  
Professor of Architecture  
Chairman, Department Committee for Graduate Students

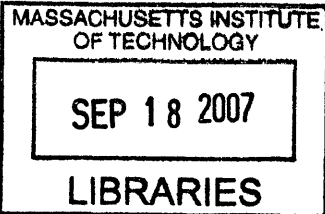

ROTCH



Valuable Bridges:  
Cable-Stayed Bridges and Value Engineering in  
American Civil Engineering Culture, 1969-1979

By

Fallon M. Samuels

Submitted to the Department of Architecture  
On August 20, 2007 in Partial Fulfillment of the  
Requirements for the Degree of Master of Science in  
Architecture Studies

ABSTRACT

A history and theory of cable-stayed bridges in the context of a cultural discourse on civil construction projects' value, this thesis studies the significance of cable-stayed bridge designs to 'value engineering' objectives for major highway bridge projects of the 1970s. This study of preliminary designs and feasibility studies for highway bridges presents the alternate bridge designs versus alternative bridge typologies selected during this period as one instance of American civil engineering culture adapting to major bridge projects the economically measured but industrial approach to choosing, reconfiguring and eliminating construction systems of value engineering. Only as analytical mechanisms of bridge construction that figure as economically competitive in prevailing market conditions do the high-capital and technologically innovative bridge designs of the Luling Bridge (LA, 1978) and the Pasco-Kennewick Bridge (WA, 1977) develop into physical constructions built almost exclusively with federal highway funds. This shift in cable-stayed bridge designs' fate from abandoned projects in the 1960s is discussed as the reflection of structural engineers' engaging in the post-capitalist practices of analytical and then physical systems building, decision analysis, speculation as well as the interdisciplinary cultures from which these concepts stem. Critical studies of preliminary designs and construction industry data circa 1970 reveal cable-stayed bridge type selections to be at once the linchpin to politicization of VE in American highway bridge building by 1979 and the Achilles heel of an American civil engineering culture that sought a renaissance in bridge engineering not a redefinition of its principles through a new method of planning for alternate futures.

Thesis Supervisor: John Ochsendorf  
Title: Assistant Professor of Architecture and Building Technology



## ACKNOWLEDGEMENTS

I would like to thank God above all for giving me strength and wisdom but most of all the support of so many mentors, peers, friends and family throughout my studies and this thesis process. Grateful acknowledgements are thus extended to my boyfriend Kwamena Aidoo always open to the ideas swirling in my mind and willing to give compassionate criticism, my mother remaining an emblem of professionalism and a shoulder to lean on and my father's 'good genes' for reading and reading and reading. With their support, I was able to absorb the frustrations of detours and to learn from feedback my thesis advisor and readers so generously offered me along the way.

Special thanks are given to Prof. John Ochsendorf, who continued to push me to become a better scholar and to meet my own expectations for graduate work here at MIT. Even when the demands of his scholarly activities required his undivided attention, John made the time to personally teach me the path to a successful academic career in architectural studies as a structural engineer. With the aid of both he and Prof. Mark Jarzombek inside and outside of the classroom, I learned how to tell the story of my research with an eye towards the audience of architecture and technology history today. Last but not least, without the graciousness of Cynthia Stewart, Renee Caso, Annette Horne-Williams and Elizabeth Pierre of the Architecture Department as well as Dean Blanche Staton of the Graduate Students Office, I would not have navigated the bureaucracies of interdisciplinary studies and the uniqueness of academic culture with assurance that things would work out in the end.

Thank you again to all whom give me cause to celebrate with pride and a sense of accomplishment my moving into the next stage of academic studies and a new phase of my professional career. May someone else receive the same blessings I was afforded. I will not forget that to whom much is given, much is required.

## BIOGRAPHIC NOTE

Fallon M. Samuels receives the M.S. in Architecture Studies from the interdisciplinary “SMArchS” program of Architecture and Technology, in which she focused on the history and theory of structures and structural engineers in design culture. Prior to her graduate studies at MIT, Fallon studied structural engineering and architecture at Columbia University, where she received a B.S. in civil engineering and a minor in architecture from the Schools of Engineering and Applied Science and Architecture, Planning and Preservation in May of 2005. Fallon has worked as a structural engineering intern for DMJM of Iselin, NJ and HNTB Architecture, Inc. of New York, but saw a more fitting professional career in her internship at the Smithsonian Institution’s Division of Architectural History and Historic Preservation. From collaborative work on a Historic Structures Reports with the Division’s director and co-founder of the National Building Museum, Cynthia Stewart, Fallon contributed historical studies of the Arts & Industries Building to an international exhibition on the architect Adolf Cluss hosted in Germany and the U.S. in 2006. Still intrigued by structural designs’ role in mediums and venues of exhibition, exploration and interrogation, Fallon continues her academic studies at Harvard University’s Graduate School of Design, where her PhD studies in architecture will focus on the history and theory of structural designs in the context of visual, architecture and planning cultures of the United States and its territories.

## Table of Contents

Introduction .....	8
Problem Statement.....	13
Overview of Thesis Study.....	18
Literature Review.....	21
Methodology.....	26
Chapter 1: VE and the Value Control of U.S. Highway Bridge Projects .....	30
Chapter 2: Cost and Geometry Control of Cable-Stayed Bridge Projects.....	62
Conclusion.....	91
Bibliography .....	99
Primary Sources .....	99
Secondary Sources .....	106

## Introduction

Despite a growing interest in 20<sup>th</sup> century civil engineering culture and history of bridges, the design of bridges since the Second World War remains greatly unexplored. The handful of critical studies of cable-stayed bridges and dually cable-stayed and suspended bridges examine innovations in bridge form and technology through a focus on how war-time American aerodynamics research (Scott, 1997) and German engineers' research of long-span structures (Podolny & Scalzi, 1986, Billington & Nazmy, 1990) enabled the maturity of this bridge type's technical composition and advanced cable-stayed bridges' reception or adoption by various engineering communities and cultures. Each study surveys the material, technological and formal composition, of over fifty bridge structures, for which self-weight and loading are supported by an arrangement of inclined steel cables anchored to the bridge rather than river banks or piers as is required of suspension bridges (fig. 1).

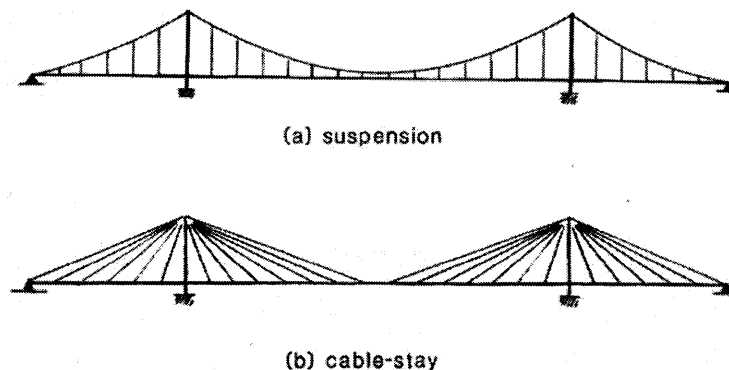

**Figure 1. Anchorage Differences for the Suspension and Cable-Stayed Bridges**  
(from Podolny, "Cable-Stayed Bridges", *AISC Convention*, 1973)

None of these historical studies have taken a more focused look at the cultural development of ideas that undergird the growth of cable-stayed bridge designs in built and unbuilt form. Aesthetic problem-solving, construction planning in design, and aerodynamic engineering of long-span suspended structures are presented as



frameworks for the consideration of cable-stayed bridges, particularly in the United States in the 1980s, but only Scott expands upon the significance of any of these concepts and practices to the contexts in which engineers designed and constructed cable-stayed bridges prior to 1980. If attention is diverted from “postwar conditions” of Western Europe and the innovations said to arise from them, we find cable-stayed bridges developed well beyond the military arena of WWII to the geo-political international arena of the Cold War. While several cable-stayed bridges were built in Venezuela, Argentina, Libya and Japan from 1958 to 1972, similar bridge designs proposed and sometimes commissioned for U.S. projects were abandoned. American civil engineers’ interest and technical training in the design of cable-stayed bridges dates as far back as Steinman’s 1950 steel truss suspension bridge designed to cross the Great Belt into England with the support of cable-stays as John Roebling designed the Brooklyn Bridge built across New York’s East River in 1834 (fig. 2) but with post-WWII steel technology. Submitted to English highway officials the same year Franz Dischinger published his often cited text on cable-stayed suspension bridges,<sup>1</sup> American engineers’ engagement of cable-stayed bridge technology mirrors the trajectory towards purely cable-stayed bridges designed by their colleagues’ in the International Association of Bridge and Structural Engineers beginning in 1955.

---

<sup>1</sup> Franz Dischinger Hangebrücken für schwerste Verkehrslasten,” *Der Bauingenier*, (Berlin, Germany), 24(3), pp. 65-75 [part a], 24 (3), pp. 107-113 [part b]. David Billington and Aly Nazmy, “Aesthetics of Cable-Stayed Bridge Design,” *Journal of Structural Engineering*, Vol. 117, No. 10, (October, 1990), 3013-3034.

**Figure 2. Cable-stayed suspension bridge, Brooklyn Bridge, 1883, NY (Nikolas Jansberg)**



With no such cable-stayed bridge structures to claim for the U.S, the American community of civil engineers realized at their 1971 National Meeting on resource management for water structures that a “renaissance in bridge engineering”<sup>2</sup> was occurring beyond their national borders. The Menomonee Falls Bridge (1971), which engineers of the Wisconsin’s Division of Highways designed to provide pedestrian traffic across suburban highways, received an award earlier that year from the American Institute of Steel Construction’s Special Structures Committee. However, the recognition of a group of structural engineers with greater influence over steel construction in the European and military arenas of cable-supported structures than bridge engineering in the U.S.<sup>3</sup> is likely not the source or event that prompts this cultural awakening. Despite the technological advancements and innovative engineering concepts of structural engineers in the 1950s and 1960s, a vehicular cable-stayed bridge design was approved for construction by U.S. state highway officials for the first time in only 1970. When

---

<sup>2</sup> Walter Podolny and John Fleming, “Historical Development of Cable-Stayed Bridges,” *Journal of the Structural Division, ASCE*, Vol. 98, No. ST9 (September 1972), Proc. Paper 9201, p. 2079 (2079-2095).

<sup>3</sup> T.C. Kavanaugh, “Discussion to ‘Historical Developments of Cable-Stayed Bridges’ by Walter Podolny and John Fleming,” *Journal of the Structural Division, ASCE*, Vol. 99, No. ST7, July 1973, Proc. Paper 9826, p. 1669.

structural engineers of bridges, buildings and civil engineers convened just two years earlier, the Oregon highway division's selection of a tied-arch structure over the innovative cable-stayed bridge designs in 1964 for Portland's Fremont Bridge (1968) had conversely retained the support of their administrative colleagues.<sup>4</sup>

Disjunction between the aims of American consulting structural engineers and civil engineering managers and planners explains why Walter Podolny and John Fleming's count in 1971 of "U.S. cable-stayed bridges" includes the cable-stayed timber structures, which Podolny casts off as apart from the "modern history of cable-stayed bridges" in the U.S. This history begins with the first cable-stayed highway bridge constructed in the U.S., the Sitka-Harbor Bridge built in Alaska in 1973 rather than these typical crossings of small rivers in the rural Pacific Northwest.. In comparison to the Southern Crossing of the San Francisco Bay, which California State engineers designed in 1969 with three-dimensional tower and cable compositions (e.g. pylons and space-frame tensegrity systems) that deter from the Cartesian grid of long-span bridge engineering (fig. 3), these non-industrial structures fail to accurately represent the "state of the art" of American structural engineers' design of cable-stayed bridges at the close of the 1960s and start of the 1970s. In fact, most American civil engineers had yet to see in person or in print these structures which hark back to the first cantilevered bridge constructions built in the 17<sup>th</sup> century based upon the same stayed concept of bridge engineering (fig. 4). Accounted for but not discussed in this presentation of the "state of the art"<sup>5</sup> to their colleagues in structural engineering, these structures' sheer numbers nevertheless position the U.S. in second place behind Germany ahead of Belgium, Argentina and Venezuela in Podolny's admittedly "preliminary tally,"<sup>6</sup> revealing the geopolitical categorizations of American engineers' zeal for quantitative testament of their technological prowess's sustainment.

---

<sup>4</sup> A. Hedefine and L.G. Silano, "Design of the Fremont Bridge," ASCE National Structural Engineering Meeting, Preprint Paper No. 1210, p. 1970.

<sup>5</sup> Podolny and Fleming, p. 2709.

<sup>6</sup> Ibid., p. 2710.

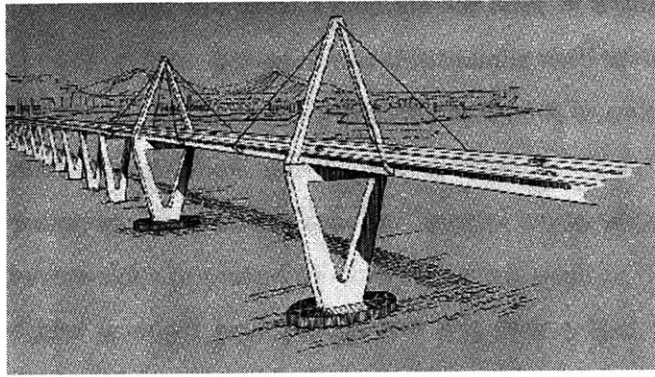

**Figure 3. Sketch for Southern Crossing of the San Francisco Bay by California Toll Bridge Authority (UC-Berkeley Collections, San Francisco Planning Dept. Records)**

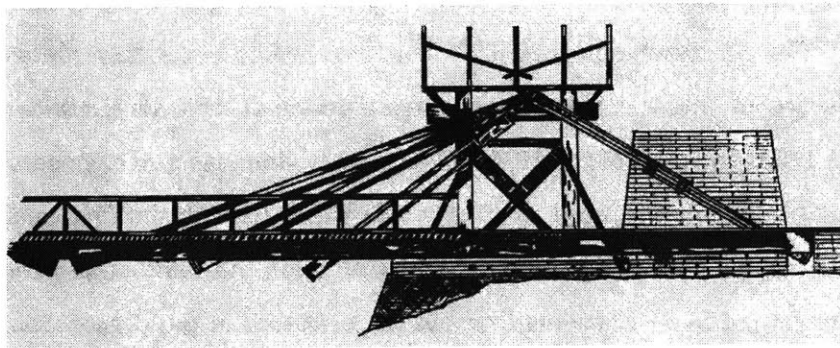

**Figure 4. An unnamed timber 'stayed bridge' by C.J. Loscher, 1784  
(Walter Podony, Jr and John B. Scalzi, *Construction and Design of Cable-Stayed Bridges*, 1986)**

## *Problem Statement*

When Fritz Leonhardt and Walter Podolny took stock of U.S. cable-stayed bridges in 1980—this time to reveal to colleagues why the Williamsburg Bridge (NY) should be replaced with a cable-stayed construction—the number of U.S. cable-stayed steel and concrete bridges had risen to 5 with at least half a dozen about to be commissioned by the state highway divisions of West Virginia, Florida, California.<sup>7</sup> Why American civil engineers' select for and constructed cable-stayed bridge designs as U.S. highway structures in the 1970s but not ten years earlier, Podolny's review of current events in American engineering of cable-stayed bridges does not address. The Conference that Podolny hosted on Cable-Stayed Bridges in 1978 as the Chief Engineer of the Federal Highway Administration provides insight into each of these events—cable-stayed bridge constructions, advancements in steel cable wiring and concrete girder standardization. Yet, the evidently changed perspective of the federal highway administration regarding the evaluation parameters for selecting one bridge type over another for U.S. highway bridge projects is not answered in this discussion of the first cable-stayed steel and concrete bridges in the U.S.

Whether the basis for comparative study of bridge types changes as more relativist theories of engineering economics and decision-making develop according to the pluralist and cyberetic structure of late-capitalist market conditions said to emerge in the following decades remains a question unanswered in these historical surveys of the state of the art.<sup>8</sup> Investigating the economics of bridge designs choices and

---

<sup>7</sup> Walter Podolny's "Cable-Stayed Bridges: A Current Review," O.H. Ammann Centennial Conference on Long-Span Bridges, *Annals of the NY Academy of Science*, Vol. 2, No. 9 (August, 1981) accounts for the same number of U.S. cable-stayed bridges identified by Fritz Leonhardt and William Zellner's "Cable-Stayed Bridges," IABSE Periodica 2/1980-IABSE Surveys S-13/80 (May 1980).

<sup>8</sup> A post-industrial turn of political and social economy (e.g. defense contracting and mass consumerism) in the 1970s, late-capitalism is a late-twentieth century revival of capitalism's ethos of competition in the political theory of emerging markets of technology and other commercial industries. This Marxist analysis of Ernest Mandel's history of political economy underscores Jean-Francoise Lyotard's theory of the "postmodern condition" in *The Postmodern*

examining the relativity of American civil engineers' evaluations. Economic historians and historians of public policy show the field 'engineering economics' for capital projects to have followed this route, but the implications of this intellectual shift beyond the rise of 'construction management' have yet to appear in published historical analyses of bridge projects or bridge designs and constructions over this period in the U.S.<sup>9</sup> Podolny and Scalzi's 1976 edition of the *Construction and Design of Cable-Stayed Bridges* offers incentives to investigate the 'economic evaluation' of cable-stayed bridge proposals in the U.S with publication of project-specific and industry-specific charts which endorse cable-stayed bridges as the most economical bridge type. Without providing any data, Podolny and Scalzi declare the number of cable-stayed bridges that were commissioned in the 1980s and thereafter to eclipse that of any other bridge type contracted as lowest bid values under the policy of 'Alternate Designs for Bridges,' that combines single-design, value engineering, and design-build contract policies adopted in the 1970s. Enacted as a Technical Advisory in 1979 and FHWA policy for all state highway divisions in 1983, 'Alternate Designs for Bridges' prescribes bridge designs that provide competition between materials, construction components and construction methods in the marketplace be selected for civic space after 'value engineering studies'

---

*Condition: A Report on Knowledge*, trans. Geoff Bennington and Brian Massumi (Minneapolis: University of Minnesota Press, 1984) as well as Frederick Jameson's theory of a "cultural logic of postmodernism" in visual and building cultures of American society in his influential text, *Post-Modernism, or the Cultural Logic of Late Capitalism* (Durham, NC: Duke University Press, 1991). Also see, the *Jameson Reader*, eds. Michael Hardt and Kathi Weeks (Oxford, UK: Blackwell, 2002). The 'free market' conditions (neo-classical Keynesian economics) of postwar economic competition in the domestic and foreign political arenas are the counterpoint to late-capitalism that both cite.

<sup>9</sup> Though initially considered by construction contractors as a means to manage subcontractors on state turnpike projects in the early 1950s, the "concept of construction management" became the primary expansion of management and business studies in the 1970s which continued the public sector analysis initiated by urban planning policy analysts. With the aid of research funding added in the federal-aid highway act of 1958 or 1967 and the university support of 'Engineering Systems Divisions' at MIT, curriculums of operations research, economic analysis and cost control at the Ivy League schools of Columbia, Harvard, Princeton, and UPenn, for instance, focused on the analytical and organizational systems influencing construction systems rather than the constructed system itself

of options in the construction industry show market competition related to these options.

Podolny and Scalzi's brief review of 'alternate designs' leaves for further research a discussion of why and when 'alternate designs' for bridges became a policy issue; from what sources the policy-making draws; and in what regards cable-stayed bridges enabled the fulfillment of objectives set by supporters in government, particularly in the state divisions of the Federal Highway Administration, in American civil engineering culture more generally, and in the international community of bridge and structural engineers. What about cable-stayed bridges or civil engineers' evaluations of these bridges allowed so-called "value engineering study" to yield competitive bridge designs of the cable-stayed bridge type? What about value engineering studies allowed designs of the cable-stayed bridge type to be endorsed for construction? This thesis addresses these questions by examining bridge type selection in the theoretical and social practices of value engineering study that play a role in bridge projects of the period preceding these years of focus in Podolny and Scalzi's texts.

A discussion of economic value and bridge selection immediately raises the question of where 'engineering economics' as a subject of study falls within this historical study and other discourses. In engineering history as well as architectural and planning scholarship on bridge projects, specifically the selection of one design over another, engineers' evaluation of designs is typically treated as rational by default, with the extent to which "rational economics suggests deterministic technological development"<sup>10</sup> left unexamined. With every military move of the Cold War, economic theories concerning industry and economic development shifted focus and principles, yet the economic limits, principles of evaluation and methods of valuation by which civil engineers justified their design proposals continue to be articulated in historical

---

<sup>10</sup> Gerald A. Fleischer, preface, *Risk and Uncertainty: Non-deterministic Decision Making in Engineering Economy*, Engineering Economy Division Monograph Series No. 2 (Norcross, GA: American Institute of Industrial Engineers, Inc., 1975).

analyses as the same as that of preceding generations. In the years spanning 1942 and 1972, the field of 'engineering economics' expanded beyond the macroeconomics of input and output costs, materials, and labor to include the new practices of economic analysis, namely economic forecasting of postwar and 'Third World' technological development; creation of game-theoretical equilibriums in economic marketplaces; and total and life-cycle cost analysis of designs' conception, production, construction, maintenance and demolition. Each of these types of 'end-games' for design decision-making<sup>11</sup> are considered pertinent to study of these structures, which are selected for construction as the Vietnam War comes to a close.

Podolny and Scalzi's 1976 edition of the *Construction and Design of Cable-Stayed Bridges* offers incentives to investigate the 'economic evaluation' of cable-stayed bridge proposals in the U.S.<sup>12</sup> With publication of project-specific and industry-specific charts which endorse cable-stayed bridges as the most economical bridge type but no statistical data, Podolny and Scalzi declare the number of cable-stayed bridges that were commissioned in the 1980s and thereafter eclipse that of any other bridge type contracted as lowest bid values under the policy of 'Alternate Designs for Bridges,' which combines single-design, value engineering, and design-build contract policies adopted in the 1970s. Enacted as a Technical Advisory in 1979 and FHWA policy for all state highway divisions in 1983, 'Alternate Designs for Bridges' prescribes bridge designs that provide competition between materials, construction components and construction methods in the marketplace be selected for civic space after "value engineering studies" of options in the construction industry show market competition related to these options.<sup>13</sup>

---

<sup>11</sup> Felicity Scott, "End Games and Outer Limits," Myriam Bellazoug Lecture, Yale School of Architecture, Hastings Hall, New Haven, CT, Nov. 8, 2004.

<sup>12</sup> Walter Podolny, Jr. and John B. Scalzi, "Chapter 3: Economic Evaluation," *Construction and Design of Cable-Stayed Bridges* (New York: John Wiley & Sons, Inc., 1986).

<sup>13</sup> "Alternate Design for Bridges: Policy Statement," Federal Register, Vol. 48, No. 93, p. 21409 (Thursday, May 12, 1983; Federal Highway Administration Docket No. 82-17, Notice 2).



Podolny and Scalzi's brief review of 'alternate designs' leaves for further research a discussion of why and when 'alternate designs' for bridges became a policy issue for bridges; from what sources the policy-making draws; and in what regards cable-stayed bridges enabled the fulfillment of objectives set by supporters in government, particularly in the state divisions of the Federal Highway Administration, as well as American civil engineering culture and the international community of bridge and structural engineers. What about cable-stayed bridges or civil engineers' evaluations of these bridges allowed so-called "value engineering study" to yield competitive bridge designs of the cable-stayed bridge type? What about value engineering studies allowed designs of the cable-stayed bridge type to be endorsed for construction? This thesis addresses these questions by examining bridge type selection in the theoretical and social practices of value engineering study that historically frame bridge projects in the years preceding those of focus to Podolny and Scalzi.

## *Overview of Thesis Study*

This thesis seeks to examine cable-stayed bridge selections for highway bridge projects of this period from two distinct perspectives of architectural studies of technology: a) social history of bridge selection theory in the political discourse on U.S. highway building post-1968; and b) critical study of cable-stayed bridge designs selected for bridges ultimately constructed in the late 1970s. Cable-stayed bridge selections made in the preliminary stages of highway projects possess no finite form of construction to accurately estimate cost; nor do these selections made prior to design commission embody a precise arrangement of technological components relative to the site to justifiably state a design's constructability. This thesis thus qualitatively discusses how the schematic form and open-ended (or indeterminate) state of structural design that possess little longevity in master building of highway structures in the 1960s hold value in the context of 1970s cost, project and value control objectives infiltrating the political and professional culture of federal highway administration.

This cultural history presents the cable-stayed bridge designs selected during this period of 1969 to 1979 as one instance of American civil engineering culture adapting to major bridge projects the economically measured but industrial approach to choosing, reconfiguring and eliminating construction systems of value engineering. Also called 'value control,' value engineering's decision-making methods of evaluating designs for structures relative to the current functional criteria and future economic objectives of development structures within the sociotechnical interstate highway system are presented as only one side of a historical phenomenon which includes more political means of regulating public architecture, the industrial products of defense and public works corporations and other types public and private infrastructure. The shift in cable-stayed bridge designs' fate evidenced by successive bridge constructions of that type in the later 1970s depends, I contend, on the civil engineering culture's adoption of value engineering methods of systems building and creative engineering to subjectively figure as supposed to objectively define feasibility of the cable-stayed concept of

construction in a sociopolitical language not unlike that of socialist manifestos for architecture by Russian constructivists Antoine Pevsner and Naum Gabo in the 1920s. A discussion of these analytical and conceptual frameworks for bridge design that employing value engineering theories of multi-value postwar technological systems, this study of cable-stayed bridges expands the implications of historical works on post-industrial scientific thought and design practices in architectural culture of the Cold War period that shed light on the impact of economics, systems and operations theory on structures' design.<sup>14</sup>

This thesis focuses on the historical development of value engineering concepts of construction as they apply to highway bridge administration and preliminary bridge design studies in the midst of volatile economic conditions caused primarily by the Vietnam War (1967-1972) and the OPEC Oil Embargo of 1973. As an adaptive technological plan for building a highway bridge system of construction systems relevant to economic industry competition and 'market moves,' the economic status of bridge constructions in this discourse as a social medium and analytical mechanism that opens doors to plural economic scenarios of design competition for the highway administration not just a case of lowest cost design selection. Only as such competitive alternate designs of the same overall mechanism of bridge construction, not as alternative designs of a bridge typology, do the high-capital long-span bridge designs of the Luling Bridge (LA, 1978) and the Pasco-Kennewick Bridge (WA, 1977) develop into physical constructions built almost exclusively with federal highway funds.

Chapter 1 presents the political discourse of the Federal highway Administration, the Society of American Value Engineers and the Transportation

---

<sup>14</sup> Reinhold Martin, *The Organizational Complex: Architecture, Media and Corporate Space* (Cambridge, MA: MIT Press, 2003); Howard P. Segal, "Progress and Its Discontents: Postwar Science and Technology Policy," Harvey M. Sapolsky, "The Science and Politics of Defense Analysis," and "Introduction: The Social Sciences, the Federal Government, and the Age of Postmodernism," *The Social Sciences go to Washington: The Politics of Knowledge in the Postmodern Age*, ed. Hamilton Cravens (New Brunswick, NJ: Rutgers University Press, 2004); Felicity Scott, "End Games and Outer Limits," Myriam Bellazoug Lecture, Yale School of Architecture, Hastings Hall, New Haven, CT, Nov. 8, 2004.

Research Board's Commission on Sociotechnical Systems on project, cost and value control in the short period preceding the subsequent selection of cable-stayed bridge construction schemes. Discussing their objectives in the case of the Interstate 410 Luling and Chalmette Bridges and major highway bridge structures in general, this cultural history of value engineering's pluralist and market competition concepts of construction systems building (or 'creative engineering' in VE rhetoric) and feasibility of preliminary designs (or 'value analysis' of a design's project costs) provide the historical context and theoretical framework for further examination of highway bridge type selection circa 1969.

critical studies of the open-ended process of composing designs of the cable-stayed 'bridge type' and the non-deterministic trajectory proceed In Chapter 2 for cable-stayed bridge designs proposed and made project selections through value analysis of bridge projects' economic and functional costs in current and future scenarios of industry competition Focusing on the preliminary design studies of Arvid Grant and Fritz Leonhardt for the Pasco-Kennewick Intercity Bridge project (1972-3),<sup>15</sup> this examination of speculative industry data for steel and concrete bridge constructions questions the validity of feasibility assessments articulated for cable-stayed bridges and evaluates how value engineering of highway bridge constructions becomes an indivisible component of civil engineers advancing the efforts to achieve value control..

---

<sup>15</sup> Arvid Grant founded and led Arvid Grant and Associates (Olympia, WA) at the time as did Franz Leonhardt for his firm, Leonhardt and Andra Partners (Stuttgart, Germany).

## Literature Review

Besides Podolny and Scalzi's brief reflection on the political literature on value engineering, there is no written history of value engineering in civil engineering culture with which to refer. Theoretical analyses of value engineering's application on infrastructure projects from the perspective of construction business history are plentiful, however.<sup>16</sup> Even today, in the *Harvard Business Review* and the *Business History Review*, construction planning concepts greatly affecting architecture and planning projects, namely FAST-tracking or 'functional analysis systems techniques' for project scheduling, play a primary role in proving the effectiveness and historical significance of value engineering methodology.<sup>17</sup> Written in the 1970s and '80s in the midst of value engineering and management being imposed upon the U.S. construction industry, the "evolution and history of VE" reflects upon who—which agencies and companies—and what—the value analysis and engineering programs—but not why the

---

<sup>16</sup> Few focus on bridge projects. For studies pertaining to highway and public works projects, see Pamela Bloomfield, David Westerling and Robert Carey "Innovation and Risk in a Public-Private Partnership: Financing and Construction of a Capital Project in Massachusetts," *Public Productivity & Management Review*, Vol. 21, No. 4.(Jun., 1998), pp. 460-471. The introduction to *Nondeterministic Decision-making in Engineering Economy*, ed. Gerald A. Fleischer (Norcross, GA: American Institute of Industrial Engineers, Inc., 1975) offers a historical and intellectual cross-section of the concepts discussed in much of this literature focusing on economics of engineering management practice. Manuel C. Macedo, Jr., Paul V. Dobrow, Joseph J. O'Rourke's *Value Management for Construction* (New York: John Wiley & Sons, Inc., 1979) surveys such work's significance to civil construction in the public and private sectors.

<sup>17</sup> For instance, in "Modular architectures in the Marketing Process," *Journal of Marketing*, Vol. 63, Ron Sanchez discusses how the modular product architectures of value engineering's theory of marketing are adopted in a growing number of markets, including construction. The paper compares to conventional marketing processes the modular product, process, and knowledge architectures that enable firms in these different markets to create greater product variety, introduce technologically improved products more rapidly, bring new products to market more quickly, and lower costs of product creation. Also see Richard D. Conner's "Contracting for Construction Management Services," pp. 5-23, Milton F. Lunch's "New Construction Methods and New Roles for Engineers," pp. 83-94, and Stanley D. Bynum's "Construction Management and Design-Build/Fast Track Construction from the Perspective of a General Contractor," pp. 25-38, in *Law and Contemporary Problems*, Vol. 46, No. 1, (Winter, 1983).

“value concept” became a part of design and construction management. Furthermore, the value engineering policy-making of the U.S. Senate Committee on Public Works between 1966 and 1983—including a non-binding resolution, mandatory clauses in highway aid packages, legislation requiring value engineering provisions in every transportation-related project, and even a bill proposing a Value Engineering Act—has yet to become the subject of historical study in political science. Thus, the fact that engineers reflecting upon cable-stayed bridge projects of the 1970s and ‘80s considered value engineering policy to have an influence over American engineers and administrators’ evaluation of bridge designs is even more significant.<sup>18</sup>

The design of built structures within the historical and socio-cultural contexts of value engineering remains a non-issue in almost all references on value engineering, except the few on the construction industry. The seminal text on value engineering’s application to the design, contracting and management fields of the construction industry, *VE in the Construction Industry*, by A. Dell’ Isola, has descriptive content and an instructional tone with few critical reflections upon the development’s influence over designs’ compositional, technological or conceptual changes. Ironically, value engineering began as a technique of analyzing and redesigning original schemes, specifically for electronic and steel arms mechanisms, such that designers’ corporate entities would meet purchasing parameters dictated by production and deployment schedules set by the U.S. defense departments. Developed by Lawrence Miles at General Electric during WWII while he practiced as a design engineer of protective tubing for triggers and then as a manager for GE’s purchase of steel tubing, these techniques proved to army and navy colonels that contractors could save the government money and/or increase their own profits by redirecting design reviews towards evaluating just how functional systems’ functionality proved relative to ‘field operations’ and the life of arms’ operation. “How can [we] provide [those products’]

---

<sup>18</sup> Podolny and Scalzi, *Construction and Design of Cable-Stayed Bridges* (New York: Wiley and Sons, Inc., 1986), p. 36.

function by using some machine or labor or material that *is* obtainable?”<sup>19</sup> Miles first asked in 1944 upon realizing that the U.S. steel Industry was unprepared to meet the challenge of transitioning from commercial goals of organizational profit schemes to war productivity schemes. Design had involved producing a schematic that worked based upon past practice, but according to his supervisor in the new position of Chief Operations Officer, designers would in wartime and post-war conditions have to reevaluate the value of such ‘tried-and-true’ schematics in terms of which goods and services then available from technology industries met the organization’s cost goals.

Though knowledge in the field of value engineering was rapidly generated between 1947 and 1972, when Lawrence Miles first worked out the techniques of value analysis and when he republished them as one component of value engineering, the methodology and training of value engineering (VE) did not change appreciably during this period. A typical conversation with a dean of academic affairs consequently revolved around the question, “What’s the difference between value engineering and engineering as it is taught here, which includes engineering economics and cost analysis?” The realization that VE was an “intriguing combination of physical and social sciences”<sup>20</sup> informed by courses in business economics, cost control methods, industrial psychology, and creative problem solving invariably prompted wonder as to why the label “value engineering” was chosen as the “suitable professional title” and not something that expressed “how much broader it [was] than engineering.”<sup>21</sup> Although SAVE officials like C. Fallon understood that value analysis was the most acceptable

---

<sup>19</sup> Maunel C. Macedo, Jr., Paul V. Dobrow, Joseph J. O’Rourke, *Value Management for Construction*, Construction Management and Engineering Series, ed. John F. Peel Brahtz (New York: John Wiley & Sons, Inc., 1978), p. 3.

<sup>20</sup> Carlos Fallon, “Body of Knowledge Underlying the Value Disciplines,” *Proceedings of the SAVE Conference--1971* (Washington, D.C.: Spartan Books, 1971), vol. VI, p. 22. The conference was held in Miami, Florida, May 24-26, 1971 by the Society of American Value Engineers (SAVE) for their annual National Convention.

<sup>21</sup> *Ibid.*

“label’ for “what value engineers do to value,”<sup>22</sup> the term ‘value engineering’ pointed to the cultures of civil engineering and industrial engineering which value engineers sought to affect with their philosophies, methodologies, techniques and policies—and also the culture with which they belonged.<sup>23</sup>

In 1967, the ideological foundation for the twenty-year-old Society of American Value Engineers (SAVE) would be celebrated with colorful language by more than a few engineers, but their grandiose claims are justified by the imprint of value engineers on the analysis of designs with a relationship to industry and markets—essentially all design fields at some stage of their cultural production. Proving that Miles’ techniques of value analysis and engineering “really worked,” case studies of savings due to engineering corporations’ participation in the DoD’s VA/VE programs and establishment of their own programs suggested that value engineering was no longer a technique of industrial management but rather a methodology of the engineering disciplines employed by civil servants concerned with value. It could then also serve to acculturate communities of engineers in civil service concerned with prevailing government and community values concerning public administration of transportation, environmental facilities and public architectural and engineering structures. Value engineers would consequently situate their community and practice more profoundly,

*Amidst “this day of the ‘organization man,’ excessive conformity and the chief cult, all passed upon passé tribal thinking,” value engineering arises as “another dynamic, typically American revolution, [that] is an industrial-intellectual reformation, a program which because it places a cost on curbing conformity and organizational constraints, provides purpose, plans,*

---

<sup>22</sup> Ibid, p. 22.

<sup>23</sup> Ibid, p. 19-20.



*and promise for optimizing group creative behavior” (1966 SAVE Conference).*<sup>24</sup>

The condemnation of Theodor Adorno’s social typology of character ‘typed’ postwar engineers losing their individual capacity to make decisions based upon creativity rather than conformity finds its way from William H. Whyte Jr.’s popular social criticism, *The Organization Man* (1956), to value engineering historiography for a new generation of value engineers concerned with socially engineering “value engineering thought” versus creating corporate VA/VE programs.<sup>25</sup> Leaders of the Society of American Value Engineers had learned from their attempts in the early 1960s to create an organization man out of every industrial designer that design teams must be acculturated in the principles of value engineering before the value engineering program and policy of their organization was to be practiced. Many of the VA/VE programs established in design departments of AT&T, Westinghouse and General Electric exploited the back door that administrators of projects offered to the practice and community of designers only to find that neither the tools and mechanisms of procurement, which purchasing departments used, nor the policies and procedures of management, proved relevant to design. With “VE philosophy” defining functionality not just function for the organizational structures of social as well technical systems, the basis of value engineering could be defended and, like a science, expanded in application, it was argued in 1971 by new SAVE members from social anthropology, sociology and management. Without any intended industry or mode of practice, this “value

---

<sup>24</sup> Thomas F. Cook, “Value Engineering and the Third Revolution,” National Conference of the Society of American Value Engineers held in Chicago, Illinois, May 13-16, 1973, SAVE Proceedings, vol. VI, p. 15.

<sup>25</sup> Reflecting upon the last 10 years, Cook comments on the decline of VA/VE programs established in the 1970s versus the twenty years prior. He anecdotally contributed the shift to a focus on technological versus industrial management, specifically the “third revolution of scientific management” in the social application of industrial engineering concepts and strategies. In the midst of the debate in 1969, the disparate agendas are surveyed in, Arthur Harvey, Jr.’s “What makes Value Engineers?” National Conference of the Society of American Value Engineers held in, May 24-26, 1971, SAVE Proceedings, Vol. 6, pp. 26-36.

engineering methodology” for creating physical, analytical and social constructions of value lacked the fundamentalism that gained Miles’ “Value Engineering System” a patent in 1947.<sup>26</sup> On the other hand, the fact that the “value concept”<sup>27</sup> would only in retrospect become clear in each field of application, allowed value engineering to transform with the politics of its application into a social theory of its own.

## *Methodology*

Arguments on the entanglement of value managers’ methods of analysis and design and civil engineers’ rating and comparison of bridge design alternatives relies upon comparing the diverse visual and analytical, descriptive and quantitative data regarding the philosophy and methodology of value engineering, engineering economics, and transportation design selection. Found in all of these subjects’ various cultural incarnations of value analysis, value engineering, and value management, ‘project control,’ ‘cost control,’ and ultimately ‘value control’ yields the mathematical and decision-making models for bridge types’ economic and functional value to this historical period. Less technical and more descriptive of the aims or principles of value engineering policies, studies and demonstration projects, these concepts and terms from the VE discourse provide evidence of how designers did not necessarily have to buy into the doctrine of value engineering but merely identify with the principles or standards for applying value engineering “thought” in their specific professional contexts.

The potential for value engineering to merge with other post-modern languages of design and theories of structure was only a matter of time come its introduction

---

<sup>26</sup> The patent number for this so-called “system” could not be determined from conventional patent records. Macedo, et. al. assert this patent’s date as 1947 in *Value Management for Construction* (New York: John Wiley & Sons, Inc., 1978). Lawrence Miles’ discussion of this “Value Engineering System” as a formal entity recognized in 1947 in *Techniques of Value Analysis and Engineering, 2<sup>nd</sup> ed.* (New York: McGraw-Hill, 1972),p. 101 corroborates the existence and year of this patent approval.

<sup>27</sup> Macedo, et. al., p. 5.

structural engineers, architects and construction managers of American civil engineering culture. With terms like ‘morphological decomposition’ proposed by a doctoral design student of University of Waterloo replacing ‘breakdown analysis’ in value engineers worksheets on functional analysis in the construction industry, value engineering fit itself to the rhetorical and professional ideas of architects and engineers of the planned and built environment.<sup>28</sup> This thesis investigates this merger of practices and ideologies through a type of bridge construction as it comes into its own alongside the civil engineers’ navigation of this new world of selecting valuable bridges not just the state-of-the-art of their discipline.

My understanding of infrastructure decision-making is drawn from original documents on state and federal procedures for bridge projects as published in the *Federal Register* and the numerous editions of the *Federal-Aid Highway Manual* or accounted in state divisions’ online historical archives regarding bridge projects of various types. The social mechanisms that figure into conceptual and even representational aspects of government-employed and consulting engineers work depends upon the case, which for this thesis are the Pasco-Kennewick, East Huntington, Luling and Sitka-Harbor Bridges. However, the ‘social studies’ of civil engineers by Seeley (1990, 1996), Latham (2000) and Galison (2003) also inform interpretations of these relationships.<sup>29</sup> Because not only structural engineers concerned with bridge designs

---

<sup>28</sup> S.F. Love, “A New Approach to Value Engineering from Cultural Anthropology,” Doctor of Design Candidate, University of Waterloo, *SAVE Conference—1969*, Washington, D.C., Vol. 3, p. 109 (108-114).

<sup>29</sup> Bruce Seeley, “Changing Patterns of Research in American Engineering Colleges: The Social Dimension of the Rise of Engineering Science,” in Bart Gremmen, ed., *The Interaction between Technology and Science* (Wageningen, The Netherlands: Wageningen Agricultural University, 1992), pp. 159-81; Bruce Seeley, “State Engineers as Policymakers: Apolitical Experts in a Federalist System,” in Jerry Rogers, et. al., editors, *Civil Engineering History: Engineers Make History*, Proceedings of the First National Symposium on Civil Engineering History, held at the Annual Meeting of the American Society Civil of Engineers, Washington, DC, November 10-14, 1996 (New York: ASCE, 1996), pp. 123-35. Michael E. Latham, *Modernization as Ideology: American Social Science and “Nation Building”* (Chapel Hill: Univ. of N. Carolina Press, 2000); Peter Galison, “The War on Space,” *Architecture and the Sciences Exchanging Metaphors*, eds. Antoine Picon and Alessandra Ponces. (New York: Princeton Architectural Press, 2003).

were involved in the design or construction of bridges or the meetings of the ASCE committees, I have cast the net beyond disciplinary ASCE publications. Using social histories of civil engineers as a guide, I include magazines, manuals, instructional book-length texts, industry and business journals, and institutional or corporate newsletters that capture engineers' research, project administration and industrial planning. Such *intra-cultural* exchange provides the context for 'American civil engineering culture,' to which I refer throughout this study.

Because this thesis' conceptual framework for 'engineering theory' claims the application of knowledge in professional practice extends beyond conventional mechanical and natural notions of engineering science, I have looked to unconventional sources and interdisciplinary methods of research to study and present a cultural history and critical study of cable-stayed bridges in American civil engineering culture. Proposing 'engineering theory' during the period of study to involve design theories or theories of engineering in a particular cultural or social context, I examine the design methods, social science and cultural theory often implicit in feasibility studies for bridge projects,<sup>30</sup> studies of preliminary and detailed designs, and bid documents used for the solicitation of construction contracts. Unfortunately I was unable to acquire many projects' original documents. Analyses thus derive from first- and second-hand accounts in conference paper pre-prints and journal articles by the studies' authors as well as oral accounts from officials formerly involved in the projects or development of the areas. With this perspective on American engineering media and discourse, I recognize that forms of cultural production and members of both the public and private sectors of society besides civil, structural and bridge engineers play a role in the formation, reconfiguration and representation of engineering design concepts and structures' history.

---

<sup>30</sup> For instance, social integration, which framed labor and resources management for highway and bridge construction following application of the Brown v. Board of Education ruling to federally-aided transportation projects.

Derived primarily from engineers' discourse on bridges, this study of cable-stayed bridges diverges considerably from the traditional disciplinary approaches to historical developments in civil engineering cultures. Typically these studies veer into construction and industrial history for insight into innovation and peer into architectural and art discourse for insight into aesthetics. This study looks to economic and political history for insight into designs' perception outside civil engineering communities in the field of infrastructure and the industry of construction. Instead of drawing upon social theory of intercultural exchange, which sets the comparative frameworks for Gregory Dreicer's studies of bridge design on both sides of the Atlantic in the 19<sup>th</sup> century and during WWII, or the social science of comparative design studies employed by Eda Kranakis to analyze the social influence and cultural significance of American and French civil engineering communities of 19<sup>th</sup> century, this thesis follows the humanistic approach of Richard Scott's recent study of aerodynamic stability at the center of suspension bridge design post-1949.<sup>31</sup> The cultural studies of all of these historical works have helped to demystify the notion that engineering communities possess the capacity to isolate themselves from social theory and cultural theory of their time while maintaining stable and coincident relationships with the social conditions through the progress of their work from concept to completion. By replacing dialectical social theory of human conflict over designs with a historically relevant cultural notion of competition between bridge design concepts and construction systems and highlighting the significance of preliminary designs and bridge type selections in infrastructure planning of the 1970s, I offer cultural narratives as another means to understand the relationship between historical force and cultural context in engineering history.<sup>32</sup>

---

<sup>31</sup> Gregory K. Dreicer, *The Long Span. Intercultural Exchange in Building Technology Development and Industrialization of the Framed Beam in Western Europe and the United States, 1820-1870* (Ph.D Dissertation, Cornell University, 1993). Eda Kranakis, *Constructing a Bridge: an exploration of engineering culture, design and research in 19<sup>th</sup> century France and America* (Cambridge, MA: MIT Press, 1997). Richard Scott, *In the Wake of Tacoma: Suspension bridges and the Quest for aerodynamic stability* (Reston, VA: ASCE Press, 2001).

<sup>32</sup> The most recent historical study of cultural developments in civil engineering centered about cable-stayed bridges (David Billington and Aly Nazmy) is also based upon this premise, but as a

## Chapter 1: VE and the Value Control of U.S. Highway Bridge Projects

*“Construction is a pluralistic endeavor with involvement by both the private and public sectors...With our construction dollars buying less, alternative engineering methods which reduce project costs must be encouraged...”*

~ Senator Jennings Randolph (WV), Introduction to the “Resolution on VE,” Senate Committee on the Environment and Public Works, May 12, 1977

Meeting with federal officials at the now famous Airlie House Conference Center in a Virginia suburb of D.C., social scientists of decision-making convened with ethnic minorities from highway-dense urban neighborhoods—an African-American woman from the Los Angeles Watts area and a working-class Polish homeowner from Rochester, NY, a Jewish civil-rights activist and the first black mayor of Newark, NJ—to make up the eclectic mixture of “individuals affected by civil engineering decisions.”<sup>33</sup> Awkwardly sitting in a room integrated in terms of race for the first time since the last conference on Transportation and Community Values was held, the public symbol of President Kennedy’s meetings on integration offered a safe haven for all to weigh in on how the infrastructure community could create alternative highway selections that would remain viable to the public over time and in multiple value systems. “The outcome of any system must be of value to the next higher system of which it is a component,”<sup>34</sup> Jeffrey Wiegand, explained as he marketed his books *Value Engineering*

---

paper-length study its references to cultural discourses on the aesthetic concerns of reconstruction held by major players of the pre-WWII German Aesthetics Movement and formalism in German structural engineering education rely upon arguments put forth in Billington’s other works about aesthetics’ role in bridge design competitions.

<sup>33</sup> “Morning Session Discussion Highlights, *Transportation and Community Values* (Washington, D.C.: Transportation Research Board, 1969), p. 145.

<sup>34</sup> Jeffrey Wiegand, *Ibid*, p. 155. Weigand’s texts *Value Engineering and Cybernetics* (1969) and *Value Analysis and General Systems Theory* (1970) are not only no longer in print or major library collections. The publication dates for these books could only be found in a periodical notice

*and Cybernetics* (1969) and *Value Analysis and General Systems Theory* (1970) to be published later in the year. The ‘urban problem’ of highway constructions that were not adaptive to these citizens’ community values may have been “the problem of the urban crisis”<sup>35</sup> consuming the morning discussion, but surely mismanagement of private investment in metropolitan development, had transformed the public financial crisis of imbalanced private sector investment in urban development into a national problem of resource management for highway development.

With selection standards for bridges aligned with decision-making standards for highways built amidst the uncertain conditions imposed by inflation, community values and environmental factors, the ‘organization’ of Interstate builders could more than redeem itself through adoption and application of a new organizational value system. Such “restoration of humanity,”<sup>36</sup> as declared in William Whyte’s *The Organization Man* (1956) and the Department of Transportation Act of 1967,<sup>37</sup> required that only non-Aristotelian systems of knowledge and the boundless semantics of cybernetic thinking (e.g. multitasking, networking and simultaneous comparison of ideas)<sup>38</sup> would produce the self-reflection and creativity in civil engineers necessary for the “integrated and efficient transportation system.”<sup>39</sup> Epitomized by the commission of a single bridge designer, design, construction and contractor for each highway bridge project, the single-mindedness of highway building and civil engineers’ problem-solving strategies revealed a need for value engineers beyond the relatively small quantity identified by

---

discussing the agenda for industrial engineers’ attendance at federal transportation conferences in *Operations Research*, Vol. 12, No. 5 (Aug 1964), pp. 801 (801-804).

<sup>35</sup> Roger Creighton, Introduction, *Transportation and Community Values*, p. 7.

<sup>36</sup> President Robert F. Kennedy, as quoted in the preface to the *Department of Transportation Act, 1967* (Office of Government Printing, 1967). Also see the introduction to William Whyte’s *The Organization Man* (New York: Simon & Schuster, 1956), pp. 1-4.

<sup>37</sup> Ibid.

<sup>38</sup> See Russell Meyer’s preface to *Science and Sanity: an introduction to non-Aristotelian systems and general semantics*, 4<sup>th</sup> ed. (Lakeville, CN: International Non-Aristotelian Library Co., 1957),

<sup>39</sup> President John F. Kennedy signed this phrase “integrate and efficient transportation system” into law with the Department of Transportation Act, preface *Department of Transportation Act of 1967* (Washington, D.C.: U.S. Government Printing Office, 1967).

“Who is a Value Engineer?,” one of the personality tests infamously conducted in 1967 prior to the Senate Committee on the Environment and Public Works’ hearings on value engineering.<sup>40</sup>

Through policy-making, public representatives supported systematically and expeditiously extending to civil construction agencies a multi-valued system of thinking built upon a Value Analysis and Engineering Program like that already in use by the Departments of Defense and the Interior.<sup>41</sup> The Department of the Interior’s Armed Services Procurement Regulation (ASPR) for civil construction agencies drafted the first comprehensive political treatment of value engineering in 1962 to establish a path for the value discipline to travel across the line between public and private sector society, military and civil engineering, corporate complexes in Alexandria, Virginia and government headquarters in Washington, D.C.<sup>42</sup> Reissued in January 1969 with additional incentives for industry’s participation in value engineering as well, the ASPR procedures for function and cost analysis on all construction projects exceeding \$100,000 in initial cost institutionalized the goals of value control—to develop policy content through project and cost control and industry and government cooperation.<sup>43</sup> Concluding that value engineering (VE) is a technique of “creative behavior” and “systematic exploration” of new materials and methods of the construction industry,<sup>44</sup> these financial provisions for construction versus architect-engineer contractors suggest congressmen expected the ‘market moves’ of industry to pick up the front end of total

---

<sup>40</sup> Louis C. Kingscott, Jr., “The Construction Industry and Value Engineering,” SAVE Conference, 1969, p. 82.

<sup>41</sup> See the *Proceedings from the Public hearings on the application of value engineering of the U.S. Senate Committee on Public Works and the Environment* (Washington, D.C.: U.S. Government Documents Office, 1967).

<sup>42</sup> Macedo, p. 8. Reprinted in Appendix A of A. Dell’ Isola’s *VE in the Construction Industry* (pub) is the full text of this policy statement’s 1972 edition.

<sup>43</sup> EPA’s “Program Guidance Memorandum No. 63” (January 20, 1976). Also see, GAO report to the U.S. Congress, “Potential of Value Analysis for Reducing Waste Treatment Plant Costs” (May 8, 1975).

<sup>44</sup> ASPR regulations for value engineering published in Alponse Dell’Isola’s *Value Engineering in Construction Industry* (New York: Construction Publication Co., 1974), Appendix II.



costs incurred from their elevating social contracts for construction to the metaphysics of “building designs (not specific to buildings).”<sup>45</sup>

West Virginia congressman Jennings Randolph, author also of the Senate Committee’s 1973 “Resolution of Value Engineering,” had no solutions or methods for how a transition from “mere exploration of new technology”<sup>46</sup> for preliminary designs to perceiving new technology as *the* preliminary designs would occur. Nonetheless, a Bridge Replacement Program would help FHWA officials finance “any means necessary to take advantage of its benefits,”<sup>47</sup> including the hire of value engineers in state divisions as well as the federal divisions of the Department of Transportation. In his and his colleagues’ zeal for cost savings to quench the dearth of capital for urban development and government services, Randolph ironically chose the same turn of phrase, “any means necessary,” that Malcolm ‘X’ Shabazz was popularizing in his rally speeches against further highway building through the boundary neighborhoods that value engineers called “wastelands of unfunctional construction systems.”<sup>48</sup>

Use of the ASPR regulations and DOD procedures as guidelines for redefining the social ethic of teamwork in creating a highway system valued by various sectors of American society begins almost immediately with a number of conferences and symposiums in 1969 funded by the Transportation Research Board and hosted by its liberal think tank, the Commission on Sociotechnical Systems. Alan Altschul, MIT behavioral scientist for the Highway Research Board and Commission board member opened the Conference on Transportation and Community Values held in May 1969 with an agenda to explore how value analysis could be adopted in every phase of

---

<sup>45</sup> Ibid.

<sup>46</sup> Jennings Randolph, preface to *U.S. Senate Resolution on Value Engineering, 1973*, as reprinted in *Macedo, et. al.*, p. 19.

<sup>47</sup> Federal Highway Administration “Bridge Replacement Program,” *Federal Register*, Vol. 47, No. 201 (Monday, Oct. 18, 1982), pp. 21409.

<sup>48</sup> Lawrence Miles, *Techniques of Value Analysis and Engineering* (New York: McGraw-Hill, 1972), p. 314.

project selection, not just engineering, per se.<sup>49</sup> Assuring the community representatives at the Airlie House Conference Center (VA) that “inventiveness and creativeness of the sponsoring organization are the only real limit to the form and extent of alternatives”<sup>50</sup> it would appear Alan Altschul attaches value engineering’s theory of “creative behavior” to his own research on the liberal ideology of rebellion against and conflict with status quo in innovative engineers of corporations with vertical integration structures.<sup>51</sup>

Drawn from Altschul’s research and the work of other consultants to analytical operations at General Electric, Westinghouse, AT&T and IBM between 1963 and 1969, a less rigid and more equitable “value system”<sup>52</sup> of highway construction could more than embody the strategic planning of new decision-making processes in civil engineering culture. The cybernetic part-whole relationship between planning and engineering that develops through organizational “restructuring”<sup>53</sup> into these product-focused social structures positions the schematic profile of Chicago expressway bridges discussed at the conference in both the social and technical decision-making planes of highway

---

<sup>49</sup> Alan Altschul, “Operations Research Applications to Transportation Decision-Making” in *Transportation and Community Values*, p. 49.

<sup>50</sup> Ibid.

<sup>51</sup> Ibid, pp. 15-21. Altschul’s research in this area can be found in case studies such as *Phillips: a study of the corporate management of design* (1989), which describes systematic planning that Frans van der Put instituted at Phillip as the first house “style manual” in 1965. As such it gave consistency to all aspects of the company’s products by promoting “design must prove itself by its works.” Appearance design, as it was called, could not only entice a consumer to buy, but formulate a style for products slightly different in form that represents the company brand. The liberal ideology of rebellion against and conflict with status quo in innovative engineers mentioned here is the focus of Alex Osborn’s analysis of Altschul’s work as it pertains to professional practices outside operations research, which is the perspective from which this paper looks at theories of behavioral science and psychology for civil engineering and bridge type selection more specifically. See Alex Osborn, *Applied Imagination: Principles and Procedures of Creative Thinking*, 3<sup>rd</sup>. rev. ed. (New York: Scribner, 1979), p. 52.

<sup>52</sup> Alan Altschul, p. 49.

<sup>53</sup> Comparing horizontal and vertical architectures of industrial engineering corporations such as IBM and AT&T, which Reinhold Martin’s discusses in Chapters 3 (“The Physiogomy of the Office”) and the Chapter 5 (“Computer Architectures”) in *The Organizational Complex: Architecture, Media and Corporate Space* (Cambridge, MA: MIT Press, 2003), with [Author’s], *Phillips: a study of the corporate management of design* (1989), it becomes clear that structuralist theory of organization and exchange underscores the thesis of cultural exchange between the analytics and composition of both architecture and engineering structures.

building culture. Straddled across these distinct disciplines, bridge designs consistently selected by and for a socially integrated highway system allow the Highway Research Board to remove hyphenation from the term 'socio-technical systems' in their discussion of the urban transportation network.<sup>54</sup> "In its [value engineering's] language, the part is not the design, the design is not the function. Every translation [of design] is treason", SAVE Consultant Georges Gouze explained to highway officials considered "value specialists in training" upon attending VE training workshops held at the offices of the American Society of Civil Engineers.<sup>55</sup> The highway bridge designs selected serve as analytical matrices of engineers' conceptual design decisions in this operational technique of adaptive planning—as if they were a system, procedure or method of synetics, which manage a bridge between a two classes of methods, or one of the five elements of structuralism employed in value engineering not coincidentally, namely classification, rearrangement, structure, and semantics,<sup>56</sup>

The psychological perspective of Altschul and other "expert lectures"<sup>57</sup> on the operations of value analysis invited to this and later federal conferences adds imagination to the fact finding undergirding the operations research conventional to decision analysis in highway building research. The authors of such "Imagineering"<sup>58</sup> prefer to call this merger of projective visions of systems building from retrospective studies of design decisions "speculative thinking" about the creativity of engineers rather than a refashioning of such creative thinking as "freedom" from the complexity of American civil engineering culture and its "tangled web" of building activities.<sup>59</sup> "A definite and conscious creative function aimed to discover new facts, arrive at new

---

<sup>54</sup> The Transportation and Community Values Conference was organized jointly by the Transportation Research Board's Commission on Sociotechnical Systems, the Highway Research Board, and the National Science Council.

<sup>55</sup> Gouze, p. 2.

<sup>56</sup> Ibid, p. 4.

<sup>57</sup> Roger Creighton, Introduction, *Transportation and Community Values*, p. 18.

<sup>58</sup> Maks A. Stajich, *Value Engineering Through Creative Thinking, SAVE Conference—1971* (Smyrna, GA: Society of American Value Engineers, Inc., 1971), p. 12.

<sup>59</sup> Creighton, p. 13.

combinations, and find new applications,”<sup>60</sup> value analysis’ trope of ‘adaptive planning’ for ‘alternate futures’ offers this social notion of transportation planning at the time in an analytical and operational sense of economic planning. A concept with as many faces as the creative thinking it defines in political and cultural theory of value engineering,<sup>61</sup> the freedom of nondeterministic mechanisms of selection would specifically take command away from the deterministic mechanisms of master planning that Sigfried Gideon chronicles in 1958,<sup>62</sup> and create a “freedom of choice”<sup>63</sup> between alternatives creatively developed by planners, engineers and contractors.

To incorporate value engineering’s contemporary visual and technological “features of freedom”<sup>64</sup> from established ways into the industrial mechanisms and urban forms of the American highway system faced as many obstacles in the late 1960s as more affirmative acts of integrating multi-valued thinking into American culture. To loosen the structure of a highway system built expeditiously pre-WWII as a National Defense Highway System, ‘form follows function’ proved too limiting as a method of executing post-WWII plans for regional distribution networks to decentralize dense populations away from so-called “potential bombing targets” and the “dangerous

---

<sup>60</sup> Ibid.

<sup>61</sup> A seminar course in science and technology studies titled “Technology and Freedom” (Fall 2005) and taught jointly by Leo Marx and Rebecca Herzig at MIT found freedom to be a subject of cultural discourse on technology since the 19<sup>th</sup> century. However, in the latter half of the twentieth century, this object of social criticism became a subject of cultural studies as well because of the cultural criticism of transportation building. Like the lines between social and cultural theory in technologies studies, the line between knowledge about freedom and views of freedom are blurred.

<sup>62</sup> See, Sigfried Gideon, *Mechanization Takes Command: A Contribution to Anonymous History* (New York: Oxford University Press, 1948). David Billington and Robert Mack’s first course on “Civil Structures in the Urban Environment” (Princeton, NJ: Princeton University Department of Civil Engineering, 1967) communicates the same sentiments in 1967, citing the same urban civil engineering forms—the cloverleaf interchange, the multi-grade ‘LA interchange’ and the typical urban expressway built through old urban fabric.

<sup>63</sup> Altschul, p. 51.

<sup>64</sup> Miles, p. 111.

elements” of the city.<sup>65</sup> Design of streamlined highway bridges across the urban industrial districts that used to house the postwar fabrication plants as well as highway bypasses built outside environmentally sensitive and socially contentious areas trivialized the civil government’s vulnerable position in maintaining both these new defense structures’ single-threaded form and their essential function of circumvention. Both “use function,” which performs a use, and “aesthetic function,” which pleases, were important, the chairman of Senate Committee on Public Works and the Environment noted in 1969 as he signed provisions for value engineering into the 1970 Federal Highway Act’s renewal.<sup>66</sup>

Creating equivalency between function and form of a new defense against conformism to the tried-and-true, would surely come with a price tag totaling capital and human resources (i.e. time and additional expertise) over which federal highway administrators were willing to allocate to bridge and highway type selections with little use beyond their primary mechanical function. Holding off on the procurement of materials and contractors until the structural support for that form materialized from structural engineers’ analysis had yielded costs well over the budget allocated in 1947 for highway spurs and extensions that would unite the U.S. highways into a single system with one level of horizontal integration.<sup>67</sup> “Standard details that are used repetitiously on many projects” civil engineers could continue to exchange with the new materials and methods for existing bridge types to ensure “program-wide application of value engineering developed by 1980.”<sup>68</sup> However, this process would move too slowly towards the benchmark that Senate officials considered “reasonable” for changes in the

---

<sup>65</sup> Galison, “Peter Galison, “The War on Space,” *Architecture and the Sciences Exchanging Metaphors*, eds. Antoine Picon and Alessandra Ponces. (New York: Princeton Architectural Press, 2003), p.215.

<sup>66</sup> Provisions for Value Engineering, Federal Highway-Aid Manual 6-1-1 (Washington, D.C.: FHWA, 1970).

<sup>67</sup> Richard Weingroff, “The Greatest Decade Part 1: Essential to the National Interest, 1956-1966,” <http://www.fhwa.dot.gov/infrastructure/50interstate.cfm>, December, 2006.

<sup>68</sup> Proceedings on Value Engineering of the U.S. Senate Committee on Public Works and the Environment (Washington, D.C.: U.S. Government Printing Office, 1967).

“wasteful pattern of American construction practices.”<sup>69</sup> Summed up in the 1971 SAVE Conference session on the Philosophy of Value Engineering, creative thinking about industry is the epistemology of the so-called “VE state of mind,”<sup>70</sup> for the social trajectory of highway project selections diverge from the cultural traditions of technological decision-making in bridge engineering.

The prospect of bridge design components and construction concepts that were selected in the preliminary stage of projects losing economic viability for industry investment and government financing years later was real in the case of interstate highway bridges mired in controversy or stalled in review processes. For example, to avoid their plans’ not acquiring funding after the November 1968 assemblymen elections in Hudson County, the NY Bridge Authority solicited bridge proposals for a twin span of the Newburgh Bridge (1963) from politicians running for election. Broken down in regards to the federal construction loan interest rates and the Equivalent Uniform Annual Costs that developed over the course of this political and highly public review process, comparable costs between the alternative bridge designs rise precipitously in cost once the impact of inflation as well as maintenance costs are extended beyond the time and space frame of construction per se (fig. 1.1), as in the economic analyses of structural engineer Au Tung.<sup>71</sup> Modjeski and Masters engineers’ initial construction cost estimates of \$130,000 for the steel bridge’s design proves to account for less than half of the costs that actually materialized by the commission of Modjeski and Masters’ for design as such possessed to feasibility studies of the second span construction in 1972.

---

<sup>69</sup> Ibid.

<sup>70</sup> Georges Maurice Gouze, “Value Engineering and Creativity: A Double Self Generating Tool of Management,” Proceedings of the SAVE Conference-1971, p. 2. Previously cited paper by Carlos Fallon and an introduction by Lawrence Miles precede this paper in this session.

<sup>71</sup> Au Tang, “Decision-Making under Uncertain Conditions” presented at the ASCE National Structural Engineering Meeting, Baltimore, April 19-23, 1971.

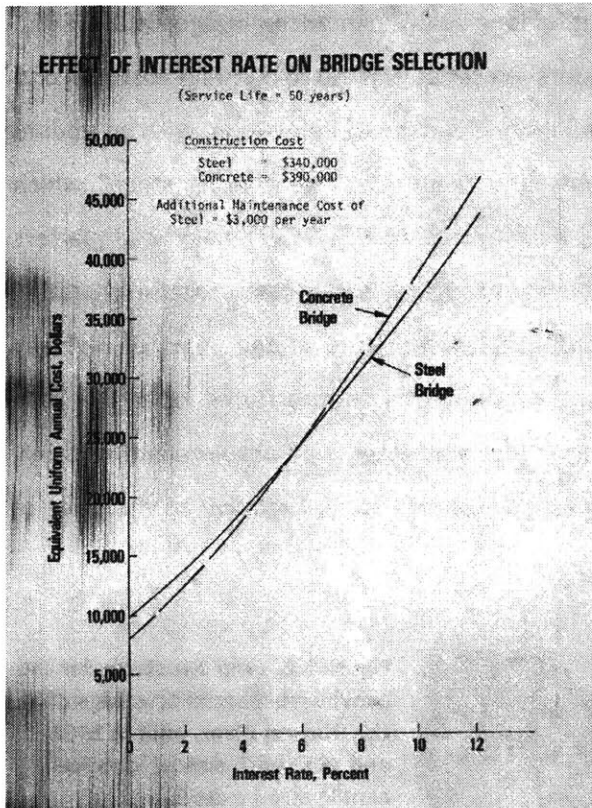

Figure 1.1. "Effect of the Interest Rate on Bridge Selection," (Au Tang, "Decision-Making under Uncertain Conditions," 1971 ASCE National Structural Engineering Meeting)

Equivalent Uniform Annual Costs (\$) versus the Interest Rate (%) over a service life of 50 years for a Concrete Bridge and Steel Bridge with respective 'Initial Construction Costs' of \$390,000 and \$340,000 and additional maintenance costs of \$0 and \$3,000/year

Even with their disregard for the precise form of the historic Newburgh Bridge's steel cantilevered space frame, procuring within budget the industrial components and production assurances necessary for Hudson County to break even required Modjeski and Masters engineers to speculate upon the benefits of alternative forms of steel technologies. The precast concrete deck and girder bridge construction with which Tung compares the steel cantilevered bridge design of Modjeski and Masters was ruled out at the start of the project by the Democratic, Republic and Independent assemblymen running for election. All three proposed "big steel designs," according to Assemblyman Richard Schermerhorn, because the public "would not have gone for [a mixture of concrete and steel bridges] at the site of an "industrial-looking bridge" that had won

awards for being one of the “most beautiful long-span”<sup>72</sup> American bridges in 1963 (fig. 1.2).<sup>73</sup> The benefits of Modjeski and Masters’ presence of mind to consider costs beyond the ‘now-time’ frame is instead exploited beyond structural innovation, with an update of the steel truss structure’s steel grade and texture to “weathering steel,” which debuted two years earlier in designs for construction of U.S. Steel’s new headquarters building (Pittsburgh, PA, 1966).<sup>74</sup> The challenges Modjeski and Masters face in mitigating the new and old values of bridge functionality is the issue at the heart of highway officials’ criticism of structural engineers’ continuing to choose forms, or in this case allow the choice, of bridge types and forms that may already be obsolete and certainly less essential to the interstate transportation system’s vitality relative to the pace of technological development.<sup>75</sup>



**Figure 1.2. Twin structures for the Newburgh-Beacon Crossings of the Hudson River, built in 1962 and 1971 with almost identical cantilevered truss form (NYSBA, [www.nysba.state.ny.us](http://www.nysba.state.ny.us))**

---

<sup>72</sup> Award for Long-Span Bridge Beauty bestowed upon this original bridge (on the left) in 1965 by the American Institute of Steel Construction, according to the NY Bridge Authority.

<sup>73</sup> Assemblyman Richard Schemerhorn, Newburgh-Beacon Bridge Newburgh Bridge (1968), NY Bridge Authority highway bridge archives, [www.nysba.state.ny.us/bridgepages/NBB/NBBpage/history/nbb\\_history4.htm](http://www.nysba.state.ny.us/bridgepages/NBB/NBBpage/history/nbb_history4.htm), April 25, 2007.

<sup>74</sup> “Big Steel Spike: the U.S. Steel Building is a Symbol of both an Industry and a city,” *Architectural Forum*, vol. 135, no. 5, (Dec 1971), pp. 25 (24-29).

<sup>75</sup> Newburgh Bridge (1968), NY Bridge Authority highway bridge archives, [http://www.nysba.state.ny.us/bridgepages/NBB/NBBpage/history/nbb\\_history4.htm](http://www.nysba.state.ny.us/bridgepages/NBB/NBBpage/history/nbb_history4.htm), April 25, 2007.



The “value benefits of value analysis”<sup>76</sup> for both the technological development of civil engineering culture and bridge project selections are proven further through the analytical studies of alternate structural systems presented to highway bridge administrators of the federal-aid program that met in. Even miles away from the euphoric setting and fertile grounds of “an island of liberal thought” for which the Airlie House was built in 1960,<sup>77</sup> highway project administrators considered whether the number of alternative designs that systems engineers considered and the number of iterations that their designs underwent connote they could “add meaning to technological development”<sup>78</sup> in civil engineering. With UC-Berkeley architects and engineers<sup>79</sup> juxtaposing steel and concrete designs for each function prescribed for the School Construction Systems Design (SCSD) rather than the steel and concrete designs for each component of the school building type, value engineering’s principle questions, “what is the function?” and “what is the cost?” could simultaneously be answered in the economic evaluation of such “alternate designs.”<sup>80</sup>

Mirroring the if-then clauses of a computational framework, alternate steel and concrete designs for the structural and mechanical floor systems of these school buildings (fig. 1.3 and fig. 1.4) are evaluated in terms of economic *values* versus descriptive absolute costs. The various scenarios for these systems’ assembly and erection in the computational sphere are optimized to reflect the conditions of the school construction market when preliminary design studies of their economic value

---

<sup>76</sup> Macedo, et. al, p. 18.

<sup>77</sup> Now called the Airlie Center, the Airlie House is also an independent institution from the federal government. See, [www.airlie.com](http://www.airlie.com)

<sup>78</sup> Building Research Advisory Board, Federal Construction Council, Value Engineering in the Federal Construction Agencies, Symposium-Workshop Report Number 4, May 27, 1969 (National Academy of Sciences, 1969).

<sup>79</sup> Dell’Isola, *VE in the Construction Industry*, p. 177.

<sup>80</sup> John R. Bolce, *A History and Evaluation of SCSD* (Building Systems Information Clearing House, Educational Facilities Lab, Ford Foundation). School Construction Systems Designs were applied to the structural and non-structural systems of Walt Disney World, Orlando (Heery & Heery Architects, Engineers and Construction Managers) and to the Southern California school system, p. 85.

conduct comparative analysis on the relative scale of costs' worth—their “present value” in the economic marketplace—rather than the “true value” of cost units for each of the designs' commercial and industrial components. Selecting one design over the other for the school construction system according to marketplace relations of completion for each, such as the design's emerging versus established or moving versus stagnant position relative to an alternate, allows no characteristic specific to steel or concrete materiality (i.e. their structural capacities and mechanical properties) to define the two designs' alternate relationship to one another.

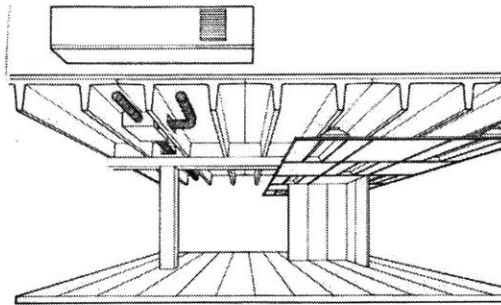

**Figure 1.3. Steel alternate for floor system**  
*(Report on SCSD, 1968)*

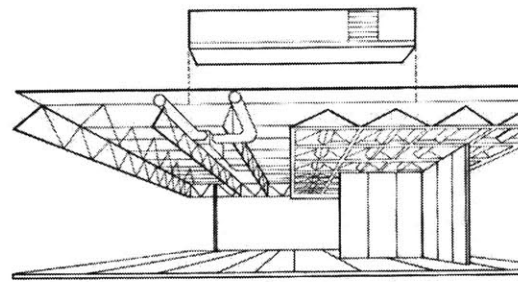

**Figure 1.4 1. Concrete alternate for floor system**  
*(Report on SCSD, 1968)*

Even for construction systems where there would be more numerous and more complex building systems, such as the office towers also analyzed in this study,<sup>81</sup> the dialectics of comparative study remain a matter of market scenarios for designs rather than traditional schemes of industry competition for the high-rise type of building construction. A concrete panel construction scheme for a modular workspace (fig. 1.5) involves a different set of fabrication methods and labor trades than the steel alternate (fig. 1.6) to be erected from comparatively similar components in a completely different sequence of connecting parts, Nonetheless, by systems building's economic market

---

<sup>81</sup> Ibid.

theory of competing options pluralist conceptual design,<sup>82</sup> the difference between these factors' unit costs are scaled based upon their value to the market investors to equivalent and uniform annual costs of industry developments in the high-rise marketplace. Admittedly more representative of mass-consumerism than the macroeconomics of postwar engineers' "cost analysis,"<sup>83</sup> value analysis and the engineering of designs based upon economic outcomes for alternate design scenarios more than alternate between the "zeros and ones" framework of computing systems' two optimal options for selection.<sup>84</sup> That the two building panel construction schemes appeal to the concrete industry, on the one hand, and to the steel industry on the other represents neither the parameters for economic evaluation nor a coincidence. UC-Berkeley's research of "systematic search techniques"<sup>85</sup> was financed by the National Science Foundation with the intent that a contract with industry partners not presently serving on the Federal Construction Council would yield savings for municipalities less invested in national and international marketplaces.

---

<sup>82</sup> For a basic summary of this relationship between systems engineering (design, analysis and construction) and the theory and practice of value engineering, see, John D. Grothuis (Certified Value Specialist, CVS), "Cost-Function Relationships," *SAVE Conference--1977*, Vol, 11, pp. 224-26. For more depth into the economic theory of systems building at this time, see *Probability, Statistics and Decision for Civil Engineers*, eds. Benjamin, J.R. and Cornell, C.A. (New York: McGraw-Hill, 1970).

<sup>83</sup> The theoretical differences between cost and economic analysis in civil engineering decision-making is defined as the theoretical distinction between estimation of absolute economic values and speculation of subjective economic values—construction versus investment economics in Robley Winfrey's *Economic Analysis for Highways* (Scranton, PA: International Textbook Co., 1969). The start of this cultural discourse in civil engineering culture could be said to begin, however, with transportation decision analysis dating back to 1957-8 with work such as Clarkson Oglesby and Eugene L. Grant's "Economic Analysis—the Fundamental Approach to Decision in Highway Planning and Design," *TRB, Proc. 37: 45-57* (1958). This assumption agrees with Michael Latham's confluence of 'nation-building' transportation projects in the 'Third World' and American civil engineering culture's expansion into this area in the 1960s. Michael E. Latham, *Modernization as Ideology: American Social Science and "Nation Building"* (Chapel Hill: Univ. of N. Carolina Press, 2000), p. 24.

<sup>84</sup> Au Tang, "Decision Processes and Computer Methodology," ASCE National Structural Engineering Meeting, Baltimore, MD, April, 19-13, 1971, pp. 1-11.

<sup>85</sup> Baron, F. and Lien, S.Y. "Analytical Studies of the Sothern Crossing Cable-Stayed Girder Bridge," Report No. UC SESM 71-10, Vols. I and II, Dept. of Civil Engineering, UC-Berkeley, California (1971). The cities of San Francisco and Oakland were considered such "municipalities," p. 3.

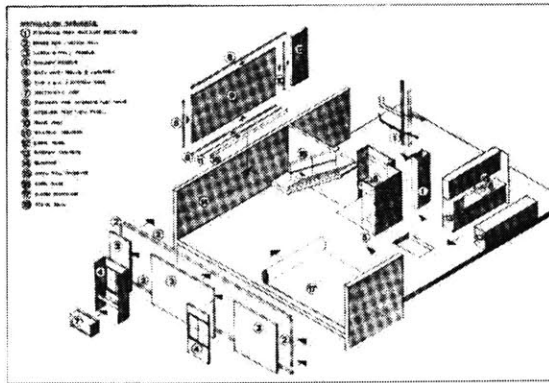

Figure 1.5. Construction sequence for the “concrete alternate design” of building system using panels (*Report on SCSD, 1968*)

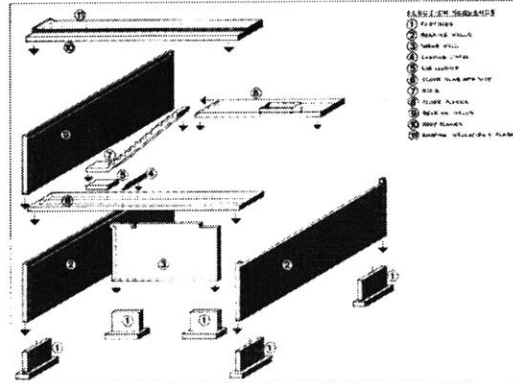

Figure 1.6. Construction sequence for the “steel alternate design” of building system using panels (*Report on SCSD, 1968*)

For the Federal Construction Council that met in 1969 for its Symposium on Value Engineering, mere creation of such alternate designs and a search for potential savings to be found between them in the economic arena made provisions—financial and social—for industry competition between structural types and structural systems. Seeking “measurable outcomes” to yield the economic worth and original cost for all of the designs evaluated in these iterative design studies, not just the two optimal selections, the council throws aside systems engineers’ rating values of ‘1’ or ‘2’ as well as value analysts’ notation of ‘B’ or ‘S,’ as in basic or secondary to designate alternate designs’ priority to the value of original costs on the one hand and opportunity costs of increased functionality in future construction systems on the other (fig. 1.7).<sup>86</sup> Retained in their call for economic analysis of emergent technologies’ impact on the viability of established ‘structural types’ in the future,<sup>87</sup> however, are the general semantics of both systems building and value analysis undergirding the public discourse on value engineering thus far. In favor of analyzing the functional and aesthetic value of

<sup>86</sup> Dell’Isola, *VE in the Construction Industry*, Appendix III.

<sup>87</sup> Building Research Advisory Board, Federal Construction Council, *Value Engineering in Federal Construction Agencies*, Symposium-Workshop Report No. 4, May 27, 1969 as recalled by Council member A. Dell’Isola in *Value Engineering in the Construction Industry* (John Wiley & Sons, 1974), p. 177.

structural types on a multi-valued scale of 0.0 to 1.0 throughout their analysis of VE,<sup>88</sup> the construction council members leave value engineers' market competition ethos to be worked out in each federal construction agency's specific field of VE application.

### FUNCTIONAL ANALYSIS WORKSHEET

PROJECT Deck for refueling pier ITEM Pier deck design  
Load design 100lb/sq ft, 1<sup>k</sup>concentration load - 20ft span Transmit load

QTY.	UNIT	COMPONENT	FUNCTION			EXPLANATION	WORTH	ORIGINAL COST	
			VERB	NOUN	KIND				
3555	sq ft	Timber section	Transmit	Load	B	Tensile load	\$ 2,500*	\$ 8,750	
			Support	Concrete	S		-----		
		Shear plates	Transmit	Shear	S		-----	1,000	
			Nails	Hold	Parts	S		-----	1,400
							Total tensile	2,500	\$11,150
							Cost/value = 4.5		
3555	sq ft	Concrete section	Transmit	Load	B	Compressive load	\$ 2,500*	\$ 3,600	
			Provide	Drainage	S				
			Provide	Safety	S	Curbing and fire			
		Rebar	Distribute	Stress	S	Prevent cracking		2,560	
						Total compressive	2,500	6,160	
							Cost/value = 2.5		
		Bolts	Hold	Parts	S			180	
		Copper pipe	Remove	Water	S			60	
					TOTAL =	\$ 5,000	\$17,550		

\*Based on a simple span (20-ft) wooden deck.

Figure 1.7. Value engineers' Functional Analysis Worksheet for decision analysis. Project: Deck for a refueling pier to be constructed like a simple 20-ft span wooden deck. (Dell'Isola, *VE in the Construction Industry*, 1974)

Economic evaluations of specifically preliminary designs' feasibility in present and future market conditions would define the limited relativity of worth across the life-cycle of highway bridges. A cross between the General Services (Public Building

<sup>88</sup> As recalled by Council member Alphonse Dell'Isola in *VE in the Construction Industry*, p. 177.

Service) Administration's allowance for more creativity on the part of architects and structural engineers in creating an "atmosphere of competition" between designs<sup>89</sup> and the Federal Highway Administration's concern with decisions based upon that atmosphere,<sup>90</sup> the linguistic framework for functional analysis of original costs and worth at a specified date of evaluating project selections derives from the 'functional analysis *systems technique*' (FAST) first introduced at the 1964 SAVE Conference by a frequent contractor to the Federal Highway and General Services Administrations, Charles Bytheway. With Lawrence Mile's descriptive and product-focused noun-verb approach leaving much to be desired in regards to the evaluation of time distinguishing the numerous established bridge types and alternate designs drawn from contemporary innovations and inventions of new structural types forming emerging markets for new construction trends. Established as a relativist yet rational decision-making process for selecting government facility contracts with potential for future value growth, the engineering of 'value systems' from analytical structures of linguistics and semantics not the engineering management of physical constructions and structural systems was the intended application of this technique, however. the FAST diagramming of Mile's "noun-verb approach" to design elements and their function in construction systems was only supposed to create a schematic for selection akin to the 'sentence outline'<sup>91</sup> for its essential parts not solve the designs or construction management issues pertaining to the functional and aesthetic value of commercial products in built form. Like its model, which is designed to ensure the elements of a sentence *will* make sense as a whole and do so semantically in a specific structure, a FAST diagram composed by preliminary

---

<sup>89</sup> Value Engineering Handbook, Notes from the Conference on Value Engineering, held by the General Services Administration, Jan 1972. Harvard Business School, Cambridge, MA.

<sup>90</sup> *VE for Highways* (Handbook), 1<sup>st</sup> ed., (Washington, D.C.: FHWA, 1970).

<sup>91</sup> Charles W. Bytheway, CVS, "Function Definition and FAST Diagram Construction," Workshop IV: Function and FAST, *SAVE Conference—1977*, Proceedings of the 1977 International Conference held in Dearborn, MI, May 23-25, 1977 (Smyrna, GA: American Society of Value Engineers, 1977), pp. 220-222. It is noteworthy for this study of bridge constructions that Bytheway was a project manager for Turner Construction Company when he began applying this method of functional analysis with which his name is synonymous in value engineering discourse.

economic analyses includes no—frameworks not content. Nonetheless, these elements perform their essential function: to communicate meaning for the whole to come.

Consulting engineers to the federal construction agencies that employ this FAST comparative framework to economically analyze preliminary designs' feasibility for highway systems building not only must speculate upon the total costs of design elements but also encourage the development of competitive construction scenarios applicable across the entire building culture not just that of highway bridge building.<sup>92</sup> Construction projects' total costs, including the opportunity costs of selecting one alternative over another, materialize only over the course of a project—a bridge's service life. Industrial engineers of SAVE did not limit this concept of life-cycle costs to analysis of bridges. If building technology (not yet a term reserved for the technology of buildings) possesses a market value reliant on functional as well as aesthetic value of a commercial marketplace, then functional design and 'appearance design' of similarly conceived 'structural types' for all types of built form translate into value for all applicable project selections reads the logic of these multidisciplinary studies of competitive "type selection."<sup>93</sup> Bringing the economic trends for post-industrial development of building (verb) technology (noun) into the analytical studies of structural types for bridges, such FAST diagramming of the entire structural component market as a single economic system disregards the civil engineering and architectural fields' distinct disciplinary values and traditions for such components as the long-span steel flange beam and precast concrete segmental beams. Life-cycle analysis that draws into feasibility studies for bridge type selections the values of building type selections merges the two disciplines' alternate futures with commercial enterprise instead.

With the multiple applications of this latter interpretation of the 'functional analysis systems technique' (FAST), Turner Construction Company authors of the

---

<sup>92</sup> Note the literary references value engineers employed to describe their methods of deconstruction and construction, and their similarity to social constructivism.

<sup>93</sup> Roger A. Lockwood, "Interdisciplinaryism: Rx for V.E.," SAVE Conference—1968 (Chicago: Robert J. Mayer & Co., 1968), pp. 141 (137-143).

method gained the prized designation to contribute introductory text on construction systems for the second edition of *Techniques of Value Analysis and Engineering* (1972), an honor previously accorded to architect Alphonse Dell'Isola while he served as chairman of the SAVE Committee on VE in Construction. Decision-trees and flow-charts for "value engineering thought"<sup>94</sup> about construction systems replaced Dell'Isola's "overdetermined belief in autonomous, internally motivated 'choice' from among standardized products and behaviors," and even softened the 'value control' of Dell'Isola's *VE in the Construction Industry* (1974) into rational choice from "plural cost-value ratios."<sup>95</sup> Rational choice of engineered industrial systems optimizes the relativity of various construction scenarios arising from different fields' if-then clauses simulating the game-theoretic of constantly fluctuating changes in decision-making conditions.<sup>96</sup> As capital investments in the fluctuating building (verb) technology (noun) marketplaces of changing steel and concrete alternate designs closed out the Federal Construction Council's 1969 Symposium on VE, a return to the conference introduction was made. Fittingly, the conference opened with Dell'Isola announcing the Council's supportive position on VE and seating Lawrence Miles in the moderator's chair for discussion amongst a community of civil engineers by no means skeptical of the savings and benefits in construction financing that SAVE consultants, military personnel, FHWA and GSA officials were to develop further as a new decade dawned.

---

<sup>94</sup> Comparison of the appendices of these chapters all shows shift between Lawrence Miles's *Techniques of Value Analysis and Engineering*, 1<sup>st</sup> ed. (New York: McGraw-Hill, 1961) and *Techniques of Value Analysis and Engineering*, 2<sup>nd</sup> ed. (New York: McGraw-Hill, 1972).

<sup>95</sup> Dell'Isola, p. 53.

<sup>96</sup> With competition as the only sure condition of marketplace conditions, "consensus is what matters most" in the scenarios of rational choice." The most popular scenario of 'rational choice' highlights how the "features" of designs can lower the market value of one design relative to another due to its relevance to the consumers who seek that functionality from appliances despite higher original costs relative to other appliances in the commercial market for laundry machines over dishwashers (almost always "she" and "her" in these studies that refer back to the surveys of postwar consumerism in professional women). "Rational Choice: Life Cycle and Value Analysis of a childless marriage," *SAVE Proceedings--1966*. (Chicago: Robert Mayer & Co., 1966), p. 130. One humorous cartoon proposed that "if I were to kiss you then there is a 17% probability that we might get married and that has a 24% likelihood that we'd have children with a 34% chance of divorce...I'm not sure I can risk it!"



When structural engineers, who were invited to the Federal Construction Council's Symposium, probed as to why civil engineers more knowledgeable in the composition of *sociotechnical* systems were not involved in defining incentives and strategies for incorporating value engineering into bridge projects, Council member A. Dell'Isola responded that "function and cost of construction are the values upon which we all aim to base our decisions; neither requires the specific definition of any particular discipline besides value engineering."<sup>97</sup> Dell'Isola's years as the Director of VA/VE for the Navy Yards and Army Base construction agencies had earned him the criticism of architects and structural engineers as well as the favor of federal officials,<sup>98</sup> an uneven trade-off arguably made by civil engineers in their daily practice. Construction-related but non-construction decisions regarding bridge types had figured into the ratio between bridge components' material and labor costs but the economic value of these components in the construction industry the bridge engineers employed in state highway offices and those consulting on the offices' projects had yet to merge with their existing practice of bridge type studies. The lack of civil engineer involvement in the "VE effort" would not last long, however, as bridge engineers saw themselves being marginalized by the now recognized Professional Engineers of value engineering and saw opportunities for their individual firms to get in on the ground level of a sea change in American civil engineering culture evident in its changing professional landscape. Partners of Howard Needles Tammen and Bergendoff (HNTB) since WWII recalled in 1989 when the firm incorporated its sports architecture services in HNTB Architecture that "a lot of us older engineering firms got scared when states started adopting those

---

<sup>97</sup> Transcript from the Federal Construction Council Symposium on VE, 1969 in *Value Management for Construction*, p. 7. Alphonse Dell'Isola, who was a reference for value analysis and engineering founder himself, Lawrence Miles, for the construction industry text in *Techniques of Value Analysis and Engineering* (1961), Dell'Isola had become the authority on the construction of functionally efficient government facilities well before his own seminal text, *VE in Construction*, was published in 1974.

<sup>98</sup> Paige Clint, "Question: What is Value Engineering of..." (hanging phrase is in fact the title), *AIA Journal*, Vol. 62, No. 1 (July 1974), p. 41 (41-43).

value engineering programs and jumped ship to the private sector where experience was valued over market conditions.”<sup>99</sup>

The Federal Construction Council, a bit more aware of its political alliances with this mainstream civil engineering community, instead merely sought for civil engineers to collaborate with industry and SAVE’s industrial engineers on the process of selecting bridge structures and highway components with value potential versus the probability of value loss. With the support of the steel and concrete industries, consequently, value engineering requirements gained the political support to be added to the Federal-aid Highway Act of 1974, by which states and municipalities were to receive federal aid for the replacement of “pertinent and major structures”—bridges greater than 150 feet in main span or 200 feet total length in urban areas or to link interstate roadways with metropolitan areas. In return, Congress added provisions for industry suppliers as well as contractors to share the savings and benefits generated by engineers and contractors’ alternate designs. “The reason we should avoid words like ‘thinking’ the most economical bridge selection has been made is because we cannot reduce it to *measurables* and demonstrate it; behavior is measurable,”<sup>100</sup> policy-makers explained. So too, such thinking suggests, are the cost savings produced in divergent, alternative designs for the same alternate future.

Engineering bids proposed in terms of cost benchmarks for investment in highway bridge projects abroad hinted to this ‘alternate future’ of multi-system designs producing savings for both contractors and the government. They also foreshadowed a future of mandatory selection of construction schemes and design scenarios versus actual designs, even of an innovative nature, for execution. As they had done before all of the leading bridge and structural engineers in attendance at the 1966 Symposium on Suspension Bridges in Lisbon, Portugal, German engineers of Leonhardt and Andra

---

<sup>99</sup> Kathie Ann Brown, *Diversity by Design: Howard Needles Tammen Bergendorff* (New York: HNTB, 1989), 116-17.

<sup>100</sup> Decker, p. 14.

Partners would take offense to this multi-valued framework of market competition not fitting the model of ‘free market competition’ that American economists and engineers had established in West Germany post-WWII. Their criticisms, which claim Tagus River Bridge administrator Cardoso absorbed an “unnecessary \$34 million” to appease American “good neighbor” policies, were corroborated by Cardoso, but the barn door had already been opened, when the results were presented to the international leaders of bridge engineering brought together for this first international conference on suspension bridges in 1966.<sup>101</sup>

Cable-stay systems combined with the stiffening truss construction of distinctively mass-heavy “American suspension bridges”<sup>102</sup> in the feasibility report of U.S. Steel Corporation’s illustrious American Bridge Division enabled the latter design to endure in a market where such proposals for long-span construction deficient in material efficiency were the focus of an infamous debate on American engineers “wasteful designs.”<sup>103</sup> Adding an additional structural system to the truss structure and substituting a nuanced erection scheme for suspension bridge construction (fig. 1.8), American bridge engineer Robert Steinman’s design for the Tagus Bridge (Portugal, 1968) allows the U.S. Steel Corporation to propose that expandable steel plate decks and modular lane use provisions (a la mixed-use land and building provisions) be added post-construction of the basic structural system when functional needs of the regional transportation system and economical needs of Portugal’s toll bridge authority deem expansion necessary. As it appears now, the incongruence between standards of absolutism for these structural solutions to wind loads and problem-solving methods of speculation for achieving them was glaringly obvious then,<sup>104</sup> years prior to the social

---

<sup>101</sup> Richard Scott, *In the Wake of Takoma*, pp. 170-175.

<sup>102</sup> *Ibid*, p. 170.

<sup>103</sup> See pp. 170-175 for Scott’s survey and analysis of the numerous letters submitted to ENR and Civil Engineering-ASCE by Robert Steinman, Othmar Amman and the younger engineers of their firms on the one hand, and by Fritz Leonhardt, and engineers of Freeman Fox and Partners on the other hand.

<sup>104</sup> *Ibid*, p. 171.

science of this shift blossoming into the value engineering culture of American civil engineering and transportation management.

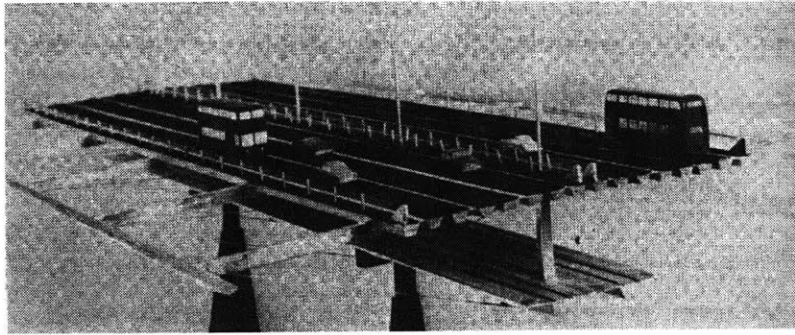

**Figure 1.8. Tagus River Bridge Proposal for additional lanes, U.S. Steel Corp., American Bridge Division; (Scott, *In the Wake of Tacoma*, Reston, VA: ASCE Press, 2001)**

Under this new rubric of non-deterministic decision-making through “VE in design...when cost versus value imbalance is indicated,”<sup>105</sup> consultants on bridge projects heed financial management guidelines for engineering the “divergent, many-answer approach” to bridge selection. Contractual connections to the original designer, Steinman in the case of the Tagus Bridge, needed not be a concern of administrators, this ironic take on the act of ‘bridge selection’ suggests. With Steinman compensated for his preliminary design and erection and assembly schemes but not for design of the bridge’s ultimate construction, there was no ethical quandary for the American Societies of Professional and Civil Engineers to investigate as some believed they should. In fact, this approach was to yield for both consultants and client “more choices, the essence of [value engineers’ notion of] freedom” from confining visions of the future drawn in the past.<sup>106</sup> Design decisions that take place in the alternate future, such as Tagus Bridge administrator Cardoso deciding that Portuguese labors would construct the additional bridge decks to be stayed by cables using precast concrete segments not weathering steel trusses initially proposed, could work against even the value engineer’s best ally,

---

<sup>105</sup> Hal Tufty, Value Engineering Now Included by EPA in Construction Grant Programs, *Professional Engineer*, v 45, n 6, Jun, 1975, p 36 (36-38).

<sup>106</sup> Stajick, p. 13.

U.S. Steel contractors in this case. However, such open-ended and reversible decision-making worked in U.S. Steel's favor in the short-run, for the corporation won the contract, their competitors' recognition and \$34 million worth of government support—value growth by the standards of commercial corporations.

Justifying this admittedly “discriminative and manipulative behavior”<sup>107</sup> of design-phase value engineering was the indeterminate or at least yet unknown functionality of a new type of system—cable-stay systems, namely—for which schemes for its erection with other structural systems abounded with possibility. As a type of systems construction that projects a type of construction system, the multiple and divergent designs of this structural type for the Tagus Bridge minimize the role notions of feasibility historically derived from the suspension bridge type studies play in present economic evaluations. The federal construction agencies jumped, not surprisingly, at relating politicians' value control guidelines for alternate designs of building construction systems with their structural engineers' take on functional construction systems designed, analyzed and built to redistribute the fuzzy and chaotic, staged and tabular forms of economic decision-making in the multi-value yet structured organization of U.S. highway building. This merger of disciplines defines bridge selection as the review of new systems construction techniques (which seem to hail more so from the American Institute of Industrial Engineers' Engineering Economics Division and schools' Divisions of Systems Engineering than the ASCE)<sup>108</sup> even though review of designs by the public and federal officials as well as historical reflections on design and construction problems federal officials had cited at the start of VE policy-making as the source of value loss and the reason for why federal construction agencies could not go with value engineering in the 1970s.

---

<sup>107</sup> Tufty, p. 37.

<sup>108</sup> Such as Michael M. Sprinkel (Virginia Highway and Transportation Research Council), et. al, “Systems Construction Techniques for Short Span Concrete Bridges”; Also see, Roy Tokerud, P.E. (FHWA) “Economical Structures for Low-Volume Roads” and Craig A. Ballinger and Walter Podolny, Jr. (Dept. of Transp.), “Segmental Bridge Construction in Western Europe—Impressions of an IRF Study Team” in 1978 Symposium of the Commission on Sociotechnical Systems.

On the vital difference between humanistic survey and social scientific analysis, the FHWA was more than eager to inform state and federal project administrators. The new method of Lawrence Miles' 'problem-setting' and 'problem-solving'<sup>109</sup> is distinct from civil engineering but applicable to civil construction systems, elevating the role of structural engineering to the vertical integration of them both in the social structure of highway bridge building. In fact, in 1969 George Begg, then the Director of Urban Development and the coordinator of engineers' role in building 'urban form', "hereby declared value engineering as an engineering and architectural discipline that (1) focuses attention on the essential function in a chosen design or construction objective, and (2) emphasizes meeting that essential function at the lowest total cost projected for the objective's completion."<sup>110</sup> Perhaps, FHWA officials hoped that splitting hairs outside their Bridge Office would avoid resistance to the underlying plan of their initiatives to foster collaboration between engineers and contractors, contractors and industry on bridge projects that would soon be announced as a policy to make contractors not contracts for bridge designs the social and technical link between the former and latter.<sup>111</sup>

Collaboration with industry partners as well as structural engineers on bridge projects developed immediately with FHWA officials concerned about high-capital and high-profile bridge selections to cross the I-410 highway bypass over the Mississippi River, twice, each at the New Orleans suburbs of Luling and Chalmette. When Lewis Mumford and environmentalists' editorials in the *Times-Picannye*, the rioting and protests, letters to the Department of Transportation and city council revolts are in the foreground, the Louisiana Division of Highway's so-called "economical bridge plans" in 1968 appear more a part of the "uglification of America" with which *Newsweek* editors

---

<sup>109</sup> Miles, *Techniques of Value Analysis and Engineering*, 2<sup>nd</sup> ed., (New York: McGraw-Hill, 1972), pp. 45-70.

<sup>110</sup> George Begg as quoted in full by Miles, *Ibid*, p. 313.

<sup>111</sup> Already FHWA officials were working on a policy with the Environmental Protection Agency that would cover almost all U.S. construction projects, and every federally-aided infrastructure project. Hal Tufty, Value Engineering Now Included by EPA in Construction Grant Programs, *Professional Engineer*, v 45, n 6, Jun, 1975, pp. 36-38.

labeled them than the “aesthetic solution” to value engineering objectives that they became for the federal highway administrations’ structural engineers.<sup>112</sup> Respected for their design and construction management of bridge construction but also cognizant of the variable and diverse markets of the steel industry’s structural types, the Louisiana Div. of Highways (LADOH)’s choice of Frankland and Leinhard design engineers epitomized the Federal Construction Council’s definition of innovate engineers on the cutting edge of bridge technology. A foreign source (German) within North America, their market research of high-strength steel offered a perspective on bridge types<sup>113</sup> that stands an arm’s length from the “emotional public...[and]...belligerent press” surrounding the project by 1973.<sup>114</sup>

From a combination of qualitative opinions from the streets and expertise in measurable outcomes, feasibility studies for systems engineering of these long-span bridges serve up proof that functional values can become aesthetic values merely through the evaluation of structural types with the standards of a different value system for the bridge as a whole.<sup>115</sup> The mathematical models of total cost that feasibility consultants Modjeski and Masters derived for each of the structural types proposed by Frankland and Leinhard show that the potential to generate savings from designs of three bridge types in either the short- or long-run grows variably over the range of 1200

---

<sup>112</sup> *Newsweek*, 1968 is the only reference Paul Fosier, a bridge engineer, gives in the online journal of LA Division of Engineers, *Preconstruction Pages, A Publication of the LADOTD Preconstruction Project Development Division, Vol. 2, No. 1*, For more on the highway politics and public discourse concerning civil engineering projects in the New Orleans area at this time, see Tom Lewis’ *Divided Highways* (New York: Viking, 1997) and Richard Weingroff’s “The Battle of New Orleans-Vieux Carre Riverfront Expressway (I-410)” <http://www.fhwa.dot.gov/infrastructure/neworleans>.

<sup>113</sup> Frankland & Leinhard Consulting Engineers of NY supervised from 1942 onward the work of the Structural Stability Research Council of the Univ. of Missouri, specifically dealing with the structural problems of stability encountered in structural frames of high-strength steel and with research conducted in collaboration with the US Navy Dept. University of Missouri, Library Catalog.

<sup>114</sup> E. Stanley Jarosz, “Luling Bridge, :” Cable-Stayed Bridges, Structural Engineering Series No. 4 Bridge Division (Washington, D.C.: Federal Highway Administration, June 1978), pp. 219-221.

<sup>115</sup> Walter Podolny, Cable-Stayed Bridges presented at the AISC National Engineering Conference, Philadelphia, PA in May 1973, *Engineering Journal* (First Quarter, 1974), p. 8 (1-8).

ft to 2000 ft main span lengths considered for the two crossings (fig. 1.9). Notably, no cable-stayed bridges had been constructed in the U.S. as of yet, not even the pedestrian Menomonee Falls Bridge to be completed in 1971, let alone the fact that the main span lengths considered for the study had yet to be reached anywhere in the world by bridges supported solely by inclined cable stays. Comparisons of cost and form, technology and construction by “iterative analysis of geometry at every stage” of increasing the bridge types’ span to 1222 feet of the 4-lane highway made detailing the connection between technical and social system parameters too tedious a process of replacing obsolete bridge construction schemes with alternate ones of new technology that few computational methods available let alone known by practitioners could solve, according to LADOH project administrator Robert T. Kealy.<sup>116</sup> Even if they had employed these methods, such numerous revisions would not likely prove worthy of their cost given either one of these high-capital projects could be abandoned by interstate highway planner.<sup>117</sup>

Instead of iterative design techniques, feasibility consultants Modjeski and Masters ascribe values of total cost into their economic portrayals of a ‘cable-stayed bridge type,’ which the American engineers before them at the 1973 ASCE National Structural Engineering Meeting<sup>118</sup> had yet to define. A “cable-stayed girder bridge” in the technical and anecdotal writings on the development of cable-stayed bridges in the

---

<sup>116</sup> Robert T. Kealy, Feasibility Study of Mississippi River Crossings Interstate 410,” Meeting Preprint, 2003, ASCE National Structural Engineering Meeting, April 9-13, 1973, San Francisco, California. It is assumed this paper accurately reflects the ideas presented in the unavailable “Feasibility Study of Mississippi River Crossings Interstate Route 410,” a report to Louisiana Department of Highways with Cooperation with Federal Highway Administration, Modjeski and Masters, Consulting Engineers, Harrisburg, Pennsylvania, July 1971.

<sup>117</sup> The 6-lane Chalmette Bridge was in fact abandoned temporarily when the I-410 highway was scaled back due to communities’ revolt against the span’s alignment. Ibid.

<sup>118</sup> E. Stanley Jarosz of Frankland and Leinhard provided the thinking behind the selection of this unusual bridge type of unfixed form” is the interpretation of *Civil Engineering* editors in their recap of the engineers’ presentation “Design of the Luling Bridge” presented at the ASCE National Structural Engineering Meeting, Baltimore, MD, April, 19-13, 1971, pp. 1-11 in “Highlights of the ASCE National Structural Engineering Convention and Exposition,” *Civil Engineering*--ASCE, Vol. No. (June 1975), pp. 80 -81.



U.S. and abroad is the closest American civil engineers get to articulating the technological composition or cultural value of any structural type to their social development of the so-called “renaissance of bridge engineering” discussed two years earlier.<sup>119</sup> The economic prospects of this new form of steel bridge construction were as much undecided in terms of their impact on the composition of bridge constructions as the bridge projects themselves at this time. Even, an artists’ aerial rendering of the proposed Luling Bridge (fig. 1.10) sufficiently depicts the elemental forms of highway bridge structural systems—girder, deck, piers and towers—to compose the schematic that would not pull the bridge form’s away from the interstate grade (height and level) of highway geometry in the ex-urban space of Luling, Louisiana.<sup>120</sup>

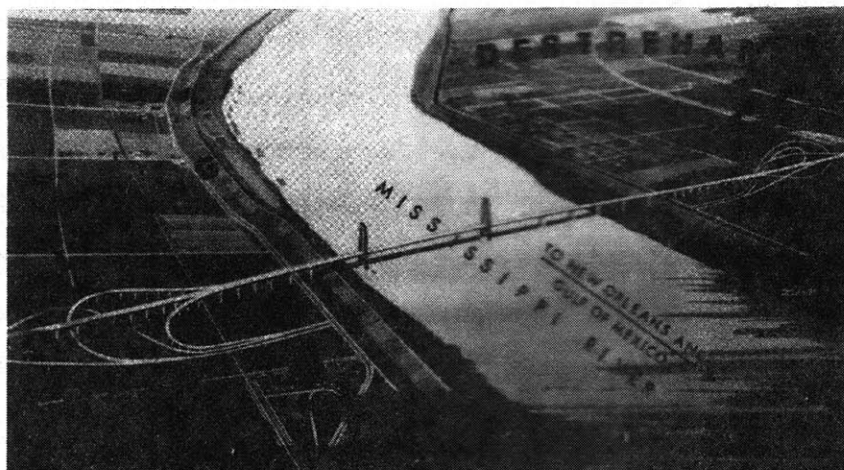

Fig. 1.10 Aerial sketch of the proposed Luling Bridge (E. Stanley Jarosz, *Cable-Stayed Bridges*, 1978)

<sup>119</sup> The first uses of ‘cable-stayed girder bridge’ is found in G.B. Godfrey,’s article “Postwar Developments in Germany Steel Bridges and Structures,” *Structural Engineer*, Vol. 35, No. 10 (October 1957), pp. 393 (390-398).

<sup>120</sup> *AASHO Standard Specifications for Geometric Highway Design*, ed. 1970 reported used by the LADOH to control the geometry of the cable-stayed bridge type’s form. Jarosz, “Luling Bridge,,” *Cable-Stayed Bridges*, Structural Engineering Series No. 4 Bridge Division (Washington, D.C.: Federal Highway Administration, June 1978), pp. 220.

The preliminary design of the cable-stayed bridge type nevertheless diverges and dips well below the “total costs” valued for the life cycles of both cantilevered and suspension bridges also economically evaluated in regards to the four- and six-lane highway spans. The feasibility of the “cable-stayed bridge type” depicted in the graph seems without basis relative to Modjeski and Masters’ assessment of cantilevered construction, which led them to recall that the industrial form selected for the New Newburgh Bridge (NY, 1980) “left little room [for them] to act” upon value analyses of component costs required for both projects. “All that could be done,” to allow new technologies of construction to take hold in the two bridges spanning over 1000 ft on their desks in 1970 is visibly distinct in the New Newburgh-Beacon Bridge’s cantilevered construction form (fig. 1.11) and the cable-stayed Luling Bridge planned to be constructed by cantilevered construction method. On the elemental level of both designs’ structure, however, is the new steel technology for tension members forming a space frame—U.S. Steel’s weathering steel. For selection of such an “unusual bridge type without fixed form”<sup>121</sup> to count—in federal audits for two bridges funded at 90%-10% federal-state funding, that is—bridge selection “must be contingent upon more than the benefits of new steel,”<sup>122</sup> Modjeski and Masters suggested as they handed over the structures’ design to Frankland and Leinhard. Total costs of acquiring the components of this new structural system would need to prove more economically valuable than the “original cantilevered truss”<sup>123</sup> structure built downstream by Modjeski and Masters in 1962 as the award-winning Greater New Orleans Bridge but called an “uneconomical structure in the Mississippi River Basin region of New Orleans” for the LA-DOH by 1973.

---

<sup>121</sup> Highlights of the ASCE National Structural Engineering Convention and Exposition,” *Civil Engineering*--ASCE, Vol. No. (June 1975), pp. 80.

<sup>122</sup> Jarosz, p. 121.

<sup>123</sup> Ibid.

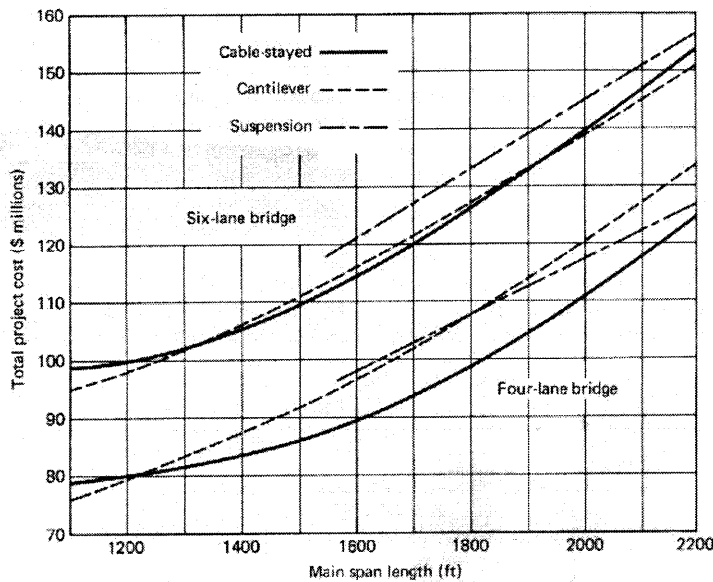

**Figure 1.11. Graph of Total project costs (\$ Millions) per foot of main span length for four-lane and six-lane bridges of the cable-stayed, cantilevered and suspension bridge types, Modjeski and Masters (Podolny and Scalzi, *Design and Construction of Cable-Stayed Bridges*, 1986)**

Further comparisons of the Luling Bridge structure with Modjeski and Masters' other cantilevered bridge constructions reveals their evaluation of cable-stayed bridges' viability—economic, social and cultural—rely upon evaluating the potential value benefits of an indiscriminate new system of building steel structural systems of cantilevered and cable-supported bridge construction for the I-410 highway system relative to the sure feasibility of both the cantilevered and suspension bridge types. As cable-stayed systems would replace the cantilevered steel flange system of support for cantilevered box girder highway bridges constructed in the 1950s, such as the Benton City Bridge (fig), these two crossings could take the form of "cantilevered concrete bridges with cable-stays" by the time construction was to be completed in the late 1970s.<sup>124</sup> With the shedding that a weathering steel bridge would evidently undergo over time, achieving aesthetic value through the cable-stay system would be necessary

<sup>124</sup> T.Y. Lin, Conclusion, Prestressed concrete segmental bridges: a compilation of papers presented at Prestressed Concrete Segmental Bridge Construction Seminar, Little Rock, Arkansas, October 26-27, 1978 compiled by Walter Podolny, Jr, Structural Engineering Series No. 6 (Washington, D.C. : Bridge Division, Office of Engineering, Federal Highway Administration, U.S. Dept. of Transportation : Federal Highway Administration, Office of Engineering, Bridge Division distributor, 1979)

to control the functional value of the project to materialize not only in value engineering studies of feasibility but in public review processes. The press for these high-profile bridge projects could easily mirror that of the U.S. Steel Headquarters building, built with their own new steel product, the Con-tek weathering steel, only for U.S. Steel to field criticism versus marketing dollars from both the architectural and engineering press about its “new direction” away from a streamlined aesthetic and towards a “return to texture” in structure.<sup>125</sup> On the other hand, selecting a material that proved “too rustic for the modern architecture of Max Abramovitz”<sup>126</sup> (architect of the U.S. Steel Headquarters building), Frankland and Leinhard would open the door for alternate designs of cable-stayed bridge construction which turn the post-modern critiques of Lewis Mumford and Jane Jacobs into proposals for a postmodernity that returns to the eclecticism of pre-modernity as Charles Jencks claims to in fact develop from such open-ended notions of a feasible and market-valuable structure of any type of building in the 1980s.<sup>127</sup>

Questions like “what is the cost?” and “what is the function?” were supposed to set the problem to be solved by value engineering type selections not create new problems for subsequent study, but neither structural engineers of Modjeski and Masters nor Frankland and Leinhard would take the techniques of evaluation offered by FHWA officials and industry know-how available to them both at face value. Whether the savings realized surpass the effort expended always remains a question even if it does keep the designers alert [to economic issues],<sup>128</sup> structural engineers E. Stanley Jarosz commented to colleagues considering the application of such value engineering methods of pushing concrete construction in civil engineering culture. Ultimately, these structural engineers would conclude, however, that value engineering was useful to

---

<sup>125</sup> “Big Steel Spike: the U.S. Steel Building is a Symbol of both an Industry and a city,” *Architectural Forum*, vol. 135, no. 5, (Dec 1971), pp. 25 (24-29).

<sup>126</sup> “Conclusions,” T.Y. Lin, ed. *Segmental Concrete Construction*, A Conference held in 1969 (Washington, D.C.: FHWA, 1969), p. 209.

<sup>127</sup> *The Post-Modern Reader*, ed. Charles Jencks (New York: St. Martin’s Press, 1992).

<sup>128</sup> *Ibid.*

their specific efforts at it is “certainly could achieve economy under certain conditions” of market competition.

## Chapter 2: Cost and Geometry Control of Cable-Stayed Bridge

### Projects

*“The inventiveness and creativeness of the Operations Research team and the sponsoring organization are the only real limit to the form and extent of the alternatives...it is in this phase of the project that policy content is developed.”<sup>129</sup>*

*(Alan Altschul, Transportation and Community Values, 1969)*

With the potential to “obtain optimum value for every construction dollar spent in the 1970s”<sup>130</sup> lurking over the heads of state and federal highway administrators, it is no surprise that contractors consulting on interstate highway bridge administrators were the first segment of the civil engineering community to discuss how value engineers’ strategies and goals were aligned with their responsibilities for project, bridge and design selection. If the cost and geometry of construction materials, practices, components, technology and labor policies were controlled by project selection, fellow state highway officials charged with approving interstate bridge plans would possess the power to manage bridge type selections as capital investments in innovation not just productivity. Even the American Management Association recognized “management of infrastructure project decisions”<sup>131</sup> to be a pressing issue of their discipline as they discussed the possible application of MBAs to civil engineering and urban planning at their 1970 Convention. How different types of sociotechnical systems structure the economic vitality of the construction industry as well as federal

---

<sup>129</sup> Altshuler, Alan, “The Values of Urban Transportation Policy,” Conference on Transportation and Community Values, *HRB Special Report 105*, pp. 75-86, 1969. Churchman, C.W., Ackoff, R., and Arnoff, E.L. *Introduction to Operations Research* (New York: John Wiley and Sons, 1957).

<sup>130</sup> Macedo, et. al., *Value Management for Construction* (New York: John Wiley and Sons, 1978), p. 19.

<sup>131</sup> William Falcon, ed., *Value Analysis, Value Engineering and the implications for managers*, (New York: AMA, 1964), AMA Management Report No. 81, p. 34.

programs led ultimately to an offer of “management muscle”<sup>132</sup> from the editors of the *Harvard Business Review* to ensure construction processes, if not the designs mitigated by those processes, yielded to the ebbs and flows of industry and prevailing economic conditions.<sup>133</sup>

Such methods of social control were not necessary; consulting engineers still controlled “the job that is to be done, the budget to do it, the schedule on which it is to be done and the labor content and materials in the final product cost,” as the FHWA’s director of VE training reminded civil engineers assigned to controlling costs generated by design, construction and maintenance of bridge selections.<sup>134</sup> With alternate designs and construction schemes, value control would materialize from selection of one of a number of alternative systems. To commission a valuable bridge that federal officials would approve to replace Benton County Washington’s 53-year old Pasco-Kennewick Bridge (1921, fig. 2.1) with a new, more economical structure required not collaboration between consulting engineers and federal officials but the cooperation of bridge engineer Arvid Grant and his consultants in the creation of a decidedly economical structure representative of the state of the art of the structural systems in the bridge construction marketplace.<sup>135</sup> Even for this bridge project landing beyond metropolitan Seattle’s city lines in the ex-urban spaces of Washington’s regional development areas, cost increases coincident with increases in span length were not taken lightly in terms of their impact on total project value.

---

<sup>133</sup> Report on Value Engineering, American Management Association, 1969; Proceedings from the 1970 Convention of the AMA, 1970.

<sup>133</sup> Report on Value Engineering, American Management Association, 1969; Proceedings from the 1970 Convention of the AMA, 1970.

<sup>134</sup> Tufty, “Controlling Design, Construction, and Maintenance Costs to Combat Inflation,” *Civil Engineering*, October 1981, p. 46.

<sup>135</sup> Arvid Grant, “Pasco-Kennewick Bridge—the longest cable-stayed bridge in North America,” *Civil Engineering—ASCE*, Vol. 47, No. 8 (August 1977), p. 66.

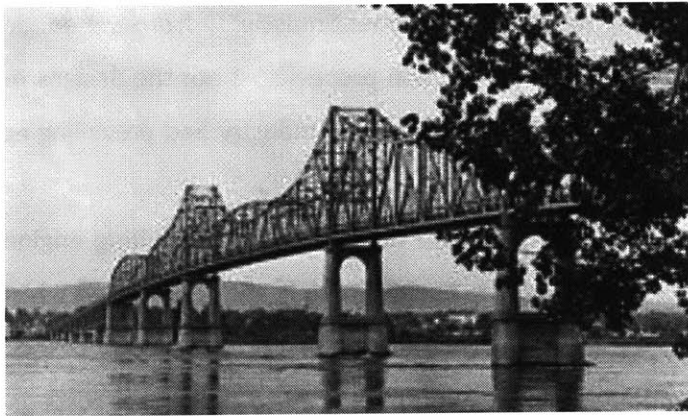

**Figure 2.1 Pasco-Kennewick Intercity Bridge, 1922, WA (Historic American Engineering Record)**

The potential effects a unit price rate hike has on the economic cost of one versus four alternative designs for each of these spans opens the door to a technologically workable system, ultimately, one which the WA-DOH would select and implement with technology available in 1975 when the technical details and other priority conditions of their bridge type selection became a reality. Selecting only one design for the bridge's main span of 981 ft, side spans of 413 ft and approach spans of 45 feet would otherwise force the federal and county governments (the market) to absorb the inflationary changes in the marketplace. For example, consumers buying one apple at \$1.00 after a 'mark up' (or inflation in cost) of \$0.50 put them "on sale" at 3 for \$2.00. As graphed by structural engineers to guide state highway officials' selection of bridge type selection parameters versus the bridge types themselves (fig. 2.2),<sup>136</sup> the effect of the interest rate increases in the 1970s on the economic value of their project costs would only increase in market value (the equivalent uniform annual transportation costs) relative to scenarios where more than one design was alternatively evaluated. The 1800 ft crossing planned for the Columbia River equaled more than 50% the total length of the Hawkshaw Bridge and the Papineau Bridge in Montreal, Canada, completed in Canada in 1969 and exactly four times the length of the Sitka-Harbor Bridge built in Alaska just a few months prior to Grant reporting his preliminary designs

---

<sup>136</sup> *Value Engineering for Highways* (Handbook), 1980 rev. ed. (Washington, D.C.: FHWA, 1980).



for the Pasco-Kennewick project to the Washington Division of Highways (WA-DOH). For every unit increase of the interval bridge spans, however, a uniform comparative framework for evaluating construction scenarios developed for the numerous alternate designs for deck, girder and even cable arrangements supporting each span. Slicing girder and deck components as well as cable spacing into *increases* and *decreases* more in step with the steel and concrete industries' conception of bridge span allows erection and assembly configurations to result in construction schemes unparalleled in number by the optimized number of alternate wall panel and floor assembly systems previously presented to federal officials.

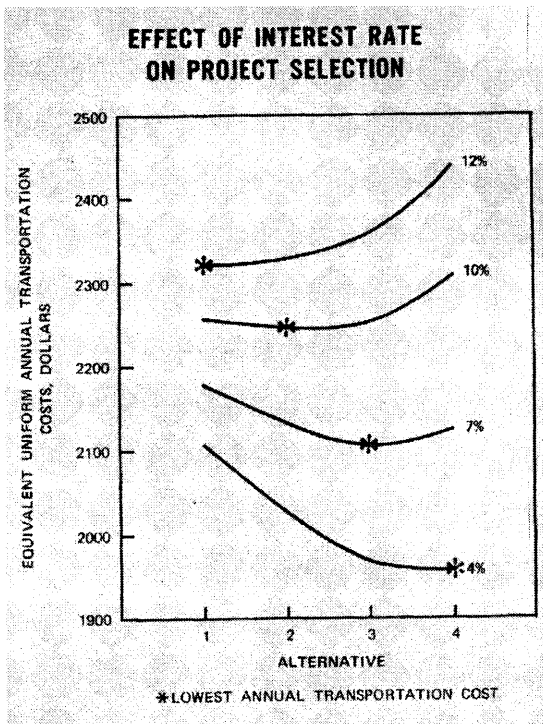
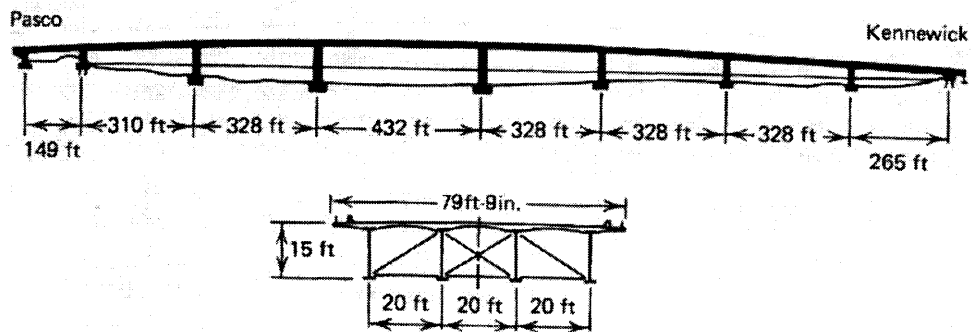

Figure 2. Equivalent Uniform Annual Transportation Costs (Dollars) for four alternative bridge projects, the lowest annual costs being determined for each based upon the interest rates of 4,7, 10 and 12%. (*Value Engineering for Highway*, FHWA, 1980)

Perched on the banks of the Columbia River, the existing Pasco-Kennewick Bridge offered an original design not unlike the Greater New Orleans Bridge for which Arvid Grant and Associates could develop that counter steel truss bridge structure with commercial construction building systems and techniques of cantilevered construction. In place of this historical data for design of the new intercity bridge, Arvid Grant looked

to projections of the relative costs between structural systems with and without cable-stays, built and unbuilt, to serve as the basis for engineering value from construction schemes—starting with the simplest highway bridge geometry defined in the American Association of State and Highway Officials’ geometric standards (fig. 2.3 and fig. 2.4). Even for this bridge to land beyond the metropolitan lines of an urban Washington area, the increases in span length and renewal of bridge technology pose a significant impact on total project costs to be financed 85% by the federal highway administration for the regional development plans of Pasco and Kennewick city councils.<sup>137</sup> To facilitate the research of new construction methods and systems building techniques to employ with such innovative construction methods of incremental launching, where span segments are pushed into place from the tower, Arvid Grant consulted Fritz Leonhardt, a renowned bridge engineer and aesthetic critic of Leonhardt and Andra Partners in Stuttgart, Germany.



**Figure 2.3 Alternate #1 for the Pasco-Kennewick Intercity Bridge—the most complex section arrangement for bridge girder (from *Design and Construction of Cable-Stayed Bridges*, 1978)**

<sup>137</sup> Arvid Grant, “Pasco-Kennewick Bridge—the longest cable-stayed bridge in North America,” *Civil Engineering—ASCE*, Vol. 47, No. 8 (August 1977), p. 62-3 (62-66).

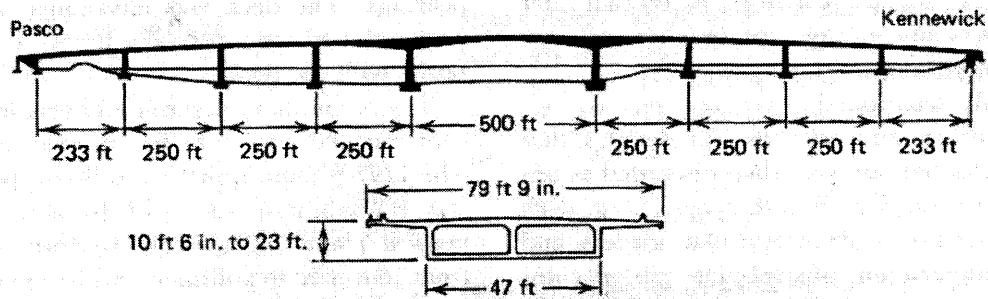

**Figure 2.4 Alternate #3 for the Pasco-Kennewick Intercity Bridge—the most uniform in both longitudinal and transverse dimensions of bridge girder sections from the Preliminary Report for the Pasco-Kennewick Intercity Bridge (Podolny and Scalzi, *Design and Construction of Cable-Stayed Bridges*, 1978)**

Distinct from the proposal process of (West) Germany’s Alternate Design Program, which required that a market design with “comparative material efficiency”<sup>138</sup> be compared to the original designs of their state engineers, the American alternate design policy forming in the Federal Highway Administration yields credit financially and culturally for the systematic solutions that control geometry with value engineering.<sup>139</sup> Following exactly the instructions most recently set forth by the Environmental Protection Act for design-phase engineering as part of “socioeconomic impact assessment,”<sup>140</sup> Arvid Grant and Associates (AGA)’s economic evaluation of the five alternate designs they consider harks back to “documentation of concurrence on competition between alternate designs” in the construction industry, which in turn project forward the costs of cable-stayed construction to an alternate future. These assurances that valuation would satisfy quantitative and qualitative measures of measurable outcomes not only prepare these design proposals for federal review but

<sup>138</sup> Fritz Leonhardt, “Alternate Design and Engineering Development,” *Cable-Stayed Bridges, papers presented at the conference held in Pasco, WA, 1978*, Structural Engineering Series No. 4 (Washington, D.C.: FHWA Bridge Division, June 1978), p.7.

<sup>139</sup> Hal Tufty, “Value Engineering Now Included by EPA in Construction Grant Program,” *Professional Engineer* (Washington, D.C.: Vol. 45, No. 6 (June 1975), p. 36 (36-38)

<sup>140</sup> The entire text of *Provisions for Value Engineering* in this EPA Program can be found in Dell’Isola’s *VE in the Construction Industry*, Appendix B.

throw into question the economic ratios of total costs they articulate for each alternate design (fig. 2.5).

Alternate	Description	Cost Ratio
1	Steel plate girder	1.005
2	Cable-stayed concrete box girder	1.000
3	Concrete box girder—push-out method	0.952
4	Concrete box girder—cantilever method	0.981
5	Cable-stayed steel box girder	1.019

**Figure 2.5 Economic Comparison of Cost-Value Ratios for the 5 alternate designs evaluated in AGA’s Preliminary Report for the Pasco-Kennewick, 1971 (Podolny and Scalzi, *Construction and Design of Cable-Stayed Bridges*, 1978)**

Despite conjectures that economic ratios of construction costs ground economic analyses of preliminary design studies in the present more so than analysis of equivalent uniform annual costs in feasibility studies,<sup>141</sup> Grant and Leonhardt’s economic evaluation of cable-stayed systems of construction repeats speculation on market conditions that Modjeski and Masters conducted a year earlier.<sup>142</sup> With the construction methods for orthotropic (fully welded) steel decks and precast segmental concrete decks still emerging on the bridge construction market as of the late 1960s, Leonhart saw the potential for cable-stayed bridge systems to compete against suspension bridge designs for spans in excess of 2000 ft, possibly 5000ft as well, along with the rise of approval and standards for their structural systems’ use in U.S. highway building.<sup>143</sup>

<sup>141</sup> Macedo, et. al. p. 42.

<sup>142</sup> Grant, “Pasco-Kennewick Bridge: Longest Cable-Stayed bridge in North America,” p. 66

<sup>143</sup> Arvid Grant and Fritz Leonhardt make these claims in separate articles while working together and specifically in reference to this bridge as a representative case for the longer spans, Arvid Grant in “The Pasco-Kennewick Bridge—the longest cable-stayed bridge in North America,” *Civil Engineering—ASCE*, Vol. 47, No. 8 (August 1977), p. 64 (62-66) and Fritz Leonhardt, “Future of Cable-Stayed Bridges,” *Cable-Stayed Bridges*, Structural Engineering Series, No. 4 (Washington, D.C.: FHWA, June 1978), p. 308 (304-318). Leonhardt, F. and Zellner, W, “Cable-Stayed Bridges: Report on Latest Developments,” *Proceedings of the Canadian Structural Engineering Conference, 1970*, Canadian Steel Industries Construction Council, Toronto, Ontario, Canada. The

Conversely, when members of the British Steelworkers Association asked “can steel bridges become more competitive”<sup>144</sup> with the extension of the cable-stayed system’s capacity to the suspension bridge’s territory, the former German engineer of Autobaun development responded with his own surety that “it is highly unlikely or unrealistic to build bridges with very long spans using cable-stayed construction.”<sup>145</sup> Charting what he deemed to be the appropriate range of span proportions for each bridge type on the market in fixed boxes anecdotally reveals his disbelief in sweeping market moves’ ability to impact the growth and decline of bridge types in bridge engineering culture (fig. 2.6) to become clear in his analyses’ juxtaposition with later market research for the in industry.

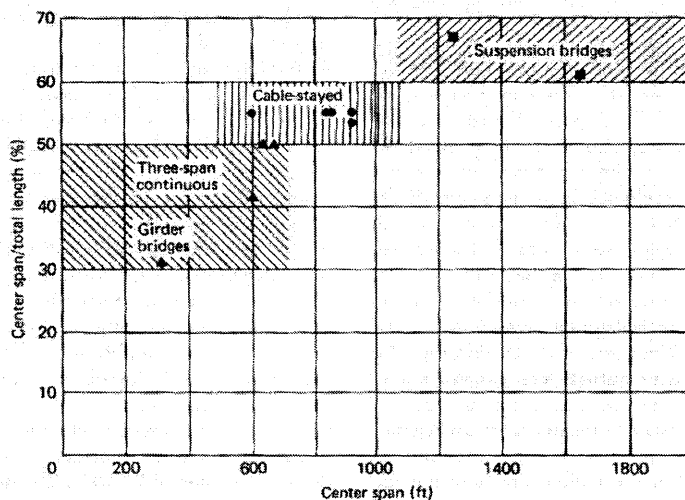

**Figure 2.6 Thul’s depiction of span segment proportionality for three-span continuous girder, cable-stayed and suspension bridge types (Thul, British Structural Steelworkers Association, 1967)**

latter possibility of 5000ft span cable-stayed bridges was concluded earlier by Leonhardt in his and Zellner’s paper before the International Association for Bridge and Structural Engineering in 1972 (IABSE Bulletin 32, 1972).

<sup>144</sup> P. Elliot, “Can Steel Bridges Become More Competitive,” *Proceedings of the Conference on Steel Bridges* (London: The British Steelworkers Association, Ltd, 1968).

<sup>145</sup> H. Thul, “Cable-Stayed Bridges in Germany,” *Proceedings of the Conference on Structural Steelwork* held at the Institution of Civil Engineers, September, 26-29, 1966. (London: The British Constructional Steelwork Association, Ltd, 1967), p. 6.

At the start of the Pasco-Kennewick Bridge project, “soon to be released data on highway bridges between 700 and 800 feet spans in Canada finally recognized the application of German developments to the Americas,” Fritz Leonhardt noted in the support he received for testing scaled models for final designs of the Pasco-Kennewick in Vancouver from Walter Podolny and P.R. Taylor, senior ranking structural engineers with the U.S. and Canadian highway administrations respectively.<sup>146</sup> P.R. Taylor, a bridge engineer and founder of structural engineering firm Buckland and Taylor, reported to the Canadian Structural Steelworkers Association that, with orthotropic box girders that attach to the towers rather than deep water piers, the value of incrementally dividing up the deck and girder spans of bridge superstructures into segmental components rise as the costs of foundation work plummets (fig. 2.7).

Contractors’ move towards segmental construction methods and equipment and the structural systems that require them at the expense of the foundation engineering market for traditional pier-supported spans and others reveal the value to future plans marks the economic difference between these market trends in the North American construction industry, Taylor concludes.<sup>147</sup> The market value of bridge types depicted in Taylor’s curves for the cable-stayed bridge thus reveals the opportunity costs of not choosing the cable-stayed bridge type over one of the others with a higher unit market value. The present value, or worth, of a type of structural system in this marketplace provides an estimate of total costs for each alternative option; however, by the time the opportunity desired comes along, this true value of market conditions is no longer true nor does it serve the role of truth that economic knowledge conventionally provides in engineering studies.

---

<sup>146</sup> Fritz Leonhardt, “Future of Cable-Stayed Bridges,” *Cable-Stayed Bridges*, p. 305.

<sup>147</sup> P.R. Taylor, “Cable-Stayed Bridges and Their Potential in Canada,” *The Engineering Journal* (Canada), Vol. 52, No. 11 (Nov. 1969), pp. 15-27.

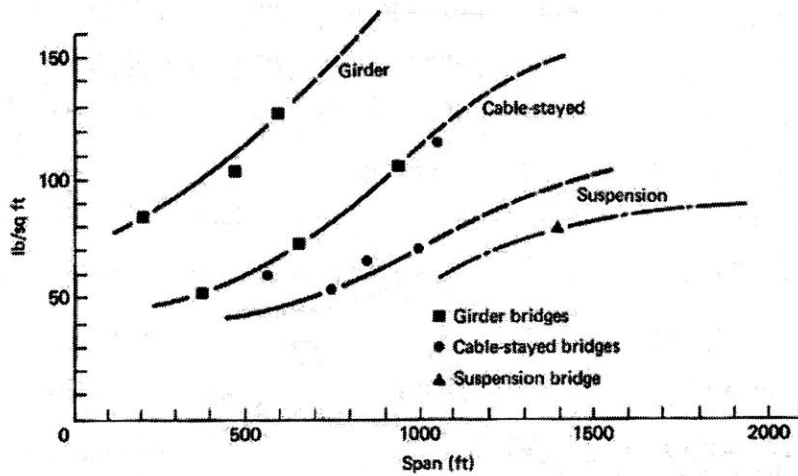

Figure 2.7. Steel Consumption per Increment in Main Bridge Span Length of Girder, Cable-Stayed and Suspension Bridge types (P.R. Taylor, Canadian Engineering Journal, 1969)

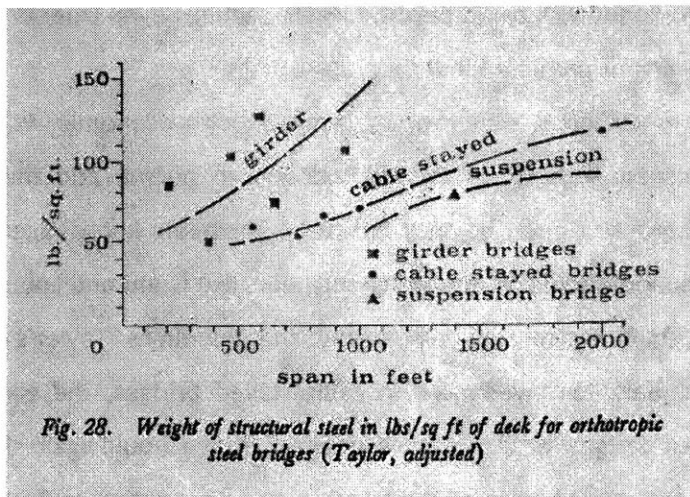

Fig. 28. Weight of structural steel in lbs/sq ft of deck for orthotropic steel bridges (Taylor, adjusted)

Figure 2.8. "Weight of structural steel in lbs/sq ft of deck for orthotropic steel bridges" of the girder, cable-stayed and suspension bridge types (Podolny, AISC Engineering Journal)

Because none of the parameters for market conditions in Taylor's study were documented for future analysis, recognizable data points for recent projects in Taylor's curves could adjust with the justification that "different interpretations could be drawn from Taylor's curves."<sup>148</sup> According to FHWA Bridge Engineer Walter Podolny,<sup>149</sup> different projects with more favorable dates and components for federal officials or contractors' notion of competitive construction schemes for a single structural type could be substituted. For instance, with no relationship to any of Canada's highway building, the Dusseldorf Kniebrücke (Knee Bridge over the Rhine River), which is plotted at 1690 ft and just over 100 lbs/sq ft on Podolny's graph of Taylor's curve (fig. 2.8)," bends the curve depicting cable-stayed bridge designs' value in the orthotropic steel deck market towards the suspension bridge's territory and away from that of the girder bridge to which it nears in the actual Taylor curves. With this logic of industry data, before the paperwork for savings due to Grant and Leonhart's value engineering traveled through the bureaucracy of federal approval, contractors' bids on the construction of the Pasco-Kennewick could become viable perhaps even true, like costs of maintenance materializing as projected in total project costs.

Bids for further recent cable-stayed bridge projects with economic values of construction costs offer new trajectories for the industry to pursue and thus new decisions for authors of industry data, be they industrial engineers knowledgeable of contemporary market economic logic or consulting engineers like Grant and Leonhardt.. If above the \$110.00 per sq. ft. of superstructure surface that Podolny's "Taylor's curves, adjusted" make a benchmark for investment in cable-stayed bridges, the economic evaluation of cable-stayed designs for the Pasco-Kennewick Bridge would again shift the data. Soviet engineer E. Dubrova showed at the International Association of Bridge and Structural Engineering Conference in New York the previous year, that switching a preliminary design's structural system from steel girders with some concrete deck

---

<sup>148</sup> Walter Podolny, Jr., "Cable-Stayed Bridges" presented at the Convention of the American Institute of Steel Construction, Aug 1974, *Engineering Journal*, (1975), p. 8 (1-9).

<sup>149</sup> Ibid.



reinforcement to concrete girders and deck with steel reinforcement earned designs of cable-stayed bridge construction under consideration at the time greater value relative to their counterparts with less flexibility to yield to conditions of the prevailing marketplace for concrete and steel girders (fig. 2.9).<sup>150</sup> For instance, the single mast steel bridge construction that Arvid Grant eliminates in value analysis of girder bridges (fig. 2.10) brings Podolny's economic analysis of the cable-stayed bridge market into the functional territory of the classical suspension bridge type—a selling point for adopting cable-stayed bridges to the building technologies of long-span bridge construction Grant and Leonhardt support.<sup>151</sup>

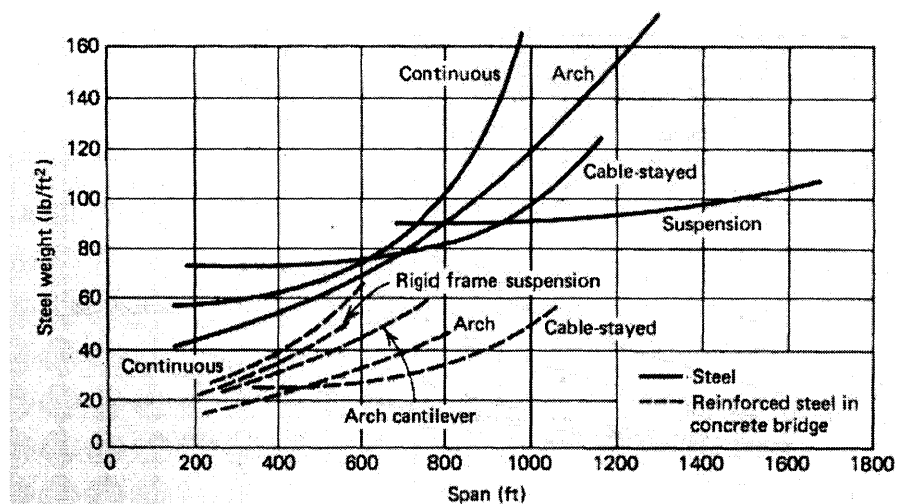
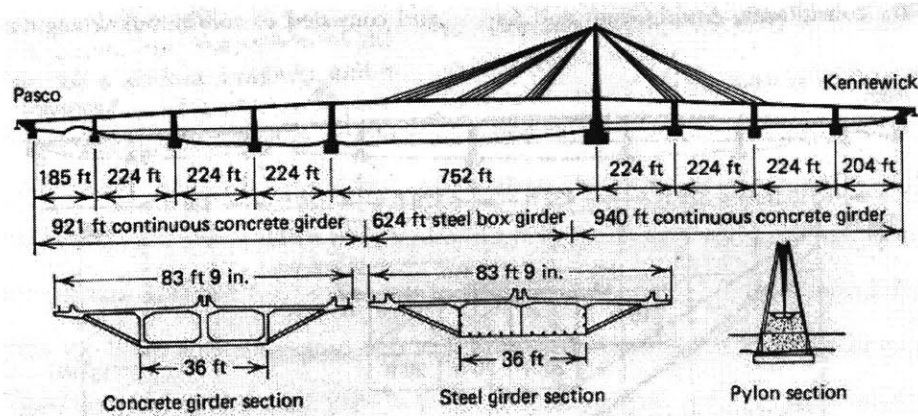

Figure 2.9. Weight in lbs/sq.ft steel structure (solid lines) and steel reinforcement for concrete bridges (dashed lines) for various bridge types (E. Dubrova, *IABSE Bulletin*, 1972)

<sup>150</sup> E. Dubrova (USSR), "On Economic Effectiveness of Application of Precast Reinforced Concrete and Steel for Large Bridges," International Association for Bridge and Structural Engineering, *Bulletin 28*, 1972.

<sup>151</sup> Podolny, "Economic Evaluation of Girder Bridges," *Highway Focus*, ed. Walter Podolny (FHWA: U.S. Office of Government Printing, May 1973).



**Figure 2.10. Alternate #5: cable-stayed design of a hybrid concrete and steel girder supported by a pylon (Grant, from *Design and Construction of Cable-Stayed Bridges*)**

This relativity for value analysis of preliminary design costs explain why Grant and Leonhardt provided no graphs to accompany their own ratios of total costs adjusted for the marketplace of specialty contractors who provided the comparative framework for evaluating their alternate designs' three erection methods (incremental launching, the push-out method, and hydraulic lifting of span segments). Each of these techniques of industrial erection "emerging in the U.S. construction industry"<sup>152</sup> as of 1970 when Grant prepares to submits these designs and evaluations to the WA-DOH had already been developed in analytical studies as a means to conceptually assemble structural systems for bridges and other structures in preparation for the real-world physical context. Structural engineers Frank Baron and Lein Shen-Ying of UC-Berkeley concluded in 1969 from their analytical "game scenarios"<sup>153</sup> of systems building for assembly and erection of the cable-stayed Southern Crossing that selection whose geometry strayed as far from the Cartesian grid of the San Francisco Bay Bridge would project through the

<sup>152</sup> T.Y. Lin, "Conclusions," ed., *Segmental Concrete Construction*, papers from the conference held by the FHWA in Dec. 1969 (Washington: D.C., FHWA, Office of Engineering and Development, Bridge Office, 1969), p. 208.

<sup>153</sup> Frank Baron and Shen-Ying Lien, *Analytical Studies of a Cable-Stayed Girder Bridge*, *Computers & Structures*, Vol. 3, (Pergamon Press, 1973), pp. 444-5 (443-465). The cable-stayed girder bridge discussed in the study is the analytical forms they contributed to analysis of the Southern Crossing of the San Francisco Bay Bridge, p. 443.

nonlinear structures of incremental launching sequencing the cable-stay system's cultural as well as functional value of into the economic feasibility of various scenarios for the bridge's construction not just one bridge type.<sup>154</sup>

AGA construction engineers even employ FAST diagramming of their value management of alternate designs geometry to appeal to discuss their "Erection Planning in Design"<sup>155</sup> of the Pasco-Kennewick Bridge to their colleagues at the 1<sup>st</sup> U.S. Conference on Cable-Stayed Bridges. Specifically, they discuss how the iterative design methods of systems engineering yield at each node and turn in the erection sequence and construction scheme for the analytical structure the functional as well as aesthetic values determined by the 'ratings matrix' for the bridge's overall system design. Just as UC-Berkeley, architect-engineers' intended their School Construction Systems Building Designs to be executed, the sequence and the scheme of systems building connects engineers' design decisions with the economics of the construction industry's erection methods not the costs of components interchanged by those methods. In essence, the epistemology of Grant and Leonhardt's creative engineering of a cable-stayed bridge with two structural systems combined into one girder component (fig. 2.11) meets its match in the methodology of planning and management of systems building.

---

<sup>154</sup> Ibid. 444-6 (443-465).

<sup>155</sup> "Erection Control: Pasco-Kennewick Intercity Bridge," *Cable-Stayed Bridges, papers presented at the conference held in Pasco, WA, Dec. 1978* (Washington, D.C: FHWA, 1978), p. 133, (133-145).

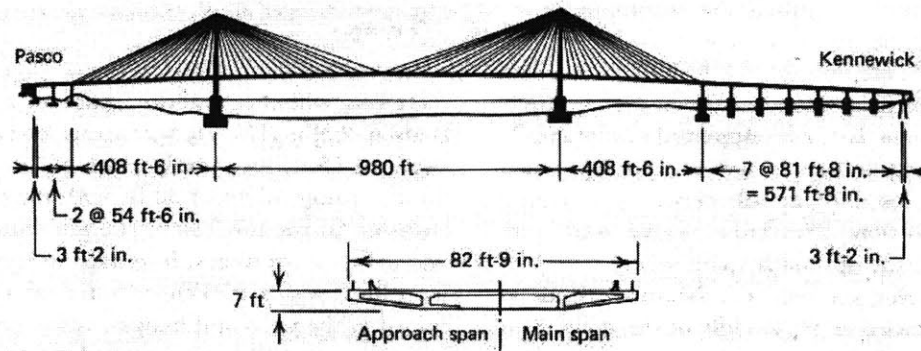

Figure. 2.11 The “cable-stayed bridge type” recommended by AGA to WADOH & FHWA for the Pasco-Kennewick Intercity Bridge

With the potential for growth in cable-stayed systems’ application to numerous types of structural systems comes the opportunity for savings, but only if market conditions are figured into one’s vision of project development with the number of alternatives, ranges of costs and points in time for evaluation are networked into a conception of a preliminary design’s place relative to a flexible yet defined project related to other projects in the marketplace for highway building (fig. 2.12). Without this conceptual framework guiding preliminary studies of highway bridges back towards the question of whether the selection is a design of functionality for economically feasible technologies, efforts to produce multi-functional construction schemes may become lost in the aesthetic theories that develop specifically for these computational structures. In fact, engineers begin referring to these diagrammatic and schematic forms with the term “architecture” in 1971 well before architectural culture picks up media of information exchange in the 1980s.<sup>156</sup>

Moving in this trajectory as well are the proliferation of a chart for “basic cable arrangements” (figure 2.13), which John B. Scalzi, an Industry Liason for the Dept. of Housing and Urban Development, in fact initially configured as the mathematical product of single through multiple cable-stay systems developed in the cable-supported

<sup>156</sup> Baron, F. and Lien, S.Y., “Analytical Studies of a Cable-Stayed Girder Bridges,” *Computers & Structures*, Vol. 3 (New York: Pergamon, 1973), pp. 443-463.

structures industry. Representing options for design standardization versus design exploration of emergent technologies refashioning of the cable-stay matrix exemplifies how the watchful eye of individuals and organizations in charge, invested or in support of value engineering must remain their presence to ensure the opportunity costs of these schematic forms to change with rather conform to new industry developments pan out in building culture as well as in economic scenarios of the future.

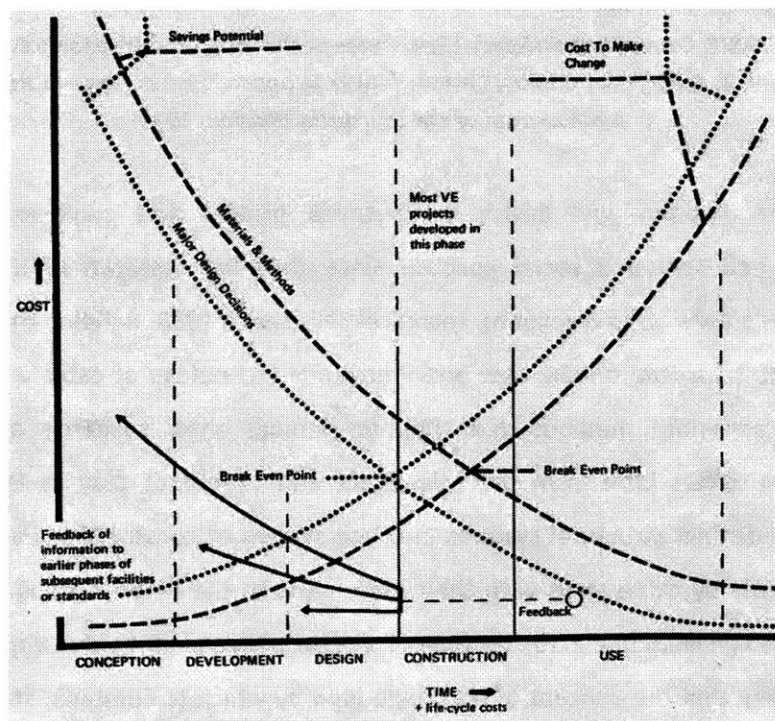
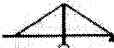





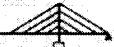







Figure 2.12 "Relation between savings potential and time in facilities construction," (Dell'Isola, *Value Engineering in the Construction Industry*, 1974)

Single	Double	Triple	Multiple	Combined	
					Radiating
					Harp
					Fan
					Star

**Figure 2.13 ASCE Committee on Special Structures of the Structural Division's Committee on Metals (John B. Scalzi, ed. Podolny, Chrmn. "Cable-Supported Structures—State of the Art," ASCE *Journal of the Structural Division*, 1971)**

To both Podolny and Scalzi, cable-stayed bridges and cable-supported roof structures had served a social purpose since they led research in the U.S. Steel Corporation's Division of Marketing Technical Services in 1968. Building the social value of contractors focused on the new and innovative technology of cable anchorage and long-span assembly methods (i.e. post-tensioning) their research at U.S. Steel Corporation differs little from the role Grant and Leonhardt play as they integrate completely distinct structural systems into one system of construction each supported independently by cable stays with their own paths to the pylon holding together the alternate design No.5 (fig. 2.10). Because of this social agenda for value engineering, it is not surprising that the concept of no bridge type by which to combine state-of-the-art structural systems and assembly sequences allowed for an asymmetrical span arrangement of two different materials and even an asymmetrical deck design for the bridge's superstructure to come into play for Grant and Leonhardt's search for least cost and maximum function over time (Figure 2.14). By Arvid Grant's admission,<sup>157</sup> the hybrid

<sup>157</sup> Arvid Grant, "Pasco-Kennewick Bridge—the longest cable-stayed bridge in North America," p. 66.

structure of multiple structural systems emerged as a new “bridge type”<sup>158</sup> by the end of their study, drawing attention away from the fact that cable-stayed bridge design—not a cable-stayed bridge type—framed all of their decisions regarding the formation of alternate designs with the state of the art of the bridge construction industry.

A “search for technical structural complexities”<sup>159</sup> to incorporate into the selection process, alternate design by way of cable-stayed design of hybrid construction systems allows cable-stayed bridge selections to appear unquestionable in value compared to other bridge types. Holding the prized position of the base value in tables specifically for “cost ratios”<sup>160</sup> whenever evaluated for a major bridge project of this time, but notably in this case of Arvid Grant and Associates report to the WA-DOH and the Sitka-Harbor Bridge reviews (figure 2.2 and 2.14), it is impossible for those outside the internal networks of collaboration on value control to discern the position of a cable-stayed bridge selection or the hybrid bridge type in the broader landscape of bridge engineering economics. Selection of a half-through tied-arch, considered for the Sitka Harbor Bridge site since 1961 and considered by Alaska-DOH engineers to be “probably the strongest competitor of the cable-stayed scheme at the time,”<sup>161</sup> could be presented as 9.5% more economical than the plate girder bridges evaluated 6.66% more economical than the cable-stayed girder bridge selected—only in the chart William Gute and design team use to inform of their “deciding on the best bridge design” for the Sitka-Harbor Bridge (fig. 2.14). With a similar simple switch of the “cable-stayed girder scheme”<sup>162</sup> that holds the base value of 1 in ratio calculations for the Pasco-Kennewick Bridge project, the steel plate girder possessing the closest value to the cable-stayed concrete box girder can appear to be more economically worthy of selection though Grant and Leonhardt considered it to be the original design with which to begin

---

<sup>158</sup> Ibid.

<sup>159</sup> Ibid.

<sup>160</sup> Ibid, p. 63.

<sup>161</sup> William L Gute, First Vehicular cable-stayed bridge in the U.S.,” *Civil Engineering—ASCE*, (Nov. 1973), p. 54.

<sup>162</sup> Ibid, p. 54.

questioning the cost of greater functionality available in “state of the art engineering methods and technology”<sup>163</sup>

I	Plate girder with fenders	1.15
II	Plate girder continuous	1.13
III	Orthotropic box girder	1.04
IV	Through tied arch	1.04
V	Half through tied arch	1.06
VI	Cable-stayed box girder	1.00

**Figure 2.14 Results of the economic evaluation of costs for Schemes I – VI of the Sitka-Harbor Bridge (WA, 1972) (from “First Vehicular cable-stayed bridge in the U.S.” CE, ASCE)**

Evidently, outside of these charts and the minds of the evaluators, these analyses of decision-making concerning bridge type selection possess only cultural value and fodder for conventional engineering judgment. In cultural discourse, Gute’s chart supports their the design team’s adamant stance on having “chose”<sup>164</sup> the cable-stayed girder bridge type but also serves as evidence one may not have done enough to research, solicit, or collaborate with industry on acquiring the most economical technology for structures. Provided speculatively in industry data, the relationship between cable-stayed bridges and other bridge type selections arising from alternate designs schemes relevant to industry data takes on the monetary values of an industry’s market, where at least market values can be determined by the nonlinear mathematical models of present and future values and then used in cultural debate. When the economic value of a type of bridge construction remains articulated on the scale of 0 to 1, the type selections as supposed to the actual bridge designs can only be valued within social networks in which these values possess worth—and only as long as the basis for these cost-value relationships remain true.

The latter scenario develops as Walter Podolny Jr. began conducting independent economic evaluations of preliminary type selections that question whether weathering steel amongst other technologies should have been employed in major bridge

<sup>163</sup> Grant, p. 66.

<sup>164</sup> Ibid., p. 50.



construction sooner, with the Sitka-Harbor Bridge<sup>165</sup> and both the Luling Bridge type selection and Chalmette Bridge project selection which preceded its construction as examples of missed opportunities. For the latter, the graphic depiction of more economical designs of the girder bridge type for spans outside the 1000 ft to 2000 ft range revealed Modjeski and Masters' consideration of cantilevered bridge construction accurate for all 6-lane highway bridges in the U.S. but "perhaps too aggressive" for the 4-lane highway construction scenario since the cable-stayed girder bridge type's feasibility had not yet been tested on short-spans. "The flood of responses that Podolny's studies produced at the ASCE National Structural Engineering Convention and Exposition the year he edits an issue of *Highway Focus* (1973)<sup>166</sup> reveal the dearth of any type of decision analysis for cable-stayed bridge selections besides case-studies of cable-stayed bridge projects in Africa, the Middle East, Asia, Latin America, and both Eastern and Western Europe found in industrial texts like the *Steel Designers' Handbook* (Wiley & Sons, Inc.) and *Design of Steel Structures* (McGraw-Hill).<sup>167</sup>

In the application of such a versatile style of decision analysis and useful form of speculation on bridge technology, the true intentions of industry partners and their data are revealed as well. To stimulate market growth through professional partnerships that would increase the market for *all* steel components in construction of cable-stayed highway bridges prevents the steel industry's declining market share of construction in the intermediate span length of 500 ft to 1000 ft to continue to decline. Rather than fight for more market share, American institutions of steel construction could take advantage of market share they already possessed, forcing the concrete industry not

---

<sup>165</sup> Podolny, "Economic Comparisons of Stayed Girder Bridges," *Highway Focus*, Vol. 5, No. 2 (Aug 1973), p. 32.

<sup>166</sup> Walter Podolny, Jr., ed. *Highway Focus*, Federal Highway Administration, Office of Engineering, Vol. 5, No. 2 (Aug 1973).

<sup>167</sup> Walter Podolny, Jr. Chrm, ASCE Subcommittee on Cable-Stayed Bridges of the Committee on Metals of the Structural Division, "Data and Bibliography of Cable-Stayed Bridges" (New York: ASCE Press, 1977), p. 2. This text also lists most of the technical and cultural sources on cable-stayed bridges, but does not include many of these kinds of texts on cable-supported structures written almost a decade prior to its publication.

only to compete but expand the use of its own bridge type, the segmental concrete bridge. “Value engineering is another way to economize construction costs,” but the civil engineering practice of “construction management’ of segmental bridges [had] not been applied in this country as far as members of the ASCE’s Long-Span Bridge Committee, knew in 1969.<sup>168</sup> That marketing of cable-stayed bridge construction would become the means to this end goal of value control, value engineers could not have predicted. Industry representatives of the commercial arena to SAVE and VE Study review boards recognized the potential for industry profit from value engineering programs in government construction agencies to transform VE into a means to ends unrelated to the principles of function, cost and worth but derived, nonetheless, from those concepts’ application in real-world not ideal systems building.<sup>169</sup>

“The least that one should, not could, do was create an atmosphere of competition between designs in accordance with prevailing economic conditions,”<sup>170</sup> explained federal officials of the FHWA’s Bridge Office at the 1973 ASCE National Structural Engineering Convention and Exposition, prepping the community for its presence at the FHWA’s Conference on VE the following year. Taking note, editors of *Civil Engineering* magazine advised their readers that competitive design scenarios, such as “cable-stayed bridges versus suspension bridges,” were necessary for projects to acquire federal approval.<sup>171</sup> Their comments were specially geared for the bridges planned to span the Mississippi River, Columbia River and Ohio River—three of the widest U.S. rivers.

---

<sup>168</sup> T.Y. Lin, “Conclusions,” *Prestressed concrete segmental bridges: a compilation of papers presented at Prestressed Concrete Segmental Bridge Construction Seminar*, compiled by Walter Podolny, Jr., Little Rock, Arkansas, October 26-27, 1978, Structural Engineering Series No. 6 (Washington, D.C. : Bridge Division, Office of Engineering, Federal Highway Administration, U.S. Dept. of Transportation : Federal Highway Administration, Office of Engineering, Bridge Division distributor, 1979), p. 206.

<sup>169</sup> “VE—A means to an end?” *SAVE Proceedings—1977*, p. 4

<sup>170</sup> Robert F. Baker, “Engineering Policies, Politics, and Pragmatism,” *Journal of the Transportation Engineering Division*, Vol. 100, No. 1, February 1974, pp. 121-134.

<sup>171</sup> Walter Podolny, Introduction, *Cable-Stayed Bridges*, papers presented at the conference held in Pasco, WA, June 1978, prepared by the Bridge Division, Office of Engineering, (Washington, D.C.: FHWA, 1978), p. 2 (1-6).

Ironically, as a mid-scale project, the 750 ft span of the first vehicular cable-stayed bridge construction in the U.S. falls outside the “main focus of program-wide application of value engineering” with its “strong emphasis on cost control and erection planning” in design of large and major structures’ evaluation phases.<sup>172</sup> It remains unknown whether Leonhardt and Andra Partners joined Arvid Grant’s team to garner the financial incentives for value engineering that came with compliance in these efforts in the process of making the bridge representative of the state-of-the-art of the cable-stayed bridge construction.

Such microeconomics of structural components’ selection gives the cable-stayed bridge type the capacity to move with the market in an indeterminate manner which betrays national boundaries between the U.S. and abroad and the intellectual limits of the Pasco-Kennewick Bridge’s lead designers hailing from those two arenas but the same generation of professional engineers trained in macroeconomics on the one hand (Arvid Grant) and welfare economics on the other (Fritz Leonhardt).<sup>173</sup> Investment in the relatively high initial costs of new composite (steel and concrete) deck technology and incremental launching equipment over the course of the 1970s<sup>174</sup> insures that the economic worth of the cable-stay system of hybrid girder construction that Grant and Leonhardt chose will reduce the entire steel system’s weight to a cost of \$110 per sq ft of superstructure surface ultimately achieved.<sup>175</sup> Combining factory welded steel

---

<sup>172</sup> Peter R. Picard (FHWA), “FHWA Held Conference on Value Engineering,” *Civil Engineering-ASCE*, Vol. 54, No. 3, March 1984, p. 20.

<sup>173</sup> Grant (years alive) was trained as an apprentice pre-WWII, rising ultimately to the status of ASCE Fellow, ACI Fellow and the Washington state Engineer of the Year in 1978 by his “sound, economic decisions” regarding concrete technology, according to the bio on file with the WA Section of the ASCE. Leonhardt was trained professionally under the apprenticeship of Ammann Whitney from 1932-1933 after completing school in Germany. Assigned to the Autobahn in the 1930s and a director of highway reconstruction post-WWII, Leonhardt directed the efficient management of material resources to particular projects through the award of bids to certain fabricators (who also constructed the bridges) and design proposals with an explicit sense of the national economy, as collected from documents in the Anton Tedesko Collections, Dept. of Civil Engineering, Princeton University.

<sup>174</sup> T.Y. Lin, “Conclusions,” p. 206.

<sup>175</sup> Grant, p. 66.

components and factory precast concrete components into one hybrid construction scheme with post-tensioning and prestressing techniques they require for long spans, Grant and Leonhardt leave the cable-system to bear the burden of any sudden changes in the markets for both segmental construction and building systems techniques of assembly and erection from the steel as well as the concrete industries' perspectives.

Ironically, the cable-stay system was not the most available of these technological systems from the U.S. construction industry due to the U.S. war-time use of steel wiring at the time of their report to federal and state officials in 1972.<sup>176</sup> Value engineers' provocative notion that construction schemes built by the "ideal systems technique"<sup>177</sup> slide down the economic scale of market structures into a technological workable system when needed rings true for the Pasco-Kennewick Bridge project. By the end of preliminary studies, Grant and Leonhardt's vision of a cable-stayed system of hybrid construction yields a design for which, on the one hand, the cable-stays must be solicited from German industry due to shortages in American steel cable production these cables uniting the various technologies into a single structural system of actual bridge construction that appears to onlookers to be a uniform-looking "concrete ribbon"<sup>178</sup> across the Columbia River (fig. 2.15).

---

<sup>176</sup> Grant, "Special Features of the Pasco Project," p. 121.

<sup>177</sup> Robert W. Kelley, Experience Curve Analysis of Value Engineering Change Proposals," *SAVE Conference—1966*, p. 128.

<sup>178</sup> Grant, p. Intercity Bridge: A Concrete Ribbon Over the Columbia River, Washington," *Cable-Stayed Bridges, papers presented at the conference held in Pasco, WA, June 1978*, Structural Engineering Series No. 4 (Washington, D.C.: FHWA, 1978), p. 72.

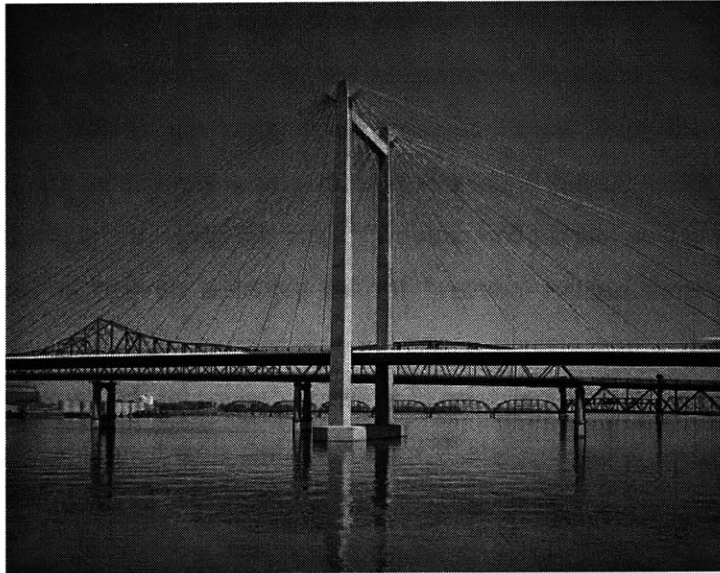

**Figure 2.15. The Pasco-Kennewick Bridges, old and new (NISEE, UC-Berkeley)**

Through the industry contacts of Leonhardt with DWIDAG and DEMAG fabrication/construction companies in Germany, Arvid Grant and Associates, along with other American firms with which Leonhardt and Andra (L&A) consulted in the early 1970s, ultimately “recognize the new types of construction methods and materials, [one of four] seeds of value growth” listed as major objectives of “design-phase value engineering”<sup>179</sup> for the Bridge Replacement Program.<sup>180</sup> Nevertheless, in the case of the Pasco-Kennewick Bridge project, WA-DOH engineers substitute new fabrication techniques for the steel deck Leonhardt’s firm designed, making it ineligible to earn the savings offered by the EPA by the date of the bridge’s construction.<sup>181</sup> Perhaps in its place, the Pasco-Kennewick replacement project provided these two experts in the

---

<sup>179</sup> It is worth noting that “design-phase value engineering” covered all types of design practice preceding construction bid, including conceptual design, bridge type study, creation of alternate designs and detailed design and selection of structural types for those alternate designs. See, Tufty, Tufty, “Controlling Design, Construction, and Maintenance Costs to Combat Inflation,” *Civil Engineering*, October 1981, p. 46.

<sup>180</sup> Bridge Replacement Program,” *Federal Register*, p. 15666 (March 1, 1979), “Preconstruction Procedures of Federal-aid projects, correction, p. 17554, *Federal Register* 26414 (July 19, 1975).

<sup>181</sup> Arvid Grant, Intercity Bridge: A Concrete Ribbon over the Columbia River, Washington,” Cable-Stayed Bridges, *Cable-Stayed Bridges, papers presented at the conference held in Pasco, WA, June 1978*, Structural Engineering Series No. 4 (Washington, D.C.: FHWA, 1978), p. 70.

structural engineering field with a learning experience in the late-capitalist economic “moves” of industries and information. In this spirit of professional versus financial growth, Leonhardt and Grant addressed their American colleagues at the 1978 Conference on Cable-Stayed Bridges as men of a new generation, the former with a “renewed faith in free market competition”<sup>182</sup> and the other an “appreciation for new markets in the construction industry” for his technical services in concrete bridge engineering.<sup>183</sup>

As they intertwined their tales of alternate designs for the Pasco-Kennewick and the East Huntington Bridge projects,<sup>184</sup> it becomes less clear as to which project, which design experience and which commission offered them the lessons in project control and techniques of systems design of construction schemes and value decisions. Unlike U.S. Steel’s fate in the case of the Tagus River Bridge project, however, both AGA and L&A would earn short-term and long-term benefits to their cooperation with value control objectives in the form of cultural recognition for the WA-DOH design ultimately constructed and selected by FHWA officials and a request for an alternate design to the steel girder bridge half-way completed over the Ohio River. For this project, Grant and Leonhardt again collaboratively embark on value engineering study, this time under the FHWA mandate of alternate designs for highway bridge projects that provides both firms with royalties from future cost savings generated by design component changes that result from their ideas versus the objectives for the project.<sup>185</sup> Their selections continued in the case of the East Huntington Bridge to social engineer circumstances that flowed with rather than were structured around industry, as the true value of AGA’s concrete alternate with cable-stay system relative to an orthotropic steel box girder bridge designed by E. Lionel Engineering and constructed partly by American

---

<sup>182</sup> Fritz Leonhardt, “Alternate Design and Engineering Development,” p. 9 (6-10).

<sup>183</sup> Arvid Grant, “Special Features of the Pasco Project,” p. 78 (72-78).

<sup>184</sup> In all three of their papers published as part of *Cable-Stayed Bridges, papers presented at the conference held in Pasco, WA, June 1978*, Structural Engineering Series No. 4 (Washington, D.C.: FHWA, 1978).

<sup>185</sup> E. Lionel Pavlo and Chris S.C. Yiu, “East Huntington Bridge,” pp. 235-236 (234-247).

Bridge Engineering would not be proven until an audit of construction bids in 1979. From 1974, when the alternate design was proposed, until then, the potential for these savings from high-strength steel construction instead justifies the designs' contributions to the bridge's status as an official FHWA "demonstration project" for high-strength concrete decks' feasibility for future major highway and roadway projects.

There were objections from American civil engineers to such federal interventions and peer review that value engineering policy-makers claimed savings required. *Civil Engineering* magazine editors emphasized that since the design engineer "alone takes on the responsibilities for proper design,"<sup>186</sup> as evidenced in fault and fines falling to E. Lionel Pavlo Engineering, Inc. when the West Virginia DOH sued contractors for a failed approach span to the East Huntington Bridge, the burden of safety should fall on the consultant engineers of alternate designs. Associated with the contemporary 'command centers' of NORAD and SAGE, to name a few, federal design review boards assembled to ensure codes of civil engineering practice regarding value engineering and alternate design studies kept pace in state highway divisions inspired the traditionally less vocal consulting structural engineers in a culture of anti-militarism that dates back to American civil engineers' split in 1857 from military employment and militaristic practice of structural and environmental engineering.<sup>187</sup> Since the requisite divergent behavior for structural engineer-led VE Studies alluded to undesirable German and Belgian models of peer review and "authoritarian command," neither defining designs in law nor licensing particular engineers to guarantee a design's compliance with the most current disciplinary standards would result in the "friendly assistance" to the consulting engineer<sup>188</sup> that some claimed was their right as consultants to the states not "state engineers."<sup>189</sup>

---

<sup>186</sup> John P. Gnaedinger, "Peer Review: Old Concept in New Situations," *Civil Engineering-ASCE*, Vol. 48, No. 2, February 1978, pp. 45-47.

<sup>187</sup> *Ibid.*

<sup>188</sup> *Ibid.*

<sup>189</sup> Fritz Leonhardt, "Alternate Design and Engineering Development," p. 9.

The revised Environmental Protection Act of 1974, which required socioeconomic assessment of all projects' preliminary plans estimated at over \$1 million, would force the hand of FHWA to politicize the practice of designing alternate designs for economic evaluation through design-phase programs if not bidding procedures for contractors.<sup>190</sup> The state of California's Bridge Authority had recorded 300 value engineering considerations for projects already begun and initiated from 1970 to 1978, of which 200 VE schemes were adopted for a total savings of \$2 million.<sup>191</sup> The hunch that "non-deterministic decision-making" was becoming a norm in highway planning is confirmed by the FHWA's policy statement on "Alternate Designs for Bridges"<sup>192</sup> but also the bullet lists of procedures and description of the program's history outlining procedures for under what kind of "prevailing market conditions"<sup>193</sup> value engineering proposals would change the geometry of original designs. The subversive potential of "alternate designs for bridges"—both the policy and the cultural production—to remain under the radar until it became an official policy item for the Federal Highway Administration's docket in 1974 surely is owed to the due diligence of structural engineers concerned with quality assurance and authority as value analysis of bridge selections becomes value engineering of bridges. Radically re-conceiving consulting structural engineer's professional practice of conceptual design as a social scientific service, these engineers' cooperation in project control proves more effective than policy in circumventing issues of militarism and more efficient than complex networks of collaboration for ultimately inscribing the value of technological development in structural systems by innovations in socioeconomic systems building.

In the rise of bridge engineers to the stature of highway engineers with their increased federal budget for replacement, revision, and renewal of bridges in the 1980s,

---

<sup>190</sup> "New highway environmental guidelines give public more say," *ENR* (July 6, 1972), p. 10.

"Train Says EPA needs more time and money," *ENR*, (October 16, 1975), p. 12.

<sup>191</sup> T.Y. Lin, "Conclusions," p. 172.

<sup>192</sup> "Alternate Designs for Bridge: Policy Statement," *Federal Register*, vol. 48, no. 93, Thursday, May 12, 1983, p. 21409.

<sup>193</sup> *Ibid.*



reconfiguring construction schemes for the cable-stayed Pasco-Kennewick and East Huntington bridges to meet present and future economic objectives with these technologies won Arvid Grant and Associates the awards for design, innovation and beauty that the National Endowment for the Arts began issuing to federally-funded civil architecture in 1985. The introductory arguments for post-modern engineering and opening remarks on cable-stayed bridges' meaning in preliminary alternate designs remain absent from the Historic American Engineering Record, however. The work of this new generation of civil engineers epitomizes the master plan of a new record, that of Design Excellence in Federal Design, which awards civil engineers that consult on but also cooperate with the administrators of economical bridges of functional and aesthetic value to the federal government and its community values.

Without further study of the American and foreign civil engineering organizations involved in the "VE effort," it is difficult to determine for just how long and to what extent the major cable-stayed bridge projects of this period in fact started a movement of post-industrial design and engineering sensibilities beyond this phase of systems building in American civil engineering culture. Known however, is that for these projects, the cultural logic of VE schemes that increase and extend to "postmodern engineering"<sup>194</sup> of high-rise corporate architecture and bridge project charrettes of the 1980s are one and the same: post-capitalist theories of relativism and pluralism for adapting social and technical semantics to systems of building. The industrial engineering methods of systems building employed by these renown structural engineers to conceptually design and analytically construct structural systems for the Pasco-Kennewick suggest that meeting the goals of value control in conceptual and design phases of bridge projects lays the path for deterministic principles of structural

---

<sup>194</sup> David A. Platten (Asst., The Datum-Moore Partnership, Dallas), "Postmodern Engineering," *Civil Engineering-ASCE*, Vol. 56, No. 6, June 1986, p. 84-86. This article specifically discusses such VE schemes for Momentum Place, declared a "postmodern skyscraper" (84) because it is a tower that changes shape 4x between street level and a cross-vaulted arch at the 60<sup>th</sup> floor roof; designed by architects John Burgee and Philip Johnson, the Partnership of structural engineers, "designed the structural system with extensive" value engineering" (84)—35 schemes.

engineering economics to yield to a value system of imaginative engineering that was sought for themselves from the start.

## Conclusion

Value engineering theory that developed over the twenty years prior to VE policies of alternate design for bridges was not enough to define for the principled structural engineering community the value control that federal officials encouraged of all construction systems, including public architecture. Becoming conduits of interdisciplinary design in this discourse between the various incarnations of VE—value analysis, engineering and management, FHWA officials could not merely ask for bridge engineers and state highway administrators to make the rational choice of an economical bridge type and ask questions later. Nevertheless, structural engineers' analytical studies of bridge spans and building structures designed with independent support systems and a matrix of components to develop under the uncertain conditions of steel and concrete industries provide the "Rx for VE thought"<sup>195</sup> that was barely holding together the tabular, surprise and fuzzy decision logic of cost-value decisions about economics, aesthetics and the heuristic design processes of systems building.<sup>196</sup> Without their analytical studies of alternate girder bridges and segmental bridge construction schemes, the various social and technical studies of cost defining VE in 1969 would have struggled to sustain political support that the "VE effort" required. Perhaps, even the so-called "renaissance" of American bridge engineering through value engineering that develops alongside this political discourse in the 1970s would have been delayed into the 1980s when environmental planners and landscape architects pick up VE to reinvigorate their discipline's theory of selecting designs in fitness with social conditions as well as the environment.<sup>197</sup>

---

<sup>195</sup> Roger A. Lockwood, "Interdisciplinaryism: Rx for VE," SAVE Conference—1968 (Chicago: Robert J. Mayer & Co., 1968), p. 137-143.

<sup>196</sup> Fenves, S. J., "Tabular Decision Logic for Structural Design," *Journal of the Structural Division*, ASCE, Vol. 92, No. ST6, pp. 473-490 (p. 475).

<sup>197</sup> See, Kirk Stephens, "Integrating Value Engineering into the Design Process," *Ekistics*, Vol. 56, No. 336-337, (May-Aug 1989), pp. 166-170; Thomas R. Chamberlain, "Value Engineering, function and FAST in building design," *Ekistics*, Vol. 56, No. 336-337, (May-Aug 1989), pp. 198-201; Bob Groot, "Value Engineering: its applications to landscape architecture," *Landscape Architectural Review*, Vol. 7, No. 4 (Sept 1986), pp. 21-24.

Engineering value into the multifaceted infrastructure system was the plan all along for these engineers, but their socioeconomic impact assessment of bridge types merely prompted the creation of alternative—not alternate—designs, most of which failed to meet expectations of social and economic evaluation.<sup>198</sup> As elegant and technologically advanced cable-stayed bridge designs became as a result of heading impact assessment guidelines, the bridges’ artistic visual expression and technical soundness did not turn the tide of ‘freeway revolts’ stonewalling the replacement of older vehicular bridges. Like the Seattle city council, which approved and then rescinded financing for two cable-stayed highway bridges in 1972, Robert Moses would also have to abandon his plans to add a cable-stayed bridge to the NYC bridgescape and “to continue the tradition of modern architecture in the 1970s”<sup>199</sup> through other means besides extending the Long Island Expressway with this bridge form. Urban design of these alternative designs for existing highway bridge alignments created productivity in the area of architectural and conceptual design for bridges but not profit despite the ethos of interdisciplinary design and teamwork<sup>200</sup> these practices shared with value engineering.

The “appearance design”<sup>201</sup> of functional construction systems that Lawrence Miles proposed would achieve political or commercial objectives of value analysis and

---

<sup>198</sup> EPA’s “Program Guidance Memorandum No. 63” (January 20, 1976). Also see, Harold Tufty, “Value Engineering Made Mandatory on EPA Projects Over \$10,000,000,” *Civil Engineering-ASCE*, Vol. 46, No. 9, September 1976, pp. 101-103.

<sup>199</sup> “Moses Approves New Bridge,” *Engineering News Record* (1971).

<sup>200</sup> Alternative bridge alignments became a solution the transportation community generally agreed had worked in the earlier half of the 1960s. *Transportation and Community Values*, Special Report 105 (Washington, D.C.: Highway Research Board, National Research Council, 1969), p. 3.

<sup>201</sup> Ironically, structural engineers Eduardo Torroja and Buckminster Fuller had only given lectures on cable-stayed roofs and open structures resembling sculpture to art and architectural schools; in the architectural discourse on space structures and environmental form, cable-stayed bridges had not yet emerged as an object of “play,” as David Billington put it. See, David Billington and Robert Mark, *Civil Engineering in the Urban Environment*, text from the course held at Princeton University, 1967, Loeb Library, MIT. Not coincidentally, in *Techniques of Value Analysis and Engineering*, Lawrence Miles also refers to aesthetic design of construction systems (including bridges) as “appearance design.” Used to design “features” of a construction which

engineering makes little impact in the frame of these ten years of the VE effort in civil engineering culture traced by planning, design and construction phase control of actual bridge projects as well as cultural and analytical bridges between the cultural discourse of value control begun by Miles. Cable-stayed bridges sketched in three-dimensions by artists for public reviews,, such as the Southern Crossing of the San Francisco Bay suffered the same fate as more technical expertise in aerodynamics. Of course many civil engineers continued to claim that standardization not “the questionable technique of systems building” would speed the time of public approval by which project selections accrue additional costs unrelated to construction per se,<sup>202</sup> but a new type of selecting the bridges to apply standardized components offered more flexibility of application with innovative engineering concepts.

Value Engineering in Preconstruction Activities provided the systematic approach to radically revise the determinate decisions as well as the fixed master plan for urban topography chronicled in the “greatest decade”<sup>203</sup> of interstate highway building. Opening the door for both aesthetic bridge design, the concern those structural engineers who organized the first National Conferences on Civil Engineering History at Princeton University in the 1970s, , and federalism, a focus of congresses on civil engineering history and heritage begun by the ASCE History and Heritage Committee in 1996,<sup>204</sup> alternate designs have under other names emerged in the cultural histories of bridges in both “liberal studies of civil engineering” and architectural studies. Perhaps, further such studies of structural engineers’ position in American history will reveal the human effects of value engineering in civil engineering culture

---

make the consumer want to buy a product, this design method is not dissimilar to the meaning architecture would take on as a medium of economic speculation upon building technology, p. 229.

<sup>202</sup> *Aesthetic Concrete Bridge Design*, (Pittsburgh, PA: ACI, 1990).

<sup>203</sup> “The Greatest Decade,” Interstate Highway History Series, [www.fhwa.dot.gov/interstate](http://www.fhwa.dot.gov/interstate).

<sup>204</sup> See *Civil Engineering History: engineers make history, proceedings of the First National Symposium on Civil Engineering History*, ed. Jerry R. Rogers, sponsored by the ASCE, the ASCE National Capitol Section and the U.S. Capitol Historical Society in conjunction with the ASCE National Convention in D.C., Nov. 10-14, 1966; (New York: ASCE, 1996).

that extend beyond bridge design to the practice of conceptual design ultimately tied up in these developments.

Perhaps in these qualitative types of bridge evaluations, the cultural history of value engineering and alternate designs can become more robust and on par with the theoretical studies of cybernetics and systems theory in value engineering.. Ultimately, federal officials solicited from structural engineers more detailed prescriptions for valuable bridges in the form of alternate designs mandatory under FHWA law for construction bidding. This shift from acculturating professional engineers in value engineering and controlling professional engineering practice developed only as the energy crisis added further pressure for even more different types of construction systems than those already commissioned by the General Services Administration (GSA), the Environmental Protection Agency (EPA) for potential savings . Other less visible changes in civil and structural engineering culture may have also developed but without the visibility of cable-stayed bridge constructions to show for it.

Though not in this short period of a decade, bridge engineers would acquire from “VE study” parameters for design decisions, which include cost, function and worth throughout the facility’s life, and formulate their own theory of functionality for design selections that fall within those boundaries as RAND Corporation studies of nuclear facilities had done with EPA plant selection guidelines.<sup>205</sup> For instance, after week-long training in value engineering, architects and structural engineers concluded that savings could be obtained by designers “modify[ing] the construction methods and materials currently used...combining or consolidating sections [and] eliminating unnecessary superstructure area.”<sup>206</sup> Value engineers’ systems design of functionality—

---

<sup>205</sup> “Value Engineering Applications to the Design of Nuclear Power Facilities,” RAND Corporation, 1966, Harvard University, Cambridge, MA.

<sup>206</sup> EPA’s “Program Guidance Memorandum No. 63” (January 20, 1976). Also see, GAO report to the U.S. Congress, “Potential of Value Analysis for Reducing Waste Treatment Plant Costs” (May 8, 1975). Notably, an independent design firm commenting on the proposals that resulted from the EPA/AIA/ACEC/GSA study noted that the AIA/ACEC proposals generally fell into 3 categories: 1) “some could have been implemented had they been proposed during the design phase,” 2)

rather than modularity, or constructability, or any other design concept borrowed from construction systems design—made such reductionism seem “innovative” apparently to professionals besides officials of the Federal Highway Administration (FHWA) and GSA officials, who on the eve of post-modernism in both architectural and structural engineering culture, announced that alternate designs for bridges and federal buildings would become law.<sup>207</sup> Much of the value engineering provisions of this policy have been dropped since 1983, but the comparative framework of alternate designs to be evaluated by market conditions and reconfigured into construction schemes from structural systems remains in bridge project development today.

The preliminary designs and multiple construction schemes that define these non-deterministic decisions of state highway officials create a subjective set of data incongruent with the quantitative proof strived for in most historical studies of bridge structures and constructions, even when the history of technology is not the focus. The industrial economics and operations research from which Lawrence Miles first derived value analysis and engineering offers a broader scheme for research of bridges, that could expand not only the geographic and historical scope of research but also offer a means to connect these central to civil engineering history to another generation of research that focuses on the later post-WWII period in which the economic framework of social theory has shifted to a slippery slope between cultural studies of bridge *projects* and social studies of design evident in this thesis. Opportunities to further this exploration of both these methods and this period exist since American value engineers’ take on market economics began in the Keynesian economics of free market competition and welfare economics, which infused the “postwar institutions” of

---

“some proposals were technically feasible, but, because of regulatory agency requirements and engineering judgment, they probably would not have been implemented,” 3) “some proposed changes were not practical because of technical considerations.” Tufty, p. 103.

<sup>207</sup> “Alternate Designs for Bridges: Technical Advisory,” *Federal Register*, Vol. 47, No. 201 (Monday, October, 18, 1982), p. 1979.

reconstruction in Central Europe and West Germany,<sup>208</sup> namely “competitive design bidding” popular in the analysis of cable-stayed bridges by Billington. In fact, value engineering thought as well as policy yielded the seeds of partnership between engineers and contractors’ design-build teams, which the editor of *Civil Engineering* magazine recognized in 1983 to have significantly changed the social relations and professional landscape of American bridge engineering culture. With construction engineering leaders of Europe, such as F. Finsterwalder, Jean Mueller and Fritz Leonhardt, increasingly offering their expertise to civil engineers engaged in preliminary and feasibility studies of alternate designs from 1969 to 1979, the designs they proposed and major bridge projects they studied offer a place to continue critically examining this historical phenomena of American civil engineers’ evaluation and selection of cable-stayed bridges through the 1980s and into today.

For such studies, cultural history needs to be further developed as a methodology for critically examining the knowledge, values and circumstances under which bridges develop. At the base of Haw’s visual studies *The Brooklyn Bridge: A Cultural History* and the cultural theory of technology in David Lynch’s the *Technological Sublime*, perspectives from American, urban and environmental studies on the one hand offer a interdisciplinary and area studies an approach that perhaps balances the duality of science and technology studies on the other. The philosophy of structures that made

---

<sup>208</sup> James C. Van Cook, *Rebuilding Germany: the creation of the social market economy, 1945-1957* (New York: Cambridge University Press, 2004), p. 43. Guided by state control of heavy industry for steel and the financing structures behind it, namely the steel industry and the Autobahn Authority, a decentralization of planning was built by American industrial engineers to cooperate with West Germany’s new social versus free market economy. KRUPP one of the largest fabricators of bridges for military use prior to the war and civil bridges afterwards, was taken over by the Army Corps of Engineers and required to participate in this system of decentralization and decartelization called alternate design and competitive design interchangeably. It has the same economic structure as the competitive design competitions, according to James B. Kooke, Major, Corps of Engineers, European Theater of Operations, “German War Bridge Has Proved Useful to Allied Forces,” *Civil Engineering*, November 1945, Vol. 15, No. 11., p. 513. And Waldo G. Bowman, ed. *Engineering News Record*, (October, 39, 1947), p.54-67.



Billington's studies of Robert Maillart's concrete engineering of structural form has changed partly as a result of structural engineers proudly developing "35 value engineering schemes"<sup>209</sup> for Phillip Johnson's AT&T Building design, for instance, amongst other developments in structural engineering culture and practice labeled "postmodern engineering."<sup>210</sup> Where these technical traditions of engineering history fit in, along or tangential to the trajectory set by Robert Mark and the earlier works of David Billington remains a question that is necessary for determining to what scholarly field of research cultural studies of a qualitative nature that extend or expand this thesis to architectural and planning constructions will contribute.

For architectural historians, interdisciplinary contributions to architecture and engineering from 1945 to 2006 will emerge at the 2007 Conference of the Society of Architectural Historians as the historical frame for investigating these questions, suggesting this problem statement already has value but few answers:

"An intriguing subject for study is also the issue of how we are to describe the significance of interdisciplinary and engineering culture for architecture. Are we to provide an account of "author figures" based on attribution? Or are there other forms of exploration that emphasize network and context rather than the link between author and work?"<sup>211</sup> (2007 Call for Papers)

As a first step into the scholarly field of architectural studies, this thesis takes the charge of exploring network and contexts of value engineering on the one hand, and the contributions of preliminary designs' authors and constructed works in the purview of both. The disjunction between interdisciplinary contributions from architecture to engineering and vice-versa deserves further study. The social scientific methods of science and technology studies may need to play the role of interlocutor, unlocking theories of technology from the black box of engineering culture and dispersing it into

---

<sup>209</sup> David A. Platten (Asst., The Datum-Moore Partnership, Dallas), "Postmodern Engineering," *Civil Engineering-ASCE*, Vol. 56, No. 6, June 1986, p. 84 (84-86).

<sup>210</sup> Ibid.

<sup>211</sup> 2007 Call for Papers, Chairman Deitrich Neumann, Brown University, 61st Annual Meeting of the Society of Architectural Historians, April, 23-27, 2008, Cincinnati, OH (<http://www.sah.org>)

the discourses of science and art with which architecture exchanges metaphors but also media and philosophies of structures through civil and structural engineers.

## Bibliography

### *Primary Sources*

American Concrete Institute, *Aesthetic Concrete Bridge Design* (Pittsburgh, PA: ACI, 1990).

American Management Association, *Report on Value Engineering*, proceedings from the 1970 Convention of the AMA, 1970.

Airlie Conference Center, [www.airlie.com](http://www.airlie.com)

Altshuler, A., "The Values of Urban Transportation Policy," Conference on Transportation and Community Values, *HRB Special Report 105* (1969), 75-86.

"Big Steel Spike: the U.S. Steel Building is a Symbol of both an Industry and a city," *Architectural Forum*, vol. 135, no. 5, (Dec 1971), 24-29.

Baron, F. and Lien, S.Y., "Analytical Studies of a Cable-Stayed Girder Bridge," *Computers & Structures*, Vol. 3, (New York: Pergamon Press, 1973), 443-465.

Baron, F. and Lien, S.Y. "Analytical Studies of the Sothern Crossing Cable-Stayed Girder Bridge," Report No. UC SESM 71-10, Vols. I and II, Dept. of Civil Engineering, UC-Berkeley, California (1971).

Building Research Advisory Board, Federal Construction Council, *Value Engineering in the Federal Construction Agencies*, Symposium-Workshop Report Number 4, May 27, 1969 (National Academy of Sciences, 1969).

Billington, D. and Nazmy, A., "Aesthetics of Cable-Stayed Bridge Design," *Journal of Structural Engineering*, Vol. 117, No. 10, (October, 1990), 3103-3134.

David Billington and Robert Mack, "Civil Structures in the Urban Environment" (Princeton, NJ: Princeton University Department of Civil Engineering, 1967).

Bloomfield, P., Westerling, D. and Carey, R., "Innovation and Risk in a Public-Private Partnership: Financing and Construction of a Capital Project in Massachusetts," *Public Productivity & Management Review*, Vol. 21, No. 4, (Jun., 1998), 460-471.

Bolce, J.R., A History and Evaluation of SCSD (Building Systems Information Clearing House, Educational Facilities Lab, Ford Foundation). Loeb Library, Harvard Graduate School of Design.

Bridges, C. P., "Erection Control: Pasco-Kennewick Intercity Bridge," *Cable-Stayed Bridges, papers presented at the conference held in Pasco, WA, Dec. 1978* (Washington, D.C: FHWA, 1978), 133-145.

Bynum, S.D. "Construction Management and Design-Build/Fast Track Construction from the Perspective of a General Contractor," *Law and Contemporary Problems*, Vol. 46, No. 1, (Winter, 1983), pp. 25-38,

Bytheway, C.W., "Function Definition and FAST Diagram Construction," *Workshop IV: Function and FAST, SAVE Conference—1977, Proceedings of the 1977 International Conference*, Vol. 11, 220-222.

Chamberlain, T.R., "Value Engineering, function and FAST in building design," *Ekistics*, Vol. 56, No. 336-337, (May-Aug 1989), 198-201.

Churchman, C.W., Ackoff, R., and Arnoff, E.L. *Introduction to Operations Research* (New York: John Wiley and Sons, 1957).

Clint, P., "Question: What is Value Engineering of...," *AIA Journal*, Vol. 62, No. 1 (July 1974), 41-43.

Cook, T.F., "Value Engineering and the Third Revolution," National Conference of the Society of American Value Engineers held in Chicago, Illinois, May 13-16, 1973, *SAVE Proceedings*, vol. VI, 15-21.

*Department of Transportation Act of 1967* (Washington, D.C.: U.S. Government Printing Office, 1967).

Franz Dischinger, "Hangebrucken fur schwerste Verkehrslasten [part a]," *Der Bauingenier*, (Berlin, Germany), 24(3), 65-75.

Franz Dischinger, "Hangebrucken fur schwerste Verkehrslasten [part b]," *Der Bauingenier*, (Berlin, Germany), 24(3), 107-113

Environmental Protection Agency, "Program Guidance Memorandum No. 63" (January 20, 1976).

Elliot, P. "Can Steel Bridges Become More Competitive," *Proceedings of the Conference on Steel Bridges* (London: The British Steelworkers Association, Ltd, 1968).

Falcon, W., ed., *Value Analysis, Value Engineering and the implications for managers*, (New York: AMA, 1964), AMA Management Report No. 81, p. 34.

Fallon, C., "Body of Knowledge Underlying the Value Disciplines," *SAVE Conference--1971* (Washington, D.C.: Spartan Books, 1971), vol. VI, 22-29.

Baker, R.F., "Engineering Policies, Politics, and Pragmatism," *Journal of the Transportation Engineering Division*, Vol. 100, No. 1, February 1974, 121-134.

"Train Says EPA needs more time and money," *ENR*, (October 16, 1975), 12.

Federal Highway Administration, "Preconstruction Procedures of Federal-aid projects, correction, p. 17554, *Federal Register* (July 19, 1975), 26414.

Federal Highway Administration, "Bridge Replacement Program," *Federal Register*, Vol. 47, No. 201 (Monday, Oct. 18, 1982), 46403.

Federal Highway Administration, "Alternate Design for Bridges: Policy Statement," *Federal Register*, Vol. 48, No. 93 (Thursday, May 12, 1983), 21409

Federal Highway Administration, *VE for Highways* (Handbook), 1<sup>st</sup> ed., (Washington, D.C.: FHWA, 1970).

Fenves, S. J., "Tabular Decision Logic for Structural Design," *Journal of the Structural Division*, ASCE, Vol. 92, No. ST6, 473-490.

General Services Administration, "Potential of Value Analysis for Reducing Waste Treatment Plant Costs" (May 8, 1975).

Gnaedinger, J.P., "Peer Review: Old Concept in New Situations," *Civil Engineering-ASCE*, Vol. 48, No. 2, February 1978, pp. 45-47.

Godfrey, G.B., "Postwar Developments in Germany Steel Bridges and Structures," *Structural Engineer*, Vol. 35, No. 10 (October 1957), 390-398.

Grant, A., "Intercity Bridge: A Concrete Ribbon Over the Columbia River, Washington," *Cable-Stayed Bridges, papers presented at the conference held in Pasco, WA, June 1978*, Structural Engineering Series No. 4 (Washington, D.C.: FHWA, 1978), 57-71.

Grant, A., "Pasco-Kennewick Bridge—the longest cable-stayed bridge in North America," *Civil Engineering—ASCE*, Vol. 47, No. 8 (August 1977), 62-66.

Grant, A., "Special Features of the Pasco Project," *Cable-Stayed Bridges, papers presented at the conference held in Pasco, WA, 1978*, Structural Engineering Series No. 4 (Washington, D.C.: FHWA Bridge Division, June 1978), 72-28.

Gouze, G.M., "Value Engineering and Creativity: A Double Self Generating Tool of Management," *Proceedings of the SAVE Conference-1971*, p. 2.

Groot, B., "Value Engineering: its applications to landscape architecture," *Landscape Architectural Review*, Vol. 7, No. 4 (Sept 1986), 21-24.

Gute, W.L., "First Vehicular cable-stayed bridge in the U.S.," *Civil Engineering—ASCE*, Nov. 1973, Vol. (Nov. 1973), p. 54.

Harvey, Jr., A., "What makes Value Engineers?" National Conference of the Society of American Value Engineers held in, May 24-26, 1971, *SAVE Proceedings*, Vol. 6, 26-36.

Hedefine, A. and Silano, L.G., "Design of the Fremont Bridge," *ASCE National Structural Engineering Meeting*, Preprint Paper No. 1210.

"Highlights of the ASCE National Structural Engineering Convention and Exposition," *Civil Engineering—ASCE*, Vol. No. (June 1975), 80 -81.

Jarosz, E. S., "Design of the Luling Bridge," *ASCE National Structural Engineering Meeting*, Baltimore, MD, April, 19-13, 1971.

Jarosz, E. S., "Luling Bridge," *Cable-Stayed Bridges*, Structural Engineering Series No. 4 Bridge Division (Washington, D.C.: Federal Highway Administration, June 1978), 219-233.

Kavanaugh, T.C., "Discussion to 'Historical Developments of Cable-Stayed Bridges' by Walter Podolny and John Fleming," *Journal of the Structural Division*, ASCE, Vol. 99, No. ST7, July 1973, Proc. Paper 9826, 1669.

Kealy, R.T., *Feasibility Study of Mississippi River Crossings Interstate 410*," Meeting Preprint, 2003, *ASCE National Structural Engineering Meeting*, April 9-13, 1973, San Francisco, California.

Kelley, R.W., "Experience Curve Analysis of Value Engineering Change Proposals," *SAVE Conference—1966*, 128-131.

Kooke, J.B. (Major, Corps of Engineers, European Theater of Operations), "German War Bridge Has Proved Useful to Allied Forces," *Civil Engineering*, November 1945, Vol. 15, No. 11, 511-515.

Kingscott, Jr., L.C., "The Construction Industry and Value Engineering," *SAVE Conference-1969*, Vol. 3, 81-83.

Lockwood, R. A., "Interdisciplinaryism: Rx for VE," *SAVE Conference—1968* (Chicago: Robert J. Mayer & Co., 1968), 137-143.

Louisiana Division of Engineers, *Preconstruction Pages, A Publication of the LADOTD Preconstruction Project Development Division*

Leonhardt, F. and Zellner, W., "Cable-Stayed Bridges: Report on Latest Developments," *Proceedings of the Canadian Structural Engineering Conference, 1970*, Canadian Steel Industries Construction Council, Toronto, Ontario, Canada.

Leonhardt, F., "Alternate Design and Engineering Development," *Cable-Stayed Bridges, Cable-Stayed Bridges, papers presented at the conference held in Pasco, WA, June 1978*, Structural Engineering Series No. 4 (Washington, D.C.: FHWA, 1978), 6-10.

Leonhardt, F., "Future of Cable-Stayed Bridges," *Cable-Stayed Bridges, Structural Engineering Series, No. 4* (Washington, D.C.: FHWA, June 1978), 304-318.

Leonhardt, F. and Zellner, W., "Cable-Stayed Bridges," *IABSE Periodica 2/1980-IABSE Surveys S-13/80* (May 1980).

Lin, T.Y., "Conclusions," ed. *Prestressed concrete segmental bridges : a compilation of papers presented at Prestressed Concrete Segmental Bridge Construction Seminar, Little Rock, Arkansas, October 26-27, 1978 / sponsored by Region 4 of the Federal Highway Administration, ; compiled by Walter Podolny, Jr, Structural Engineering Series No. 6* (Washington, D.C. : Bridge Division, Office of Engineering, Federal Highway Administration, U.S. Dept. of Transportation : Federal Highway Administration, Office of Engineering, Bridge Division distributor, 1979).

Milton F. Lunch's "New Construction Methods and New Roles for Engineers," *Law and Contemporary Problems*, Vol. 46, No. 1, (Winter, 1983), 83-94.

Lockwood, Roger A., "Interdisciplinaryism: Rx for V.E.," *SAVE Conference—1968* (Chicago: Robert J. Mayer & Co., 1968), 137-143.

Love, S.F., "A New Approach to Value Engineering from Cultural Anthropology," Doctor of Design Candidate, University of Waterloo, *SAVE Conference—1969*, Washington, D.C., Vol. 3, 108-114.

Modjeski and Masters, Consulting Engineers, "Feasibility Study of Mississippi River Crossings Interstate Route 410," a report to Louisiana Department of Highways with Cooperation with Federal Highway Administration, Harrisburg, Pennsylvania, July 1971.

Neumann, D., Chrm., "2007 Call for Papers," 61st Annual Meeting of the Society of Architectural Historians, April, 23-27, 2008, Cincinnati, OH, [www.sah.org](http://www.sah.org).

Oglesby, C. and Grant, E.L., "Economic Analysis—the Fundamental Approach to Decision in Highway Planning and Design," *TRB, Proc.* 37 (1958), 45-57.

New York Bridge Authority archives:

[http://www.nysba.state.ny.us/bridgepages/NBB/NBBpage/history/nbb\\_history4.htm](http://www.nysba.state.ny.us/bridgepages/NBB/NBBpage/history/nbb_history4.htm).

Picard, P.R. (FHWA), "FHWA Held Conference on Value Engineering," *Civil Engineering-ASCE*, Vol. 54, No. 3, March 1984, p. 20.

Platten, D.A. (Asst., The Datum-Moore Partnership, Dallas), "Postmodern Engineering," *Civil Engineering-ASCE*, Vol. 56, No. 6, June 1986, 84-86.

Princeton University Dept. of Civil Engineering's Anton Tedesko Collections.

Pavlo, E. L. and Yiu, C.S.C., "East Huntington Bridge," *Cable-Stayed Bridges, Cable-Stayed Bridges, papers presented at the conference held in Pasco, WA, June 1978*, Structural Engineering Series No. 4 (Washington, D.C.: FHWA, 1978), 234-247.

Podolny, Jr., W., "Cable-Stayed Bridges," presented at the AISC National Engineering Conference, Philadelphia, PA in May 1973, *Engineering Journal* (First Quarter, 1974).

Podolny, Jr., W., "Economic Evaluation of Girder Bridges," *Highway Focus*, ed. Walter Podolny (FHWA: Office of Governmental Printing, May 1973).

Podolny, Jr., W. and Fleming, J., "Historical Development of Cable-Stayed Bridges," *Journal of the Structural Division*, ASCE, Vol. 98, No. ST9 (September 1972), Proc. Paper 9201, 2079-2095.

Podolny, Jr., W., Chrm, ASCE Subcommittee on Cable-Stayed Bridges of the Committee on Metals of the Structural Division, "Data and Bibliography of Cable-Stayed Bridges" (New York: ASCE Press, 1977).



Podolny, Jr., W., ed., "Cable-Stayed Bridges: A Current Review," O.H. Ammann Centennial Conference on Long-Span Bridges, *Annals of the NY Academy of Science*, Vol. 2, No. 9 (August, 1981).

Rogers, J.R., ed. *Civil Engineering History: engineers make history, proceedings of the First National Symposium on Civil Engineering History*, sponsored by the ASCE, the ASCE National Capitol Section and the U.S. Capitol Historical Society in conjunction with the ASCE National Convention in D.C., Nov. 10-14, 1966; (New York: ASCE, 1996).

*Proceedings from the Public hearings on the application of value engineering of the U.S. Senate Committee on Public Works and the Environment* (Washington, D.C.: U.S. Government Documents Office, 1967).

Sanchez, R., "Modular architectures in the Marketing Process," *Journal of Marketing, Fundamental Issues and Directions in Marketing*, Vol. 63, 5-23.

Stajich, M.A., Value Engineering Through Creative Thinking, *SAVE Conference—1971*, Vol. 5, 9-14.

Stephens, K., "Integrating Value Engineering into the Design Process," *Ekistics*, Vol. 56, No. 336-337, (May-Aug 1989), 166-170.

Taylor, P.R., Cable-Stayed Bridges and Their Potential in Candada," *The Engineering Journal* (Canada), Vol. 52, No. 11 (Nov. 1969, 15-27.

Thul, H., "Cable-Stayed Bridges in Germany," *Proceedings of the Conference on Structural Steework held at the Institution of Civil Engineers*, September, 26-29, 1966. (London: The British Constructional Steelwork Association, Ltd (1967), 69-81.

Tufty, H., "Controlling Design, Construction, and Maintenance Costs to Combat Inflation," *Civil Engineering* (October 1981), 46.

Tufty, H., "Value Engineering Now Included by EPA in Construction Grant Program," *Professional Engineer* (Washington, D.C.: Vol. 45, No. 6 (June 1975), 36-38.

Tufty, Hal, Value Engineering Now Included by EPA in Construction Grant Programs, *Professional Engineer* (Washington, D.C.), v 45, n 6, Jun, 1975, p 36-38

*Transportation and Community Values*, report on the conference held at Arlie House, 1969 (Washington, D.C.: Highway Research Board, National Research Council, 1969).

Tang, A., "Decision-Making under Uncertain Conditions," ASCE National Structural Engineering Meeting, Baltimore, April 19-23, 1971.

Tang, A., "Decision Processes and Computer Methodology," ASCE National Structural Engineering Meeting, Baltimore, MD, April, 19-13, 1971.

Van Cook, J.C. *Rebuilding Germany: the creation of the social market economy, 1945-1957* (New York: Cambridge University Press, 2004).

### *Secondary Sources*

Benjamin, J.R. and Cornell, C.A, eds. *Probability, Statistics and Decision for Civil Engineers*, (New York: McGraw-Hill, 1970).

Brown, K.A. *Diversity by Design: Howard Needles Tammen Bergendorff* (New York: HNTB, 1989), 116-17.

Cravens, H., ed. *The Social Sciences go to Washington: The Politics of Knowledge in the Postmodern Age* (New Brunswick, NJ: Rutgers University Press, 2004).

Dell'Isola, A. *Value Engineering in Construction Industry* (New York: Construction Publication Co., 1974)

Dreicer, G.K. "The Long Span. Intercultural Exchange in Building Technology Development and Industrialization of the Framed Beam in Western Europe and the United States, 1820-1870" (Ph.D Dissertation, Cornell University, 1993).

Fleischer, G.A., ed. *Nondeterministic Decision-making in Engineering Economy*, Engineering Economy Division Monograph Series No. 2 (Norcross, GA: American Institute of Industrial Engineers, Inc., 1975).

Galison, P. "The War on Space," *Architecture and the Sciences Exchanging Metaphors*, eds. Antoine Picon and Alessandra Ponces. (New York: Princeton Architectural Press, 2003), 196-125.

Gideon, S. *Mechanization Takes Command: A Contribution to Anonymous History* (New York: Oxford University Press, 1948).

Grothuis, J.D. "Cost-Function Relationships," *SAVE Conference—1977*, 224-26.

Hardt, M. and Weeks, K. eds. *The Jameson Reader* (Oxford, UK: Blackwell, 2002).

Jameson, F. *Post-Modernism, or the Cultural Logic of Late Capitalism* (Durham, NC: Duke University Press, 1991).

Jencks, C., ed. *The Post-Modern Reader* (New York: St. Martin's Press, 1992).

Korzybski, A. *Science and Sanity: an introduction to non-Aristotelian systems and general semantics*, 4<sup>th</sup> ed. (Lakeville, CN: International Non-Aristotelian Library Co., 1957).

Kranakis, E. *Constructing a Bridge: an exploration of engineering culture, design and research in 19<sup>th</sup> century France and America* (Cambridge, MA: MIT Press, 1997).

Martin, R. *The Organizational Complex: Architecture, Media and Corporate Space* (Cambridge, MA: MIT Press, 2003)

Latham, M.E. *Modernization as Ideology: American Social Science and "Nation Building"* (Chapel Hill: Univ. of N. Carolina Press, 2000);

Lewis, T. *Divided Highways* (New York: Viking, 1997).

Macedo, Jr., M.C, Dobrow, P.V., and J.O'Rourke, J. *Value Management for Construction, Construction Management and Engineering Series*, ed. John F. Peel Brahtz (New York: John Wiley & Sons, Inc., 1978), p. 3.

Miles, L. *Techniques of Value Analysis and Engineering* (New York: McGraw-Hill, 1961).

Miles, L. *Techniques of Value Analysis and Engineering*, 2<sup>nd</sup> ed, (New York: McGraw-Hill, 1972).

Alex Osborn, *Applied Imagination: Principles and Procedures of Creative Thinking*, 3<sup>rd</sup>. rev. ed., (New York: Scribner, 1979).

Podolny, Jr. W. and Scalzi, J.B. *Construction and Design of Cable-Stayed Bridges* (New York: John Wiley & Sons, Inc., 1986).

Scott, F., "End Games and Outer Limits," Myriam Bellazoug Lecture, Yale School of Architecture, Hastings Hall, New Haven, CT, Nov. 8, 2004.

Scott, R. *In the Wake of Tacoma: Suspension bridges and the Quest for aerodynamic stability* (Reston, VA: ASCE Press, 2001).

Seeley, B., "Changing Patterns of Research in American Engineering Colleges: The Social Dimension of the Rise of Engineering Science," *The Interaction between Technology and Science*, Bart Gremmen, ed. (Wageningen, The Netherlands: Wageningen Agricultural University, 1992), pp. 159-81.

Seeley, B., "State Engineers as Policymakers: Apolitical Experts in a Federalist System," Jerry Rogers, et. al., editors, *Civil Engineering History: Engineers Make History*, William Whyte, *The Organization Man* (New York: Simon & Schuster, 1956)

Weingroff, R., "The Greatest Decade Part 1: Essential to the National Interest, 1956-1966," <http://www.fhwa.dot.gov/infrastructure/50interstate.cfm>, December, 2006.

Weingroff, R., "The Battle of New Orleans-Vieux Carre Riverfront Expressway (I-410)" <http://www.fhwa.dot.gov/infrastructure/neworleans>.

Winfrey, R. *Economic Analysis for Highways* (Scranton, PA: International Textbook Co., 1969).

