

Interaction between Waves and Current

over a Variable Depth

by

François-Marc Turpin

Ingenieur diplômé de l'école Polytechnique (1979)  
DEA de Mécanique Théorique Université PARIS VI (1980)  
Ingenieur eleve de l'école des Ponts et chaussees

SUBMITTED TO THE DEPARTMENT OF  
CIVIL ENGINEERING IN PARTIAL  
FULFILLMENT OF THE  
REQUIREMENTS FOR THE  
DEGREE OF

MASTER OF SCIENCE



at the

MASSACHUSETTS INSTITUTE OF TECHNOLOGY

June 1981

© Massachusetts Institute of Technology

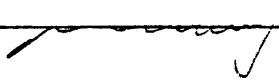
Signature of Author  Department of Civil Engineering  
May 20, 1981

Certified by  Chiang C. Mei  
Thesis Supervisor  

Accepted by  C. Allin Cornell  
Chairman, Department Committee

**Archives**  
MASSACHUSETTS INSTITUTE  
OF TECHNOLOGY

JUL 13 1981

LIBRARIES

INTERACTION BETWEEN WAVES AND CURRENT

OVER A VARIABLE DEPTH

by

FRANÇOIS-MARC TURPIN

Submitted to the Department of Civil Engineering  
on May 20, 1981 in partial fulfillment of the  
requirements for the degree of Master of Science

ABSTRACT

A theoretical study of water waves and current over variable depth is performed. Multiple-scales analysis is used to derive the equation governing the evolution of a 1-D wave packet. The current is assumed to be colinear with the wave number vector and with the depth gradient. The equation which is found is a cubic Schrödinger equation with nonconstant coefficients.

Some analytical properties of this equation are studied. The equation is then solved numerically and the effect of current and depth variation on the propagation of a solitary wave is studied.

Thesis Supervisor: Dr. Chiang C. Mei

Title: Professor of Civil Engineering

## ACKNOWLEDGMENTS

This study was funded by a fellowship from the French Ministere de l'equipement.

I wish to express my sincere appreciation to Professor C.C. Mei, my advisor and thesis supervisor, who provided a challenging scientific environment and who gave me much encouragement, insight, and guidance throughout the study.

I want also to thank Ms. Shawn Finnegan who typed the manuscript with great efficiency.

## TABLE OF CONTENTS

	PAGE
Title Page	1
Abstract	2
Acknowledgment	3
Table of Contents	4
Introduction	6
Part I: Derivation of the Equations	11
1. Derivation of the approximate equations	11
1.1. Equations for the current	11
1.2. Equations for the waves	12
2. Formal solution of the approximate equations	19
2.1. Method	19
2.2. Summary of the algebra	23
2.3. Concluding remarks	31
3. Evolution equation for special cases	34
3.1. No current	34
3.2. A stationary current	34
Part II: Analytical Study of the Evolution Equation	42
1. The case with constant coefficients	42
1.1. Generalities	42
1.2. Some special solutions of the cubic Schrödinger equation	43
2. The case with non-constant coefficients	47
2.1. A particular solution	48
2.2. Evolution laws	53
Part III: Numerical Study	57
1. The finite difference method	57

	PAGE
1.1. Preliminary algebra	57
1.2. Method used to solve the equation	58
1.3. Inversion scheme to solve the matrix equation	60
2. Numerical results	65
2.1. Variation of the coefficients	65
2.2. Study of the amplitude of the waves	67
2.2.1. Fission of a soliton ( $y_2 y_3 > 0$ everywhere)	71
2.2.2. Fission of two-bounded solitons ( $y_2 y_3 > 0$ everywhere)	83
2.2.3. Evolution of sech profile ( $y_2 y_3 < 0$ everywhere)	86
Conclusion of the numerical study	89
References	91
Appendix A: Condition for a steady current over a variable depth	93
Appendix B: Inverse Scattering Theory for the cubic Schrödinger equation	97
Appendix C: Proof of the theorem's state in Appendix B	113
Appendix D: Numerical tables	126
Appendix E: Computer program	142
List of figures and captions	151

## Introduction.

Depth variation and current both affect the propagation of waves. This interaction is of practical importance in coastal engineering. Structures are often constructed near a river mouth where currents may be important. Tidal currents near harbor entrance may have considerable effects on wave propagation and during ebb tides where waves are steepened by the opposing current, entrance of some harbors may be hazardous for small boats. Shoaling effect of submarine ridges may also enhance these effects. A comprehensive study of water waves and current interaction can be found in Peregrine (1976) [16].

In the present work our attention will be focused on small amplitude waves moving over strong current. In this case the current affects the waves but is not affected by the waves. We shall further assume, as is frequently the case in nature that the current and the depth vary on length and time scales which are much greater than the wave length and period of the waves.

The first theoretical description of such problem was given by Longuet-Higgins and Stewart (1960-61) [9] [10] [11] and Whitam (1962) [23]. They introduced the concept of radiation stress: it states that energy of waves over variable current is not conserved but is created or destroyed because of the rate of work done by the radiation stress and the current strain. Further extension has been made by Phillips (1966) [17] and Bretherton and Garrett (1968) [3] who introduced the concept of wave action.

All these studies are concerned with linear theory. In this thesis we shall derive nonlinear extension of the equation of conservation of

wave action. We extend the method used by Djordjevic and Redekopp (1978) [5] who studied nonlinear evolution of a wave packet moving over a variable depth. To adapt the method of multiple-scales to our problem we use the approach of Mei [12] who showed that the results of linear theory, found by using Whitam's theory of averaged Lagrangian, can be derived by assuming a WKB type expansion of the waves related quantities.

Let us first state the assumptions:

As usual in this kind of study we ignore viscosity and neglect the interaction between water and the air above. We also ignore surface tension.

One important simplification is that we consider a one dimensional problem. This assumption is not fundamental but is made to simplify the algebra which, even in this case is very lengthy. By this limitation our study is restricted to the case where the wave number  $\vec{k}$  and the velocity of the current  $\vec{U}$  are colinear. Therefore all the physical quantities to be considered are only functions of the vertical coordinate  $z$ , the only horizontal coordinate,  $x$  and time  $t$ .

Other assumptions are concerned with the different scales appearing in the problem:

- Length scales: There are 5 scales;  $L$ , the wave length;  $A$  the amplitude of the waves;  $h$  the averaged depth;  $\frac{\partial h}{\partial x}/h = \frac{1}{L_h}$ ,  $L_h$  is the length scale of depth variation;  $\frac{\partial U}{\partial x}/U = \frac{1}{L_u}$ ,  $L_u$  is the length scale of  $U$  variation where  $U$  is the current velocity.

- Time scales: There are 2 scales;  $T$  period of the waves;  $\frac{\partial U}{\partial t}/U = \frac{1}{T_u}$  where  $T_u$  is the time scale of  $U$  variations.

As usual we mean by "length scale of  $U$  variation" the length over which  $U$  varies by  $O(U)$ . As the main object of this work is to study the

direct effect of depth variation on waves, the waves must "feel" the bottom. In other words we are not interested in the deep water limit  $h \gg L$ . (However, even if  $h \gg L$  the current can feel the depth variation which will affect the waves indirectly.) For these reasons we take  $L = O(h) = O(1)$ .

As usual the study is restricted to weakly nonlinear waves; this implies the wave's amplitude to be small or, more precisely  $kA = \frac{2\pi A}{L} = \epsilon \ll 1$  where  $k = \frac{2\pi}{L}$  is the wave number. This means that the slope of the waves is small. All the quantities related to the waves are  $O(\epsilon)$  but they vary rapidly, i.e., their length and time scales of variation are  $O(L)$  and  $O(T)$  which are taken as  $O(1)$ . In other words all the quantities related to the waves can be written:

$$f_w(x, z, t) = \epsilon \bar{f}_w(x, z, t)$$

The depth is assumed to vary very slowly: its variation is negligible over one wave length. This implies  $L_h \gg L$ . More precisely we assume  $\frac{h}{L_h} = O(\epsilon^2)$ . The pertinent coordinate for  $h$  is then  $x_2 = \epsilon^2 x$ , i.e.,  $h = h(x_2)$ .

The current is assumed to be strong: all the quantities related to the current are  $O(1)$ . We also assume that it varies very slowly both in space and time. This means:  $L_u \gg L$ ;  $T_u \gg T$ . This can be a very realistic assumption. As the variations of the current are expected to be the consequence of the depth variation we assume that:

$$\frac{L}{L_u} = O(\epsilon^2) \quad \frac{T}{T_u} = O(\epsilon^2)$$

The pertinent coordinates for the quantities related to the current are therefore:



$x_2 = \varepsilon^2 x$ ,  $t_2 = \varepsilon^2 t$  and  $z$  (As  $h = O(1)$  we do not allow slow variations in  $z$ .)

In the first part of this work we derive the equations governing the evolutions of the amplitude of the waves. We first find the approximate equations of the problem at  $O(\varepsilon^3)$ ; then we solve these equations in a formal and asymptotic sense by assuming expansions in power of  $\varepsilon$  of all the quantities related to the waves. As usual we expect some slow variations of these quantities. This is taken into account by using multiple scales analysis. After a very lengthy algebra we find the equation governing the evolution of a wave packet. It is a kind of cubic Schrödinger equation with nonconstant coefficients. We then compare this equation with those already known in the literature: the linear limit and the case without current.

In the second part we turn to an analytical study of the evolution equation in the limited case where the current is stationary. We first recall some results when the coefficients of the equation are constant. In particular we present in Appendix B, C an account of the Inverse Scattering theory by which our equation can be exactly solved. When the coefficients are not constant the analytical study is much more limited. Our results are limited to the study of an exact solution which is an extension of the well known Stoke's waves. Certain evolution laws are then derived which are the equivalent of the well known conservation laws for the cubic Schrödinger equation.

To find some more qualitative answers we turn in the third part to a numerical study of the problem. It is found that a recent study in reference [5] which is based on very stringent assumptions is not supported by the numerical results. Finally we present some new results showing how the envelope of a wave packet evolves when it propagates over a

region where the depth and the current both vary.

PART I: DERIVATION OF THE EQUATIONS

1. Derivation of the Approximate Governing Equations.

In this section we will derive the approximate equations governing the evolution of the slowly varying strong current and of the small amplitude waves. The method is an extension of the method used in reference [12] where the nonlinear terms have been neglected.

1.1. Equations for the current.

First we consider the current without waves; as the variables are:

$$\left\{ \begin{array}{l} \vec{U}_c = (U_c(x,z,t), W_c(x,z,t)) \text{ (horizontal and vertical component)} \\ \zeta_c(x,t) \text{ elevation of the free surface above the undisturbed free surface } Z = 0. \end{array} \right.$$

As explained previously we assume that:

- $\vec{U}_c = 0(1)$
- Length scale of x variation is  $L_x = 0\left(\frac{1}{\epsilon^2}\right)$  for  $U_c$ ,  $\zeta_c$  and  $h$ . The pertinent coordinate is then  $x_2 = \epsilon^2 x$
- Characteristic time scale is  $T = 0\left(\frac{1}{\epsilon^2}\right)$  for  $U_c$ ,  $\zeta_c$ . The pertinent coordinate is then  $t_2 = \epsilon^2 t$ .
- Length scale of z variation is  $L_z = 0(1)$ . The pertinent coordinate is then  $z$ .

With these assumptions we may write  $\vec{U}_c = \vec{U}_c(x_2, z, t_2)$ ,  $\zeta_c = \zeta_c(x_2, t_2)$  and  $h = h(x_2)$ . It is then well known that, if the current is irrotational or weakly rotational, then  $U_c$  and  $\zeta_c$  are solutions of the Airy's equations governing evolution of long waves. More precisely by using the results of reference [12] we have:

$$\begin{cases} U_c(x_2, z, t_2) = U(x_2, t_2) + O(\epsilon^4) \\ W_c(x_2, z, t_2) = O(\epsilon^2) \\ \zeta_c(x_2, t_2) = \zeta(x_2, t_2) \\ P(x_2, z, t_2) = \rho g(\zeta(x_2, t_2) - Z) + O(\epsilon^4) \end{cases} \quad (1-1)$$

Where  $U$  and  $\zeta$  are governed by Airy's equations:

$$\begin{cases} \frac{\partial \zeta}{\partial t_2} + \frac{\partial}{\partial x_2} [(\zeta + h)U] = 0 \\ \frac{\partial U}{\partial t_2} + \frac{U \partial U}{\partial x_2} + g \frac{\partial \zeta}{\partial x_2} = 0 \end{cases} \quad (1-2)$$

Once  $U$  is found we obtain  $W_c$  from the continuity equation  $\frac{\partial W_c}{\partial z} + \frac{\partial U_c}{\partial x} = 0$  and the boundary condition at the bottom  $W_c = -h'(x)U_c$  at  $Z = -h(x)$ .

$$\begin{aligned} W_c(x_2, z, t_2) &= \epsilon^2 \left[ - \int_{-h(x_2)}^z \frac{\partial U}{\partial x_2} dz - h'(x)U(x_2, t_2) \right] + O(\epsilon^4) \\ &= \epsilon^2 \left[ - \frac{\partial U}{\partial x_2} (Z + h(x_2)) - h'(x_2) U(x_2, t_2) \right] + O(\epsilon^4) \\ &= W(x_2, z, t_2) + O(\epsilon^4) \end{aligned} \quad (1-3)$$

At this point we have the equation for the current at  $O(\epsilon^3)$ .

## 1.2. Equations for the waves.

Let us now superpose waves on the current.

$$U_{\text{total}} = U_c + u$$

$$W_{\text{total}} = W_c + w$$

$$P_{\text{total}} = P_c + p$$

$$\zeta_{\text{total}} = \zeta_c + \eta$$

where  $u$ ,  $w$ ,  $p$  and  $\eta$  are quantities related to the waves which are supposed to be of order  $\epsilon$  but whose typical scale of variation with respect to  $x$ ,  $z$  and  $t$  is  $O(1)$ . So we have  $u(x, z, t)$ ,  $w(x, z, t)$ ,  $p(x, z, t)$ ,  $\eta(x, z, t)$

and  $\frac{\partial}{\partial x}$ ,  $\frac{\partial}{\partial z}$  and  $\frac{\partial}{\partial t}$  are  $O(1)$  when they operate on these quantities.

To get the equations governing the waves we substitute the expressions for  $\vec{U}_{\text{total}}$ ,  $P_{\text{total}}$  and  $\zeta_{\text{total}}$  into the equations of motion. As the current quantities are known up to  $O(\epsilon^3)$  we shall be able to keep the wave related quantities to the third order in  $\epsilon$ .

i. Momentum equations and continuity equation.

If the expressions for  $U_{\text{total}}$  and  $P_{\text{total}}$  are inserted in the inviscid momentum equations we obtain, after using the fact that, by definition

$U_c$ ,  $W_c$ ,  $P_c$  are exact solutions of the equations of motion:

x - component of momentum equation

$$\frac{\partial u}{\partial t} + u \frac{\partial U_c}{\partial x} + w \frac{\partial U_c}{\partial z} + U_c \frac{\partial u}{\partial x} + W_c \frac{\partial u}{\partial z} + u \frac{\partial u}{\partial x} + w \frac{\partial u}{\partial z} = - \frac{1}{\rho} \frac{\partial p}{\partial x} \quad (1-4)$$

Now we use the fact that

$$U_c = U(x_2, t_2) + O(\epsilon^4)$$

$$W_c = W(x_2, z, t_2) + O(\epsilon^4) \text{ where } W \text{ is } O(\epsilon^2)$$

then  $\frac{\partial U_c}{\partial z} = O(\epsilon^4) \Rightarrow w \frac{\partial U_c}{\partial z} = O(\epsilon^5)$

therefore:

$$\frac{\partial u}{\partial t} + u \frac{\partial U}{\partial x} + U \frac{\partial u}{\partial x} + W \frac{\partial u}{\partial z} + u \frac{\partial u}{\partial x} + w \frac{\partial u}{\partial z} = - \frac{1}{\rho} \frac{\partial p}{\partial x} + O(\epsilon^5) \quad (1-5)$$

z - component of momentum equation

$$\frac{\partial w}{\partial t} + u \frac{\partial W_c}{\partial x} + w \frac{\partial W_c}{\partial z} + U_c \frac{\partial w}{\partial x} + W_c \frac{\partial w}{\partial z} + u \frac{\partial w}{\partial x} + w \frac{\partial w}{\partial z} = - \frac{1}{\rho} \frac{\partial p}{\partial z} \quad (1-6)$$

Because:

$$\frac{\partial W_c}{\partial x} = \frac{\partial W}{\partial x} + O(\epsilon^4) = O(\epsilon^4) \text{ since } W = W(x_2, z, t_2) \text{ where } W \text{ is } O(\epsilon^2)$$

equation (1-6) gives

$$\frac{\partial w}{\partial t} + w \frac{\partial W}{\partial z} + U \frac{\partial w}{\partial x} + W \frac{\partial w}{\partial z} + u \frac{\partial w}{\partial x} + w \frac{\partial w}{\partial z} = - \frac{1}{\rho} \frac{\partial p}{\partial z} + O(\epsilon^5) \quad (1-7)$$

continuity equation: we have exactly

$$\frac{\partial u}{\partial x} + \frac{\partial w}{\partial z} = 0 \quad (1-8)$$

Let us now take  $\frac{\partial}{\partial x}$  (1-5) +  $\frac{\partial}{\partial z}$  (1-7), yielding

$$\begin{aligned} \frac{\partial^2 p}{\partial x^2} + \frac{\partial^2 p}{\partial z^2} = & - \rho \left\{ \frac{\partial^2 u}{\partial x \partial t} + \frac{\partial u}{\partial x} \frac{\partial U}{\partial x} + u \frac{\partial^2 U}{\partial x^2} + \frac{\partial U}{\partial x} \frac{\partial u}{\partial x} + U \frac{\partial^2 u}{\partial x^2} + \frac{\partial W}{\partial x} \frac{\partial u}{\partial z} + W \frac{\partial^2 u}{\partial x \partial z} \right. \\ & + \frac{\partial u}{\partial x} \frac{\partial u}{\partial x} + u \frac{\partial^2 u}{\partial x^2} + \frac{\partial w}{\partial x} \frac{\partial u}{\partial z} + w \frac{\partial^2 u}{\partial x \partial z} + \frac{\partial^2 w}{\partial z \partial t} + \frac{\partial w}{\partial z} \frac{\partial W}{\partial z} + w \frac{\partial^2 W}{\partial z^2} + \frac{\partial U}{\partial z} \frac{\partial w}{\partial x} \\ & \left. + U \frac{\partial^2 w}{\partial x \partial z} + \frac{\partial W}{\partial z} \frac{\partial w}{\partial z} + W \frac{\partial^2 w}{\partial z^2} + \frac{\partial u}{\partial z} \frac{\partial w}{\partial x} + u \frac{\partial w}{\partial z \partial x} + \frac{\partial w}{\partial z} \frac{\partial w}{\partial z} + w \frac{\partial^2 w}{\partial z^2} \right\} \quad (1-9) \end{aligned}$$

Then by using (1-8)

$$\left\{ \begin{array}{l} U = U(x_2, t_2) \\ W = O(\epsilon^2) \\ \text{and } \frac{\partial U}{\partial x} + \frac{\partial W}{\partial z} = O(\epsilon^4) \Rightarrow \frac{\partial^2 W}{\partial z^2} = - \frac{\partial^2 U}{\partial x \partial z} + O(\epsilon^4) = O(\epsilon^4) \Rightarrow \\ w \frac{\partial^2 W}{\partial z^2} = O(\epsilon^5) \end{array} \right.$$

equation (1-9) can be written as

$$\frac{\partial^2 p}{\partial x^2} + \frac{\partial^2 p}{\partial z^2} = - \rho \left\{ 2 \frac{\partial u}{\partial x} \frac{\partial U}{\partial x} + 2 \frac{\partial w}{\partial z} \frac{\partial W}{\partial z} + \frac{\partial u}{\partial x} \frac{\partial u}{\partial x} + 2 \frac{\partial w}{\partial x} \frac{\partial u}{\partial z} + \frac{\partial w}{\partial z} \frac{\partial w}{\partial z} \right\} + O(\epsilon^5)$$

By further use of the continuity equation, we get

$$\nabla^2 p = - \rho \left\{ 4 \frac{\partial u}{\partial x} \frac{\partial U}{\partial x} + 2 \frac{\partial u}{\partial x} \frac{\partial u}{\partial x} + 2 \frac{\partial w}{\partial x} \frac{\partial u}{\partial z} \right\} + O(\epsilon^5) \text{ for } -h < z < \zeta + \eta \quad (1-10)$$

which is the governing equation for p.

ii. Boundary conditions.

On the bottom:  $\vec{U}_{\text{total}} \cdot \vec{n} = 0$  at  $z = -h(x)$  where  $\vec{n}$  is the normal to the depth profile at the point  $x$ . Alternatively we may write:

$$W_{\text{total}} + h'(x) U_{\text{total}} = 0 \quad (1-11)$$

As  $U_c$  and  $W_c$  satisfy this condition exactly we must have:

$$w = -h'(x)u \text{ at } z = -h(x) \quad (1-12)$$

Let us take  $\frac{\partial}{\partial x}$  of this equation as  $\frac{\partial f(x, -h(x), t)}{\partial x} = \frac{\partial f}{\partial x} - h'(x) \frac{\partial f}{\partial z}$  we get

$$\frac{\partial w}{\partial x} - h'(x) \frac{\partial w}{\partial z} = - \frac{\partial u}{\partial x} h'(x) + \frac{\partial u}{\partial z} h'(x)^2 - \frac{\partial u}{\partial x} h''(x) = - \frac{\partial u}{\partial x} h'(x) + O(\epsilon^5) \quad (1-13)$$

since  $h'(x) = O(\epsilon^2)$  and  $h''(x) = O(\epsilon^4)$  it follows from the z-momentum equation that:

$$\begin{aligned} - \frac{1}{\rho} \frac{\partial p}{\partial z} &= - \frac{\partial u}{\partial t} h'(x) - w \frac{\partial U}{\partial x} + W \frac{\partial w}{\partial z} + U h'(x) \frac{\partial w}{\partial z} - U \frac{\partial u}{\partial x} h'(x) \\ &+ u \frac{\partial w}{\partial x} + w \frac{\partial w}{\partial z} + O(\epsilon^5) \text{ at } z = -h(x) \end{aligned} \quad (1-14)$$

where use has been made of:

$$\begin{cases} w = -h'(x)u \text{ at } z = -h(x) \\ \frac{\partial w}{\partial x} = - \frac{\partial u}{\partial x} h'(x) + \frac{\partial w}{\partial z} h'(x) + O(\epsilon^5) \text{ at } z = -h(x) \end{cases}$$

and the continuity equation for  $U, W$ .

Since  $w, \frac{\partial w}{\partial x}$  and  $\frac{\partial w}{\partial z}$  are  $O(\epsilon^3)$  while  $W + Uh'(x) = O(\epsilon^4)$  at the bottom, equation (1-14) gives:

$$- \frac{1}{\rho} \frac{\partial p}{\partial z} = -h'(x) \left\{ \frac{\partial u}{\partial t} + U \frac{\partial u}{\partial x} \right\} + O(\epsilon^4) \text{ at } z = -h(x) \quad (1-15)$$

Since the x-component of the momentum equation gives

$$-\frac{1}{\rho} \frac{\partial p}{\partial x} = \frac{\partial u}{\partial t} + U \frac{\partial u}{\partial x} + O(\epsilon^2) \Rightarrow$$

$$h'(x) \left\{ \frac{\partial u}{\partial t} + U \frac{\partial u}{\partial x} \right\} = -\frac{h'(x)}{\rho} \frac{\partial p}{\partial x} + O(\epsilon^4)$$

The boundary condition at the bottom then becomes

$$-\frac{\partial p}{\partial z} = h'(x) \frac{\partial p}{\partial x} + O(\epsilon^4) \text{ at } z = -h(x) \quad (1-16)$$

Kinematic condition at the free surface  $Z = \zeta + \eta$

The statement that a fluid particle which is on the free surface initially stays always on the free surface can be written as:

$$\frac{\partial \zeta_{\text{total}}}{\partial t} + U_{\text{total}} \frac{\partial \zeta_{\text{total}}}{\partial x} = W_{\text{total}} \text{ at } z = \zeta_{\text{total}} \quad (1-17)$$

By using the expression of  $\vec{U}_{\text{total}}$ ,  $\zeta_{\text{total}}$  and the approximations for  $\vec{U}_c$ ,  $\zeta_c$ , (1-17) gives:

$$\frac{\partial \zeta}{\partial t} + \frac{\partial \eta}{\partial t} + (U + u) \frac{\partial \zeta + \eta}{\partial x} = W + w \text{ at } z = \zeta + \eta \quad (1-18)$$

Let us perform Taylor series expansion of the various functions about  $z = \zeta$

- $U(z = \zeta + \eta) = U(z = \zeta)$  being independent of  $z$
- $W(z = \zeta + \eta) = W(z = \zeta) + \eta \frac{\partial W}{\partial z} (z = \zeta) + \frac{\eta^2}{2} \frac{\partial^2 W}{\partial z^2} (z = \zeta) + \dots$

$$(1-19)$$

Since  $W = O(\epsilon^2)$  and  $\eta = O(\epsilon)$ , it follows that

$$W(z = \zeta + \eta) = W(z = \zeta) + \eta \frac{\partial W}{\partial z} (z = \zeta) + O(\epsilon^4) \quad (1-20)$$

$$\cdot w(z = \zeta + \eta) = w(z = \eta) + \eta \frac{\partial w}{\partial z} (z = \eta) + \frac{\eta^2}{2} \frac{\partial^2 w}{\partial z^2} (z = \eta) + O(\epsilon^4) \quad (1-21)$$



$$\cdot \frac{\partial \zeta}{\partial x} u(z = \zeta + \eta) = \frac{\partial \zeta}{\partial x} u(z = \zeta) + O(\epsilon^4) \text{ since } \frac{\partial \zeta}{\partial x} = O(\epsilon^2) \text{ u} = O(\epsilon) \quad (1-22)$$

$$\cdot \frac{\partial}{\partial x} u(z = \zeta + \eta) = \frac{\partial \eta}{\partial x} u(z = \zeta) + \eta \frac{\partial \eta}{\partial x} \frac{\partial u}{\partial z}(z = \zeta) + O(\epsilon^4) \quad (1-23)$$

By using the condition  $\frac{\partial \zeta}{\partial t} + U \frac{\partial \zeta}{\partial x} = W + O(\epsilon^4)$  at  $z = \zeta$  and

$$\frac{\partial U}{\partial x} + \frac{\partial W}{\partial z} = O(\epsilon^4) \quad (1-24)$$

the kinematic boundary condition at the free surface takes the form

$$\begin{aligned} \frac{\partial \eta}{\partial t} + u \frac{\partial \zeta}{\partial x} + U \frac{\partial \eta}{\partial x} = -\eta \frac{\partial U}{\partial x} + w + \eta \frac{\partial w}{\partial z} - u \frac{\partial \eta}{\partial x} - \eta \frac{\partial \eta}{\partial x} \frac{\partial u}{\partial z} + \frac{\eta^2}{2} \frac{\partial^2 w}{\partial z^2} \\ + O(\epsilon^4) \text{ at } z = \zeta \end{aligned} \quad (1-25)$$

Dynamic condition at the free surface  $z = \zeta + \eta$

Supposing the atmospheric pressure to be constant, the dynamic condition at the free surface can be written as:

$$\frac{dP_{\text{total}}}{dt} = 0 \text{ at } z = \zeta + \eta \quad (1-26)$$

Using (1-1) we have

$$P_{\text{total}} = p + g(\zeta - z) + O(\epsilon^4)$$

Therefore

$$\begin{aligned} \frac{dP_{\text{total}}}{dt} = \frac{\partial p}{\partial t} + (U + u) \frac{\partial p}{\partial x} + (W + w) \frac{\partial p}{\partial z} + \rho g \left\{ \frac{\partial}{\partial t} + (U + u) \frac{\partial}{\partial x} + (W + w) \frac{\partial}{\partial z} \right\} \\ (\zeta - z) + O(\epsilon^4) \end{aligned} \quad (1-27)$$

where use has been made of  $U_{\text{total}} = U + u + O(\epsilon^4)$   $W_{\text{total}} = W + w + O(\epsilon^4)$

Equation (1-26) then states:

$$\begin{aligned} \frac{\partial p}{\partial t} + U \frac{\partial p}{\partial x} + u \frac{\partial p}{\partial x} + W \frac{\partial p}{\partial z} + w \frac{\partial p}{\partial z} + \rho g \left\{ \frac{\partial \zeta}{\partial t} + U \frac{\partial \zeta}{\partial x} + u \frac{\partial \zeta}{\partial x} - W - w \right\} \\ + O(\epsilon^4) = 0 \text{ at } z = \zeta + \eta \end{aligned}$$

Let us again perform Taylor series expansion about  $z = \zeta$  for all the quantities.

$$\cdot \frac{\partial \zeta}{\partial x} U(z = \zeta + \eta) = \frac{\partial \zeta}{\partial x} U(z = \zeta) \text{ since } U \text{ does not depend on } z \quad (1-29)$$

$$\cdot W(z = \zeta + \eta) = W(z = \zeta) + \eta \frac{\partial W}{\partial z} (z = \zeta) + O(\epsilon^4) \text{ since } W = O(\epsilon^2) \quad (1-30)$$

$$\cdot \frac{\partial \zeta}{\partial x} u(z = \zeta + \eta) = \frac{\partial \zeta}{\partial x} u(z = \zeta) \text{ since } \frac{\partial \zeta}{\partial x} = O(\epsilon^2) \text{ } u = O(\epsilon) \quad (1-31)$$

$$\begin{aligned} \cdot U \frac{\partial p}{\partial x} (z = \zeta + \eta) + U(z = \zeta) \left\{ \frac{\partial p}{\partial x} (z = \zeta) + \eta \frac{\partial^2 p}{\partial z \partial x} (z = \zeta) \right. \\ \left. + \frac{\eta^2}{2} \frac{\partial^3 p}{\partial z^2 \partial x} (z = \zeta) \right\} + O(\epsilon^4) = U \frac{\partial p}{\partial x} + U \eta \frac{\partial^2 p}{\partial z \partial x} + U \frac{\eta^2}{2} \frac{\partial^3 p}{\partial z^2 \partial x} \\ + O(\epsilon^4) \text{ at } z = \zeta \end{aligned} \quad (1-32)$$

since  $U$  does not depend on  $z$ .

$$\cdot W \frac{\partial p}{\partial z} (z = \zeta + \eta) = W \frac{\partial p}{\partial z} (z = \zeta) + O(\epsilon^4) \text{ since } W = O(\epsilon^2) \text{ } p = O(\epsilon) \quad (1-33)$$

$$\cdot w \frac{\partial p}{\partial z} (z = \zeta + \eta) = w \frac{\partial p}{\partial z} + \frac{\partial p}{\partial z} \eta \frac{\partial w}{\partial z} + w \eta \frac{\partial^2 p}{\partial z^2} + O(\epsilon^4) \text{ at } z = \zeta \quad (1-34)$$

$$\cdot u \frac{\partial p}{\partial x} (z = \zeta + \eta) = u \frac{\partial p}{\partial x} + \frac{\partial p}{\partial x} \eta \frac{\partial u}{\partial z} + u \eta \frac{\partial^2 p}{\partial z \partial x} + O(\epsilon^4) \text{ at } z = \zeta \quad (1-35)$$

$$\cdot \frac{\partial p}{\partial t} (z = \zeta + \eta) = \frac{\partial p}{\partial t} + \eta \frac{\partial^2 p}{\partial t \partial z} + \frac{\eta^2}{2} \frac{\partial^3 p}{\partial z^2 \partial t} + O(\epsilon^4) \text{ at } z = \zeta \quad (1-36)$$

The dynamic boundary condition therefore reads:

$$\begin{aligned} \frac{\partial p}{\partial t} + \eta \frac{\partial^2 p}{\partial t \partial z} + \frac{\eta^2}{2} \frac{\partial^3 p}{\partial t \partial z^2} + U \frac{\partial p}{\partial x} + U \eta \frac{\partial^2 p}{\partial z \partial x} + U \frac{\eta^2}{2} \frac{\partial^3 p}{\partial z^2 \partial x} + u \frac{\partial p}{\partial x} + \eta \frac{\partial p}{\partial x} \frac{\partial u}{\partial z} \\ + u \eta \frac{\partial^2 p}{\partial x \partial z} + w \frac{\partial p}{\partial z} + \frac{\partial p}{\partial z} \eta \frac{\partial w}{\partial z} + w \eta \frac{\partial^2 p}{\partial z^2} + \rho g u \frac{\partial \zeta}{\partial x} + W \frac{\partial p}{\partial z} + \rho g \eta \frac{\partial U}{\partial x} \\ - \rho g \left\{ w + \eta \frac{\partial w}{\partial z} + \frac{\eta^2}{2} \frac{\partial^2 w}{\partial z^2} \right\} = O(\epsilon^4) \text{ at } z = \zeta \end{aligned} \quad (1-37)$$

where use has been made of the continuity equation for the current

$$\frac{\partial W}{\partial z} = - \frac{\partial U}{\partial x} + O(\epsilon^4)$$

## 2. Formal Solution of the Approximate Equations.

### 2.1. Method.

To solve the problem we assume, for all the quantities which are related to the waves, an expansion in power of  $\epsilon$ .  $f(x,z,t) = \sum_{n=1}^{\infty} \epsilon^n f^{(n)}(x,z,t)$ . However, for physical and mathematical reasons we make some assumptions on the form of the  $f^{(n)}$ : at the first order we consider waves with frequency  $\omega$  and wavenumber  $k$ . As the medium varies slowly in  $x$  and  $t$ , we expect  $k$  and  $\omega$  to vary slowly.

$$k = k(x_2, t_2) \quad \omega = \omega(x_2, t_2) \quad \text{where } x_2 = \epsilon^2 x \quad t_2 = \epsilon^2 t$$

The variations of  $k$  and  $\omega$  are related by the law of conservation of waves:

$$\frac{\partial k}{\partial t_2} + \frac{\partial \omega}{\partial x_2} = 0 \quad (2-1)$$

This wave is supposed to propagate from  $x = -\infty$  to  $+\infty$ , its form must be:

$A \exp(i \phi(x_2, t_2)) + \text{complex conjugate.}$

$\phi$  being defined by  $k(x_2, t_2) = \phi_{x_2} > 0$   $\omega(x_2, t_2) = -\phi_{t_2}$  so we may write

$$\phi(x_2, t_2) = \frac{1}{\epsilon} \psi(x_2, t_2) \quad \text{and then } k(x_2, t_2) = \psi_{x_2} \quad \omega(x_2, t_2) = \psi_{t_2}$$

We neglect the reflected waves due to the depth variation (they are assumed to be  $O(\epsilon^4)$ ).

The amplitude of the waves is expected to vary slowly in  $x$  and  $t$ . In the spirit of multiple scales analysis, see for instance reference [13]

we write the amplitudes as  $A(x_1, t_1, z, x_2, t_2)$  where  $x_1 = \epsilon x$   $t_1 = \epsilon t$   
 $x_2 = \epsilon^2 x$   $t_2 = \epsilon^2 t$ . We restrict ourselves to the study of a very slowly varying wave packet of length  $\frac{1}{\epsilon}$  propagating at the very slowly varying velocity  $Cg(x_2, t_2)$

$$A = A(x_2, t_2, z, \tau) \quad \text{where } \tau = \epsilon \left( \int^x \frac{dx}{Cg(x_2, t_2)} - t \right) \quad (2-2)$$

Because of nonlinearity in the equations we expect, as usual in this kind of problem that at  $O(\epsilon^n)$  all the harmonic

$$\exp i m \phi \quad m = -n, \dots, +n$$

will be present for these reasons we seek an expansion of the form:

$$\begin{aligned}
 p(x, z, t) &= \sum_{n=1}^{\infty} \epsilon^n \sum_{m=-n}^{+n} p_{nm}(x_2, t_2, z, \tau) \exp i m \phi \\
 u(x, z, t) &= \sum_{n=1}^{\infty} \epsilon^n \sum_{m=-n}^{+n} u_{nm}(x_2, t_2, z, \tau) \exp i m \phi \\
 w(x, z, t) &= \sum_{n=1}^{\infty} \epsilon^n \sum_{m=-n}^{+n} w_{nm}(x_2, t_2, z, \tau) \exp i m \phi \\
 \eta(x, t) &= \sum_{n=1}^{\infty} \epsilon^n \sum_{m=-n}^{+n} \eta_{nm}(x_2, t_2, \tau) \exp i m \phi
 \end{aligned} \tag{2-3}$$

Since all the quantities are real we must have:

$$p_{n,-m} = p_{nm}^*, \quad u_{n,-m} = u_{nm}^*, \quad w_{n,-m} = w_{nm}^*, \quad \eta_{n,-m} = \eta_{nm}^*$$

where \* means complex conjugate.

We substitute these expressions for  $p$ ,  $u$ ,  $w$ , and  $\eta$  in the governing equations and boundary conditions (6 equations). As is well known in the method of multiple scales the following rules on the derivatives should be noted:

i. When operating on a quantity related to the current:

$$\frac{\partial}{\partial x} \rightarrow \epsilon^2 \frac{\partial}{\partial x_2} \quad ; \quad \frac{\partial}{\partial t} \rightarrow \epsilon \frac{\partial}{\partial t_2} \tag{2-4}$$

ii. When operating on the  $m^{\text{th}}$  harmonic of a quantity related to the waves:

$$\frac{\partial}{\partial x} \rightarrow imk ( ) + \epsilon \frac{1}{C_g} \frac{\partial}{\partial \tau} + \epsilon^2 \frac{\partial}{\partial x_2} \quad (2-5)$$

$$\begin{aligned} \frac{\partial^2}{\partial x^2} \rightarrow & -m^2 k^2 ( ) + \epsilon \frac{2imk}{C_g} \frac{\partial}{\partial \tau} + \epsilon^2 2imk \frac{\partial}{\partial x_2} + im \frac{\partial k}{\partial x_2} ( ) \\ & + \frac{1}{C_g^2} \frac{\partial^2}{\partial \tau^2} \end{aligned} \quad (2-6)$$

$$\frac{\partial}{\partial t} \rightarrow -im\omega ( ) - \epsilon \frac{\partial}{\partial \tau} + \epsilon^2 \frac{\partial}{\partial t_2} \quad (2-7)$$

As the 6 equations (1-5, 8, 10, 16, 25, 37) are valid up to  $O(\epsilon^3)$  we expand  $p, u, w, \eta$  to the third order. All the equations then take the following form:

$$\sum_{n=1}^3 \epsilon^n \sum_{m=-n}^{+n} E_{i,n,m} \exp im\phi + O(\epsilon^4) = 0 \text{ for } i = 1, \dots, 6 \quad (2-8)$$

Since these equations are valid for any small  $\epsilon$  and since  $E_{i,n,-m} =$

$E_{i,n,m}^*$ , at each order we have  $6(n+1)$  equations:

$$E_{i,n,m} = 0 \quad i = 1, \dots, 6 \quad m = 0, 1, 2, \dots, n; \quad n = 1, 2, 3 \quad (2-9)$$

To see how this procedure works let us recall the form of the equations governing the waves.

$$(1-10) \quad \nabla^2 p = \text{Nonlinear terms} - \rho \frac{\partial u}{\partial x} \frac{\partial U}{\partial x}$$

$$(1-5) \quad \text{x-momentum} \quad \frac{\partial u}{\partial t} + U \frac{\partial u}{\partial x} + \frac{1}{\rho} \frac{\partial p}{\partial x} = \text{Nonlinear terms} - u \frac{\partial U}{\partial z} - W \frac{\partial u}{\partial z}$$

$$(1-8) \quad \text{continuity} \quad \frac{\partial w}{\partial z} = - \frac{\partial u}{\partial x}$$

$$(1-16) \quad \text{bottom boundary condition} \quad \frac{\partial p}{\partial z} = h'(x) \frac{\partial p}{\partial x}$$

Free surface kinematic condition:

$$(1-25) \quad \frac{\partial \eta}{\partial t} + U \frac{\partial \eta}{\partial x} - w = \text{Nonlinear terms} - u \frac{\partial \zeta}{\partial x} - \eta \frac{\partial U}{\partial x}$$

Free surface dynamic condition:

$$(1-37) \quad \frac{\partial p}{\partial t} + U \frac{\partial p}{\partial x} - \rho g w = \text{Nonlinear terms} - \rho g u \frac{\partial \zeta}{\partial x} - W \frac{\partial p}{\partial z} + \rho g \eta \frac{\partial U}{\partial x}$$

As  $\frac{\partial U}{\partial x}$ ,  $W$ ,  $\frac{\partial \zeta}{\partial x}$  and  $h'(x)$  are all  $O(\epsilon^2)$  it is obvious that if we take the  $m^{\text{th}}$  harmonic of the  $n^{\text{th}}$  order of each equation (i.e.,  $E_{inm} = 0 \quad i = 1, \dots, 6$ )

we obtain:

$$(1-10) \Rightarrow (a) \quad \left( \frac{\partial^2}{\partial z^2} - m^2 k^2 \right) p_{nm} = \text{L.O.T}$$

$$(1-5) \Rightarrow (b) \quad im(kU - \omega) u_{nm} + \frac{imk}{\rho} p_{nm} = \text{L.O.T}$$

$$(1-8) \Rightarrow (c) \quad \frac{\partial w_{nm}}{\partial z} = - imk u_{nm} = \text{L.O.T}$$

$$(1-16) \Rightarrow (d) \quad \frac{\partial p_{nm}}{\partial z} = \text{L.O.T} \quad \text{at } z = -h$$

$$(1-25) \Rightarrow (e) \quad im(kU - \omega) \eta_{nm} - w_{nm} = \text{L.O.T} \quad \text{at } z = \zeta$$

$$(1-37) \Rightarrow (f) \quad im(kU - \omega) p_{nm} - \rho g w_{nm} = \text{L.O.T} \quad \text{at } z = \zeta$$

where L.O.T means lower order terms which only involve terms of order lower than  $n$ .

It is now easy to describe the procedure: once the problems at order 1, 2, . . .  $n - 1$  are solved we solve the problem at order  $n$  in 4 steps.

1) We solve the vertical problem (a) and (d) for  $p_{nm}$   $m = 0, \dots, n$   
 This introduces some arbitrary functions of horizontal coordinates.

2) With (b) and (c) we find  $u_{nm}$  and  $w_{nm}$

3) With (e) we find  $\eta_{nm}$

4) (f) gives a constraint which determines the arbitrary functions introduced at lower order.

We note in particular that the zeroth harmonics  $u_{n0}$  and  $\eta_{n0}$  cannot be found at order  $n$  since their coefficients on the left of (b), (e) vanish. We will see that  $u_{n0}$  and  $\eta_{n0}$  are given by using (b) and (e) at order  $n + 1$ .

## 2.2. Summary of the algebra.

The method explained previously has the advantage of being systematic and of giving us the exact degree of approximation of the solution. But it has the disadvantage of being very lengthy. For this reason we do not present all the algebra but only all the results at each step. For brevity, we shall make repeated references to the equations (a), (b), . . . (f) given at the end of the previous section.

$O(\varepsilon)$

(a) + (d) give:

$$m = 0 \quad p_{10} = p_{10}(x_2, t_2, \tau) \text{ arbitrary function} \quad (2-10)$$

$$m = 1 \quad p_{11} = A(x_2, t_2, \tau) \frac{\cosh k(z + h)}{\cosh k(\zeta + h)} \quad (2-11)$$

where  $A$  is an arbitrary function.

(b) gives:

$$m = 0 \quad 0 = 0$$

$$m = 1 \quad u_{11} = \frac{k}{\rho\sigma} A \frac{\cosh k(z + h)}{\cosh k(\zeta + h)} \quad (2-12)$$

$$\text{where } \sigma = \omega - kU \quad (2-13)$$

(c) gives:

$$m = 0 \quad w_{10} = 0 \quad (2-14)$$

$$m = 1 \quad w_{11} = -\frac{ik}{\rho\sigma} A \frac{\sinh k(z+h)}{\cosh k(\zeta+h)} \quad (2-15)$$

(e) gives:

$$m = 0 \quad 0 = 0$$

$$m = 1 \quad \eta_{11} = \frac{k}{\rho\sigma^2} A \tanh k(\zeta+h) \quad (2-16)$$

(f) gives:

$$m = 0 \quad 0 = 0$$

$$m = 1 \quad \sigma^2 = gk \tanh k(\zeta+h) \quad (2-17)$$

$$\text{or } (\omega - kU)^2 = gk \tanh k(\zeta+h)$$

It allows us to write  $\eta_{11} = \frac{A}{\rho g}$

$O(\varepsilon^2)$

(a) and (d) give:

$$m = 0 \quad p_{20} = -\frac{k^2}{\rho\sigma^2} \frac{\cosh 2k(z+h)}{\cosh k(\zeta+h)} \quad |A|^2 + P_{20}(x_2, t_2, \tau) \quad (2-18)$$

where  $P_{20}$  is a new arbitrary function.

$$m = 1 \quad p_{21} = D(x_2, t_2, \tau) \frac{\cosh k(z+h)}{\cosh k(\zeta+h)} - i \frac{A_\tau}{Cg \cosh k(\zeta+h)}$$

$$\left\{ (z+h) \sinh k(z+h) - (\zeta+h) \tanh k(\zeta+h) \cosh k(z+h) \right\} \quad (2-19)$$

where  $D$  is a new arbitrary function.



$$m = 2 \quad p_{22} = F(x_2, t_2, \tau) \frac{\cosh 2k(z+h)}{\cosh 2k(\zeta+h)} - \frac{k^2 A^2}{2\rho\sigma^2 \cosh^2 k(\zeta+h)} \quad (2-20)$$

where F is a new arbitrary function.

(b) gives:

$$m = 0 \quad \frac{\partial u_{10}}{\partial \tau} = \frac{1}{\rho(Cg - U)} \frac{\partial p_{10}}{\partial \tau} \quad (2-21)$$

$$m = 1 \quad u_{21} = \frac{k}{\rho\sigma} D \frac{\cosh k(z+h)}{\cosh k(\zeta+h)} - \frac{ikA}{\rho\sigma(g \cosh k(\zeta+h)) \tau}$$

$$\left\{ (z+h) \sinh k(z+h) + \cosh k(z+h) \left[ -(\zeta+h) \tanh k(\zeta+h) + \frac{1}{k} + \frac{U - Cg}{\sigma} \right] \right\} \quad (2-22)$$

$$m = 2 \quad u_{22} = \frac{k}{\rho\sigma} F \frac{\cosh 2k(z+h)}{\cosh 2k(\zeta+h)} \quad (2-23)$$

(c) gives:

$$m = 0 \quad w_{20} = - \frac{(z+h)}{Cg} \frac{\partial u_{10}}{\partial \tau} \quad (2-24)$$

$$m = 1 \quad w_{21} = - \frac{ik}{\rho\sigma} D \frac{\sinh k(z+h)}{\cosh k(\zeta+h)} + \frac{A}{\rho\sigma Cg \cosh k(\zeta+h) \tau}$$

$$\left\{ -k(z+h) \cosh k(z+h) + \sinh k(z+h) \left[ k(\zeta+h) \tanh k(\zeta+h) - 1 + k \frac{Cg - U}{\sigma} \right] \right\} \quad (2-25)$$

$$m = 2 \quad w_{22} = - \frac{ik}{\rho\sigma} F \frac{\sinh 2k(z+h)}{\cosh 2k(\zeta+h)} \quad (2-26)$$

(e) gives:

$$m = 0 \quad \frac{\partial \eta_{10}}{\partial \tau} = - \frac{Cg}{Cg - U} w_{20} \quad (2-27)$$

$$m = 1 \quad \eta_{21} = \frac{D}{\rho g} + i \frac{A_\tau}{\rho \sigma^2 C_g} \left\{ -k(\zeta + h) + \tanh k(\zeta + h) \left[ k(\zeta + h) \right. \right. \\ \left. \left. \tanh k(\zeta + h) - 1 + 2k \frac{C_g - U}{\sigma} \right] \right\} \quad (2-28)$$

$$m = 2 \quad \eta_{22} = \frac{k}{2\rho\sigma^2} F \tanh 2k(\zeta + h) + \frac{A^2 k^2}{\rho^2 g \sigma^2} \quad (2-29)$$

(f) gives:

$$m = 0 \quad \frac{\partial u_{10}}{\partial \tau} = 0 \quad (2-30)$$

$$m = 1 \quad C_g = U + \frac{1}{2} C_p \left\{ 1 + \frac{2k(\zeta + h)}{\sinh 2k(\zeta + h)} \right\} \text{ where } C_p = \frac{\sigma}{k} \quad (2-31)$$

where  $C_p$  and  $C_g$  denote the phase and the group velocity in the presence of a current

$$m = 2 \quad F = \frac{3k^2 \cosh 2k(\zeta + h)}{2\rho\sigma^2 \cosh^2 k(\zeta + h) \sinh^2 k(\zeta + h)} A^2 \quad (2-32)$$

Let us pause here to see the implications of the condition  $\frac{\partial u_{10}}{\partial \tau} = 0$ ;

it implies:

- $w_{20} = 0$  (cf (2-24))
- $\frac{\partial p_{10}}{\partial \tau} = 0$  (cf (2-21))
- $\frac{\partial \eta_{10}}{\partial \tau} = 0$  (cf (2-27))

It follows that  $u_{10} = u_{10}(x_2, t_2)$ ,  $p_{10} = p_{10}(x_2, t_2)$  and  $\eta_{10} = \eta_{10}(x_2, t_2)$  where  $u_{10}$ ,  $p_{10}$  and  $\eta_{10}$  are three arbitrary functions corresponding to a current of order  $\varepsilon$ . By assuming zero values far upstream  $\tau \sim -\infty$ , we take these arbitrary functions to be zero.

$$\left\{ \begin{array}{l} u_{10} = 0 \\ p_{10} = 0 \\ \eta_{10} = 0 \\ w_{20} = 0 \end{array} \right. \quad (2-34)$$

At this point we have only 3 arbitrary functions:  $A$ ,  $P_{20}$  and  $D$ . Our principal interest is obviously to find  $A$ . At order  $O(\epsilon^3)$  we look for the equation governing  $A$ ,  $P_{20}$  and eventually  $D$ . It is relatively easy to guess that these equations will be given by the dynamic boundary condition for  $m = 0, 1$ . So we need only to compute the third order terms which appear in these equations.

(a) and (d) we need only  $p_{31}$

$$m = 1 \quad p_{31} = G(x, \tau, t) \frac{\cosh k(z+h)}{\cosh k(\zeta+h)} - iD_{\tau} (z+h) \frac{\sinh k(z+h)}{Cg \cosh k(\zeta+h)} \quad (2-35)$$

$$\begin{aligned} & -iA_{x_2} (z+h) \frac{\sinh k(z+h)}{\cosh k(\zeta+h)} - |A|^2 A \frac{3}{2} \cosh 3k(z+h) \frac{k^4}{\rho^2 \sigma^4 \cosh^3 k(\zeta+h) \sinh^2 k(\zeta+h)} \\ & -A_{\tau\tau} \left\{ \frac{(z+h)^2 \cosh k(z+h)}{2Cg^2 \cosh k(\zeta+h)} - \frac{(z+h) \sinh k(z+h)(\zeta+h) \tanh k(h+\zeta)}{Cg^2 \cosh k(\zeta+h)} \right\} \\ & -iA \frac{1}{\cosh k(\zeta+h)} \left\{ \frac{(z+h)^2 \cosh k(z+h)}{2} \frac{\partial k}{\partial x_2} + \right. \\ & \left. + (z+h) \cosh k(z+h) \frac{\partial}{\partial x_2} (\zeta+h) + (z+h) \sinh k(z+h) \right. \\ & \left. \left[ \frac{2k}{\sigma} \frac{\partial U}{\partial x_2} - \tanh k(\zeta+h) \frac{\partial k(\zeta+h)}{\partial x_2} \right] \right\} \quad (2-36) \end{aligned}$$

(b) we need only  $u_{20}$

$$m = 0 \quad \frac{\partial u_{20}}{\partial \tau} = \frac{1}{\rho(Cg - U)} \frac{\partial P_{20}}{\partial \tau} \quad \text{which implies } u_{20} = \frac{1}{\rho(Cg - U)} P_{20} + F(x_2, t_2) \quad (2-37)$$

where  $F(x_2, t_2)$  is an arbitrary function which must be real since  $u_{20}$  and  $P_{20}$  are real.

(c) we need only  $w_{30}$  and  $w_{31}$

$$m = 0 \quad w_{30} = -\frac{1}{Cg} (z + h) \frac{\partial u_{20}}{\partial \tau} = -\frac{(z + h)}{\rho Cg (Cg - U)} \frac{\partial P_{20}}{\partial \tau}$$

to get  $w_{31}$  it is easier to use directly the z-momentum equation (1-7) at  $O(\epsilon^3)$   $m = 1$

$$w_{31} = -\frac{ik \sinh k(z + h)}{\rho \sigma \cosh k(\zeta + h)} - iD_\tau \left\{ \frac{k(z + h) \cosh k(z + h) + \sinh k(z + h)}{\rho \sigma Cg \cosh k(\zeta + h)} \right.$$

$$\left. - \frac{(U - Cg) k \sinh k(\zeta + h)}{Cg \rho \sigma \cosh k(\zeta + h)} \right\} + i \frac{A_{\tau\tau}}{\rho Cg^2 \sigma \cosh k(\zeta + h)}$$

$$\left\{ (z + h) \cosh k(z + h) + \frac{k(z + h)^2}{2} \sinh k(z + h) - \right.$$

$$\left. (\zeta + h) \tanh k(\zeta + h) \left[ k(z + h) \cosh k(z + h) + \sinh k(z + h) \right] \right.$$

$$\left. - (U - Cg) \frac{k}{\sigma} \left[ - (z + h) \cosh k(z + h) + \sinh k(z + h) \right] \right.$$

$$\left. \left[ k(\zeta + h) \tanh k(\zeta + h) - 1 - k \frac{U - Cg}{\sigma} \right] \right\} - \frac{A_{x_2}}{\cosh k(\zeta + h) \rho \sigma}$$

$$\left[ k(z + h) \cosh k(z + h) + \sinh k(z + h) + \frac{k}{\sigma} U \sinh k(z + h) \right]$$

$$- A_{t_2} \frac{k}{\rho \sigma^2} \frac{\sinh k(z + h)}{\cosh k(\zeta + h)} - \frac{A}{\rho \sigma} \left[ (z + h) \frac{\cosh k(z + h)}{\cosh k(\zeta + h)} k_{x_2} \right.$$

$$\left. + \frac{k k_{x_2}}{2 \cosh k(\zeta + h)} (z + h)^2 \sinh k(z + h) + \frac{k h_{x_2}}{\cosh k(\zeta + h)} \right]$$

$$\left\{ k(z + h) \sinh k(z + h) + \cosh k(z + h) \right\} + \left\{ k(z + h) \cosh k(z + h) \right.$$

$$\left. + \sinh k(z + h) \right\} \left\{ \frac{2kU}{\sigma \cosh k(\zeta + h)} k_{x_2} - (kh)_{x_2} \frac{\sinh k(z + h)}{\cosh k(\zeta + h)} \right\}$$

$$\begin{aligned}
& + \frac{k}{\sigma} \left( \frac{\sinh k(z+h)}{\cosh k(\zeta+h)} \right)_{t_2} - \frac{k}{\sigma} U_{x_2} \frac{\sinh k(z+h)}{\cosh k(\zeta+h)} - (z+h) U_{x_2} \frac{h^2 \cosh k(z+h)}{\sigma \cosh k(\zeta+h)} \\
& - h_{x_2} \frac{Uk^2}{\sigma} + \frac{kU}{\sigma} \left\{ \frac{k_{x_2} (z+h) + kh_{x_2}}{\cosh k(\zeta+h)} - (kh)_{x_2} \frac{\sinh k(z+h) \sinh k(\zeta+h)}{\cosh^2 k(\zeta+h)} \right\} \\
& + \frac{ik^2}{\rho^2 \sigma^2 (U - Cg)} \frac{\sinh k(z+h)}{\cosh k(\zeta+h)} P_{20} A - i |A|^2 A \frac{3k^5}{\rho^3 \sigma^5} \frac{1}{\cosh^3 k(\zeta+h) \sinh^2 k(\zeta+h)} \\
& \left\{ \frac{3}{2} \cosh k(z+h) \sinh 2k(z+h) + \frac{3}{2} \sinh 3k(z+h) + \sinh k(z+h) \right. \\
& \left. \cosh 2k(z+h) \right\}
\end{aligned}$$

(e) we need only  $\eta_{20}$

$$m = 0 \quad (u - Cg) \frac{\partial \eta_{20}}{\partial \tau} = \frac{\zeta + h}{\rho(U - Cg)} P_{20} - \frac{2k}{\rho^2 \sigma} |A|_{\tau}^2 \quad (2-39)$$

which implies

$$\eta_{20} = \frac{(\zeta + h)}{\rho(Cg - U)^2} P_{20} + \frac{2k}{\rho^2 \sigma (Cg - U)} |A|^2 + F_2(x_2, t_2)$$

where  $F(x_2, t_2)$  is an arbitrary function which must be real since  $\eta_{20}$ ,

$P_{20}$  are real.

(f) It is only necessary to write the kinematic condition for  $m = 0, 1$ . This will give us 2 equations governing the evolution of  $P_{20}$  and  $A$ . It is important to remark that  $D$  and  $G$  which are still unknown do not appear in these equations.

$$\begin{aligned}
m = 0 \quad \frac{\partial P_{20}}{\partial \tau} \left\{ 1 - \frac{(Cg - U)^2}{g(\zeta + h)} \right\} &= - \frac{k^2}{\rho \sigma} \frac{Cg(Cg - U)}{g(\zeta + h)} \\
\left\{ 2 \frac{Cp}{Cg} + \frac{Cg - U}{Cg} (1 - \beta^2) \right\} |A|_{\tau}^2 &
\end{aligned}$$

where  $\beta = \tanh k(\zeta + h)$ . This equation can be integrated once:

$$P_{20} \left\{ 1 - \frac{(Cg - U)^2}{g(\zeta + h)} \right\} = \frac{k^2}{\rho\sigma} \frac{Cg(Cg - U)}{g(\zeta + h)} - 2 \frac{C}{Cg} + \frac{Cg - U}{Cg} (1 - \beta^2) \quad (2-40)$$

$$|A|^2 + F_3(x_2, t_2)$$

where  $F_3(x_2, t_2)$  is an arbitrary function which must be real since  $P_{20}$  is real.

$m = 1$  At this step we obtain the governing equation for  $A$ :

$$y_1 A + A_{t_2} + Cg A_{x_2} + iy_2 A + iy_3 |A|^2 A + iy_5 P_{20} A + iy_6 F_1 A + iy_7 F_2 A = 0 \quad (2-41)$$

where all the  $y_i$  are real functions of  $x_2$  and  $t_2$ . We will give their expression later. By using the previous expression of  $P_{20}$  the equation becomes:

$$y_1 A + A_{t_2} + Cg A_{x_2} + iy_2 A + iy_3 |A|^2 A + iQA = 0 \quad (2-42)$$

where  $Q(x_2, t_2) = y_6 F_1 + y_7 F_2 + y_8 F_3$  is a real function depending on the unknown function  $F_i$   $i = 1, 2, 3$ .

• The function  $Q$  vanishes for a wave packet where  $A$  and  $P_{20}$  tend to zero as  $\tau \rightarrow \pm \infty$  in this case equation (2-42) becomes:

$$y_1 A + A_{t_2} + Cg A_{x_2} + iy_2 A_{\tau\tau} + iy_3 |A| A = 0 \quad (2-43)$$

• If  $Q \neq 0$  but if it does not depend on  $t_2$  (this is the case if the current is stationary, see 3-2) we write  $A = B \exp - i \int^{x_2} Q(u) du$ . As  $Q$  is real  $|A| = |B|$ ; once we know  $B$  we know the envelope of the waves. It is obvious that the equation for  $B$  is still (2-43).

Let us now give the expressions of the coefficients  $y_1(x_2, t_2)$ ,  $y_2(x_2, t_2)$ ,  $y_3(x_2, t_2)$  which can be put, after lengthy algebra, in the following form:

$$\begin{aligned}
y_1 &= -\frac{1}{2\sigma} \frac{\partial \sigma}{\partial t_2} + \frac{\sigma}{2} \frac{\partial Cg/\sigma}{\partial x_2} \\
y_2 &= \frac{1}{2\sigma} \frac{(Cg - U)^2}{Cg^2} \left\{ 1 - \frac{g(\zeta + h)}{(Cg - U)^2} (1 - \beta^2) (1 - \beta k (\zeta + h)) \right\} \\
y_3 &= \frac{k^4}{4\rho^2 \sigma^3 \beta^2} \left\{ 9 - 10\beta^2 + 9\beta^4 - 2\beta^2 \frac{(Cg - U)^2}{g(\zeta + h) - (Cg - U)^2} \right. \\
&\quad \left. \left[ 4 \frac{C_p}{Cg - U} + 4 \frac{C_p (1 - \beta^2)}{Cg - U} + \frac{g(\zeta + h)}{(Cg - U)^2} (1 - \beta^2)^2 \right] \right\}
\end{aligned} \tag{2-44}$$

2.3. Concluding remarks on the equations.

(a) The general procedure to solve the problem is as follows:

- First step: given  $h(x_2)$  solve the Airy's equations to find the current:

$$U(x_2, t_2) \quad \zeta(x_2, t_2)$$

- Second step: we must solve for  $k(x_2, t_2)$  and  $\omega(x_2, t_2)$ . For this we use:

i. Law of conservation of waves:

$$\frac{\partial \omega}{\partial x_2} + \frac{\partial k}{\partial t_2} = 0$$

ii. Dispersion relation:

$$(\omega - kU)^2 = gk \tanh k(\zeta + h)$$

These equations are solved with the boundary condition:

$$\omega \rightarrow \omega_0 \text{ as } x_2 \rightarrow -\infty$$

- Third step:

Once  $U$ ,  $\zeta$ ,  $\omega$  and  $k$  are known then all the coefficients of equation

(2-43) are known. We then solve this equation with proper boundary conditions.

(b) One important special case corresponds to a stationary solution to the Airy's equations. In this case  $U(x_2)$  and  $\zeta(x_2)$ , and we can take  $k(x_2)$ ,  $\omega(x_2)$  to be also stationary. The law of conservation of crests then gives  $\frac{d\omega}{dx_2} = 0$  implying that  $\omega = \text{constant} = \omega_0$ , then  $k(x_2)$  is simply given by the equation

$$(\omega_0 - kU)^2 = gk \tanh k(\zeta + h)$$

(c) The linearized limit: the results of linear theory for a bottom varying on the scale  $O(\frac{1}{\mu})$  are well known; the equations are:

i. Without current:  $U \equiv 0$

$$\frac{\partial E}{\partial t_1} + \frac{\partial}{\partial x_1} (CgE) = 0 \quad \text{where } E = |A|^2 \quad t_1 = \mu t \quad x_1 = \mu x$$

This is the law of conservation of energy.

By coming back to the formulation of the problem it is easy to see that the linear limit is obtained by taking  $A = A(x_2)$  and ignoring the nonlinear terms. If we ignore the terms with  $A_{\tau\tau}$  and  $|A|^2 A$  equation (2-43) becomes:

$$\frac{\partial A}{\partial t_2} + Cg \frac{\partial A}{\partial x_2} + \frac{1}{2Cg} \frac{dCg}{dx_2} A = 0 \quad (2-45)$$

(As  $U = 0$  we are obviously in the previous case (b)  $k = k(x_2)$  and  $\omega = \omega_0$ .)

Let us take (2-45)\* x A + (2-45) x A\* it gives

$$\frac{\partial |A|^2}{\partial t_2} + \frac{\partial}{\partial x_2} (Cg |A|^2) = 0 \quad \text{which is the law of conservation of energy.}$$

ii. With current  $U \neq 0$

In presence of a current the law of conservation of energy is replaced by the law of conservation of wave action (cf for instance reference [12])



$$\frac{\partial E/\sigma}{\partial t_1} + \frac{\partial}{\partial x_1} (Cg E/\sigma) = 0$$

Once more if we neglect the  $A_{\tau\tau}$  and  $|A|^2$  A terms in equation (2-43) it gives

$$\frac{\partial A}{\partial t_2} + Cg \frac{\partial A}{\partial x_2} - \frac{1}{2\sigma} \frac{\partial \sigma}{\partial t_2} A + \frac{\sigma}{2} \frac{\partial Cg/\sigma}{\partial x_2} A = 0$$

or

$$\frac{1}{\sigma} \frac{\partial A}{\partial t_2} - \frac{1}{2\sigma^2} \frac{\partial \sigma}{\partial t_2} A + \frac{Cg}{\sigma} \frac{\partial A}{\partial x_2} + \frac{1}{2} \frac{\partial Cg/\sigma}{\partial x_2} A = 0 \quad (2-46)$$

if we take (2-46)\* x A + (2-46) x A\* it gives

$$\frac{\partial |A|^2/\sigma}{\partial t_2} + \frac{\partial (Cg |A|^2/\sigma)}{\partial x_2} = 0$$

which is the conservation of wave action.

### 3. Evolution Equations for Special Cases.

#### 3.1. Case without current.

This case has already been studied in reference [5]. As indicated in § 2.3(b) we can take  $k = k(x_2)$   $w = w_0$ . Let  $U = 0$   $\zeta = 0$ ; equation (2-43) takes the form:

$$y_1'(x_2) A + \frac{1}{Cg(x_2)} A_{t_2} + A_{x_2} + iy_2'(x_2) A_{\tau\tau} + iy_3(x_2) |A|^2 A = 0 \quad (3-1a)$$

where the coefficients  $y_1'$ ,  $y_2'$ ,  $y_3'$  which depends only of  $x_2$  are:

$$y_1'(x_2) = (kh)_{x_2} \frac{(1 - \beta^2)(1 - \beta kh)}{\beta + kh(1 - \beta^2)} = \frac{1}{2Cg} \frac{dCg}{dx_2} \quad (3-1b)$$

$$y_2'(x_2) = -\frac{1}{2\omega Cg} \left\{ 1 - \frac{gh}{Cg^2} (1 - \beta kh) \right\} \quad (3-1c)$$

$$y_3'(x_2) = \frac{k^4}{Cg^4 \rho^2 \sigma^3 \beta^2} \left\{ 9 - 10\beta^2 + 9\beta^4 - \frac{2\beta^2 Cg^2}{gh - Cg^2} \left[ 4 \left( \frac{C_p}{Cg} \right)^2 + 4 \frac{C_p}{Cg} (1 - \beta^2) + \frac{gh}{Cg^2} (1 - \beta^2)^2 \right] \right\} \quad (3-1d)$$

which agree with reference [5] where the case  $A_{t_2} = 0$  is studied.

If furthermore the depth is constant  $y_1(x_2) = 0$  and the equation reduces to the cubic Schrödinger equation with constant coefficients with an additional term due to the fact that variations in  $t_2$  are allowed.

#### 3.2. Case with stationary current.

Let us first recall the Airy's equations governing the evolution of the current.

$$\begin{cases} \frac{\partial \zeta}{\partial t_2} + \frac{\partial}{\partial x_2} [(\zeta + h)U] = 0 \\ \frac{\partial U}{\partial t_2} + U \frac{\partial U}{\partial x_2} + g \frac{\partial \zeta}{\partial x_2} = 0 \end{cases}$$

In the general case the solution of these equations is not stationary. This is certainly true if  $h$  is constant since Airy's equations with constant depth do not admit stationary solutions (except the trivial solution constant in  $x_2$  and  $t_2$ ). In this case the problem is very complicated since  $k$  and  $\omega$  are functions of  $x_2$  and  $t_2$  and the coefficients of the equation governing  $A$  depends on  $x_2$  and  $t_2$ , we must first solve for  $\omega$  and  $k$  and then look for a solution function of the three independent variables. This case will not be pursued here.

Mathematically it is particularly interesting to study the case of a stationary current since in this case, as indicated in § 2.3(b) we can take  $k = k(x_2)$   $\omega = \omega_0 = \text{constant}$ ; the coefficients of the equation for  $A$  are also independent of  $t_2$ . So if the boundary conditions for  $A$  do not involve  $t_2$  we can reduce the problem to a 2-D one, ignoring the variable  $t_2$ .

Physically this limitation allows us to study the effect of variation of depth on the propagation of a wave packet in the presence of a strong current once the stationary state for the current is obtained.

Let us examine the possibility of a stationary current.

i. If  $h = \text{constant}$  the current is stationary only if  $U$  and  $\zeta$  are constant everywhere. This can easily be shown by taking  $\frac{\partial}{\partial t_2} = \frac{dh}{dx_2} = 0$ . In the Airy's equations the coefficients of the equation for  $A$  are then

$$\left\{ \begin{array}{l} y_1 = 0 \\ y_2 = \text{constant} \\ y_3 = \text{constant} \end{array} \right. \quad (3-2)$$

$$\text{and } A \text{ satisfies } A_{x_2} + iy_2 A_{\tau\tau} + iy_3 |A|^2 A = 0 \quad (3-3)$$

for the expression of  $y_2$  and  $y_3$  see (2.44).

Equation (3.3) could have been obtained by writing the equation for  $A$ , for constant depth and without current, in a moving frame.

ii. If  $h$  is not constant then there exist certain conditions on the depth profile for the existence of a stationary solution to the Airy's equation. If  $U$  and  $\zeta$  are only functions of  $x_2$  the Airy's equations become:

$$(1) \quad \frac{d}{dx_2} [(\zeta + h)U] = 0$$

which implies  $(\zeta + h)U = \text{constant} = \phi_1 = \text{flux at } -\infty = U_1 H_1$  where  $U_1$  is the velocity and  $H_1$  the depth as  $x_2 \rightarrow -\infty$ . The origin of the  $z$ -axis is chosen such that  $\zeta(x_2) \rightarrow 0$  as  $x_2 \rightarrow -\infty$ .

$$(2) \quad U \frac{dU}{dx_2} + g \frac{d\zeta}{dx_2} = 0$$

Equation (1) gives us  $U = \frac{U_1 H_1}{(\zeta + h)}$ . If we substitute this expression in

(2) we get:

$$-\frac{U_1^2 H_1^2}{(\zeta + h)^3} \frac{d(\zeta + h)}{dx_2} + g \frac{d\zeta}{dx_2} = 0$$

which gives by integration

$$\frac{U_1^2 H_1^2}{2} \frac{1}{(\zeta + h)^2} + g\zeta = \text{constant}$$

Since as  $x_2 \rightarrow -\infty$   $h \rightarrow H_1$   $\zeta \rightarrow 0$  the constant of integration is  $\frac{U_1^2}{2}$ .

We then find the following equation for  $\zeta$

$$U_1^2 H_1^2 + 2g \zeta (\zeta + h)^2 - U_1^2 (\zeta + h)^2 = 0 \quad (3-4)$$

or

$$\left(\frac{\zeta + h}{H_1}\right)^3 - \left(\frac{h}{H_1} + \frac{U_1^2}{2gH_1}\right) \left(\frac{\zeta + h}{H_1}\right)^2 + \frac{U_1^2}{2gH_1} = 0 \quad \text{where } h = h(x_2)$$

$\frac{\zeta + h}{H_1}$  is, if it exists the root of this cubic equation such that  $\zeta(x_2)$

is continuous and vanishes as  $x_2 \rightarrow -\infty$

If we use the following dimensionless variables

$$L = H_1 L' \quad (H_1 \text{ is the typical length scale})$$

$$U = \sqrt{gH_1} U' \quad (\sqrt{gH_1} \text{ is the typical velocity scale})$$

then:

$$\left\{ \begin{array}{l} \frac{\zeta + h}{H_1} = X = \text{dimensionless total depth} \\ \frac{h}{H_1} = h' = \text{dimensionless depth without current} \\ \frac{U_1}{\sqrt{gH_1}} = U_1' = \text{dimensionless velocity at } x = -\infty \end{array} \right. \quad (3-5)$$

Dropping primes, the equation for the unknown  $X(x_2)$  is:

$$X^3 - (h(x_2) + \frac{U_1^2}{2}) X^2 + \frac{U_1^2}{2} = 0 \quad (3-6)$$

It is straight forward but tedious to study the possibility of a solution  $X$  which must be continuous and approaches 1 as  $x_2 \rightarrow -\infty$ .

Leaving the details to Appendix A let us give here only the results:

if  $U_1^2 > 3\sqrt{3}$  then for any  $h > 0$  we have one solution

if  $U_1^2 < 3\sqrt{3}$  and  $U_1^2 \neq 1$

i. if  $h \geq hc = 3 \sqrt{\frac{U_1^2}{8}} - \frac{U_1^2}{2}$  ( $hc < 1$ ) there is one

solution.

ii. if  $h < hc < 1$  there is no solution

if  $U_1^2 = 1$

i. if  $h > hc = 1$  there are two solutions

ii. if  $h < hc = 1$  there is no solution

The important fact is that, once  $U_1$  is given, a stationary current is possible only if the depth profile satisfies everywhere  $h > hc$ .

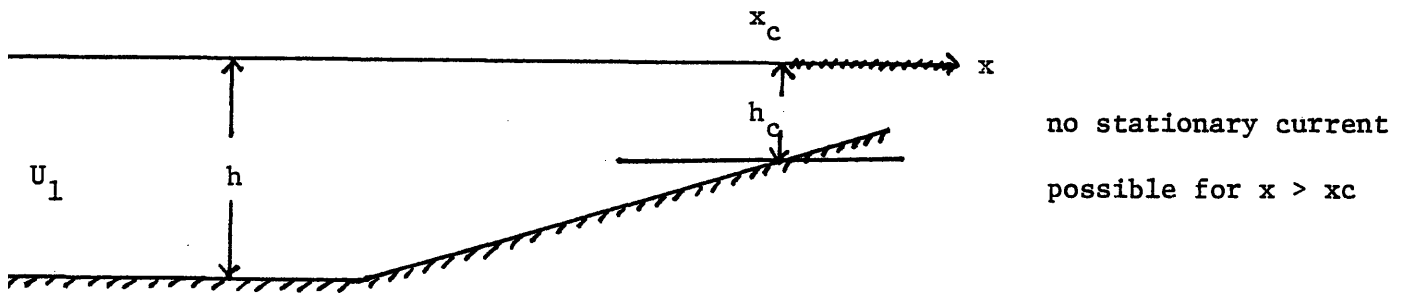

Fig. (1)

Values of  $hc(U_1)$  are plotted on Fig.(3)

The problem we want to study can be summarized on the following figure:

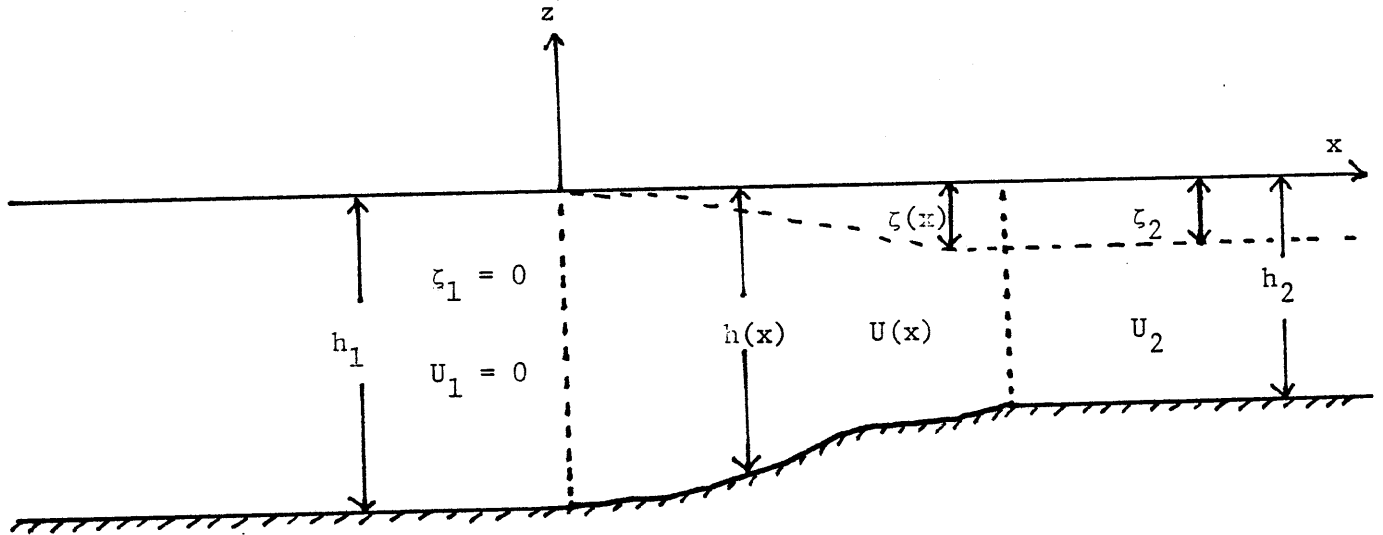

Fig. (2)

This is the only problem we will now consider.

Assuming the boundary conditions for A to be independent of  $t_2$  let us now give the dimensionless equation satisfied by  $A(x_2, \tau)$ .

- The length scale is  $H_1$
- The time scale is  $\sqrt{\frac{H_1}{g}}$  It means in particular that the dispersion

relation can be written in dimensionless variables:

$$(2\pi/T - kU)^2 = k \tanh(kX)$$

- The dimensionless amplitude is  $A' = \frac{A}{\rho g H_1}$  (A has the dimension of a pressure)

- The velocity scale is  $\sqrt{gH_1}$

Then in dimensionless variables the equation for  $A'$  is (primes will be dropped):

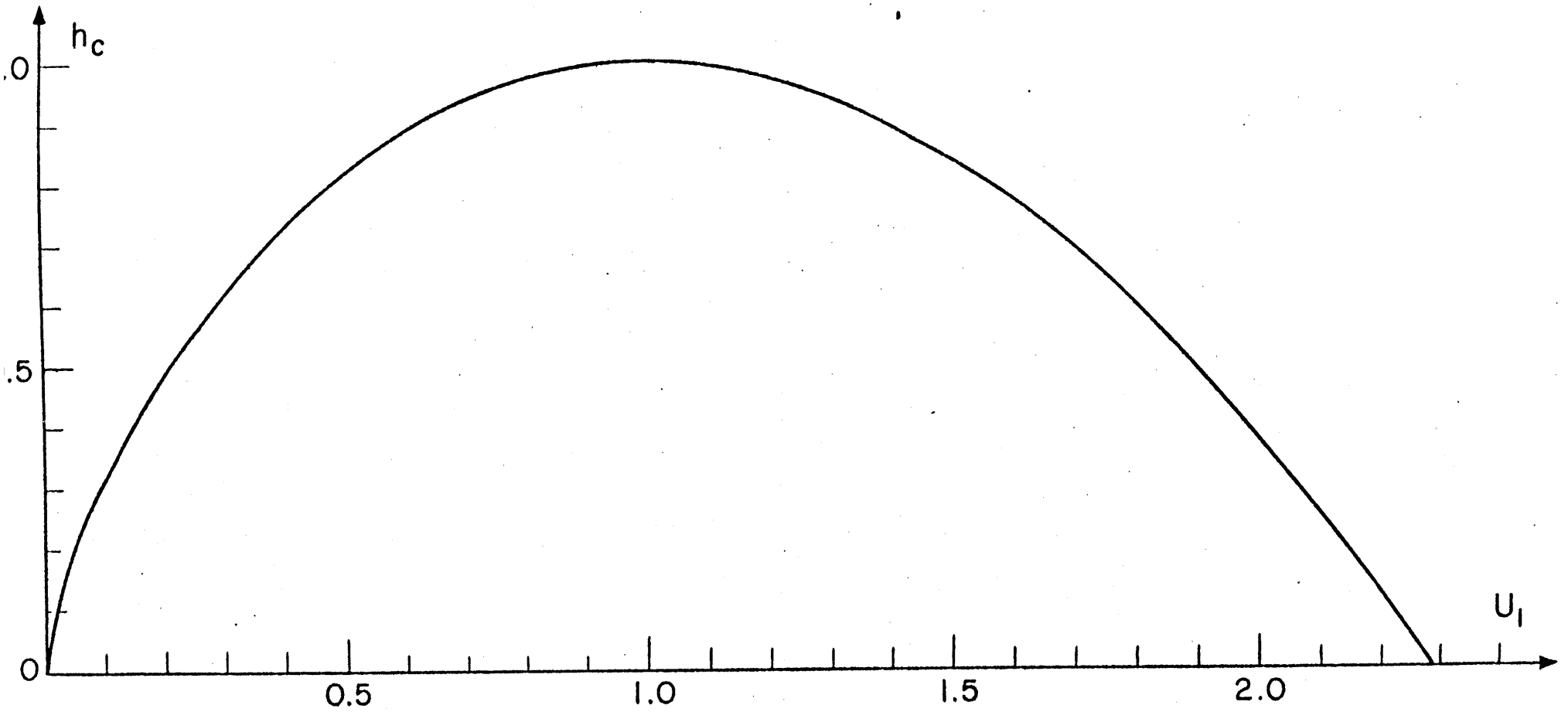

Figure 3. Critical depth as a function of the current at  $-\infty$



$$y_1(x_2)A + A_{x_2} + iy_2(x_2) A_{\tau\tau} + iy_3(x_2) |A|^2 A = 0 \quad (3-7a)$$

where the dimensionless coefficients are

$$y_1(x_2) = \frac{1}{2(Cg/\sigma)} \frac{dCg/\sigma}{dx_2} \quad (3-7b)$$

$$y_2(x_2) = \frac{1}{2\sigma Cg} \frac{(Cg - U)^2}{Cg^2} \left\{ 1 - \frac{X}{(Cg - U)^2} (1 - \beta^2) (1 - \beta kX) \right\} \quad (3-7c)$$

$$y_3(x_2) = \frac{k}{4CgC_p \beta^2} \left\{ 9 - 10\beta^2 + 9\beta^4 - 2 \frac{\beta^2 (Cg - U)^2}{X - (Cg - U)^2} \right. \\ \left. \left[ 4 \frac{C_p}{Cg - U} + 4 \frac{C_p}{Cg - U} (1 - \beta^2) + \frac{X}{(Cg - U)^2} (1 - \beta^2)^2 \right] \right\} \quad (3-7d)$$

where all the variables are dimensionless,  $X = \frac{\zeta + h}{H_1}$

To solve the problem for  $A(x_2, \tau)$  we must prescribe boundary conditions. It is known (cf part II) that for the cubic Schrödinger equation with constant coefficients  $u_t + i \nu u_{xx} + i \nu |u|^2 u = 0$  ( $u(x, t)$ ) the problem is well posed if we specify:

$$\left\{ \begin{array}{l} u(x, t = 0) = f(x) \\ \text{boundary conditions as } x \rightarrow \pm \infty \end{array} \right.$$

For instance  $u$  and all its derivatives vanish as  $t \rightarrow \pm \infty$ . So the boundary conditions we choose are obviously

$$\left\{ \begin{array}{l} A(0, \tau) = f(\tau) \\ \text{+ boundary conditions as } \tau \rightarrow \pm \infty \end{array} \right.$$

Since  $x_2 = \epsilon^2 x$  and  $\tau = \epsilon \left( \int_0^x \frac{dx}{Cg(x_2)} - t \right)$  it follows that  $\tau = -\epsilon t$  when  $x = 0$ . The boundary condition at  $x_2 = 0$  is simply giving  $A$  as a function, (slowly varying) of time.

PART II: ANALYTICAL STUDY

In this part we only study a problem which does not involve  $t_2$  (stationary current and boundary conditions independent of  $t_2$ ). The initial value problem is then:

$$\begin{cases} y_1(x_2)A + A_{x_2} + iy_2(x_2) A_{\tau\tau} + iy_3(x_2) |A|^2 A = 0 \\ A(0,\tau) = f(\tau) \text{ given} \\ + \text{ conditions as } \tau \rightarrow \pm \infty \end{cases} \quad (0-1)$$

1. Study of the Equation when the Coefficients are Constant.

1.1. Generalities.

When the depth is constant the coefficients  $y_2, y_3$  are constant and  $y_1 = 0$ . The equation we have to solve is the cubic Schrödinger equation with constant coefficient. Problem (0-1) becomes:

$$\begin{cases} A_{x_2} + iy_1 A_{\tau\tau} + iy_2 |A|^2 A = 0 \\ A(0,\tau) = f(\tau) \\ + \text{ condition as } \tau \rightarrow \pm \infty \end{cases} \quad (1-1)$$

This cubic Schrödinger equation which appears in many other contexts involving nonlinear dispersive waves has been studied a lot since more than 10 years. It has been shown that the method found by Gardner and Miura (1967) reference [6] to solve the K.d.V equation  $u_t - 6uu_x + u_{xxx} = 0$ , governing the evolution of nonlinear dispersive unidirectional waves in shallow water, can be extended to this equation. This result, due to Zakharov and Shabat was first found for the case  $y_1 y_2 > 0$  (1972) reference [28] then for the case  $y_1 y_2 < 0$  (1973) reference [29] with different boundary conditions as  $v \rightarrow \pm \infty$  for the two cases.

The method used is the so-called Inverse Scattering method, whose

domain of application includes the modified K.d.V equation ( $u_t + 6u^2u_x + u_{xxx} = 0$ ) the sine Gordon equation ( $u_{xt} = \sin u$ ) the sinh Gordon equation ( $u_{xt} = \sinh u$ ) and other non linear P.D.E. This method essentially reduces the nonlinear problem to a linear one which is still non trivial but which can be studied in the limit  $\tau \rightarrow \infty$   $x_2 \rightarrow \infty$   $x_2 = c\tau$ .

For a very good review of this method, in a rather general framework, see for instance Ablowitz, et al. (1974) reference [1].

Here we will recall some well known special solutions to the cubic Schrödinger equation (to be called C.S.E. for brevity). In Appendix B and C we will give the details of the inverse scattering method as it applies to this equation.

1.2. Some special solutions of the cubic Schrödinger equation. The form of the special solutions of the C.S.E. depends on the sign of  $y_1y_2$ . If there is no current it is a classical result that:

- if  $kh > 1.363$   $y_1y_2 > 0$  (deep water)
- if  $kh < 1.363$   $y_1y_2 < 0$  (shallow water)

The following exact solutions of the C.S.E. can be found in references [28], [29], [7], [14] and [19].

- (a)  $y_1y_2 > 0$  We take without loss of generality  $y_1 > 0$   $y_2 > 0$
- i. Stoke's waves:  $A = A(x_2) = a_0 \exp - i(a_0^2 y_2 x_2 + \phi)$
- (1-2)

It is well known that this solution is linearly unstable to long waves disturbances (Benjamin Feir instability reference [2]).

- ii. Cnoidal waves:

$$A(x_2, \tau) = a_0 \operatorname{cn} \left\{ a_0 \sqrt{\frac{y_2}{2y_1}} \frac{\tau}{m} \right\} \exp i(\omega_2 x_2) \quad (1-3)$$

where  $m = 2 + \frac{2}{y_2} \frac{\omega_2}{a_0^2}$  and  $c_n$  is a Jacobian elliptic function.

iii. Soliton and multisoliton:

• When  $m \rightarrow 1$  the cnoidal wave becomes:

$$A(x_2, \tau) = a \operatorname{sech} \left( a \sqrt{\frac{y_2}{2y_1}} \tau \right) \exp \left( \frac{ia^2 y_2}{2} x_2 \right) \text{ which is a particular}$$

case of the general soliton solution.

$$A(x_2, \tau) = a \frac{\exp i \left[ \left( \zeta^2 / y_1 - \frac{y_2}{2} a^2 \right) x_2 - \zeta / y_1 \tau + \phi \right]}{\cosh a \sqrt{\frac{y_2}{2y_1}} (\tau - \tau_0 - 2\zeta x_2)} \quad (1-4)$$

Whose envelope  $|A| = a \operatorname{sech} a \sqrt{\frac{y_2}{2y_1}} (\tau - \tau_0 - 2\zeta x)$  is a solitary wave

propogating in the  $x_2 \tau$  plane, at the velocity  $\frac{1}{2\zeta}$ , or, in the  $x, t$  plane, at the velocity  $V_s = Cg(1 - 2\epsilon\zeta)^{-1}$

As we shall see later, the soliton is a particular case of the multisoliton, or N-solitons solution which is an exact solution of the C.S.E.; the exact expression of the multisoliton is messy but it has the property to break down as  $v \rightarrow \pm \infty$   $x_2 \rightarrow \pm \infty$  into N individual solitons with different speed and amplitude, with an exponentially small correction.

$$A(x_2, \tau) \sim a_n \exp i \left\{ \left( \frac{\zeta_n^2}{y_1} - \frac{y_2}{2} a_n^2 \right) x_2 - \frac{\zeta_n}{y_1} \tau + \phi_n \right\}$$

$$\operatorname{sech} a_n \sqrt{\frac{y_2}{2y_1}} (\tau - \tau_n - 2\zeta_n x_2)$$

$$\begin{cases} \tau \rightarrow \infty \\ x_2 \rightarrow \infty \\ \tau = 2\zeta_n x_2 + V \quad V \text{ fixed} \end{cases}$$

An observer traveling at the speed  $v_s$  will see, as  $t \rightarrow \pm \infty$  an individual soliton with exponentially small corrections.

• A special limit of the N-soliton is the case of bounded solitons. In this case two or more of the individual solitons have the same speed. They cannot separate. This solution has the property to be periodic in  $x_2$ .

The exact expression of the N-bounded soliton in the special case where  $N = 2$  and  $\zeta_1 = \zeta_2 = 0$  is (reference [19]):

$$A(x, \tau) = 2 \sqrt{\frac{2}{y_2}} \exp\left(i \frac{x_2}{2}\right) \left\{ \cosh 3 \sqrt{y_1} \tau + 3 \exp 4ix_2 \cosh \sqrt{y_1} \tau \right\} \times \left\{ \cosh 4 \sqrt{y_1} \tau + 4 \cosh \sqrt{y_1} \tau + 3 \cos 4x_2 \right\}^{-1} \quad (1-5)$$

It is important to remark that all these soliton solutions satisfy the boundary condition:

A and all its derivatives  $\rightarrow 0$  as  $\tau \rightarrow \pm \infty$

(b)  $y_1 y_2 < 0$  without loss of generality we take  $y_1 > 0$   $y_2 < 0$

i. Stoke's waves:

$$A = A(x_2) = a \exp - i(a^2 y_2 x_2 + \phi) \quad (1-6)$$

It is well known that this solution is linearly stable to side-band disturbances.

ii. Cnoidal waves:

$$A(x_2, \tau) = a \operatorname{sn}\left(a \sqrt{\frac{-y_2}{2y_1}} \tau/m\right) \exp i(\omega_2 x_2) \quad (1-7)$$

where  $m = -(1 + \frac{\omega_2}{y_1 a^2})^{-1}$  and  $S_n$  is a Jacobian elliptic function.

iii. Envelope-hole soliton:

• if  $m \rightarrow 1$  the previous solution becomes

$$A(x_2, \tau) = a \tanh\left(a \sqrt{\frac{-y_2}{2y_1}} \tau\right) \exp(-iy_2 a^2 x_2) \quad (1-8)$$

which is called the phase jump solution. This is a special case of the envelope-hole soliton (reference [7]).

$$A(x_2, \tau) = a(1 - A^2 \operatorname{sech}^2 \chi)^{1/2} \exp(i\tilde{\Omega} \tau - Kx_2 + \sigma(\chi)) \quad (1-9)$$

where:

$$\chi = \frac{x_2 - x_0 - \tau/V_g}{\tau_0}$$

$$V_g = -2\Omega y_1$$

$$\tilde{\Omega} = \Omega - (1 - A^2) \frac{1/2}{V_g \tau_0 A}$$

(1-10)

$$K = -\Omega^2 y_1 + a^2 y_2 \left(\frac{3 - A^2}{2}\right) - (1 - A^2) \frac{1/2}{\tau_0 A}$$

$$a^2 = -\frac{2}{4y_2 \Omega^2 y_1 \tau_0^2 A^2}$$

$$\sigma(\chi) = \sin^{-1} \left\{ A \tanh \chi / (1 - A^2 \operatorname{sech}^2 \chi)^{1/2} \right\}$$

It is easy to see that if we take the limit

$$\left. \begin{array}{l} A \rightarrow 1 \\ \Omega \rightarrow 0 \\ \tau_0 \rightarrow +\infty \end{array} \right\} \text{with } \Omega \tau_0 = \text{constant}$$

in (1-10) and noting that:

$$\sigma(\chi) = \text{Arcsin} \left\{ \text{sign}(\chi) \times (+1) \right\} = \text{sign}(\chi) \times \frac{\pi}{2} \text{ and } (1 - A^2 \text{sech}^2 \chi)^{1/2} \\ \approx |\tanh \chi|$$

the envelope hole soliton reduces to the phase-jump

$$A(x_2, \tau) \sim a \tanh\left(a \sqrt{\frac{-y_2}{2y_1}} \tau\right) \exp - i(y_2 a^2 x_2 - \pi/2)$$

We remark that as  $\tau \rightarrow \pm \infty$

$$\tau \rightarrow +\infty \quad A(x_2, \tau) \sim a \exp - i(y_2 a^2 x_2 - \pi/2)$$

$$\tau \rightarrow -\infty \quad A(x_2, \tau) \sim -a \exp - i(y_2 a^2 x_2 - \pi/2) = a \exp - i(a_2^2 y x_2 + \pi/2)$$

As  $\tau \rightarrow +$  and  $-\infty$  the phase jump soliton behaves like Stoke's waves but with a phase jump of  $\pi$  between  $+$  and  $-\infty$ .

## 2. Study of the Equation when the Coefficients Are Not Constant.

The problem we are interested in is the following (cf Fig. (2) of section I-3-2).

$$\text{Zone (I)} \quad x < 0 \quad h = H_1 \quad U = U_1 \quad \zeta = 0$$

$$\text{Zone (II)} \quad 0 < x < L \quad h = h(x) \quad U = U(x) \quad \zeta = \zeta(x)$$

$$\text{Zone (III)} \quad x > L \quad h = H_2 \quad U = U_2 \quad \zeta = \zeta_2$$

• In regions I and II where  $h$  is constant the coefficients of the equation governing  $A$  are constant. We can then apply the Inverse Scattering method to solve the problem.

$$\left\{ \begin{array}{l} \text{given } A(x_2 = x_0, \tau) \quad x_0 < 0 \text{ we can find by IST } A(x_2, \tau) \text{ for } -\infty < x_2 < 0 \\ \text{given } A(x_2 = x_1, \tau) \quad x_1 > \varepsilon^2 L \text{ we can find by IST } A(x_2, \tau) \text{ for } x_2 > \varepsilon^2 L \end{array} \right.$$

• In region II where the depth varies the coefficients are not

constant and the IST does not apply. The main problem is, given  $A(x = 0, \tau)$  find  $A(x = L, \tau)$ . At present this goal can only be achieved numerically. This will be the object of part III. However, it is possible to find some analytical results which can be useful in themselves or for checking the numerical results.

## 2.1. A particular solution.

(a) Expression of the solution: When the coefficients  $y_1$  to  $y_3$  are only functions of  $x_2$  but not  $t_2$  an exact solution of equation (I-(2-43)) is possible which is the generalization of Stoke's waves for a constant depth.

Let us recall the equation

$$y_1(x_2)A + A_{x_2} + iy_2(x_2)A_{\tau\tau} + iy_3(x_2) |A|^2 A = 0 \quad (2-1)$$

We look for a solution which is only function of  $x_2$ . The equation is then:

$$y_1(x_2)A + \frac{dA}{dx_2} + iy_3(x_2) |A|^2 A = 0 \quad (2-2)$$

Let us write  $A = B(x_2) \exp(-\int_0^{x_2} y_1(u) du)$ . The equation for B is

$$\frac{dB}{dx_2} + iy_3(x_2) \exp(-2 \int_0^{x_2} y_1(u) du) |B|^2 B = 0 \quad (2-3)$$

Let us now write  $B = b_0 \exp if(x_2)$  where  $b_0$  is a constant and  $f(x_2)$  is real then  $f$  is one solution of

$$i f'(x_2) + iy_3(x_2) \exp(-2 \int_0^{x_2} y_1(u) du) b_0^2 = 0 \quad (2-4)$$

$$f(x_2) = -b_0^2 \int_0^{x_2} y_3(v) \exp(-2 \int_0^v y_1(u) du) dv - \phi$$

with  $\phi$  being an arbitrary constant.



A is then given by

$$A(x_2) = b_0 \exp\left(-\int_0^{x_2} y_1(u) du\right) \exp -i \left[ \int_0^{x_2} y_3(v) \exp\left(-2 \int_0^v y_1(u) du\right) dv + \phi \right] \quad (2-5)$$

since  $y_1(u) = \frac{1}{2Cg/\sigma} \frac{d Cg/\sigma}{dx_2} = \frac{d \ln(Cg/\sigma)}{d x_2}$

we get

$$\exp\left(-\int_0^{x_2} y_1(u) du\right) = \sqrt{\frac{Cg(o)}{\sigma}} / \sqrt{\frac{Cg}{\sigma}(x_2)}$$

Define the local amplitude  $b(x_2)$  by

$$b(x_2) = b_0 \exp - \int_0^{x_2} y_1(u) du$$

we get

$$b(x_2) \sqrt{\frac{Cg}{\sigma}} = b_0 \sqrt{\frac{Cg_0}{\sigma_0}} \quad (2-6)$$

Using this result (2-5) may be written as:

$$A(x_2) = b(x_2) \exp - i \int_0^{x_2} y_3(v) b^2(v) dv \quad (2-7)$$

Therefore on a slowly varying bottom  $h = h(x_2)$  the Stoke's waves amplitude transform according to the linear law (2-6) while the phase changes according to the nonlinear law for a constant depth if the local depth is used.

In the special case of a constant depth  $y_1 = 0$   $y_3 = \text{constant}$  and

$$A = b_0 \exp - i(b_0^2 y_3 x_2 + \phi) \quad (2-8)$$

(c) Linear Stability of the Solution: it is well known that Stoke's waves for the cubic Schrödinger equation with constant coefficients:

$$A_{x_2} + i\lambda A_{\tau\tau} + i\nu |A|^2 A = 0 \quad \text{are}$$

i. Linearly unstable for  $\lambda\nu > 0$  which corresponds to deep water for which envelopesolitons exist.

ii. Linearly stable for  $\lambda\nu < 0$  which corresponds to shallow water for which envelope solitons do not exist but envelope-hole solitons exist.

This is the so-called Benjamin Feir Instability (reference [2]). This result can be extended to the solution found previously. The proof is as follows:

We consider the equation  $y_1(x_2)A + A_{x_2} + iy_2(x_2)A_{\tau\tau} + iy_3(x_2) |A|^2 A = 0$  As in (a) we write  $A = \exp(-\int_0^{x_2} y_1(u)du) B$ . If we furthermore write  $B = b \exp i\phi$  where  $b$  and  $\phi$  are real. By taking real and imaginary part the equation is equivalent to:

$$\begin{cases} b_{x_2} - 2y_2(x_2)b_{\tau}\phi_{\tau} - y_2(x_2)b \phi_{\tau\tau} = 0 \\ b\phi_{x_2} + y_2(x_2)b_{\tau\tau} - y_2(x_2)b \phi_{\tau}^2 + y_3'(x_2)b^3 = 0 \end{cases} \quad (2-9)$$

$$\text{where } y_3'(x_2) = y_3(x_2) \exp(-2 \int_0^{x_2} y_1(u)du) \quad (2-10)$$

Let  $\phi_{\tau} = W$  the equations for  $W$  and  $b$  are after some algebra:

$$\begin{cases} \frac{\partial b^2}{\partial x^2} - 2y_2(x_2) \frac{\partial (b^2 W)}{\partial \tau} = 0 \\ \frac{\partial W}{\partial x_2} + \frac{\partial}{\partial \tau} \left\{ y_2(x_2) \left( \frac{b_{\tau\tau}}{b} - W^2 \right) + y_3'(x_2)b^2 \right\} = 0 \end{cases} \quad (2-11)$$

The Stoke's waves solution satisfies:

$$\begin{cases} b = b_0 = \text{constant} \\ \phi \text{ is independent of } \tau \Rightarrow W = 0 \end{cases}$$

Let us consider the linear stability of these Stoke's waves; for this we superpose to the original solution  $b = b_0$ ,  $W = 0$ , a small disturbance  $b' \ll 1$ ,  $W' \ll 1$ , we plug in the equations and linearize in  $b'$ ,  $W'$ .

The equations for  $b'$  and  $W'$  are then

$$\begin{cases} 2b_0 b'_{x_2} - 2y_2(x_2) b_0^2 W'_{\tau} = 0 \\ W'_{x_2} + \frac{y_2(x_2)}{b} b'_{\tau\tau} + y_3'(x_2) 2b_0 b'_{\tau} = 0 \end{cases} \quad (2-12)$$

Then we assume disturbance of the form:

$$\begin{cases} b' = \hat{b} \exp i(f(x_2) - \Omega\tau) \\ W' = \hat{W} \exp i(f(x_2) - \Omega\tau) \end{cases} \quad (2-13)$$

The problem we want to study is: if one disturbance which is periodic in  $\tau$  ( $\Omega$  real) is given, will it be amplified in  $x_2$ ? This will be the case if  $\text{Real}(f(x_2))$  is positive. Note that  $\tau = 0(1)$  corresponds to

$\int \frac{dx}{Cg} - t = 0(\frac{1}{\epsilon})$  which is much smaller than  $x$ . Hence (2-13) may be assumed. If we plug the expression for  $b'$  and  $W'$  in the equations we find:

$$\begin{cases} i2b_0 f'(x_2) \hat{b} + iy_2(x_2) b_0^2 \Omega \hat{W} = 0 \\ i\hat{W} f'(x_2) + i\Omega^3 y_2(x_2) \frac{\hat{b}}{b_0} - 2y_3'(x_2) i\Omega \hat{b} = 0 \end{cases} \quad (2-14)$$

The linear homogeneous system has a nontrivial solution if and only if the coefficients determinant is zero:

$$(f'(x_2))^2 = 2y_2(x_2)^2 b_0^2 \Omega^2 \left\{ \frac{\Omega^2}{2b_0^2} - \frac{y_3'(x_2)}{y_2(x_2)} \right\} \quad (2-15)$$

As  $y_3'(x_2) = y_3(x_2) \exp - 2 \int_0^{x_2} y_1(u) du$ ,  $y_3$  and  $y_3'$  have the same sign.

We find the same results as for constant coefficients:

i. If  $y_3(x_2)y_2(x_2) < 0$  then for any  $\Omega$   $f'(x_2)$  is real,  $f(x_2)$  is real the disturbance will not be amplified in space.

ii. If  $y_3(x_2)y_2(x_2) > 0$  then if  $\Omega$  is sufficiently small

$f'(x_2)^2 < 0 \Rightarrow f'(x_2) = a \pm ib \Rightarrow if(x_2)$  may have a positive real part  $\Rightarrow$  There is some amplification along the x axis. (But the amplification may be limited if  $f(x_2)$  is bounded, which is not the case for constant coefficients where  $f(x_2) = Kx_2$ .)

Case i. is always stable.

Case ii. may be unstable.

## 2.2. Evolution laws.

When the coefficients are constant it is well known that the cubic Schrödinger equation admits an infinite number of conservation laws, i.e., it is possible to construct an infinite number of  $P_n, Q_n$   $n = 1, 2, \dots$  depending on  $A$  and its derivatives, such that  $\frac{\partial P_n}{\partial x_2} + \frac{\partial Q_n}{\partial \tau} = 0$  (2-16)

If  $A$  and all its derivatives vanish at  $\tau = \pm \infty$  it gives the infinite number of conserved quantity:

$$\frac{\partial}{\partial x} \int_{-\infty}^{+\infty} P_n d\tau = 0 \quad \Rightarrow \quad \int_{-\infty}^{+\infty} P_n(x_2, \tau) d\tau = \text{constant} \quad (2-17)$$

These conservation laws are physically important since they express the conservation of mass, energy . . . . Mathematically the existence of an infinite number of conservation laws seems to be strongly related to the fact that the evolution equation is solvable by the Inverse Scattering Method.

When the coefficients are not constants it is no longer possible to have these conservation laws but we can find their equivalent, which we call evolution laws since, for the first at least, they allow us to follow the evolution of certain quantities. Here we only derive the first three evolution laws by guessing their form (for this we use obviously the conservation laws for the cubic Schrödinger equation with constant coefficients).

To simplify the algebra we make the following transformations

$$A = \exp\left(-\int_0^{x_2} y_1(u) du\right) \hat{B} \quad \text{and} \quad \hat{B}(x_2, \tau) = B(x, \tau) \quad \text{where}$$

$$x = \int_0^{x_2} y_1(u) du$$

Then it is easy to check that B is solution of

$$B_x + i B_{\tau\tau} + i v(x) |B|^2 B = 0 \quad (2-18)(E)$$

where  $v(x) = \frac{y_3(x_2(x))}{y_2(x_2(x))} \exp -2 \int_0^{x_2(x)} y_1(u) du$

it is easier to study the evolution laws on this equation which will also be called (E) for convenience.

(a) First evolution law: Energy equation

We simply take (E)  $B^* + (E)^* B$  where \* means complex conjugate.

Then

$$B_x B_x^* + B_x^* B_x + i \{ B_{\tau\tau} B^* - B_{\tau\tau}^* B \} + i v(x) |B|^4 - i v(x) |B|^4 = 0$$

$$\Leftrightarrow |B|_x^2 + i \{ (B_{\tau} B^*)_{\tau} - B_{\tau} B_{\tau}^* - [(B_{\tau}^* B)_{\tau} - (B_{\tau}^* B)_{\tau}] \} = 0 \quad (2-19)$$

$$\frac{\partial |B|^2}{\partial x} + i \frac{\partial (B_{\tau} B^* - B_{\tau}^* B)}{\partial \tau} = 0 \quad \text{this is really a conservation law for B;}$$

if we assume  $B_{\tau} \rightarrow 0$  and  $B \rightarrow 0$  as  $\tau \rightarrow \pm \infty$  this equation gives by integration:

$$\frac{\partial}{\partial x} \int_{-\infty}^{+\infty} |B|^2 d\tau = 0 \quad \text{or} \quad \int_{-\infty}^{+\infty} |B(x, \tau)|^2 d\tau = \text{constant} \quad (2-20)$$

This gives for A, and after using I3-7:

$$\frac{Cg}{\sigma} (x_2) \int_{-\infty}^{+\infty} |A(x_2, \tau)|^2 d\tau = \text{constant} \quad (2-21)$$

To find the next evolution laws the algebra is still very simple but more messy. Let us give only the initial step and the result.

(b) Second evolution law: if we consider (E)  $B_{\tau}^* + (E)^* B_{\tau}$ , we obtain

$$\frac{1}{2} \frac{\partial}{\partial x} (B^* B_\tau - B_\tau^* B) + \frac{\partial}{\partial \tau} \left\{ \frac{1}{2} (B_x^* B - B^* B_x) + i |B_\tau|^2 + \frac{i v(x)}{2} |B|^4 \right\} = 0$$

This is still a conservation law for B. If we assume once more  $B \rightarrow 0$

$B_\tau \rightarrow 0$   $B_x \rightarrow 0$   $\tau \rightarrow \pm \infty$  we have

$$\int_{-\infty}^{+\infty} (B^* B_\tau - B_\tau^* B) d\tau = \text{constant or} \quad (2-22)$$

$$\exp\left(2 \int_0^{x_2} y_1(u) du\right) \int_{-\infty}^{+\infty} \{ A^*(x_2, \tau) A_\tau(x_2, \tau) - A_\tau^*(x_2, \tau) A(x_2, \tau) \} d\tau = \text{constant} \quad (2-23)$$

which is still an evolution law for A

(c) If we consider  $(E) B_x^* - (E)^* B_x$  we get:

$$\frac{\partial}{\partial \tau} (B_x B_\tau^* + B_x^* B_\tau) - \frac{\partial}{\partial x} |B_\tau|^2 + \frac{v(x)}{2} \frac{\partial |B|^4}{\partial x} = 0 \quad (2-24)$$

Since  $v$  is function of  $x$  this expression is no longer of the form of a conservation law for B; no corresponding evolution law for A can be found.

One consequence of relation (2-24) is that the method used by Mei, reference [12] to study the evolution of the soliton of KdV equation moving over variable depth, is no longer possible. In this method it is assumed that as the depth changes the soliton, which is given at  $x = 0$  by  $A(0, \tau) = a^2 \text{sech}^2 a\tau$ , see reference [8], conserves its shape, i.e., at the end of the depth change the profile is given by  $A = b \text{sech}^2 K(\tau - \tau_0)$ .  $b$  and  $K$  are then found by using two evolutions laws. If we try to do the same for the cubic Schrödinger equation, i.e., if we assume at the end of depth variation a sech profile  $A = b \text{sech} K\tau$  it is not possible to find  $b$  and  $K$  by using evolution laws. Indeed the first one gives us

$\frac{b^2}{K}$  the second nothing (since A is real  $A^*_\tau A - A^*A_\tau = 0$  so 2-23 gives  $0 = 0$ ). Since there are no other evolution laws we have only one relation for the two unknown b and K.

One important consequence of the first evolution law:

The first evolution law can be written as:

$$\frac{Cg}{\sigma}(x_2) \int_{-\infty}^{+\infty} |A(x_2, \tau)|^2 d\tau = \text{constant}$$

It is well known result of linear theory that, when the waves propagate against the current, the shoaling coefficient  $\frac{Cg}{\sigma}$  can become zero. This happens when the current is such that the following relation is satisfied: (see for instance reference [12] chapter 2)

$$U(x_2) = -\frac{C_p}{2}$$

As  $C_p$  depends on k which depends on U, this is an implicit relation for U. The place where  $U = -\frac{C_p}{2}$  is called a caustic, at which our nonlinear theory predicts:

$$\int_{-\infty}^{+\infty} |A(x_2, \tau)|^2 d\tau = \infty$$

which is the extension of the linear result:

$$|A(x_2)| = \infty \text{ at the caustic}$$

Obviously near the caustic our nonlinear theory fails. To study the waves near the caustic a localized study using inner variables is needed. Some attempt has been done in this field, see for instance Smith reference [21].



PART III: NUMERICAL STUDY.

In this part we want to solve quantitatively the problem described in section I-3-2 which is summarized in Figure (2):

$$\left\{ \begin{array}{llll} x < 0 & h = h_1 = \text{constant} & U = U_1 & \zeta = 0 \\ 0 < x < L & h = h(x_2) & U = U(x_2) & \zeta = \zeta(x_2) \text{ stationary current} \\ x > L & h = h_2 = \text{constant} & U = U_2 & \zeta = \zeta_2 \end{array} \right.$$

$x < 0$  will be called region (1);  $x > L$  region (2); in addition we will use the following notation:  $G|_i$  means value of the function  $G$  in the region  $i$  ( $i = 1, 2$ )

1. The Finite Difference Method.

1.1. Preliminary:

The procedure is as follows:

i. Specify the dimensionless parameter of the problem

- dimensionless velocity of the current at  $-\infty$   $u_-$
- dimensionless period  $T$
- dimensionless depth profile for  $x < 0$   $h = 1$

for  $x > 0$   $h = h(x_2)$  to be given

ii. Solve for the dimensionless total depth, i.e., solve for

$\chi$  from the cubic equation:

$$\chi^3 - (h(x_2) + \frac{u_-^2}{2}) \chi^2 + \frac{u_-^2}{2} = 0 \tag{1-1}$$

such that  $\chi(x_2)$  is continuous and approaches 1 as  $h(x_2) \rightarrow 1$ .

iii. Solve for the dimensionless wave-number  $k$  from

$$(\omega - Uk)^2 = k \tanh k \chi \tag{1-2}$$

where  $\omega = \frac{2\pi}{T}$  and  $U = \frac{u}{\chi}$

In general this equation has two roots; we choose arbitrarily to take one (we have always taken the smallest one).

### 1.2. Method used to solve the cubic Schrödinger equation.

The problem we have to solve is:

$$\left\{ \begin{array}{l} A_{x_2} = y_1(x_2)A + iy_2(x_2)A_{\tau\tau} + iy_3(x_2) |A|^2 A = 0 \\ \text{on } D = \{ 0 < x_2 < +\infty ; -\infty < \tau < -\infty \} \\ A(x_2 = 0; \tau) = f(\tau) \text{ given} \\ + \text{condition at infinity; for instance } A(x_2, \tau) \rightarrow 0 \text{ as } |\tau| \rightarrow \infty \end{array} \right.$$

First we restrict the infinite domain  $D$  to a finite one  $D_F = \{ 0 < x_2 < x_0 ; -\tau_0 < \tau < \tau_0 \}$  where we have in particular to choose  $\tau_0$  sufficiently large since we will write the conditions at  $\tau = \pm \infty$ , at  $\tau = \pm \tau_0$

We use to solve the equation a finite difference method. If  $\delta x_2$  and  $\delta \tau$  are the width of the discretisation intervals, if  $x_0 = (N - 1) \delta x_2$  and  $\tau_0 = (J - 1) \delta \tau$  then, the unknowns are:

$$A_j^n = A((n-1)\delta x_2; (j - J)\delta \tau) = A(x_n; \tau_j) \quad (1-4)$$

$$\text{where } \left\{ \begin{array}{l} n = 1, \dots, N \quad (\text{for } n = 1 \quad x_n = 0; \text{ for } n = N \quad x_n = x_0) \\ j = 1, \dots, 2J - 1 \quad (\text{for } j = 1 \quad \tau_j = -\tau_0; \text{ for } j = 2J - 1 \quad \tau_j = +\tau_0) \end{array} \right.$$

Now for simplicity we shall write  $J$  for  $2J - 1$ .

To compute  $A_j^n$  we use an implicit scheme of Crank-Nicholson type for integration in  $x_2$  and centered second order differencing in  $\tau$ ; this scheme is known to be unconditionally stable for the linear case with constant coefficient; it has already been used in reference [27] for the nonlinear

case with constant coefficient and is stable for reasonable  $\delta x_2$  and  $\delta \tau$ .

The error due to discretization is  $O(\delta x_2^2, \delta \tau^2)$ .

The equations for  $A_j^n$  are  $(y_i(n) = y_i((n-1)\delta x_2) = y_i(x_n))$

$$\frac{A_j^{n+1} - A_j^n}{\delta x_2} + \frac{y_1(n+1) + y_1(n)}{2} A_j^n + i \frac{y_2(n+1) + y_2(n)}{2}$$

$$\left\{ \frac{A_{j+1}^{n+1} - 2A_j^{n+1} + A_{j-1}^{n+1}}{2(\delta \tau)^2} + \frac{A_{j+1}^n - 2A_j^n + A_{j-1}^n}{2(\delta \tau)^2} \right\}$$

$$+ i \frac{y_3(n+1) + y_3(n)}{2} \left\{ |A_j^{n+1}|^2 A_j^{n+1} + |A_j^n|^2 A_j^n \right\} = 0 \quad (1-5)$$

where the nonlinear term  $\tilde{A}_j^{n+1}$  is given by:

$$\tilde{A}_j^{n+1} = A_j^n + \delta x_2 \left\{ -y_1(n) A_j^n - iy_2(n) \frac{A_{j+1}^n - 2A_j^n + A_{j-1}^n}{(\delta \tau)^2} \right.$$

$$\left. - iy_3(n) |A_j^n|^2 A_j^n \right\} \quad (1-6)$$

The finite difference equation can be written as

$$A_{j+1}^{n+1} \frac{i\delta x_2}{2(\delta \tau)^2} \frac{(y_2(n+1) + y_2(n))}{2} + A_j^{n+1} \left[ 1 + \frac{\delta x_2}{2} \left\{ \frac{y_1(n+1) + y_1(n)}{2} \right. \right.$$

$$\left. \left. - i \frac{y_2(n+1) + y_2(n)}{(\delta \tau)^2} + i \frac{y_3(n+1) + y_3(n)}{2} |A_j^{n+1}|^2 \right\} \right] +$$

$$A_{j-1}^{n+1} \frac{i\delta x_2}{2(\delta \tau)^2} \frac{(y_2(n+1) + y_2(n))}{2} = A_j^n \left[ 1 - \frac{\delta x_2}{2} \left\{ \frac{y_1(n+1) + y_1(n)}{2} \right. \right.$$

$$\left. \left. - i \frac{y_2(n+1) + y_2(n)}{(\delta \tau)^2} + i \frac{y_3(n+1) + y_3(n)}{2} |A_j^n|^2 \right\} \right]$$

$$-\frac{\delta x_2}{2(\delta\tau)^2} \frac{y_2(n+1) + y_2(n)}{2} (A_{j+1}^n + A_{j-1}^n) \quad (1-7)$$

If the conditions at  $|\tau| \rightarrow \infty$  are  $A(x, \tau) \rightarrow 0$  we have then  $A_1^m = 0 = A_J^m$   
 $m = 1, \dots, N$ ; the system for  $A_j^n$  is then:

$$\begin{cases} \alpha_2^n A_3^{n+1} + \beta_2^n A_2^{n+1} = w_2^n \\ \alpha_j^n A_{j+1}^{n+1} + \beta_j^n A_j^{n+1} + \gamma_j^n A_{j-1}^{n+1} = w_j^n \text{ for } j = 2, \dots, J-2 \\ \beta_{J-1}^n A_{J-1}^{n+1} + \gamma_{J-1}^n A_{J-2}^{n+1} = w_{J-1}^n \end{cases} \quad (1-8)$$

for  $n = 1, \dots, N-1$

where  $\alpha_j^n, \beta_j^n, \gamma_j^n, w_j^n$  are known once  $A_j^n \quad j = 1, \dots, J$  are known.

The procedure is then straight forward:

- i. We know  $A_j^1 \quad j = 1, \dots, J$  (initial data at  $x = 0$ ) we can then solve for  $A_j^2 \quad j = 1, \dots, J$
- ii. Next we solve for  $A_j^3 \quad j = 1, \dots, J$  etc. . . till we have  $A_j^N \quad j = 1, \dots, J$

Remark: if the initial data  $f(\tau) = A(x_2 = 0; \tau)$  is even in  $\tau$  then as  $\tau$  appears in the equation as  $A_{\tau\tau}$ , it is obvious that the solution  $A(x_2, \tau)$  is even in  $\tau$ ; by imposing at  $\tau = 0$  the condition  $\frac{\partial A}{\partial \tau}(x_2; \tau = 0) = 0$  we can solve the problem for  $\tau \geq 0$  only.

### 1.3. Inversion scheme to solve the linear matrix equation.

The linear system is of the form:

$$\begin{cases} \alpha_1 A_2 + \beta_1 A_1 = w_1 & (1-9a) \\ \alpha_j A_{j+1} + \beta_j A_j + \gamma_j A_{j-1} = w_j & (1-9b) \\ \beta_J A_J + \gamma_J A_{J-1} = w_J & (1-9c) \end{cases}$$

We solve it by the method explained in reference [18]. We introduce intermediate variables  $x_j$  and  $y_j$  such that

$$A_{j+1} = x_j A_j + y_j \quad (1-10)$$

i. By plugging in the equation (1-9b) we find the recurrence relation:

$$x_{j-1} = \frac{-\gamma_j}{(\alpha_j x_j + \beta_j)} \quad y_{j-1} = \frac{w_j - \alpha_j y_j}{(\alpha_j x_j + \beta_j)} \quad (1-11)$$

$$\text{ii. The equation for } j = J \text{ gives } x_{J-1} = -\frac{\gamma_J}{\beta_J} \quad y_{J-1} = \frac{w_J}{\beta_J} \quad (1-12)$$

by using i. we have then  $x_j, y_j$  for  $j = 1, \dots, J - 1$

iii. The equation for  $j = 1$  gives us

$$A_1 = \frac{w_1 - \alpha_1 x_1}{\alpha_1 x_2 + \beta_1} \quad (1-13)$$

We have then by  $A_{j+1} = A_j x_j + y_j$ , all the  $A_j$

#### 1.4. Check of the numerical results.

• The program has been checked by taking a constant depth. In this case the equation is the cubic Schrödinger equation with constant coefficients. Some exact solutions are known which permit us to check the numerical results.

Two cases have been studied. The soliton solution and the 2-bounded soliton solution (cf reference [19]). The results are shown on Figure (1) and (2) on which we plot the envelope of the waves as a function of  $x_2$  and  $\tau$ .

i. In Figure (4) the initial profile is  $A(0, \tau) = \frac{2}{\sqrt{y_3}} \operatorname{sech}\left(\frac{2 \tau}{\sqrt{2y_2}}\right)$

which is a soliton. The exact solution (cf II 1-2) indicates that there should not be any deformation of the envelope. This result is found numerically.

For this example we have taken  $U = 0.4$ ,  $T = 3$ .  $h = 1$  everywhere and studied the envelope for:

$$\begin{cases} x_2 = 0 \text{ to } 9 \\ \tau = 0 \text{ to } 5 \end{cases}$$

ii. In Figure (5) the initial profile is

$$A(0, \tau) = \frac{2}{\sqrt{y_3}} \operatorname{sech} \frac{\tau}{\sqrt{2y_2}}$$

The exact solution is then (cf reference [19]) two-bounded solitons which is a periodic function of  $x_2$  whose form is well known (cf references [19], [27] or [12]). The numerical results give this exact solution.

In this example we have taken  $U = 0.4$   $T = 3$   $h = 1$  everywhere and studied the envelope for:

$$\begin{cases} x_2 = 0 \text{ to } 4.2 \\ \tau = 0 \text{ to } 5 \end{cases}$$

• When the coefficients are not constant we checked our numerical

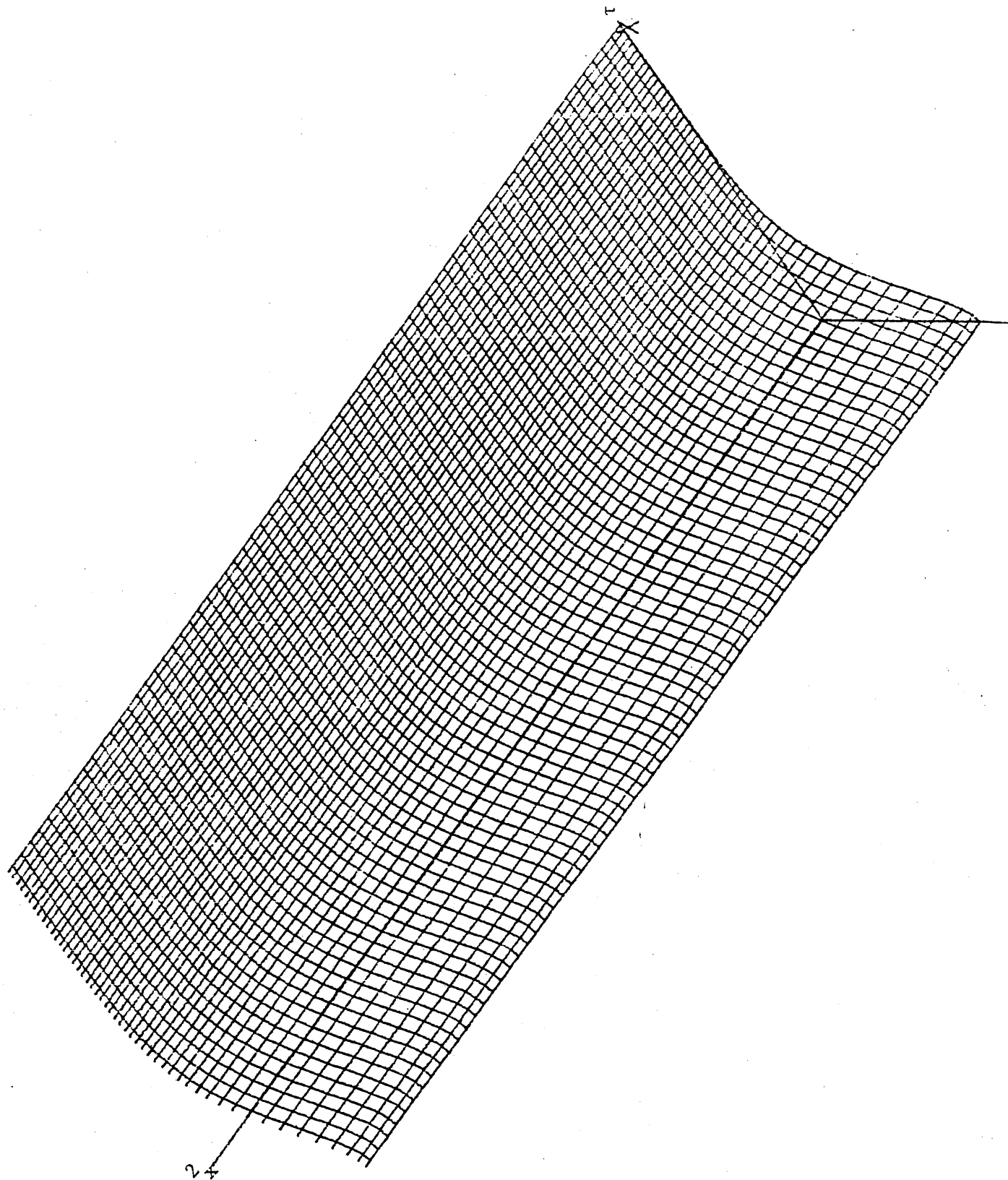

Figure (4)

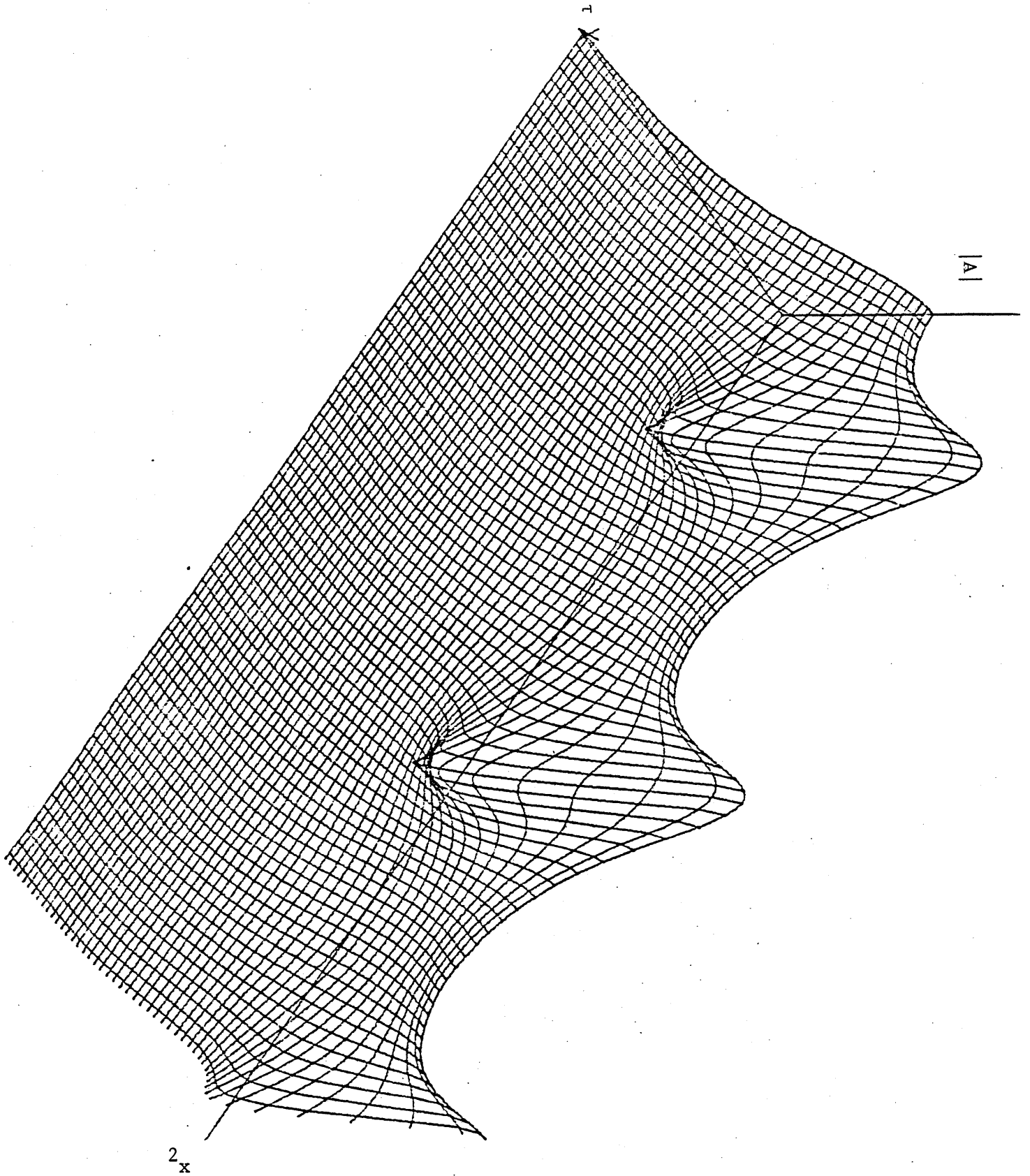

Figure (5)



results by using the first evolution law (II-2-2)

$$\frac{C_g}{\sigma} \int_{-\infty}^{+\infty} |A(x_2, \tau)|^2 d\tau = \text{constant}$$

In all the numerical results which are presented here this law is satisfied within a few percent.

## 2. Numerical Results.

### 2.1. Variation of the coefficients.

It is important before doing any numerical study to examine the variations of the coefficients of the equation, the wave number and the shoaling coefficient  $\frac{C_g}{\sigma}$  as the free parameters vary. In particular we must first know the sign of  $y_2 y_3$ . We have conducted a numerical study of these terms. The numerical values are given in Appendix D for the following cases:

U = 0., 0.4, 0.8, 1.2, 1.6 and T = 3., 5., 7. as h varies from  $h_c$  to  $h_c + 1$

The results may be summarized as follows:

- Without current: As h increases, k decreases  $y_2$  is always positive,  $y_3$  is negative in shallow water:  $kh < 1.363$  and positive in deep water:  $kh > 1.363$ . This result is well known.

- Effect of the current: Here  $y_2$  is always positive,  $y_3$  can be either positive or negative. From the numerical examples we have studied we conclude that

$$\begin{cases} y_3 \text{ is positive if } k(\zeta + h) > (k(\zeta + h))_0 \\ y_3 \text{ is negative if } k(\zeta + h) < (k(\zeta + h))_0 \end{cases}$$

$$(k(\zeta + h))_0 \sim 1.36$$

Furthermore in the range of variation of  $h$  studied we have as  $h$  increases:

i. If  $U < 1$  (i.e. in physical variable  $U < \sqrt{gH_1}$ )  
 $k(\zeta + h)$ ,  $y_2, y_3$  increase while  $Cg$  and  $\frac{Cg}{\sigma}$  decrease.

ii. If  $U > 1$   
 $k(\zeta + h)$ ,  $y_2, y_3$  decrease while  $Cg$  and  $\frac{Cg}{\sigma}$  increase.

Let us make the following remarks on these results:

-- If we compare these results for  $U > 1$  and  $U < 1$  it seems that to be consistent we should have, when  $U = 1$ ,  $k(\zeta + h)$ ,  $y_2, y_3$ ,  $Cg$  and  $\frac{Cg}{\sigma}$  constant as the depth varies. This is not the case. The reason is that when  $U = 1$  the Airy's equations which, for a stationary current, reduce to a cubic equation for the total depth, admit two solutions (See Appendix D). Mathematically it is not possible to choose between these two solutions. Physically we can choose one by arguing that  $U$  is slightly smaller or slightly greater than 1.

-- One interesting conclusion is the following:

If  $U < 1$   $y_3$  increases as  $h$  increases;  $y_3$  is negative in shallow water and positive in deeper water. Furthermore  $\frac{y_3}{2y_2}$  increases with the depth.

When  $y_3$  is positive we know that  $K = \sqrt{\frac{y_3}{2y_2}}$  characterizes the steepness

of a soliton  $A = a \operatorname{sech} a \sqrt{\frac{y_3}{2y_2}} (\tau - \tau_0)$ . So, in this case, for a given

amplitude a soliton is flatter in shallow water than it is in deeper water. If  $U > 1$   $y_3$  and  $\frac{y_3}{2y_2}$  decreases as  $h$  increases, the opposite

results hold.

The general influence of the current, which is quite strong, can be seen in table (1) where we give some values of the coefficients  $k$ ,  $C_g$ ,  $\frac{C_g}{\sigma}$ ,  $y_2$ ,  $y_3$  and  $K = \sqrt{\frac{y_3}{2y_2}}$  for  $h = 1$ .

On Figure (7) we give the curves  $y_3$  as a function of  $k(\zeta + h)$  for 3 different cases. The intersection of the curves at  $y_3 = 0$   $k(\zeta + h) = 1.363$  is quite clear.

On Figure (8) we give the curves  $K = \sqrt{\frac{y_3}{2y_2}}$  as a function of  $h$  for different cases. The very strong effect of the period can be seen by comparing curve (1) ( $T=3.$ ) with curve (2) and (3) ( $T=5.$ ).

## 2.2. Study of the amplitude of the waves.

The transition zone  $0 < x < L$  is always chosen to be a cosine curve, i.e.,  $h = 1 + dh \left\{ 1 - \cos \frac{\pi x}{L} \right\}$

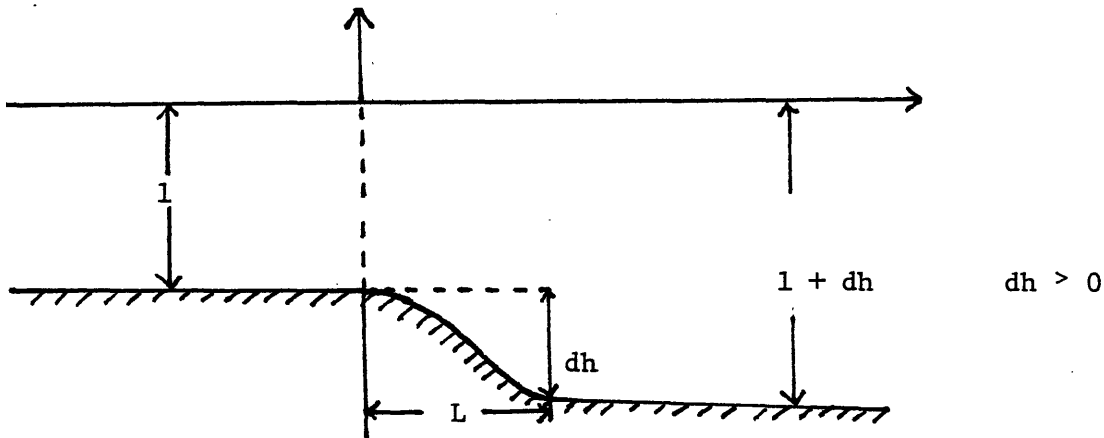

Figure (6-a)

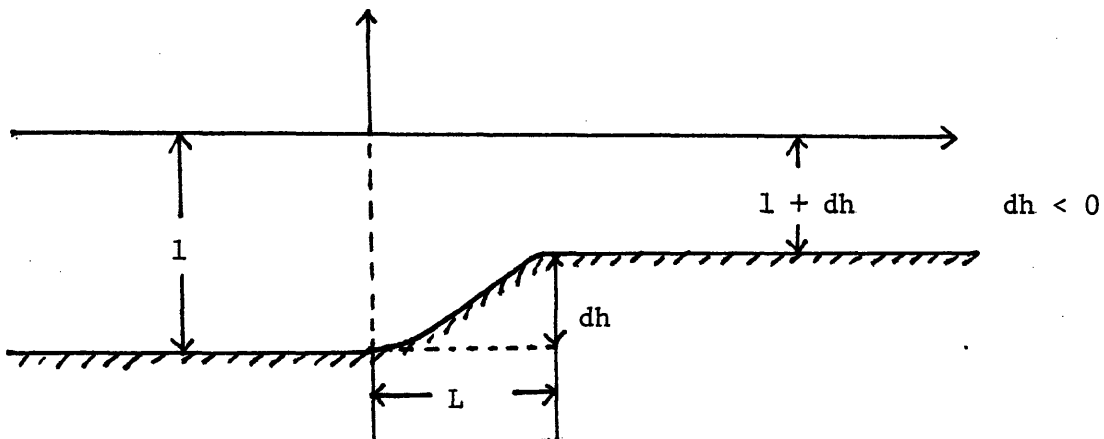

Figure (6-b)

	T = 3.						T = 5.						T = 7.					
	k	Cg	Cg/σ	y <sub>2</sub>	y <sub>3</sub>	K	k	Cg	Cg/σ	y <sub>2</sub>	y <sub>3</sub>	K	k	Cg	Cg/σ	y <sub>2</sub>	y <sub>3</sub>	K
U=0.	4.38	0.239	0.114	19.9	253	2.52	1.69	0.457	0.364	3.36	4.72	0.83	1.03	0.66		0.746	-2.48	*
U=0.1	3.17	0.386	0.217	4.76	61	2.53	1.4	0.63	0.566	1.17	0.387	0.406	0.905	0.816	1.01	0.322	-2.75	*
U=0.2	2.54	0.531	0.335	1.99	22.15	2.35	1.22	0.792	0.782	0.53	-0.96	*	0.81	0.958	1.30	0.162	-2.820	*
U=0.3	2.15	0.675	0.466	1.03	9.68	2.16	1.08	0.941	1.01	0.276	-1.49	*	0.734	1.1	1.61	0.09	-2.825	*
U=0.4	1.88	0.818	0.61	0.59	4.8	2.016	0.98	1.083	1.25	0.157	-1.74	*	0.67	1.21	1.93	0.054	-2.807	*
U=0.8	1.297	1.36	1.293	0.109	-0.26	*	0.729	1.59	2.36	0.028	-1.95	*	0.51	1.68	3.44	0.01	-2.71	*
U=1.2	1.02	1.872	2.12	0.03	-0.9	*	0.584	2.05	3.7	0.008	-1.94	*	0.413	2.12	5.27	0.003	-2.64	*
U=1.6	0.836	2.34	3.1	0.01	-1.09	*	0.49	2.49	5.28	0.003	-1.91	*	0.347	2.54	7.45	0.001	-2.6	*

Table (1) Values of k, Cg, Cg/σ (shoaling coefficient) y<sub>2</sub>, y<sub>3</sub> and  $K = \sqrt{\frac{y_3}{2y_2}}$  (when y<sub>3</sub> > 0) for h = 1

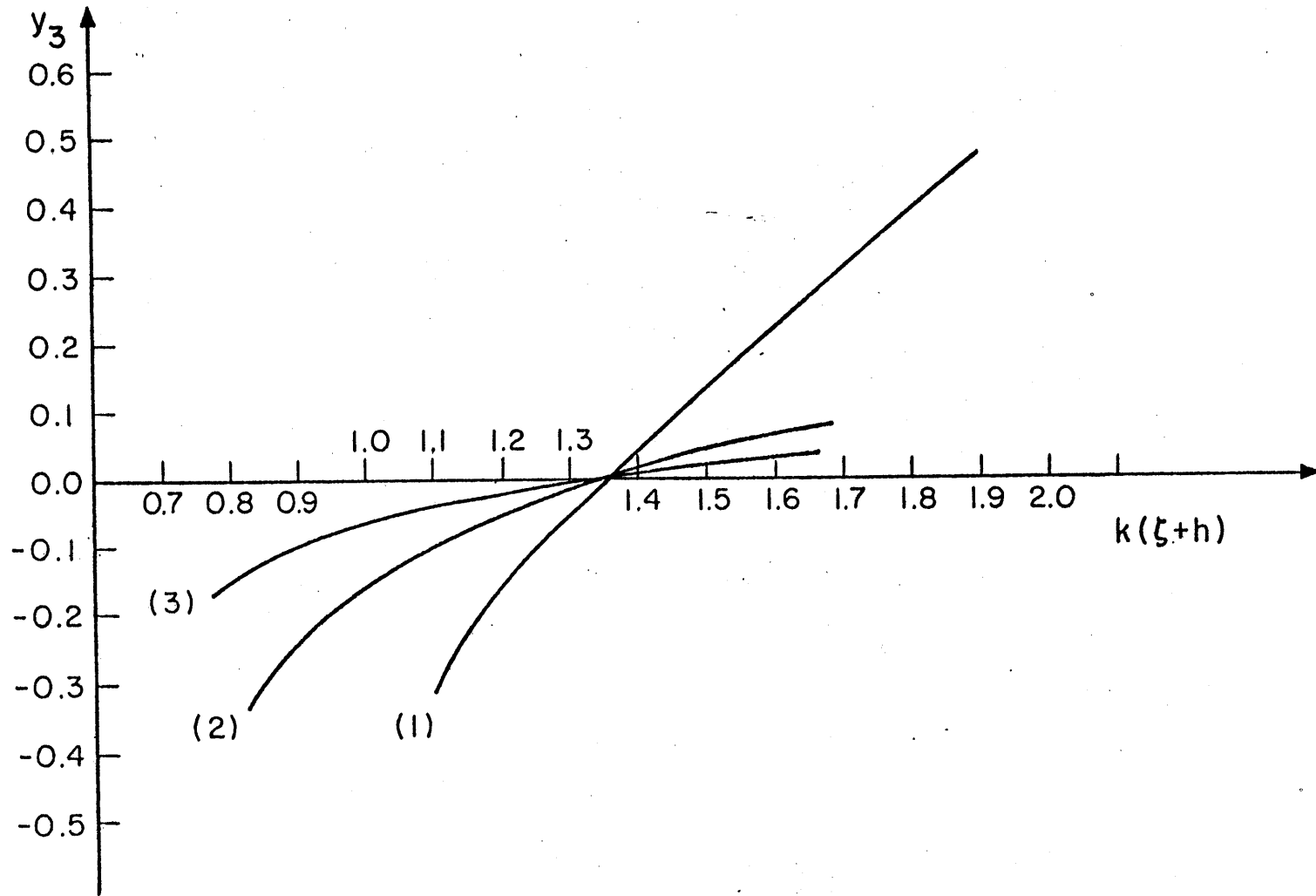

Figure (7)

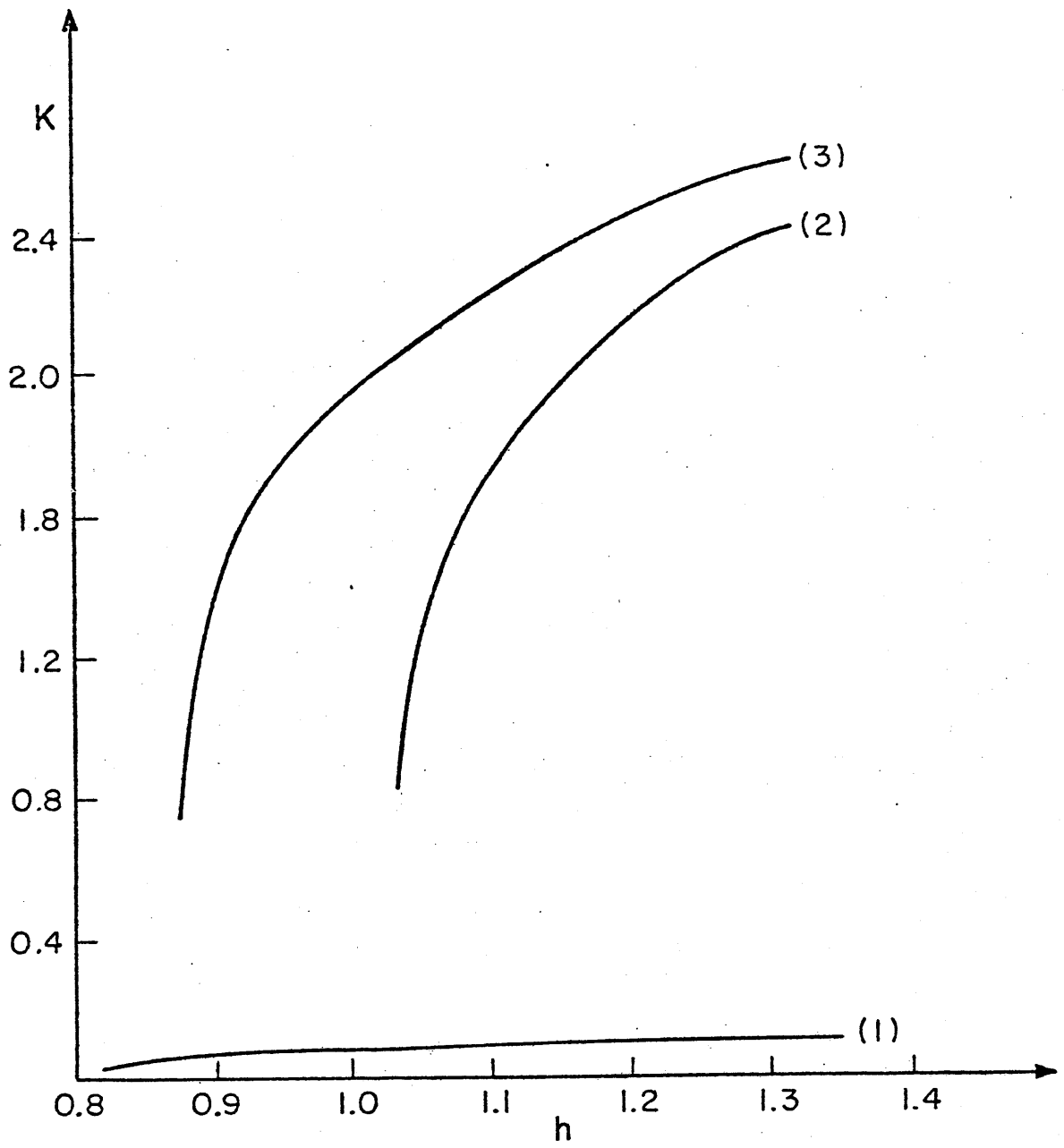

Figure (8)

As we will see, even for a very limited range of initial profile  $A(x_2, \tau)$  very different comportments are found. It is not our goal to do a systematic study of all the possible cases; we will only try to find the typical features that can occur. As the important parameters of the problem are the coefficients of the equation and especially the sign of  $y_2 y_3$ , it is easy by using Appendix D and the few plots we have drawn, to see, given some physical parameters,  $U$ ,  $T$ , depth profile, what should be the qualitative evolution of the envelope of the waves.

2.2.1. Study of the fission of soliton when  $y_2 y_3 > 0$  everywhere.

We consider the case where the depth profile and  $U_1$  are such that  $y_2 y_3 > 0$  everywhere. At  $x = 0$  we assume  $A(0, \tau)$  to be of the form of a soliton:

$$A(0, \tau) = a \operatorname{sech} \left\{ a \left( \frac{y_3^3}{2y_2} |p_1| \right)^{1/2} (\tau - \tau_0) \right\} \exp i \alpha (\tau + \phi) \quad (2-1)$$

We choose  $\alpha = 0$  (soliton with zero velocity) and without loss of generality take  $\tau_0 = \phi = 0$ . We want to study the effect of the depth variation and of the current on the propagation of the soliton. In particular we want to know what will become of the initial soliton in region 2. (An oscillatory signal decreasing as  $(x_2)^{-1/2}$ ? a soliton? a multisolitons?)

(a) The D-R theory.

In reference [5] Djordjevic and Redekopp studied analytically the problem of the evolution of a soliton moving over a slowly varying depth without current. To solve this problem they made very strong assumptions. We will check numerically if these assumptions are correct. Their work will be referred as the D-R theory.

Let us first explain the method they used and which needs no modification if there is a current.

If we write  $A(x_2, \tau) = \exp\left(-\int_0^{x_2(x)} y_1(u) du\right) P(x, \tau)$  where  $x = \int_0^{x_2} -y_2(u) du$

the equation for  $P(x, \tau)$  is:

$$iP_x + P_{\tau\tau} = -\frac{y_3(x_2)}{y_1(x_2)} \exp\left(-2\int_0^{x_2} y_1(u) du\right) |P|^2 P \quad (x_2 = x_2(x)) \quad (2-2)$$

In region 1 and 2 where the coefficients are constant the solution of this problem is related to the Zakharov Shabat eigen-value problem (cf Appendix B-C).

$$\begin{cases} u_\tau + i\lambda u - q_i v \\ v_\tau - i\lambda v = -q_i^* u \end{cases} \quad (2-3)$$

where  $q_i(\tau) = \left(\frac{1}{2} \frac{y_3}{y_2} \mid i\right)^{1/2} \exp\left(\int_0^{x_{2i}} y_1(u) du\right) P(x_{2i}, \tau)$  where  $\begin{cases} x_{21} = 0 \\ x_{22} = \epsilon^2 L \end{cases}$

At  $x = 0$   $A$  is a soliton  $\Rightarrow P = p_0 \operatorname{sech}(K\tau)$ .

Where

$$K = p_0 \left(\frac{1}{2} \frac{y_3}{y_2} \mid 1\right)^{1/2} \quad (2-4)$$

Djordjevik and Redekopp made the assumption that at  $x = L$   $P$  conserves its original shape.

$$P(\epsilon^2 L, \tau) = p_0 \operatorname{sech} K(\tau - \tau_0) \quad (2-5)$$

this assumption means that if in region (1)  $A = p_0 \operatorname{sech}\left(p_0\left(\frac{1}{2} \frac{y_3}{y_2} \mid 1\right)^{1/2} \tau\right)$

Then just after the transition

$$A = \exp\left(-\int_0^{x_2} y_1(u) du\right) p_0 \operatorname{sech}\left(p_0\left(\frac{1}{2} \frac{y_3}{y_2} \mid 1\right)^{1/2} (\tau - \tau_0)\right) \text{ at } x_2 = \epsilon^2 L \quad (2-6)$$



$$\text{i.e., } A(\varepsilon^2 L, \tau) = \left\{ \left( \frac{Cg}{\sigma} \mid_1 \right) \left( \frac{\sigma}{Cg} \mid_2 \right) \right\}^{1/2} p_0 \operatorname{sech} \left\{ p_0 \left( \frac{y_3}{2y_2} \mid_1 \right)^{1/2} (\tau - \tau_0) \right\} \quad (2-7)$$

It is easy to verify that this expression satisfies the first two evolution laws.

Let us introduce the following integral  $\mathcal{A}$ :

$$\mathcal{A} = \int_{-\infty}^{+\infty} |A(\varepsilon^2 L, \tau)|^2 d\tau \quad (2-8)$$

Since  $\int_{-\infty}^{+\infty} \frac{du}{\cosh u} = \pi$ , D-R theory (2-8) would give:

$$\mathcal{A} = \pi \left\{ \left( \frac{Cg}{\sigma} \mid_1 \right) \left( \frac{\sigma}{Cg} \mid_2 \right) \left( \frac{2y_2}{y_2} \mid_1 \right) \right\}^{1/2} \quad (2-9)$$

When  $q(\tau) = a \operatorname{sech} K(\tau - \tau_0)$  the Zakharov-Shabat eigen-value problem with potential  $q$  is exactly solvable (cf Appendix B and reference [19]). In particular the number of discrete eigen-values with positive real parts, i.e., the number of solitons which will emerge for  $x_2 \rightarrow \infty$ , is the largest integer smaller than  $\frac{a}{K} + \frac{1}{2}$ . If we assume that  $P(\varepsilon^2 L, \tau) = p_0 \operatorname{sech} K(\tau - \tau_0)$  then in region (2) the associated Zakharov-Shabat eigen-value problem has the potential:

$$\begin{aligned} q_2(\tau) &= \left( \frac{1}{2} \frac{y_3}{y_2} \mid_2 \right)^{1/2} \exp\left(-\int_0^{\varepsilon^2 L} y_1(u) du\right) p_0 \operatorname{sech} K(\tau - \tau_0) \\ &= p_0 \left\{ \frac{1}{2} \frac{y_3}{y_2} \mid_2 \left( \frac{Cg}{\sigma} \mid_1 \right) \left( \frac{\sigma}{Cg} \mid_2 \right) \right\}^{1/2} \operatorname{sech} K(\tau - \tau_0) = p_0' \operatorname{sech} K(\tau - \tau_0) \end{aligned} \quad (2-10)$$

$$K = p_0 \left( \frac{y_3}{2y_2} \mid_1 \right)^{1/2} \quad (\text{in region (1) we have a soliton})$$

The final number of soliton in region (2) will be

$$N = \text{largest integer} \left\{ \left( \frac{y_3}{y_2} \mid 2 \right) \left( \frac{y_2}{y_3} \mid 1 \right) \left( \frac{Cg}{\sigma} \mid 1 \right) \left( \frac{\sigma}{Cg} \mid 2 \right) \right\}^{1/2} + \frac{1}{2}$$

(2-11)

In the next section we shall use our computed results to check the assumption (2-5) of D-R theory.

(b) Numerical results: let us first discuss the few examples we have studied and then compare them with the prediction of the previous model.

Before giving the results it is important to notice that in all the numerical examples which are worked we have limited the dimensions of the matrix  $A(k,j)$  (cf section 1-3) such that  $I_{\max} \times J_{\max} \sim 1000$ . For this reason, and since we need sometimes a very fine discretization it is not possible to study the amplitude for very large  $x_2$ . So the plots are not always very easy to interpretate since the asymptotic state ( $x_2 \rightarrow +\infty$ ) is not obtained.

Let us also notice that the necessary fineness of the discretization, and so the length on which we solve the equation depends strongly on the physical parameters we choose. On all the plots the broad line shows the end of the region of depth variation.

• Discussion of the plots: we have taken as initial data:

$$A(0, \tau) = \frac{q}{\sqrt{y_3(0)}} \operatorname{sech} \left( \frac{q}{\sqrt{2y_2(0)}} \tau \right)$$

This is a soliton, with zero velocity, for region (1). We have plotted  $|A(x_2, \tau)|$  over the region of depth variation. Five cases have been

worked out:

i.  $U = 0$

--in Figure (9)  $T = 3$   $L = 0.5$   $q = 5$  and  $dh = -0.6$ . The soliton travels from deep to intermediate depth. We have studied  $A(x_2, \tau)$  for

$$\begin{cases} x_2 = 0 \text{ to } 0.5 \\ \tau = 0 \text{ to } 5 \end{cases}$$

The result is clearly the disintegration of the soliton. It is interesting to notice that as the depth decreases the profile becomes flatter and flatter. (In this example the relative error on the integral test (1-4) is 0.2%.)

-- in Figure(10)  $U = 0$   $L = 0.5$   $q = 5$   $T = 5$  and  $dh = 0.2$ . The soliton propagates in water of intermediate and increasing depth. The result is that the profile becomes more peaked as the depth increases. (Relative error on the integral test is 3%.)

-- in Figure (11)  $T = 5$   $L = 0.3$   $q = 5$  and  $dh = 0.2$ . The depth increases very fast. We have studied  $A(x_2, \tau)$  for

$$\begin{cases} x_2 = 0 \text{ to } 0.3 \\ \tau = 0 \text{ to } 5 \end{cases}$$

The characteristic form of the two-bounded solitons appears. (Relative error on the integral test is 5%.)

ii. in Figures (12), (13), (14)  $U = 0.4$   $T = 3$  and  $q = 2$ .

-- in Figure (12)  $L = 1$   $dh = -0.1$ . The soliton travels into decreasing depth. We studied  $A(x_2, \tau)$  for

$$\begin{cases} x_2 = 0 \text{ to } 5.6 \\ \tau = 0 \text{ to } 5 \end{cases}$$

The result as in Figure (9) is the disintegration of the soliton. (Relative error on the integral test is 0.04%.)

-- in Figure (13)  $L = 1$ .  $dh = 0.1$ . The soliton travels into

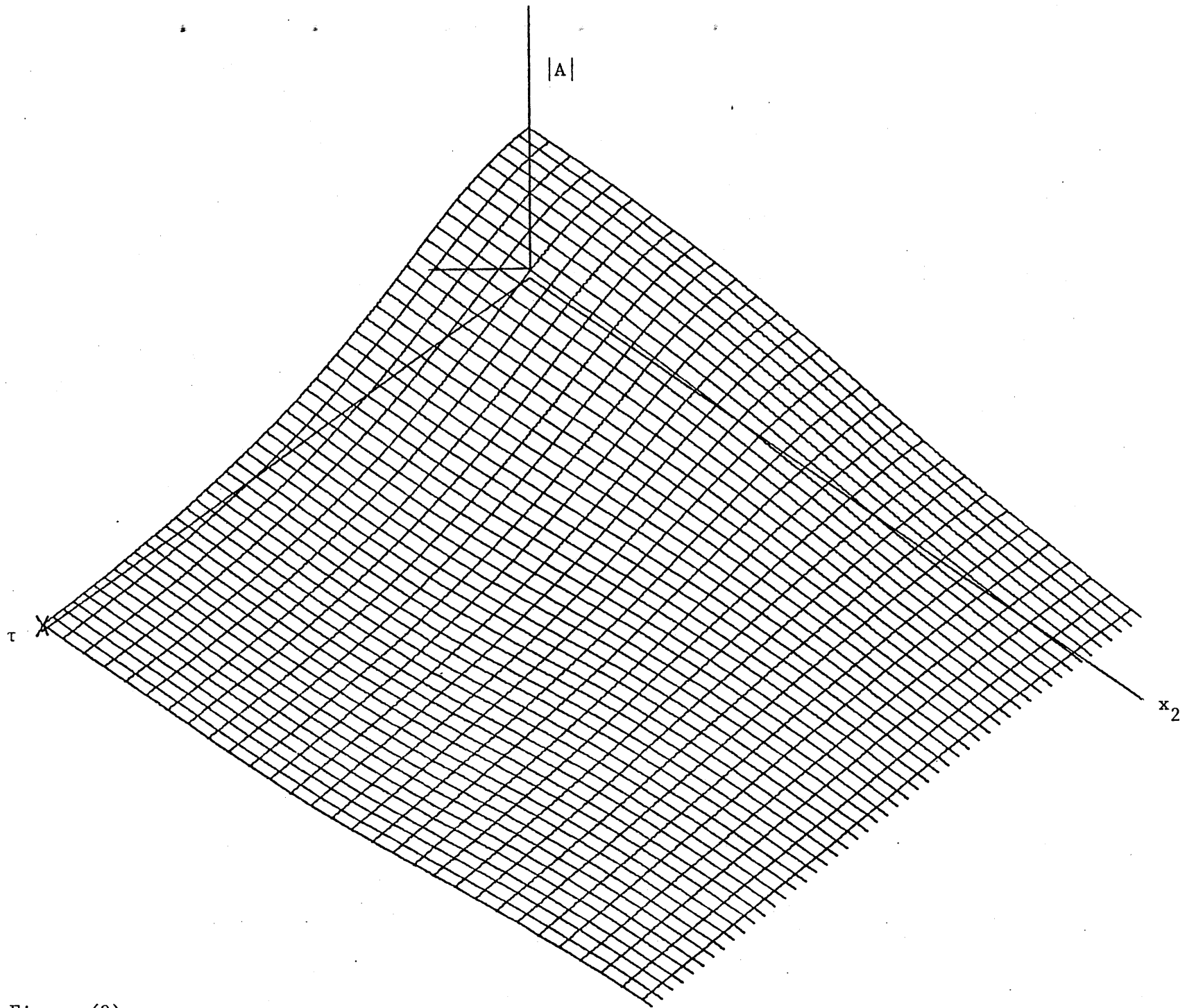

Figure (9)

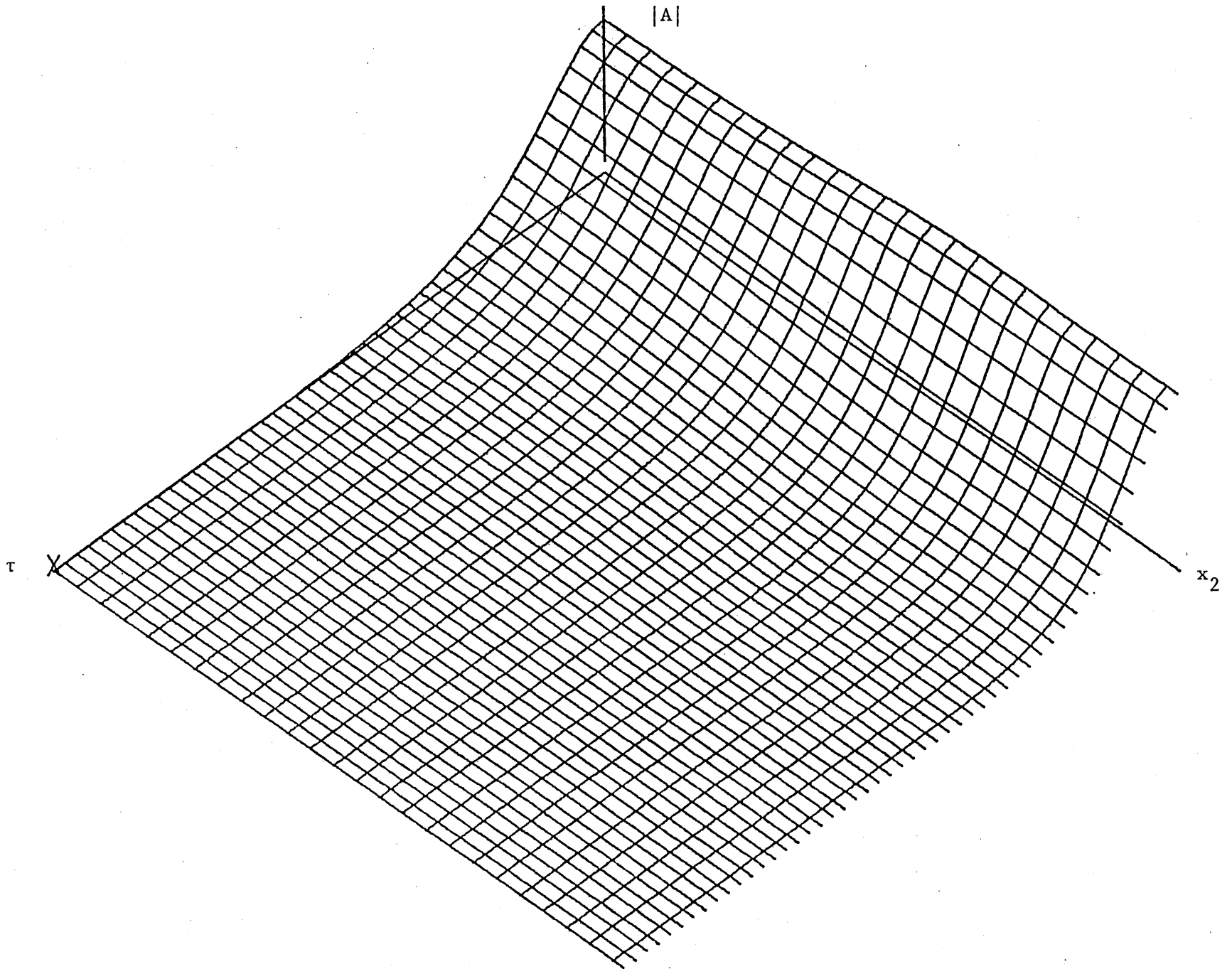

Figure (10)

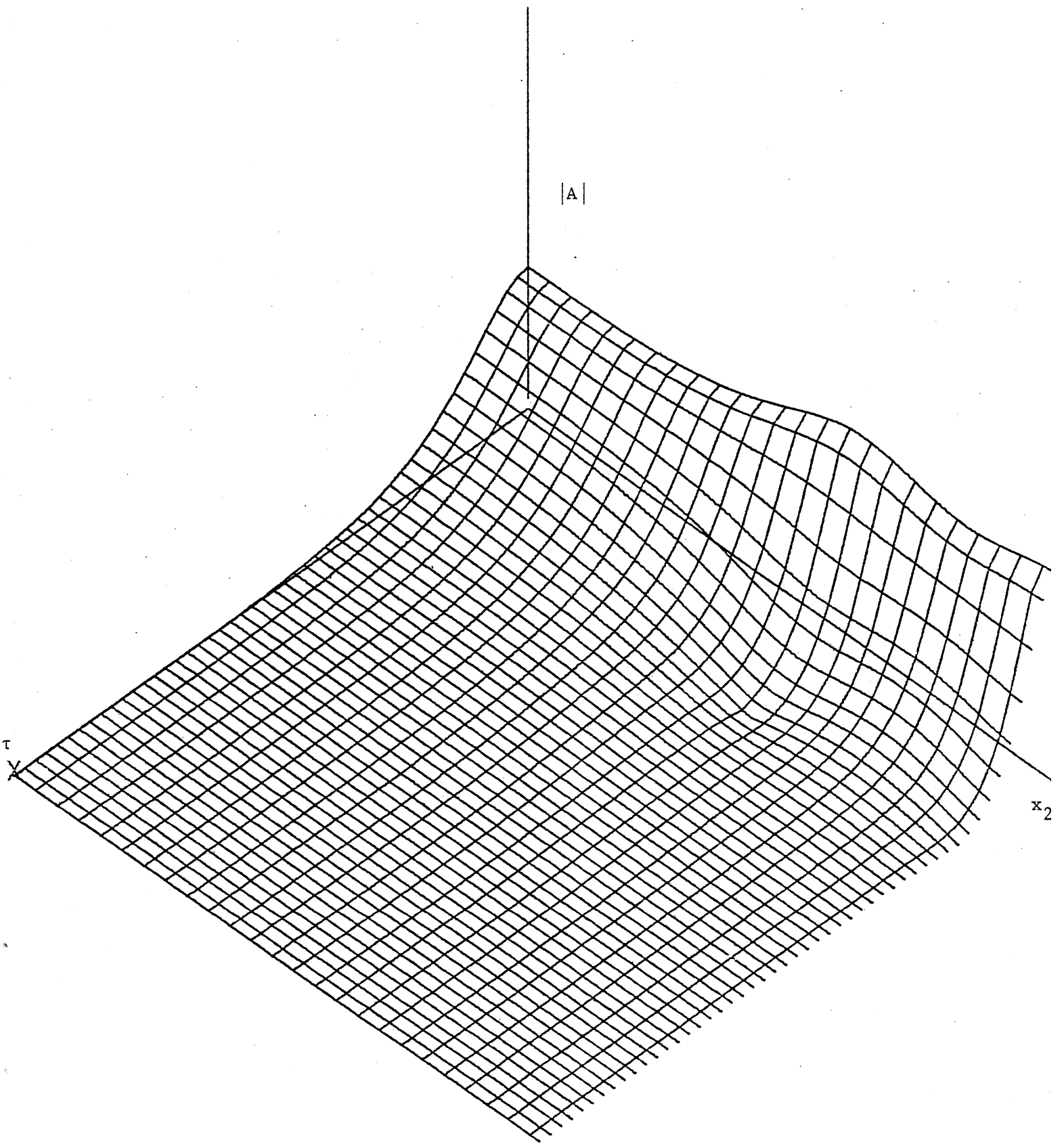

Figure (11)

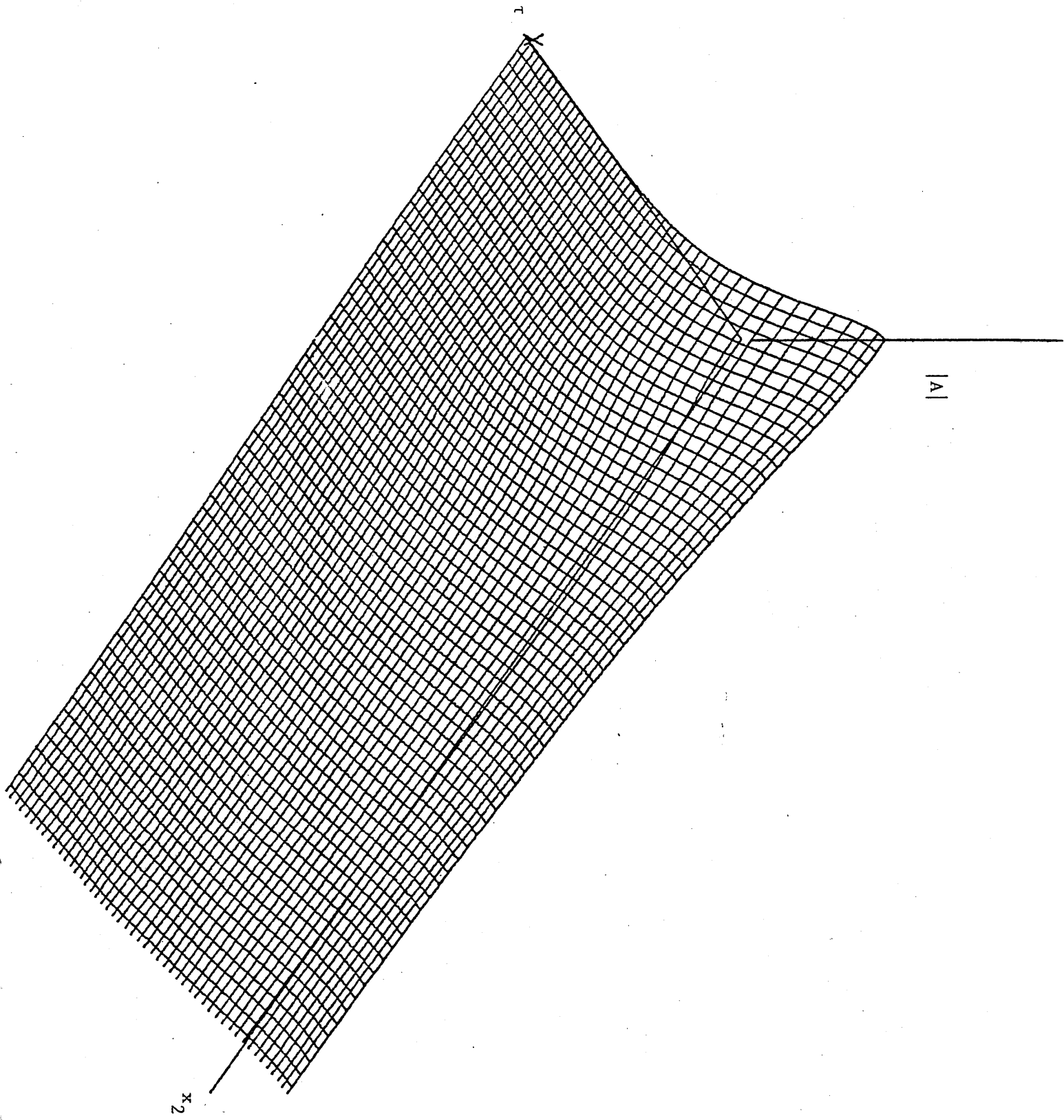

Figure (12)

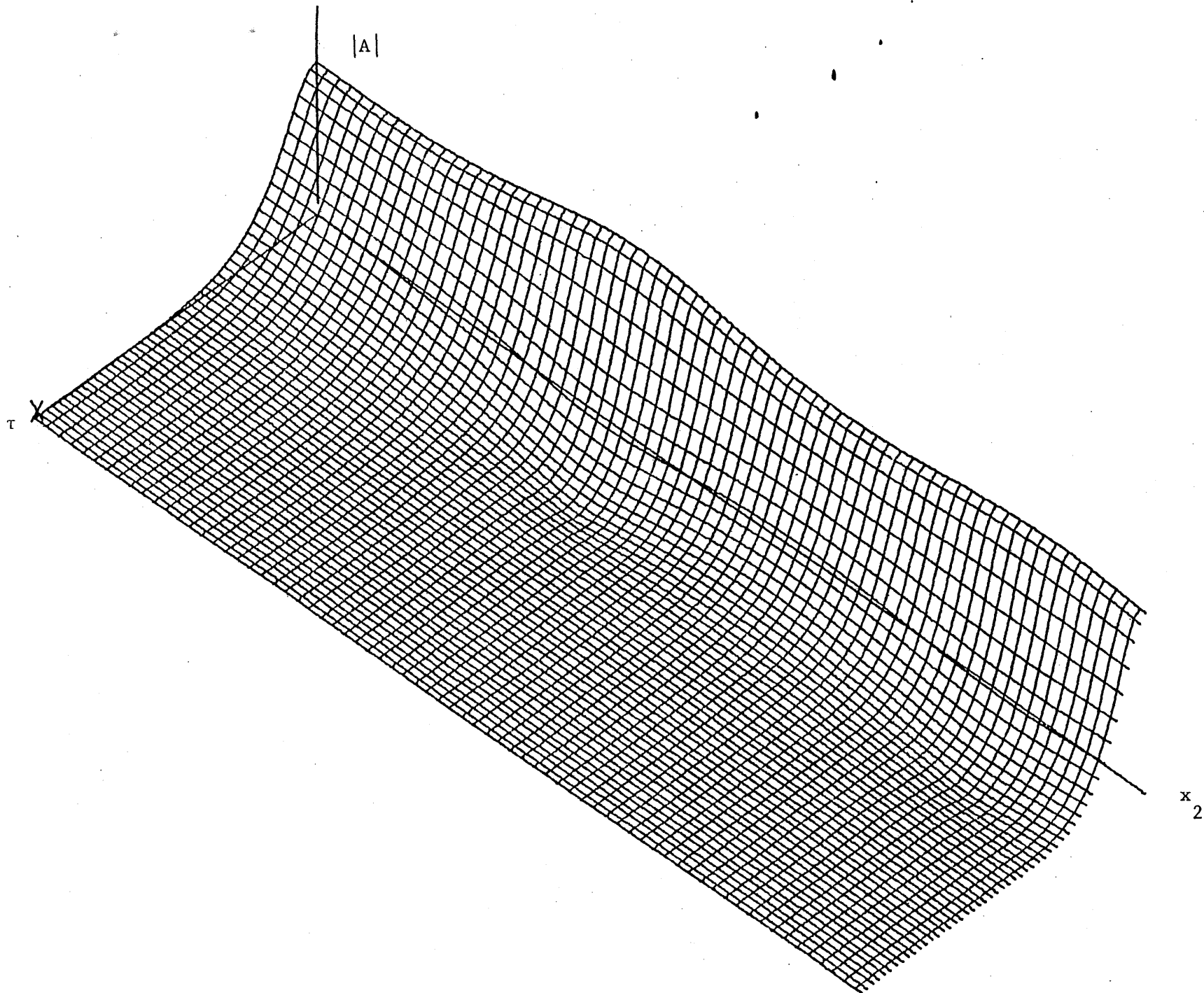

Figure (13)



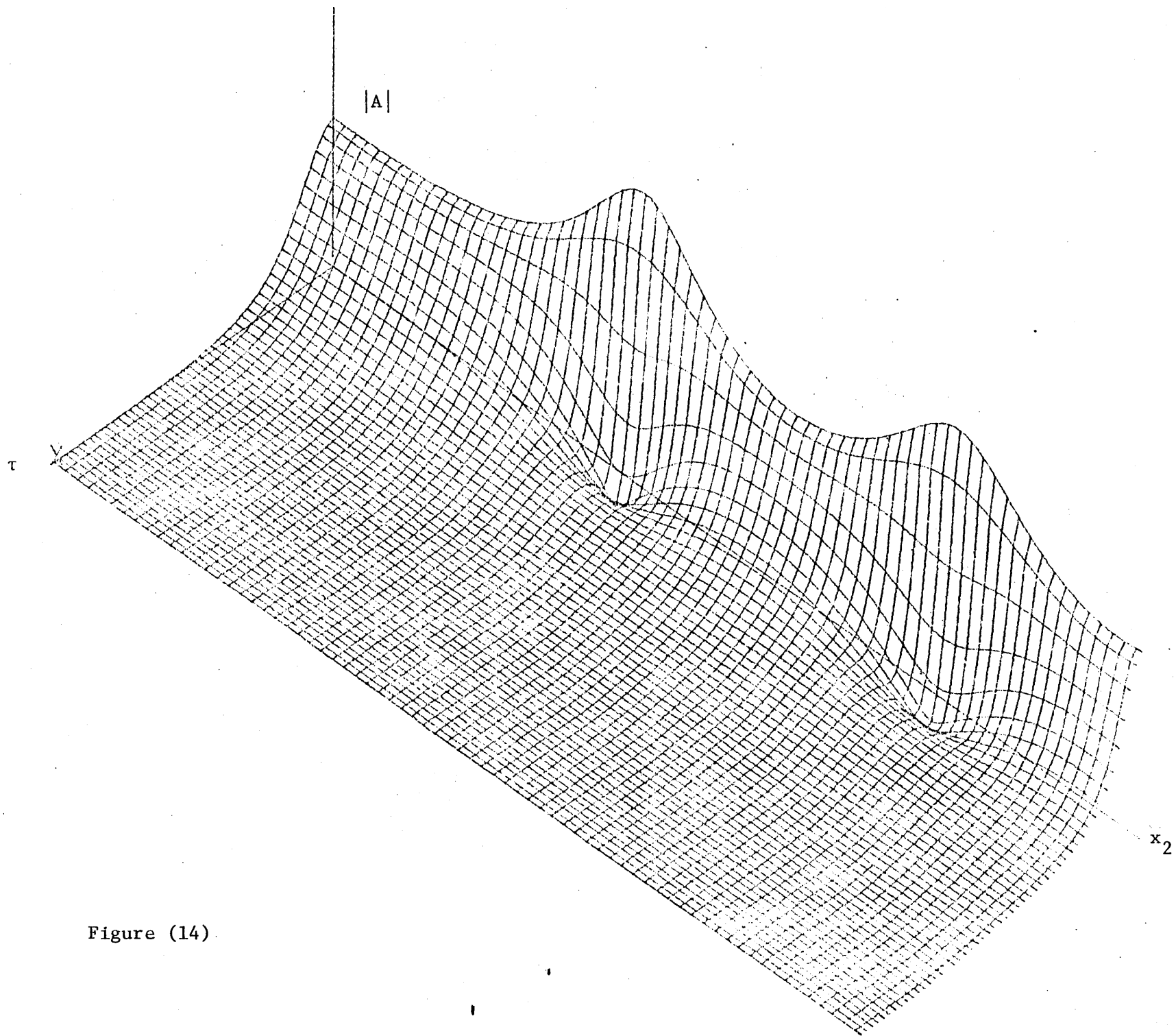

Figure (14)

increasing depth. We studied  $A(x_2, \tau)$  for

$$\begin{cases} x_2 = 0 \text{ to } 2.8 \\ \tau = 0 \text{ to } 5 \end{cases}$$

The result is as in Figure (10) that the profile becomes more peaked as the depth increases. A new soliton with parameters adapted to region (2) seems to emerge. (Relative error on the integral test is 0.64%.)

--in Figure (14)  $L = 0.3$   $dh = 0.5$ . The depth increases very rapidly We studied  $A(x_2, \tau)$  for

$$\begin{cases} x_2 = 0 \text{ to } 0.85 \\ \tau = 0 \text{ to } 5 \end{cases}$$

In this case the deformation of the initial soliton is very important. The characteristic shape of two-bounded solitons (cf Figure (5)) becomes apparent. (Relative error on the integral test is 1.7%.)

• Comparison with the model: we use two criteria to compare the numerical results with the prediction of the model explained in (a).

i. Comparison of the shape: the sech profile is not always a good approximation of the actual profile at the end of the region of depth variation. On Figure (14) in particular one can clearly see two peaks in the profile.

ii. Comparison of the area: it is easy to compare the numerical value of

$$A = \int_{-\infty}^{\infty} |A(x_2, \tau)| d\tau \quad \text{at the end of the region of depth variation}$$

with these given by formula (2-9). The results are the following:

		$A$ numerical	model (formula 2-9)	relative error %
U=0	T=3 dh=-0.6	30.65	18.70	-38%
	T=5 dh= 0.2	7.35	8.29	15%
U=0.4 T=3	dh=-0.1	3.52	3.162	-10%
	dh= 0.1	3.02	3.63	20%
	dh= 0.5	3.002	4.25	41%

Table (2)

In these results we have normalized  $A$  such that  $y_3(0) = 1$ .

The conclusion is clearly that the prediction of the model is not good, especially when the envelope at the top of the transition is not a single soliton.

### 2.2.2 Study of the fission of two-bounded solitons ( $y_2 y_3 > 0$ everywhere)

In this section we study the evolution of two -bounded solitons whose shape is given on Figure (5). The initial profile is:

$$A(0, \tau) = \frac{2}{\sqrt{y_3(0)}} \operatorname{sech} \frac{\tau}{\sqrt{2y_2(0)}} \quad \text{and } U = 0.4 \quad T = 3$$

-- in Figure (15)  $L = 1$   $dh = -0.1$  (the depth decreases). We studied  $A(x_2, \tau)$  for

$$\begin{cases} x_2 = 0 \text{ to } 2.85 \\ \tau = 0 \text{ to } 5 \end{cases}$$

The result is clearly the disintegration of the original solitons. (Relative error on the integral test is 0.1%.)

-- in Figure (16)  $L = 0.5$   $dh = 0.1$  (the depth increases). We studied  $A(x_2, \tau)$  for

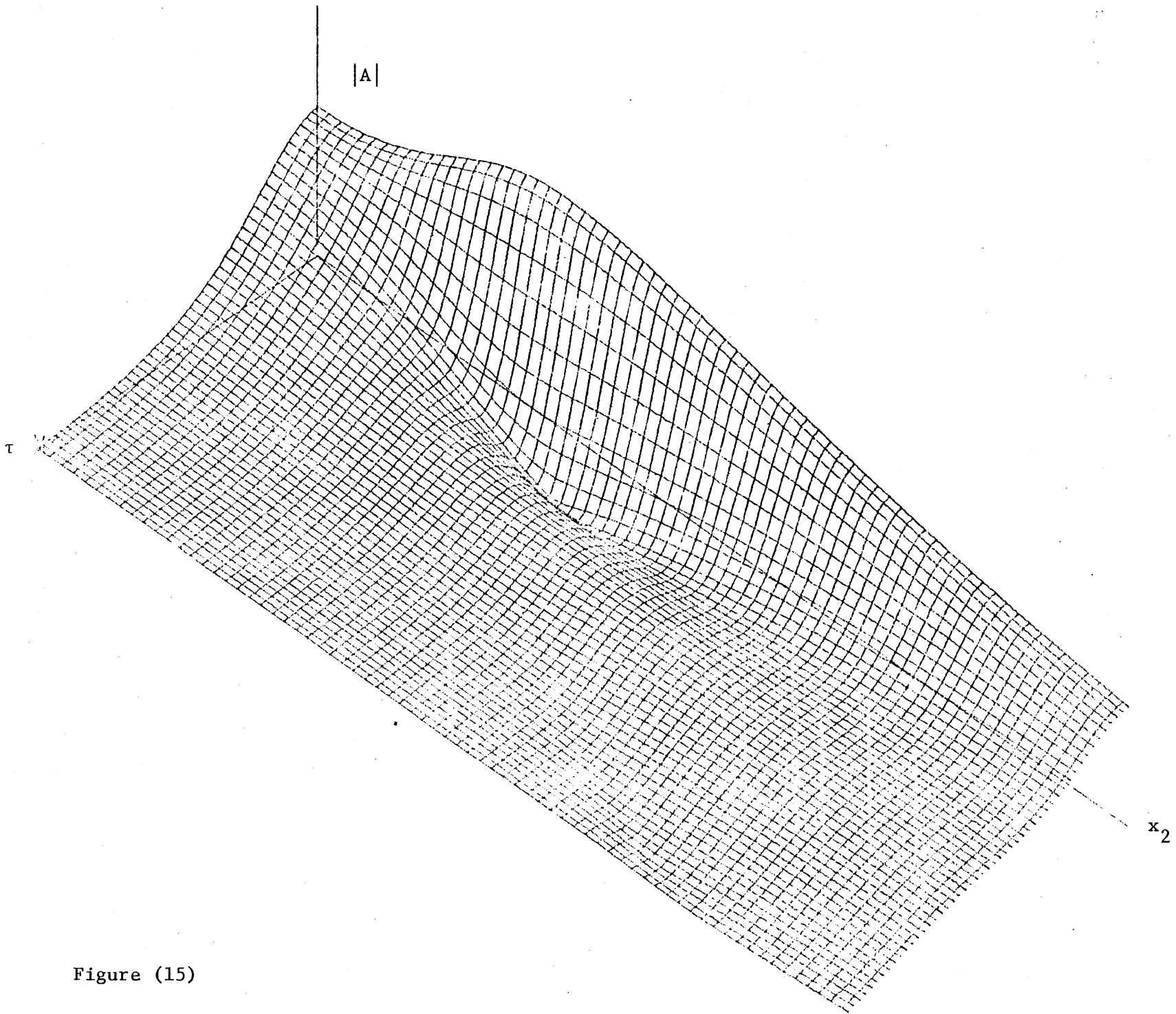

Figure (15)

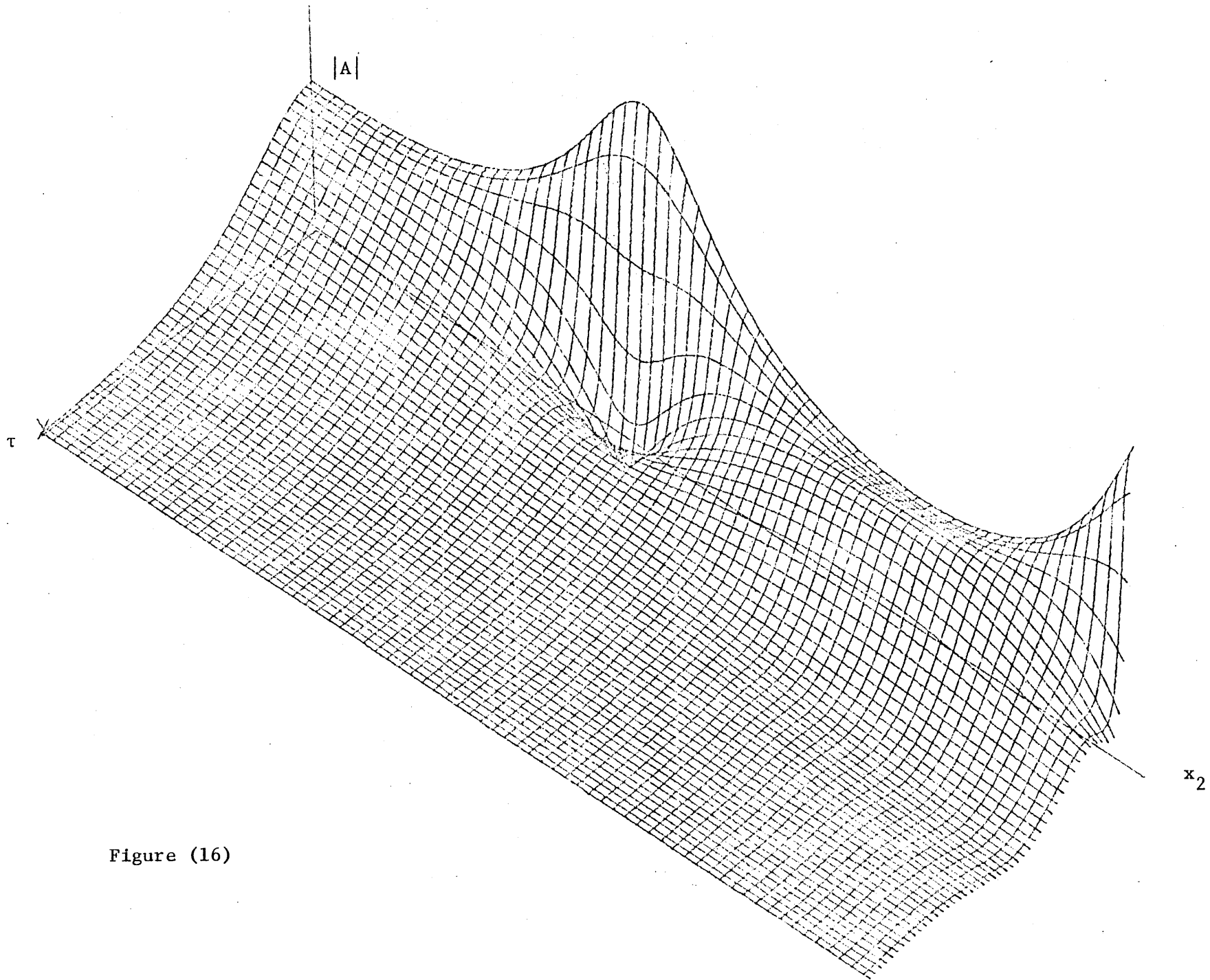

Figure (16)

$$\begin{cases} x_2 = 0 \text{ to } 1.42 \\ \tau = 0 \text{ to } 5 \end{cases}$$

The result is not easy to interpretate (we would have to solve for  $x_2$  much larger). It seems however that the initial two bounded solitons are conserved but the oscillatory tail may be of some importance. (Relative error on the integral test is 0.85%.)

### 2.2.3. Evolution of a sech profile when $y_2 y_3 < 0$ everywhere.

When  $y_2 y_3 < 0$  everywhere, if we impose  $A(x, \tau) \rightarrow 0$  as  $\tau \rightarrow \pm \infty$  we know that any initial profile  $A(x, \tau)$  will evolve into an oscillatory tail decreasing as  $\frac{1}{\sqrt{x_2}}$  as  $x_2 \rightarrow +\infty$ . This result is quite clear on Figure (15) (16).

In Figure (17) we have taken  $U = 1.6$   $T = 3$   $L = 1$ .  $dh = -0.2$ . The initial profile is

$$A(0, \tau) = \frac{2}{\sqrt{|y_3(0)|}} \operatorname{sech} \frac{\tau}{\sqrt{2y_2(0)}}$$

The envelope is studied for

$$\begin{cases} x_2 = 0 \text{ to } 1.83 \\ \tau = 0 \text{ to } 1 \end{cases}$$

In Figure (18) we have used the same values as in Figure (17) except  $T = 5$  and

$$A(0, \tau) = \frac{2}{\sqrt{|y_3(0)|}} \operatorname{sech} \frac{2\tau}{\sqrt{2y_2(0)}}$$

In both cases the integral check is exactly respected.

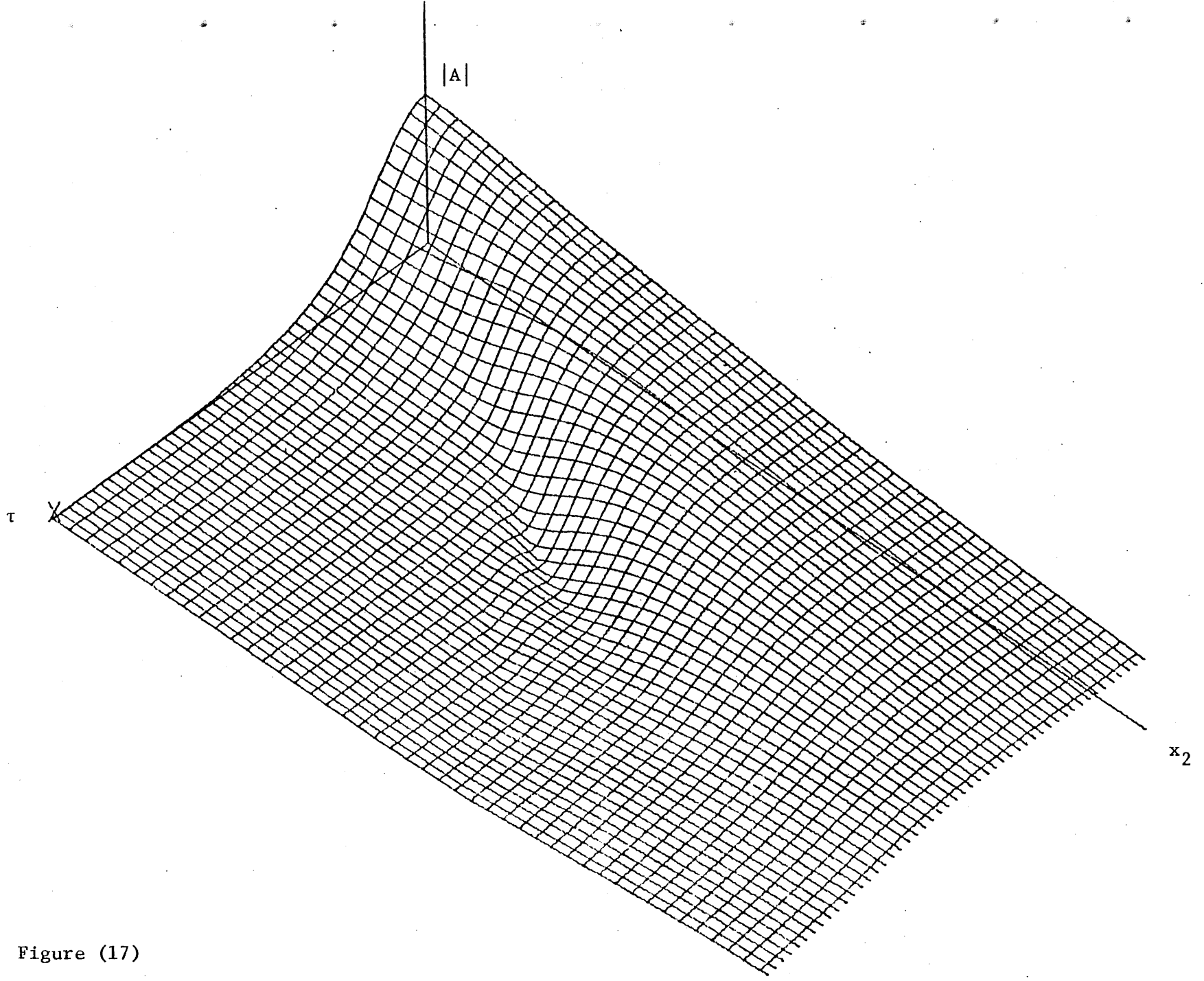

Figure (17)

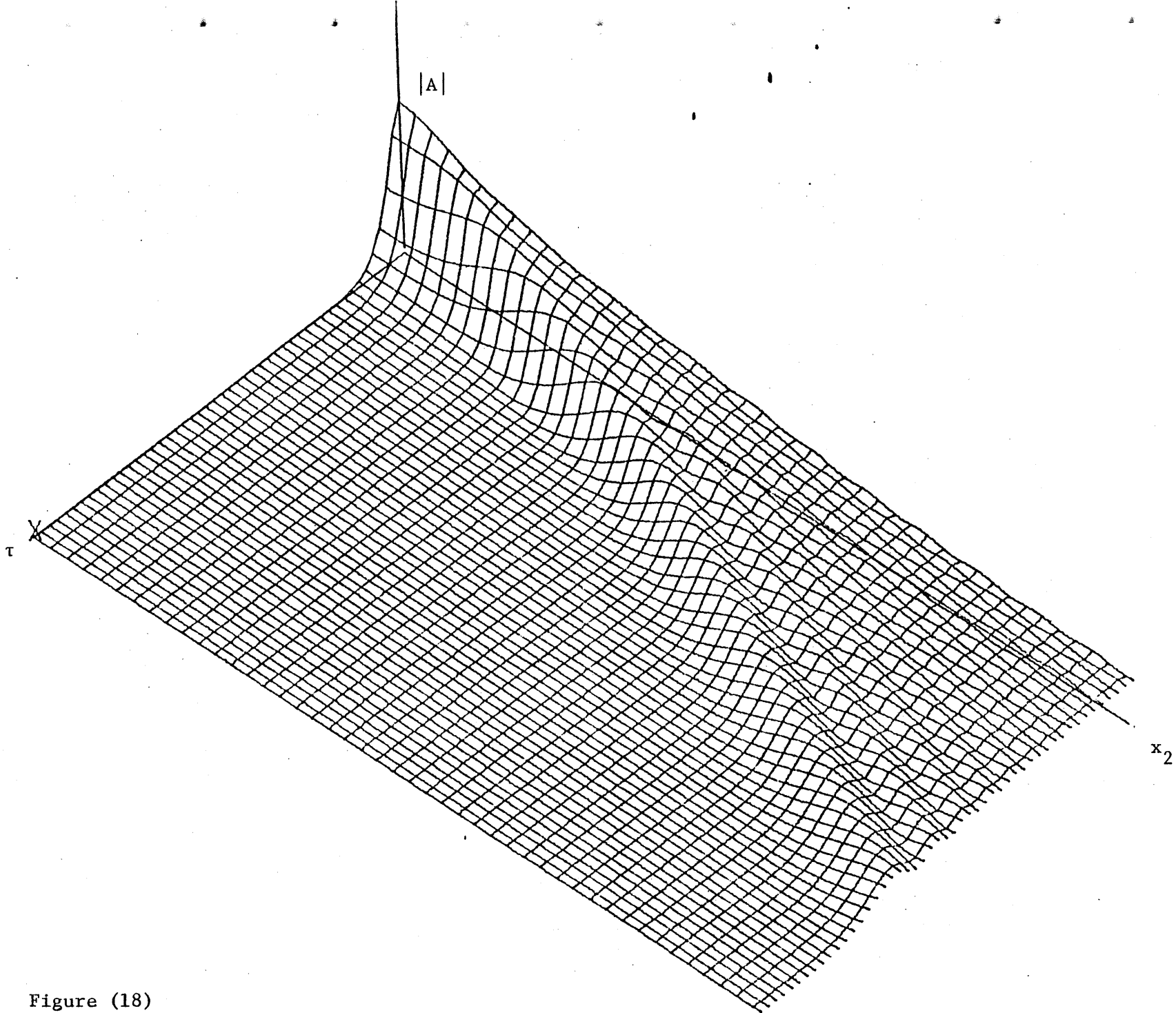

Figure (18)



### Conclusion of the study.

Some interesting features can be deduced from the previous plots. Let us first summarize them when  $y_2 y_3 > 0$  everywhere.

If the current  $U$  is smaller than 1 (in physical variable  $U < \sqrt{gH_1}$ ) it was pointed out in section (2-1) that for a given amplitude a soliton is flatter in shallow water than it is in deeper water. For this reason the following results could have been expected:

--The effect of increasing depth is to steepen any initial profile. Furthermore as it moves over a region of depth change, a soliton is transformed into a new soliton, more peaked with its parameters adapted to the new depth. If the depth change is sufficient the initial soliton can fission (see Figure (14) where two bounded solitons emerge after depth change).

--On the other hand the effect of decreasing depth is to flatten any initial profile. In this case a soliton disintegrates. This result is consistent with the fact that if the depth decreases sufficiently,  $y_3$  becomes negative and then, in region (2), any profile disintegrates, the final result being an oscillatory tail decreasing as  $\frac{1}{\sqrt{x_2}}$ .

If  $U$  is greater than 1, it was pointed out in section 2-1 that for a given amplitude a soliton is flatter in deep water than it is in shallow water. For this reason it is expected that in this case the effect of increasing depth is to flatten the initial profile and the effect of decreasing depth to steepen it. However, as can be seen on Table (2) in Appendix D, when  $U$  is greater than 1,  $y_3$  which decreases with increasing depth, can be positive and hence solitons can exist, only for very small period. (There is only one case where  $y_3$  is positive with  $U > 1$ , it is

when  $T = 1$  and  $h$  very near  $h_c$ , see Table (3).) For this reason we did not study this case.

When  $y_2 y_3$  is negative everywhere the numerical results show clearly the disintegration of any initial profile. This is predicted theoretically when the coefficients are constant; the fact that the depth varies does not affect qualitatively this behavior. We have checked numerically that this result holds even when  $y_3$  changes sign as the depth varies, provided that  $y_3$  is positive in region (1) and negative in region (2).

Another interesting feature is that, in all the examples studied, the velocity of the eventual solitons emerging in region (2) is always the same as these of the initial soliton, i.e., 0.

To conclude, let us remark that although the number of examples studied is limited, quite characteristic features appear: they show clearly the very drastic effect of current and depth change on the propagation of a wave packet. To have more decisive conclusions it seems necessary to study the amplitude of the waves on a much longer length, i.e.,  $x_2 \gg 1$ . Furthermore different initial profile should be tried and it would be of particular interest to study the effect of waves propagating against the current.

## REFERENCES

- [1] Ablowitz, M.J., Kaup, D.J., Newell, A.C., Segur, H. (1974) "The inverse scattering transform fourrier analysis for nonlinear problem," *Studies in App. Math.* 53, 4, 249.
- [2] Benjamin, T.B. and Feir, J.E. (1967) "The desintegration of waves trains on deep water" *Journ. Fluid Mech.* 27, 417.
- [3] Bretherton, F.P. and Garret, C.J.R. (1968) "Waves train in inhomogeneous moving media" *Proc. Roy. Soc. Serie A* 302, 529.
- [4] Chu, V.H. and Mei, C.C. (1970) "On slowly varying Stoke's waves" *Jour. Fluid Mech.* 41, 873.
- [5] Djordjevic, V.D. and Redekopp, L.G. (1978) "On the developement of packet of surface gravity waves moving over an uneven bottom" *ZAMP* 29, 950.
- [6] Gardner, C.S., Greene, J.M., Kruskal, M.D., and Miura, R.M. (1967) "Method for solving the Korteweg de Vries equation" *Phys. Nev. Lett.* 19, 1095.
- [7] Hasegawa, A., and Tappert, T.D. (1973) "Transmission of stationary nonlinear optical pulses in dispersive dielectric fibers" *II App. Phys. Letters* 23, 171.
- [8] Korteweg, D.J., and de Vries, G. (1895) "On the change of form of long waves advancing in a rectangular canal, and a new type of long stationary waves" *Phil. Mag.* 5, 39, 422.
- [9] Longuet-Higgins, M.S. and Stewart, R.W. (1960) "Changes in the form of short gravity waves on long waves and tidal current" *Jour. Fluid Mech.* 8, 565.
- [10] Longuet-Higgins, M.S. and Stewart, R.W. (1961) "The change in amplitude of short gravity waves on steady non-uniform currents" *Jour. Fluid Mech.* 10, 529.
- [11] Longuet-Higgins, M.S. and Stewart, R.W. (1964) "Radiation stress in water waves a physical discussion with applications" *Deep Sea Res.* 11, 529.
- [12] Mei, C.C., "Waves in the Sea--Dynamics and Engineering Applications" (to be published by Wiley Interscience).
- [13] Nayfey (1973) "Perturbation Methods" Wiley Intersciences, New York.
- [14] Ono, H (1972) "Waves propagation in an inhomogenous anharmonic lattice" *Jour. Phy. Society of Japan* 32, 332.

- [15] Ono, H. (1974) "Nonlinear waves modulation in inhomogeneous media" Jour. Phy. Society of Japan 37, 1668.
- [16] Peregrine, D.H. (1976) "Interaction of water waves and currents" Adv. Appl. Math. 16, 9.
- [17] Phillips, O.M. (1966) "The dynamic of the upper ocean" Cambridge University Press, London and New York.
- [18] Potter, D. (1973) "Computational Physics" Wiley Intersciences, New York.
- [19] Satsuma, J., and Yajima, N. (1973) "Initial value problems of one-dimensional self-modulation of nonlinear-dispersive waves" Suppl. of Prog. in Theor. Physics 55, 284.
- [20] Segur, H. (1976) "Asymptotic solutions and conservation laws for the cubic Schrödinger equation II" Jour. of Math. Physics 17, 5, 714.
- [21] Smith, R. (1976) "Giant waves" Jour. Fluid Mech. 77, 417.
- [22] Stokes, G.G. (1847) "On the theory of oscillating waves" Trans. Camb. Phil. Soc. 8, 441.
- [23] Whitham, G.B. (1962) "Mass momentum and energy flux in water waves" Jour. Fluid Mech. 12, 135
- [24] Whitham, G.B. (1965) "A general approach to linear and nonlinear dispersive waves using a Lograngian" Jour. Fluid Mech. 23, 273.
- [25] Whitham, G.B. (1967) "Variational methods and application to water waves" Proc. Roy. Soc. Ser. A 299, 6.
- [26] Whitham, G.B. (1974) "Linear nonlinear waves" Wiley Interscience, New York.
- [27] Yue, D.K. (1980) Numerical study of Stoke's waves diffraction at grazing incidence" Ph.D. Thesis, MIT.
- [28] Zakharov, V.E., and Shabat, A.B. (1972) "Exact theory of two dimensional self-focusing and one-dimensional self-modulation of waves in nonlinear media" Sov. Phys. JETP 34, 62
- [29] Zakharov, V.E. and Shabat, A.B. (1973) "Interaction between solitons in a stable medium" Sov. Phys. JETP 37, 823.

Appendix A: Condition for a steady current over variable depth.

We showed (in I-3-2) that  $X = \frac{\zeta + h}{H_1}$  = dimensionless total depth in

presence of a current is, if it exists, the solution of the cubic equation:

$$X^3 - (h + \frac{U_1^2}{2}) X^2 + \frac{U_1^2}{2} = 0$$

which is continuous and approaches 1 as  $h \rightarrow 1$ .

• Let us write the equation in the following form:

$$X^3 - (1 + a^2)X^2 + a^2 = (\frac{h}{H_1} - 1)X^2 \quad \text{where } a^2 = \frac{U_1^2}{2}$$

The left hand side has the root 1; it can be written as:

$$\begin{aligned} \text{L.H.S} &= (X - 1)(X - X_2)(X - X_1) \\ \left\{ \begin{aligned} X_1 &= \frac{a^2 - \sqrt{a^4 + 2a^2}}{2} < 0 \\ X_2 &= \frac{a^2 + \sqrt{a^4 + 2a^2}}{2} > 0 \end{aligned} \right. \end{aligned}$$

It is easy to show that

$$\left\{ \begin{aligned} X_2 > 1 &\Leftrightarrow U_1 > 1 \\ X_2 < 1 &\Leftrightarrow U_1 < 1 \end{aligned} \right.$$

if  $U_1 = 1$  then  $X_2 = 1$

As  $U$  is adimensionalized by  $\sqrt{gH_1}$  the critical value is  $\sqrt{gH_1}$  in physical variables.

It is then easy to see what can be the different cases:

(1)  $U_1 > 1$

a<sup>o</sup>)  $h > H_1$

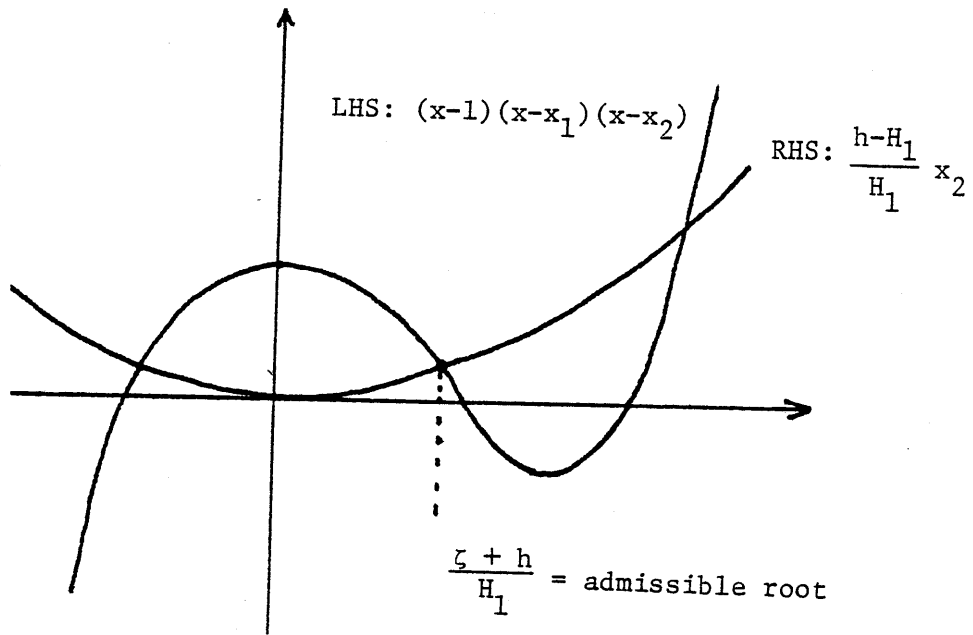

b<sup>o</sup>)  $h < H_1$

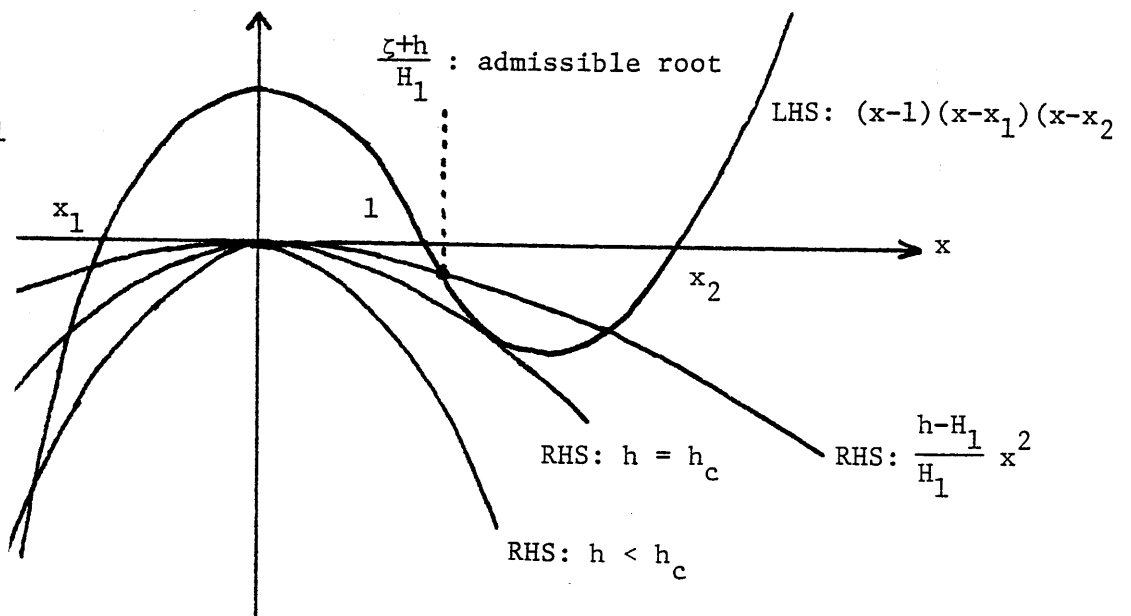

It is obvious that for  $a^2$  fixed there is a critical depth  $h_c$  for which, if  $h < h_c$  there is no root which possessed the desired properties.

(2) If  $U_1 < 1$  the figure is of the same kind but  $x_2 < 1$ . Here also if  $h < H_1$   $h$  must be, for  $a^2$  fixed such that  $h > h_c$ .

(3) If  $U_1 = 1$  then  $x_2 = 1$  and  $h_c = 1$ ; if  $h < H_1$  there is obviously no solution:

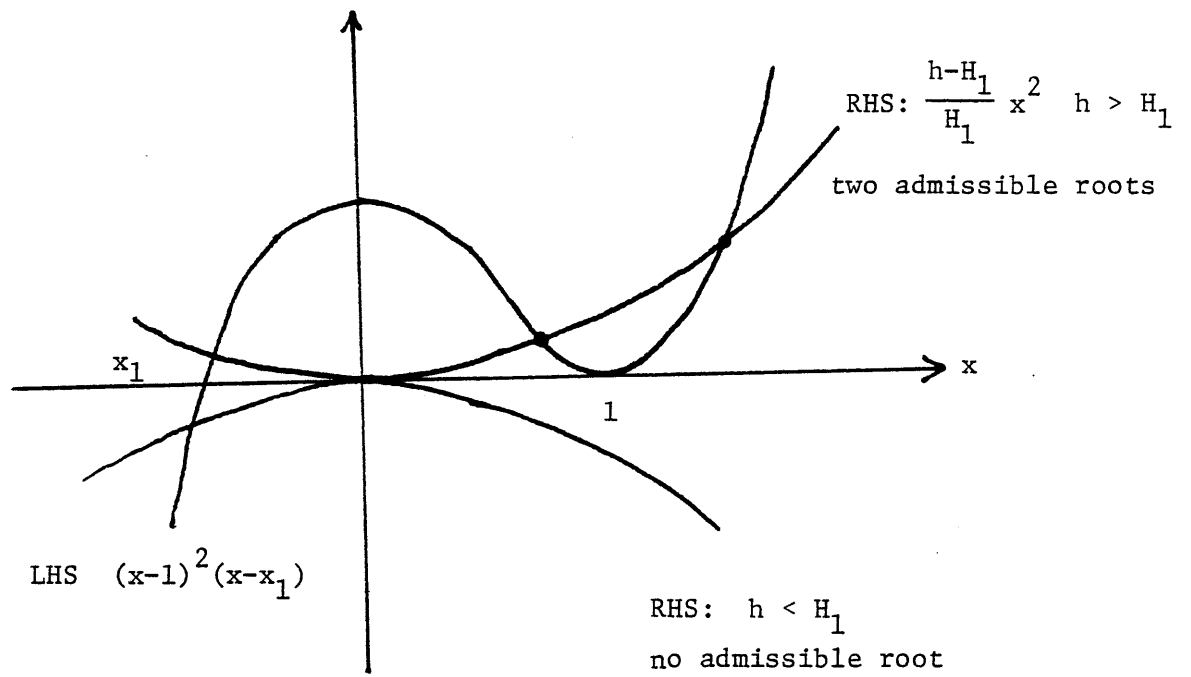

• Let us find  $hc$ :

we study the case  $h > 0$  everywhere; the equation for  $x$  is then

$$y(x) = x^3 - (a^2 + b^2)x^2 + a^2 = 0$$

$$\begin{cases} a^2 = \frac{U_1^2}{2} \\ b^2 = \frac{h}{H_1} \end{cases}$$

$$y'(x) = 0 \iff \begin{cases} x = 0 & y(0) = a^2 > 0 \\ x = \frac{2}{3}(a^2 + b^2) & > 0 \end{cases}$$

all depends on the sign of  $y(\frac{2}{3}(a^2 + b^2)) = y_1$  indeed

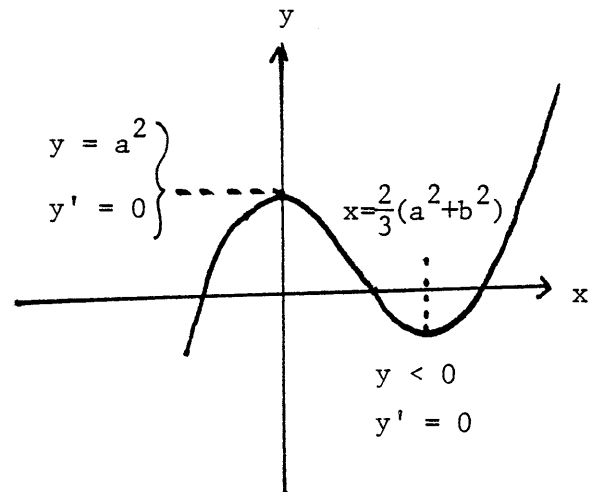
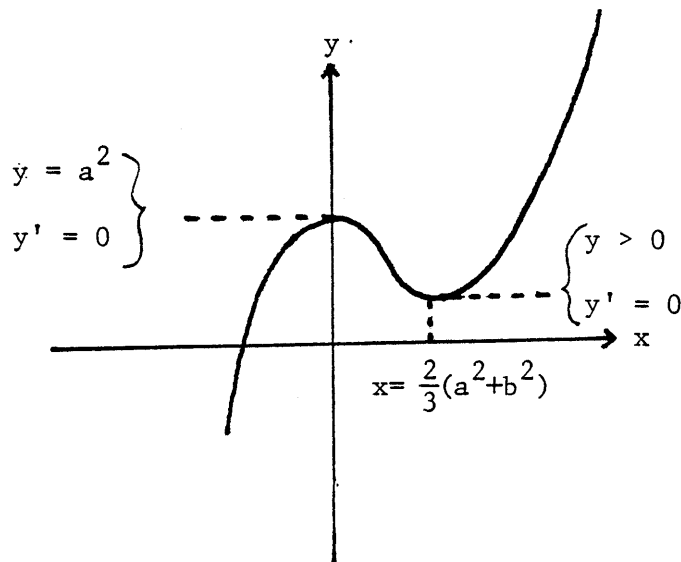

we want to have  $y(\frac{2}{3}(a^2 + b^2)) < 0$ .

It is easy to show that  $hc$  is given by the equation

$$y(\frac{2}{3}(a^2 + b^2)) = 0 \Leftrightarrow a^2 - \frac{4}{27}(a^2 + b^2)^3 = 0$$

$$\Leftrightarrow b^2 = \frac{hc}{H_1} = \sqrt[3]{\frac{27a^2}{4}} - a^2$$

$$\Rightarrow \frac{hc}{H_1} = 3 \sqrt[3]{\frac{U_1^2}{8}} - \frac{U_1^2}{2}$$



Appendix B: Inverse Scattering Theory for C.S.E.

In this Appendix we explain how the Inverse Scattering Theory (IST) is used to solve the cubic Schrödinger equation:

$$iu_t + u_{xx} + \chi |u|^2 u = 0 \quad \text{where } \chi = \text{constant} > 0 \quad (\text{B-1a})$$

For later convenience we transform this equation by taking  $v = \sqrt{\frac{\chi}{2}} u$ ;

the equation for  $v$  is then:

$$iv_t + v_{xx} + 2 |v|^2 v = 0 \quad (\text{B-1b})$$

When the depth is constant equation (I-2-43) can be reduced to equation (B-1a) if  $y_2 y_3 > 0$ ; by using the following transformation:

$$\begin{cases} x_2 = -t \\ \tau = \sqrt{y_2} x \\ A = \sqrt{\frac{2}{y_3}} v \end{cases}$$

We shall briefly explain at the end of this section what the differences are when  $\chi < 0$  (which correspond to  $y_2 y_3 < 0$ ).

The papers on which this section is based are: Zakharov and Shabat references [29] when  $\chi > 0$  and [30] when  $\chi < 0$ , and Ablowitz, et al., reference [1].

(a) Principle of the method: Ablowitz et al., showed that IST can be considered as the generalization for nonlinear problems of the method using fourrier transform to solve linear PDE. Let us therefore first recall some of the features of the fourrier transform method for the following linear PDE with inital conditions:

$$\begin{cases} \frac{\partial u(x,t)}{\partial t} = -i\omega(-i\frac{\partial}{\partial x}) u(x,t) \\ u(x,0) = f(x) \end{cases} \quad (\text{B-2})$$

$\omega(k)$  is the dispersion relation.

To solve problem (B-2) we take the fourrier transform in  $x$  of  $u(x,t)$ :

$$\hat{u}(k,t) = \int_{-\infty}^{+\infty} u(x,t) e^{-ikx} dx \quad (\text{B-3})$$

From  $\hat{u}(x,0)$  we know  $\hat{u}(k,0)$

$$\hat{u}(k,0) = \int_{-\infty}^{+\infty} f(x) e^{-ikx} dx \quad (\text{B-4})$$

By using equation (1-12) it is easy to see that  $\hat{u}$  is the solution of the problem:

$$\begin{cases} \frac{\hat{u}(k,t)}{t} = -i\omega(k) \hat{u}(k,t) \\ \hat{u}(k,0) = \hat{f}(k) \end{cases} \quad (\text{B-5})$$

As  $k$  appears as a parameter in (1-15) it is easy to solve for  $\hat{u}(k,t)$ .

$u(x,t)$  is then obtained by the inverse fourrier transform theorem:

$$u(x,t) = \frac{1}{2\pi} \int_{-\infty}^{+\infty} \hat{u}(k,t) e^{ikx} dk \quad (\text{B-6})$$

The problem is then solved. Let us summarize the three steps of the method.

- i. We map at each time  $u(x,t)$  to its fourrier transform  $\hat{u}(k,t)$ . As we know  $u(x,0)$ , we know  $\hat{u}(k,0)$ .
- ii. Knowing the equation governing  $u(x,t)$  we deduce the equation governing  $\hat{u}(k,t)$ . This equation must then be solved for  $\hat{u}(k,t)$ .

iii. At any time  $t$  we have only to invert the mapping process of step i.

The IST proceeds exactly like this to solve a nonlinear PDE but the mapping process is much less obvious: instead of mapping  $u(x,t)$  into its fourrier transform we have to associate the equation to an eigen-value problem depending on the unknown function  $u(x,t)$  and in which the time  $t$  plays the role of a parameter. Since we know  $u(x,0)$ , we can solve this eigen-value problem at  $t = 0$ . In fact we do not need to have the complete solution of the associated eigen value problem at  $t = 0$  but only some information on this solution. The information is contained in the so-called scattering data. This step which corresponds to step i. in the linear problem is called the direct scattering problem.

The procedure is then the same as in the linear problem: knowing the scattering data at  $t = 0$  we use the equation governing  $u(x,t)$  to enable us to follow the scattering data in  $t$ . This corresponds to step ii. The crux of the method is to find the proper eigen-value problem for which this process is possible.

The last step corresponding to iii. is how to deduce  $u(x,t)$  from the scattering data at  $t$ . This is the so-called inverse scattering problem. According to the inverse scattering problem it is sufficient to have the scattering data for the reconstruction of  $u(x,t)$ . (Exactly as in the linear theory: to reconstruct  $u(x,t)$  it is sufficient to know its fourrier transform.)

Before being more precise let us make two remarks:

Remark 1: The parallelism between the IST and fourrier transform methods is not only a parallelism in the procedure. Ablowitz et al.

showed [1] that in the linear limit, i.e., when  $u(x,t)$  is small in a certain sense (when  $u \ll 1$  the nonlinear equation  $iu_t + u_{xx} + \chi|u|^2 u = 0$  reduces to  $iu_t + u_{xx} \approx 0$ ) all the formulas of IST reduce to fourrier transform formulas.

Remark 2: The difficult and crucial step is to find the associated eigen-value problem for which, knowing the equation governing  $u$ , it is possible to follow the scattering data in  $t$ . Till now there is no systematic way to find the associated eigen value problem for a given nonlinear equation. This has been done to a large extent by guessing.

(b) application to the cubic Schrödinger equation:

The problem to be solved is:

$$\begin{cases} iu_t + u_{xx} + 2|u|^2 u = 0 & (1) \\ u(x,0) = f(x) & (2) \\ u(x,t) \text{ and all its derivatives vanish as } x \rightarrow \pm \infty & (3) \end{cases} \quad (\text{B-7})$$

• The mapping process: direct scattering problem.

Let us associate with equation (B-7) the following eigen-value problem for  $v_1(x,t)$  and  $v_2(x,t)$

$$\begin{cases} v_{1x} + i\zeta v_1 = u(x,t)v_2 \\ v_{2x} - i\zeta v_2 = -u^*(x,t)v_1 \end{cases} \quad (\text{B-8a})$$

which can be written in the following form:

$$Lv = \zeta v \text{ where } L = \begin{pmatrix} i \frac{\partial}{\partial x} & -iu \\ -iu^* & -i \frac{\partial}{\partial x} \end{pmatrix} \text{ and } v = \begin{pmatrix} v_1 \\ v_2 \end{pmatrix} \quad (\text{B-8b})$$

In this problem  $\zeta$  may be considered as a parameter;  $t$  appears also as a

parameter;  $u(x,t)$  which is the unknown solution of (B-7) is called the potential of the eigen-value problem which we shall call the Zakharov-Shabat eigen-value problem. Regarding (B-8) the following results hold (see Appendix c for proof):

Theorem 1: if  $u$  satisfies  $\int_{-\infty}^{+\infty} |u(x,t)| dx < +\infty$  (so it satisfies

in particular B-7(3)) then:

i. If  $\zeta$  is real there exist 4 solutions to problem (B-8)

$$\phi = \begin{bmatrix} \phi_1 \\ \phi_2 \end{bmatrix} \quad \bar{\phi} = \begin{bmatrix} \phi_2^* \\ -\phi_1^* \end{bmatrix} \quad \psi = \begin{bmatrix} \psi_1 \\ \psi_2 \end{bmatrix} \quad \bar{\psi} = \begin{bmatrix} \psi_2^* \\ -\psi_1^* \end{bmatrix} \quad \text{which have the}$$

following asymptotic behavior

$$\begin{cases} \phi \sim \begin{pmatrix} 1 \\ 0 \end{pmatrix} e^{-i\zeta x} & \text{and } \bar{\phi} \sim \begin{pmatrix} 0 \\ -1 \end{pmatrix} e^{i\zeta x} & \text{as } x \rightarrow -\infty \\ \psi \sim \begin{pmatrix} 0 \\ 1 \end{pmatrix} e^{i\zeta x} & \text{and } \bar{\psi} \sim \begin{pmatrix} 1 \\ 0 \end{pmatrix} e^{-i\zeta x} & \text{as } x \rightarrow +\infty \end{cases} \quad (\text{B-9})$$

(All these solutions are function of  $x$  and depend on  $\zeta$  and  $t$  as parameters:  $f(x;\zeta,t)$ )

These solutions are the Jost functions of the problem.

Furthermore it is easy to show that  $(\phi, \bar{\phi})$  and  $(\psi, \bar{\psi})$  form 2 sets of independent solutions. As one linear system of 2 equations of first order admits only 2 independent solutions we must have:

$$\begin{cases} \phi(x;\zeta,t) = a(\zeta,t) \bar{\psi}(x;\zeta,t) + b(\zeta,t) \psi(x;\zeta,t) \\ \bar{\phi} = -\bar{a} \psi + \bar{b} \bar{\psi} \end{cases} \quad (\text{B-10})$$

we say that  $\zeta \in \mathbb{R}$  is an eigen value belonging to the continuous spectrum

ii. If  $\zeta$  is complex and  $\text{Im}\zeta > 0$  it is still possible to define

$\phi$  and  $\psi$  as solutions of (B-8) satisfying (B-9). Furthermore  $\lim_{x \rightarrow +\infty} e^{i\zeta x} \phi(x)$

exists. We define  $a(\zeta, t)$  for  $\text{Im}\zeta > 0$  by this limit. In view of (B-9)  $a(\zeta, t)$  is just a transmission coefficient.  $\phi, \psi$  and  $a$  are analytic functions for  $\text{Im}\zeta > 0$ . So  $a(\zeta, t)$  has a finite number of zeros with  $\text{Im}\zeta > 0$ . These zeros  $\zeta_k$   $k = 1, \dots, N$  are called the discrete eigenvalues. Also, if  $\zeta = \zeta_k$  then  $\psi(x; \zeta_k, t)$  and  $\phi(x; \zeta_k, t)$  are dependent, i.e., there exists  $b_k(t)$  such that  $\phi = b_k \psi$ .

The solution  $\phi$  is called a bound state. In general  $b(\zeta, t)$  is not defined for  $\zeta$  complex so we can not write  $b_k = b(\zeta_k, t)$ . However, if  $u$  satisfies more stringent conditions as  $x \rightarrow \pm \infty$  (for instance  $u(x, t)$  has a compact support) then it is possible to define  $b$  for  $\zeta$  complex. In this case  $b_k(t) = b(\zeta_k, t)$ .

We now explain what we mean by scattering data.

Definition: the scattering of data of problem (B-8) are  $a(\zeta, t)$  for  $\zeta$  in the upper half plane, i.e.,  $\text{Im}\zeta \geq 0$ ,  $b(\zeta, t)$  (for  $\zeta$  real),  $\zeta_j$ ,  $b_j(t)$  (for  $j = 1, \dots, N$ )

The first step of the method is then: knowing  $u(x, 0)$  find the scattering data at  $t = 0$ . This step is obviously much more difficult than in the linear case where we had only to take the fourrier transform of the inital data  $u(x, 0)$ ; the Zakharov Shabat eigen-value problem (B-8) is exactly solvable only for very few potentials  $u(x, 0) = f(x)$ . Among these potentials, one which is particularly interesting is  $u(x, 0) = A \text{sech } x$ . This case is studied in detail in reference [19]. But even when (B-8) is not exactly solvable the method provides a lot of qualitative results.

• Evolution of the scattering data with  $t$ :

The next step is to follow the scattering data with  $t$ . This is possible because we have chosen (B-8) especially for that. The following results hold (see Appendix C for proof).

Theorem 2: if  $u(x,t)$  satisfies equation (B-7(1)) (+ conditions as  $x \rightarrow \pm \infty$ ) the scattering data of problem (B-8) have the following properties:

i.  $\zeta_j$  is independent of time, i.e., if  $\zeta = \zeta_j$  is a discrete eigen value at time  $t_1$  then it is also one at any time.

ii.

$$\begin{cases} a(\zeta, t) = a(\zeta, 0) \\ b(\zeta, t) = b(\zeta, 0) \exp(4i\zeta^2 t) \\ b_j(t) = b_j(0) \exp(4i\zeta_j^2 t) \end{cases} \quad (\text{B-11})$$

The equivalent of step ii. is then achieved.

• The inverse scattering problem:

The last step is: knowing the scattering data at  $t$  by (B-11), find  $u(x,t)$  the potential which creates these scattering data. This is a highly mathematical problem involving integration in the complex plane. The following results hold: (see Appendix C for proof).

Theorem 3: If the scattering data for (B-8) are  $a(\zeta, t)$  (for  $\zeta$  in the upper half plane)  $b(\zeta, t)$  (for  $\zeta$  real),  $\zeta_j$  and  $b_j(t)$  ( $j = 1, \dots, N$ ) then the potential  $u(x,t)$  of B-8) is obtained as follows:

i. Solve the following system of  $2N + 2$  linear integral equations for  $\psi_1(x; \zeta, t)$ ,  $\psi_2(x; \zeta, t)$  for  $\zeta$  real,  $\psi_1(x; \zeta_k, t)$   $\psi_2(x; \zeta_k, t)$   $k = 1, \dots, N$ :

$$\begin{aligned}
 \psi_2^*(x; \zeta_k, t) e^{i\zeta_k^* x} &= 1 + \frac{1}{2i\pi} \int_{-\infty}^{+\infty} \frac{d\zeta' b(\zeta', t)}{a(\zeta', t)(\zeta' - \zeta_k^*)} \psi_1(x; \zeta', t) e^{i\zeta' x} - \sum_{j=1}^N \frac{b_j(t)}{a'(\zeta_j, t)} \frac{\psi_1(x; \zeta_j, t) e^{i\zeta_j x}}{(\zeta_j - \zeta_k^*)} \\
 \psi_1(x; \zeta_k, t) e^{-i\zeta_k x} &= \frac{1}{2\pi i} \int_{-\infty}^{+\infty} \frac{d\zeta' b^*(\zeta', t)}{a^*(\zeta', t)(\zeta' - \zeta_k)} \psi_2^*(x; \zeta', t) e^{-i\zeta' x} - \sum_{j=1}^N \frac{b_j^*(t)}{a'^*(\zeta_j, t)} \frac{\psi_2^*(x; \zeta_j, t) e^{-i\zeta_j^* x}}{(\zeta_k - \zeta_j^*)}
 \end{aligned}
 \quad \left. \vphantom{\begin{aligned} \psi_2^* \\ \psi_1 \end{aligned}} \right\} k = 1, \dots, N$$

$$\begin{aligned}
 \psi_2^*(x; \zeta, t) e^{i\zeta x} &= 1 + \frac{1}{2\pi i} \oint_{-\infty}^{+\infty} \frac{d\zeta' b(\zeta', t) \psi_1(x; \zeta', t) e^{i\zeta' x}}{a(\zeta', t)(\zeta' - \zeta)} - \frac{1}{2} \frac{b(\zeta, t)}{a(\zeta, t)} \psi_1(x; \zeta, t) e^{i\zeta x} \\
 &- \sum_{k=1}^N \frac{b_k(t)}{a'(\zeta_k, t)} \frac{\psi_1(x; \zeta_k, t) e^{i\zeta_k x}}{(\zeta_k - \zeta)}
 \end{aligned}$$

for  $\zeta$  real

In all these equation  $x$  and  $t$  may be considered as parameters.

(B-12)  
continued on next page

We use the following notations:  $\cdot f^*$  = complex conjugate

$\cdot \oint_{-\infty}^{+\infty}$  = principal value of the integral

$a' = \frac{da}{d\zeta}$  ( $a$  is an analytic function in the upper half plane)



(B-12) continued

$$\begin{aligned} \psi_1(x; \zeta, t) e^{-i\zeta x} &= \frac{1}{2\pi i} \int_{-\infty}^{+\infty} \frac{d\zeta' b^*(\zeta', t) \psi_2^*(x; \zeta', t) e^{i\zeta' x}}{a^*(\zeta', t) (\zeta' - \zeta)} + \frac{1}{2} \frac{b^*(\zeta)}{a^*(\zeta)} \psi_2^*(x; \zeta, t) e^{i\zeta x} \\ &+ \sum_{k=1}^N \frac{b_k^*(t)}{a_k^*(\zeta_k, t)} \frac{\psi_2^*(x; \zeta_k, t)}{(\zeta_k^* - \zeta)} e^{-i\zeta_k^* x} \end{aligned} \quad \text{for } \zeta \text{ real}$$

In all these equations  $x$  and  $t$  may be considered as parameters.

We use the following notations:

- $f^*$  = complex conjugate
- $\int_{-\infty}^{+\infty}$  = principal value of the integral
- $a' = \frac{da}{d\zeta}$  ( $a$  is an analytic function in the upper half plane)

ii.  $u(x,t)$  is then given by:

$$u(x,t) = -2i \sum_{k=1}^N \frac{b_k^*(t) e^{-i\zeta_k^* x}}{a^*(\zeta_k, t)} \psi_2^*(x; \zeta_k, t) - \frac{1}{\pi} \int_{-\infty}^{+\infty} d\zeta' \frac{b^*(\zeta', t)}{a^*(\zeta', t)} \psi_2^*(x; \zeta', t) e^{-i\zeta' x} \quad (\text{B-13})$$

By simply taking fourrier transform with respect to  $\zeta$  of equations (B-12) it is possible to give another formulation of the inverse scattering problem using integral equations of Marshenko type (both formulations have their advantages).

Theorem 3 bis: If we know the scattering data  $a(\zeta, t)$  (for  $\zeta$  in the upper half plane),  $b(\zeta, t)$  (for  $\zeta$  real)  $\zeta_j$ ,  $b_j(t)$  ( $j = 1, \dots, N$ ) we obtain the potential  $u(x,t)$  of B-8) by:

i. Solving the 2 integral equations of Marchenko type for  $K_1(x,y,t)$ ,  $K_2(x,y,t)$ :

$$\left. \begin{aligned} \text{(a)} \quad K_1(x,y,t) &= F^*(x+y,t) + \int_x^{+\infty} K_2^*(x,s,t) F^*(x+y,t) ds \\ \text{(b)} \quad K_2^*(x,y,t) &= - \int_x^{+\infty} K_1(x,s,t) F(x+y,t) ds \end{aligned} \right\} \text{for } y > x \quad (\text{B-14})$$

where the kernel of these equations  $(x,t)$  is:

$$F(x,t) = -i \sum_{k=1}^N \frac{b_k(t)}{a(\zeta_k, t)} e^{i\zeta_k x} + \frac{1}{2\pi} \int_{-\infty}^{+\infty} \frac{b(\zeta, t)}{a(\zeta, t)} e^{i\zeta x} d\zeta \quad (\text{B-15})$$

ii. then  $u(x,t)$  is given by:

$$u(x,t) = -2K_1(x,x, t) \quad (\text{B-16})$$

Let us make two comments on these results:

i. They hold when the  $\zeta_k$  are simple zeros of  $a(\zeta)$  (i.e.,  $a'(\zeta_k) \neq 0$ ) and when  $a(\zeta) \neq 0$  for  $\zeta$  real.  $\Rightarrow$  all the discrete eigen values have a non-zero (positive) imaginary part.

ii. To solve the inverse scattering problem it is sufficient to know:  $a(\zeta, t)$ ,  $b(\zeta, t)$  (for  $\zeta$  real),  $\zeta_k$ ,  $a'(\zeta_k, t)$   $b_k(t)$  (for  $k = 1, \dots, N$ )  
At this point it may seem that we have not really made any progress: we have only reduced the original nonlinear PDE to two nontrivial linear problems. We shall show in the next section how to use theorem 2 and 2 bis to study the solution of our problem.

(c) Study of the solution by using IST:

• Soliton and multisoliton solution.

If the initial data  $f(x)$  is such that at  $t = 0$  the scattering data satisfy  $b(\zeta, 0) = 0$  for  $\zeta$  real then by using (B-11)  $b(\zeta, t) = 0$  for any  $t$ . The equations of inverse scattering (B-12) and (B-13) reduce to a linear system of  $2N$  equations.

$$\left\{ \begin{array}{l} \psi_1(x; \zeta_j, t) e^{-i\zeta_j x} + \sum_{k=1}^N \frac{b_k^*(t)}{a'^*(\zeta_k, t)} \frac{\psi_2^*(x; \zeta_k, t)}{(\zeta_j - \zeta_k^*)} e^{-i\zeta_k^* x} = 0 \quad j = 1, \dots, N \\ \psi_2^*(x; \zeta_j, t) e^{i\zeta_j^* x} + \sum_{k=1}^N \frac{b_k(t)}{a'(\zeta_k, t)} \frac{\psi_1(x; \zeta_j, t)}{(\zeta_k - \zeta_j^*)} e^{i\zeta_k x} = 1 \quad j = 1, \dots, N \end{array} \right. \quad (B-17)$$

$$u(x, t) = -2i \sum_{k=1}^N \frac{b_k^*(t)}{a'^*(\zeta_k, t)} \psi_2^*(x; \zeta_k, t) e^{-i\zeta_k^* x} \quad (B-18)$$

in which we have:

$$\begin{cases} b_k(t) = b_k(0) \exp 4i\zeta^2 t \\ a(\zeta, t) = a(\zeta, 0) \end{cases}$$

We get  $\psi_1(\zeta, t)$  and  $\psi_2(\zeta, t)$  for  $\zeta$  real by B-12 c and d. But these informations are useless in our problem.

i. One soliton solution: It is the particular case when  $f(x)$  is such that there is only one discrete eigen value ( $n = 1$ )  $\zeta_0 = \lambda_0 + i\eta_0$  where  $\eta_0 > 0$ .

The system (B-17) becomes:

$$\begin{cases} e^{-i\zeta_0 x} \psi_1(x; \zeta_0, t) + \frac{b_0^*(0)}{a'(\zeta_0, 0)} e^{-i(\zeta_0^* x + 4\zeta_0^{*2} t)} \frac{\psi_2^*(x; \zeta_0, t)}{2i\eta_0} = 0 \\ e^{i\zeta_0^* x} \psi_2^*(x; \zeta_0, t) + \frac{b_0(0)}{a'(\zeta_0, 0)} e^{i(\zeta_0 x + 4\zeta_0^2 t)} \frac{\psi_1(x; \zeta_0, t)}{2i\eta_0} = 1 \end{cases} \quad (\text{B-19})$$

$$u(x, t) = -2i \frac{b_0^*(0)}{a'(\zeta_0, 0)} e^{-i(\zeta_0^* x + 4\zeta_0^{*2} t)} \psi_2^*(x; \zeta_0, t)$$

It is just a matter of elementary algebra to check that the solution is:

$$u(x, t) = 2\eta_0 \frac{\exp \left\{ -4i(\lambda_0^2 - \eta_0^2)t - 2i\lambda_0 x + i\phi \right\}}{\cosh 2\eta_0(x - x_0 + 4\lambda_0 t)} \quad (\text{B-20})$$

where

$$x_0 = \frac{1}{2\eta_0} \ln \frac{|\lambda_0|^2}{2\eta_0} \quad \phi = -2 \arg \chi_0 \quad (\text{B-21})$$

$$\chi_0 = \sqrt{\frac{b_0(0)}{a(\zeta_0, 0)}}$$

(B-20) represents a soliton (cf II-(1-4)) of amplitude  $2 \operatorname{Im} \zeta_0$  and speed  $4 \operatorname{Re} \zeta_0$  where  $\zeta_0$  is the only discrete eigen value of the Zakharov Shabat eigen-value problem.

ii. N soliton solutions: when  $u(x,0)$  is such that there are N different eigen values in the upper half plane  $\zeta_1 = \lambda_1 + i\eta_1 \neq \zeta_2 \neq \dots \neq \zeta_N = \lambda_N + i\eta_N$ , we must consider system (B-17) (B-18). The study of this system does not present major difficulties but it is particularly tedious. All the details are given in reference [29] in which it is proved in particular that system (B-17) is not degenerate so that it has a unique solution. If the exact form of the solution which can be expressed by using determinants, is not easy to interpretate, the asymptotic form of the solution can be worked out relatively easily:

-- If all the eigen-values have different real parts  $\lambda_i$  an observer moving at the velocity  $-4 \lambda_i$  will see:

$\left\{ \begin{array}{l} \text{as } t \rightarrow -\infty \text{ one individual soliton of amplitude } \eta_i \text{ with parameter} \\ \lambda_i, x_0, \phi \\ \text{as } t \rightarrow +\infty \text{ the same soliton but with phase parameters } x_0', \phi' \end{array} \right.$

As  $t \rightarrow -\infty$  there are N solitons, the slowest is at the front, the fastest at the rear; as  $t \rightarrow +\infty$  there are still N solitons but now the slowest is at the rear, the fastest at the front. For each soliton the effect of the interaction is a change of phase  $\phi$  and origin  $x_0$ . One important feature is that this interaction is only a pair wise interaction: the final result of the interaction of one soliton with all the others is found by considering the sum of the phase and origin shift for all the interaction between pairs of solitons.

-- If all the eigen values have the same real part then the solitons

will not separate. We have bounded solitons. It can be easily shown by considering the expression of the solution in its determinant form that the bounded solitons contain, in time, all the frequencies  $\omega_g = 4(\eta_i^2 - \eta_j^2)$ .

• Oscillatory tail: When the initial data  $f(x)$  is such that there is no discrete eigen values, it is easier to study the solution with the Marchenko equations (B-16) to (B-18). In this case (B-17) becomes

$$f(x,t) = \frac{1}{2\pi} \int_{-\infty}^{+\infty} \frac{b(\zeta,t)}{a(\zeta,t)} e^{i\zeta x} d\zeta \quad (B-22)$$

by using (B-16b), (B-16a) becomes

$$K_1(x,y,t) = F^*(x+y,t) - \int_x^{+\infty} \int_x^{+\infty} K_1(x,u,t) F(y+u,t) F^*(s+y,t) du ds \quad (B-23)$$

As  $\frac{b(\zeta,t)}{a(\zeta,t)} = \frac{b(\zeta,0)}{a(\zeta,0)} \exp 4i\zeta^2 t$  (B-24) becomes

$$\begin{cases} F(x,t) = \frac{1}{2\pi} \int_{-\infty}^{+\infty} \frac{b(\zeta,0)}{a(\zeta,0)} e^{ig(\zeta)} d\zeta \\ g(\zeta) = 4\zeta^2 t + \zeta x \end{cases} \quad (B-24)$$

For large  $t$  this integral can be studied by the method of stationary phase by considering what will be seen by an observer moving at the velocity  $c$ . Once an asymptotic approximation of  $F$  is found one can find an approximate solution of (B-23) for large  $t$ . The algebra is very lengthy but the result is, qualitatively, quite simple:

$$u(x,t) \sim 0(|t|^{-1/2}) \text{ as } t \rightarrow \pm \infty$$

The contribution from the continuous spectrum is very different from that of the discrete spectrum, and is similar, for large time to the classical results obtained in linear theory, for the long time evolution of a

wave packet (cf for instance reference [12] chapter 2).

• For more general initial data  $b(\zeta, 0) \neq 0$  for  $\zeta$  real and there are some discrete eigen values. The problem is much more complicated and has been less studied. One can find for instance in reference [20] the detailed asymptotic study of the case where there is only one discrete eigen value. The expected result is that, for large time, an observer will see:

i. an oscillatory tail decreasing as  $O(|t|^{-1/2})$

ii. If he travels at the velocity of one soliton, i.e., if he travels at the velocity  $-4\lambda_j$  where  $\zeta_j = \lambda_j + i\eta_j$  is one discrete eigen value of problem (B-8) he will see a soliton of amplitude  $2\eta_j$ .

(d) Some remarks on the case  $\chi < 0$

In this case (cf Appendix C) the associated eigen-value problem we have to consider is:

$$\begin{cases} v_{1x} + i\zeta v_1 = u(x,t) v_2 \\ v_{2x} - i\zeta v_2 = u^*(x,t) v_1 \end{cases} \quad (\text{B-25a})$$

or

$$\tilde{L}v = \zeta v \quad \text{where } v = \begin{pmatrix} v_1 \\ v_2 \end{pmatrix} \quad \tilde{L} = \begin{pmatrix} i \frac{\partial}{\partial x} & -iu \\ iu^* & i \frac{\partial}{\partial x} \end{pmatrix} \quad (\text{B-25b})$$

If we look for solutions which vanish sufficiently fast as  $t \rightarrow \pm \infty$ , all the previous method can be applied with some minor changes due to the fact that we have  $u^*$  instead of  $-u^*$  in (B-8). The fundamental difference is that problem (B-25) is self-adjoint, so it does not admit complex eigen-values. As the solitons are associated with discrete eigen-values with positive imaginary parts, they cannot exist in this case. The important

consequence is that, if we impose  $u(x,t) \rightarrow 0$  as  $t \rightarrow \pm \infty$ , any initial data  $u(x,0) = f(x)$  will, for large  $t$ , evolve into an oscillatory tail decreasing as  $O(|t|^{-1/2})$  without any solitons.

However, using the fact that when  $\chi < 0$  permanent waves (Stoke's waves) are stable, Zakharov and Shabat studied this case with different boundary conditions as  $t \rightarrow \pm \infty$ : they take  $|u(x,t)| \rightarrow \text{constant}$  as  $t \rightarrow \pm \infty$ . In this case, (B-25) is still the right eigen-value problem to consider, the direct and inverse scattering problems are totally modified. The results are however qualitatively the same as when  $\chi > 0$  but the soliton is now replaced by the envelope hole soliton whose expression is given in Part II (1-9).



Appendix C: Proof of Theorems 1, 2, 3 of Appendix B

Proof of theorem 1:

To simplify the notations we do not write explicitly the dependence on  $t$  and  $\zeta$ . We consider system (B-8)

$$\begin{cases} v_{1x} + i\zeta v_1 = u v_2 \\ v_{2x} - i\zeta v_2 = -u^* v_1 \end{cases}$$

and assume  $\int_{-\infty}^{+\infty} |u(x)| dx < +\infty$  (C-1)

Let us consider for  $\text{Im}\zeta \geq 0$   $M(x,y) = -u^*(y) \int_y^x e^{2i\zeta(z-y)} u(z) dz$  (C-2)

All the results of the inverse scattering problem are consequences of the following lemma.

Lemma: If  $\text{Im}\zeta \geq 0$  and if  $u$  satisfies (C-1) then the following integral equation (which is defined on the space  $\mathcal{M}$  of regular functions such that  $e^{i\zeta x} \phi(x)$  is bounded as  $x \rightarrow -\infty$ ).

$$e^{i\zeta x} \phi(x) = 1 + \int_{-\infty}^x M(x,y) e^{i\zeta y} \phi(y) dy \quad (C-3)$$

admits a unique solution  $\phi \in \mathcal{M}$ . Furthermore this solution satisfies:

- i.  $\phi(x) \sim e^{-i\zeta x}$  as  $x \rightarrow -\infty$  (trivial)
- ii.  $\phi(x)$  is an analytic function of  $\zeta$  if  $\text{Im}\zeta > 0$
- iii.  $\phi e^{i\zeta x}$  is bounded as  $x \rightarrow +\infty$

We will not give here all the details of the proof which uses the classical arguments of Neumann series.

The existence of the solution is proven by considering the sequence:

$$e^{i\zeta x} \phi^{(n)}(x) = 1 + \int_{-\infty}^x M(x,y) e^{i\zeta y} \phi^{(n-1)}(y) dy \quad (C-4)$$

By taking the limit  $n \rightarrow \infty$  of this expression, it is obvious that the limit of this sequence if it exists satisfies the integral equation. The limit of this sequence is also given by the sum of the Neumann series (if it converges)

$$e^{i\zeta x} \phi(x) = 1 + \int_{-\infty}^x M(x,y) dy + \int_{-\infty}^x M(x,y) dy \int_{\infty}^y M(y,u) du + \dots \quad (C-5)$$

Under the assumption  $\text{Im}\zeta \geq 0$  and  $\int_{-\infty}^{+\infty} |u(x)| dx < +\infty$ . This series is absolutely convergent. This proves the existence and the boundedness of the solution. If  $\text{Im}\zeta > 0$  one may differentiate term by term up to any order with respect to  $\zeta$ , the result is still an absolutely convergent series. This proves the analyticity of the solution.

Let us now consider  $\phi = \begin{pmatrix} \phi_1 \\ \phi_2 \end{pmatrix}$  where  $\phi_1$  and  $\phi_2$  are defined by:

$$\begin{cases} \phi_1 \text{ is solution of (C-3)} \\ \phi_2 \text{ is given by } e^{i\zeta x} \phi_2(x) = - \int_{-\infty}^x e^{2i\zeta(x-y)} u^*(y) e^{i\zeta y} \phi_1(y) dy \end{cases} \quad (C-6)$$

If  $\text{Im}\zeta \geq 0$  it is always possible to define  $\phi_2$  in this way. As  $e^{i\zeta y} \phi_1(y)$  is bounded as  $x \rightarrow +\infty$  it is easy to check that  $e^{i\zeta x} \phi(x)$  is also bounded as  $x \rightarrow +\infty$ . We have obviously  $\phi \sim \begin{pmatrix} 1 \\ 0 \end{pmatrix} e^{-i\zeta x}$  as  $x \rightarrow -\infty$  and by simply plugging into (B-8) it is easy to check that  $\phi = \begin{pmatrix} \phi_1 \\ \phi_2 \end{pmatrix}$  satisfies (B-8)

(i.e., (C-3) + (C-6) is equivalent to (B-8) + specified boundary conditions as  $x \rightarrow -\infty$ ). Furthermore as  $\phi_1$  is an analytic function of  $\zeta$  for  $\text{Im}\zeta > 0$ , so is  $\phi_2$ .

At this point we have proven the existence of  $\phi$  for  $\text{Im}\zeta \geq 0$  and its analyticity for  $\text{Im}\zeta > 0$ . We can do exactly the same for  $\psi$ . Now it is obvious by simply looking at the eigen value problem (B-8) that

if

$$f = \begin{pmatrix} f_1(\zeta, x) \\ f_2(\zeta, x) \end{pmatrix} \text{ is an eigen function for } \zeta \text{ then:}$$

$$\bar{f} = \begin{pmatrix} f_1^*(\zeta^*, x) \\ -f_2^*(\zeta^*, x) \end{pmatrix} \text{ is an eigen function for } \zeta^* \quad (C-7)$$

When  $\zeta$  is real  $\zeta = \zeta^*$  and we have proven the existence of the four functions  $\phi, \bar{\phi}, \psi, \bar{\psi}$ . Furthermore, as an immediate corollary of the results on  $\phi$  and  $\psi$ :

$\bar{\phi}$  and  $\bar{\psi}$  are defined for  $\text{Im}\zeta \leq 0$  and are analytic functions of  $\zeta$  for  $\text{Im}\zeta < 0$ . (C-8)

The independence of  $(\psi, \bar{\psi})$  and  $(\phi, \bar{\phi})$  can be proven by considering the Wronskian

$$W(v, w) = v_1 w_2 - v_2 w_1$$

If  $v$  and  $w$  are solutions of (3-8) with the same  $\zeta$ , then it is just a matter of algebra to check that:  $\frac{dW}{dx} = 0$  which implies  $W = C = \text{constant}$  (C-10)

Then obviously

- i. if  $C = 0$   $v$  and  $w$  are linearly dependent
- ii. if  $C \neq 0$   $v$  and  $w$  are linearly independent

By considering the values of the Wronskian of  $(\phi, \bar{\phi})$  and  $(\psi, \bar{\psi})$  as  $x$  we have  $W(\phi, \bar{\phi}) = 1 = W(\psi, \bar{\psi})$  hence  $(\phi, \bar{\phi})$  and  $(\psi, \bar{\psi})$  are two sets of independent solutions.

Let us now define  $a(\zeta)$  for  $\zeta \geq 0$  by:

$$a(\zeta) = \lim_{x \rightarrow +\infty} (e^{i\zeta x} \phi_1(x)) = 1 + \int_{-\infty}^{+\infty} M(x, y) e^{i\zeta y} \phi(y) dy \quad (C-11)$$

The integral is convergent at  $+\infty$  since  $e^{i\zeta x} \phi(x)$  is bounded as  $x \rightarrow +\infty$

Since  $\phi$  is an analytic function if  $\text{Im}\zeta > 0$ , so is  $a$ . It is obvious that

this definition of  $a(\zeta)$  for  $\text{Im}\zeta \geq 0$  coincides with these given when  $\zeta$  is real by equation (B-10). As  $a$  is analytic for  $\text{Im}\zeta > 0$  it has only a finite number of zeros in its analyticity region. (This is a general result on analytic functions.) We call these zeros  $\zeta_k$   $k = 1, \dots, N$

Let us prove that if  $\zeta = \zeta_k$  then  $\phi(\zeta_k, x) = b_k \psi(\zeta_k, x)$ . For this we have only to prove that  $W(\phi, \psi) = 0$ .

Let us consider  $W(\phi, \psi)$  when  $\zeta = \zeta_k$  and as  $x \rightarrow +\infty$

- as  $a(\zeta_k) = 0 \Rightarrow \lim_{x \rightarrow +\infty} \phi_1 e^{i\zeta_k x} = 0$  but  $\psi_2 \sim e^{i\zeta_k x}$  as  $x \rightarrow +\infty$

$\Rightarrow \phi_1 \psi_2 \rightarrow 0$  as  $x \rightarrow +\infty$

- obviously  $e^{i\zeta} \phi_2(x)$  is bounded as  $x \rightarrow +\infty$ . Furthermore the equivalent formula of (C-6) for  $\psi$  shows that  $e^{-i\zeta x} \psi_1(x) \rightarrow 0$  as  $x \rightarrow +\infty$

Hence

$$\phi_2 \psi_1 = \phi_2 e^{i\zeta x} e^{-i\zeta x} \psi_1 \rightarrow 0 \text{ as } x \rightarrow +\infty$$

It follows that

$$W(\phi, \psi) = \phi_1 \psi_2 - \phi_2 \psi_1 \rightarrow 0 \text{ as } x \rightarrow +\infty \Rightarrow W(\phi, \psi) = 0$$

All the results of theorem 1 are then proven.

To be able to solve the inverse scattering problem we need some more technical results:

- first we need the analyticity properties to remain valid on the real axis. It is not difficult to see by considering the Neumann series giving  $\phi$ , that this property will be satisfied if the following conditions on  $u$  are required.

$$\int_{-\infty}^{+\infty} |x|^n u(x) dx < +\infty \text{ for any } n \tag{C-12}$$

• Second we need some asymptotic expression for  $\phi$ ,  $\bar{\psi}$  and  $a$  for large  $\zeta$ . Let us prove the formula for  $\phi_1$ . By partial integration it is easy to see that when

$$M(x,y) = -u^*(y) \int_{-\infty}^x e^{2i\zeta(z-y)} u(z) dz \sim -\frac{u^*(y)}{2i\zeta} \left\{ e^{2i\zeta(x-y)} u(x) - u(y) \right\} + O(1/\zeta^2) \quad (C-13)$$

If we use this expression in the Neumann series for  $\phi_1$  we have

$$\begin{aligned} \phi_1 e^{i\zeta x} &= 1 + \int_{-\infty}^x M(x,y) dy + \int_{-\infty}^x M(x,y) dy \int_{-\infty}^y M(y,u) du + \dots \\ &\sim 1 + \frac{1}{2i\zeta} \int_{-\infty}^x |u(y)|^2 dy - \frac{1}{2i\zeta} u(x) \int_{-\infty}^x u^*(y) e^{2i\zeta(x-y)} dy + O\left(\frac{1}{\zeta^2}\right) \end{aligned}$$

By using once more integration by parts, the last term is shown to be  $O\left(\frac{1}{\zeta^2}\right)$ , so we have:

$$\phi_1 e^{i\zeta x} \sim 1 + \frac{1}{2i\zeta} \int_{-\infty}^x |u(y)|^2 dy + O\left(\frac{1}{\zeta^2}\right) \quad (a)$$

The same kind of manipulations give the following results:

$$\left\{ \begin{aligned} \phi_2 e^{i\zeta x} &\sim \frac{1}{2i\zeta} u^*(x) + O\left(\frac{1}{\zeta^2}\right) & (b) \\ \bar{\psi}_1 e^{i\zeta x} &\sim 1 - \frac{1}{2i\zeta} \int_x^{+\infty} |u(y)|^2 dy + O\left(\frac{1}{\zeta^2}\right) & (c) \\ \bar{\psi}_2 e^{i\zeta x} &\sim \frac{1}{2i\zeta} u^*(x) + O\left(\frac{1}{\zeta^2}\right) & (d) \\ a &\sim 1 + \frac{1}{2i\zeta} \int_{-\infty}^{+\infty} |u(y)|^2 dy + O\left(\frac{1}{\zeta^2}\right) & (e) \end{aligned} \right. \quad (C-14)$$

Proof of theorem 2:

We use the method explained in reference [1] this method proceeds in the inverse way: given one eigen value problem, find the equations which can be solved by this problem.

Let us consider the following eigen value problem for  $v = \begin{pmatrix} v_1 \\ v_2 \end{pmatrix}$

$$\begin{cases} v_{1x} + i\zeta v_1 = q(x,t)v_2 \\ v_{2x} - i\zeta v_2 = r(x,t)v_1 \end{cases} \quad (D-1a)$$

which can be written

$$v_x = Mv \text{ with } M = \begin{pmatrix} -i\zeta & q \\ r & i\zeta \end{pmatrix} \quad (D-1b)$$

$r$  and  $q$  are for the moment two unknown functions such that  $r$  and  $q \rightarrow 0$  as  $t \rightarrow \pm \infty$ . All the results of the previous theorem, in which  $q = -r^*$ , can with some minor changes, be extended to this problem.

We wish to find the evolution equations for  $q$  and  $r$  such that the two following properties are satisfied.

- i. the discrete eigen values of (D-1) are constant in time
- ii. it is possible to follow the scattering datas of (D-1) time

To satisfy ii. we insist that the time evolution of  $v$  is governed by:

$$v_t = Nv \quad N = \begin{pmatrix} A(x,t) & B(x,t) \\ C(x,t) & D(x,t) \end{pmatrix} \quad (D-2)$$

There is a compatibility condition between D-1 and D-2 this condition is:

$$v_{xt} = M_t v + M v_t = (M_t + MN)v = v_{tx} = N_x v + N v_x = (N_x + NM)v$$

which gives

$$N_x - M_t + NM - MN = 0 \quad (D-3)$$

If we insist on i., i.e.,  $\zeta_t = 0$ , equation D-3 can be written

$$A_x = qC - rB \quad (a)$$

$$B_x + 2i\zeta B = q_t - 2Aq \quad (b) \quad (D-4)$$

$$C_x - 2i\zeta C = r_t + 2Ar \quad (c)$$

$D = -A + d(t)$  where  $d(t)$  is an arbitrary function of  $t$ .

In general these inhomogeneous equations will have a solution only if  $q$  and  $r$  satisfy certain relations. These are the governing equations we want to find.

A broad class of solutions of D-4 can be easily found by writing:

$$A = \sum_{n=0}^N a^{(n)}(x,t) \zeta^n \quad B = \sum_{n=0}^N b^{(n)}(x,t) \zeta^n$$

$$C = \sum_{n=0}^N c^{(n)}(x,t) \zeta^n \quad (D-5)$$

If we insert D-5 into D-4 and identify all the power of  $\zeta$  we find:  $a^{(N)}$  is an arbitrary function of time;  $b^{(N)} = c^{(N)} = 0$ ;  $b^{(i)}$ ,  $c^{(i)}$  are found by considering the  $\zeta^{i+1}$  term in D-4 b and c;  $a^{(i)}$ , which is always defined with an additive arbitrary function of time, is found by considering the  $\zeta^i$  term in D-4a; the  $\zeta^0$  terms in D-4 b and c give the sought evolution equations. If  $N = 3$  it is easy to see that the corresponding equations are:

$$\begin{cases} 0 = q_t + \frac{i}{4} a^{(3)} \{ q_{xxx} - 6qrq_x \} + \frac{1}{2} a^{(2)} \{ q_{xx} - 2q^2 r \} - ia^{(1)} q_x - 2a^{(0)} q & (a) \\ 0 = r_t + \frac{i}{4} a^{(3)} \{ r_{xxx} - 6qrr_x \} - \frac{1}{2} a^{(2)} \{ r_{xx} - 2qr^2 \} - ia^{(1)} r_x + 2a^{(0)} r & (b) \end{cases} \quad (D-6)$$

$a^{(0)}$ ,  $a^{(1)}$ ,  $a^{(2)}$ ,  $a^{(3)}$  are arbitrary functions of  $t$ ; the corresponding values of  $A$ ,  $B$  and  $C$  are not useful in this general case.

If we take  $a^{(0)} = a^{(1)} = a^{(3)} = 0$   $a^{(2)} = -2i$  and  $r = -q^*$  equations D-6 a and b are complex conjugate and reduce to:

$$q_t - iq_{xx} - 2i|q|^2 q = 0 \quad \text{which is the cubic Schrödinger equation}$$

The corresponding values of A, B, C are

$$\begin{cases} A = -2i\zeta^2 + i|q|^2 \\ B = 2q - iq_x \\ C = -2q^* - iq_x^* = B^* \end{cases} \quad (D-7)$$

At this point the results are: if  $q$  is solution of the cubic Schrödinger equation  $iq_t + q_{xx} + 2|q|^2 q = 0$  then the eigen value problem D-1 with  $r = -q^*$  has the following properties:

- i. The eigen values are constant
- ii. The time evolution of the eigen functions is given by D-2

Remark: if we had taken  $r = +q^*$  instead of  $-q^*$  the result would have been that the governing equation which can be solved by D-1 (with  $r = q^*$ ) is

$$iq_t + q_{xx} - 2|q|^2 q$$

It is now easy to follow the evolution of the scattering datas in  $t$ . Let us first remark that as  $x \rightarrow -\infty$   $B \rightarrow 0$ ,  $C \rightarrow 0$ ,  $A \rightarrow A_{(-)} = -2i\zeta^2$  so D-2 becomes

$$\begin{cases} v_{1t} \sim A_{(-)} v_1 \\ v_{2t} \sim -A_{(-)} v_2 \end{cases} \quad \text{as } x \rightarrow -\infty \quad (D-8)$$

$\phi$  which behaves as  $\begin{pmatrix} 1 \\ 0 \end{pmatrix} e^{-i\zeta x}$  as  $x \rightarrow -\infty$  does not satisfy D-8; it is because by choosing A, B, C and D we have in fact imposed some kind of boundary conditions on  $v$ . It is obvious that it is  $\phi e^{A_{(-)}t}$  which satisfies D-8 and the D-2. We can write D-2 as

$$\phi_t = \begin{pmatrix} A - A_{(-)} & B \\ C & -A - A_{(-)} \end{pmatrix} \phi \quad (D-9)$$

but  $\phi = a(\zeta, t) \bar{\psi} + b(\zeta, t) \psi \sim \begin{pmatrix} ae^{-i\zeta x} \\ be^{i\zeta x} \end{pmatrix}$  as  $x \rightarrow +\infty$ ; this implies, by taking the limit of D-9 as  $x \rightarrow +\infty$



$$\begin{cases} a_t = (A_{(+)} - A_{(-)}) a + B_{(+)} b \\ b_t = C_{(+)} a - (A_{(+)} + A_{(-)}) b \end{cases} \quad (D-10)$$

where  $A_{(+)} = \lim_{x \rightarrow +\infty} A(\zeta, x, t) = A_{(-)} - 2i\zeta^2$      $B_{(+)} = \lim_{x \rightarrow +\infty} B(\zeta, x, t) e^{2i\zeta x}$

$= 0 = C_{(+)}$

so D-10 gives:

$$\begin{cases} a_t = 0 \Rightarrow a(\zeta, t) = a(\zeta, 0) \\ b_t = -4i\zeta^2 b \Rightarrow b(\zeta, t) = b(\zeta, 0) \exp 4i\zeta^2 t \end{cases}$$

Proof of theorem 3:

To simplify the notations, we do not write explicitly the t dependence:

- Let us first establish equations A-14.

For  $\zeta$  in the upper half plane it is possible to define  $\phi(\zeta', x)$  and  $a(\zeta', x)$ . Let us consider the following integral:

$$I = \oint_{\partial K_R} \frac{d\zeta' \phi(\zeta', x)}{a(\zeta') (\zeta' - \zeta)} e^{i\zeta' x} \quad (E-1)$$

in which  $\text{Im}\zeta < 0$  and  $\partial K_R$  is a contour in the upper half plane, which contains all the zeros of  $a(\zeta)$

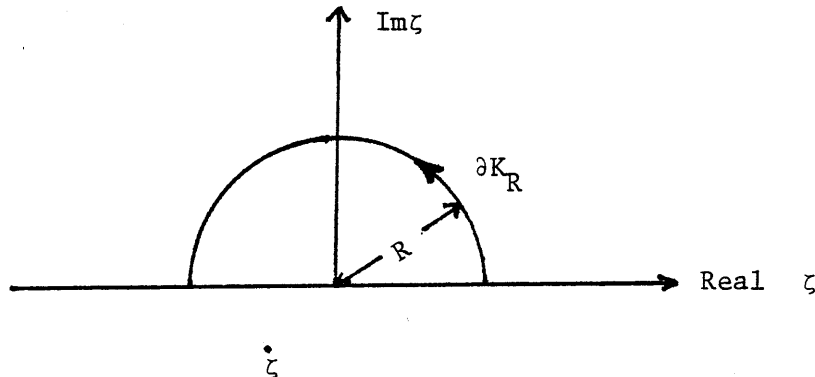

$$\begin{aligned}
& \text{as } R \rightarrow +\infty \quad I + \lim_{R \rightarrow +\infty} \int_{|\zeta'|=R, \text{Im}\zeta' > 0} d\zeta' \frac{\phi(\zeta', x) e^{i\zeta'x}}{a(\zeta')(\zeta' - \zeta)} \\
& + \int_{-\infty}^{+\infty} d\zeta' \frac{\phi(\zeta', x) e^{i\zeta'x}}{a(\zeta')(\zeta' - \zeta)} = 2\pi i \sum \text{residus} \\
& = 2\pi i \sum_{k=1}^N \frac{\phi(\zeta_k, x) e^{i\zeta_k x}}{a'(\zeta_k)(\zeta_k - \zeta)} = 2\pi i \sum_{k=1}^N \frac{b_k \psi(\zeta_k, x) e^{i\zeta_k x}}{a'(\zeta_k)(\zeta_k - \zeta)}
\end{aligned} \tag{E-2}$$

where we have used:

- i. Cauchy theorem
- ii. expression of the residus when  $\zeta_k$  are simple zeros of a
- iii. the definition of  $b_k$

From C-14 we have:

$$\begin{cases} \phi_1 e^{i\zeta x} \sim 1 + \frac{1}{2i\zeta} \int_{-\infty}^{\infty} |u(y)|^2 dy + O\left(\frac{1}{\zeta^2}\right) \\ \phi_2 e^{i\zeta x} \sim + \frac{1}{2i\zeta} u^*(x) + O\left(\frac{1}{\zeta^2}\right) \end{cases} \quad \text{as } |\zeta| \rightarrow \infty$$

and  $a(\zeta) \rightarrow 1$  as  $|\zeta| \rightarrow \infty$

It is easy to see that the integral along the half circle gives

$$i\pi \begin{pmatrix} 1 \\ 0 \end{pmatrix} \text{ as } R \rightarrow \infty$$

Now by using the fact that on the real axis  $\phi = a\psi + b\bar{\psi}$  we have proved:

$$\begin{aligned}
& i\pi \begin{pmatrix} 1 \\ 0 \end{pmatrix} + \int_{-\infty}^{+\infty} d\zeta' \frac{\bar{\psi}(\zeta', x)}{(\zeta' - \zeta)} e^{i\zeta'x} + \int_{-\infty}^{+\infty} d\zeta' \frac{b(\zeta')}{a(\zeta')} \frac{\psi(\zeta', x)}{(\zeta' - \zeta)} e^{i\zeta'x} = \\
& 2\pi i \sum_{k=1}^N \frac{b_k(\zeta_k, x)}{a'(\zeta_k)(\zeta_k - \zeta)} \quad (E-3)
\end{aligned}$$

Now we evaluate the integral on  $\bar{\psi}$  by using the fact that  $\bar{\psi}$  can be defined in the lower half plane: we consider the following contour:

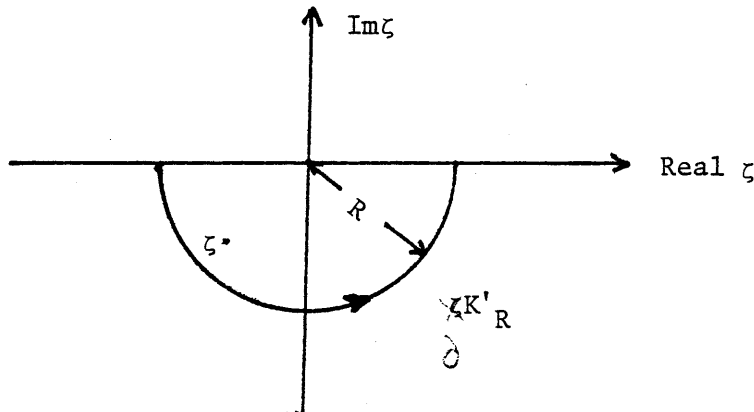

By Cauchy theorem we have:

$$\begin{aligned}
\oint_{\partial K'_R} d\zeta' \frac{\bar{\psi}(\zeta', x)}{(\zeta' - \zeta)} e^{i\zeta'x} &= 2i\pi \bar{\psi}(\zeta, x) e^{i\zeta x} = \int_{-\infty}^{+\infty} d\zeta' \frac{\bar{\psi}(\zeta', x)}{(\zeta' - \zeta)} e^{i\zeta'x} \\
&+ \int_{|\zeta'|=R, \text{Im}\zeta' < 0} d\zeta' \frac{\bar{\psi}(\zeta', x)}{(\zeta' - \zeta)} e^{i\zeta'x} \quad (E-5)
\end{aligned}$$

By using the asymptotic expression C-14 for  $\bar{\psi}(\zeta', x)e^{i\zeta'x}$  it is easy to show that the integral on the half circle gives again  $i\pi \begin{pmatrix} 1 \\ 0 \end{pmatrix}$ .

We have then proved:

$$\text{for } \text{Im}\zeta < 0$$

$$\bar{\psi}(\zeta, x) e^{i\zeta x} = \frac{1}{2\pi i} \int_{-\infty}^{+\infty} d\zeta' \frac{b(\zeta')}{a(\zeta')} \frac{\psi(\zeta', x)}{(\zeta' - \zeta)} e^{i\zeta' x} + \begin{pmatrix} 1 \\ 0 \end{pmatrix} - \sum_{k=1}^N \frac{b_k \psi(\zeta_k, x) e^{i\zeta_k x}}{a'(\zeta_k)(\zeta_k - \zeta)} \tag{E-6}$$

If we take  $\zeta = \zeta^*$  and use the fact that  $\bar{\psi}(\zeta, x) = \begin{pmatrix} \psi_2^*(\zeta^*, x) \\ -\psi_1^*(\zeta^*, x) \end{pmatrix}$  (cf C

equation E-6 is nothing else but B-12a and B-12b\*.

At this point we have 2 N integral equations for the 2N + 2 unknown  $\psi_1(\zeta_k, x), \psi_2(\zeta_k, x)$   $k = 1, \dots, N$  and  $\psi_1(\zeta, x), \psi_2(\zeta, x)$  for  $\zeta$  real.

We need two more integral equations which are obtained by using the same procedure as to establish E-6 but we have to be more careful since for  $\zeta$  real I (cf E-1) is singular for  $\zeta' = \zeta$ .

This problem is solved by considering the principal values of the integrals:

if we consider the following contours:

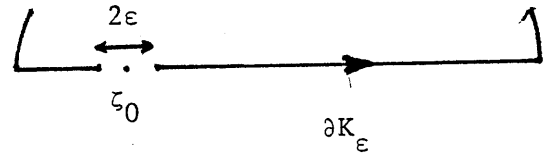
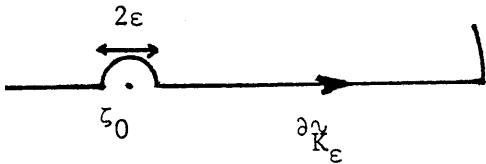

$$\int_{\partial K_\epsilon} \frac{u(\zeta') d\zeta'}{\zeta' - \zeta_0} = \int_{\partial K_\epsilon} \frac{u(\zeta') d\zeta'}{(\zeta' - \zeta_0)} + \int_{|\zeta' - \zeta_0| = \epsilon} \frac{u(\zeta') d\zeta'}{(\zeta' - \zeta_0)} = \int_{\partial K_\epsilon} d\zeta' \{ \} + \int_{\text{Im} \zeta > 0}$$

$$\int_{\pi}^0 \frac{u(\zeta_0 + \epsilon e^{i\theta})}{\epsilon e^{i\theta}} \epsilon e^{i\theta} i d\theta \xrightarrow{\epsilon \rightarrow 0} \oint \frac{u(\zeta)}{(\zeta - \zeta_0)} d\zeta - i\pi u(\zeta_0) \tag{E-7}$$

where  $\oint \frac{u(\zeta)}{(\zeta - \zeta_0)} d\zeta = \text{principal value of the integral} = \lim_{\epsilon \rightarrow 0} \int_{\partial K\epsilon} \frac{u(\zeta)d\zeta}{(\zeta - \zeta_0)}$

The consequence is that in all the previous algebra we have to replace when necessary

$$\int_{\partial K} \frac{u(\zeta)}{(\zeta - \zeta_0)} d\zeta \text{ by } \oint \frac{u(\zeta)}{(\zeta - \zeta_0)} d\zeta - i\pi u(\zeta_0) \quad (\text{E-8})$$

This gives equation B-12 (c) and (d)

• Let us now establish equation B-13

Let us recall C-14 which gives the asymptotic expansion of  $\bar{\psi}(\zeta, x)$  for large  $\zeta$

$$\bar{\psi}(\zeta, x) e^{i\zeta x} \sim \begin{pmatrix} 1 \\ 0 \end{pmatrix} + \frac{1}{2i\zeta} \left( \int_x^{+\infty} \frac{|u(y)|^2 dy}{u^*(x)} \right) + O\left(\frac{1}{\zeta^2}\right) \text{ for } \text{Im}\zeta < 0$$

But by using E-6 for large  $\zeta$  we find

$$\bar{\psi}(\zeta, x) e^{i\zeta x} \sim \begin{pmatrix} 1 \\ 0 \end{pmatrix} + \frac{1}{\zeta} \left\{ \sum_{k=1}^N \frac{b_k \psi(\zeta_k, x) e^{i\zeta_k x}}{a'(\zeta_k)} - \frac{1}{2\pi i} \int_{-\infty}^{+\infty} \frac{d\zeta' b(\zeta')}{a(\zeta')} \psi(\zeta', x) e^{i\zeta' x} \right\} + O\left(\frac{1}{\zeta^2}\right) \quad (\text{E-9})$$

By equating the two first terms in the asymptotic expansion of  $\bar{\psi}(\zeta, x) e^{i\zeta x}$

(an asymptotic expansion is unique) we find as  $\psi = \begin{pmatrix} \psi_1 \\ \psi_2 \end{pmatrix}$

$$u(x) = -2i \sum_{k=1}^N \frac{b_k^*}{a'^*(\zeta_k)} \psi_2^*(\zeta_k, x) e^{-i\zeta_k^* x} - \frac{1}{\pi} \int_{-\infty}^{+\infty} d'\zeta \frac{b^*(\zeta')}{a^*(\zeta')} \psi_2^*(\zeta', x) e^{-i\zeta' x}$$

which is B-13

We also find an equivalent equation for  $\int_x^{+\infty} |u(x)|^2 dy$  which is more practical to study the envelope of the multi-solitons.

#### Appendix D

In this appendix we give the numerical values of  $\zeta^{th}$  = total free surface elevation;  $k$  wave number;  $C_g$  group velocity in the fixed frame;  $C_g/\sigma$ , shoaling coefficient;  $y_2$  and  $y_3$  the coefficients of the equation. All these numbers are given for:

$$U = 0., 0.4, 0.8, 1.2, 1.6; T = 3., 5., 7.; \text{ and:}$$

$$U = 0.95, 1., 1.05; T = 1., 1.5$$

and  $h$  increases linearly from  $h_c$  to  $h_c + 1$ ;  $h_c$  is the critical depth for a given current (if  $U = 0$  we take arbitrarily  $h_c = 0.5$ ).

\*\*\*WAVES OVER AN UNEVEN BOTTOM\*\*\*

DEPTH PROFILE:

0.5400E+00	0.5800E+00	0.6200E+00	0.6600E+00	0.7000E+00	0.7400E+00
0.7800E+00	0.8200E+00	0.8600E+00	0.9000E+00	0.9400E+00	0.9800E+00
0.1020E+01	0.1060E+01	0.1100E+01	0.1140E+01	0.1180E+01	0.1220E+01
0.1230E+01	0.1280E+01	0.1340E+01	0.1380E+01	0.1420E+01	0.1460E+01
0.1500E+01					

PERIOD. T= 0.3000E+01

WAVENUMBER:

0.4458E+01	0.4437E+01	0.4423E+01	0.4413E+01	0.4405E+01	0.4400E+01
0.4396E+01	0.4393E+01	0.4391E+01	0.4390E+01	0.4389E+01	0.4388E+01
0.4388E+01	0.4387E+01	0.4387E+01	0.4387E+01	0.4387E+01	0.4387E+01
0.4387E+01	0.4387E+01	0.4387E+01	0.4387E+01	0.4386E+01	0.4386E+01
0.4386E+01					

GROUP VELOC. IN FIX. FRA.:

0.2533E+00	0.2501E+00	0.2476E+00	0.2455E+00	0.2439E+00	0.2426E+00
0.2417E+00	0.2409E+00	0.2404E+00	0.2400E+00	0.2396E+00	0.2394E+00
0.2392E+00	0.2391E+00	0.2390E+00	0.2389E+00	0.2389E+00	0.2388E+00
0.2388E+00	0.2388E+00	0.2388E+00	0.2387E+00	0.2388E+00	0.2388E+00
0.2388E+00					

CG/SIGMA, COEF. OF EQUATION Y2, Y3:

0.1209E+00	0.1194E+00	0.1182E+00	0.1172E+00	0.1164E+00	0.1158E+00
0.1154E+00	0.1150E+00	0.1146E+00	0.1146E+00	0.1144E+00	0.1143E+00
0.1142E+00	0.1142E+00	0.1141E+00	0.1141E+00	0.1140E+00	0.1140E+00
0.1140E+00	0.1140E+00	0.1140E+00	0.1140E+00	0.1140E+00	0.1140E+00
0.1140E+00					
0.2562E+02	0.2498E+02	0.2427E+02	0.2355E+02	0.2286E+02	0.2224E+02
0.2168E+02	0.2120E+02	0.2081E+02	0.2048E+02	0.2021E+02	0.1999E+02
0.1983E+02	0.1969E+02	0.1959E+02	0.1951E+02	0.1945E+02	0.1940E+02
0.1936E+02	0.1933E+02	0.1931E+02	0.1930E+02	0.1927E+02	0.1926E+02
0.1926E+02					
0.1726E+03	0.1906E+03	0.2004E+03	0.2092E+03	0.2170E+03	0.2211E+03
0.2302E+03	0.2360E+03	0.2412E+03	0.2457E+03	0.2500E+03	0.2538E+03
0.2575E+03	0.2606E+03	0.2636E+03	0.2664E+03	0.2690E+03	0.2715E+03
0.2737E+03	0.2758E+03	0.2777E+03	0.2796E+03	0.2810E+03	0.2826E+03
0.2841E+03					

PERIOD. T= 0.5000E+01

WAVENUMBER:

0.1994E+01	0.1947E+01	0.1907E+01	0.1871E+01	0.1839E+01	0.1812E+01
0.1787E+01	0.1764E+01	0.1744E+01	0.1727E+01	0.1711E+01	0.1697E+01
0.1684E+01	0.1673E+01	0.1663E+01	0.1654E+01	0.1646E+01	0.1638E+01
0.1632E+01	0.1626E+01	0.1621E+01	0.1616E+01	0.1612E+01	0.1608E+01
0.1608E+01					

GROUP VELOC. IN FIX. FRA.:

0.4748E+00	0.4766E+00	0.4773E+00	0.4772E+00	0.4764E+00	0.4748E+00
0.4729E+00	0.4706E+00	0.4680E+00	0.4651E+00	0.4620E+00	0.4589E+00
0.4557E+00	0.4524E+00	0.4492E+00	0.4460E+00	0.4429E+00	0.4398E+00
0.4370E+00	0.4341E+00	0.4314E+00	0.4289E+00	0.4264E+00	0.4242E+00
0.4221E+00					

CG/SIGMA, COEF. OF EQUATION Y2, Y3:

0.3778E+00	0.3793E+00	0.3798E+00	0.3798E+00	0.3791E+00	0.3779E+00
0.3763E+00	0.3745E+00	0.3724E+00	0.3701E+00	0.3677E+00	0.3651E+00

0.3626E+00	0.3600E+00	0.3574E+00	0.3549E+00	0.3524E+00	0.3500E+00
0.3477E+00	0.3455E+00	0.3433E+00	0.3413E+00	0.3394E+00	0.3376E+00
0.3359E+00					
0.2894E+01	0.2933E+01	0.2977E+01	0.3021E+01	0.3067E+01	0.3115E+01
0.3160E+01	0.3203E+01	0.3244E+01	0.3284E+01	0.3319E+01	0.3350E+01
0.3375E+01	0.3397E+01	0.3414E+01	0.3425E+01	0.3431E+01	0.3438E+01
0.3428E+01	0.3420E+01	0.3408E+01	0.3391E+01	0.3372E+01	0.3347E+01
0.3322E+01					
-0.1435E+02	-0.9917E+01	-0.6602E+01	-0.4084E+01	-0.2122E+01	-0.5504E+00
0.6951E+00	0.1723E+01	0.2578E+01	0.3310E+01	0.3933E+01	0.4478E+01
0.4951E+01	0.5378E+01	0.5768E+01	0.6115E+01	0.6400E+01	0.6737E+01
0.7011E+01	0.7274E+01	0.7522E+01	0.7752E+01	0.7976E+01	0.8180E+01
0.8394E+01					

PERIOD, T= 0.7000E+01

WAVENUMBER:

0.1317E+01	0.1279E+01	0.1244E+01	0.1213E+01	0.1185E+01	0.1159E+01
0.1136E+01	0.1114E+01	0.1095E+01	0.1077E+01	0.1060E+01	0.1045E+01
0.1030E+01	0.1017E+01	0.1004E+01	0.9927E+00	0.9816E+00	0.9717E+00
0.9622E+00	0.9532E+00	0.9449E+00	0.9370E+00	0.9295E+00	0.9225E+00
0.9160E+00					

GROUP VELOC. IN FIX. FRA.:

0.5837E+00	0.6001E+00	0.6102E+00	0.6192E+00	0.6271E+00	0.6341E+00
0.6423E+00	0.6457E+00	0.6503E+00	0.6544E+00	0.6578E+00	0.6603E+00
0.6630E+00	0.6618E+00	0.6602E+00	0.6673E+00	0.6679E+00	0.6682E+00
0.6692E+00	0.6680E+00	0.6674E+00	0.6667E+00	0.6657E+00	0.6645E+00
0.6631E+00					

C3/SIGMA, COEF. OF EQUATION Y2, Y3:

0.6559E+00	0.6686E+00	0.6798E+00	0.6899E+00	0.6986E+00	0.7055E+00
0.7113E+00	0.7193E+00	0.7245E+00	0.7291E+00	0.7328E+00	0.7350E+00
0.7386E+00	0.7406E+00	0.7422E+00	0.7434E+00	0.7441E+00	0.7445E+00
0.7435E+00	0.7442E+00	0.7435E+00	0.7427E+00	0.7417E+00	0.7404E+00
0.7338E+00					
0.7374E+00	0.7323E+00	0.7291E+00	0.7271E+00	0.7268E+00	0.7270E+00
0.7283E+00	0.7302E+00	0.7328E+00	0.7359E+00	0.7397E+00	0.7439E+00
0.7433E+00	0.7536E+00	0.7587E+00	0.7641E+00	0.7696E+00	0.7755E+00
0.7816E+00	0.7875E+00	0.7938E+00	0.7999E+00	0.8058E+00	0.8120E+00
0.8132E+00					
-0.2528E+02	-0.1979E+02	-0.1565E+02	-0.1253E+02	-0.1013E+02	-0.8258E+01
-0.6795E+01	-0.5619E+01	-0.4668E+01	-0.3893E+01	-0.3250E+01	-0.2717E+01
-0.2271E+01	-0.1891E+01	-0.1571E+01	-0.1296E+01	-0.1059E+01	-0.8538E+00
-0.6746E+00	-0.5183E+00	-0.3795E+00	-0.2577E+00	-0.1498E+00	-0.5236E-01
0.3532E-01					

\*\*\*WAVES AND STRONG CURRENT OVER AN UNEVEN BOTTOM\*\*\*

UINF= 0.4000E+00

DEPTH PROFILE:

0.7744E+00	0.8144E+00	0.8544E+00	0.8944E+00	0.9344E+00	0.9744E+00
0.1014E+01	0.1054E+01	0.1094E+01	0.1134E+01	0.1174E+01	0.1214E+01
0.1254E+01	0.1294E+01	0.1334E+01	0.1374E+01	0.1414E+01	0.1454E+01
0.1494E+01	0.1534E+01	0.1574E+01	0.1614E+01	0.1654E+01	0.1694E+01
0.1734E+01					

MEAN FREE SURF. DUE TO THE CURRENT:



0.6839E+00	0.7524E+00	0.8156E+00	0.8683E+00	0.9210E+00	0.9684E+00
0.1017E+01	0.1063E+01	0.1109E+01	0.1154E+01	0.1199E+01	0.1242E+01
0.1286E+01	0.1329E+01	0.1371E+01	0.1415E+01	0.1457E+01	0.1498E+01
0.1541E+01	0.1582E+01	0.1624E+01	0.1666E+01	0.1707E+01	0.1748E+01
0.1790E+01					

PERIOD, T= 0.3000E+01

WAVENUMBER:

0.1625E+01	0.1685E+01	0.1737E+01	0.1779E+01	0.1821E+01	0.1869E+01
0.1847E+01	0.1932E+01	0.1987E+01	0.2001E+01	0.2035E+01	0.2066E+01
0.2098E+01	0.2129E+01	0.2158E+01	0.2186E+01	0.2215E+01	0.2243E+01
0.2270E+01	0.2298E+01	0.2321E+01	0.2340E+01	0.2370E+01	0.2393E+01
0.2417E+01					

GROUP VELOC. IN FIX. FRA.:

0.1109E+01	0.1031E+01	0.9677E+00	0.9197E+00	0.8760E+00	0.8402E+00
0.8036E+00	0.7779E+00	0.7516E+00	0.7285E+00	0.7074E+00	0.6887E+00
0.6716E+00	0.6559E+00	0.6419E+00	0.6286E+00	0.6167E+00	0.6057E+00
0.5955E+00	0.5859E+00	0.5769E+00	0.5685E+00	0.5606E+00	0.5532E+00
0.5481E+00					

CG/SIGMA, COEF. OF EQUATION Y2, Y3:

0.9636E+00	0.8603E+00	0.7782E+00	0.7216E+00	0.6721E+00	0.6323E+00
0.5932E+00	0.5688E+00	0.5427E+00	0.5200E+00	0.4997E+00	0.4819E+00
0.4658E+00	0.4511E+00	0.4382E+00	0.4259E+00	0.4150E+00	0.4049E+00
0.3950E+00	0.3870E+00	0.3785E+00	0.3713E+00	0.3642E+00	0.3577E+00
0.3513E+00					

0.2109E+00	0.2874E+00	0.3646E+00	0.4312E+00	0.4977E+00	0.5556E+00
0.6121E+00	0.6617E+00	0.7074E+00	0.7480E+00	0.7852E+00	0.8185E+00
0.8496E+00	0.8798E+00	0.9083E+00	0.9378E+00	0.9668E+00	0.9970E+00
0.1028E+01	0.1061E+01	0.1095E+01	0.1131E+01	0.1169E+01	0.1207E+01
0.1248E+01					

-0.3024E+01	-0.1025E+01	0.5391E+00	0.1735E+01	0.2890E+01	0.3917E+01
0.4993E+01	0.6003E+01	0.7052E+01	0.8093E+01	0.9161E+01	0.1022E+02
0.1131E+02	0.1242E+02	0.1351E+02	0.1466E+02	0.1578E+02	0.1693E+02
0.1807E+02	0.1923E+02	0.2040E+02	0.2157E+02	0.2274E+02	0.2391E+02
0.2510E+02					

PERIOD, T= 0.5000E+01

WAVENUMBER:

0.9219E+00	0.9403E+00	0.9543E+00	0.9643E+00	0.9733E+00	0.9805E+00
0.9875E+00	0.9937E+00	0.9995E+00	0.1005E+01	0.1010E+01	0.1015E+01
0.1020E+01	0.1025E+01	0.1030E+01	0.1035E+01	0.1039E+01	0.1044E+01
0.1049E+01	0.1053E+01	0.1058E+01	0.1053E+01	0.1067E+01	0.1072E+01
0.1077E+01					

GROUP VELOC. IN FIX. FRA.:

0.1276E+01	0.1226E+01	0.1188E+01	0.1156E+01	0.1126E+01	0.1100E+01
0.1074E+01	0.1051E+01	0.1028E+01	0.1007E+01	0.9860E+00	0.9695E+00
0.9475E+00	0.9293E+00	0.9122E+00	0.8950E+00	0.8790E+00	0.8636E+00
0.8490E+00	0.8348E+00	0.8211E+00	0.8081E+00	0.7956E+00	0.7835E+00
0.7723E+00					

CG/SIGMA, COEF. OF EQUATION Y2, Y3:

0.1779E+01	0.1623E+01	0.1506E+01	0.1423E+01	0.1350E+01	0.1292E+01
0.1237E+01	0.1190E+01	0.1147E+01	0.1108E+01	0.1072E+01	0.1039E+01
0.1009E+01	0.9801E+00	0.9538E+00	0.9283E+00	0.9050E+00	0.8830E+00
0.8625E+00	0.8430E+00	0.8244E+00	0.8069E+00	0.7904E+00	0.7750E+00
0.7602E+00					

0.4933E-01	0.6802E-01	0.8762E-01	0.1051E+00	0.1258E+00	0.1417E+00
0.1652E+00	0.1855E+00	0.2066E+00	0.2277E+00	0.2492E+00	0.2705E+00
0.2922E+00	0.3139E+00	0.3351E+00	0.3569E+00	0.3779E+00	0.3994E+00
0.4134E+00	0.4390E+00	0.4572E+00	0.4755E+00	0.4931E+00	0.5098E+00
0.5258E+00					
-0.7442E+01	-0.5345E+01	-0.4001E+01	-0.3162E+01	-0.2499E+01	-0.2017E+01
-0.1602E+01	-0.1269E+01	-0.9821E+00	-0.7381E+00	-0.5219E+00	-0.3323E+00
-0.1547E+00	-0.8287E-03	0.1422E+00	0.2815E+00	0.4083E+00	0.5291E+00
0.6495E+00	0.7530E+00	0.8606E+00	0.9635E+00	0.1066E+01	0.1164E+01
0.1242E+01					

PERIOD, T= 0.7000E+01

WAVENUMBER:

0.6474E+00	0.6570E+00	0.6633E+00	0.6671E+00	0.6700E+00	0.6720E+00
0.6733E+00	0.6742E+00	0.6748E+00	0.6752E+00	0.6753E+00	0.6753E+00
0.6750E+00	0.6748E+00	0.6745E+00	0.6741E+00	0.6738E+00	0.6733E+00
0.6729E+00	0.6725E+00	0.6721E+00	0.6716E+00	0.6713E+00	0.6709E+00
0.6706E+00					

GROUP VELOC. IN FIX. FRA.:

0.1339E+01	0.1205E+01	0.1279E+01	0.1260E+01	0.1242E+01	0.1227E+01
0.1213E+01	0.1200E+01	0.1187E+01	0.1175E+01	0.1164E+01	0.1153E+01
0.1142E+01	0.1131E+01	0.1121E+01	0.1111E+01	0.1101E+01	0.1091E+01
0.1081E+01	0.1072E+01	0.1062E+01	0.1053E+01	0.1044E+01	0.1035E+01
0.1026E+01					

C0/SIGMA, COEF. OF EQUATION Y2, Y3:

0.2579E+01	0.2381E+01	0.2235E+01	0.2135E+01	0.2048E+01	0.1980E+01
0.1917E+01	0.1863E+01	0.1815E+01	0.1771E+01	0.1731E+01	0.1695E+01
0.1661E+01	0.1629E+01	0.1600E+01	0.1571E+01	0.1545E+01	0.1520E+01
0.1496E+01	0.1473E+01	0.1451E+01	0.1430E+01	0.1410E+01	0.1391E+01
0.1372E+01					
0.1794E-01	0.2447E-01	0.3126E-01	0.3740E-01	0.4391E-01	0.5007E-01
0.5655E-01	0.6309E-01	0.6971E-01	0.7631E-01	0.8304E-01	0.8971E-01
0.9645E-01	0.1033E+00	0.1101E+00	0.1170E+00	0.1240E+00	0.1309E+00
0.1377E+00	0.1446E+00	0.1517E+00	0.1586E+00	0.1656E+00	0.1721E+00
0.1734E+00					
-0.1017E+02	-0.7358E+01	-0.5614E+01	-0.4548E+01	-0.3723E+01	-0.3134E+01
-0.2647E+01	-0.2269E+01	-0.1953E+01	-0.1694E+01	-0.1474E+01	-0.1290E+01
-0.1132E+01	-0.9921E+00	-0.8739E+00	-0.7666E+00	-0.6730E+00	-0.5900E+00
-0.5167E+00	-0.4504E+00	-0.3893E+00	-0.3347E+00	-0.2842E+00	-0.2391E+00
-0.1970E+00					

\*\*\*WAVES AND STRONG CURRENT OVER AN UNEVEN BOTTOM\*\*\*

UINF= 0.8000E+00

DEPTH PROFILE:

0.1013E+01	0.1053E+01	0.1093E+01	0.1133E+01	0.1173E+01	0.1213E+01
0.1253E+01	0.1293E+01	0.1333E+01	0.1373E+01	0.1413E+01	0.1453E+01
0.1493E+01	0.1533E+01	0.1573E+01	0.1613E+01	0.1653E+01	0.1693E+01
0.1733E+01	0.1773E+01	0.1813E+01	0.1853E+01	0.1893E+01	0.1933E+01
0.1973E+01					

MEAN FREE SURF. DUE TO THE CURRENT:

0.1032E+01	0.1114E+01	0.1185E+01	0.1246E+01	0.1305E+01	0.1359E+01
0.1413E+01	0.1463E+01	0.1513E+01	0.1561E+01	0.1610E+01	0.1656E+01
0.1702E+01	0.1748E+01	0.1793E+01	0.1838E+01	0.1882E+01	0.1927E+01

0.1970E+01 0.2014E+01 0.2057E+01 0.2100E+01 0.2143E+01 0.2185E+01  
0.2228E+01

PERIOD. T= 0.3000E+01

WAVENUMBER:

0.1316E+01 0.1365E+01 0.1407E+01 0.1442E+01 0.1476E+01 0.1507E+01  
0.1537E+01 0.1565E+01 0.1593E+01 0.1620E+01 0.1646E+01 0.1671E+01  
0.1695E+01 0.1719E+01 0.1742E+01 0.1765E+01 0.1787E+01 0.1808E+01  
0.1829E+01 0.1850E+01 0.1870E+01 0.1892E+01 0.1910E+01 0.1929E+01  
0.1947E+01

GROUP VELOC. IN FIX. FRA.:

0.1331E+01 0.1245E+01 0.1179E+01 0.1127E+01 0.1082E+01 0.1044E+01  
0.1009E+01 0.9796E+00 0.9522E+00 0.9279E+00 0.9054E+00 0.8853E+00  
0.8666E+00 0.8494E+00 0.8333E+00 0.8185E+00 0.8046E+00 0.7915E+00  
0.7794E+00 0.7678E+00 0.7568E+00 0.7466E+00 0.7367E+00 0.7273E+00  
0.7183E+00

CS/SIGMA, COEF. OF EQUATION Y2, Y3:

0.1239E+01 0.1117E+01 0.1030E+01 0.9615E+00 0.9092E+00 0.8613E+00  
0.8247E+00 0.7910E+00 0.7605E+00 0.7333E+00 0.7093E+00 0.6877E+00  
0.6678E+00 0.6495E+00 0.6326E+00 0.6171E+00 0.6027E+00 0.5892E+00  
0.5767E+00 0.5648E+00 0.5537E+00 0.5432E+00 0.5333E+00 0.5248E+00  
0.5148E+00  
0.1211E+00 0.1526E+00 0.1739E+00 0.2029E+00 0.2241E+00 0.2425E+00  
0.2592E+00 0.2740E+00 0.2879E+00 0.3004E+00 0.3124E+00 0.3235E+00  
0.3345E+00 0.3455E+00 0.3566E+00 0.3678E+00 0.3795E+00 0.3916E+00  
0.4041E+00 0.4173E+00 0.4311E+00 0.4453E+00 0.4602E+00 0.4758E+00  
0.4919E+00  
-0.2043E-01 0.5915E+00 0.1102E+01 0.1544E+01 0.1982E+01 0.2396E+01  
0.2816E+01 0.3227E+01 0.3654E+01 0.4075E+01 0.4512E+01 0.4944E+01  
0.5395E+01 0.5834E+01 0.6291E+01 0.6752E+01 0.7219E+01 0.7692E+01  
0.8155E+01 0.8651E+01 0.9140E+01 0.9627E+01 0.1013E+02 0.1063E+02  
0.1114E+02

PERIOD. T= 0.5000E+01

WAVENUMBER:

0.7355E+00 0.7514E+00 0.7639E+00 0.7738E+00 0.7829E+00 0.7909E+00  
0.7985E+00 0.8055E+00 0.8123E+00 0.8187E+00 0.8250E+00 0.8310E+00  
0.8369E+00 0.8427E+00 0.8484E+00 0.8540E+00 0.8595E+00 0.8651E+00  
0.8704E+00 0.8757E+00 0.8811E+00 0.8863E+00 0.8916E+00 0.8968E+00  
0.9020E+00

GROUP VELOC. IN FIX. FRA.:

0.1588E+01 0.1506E+01 0.1455E+01 0.1414E+01 0.1376E+01 0.1343E+01  
0.1311E+01 0.1272E+01 0.1234E+01 0.1228E+01 0.1202E+01 0.1179E+01  
0.1151E+01 0.1135E+01 0.1114E+01 0.1094E+01 0.1076E+01 0.1057E+01  
0.1040E+01 0.1024E+01 0.1008E+01 0.9927E+00 0.9782E+00 0.9642E+00  
0.9508E+00

CS/SIGMA, COEF. OF EQUATION Y2, Y3:

0.2285E+01 0.2099E+01 0.1964E+01 0.1861E+01 0.1772E+01 0.1697E+01  
0.1629E+01 0.1571E+01 0.1516E+01 0.1466E+01 0.1420E+01 0.1379E+01  
0.1340E+01 0.1303E+01 0.1269E+01 0.1237E+01 0.1207E+01 0.1178E+01  
0.1152E+01 0.1127E+01 0.1103E+01 0.1080E+01 0.1059E+01 0.1039E+01  
0.1019E+01  
0.3223E-01 0.4237E-01 0.5222E-01 0.6151E-01 0.7115E-01 0.8053E-01  
0.9020E-01 0.9970E-01 0.1095E+00 0.1192E+00 0.1291E+00 0.1387E+00  
0.1484E+00 0.1561E+00 0.1676E+00 0.1770E+00 0.1862E+00 0.1953E+00

0.2040E+00	0.2126E+00	0.2209E+00	0.2289E+00	0.2366E+00	0.2441E+00
0.2513E+00					
-0.1741E+01	-0.1301E+01	-0.1011E+01	-0.8064E+00	-0.6491E+00	-0.5072E+00
-0.3910E+00	-0.2935E+00	-0.2034E+00	-0.1236E+00	-0.4920E-01	0.1893E-01
0.8204E-01	0.1434E+00	0.2011E+00	0.2568E+00	0.3104E+00	0.3645E+00
0.4141E+00	0.4642E+00	0.5139E+00	0.5624E+00	0.6108E+00	0.6592E+00
0.7072E+00					

PERIOD, T= 0.7000E+01

WAVENUMBER:

0.5137E+00	0.5219E+00	0.5279E+00	0.5323E+00	0.5360E+00	0.5391E+00
0.5418E+00	0.5441E+00	0.5462E+00	0.5481E+00	0.5498E+00	0.5511E+00
0.5529E+00	0.5542E+00	0.5555E+00	0.5568E+00	0.5579E+00	0.5591E+00
0.5601E+00	0.5612E+00	0.5623E+00	0.5632E+00	0.5642E+00	0.5652E+00
0.5662E+00					

GROUP VELOC. IN FIX. FRA.:

0.1067E+01	0.1622E+01	0.1588E+01	0.1560E+01	0.1534E+01	0.1512E+01
0.1400E+01	0.1471E+01	0.1452E+01	0.1435E+01	0.1417E+01	0.1401E+01
0.1385E+01	0.1370E+01	0.1355E+01	0.1340E+01	0.1326E+01	0.1312E+01
0.1298E+01	0.1285E+01	0.1272E+01	0.1259E+01	0.1246E+01	0.1234E+01
0.1222E+01					

CG/SIGMA, COEF. OF EQUATION Y2, Y3:

0.3339E+01	0.3103E+01	0.2933E+01	0.2806E+01	0.2696E+01	0.2605E+01
0.2523E+01	0.2452E+01	0.2385E+01	0.2326E+01	0.2270E+01	0.2220E+01
0.2172E+01	0.2127E+01	0.2085E+01	0.2045E+01	0.2007E+01	0.1971E+01
0.1937E+01	0.1905E+01	0.1873E+01	0.1843E+01	0.1814E+01	0.1787E+01
0.1730E+01					
0.1193E-01	0.1560E-01	0.1914E-01	0.2245E-01	0.2588E-01	0.2921E-01
0.3235E-01	0.3603E-01	0.3955E-01	0.4305E-01	0.4665E-01	0.5021E-01
0.5380E-01	0.5756E-01	0.6129E-01	0.6504E-01	0.6883E-01	0.7267E-01
0.7617E-01	0.8037E-01	0.8429E-01	0.8816E-01	0.9209E-01	0.9602E-01
0.9996E-01					
-0.2442E+01	-0.1883E+01	-0.1527E+01	-0.1284E+01	-0.1094E+01	-0.9477E+00
-0.8253E+00	-0.7265E+00	-0.6399E+00	-0.5672E+00	-0.5030E+00	-0.4479E+00
-0.3931E+00	-0.3538E+00	-0.3141E+00	-0.2782E+00	-0.2456E+00	-0.2157E+00
-0.1887E+00	-0.1632E+00	-0.1397E+00	-0.1182E+00	-0.9778E-01	-0.7874E-01
-0.6082E-01					

\*\*\* WAVES AND STRONG CURRENT OVER AN UNEVEN BOTTOM \*\*\*

UINF= 0.1200E+01

DEPTH PROFILE:

0.1014E+01	0.1054E+01	0.1094E+01	0.1134E+01	0.1174E+01	0.1214E+01
0.1254E+01	0.1294E+01	0.1334E+01	0.1374E+01	0.1414E+01	0.1454E+01
0.1494E+01	0.1534E+01	0.1574E+01	0.1614E+01	0.1654E+01	0.1694E+01
0.1734E+01	0.1774E+01	0.1814E+01	0.1854E+01	0.1894E+01	0.1934E+01
0.1974E+01					

MEAN FREE SURF. DUE TO THE CURRENT:

0.9736E+00	0.9164E+00	0.8767E+00	0.8437E+00	0.8173E+00	0.7953E+00
0.7755E+00	0.7568E+00	0.7403E+00	0.7249E+00	0.7117E+00	0.6985E+00
0.6853E+00	0.6753E+00	0.6643E+00	0.6544E+00	0.6456E+00	0.6368E+00
0.6203E+00	0.6203E+00	0.6121E+00	0.6049E+00	0.5972E+00	0.5906E+00
0.5840E+00					

PERIOD. T= 0.3000E+01

WAVENUMBER:

0.9977E+00	0.9669E+00	0.9447E+00	0.9258E+00	0.9101E+00	0.8958E+00
0.8815E+00	0.8727E+00	0.8620E+00	0.8519E+00	0.8431E+00	0.8310E+00
0.8257E+00	0.8180E+00	0.8101E+00	0.8030E+00	0.7965E+00	0.7900E+00
0.7834E+00	0.7775E+00	0.7712E+00	0.7656E+00	0.7596E+00	0.7544E+00
0.7491E+00					

GROUP VELOC. IN FIX. FRA.:

0.1912E+01	0.2003E+01	0.2071E+01	0.2130E+01	0.2180E+01	0.2223E+01
0.2263E+01	0.2302E+01	0.2339E+01	0.2372E+01	0.2402E+01	0.2434E+01
0.2463E+01	0.2491E+01	0.2519E+01	0.2545E+01	0.2569E+01	0.2593E+01
0.2616E+01	0.2641E+01	0.2665E+01	0.2687E+01	0.2710E+01	0.2731E+01
0.2753E+01					

CG/SIGMA, COEF. OF EQUATION Y2, Y3:

0.2212E+01	0.2419E+01	0.2585E+01	0.2739E+01	0.2875E+01	0.2998E+01
0.3118E+01	0.3239E+01	0.3354E+01	0.3467E+01	0.3571E+01	0.3680E+01
0.3785E+01	0.3897E+01	0.3992E+01	0.4092E+01	0.4184E+01	0.4281E+01
0.4382E+01	0.4474E+01	0.4576E+01	0.4668E+01	0.4771E+01	0.4863E+01
0.4958E+01					
0.2846E-01	0.2193E-01	0.1799E-01	0.1506E-01	0.1296E-01	0.1135E-01
0.1003E-01	0.8872E-02	0.7933E-02	0.7120E-02	0.6467E-02	0.5862E-02
0.5338E-02	0.4894E-02	0.4477E-02	0.4124E-02	0.3828E-02	0.3546E-02
0.3291E-02	0.3059E-02	0.2835E-02	0.2651E-02	0.2461E-02	0.2307E-02
0.2161E-02					
-0.1088E+01	-0.1451E+01	-0.1752E+01	-0.2038E+01	-0.2301E+01	-0.2546E+01
-0.2791E+01	-0.3042E+01	-0.3291E+01	-0.3544E+01	-0.3773E+01	-0.4032E+01
-0.4274E+01	-0.4521E+01	-0.4784E+01	-0.5035E+01	-0.5278E+01	-0.5528E+01
-0.5803E+01	-0.6039E+01	-0.6299E+01	-0.6587E+01	-0.6872E+01	-0.7133E+01
-0.7409E+01					

PERIOD. T= 0.5000E+01

WAVENUMBER:

0.5786E+00	0.5642E+00	0.5534E+00	0.5439E+00	0.5359E+00	0.5289E+00
0.5225E+00	0.5162E+00	0.5105E+00	0.5050E+00	0.5001E+00	0.4952E+00
0.4905E+00	0.4863E+00	0.4819E+00	0.4778E+00	0.4742E+00	0.4705E+00
0.4668E+00	0.4635E+00	0.4598E+00	0.4566E+00	0.4532E+00	0.4502E+00
0.4471E+00					

GROUP VELOC. IN FIX. FRA.:

0.2085E+01	0.2155E+01	0.2207E+01	0.2254E+01	0.2294E+01	0.2329E+01
0.2362E+01	0.2394E+01	0.2424E+01	0.2454E+01	0.2480E+01	0.2507E+01
0.2533E+01	0.2557E+01	0.2582E+01	0.2605E+01	0.2626E+01	0.2648E+01
0.2671E+01	0.2691E+01	0.2713E+01	0.2733E+01	0.2755E+01	0.2774E+01
0.2794E+01					

CG/SIGMA, COEF. OF EQUATION Y2, Y3:

0.3837E+01	0.4161E+01	0.4421E+01	0.4665E+01	0.4992E+01	0.5078E+01
0.5270E+01	0.5464E+01	0.5649E+01	0.5832E+01	0.5999E+01	0.6176E+01
0.6347E+01	0.6512E+01	0.6685E+01	0.6837E+01	0.6998E+01	0.7157E+01
0.7322E+01	0.7473E+01	0.7640E+01	0.7792E+01	0.7962E+01	0.8112E+01
0.8258E+01					
0.7286E-02	0.5513E-02	0.4470E-02	0.3708E-02	0.3169E-02	0.2701E-02
0.2426E-02	0.2137E-02	0.1900E-02	0.1699E-02	0.1538E-02	0.1388E-02
0.1262E-02	0.1151E-02	0.1049E-02	0.9680E-03	0.8966E-03	0.8284E-03
0.7636E-03	0.7089E-03	0.6572E-03	0.6133E-03	0.5860E-03	0.5334E-03
0.4936E-03					
-0.2124E+01	-0.2602E+01	-0.3023E+01	-0.3437E+01	-0.3834E+01	-0.4211E+01

-0.4588E+01 -0.4984E+01 -0.5357E+01 -0.5755E+01 -0.6127E+01 -0.6524E+01  
 -0.6942E+01 -0.7269E+01 -0.7697E+01 -0.8188E+01 -0.8576E+01 -0.8979E+01  
 -0.9340E+01 -0.9737E+01 -0.1025E+02 -0.1067E+02 -0.1104E+02 -0.1164E+02  
 -0.1208E+02

PERIOD.T= 0.7000E+01

WAVENUMBER:

0.4090E+00 0.3996E+00 0.3924E+00 0.3861E+00 0.3806E+00 0.3759E+00  
 0.3715E+00 0.3672E+00 0.3632E+00 0.3594E+00 0.3561E+00 0.3526E+00  
 0.3494E+00 0.3464E+00 0.3433E+00 0.3405E+00 0.3380E+00 0.3354E+00  
 0.3327E+00 0.3304E+00 0.3279E+00 0.3256E+00 0.3232E+00 0.3211E+00  
 0.3189E+00

GROUP VELOC. IN FIX. FRA.:

0.2147E+01 0.2207E+01 0.2253E+01 0.2295E+01 0.2331E+01 0.2363E+01  
 0.2393E+01 0.2423E+01 0.2451E+01 0.2479E+01 0.2504E+01 0.2529E+01  
 0.2554E+01 0.2577E+01 0.2601E+01 0.2623E+01 0.2644E+01 0.2665E+01  
 0.2686E+01 0.2706E+01 0.2728E+01 0.2747E+01 0.2768E+01 0.2787E+01  
 0.2806E+01

CG/SIGMA, COEF. OF EQUATION Y2, Y3:

0.5457E+01 0.5896E+01 0.6250E+01 0.6584E+01 0.6880E+01 0.7151E+01  
 0.7415E+01 0.7683E+01 0.7938E+01 0.8192E+01 0.8423E+01 0.8669E+01  
 0.8906E+01 0.9134E+01 0.9375E+01 0.9501E+01 0.9611E+01 0.1003E+02  
 0.1026E+02 0.1047E+02 0.1070E+02 0.1092E+02 0.1115E+02 0.1136E+02  
 0.1158E+02  
 0.2749E-02 0.2080E-02 0.1685E-02 0.1392E-02 0.1192E-02 0.1035E-02  
 0.9100E-03 0.7998E-03 0.7111E-03 0.6332E-03 0.5745E-03 0.5157E-03  
 0.4718E-03 0.4298E-03 0.3891E-03 0.3593E-03 0.3349E-03 0.3062E-03  
 0.2837E-03 0.2619E-03 0.2443E-03 0.2285E-03 0.2133E-03 0.1948E-03  
 0.1867E-03

-0.2900E+01 -0.3567E+01 -0.4145E+01 -0.4685E+01 -0.5275E+01 -0.5746E+01  
 -0.6299E+01 -0.6832E+01 -0.7362E+01 -0.7864E+01 -0.8426E+01 -0.8886E+01  
 -0.9599E+01 -0.1009E+02 -0.1052E+02 -0.1121E+02 -0.1192E+02 -0.1274E+02  
 -0.1297E+02 -0.1331E+02 -0.1420E+02 -0.1488E+02 -0.1579E+02 -0.1561E+02  
 -0.1709E+02

\*\*\* WAVES AND STRONG CURRENT OVER AN UNEVEN BOTTOM \*\*\*

UINF= 0.1600E+01

DEPTH PROFILE:

0.8120E+00 0.8520E+00 0.8920E+00 0.9320E+00 0.9720E+00 0.1012E+01  
 0.1052E+01 0.1092E+01 0.1132E+01 0.1172E+01 0.1212E+01 0.1252E+01  
 0.1292E+01 0.1332E+01 0.1372E+01 0.1412E+01 0.1452E+01 0.1492E+01  
 0.1532E+01 0.1572E+01 0.1612E+01 0.1652E+01 0.1692E+01 0.1732E+01  
 0.1772E+01

MEAN FREE SURF. DUE TO THE CURRENT:

0.1195E+01 0.1130E+01 0.1084E+01 0.1050E+01 0.1013E+01 0.9927E+00  
 0.9638E+00 0.9486E+00 0.9293E+00 0.9119E+00 0.8954E+00 0.8807E+00  
 0.8650E+00 0.8531E+00 0.8403E+00 0.8288E+00 0.8174E+00 0.8073E+00  
 0.7972E+00 0.7871E+00 0.7779E+00 0.7696E+00 0.7609E+00 0.7526E+00  
 0.7448E+00

PERIOD.T= 0.3000E+01

WAVENUMBER:

0.9221E+00 0.8947E+00 0.8746E+00 0.8590E+00 0.8443E+00 0.8329E+00

0.8216E+00	0.8120E+00	0.8026E+00	0.7940E+00	0.7857E+00	0.7782E+00
0.7707E+00	0.7640E+00	0.7572E+00	0.7511E+00	0.7449E+00	0.7394E+00
0.7338E+00	0.7282E+00	0.7231E+00	0.7184E+00	0.7134E+00	0.7086E+00
0.7040E+00					

GROUP VELOC. IN FIX. FRA.:

0.2035E+01	0.2130E+01	0.2203E+01	0.2260E+01	0.2314E+01	0.2360E+01
0.2404E+01	0.2442E+01	0.2479E+01	0.2514E+01	0.2548E+01	0.2579E+01
0.2611E+01	0.2639E+01	0.2668E+01	0.2695E+01	0.2722E+01	0.2746E+01
0.2771E+01	0.2796E+01	0.2820E+01	0.2841E+01	0.2864E+01	0.2886E+01
0.2908E+01					

C3/SIGMA, COEF. OF EQUATION Y2, Y3:

0.2368E+01	0.2573E+01	0.2740E+01	0.2880E+01	0.3017E+01	0.3138E+01
0.3260E+01	0.3369E+01	0.3479E+01	0.3585E+01	0.3691E+01	0.3790E+01
0.3894E+01	0.3990E+01	0.4089E+01	0.4182E+01	0.4278E+01	0.4367E+01
0.4459E+01	0.4554E+01	0.4644E+01	0.4727E+01	0.4819E+01	0.4909E+01
0.4996E+01					
0.2545E-01	0.2029E-01	0.1609E-01	0.1471E-01	0.1282E-01	0.1139E-01
0.1015E-01	0.9174E-02	0.8301E-02	0.7558E-02	0.6890E-02	0.6313E-02
0.5818E-02	0.5384E-02	0.4974E-02	0.4627E-02	0.4297E-02	0.4020E-02
0.3755E-02	0.3503E-02	0.3286E-02	0.3099E-02	0.2907E-02	0.2735E-02
0.2591E-02					
-0.4234E+00	-0.6095E+00	-0.7603E+00	-0.8823E+00	-0.1015E+01	-0.1129E+01
-0.1246E+01	-0.1352E+01	-0.1463E+01	-0.1569E+01	-0.1679E+01	-0.1784E+01
-0.1893E+01	-0.1995E+01	-0.2106E+01	-0.2212E+01	-0.2323E+01	-0.2425E+01
-0.2532E+01	-0.2644E+01	-0.2756E+01	-0.2861E+01	-0.2970E+01	-0.3084E+01
-0.3199E+01					

PERIOD, T= 0.5000E+01

WAVE NUMBER:

0.5398E+00	0.5185E+00	0.5091E+00	0.5016E+00	0.4946E+00	0.4886E+00
0.4829E+00	0.4779E+00	0.4731E+00	0.4685E+00	0.4641E+00	0.4602E+00
0.4531E+00	0.4525E+00	0.4489E+00	0.4455E+00	0.4420E+00	0.4390E+00
0.4359E+00	0.4328E+00	0.4299E+00	0.4273E+00	0.4245E+00	0.4218E+00
0.4192E+00					

GROUP VELOC. IN FIX. FRA.:

0.2252E+01	0.2324E+01	0.2380E+01	0.2425E+01	0.2468E+01	0.2504E+01
0.2539E+01	0.2570E+01	0.2601E+01	0.2630E+01	0.2658E+01	0.2684E+01
0.2711E+01	0.2735E+01	0.2760E+01	0.2783E+01	0.2807E+01	0.2829E+01
0.2819E+01	0.2872E+01	0.2892E+01	0.2911E+01	0.2932E+01	0.2952E+01
0.2971E+01					

C3/SIGMA, COEF. OF EQUATION Y2, Y3:

0.4127E+01	0.4447E+01	0.4708E+01	0.4929E+01	0.5146E+01	0.5336E+01
0.5531E+01	0.5706E+01	0.5883E+01	0.6052E+01	0.6223E+01	0.6382E+01
0.6550E+01	0.6704E+01	0.6865E+01	0.7015E+01	0.7172E+01	0.7315E+01
0.7455E+01	0.7621E+01	0.7767E+01	0.7904E+01	0.8053E+01	0.8200E+01
0.8344E+01					
0.6890E-02	0.5364E-02	0.4420E-02	0.3779E-02	0.3264E-02	0.2878E-02
0.2546E-02	0.2287E-02	0.2056E-02	0.1864E-02	0.1693E-02	0.1540E-02
0.1416E-02	0.1304E-02	0.1200E-02	0.1115E-02	0.1033E-02	0.9645E-03
0.8976E-03	0.8349E-03	0.7812E-03	0.7340E-03	0.6896E-03	0.6455E-03
0.6058E-03					
-0.1040E+01	-0.1259E+01	-0.1450E+01	-0.1618E+01	-0.1793E+01	-0.1958E+01
-0.2126E+01	-0.2281E+01	-0.2440E+01	-0.2607E+01	-0.2772E+01	-0.2931E+01
-0.3102E+01	-0.3254E+01	-0.3424E+01	-0.3599E+01	-0.3785E+01	-0.3954E+01
-0.4115E+01	-0.4293E+01	-0.4470E+01	-0.4622E+01	-0.4839E+01	-0.4990E+01

-0.5156E+01

PERIOD, T= 0.7000E+01

WAVENUMBER:

0.3743E+00	0.3664E+00	0.3603E+00	0.3553E+00	0.3507E+00	0.3467E+00
0.3428E+00	0.3394E+00	0.3351E+00	0.3320E+00	0.3300E+00	0.3273E+00
0.3245E+00	0.3220E+00	0.3194E+00	0.3171E+00	0.3147E+00	0.3123E+00
0.3105E+00	0.3083E+00	0.3063E+00	0.3044E+00	0.3025E+00	0.3006E+00
0.2938E+00					

GROUP VELOC. IN FIX. FRA.:

0.2334E+01	0.2395E+01	0.2443E+01	0.2493E+01	0.2520E+01	0.2553E+01
0.2545E+01	0.2613E+01	0.2641E+01	0.2667E+01	0.2694E+01	0.2718E+01
0.2743E+01	0.2766E+01	0.2789E+01	0.2810E+01	0.2833E+01	0.2853E+01
0.2874E+01	0.2895E+01	0.2915E+01	0.2933E+01	0.2952E+01	0.2972E+01
0.2990E+01					

C3/SIGMA, COEF. OF EQUATION Y2, Y3:

0.5239E+01	0.5320E+01	0.5675E+01	0.6975E+01	0.7270E+01	0.7574E+01
0.7706E+01	0.8038E+01	0.8232E+01	0.8515E+01	0.8750E+01	0.8970E+01
0.9202E+01	0.9415E+01	0.9637E+01	0.9847E+01	0.1006E+02	0.1026E+02
0.1047E+02	0.1069E+02	0.1089E+02	0.1108E+02	0.1129E+02	0.1149E+02
0.1169E+02					
0.2620E-02	0.2040E-02	0.1677E-02	0.1435E-02	0.1237E-02	0.1090E-02
0.9620E-03	0.8621E-03	0.7736E-03	0.7009E-03	0.6372E-03	0.5846E-03
0.5313E-03	0.4904E-03	0.4522E-03	0.4152E-03	0.3862E-03	0.3594E-03
0.3351E-03	0.3105E-03	0.2918E-03	0.2749E-03	0.2557E-03	0.2408E-03
0.2251E-03					

-0.1431E+01	-0.1723E+01	-0.1978E+01	-0.2219E+01	-0.2456E+01	-0.2684E+01
-0.2907E+01	-0.3114E+01	-0.3328E+01	-0.3557E+01	-0.3803E+01	-0.4047E+01
-0.4244E+01	-0.4483E+01	-0.4748E+01	-0.4906E+01	-0.5181E+01	-0.5385E+01
-0.5674E+01	-0.5845E+01	-0.6151E+01	-0.6407E+01	-0.6576E+01	-0.6864E+01
-0.7037E+01					



\*\*\*WAVES AND STRONG CURRENT OVER AN UNEVEN BOTTOM\*\*\*

UNIT= 0.0000100

DEPTH PROFILE:

0.1038E+01	0.1078E+01	0.1118E+01	0.1158E+01	0.1198E+01	0.1238E+01
0.1278E+01	0.1318E+01	0.1358E+01	0.1398E+01	0.1438E+01	0.1478E+01
0.1518E+01	0.1558E+01	0.1598E+01	0.1638E+01	0.1678E+01	0.1718E+01
0.1758E+01	0.1798E+01	0.1838E+01	0.1878E+01	0.1918E+01	0.1958E+01
0.1998E+01					

MEAN FREE SURF. DUE TO THE CURRENT:

0.1147E+01	0.1233E+01	0.1305E+01	0.1369E+01	0.1428E+01	0.1485E+01
0.1539E+01	0.1591E+01	0.1642E+01	0.1692E+01	0.1741E+01	0.1788E+01
0.1836E+01	0.1882E+01	0.1928E+01	0.1974E+01	0.2019E+01	0.2064E+01
0.2108E+01	0.2152E+01	0.2196E+01	0.2240E+01	0.2283E+01	0.2326E+01
0.2369E+01					

PERIOD. T= 0.1000E+01

WAVENUMBER:

0.2070E+01	0.2173E+01	0.2257E+01	0.2331E+01	0.2397E+01	0.2461E+01
0.2519E+01	0.2575E+01	0.2629E+01	0.2680E+01	0.2729E+01	0.2777E+01
0.2824E+01	0.2869E+01	0.2913E+01	0.2955E+01	0.2997E+01	0.3038E+01
0.3078E+01	0.3117E+01	0.3156E+01	0.3194E+01	0.3231E+01	0.3267E+01
0.3303E+01					

GROUP VELOC. IN FIX. FRA.:

0.1201E+01	0.1125E+01	0.1071E+01	0.1028E+01	0.9925E+00	0.9613E+00
0.9342E+00	0.9099E+00	0.8878E+00	0.8674E+00	0.8488E+00	0.8316E+00
0.8152E+00	0.8001E+00	0.7858E+00	0.7722E+00	0.7594E+00	0.7472E+00
0.7356E+00	0.7246E+00	0.7141E+00	0.7039E+00	0.6943E+00	0.6850E+00
0.6761E+00					

CG/SIGMA, COEF. OF EQUATION Y2, Y3:

0.8420E+00	0.7670E+00	0.7148E+00	0.6746E+00	0.6417E+00	0.6133E+00
0.5849E+00	0.5671E+00	0.5477E+00	0.5299E+00	0.5138E+00	0.4990E+00
0.4851E+00	0.4724E+00	0.4604E+00	0.4492E+00	0.4387E+00	0.4287E+00
0.4193E+00	0.4104E+00	0.4020E+00	0.3939E+00	0.3863E+00	0.3790E+00
0.3721E+00					
0.1657E+00	0.1850E+00	0.2010E+00	0.2160E+00	0.2314E+00	0.2478E+00
0.2651E+00	0.2835E+00	0.3032E+00	0.3241E+00	0.3458E+00	0.3685E+00
0.3925E+00	0.4169E+00	0.4424E+00	0.4687E+00	0.4955E+00	0.5233E+00
0.5517E+00	0.5807E+00	0.6103E+00	0.6407E+00	0.6716E+00	0.7029E+00
0.7350E+00					
0.5494E+01	0.7335E+01	0.9032E+01	0.1068E+02	0.1231E+02	0.1398E+02
0.1563E+02	0.1733E+02	0.1904E+02	0.2079E+02	0.2256E+02	0.2435E+02
0.2622E+02	0.2807E+02	0.2998E+02	0.3193E+02	0.3390E+02	0.3591E+02
0.3796E+02	0.4003E+02	0.4212E+02	0.4429E+02	0.4646E+02	0.4864E+02
0.5090E+02					

PERIOD. T= 0.1500E+01

WAVENUMBER:

0.1252E+01	0.1298E+01	0.1336E+01	0.1370E+01	0.1401E+01	0.1431E+01
0.1458E+01	0.1485E+01	0.1511E+01	0.1536E+01	0.1559E+01	0.1583E+01
0.1606E+01	0.1627E+01	0.1649E+01	0.1670E+01	0.1691E+01	0.1711E+01
0.1731E+01	0.1750E+01	0.1769E+01	0.1787E+01	0.1805E+01	0.1823E+01
0.1840E+01					

GROUP VELOC. IN FIX. FRA.:

0.1388E+01	0.1302E+01	0.1237E+01	0.1183E+01	0.1141E+01	0.1102E+01
0.1068E+01	0.1038E+01	0.1011E+01	0.9858E+00	0.9634E+00	0.9423E+00
0.9237E+00	0.9064E+00	0.8900E+00	0.8747E+00	0.8604E+00	0.8470E+00
0.8342E+00	0.8222E+00	0.8109E+00	0.8000E+00	0.7897E+00	0.7800E+00
0.7706E+00					

CG/SIGMA, COEF. OF EQUATION Y2, Y3:

0.1313E+01	0.1190E+01	0.1103E+01	0.1036E+01	0.9814E+00	0.9343E+00
0.8913E+00	0.8591E+00	0.8280E+00	0.7909E+00	0.7749E+00	0.7521E+00
0.7310E+00	0.7120E+00	0.6942E+00	0.6777E+00	0.6625E+00	0.6481E+00
0.6316E+00	0.6219E+00	0.6100E+00	0.5986E+00	0.5879E+00	0.5778E+00
0.5681E+00					
0.1050E+00	0.1293E+00	0.1495E+00	0.1667E+00	0.1819E+00	0.1955E+00
0.2076E+00	0.2185E+00	0.2295E+00	0.2379E+00	0.2468E+00	0.2553E+00
0.2639E+00	0.2722E+00	0.2809E+00	0.2897E+00	0.2988E+00	0.3083E+00
0.3183E+00	0.3286E+00	0.3394E+00	0.3506E+00	0.3623E+00	0.3743E+00
0.3869E+00					
0.2193E+00	0.6931E+00	0.1070E+01	0.1423E+01	0.1762E+01	0.2097E+01
0.2426E+01	0.2758E+01	0.3093E+01	0.3432E+01	0.3774E+01	0.4118E+01
0.4474E+01	0.4824E+01	0.5185E+01	0.5552E+01	0.5921E+01	0.6293E+01
0.6677E+01	0.7059E+01	0.7444E+01	0.7837E+01	0.8232E+01	0.8626E+01
0.9027E+01					

\*\*\*WAVES AND STRONG CURRENT OVER AN UNEVEN BOTTOM\*\*\*

UINF= 0.1000E+01

DEPTH PROFILE:

0.1040E+01	0.1080E+01	0.1120E+01	0.1160E+01	0.1200E+01	0.1240E+01
0.1280E+01	0.1320E+01	0.1360E+01	0.1400E+01	0.1440E+01	0.1480E+01
0.1520E+01	0.1560E+01	0.1600E+01	0.1640E+01	0.1680E+01	0.1720E+01
0.1760E+01	0.1800E+01	0.1840E+01	0.1880E+01	0.1920E+01	0.1960E+01
0.2000E+01					

MEAN FREE SURF. DUE TO THE CURRENT:

0.1181E+01	0.1270E+01	0.1344E+01	0.1408E+01	0.1469E+01	0.1525E+01
0.1580E+01	0.1633E+01	0.1684E+01	0.1734E+01	0.1783E+01	0.1831E+01
0.1878E+01	0.1925E+01	0.1971E+01	0.2017E+01	0.2062E+01	0.2107E+01
0.2152E+01	0.2196E+01	0.2241E+01	0.2284E+01	0.2328E+01	0.2371E+01
0.2414E+01					

PERIOD. T= 0.1000E+01

WAVENUMBER:

0.2038E+01	0.2140E+01	0.2223E+01	0.2294E+01	0.2360E+01	0.2420E+01
0.2477E+01	0.2532E+01	0.2584E+01	0.2633E+01	0.2682E+01	0.2728E+01
0.2773E+01	0.2817E+01	0.2860E+01	0.2901E+01	0.2942E+01	0.2982E+01
0.3021E+01	0.3059E+01	0.3096E+01	0.3133E+01	0.3169E+01	0.3204E+01
0.3239E+01					

GROUP VELOC. IN FIX. FRA.:

0.1221E+01	0.1144E+01	0.1089E+01	0.1047E+01	0.1010E+01	0.9799E+00
0.9526E+00	0.9279E+00	0.9059E+00	0.8855E+00	0.8666E+00	0.8490E+00
0.8329E+00	0.8175E+00	0.8030E+00	0.7894E+00	0.7764E+00	0.7641E+00
0.7523E+00	0.7412E+00	0.7304E+00	0.7203E+00	0.7105E+00	0.7011E+00
0.6920E+00					

CG/SIGMA, COEF. OF EQUATION Y2, Y3:

0.8623E+00	0.7851E+00	0.7321E+00	0.6921E+00	0.6584E+00	0.6303E+00
------------	------------	------------	------------	------------	------------

0.6055E+00	0.5833E+00	0.5637E+00	0.5458E+00	0.5293E+00	0.5140E+00
0.5007E+00	0.4871E+00	0.4748E+00	0.4634E+00	0.4527E+00	0.4425E+00
0.4328E+00	0.4238E+00	0.4151E+00	0.4069E+00	0.3991E+00	0.3916E+00
0.3845E+00					
0.1546E+00	0.1726E+00	0.1874E+00	0.2012E+00	0.2158E+00	0.2308E+00
0.2469E+00	0.2642E+00	0.2823E+00	0.3015E+00	0.3217E+00	0.3429E+00
0.3645E+00	0.3872E+00	0.4107E+00	0.4347E+00	0.4595E+00	0.4848E+00
0.5110E+00	0.5375E+00	0.5647E+00	0.5924E+00	0.6206E+00	0.6495E+00
0.6791E+00					
0.5267E+01	0.7025E+01	0.8631E+01	0.1015E+02	0.1170E+02	0.1321E+02
0.1476E+02	0.1634E+02	0.1792E+02	0.1953E+02	0.2118E+02	0.2287E+02
0.2454E+02	0.2628E+02	0.2806E+02	0.2984E+02	0.3168E+02	0.3353E+02
0.3542E+02	0.3733E+02	0.3929E+02	0.4125E+02	0.4325E+02	0.4529E+02
0.4737E+02					

PERIOD. T= 0.1500E+01

WAVENUMBER:

0.1232E+01	0.1279E+01	0.1317E+01	0.1349E+01	0.1380E+01	0.1409E+01
0.1436E+01	0.1462E+01	0.1487E+01	0.1511E+01	0.1535E+01	0.1558E+01
0.1579E+01	0.1603E+01	0.1622E+01	0.1643E+01	0.1663E+01	0.1682E+01
0.1702E+01	0.1721E+01	0.1739E+01	0.1757E+01	0.1775E+01	0.1792E+01
0.1809E+01					

GROUP VELOC. IN FIX. FRA.:

0.1409E+01	0.1320E+01	0.1255E+01	0.1203E+01	0.1158E+01	0.1120E+01
0.1095E+01	0.1056E+01	0.1029E+01	0.1004E+01	0.9813E+00	0.9606E+00
0.9417E+00	0.9240E+00	0.9075E+00	0.8922E+00	0.8778E+00	0.8642E+00
0.8513E+00	0.8393E+00	0.8277E+00	0.8168E+00	0.8064E+00	0.7964E+00
0.7869E+00					

CG/SIGMA, COEF. OF EQUATION Y2, Y3:

0.1340E+01	0.1213E+01	0.1126E+01	0.1059E+01	0.1003E+01	0.9566E+00
0.9161E+00	0.8804E+00	0.8492E+00	0.8210E+00	0.7955E+00	0.7722E+00
0.7513E+00	0.7318E+00	0.7137E+00	0.6970E+00	0.6814E+00	0.6668E+00
0.6539E+00	0.6401E+00	0.6279E+00	0.6164E+00	0.6055E+00	0.5950E+00
0.5851E+00					
0.9989E-01	0.1228E+00	0.1415E+00	0.1571E+00	0.1711E+00	0.1832E+00
0.1912E+00	0.2042E+00	0.2132E+00	0.2218E+00	0.2300E+00	0.2379E+00
0.2456E+00	0.2535E+00	0.2615E+00	0.2697E+00	0.2782E+00	0.2871E+00
0.2963E+00	0.3059E+00	0.3159E+00	0.3264E+00	0.3371E+00	0.3484E+00
0.3600E+00					
0.2570E+00	0.6955E+00	0.1060E+01	0.1384E+01	0.1704E+01	0.2012E+01
0.2321E+01	0.2634E+01	0.2942E+01	0.3259E+01	0.3580E+01	0.3904E+01
0.4227E+01	0.4561E+01	0.4898E+01	0.5237E+01	0.5581E+01	0.5930E+01
0.6284E+01	0.6640E+01	0.7001E+01	0.7367E+01	0.7732E+01	0.8103E+01
0.8477E+01					

\*\*\*WAVES AND STRONG CURRENT OVER AN UNEVEN BOTTOM\*\*\*

UINF= 0.1050E+01

DEPTH PROFILE:

0.1038E+01	0.1078E+01	0.1118E+01	0.1158E+01	0.1198E+01	0.1238E+01
0.1278E+01	0.1318E+01	0.1358E+01	0.1398E+01	0.1438E+01	0.1478E+01
0.1518E+01	0.1558E+01	0.1598E+01	0.1638E+01	0.1678E+01	0.1718E+01
0.1758E+01	0.1798E+01	0.1838E+01	0.1878E+01	0.1918E+01	0.1958E+01
0.1998E+01					

MEAN FREE SURF.DUE TO THE CURRENT:

0.8814E+00	0.8312E+00	0.7937E+00	0.7625E+00	0.7375E+00	0.7172E+00
0.6984E+00	0.6812E+00	0.6656E+00	0.6516E+00	0.6391E+00	0.6266E+00
0.6156E+00	0.6047E+00	0.5953E+00	0.5859E+00	0.5781E+00	0.5695E+00
0.5617E+00	0.5539E+00	0.5469E+00	0.5406E+00	0.5336E+00	0.5273E+00
0.5211E+00					

PERIOD.T= 0.1000E+01

WAVENUMBER:

0.1630E+01	0.1567E+01	0.1522E+01	0.1484E+01	0.1454E+01	0.1429E+01
0.1495E+01	0.1383E+01	0.1363E+01	0.1345E+01	0.1329E+01	0.1312E+01
0.1298E+01	0.1283E+01	0.1270E+01	0.1257E+01	0.1247E+01	0.1235E+01
0.1224E+01	0.1213E+01	0.1202E+01	0.1193E+01	0.1183E+01	0.1174E+01
0.1165E+01					

GROUP VELOC.IN FIX.FRA.:

0.1678E+01	0.1778E+01	0.1855E+01	0.1923E+01	0.1980E+01	0.2029E+01
0.2076E+01	0.2120E+01	0.2161E+01	0.2200E+01	0.2235E+01	0.2272E+01
0.2304E+01	0.2337E+01	0.2367E+01	0.2397E+01	0.2422E+01	0.2451E+01
0.2478E+01	0.2505E+01	0.2530E+01	0.2552E+01	0.2578E+01	0.2602E+01
0.2626E+01					

CG/SIGMA, COEF. OF EQUATION Y2, Y3:

0.1390E+01	0.1529E+01	0.1644E+01	0.1752E+01	0.1847E+01	0.1932E+01
0.2017E+01	0.2100E+01	0.2181E+01	0.2260E+01	0.2333E+01	0.2411E+01
0.2483E+01	0.2559E+01	0.2627E+01	0.2699E+01	0.2761E+01	0.2833E+01
0.2900E+01	0.2971E+01	0.3033E+01	0.3099E+01	0.3170E+01	0.3236E+01
0.3305E+01					
0.6794E-01	0.5470E-01	0.4590E-01	0.3905E-01	0.3324E-01	0.3006E-01
0.2670E-01	0.2381E-01	0.2136E-01	0.1928E-01	0.1755E-01	0.1591E-01
0.1456E-01	0.1329E-01	0.1226E-01	0.1129E-01	0.1052E-01	0.9711E-02
0.3015E-02	0.8355E-02	0.7791E-02	0.7312E-02	0.6799E-02	0.6365E-02
0.5950E-02					
0.3725E+00	-0.2975E+00	-0.7925E+00	-0.1228E+01	-0.1602E+01	-0.1927E+01
-0.2246E+01	-0.2561E+01	-0.2866E+01	-0.3159E+01	-0.3440E+01	-0.3738E+01
-0.4016E+01	-0.4313E+01	-0.4579E+01	-0.4871E+01	-0.5119E+01	-0.5413E+01
-0.5692E+01	-0.5989E+01	-0.6273E+01	-0.6534E+01	-0.6847E+01	-0.7140E+01
-0.7413E+01					

PERIOD.T= 0.1500E+01

WAVENUMBER:

0.1035E+01	0.1002E+01	0.9795E+00	0.9592E+00	0.9424E+00	0.9284E+00
0.9151E+00	0.9027E+00	0.8911E+00	0.8806E+00	0.8709E+00	0.8611E+00
0.8524E+00	0.8435E+00	0.8358E+00	0.8280E+00	0.8214E+00	0.8140E+00
0.8072E+00	0.8003E+00	0.7940E+00	0.7884E+00	0.7820E+00	0.7763E+00
0.7706E+00					

GROUP VELOC.IN FIX.FRA.:

0.1857E+01	0.1945E+01	0.2011E+01	0.2069E+01	0.2118E+01	0.2159E+01
0.2199E+01	0.2237E+01	0.2273E+01	0.2306E+01	0.2336E+01	0.2368E+01
0.2396E+01	0.2425E+01	0.2451E+01	0.2477E+01	0.2500E+01	0.2525E+01
0.2549E+01	0.2574E+01	0.2596E+01	0.2617E+01	0.2640E+01	0.2661E+01
0.2683E+01					

CG/SIGMA, COEF. OF EQUATION Y2, Y3:

0.2148E+01	0.2150E+01	0.2518E+01	0.2675E+01	0.2814E+01	0.2937E+01
0.3060E+01	0.3182E+01	0.3300E+01	0.3414E+01	0.3521E+01	0.3635E+01
0.3741E+01	0.3852E+01	0.3952E+01	0.4057E+01	0.4149E+01	0.4254E+01
0.4354E+01	0.4458E+01	0.4556E+01	0.4647E+01	0.4752E+01	0.4850E+01

0.4951E+01						
0.2963E-01	0.2258E-01	0.1830E-01	0.1515E-01	0.1290E-01	0.1124E-01	
0.9849E-02	0.8673E-02	0.7697E-02	0.6880E-02	0.6213E-02	0.5588E-02	
0.5079E-02	0.4604E-02	0.4226E-02	0.3896E-02	0.3586E-02	0.3295E-02	
0.3044E-02	0.2810E-02	0.2614E-02	0.2443E-02	0.2263E-02	0.2112E-02	
0.1969E-02						
-0.1612E+01	-0.2108E+01	-0.2531E+01	-0.2946E+01	-0.3327E+01	-0.3681E+01	
-0.4042E+01	-0.4403E+01	-0.4778E+01	-0.5134E+01	-0.5499E+01	-0.5878E+01	
-0.6237E+01	-0.6630E+01	-0.7002E+01	-0.7373E+01	-0.7720E+01	-0.8120E+01	
-0.8502E+01	-0.8923E+01	-0.9349E+01	-0.9699E+01	-0.1014E+02	-0.1057E+02	
-0.1101E+02						

Appendix E: Computer Program (CMS)

```

COMPLEX A(71,140)
DIMENSION H(51),XHI(51),KA(51),Y1(50),Y2(50),Y3(50)
S,CGG(50),ERR(140)
REAL KA,CAA,L
C A=AMPL.;H=DEPTH;XHI=TOTAL DEPTH(WITH CURRENT);
C KA=WAVE NUMBER;Y1,Y2,Y3=COEF.OF EQUA.GOVER.A;
C CGG=GROUP VELOC.IN FIXED FRAME;
C ERR=CONSERVED QUANTITY(FIRST EVOLU.LAW)
NA=140
JA1=35
JA=2*JA1
C NA AND JA ARE DIMEN.OF MATRIX A(AMPLIT.)
NAV=50
NA1=50
DH1=-0.1
DH2=0.
JU=0
C NAV,NA1,DH1,DH2,JU ARE PARAM.OF DEPTH PROFILE
L=0.5
DX=L/FLOAT(NAV-1)
JAA=10
T=3.
TETA =1.
OME=2.+3.14159/T
DTO=TETA/FLOAT(JAA)
L=LENGTH(IN X2 ADIM.VARIA.)OF ZO.OF DEPTH CHANGE
C AMPL.IS STUD.FOR X2=0.TO NA*L
C T=ADIM.PERIOD
C DX,DTO ARE WIDTH OF DISCR.INTER
UINF=0.4
X=(UINF**2)/2.
HC=(X/4.)**0.3333
HC=3.*HC-X
CALL DEPTH(NAV,NA1,JU,DH1,DH2,H)
DO 1 I=1,NAV
HH=H(I)
IF(UINF.LE.0.0001) GO TO 10
CALL MEAFS(HH,UINF,XHII)
XHI(I)=XHII
GO TO 11
10 XHII=H(I)
XHI(I)=XHII
11 CALL WAVENU(OME,UINF,XHII,CAA)
KA(I)=CAA
1 CONTINUE
KA(NAV+1)=KA(NAV)
XHI(NAV+1)=XHI(NAV)
CALL COEFF(NAV,XHI,KA,H,UINF,OME,DX,Y1,Y2,Y3,CGG,XX)
Y21=Y2(1)
CALL INIT(JA,JA1,DTO,Y21,A,IS,ERR)
C GIVES INITIAL PROFILE AT X2=0.
CALL SOLUT(NA,NA1,JA,DX,DTO,Y1,Y2,Y3,IS,A,ERR)
C IF IP=0 WE WANT ONLY NUM.RES.; IF IP=1 WE WANT PLOT
IP=1
IF(IP.EQ.0) CALL IMPRES(UINF,HC,T,JA,NA,NAV,DX,DTO,H,KA,X

```

```

FRA00010
FRA00020
FRA00030
FRA00040
FRA00050
FRA00060
FRA00070
FRA00080
FRA00090
FRA00100
FRA00110
FRA00120
FRA00130
FRA00140
FRA00150
FRA00160
FRA00170
FRA00180
FRA00190
FRA00200
FRA00210
FRA00220
FRA00230
FRA00240
FRA00250
FRA00260
FRA00270
FRA00280
FRA00290
FRA00300
FRA00310
FRA00320
FRA00330
FRA00340
FRA00350
FRA00360
FRA00370
FRA00380
FRA00390
FRA00400
FRA00410
FRA00420
FRA00430
FRA00440
FRA00450
FRA00460
FRA00470
FRA00480
FRA00490
FRA00500
FRA00510
FRA00520
FRA00530
FRA00540
FRA00550

```

```

SHI,XX,Y1,Y2,Y3,CGG,A,IS,ERR,J)
IF(IP.EQ.1) CALL DESSIN(NA,JA,A)
STOP
END
SUBROUTINE DEPTH(NAV,NA1,JJ,DH1,DH2,H)
DIMENSION H(1)
IF(JJ.NE.0) GO TO 10
C IF JJ=0 STEPS;IF JJ NOT EQ.0 JJ ONDULATION OF AMPL.DH1
NA2=NAV-NA1
IF(NA2.EQ.0) DH2=DH1
C IF NA2=0 1 STEP OF HIGH DH1;IF NO 2 STEPS OF HIGH DH1,DH2
DO 1 N=1,NAV
IF(N.GT.NA1) GO TO 100
R=FLOAT(N-1)*3.14159/FLOAT(NA1-1)
H(N)=1.+DH1*(COS(R)-1.)/2.
GO TO 1
100 R=FLOAT(N-NA1)+3.14159/FLOAT(NA2)
H(N)=1.-DH1+(DH2-DH1)*(COS(R)-1.)/2.
1 CONTINUE
GO TO 200
10 DO 2 N=1,NAV
R=2.*FLOAT(JJ)+FLOAT(N-1)*3.14159/FLOAT(NA1-1)
H(N)=1.-DH1*(COS(R)-1.)
2 CONTINUE
200 H(NAV+1)=H(NAV)
RETURN
END
SUBROUTINE MEAFS(HH,UINF,XHII)
EPSI=0.001
A2=(UINF**2)/2.
X2=(A2**2)+4.*A2
X1=(A2-SQRT(X2))/2.
X2=(A2+SQRT(X2))/2.
DELT=0.25*ABS(1.-X2)
IF(DELT.LE.0.05) DELT=0.05
XHII=1.
N=0
Z=HH-1.
ER=ABS(Z)
IF(ER.LE.EPSI) GO TO 20
PTE=2.*(HH-1)-(1.-X1)*(1.-X2)
IF(HH.LT.1.) GO TO 1
IF(UINF.GT.1.) GO TO 10
GO TO 11
12 IF(UINF.LT.1..AND.Z1.LE.0.) DELT=DELT/2.
IF(UINF.GE.1..AND.Z1.GT.0.) DELT=DELT/2.
N=N+1
IF(N.GT.500) GO TO 20
11 XHII=XHII+DELT
GO TO 14
13 IF(UINF.LT.1..AND.Z1.GT.0.) DELT=DELT/2.
IF(UINF.GE.1..AND.Z1.LE.0.) DELT=DELT/2.
N=N+1
IF(N.GT.500) GO TO 20
10 XHII=XHII-DELT

```

```

FRA00560
FRA00570
FRA00580
FRA00590
FRA00600
FRA00610
FRA00620
FRA00630
FRA00640
FRA00650
FRA00660
FRA00670
FRA00680
FRA00690
FRA00700
FRA00710
FRA00720
FRA00730
FRA00740
FRA00750
FRA00760
FRA00770
FRA00780
FRA00790
FRA00800
FRA00810
FRA00820
FRA00830
FRA00840
FRA00850
FRA00860
FRA00870
FRA00880
FRA00890
FRA00900
FRA00910
FRA00920
FRA00930
FRA00940
FRA00950
FRA00960
FRA00970
FRA00980
FRA00990
FRA01000
FRA01010
FRA01020
FRA01030
FRA01040
FRA01050
FRA01060
FRA01070
FRA01080
FRA01090
FRA01100

```



```

14  Z1=Z
    Z=(XHII-1.)*(XHII-X1)*(XHII-X2)
    Z=(HH-1.)*(XHII**2)-Z
    ER=ABS(Z)
    IF(ER.LE.EPSI) GO TO 20
    IF(Z.GE.0..AND.UINF.LT.1.) GO TO 12
    IF(Z.LE.0.,AND.UINF.LT.1.) GO TO 13
    IF(Z.LE.0..AND.UINF.GE.1.) GO TO 12
    IF(Z.GE.0..AND.UINF.GE.1.) GO TO 13
    GO TO 20
1   IF(UINF.GT.1.) GO TO 15
    GO TO 16
17  IF(UINF.GE.1.AND.(Z1.GT.0..OR.PT1.LE.0.)) DELT=DELT/2.
    IF(UINF.LT.1.AND.Z1.LE.0.AND.PT1.LE.0.) DELT=DELT/2.
    N=N+1
    IF(N.GT.500) GO TO 20
15  XHII=XHII+DELT
    GO TO 18
19  IF(UINF.GE.1.AND.Z1.LE.0.AND.PT1.GT.0.) DELT=DELT/2.
    IF(UINF.LT.1.AND.(Z1.GT.0..OR.PT1.GT.0.)) DELT=DELT/2.
    N=N+1
    IF(N.GT.500) GO TO 20
16  XHII=XHII-DELT
18  Z1=Z
    PT1=PTE
    Z=(XHII-1.)*(XHII-X1)*(XHII-X2)
    Z=(HH-1.)*(XHII**2)-Z
    ER=ABS(Z)
    IF(ER.LE.EPSI) GO TO 20
    PTE=2.*(HH-1.)*XHII-(XHII-X1)*(XHII-X2)-(XHII-1.)*(2.*XHII
SI-X1-X2)
    IF((Z.GT.0..OR.PTE.LE.0.)AND.UINF.GE.1.) GO TO 19
    IF(Z.LE.0..AND.PTE.GT.0..AND.UINF.GE.1.) GO TO 17
    IF(Z.LE.0..AND.PTE.LE.0..AND.UINF.LT.1.) GO TO 19
    IF((Z.GT.0..OR.PTE.GT.0.)AND.UINF.LT.1.) GO TO 17
20  RETURN
    END
    SUBROUTINE WAVENU(OME,UINF,XHII,CAA)
    REAL K1,K2,CAA,K1INF,K2INF
    EPSI=0.0001
    X1=1.
    X2=1.
    X3=0.
C   IF X1=1.(RES.-1.),X2=1.(RES.0.),X3=0.(RES.1.),WE STUD.THE
C   SMALLEST(RES.LARGEST)ROOT
    UN=UINF/XHII
    N=0
C   APPROXI.PLAC.OF ROOTS
    K1=14.
1   K1=K1/2.
    FMG=(OME**2)/K1-2.*UN*OME+(UN**2)*K1-TANH(K1*XHII)
    PTE=UN**2-(OME/K1)**2-XHII/((CDSH(K1*XHII))**2)
    IF(FMG.LE.0..OR.PTE.GT.0.) GO TO 1
    DELT=K1
    K2=K1

```

```

FRA01110
FRA01120
FRA01130
FRA01140
FRA01150
FRA01160
FRA01170
FRA01180
FRA01190
FRA01200
FRA01210
FRA01220
FRA01230
FRA01240
FRA01250
FRA01260
FRA01270
FRA01280
FRA01290
FRA01300
FRA01310
FRA01320
FRA01330
FRA01340
FRA01350
FRA01360
FRA01370
FRA01380
FRA01390
FRA01400
FRA01410
FRA01420
FRA01430
FRA01440
FRA01450
FRA01460
FRA01470
FRA01480
FRA01490
FRA01500
FRA01510
FRA01520
FRA01530
FRA01540
FRA01550
FRA01560
FRA01570
FRA01580
FRA01590
FRA01600
FRA01610
FRA01620
FRA01630
FRA01640
FRA01650

```

```

2   FMG=(OME**2)/K2-2.*UN*OME+(UN**2)*K2-TANH(K2*XHII)
   IF(FMG.LE.0.) GO TO 10
   PTE=UINF**2-(OME/K2)**2-XHII/((COSH(K2*XHII))**2)
   IF(PTE.GT.0.) GO TO 11
   K2=K2+DELT
   GO TO 2
11  DELT=DELT/2.
   K2=K2-DELT
   GO TO 2
10  K1INF=K2-DELT
   FMG=1.
   IF(X1.GE.0.) GO TO 131
12  K2=K2+DELT
   FMG=OME**2/K2-2.*UN*OME+(UN**2)*K2-TANH(K2*XHII)
   IF(FMG.LE.0.) GO TO 12
   K2INF=K2
C   AT THIS PT.THE 2 ROOTS ARE K1(K2)BETW. K1INF AND K1INF+DE
C   LT.(K2INF)
131 K2=X2*K1INF+X3*K2INF
   GO TO 130
13  IF(FM1.LE.0.) DELT=DELT/2.
130 K2=K2+X1*DELT
   N=N+1
   IF(N.GT.50) GO TO 1000
   GO TO 15
14  IF(FM1.GT.0.) DELT=DELT/2.
   K2=K2-X1*DELT
   N=N+1
   IF(N.GT.50) GO TO 1000
15  FM1=FMG
   FMG=(OME**2)/K2-2.*UN*OME+(UN**2)*K2-TANH(K2*XHII)
   ER=ABS(FMG)
   IF(FMG.GE.0..AND.ER.GT.EPSI) GO TO 13
   IF(FMG.LT.0..AND.ER.GT.EPSI) GO TO 14
   KAA=K2
1000 RETURN
   END
   SUBROUTINE COEFF(NAV,XHI,KA,H,UINF,OME,DX,Y1,Y2,Y3,CGG,XX)
   DIMENSION XHI(1),KA(1),Y1(1),Y2(1),Y3(1),H(1),CGG(1)
   REAL KA,KX1,KX,KH
   DO 1 N=1,NAV
   UN=UINF/XHI(N)
   C=-UN+(OME/KA(N))
   KX=KA(N)*XHI(N)
   BET=TANH(KX)
   CO=COSH(KX)
   SI=SINH(KX)
   CGM=C*0.5*(1.+KX/(SI*CO))
   CG=CGM+UN
   CGG(N)=CG
   Y2(N)=1.-XHI(N)*(1.-BET*BET)*(1.-BET*KX)/(CGM**2)
   Y2(N)=Y2(N)*(CGM**2)*KA(N)/(2.*C*(CG**3))
   Y3(N)=4.*((C/CGM)**2)+4.*C/(CGM*CO*CO)+XHI(N)/((CGM*CO*CO)**2)
   Y3(N)=-2.*Y3(N)*((BET*CGM)**2)/(XHI(N)-(CGM**2))+9.-10.*(
SBET**2)+9.*(BET**4)

```

```

FRA01660
FRA01670
FRA01680
FRA01690
FRA01700
FRA01710
FRA01720
FRA01730
FRA01740
FRA01750
FRA01760
FRA01770
FRA01780
FRA01790
FRA01800
FRA01810
FRA01820
FRA01830
FRA01840
FRA01850
FRA01860
FRA01870
FRA01880
FRA01890
FRA01900
FRA01910
FRA01920
FRA01930
FRA01940
FRA01950
FRA01960
FRA01970
FRA01980
FRA01990
FRA01990
FRA02000
FRA02010
FRA02020
FRA02030
FRA02040
FRA02050
FRA02060
FRA02070
FRA02080
FRA02090
FRA02100
FRA02110
FRA02120
FRA02130
FRA02140
FRA02150
FRA02160
FRA02170
FRA02180
FRA02190
FRA02200

```

```

Y3(N)=KA(N)*Y3(N)/(4.*CG+C*((C*BET)**2))
XX=ABS(Y3(1))
IF(N.GT.1) Y3(N)=Y3(N)/XX
KX1=KA(N+1)*XHI(N+1)
CG10S=0.5*(1.+KX1/(SINH(KX1)*COSH(KX1)))/KA(N+1)
CG10S=CG10S+UINF/(XHI(N+1)*(OME-UINF+KA(N+1)/XHI(N+1)))
Y1(N)=(CG10S-CG/(C*KA(N)))/DX
Y1(N)=Y1(N)/(CG10S+CG/C*KA(N))
1 CONTINUE
Y3(1)=Y3(1)/XX
C Y3(N) IS NORMALI.SUCH THAT ABS(Y3(1))=1.
RETURN
END
SUBROUTINE INIT(JA,JA1,DTO,Y21,A,IS,ERR)
COMPLEX A(71,1)
DIMENSION ERR(1)
IS=1
C IF IS=1 INIT.PROF.SYMET.IN TO
C IF IS=1 GIVE A AT X2=0 FOR TO=-DTO TO JA+DTO
C IF IS=0 INIT.PROF.NOT SYMET.IN TO
QQ=2.
W=QQ/SQRT(2.*Y21)
JA2=JA+1
E=0.
DO 1 I=1,JA2
R=FLOAT(I-2)
A(I,1)=CMPLX(QQ/COSH(W*R*DTO),0.)
IF(I.LE.2) GO TO 1
E=E+CABS(A(I,1))**2+CABS(A(I-1,1))**2
1 CONTINUE
ERR(1)=E*DTO/2.
RETURN
END
SUBROUTINE SOLUT(NA,NAV,JA,DX,DTO,Y1,Y2,Y3,IS,A,ERR)
COMPLEX AL(200),BE(200),GA(200),W(200),X(200),Y(200),
SA(71,1)
DIMENSION Y1(1),Y2(1),Y3(1),ERR(1)
C IF IS=0 A IS NOT SYMET.IN TO
C IF IS=1 A IS SYMET.IN TO
JA1=JA-1
YY=0.
KK=3-IS
DO 1 I=2,NA
E=0.
A(JA+1,I)=CMPLX(0.,0.)
IF(IS.EQ.0) A(1,I)=CMPLX(0.,0.)
IF(I.GT.NAV) GO TO 100
Y11=Y1(I-1)
Y22=Y2(I-1)
Y33=Y3(I-1)
Y11=(Y1(I-1)+Y1(I))/2.
Y22=(Y2(I-1)+Y2(I))/2.
Y33=(Y3(I-1)+Y3(I))/2.
GO TO 101
100 IF(I.GT.(NAV+1)) GO TO 101

```

```

FRA02210
FRA02220
FRA02230
FRA02240
FRA02250
FRA02260
FRA02270
FRA02280
FRA02290
FRA02300
FRA02310
FRA02320
FRA02330
FRA02340
FRA02350
FRA02360
FRA02370
FRA02380
FRA02390
FRA02400
FRA02410
FRA02420
FRA02430
FRA02440
FRA02450
FRA02460
FRA02470
FRA02480
FRA02490
FRA02500
FRA02510
FRA02520
FRA02530
FRA02540
FRA02550
FRA02560
FRA02570
FRA02580
FRA02590
FRA02600
FRA02610
FRA02620
FRA02630
FRA02640
FRA02650
FRA02660
FRA02670
FRA02680
FRA02690
FRA02700
FRA02710
FRA02720
FRA02730
FRA02740
FRA02750

```

```

Y111=0.
Y222=Y2(NAV)
Y333=Y3(NAV)
Y11=0.
Y22=Y222
Y33=Y333
101 DO 2 J=1,JA1
S=CABS(A(J+1,I-1))
AL(J)=CMPLX(0.,Y22*DX/(2.*(DTO**2)))
GA(J)=AL(J)
W(J)=A(J+1,I-1)*CMPLX(1.-DX*Y11/2.,DX*Y22/(DTO**2)-Y33*S*
SS*DX/2.)
W(J)=W(J)-(A(J+2,I-1)+A(J,I-1))*AL(J)
BE(J)=A(J+1,I-1)*CMPLX(1.-DX*Y111,DX*2.*Y222/(DTO**2)-Y33
S3*S*S*DX)
BE(J)=BE(J)-(A(J+2,I-1)+A(J,I-1))*CMPLX(0.,Y222*DX/(DTO**
S2))
S=CABS(BE(J))
BE(J)=CMPLX(1.+DX*Y11/2.,-DX*Y22/(DTO**2)+DX*Y33*S*S/2.)
2 CONTINUE
X(JA-1)=-AL(JA-1)/BE(JA-1)
Y(JA-1)=W(JA-1)/BE(JA-1)
DO 3 J=3,JA
K=JA+1-J
X(K)=-AL(K)/(GA(K)*X(K+1)+BE(K))
Y(K)=(W(K)-GA(K)*Y(K+1))/(GA(K)*X(K+1)+BE(K))
3 CONTINUE
IF(IS.EQ.0) A(2,I)=(W(1)-GA(1)*Y(2))/(GA(1)*X(2)+BE(1))
IF(IS.EQ.1) A(1,I)=(X(2)*Y(1)+Y(2))/(1.-X(2)*X(1))
DO 4 J=KK,JA
A(J,I)=A(J-1,I)*X(J-1)+Y(J-1)
IF(J.LE.2) GO TO 4.
E=E+CABS(A(J,I))**2+CABS(A(J-1,I))**2
4 CONTINUE
IF(I.GT.NAV) GO TO 103
YY=YY+Y1(I)+Y1(I-1)
103 ERR(1)=0.5*DTO*E*EXP(DX*YY)
1 CONTINUE
RETURN
END
SUBROUTINE IMPRES(UINF,HC,T,JA,NA,NAV,DX,DTO,H,KA,XHI,XX,
SY1,Y2,Y3,CGG,A,IS,ERR,J)
DIMENSION H(1),B(1),XHI(1),Y1(1),Y2(1),Y3(1),CGG(1),ERR(1)
COMPLEX A(71,1)
REAL KA(1)
IF(J.GT.1) GO TO 2000
IF(UINF.LE.0.0001) WRITE (6,501)
IF(UINF.GT.0.0001) WRITE (6,502)
501 FORMAT (5X,'****WAVES OVER AN UNEVEN BOTTOM****',/)
502 FORMAT (/5X,'****WAVES AND STRONG CURRENT OVER AN UNEVEN BOTTOM**
S**',/)
IF(UINF.GT.0.0001) WRITE (6,503) UINF
504 FORMAT (/5X,'PERIOD.T=',E12.4)
503 FORMAT (5X,'UINF=',E12.4,/)
WRITE (6,507)

```

```

FRA02760
FRA02770
FRA02780
FRA02790
FRA02800
FRA02810
FRA02820
FRA02830
FRA02840
FRA02850
FRA02860
FRA02870
FRA02880
FRA02890
FRA02900
FRA02910
FRA02920
FRA02930
FRA02940
FRA02950
FRA02960
FRA02970
FRA02980
FRA02990
FRA03000
FRA03010
FRA03020
FRA03030
FRA03040
FRA03050
FRA03060
FRA03070
FRA03080
FRA03090
FRA03100
FRA03110
FRA03120
FRA03130
FRA03140
FRA03150
FRA03160
FRA03170
FRA03180
FRA03190
FRA03200
FRA03210
FRA03220
FRA03230
FRA03240
FRA03250
FRA03260
FRA03270
FRA03280
FRA03290
FRA03300

```

```

507 FORMAT (5X,'DEPTH PROFILE:')
WRITE (6,508) (H(K),K=1,NAV)
508 FORMAT (6E12.4)
IF(UINF.GT.0.0001) WRITE (6,509)
509 FORMAT (5X,'MEAN FREE SURF.DUE TO THE CURRENT:')
IF(UINF.GT.0.0001) WRITE (6,508) (XHI(K),K=1,NAV)
2000 WRITE (6,504) T
WRITE (6,520)
520 FORMAT (5X,'WAVENUMBER:')
WRITE (6,508) (KA(K),K=1,NAV)
WRITE (6,510)
510 FORMAT (5X,'GROUP VELOC.IN FIX.FRA.:')
WRITE (6,508) (CGG(K),K=1,NAV)
WRITE (6,511)
511 FORMAT (5X,'CG/SIGMA,COEF.OF EQUATION Y2,Y3:')
WRITE (6,508) (Y1(K),K=1,NAV)
WRITE (6,508) (Y2(K),K=1,NAV)
WRITE (6,508) (Y3(K),K=1,NAV)
JJ=0
IF(JJ.EQ.0) GO TO 1000
WRITE (6,513)
513 FORMAT (/5X,'AMPLIT.OF WAVES(*SQRT(XX)):',/)
JA1=JA+1
ISS=IS+1
DO 1 J=1,NA,20
DO 2 L=1,JA1
B(L)=CABS(A(L,J))
2 CONTINUE
WRITE (6,514) J
514 FORMAT (2X,'X=X(',I2,')')
WRITE (6,508) (B(K),K=ISS,JA1)
WRITE (6,515) J,ERR(J)
515 FORMAT (5X,'QUANTITY CONSER.EN(',I3,')=',E12.4)
1 CONTINUE
1000 RETURN
END
SUBROUTINE DESSIN(NA,JA,A)
COMPLEX A(71,1)
DIMENSION B(71,140),SH(302),SV(302)
JA1=JA+1
DO 1 I=1,NA
DO 2 J=1,JA1
B(J,I)=CABS(A(J,I))
2 CONTINUE
1 CONTINUE
BMAX=8.
IDIM=JA1
JDIM=NA
ISTART=2
IDELT=1
ISTOP=50
JSTART=1
JDELTA=2
JSTOP=NA
CALL PLOTS(120,IDUM2,08)

```

```

FRA03310
FRA03320
FRA03330
FRA03340
FRA03350
FRA03360
FRA03370
FRA03380
FRA03390
FRA03400
FRA03410
FRA03420
FRA03430
FRA03440
FRA03450
FRA03460
FRA03470
FRA03480
FRA03490
FRA03500
FRA03510
FRA03520
FRA03530
FRA03540
FRA03550
FRA03560
FRA03570
FRA03580
FRA03590
FRA03600
FRA03610
FRA03620
FRA03630
FRA03640
FRA03650
FRA03660
FRA03670
FRA03680
FRA03690
FRA03700
FRA03710
FRA03720
FRA03730
FRA03740
FRA03750
FRA03760
FRA03770
FRA03780
FRA03790
FRA03800
FRA03810
FRA03820
FRA03830
FRA03840
FRA03850

```

```
CALL PLOT3D(B,BMAX,0.,IDIM,JDIM,ISTART,IDELT,ISTOP,JSTART
S,JDILT,JSTOP,1,45.,45.,SH,SV,'EVOL.OF 2 B.SOLITONS',20,
SO.0,0.0,0.0)
CALL ENDPLT(12.,0.,999)
RETURN
END
```

```
FRA03860
FRA03870
FRA0388C
FRA03890
FRA03900
FRA0391C
```

List of Figures and Captions.

Figure (1) Definition sketch.

Figure (2) Definition sketch.

Figure (3) Critical depth as a function of the current at  $-\infty$

Figure (4) Envelope of a soliton for constant depth  $A(0, \tau) = w \operatorname{sech} \left( 2 \sqrt{\frac{y_3}{2y_2}} \tau \right)$

$U = 0.4 \quad T = 3; |A|$  is plotted for  $x_2 = 0$  to 8.5  $\tau = 0$  to 5.

Figure (5) Envelope of two bounded solitons for constant depth  $A(0, \tau) =$

$2 \operatorname{sech} \left( \sqrt{\frac{y_3}{2y_2}} \tau \right) U = 0.4 \quad T = 3; |A|$  is plotted for  $x_2 = 0$  to

4.2  $\tau = 0$  to 5.

Figure (6) Definition sketch.

Figure (7)  $y_3$  as a function of  $k(\zeta + h)$  for (1)  $U = 0.4 \quad T = 3$ ; (2)  $U = 0.4$   
 $t = 5$ ; (3)  $U = 0.8 \quad T = 5$ .

Figure (8)  $K = \sqrt{\frac{y_3}{2y_2}}$  as a function of  $k$  for (1)  $U = 0 \quad T = 5$ ; (2)  $U = 0.8$

$T = 3$ ; (3)  $U = 0.4 \quad T = 3$ .

Figure (9) Evolution of the envelope of a soliton moving over decreasing

depth;  $A(0, \tau) = 5 \operatorname{sech} \left( 5 \sqrt{\frac{y_3}{2y_2}} \tau \right) U = 0 \quad T = 3 \quad dh = -0.6$

$L = 0.5; |A|$  is plotted for  $x_2 = 0$  to 0.5  $\tau = 0$  to 5.

Figure (10) Evolution of the envelope of a soliton moving over increasing

depth;  $A(0, \tau) = 5 \operatorname{sech} \left( 5 \sqrt{\frac{y_3}{27_2}} \tau \right) U = 0 \quad T = 5 \quad dh = 0.2$

$L = 0.5; |A|$  is plotted for  $x_2 = 0$  to 0.5  $\tau = 0$  to 5.

Figure (11) Evolution of the envelope of a soliton moving over increasing depth;  $A(0, \tau) = 5 \operatorname{sech} \left( 5 \sqrt{\frac{y_3}{2y_2}} \tau \right)$   $U = 0$   $T = 5$   $dh = 0.7$

$L = 0.3$ ;  $|A|$  is plotted for  $x_2 = 0$  to  $0.3$   $\tau = 0$  to  $5$ .

Figure (12) Evolution of the envelope of a soliton moving over decreasing depth;  $A(0, \tau) = 2 \operatorname{sech} \left( 2 \sqrt{\frac{y_3}{2y_2}} \tau \right)$   $U = 0.4$   $T = 3$   $dh = 0.1$

$L = 1$ ;  $|A|$  is plotted for  $x_2 = 0$  to  $5.6$   $\tau = 0$  to  $5$ .

Figure (13) Evolution of the envelope of a soliton moving over increasing depth;  $A(0, \tau) = 2 \operatorname{sech} \left( 2 \sqrt{\frac{y_3}{2y_2}} \tau \right)$   $U = 0.4$   $T = 3$   $dh = 0.1$

$L = 1$ ;  $|A|$  is plotted for  $x_2 = 0$  to  $2.85$   $\tau = 0$  to  $5$ .

Figure (14) Evolution of the envelope of a soliton moving over increasing depth;  $A(0, \tau) = 2 \operatorname{sech} \left( 2 \sqrt{\frac{y_3}{2y_2}} \tau \right)$   $U = 0.4$   $T = 3$   $dh = 0.6$

$L = 3$ ;  $|A|$  is plotted for  $x_2 = 0$  to  $1$   $\tau = 0$  to  $5$ .

Figure (15) Evolution of the envelope of two bounded solitons moving over decreasing depth;  $A(0, \tau) = 2 \operatorname{sech} \left( \sqrt{\frac{y_3}{2y_2}} \tau \right)$   $U = 0.4$

$T = 3$   $dh = -0.1$   $L = 1$ ;  $|A|$  is plotted for  $x_2 = 0$  to  $2.85$   $\tau = 0$  to  $5$ .

Figure (16) Evolution of the envelope of two bounded solitons moving over increasing depth;  $A(0, \tau) = 2 \operatorname{sech} \left( \sqrt{\frac{y_3}{2y_2}} \tau \right)$   $U = 0.4$   $T = 3$

$dh = 0.1$   $L = 0.5$ ;  $|A|$  is plotted for  $x_2 = 0$  to  $1.42$   $\tau = 0$  to  $5$ .



Figure (17) Evolution of a sech profile when  $y_3 < 0$

$$a(0, \tau) = 2 \operatorname{sech} \left( \sqrt{\frac{-y_3}{2y_2}} \tau \right) \quad U = 1.6 \quad dh = -0.2 \quad T = 3$$

$L = 1$ ;  $|A|$  is plotted for  $x_2 = 0$  to 1.9  $\tau = 0$  to 5.

Figure (18) Evolution of a sech profile when  $y_3 < 0$

$$A(0, \tau) = 2 \operatorname{sech} \left( 2 \sqrt{\frac{-y_3}{2y_2}} \tau \right) \quad T = 5 \quad dh = 0.2 \quad L = 1;$$

$|A|$  is plotted for  $x_2 = 0$  to 1.9  $\tau = 0$  to 5.