

copy 3

DOCUMENT ROOM, 26-327
~~DOCUMENT ROOM 36-412~~
RESEARCH LABORATORY OF ELECTRONICS
MASSACHUSETTS INSTITUTE OF TECHNOLOGY
CAMBRIDGE 39, MASSACHUSETTS, U.S.A.

FM WEAKER-SIGNAL SUPPRESSION WITH NARROW-BAND LIMITERS

ROBERT J. McLAUGHLIN

TECHNICAL REPORT 361

FEBRUARY 1, 1960

Loan Copy Only

MASSACHUSETTS INSTITUTE OF TECHNOLOGY
RESEARCH LABORATORY OF ELECTRONICS
CAMBRIDGE, MASSACHUSETTS

The Research Laboratory of Electronics is an interdepartmental laboratory of the Department of Electrical Engineering and the Department of Physics.

The research reported in this document was made possible in part by support extended the Massachusetts Institute of Technology, Research Laboratory of Electronics, jointly by the U. S. Army (Signal Corps), the U.S. Navy (Office of Naval Research), and the U.S. Air Force (Office of Scientific Research, Air Research and Development Command), under Signal Corps Contract DA36-039-sc-78108, Department of the Army Task 3-99-20-001 and Project 3-99-00-000.

MASSACHUSETTS INSTITUTE OF TECHNOLOGY

RESEARCH LABORATORY OF ELECTRONICS

Technical Report 361

February 1, 1960

FM WEAKER-SIGNAL SUPPRESSION WITH NARROW-BAND LIMITERS

Robert J. McLaughlin

This report is based on a thesis submitted to the Department of Electrical Engineering, M.I.T., June 1958, in partial fulfillment of the requirements for the degree of Master of Science.

Abstract

A study has been made of the practical requirements in the design of FM receivers for suppressing cochannel interference by the method of narrow-band limiting. A design procedure specifying sufficient properties for each section of the receiver is presented. The amplitude disturbances that are caused by the interference before and after narrow-band limiting of the resultant signal are evaluated, in order to determine the limiting-threshold requirements for their suppression. The results of an extensive study of the potentialities of the gated-beam limiter are presented, and its suitability for use as a narrow-band limiter is discussed. The report on computational studies is accompanied by an experimental study of receiver performance, and an estimate is made of the effect of deviations of the properties of the various receiver stages from those assumed in ideal theoretical models.

I. INTRODUCTION

The purposes of this report are to present a systematic procedure for the design of an FM receiver for suppressing cochannel interference by the method of narrow-band limiting, and to show what performance may be obtained in practice.

When two signals are present at the input of a receiver there is a disturbance of the instantaneous frequency of the resultant signal about an average value that is equal to the frequency of the stronger signal. With two stationary carriers, the disturbance is periodic at a frequency equal to the difference between the frequencies of the carriers. The problem is to eliminate the disturbance without changing the average value of the instantaneous frequency. If this is done, the stronger signal is "captured."

Baghdady (1, 2) has shown that it is possible to design a chain of amplitude limiters and narrow-band filters so as to preserve the average value of the instantaneous frequency while the disturbance about this value is being strongly attenuated. This procedure is the method of narrow-band limiting.

The computations of the interference-suppression properties of the limiter-filter chain are unavoidably based upon an idealized model of an FM receiver. It is desirable to translate this theoretical description of the receiver into practical specifications that will ensure interference-suppression properties of the receiver which do not differ seriously from the theoretical predictions. These specifications are stated in Section II for each section of the receiver. The most difficult design problem is encountered in the limiter section, largely as a result of the critical limiter-threshold voltage requirements. The suitability of gated-beam limiters for meeting the requirements of a high-capture-ratio receiver is discussed in Section III. Section IV describes a laboratory receiver that was designed on the basis of the computational results of this report, and Section V describes the interference-suppression properties of this receiver.

II. RECEIVER DESIGN REQUIREMENTS

The research outlined in this section is based largely upon theoretical work carried out by Baghdady (1,2). Since the bandpass filters in the limiter section are assumed to be "ideal" (flat amplitude and linear phase within the passband, and infinite attenuation outside the passband), the numerical results of this study can only be used as a guide for practical circuit design.

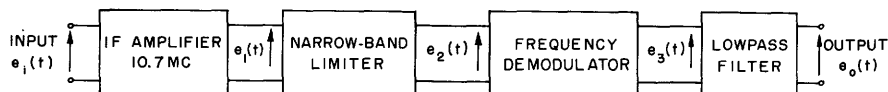

Fig. 1. Block diagram of FM receiver.

For our purposes, an FM receiver may be considered as composed of four sections: a 10.7-mc linear i-f amplifier; a chain of amplitude limiters and narrow bandpass filters; an amplitude-insensitive frequency demodulator; and a lowpass filter and audio amplifier. A block diagram of this receiver is shown in Fig. 1.

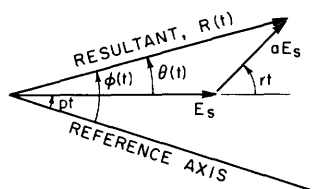

Fig. 2. Phasor diagram of receiver input.

We consider the operation of the receiver when there are two FM signals at the input, the stronger signal being the desired one. If the amplitude of the stronger signal is chosen for reference, the weaker signal will have an amplitude $a < 1$ times as large, where a is the "interference ratio." Operation of the receiver is analyzed by considering the effects in any interval of time during which the frequency difference between the signals is at least a few times the highest modulation frequency of either signal, so that the instantaneous frequencies of the two FM input signals may be considered approximately constant. The receiver input is then given by

$$e_{in}(t) = E_s [\cos pt + a \cos (p+r)t] \quad (1)$$

where $r \ll p$. This signal is represented as the projection on the real axis of the resultant of the two rotating vectors shown in the diagram of Fig. 2. With $a < 1$, it is easily verified that the instantaneous frequency of the signal $e_{in}(t)$ is

$$\frac{d\phi}{dt} = p + \frac{d\theta}{dt} \quad (2)$$

and that its average value is p rad/sec, the frequency of the stronger signal. The design requirements of each section of the receiver will be described.

2.1 I-F AMPLIFIER SECTION

The most important requirement of the i-f amplifier section is that it have a flat frequency characteristic over the frequency range occupied by input signals. The effect of irregularities in the frequency characteristic is to decrease the potential capture performance of the receiver, as the following example illustrates. Suppose that an i-f amplifier with a positive ripple ϵ in its frequency characteristic precedes a limiter-discriminator section that can capture the stronger signal when the interference ratio is less than a_l . If the input signal (Eq. 1) is applied to the receiver input with the frequency $p + r$ falling at the peak of the ripple, the i-f amplifier will deliver the relative amplitudes E_s and $aE_s(1+\epsilon)$ to the limiter-discriminator section. The capture ratio a_m of the entire receiver will be the value of the interference ratio for which the ratio of these two amplitudes is a_l . The over-all capture ratio, therefore, is

$$a_m = \frac{a_l}{1 + \epsilon} \approx a_l - \epsilon \quad (3)$$

for small ϵ and for a near unity. The potential capture ratio is decreased by an amount approximately equal to the ripple.

2.2 LIMITER SECTION

The functions of the limiter section of the receiver are to suppress the interference caused by the weaker input signal, and to supply a constant drive to the frequency demodulator. The first objective is accomplished through the sluggish action of narrow bandpass filters inserted between adjacent limiters, as discussed by Baghdady (1,2). Our concern here, is to discuss the mechanism of this interference suppression only to the

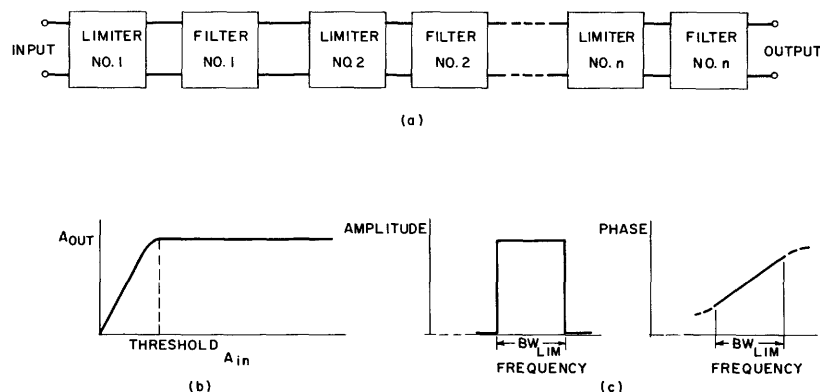

Fig. 3. Characterization of limiter section. (a) Block diagram of n-stage limiter section. (b) Limiter characteristic. (c) Ideal bandpass filter characteristics.

extent of specifying the properties that are necessary for the different parts of the limiter section.

For this purpose, the limiter section is represented by a cascade of amplitude limiters and bandpass filters, as shown in Fig. 3a. An amplitude limiter is assumed to be a device that delivers an output sinusoid of amplitude A_{out} when an input sinusoid of amplitude A_{in} is applied. It is described by its "limiter characteristic," the plot of A_{out} versus A_{in} , as shown in Fig. 3b. An important point on this characteristic is the value of A_{in} at which limiting operation begins, called the "limiting threshold." A bandpass filter is assumed to be a linear filter described by its steady-state frequency-response characteristic, as shown in Fig. 3c.

The first requirement of the limiter section is that the amplitude of the signal at the input of each limiter remain above the limiting threshold at all times. Let us consider what the amplitude at each of these inputs may be.

If the signal $e_{in}(t)$ of Eq. 1 is present at the input of the first limiter, it must be noted that $e_{in}(t)$ fluctuates in amplitude between the limits $1 + a$ and $1 - a$ with a fundamental frequency of r rad/sec. To ensure that this amplitude always remains above the limiting threshold, the threshold must be set at a value less than $(1-a) E_s$.

As the signal passes through the first amplitude limiter, the amplitude variations are removed. The amplitude-limited signal then passes through the first narrow-band filter, and amplitude variations are reintroduced by the sluggish filter action. These amplitude variations are present at the input of the second limiter, and it will be shown that they may be even larger than the variations at the input of the first limiter.

The minimum value of the amplitude of the signal at the output of the first limiter filter can be calculated from data given by Baghdady (2) if the assumption of an ideal bandpass filter characteristic is retained. The spectral components present at the filter output have been computed (2) for various filter bandwidths. By construction of a vector diagram similar to Fig. 2, it can be shown that the amplitude minima occur when the lower sideband components A_n are aligned in the direction of the central component A_0 (at frequency p), and the upper sideband components A_{-n} are aligned in the opposite direction. Thus the minimum value of the signal amplitude is given by

$$R_{min} = \left[\sum_{n=0}^M |A_n| - \sum_{n=1}^N |A_{-n}| \right] E_s \quad (4)$$

with the appropriate values of M and N determined by the filter bandwidth BW_{lim} and the position of p relative to the center of the passband.

This computation has been carried out for various values of the interference ratio \underline{a} and for filter bandwidths of one, two, three, and five times the i-f bandwidth BW_{if} . The minimum amplitudes at both input and output of the first limiter-filter stage are plotted as functions of the interference ratio in Fig. 4. Note that the output minimum amplitude actually reaches the value zero for values \underline{a}_{max} that are less than one. Thus the amplitude fluctuation may be greater at the limiter output than at the input if \underline{a}

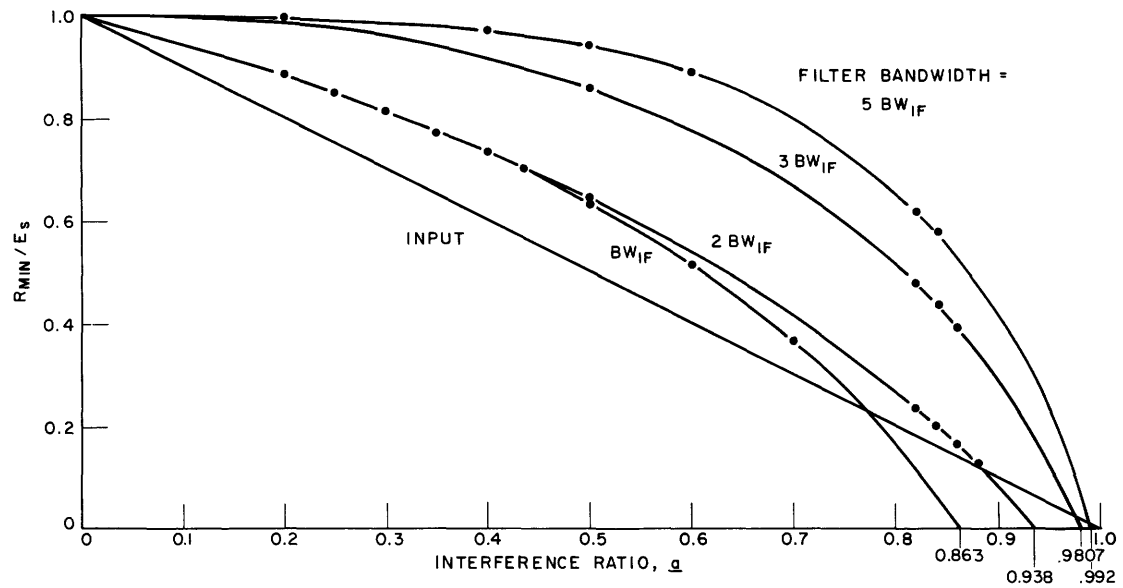

Fig. 4. Minimum amplitude R_{\min} at input and output of narrow-band limiter.

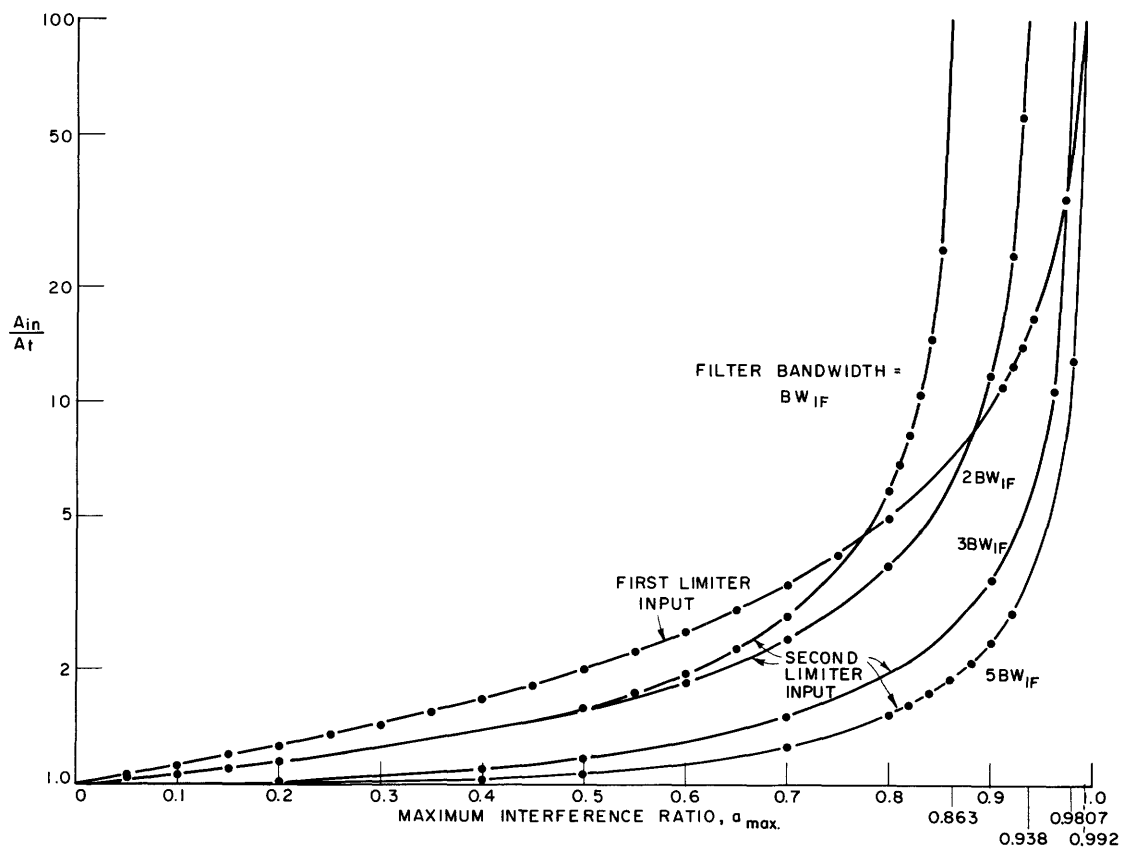

Fig. 5. Amplitude ratio A_{in}/A_t required at input of first or second limiter. (Amplitude at limiting threshold = 1.0.)

has a value approaching a_{\max} .

Computation of the amplitude variation at the output of filters farther along the chain is considerably more difficult; it is complicated by the fact that the variation is dependent not only upon the bandwidth of the filter in question, but also upon the bandwidths of all previous filters in the chain. Therefore the task will not be attempted here. But the following remarks can be made about the variations in some important special cases:

(a) The worst possible variation that can occur at any point in the limiter section is the variation that occurs at the output of the first limiter filter when its bandwidth equals the i-f bandwidth.

(b) If all the filters in the limiter section have the same bandwidth, the amplitude variations are most severe at the output of the first limiter filter, and become less severe at points farther along the chain.

(c) If the filters have larger and larger bandwidths at points farther along the chain, the amplitude variations will decrease in severity along the chain even more rapidly than in case (b).

(d) If the bandwidth of a filter in the chain is less than the bandwidth of the first limiter filter, then there is a possibility that the amplitude variations at the output of that filter may be more severe than at the output of the first filter.

With the help of these remarks, bounds, at least, can be placed upon the amplitude variations at any point in the limiter chain.

Calculation of the performance of the first or second amplitude limiter may be facilitated by a simple test: First, measure the limiting threshold of the limiter stage, for example, by dynamically plotting the limiting characteristic on an oscilloscope. Next, apply a single signal

$$e_{in}(t) = E_s \cos \omega t \quad (5)$$

with amplitude E_s equal to the expected amplitude of the stronger signal in the interference situation. Measure the amplitude, A_{in} , delivered at the input of the first or second limiter, and divide by the threshold amplitude, A_t , of the limiter to obtain an amplitude ratio. Figure 5, which is a plot of the reciprocals of the curves shown in Fig. 4, gives the greatest value of the interference ratio \underline{a} at which a receiver signal

$$e_{in}(t) = E_s [\cos pt + a \cos (p+r) t] \quad (6)$$

will saturate the limiter under the conditions specified on the various curves. In Fig. 5, the threshold amplitude is assigned the ordinate value unity.

The second requirement in the design of the limiter section is that the filter bandwidths be chosen in such a way that the interference caused by the weaker signal is suppressed without disturbing the message carried by the stronger signal. When the two interfering signals of Eq. 1 are present at the receiver input, a disturbance consisting of large fluctuations of the instantaneous frequency of the resultant signal about the desired average value p rad/sec results. In general, the use of narrow filters in the

limiter section will reduce these fluctuations, the reduction becoming greater as the filter bandwidths are made narrower and more limiter-filter stages are added. For a given filter bandwidth, however, there is a critical value a_{\max} of the interference ratio a , which must not be exceeded if the correct average-frequency value is to be preserved. The minimum permissible filter bandwidth is one i-f bandwidth. In this case, $a_{\max} = 0.863$. If larger filter bandwidths are used, a_{\max} is increased. In order to achieve a satisfactory receiver design, it is necessary to choose the filter bandwidths so as to obtain an acceptable value of a_{\max} .

The properties of the system have not been calculated for the general case in which the filter bandwidths are arbitrary. But calculations have been made for a sufficient number of special cases to serve as a guide for approximate design. The following general properties of the limiter-filter chain may be stated:

(a) If the bandwidths of the filters in a limiter-filter chain increase at points farther from the input, the frequency variations will be reduced with the least rapidity as the signal progresses along the chain. The critical interference ratio a_{\max} will be determined by the bandwidth of the first filter.

(b) If the filter bandwidths are all equal, the frequency variations will be reduced more rapidly than in case (a), and a_{\max} will be determined by the bandwidth of the first filter.

(c) If the filter bandwidths decrease in the correct manner along the chain, the frequency variation will be reduced even more rapidly than in case (b), and a_{\max} will be determined by the first-filter bandwidth.

(d) If the filter bandwidths decrease too rapidly along the chain, the frequency variations will not be reduced with the greatest rapidity, and a_{\max} will be determined by the bandwidths of a number of consecutive filters, beginning with the first.

(e) If the bandwidths of any or all filters in the chain are equal to the i-f bandwidth, then $a_{\max} = 0.863$. For interference ratios somewhat smaller than this value (see Fig. 5), the frequency variations are reduced with the greatest rapidity if all filter bandwidths equal the i-f bandwidth.

For interference ratios between zero and a value somewhat less than $a = 0.863$, the most efficient interference reduction scheme is the one described in case (e), with all filter bandwidths equal to the i-f bandwidth. The properties of this system have been computed. A plot of the range of possible values of the instantaneous-frequency fluctuation at the output of the chain is presented in Fig. 6 as a function of a , for various numbers of stages in the chain.

For interference ratios greater than 0.863, the most efficient scheme is the one described in case (c), but it is very difficult to compute the appropriate bandwidths. An acceptable substitute is the scheme of case (b) with equal filter bandwidths somewhat larger than the i-f bandwidth. The results of calculations of the frequency fluctuation at the output of the system for filter bandwidths 3 and 7 times the i-f bandwidth are presented in Figs. 7 and 8.

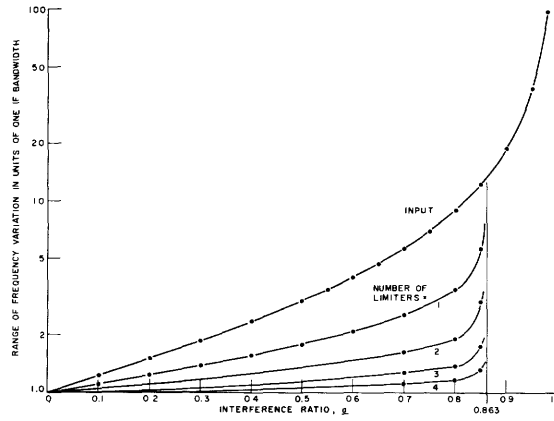

Fig. 6. Possible range of instantaneous-frequency variation at input and output of a cascade of narrow-band limiters, $BW_{lim} = BW_{if}$.

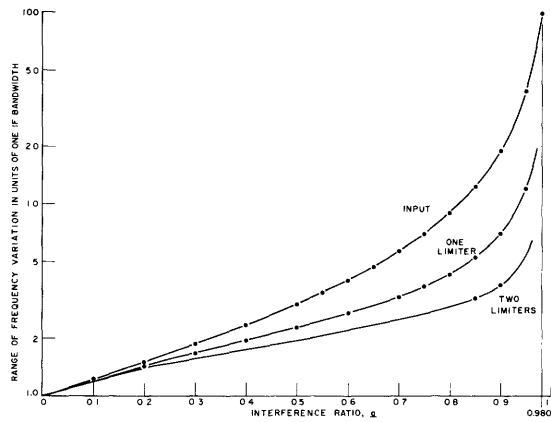

Fig. 7. Possible range of instantaneous-frequency variation at input and output of a cascade of narrow-band limiters, $BW_{lim} = 3BW_{if}$.

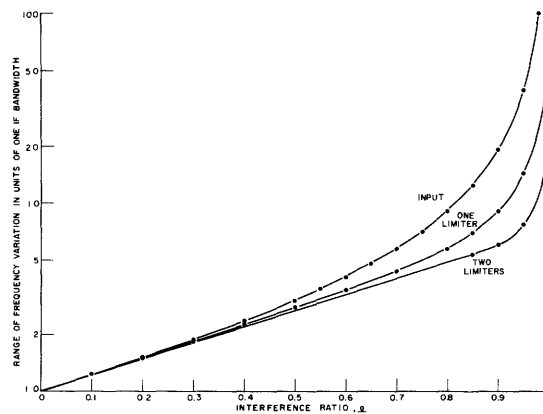

Fig. 8. Possible range of instantaneous-frequency variation at input and output of a cascade of narrow-band limiters, $BW_{lim} = 7BW_{if}$.

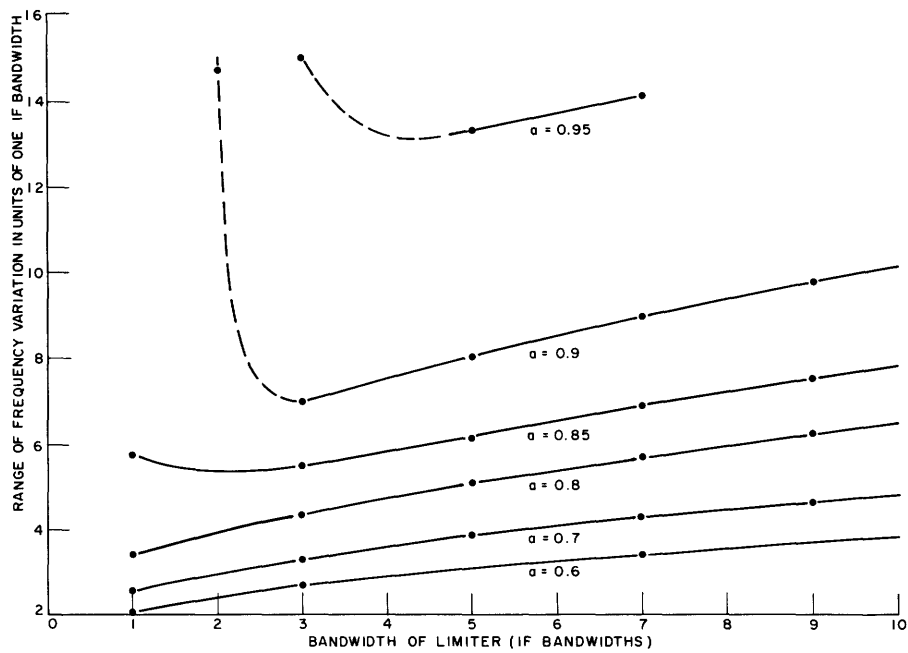

Fig. 9. Possible range of instantaneous-frequency variation at output of single narrow-band limiter as a function of filter bandwidth.

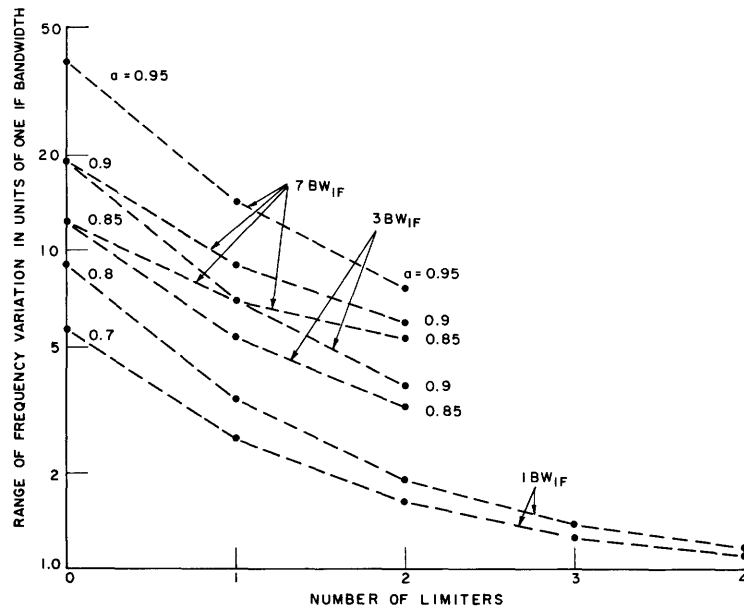

Fig. 10. Possible range of instantaneous-frequency variation at output of cascade of narrow-band limiters as a function of the number of limiter stages.

The same information is presented in another useful way in Fig. 9. The frequency variation at the output of a single limiter-filter stage is plotted as a function of the filter bandwidth, for different fixed values of \underline{a} . This figure reveals the interesting fact that for values of \underline{a} greater than approximately 0.84 there is an optimum filter bandwidth for which the frequency variation is minimum. If the bandwidth is increased or decreased, the frequency variations become more severe. Only for interference ratios less than 0.84 are the frequency variations least when the filter has the minimum permissible bandwidth of one i-f bandwidth. The same information is also presented in Fig. 10 as a function of the number of limiter-filter stages, for various interference ratios.

Calculations have also been made (2) for the properties stated in cases (a) and (d). But the systems covered by these cases are less efficient in the suppression of interference than those discussed here.

2.3 FREQUENCY-DEMODULATOR SECTION

The function of the demodulator section is to convert, in a linear manner, changes in the frequency of the incoming wave into changes in output voltage. The demodulator should have an output-voltage-versus-input-signal frequency characteristic that is linear over a sufficient range (see Fig. 11), and it should be insensitive to input amplitude variations.

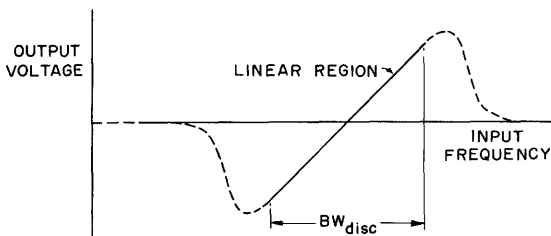

Fig. 11. Discriminator characteristic.

The extent of the amplitude variations at the demodulator input can be determined from Fig. 5. When the variations are removed by means of an amplitude limiter, the limiter designer may be guided by Fig. 5.

The peak-to-peak variation of the instantaneous frequency at the output of a chain of narrow-band limiters has been plotted in Figs. 6-10. This variation must be faithfully converted into output-voltage fluctuations whose mean deviation from the voltage level dictated by p is zero. In this way, the disturbance will be completely filterable if r exceeds the lowpass filter bandwidth. Thus the demodulator transfer characteristic must have a linear range at least as great as the bandwidth obtained from the appropriate figure (Figs. 6-10).

Because of the fast changes in the waveform that is to be demodulated, special precautions must be taken to ensure that the demodulator will follow it. When the demodulator is a conventional balanced discriminator, the peak-detector discharge time constants must be sufficiently short that the amplitude fluctuations at the output of the tuned circuits will be followed faithfully. It has been shown (2) that the time constant of each peak detector must satisfy the inequality

$$T \leq T_{\max} = \left| \frac{e(t)}{e'(t)} \right|_{\min} \quad (7)$$

where $e(t)$ is the envelope of the signal that is to be demodulated (the instantaneous-frequency time function at the output of the limiter section).

When the filters in the limiter section have arbitrary bandwidths, it is difficult to compute $e(t)$ in order to compute T_{\max} . Therefore, the computation has been carried out only for the simplest case, in which all filters have a bandwidth equal to the i-f bandwidth. In this case, the spectrum at the output of each filter has only two components, at the frequencies of the weaker and stronger signals (in the most serious situation, when $r = BW_{if}$). The interference ratio (the ratio of weaker to stronger component) at the output of any filter for a given interference ratio at the input of that filter is plotted in Fig. 12.

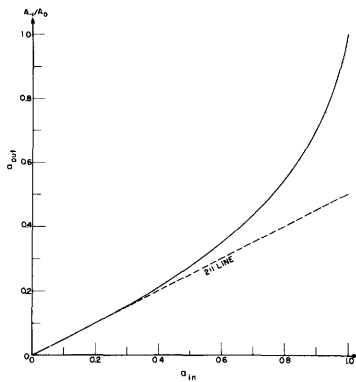

Fig. 12. Interference ratio a_{in} at input, and interference ratio a_{out} at output, of a narrow-band limiter stage, when the filter bandwidth is equal to one i-f bandwidth.

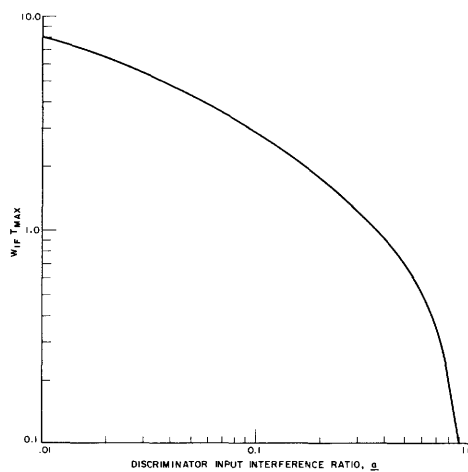

Fig. 13. Maximum permissible value T_{\max} versus balanced-discriminator time constant.

By using this figure as many times as there are stages of narrow-band limiting, the interference ratio \underline{a} at the discriminator input can be calculated. With the definitions

$$\beta(a) = \frac{1 + a}{5(1-a)(a(1-a^2))^{1/2} W(a)} \quad (8)$$

$$W(a) = \frac{\{2[(1+a^2)(1+34a^2+a^4)^{1/2} - (1+10a^2+a^4)]\}^{1/4}}{\sqrt{a}[3(1+a^2) - (1+34a^2+a^4)]} \quad (9)$$

it can be shown that

$$r \left| \frac{e(t)}{e'(t)} \right| = \left[\frac{1 + B \cos rt}{C + D \cos rt} + \frac{C + D \cos rt}{1 + B \cos rt} \right] \frac{(1 + B \cos rt)^2}{AB \sin rt} \quad (10)$$

where

$$A = \frac{\beta(1-a)^2}{(1+a^2)}, \quad B = \frac{2a}{1+a^2}, \quad C = 1.225 - A, \quad D = 1.225 B$$

The minimum value of Eq. 10 is best computed numerically for $a > 0.01$. For $a < 0.01$, the minimum value occurs very nearly at $rt = \pi/2$, and we may use the approximate expression:

$$r \left| \frac{e(t)}{e'(t)} \right|_{\min} = \left[(1.225 - A) + \frac{1}{(1.225 - A)} \right] \frac{1}{AB} \quad (11)$$

where

$$A = \frac{1 - \frac{9}{2}a^2}{5\sqrt{a}}, \quad B = 2a(1-a^2)$$

An extended plot of $T_{\max} \cdot W_{if}$, where $W_{if} = r/2\pi$, is shown in Fig. 13.

2.4 OUTPUT LOWPASS-FILTER SECTION

The voltage at the demodulator output is delivered to an amplifier and lowpass filter that provides the proper frequency response characteristic to compensate for the pre-emphasis of the message in the transmitter. There are no special requirements for this section when the receiver is to be used in the presence of interference. The amplifier and filter should each have only the usual property of being linear.

In the presence of interference, the voltage delivered to the input of this section will have fluctuations at the frequency-difference rate about the desired average value. During most of the time, the frequency difference r will be larger than the cutoff frequency of the lowpass filter (2.12 kc), and the fluctuations will be filtered out. During the small portion of the time when $r/2\pi < 2.12$ kc, the fluctuations will pass to the

receiver output and cause a degradation of the desired message. But when this happens, the fluctuations are necessarily smallest; thus the effect of the interference will not be serious.

2.5 INTEGRATED DESIGN OF THE RECEIVER

We have shown that the presence of interference at the input of an FM receiver imposes some special requirements upon the different sections of the receiver. It is evident that the largest interference ratio that can be handled by the receiver (the "capture ratio") will be determined by whichever of these requirements is violated first as the interference is made more severe. For example, as a is increased toward the value at which loss of the desired average frequency would occur in some limiter filter, both the required signal at the next limiter input and the required width of the demodulator frequency characteristic become infinitely large, and the greatest permissible discriminator time constant becomes zero. These conditions, of course, are quite severe. The largest value of the capture ratio that can be attained in a receiver with a given number of stages of narrow-band limiting may be determined by any one of these requirements, or by some combination of them.

If maximum capture performance is desired from each limiter stage, the gain-bandwidth product for each stage must be considered. Suppose that we desire to keep the minimum output signal from the first narrow-band limiter stage as large as possible because the limiting threshold of the second limiter is critical. Clearly, there is an optimum value for the bandwidth of the filter following the first limiter tube; for, as the filter bandwidth is reduced, the amplitude fluctuations become more severe, whereas if the bandwidth is increased, the decreasing gain will surely cause the signal to drop below the threshold. The amplitude minimum of the signal at the output of the first limiter-filter stage is a function of the bandwidth of the filter and the interference ratio a . As we progress down the limiter chain to the output of the n^{th} stage, the amplitude minimum becomes a function of all n filter bandwidths, as well as of the interference ratio. Of course, the gain-bandwidth problem can be eliminated by introducing the necessary filters in separate amplifiers between the various limiter units.

Another interesting relationship is apparent from referring to Fig. 9, which shows that (for $a = 0.863$) there is an optimum value of limiter-filter bandwidth for minimizing the frequency excursions at the output of a narrow-band limiter stage.

Since there is one optimum set of filter bandwidths for minimizing the amplitude excursions, and another optimum set of bandwidths for minimizing the frequency excursions, a criterion for optimum design of a receiver might be that the limiter thresholds, discriminator bandwidth, and time constants become unacceptable, simultaneously, as the interference ratio is increased. As a practical matter, however, it appears that it is more difficult to obtain adequate limiting thresholds and gain-bandwidth products to ensure sufficient limiter input amplitudes when the filter is a part of the limiter circuit.

III. RAPID-ACTING LIMITERS WITH GATED-BEAM PENTODES

3.1 INTRODUCTION

At the present time, three different types of amplitude limiter are commonly used in FM receivers. They may be described as follows:

(a) In the pentode limiter, grid-leak self-bias causes the plate current to flow in short pulses whose energy is independent of the input signal amplitude (above a certain threshold). Filtering out all frequency components except the fundamental yields a sinusoid of constant amplitude.

(b) In the diode limiter, a pair of biased diodes are used to severely clip both top and bottom of the input wave. All frequency components except the fundamental of the resulting square wave are filtered out and, provided that there is no interaction between clippers and the associated filter, a sinusoid of constant amplitude is obtained.

(c) In the gated-beam pentode (3, 4) limiter, the input waveform is clipped on one side by cutoff, and on the other side by the abrupt saturation of the tube, to obtain a square wave. Filtering out of all frequency components except the fundamental yields a sinusoid of constant amplitude.

Although the pentode limiter is the most common type used in existing equipment, it has the disadvantage that the RC grid-leak self-biasing circuit is often unable to follow the fast changes in amplitude that are caused by interference. After an impulsive disturbance charges the grid-leak capacitor, the tube is cut off for a time. The resulting interruption in reception accentuates the degradation caused by the interference. Since the diode clipper and gated-beam pentode operate with fixed bias and do not depend upon low-frequency time constants, they do not exhibit this disadvantage. However, for each stage of limiting, the diode clipper requires two diodes and one stage of amplification, whereas the gated-beam pentode alone achieves the same result. Moreover, the interaction between the gated-beam pentode and its associated filter is much less

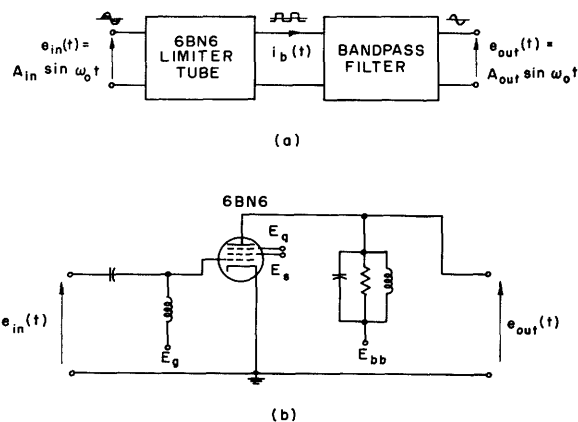

Fig. 14. Gated-beam pentode limiter: (a) block diagram; (b) circuit diagram.

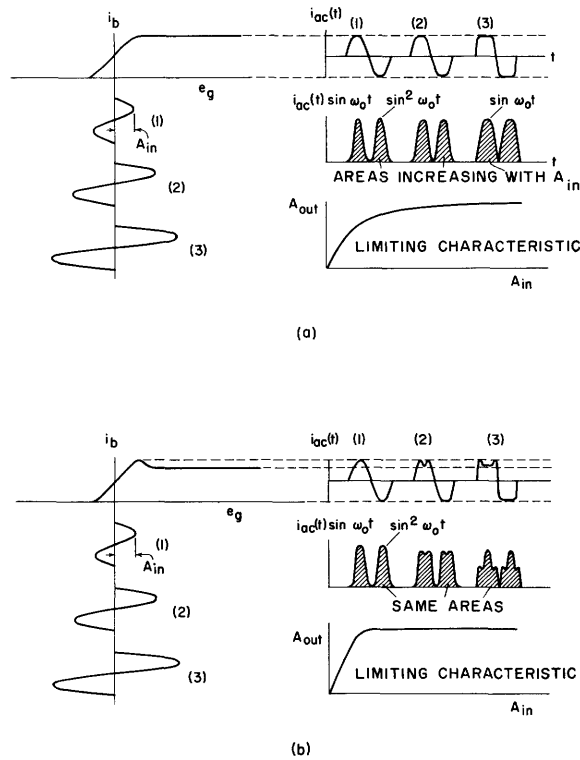

Fig. 15. Comparison of limiting characteristics. (a) Effect of flat transfer characteristic. (b) Effect of transfer characteristic with overshoot.

noticeable than is the interaction between the diode clippers and their filter. Thus, of these three types, the gated-beam limiter is potentially the most attractive. We present a condensed report of the results of a detailed investigation of the properties of the gated-beam pentode, for the purpose of determining its suitability as an amplitude limiter.

A functional block diagram and a simplified circuit of the gated-beam pentode limiter are shown in Fig. 14. When a sinusoid of amplitude A_{in} is applied to the input, the abrupt cutoff and saturation of the tube causes the plate current to be almost a square wave, with an amplitude that is determined by the cutoff and saturation levels of the tube and is independent of A_{in} . Thus the output of the narrow bandpass filter is, again, a sinusoid of amplitude A_{out} that is nearly independent of A_{in} . The limiter is characterized by its "limiting characteristic," the plot of A_{out} against A_{in} . The limiting characteristic should be flat above the "limiting threshold" at which the limiting action begins.

It is helpful to note that in order to obtain the flattest limiter characteristic above the limiting threshold, the transfer characteristic of the tube should exhibit a slight overshoot at the beginning of the saturation region. This fact is substantiated graphically in Fig. 15. Such an overshoot can be obtained with most tubes by proper adjustment of the electrode potentials.

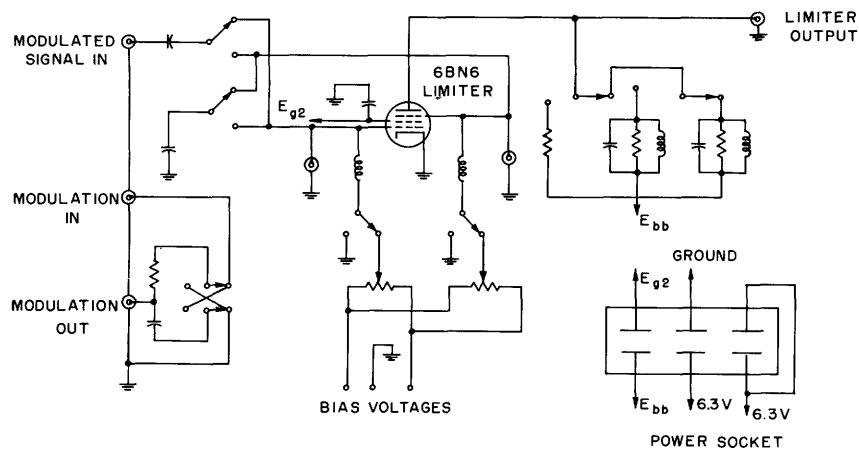

Fig. 16. Schematic diagram of 6BN6 dynamic limiter-characteristic plotter.

In order to determine the acceptability of the gated-beam pentode for use as an amplitude limiter, extensive measurements were made on 50 different 6BN6 tubes, one-half of which came from each of two manufacturers. A dynamic limiter-characteristic plotter enabled the display of the limiting and transfer characteristics of a tube on an oscilloscope when an amplitude-modulated sinusoid was applied to the plotter input. Provision was made for varying all electrode potentials, and filters of different impedance levels could be inserted in the plate circuit of the pentode. The circuit diagram is shown in Fig. 16. With the aid of the plotter, the following properties were investigated for all of the 50 tubes:

- (a) The shape of the transfer characteristic that yields the best limiting characteristic.
- (b) The quality of the best obtainable limiting characteristic when all electrode potentials are appropriately adjusted.
- (c) The values of control-grid and quadrature-grid biases that will result in the best limiting characteristic when different plate and screen voltages are applied.
- (d) The values of plate and screen voltages that will result in the best limiting characteristic.
- (e) The sensitivity of the shape of the limiting characteristic to deviations from the correct values of bias, plate, and screen voltages.
- (f) The effect of changing the plate-load impedance upon the shape of the limiting characteristic and upon the optimum values of the biases.
- (g) The amplitude of the fundamental component of the plate current.
- (h) The input signal amplitude that is necessary for reaching the limiting threshold.
- (i) The characteristics of tubes of different manufacturers.

In addition to these tests, measurements by Price (5) of the effective average input circuit loading caused by grid current as the tube is driven into saturation were modified

to make them applicable when the tube electrode voltages are adjusted to the most desirable values.

3.2 SUMMARY OF RESULTS

The detailed procedure by which this investigation was carried out, and the exact measurements that were made, are described in the author's thesis (6). Only a summary of the results obtained for a sample of 50 tubes is presented here.

First, we found that with the best possible adjustment of the electrode potentials only approximately one tube in ten had an "excellent" limiting characteristic, four tubes in ten had a "good" characteristic, and the rest had "fair" or "poor" characteristics. The meaning of these ratings is approximately defined by the oscillograms in Fig. 17. "Excellent" or "good" characteristics are flat within approximately 10 per cent, or less.

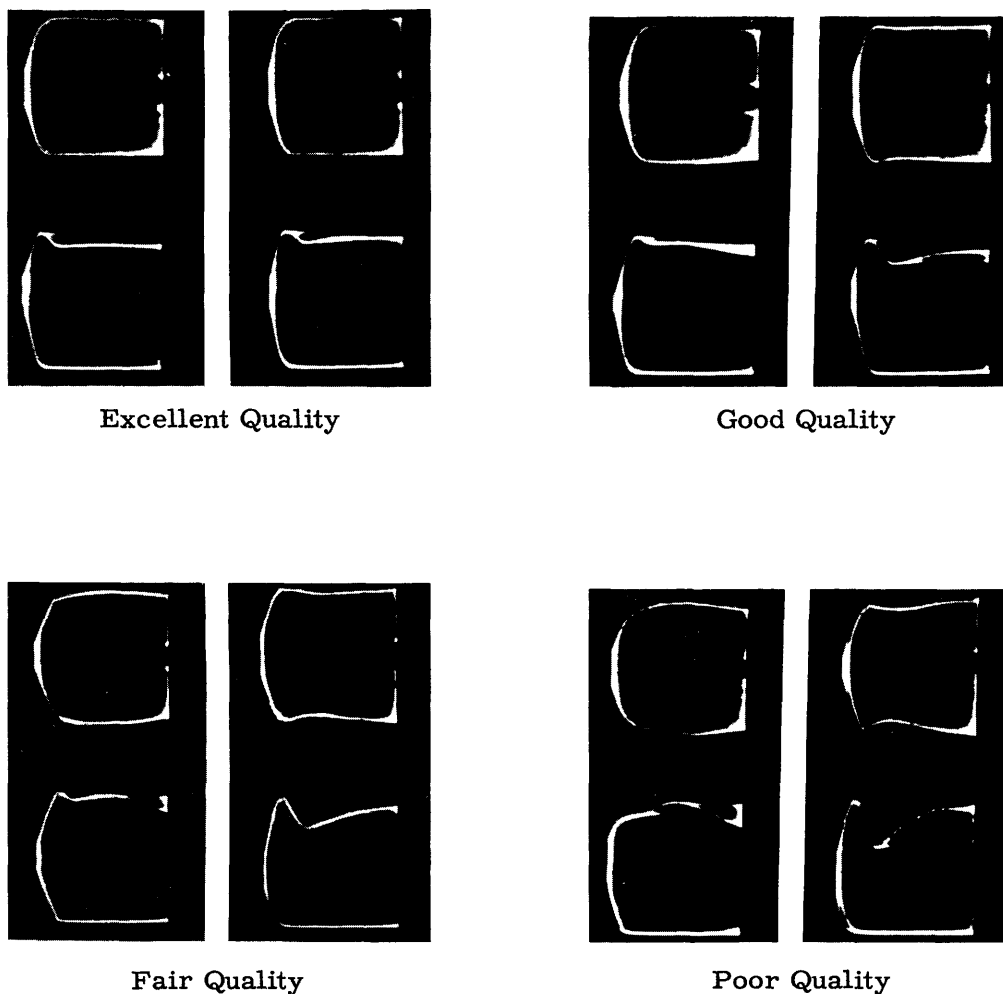

Fig. 17. Limiter (top, in each picture) and transfer (bottom, in each picture) characteristics of 6BN6 gated-beam limiter tube.

Note the overshoot at the beginning of the saturation region of the transfer characteristics in the picture marked "excellent."

The tubes tested were very sensitive to the adjustment of supply voltages, and the values necessary for satisfactory operation differed widely from tube to tube. It was necessary to provide for individual adjustment of the bias voltages for each tube, and a large variation was found in the output plate current. The necessary value of quadrature grid bias was found to vary appreciably with the size of the plate-load impedance.

Finally, the nonlinear input circuit loading caused by grid current was found to be particularly severe, so that it was necessary to supply the grid input signal from a low-impedance source.

To aid the circuit designer, some useful numerical data from the tests just described are summarized in the appendix.

3.3 USE OF THE GATED-BEAM PENTODE AS A NARROW-BAND LIMITER

If gated-beam pentodes are to be used in a chain of narrow-band limiters, close attention must be paid to the problem of obtaining sufficient output from each stage to use as input for the succeeding stage. Reference to the appendix will show that under normal operating conditions the effective average input resistance of a tube may be as small as 25 K. Since the tube acts as a highly nonlinear load on the source from which the input signal is obtained, it is desirable that the tube be driven from a source that has an internal impedance that is approximately an order of magnitude lower (or 2.5 K). The mean value of the plate-current fundamental component, I_{po} , is approximately 0.9 ma peak-to-peak, and the mean value of the limiting-threshold voltage, A_t , is approximately 3 volts peak-to-peak. Hence, if two gated-beam pentodes are coupled by placing a narrow-band filter with an impedance level of 2.5 K in the plate circuit of the first stage, only approximately 2.3 volts peak-to-peak will be delivered to the input of the second stage, and this is below the limiting threshold of the second stage!

The situation may be improved considerably by using coupling networks between the stages that provide a more efficient impedance match between the output of one stage and the input of the next. If two stages are coupled with a critically coupled double-tuned circuit that reflects a 2.5 K grid-circuit impedance into the preceding plate circuit at a level of 50 K, a grid voltage of approximately 12 volts (nearly four times the threshold voltage) will be obtained. (It has been shown (7) that the magnitude of the transfer impedance of an inductively coupled double-tuned circuit is approximately one-half the geometric mean of the input and output impedances.)

If we refer to Fig. 5, we find that when the narrow-band filter has a bandwidth equal to the i-f bandwidth, the amplitude fluctuations in the presence of interference will cause the signal at the second-limiter input to drop below the limiting threshold for interference ratios greater than 0.76. Statistical variation among tubes, and supply-voltage fluctuations can make the situation even worse, although improvement can be achieved

by using a wider filter bandwidth. It appears that the gated-beam pentode operates only marginally as a narrow-band limiter if no interlimiter coupling amplifiers are used.

IV. ILLUSTRATIVE DESIGN AND PERFORMANCE OF A LABORATORY RECEIVER

We shall now briefly describe a laboratory receiver designed according to the information contained in Sections II and III. Our main purpose has been to determine how well the performance of the receiver can be predicted if the design procedure is carefully followed. There are at least two good reasons for subjecting the theoretical design procedure to experimental test. First, the theory forming the basis for the calculations described in Section II assumes the use of ideal (flat-amplitude, linear-phase) bandpass filters in the limiter section. The effect of using practical filters must be investigated. Second, the rate at which receiver performance is degraded as various design criteria are violated is not known. Because of the complexity of calculating these effects, the information is most easily obtained by direct experimental measurement.

The laboratory receiver consists of four sections: a 10.7-mc i-f amplifier section, a narrow-band limiter section, a balanced-discriminator frequency demodulator section, and an audio amplifier and lowpass filter section. The circuit diagram of the receiver is shown in Fig. 18.

The i-f amplifier consists of three 6AU6 stages coupled with double-tuned circuits. The pole locations of the double-tuned circuits are adjusted so as to obtain a sixth-order Butterworth over-all frequency characteristic for the amplifier. As a result, it is possible to ensure that the frequency characteristic is flat (within 1 per cent, or less) within the amplifier passband. Alignment of the amplifier is facilitated by the use of photographic masks showing the proper shape of the frequency characteristic of each stage. The over-all frequency response characteristic obtained is shown in Fig. 19.

The limiter section has three limiter-filter stages. Each stage consists of a 6BN6 gated-beam pentode with a critically coupled, double-tuned coupling network and bandpass filter as plate load. The double-tuned circuits were designed to present as high an impedance as possible (subject to gain-bandwidth limitations) to the plate of the preceding 6BN6 tube and a 2.5 K impedance to the input of the following 6BN6 tube, in order to obtain the greatest possible gain without causing nonlinear loading. The tubes have been selected to obtain the largest possible gain with acceptable limiting characteristics. The limiting characteristic and frequency-response characteristic of each stage are shown in Fig. 19. The normalized input voltage ratio and filter bandwidth are given in Table I.

The frequency demodulator consists of a 6BN6 limiter followed by a conventional balanced discriminator. The demodulator limiting characteristic and frequency characteristic are shown in Fig. 19.

The last section of the receiver consists of an amplifier and cathode follower, preceding a standard RC de-emphasis network with a half-power frequency of 2.12 kc.

The capture performance of the receiver is clearly brought out by a plot of the amplitude of a detected single tone used to modulate a test signal in the presence of a weaker

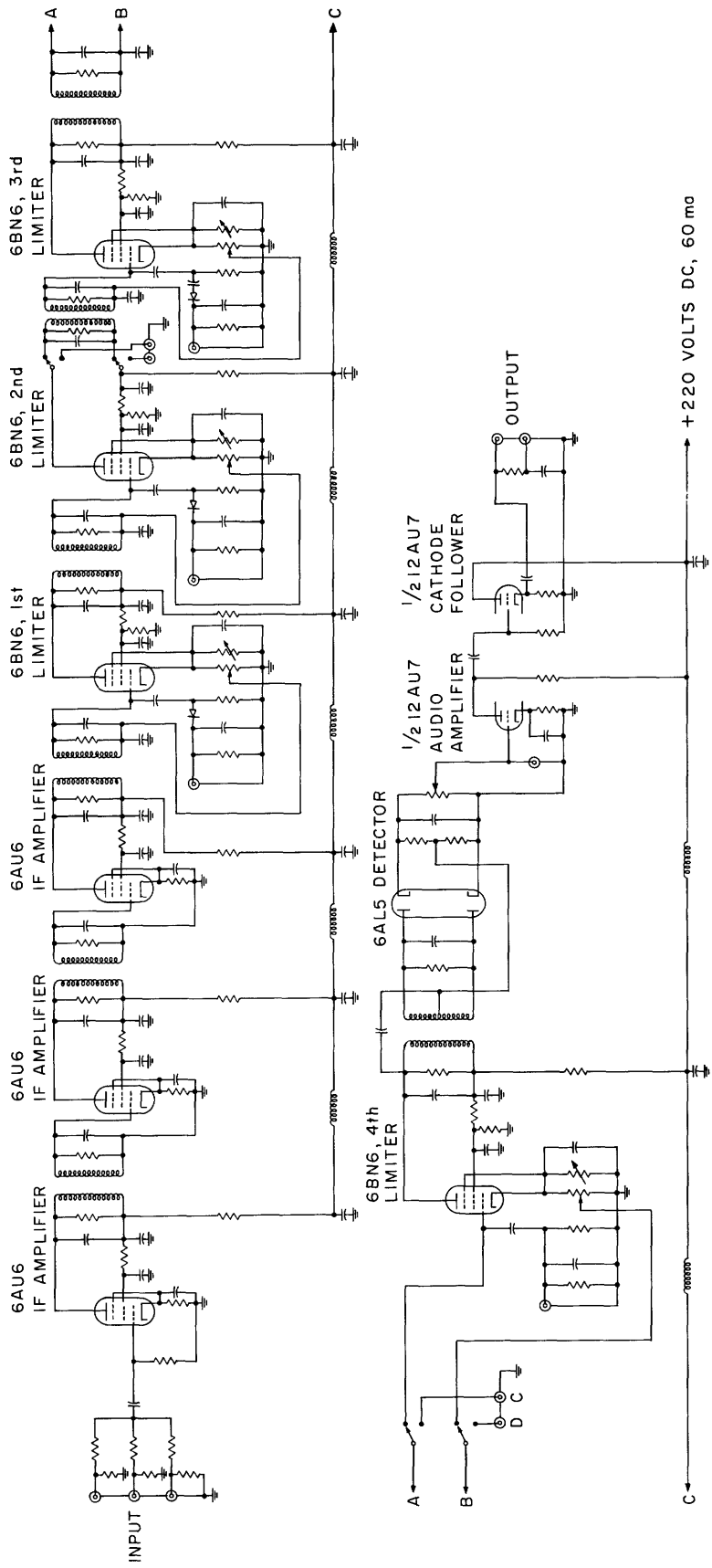

Fig. 18. Schematic diagram of the receiver.

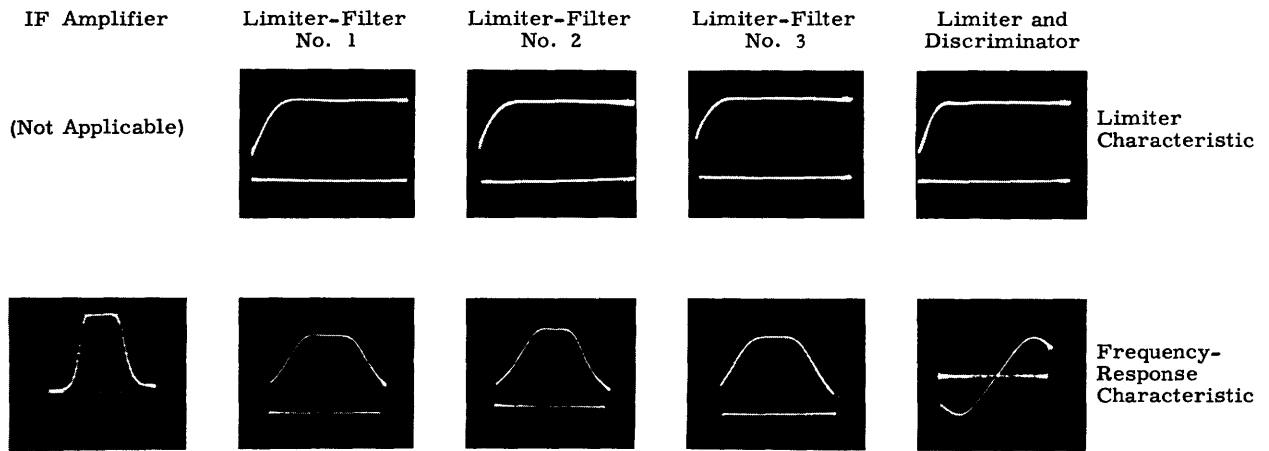

Fig. 19. Characteristics of i-f amplifier, limiter-filter, and limiter-discriminator stages of experimental FM receiver.

Table I.

Receiver Section	Normalized Input Voltage Ratio	Bandwidth Between 95 per cent Points	Bandwidth Between Half-Power Points
Limiter No. 1	4.48	400 kc	560 kc
Limiter No. 2	3.28	140 kc	250 kc
Limiter No. 3	3.02	170 kc	310 kc
Limiter No. 4 and Discriminator	2.60	linear range: 300 kc	

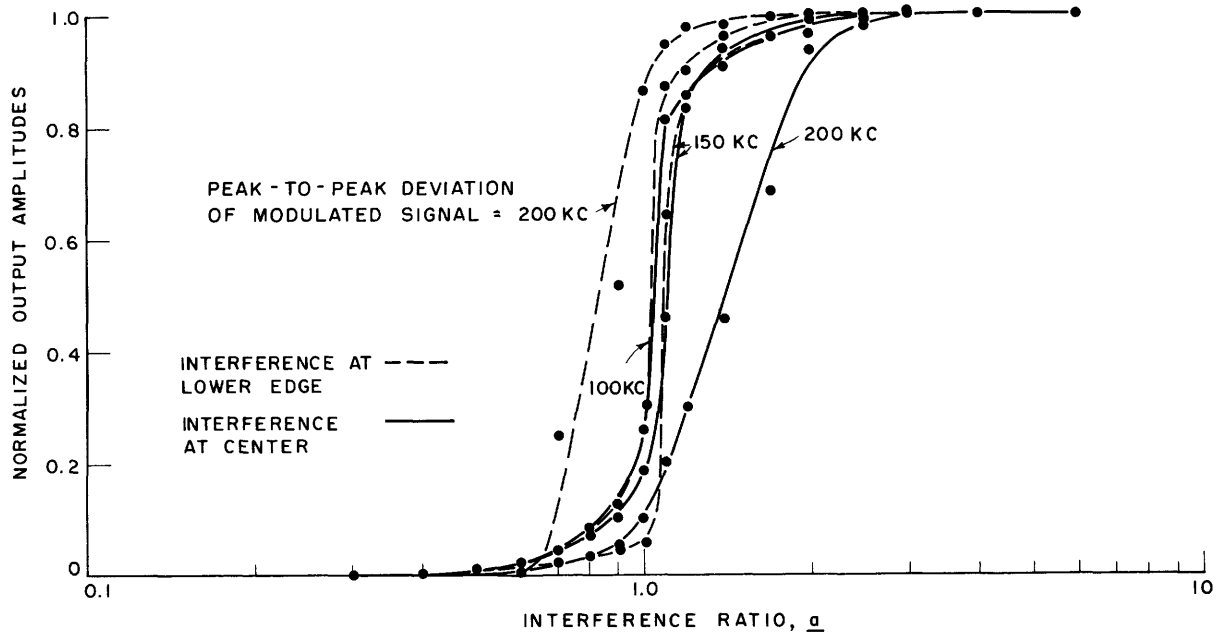

Fig. 20. Capture characteristics.

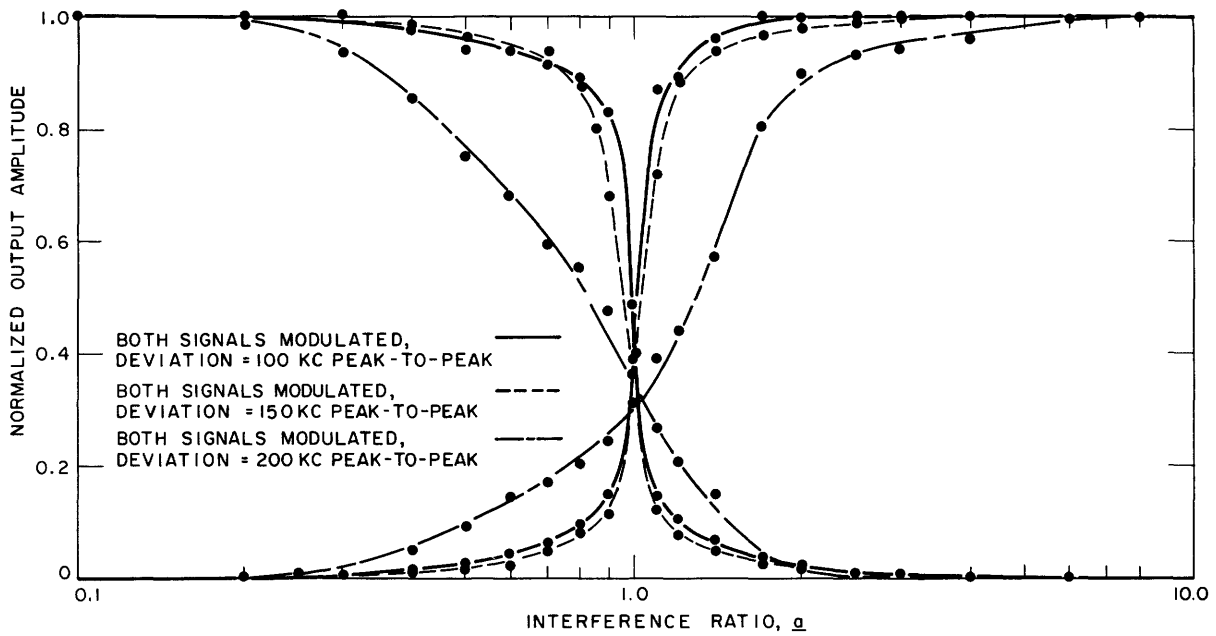

Fig. 21. Capture characteristics.

signal as a function of the interference ratio \underline{a} . Such a plot is called the receiver "capture characteristic." Various types of distortion of the sinusoid may also be measured as a function of \underline{a} .

Two kinds of test were performed on the receiver. First, capture characteristics were obtained for different frequency locations of a weaker unmodulated signal relative to a modulated stronger signal. The results are shown in Fig. 20. Second, capture characteristics were measured with each signal modulated sinusoidally by a different tone, with three choices of equal peak-to-peak frequency deviation. These curves are shown in Fig. 21.

V. COMPARISON OF THEORETICAL AND EXPERIMENTAL PERFORMANCE

In order to compute the theoretical maximum value a_{\max} of the interference ratio for which the receiver will operate satisfactorily, it is necessary to know the normalized limiter input amplitude ratio, the normalized limiter-filter bandwidths (in units of the peak-to-peak frequency deviation of the input signals, usually taken as the i-f bandwidth), the normalized discriminator bandwidth, and the normalized discriminator time constants. This information, normalized for the peak-to-peak frequency deviations used in the tests, is presented in Table II. By applying these data to Figs. 5-10, the estimates listed in Table III of the theoretical value of a_{\max} for each section of the receiver are obtained. Since it would be expected that the receiver would fail to reject interference when its poorest section fails, inspection of Table III shows that the theoretical capture ratio (maximum interference ratio) for the receiver should be $a_{\max} = 0.70$ for a peak-to-peak deviation of 150 kc, and $a_{\max} = 0.76$ for a peak-to-peak deviation of 100 kc, both limits being set by the limiting threshold of the limiter No. 4.

The capture characteristic of Fig. 21 (the only one that is certain to include the most adverse interference situation) does not show any abrupt drop in the vicinity of $a = 0.70$. In fact, when the frequency deviation is 150 kc, interference first becomes apparent in the receiver output for much smaller ratios ($\sim a=0.4$), and rises to an amplitude of 0.07 units (a signal-to-interference ratio of approximately 28 db) by the time a has reached the value $a = 0.70$. However, this is a reasonable shape for the capture characteristic because the application of modulated signals (rather than the unmodulated carriers assumed in the theory) to the receiver input causes receiver operation to differ from the theory in two important respects: (a) the capture characteristic displays receiver operation averaged over a variety of frequency differences r , most of which cause instantaneous-frequency disturbances less serious than those for the worst value of r used in theoretical calculations, and (b) the capture characteristic includes the effect of the instantaneous-frequency disturbances that pass through the lowpass filter to the receiver output when the frequency difference r is audible. The capture characteristic qualitatively confirms the theoretical calculation, for the critical value $a = 0.70$ is just slightly below the sharp knee of the curve.

It turns out to be a relatively simple matter to investigate analytically, for a few simple cases, the effect of one of the assumptions underlying the theoretical calculations. It is not difficult to repeat some of the calculations with a slightly less idealized model for the bandpass filters: the assumption of a flat amplitude characteristic inside the passband and infinite attenuation outside the passband has been replaced by the more reasonable assumption of a second-order Butterworth amplitude characteristic (but the assumption of linear phase has been retained). Calculations of the normalized second-limiter input amplitude ratio and output instantaneous-frequency fluctuation have been made for an interference ratio $a = 0.9$; they are presented as a function of the filter half-power bandwidth in Figs. 22 and 23. The curves for the

Table II.

Receiver Section	Normalized Limiter Input Amplitude Ratio	Normalized Filter Bandwidth	
		Deviation 150 kc p-p	Deviation 100 kc p-p
Limiter No. 1	4.48	3.67	5.50
Limiter No. 2	3.28	1.55	2.33
Limiter No. 3	3.02	1.53	2.30
Limiter No. 4 and Discriminator	2.60	2.00	3.00
Normalized Discriminator Time Constants $T \cdot W_{if}$		2.25	1.50

Table III.

Receiver Section	Maximum Interference Ratio a_{max}	
	Signal Deviation 150 kc p-p	Signal Deviation 100 kc p-p
Limiter No. 1	0.78	0.78
Limiter No. 2	0.91	0.94
Limiter No. 3	0.74 [*]	0.80 [*]
Limiter No. 4	0.70 [*]	0.76 [*]
Discriminator Bandwidth	0.85	0.90
Discriminator Time Constants	0.75 [†]	0.92 [†]

^{*}Because of lack of information about the reduction of amplitude variations by many stages of narrow-band limiting, these figures are for operation as second limiter; therefore they are too small.

[†]Because of lack of information about the time constant requirements with filter bandwidths greater than one i-f bandwidth, all filters are assumed to have one i-f bandwidth; therefore these figures are too large.

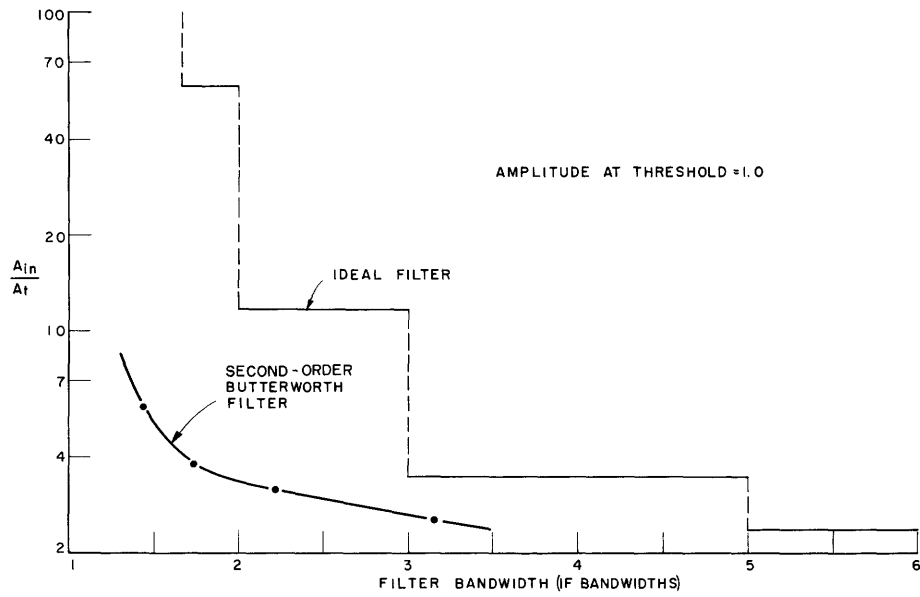

Fig. 22. Amplitude ratio A_{in}/A_t required at second-limiter input with idealized second-order Butterworth filter ($a=0.9$).

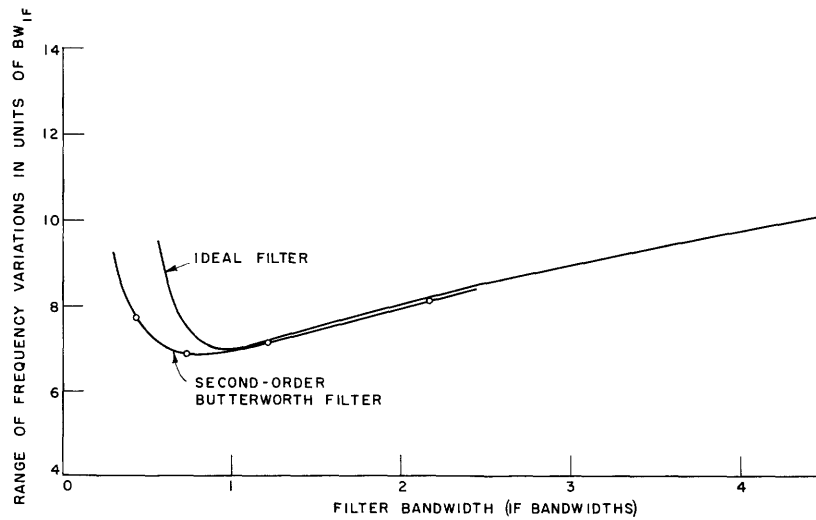

Fig. 23. Possible range of instantaneous-frequency variation at output of idealized second-order Butterworth limiter filter ($a=0.9$).

ideal filter are included for comparison.

The most striking fact revealed by the computations is the very close agreement between the instantaneous-frequency variation of the ideal and Butterworth filters. This would lead us to believe that the more extensive curves for the frequency variation at the output of ideal filters could be used dependably in receiver design. Also, it may be seen that the use of the Butterworth filter appears to ease the receiver design requirements: the critical value of the interference ratio becomes higher with Butterworth filters (at least, according to these two design criteria). Unless the effect of a realizable filter phase characteristic is serious, the idealized model appears to give results of sufficient accuracy for receiver design.

APPENDIX

NUMERICAL DATA FOR OPERATION OF GATED-BEAM LIMITERS

The data presented here are based upon tests described in the author's thesis (6). They are results of measurements taken on fifty 6BN6 gated-beam pentodes.

It is recommended that tubes be operated with a plate voltage $E_{bb} = 100$ or 150 volts, a screen voltage $E_s = 50$ volts, and a 1 K plate-load impedance. In extreme cases, however, the limiting characteristic may be improved, as shown in Fig. 24a, by adjusting E_s to a different value. Also, when limiters are cascaded, a more efficient impedance match between stages may be obtained with little loss in quality of the limiting characteristic by using a plate-load impedance of 50 K (see Fig. 24b).

Mean values and expected deviations of the necessary bias voltages, the output plate currents, and the limiting threshold voltages for the 50 tubes are shown in Table IV.

Table IV.

	MEAN VALUE FOR 50 TUBES				STANDARD DEVIATION	
	Load Impedance = 1 K		Load Impedance = 50 K		(per cent)	
	$E_{bb} = 100$ v	$E_{bb} = 150$ v	$E_{bb} = 100$ v	$E_{bb} = 150$ v	$E_{bb} = 100$ v	$E_{bb} = 150$ v
Control Grid Bias E_g (volts)	1.89	1.89	1.83	1.80	10.6	10.6
Quadrature Grid Bias E_q (volts)	2.51	3.69	2.05	3.17	13.6	11.4
Plate Current Fundamental Component I_{po} (ma peak-to-peak)	0.82	0.90	0.82	0.87	31.7	34.4
Input Amplitude at Limiting Threshold A_t (volts peak-to-peak)	2.95	2.95	2.95	2.95	9.8	9.8

Oscillograms of the effects upon the limiting characteristic of bias and supply voltage changes are shown in Fig. 24c. Estimates of the changes permitted without causing I_{po} or A_t to vary more than approximately 10 per cent are shown in Table V.

A plot of the effective average input resistance of the tube is presented as a function

Table V.

Operating Voltage	Necessary Stability
E_{bb}	4% (to control I_{po})
E_s	9% (to control I_{po})
E_g	20% (to control A_t)
E_q	4% (to control I_{po})

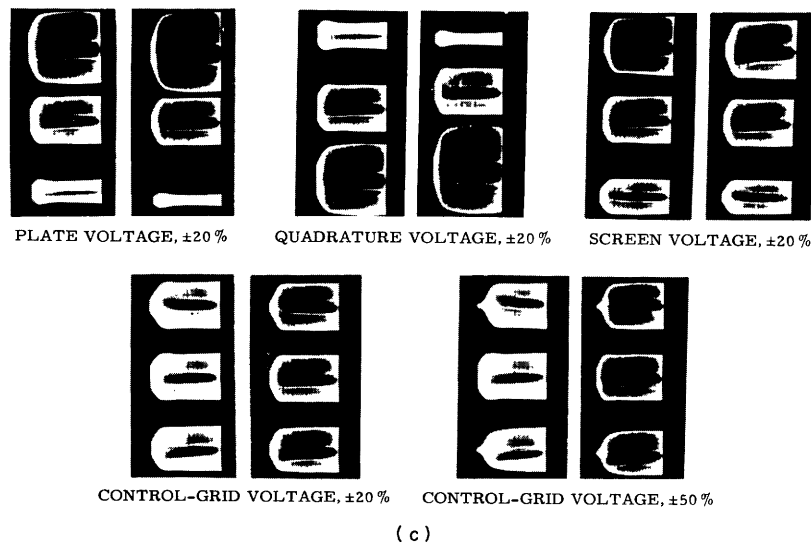
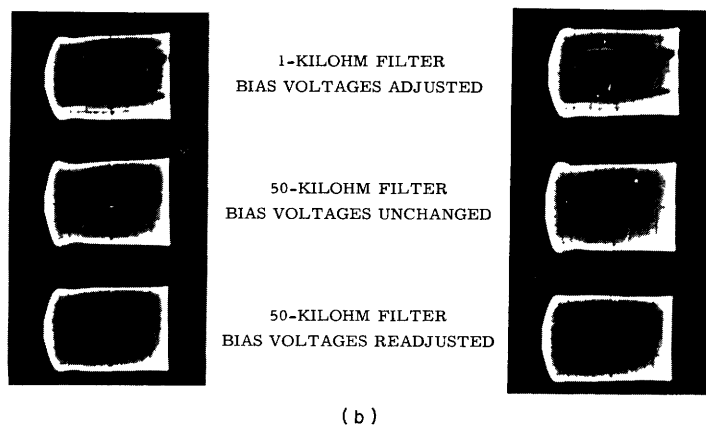
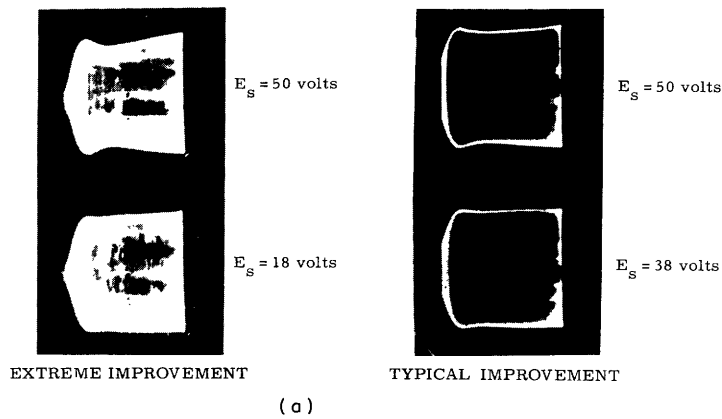

Fig. 24. (a) Limiter-characteristic improvement resulting from change of screen voltage from the value $E_s = 50$ volts. (b) Effect of different load impedances upon limiter characteristic of 6BN6. (c) Sensitivity of 6BN6 limiter characteristic to incorrect adjustment of supply and bias voltages.

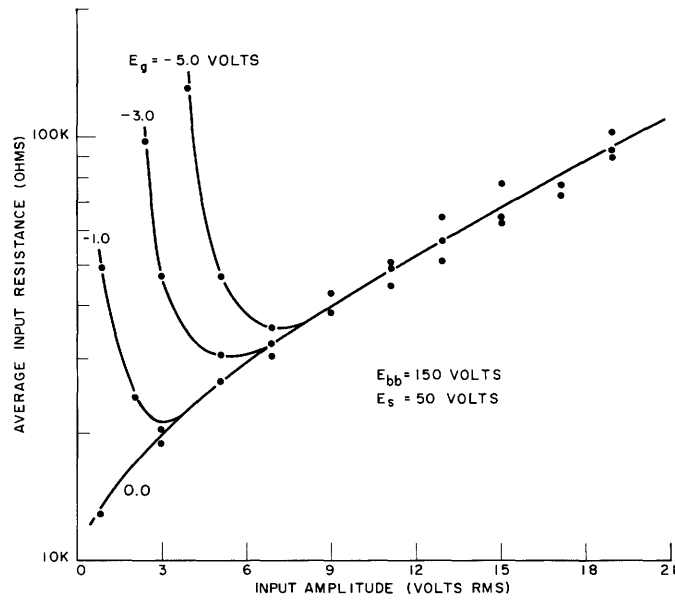

Fig. 25. Average input resistance of 6BN6 gated-beam limiter tube.

of the rms input signal in Fig. 25, for various values of control grid bias E_g . The resistance is approximately independent of the quadrature grid bias E_q .

Acknowledgment

The author takes pleasure in acknowledging the stimulation and guidance of Professor Elie J. Baghdady during the course of this research, and is especially grateful for the generous contribution of his time in many helpful discussions. He also wishes to thank him for permission to use one of the figures from Technical Report 252 as Fig. 12 of the present report.

The author is also greatly indebted to his fellow-student George J. Rubissow for many suggestions that have contributed intangibly to this report.

References

1. E. J. Baghdady, Frequency-modulation interference rejection with narrow-band limiters, Proc. IRE 43, 51-61 (1955).
2. E. J. Baghdady, Interference Rejection in FM Receivers, Technical Report 252, Research Laboratory of Electronics, M. I. T., Sept. 24, 1956.
3. R. Adler, The 6BN6 gated beam tube Part 1, Proc. National Electronics Conference, Vol. 5, pp. 408-416, 1949.
4. A. P. Haase, The 6BN6 gated-beam tube Part 2, Proc. National Electronics Conference, Vol. 5, pp. 417-429, 1949.
5. R. A. Price, A Study of the Gated-Beam Limiter, S. M. Thesis, Department of Electrical Engineering, M. I. T., June 1953.
6. R. J. McLaughlin, A Study of FM Capture Effects, S. M. Thesis, Department of Electrical Engineering, M. I. T., June 1958.
7. R. J. McLaughlin, Design and adjustment of bandpass amplifiers, Quarterly Progress Report, Research Laboratory of Electronics, M. I. T., Oct. 15, 1957, pp. 56-62.

