

# Landmine Removal: Technology Review and Design Proposal as Pertaining to Humanitarian Demining with a Focus on Locomotion across Soft Terrain

by

Amanda N. Poteet

SUBMITTED TO THE DEPARTMENT OF MECHANICAL ENGINEERING IN PARTIAL FULFILLMENT OF THE REQUIREMENTS FOR THE DEGREE OF

BACHELOR OF SCIENCE IN MECHANICAL ENGINEERING  
AT THE  
MASSACHUSETTS INSTITUTE OF TECHNOLOGY

JUNE 2008

©2008 Amanda N. Poteet. All rights reserved.

The author hereby grants to MIT permission to reproduce and to distribute publicly paper and electronic copies of this thesis document in whole or part in any medium now known or hereafter created.

Signature of Author: \_\_\_\_\_  
Department of Mechanical Engineering  
May 9, 2008

Certified by: \_\_\_\_\_  
Thrishantha Nanayakkara  
Thesis Supervisor

Accepted by: \_\_\_\_\_  
John H. Lienhard V  
Professor of Mechanical Engineering  
ME Undergraduate Officer

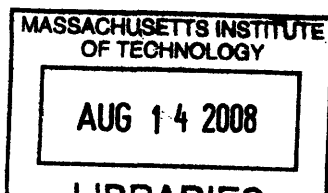

ARCHIVES



LANDMINE REMOVAL: TECHNOLOGY REVIEW AND DESIGN PROPOSAL AS  
PERTAINING TO HUMANITARIAN DEMINING WITH A FOCUS ON LOCOMOTION  
ACROSS SOFT TERRAIN

By

AMANDA N. POTEET

Submitted to the Department of Mechanical Engineering  
on May 9, 2008 in partial fulfillment of the  
requirements for the Degree of Master of Science in  
Mechanical Engineering

ABSTRACT

A study into the field of humanitarian landmine removal was conducted; with significant attention devoted to an in depth review of existing removal technologies, as well as alternative detection methods.

A design proposal was also presented in addition to the technology review. The design is for an autonomous robot which is capable of working in conjunction with canine demining units, with further implications for the development of a robotic unit capable of landmine detection.

Further investigation was done into the possible modes of robotic locomotion, resulting in the determination that mechanical legs, as opposed to wheels, are the better choice when traversing across soft terrain.

Thesis Supervisor: Thrishantha Nanayakkara

## Table of Contents

List of Figures.....	5
Chapter 1:Introduction.....	1-15
1.1 Motivation.....	6-8
1.1.1 Human Costs .....	6-7
1.1.2 Economic Costs.....	7-8
1.2 Background .....	8-15
1.2.1 History of Use .....	9
1.2.2 Landmine Overview .....	10-14
1.2.3.Terrain .....	14-15
Chapter 2: Review of Existing Removal Technologies .....	15-30
2.1 Demining Categories .....	15-16
2.2 Manual Deming .....	16-18
2.3 Mechanical Removal Methods .....	18-23
2.3.1 Cultivators .....	18-19
2.3.2 Mine Blades .....	19-20
2.3.3. Flails .....	20-21
2.3.4 Earth Tillers .....	21-23
2.4 Alternative Methods for Landmine Removal .....	23-30
2.4.1 Electromagnetic Detection Methods .....	23-26
2.4.2 Acoustic/Seismic Detection Methods .....	26-27
2.4.3 Chemical Methods .....	27-28
2.4.4 Biological Methods .....	28-30
Chapter 3: Design for Demining .....	30-41
3.1 Sensing Unit .....	31-35
3.1.1 Outer Shell .....	32-33
3.1.2 Sensors .....	33-35
3.2 Locomotion .....	35-41
3.2.1 Locomotion Methods .....	35
3.2.2. The Benefit of Mechanical Legs .....	35-41
3.2.3. Further Applications .....	41
Bibliography .....	42

## List of Figures

1: Cut Away of US Made M16 Fragmentation Mine .....	11
2: US Made M14 Anti-Personnel Landmine .....	12
3: PFM-1 Anti-Personnel Landmine .....	13
4: Minefield Terrains .....	15
5: Manual Landmine Removal.....	17
6: Landmine Removal Using Flail .....	20
7: Counter-rotating Drums of Demining Earth Tiller .....	22
8: Canine Demining .....	30
9: Sketch of Sensing Unit .....	31
10: Sketch of Dispenser Doors .....	32
11: Leg Modeled as Mass-Rod Pendulum .....	36
12: Collision Between Leg and Soft Ground .....	38

# Chapter 1: Introduction

## 1.1 Motivation

The primary focus of this work is the discussion of landmines, as well as the technology being developed to remove them from lingering minefields. However, before we begin, it is important to understand the motivation behind demining efforts. After all, with all the other problems with the world, why should landmines be a priority? This section aims to address this question, looking at it from both social and economical perspectives.

### 1.1.1 Human Costs

Landmines are unique amongst modern day munitions in that they kill indiscriminately. There is no way to differentiate between victims; a mine cannot distinguish the footstep of a soldier from that of a child. In essence, a landmine is a self contained, autonomous weapon with a single goal: to maim or kill whoever is unlucky enough to trigger it. Unfortunately, the majority of the time this unlucky person is a civilian. Depending on the source, it is estimated that there are approximately 10-20 thousand landmine related casualties per year worldwide,<sup>1</sup> occurring in over 75 nations (Landmine Monitor Group 2007). In the year 2006, it was estimated that approximately 75 percent of these casualties involved civilians. 59 percent of these incidents involved children under the age of 15. Military personnel accounted for 24 percent of the total

---

<sup>1</sup> Two points: First, it is important to note that both injuries and deaths are considered to be casualties, as the distinction is often left unmade when incident totals are reported. Second, the higher end of the estimated casualty totals takes into account the fact that many incidents occur in rural regions with little to no medical assistance, thus many incidents may go unreported.

casualties.<sup>2</sup> Professional deminers represented the fewest number of casualties, accounting for only 1 percent of the total incidents. (Landmine Monitor Group 2007)

If we assume that the estimate of 10-20 thousand annual incidents is correct, then we can reasonably estimate the cumulative number of landmine related casualties to be somewhere between 600,000 and 1.2 million.<sup>3</sup> For perspective, this number is like filling 15 professional football stadiums with people who were injured or killed by taking one wrong step. The Department of Defense estimates that approximately 100,000 incident have involved American casualties<sup>4</sup>; this number would fill approximately 1.5 stadiums.

### **1.1.2 Economic Costs**

Loss of life is not the only consequence of landmine incidents; there are also significant economic costs as well. For victims fortunate enough to survive, this cost is often in the form of expensive medical bills. Apart from the initial care, it can cost anywhere from 100-3000 dollars to outfit a landmine survivor with a necessary prosthetic limb. In addition, adult prosthetics must be replaced every two to three years; more frequent replacement is required for child victims (Adopt-a-Minefield n.d.). Apart from medical expenses, victims often suffer from their inability to return to work. Lost income not only affects victims, but their families as well.

The economic cost of landmines is not limited to individuals. The economy of an entire region can be hurt due to the fact that minefields often occupy parcels of land which could be utilized, in many cases for agriculture. However, because of the danger involved with lingering

---

<sup>2</sup> The country of Columbia represents an overwhelming number of these military casualties. If Columbia is removed from consideration, military casualties drop to approximately 12 percent of the total number. From Landmine Monitor report

<sup>3</sup> Estimate based on the fact that landmines have been used heavily for approximately 60 years (since WWII)

<sup>4</sup> As a side note, it is estimated that 33 percent of the US deaths during the Vietnam War were due to landmines, as were 26 percent of US deaths in Somalia and approximately 13 percent of US deaths in the First Gulf War. (Landmine Survivors Network n.d.)

minefields (in the form of risk to both human life and the lives of valuable livestock), this land goes unused and undeveloped. In many affected areas, agriculture is the primary industry. Loss of land due to minefields directly relates to a loss of potential profits for the region. In many cases, this loss of potential profits further attenuates the poverty of a region, not only by taking away monetary funds, but also by increasing the homeless population.<sup>5</sup>

Lastly, affected countries are not the only ones to feel the economic effects of landmines and their necessary removal. Because the cost of removal is so high<sup>6</sup>, it falls on more affluent nations to lend a hand<sup>7</sup>. Billions of dollars are spent each year in the demining effort. The US alone spends approximately 100 million dollars per year in demining related aid (Landmine Monitor Group 2007), with many other nations contributing comparable amounts to the cause of landmine removal.

## **1.2 Background**

Thus far we have only described the costs associated with the presence of lingering minefields. However we feel that it is important to have an understanding of the history of landmine use, as well as a basic understanding of landmines themselves (the latter of these two subjects being of greater importance to our later discussion of landmine removal technology). The following section presents an overview of these topics.

### **1.2.1 History of Use**

---

<sup>5</sup> During most conflicts there exist a number of civilians who become refugees. The presence of minefields makes it difficult for these displaced persons to return home, often leaving them with no place to go.

<sup>6</sup> It costs approximately 1000 USD to remove a single landmine. The cost of manufacturing the same mine can be as little as 3 USD (Landmine Monitor Group 2007)

<sup>7</sup> It is important to note that many of these affluent nations, such as the US and Russia, are responsible for many of the lingering minefields. This is not to imply however that they are responsible for all of the minefields which exist today.



The modern landmine was developed during World War One. Initially a response to the introduction of battle tanks the first landmines were a defensive tool aimed at disabling or destroying advancing enemy vehicles. While reasonably effective, these mines were often rather large and relatively easy to remove. This meant that not only could the enemy detect a mine; he could then remove it and use it for his own purposes. Anti-Personnel mines were introduced to combat such theft. These mines were much smaller than anti-tank mines; their function being to wound or kill an enemy soldier instead of damaging a piece of machinery.

Although landmines were introduced in World War One, it was not until World War Two that their use became widespread, especially on the Eastern Front and in North Africa. (International Committee of the Red Cross 1996) By the end of the Second World War, a precedent was set and landmines became a tool common to almost every modern conflict. As previously mentioned, landmines were originally deployed in a defensive manner. However, as conflicts began to shift more towards guerilla-style warfare, the use of landmines became more offensive. No longer limited to stopping advancing infantry, landmines were employed to cut off an enemy retreat, as well as to deprive an enemy of access to essential resources such as water or shelter. This kind of offensive use has continued into today, although it is not limited to conflicts between formal governments. Revolutionaries as well as terrorist groups commonly employ the use of landmines within civil conflicts, often to the detriment of many civilians.

## **1.2.2 Landmine Overview**

### *Anti-Tank Landmines*

There are two main categories of landmine: anti-tank and anti-personnel. Anti-tank mines are often fairly large in size, often nearing a foot in diameter. Because vehicles are the primary targets of such mines, the pressure required to trigger them is higher than that for anti-personnel mines.<sup>8</sup> For this reason, the majority of demining efforts are focused on anti-personnel mines, which pose a more direct threat due to the lower pressure threshold required for detonation. However, it is important to remove anti-tank mines as well as they pose a significant threat to vehicles and farm equipment.<sup>9</sup>

### *Anti-Personnel Landmines*

There are two main categories of anti-personnel landmines: fragmentation mines and blast mines. Incidents involving fragmentation mines often tend to result in a greater number of fatalities. This is due to the fact that upon detonation, fragmentation mines expel metal shards at very high velocities. It is these shards which are intended to cause damage, as opposed to the explosion itself. These mines often have a larger kill radius, (many meters), as the metal pieces may be flung quite a distance. Characteristic injuries include damage to the upper body, especially if the victim is within close proximity of the blast. (Strada 1996) Figure 1 below shows a common type of fragmentation mine, the US made M16 landmine:

---

<sup>8</sup> For many anti-tank landmines the required pressure is upwards of that exerted by a mass of 100 kg. In other words, it would take an object weighing 220 pounds or more to cause detonation.

<sup>9</sup> Again, we are not implying that anti-tank mines are unimportant. However, most technology which can detect and remove an anti-personnel mine can also be used for the removal of the larger mines. The same is not true for all technology aimed solely at anti-tank mines.

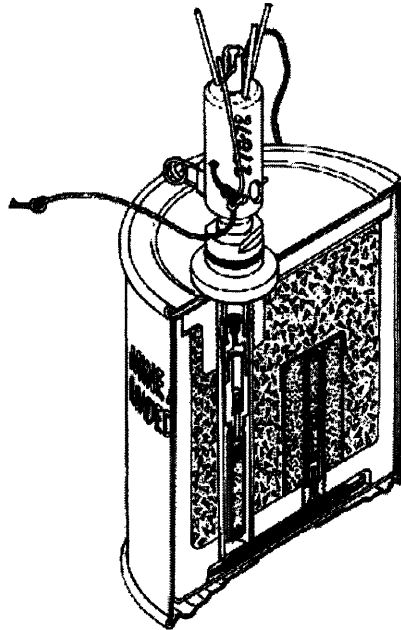
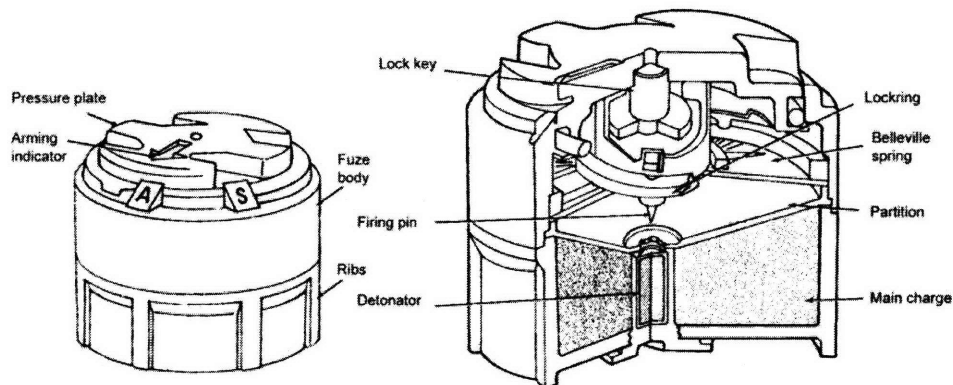

**Figure 1: Cut away of US-made M16 fragmentation mine**  
Photo courtesy of US Department of Defense

The M16 is an example of what is referred to as a “bounding mine”. These mines use a propelling charge to raise the mine to approximately waste height before explosion, thus ensuring that maximum damage is done once the metal shards are expelled. The M16 contains approximately 521g (1.15 lbs) of TNT explosive. When the mine is triggered (either by applying pressure or by pulling the spring-loaded release pin), the pin is removed from the fuse, enabling the ignition of the percussion cap. The percussion cap then fires a delay element in the fuse, which in turn fires a detonator after a short delay. The propelling charge is then detonated, after which the main charge explodes, releasing metal fragments. (Bonsor 2001)

The metal fragments released by fragmentation mines can either come from shards stored within the mine, or from a segmented outer casing (as with the M16) which breaks apart upon detonation. Although the damage done by these mines is often more extensive, the metal components makes these mines easier to detect. In fact, unlike with blast mines, conventional metal detectors can often be employed fairly successfully.

The other category of anti-personnel landmine is known as a blast mine. These mines rely on the force of the explosion alone to inflict damage. They are often triggered by a pressure plate, with a threshold of only 5 kg before detonation (this means that something weighing little more than 10 lbs may trigger the explosion). These mines were not necessarily intended to kill the victim, their primary goal being to wound.<sup>10</sup> Common injuries resulting from incidents with blast mines include the amputation of one or both legs, as well as the occasional damage to the abdomen and upper body due to secondary particles.<sup>11</sup> Two examples of blast landmines will be discussed below. Figure 2 shows the first of these mines, the US-made M14 anti-personnel landmine:



**Figure 2: US-Made M14 Anti-Personnel Landmine**

Photo courtesy of US Department of Defense

The M14 landmine is very small, approximately 40 mm tall and only 56 mm in diameter. The mine is triggered using a pressure plate, with a threshold of approximately 9kg. This plate pushes on a Belleville spring, which in turn lowers the firing pin. When the pressure threshold is

<sup>10</sup> This stems from the military strategy in which by wounding a soldier, it takes more soldiers to care for him than it would to deal with a dead body. Also, by coming back for a wounded soldier, other troops put themselves at greater risk of triggering another mine.

<sup>11</sup> Bone or other debris such as clothing articles can be blown from the amputated limb during the initial blast at high enough velocities as to act as shrapnel. (From the medical source)

crossed, the firing pin makes contact with the detonator, igniting the main charge of Tetryl explosive (approximately 31g of explosive is used).

The M14 landmine was first introduced by the United States in the 1950's. Although this type of mine is no longer actively deployed by the US military, many other nations around the world have adopted the use of the M14, or of similar technology. Because of their widespread use, these types of mines are very common in lingering minefields. Detection of these mines is difficult, for often the firing pin is the only metal component.

Another common blast mine design is shown in figure 3 below. This mine is known as the Russian-made PFM-1 anti-personnel landmine, although it is more commonly referred to as either the "butterfly mine" or the "green parrot."

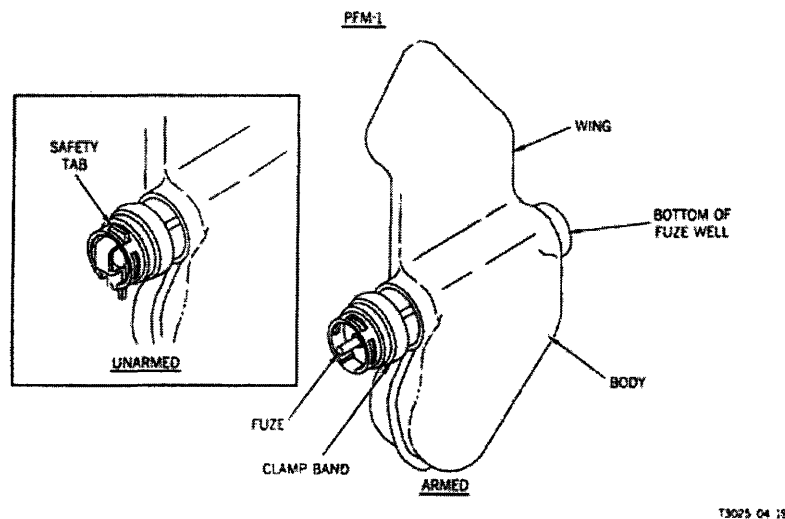

**Figure 3: PFM-1 Anti-Personnel Landmine**  
Photo courtesy of US Department of Defense

Unlike the M14 anti-personnel mine, the PFM-1 is essentially a plastic bag encasing explosive liquid. Deformation of the soft plastic skin forces an arming plunger to strike the detonator. The body of the mine acts as a single, cumulative pressure primer. This makes the

mine extremely dangerous to handle, as a single press of 5 kg or more (or alternatively multiple presses adding up to 5kg) will bring about detonation.

The PFM-1 landmine was designed to be deployed from the air. Its unique shape is what earned it the nickname “butterfly mine.” These mines are often painted in bright colors, such as green (hence the second nickname of “green parrot”). While the bright colors can make detection somewhat easier,<sup>12</sup> they also make these landmines more attractive to children, who mistake these deadly weapons for toys. In Afghanistan, which has the greatest concentration of PFM-1 landmines, an overwhelming number of landmine victims are children. Because these mines can be handled before detonation, injuries sustained in landmine related incidents often involve the amputation of one or more hands, as well as extensive damage to the upper body (Strada 1996). Injuries to children are often fatal due to the mine’s proximity to the face upon detonation.

### **1.2.3 Terrain**

Just as there are many different types of mines to take into consideration, there are a variety of terrains occupied by minefields. These types of terrain range from the sandy deserts and rocky outcroppings in Northern Africa to the tropical and marsh-like locations in Southeast Asia. Each type of terrain presents a different challenge to the demining process. For example, dense vegetation in places such as South America can make detection and removal very difficult. Sand filled environments pose a different challenge as mines are constantly shifted and reburied due to the wind. Damp environments make it difficult to move heavy equipment, if the

---

<sup>12</sup> Detection of the PFM-1 mine is still relatively difficult when the mine becomes buried under soil due to wind, etc. This is because, like the M14, the PFM-1 landmine contains very few metal components, making the use of metal detectors inefficient.

minefields can even be accessed at all. Figure 4 below shows examples of some areas where minefields exist:



**Figure 4: Minefield Terrains – Dense Vegetation, Swamp, and Desert (from left to right).**  
Photo Courtesy of US Department of Defense Humanitarian R&D Program

## Chapter 2: Review of Existing Removal Technologies

For as long as there have been landmines, there has been incentive to remove them. The goal of this chapter is to introduce the concept of military vs. humanitarian demining, as well as to review existing technologies which aim to meet the needs of each.

### 2.1 Demining Categories

There are two distinct categories of demining efforts: military and humanitarian. While the goal of both categories is ultimately the same (the removal of landmines), the two vary greatly with respect to the motivation behind removal. Military demining, for example, is

primarily motivated by the need to traverse across a minefield. The main objective is therefore to create a safe path for vehicles, as well as for any troops which may need to pass through. Only a portion of a field must be cleared in order to achieve the objective of creating a path. Since the goal is to get from point A to point B, little concern is given to the fate of the remaining minefield. Civilians may still be at risk after a military demining effort, as mines are often left in the ground.

In contrast, the aim of humanitarian demining efforts is to remove all landmines within a given area, thus enabling for the utilization of the formerly contaminated land. Only after an area has met the 99.6% removal standard (as set down by the UN) can it be considered safe for civilian occupation. Another important aspect of humanitarian demining has to do with how the mines are dealt with. Unlike in military demining, where destruction of a mine is acceptable, in humanitarian demining all mines must be properly removed and disposed of<sup>13</sup>. This makes the issue of detection that much more important. In addition, as mentioned before, much of the land cleared through humanitarian efforts is intended for agricultural use. For this reason, important considerations must be made in regards to the top soil conditions in these regions. The fertile top soil must be preserved during the demining process, making methods which simply remove the mine-containing dirt layer (such as bulldozing) unpractical for humanitarian demining.

## **2.2 Manual Demining**

Currently the only method capable of reaching the 99.6% removal standard is manual

---

<sup>13</sup> In countries where there is still political unrest or terrorist activity, it is not uncommon for civilians to remove landmines and then sell them on the black market. For this reason, in humanitarian demining mines must be removed and accounted for before they may be destroyed.



demining (see figure 5 below).



**Figure 5: Manual Landmine Removal**  
<http://www.inarooee.ebonet.net/images/homemdesminando.jpg>

Manual demining is not only a time consuming task, it is also extremely labor intensive. Trained deminers must spend hours in the field each day, often in very hot temperatures. Deminers work within a section that is approximately 1 meter wide. Progress is slow moving, as every forward inch must be thoroughly checked before a worker will risk stepping forward.

The biggest challenged faced by manual demining lies within the detection of mines. Current methods include the use of a metal detector and a probe. While metal detectors are relatively good at detecting metal encased landmines, they are not efficient at locating mines which contain mostly plastic. Additionally, the use of metal detectors can result in a large number of false positives. These false positives can be caused by the detection of some other metal source, such as old bullet casings or pieces of shrapnel from a long-passed battle. As every positive must be confirmed to ensure the safety of the worker, false readings are costly both in time and in manual effort.

Despite the relatively low number of casualties among professional deminers, the bottom

line is that manual demining directly endangers human lives<sup>14</sup>. Unfortunately, until effective alternatives can be found, it will continue to be the primary method for humanitarian demining.

## **2.3 Mechanical Landmine Removal Methods**

As mentioned above, there is a great need for alternative methods to manual demining. There exist today a number of such methods, a subsection of which involves the use of mechanical equipment to detect and remove landmines. The hope is to reach an acceptable level of clearance (99.6%) while decreasing the amount of time to do so. Within this section we will discuss four existing methods, focusing on their attributes, limitations, and applicability to humanitarian demining.

### **2.3.1 Cultivators**

Cultivators are a type of landmine removal equipment which can be attached to a bulldozer. They are designed to uncover buried anti-tank mines while maintaining the soil's agricultural capabilities. Cultivators use a series of tines to bring the mines to the surface. In tests, cultivator technology has been able to successfully remove mines to a depth of approximately .2 meters (8 in). This depth can be increased up to .38 meters (15 inches) in areas with loose soil. The uncovered mines are then passed through an auger which in turn casts them to side allowing for easy collection and removal.

Cultivator technology has been tested on a variety of terrains, and appears to be effective even in areas with moderate vegetation.<sup>1</sup> However, there are some serious limitations to consider.

---

<sup>14</sup> Not only of the deminers, but also of any other civilians which may be in the area

For one, small anti-personnel mines may pass straight through the auger and get redistributed into the field. There is also a chance that the mines may detonated while passing through the auger. While the equipment is designed to be resistant to such blasts, repeated occurrence could result in damage over time. In addition, the possibility that mines may detonate adds an extra security risk to people who may be in the vicinity.

Another important consideration to consider is weight. Some existing prototypes which employ the use of cultivator technology (MCC) weigh in upwards of 31 metric tons (US Department of Defense Humanitarian Demining 1998). This makes transportation of the device difficult. The immense weight also means that the cultivator will not be useful in areas with damp terrain, for it will tend to sink into softer ground. This technology is therefore inapplicable to many affected regions, such as those in the wetlands of Southeast Asia.

Despite its limitations, cultivator technology does appear to be a step in the right direction. The effective removal of anti-tank mines is encouraging, although improvements to the technology will need to be made before this can be used as a humanitarian demining tool, the key concern being the capability to remove of anti-personnel mines.

### **2.3.2 Mine Blades**

A mine blade is an array of digging teeth designed to take the place of a standard bulldozer blade. The digging teeth are passed through the soil, pulling up a mixture of dirt and larger objects such as landmines. The collected material is then passed through a series of sifting teeth; the larger objects are sorted out whilst the dirt is returned to the field. As with a cultivator, the sorted landmines are deposited to the side of the bulldozer for later removal.

A unique feature of a mine blade is the ability to preset the depth at which the digging teeth will rake the field. This control allows for a constant clearing depth, ensuring for the most

efficient removal of any landmines.

Unlike other removal methods such as military plows or the use of standard bulldozer blades, mine blades do not require highly trained operators. The use of a mine blade also eliminates the constant adjustments that are required to ensure that conventional removal methods are effective.

Just as a small landmine may pass through the auger of a cultivator, so might one pass through the sifter mechanism in a mine blade. This can result in the return of smaller mines to the path being cleared. Technological advances will need to be made in order to prevent this redistribution of mines before the mine blade can be used as a humanitarian demining tool. Another issue which must also be addressed is the high probability that anti-personnel mines may detonate upon passing through the sifting teeth. While the mine blade is designed to be resistant to mine blasts, repeated explosions could result in damage to the unit. Explosions also pose a risk to nearby persons; in addition to making it unsafe to operate the unit manually (thus remote controlled vehicles become a necessity).

### 2.3.3 Flails

Figure 6 below shows an image of a landmine removal flail<sup>15</sup>:



**Figure 6: Landmine Removal Using Flail**  
Photo courtesy of US Department of Defense

---

<sup>15</sup>While the pictured mini-flail is attached to a tank, flail units can also be used with other vehicles such as armored tractors or bulldozers.

Different from previously discussed technologies, the function of a flail is not to remove landmines, but rather to destroy them in the field. Heavy chains attached to a spinning rotor are used to beat the ground. The force of impact is creates enough ground pressure to trigger most anti-personnel mines. Because a flail causes the detonation of the landmine, it is necessary to use a heavily armored, remote controlled vehicle.

While flails are effective against most anti-personnel landmines,<sup>16</sup> they cannot be used in regions where the presence of anti-tank mines is suspected (the damage inflicted by an anti-tank mine is enough to render a flail unit, along with the coupled vehicle, inoperable). In many instances, a minefield must first be checked manually to ensure the safety of the flail. This dependence on manual checks greatly undercuts the flail's ability to be used as a primary demining tool. Additionally, the motion of the chains may actually fling some landmines into previously cleared regions, thus requiring additional manual checks. For this reason, the use of flails appears to be more applicable to military use, where a single path is all that is needed. However, due to the limitations of the technology, it is clear that there may be better alternatives when it comes to demining in general.

#### **2.3.4 Earth Tillers**

Similar to flails, earth tillers aim to destroy mines rather than remove them. These machines are designed to crush both anti-tank and anti-personnel mines. For this reason, earth

---

<sup>16</sup> Some mines, such as blast-hardened mines and mines with small pressure plates, may fail to detonate even when passed over by a flail demining unit.

tillers are remote controlled units capable of withstanding the blast from anti-tank mines with minimal damage. In many instances mines are brought to the surface instead of being immediately crushed. For this reason, earth tillers used in landmine removal efforts are outfitted with both a top and bottom tilling drums, as shown below. These drums provide a means of crushing, and thus destroying, and remaining landmines.

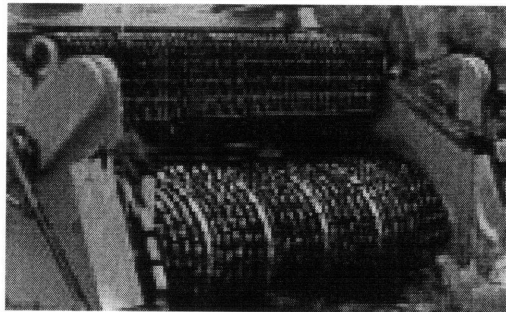

**Figure 7: Counter-rotating drums of demining earth tiller**  
[http://www.eudem.vub.ac.be/organisations/organisation.asp?org\\_id=14](http://www.eudem.vub.ac.be/organisations/organisation.asp?org_id=14)

Although earth tillers appear to provide an effective way to clear a minefield, there are two important considerations to make when assessing their applicability to humanitarian demining. The first of these considerations is common to all of the technologies discussed thus far, in that there is no way to guarantee that all landmines are destroyed. Admittedly the tilling drums of an earth tiller appear to have a tighter tolerance than the auger of a cultivator or the sifter in a mine blade; however there is still the possibility that very small anti-personnel mines, such as the PFM-1 “butterfly mine”, may pass through. The second consideration is the weight of the apparatus. Some existing earth tillers weigh upwards of 56 metric tons (US Department of Defense Humanitarian R&D Program n.d.), making them very inefficient in areas of damp terrain.

Debatably the most promising out of the technologies thus far discussed, earth tillers appear none the less to be the best suited for military applications; they can handle both rocky and overgrown areas (just not muddy ones), and they remove a large variety of both anti-tank

and anti-personnel landmines. However, earth tillers still destroy the mines, which is not in accordance with humanitarian demining protocols.

## **2.4 Alternative Methods for Landmine Removal**

Current research is being done to develop non-mechanical demining technologies. Many of these alternative methods are aimed at detection rather than removal. Right now, the goal is to reduce the risk to manual deminers by determining the location of landmines remotely before any physical demining is undertaken. However, the implication for alternative detection technologies goes much farther. If proven to be reliable methods of detection, these technologies could potentially be used in conjunction with robotic removal equipment, thus removing the need for manual deminers all together.

### **2.4.1 Electromagnetic Detection Methods**

Electromagnetic detection methods utilize the observable differences between the electromagnetic properties of both soil and landmines. They involve the use of electromagnetic waves, introduced into the soil, as a tool for distinguishing landmines from the surrounding ground. In this section, we will discuss three such methods for currently being explored: ground penetrating radar, electrical impedance tomography, and infrared/hyperspectral systems.

#### *Ground Penetrating Radar*

Ground penetrating radar (or GPR as it will henceforth be referred to) is a well-developed technology. However, its use in the application of humanitarian demining is rather new. GPR takes advantage of the fact that different materials have different dielectric constants. During the

detection process, radio waves are emitted into the ground. Wave reflection patterns are then observed (MacDonald, et al. 2003). It is important to note that neither the emission nor the observation processed require contact with the soil. Therefore, the technology may be employed from a distance to ensure the safety of the demining crew. Reflections often happen at locations where there are discontinuities in the dielectric constant, for example the boundary between a landmine and the surrounding soil.

One of the greatest advantages of this technology is that it can be used to detect mines with all types of casings, both metal and plastic (this is due to the fact that both metal and plastic have different dielectric constants than that for soil). However, despite this promising aspect of GPR, there are some limitations. To begin with, the technology can be greatly impacted by soil conditions; the presence of roots or large rocks may lead to false positives. In addition, a high quality image is often necessary to accurately distinguish landmines from other noise which may be observed. This image quality may be increased by increasing the wavelength at which the radio waves are emitted. However, the amount of ground penetration decreases as the wavelength increases, thus GPR is only effective when locating surface mines. Therefore, although GPR appears to be a fairly promising technology, further development is needed before it can be applied to humanitarian applications, which require the removal of buried mines as well.

### *Electric Impedance Tomography*

Electrical Impedance Tomography involves the introduction of an electric current to the soil in order to observe the conductivity profile. As with ground penetrating radar, electric impedance tomography allows for the detection of many different mines, including both those with metal and plastic casings. Unlike GPR however, this electric method involves the placement



of electrodes into the ground, thus requiring human involvement in the field. This involvement means that there is still a chance for worker injury or death.

Another limitation to electric impedance technology is that its effectiveness is highly dependent upon terrain conditions. For example, dry non-conductive soils (such as that which may be found in a desert minefield) render the technology useless. That being said, there may be some very useful applications of the technology with respect to wet terrain. As we have discussed before, wet terrain (such as that found in tropical settings) makes the use of mechanical equipment difficult due to the weight of the machines. Electric impedance technology does not have this issue with weight. Additionally, the water in the environment helps to conduct the electricity introduced, helping, rather than hindering, the detection process.

#### *Infrared/Hyper- spectral Detection*

Infrared/hyper-spectral detection technology uses the observation that landmines (or the soil/vegetation directly above them) tend to either reflect or emit radiation differently than the surrounding soil. These technologies encompass a variety of methods using both active and passive irradiation over a broad range of electromagnetic wavelengths (MacDonald, et al. 2003). Most of these methods fit into two categories: thermal or non-thermal.

Thermal detection methods aim to expand on the observation that the soil/vegetation above a landmine appears to be warmer in temperature during the day, while also having a faster rate of cooling at night (MacDonald, et al. 2003). Laser illumination or high powered microwave radiation can help to induce these observable temperature profiles.

Similar to the difference in temperature associated with a mine is the observation that light (natural or artificial) is reflected differently by the areas surrounding a landmine. Not only do the different materials found in landmines reflect light differently, but the actual process of

laying mines may allow for later detection (the act of burying a landmine can cause the natural particle distribution in the soil to be disrupted, therefore changing the way which the soil scatters light).

Although the use of infrared/hyperspectral technology appears to be an attractive solution to landmine detection (there is no physical contact with the field, can be deployed from aircraft, etc), there are severe limitations which make it unfeasible for practical use. The primary limitation is that the technology is highly sensitive to changes in the environment. The resultant variation in performance levels makes it hard to consider the technology a reliable method in landmine detection. With respect to thermal methods, the wavelength of radiation needed to produce the desired effects corresponds to poor soil penetration. Therefore, many of these methods rely on the observation on naturally occurring thermal radiation. However, the anomalies associated with landmines are easily erased by such things as weathering, thus making the detection of buried mines possible only under limited transient conditions<sup>17</sup>.

#### **2.4.2 Acoustic/Seismic Detection Methods**

Whereas the technologies thus far discussed have all exploited the electromagnetic properties of materials, acoustic/seismic technology takes advantage of the mechanical properties of both the landmine and the surrounding soil. In this case, the exploited property relates to the fact that different materials vibrate differently when exposed to sound waves. Acoustic/seismic mine detection typically involves sound generated from a loudspeaker. While some of the acoustic energy is reflected by the ground surface, a portion of it penetrates the ground in the

---

<sup>17</sup> It is important to note that while the technology is currently not suitable for humanitarian demining on account of the inability to detect buried mines, it has proven to be fairly successful at the detection of surface mines, especially when employed by aircraft.

form of waves which then propagate through the soil. When a wave comes into contact with an object such as a mine, some of the energy is reflected upwards, causing vibrations at the surface level. Sensors can then be used to detect these vibrations without making contact with the ground.<sup>18</sup>

Thus far, acoustic sensing appears to be fairly reliable in that it does not yield many false positives<sup>19</sup> (MacDonald, et al. 2003). The technology also appears to be effective independent of weather and terrain conditions, although some studies indicate that frozen ground may affect sensing capabilities. Mine depth is another aspect capable of having an effect on acoustic/seismic sensing. This is due to the fact that the resonant response (the surface vibrations caused by the reflected acoustic waves) greatly decreases with the depth at which the mine is buried. Therefore, like many of the other alternative technologies discussed thus far, acoustic/seismic sensing is as of yet only applicable to the detection of surface mines. The technology will need to improve if this method is going to be used in humanitarian demining applications.

### **2.4.3 Chemical methods**

Chemical methods are different in that the goal is not to detect the metal or plastic of a landmine's casing, but rather to detect the explosives within. There are two main approaches to chemical sensing: detection of chemical vapors within the air, or detection within the soil. In the latter method, it is sometimes necessary to obtain a soil sample before testing can take place. As this would involve manual collection, this method of chemical testing is not very applicable to

---

<sup>18</sup> Some tested sensors include laser Doppler vibrometers, radars, ultrasonic devices, and microphones. (MacDonald, et al. 2003)

<sup>19</sup> Acoustic/Seismic sensing seems to eliminate many of the false positives associated with rocks and scrap metal; although hollow objects such as soda bottles and cans can give false readings due to the fact that the resonance patterns of these objects are similar to those of landmines. (MacDonald, et al. 2003)

humanitarian demining, at least not as a primary detection method<sup>20</sup>. The other form of chemical testing, however, appears more promising. Through the use of specialized polymers<sup>21</sup>, it is possible to detect trace amounts of chemical vapor in the air (as little as  $10^{-15}$  g explosive material per ml air). This vapor is a product of leaked explosives.

The limitations of chemical detection include the fact that chemical weapons cannot as of yet be deployed on a large scale. Current technology is better suited to work with a manual deminer, with the chemical methods taking place of the traditional metal detector. However, with some advancement of technology, it is not unreasonable to assume that chemical methods, more specifically ones which detect explosive vapors, could be used with robotic removal equipment. Again, the chemical sensors would take the place of more traditional methods of detection.

However, before chemical methods can be employed by either manual or robotic deminers, they need to have a probability of almost 1 relating to mine detection. Because factors such as the environmental conditions or the presence of other explosive remnants greatly affect the effectiveness of chemical methods, it is unlikely that chemical tools will replace existing removal technology (such as the simple demining prod) anytime soon.

#### **2.4.4 Biological Methods**

##### *Fluorescing Organisms*

Just as there are chemical methods designed to detect the presence of explosive vapor in the air (or trace elements of explosives in the soil), so are there biological ones. One subsection

---

<sup>20</sup> There may be a use for this type of chemical testing as a confirmatory method once suspected landmines are marked.

<sup>21</sup> Different types of polymers include for example ones which lose fluorescent capabilities upon the adhesion of explosive molecules, as well as polymers which absorb explosive molecules, thus changing their overall mass in an observable way.

of biological methods involves the use of organisms which fluoresce in the presence of explosives. These organisms are often genetically engineered by inserting a regulatory protein which, upon the recognition of an explosives molecule, will initiate fluorescence (MacDonald, et al. 2003).

This method has been tested in both plants and bacteria. While detection is possible with both organisms, each presents its own problems. For one, plants are not easily distributed throughout a minefield; a person cannot be expected to go into a field to plant the plants, and it takes too long for results to make the distribution of seeds desirable. Bacteria on the other hand are easily distributed. However, the effectiveness of distribution is dependent on soil conditions (dry soil will absorb the bacteria making it impossible to detect them even if they are fluorescing), as well as environmental conditions. In addition, there are strong protests to spraying genetically engineered bacteria over a region which may later be used for agricultural purposes.

### *Detection Using Trained Animals*

Perhaps the most promising and advanced alternative detection technology involves the use of explosion sniffing dogs. The use of dogs has long been employed in mine affected areas due to their ability to locate mines using their heightened sense of smell (dogs are capable of detecting explosive vapors at lower concentrations than any available chemical sensors). By offering a small reward, such as food or play, it is possible to train dogs to signal when they smell a mine (this is usually done by having them sit upon first detection). A manual deminer then follows and investigates the suspect area.



**Figure 8: Canine Demining**  
[www.roncoconsulting.com](http://www.roncoconsulting.com)

While demining dogs are effective, the greatest drawback to using them is the cost; one dog can cost more than 10,000 USD to train (RONCO Consulting Corporation 2008). This high cost (especially for an animal which is at mortal risk each day) is often too high for poorer communities to pay. And even in areas which can afford the animals, results are not one hundred percent guaranteed, as performance is greatly dependent upon the dog and/or trainer. Regardless of these shortcomings however, it is certain that dogs will continue to remain a valuable tool in humanitarian demining.

## Chapter 3: Design for Demining

In the previous chapters, we have attempted to explain the issue of landmine removal (with an emphasis on humanitarian demining), as well as describe various existing removal technologies. In the remainder of this work, we will present and discuss a new design related to humanitarian demining. Our goal is to create a robotic unit which could be used in place of

manual demining. As discussed above, one of the most effective detection methods involves the use of landmine-sniffing animals, predominately dogs. We aim to utilize the natural adeptness observed in these animals by designing a robot which can work in conjunction with them.

Important to note is that this design is still in the concept phase, anything beyond is not within the scope of this paper. However, this work could be used to develop further prototypes which could lead to potential testing of the design within the near future.

### 3.1 Sensing Unit

The design concept is comprised of two main elements, the first of which is a central sensing unit, as a sketched in figure 9 below.

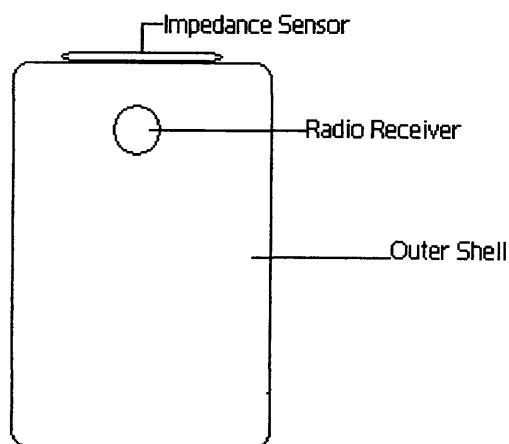

**Figure 9: Sketch of Sensing Unit**

### 3.1.1 Outer Shell

The sensing element is essentially a group of sensors encased in a solid outer shell, which can be made of either metal or hard plastic<sup>22</sup>. The important design constraint for the outer shell (which also pertains to the rest of the robot) is weight; the shell must be large enough to hold the necessary sensors, and yet the entire unit must weigh less than 5 kg (approximately 11 lbs) so as to avoid triggering any of the landmines during the detection process<sup>23</sup>. Along with being lightweight, the outer shell must also be waterproof, as well as weather proof, so as to protect the sensing equipment from the elements.

In addition to being a protective case for the sensors, the outer shell is also designed to act as a small dispensing mechanism. The idea is that when an animal detects a mine, two small doors will open up, dispensing some kind of marking agent. This way, manual deminers will have a clear picture of where the mines are before they ever have to enter the field<sup>24</sup>.

Figure 11 below shows a sketch of the door-dispensing mechanism:

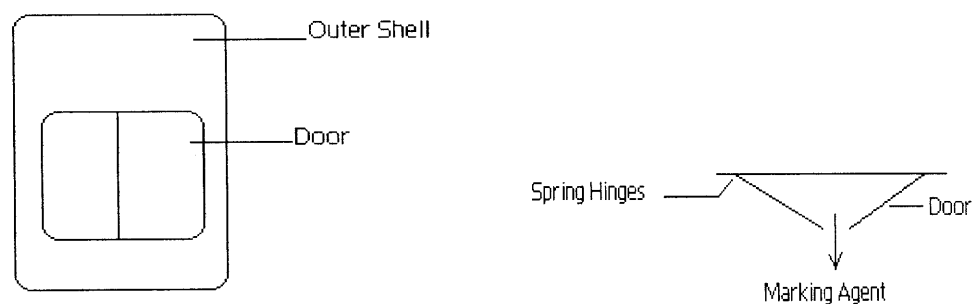

**Figure 10: Sketch of Dispenser Doors (bottom view and side view)**

---

<sup>22</sup>Due to the often harsh conditions in which demining takes place, lightweight metal (such as a coated aluminum) is most likely the best material for the outer shell. However, if such material is not available, hard polymers with a high melting temperature will suffice.

<sup>23</sup>In actuality, it is only the force exerted upon the ground which matters; the machine may weigh more than 5 kg if the weight is distributed so that the force upon the ground at any point of contact is less than that caused by a 5kg mass. However, it is simpler if the entire unit weighs less than 5kg; hence we design in order to meet that condition.

<sup>24</sup>Note that in future iterations, the doors could dispense some form of chemical detection agent, so that the machine could confirm the presence of landmines as opposed to simply marking suspect areas.



In order to save space, the doors must operate in as simple a fashion as possible. That is why we propose the use of two spring-loaded doors. Upon detection of a mine, these doors would open, allowing for the dispersion of the marking agent. The spring action of the doors will return them to the closed position. As for opening the doors, something as simple as a solenoid could be used to apply pressure to the doors, forcing them open, and thus enabling dispersion. Note this design can be modified in future iterations to incorporate the use of alternative detection methods (such as the chemical methods discussed earlier in chapter 2) in addition to the use of marking agents.

Lastly, a subtle yet important design aspect of the outer shell is that it is to have no sharp corners. This is to ensure that the unit does not become tangled in any existing vegetation, and also to ensure the safety of both the human and animal workers involved; we do not want any sharp corners available to cut hands, legs, paws, etc, especially if the outer shell is made of metal.

### **3.1.2 Sensors**

As previously mentioned, a number of sensors will be used. While the eventual goal aims to incorporate detection sensors, the first iterations the majority of sensors will be used for navigation purposes, which will enable the robot to traverse a minefield without running into objects or getting stuck.

During the first stages of development, the unit will be comprised of three primary sensors: a radio receiver, an impedance sensor, and a proximity sensor. The proximity sensor

will be used to determine how close the robot is from objects, rocks and trees for example. This way the robot will know when it is approaching an object so that it can react accordingly.

The main purpose of the impedance sensor is to enable the robot to identify objects as either hard (cannot pass through) or soft (can proceed on course). It is comprised of a spring and a displacement sensor attached to the front of the machine. When the robot makes contact with an object, the spring will compress. The amount of compression is related to the stiffness of the object in the path (the more compression, the harder the object). If the spring compresses beyond a certain threshold, then the robot will know that it cannot push through whatever object is in its path. It will subsequently find an alternative route<sup>25</sup>.

The last main component is the radio receiver. The idea is to have this receiver interact with a radio transmitter located on the collar of the working animal. The robot could then track the motion of the animal during the demining process. When the animal stops (as demining animals are trained to do upon detection of a mine), the robot would be able to detect the lack of motion. It would then move to the signal, and dispense the marking substance near the animal. This would allow the animal and robot to mark the entire field without any human interaction. Once the minefield is marked, manual deminers will be able to go directly to the marked areas and remove the landmines<sup>26</sup>.

As the technology progresses, so will the function of the robot. Initially a marking tool, by the final iteration, the intention is for the robot to be able to detect landmines entirely on its

---

<sup>25</sup> It is important to note that we have been referring to the robot "knowing", etc. This is because the robot will be made to be completely autonomous. The benefit of this is that no special training will be required to operate the unit, making it more accessible across the globe.

<sup>26</sup> Admittedly, there are many possible issues with this method of demining. For one, the animals usually work on a leash. Taking them off of the leash, it could not be guaranteed that they would clear in the straight path so distinctive to manual demining. In addition, animals may develop bad habits if they discover that simply by stopping they are rewarded as treat (the robot will be designed to dispense some small reward). Modifications in dog training may help to alleviate these problems.

own. This will not be possible however, until alternative methods for detecting landmines are improved so as to provide the same level of performance attained using trained animals.

## **3.2 Locomotion**

The remainder of this work has to do with the design for locomotion. After all, the sensing unit will be of little use if the robot cannot traverse a minefield. We will look at two methods of locomotion, and discuss why one may be more efficient than the other for the application of humanitarian demining.

### **3.2.1 Locomotion Methods**

There are two main methods available for the application of robot locomotion; the use of wheels or the use of mechanical legs. While wheels present a well developed, straightforward method for locomotion (after all, the wheel has been around for hundreds of years), we argue that it is not the best method for our purpose of humanitarian demining. Instead, we will look at the use of mechanical legs as a means of moving the robot.

### **3.2.2 The Benefit of Mechanical Legs**

The most apparent benefit of using mechanical legs instead of wheels lies in the ability to traverse multiple types of terrain, especially areas of soft ground. Whereas the motion of a wheel

will actually hinder its own motion over soft terrain (as shown in figure \*\*\* below), by using legs, we can take advantage of the spring-like properties of the ground. As the leg impacts the ground, some of the energy is stored in the deformed soil. As the soil “springs back”, an upward force is exerted upon the leg, helping to propel it forward. This is much like what happens when a runner’s foot impacts the ground.

The following calculation was done to further explore this concept:

We can model the legs as a wheel with rigid spokes. By looking at the equation of motion for the system, as well as the collision dynamics, it is possible to come up with a system of equations which can then be used to simulate the interaction between the legs and a soft terrain.

### *Equation of Motion*

We can use the Lagrange method to find the equation of motion for the system shown in figure 11 below:

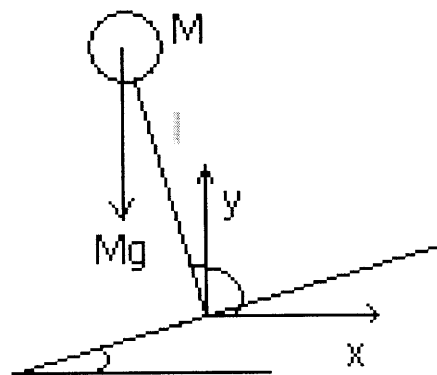

**Figure 11: Leg Modeled as Mass-Rod Pendulum**

Where  $M$  is the mass of the wheel,  $g$  is the acceleration due to gravity (approximately  $9.8\text{m/s}^2$ ),  $\alpha$  is angle between the surface and the horizontal plain,  $\theta$  is the angle of the rod with respect to the

horizontal plane, and  $l$  is the length of the spoke. Note  $x$  and  $y$  represent the  $x$  and  $y$  components of  $l$ . Also note that for simplification, we are treating it as a fixed mass and a single rod, acting as a pendulum on some incline  $\alpha$ .

The Lagrange solution is found using the following equations:

$$L = KE - PE \quad (1)$$

$$\tau = \frac{d}{dt} \frac{\partial L}{\partial \dot{\theta}} - \frac{\partial L}{\partial \theta} \quad (2)$$

Where  $\tau$  represents the torque placed upon the wheel. Equations 3 and 4 below give the kinetic energy,  $KE$ , and the potential energy,  $PE$ , in terms of  $M$ ,  $l$ , and  $\theta$ :

$$KE = \frac{1}{2} M l^2 \dot{\theta}^2 \quad (3)$$

$$PE = M l \sin \theta \quad (4)$$

Note that  $\dot{\theta}^2$  is equal to the angular velocity of the wheel as it rolls down the incline.

Inserting equations 3 and 4 into equation 1 gives us equation 5:

$$L = \frac{1}{2} M l^2 \dot{\theta}^2 - M l \sin \theta \quad (5)$$

Solving for  $\tau$ :

$$\tau = M l^2 \ddot{\theta} - M l \cos \theta \quad (6)$$

The torque applied to the wheel is a function of both the angular position,  $\theta$  and the angular acceleration,  $\ddot{\theta}$ . If we rewrite equation 6 in matrix form, it is possible to solve for both the angular position and angular acceleration, allowing us to model the motion of the system as a whole.

$$\begin{bmatrix} \ddot{\theta} \\ \dot{\theta} \end{bmatrix} = \begin{bmatrix} 0 & 0 \\ 1 & 0 \end{bmatrix} \begin{bmatrix} \dot{\theta} \\ \theta \end{bmatrix} + \begin{bmatrix} \frac{r + m l \cos \theta}{m l^2} \\ 0 \end{bmatrix} \quad (7)$$

### Collision Dynamics

Figure 12 below shows the free body diagram about the point  $P$ :

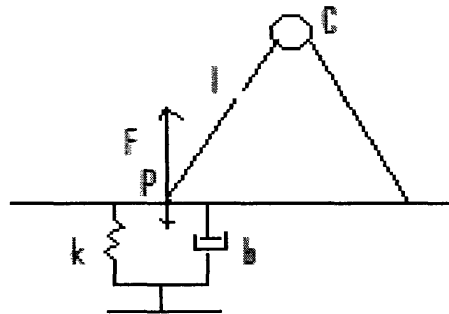

**Figure 12: Collision between leg and soft ground**

$P$  is the point of contact,  $F$  is the vertical force due to collision, and  $l$  is the length of the leg. There is also an angular velocity of point  $C$  as given by  $\dot{\theta}$ . Note that the ground is being modeled as a fixed mass-spring-damper system with a spring constant,  $k$ , and a damping coefficient,  $b$ . By modeling the ground in this way, we are able to investigate the effects of the deformation and reformation which occur when the leg collides with the softer ground.

Basic collision dynamics states that the post-collision velocity,  $\vartheta_p^{post}$ , is equal to the pre-collision velocity,  $\vartheta_p^{pre}$ , multiplied by the negative coefficient of elastic collision,  $e$ , as shown in equation 8 below:

$$\vartheta_p^{post} = -e\vartheta_p^{pre} \quad (8)$$

We know that the value of  $e$  is dependent upon the values of both  $k$  and  $b$ . The relationship between the three can be determined experimentally, however for our purpose we will simply model the relationship as in equation 9 below.

$$e = \frac{(kb)/\alpha}{(kb)/\alpha + 1} \quad (9)$$

Equation 9 above is a suitable model, for as  $kb$  goes to zero, so does the coefficient of elastic collision (which would mean a perfectly inelastic collision), whereas if  $kb$  goes to infinity, so does  $e$  (which would be a perfectly elastic equation).

Three more important equations are given below:

$$\dot{\theta}^{post} = \dot{\theta}^{pre} - \frac{\|F\| \cdot j \times r_{cp}}{I} \quad (10)$$

$$\vartheta_C^{post} = \vartheta_C^{pre} - \frac{\|F\| \cdot j}{M} \quad (11)$$

$$\vartheta_p^{post} = \vartheta_C^{post} + \dot{\theta}^{post} \times r_{cp} \quad (12)$$

Equations 10, 11, and 12 above give us the post-collision conditions. Solving for the post collision velocity give equation 13:

$$\vartheta_p^{post} = \left( \vartheta_p^{pres} - \frac{\|F\| \cdot j}{M} \right) + \left( \left( \dot{\vartheta}^{pres} - \frac{\|F\| \cdot j \times r_{cp}}{I} \right) \times r_{cp} \right) \quad (13)$$

Rearranging, and realizing that

$$\vartheta_c^{pres} + \dot{\vartheta}^{pres} \times r_{cp} = \vartheta_p^{pres} \quad (14)$$

Gives equation 15:

$$-e\vartheta_p^{pres} = \vartheta_p^{pres} - \|F\| \left( \frac{1}{M} + \frac{r_{cp}^2}{I} \right) \quad (15)$$

Solving for the collision force gives us

$$F = \frac{(1+e)\vartheta_p^{pres}}{\left( \frac{1}{M} + \frac{r_{cp}^2}{I} \right)} \quad (16)$$

Returning to the mass-spring-damper system, we get the following equation of motion

$$M\ddot{\Delta} + b\dot{\Delta} + k\Delta = F\delta(t_i) \quad (17)$$

Note that there is a forcing function which represents the time in which the leg is in contact with the ground. It is assumed that there is a force at  $t_i$  only (not before), hence the delta function,  $\delta(t_i)$ . Also important to note is that the equation has the variable  $\Delta$ . This represents the amount of deformation in the ground upon collision with the leg.



Rewriting equation 17 in matrix form, we get

$$\begin{bmatrix} \ddot{\Delta} \\ \dot{\Delta} \end{bmatrix} = \begin{bmatrix} 0 & 0 \\ 1 & 0 \end{bmatrix} \begin{bmatrix} \dot{\Delta} \\ \Delta \end{bmatrix} + \begin{bmatrix} \frac{F\delta(t_i) - b\dot{\Delta} - k\Delta}{M} \\ 0 \end{bmatrix} \quad (18)$$

Lastly, if we combine the matrix equations for both the *equation of motion* and the *collision forces* components, we can get a system of ordinary differential equations which can be used to model the behavior of a leg upon collision with soft ground.

$$\begin{bmatrix} \ddot{\theta} \\ \dot{\theta} \\ \ddot{\Delta} \\ \dot{\Delta} \end{bmatrix} = \begin{bmatrix} 0 & 0 & 0 & 0 \\ 1 & 0 & 0 & 0 \\ 0 & 0 & 0 & 0 \\ 0 & 0 & 1 & 0 \end{bmatrix} \begin{bmatrix} \dot{\theta} \\ \theta \\ \dot{\Delta} \\ \Delta \end{bmatrix} + \begin{bmatrix} \frac{ml\cos\theta}{ml^2} \\ 0 \\ \frac{F\delta(t_i) - b\dot{\Delta} - k\Delta}{M} \\ 0 \end{bmatrix} \quad (19)$$

### 3.2.3 Further Applications

Using some numerical program such as MATLAB, it is possible to use equation 19 to simulate the motion of a leg upon collision with the ground. We would expect the results of such a simulation to show an additional force when the leg leaves contact with the ground (after the initial collision, the leg remains in contact with the ground for a small amount of time, then lifts up again). This force is caused by the restoration of the soil back to its original position (after the deformation caused by the initial collision). We would expect this force to add to the forward motion of the leg, and in turn the robot. However, just as the sensing design is in the preliminary stages, so is this simulation. Further testing will be needed in order to determine the extent of energy gained due to the spring back of the ground.

---

## Bibliography

Adopt-a-Minefield. *Landmine: A History*. <http://www.landmines.org/crsis/history.cfm> (accessed 5 2008).

Bonsor, Kevin. *How Landmines Work*. June 19, 2001. <http://science.howstuffworks.com/landmine.htm> (accessed 4 20, 2008).

Human Rights Watch. *Landmine Monitor Report*. United States: International Campaign to Ban Landmines, 2006.

International Committee of the Red Cross. *Anti-personnel Landmines Friend or Foe?* Geneva: International Committee of Red Cross, 1996.

Landmine Monitor Group. *Landmine Monitor Report*. United States: International Campaign to Ban Landmines, 2006.

—. *Landmine Monitor Report*. United States: International Campaign to Ban Landmines, 2007.

Landmine Survivors Network. *Landmine Survivors Network*. [www.landmine-survivors.org](http://www.landmine-survivors.org) (accessed 4 20, 2008).

MacDonald, Jaqueline, et al. *Alternatives for Landmine Removal*. Santa Monica: RAND, 2003.

RONCO Consulting Corporation. *Mine/UXO Clearance FAQ Demining with Dogs*. 2008. <http://www.demining.com/hmc/faq.html> (accessed 5 1, 2008).

Strada, Gino. "The Horror of Landmines." *Scientific American*, 1996.

US Department of Defense Humanitarian Demining. "Developmental Technologies." 1998.

US Department of Defense Humanitarian R&D Program. *Minefield Challenges*. [www.humanitarian-demining.org/NewDesign/Threats\\_minefield.asp](http://www.humanitarian-demining.org/NewDesign/Threats_minefield.asp) (accessed 4 27, 2008).